



WATCHES

AND HOROLOGICAL REVIEW.

D. H. HOPKINSON: EDITOR & PROPRIETOR.

11. 10. 60

Volume XIV, 1883.

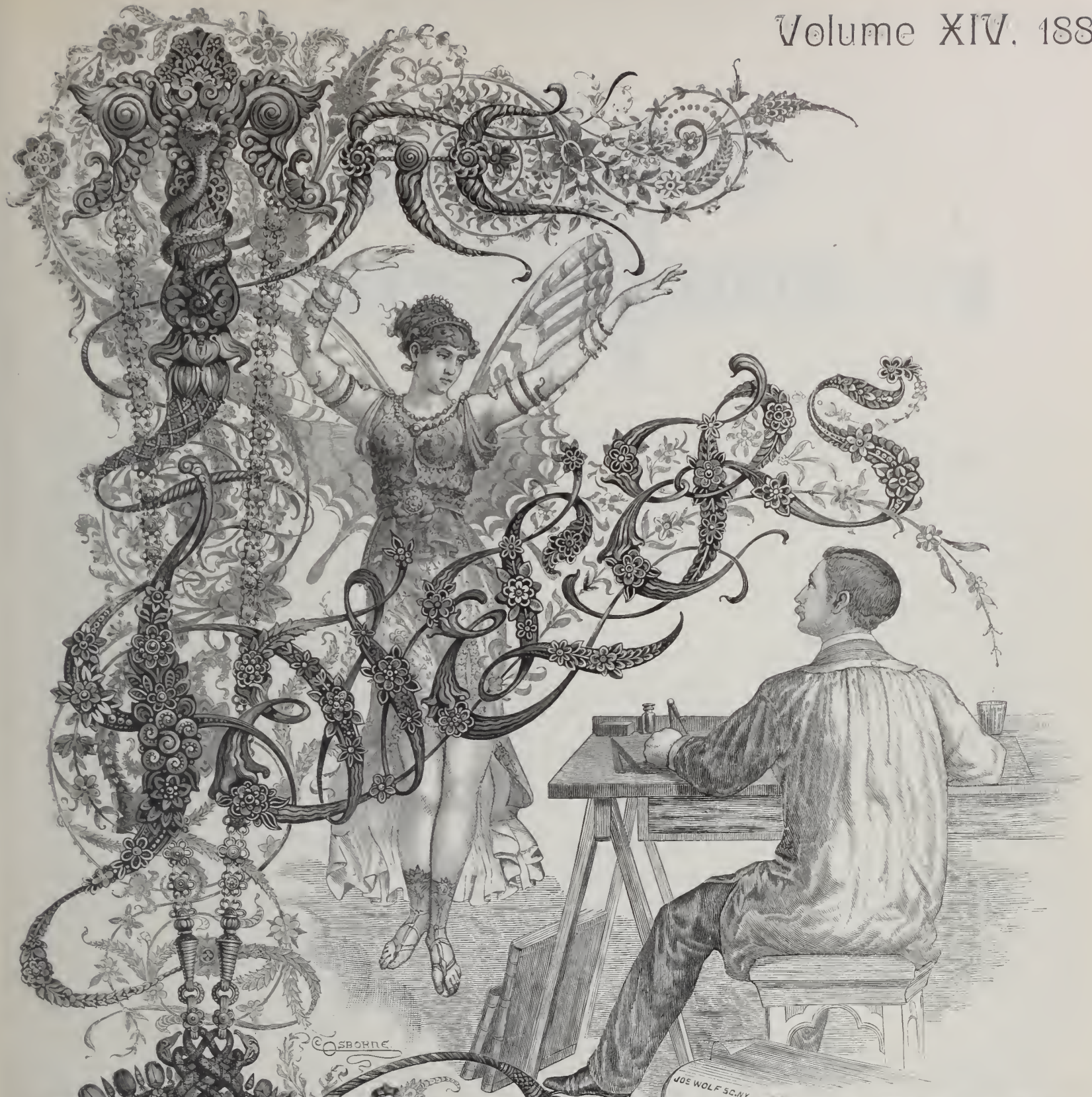

OSBORNE

JOE WOLF SC.NY

THE JEWELRY AND HOROLOGICAL REVIEW.

D. H. FOPKINSON: EDITOR & PROPRIETOR.

INDEX TO
VOLUME XIV.

<i>FEBRUARY.</i>	PAGE.
Analysis of Metals.....	16
Annual Banquet of the Chicago Jewelers' Association.....	22
Art, Galvano-Plastic.....	21
Associations, State.....	2
Astronomer's Observation.....	14
Australian Representative, Honors to.....	15
Bric-à-Brac.....	17
Celebrating the Production of the 2,000,000th Watch.....	22
Cheap Aluminum.....	18
Chicago Jewelers' Association, Annual Banquet of.....	22
Crystals, Watch.....	17
Custom House Tariff on Precious Stones.....	3
Diamonds, A Remarkable Pair of.....	20
Discoveries, Important.....	19
Fire and Burglar-Proof Building.....	12
Fourteenth Volume, Our.....	1
Galvano-Plastic Art.....	21
Gold and Silver, Their Elaboration.....	25
Gold, Silver and Nickel-Plating, etc.....	4
Harrison, John, the Chronometer Maker.....	7
Honors to an Australian Representative.....	15
Horological Club, Proceedings of the.....	23
Important Discoveries.....	19
Jewelers' League, Sixth Annual Meeting.....	12
Metals, Analysis of.....	16
Music Boxes.....	18
Nuptial Present.....	6
Obituary:—	
John T. Mauran.....	16
John M. Bonnet.....	16
John Carrow.....	16
Observation, Astronomer's.....	14
Our Fourteenth Volume.....	1
Our New Title Page.....	2
Plating, Gold, Silver and Nickel, etc.....	4
Precious Stones, The Custom House Tariff on.....	3
Proceedings of the Horological Club.....	23
Production of the 2,000,000th Watch, Celebrating the.....	22
Rare Gems.....	10
Remarkable Pair of Diamonds.....	20
Retail Jewelers of Wisconsin, To the.....	20
Sight.....	28
Sixth Annual Meeting of the Jewelers' League.....	12
Social Intercourse.....	4
State Associations.....	2
Stroll through a Watch Factory, etc.....	27
Thermometer, The.....	9
Title Page, Our New.....	2

	PAGE.
Trade Gossip.....	31
Volume, Our Fourteenth.....	1
Watch Crystals.....	17
Watch Factory, etc., Stroll through a.....	27
Watch Repairing.....	15
Workshop Notes.....	30

MARCH.

	PAGE.
Advice to Watchmakers' Apprentices.....	59
Barometer, The.....	42
Bending Breguet Spring.....	53
Clockmakers' Lock-up.....	54
Complaint.....	36
Construction of a French Clock Anchor.....	52
Construction of a Pin Escapement.....	37
Correct Local Time and How to Obtain It.....	41
Cylinder Escapement.....	39
Diamond, History of the.....	38
Diamond Trade.....	36
Fac Similes of Antiques.....	53
Failures, Unnecessary.....	33
Gilding, Simple Method for.....	45
Glass Etching.....	54
Gold and Silver, Their Elaboration.....	47
History of the Diamond.....	38
Horological Club, Proceedings of the.....	56
Important Discoveries.....	40
Jewelers' League.....	36
Jewelry from the Tombs of Chiriqui.....	58
Labor Agitators.....	35
Lathes and Lathe Work.....	44
League, The Jewelers'.....	36
Making Small Drills.....	53
Marvels of Mechanism.....	60
Mistake, a State Association's.....	34
Mysterious Robbery.....	38
Pin Escapement, Construction of a.....	37
Pretended Diamond Frauds.....	36
Proceedings of the Horological Club.....	56
Sight.....	59
Simple Method for Gilding.....	45
State Association's Mistake.....	34
Tariff, Tinkering at the.....	34
Tinkering at the Tariff.....	34
Tombs of Chiriqui, Jewelry from the.....	58
Trade Gossip.....	63
Unbusiness-like Competition.....	35
Unnecessary Failures.....	33
Watchmakers' Apprentices, Advice to.....	59
Watch Repairing.....	55
Workshop Notes.....	62

	PAGE.
Æsthetic Shams.....	86
Age of Shams.....	70
Celebrated Horologists.....	87
Coins, United States.....	68
Correct Local Time, etc.....	92
Crowning of the Czar.....	90
Cylinder Escapement.....	76
Dealers, Retail.....	65
Diamond Mines, South African, A Trip to the.....	78
Electro-Gold and Silver Plate.....	81
Fifth Annual Meeting of Jewelers' Protective Union.....	67
Fitch, E. C., appointed Treasurer.....	70
Foreign Gossip.....	93
German Imperial Insignia.....	68
Gold and Silver, their Elaboration.....	72
Horological Club, Proceedings of.....	71
Horological School at Glashütte.....	90
Importance of Jewelers' Exchange.....	68
Important Discoveries.....	75
Insignia, German Imperial.....	68
Jewelers' Exchange, Importance of.....	68
Jewelers' League.....	85
Jewelers' Protective Union, Fifth Annual Meeting of.....	67
Lathes and Lathe Work.....	91
Manufacture of Toy Watches.....	69
Newport's Old Clocks.....	70
Obituary:—Richardson, Hon. T. A.....	70
Old Clocks, Newport's.....	70
Proceedings of Horological Club.....	70
Protection for Retail Dealers.....	66
Removals.....	87
Retail Dealers.....	65
Retail Dealers, Protection for.....	66
Sight.....	88
Spirits of Lavender for Strengthening the Eyes.....	90
Tinkering the Tariff.....	67
Toy Watches, Manufacture of.....	69
Trade Gossip.....	95
Trip to the South African Diamond Mines.....	78
United States Coins.....	68
Watch Repairing.....	83
Workshop Notes.....	94

MAY.

	PAGE.
Advice to Watchmakers' Apprentices.....	106
Aluminum.....	114
Cautioning Retail Dealers.....	112
Complaints of Retail Dealers.....	99

	PAGE.
Complaints of Silverware.....	101
Confessions of a Bric-à-Brac Dealer	121
Detached Lever Escapement, Problems in the..	102
Diamond Country in Africa.....	114
Diamond Mines, South African, A Trip to....	107
Electric Rat Traps.....	100
Electro-Gold and Silver Plate.....	103
Fright of Manufacturers.....	99
Galvano-Plastic Art.....	116
Gold and Silver, Their Elaboration.....	123
Gold from Gold-Plated Articles.....	105
Horological Club, Proceedings of the.....	117
How to Separate Gold from Gold-Plated Arti- cles.....	105
Increase of Confidence.....	100
Jewelers' League.....	101
Jewelers' Security Alliance.....	113
Lyre Clock.....	120
Manufacturers, Fright of.....	99
May Removals.....	113
Obituary:—J. T. Scott.....	114
Politeness is Cheap.....	98
Problems in Detached Lever Escapement.....	102
Proceedings of the Horological Club.....	117
Retail Dealers and Outsiders.....	97
Retail Dealers, Complaints of.....	99
Security Alliance, The Jewelers'.....	113
Sight.....	119
Smuggling	118
Solubility of Glass.....	125
Stroll Through a Watch Factory.....	108
Trade Gossip.....	127
Triplex Escapement.....	115
Trip to the South African Diamond Mines...	107
Vaucanson.....	125
Views of Correspondents.....	111
Watches and Personal Magnetism	125
Workshop Notes.....	126

JUNE.

	PAGE.
Advice to Watchmakers' Apprentices.....	143
Catalogue Business.....	132
Construction of a Watch.....	153
Correct Local Time.....	142
Cylinder Escapement.....	135
Electro-Gold and Silver Plate.....	133
Fine Varnish.....	142
Frontier Jobbers.....	130
Galvano-Plastic Art.....	153
Gold Alloy.....	150
Gold and Silver, Their Elaboration.....	139
Gold, Value of.....	144
Great Stoneville Boom.....	137
Guild, Traveler Finds the.....	155
Horological Club, Proceedings of.....	145
Industrial Organizations of France.....	151
Jewelers' League.....	151
Lathes and Lathe Work.....	146
New Haven Painted Diamond Case.....	131
Old Wares.....	137
Painted Diamond Case, The New Haven.....	131
Proceedings of Horological Club.....	145
Repairing Watches.....	150
Retail Dealers and Outsiders.....	129
Scientific Notes	156
Sight.....	148
Stoneville Boom, The Great.....	137
Trade Gossip.....	159
Traveler Finds the Guild.....	156
Value of Gold.....	144
Views of Correspondents.....	147
Watchmakers' Apprentices, Advice to.....	143
What Retailers and Jobbers are Doing.....	158
Workshop Notes.....	157

JULY.

	PAGE.
Advice to Watchmakers' Apprentices.....	169
Anchor Pivots, Easing of the.....	179
Art of Goldsmithing in Antiquity.....	171
Balance Staff, Replacing a Broken... ..	188
Correct Local Time and How to Obtain It....	172
Cylinder Escapement.....	182
Double Callipers, Improved.....	184
Easing of the Anchor Pivots.....	179
Galvano-Plastic Art.....	168
Gold and Silver, Their Elaboration.....	177
Hair Springing.....	189
High-class Jewelry.....	173
Horological Club, Proceedings of.....	166
Improved Double Callipers.....	184
Jewelers' Alliance.....	164
Jewelers' League	165
Jobbers, Some Grievances of the.....	161
Kimberley Diamond Mine.....	163
Lathes and Lathe Work.....	176
Novel Method of Stealing Diamonds.....	165
Pinions, Turning in.....	185
Proceedings of the Horological Club.....	166
Replacing a Broken Balance Staff.....	188
Robbing of Retail Jewelers.....	163
Setting of Watch Jewels.....	187
Sight.....	184
Smuggling by Mail.....	164
Smuggling to Canada.....	163
Some Grievances of the Jobbers.....	161
Standard Time.....	164
State Associations.....	162
Table Utensils.....	179
Trade Gossip.....	191
Turning in Pinions.....	185
Views of Correspondents.....	174
Watch Jewels, The Setting of.....	187
Watch Repairing.....	184
Wolfgang von Kempelen.....	170
Workshop Notes.....	190

AUGUST.

	PAGE.
Annual Product of Watches.....	221
Annual Report of Yale Observatory.....	195
Aristarchus Plumbago—the Flop-over Brigade,	199
Artificial Jewels, Manufacture of.....	213
Art of Goldsmithing in Spain.....	205
Advice to Watchmakers' Apprentices.....	212
Cape Mines, Distress of.....	195
Clocks and Watches, Curiosities of.....	214
Coloring Common Gold Articles... ..	218
Curiosities of Clocks and Watches.....	214
Cylinder Escapement.....	219
Detached Lever Escapement, Problems in the,	207
Distress of Cape Mines.....	195
Flop-over Brigade, and Aristarchus Plumbago,	199
Four-cylinder Watch, Adjustment of.....	201
Gold Articles, Coloring Common.....	218
Hair Springing.....	217
Horological Club, Proceedings of.....	197
How to Grind and Polish Pallet Jewels.....	211
Jewelers' Day.....	195
Jewelers League.....	209
Lathes and Lathe work.....	208
Letting down Anchor Wheels.....	216
Manufacture of Artificial Jewels.....	213
Organization of a Joint Stock Company.....	194
Pallet Jewels, How to Grind and Polish.....	211
Perpetual Motion.....	211
Practical Treatise on the Adjustment of a Four- Cylinder Watch.....	201
Problems in the Detached Lever Escapement..	207
Proceedings of the Horological Club.....	197
Retail Dealers and Outsiders.....	193
Royal Silverware of France.....	208
Sight.....	210

	PAGE.
State Societies.....	219
Table Utensils.....	203
Theoretical Instruction in Horology.....	216
Trade Gossip.....	223
Transmission of Power.....	215
Views of Correspondents.....	216
Watchmakers' Apprentices, Advice to.....	212
Wooden Watches.....	215
Workshop Notes.....	222
Yale Observatory, Annual Report of.....	195

SEPTEMBER.

	PAGE.
Advice to Watchmakers' Apprentices.....	232
Ascertaining Exact Error of Regulator.....	235
Aurora Watch Company	241
Balance Springs, Effect of Heat on.....	251
Business Outlook.....	225
China Painting.....	256
Contributions to the History of Watchmaking..	235
Demand for Thermometers.....	254
Depthings	227
Detached Lever Escapement, Problems in the..	251
Effect of Heat on Balance Springs.....	251
Famous Diamond	254
Filigree Jewelry.....	233
History of Watchmaking, Contributions to....	235
How to Make and Engrave Silver Bangles... ..	237
Jewelers' League.....	244
Jewelers' Security Alliance... ..	230
Lathes and Lathe Work.....	238
More Art in Wrought Gold Required.....	226
National Exposition at Zurich.....	244
Obituary:—Herman Nordlinger, Charles W. Buechner, J. F. Hopkinson.....	255
Practical Treatise on the Adjustment of a Four-Jeweled Cylinder Watch	246
Problems in the Detached Lever Escapement..	251
Proceedings of the Horological Club.....	250
Remarks on the Construction of a Second Regu- lator.....	228
Repairing Watch Cases.....	239
Rings.....	253
Security Alliance, The Jewelers'.....	230
Sight.....	248
Silver Bangles, How to Make and Engrave ..	237
Table Utensils.....	242
Tool for Turning Oval.....	236
Trade Gossip.....	258
Watch Cases, Repairing.....	239
Watchmakers' Apprentices, Advice to.....	232
Workshop Notes.....	257

OCTOBER.

	PAGE.
Abuses of the Memorandum System.....	262
Advice to Watchmakers' Apprentices.....	259
Bankruptcy Law, Necessity for a.....	261
British House of Commons.....	265
Certain Classes of Western Jobbers.....	264
Cup—Its Art and Customs.....	272
Demoralization.....	264
Depthings.....	274
Detached Lever Escapement, Problems in the	290
Development of Watchmaking in Spain.....	279
Filigree Jewelry.....	282
Foreign Gossip.....	295
Four-Jeweled Cylinder Watch, Practical Trea- tise on.....	294
German Watches and Clockmakers.....	292
Horological Club, Proceedings of the.....	286
How to Make and Engrave Silver Bangles... ..	293
Jewelers' League.....	265
Jewelers' Security Alliance.....	286
Lathes and Lathe Work.....	289

	PAGE.
Method of Treating Gold and Silver Sweep in the Assay Office.....	277
Musical Box—And How to Repair It.....	268
Necessity for Bankruptcy Law.....	261
Nickel Plating.....	280
Ornamenting Glass, China, &c.....	292
Peripatetic Swindlers.....	262
Practical Treatise on the Adjustment of a Four-Jeweled Cylinder Watch.....	294
Pretentious Papers.....	264
Problems in the Detached Lever Escapement..	290
Proceedings of the Horological Club.....	286
Question of Adoption.....	265
Repairing Watch Cases.....	278
Security Alliance, The Jewelers'.....	286
Silver Bangles, How to Make and Engrave....	293
Table Utensils.....	266
Trade Gossip.....	298
Valuable Articles.....	265
Views of Correspondents.....	281
Watch Cases, Repairing.....	278
Watchmakers' Apprentices, Advice to.....	289
Western Jobbers, Certain Classes of.....	264
Workshop Notes.....	296

NOVEMBER.

	PAGE.
Adoption of Common Time.....	304
Advice to Watchmakers' Apprentices.....	322
Cameos.....	330
Clock Trains.....	316
Colored Films on Metals.....	332
Common Justice.....	304
Condition of the Retail Dealers.....	301
Crocus for Polishing Steel.....	332
Cup—Its Art and Customs.....	306
Depthings.....	327
Depthing-Tool for the Angular Depthing of Stemwinders.....	314
Detached Lever Escapement, Problems in the	326
Diamond Trade.....	303
Disreputable Practices.....	302
Electricity Not a Form of Magnetism.....	329
Fashions in Jewelry.....	329
Foreign Gossip.....	336
Four-Jeweled Cylinder Watch, Adjustment of a.....	311
Gilding Watch Parts, &c.....	333
Goods for the Holiday Trade.....	304
How Diamonds are Smuggled Over the Canada Border.....	310
Horological Club, Proceedings of the.....	323
How to Make and Engrave Silver Bangles....	317
Invention of the Thermometer.....	332
Japanese Division of Time and Clocks.....	334
Jewelers' League.....	305
Lathes and Lathe Work.....	335
Memorandum System.....	304

	PAGE.
Modern Art Taste, Review of.....	313
National Exposition at Zurich.....	318
Obituary:—Louis A. Cuppia, Alexander M. Hays.....	333
Perpetual Calendar.....	315
Practical Treatise on the Adjustment of a Four-Jeweled Cylinder Watch.....	311
Problems in the Detached Lever Escapement	326
Proceedings of the Horological Club.....	323
Recoil Pin Escapement.....	321
Repairing a Timepiece.....	309
Repairing Watch Cases.....	320
Retail Dealers, Condition of the.....	301
Review of Modern Art Taste.....	313
Rush of Business.....	305
Setting of Scape Wheels.....	331
Sight.....	325
Soldering and Melting.....	330
Soldering without an Iron.....	330
Some Things of Old Spain.....	331
Trade Gossip.....	338
Views of Correspondents.....	325
Watch Cases, Repairing.....	320
Watchmakers' Apprentices, Advice to.....	322
Watch Trials at Neuchatel.....	328
Workshop Notes.....	337

DECEMBER.

	PAGE.
Advice to Watchmakers' Apprentices.....	376
American Gems and Precious Stones.....	356
Artistic Oddities.....	358
Banquet, The Jewelers' Association.....	343
Bench, Echoes from the.....	359
Cup, The—Its Art and Customs.....	345
Cylinder Watch, Practical Treatise of a.....	361
Detached Lever Escapement, Problems in the,	375
Diversified Stocks.....	341
Echoes From the Bench.....	359
Emerald found.....	374
Foreign Gossip.....	377
Gilding Watch Parts.....	353
Horological Club, Proceedings of the.....	370
How to Make and Engrave Silver Bangles....	372
Imitation Stained Glass.....	373
Jewelers' Association Banquet.....	343
Jewelers' Association, The New York.....	363
Jewelers' League, The.....	344
Jewelers' Safes.....	343
Manufacture of Mainsprings.....	350
Memorandum Victims.....	342
National Exposition at Zurich.....	354
New York Jewelers' Association.....	363
On the Road.....	369
Palmer House, Chicago.....	344
Pendulum Fork, A.....	358
Practical Treatise of a Cylinder Watch.....	361
Problems in the Detached Lever Escapement..	375

	PAGE.
Proceedings of the Horological Club.....	370
Railroad Time, Standard.....	373
Repairing Watch Cases.....	353
Retail Dealers.....	344
Road, On the.....	369
Sharp Practice.....	343
Silver Bangles, How to Make and Engrave....	372
Small Trade Worth Looking After.....	342
Spherical Clock, The.....	349
Stained Glass, Imitation.....	373
Standard Railroad Time.....	373
Trade Gossip.....	379
Two Green China Jars.....	349
Watch Cases, Repairing.....	353
Watch Manufacture in England.....	355
Watch Parts, Gilding.....	355
Workshop Notes.....	378

JANUARY.

	PAGE.
Adjustment of a Cylinder Watch.....	408
Advice to Watchmakers' Apprentices.....	399
American Gems and Precious Stones.....	386
Bench, Echoes from the.....	403
Bronzing Iron.....	397
Clock Trains.....	390
Cup—Its Art and Customs.....	394
Depthings.....	392
Detached Lever Escapement, Problems in the.	400
Echoes from the Bench.....	403
End of Volume XIV.....	381
French Government Swindled.....	407
French Jewelry.....	407
Horological Club, Proceedings of the.....	401
How to Make and Engrave Silver Bangles ...	393
Iron Bronzing.....	397
Jewelers' League.....	397
Jewelers' Security Alliance.....	409
Lacquer Ware.....	384
Lathes and Lathe Work.....	388
League, Jewelers'.....	397
New Time Standard.....	393
New York, The Supremacy of.....	382
Obituary—Charles Wood.....	409
Precious Stones, American Gems and.....	386
Problems in the Detached Lever Escapement..	400
Proceedings of the Horological Club.....	401
Sight.....	389
Signs of the Times.....	384
Silver Bangles, How to Make and Engrave....	393
Sir William Siemens.....	396
Supremacy of New York, The.....	382
Times, Signs of the.....	384
Trade Gossip.....	411
Ugly Rumors.....	384
Views of Correspondents.....	409
Volume XIV, End of.....	381
Watchmakers' Apprentices, Advice to.....	399
Workshop Notes.....	410



ART TYPE

E BIERSTADT, N. Y.

GROUP OF
STERLING SILVER WARE BY THE
GORHAM M'F'G CO.

GORHAM MF'G COMPANY,
Silversmiths.

37 UNION SQUARE, NEW YORK.

170 State Street,
CHICAGO, ILLS.

120 Sutter Street,
SAN FRANCISCO, CAL.

FACTORY:
PROVIDENCE, R. I.

ON THE preceding page we present an ALBERTYPE GROUP, showing examples of our Later Productions in Hollow Ware, designed to illustrate the Different Varieties of Decoration, rather than to show our Most Expensive Wares exclusively.

Our Stock always contains an Assortment of this Class of Goods, and Customers who cannot carry such goods in their stock continuously are often enabled to effect Large Sales by availing themselves of the privilege we extend them, of sending this class of Wares for their approval or selection.

Gorham Mfg Company,

SILVERSMITHS.



VOLUME XIV.

NEW YORK, FEBRUARY, 1883.

No. 1.

THE JEWELERS' CIRCULAR AND HOROLOGICAL REVIEW

*The recognized organ of the Trade, and the official representative of the
Jewelers' League.*

A Monthly Journal devoted to the interests of Watchmakers, Jewelers, Silver-
smiths, Electro-plate Manufacturers, and those engaged in the
kindred branches of art industry.

SUBSCRIPTION:

To All Parts of the United States and Canada,
\$2.00 Per Annum; Postage paid.

To Great Britain, France, Switzerland, Germany, the West Indies, Mexico, the
Republics of South America, and Australia, \$3.00 per annum. Postage paid.

*All communications should be addressed to D. H. HOPKINSON, 42 Nassau
Street, New York. Advertising rates made known on application.*

NOTICE TO SUBSCRIBERS.

The Fourteenth Volume of THE JEWELERS' CIRCULAR begins with the present number. Those of our readers whose term of subscription has expired, and who have been notified by our usual circular, will confer a favor by responding as promptly as possible, as all subscriptions terminating with the last volume will be discontinued if not renewed.

Our Fourteenth Volume.

WITH THIS issue of THE CIRCULAR we enter upon our fourteenth volume and the fourteenth year of the consecutive publication of this journal. In taking a retrospective glance at the career of THE CIRCULAR we cannot but feel a pride in the record it has made and the confidence that has been shown it as the representative organ of the jewelry trade. Our chief source of pride lies in the educational features that have been presented in our columns. It has been our ambition to present to the trade technical articles, prepared by practical and scientific men, that should in themselves constitute text books for that grand army of workmen, in the shop and in the counting room, who are earnestly seeking to elevate the arts in gold and silver work and the science of horology. To this end we have paid liberal sums to our own corps of special writers as well as to translators, who have given us in English the best ideas of noted French and German workers. Great pains have been taken with these articles, and in each instance they have been carefully revised by those who prepared them, so that when printed in our columns they have truthfully reflected the ideas of their authors. By this means we can claim that the influence of THE CIRCULAR has been felt in every workshop in the land, and has left its mark upon the

workmanship of the age. We have felt from the first that this was the most important part of our mission, and have, consequently, grudged neither trouble nor expense in ministering to it. And now, as we enter upon our fourteenth volume, we feel that we may ventilate a little pardonable pride by this brief allusion to the educational characteristics of THE CIRCULAR.

During its career, THE CIRCULAR has ever been the friend of the retail dealers. Recognizing that they constitute the medium by means of which the manufacturers and jobbers must reach their patrons, the general public, we have at all times sought to protect them in the rights that inhere to their position, and to discountenance those illegitimate methods adopted by a few unscrupulous jobbers and manufacturers to rob them of their trade. We have believed that the success of the trade in general is dependent upon the maintenance of the integrity of the retail portion of it, as the great distributing outlet through which all its products should flow, and so believing, we have honestly and earnestly sought to protect it in all its prerogatives. In doing so we have at times been compelled to make war upon some of our best friends, because they endeavored to build up for themselves a retail trade while ignoring the retail dealers. Whatever we have regarded as unfair or illegitimate we have not scrupled to denounce, regardless of consequences. Our aggressiveness has often aroused the hostility of those whose plans we exposed and whose prospects we defeated thereby, but the consciousness that we were right and that time would prove it so, has been our consolation. The fact that THE CIRCULAR enjoys to-day the confidence of the trade in a marked degree is testified to by our large subscription list and generous patronage. Few trade papers in this country can truthfully claim a circulation equal to ours, or an influence so far reaching. While we are truly grateful for the confidence and patronage bestowed upon us, we cannot but feel that we have fairly deserved the former and that for the latter we have honestly given the *quid pro quo*.

We do not care to make promises for the future, but will simply point to our record in the past as an earnest of what may be expected of us in the years to come. The corps of writers who have so enriched our columns with technical literature will continue their contributions from month to month, while new features will be added from time to time as circumstances warrant. We are at all times ready to pay liberally for special articles, and invite contributions on technical topics from whoever has anything to say. In our editorial and news columns we shall present and discuss the current news in the trade, and all matters of interest that arise from time to time, thus keeping our readers informed of what is transpiring at the principal trade centers. We shall give in each issue, also, brief notices of what the manufacturers are doing, thus keeping the retail dealers informed regarding new designs and novelties that are being constantly introduced and of the progress that is being made in the arts. In short, we shall endeavor to make THE CIRCULAR a truthful reflex of the best thoughts that prevail and of the current news in the trade. We hope to make a paper that will commend itself to every intelligent man, be he

employer or workman, and we shall be glad to have the support and encouragement of all such as feel that THE CIRCULAR is a benefit to them. On its merits, and upon no other consideration, do we base our claims to the patronage of the trade. Having thus launched the initial number of the new volume, we wish the trade all prosperity for the coming year, a large volume of business and a good margin of profit thereon.

Our New Title Page.

OUR READERS will not fail to have their attention arrested by the beautiful new cover page that decorates this issue of THE CIRCULAR. The exquisite taste and delicate tracery in the design have seldom been excelled in this line of art, and bear ample testimony to the artistic skill of Mr. Charles Osborne, designer for the Whiting Manufacturing Company. Mr. Osborne has given to the trade, in the designs of the Whiting Company, abundant illustration of the fact that he is one of the first artists in the country, possessed of an artistic skill and poetic fancy in rare combination. We invite the closest study of our cover page, and the more it is studied the greater will be the admiration for the many exquisite fancies embodied in it. The working out of Mr. Osborne's idea has been creditably done by Joseph Wolf, one of the most successful engravers in New York. These are the same artists who made the cover design that has adorned THE CIRCULAR for the past seven years, and which has been so generally admired not only by members of the trade, but by artists, designers and printers. We are exceedingly loth to part with our old cover, but the "tooth of time" has been at work upon the plates, and as a renewal of them became necessary, it was thought a new design would be desirable. The old cover had become to THE CIRCULAR like a trade mark, making our journal readily recognizable at a glance wherever it might be encountered. The design of it was something unique, and the marginal combination of exquisite forms was full of suggestion, and has formed the basis of many new designs in works of personal ornamentation. In short, it has been a plate full of suggestions, instructive alike to the beginners in artistic work and to the mature designer. For many reasons we regret divorcing ourselves from the two beautiful females who have beamed upon us for seven years from the cover of THE CIRCULAR, but the progressive spirit of the age has pronounced against polygamy, and in respectful obedience thereto we cast aside the females who have abided with us so long, and hereafter will concentrate our affections upon the one virgin who has supplanted them. We think she is quite as good looking as either of the others, and certainly has larger wings. We are especially captivated with the idea that she represents the progressive spirit of the age, and is imparting new thoughts and ideas to the young workman who is gazing upon her with a wrapt admiration that has a tendency to excite the Othello in our nature. As an excuse for the workman having his back to the audience, it is suggested that he is at work on some new design, and is afraid some of the pirates in the trade will steal it. But we will leave the many beauties of our new cover to be sought out in detail by our readers.

At the head of our editorial pages we also present a new and appropriate title, which, by the courtesy of the Gorham Manufacturing Company, was designed by Mr. Wilkinson, the artist of that Company, whose work has done so much to embellish and popularize their goods. Mr. Wilkinson has hit upon a happy and graceful design, which adds much to the attractiveness of our pages. It is said that once in every seven years the human frame undergoes a complete organic change, and although THE CIRCULAR may not be generally regarded as a human being, we look upon it as a child of considerable intelligence, and so worthy of being periodically rehabilitated and dressed in fine clothes as well as any of the bifurcated species. Hence the new head and new outside, and also various other changes that will be observed running through it. It will be readily conceived that these changes involve a very considerable outlay, for those familiar with wood engraving know that work of the character referred

to requires the labor of the most skilled artists, and must be paid for accordingly. But it is our determination to keep THE CIRCULAR fully abreast-if not in advance of the improvements constantly being made in the trade, and externally at least, a worthy representative of the most artistic of all trades. We challenge the world to produce a trade paper, regularly published, that excels THE CIRCULAR in typographical appearance. It will be our ambition to make the interior of the paper worthy of such an elegant outside. To the artists we have named our thanks are due, not only for the excellent work they have done for us, but for the more than friendly interest they have shown in our welfare, and for their determination to make THE CIRCULAR unapproachable in its artistic appearance.

State Associations.

TWELVE years ago, when we first began the agitation for the formation of state associations of retail dealers, we did so because we saw growing abuses in the jobbing trade that were resulting disastrously to the retailers, and that we believed could be checked by properly directed effort on their part. Individually the dealers could do little beyond entering their verbal protests, but by concerted action, there was hope of their being sufficiently influential to carry their points. It took long and persistent urging on our part before the idea took root, but it finally did so, and there are now associations of retail dealers in half a dozen or more states. While they have not accomplished all that might have been expected of them, they have certainly effected much real good. For instance, the practice so freely indulged in by a certain class of jobbers, of sending catalogues and price lists to outsiders, offering to sell goods at retail at wholesale prices, thus robbing the retail dealers of the patronage that rightfully belonged to them, has virtually been put an end to by the united action of the state associations. The adoption by them of a uniform tariff of charges for bench work was also a most excellent thing, and the tariff so adopted might well be copied by the trade throughout the country. The social features of the annual gatherings of the associations have had a most beneficial effect upon individual members, bringing them into friendly relations with each other, and tending to knock off the rough edges of active competition, and to destroy much of its asperity. For these, and some other things, the state associations are entitled to much credit; for what they have done, and for the work that still lies before them, they should have the sympathy and active, hearty, personal support of every retail dealer. We do not regard it as any part of the mission of these associations that they should be converted into aggressive, combative trades union combinations or conspiracies, having for their objective some kindred branch of the trade. Combinations are always dangerous to the community in which they exist, whether they be of a political or a trades union nature, and are opposed to the instincts of every believer in the rights of man. But there is a vast difference between combinations to forcibly effect a desired object, and the counseling together of those interested to accomplish that object by moral suasion, and by the weight of influence that pertains to upright, reasonable men. While combinations are unlawful, the coming together in convention of the representatives of a particular calling to discuss matters of interest to them, is not only lawful, but conducive to the best interests of society. It is customary at such gatherings for the sentiments of the majority to find utterance in resolutions declaring and defining their position upon certain points presented. This we believe to be the especial province of the state associations of retail dealers. But to make such declarations effective, they should have the endorsement of the representative men whose interests are to be affected by them. Here is where the state associations are deficient to some extent. Their membership is limited as yet, and in no instance does the association number among its members a majority of the dealers of the state. That this is a lamentable fact is due largely to the mistaken zeal of some of their self-constituted leaders, who, having some hobby to ride, have alienated

those who sought to carry out the true work for which the associations were formed, and so robbed them of their co-operation. But we have always believed that the evils which may beset a household are more successfully controlled from within than from without, and that a ship should never be deserted simply because a few rats had smuggled themselves aboard with the cargo. Because the energies of the state associations have been partially misdirected, that fact does not furnish a sufficient excuse for their desertion by the best men in the trade. On the contrary, it is the very best reason why they should remain, seeking to undo whatever mischief has been done, and to carry out the true objects for which they were formed. These associations as they exist form a nucleus around which may be gathered powerful and beneficial organizations, capable of exercising a wonderful influence upon the entire trade. We hope to see every dealer of respectability included in their membership, and to this end would urge everyone in every state where they exist, to apply at once for membership, to attend every meeting and to use every endeavor to accomplish the good that it was expected would result from them. When this is done, and at each meeting there is a full and fair representation of the retail dealers of the state, there will be no danger to apprehend from mistaken zealots or from vicious counsels.

Since the organization of the state associations there has come an unseemly after-birth that has attached itself to them like a hungry parasite, and is feeding upon their life blood. This parasite is called the National Guild. When it was first started we hoped some good might come of it, and gave it words of encouragement. But if it ever possessed any latent energy that warranted its being brought into existence, that energy has been so misdirected that nothing is left but an ugly excrescence, feeding upon the body of the state associations. It has as yet done nothing entitling it to a continued existence, and the sooner its supplies are cut off and its life terminated, the better it will be for the associations and the trade in general. It may have served to satisfy the ambition of a few self-seeking officers, but no good reason has yet been put forth why they should subsist at the expense of the retail dealers. The National Guild levies a contribution of fifty cents a year upon the members of every state association, but what good end is served with the fund so raised has never yet been made apparent. We do not question but this tax, small as it may be, has served to deter many dealers from joining the state associations, because they were unable to see why such tribute should be imposed upon them. Experience has demonstrated that the state associations are ready to co-operate with one another without the intervention of any other body or individual, and that, consequently, a National Guild or National Guild officers are superfluous and expensive luxuries. We hope the state associations will have the courage to refuse further contributions to this insatiable monstrosity.

An existing abuse, for the correction of which every retail dealer should be willing to lend his voice and active influence, and which is essentially within the purview of the state associations, is the practice largely indulged in by some manufacturers as well as jobbers, in selling goods at wholesale prices to outsiders. Indeed, some manufacturers make a cheap line of goods especially for this trade, hoping thereby to tempt them to further purchases and to a more pronounced competition with the retail dealers. The goods made specially for this outside trade are of such a cheap quality that no regular dealer having a reputation to protect would handle them. The hardware dealers, the gents' furnishing goods houses and the milliners can sell them, for they are not required to give any guarantee with them, and have no reputations as jewelers that can be affected by their dealing in these spurious goods. But they get a taste of the trade, and finding that by keeping goods of this kind they attract customers, they enlarge their lines and become active competitors for the retail trade. Still they do not occupy the position of reputable dealers in jewelry; they do not pretend to be judges of the goods they handle, and their responsibility regarding them ends when they have pocketed their customers' money. Not so with the legitimate dealer; he has a reputation as a jeweler at stake, and his representations are regarded as

a guarantee; if the goods are not satisfactory he must refund the purchase money. There are quite a number of manufacturers and jobbers who deliberately seek this trade, and, after selling to the legitimate dealers, will load up outsiders in the same town with the same or similar goods he has sold the dealer and at the same prices. As the outsider only uses these goods as a bait to attract customers for his other wares, he can afford to cut prices, and so an illegitimate competition is begot, against which the responsible dealer cannot make headway. This is an abuse that the state associations should protest against in terms that will command attention. Every dealer in the land suffers to a greater or lesser extent from this unbusiness-like practice, and, for the sake of putting an end to it, they should join hands with the associations. To combat this one evil and to compel manufacturers and jobbers to respect the rights of retail dealers in this regard, will furnish employment for these associations for some time to come. They can devote themselves to no more needed work, and we hope to see them enter upon the crusade with energy and a determination to win. In such a work they will have the sympathy of every honorable man in the trade. Beside this great and crying evil all others sink into insignificance, and until it is eradicated the associations should ignore the lesser abuses. But it is useless for them to enter upon this campaign, which will be a protracted one, until they themselves command the confidence and sympathy of the entire trade. To the end that they may do this they should use every exertion to enroll every reputable dealer in their respective states as members of their organizations.

The Customs Tariff on Precious Stones.

THE TARIFF Commission appointed by Congress to revise the tariff and to suggest changes, recommended, among other things, an advance of duty on precious stones from ten per cent. ad valorem to twenty-five per cent. ad valorem. This recommendation was adopted by the Committee of Ways and Means for presentation to Congress for final adoption. No effort was made on the part of any member of the Tariff Commission to ascertain the effect such an advance would have upon the trade, nor were any of the importers invited to a consultation on the subject, but in an arbitrary, unintelligent manner, the suggestion was accepted, and bid fair to be rushed through Congress with the same uninquiring spirit. The importers were naturally alarmed, and at a meeting held one afternoon the following petition was drawn up and signed:

NEW YORK, JANUARY 5, 1883.

To the Committee of Ways and Means of the U. S. House of Representatives:

The undersigned are all engaged in business as *importers of diamonds and other precious stones.*

Your petitioners have learned that it is proposed to amend the tariff and to advance the duty on precious stones from *ten per cent. ad valorem to twenty-five per cent. ad valorem.* We beg to represent to you that such an advance in the customs duty would be a fatal blow dealt to a large and growing business in this country, wherein are employed large amounts of capital and many people. Our objections to the proposed increase of duties may be briefly stated as follows:

1st. Owing to the valuable character of precious stones, their small bulk, and the readiness with which they can be concealed, they offer a great temptation to smugglers. To increase the rewards to be obtained from an illicit traffic, is to increase the volume of that traffic.

2d. Under the present tariff frequent cases of smuggling are reported; but under an increased tariff smuggling would be the rule to such an extent that honest importers could not compete in the markets of the country against goods so smuggled, with goods upon which the tariff had been paid. As a consequence, reputable merchants would be driven out of the business of importing precious stones, and unscrupulous and law-defying men would obtain control of the traffic.

3d. Under the ten per cent. duty, a greater portion of the taxes due the government on importations of precious stones is collected with little trouble or expense, because the business is mainly in the hands of reputable merchants. Under an advanced tariff the government would be subjected to greater expense in watching smug-

glers, and would obtain less revenue than it now does. Rogues would be substituted for honorable merchants in the business of bringing precious stones to this country.

4th. The facilities for intercommunication between the United States and Europe are now so great that many thousands of tourists pass to and fro every year. With a high tariff on precious stones, necessitating high prices in this country, and the facilities with which they can be concealed, many tourists would buy goods of this class in Europe, trusting to their adroitness to evade the customs officers on this side of the ocean. In consequence, the traffic in precious stones would be transferred from this country to Europe, and the men and capital now employed here in importing them and preparing them for the market would be left idle.

5th. The jewelry trade in general suffers greatly already from the illicit traffic in jewelry carried on along the Canadian border. Should the duty on precious stones be advanced as proposed, this evil would be greatly aggravated, involving the Government in much expense to increase and maintain its customs service on the northern border of the United States.

6th. Under the present duty the temptation for smuggling is not sufficient to defeat the honest purposes of reputable importers and merchants, but we firmly believe that any increase above ten per cent. *ad valorem* would have a tendency to promote smuggling, and to destroy an industry from which the Government now derives a considerable revenue.

Tiffany & Co., Randel, Baremore & Billings, Louis Strasburger & Co., D. H. Wickham & Co., W. S. Hedges & Co., E. Aug. Neresheimer, D. & M. Bruhl, Albert Lorsch, Theo. B. Starr, Alfred H. Smith & Co., Saunders & Ives, Philip Bissinger & Co., Eisenman Bros., Victor Bishop & Co., Chas. Wm. Schumann, D. B. Citroen & Co., Kuhn, Doerflinger & Co., L. & M. Kahn, Henle Bros., Baldwin, Sexton & Petersen, Taylor Bros., S. Eichberg, Kossuth Marx & Co., Falkenau, Oppenheimer & Co., Oppenheimer Bros. & Veith, M. Fox & Co., of New York; M. W. Galt, Bros. & Co., Washington, D. C.; J. E. Caldwell & Co., Philadelphia; Shreve, Crump & Low, Bigelow, Kennard & Co., Boston; Bailey, Banks & Biddle, Philadelphia; Mermod Jaccard & Co., Eugene Jaccard Jewelry Co., L. Bauman Jewelry Co., St. Louis; Duhme & Co., Cincinnati; M. S. Smith & Co., Detroit; Hennegan, Bates & Co., Justis & Armiger, Baltimore; Giles, Bro. & Co., N. Matson & Co., B. F. Norris & Co., W. B. Clapp, Bro. & Co., Caleb Clapp & Co., Benj. Allen & Co., H. F. Hahn & Co., S. Hyman & Co., C. D. Peacock, F. E. Morse & Son, Chicago.

Algernon S. Sullivan, an eminent lawyer of this city, was immediately retained to appear before the Committee of Ways and Means, present the petition, and argue the case in the interests of the importers. Mr. Sullivan started for Washington the same night, met the Committee, and in a forcible manner presented the case to them in a light in which the members had never viewed it. To make the story short, Mr. Sullivan was entirely successful in his mission, the Committee voting to rescind its action, and to leave the duty on precious stones at ten per cent. *ad valorem*. This will be the recommendation the Committee will make to the House of Representatives, and it is not apprehended that any attempt will be made in the House to change it. The action of Congress, however, will be carefully observed, and such measures taken to protect the trade as may be deemed necessary.

THERE IS nothing like free, jovial, social intercourse to "smooth the wrinkled front" of business care and anxiety, and nothing more promotive of kindness of heart, forbearance and tolerance of the shortcomings of others. Men who touch legs under the convivial mahogany, enjoying a good dinner and its concomitants, are more apt to feel a friendly interest in each other thereafter. In the hurryscurry of our active business lives, and the eternal anxiety of money getting, we are too apt to overlook those social amenities due from one to another, and to become hide bound in our own exclusiveness. This leads to moroseness, begets a suspicious, cynical disposition, and is the source of much bitterness existing between competitors in business. There is nothing in a business competition that should necessarily make men enemies, provided it is conducted on business principles, and it is more likely to be so conducted if the rival dealers make friends and maintain pleasant social relations. We have known many instances where competitors were in the habit of abusing each other roundly until they became acquainted, when they found that

each was a pretty good fellow and worthy to be called a friend. Men in business are simply exercising their God-given prerogative to make a living for themselves and those dependent upon them, and it is in the nature of things that the lives of many should run parallel. When within speaking distance it is better and more social to be familiar than to jog along in a stolid and gloomy fashion.

We observe with pleasure that A. J. Warner & Co., of Minneapolis, are evidently of our opinion on this subject, for they recently gave a reception to the jewelers of that city, which is spoken of as having been most enjoyable. There was an excellent repast, prepared by a resident caterer, and embracing all the delicacies of the season. All the jewelers of the city were present, and we may be certain that while hobnobbing over their wine, or swapping stories over their fragrant Havanas, all the animosities engendered by business rivalries were forgotten, and that they separated with a better opinion of each other than they ever entertained before. We would suggest that this idea be improved upon, and that the jewelers of the rival cities of St. Paul and Minneapolis meet together in social conclave at least once a year, and, while refreshing the inner man with grateful viands and those cheering beverages which exhilarate but do not intoxicate, cultivate a kindlier feeling for their fellow men, but especially for their brother jewelers. We would be glad to hear of such reunions within the trade in every section of the country, confident that it would promote a better feeling in the business relations that should exist among those engaged in the same industry. The example of Warner & Co. is one that may be profitably imitated by jewelers in other localities.

Gold, Silver and Nickel Plating with Special Reference to the Wants of the Watchmaker.

[BY PAUL HIEHLE, IN THE *Notiz Kalender* OF M. GROSSMANN.]
SIMPLE METHOD FOR REGILDING UNSIGHTLY WATCH PARTS.

THE WATCHMAKER very frequently receives watches for repairs, which, by too energetic a use of chalk and cleaning brush, have assumed an appearance that is anything but handsome to the eye of a neat workman; its once attractive gilding having disappeared in part or altogether. Many a skilful watchmaker in viewing such a disfiguration, has doubtlessly wished that he could restore the good appearance by regilding, without being able to do it, because he did not know a simple and at the same time efficacious method for producing such a gilding.

Impelled by the solicitations of Mr. Grossmann, I have endeavored to treat of this branch of gilding and silvering in as explicit a manner as possible, so that even the less skilled workman, or one who has never engaged in such an undertaking, may be capacitated to work according to the instructions given.

The widest-embracing materials are gilt; among the non-metallic substances, we may mention glass, gypsum, wood, ivory, leather, pasteboard, paper, and woven fabrics even; among the metals we have principally brass, German silver, copper, iron, steel, and silver. The following remarks will apply only to the gilding of metals, and principally to that of brass, wherefore they will be peculiarly fitted for the purposes of the watchmaker.

There are five different methods for gilding, which again can be separated into various subdivisions; it would lead us too far, however, to enumerate them. Until 1840, these were only known:

1. *Five gilding*, which chiefly consists in combining gold and mercury into an amalgam, and applying it to the article to be gilt, after which the mercury is expelled by evaporation, in consequence of a strong heating, whereby the gold remains as a more or less heavy coating.

2. *Gold gilding by rubbing*, by which the gold is reduced to as fine a state as possible (gold rags), in which form it easily adheres to metallic surfaces, and soon obtains a handsome luster by rubbing.

3. *Wet gilding*, by which is understood all those processes in

which the gold is applied in a state of solution. Galvanic as well as contact gilding actually belongs to this category. By wet gilding, however, is understood the older method of applying the gold in combination with a mercury double salt, by which only indifferent results were obtained.

Considering the costliness of the gold, its beauty and resisting capacity, it is easily understood that ways and means were sought for a long time, to apply it in as thin a layer as possible, which at the same time should adhere in a durable manner. When the discovery was made in 1840, that the galvanic current was capable of complying with these several demands, consequently we have—

4. *Galvanic gilding.*—This method is the most universally spread, and owing to its ease of execution, and possibility to quickly produce the heaviest as well as thinnest coating, it has almost crowded out all the other older methods. In the gold plating by this method, a physico-chemical process takes place. The apparatus of the former here is the element, that of the latter the decomposing cell or the vessel with the suitable alkaline gold salt solution, in which latter parts are withdrawn by a therein suspended metallic plate (anode) by the galvanic current, which are absorbed by the fluid, and by this again deposited upon the article to be coated (cathode).

Since it would not be profitable in many cases, especially when small articles are concerned, to employ the entire apparatus necessary for galvanic gilding, we make use of the last method:

5. *Contact gilding.*—Although this is also a galvanic gilding, still, a very feeble current only operates in this instance, and beside a porcelain or well-glazed earthen dish, no special apparatus is necessary. This last mentioned process, consequently, would be the one best adapted for our purposes, and we will therefore treat it at length.

The first work necessary to be done is the preparation of the gold bath suitable for the purpose, and the first step would be to prepare the requisite quantity of auric chloride or chloride of gold, which is to be done as follows:

Either prepare or procure two pennyweights of pure gold; hammer or roll it as thin as paper; after the last annealing, a process necessary for removing any still adhering traces of fat and other organic substances, the sheet is cut into little pieces, which are to be rolled up with a pair of tweezers. This is done to prevent the pieces of layering one upon the other, which would be the case if they were left flat; they thereby offer more surface to the operation of the acid subsequently to be added. Now take a chemist's flask, or, what is still better, an evaporating dish, pour the previously prepared rolls into it, and over them pour a quantity of about 50 grams (1 oz., 12 dwt., 3.6 grains) common commercial nitro-muriatic acid (this can also be prepared from 1 part nitric and 3 parts muriatic acid); and hasten to remove the dish as quickly as possible into open air or a thoroughly drawing chimney, because heavy chlorine vapors evolve hereby, which are not alone very disagreeable and unhealthy, but also entirely out of place in a watchmaker's shop, because they cause the rusting of steel parts in a very short time. It is best, therefore, to perform the work as aforesaid. When the gold has been dissolved, which generally occurs in a very short time, the handsome gold-yellow fluid is evaporated, to be done in the following manner: Place the flask or dish containing the solution either into a sheet of sheet iron, or, what is still better, into an iron vessel filled with medium fine sand, whereby on the one hand a more uniform heating of the dish is effected, and, on the other, the operation of the heat upon the sides of the dish is prevented, by the action of which some of the chloride could easily be destroyed.

He who wished to be very painstaking, had better undertake the evaporation of the acid in the water bath instead of a sand bath; a mishap of the process is almost impossible hereby, but the process is more tedious. Indifferent, which method is employed, the vessel containing the dish with the solution is placed upon a gentle coal fire, or, if operating simply with very small quantities, above an alcohol flame, and let the fluid evaporate gradually, whereby it

will assume hyacinth red color; continue to heat until the whole has become dark brown, and is of a syrupy consistency. When this shows itself, remove the vessel, together with dish, at once from the fire, permit the mass to crystalize and cool, and the chloride of gold is ready. Special attention must be paid not to evaporate the fluid to dryness, because if heat is applied too long, the gold chloride will pass into the insoluble protochloride, and next into the metallic condition. In such a case, the mass must be treated again with nitro-muriatic acid, to be followed by evaporation. Many buy this acid and store it in this condition. I would advise no one to do it, however, because both acids operate upon each other, even in absence of a metal, and the active part of the mixture, the chloride, volatilizes, leaving an almost passive fluid behind. It is much better, therefore, to prepare the mixture only when to be used. A few prepare the chloride of gold also by means of a mixture of nitric acid and sal ammoniac or salt; this is a bad old method, and used almost exclusively to-day by porcelain painters.

The gold chloride having crystalized into handsome, long needles, while still in the flask, is next poured over with a little distilled water, in which it dissolves at once. This fluid is now poured upon a filter of clean white blotting paper, placed within a glass funnel inserted in the mouth of a small clean bottle. If the operator has no funnel frame, a little paper must be laid between the funnel and neck of bottle to allow the air to escape, so that the fluid upon the filter can enter. This filtering is for the purpose of removing the chloride of silver which has formed from the trace of silver contained even in the purest commercial gold.

During the time that this filtering progresses, we engage in the second part of the task, that of preparing the bath itself. To manufacture this, we raise 1 liter (1.0567 quarts) distilled water slowly to boiling in a porcelain, or what is better and simpler, in a well-enamelled iron vessel, and add, before it comes to boiling, one after the other, 60 grams (1 oz., 18 dwt., 139 grains) of yellow prussiate of potash, 28 grams (18 dwt.) carbonate of potash, and 42 grams (1 oz., 7 dwt.) culinary salt, and permit it to boil for two or three minutes, while stirring with a glass rod. The solution of the gold chloride, which has been filtered meanwhile, is slowly added to the boiling liquid, while continually stirring with the glass rod. When done, it is permitted to boil about two or three minutes, after which the fluid is filtered again into a bottle provided with a well-ground glass stopper, in which the ready bath may be stored for future use, for which the fluid is again to be heated to nearly boiling. I will hereafter explain the details for using it.

When the bath necessary for gilding has been prepared ready for use in the afore-described manner, and before the articles to be gilt are placed in it is indispensably necessary that are perfectly clean, because the slightest trace of any foreign body often suffices to disturb the adhesion of the two metals, it may even destroy it altogether. The various manipulations necessary for effecting a perfect cleansing, is known as

BOILING OUT.

This boiling out varies according to the nature of the metals; it is most exactly in the case of copper and its alloys (brass, tombac, bronze, etc.), and these interest us the most for our purposes. The following is a description of these operations for new articles, and their modifications, when regilding old ones, will follow afterward.

This boiling out is divided into five processes: 1. Glow heating, or cleansing with potash; 2. Dipping; 3. Treating with nitric acid and lamp black; 4. Treating with the acid mixture for lustring or matting; 5. Treating with nitrate of mercury.

1. *Cleansing.*—The article to be gilt is generally covered with fat, dirt, and oxide, due to the several working processes, such as filing, grinding, polishing with oil, etc., or simply handling with bare hands. In order to destroy these adhering organic substances, it is heated to weak red heat upon a gentle charcoal fire. In cases, however, where the hardness of the single parts is indispensable, such as the different parts of a watch, the articles are boiled for some time in a

strong potash or soda solution, whereby the fatty parts are saponified, and thereby made soluble.

2. *Dipping*.—The articles, freed either by glowheating or by an alkali from any fatty adhesions, are now at once dipped into a mixture of 12 parts sulphuric acid, of 66°, and 88 parts common water. The parts may remain optionally long in this pickle, without anticipating the fear that they might be attacked too strongly; however, it is indispensably necessary not to take them out of the pickle until the black film of copper oxide, with which they became covered after glow heating, has completely disappeared, and only an ochre-yellow film of copper protoxide remains, which is no longer attacked by the sulphuric acid. It is well to remark right here, that the pieces laid into the pickle must in no manner contain iron or steel parts, since these would be either completely dissolved, or at least rendered useless, from which also follows that no iron instrument (hooks, wire, tweezers, etc.) must be used for removing the articles from the pickle. Those cleansed by boiling with potash or soda are dipped only after a previous careful washing and rinsing, and I cannot lay sufficient stress on the necessity of rinsing and cleaning the articles as well before as after the operations to be described hereafter, and to observe, even down to the minutest details, the most scrupulous cleanliness, since with a bad dipping, even if followed by the best bath, the results would only be indifferent. Next follows:

The treatment with nitric acid and lamp black.—After a previous washing, the articles are dipped in a mixture consisting of 100 parts nitric acid, of 30°, 1 part cooking salt, and 1 part glow heated lamp black. This acid attacks the immersed metals very strongly, wherefore they must not be longer left in it than a few seconds.

As soon as they are taken out of the acid, they are to be thrown into a neighboring larger vessel with clean water, in which they are freed from all adhering acid parts by being moved around therein. They will now show a handsome bright gold color, and it might be supposed that they are liberated from all adhering dirt and foreign bodies. This, however, is not the case, because if in this condition they are dipped into a bath for wet gilding, they become completely black, and show no metallic luster. If the articles, after being removed from the acid, are not washed at once, but left in contact with the air only for a short time, a green froth will at once form upon their surface, and voluminous orange yellow vapors of nitrous acid will evolve, which shows the complete decomposition of the moistening acid. After the vapors have disappeared, the pieces remain black, even after rinsing, in consequence of the formation of a basic copper salt, which is insoluble in water. The lamp black in this bath only serves for the purpose of converting a small part of the nitric into nitrous acid by the influence of its carbon; this nitrous acid combines with the chlorine contained in the table salt, and thus forms a small part of chloro-nitrous acid, which is necessary for this operation.

This process having succeeded to satisfaction, we undertake the fourth:

a. *The lustring*.—In order to give the articles a handsome lustrous surface, they are dipped for one or two seconds, while moving them constantly to and fro into a mixture, prepared at least on the previous evening, consisting of nitric acid, of 36°, 100 parts by volume; sulphuric acid, of 66°, 100 parts by volume; table salt, 1 part by volume. After having been taken out of this bath, the articles must again be well rinsed in plenty of clean water, as already stated.

Attention must be directed to the fact that it is not by any means indifferent in what manner the different components are placed together. The nitric acid must always be brought first into the vessel intended for its reception, and the others follow only afterward, since the sulphuric acid, on account of its greater specific gravity, would remain on the bottom, without mixing.

When mixing the acids, especially when adding the salt, an important development of heat takes place, and a large quantity of obnoxious vapors escape, which must not be breathed in. It is advisable, therefore, to perform this work either in open air or in a well drawing chimney.

In cases demanding haste, a fluid prepared on the same day might also be used, but attention must be paid to previously cooling it either in ice or water before use. If no lustrous, but a mat surface is desired, the above part of the operation is omitted, and we proceed to the

b. *Matting*.—The bath for this purpose is prepared in the following manner: Nitric acid, of 36°, 200 parts of volume; sulphuric acid, 66°, 100 parts by volume; table salt, 2 parts by volume; sulphate of zinc, 3 parts by volume.

The articles may be left immersed in this cold mixture for from 5 to 20 minutes, without anticipating injury; the obtained mat corresponds to the length of the operation. The articles, when removed from the bath, and rinsed with much water, have an unsightly, earthy appearance, which is very easily corrected, however, by immersing them for one minute into the acid mixture used for lustring; it must be done with dexterity, otherwise the handsome mat would be destroyed. To obtain a first-class adhering gold coating, we finish with the last process:

c. *Heating with mercury nitrate*.—This operation has been borrowed from the process of fire gilding, and has repeatedly demonstrated its great importance during my practice. It consists in dipping the articles, cleansed in the afore-described manner, for 1 or 2 seconds into a fluid composed as follows, until they have assumed a silver-white appearance: distilled water, 1 kilogram; nitrate of mercury, 0.4 gram; nitric acid, 1 gram.

When the mercury nitrate is placed into the water, a thick, whiteish yellow turbidity will arise at once, which disappears again upon the addition of the acid; a nearly water-clear fluid remains, which, when used, must each time be well shaken. When this operation has been ended, the articles are ready for being placed into the gilding bath, and they are kept meanwhile in clean water, in order to guard them against dust and dirt. And above all, do not touch them with bare fingers.

This rather tedious manner of cleansing, however, would be far too long for the watchmaker for regilding unsightly parts of watches, nor would it be necessary. For this purpose it is sufficient to thoroughly cleanse them only in the above-described manner by means of a potash or soda solution, when they can at once be placed into the bath, and bad results are hardly ever obtained. Should it occur, however, at some time or other, that the gold would not sufficiently adhere, employ the last-named operation and dip the articles into a mercury oxide solution, which will result in a desirable manner in every instance.

(To be Continued.)

THE NUPTIAL present of the Province Saxony for the Prince and Princess Wilhelm of Prussia, and which at the festival was only donated in design, has been finished. The central piece, a silver cup about 1 meter (39.37 inches), has been completed some time ago by the firm of Sy & Wagner. It was modeled by the sculptor Zacharias, and is surrounded by a border representing a marriage procession, embellished with exquisite figurative and ornamental adornments in relief, gilding and settings of colored jewels, of an admirable effect. The three-story buffet, destined for receiving this *chef d'œuvre*, was carved out of walnut by a sculptor of Magdeburg, assisted by architect Schütz, and, of course, is ornamented in the highest style of wood carving; while paintings at either side of the main division lend an additional effect. They consist of two allegorical female figures, standing in half-round niches. They represent the two chief branches of the Province Saxony, mining and agriculture. The former has the hammer in the right hand, while the left raises the ray-encircled gems, with the mining lamp in the diadem; the other one rests a foot upon the plow, carrying a pigeon in the right hand, while embracing a cornucopia with the left arm. The long front of the Merzeburg Castle is painted in a lower compartment, and in the others, respectively, the domes of Magdeburg and Erfurt, with other representations also of local interest. The goldsmith's work is said to rival any of the productions of the famed middle age.

John Harrison the Chronometer Maker.

Continued from page 404.

EVERYONE knows the beautiful machinery of a timepiece, and the perfect tools required to produce such a machine. Some of these Harrison procured in London, but the greater number he produced for himself. Many entirely new adaptations were required for his chronometer. Wood could no longer be employed, and he had therefore to teach himself to work accurately and minutely in brass and other metals. Having been unable to obtain any assistance from the Board of Longitude, he was under the necessity, while carrying forward his experiments, of maintaining himself by working at his trade of a carpenter and joiner. This will account for the very long period that elapsed before he could bring his chronometer to such a state that it might be tried with any approach to certainty in its operations.

Harrison, besides his intentness and earnestness in respect of the great work of his life, was a cheerful and hopeful man. He had a fine taste for music, and organized and led the choir of the village church, which attained a high degree of perfection. He invented a curious monochord, which was not less accurate than his clocks in the mensuration of time. His ear was distressed by the ringing of bells out of tune, and he set himself to remedy them. At the parish church of Hull, for instance, the bells were harsh and disagreeable, and by the authority of the vicar and church wardens he was allowed to put them into a state of exact tune, so that they proved entirely melodious.

But the great work of his life was his marine chronometer. He found it necessary, in the first place, to alter the first mover of his clock to a spring wound up, so that the regularity of the motion might be derived from the vibrations of balances, instead of those of a pendulum in a standing clock. Mr. Folkes, President of the Royal Society, when presenting the gold medal to Mr. Harrison in 1749, thus describes the arrangement of his new machine. The details were obtained from Harrison himself, who was present. He made use of two balances situated in the same plane, but vibrating in contrary directions, so that the one of these being either way assisted by the tossing of the ship, the other might constantly be just so much impeded by it at the same time. As the equality of the times of the vibrations of the balance of a pocket-watch is in a great measure owing to the spiral spring that lies under it, so the same was here performed by the like elasticity of four cylindrical springs or worms, applied near the upper and lower extremities of the two balances above described.

Then came in the question of compensation. Harrison's experience with the compensation pendulum of his clock now proved of service to him. He proceeded to introduce a similar expedient into his proposed chronometer. As is well known to those who are acquainted with the nature of springs moved by balances, the stronger those springs are the quicker the vibrations of the balances are performed, and *vice versa*; so it follows that those springs, when braced by cold, or when relaxed by heat, must of necessity cause the timekeeper to go either faster or slower, unless some method could be found to remedy the inconvenience.

The method adopted by Harrison was his compensation balance, doubtless the backbone of his invention. His "thermometer kirb," he himself says, "is composed of two thin plates of brass and steel, riveted together in several places, which, by the greater expansion of brass than steel by heat and contraction by cold, becomes convex on the brass side in hot weather and convex on the steel side in cold weather; whence, one end being fixed, the other end obtains a motion corresponding with the changes of heat and cold, and the two pins at the end, between which the balance spring passes, and which it alternately touches as the spring bends and unbends itself, will shorten or lengthen the spring, as the change of heat or cold would otherwise require to be done by hand in the manner used for regulating a common watch." Although the method has since been improved

upon by Leroy, Arnold, and Earnshaw, it was the beginning of all that has since been done in the perfection of marine chronometers. Indeed, it is amazing to think of the number of clever, skilful and industrious men who have been engaged for many hundred years in the production of that exquisite fabric—so useful to everybody, whether scientific or otherwise, on land or sea—the modern watch.

It is unnecessary here to mention in detail the particulars of Harrison's invention. These were published by himself in his "Principles of Mr. Harrison's Timekeeper." It may, however, be mentioned that he invented a method by which the chronometer might be kept going without losing a second of time. This was during the process of winding up, which was done once in a day. While the mainspring was being wound up a secondary one preserved the motion of the wheels and kept the machine going.

After seven years' labor, during which Harrison encountered and overcame numerous difficulties, he at last completed his first marine chronometer. He placed it in a sort of moveable frame, somewhat resembling what the sailors call a "compass jumble," but much more artificially and curiously made and arranged. In this state the chronometer was tried from time to time on a large barge on the river Humber, in rough as well as in smooth weather, and it was found to go perfectly, without losing a moment of time.

Such was the condition of Harrison's chronometer when he arrived in London with it in 1735, in order to apply to the commissioners appointed for providing a public reward for the discovery of the longitude at sea. He first showed it to several members of the Royal Society, who cordially approved of it. Five of the most prominent members—Dr. Halley, Dr. Smith, Dr. Bradley, Mr. John Machin, and Mr. George Graham—furnished Harrison with a certificate, stating that the principles of his machine for measuring time promised a very great and sufficient degree of exactness. In consequence of this certificate, the machine, at the request of the inventor and at the recommendation of Sir Charles Wagner, First Lord of the Admiralty, was placed on board a man-of-war, and carried, with Mr. Harrison, to Lisbon and back again. The chronometer was not affected by the roughest weather, or by the working of the ship through the vast rolling waves of the Bay of Biscay. By means of its exact measurement of time an error of almost a degree and a half (or ninety miles) in the computations of the reckoning of the ship was corrected at the mouth of the Channel.

Upon this first successful trial of his chronometer the Commissioners of Longitude gave Harrison the sum of 500*l.*, on condition that he should proceed to make further improvements in his machine. Mr. George Graham urged that the Commissioners should award him double the amount; but this was refused. At the recommendation of Lord Monson, however, Harrison accepted the sum as a help towards the heavy expenses and labor which he had incurred, and was about to incur, in perfecting the machine. He was instructed to make his new chronometer of less dimensions than the first, which was thought too cumbersome and to occupy too much space on board.

He accordingly proceeded to make his second chronometer. It occupied a space of about only half the size of the first. He introduced several improvements. He lessened the number of the wheels, and thereby diminished friction. But the general arrangement remained the same. The second machine was finished in 1739. It was much more simple in its arrangement, and much less cumbersome in its dimensions. It answered even better than the first, and though it was not tried at sea its motions were sufficiently exact for finding the longitude within the nearest limits proposed by Parliament.

Not satisfied with his two machines, Harrison proceeded to make a third. This was of an improved construction, and occupied still less space, the whole of the machine and its apparatus standing on an area of only four square feet. It was in such forwardness in January, 1741, that it was exhibited before the Royal Society, and twelve of the most prominent members signed a certificate of "its great and excellent use, as well for determining the longitude at sea as for correct-

ing the charts of the coasts." The testimonial concluded: "We do recommend Mr. Harrison to the favor of the Commissioners appointed by Act of Parliament as a person highly deserving of such further encouragement and assistance as they shall judge proper and sufficient to finish his third machine." The Commissioners granted him a further sum of 500*l.* accordingly. Harrison was now reduced to necessitous circumstances by his continuous application to the improvement of the timekeepers. He had also got into debt, and required further assistance to enable him to proceed with their construction.

Although Harrison had promised that the third machine would be ready for trial on August 1, 1743, it was not finished for some years after. In June, 1746, we find him again appearing before the Board, asking for further assistance. While proceeding with his work he found it necessary to add a new spring, "having spent much time and thought in tempering them." Another 500*l.* was voted to enable him to pay his debts, to maintain himself and family, and to complete his machine.

Three years later he exhibited his third machine to the Royal Society, when he was awarded the Gold Medal for the year. In presenting it Mr. Folkes, the President, said to Mr. Harrison, "I do here, by the authority and in the name of the Royal Society of London for the improving of natural knowledge, present you with this small but faithful token of their regard and esteem. I do, in their name, congratulate you upon the successes you have already had, and I most sincerely wish that all your future trials may in every way prove answerable to these beginnings, and that the full accomplishment of your great undertaking may at last be crowned with all the reputation and advantage to yourself that your warmest wishes may suggest, and to which so many years so laudably and so diligently spent in the improvement of those talents which God Almighty has bestowed upon you, will so justly entitle your constant and unwearied perseverance."

Mr. Folkes, in his speech, spoke of Mr. Harrison as "one of the most modest persons he had ever known." In speaking of his own performances he has assured me that, from the immense number of diligent and accurate experiments he has made, and from the severe tests to which he has in many ways put his instruments, he expects he shall be able with sufficient certainty, through all the greatest variety of seasons and the most irregular motions of the sea, to keep time constantly, without the variation of so much as *three seconds in a week*, a degree of exactness that is astonishing and even stupendous, considering the immense number of difficulties, and those of very different sorts, which the author of these inventions must have had to encounter and struggle withal."

Although it is common enough now to make first-rate chronometers—sufficient to determine the longitude with almost perfect accuracy in every clime of the world—it was very different then, at the time that Harrison was occupied with his laborious experiments. Although he considered his third machine to be the *ne plus ultra* of scientific mechanism, he nevertheless proceeded to construct a fourth timepiece, in the form of a pocket watch about five inches in diameter. He found the principles which he had adopted in his larger machines to apply equally well in the smaller; and the performances of the last surpassed his utmost expectations. But in the meantime, as his *third* timekeeper was, in his opinion, sufficient to supply the requirements of the Board of Longitude as respected the highest reward offered, he applied to the Commissioners for leave to try that instrument on board a royal ship to some port in the West Indies, as directed by the statute of Queen Anne.

It was not until March 12, 1761, that he received orders for his son William to proceed to Portsmouth, and go on board the "Dorsetshire" man-of-war, to proceed to Jamaica. But another tedious delay occurred. The ship was ordered elsewhere, and William Harrison, after remaining five months at Portsmouth, returned to London. By this time John Harrison has finished his *fourth* timepiece—the small one—in the form of a watch. At length William Harrison

set sail with this timekeeper from Portsmouth for Jamaica in the "Deptford" man-of-war, on November 18, 1761, and returned to England on March 26, 1762. On the arrival of the ship at Port Royal the timekeeper was found to be only five and one-tenth seconds in error, and during the voyage of over four months, on its return to Portsmouth in the "Merlin," it had only erred one minute fifty-four and a half seconds. In the latitude of Portsmouth this only amounted to eighteen geographical miles, whereas the Act required that it should only come within the distance of thirty miles or minutes of a great circle. One would have thought that Harrison was now clearly entitled to his reward of 20,000*l.*

But the delays interposed by government are long and tedious. Harrison had accomplished more than was requisite to obtain the highest reward. It was necessary for him to petition Parliament on the subject. Three reigns had passed: Anne had died; George I. and George II. had reigned and died; and now in the reign of George III. an Act was passed enabling Harrison to obtain the sum of 5,000*l.* immediately as part of the reward. But the Commissioners differed about the tempering of the springs. They required a second trial of the timekeeper. Two more years passed, and Harrison's son again departed with the instrument on board the "Tartar" for Barbadoes on March 28, 1765. He returned in about four months, during which time the instrument enabled the latitude to be ascertained within *ten* miles, or *one-third* the required geographical distance.

Harrison memorialized the Board again and again. In the following September they virtually recognized his claims by paying him on account 1,000*l.* In February, 1765, the Board entered a minute on their proceedings that they were "unanimously of opinion that the said (Harrison's) timekeeper has kept its time with sufficient correctness, without losing its longitude in the voyage from Portsmouth to Barbadoes beyond the nearest limit required by the Act of 12th of Queen Anne, but even considerably within the same." They would not give him the necessary certificate, though they were of opinion that he was entitled to be paid the full reward.

Harrison was now becoming old and feeble. He had attained the age of seventy-four. He had spent forty years in working at the chronometers. He was losing his eyesight and could not afford to wait much longer.

Full little knowest thou, who hast not tried,
What hell it is in suing long to bide;
To lose good days that might be better spent;
To waste long nights in pensive discontent;
To spend to-day, to be put back to-morrow,
To feed on hope, to pine with fear and sorrow.

But Harrison had not lost his spirit. Or May 30, 1765, he addressed another remonstrance to the Board, containing much stronger language than he had up to this time used. "I cannot help thinking," he said, "but I am extremely ill-used by gentlemen who I might have expected a different treatment from; for if the Act of the 12th of Queen Anne be deficient, why have I so long been encouraged under it, in order to bring my invention to perfection? And, after the completion, why was my son sent twice to the West Indies? Had it been said to my son, when he received the last instruction, 'There will, in case you succeed, be a new Act on your return, in order to lay you under new restrictions, which were not thought of in the Act of the 12th of Queen Anne'—I say, had this been the case I might have expected some such treatment as I now meet with.

"It must be owned that my case is very hard; but I hope I am the first, and for my country's sake I hope I shall be the last, that suffers by pinning my faith upon an English Act of Parliament. Had I received my just reward—for certainly it may be so called after forty years' close application of the talent which it has pleased God to give me—then my invention would have taken the course which all improvements in this world do; that is, I must have instructed workmen in its principles and execution, which I should have been glad of an opportunity of doing. But how widely this is different from what is now proposed, viz. for me to instruct people that I know nothing of, and such as may know nothing of mechanics; and, if I do not make them understand to their satisfaction, I may then have nothing!

"Hard fate indeed to me, but still harder to the world, which may be deprived of this my invention, which must be the case, except by my open and free manner in describing all the principles of it to gentlemen and noblemen who almost at all times have had free recourse to my instruments. And if any of these workmen have been so ingenious as to have got my invention, how far you may please to reward them for their piracy must be left for you to determine; and I must set myself down in old age, and thank God I can be more easy in that I have the conquest, and though I have no reward, than if I had come short of the matter and by some delusion had the reward!"

The Right Honorable the Earl of Egmont was in the chair of the Board of Longitude on the day when this letter was read—June 13, 1765. The Commissioners were somewhat startled by the tone which the inventor had taken. Indeed, they were rather angry. But Mr. Harrison, who was in waiting, was called in. After some rather hot speaking, and after a proposal was made to Harrison which he said he would decline to accede to "so long as a drop of English blood remained in his body," he left the room. Matters were at length duly arranged. Another Act of Parliament was passed, appointing the payment of the whole reward of 20,000*l.* to the inventor; one moiety upon discovering the principles of the construction of his chronometers and assigning his four chronometers (one of which was styled a watch) to the use of the public, and the remaining moiety on sufficient proof on the correctness of the chronometers.

Mr. Harrison, accordingly, made over to the Commissioners of Longitude his various timekeepers, and deposited in their hands correct drawings, so that other skilful makers might construct similar chronometers on the same principles. Harrison expressed the greatest readiness to explain his inventions, and to subject them to every required test. Indeed, there was no difficulty in making the chronometers, after the explanations and drawings which Harrison had published. An exact copy of his last watch was made by the ingenious Mr. Kendal, one of Harrison's apprentices. This chronometer was used by Captain Cook during his three years' circumnavigation of the globe, and was found to answer as well as the original. This, as well as Harrison's chronometer, is still to be seen at the Royal Observatory, and both are in good going condition.

Although Harrison did not obtain the remaining moiety of his reward until 1767, two years after the above-mentioned meeting of the Board, his labors were over, his victory was secured, his prize won. Notwithstanding his delicacy of health he lived a few years longer. He died in 1776, at his house in Red Lion Square, in his eighty-third year. It may be said of John Harrison that by the invention of his chronometer he conferred an incalculable benefit on science and navigation, and established his claim to be regarded as one of the greatest benefactors of mankind.

S. SMILES.

The Thermometer.

ALTHOUGH the invention of the actual thermometer, as such, is claimed by many, still the first conception must be awarded to Cornelius Drebbel, of Alkmaar, Netherlands, in the beginning of the 17th century. He took a glass balloon, which had been drawn out to a long tube, heated it, and dipped its open end into a vessel with alcohol. When the glass sides cooled, and the inclosed air cooled in consequence, the fluid mounted in the tube. This experiment of Drebbel dates from the year 1603. His apparatus spread especially to Italy; only arbitrary scales could be given with the device, but no stable points, since none such were known, between which a scale proper might be introduced by proper subgraduations. The Florentine Academy del Cimento finally found one such, and it is probable that to Galileo is due a great part of the discovery. Small balloons, blown to a narrow glass tube, were partly filled with alcohol, after which the hole was closed. The bulb was next inserted into snow or ice, and the point to which the fluid sank was noted. One point was hereby found which might be established with every thermome-

ter, but a second fixed one was still wanting; this was discovered by Halley, in the year 1693, when he observed that mercury, as well as alcohol, always obtained the same height if the apparatus was inserted into boiling water. This made it possible that all the instruments talked the same language, but another forty years passed away until scales were reduced to something like order. Fahrenheit, in Dantzic, employed mercury for filling the tubes, designated the melting point of ice as the 32d degree, and divided this scale from here to the boiling point of water into 180 degrees. His point of zero corresponds to the greatest cold at Dantzic in the winter of 1709. Réaumur, on the other hand, divided his scale between freezing and boiling points into 80 equal parts, Celsius used the decimal division, and introduced the scale named for him. Both England and America retain Fahrenheit, in spite of his imperfections, when compared to the present state of science; France uses Celsius exclusively, while Germany sticks to Réaumur.

For constructing a thermometer, let us commence with the ordinary spirit thermometer, as it is called, where the indications are given by the expansion of a quantity of alcohol, which fills entire a glass bulb, and partially a narrow tube attached to it.

To construct such an instrument, a capillary tube is selected, of as uniform a bore as possible. The easiest method of testing its uniformity is to introduce a column of mercury about an inch long into the tube, and gradually move it along by inclining the tube, carefully measuring the length of the column in each of its successive positions. It is plain that the column will be longer or shorter if unevennesses occur in the bore. Should considerable differences be found, the tube is to be rejected. The best tubes are those which, should they show any variations, taper very slowly, but uniformly, from one end to the other—a defect for which full allowance can be made in the subsequent graduation of the scale. A bulb is blown on one end of the selected tube, large, if the instrument is intended to be delicate, and small if simply for a common one, or that is intended to register a large extent of temperature. The bulb is heated to expand the contained air, and the open end of the tube is plunged into alcohol, usually colored for greater visibility. Accordingly as the bulb cools, the atmospheric pressure on the alcohol in the vessel forces some of it into the bulb. The tube being then inserted, a few dexterous taps suffice to drive the greater part of the alcohol into the bulb. The lamp is again cautiously applied until the alcohol boils, and the rapidly escaping vapor almost entirely expels the air from the tube, the open end of which is at once plunged again into the colored spirit. Unless the stem be nearly forty feet in length, and thermometers have been made by several parties of similar lengths for measuring underground temperature—the alcohol fills the whole bulb and stem as soon as the glass has cooled. The bulb is again cautiously heated so that, by the expansion of the alcohol, such a portion may be expelled that when the whole has again cooled, the level of the liquid in the tube may stand near some point previously determined on, with reference to the particular employment for which the instrument is destined. Finally, the lamp being again applied to the tube, near the upper surface of the liquid, that portion of the spirit is again made to boil, and while the vapor keeps the free end of the tube clear of air, that end is hermetically sealed, and the glassblower's part of the work is done. A somewhat similar, but more difficult process has to be gone through with if other liquids, such as ether, sulphuric acid, mercury, etc., are employed for filling the bulb, each of these liquids having its own special use in certain philosophical inquiries. It only remains that the instrument be graduated, so that some definite information may be given by its indications.

The scale in the older thermometers was arbitrary, and no comparable readings could be taken by means of different instruments. In the finest modern thermometers, also, the scale is usually quite arbitrary, being, in fact, engraved on the tube during the process of calibration above described. But then, by careful observation, certain definite temperatures are measured in terms of this arbitrary

scale, so that the value of a degree and the position of some definite zero point are determined for it, and the result engraved on the tube. These numbers enable us, by an easy calculation, to reduce the observed reading of the fine instrument to its equivalent in some of the standard scales

At present we assume what is very nearly true, for mercury at least, that equal increments of bulk correspond to equal increments of temperature. All that is necessary, therefore, is to fix two definite temperatures, and assign their positions on that scale. Water, being one of the most common bodies in nature, and being everywhere easily obtainable in a state of great purity, is usually employed; and its freezing and boiling points are taken as these definite points. The temperature of freezing water or of melting ice is almost absolutely fixed, for pressure alters it only very slightly. It is otherwise with the boiling point of pure water, for this is considerably raised by increase of pressure; so much so, in fact, that if the barometer be not attended to, an error of several degrees is possible. Hence we must define the particular pressure, usually thirty inches, at which the boiling point is to be determined. The thermometer, constructed so far, is to have its bulb and nearly the whole portion of the stem containing liquid, immersed in pounded ice, from which the melting portion is freely trickling, and when the level of the spirit has become stationary, its position, the freezing point, is marked on the tube. Similarly, the barometer standing at thirty inches, the bulb is enclosed in the stem immediately above the surface of water freely boiling. We thus obtain the boiling point. It only remains that we decide of by what number these points shall be indicated, because, on account the nearly uniform expansion of mercury, then the remaining division can at once be filled in by dividing the interval between them into equal parts, or, if necessary, allowing for a slight taper in the tube. The only scales which require mention are those of Fahrenheit, Réaumur and Celsius. The relations of these scales will be easily understood by means of the following figure:

Fahrenheit	32	77	122	212
Réaumur	0	20	40	80
Centigrade	0	25	50	100

In the Fahrenheit scale the freezing point is 32° , and the boiling point 212° , so that the space between these is divided into $212-32=180$ equal parts or degrees. In the others the freezing point is the zero, but the boiling point is 80° and 100° respectively. It is of course perfectly easy to reduce from one of these scales to another. Thus: What is the Centigrade reading to 77° F.? The numbers in Fahrenheit's scale are all too great by 32, because 32° , and not 0° , stands for the freezing point. Subtract this from 77, and we have 45. Hence the required number of Centigrade degrees must bear the same ratio to the 100 from freezing to boiling in that scale, that the 45 bears to the 180 degrees between the same limits in Fahrenheit's. The requisite number is therefore $\frac{45}{180} \times 100 = 25^{\circ}$ C. In words: To convert Fahrenheit to Centigrade, subtract 32 and multiply by $\frac{5}{9}$, or $\frac{100}{180}$. *Vice versa*, to pass from Centigrade to Fahrenheit, multiply by $\frac{9}{5}$ and add 32. Thus, the Fahrenheit value of 50° C. is $\frac{9}{5} \times 50 + 32 = 122$, as in the figure. Of course, the similar processes with Réaumur's scale presents no difficulty.

It is supposed that Fahrenheit fixed his zero at the point of greatest cold that he had observed, possibly in Iceland, more probably by means of a freezing mixture, such as snow and salt, or sal ammoniac. It is much to be desired that the Centigrade scale alone should be employed.

A mercurial thermometer ceases to be of use for temperatures only a little above the freezing point of mercury; but it has a wide range upward, as mercury does not boil till about 600° C. On the other hand, a spirit thermometer, though of little use beyond about 50° or 60° C., since alcohol boils at 70° C., is useful for any degree of cold yet produced, as alcohol has never yet been frozen. When extreme sensitiveness is required, ether, being considerably more expansive than alcohol, is sometimes employed: as by Thompson in detecting the effect of pressure on the freezing point of water. Water, again,

would be about the very worst substance with which a thermometer could be filled, for, not to speak of its expanding in the act of freezing, and therefore necessarily bursting the instrument if it were ever allowed to reach the freezing point, its scale would read partly backward and partly forward; for as ice-cold water is gradually heated up to 4° C., it contracts, and begins to expand again after that limit has been passed.

To make thermometers self-recording, various schemes have been proposed, of which we shall notice only one or two. Those most commonly used indicate only the maximum and minimum temperature during each twenty-four hours, or during the interval which has elapsed since they were last set. The usual arrangement consists of two thermometers, a mercurial and a spirit one, fixed horizontally to the same frame, with their bulbs at opposite ends of the frame. Above the mercury is a small piece of steel or ivory, and in the spirit a small and light float of glass or enamel. Capillary forces prevent the steel from entering the mercury, and the enamel from leaving the spirit. As the mercury expands, it pushes the steel before it, and when it again contracts, it leaves it behind; the end nearest the mercury thus remaining at the highest or maximum indication which that thermometer has given. In the spirit thermometer the liquid, as it expands, freely passes the enamel and leaves it undisturbed, but it can never contract so as to leave it dry. It therefore pulls the enamel back when it contracts, and thus the extremity furthest from the bulb marks the lowest point which the spirit has reached, or the minimum temperature. To set this instrument, incline it so that the steel falls back to the surface of the mercury—the enamel at the same time comes to the surface of the spirit.

The best mode of registration is undoubtedly the photographic. For this purpose a mercurial thermometer is placed vertically before a narrow slit, in such a way that no light can pass through the slit save above the level of the mercury in the tube. A gas flame is kept burning at some distance in front of the slit, the bulb of the thermometer being protected from its radiation, and behind the slit a sheet of prepared photographic paper is exposed to the narrow line of light which passes above the mercury. The paper is fixed on a cylinder with vertical axis, which is made to revolve uniformly by clockwork. Lines are drawn by the clockwork on the paper, giving the position of the slit each hour of the twenty-four, or the gas flame is mechanically reduced or eclipsed at intervals of an hour; so that the record, when photographically developed, gives the temperature for every minute of the day and night. To find from such a record what the temperature was at any hour, say 5 hours thirty minutes, A. M., draw a vertical dotted line, and from the point where it meets the dark space draw a horizontal line. This intersects the scale at 36° , the temperature required.

Among ordinary meteorological instruments, the wet-bulb thermometer is deserving of notice. It is simply an ordinary thermometer with the bulb covered with paper or cotton wool, kept constantly moist by the action of a few fibers connecting it with a small vessel of water. If the air is saturated with moisture, there will be no evaporation, and the wet-bulb thermometer will give the same indication as the dry-bulb. But the dryer and the warmer the air is, the faster does the water evaporate, and (the latent heat of vaporization being mainly taken from the moist bulb) the lower does the mercury sink in the moist bulb instrument. The difference between the readings of the two instruments, compared with the actual temperature as shown by the dry-bulb, thus leads to a determination of the moist condition of the air.

There are many other very interesting instruments connected with the thermometer, such as the pyrometer, hygrometer, æthroscope, etc., but a debate of them would lead us too far for the present, and we may recur to them at some future time.

Rare Gems.

[From *Art Amateur*.]

THE RAREST and most precious of all nature's works have been chosen by all the world for the adornment of women, and the degree of renunciation of these things on the part of men is in some sort a test of civilization. But, as with other inheritances peculiarly theirs, women have only half entered into this field of decoration.

Diamonds, rubies, sapphires and emeralds they know, but these, though their commercial value is greater, are but a small part of the gems whose beauty and luster add to women new charms. This is to be regretted, for if it is permitted to find fault with the use of precious stones, it is because they are too self-asserting, calling attention to their own beauty when they should only enhance the beauty of others. It is a truth that does not need reiteration that no article of dress should challenge attention from the wearer. The preservation of proper and harmonious relations constitutes the art of good dressing; hence, big diamonds are simply vulgar. The less prominent stones have greater powers of adaptation, and more readily lend their soft beauty to enhance the charms of those who possess them. These stones, moreover, afford some of the choicest opportunities for the exercise of the jeweler's art. In the unique works made of them, diamonds are simply accessories however lavish their use; they are glittering rivets, fringes of light about a soft radiance, or lustrous gleams through the gold net-work in which other gems are set. In this way diamonds are wonderfully effective. Alone they are becoming only to marvelously fair persons, inasmuch as their cold glitter will not blend with ordinary human tints. Few women are proof against the seductions of diamond bracelets, necklaces or tiaras, but it is a form of self-abnegation to wear them. That they are so unbecoming is the reason that now when diamonds serve as principals, they are accompanied by rubies and sapphires and emeralds, equalling them in size and adding warmer and more permanent color to their cold glitter. Scarcely a piece of recent jewelry is made of diamonds alone. One of the fortunate results of this desire for color has been the prominence given to colored diamonds, particularly to the yellow and brown diamonds whose warm tints are in such perfect harmony with the soft olives and browns that are now worn in costumes. The brilliancy of these stones blends also with the warm tones of brunettes, on whom white diamonds shed an ashy tint. Some of these colored stones are magnificent in size and luster, and they are prized by connoisseurs, who value them as they do other unique objects. So well are they adapted to personal adornment that it is to be regretted when fate makes of them merely curiosities.

Most of the new stones are characterized by the prevalence of chrome in their composition. This gives to them that warm hue which is the chief source of their beauty and of their present consideration as a part of the toilet. It is this same yellow tone which gives us the wide range of olives in greens and browns, the ambers, the yellow reds and the crushed strawberry, and with these may be included the turquoise blues, whose greenish tinge distinguishes them from the gray blues, the gendarme blues, and the Mazarin blues of past renown. Such colors need no other justification than the fact that by means of this warm tint they are rendered so generally becoming, particular colors and tones being of course specially suitable for particular individuals. The stones which may be mentioned as embracing the same range of warm colors are the tourmaline, the hyacinth, the peridot, the chrysoberyl, the ruby spinelle, the yellow sapphire, known as Oriental topaz, the light red sapphire, the pink and yellow topaz, the aqua marine, the fire opal and the brown cat's-eye, and to these may be added the colored diamonds, colored pearls, pink coral, pink shell and amber. This furnishes a list which, in range of color and expense, allows to almost every woman some special jewelry adapted to her, and to her particularly.

The tourmaline is among the most prominent of the new stones, and no setting for it is considered too magnificent. It is pink, blue and green, but the last is the more common color. This is a deep olive whose beauty comes out chiefly in combination. A beautiful example is seen in a lace pin, in which a tourmaline is grouped with a ruby spinelle in the center of the pin, whose head is a yellow diamond. The matching of these stones is akin to the painters' art, and their chord of color suggests the costumes which they will adorn, as well as the tawny type of beauty which they will best become.

A glance at them raises a vision of Titian women with golden red and golden brown hair and creamy complexions, with faint red in

the cheeks, dressed in rich green plushes, velvets and brocades, with glimpses of yellow in linings and puffs, and creamy lace fastened at the neck. The tourmaline is always set with other stones, occasionally with diamonds alone, but it is too well adapted to more definite purposes to appear at its best with diamonds, and deserves grouping with other colors.

The peridot is a lighter olive green stone, which, during Pliny's time, was held in great veneration, but until now has not since been highly prized. It enters into the same combinations as the tourmaline, but is lighter and gayer in tint, and suggests thinner materials than the tourmaline, such as lustrous silks, gauzes and silk mulls. Instead of yellow diamonds and the ruby spinelle, the peridot can be grouped with the pink and yellow topaz, with here and there splashes of diamonds in the setting. Such a pin as the one described above may be of peridots and topaz; diamonds, if the cost of them can be afforded, will make it a sumptuous adornment.

The chrysoberyl is the lightest of these gems. It is pale green with a golden gleam, and never more beautiful than with yellow-white muslins, mulls and gauzes, or with yellow-white silks and satins. Its beauty is so delicate that it does not combine readily except with carefully-chosen tints, such as the lightest ruby spinelles, or the yellow tones of pink topaz, although a brown topaz or brown cat's-eye is often used with it with fine effect.

The cat's-eye is in general a stone for men. Certainly all gray cat's-eyes belong to the male sex. There is, however, a brown cat's-eye which makes a most becoming adornment for a lady. The cat's-eye is a Ceylon stone, its perfection being marked by the distinctness of the lines forming the iris. A pin with a chrysoberyl or yellow diamond head and a fine cat's-eye half way down, held as it were by two small yellow diamonds or chrysoberyls, is a pin to wear with the copper brown moirés mingled with satin, which are among the beautiful materials of the day for those ladies who like "symphonic toilets."

Among the even less known stones are the wonderful Alexandrites and the Rutilles. The latter is a North Carolina stone, the nearest approach to a black diamond; it is set with pearls or diamonds and adapted to half mourning. The Alexandrite is a stone which by day is a dark green, showing when carefully observed, certain red gleams which at night leap forth and change the stone from green to red. The Alexandrite is often set alone with diamonds, which do not interfere with its peculiar nature, and is often one of the stones in the rainbow-hued lace pins.

The topazes are among the most useful of the colored stones because of their range of color. A most striking pin for a brunette is made of large light and dark yellow topazes set alternately in filigreed gold. Although the topaz is not so valuable in itself as other stones, the ease with which it may be combined with others makes it a favorite among jewelers. All stones sufficiently hard are now engraved, and the brown topazes are prized for this use. Oblong bars of brown topaz are seen, with a Venus drawn by cupids and with cupids in her train. This design is cut in intaglio with exquisite grace, and made resplendent with fringes of diamonds. Such gems are true works of art, and lose nothing in becomingness as articles of adornment. For elderly ladies, or for those who wear amber-hued silks, nothing could be more suitable than these topaz bars. The pink topaz is also engraved in bars and medallions. For a young girl there is a medallion of rose pink topaz on which is the head of Marie Stuart in wide ruff and pearl-edged coiffure, with a fringe of small diamonds.

In engraved work nothing exceeds in delicate beauty the ornaments in aqua marine, which are covered with illustrated legends in exquisite intaglio. These furnish the most beautiful ornaments now produced for pure blondes, by reason of their pale sea-green tints. Large medallions of aqua marine have ideal heads, or the magnificence of Marie de Medici set with colored diamonds like a glory about it. An oblong bar displays a Greek procession set around with small diamonds; from this depends a cross of aqua marine cut in intaglio with diamonds in trefoil at the ends and in the corners.

The opal is one of the stones that yields gracefully to the engraver. It is cut in relief resting on the brown matrix which in many instances makes an appropriate background. The wonderful colors which seem to have been borrowed from every gem are finely brought out by the carving. Opal medallions, for they are seen chiefly in this shape, belong to blondes, the colors being too pure and delicate for other types. Cut "en cabochon" fire opals, whose tints are warmer, are worn to advantage with darker complexions, particularly if they are warm-toned. For the paler blondes there are blue sapphires and emeralds, and for these and the colorless brunettes there are rubies whose red inclines to purple rather than yellow. There must be mentioned also a pale sapphire found in Montana for cool blondes and pale olive brunettes. Yellow and brown pearls are likewise in great repute and take a good place among colored stones. Pink coral, if yellow-toned, belongs to warm blondes and the possessors of reddish-brown hair. M. G. H.

A Fire and Burglar Proof Building.

A CORRESPONDENT of a German paper says that the season of burglaries has this year commenced earlier than usual in London, and already in the month of October several bold robberies have been committed. There is one locality in London, however, on which probably all the thieves in the world would practice their cracksmen's art in vain, although the booty to be obtained would be worth the trouble. We refer to the National Safe Deposit Company, which the writer of this had the pleasure of inspecting a few days ago. The flooring consists of a layer of brick and concrete (beton) twenty feet thick, lying upon solid earth more than forty feet thick; upon this stands within a strong wall a basin containing eight feet of water, so that anyone who might try to enter the vault by a subterranean passage from below, would at once be drowned. Above this basin is the flooring of the actual building, consisting of a layer of brick and cement, two and one-half feet thick, over which lies a steel plate four and one-half inches thick. Upon this stands the safe-building, the side walls and ceiling of which is formed of a layer of four and one-half inch steel plates, a second layer, twelve inches thick, of beton, and two layers of heavy iron plates, which again are surrounded by a strong wall of fire-proof brick. The entrance is not closed by doors turning upon hinges and locked, and which therefore might be burst with dynamite, but with a twelve-inch steel plate, raised every evening with hydraulic pressure, and is immovable until again let down by the press. The building is surrounded by a second high wall, four feet thick, of brick and beton, while the open space between the wall and building is patrolled night and day by armed watchmen. The building thus appears to be burglar proof as well as a fire, water and bomb proof. The vault contains at present 5,400 safes, belonging to bankers, jewelers and business men of the city. The building, the floor of which measures 7,000 square feet, has capacity to contain 20,000 safes.

Sixth Annual Meeting of the Jewelers' League.

THE SIXTH annual meeting of the League was held at Association Hall on the evening of January 16th, the President, Gilbert T. Woglom, occupying the chair. The minutes of the previous meeting as printed were approved.

The President then submitted his annual report, wherein he reviewed the work of the past year, and made many valuable suggestions relative to what should be done in the future. It was an able presentation of the whole subject of trade benefit societies, showing their importance, and also the necessity of careful and judicious administration of their affairs. The address showed much research and careful study of the subject, and is a document that should be carefully read by every member of the League. We regret that it comes at so late a period of the month that we are unable to present it entire, but as it will be printed and circulated in pamphlet form, it will be readily obtained by all interested in the League.

The reading of it was listened to with marked attention, and at its conclusion the author was greeted with much applause.

The examining Finance Committee reported having examined the accounts of the Secretary and Treasurer and found them correct.

The Treasurer and Secretary submitted his report as follows, which was adopted:

Membership of League, January 17th, 1882		1,654
Applications received during year 1882.....	787	
Applications rejected " "	23	
Applications referred for investigation, (not yet accepted)....	19	42
Members accepted during the year.....		745
Members dropped for non-payment of assessments.....	44	
Members resigned.....	1	45
Increase for year.....		700
Members died during year.....	10	
Net increase during the year.....		690
Total Membership at date.....		2,344
Members died since organization, June, 1877.....	19	
Members resigned " " June, 1877.....	1	
Members dropped " " June, 1877.....	49	
Members expelled " " June, 1877.....	1	70
Total Membership number.....		2,414

	GENERAL FUND.	BENEFIT FUND.
Balance on hand January 17th, 1882.....	\$2,639 07	\$3,142 60
RECEIPTS.		
745 Members' Initiation Fees, at \$3.00.....	2,235 00	
745 Members' First Assessments, at \$2.00.....		1,490 00
Amount from Reinstatements.....	118 00	
Interest on Deposits at Union Trust Company.....	94 59	
Coupons from Government Bond.....	2 00	
Assessments Numbers 10 and 11.....		6,712 00
" " 12 and 13.....		6,656 00
" " 14 and 15.....		7,608 00
" " 16 and 17.....		7,810 00
" " 18 and 19.....		8,640 00
Total Amount to Credit of Treasury.....	\$5,088 66	\$42,058 60

DISBURSEMENTS.		
Beneficiary of J. H. Willemin.....	\$3,142 60	
" E. C. Taylor.....	3,117 90	
" Jos. Treulich.....	3,258 50	
" George A. Cory.....	3,231 90	
" James A. Bogart.....	3,568 20	
" Ganson B. Holton.....	3,680 30	
" Hiram Sweet.....	3,680 30	
" Wm. N. Evans.....	3,805 70	
" F. Theo. Forsberg.....	3,980 50	
" Dyer Brainerd.....	4,193 30	
Commissions of Secretary and Treasurer.....	1,945 80	\$37,605 00

Balance in Benefit Fund..... \$4,453 60

MISCELLANEOUS.		
Books, Stationery and Printing.....	\$ 689 09	
Postage.....	260 98	
Rent of Post Office Box 3,444.....	16 00	
Insurance Department of New York State.....	18 00	
Union of Mutual Benefit Associations.....	35 00	
Services of Attorneys and Actuary ..	271 30	
Printing for "Committee of Eighteen,".....	33 00	
Furnishing Office.....	475 19	
Wood, Coal and Gas	9 88	
Mercantile Safe Deposit Company.....	2 00	
Rent of Office to January 1st, 1883.....	125 00	
Stenographer for Annual Meeting, 1883.....	15 00	
Hire of Hall for " " "	11 50	
Commission of Secretary and Treasurer.....	117 65	2,079 59

Balance in General Fund..... \$3,009 07

Total Balance in Treasury..... \$7,462 67

\$50 Government Bond held in trust for Executive Committee.

WM. L. SEXTON,
Secretary and Treasurer.

The report of the Committee of Eighteen on amendments and revision was submitted, a synopsis of which has heretofore been printed in THE CIRCULAR. The following is the substance of the recommendations made by the Committee.

1st. That the proposed amendment to the Constitution "to reduce the limit of age of new members to forty years," be not adopted.

2d. That the proposed amendment to the Constitution making no limit to the number of membership in the League, be approved; provided, that at no time shall more than \$5,000 be paid as a death benefit.

3d. In the interest of members of the trade who desire to join the League, but who do not desire as much as \$5,000 benefit, and for those who are members now and who would prefer a smaller amount of benefit, it is recommended that a new section shall be formed in the League, with a death benefit, when full, of not to exceed \$1,000, the entrance fee to be the same as at present, namely, \$3.00; this new section to be termed Section B, and the section composed of the present membership, be termed Section A.

4th. That the limit of age at entrance for members of Section B shall be from 21 to 55 years, and the number of members shall be unlimited; provided, that not more than \$1,000 be paid as a death benefit.

5th. That death assessments in Section B shall be graded according to age, the amounts to increase each year, as per table accompanying this report.

6th. That "reserve funds" for both of the sections shall be accumulated in the manner recommended herein.

7th. That the reserve funds of the two sections shall be drawn upon to pay death losses, whenever, in any one year, the death rate shall exceed 1-4 per cent. of the membership in the respective sections, and at the same time, one-fourth larger than could reasonably be expected, from the experience of the two years previous.

8th. That the reserve fund of Section A shall not be allowed to exceed \$100,000; and that of Section B not to exceed \$20,000.

9th. That the money for the reserve funds shall be invested only in U. S. Registered Government Bonds, or New York State, New York City, or New York County Bonds, and shall be in the custody of a Board of Six Trustees, who shall be elected annually. At the first election, two to be elected for one year, two for two years, and two for three years. Thereafter, two to be elected annually for three years.

10th. That change of business subsequent to becoming members of the League shall not operate to impair membership in either section, or make them ineligible to any section or sections.

11th. That the initiation fee for both sections shall constitute a general fund, out of which the expenses of conducting the business of the League shall be paid.

12th. That if at any time the Executive Committee should, by a unanimous vote, recommend the transfer of any portion of the general fund to the reserve fund, it shall be divided between both sections, in proportion to the amount paid into the general fund by each section; but when once placed in said reserve fund, it shall be used for the purposes of such fund, and shall not be returned to the general fund.

13th. That the present or any other donated fund, by the consent of the donors, shall be transferred into the permanent fund of Section A, provided these recommendations shall be adopted.

14th. That the League shall adopt a badge representing the Seal of the League.

15th. That in Section 3, Article 6, of the Constitution, the words "exclusive of the special deposit provided for in Section 1, of this article," be inserted after the words "accrue in any manner."

S. H. Hale, a member of the committee, desired to submit a minority report, but was ruled out of order. He appealed from the decision of the chair, but the chair was sustained by vote of the League.

The report of the Executive Committee was then read as follows and adopted:

Mr. President and Gentlemen:

Your Executive Committee in presenting this, their sixth annual report, congratulate you on your prosperity and the sound and substantial basis that you have attained. Our membership to-day numbers 2,344.

During the year, your committee has held fifteen meetings (regular and special,) at which a large amount of business has been dispatched.

During the past year death has removed from amongst us ten of our number. These death claims have been critically examined, and no defects having been found, their beneficiaries were promptly paid the proper amounts.

There have been presented to us for our consideration during the past year, 787 applications for membership, of which number 745 were accepted, 23 rejected, and 19 referred for correction, etc., which are now in the hands of the Secretary.

To show the relative growth of the League, we have taken the membership of each year as presented to you in former reports:

May, 1877, to January, 1878,	-	-	-	132
January, 1878, to January, 1879,	-	-	-	297
" 1879, " " 1880,	-	-	-	563
" 1880, " " 1881,	-	-	-	1059
" 1881, " " 1882,	-	-	-	1669
" 1882, " " 1883,	-	-	-	2414

Out of this number we have lost by death,	-	-	-	19
By resignation,	-	-	-	1
Dropped from the membership for non-payment of assessments,	-	-	-	49
Expelled,	-	-	-	1
Total since organization,	-	-	-	70

The amount paid to Beneficiaries of deceased members up to January, 1882, was,	-	-	-	\$18,138.40
And for the ten Benefits paid during the past year,	-	-	-	35,639.20

Total amount paid to the Beneficiaries of deceased members since organization,	-	-	-	\$53,777.60
--	---	---	---	-------------

We make the almost phenomenal statement that, notwithstanding our League and its members growing older year by year, the accession of young members has caused our average age to decrease yearly, since 1880, as follows:

Average age of the membership, January 1, 1879,	-	35.50
" " " " " 1880,	-	37.95
" " " " " 1881,	-	36.98
" " " " " 1882,	-	35.78
" " " " " 1883,	-	35.67

As the membership of the League has become so large, and in the future grave questions may arise which will require the combined counsel of a larger body of your members, your Committee recommend that an amendment to the Constitution be passed, making the Vice-Presidents *ex-officio* members of the Executive Committee.

The League has been well and honorably represented in the Union of Mutual Benefit Association by its worthy President, Mr. Woglom, who is also an officer in that association, and by Mr. R. A. Johnson, of your Committee.

The business of the League becoming so large and cumbersome, your Committee deemed it best to secure an office where the meetings could be held and its records and books kept. They secured a room at nominal rent, at 61 Nassau street, where all our members are cordially welcome.

In case of any change in the relations and states of their Beneficiaries, members should give immediate legal notice of change of Beneficiary, and thus save innumerable chances of litigation.

Your Committee would like to impress upon the members the necessity of notifying the Secretary of any change of address.

Your Committee have selected with great care, a list of surgeons in the larger cities, as Medical Examiners, feeling that our interests would be conserved by surgeons of our own appointing.

The Committee of Eighteen appointed at the last annual meeting made their report, and as instructed, a copy was forwarded to each member.

Furnishing an office, legal advice in regard to payment of certain death claims, and of the Committee of Eighteen for advice from an actuary, printing, etc., make the expenses apparently excessive, but they have been kept as low as practicable, consistent with the proper transactions of business.

Your Committee feel that the success of the League is largely due to the efforts of individual members, in soliciting their friends in the trade to join their association, and to the trade journals for their warm and friendly support of our cause; and also to Dr. Wilbur, the League Surgeon, for his care in examining all of the applications which have come before us.

During the past two years Jos. R. Richards has proposed forty-five members; H. S. Cozzens and Geo. A. Tuthill each thirty; Geo. W. Shiebler and Caleb Clapp, each seventeen; T. W. Manchester, A. A. Jeannot, Geo. W. Reynolds, Jr., and A. Kurtzeborn, each sixteen; W. B. Kerr, F. D. Steck, Henry Hayes and W. F. Cory, each fifteen; B. H. Knapp, Geo. H. Richards, Jr., H. C. Bucklin and H. A. Barmeir, each thirteen; S. A. Baldwin, S. E. Fisher, D. H. Hopkinson, A. Hirsch and W. G. Blair, each twelve; Henry E. Ide, W. J. Erve and Jacob Marx, each eleven.

Fourteen other members have proposed ten members each; eight have proposed nine each; eight others have proposed eight each; thirteen members have proposed seven each; twelve members have proposed six each; thirty-three members have proposed five each.

J. R. Richards, since the organization of the League, has proposed over 100 members; H. S. Cozzens over sixty; Caleb Clapp over fifty; Geo. A. Tuthill, Geo. W. Shiebler, T. W. Manchester, A. Kurtzeborn, W. B. Kerr, W. F. Cory, F. D. Steck and D. H. Hopkinson, over thirty.

In conclusion, fellow members, we feel that our hopes of six years ago have been realized, that we have assisted in establishing and building up an association which stands to-day in the front ranks of all similar institutions in the country. Let us, then, one and all, join in promoting the interests of our association, recommend it to our brethren in the trade, and thereby do them a kindness and advance our own best interests.

Respectfully submitted,
 ROBERT A. JOHNSON, JOHN D. LYON, J. D. YERRINGTON,
 GEO. W. SHIEBLER, J. B. BOWDEN, W. C. KIMBALL, *Chairman*.
 January 16th, 1883.

Several communications on various topics were read and ordered filed. Among them was a lengthy document from Mr. Hayes, proposing several amendments to the Constitution and By-Laws, which will also appear in pamphlet form.

Mr. Lyon offered an amendment to the Constitution making the Vice-Presidents *ex-officio* members of the Executive Committee. Unanimous consent having been obtained, the amendment was adopted.

Mr. Hale submitted the following communication, which was ordered filed.

To the Members of the Jewelers' League:

I beg leave to submit the following communication :

First.—That the maximum age be *reduced* to 40 years.

Second.—That the membership of the League be made unlimited.

Third.—That all surplus funds which may accumulate in the Treasury from any source in excess of the two thousand dollars now provided for, shall be placed in a Permanent Fund, and shall remain as a Permanent Fund until such time as the death rates shall exceed the number of twenty in one year, after which all death losses in excess of twenty shall be paid out of the Permanent Fund in lieu of an assessment or assessments.

Fourth.—That at no time shall the amount in the Permanent Fund exceed the sum of one hundred thousand dollars, and that when such limit is reached, all excess of this sum shall remain in the Death Loss Fund and be used as now provided for—or as may be provided for in suitable amendments to the Constitution.

Proposed Amendments to the Constitution, to carry into effect these recommendations, have been filed with the Executive Committee.

It is believed that if these Amendments are adopted, that the needs of the League will be fully cared for, its present simple and effective methods retained, and its permanency assured.

Most respectfully submitted

S. H. HALE.

The report of the Committee was then taken up *seriatim* and acted upon. The first recommendation was rejected; the second recommendation was adopted; the third was rejected; the fourth and fifth were laid on the table; the sixth was rejected.

Mr. George C. White, Jr., spoke at length on recommendation No. 7, in favor of a reserve fund, after which the recommendation was laid on the table.

The eighth, ninth, tenth, eleventh, twelfth and thirteenth recommendations were then discussed and laid on the table; the fourteenth was accepted, as was also the fifteenth.

The amendment to the Constitution submitted by Mr. Hale, limiting membership to those between the ages of twenty-one and forty, was voted upon and declared lost.

It was voted to amend Section 1 of Article 2 of the Constitution, to read as follows: "Section 1. The membership of the League shall be without limit, provided that at no time shall more than \$5,000 be paid as a death loss."

The election of officers was the next business in order. Ballots being taken, the following-named gentlemen were declared elected to the offices named: Gilbert T. Woglom, President; Wm. C. Kimball, Third Vice-President; August Kurtzeborn, Fourth Vice-President; Wm. L. Sexton, Secretary and Treasurer. The several officers being called upon for speeches, returned thanks for the honor conferred upon them in brief and appropriate remarks. Robert A. Johnson, Samuel W. Saxton and C. B. Bishop were then elected members of the Executive Committee.

The following-named gentlemen were then appointed as Examining Finance Committee: Charles G. Lewis, C. G. Alford and George R. Howe.

On motion the meeting then adjourned.

The Executive Committee held a regular meeting on Friday, January 5th, 1883, at which the following candidates were admitted:

Max Arnstein, Sigmund Arnstein, Rudolph A. Breidenbach, Geo. S. Bugbee, Thos. H. Dobinson, Edward B. Foley, Henry W. Hiller, Geo. W. Hunt, Ephraim S. Johnson, Florence Krober, Michael Mark, George Nockin, Joseph Raphael, Louis F. C. Schmidt, Wm.

W. Trotter, William A. Wightman, New York City; Fred. A. Hubbard, Brattleboro, Vt.; Herbert L. Draper, Attleboro Falls, Mass.; Lewis K. Katon, Edmund D. Rhodes, North Attleboro, Mass.; Daniel H. Robinson, South Attleboro, Mass.; Willard H. Bennett, Plainville, Mass.; William C. Godfrey, Taunton, Mass.; Alex. M. Harrison, Plymouth, Mass.; Chas. H. Hosley, Springfield, Mass.; Geo. W. Wetherbee, Walpole, Mass.; Frank F. Dodge, Woburn, Mass.; Edward C. Glines, Lauritz G. Höst, Frank Stapleton, Providence, R. I.; Smith C. Blackman, Bridgeport, Conn.; Seth W. Babbitt, Meriden, Conn.; William J. Savoye, Walter G. Savoye, Chas. H. Davis, Geo. Fey, John N. Powell, Harry P. Ridley, Albert W. Southard, Brooklyn, N. Y.; Geo. L. Dillingham, Ogdensburg, N. Y.; Lafayette Hannas, Utica, N. Y.; Albert B. King, Buffalo, N. Y.; J. Winfield Pierce, Syracuse, N. Y.; Fred. H. Bassett, Blue Mountain Lake, N. Y.; William C. Fink, Elizabeth, N. J.; Adolph Yauchler, Gust. A. F. Schuman, Newark, N. J.; Francis J. Quinn, Allentown, Penn.; Geo. W. Ludwig, Chambersburg, Penn.; Samuel Kind, Walter C. McIntyre, Philadelphia, Penn.; Geo. W. Clous, Reading, Penn.; George M. Bailey, Uniontown, Penn.; Robert F. Polack, York, Penn.; John F. Stunz, Fernando Volkmar, Baltimore, Md.; John A. Atwater, Augusta, Ga.; Richard A. Watts, Goldsboro, N. C.; Chas. A. Sanders, Chas. W. Harman, Cincinnati, Ohio; Frederick C. Jost, Cleveland, Ohio; William A. Johnston, Columbus, Ohio; William G. Spies, Steubenville, Ohio; William A. Landt, Leopold Mauch, Nathan Fantl, Chicago, Ill.; Wm. Mauch, Springfield, Ill.; Robt. J. Happy, Clinton, Ill.; Fitch W. Swan, Muscatine, Iowa; Geo. A. Smith, Sac City, Iowa; Frank A. Marshall, East Saginaw, Mich.; Irving Hauser, Leadville, Col.; Philip Potter, Nebraska City, Neb.; William G. Bailey, Helena, Montana Ter.; Clayton F. Lischo, Sioux Falls, Dakota Ter.; Philip W. Ellis, Matthew C. Ellis, Harry Ellis, Toronto, Can. A total of 78 accepted.

The bond of the Secretary and Treasurer was directed to be increased to \$10,000.

A special meeting, and the last for the year, was held on January 11th, at which the following were accepted:

Carl W. Grosche, Charles F. Ketcham, Alfred J. Parker, Stephen S. Potter, Adolph H. Storz, John N. Taylor, Emil Wolf, New York City; Henry N. Lockwood, George B. Tobey, Boston, Mass.; Geo. H. Woods, Springfield, Mass.; Frederick W. Bauer, Piermont, N. Y.; Henry E. Cornwell, Hempstead, N. Y.; James R. Montague, Waterloo, N. Y.; Daniel C. Sharp, Chas. E. Dakin, Philadelphia, Penn.; Meyer Kling, Andrew L. Williams, Chicago, Ill.; Harmon H. Kayton, St. Louis, Mo.; Geo. W. Hauenstein, Red Wing, Minn. Nineteen accepted, being a total for the two meetings of ninety-seven accepted, nineteen tabled for investigation, three rejected, and nine changes of beneficiaries granted, and the Committee adjourned *sine die*.

AN ASTRONOMER noticed that the steel parts of a very valuable clock were coated with rust, in spite of a most careful previous cleaning. Since no other instrument in the observatory exhibited a similar appearance, the cause was assigned to the case, and this submitted to a thorough examination. The front part of the case consisted of mahogany and the back part of oak wood, while both were connected by copper braces. It was suspected that the oak wood exerted the injurious influence, wherefore the copper braces were unscrewed, and it was found that those parts passing through the mahogany were entirely lustrous, while the ends through the oak wood were covered with copper oxide. Small holes were bored into the wood, the chips, amounting to a small fraction of a gram, were heated in boiling water above a flame and litmus paper was dipped into it, which was at once reddened. Perfectly dry pieces, stuffed for a few seconds into the holes, were strongly reddened after a few seconds. From this may be seen that the acid contained in oak wood is extremely volatile, and this wood is not whatever suitable for instrument casings.

Honors to an Australian Representative.

ON THE 6th of January Messrs. Robbins & Appleton tendered a dinner to Donald Manson, their Australian representative, at the rooms of the Union League Club. Sumptuous as were these rooms, the table was equally ornamented by elaborate dishes, composing a most tempting *menu*, to which the assembled guests did ample justice.

When the work of destruction was completed, Mr. Appleton, who presided, arose and addressed Mr. Manson, speaking eulogistically of the valuable services rendered to the American Watch Co. by that gentleman, and holding him up as an example to all for his devotion and loyalty to the cause of the American watch industry. He proposed the health of Mr. Manson, and asked all to join him in wishing the guest of the evening a pleasant voyage out and success in all his undertakings. Amid great applause Mr. Manson arose to thank the chairman for his expressions of kindly feeling and for the good wishes of all present, referring to the prejudice and opposition American watches had to encounter, especially in countries antagonistic to American enterprise. He said that the excellence of the watches made at Waltham was sufficiently eloquent to brush away every obstacle that beset their introduction into foreign lands, and on this characteristic element of Waltham watches he alone relied for public appreciation in the Australian market.

Congratulatory despatches were sent to Boston, where the foremen and officers of the Waltham Factory happened to be celebrating the completion of the 2,000,000th watch at a dinner at Young's Hotel, the day having been chosen to celebrate also Mr. R. E. Robbins' twenty-fifth anniversary of his assuming the office of Treasurer of the company. Telegrams were sent congratulating him upon the success he has achieved as the pioneer who made the American Watch Company the standard bearer of a new industry in America, an enterprise which, at the outset, employed only a small number of hands, but now affording a comfortable livelihood to more than two thousand men and women in Waltham alone. Many reminiscences of the early days of American watches were told, and thus pleasantly the evening was spent, until at a late hour the party separated under the merry notes of:

"For he is a jolly good fellow,
The which nobody can deny!"

Watch Repairing.

BY HERMAN SIEVERT.

I.

A SIMPLE cleaning suffices only for watches in thorough order. Every new watch, and most of those that have been worn, must be overhauled. This inspection of new watches is called adjustment, and repairs, with old ones. Both are actually the same, because the same labors occur in both instances. We will commence with the parts in regular order, and mention the several corrections. We commence with the *center wheel*. Its pivots, on account of the center staff passing through the pinion, as well as the large power operating upon it, are pretty thick. It is necessary that the hole for the center staff pass exactly through the center of the center pinion, or, what is the same, that both pivots of the pinion run round upon a turning arbor passed through the hole. If this should not be the case, both the hands would not move in the plane of the dial plate, but would alternately stand higher or lower. This defect can quickly be recognized by the walls of the counter-wheel pivots. If this wall is equally thick on all sides, every thing is in order; if not, the untrue pivot must be turned, either upon a turning arbor or directly between the wall centers. The latter is most decidedly to be preferred, because the thin turning arbors are frequently out of round, and beside break easily.* But if the pivots are to be turned

directly between the turning lathe centers, the pivot ends must not be oblique, a condition in which they are frequently found. Wherefore correct first the untrue fore-faces with a sharp graver, but not more than necessary, because the pivots must remain sufficiently long. Next refasten the pinion which has become loose by turning off between the centers, and carefully correct the pivots by turning. This work must be executed in so exact a manner that a few strokes of the pivot-polishing file suffice to polish the pivot perfectly. This is also done with the aid of a turning arbor in suitable pivot-bearings of the turning lathe, similar as by the pivots of clocks. Others also grind and polish the center wheel pivots, by means of a composition file and oilstone powder and rouge or diamantine; still others use the polishing contrivance in the depthing circle with bells or discs for this purpose. Of course, it is immaterial what process be employed, as long as the pivots are made correct; the latter method, however, is the one with which the most satisfactory results are obtained, and furnishes truly round and handsomely polished pivots. But they must in no case be made club form; on the contrary, they should be somewhat tapered. The two center wheel pivots are easily exposed to friction, and care must therefore be paid to provide means for retaining the oil in the holes, so that it cannot run into the pinion, for which purpose the pivot shoulders are separated from it by a groove turned as deep as possible. The pivots must also pass through far enough to prevent the dust plate and canon pinion from entering into connection with the pivot hole and attracting the oil. But for this purpose the holes must not be too narrow; a pivot exactly filling the hole leaves no room for oil, and since an oil sink can but seldom be introduced, a friction due to an absence of oil will soon take place. An excess of oil at these pivots, beyond the capacity of the holes, on the other hand only favors its running into the pinion, or to the dust plate and canon pinion.

Very good and suitable metals for bushing the holes, and with which it does not easily produce friction, are good, white German silver and aluminum bronze. I have used especially the former with excellent success for bushing center wheel holes. As a matter of course, bad German silver turns black, and for this purpose is just as unsuitable as ordinary brass. I remarked already on a former occasion, that it is profitable to prepare the material in flat strips with holes beforehand, in order to have it ready in case of need. Then open a hole until the corresponding pivot fits into it, and separate the piece with a saw. Next turn the bushing upon a good turning arbor, make it right thin, and only little tapering, almost cylindrical, and flat at both ends. The bushing must be only a little longer than the hole to be filled. This is always opened from the inside, that is, from the side from which the pivot enters, so far that the bushing may be pressed in. Next countersink the hole a little from the outside with a very pointed chamferer, a broken broach ground three-cornered and pointed, place it upon a suitable small anvil, and beat the bushing into it with a flat punch. If the opening on the outer side has not been made too large, then the bushing will spread sufficiently from the operation of beating upon the anvil that it fills the countersinking, and is secured thereby. Of course, it must not be fastened in obliquely, because in such a case by the unequal thickness of the walls of the bushing the hole would be pressed to one side. This accident increases with the thickness and undue length of the bushing. The hole will now have become too small by the crowding together of the bushing; if this should loosen, when opened with a sharp chamferer, notwithstanding that it was hammered in tight, it was evident that the walls were made too thin.

Great attention is to be paid to holding the chamferer vertical to the plate, when opening the hole, and for this purpose it is frequently to be inspected from every side. The pivot must not alone run free in the hole, but also have a little visible side shake, too much would be imperious to the depthings.

Above all things, the wheel must stand straight, on account of the contracted space and the free running of the hands. It may be

*The repairer who does not like to turn between wall centers or tapers, may manufacture for his use special turning arbors without rollers, which are not longer than is necessary. They are previously to be hardened, and then annealed only sufficiently (red or dark blue), to permit their being turned off.

taken as a general rule, with watches, that the motion centers of the wheels in the lower plate are not to be changed without special cause; and the lower center wheel hole remains in its place under all circumstances. If necessary, therefore, this is bushed first. Should it protrude, without obvious reasons, turn it down level with the plate. Also remove, by turning, any other unevenness around the hole rim, even if it has not been bushed, since we have seen above that they are apt to mislead in centering. Next screw the center bridge firm upon the plate, fasten this in a careful manner into the turning lathe, as has been described above, and open the hole in the bridge somewhat with the graver. If it is next bushed in a correct manner, then the wheel must stand straight; but the smallest error, owing to the shortness of the arbor, becomes a matter of importance.

When compelled to use a defective turning lathe, it is advisable to first bush both the holes, and to leave them somewhat smaller. The hole in the plate is then first turned a little, next, without removing it, the bridge is screwed on, and also its hole enlarged somewhat by turning. Not to make a misfit, these holes must not be turned out too much, since they have to be opened a trifle afterward.

The untighting of the cannon pinion is a dubious piece of work without a universal lathe, and is more or less tantamount to trying. A removal of the bridge is not permitted. Perhaps the best method is to open both holes at once with a good cylindrical broach, and to inspect the double caliber, by a passing through a turning arbor, whether the plate runs true. Should it be necessary, it is to be widened somewhat, and the broach held over to the corresponding side. If the plate runs true upon the turning arbor, and both holes are then well bushed, the wheel will stand straight.

If the wheel has no end shake, turn off a little upon the universal lathe; but it must be ascertained whether this is best done toward or above or below. Attention must be paid hereby to the length of the pivot holes, the room between barrel and center wheel, and finally the position to the center wheel pinion, so that the wheel does not stand too high to it.

Concerning the universal lathe, I would remark that the placing and screwing of the clamps is not injurious to the gilding; only they must not rub upon it, for instance, if the corresponding piece is moved between the tightened clamps.

(To be continued.)

Obituary.

JOHN T. MAURAN.

The recent death of John T. Mauran, of Providence, makes another gap in the ranks of well-known manufacturing jewelers. He was born in Barrington, R. I., in 1826, and received a liberal education at the academy at Warren. On completing his studies, he in 1849 went to California, but soon after returned and located at Providence, where he engaged in the business of manufacturing jewelry. He was associated with different well-known houses, but finally established a business of his own which he has carried on for many years. In his regular business he met with large success, and in great commercial crises which from time to time visited the country, his credit was without dispute and his paper always honored. For some time he was a Director in the Northern Bank and in the Atlantic Insurance Company. Years of almost incessant application to business were followed by results such as are becoming more alarmingly common than ever in our active, nerve-exhausting American life, and gradually he yielded to the pressure of disease, until he was forced to lay aside all attention to business. Slowly his health failed, until finally death relieved him from his earthly sufferings.

JOHN M. BONNET, SR.

John Mathias Bonnet, Sr., of Zanesville, O., died in that city Dec. 28, in the seventy-second year of his age. He was a prominent and

respected citizen of Zanesville, and his death was widely mourned by his townsmen. Mr. Bonnet was born in Oelbron, Wurtemberg, Germany, in 1811, but at the age of twenty-three he came to this country in company with a young friend. They started at once for the west, and on reaching Zanesville, found they had exhausted their money, so with bold hearts set to work at whatever offered to earn a living. Mr. Bonnet soon found an opportunity to learn the watch making trade, at which he became proficient. He soon engaged in business for himself. He prospered as the country developed, and during a long mercantile career his course was marked by strict business integrity. Six children survive him, one daughter and five sons. Four of these are in business in Zanesville, and one, Jacob N. Bonnet, is a member of the firm of Mulford & Bonnet, manufacturing jewelers of this city.

JOHN CARROW.

John Carrow, long identified with the jewelry trade, died at his residence in Philadelphia, January 19th, in the seventy-third year of his age. The deceased had for many years suffered from a distressing malady, and gradually health yielded to its pressure. Mr. Carrow commenced business in Philadelphia in 1831, when the house of Carrow, Dubosq & Co. was established, which subsequently changed to Carrow, Thebault & Co., then to Carrow, Crothers & Co., of which the present firm of Carrow, Bishop & Co. are the successors. In 1876 he retired from active business. In 1872 he identified himself with the silver-plating business in Philadelphia, which has been continued in his name to date. Mr. Carrow held many positions of prominence and trust, being for twenty-five years a director of the Fire Association, and of the Tradesmen's National Bank of Philadelphia.

J. T. GOLD.

J. T. Gold, one of the most accomplished workmen in this city, died at his home in Northern New York a few days since, of pneumonia. Mr. Gold succeeded his father in the business of manufacturing watch dials, and became well known to the trade for the excellence of his work and the promptness with which he performed it.

Analysis of Metals.

[By H. BUSH, IN *Hull*.]

THE SEPARATION of the different metals, which are often found united in the earth, bases upon the relation or inclination existing between certain metals and other substances. Since these proportions are perfectly known to the chemist, it is easy to effect an analysis of such an alloy.

Let us suppose, for instance, such a mixture contains platinum, gold, bismuth, silver, lead, iron and copper, and we treat it as follows:

1. The alloy is first divided into small pieces, either by granulating or any other manner, they are then emptied into a glass flask and poured over with nitric acid, somewhat diluted, placed upon a heated sand bath, and left upon it until the acid ceases to effervesce. The acid is then decanted from the residue, which is covered with fresh, and this process is repeated until a fresh portion has no further action upon the residue. This now consists of gold and platinum, all the other metals having passed into solution.

2. Cold water is poured to the obtained solution, by which the therein contained bismuth is precipitated, and this is continued until no further turbidity occurs. The solution is poured off and the precipitate dried; 123 parts of the dried precipitate give 100 parts metallic bismuth; melting is effected by stirring the precipitate into a paste with oil, it is then placed into a clean crucible covered with a layer of charcoal powder, and placed into the fire. When melted, it is stirred with an iron rod, and poured into an iron ingot.

3. The solution is next evaporated to one-half its quantity, and a

clean plate of copper is dipped in, whereby the silver contained in the solution is precipitated; the plate is removed, the adhering silver washed off in water, and the operation repeated until no further precipitation takes place. The deposit is then dried and melted, by adding a little soda carbonate.

4. For effecting the separating of the lead, a little sulphuric acid is poured into the solution until no further precipitation is obtained; 100 parts of this dried deposit contain 30 parts metallic lead.

5. Spirits of hartshorn is next added to the solution, whereby the iron contained therein is thrown down as a brown powder, this is washed, well dried, and glow-heated.

6. A saturated potash solution is then added to the solution and boiled for some time, whereby the hartshorn evaporates and the copper contained in it is thrown down. This precipitate is dissolved in sulphuric or muriatic acid, and a clean plate of iron is dipped in, whereby the copper is obtained metallically pure.

7. All the metals contained in the solutions have now been obtained, and we then take in hand the residue of the first process; this is completely dissolved in nitro-muriatic acid, (three parts muriatic and one part nitric acid). The solution is then mixed with a saturated sal-ammoniac solution, whereby the platinum is thrown down. This precipitate is boiled several times in water, in order to dissolve all sal-ammonia, and finally washed in hot alcohol, dried, and heated to a platinum sponge.

8. In order to obtain the gold still contained in the solution, saturated sulphate of iron solution in small quantities is poured in; if after repeating the operation no more precipitation is observed, a small quantity of the solution is taken out and a drop of tin solution in muriatic acid is added, by which any traces of gold still contained in it are betrayed by the precipitation of the purple-colored deposit, and in this case more sulphate of iron solution must be added, and the fluid left to stand quiet for a day. The obtained precipitate is then well washed, dried, and melted with a little powdered borax.

The analysis is now ended, and the obtained metals will weigh exactly as much as the original alloy, of course, if the process was prosecuted carefully.

Bric-a-Brac.

ONE OF THE rarest specimens of flambi porcelain in the city is a tiny vase the form and design of which are alike unique.

A beautiful group executed in bronze represents Hercules bearing Proserpina in his arms as he is conducted by Cerebus from the infernal regions.

A novelty in Worcester ware is an apple dish, which consists of two oval plates, the edges richly gilt, and on either side a cream pitcher and a tiny sugar bowl.

The best specimens of terra cotta ware come directly from Dieppe and are carved by some of the ablest artists of the day. Scenes from the life of the fishing population are realistically reproduced, and the carving when completed is mounted in a deep border of rich velvet, either black or crimson.

A handsome card-receiver is in the purest alabaster; in the center is a medallion of Leonardo da Vinci surrounded by smaller ones of Raphael, Gallo, Ariosto, and Tasso.

A most perfect specimen of native Japanese art is seen in a pair of porcelain vases expressly made for the exhibition at Tokio. Buddah and the goddess Benten are represented surrounded by poets, philosophers, and historians, a few nymphs attired in robes and mantles of gold and blue attending upon the deities. As usual in Japanese work of this kind every detail is carried out, and, although the faces are small, each has perfect individuality of expression. Both Buddah and his goddess are surrounded by a nimbus.

A sword which played its part in the Satsuma rebellion in Japan has a handle of curiously wrought iron work. The hilt represents a dragon, the scabbard is of lacquered red wood, and upon the handle the sacred mountain Fusyama is carved in silver.

In a newly imported specimen of Eastern carved ivory a theatrical group is represented, consisting of actors and musicians. The face of the principal actor is covered by a mask surmounted by the mythical dragon. One musician plays a flute, the other is energetically beating a drum, and the figures are all full of life and expression.

Very small square sandal wood-boxes are richly carved in representation of mythological scenes, and are finished off with a bordering half an inch in width in inlaid silver and ivory.

Old Italian oak is of the darkest and richest brown, and is very rare. A masterpiece of antique carving in this material is conspicuous upon the lid of a coffer, which is supported upon the shoulders of griffins with glaring eyes and fangs. Upon the front a sea piece, with Neptune riding his sea horses and triumphant over sea monsters, is wonderfully reproduced in carving.

A circular mirror from the Constantine palace in Rome is framed in dark Italian oak, exquisitely carved. Figures of sporting cupids peep out from rich, full foliage, and in their midst Jupiter's head appears as if crowned with the falling leaves.

Japanese silver-work is among the most beautiful of all, not only for the minute attention paid to detail, but because many metals are often used in combination with great effect. A moonlight scene, for example, is thus represented, the effect of varying light and shade upon hanging blossoms upon a cherry tree being conveyed in the varying tones of different metals. The background of the scene is shiboutchi metal, the moon in gold, and the blossoms in a paler shade of the same precious metal.

A very racy curio, made in bronze, richly worked and mounted on teakwood, is a Chinese incense burner. Upon a cover of the same material a representation of the dog Foo is beautifully carved in ivory.

Rests for carving knives are taking a novel shape. Between a pair of silver horses a bar of the same metal supports the knives.

Cabinets for bric-a-brac are found in every reception-room, and can be very readily ornamented at home. Very often they simply consist of frame-work and shelves of the most ordinary wood, simply carved in low relief and ebonized at home.

The bright yellow tint of many Japanese vases has never been successfully imitated by European artisans. Its popularity in Japan is no doubt owing to the fact that from time immemorial saffron tint has been considered lucky.

The grotesque would appear always to go hand in hand with the beautiful, and so we find side by side with the most exquisite terra cotta carvings a grinning skeleton carried out in the same material. To add to the ghastly effect a sleeping infant is in its arms.

A novelty in porcelain ink-stands takes the form of a shapely hand. The palm affords a receptacle for the bottle, while between the thumb and finger is an aperture for the pen-holder.

THE *Revue Chronométrique* gives the following assumptions of the world's consumption of watch crystals.

There are annually manufactured 2,500,000 watches, and for the last fifty years more than 70,000,000 have been placed in commerce. With these we may count a stock of old watches, at a minimum of 15,000,000; total minimum of 86,000,000 or 87,000,000 watches provided with crystals, which is really below the average.

New watches absorb about 4,000,000. Possessors break about one-fourth more, watchmakers and transport another fourth, which gives an annual consumption of about 47,000,000 of crystals.

To this we must still add that watchmakers outside of large cities, no matter how small he be, must always have at his command an assortment commensurate with the wants of his customers, and if count is taken of children's toy watches, medallions, surveyors instruments, etc., to all of which chevé or convex glasses are used, the astonishing result will be found that about 100,000,000 watch crystals are consumed annually.

Music Boxes.

SOME two years ago a paragraph in this column called attention to the subject of music boxes, giving a brief sketch of their construction, and expressing hope for some steps which should make them less a rarity than they have always been. This is brought to mind by a letter addressed by the Geneva Chamber of Commerce to the American Consul in that city, and forwarded by him, urging a reduction of duty. The manufacturers who sign this letter look upon this country as a vast field from which the 30 per cent. duty—levied upon all musical instruments—shuts them out. The value of boxes exported to the United States from Geneva is reported at \$1,038 for the first quarter in 1881, \$3,540 for the second quarter, \$7,385 and \$5,684 for the third and fourth; and as for the first two quarters of 1882, the figures were \$7,080 and \$1,062, a marked decline is seen. From the consular district of Geneva the exportation declined about three-fourths in 1873-'7, and has since been rising, but has hardly passed the position it had in 1873. On the basis of the figures reported for 1881, the revenue from music boxes would be about \$25,600 a year. In the cheaper grades, invoiced at Vevey, a large increase in exports appears, but the high class instruments of Geneva show a decline. The memorial urges that the duty is almost prohibitory, and is not at all protective, because the industry has not taken root in America, but that it has always remained in Switzerland, where it originated and probably will always remain there. As reasons for this belief the memorialists say that the mechanical or "movement" portion alone—the cylinder, train, wheels, etc.—is capable of being made by machinery, that "the making of the music on the cylinder, and the verification of the same, both operations having to be performed from the written music, require human intelligence to interpret the composer's ideas, and the finishing, above all, needs the care of an experienced musician to judge whether the effect produced is in accordance with that intended by the composer." The memorialists assert that three-fourths of the work must necessarily be performed by human hands, that several attempts to substitute mechanical labor have failed, and that labor is undeniably cheaper in Switzerland than in this country. Still we are not quite convinced. The music box—delicious as it is, even the toy specimens being grateful to the ear—is automatic and thoroughly mechanical, and, up to the work of inserting the spurs in the cylinder, the construction is as simple and easy as that of clocks, and perfectly well adapted to uniform work by machinery. Whether the skilled labor required for this last step, and the services of experienced musicians are so much cheaper in Switzerland as to dispose of the prospects for Americanizing the industry, is a question our watch-making companies might take up.

Cheap Aluminum.

THE FOREIGN report that a cheap process has been discovered of making the now costly metal aluminum is received with general incredulity. All inventions and discoveries proceed to their triumphs and choruses of doubts. There is no reason to question the announcement of the production of cheap aluminum except the worthless reason that all previous attempts of the kind had failed. The word "cheap" is here used in a relative sense. As a matter of fact the cost of aluminum has been greatly reduced since Sir Humphrey Davy produced little globules of it by electrolysis. It was then more costly than gold. Simpler methods of obtaining it brought down the price to \$8 an ounce. Since then it has dropped to \$1 an ounce; and by the quantity it may be had for even less. Here is shown a marked decline in the cost of production owing to more economic processes. Judging the future by the past, we see no good reason why aluminum may not be still further cheapened, until it fills the place of utility and ornament for which it is fitted by nature.

The earth has no more abundant metal than aluminum. But like iron, it is never found in its metallic state. It is always in an

ore form, as feldspar, cryolite, and above all, as common clay. Every clay-bank is a mine of aluminum. The clay is "cheap as dirt," and excavated with ease. It is the only ore of a metal obtainable without expensive digging and great dangers. No recent discoverers (prior to the last report) have been able to dispense with another metal—sodium—as the only reducing agent by which aluminum could be freed from its compounds. This sodium is the metallic base of common soda, and is itself a comparatively expensive substance, only to be procured by the destructive distillation of soda with charcoal in iron retorts at a high heat. The remaining steps, before aluminum is reached, involve great wastes of material and the frequent renewal of burnt-out retorts. The principal source from which the present scanty supply of the metal comes is the cryolite ore of Greenland, which if a double fluoride of aluminum and sodium. This is most easily operated upon by the reaction of metallic sodium. Any really cheap process should be one dispensing with the sodium and applicable to the limitless stores of clay which can be had all over the world for the shoveling. If anybody has hit upon such a process—as is not improbable, for it is sure to be found out some day—he has conferred a great benefit upon mankind.

At present, on account of its high price, aluminum has an extremely limited number of uses. It is most often seen as the tubes of opera glasses, for which it is suited by its marvellous lightness (weighing no more than pine wood), by its strength and tenacity, its retention of polish, and its entire freedom from rust and acid spottings. Being strictly unalterable in moist or dry air, it is well adapted for delicate weights and balances. For the same reason mathematical instruments of precision are made from it. Dentists profit by its lack of weight and hardness and rigidity to work it into mouth plates for holding teeth. Alloying it with a small percentage of copper produces the beautiful aluminum bronze. This has the color of gold, is untarnished by fruit acids, and is in all respects an appropriate material for knives, forks and spoons, as well as for purely ornamental forms. The expense of the alloy, as of the chief metal, has hitherto barred it from general use. A copious supply of aluminum would be welcomed for decorative purposes as for household implements. But if it could be sold at a price very near that of iron it would go far to supplant that metal for objects where lightness combined with strength and practical imperishability are desired. Its substitution for iron or steel in railroad bridges, car wheels, water pipes, carriage fittings and cannon is barely suggestive of the hundreds of services to which it could be put. When the metal is obtained in quantities sufficient for free experiment, important uses now undreamed of by the wildest imagination, will be found for it.

Coloring Gold Articles.

GOLD ALLOYS, especially those containing copper, assume an unsightly dark brown exterior, owing to the copper oxide generated by the repeated glow-heating during work. In order to remove this, the object must be pickled, and either highly diluted sulphuric or nitric acid is used for the purpose, according to the color the article is designed to have.

If working with an alloy consisting only of gold and copper, either sulphuric or nitric acid may be used indifferently, since gold is not attacked by any one of these acids, while copper oxide is easily decomposed thereby, and after having been pickled, the article will assume the color of pure gold, because its surface is covered with a layer of the pure metal.

If the alloy is composed of gold and silver, however, only nitric acid can be employed, and the article is left immersed in it only for a short time; this acid dissolves a very small portion of the silver, and the article also assumes the color of pure gold.

When working with an alloy which, beside the gold, contains both copper and silver, the process of pickling may be varied in accord-

ance with the color desired to be given to the article. If the pickling is performed in sulphuric acid, only the copper alone is dissolved, the article assuming a color corresponding to a gold-silver alloy, which now constitutes the surface of the article.

If nitric acid is used, it will dissolve the silver as well as copper, and in this case a pure gold color is produced.

Pickling is done by first feebly glow-heating the article and cooling it; this operation is for the purpose of destroying any fat from the hands or other contamination adhering to the article. If it was soldered with some easily-flowing solder, this glow-heating must be omitted, but it may be cleansed from impurities by immersing it at first into very strong caustic lye, and rinsing it with water; it is then laid into the acid.

The acids are employed in a dilute state, taking forty parts water to one part concentrated sulphuric or nitric acid. If more articles than one, they had best be laid aside of each other in a porcelain or stoneware dish, the diluted acid is poured over them, and some article is lifted out from time to time to watch the course of proceedings, whether it has assumed a yellow color.

When to satisfaction, they are rinsed with clean water and dried.

While pickling for the purpose only of causing the color peculiar to gold to appear, the process of coloring has for its object to lend the appearance of very fine gold to an article of an indifferent alloy. Various mixtures may be employed for the purpose, and we give two recipes below which are very appropriate:

Mix 2 parts saltpeter, 1 part table salt and 6 parts alum with $6\frac{1}{2}$ parts water, and place it into a porcelain dish for heating. As soon as you notice that the mixture begins to rise, add 1 part of muriatic acid, raise the whole to boiling, and stir with a glass rod.

The article to be colored, and previously treated with sulphuric acid, as specified, is suspended to a hook, either of sufficiently thick platinum wire or glass; it is then introduced into the rather slow boiling bath, and moved around in it. It is to be taken out in about three minutes, and rinsed in clean water, inspecting its color at the same time. If not to satisfaction, it is returned to the bath, and this withdrawing and re-introducing is repeated until the desired color is obtained. By the latter immersions the article is left only one minute at a time in the fluid.

When sufficiently colored, the article, after rinsing, will be of a high yellow and mat color; it is washed repeatedly in water to remove the last traces of the bath, and then dried between soft and heated sawdust.

In place of drying in sawdust, the article may also be dipped in boiling water, leaving it in for a few seconds; the adhering water will evaporate almost instantaneously.

The second coloring method consists in pouring water over a mixture of 115 parts white table salt and 230 nitric acid, so that the salt is dissolved; it is then to be heated until a dry salt residue is again present. This residue is mixed with 172 parts fuming muriatic acid and heated to boiling, for which purpose a porcelain vessel is to be used.

As soon as the pungent odor of chlorine gas begins to evolve, the article to be colored is immersed, and left for about eight minutes in the fluid for the first time; in other respects, a similar treatment as specified above, is used also for this method; if the article colored was polished previously, a subsequent polishing is unnecessary.

On account of the vapors evolved by the coloring baths, which are very dangerous to health, the operation should be performed either under a well-drawing flue, or what is still better, in open air.
—[*Goldschmiedekunst.*

Important Discoveries.

Aluminum, a metal, the base of the earth's alumina, which is combined with silica in clay. It is very light, malleable, and sonorous, was made into watch cases by Messrs. Reid & Newcastle, in 1862.

Amber, a carbonaceous mineral, principally found in the northern parts of Europe, was highly prized by the ancients. Theophrastus wrote upon it in 300, B. C.

Amethyst, the ninth stone upon the breast-plate of the Jewish high priest, 1491, B. C. It is of a rich violet color.

Barometer.—Torricelli, a Florentine, having discovered that water did not rise in a pump, thought and supposed to be Nature's abhorrence of a vacuum, imitated the action of a pump with mercury, and made the first barometer about 1642, wheel barometers were invented in 1668, pendent barometers in 1695, marine in 1700, and many improvements have been since made. In the *auroride* barometer no liquid is employed, the atmospheric pressure being exerted on a metallic spring. Its invention is attributed to Conté, in 1798, but due to Vidi.

Bells were known to the Jews, Greeks, and Romans; they are said to have been introduced by Paulinus, bishop of Nola, in Campagna about 400—and first known in France about 500.

Bismuth was recognized as a distinct metal by Agricola in 1529. It is very fusible and brittle, and of a yellowish white.

Blow-pipe.—An Egyptian using one is among the paintings on the tombs of Thebes. It was employed in minerology by Audra Von Swab, a Swede, in 1733, and improved by Wollaston and others. In 1802 Professor R. Hose, of Philadelphia, increased the action of the blow-pipe by the application of oxygen and hydrogen. By the agency of Newman's improved blow-pipe in 1816, Dr. Clark fused the earth's alkalies, metals, etc.

Borax was known to the ancients, is used in soldering, brazing, and casting gold and other metals, and was called chrysocolla. It is found in India, Saxony, Tuscany, and America.

Brass was known among all the early nations, the Corinthians from the remotest ages were acquainted with its use, so were the British.

Bronze was known to the ancients, some of whose bronze statues, vessels, etc., are in the British Museum. Bronze is composed of copper and tin, with some little zinc and lead.

Buckles were first worn instead of shoe strings in the reign of Charles II., and became valuable and expensive from the richness of their material.

Bucklers were invented by Proetus and Acrisius of Argos, about 1370, B. C.

Cadmium, a metal, was discovered by Stromeyer in 1818.

Caliper Compass was invented by an artificer of Nuremberg in 1540.

Candlesticks are first mentioned in Exod. xxvii., 27. A candlestick of pure gold for the tabernacle, B. C., 1491. Candlesticks were used in England in the days of King Edgar, 959.

Carbon was shown to be a distinct element by Lavoisier in 1788. He proved the diamond to be its purest form, and converted it into carbonic acid gas by combustion.

Cerium, a very rare metal, discovered by Klapproth in 1803.

China Porcelain introduced into England about 1531.

Chromium, a rare metal, discovered by Vanquelin in 1794. It is found combined with iron and lead, and forms the coloring matter of the emerald.

Chronometer discovered by Harrison in 1714.

Chronoscope, an instrument invented by Wheatstone in 1840, to measure small intervals of time.

Clarionet, a wind instrument, invented by Denner, of Nuremberg, in 1690.

L. Eggerton has severed his connection with the E. N. Welch Manufacturing Co., and has entered the service of the E. Howard Watch and Clock Co. Mr. Eggerton is a gentleman of large experience, and is universally popular throughout the trade.

Clepsydra, a water clock, was introduced at Rome about 158, B. C., by Scipio Nasica.

Clocks.—Tooth wheels were applied to clepsydres by Ctesibius about 140, B. C., said to have been found by Cæsar on invading Britain, 55, B. C. The only clock supposed to be then in the world was sent by Pope Paul I. to Pepin, king of France, A. D., 760. Pacificus, arch-deacon of Genoa, invented one in the 9th century. The earliest complete clock of which there is any certain record was made by a Saracen mechanic in the 13th century.

The adaptation of the escapement is ascribed to Gerbert, 1000. A great clock put up in Canterbury cathedral, costing £30, 1292.

A clock constructed by Richard, Abbot of St. Albans, 1326.

John Visconti set up a clock at Genoa, 1353.

A striking clock in Westminster, 1368.

A perfect clock made at Paris, by Vick, 1370.

The first portable clock was made in 1530.

In England no clock went accurately before the one set up at Hampton Court (maker's initials N. O.) 1540.

The pendulum is said to have been applied to clocks by young Galileo, in 1639, and by Richard Harris, who erected a clock at St. Paul's (Covent Gardens) 1641.

Christian Huyghens contested this discovery, and made his pendulum clock some time previously to 1658.

Fromantil, a Dutchman, improved the pendulum about 1659.

Repeating clocks and watches invented by Barlow about 1676.

The dead beat and horizontal escapements were invented by Graham about 1700. The compensating pendulum 1715.

The spiral balance spring suggested, and the duplex escapement invented by Dr. Hook. Pivot holes jeweled by Facio. The detached escapement invented by Mudge and improved by Berthould, Arnold, Earnshaw and others in the 18th century.

Harrison's time-piece constructed in 1735.

The British Horological Institute established in 1858.

The great Westminster clock set up on 30th May, 1859.

Clock-makers, Company was established in 1632.

Coin.—The invention of coin is ascribed to the Lydians, whose money was of gold and silver, 862, B. C. Homer speaks of brass money as existing 1184, B. C. The most ancient known coins are Macedonian of the 5th century, B. C.

Columbium, a metal discovered by C. Hatchett, in a mineral named columbite, in 1801. It is identical with niobium.

(To be Continued.)

A Remarkable Pair of Diamonds.

THE *Evening Post* of this City recently published a description of a most remarkable pair of diamonds, now in the possession of E. August Neresheimer & Co. The article also gives a romantic history of these gems, for the truth of which we cannot vouch, as we can for the wondrous beauty of the diamonds. These are a pair of old Indian-mine diamonds, cut in cushion shape, weighing eight and one-half karats each, and of a remarkable pale blue color. Their tint is far deeper than "steel blue," but much lighter than the sapphire blue of the celebrated Hope diamond. They are so full of fire that many a pure white diamond is dimmed by contrast with them, and so absolutely perfect that the slightest flaw cannot be discovered in either by the aid of the most powerful magnifying glass. Their combined weight of seventeen karats is almost exactly divided between the two, they are alike beautifully proportioned, and the peculiar shade of blue is precisely the same in each. In all respects the quality of the two is identical. Their hue is of a kind that is usually found only in very small and imperfect stones. So completely are they "twins," that experts do not doubt but they were originally one stone, and have been divided for some reason, probably because the original shape was such that could not be cut to advantage as a single stone without great loss in weight, while it was susceptible of division.

Whatever reason may have influenced the original owner to divide the stone, certain it is, that the result gave to the world a most magnificent pair of perfectly matched gems, that it would be utterly impossible to duplicate. Their early history is enshrouded in mystery and attended with romance, as is that of all the most valuable gems known. According to the published account, the probability is that they were "looted" by Warren Hastings, when Governor General of India, from some of the petty rulers in that country. Subsequently they fell into the hands of a Russian nobleman, who afterwards became a political exile. In order to support himself in foreign lands, he was forced to sell his jewels, and thus these diamonds became separated. For many years one of them was known in the markets of Europe, changing hands at long intervals, but its mate had disappeared until the fact that there was a pair of them became almost forgotten. Some time ago, Mr. Neresheimer's agents in Paris, succeeded in purchasing one of the stones, and forwarded it to the house in New York, where it has been greatly admired as a single stone. Recently one of the members of the house, while in Chicago, was astounded to see the mate to their famous diamond glittering on the shirt front of a resident of that city. Negotiations were opened with the owner for its purchase, and his reluctance to part with it was finally overcome by the liberal inducements offered. Thus the "twins" were re-united after many years of separation and adventurous wanderings, and have now found a home in the new world that has learned to appreciate such rare and beautiful gems. We do not vouch for the romantic story of their adventures as related in the *Evening Post*, but that they have been held in high favor in the past by Oriental princes and civilized royalty may well be believed.

To the Retail Jewelers of Wisconsin.

YOUR ATTENTION is called to the fact that the Third Semi-Annual Meeting of the Wisconsin Retail Jewelers' Protective Association will be held at Oshkosh, Wednesday, Feb. 14, 1883.

These meetings are held in your interest, and it is hoped that you will be interested enough to be in attendance on this occasion, thus showing that you deem them beneficial and important.

You have long been aware that the Association was doing a good work, for the catalogue nuisance has been virtually abandoned by jobbing trade so far as outsiders are concerned, and nearly all the prominent jobbers in issuing their circulars have a prominent notice in them that they solicit the patronage of the legitimate trade only.

Such being the case, does it not stand us all in hand to become members of the Association, if not members already, and does it not prove that all who are members should remain such and remain firm and steadfast in living up to its rules and regulations?

Your business has been sadly interfered with by the outside trade owing to the greed of certain jobbers who have endeavored to increase their sales by getting outsiders to handle goods in our lines, and this outside business is still going on, owing, in a great measure, to the indifference and apathy of the retail trade, including a number who are members, who are in the habit of patronizing such jobbers as do not stop catering to the Dry Goods, Clothing and Fancy Goods Stores.

Don't you think it is about time to be more discriminating, and give your patronage to such jobbers as sell to the legitimate dealers only?

It is hoped you will make an effort to attend this meeting, and if not already a member, become one, and contribute your mite to support and maintain an organization formed in the interest of your line of business. There will be considerable business to transact at this meeting, so be good enough to be present and render what aid you can to have all necessary business transacted in a proper manner. Remember you are interested in this work, whether you have ever appeared so or not, so do not remain at home, and after the meeting say that the Association is not carried on in the right manner.

Delegates to the U. S. Guild are to be chosen, so come out to the meeting and send the best men you can to represent this State at the National Meeting.

The matter of Auctions and Peddlers will be brought up at this meeting, and an effort made to devise the best means to suppress the evils, if evils they are declared to be.

Finally, do not forget the date, but make a minute of it, and make up your mind to be present at the coming meeting.

Yours fraternally,

W. H. THORP, Sec'y.

Dated, Beaver Dam, Wis., Jan. 20, 1883.

Galvano-Plastic Art.

BY EXPERT.

ONE OF the most beautiful and effective uses of electro-deposit is the production of panels in copper from relief carvings, either in wax or plaster. We will first assume that we are to produce a panel in relief in copper electrotype. The first (and all things considered, the best) method is to prepare a plate or sheet of wax of the size of the panel to be made. The manner of preparing such a sheet can be conducted in several ways; but any plan by which a sheet or plate of wax, $\frac{3}{8}$ of an inch thick, and say 8 by 12 inches square, can be produced, with one side perfectly flat, will answer. A good method is to put a frame around a plate of glass of the size required, and casting in the melted wax. French plate is the best, but ordinary good crown or window glass will answer. The frame (of wood) should be made so as to be detached by taking the pins out of two of the corners. A plate of glass of nearly the same size, say $\frac{1}{4}$ of an inch smaller than the lower plate, should be put so as to afford a back to stiffen the wax. To explain the details, fig. 1 is a plan of the frame and top glass, and fig. 2 is a transverse section of the same on the dotted line *d*. Assuming the size above given as the one in hand, the lower plate of glass shown at *c*, fig. 2, must exceed the dimensions (8×12) by one-fourth of an inch all around, so that the plate *c* should measure $8\frac{1}{2} \times 12\frac{1}{2}$, and the frame composed of four pieces one inch square, shaped as shown at fig. 3, in cross section; this section is magnified above, figs. 1 and 2. This frame should be joined by tenons at the corners, and two of them

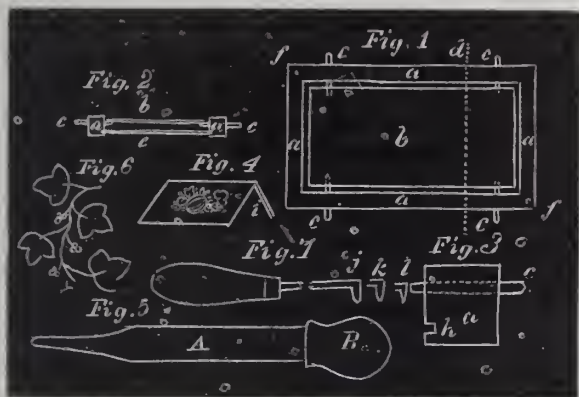

should have loose pins as shown at *ff*, fig. 1, so as to take apart. The outside dimensions of the frame should be $9\frac{3}{4} \times 13\frac{3}{4}$ inches. This size allows a groove $\frac{1}{8}$ of an inch deep to be cut in the frame for the lower plate of glass to go into as shown at *b*, fig. 3. At *cccc*, fig. 1, are shown four pins passing through the frame as shown at *c*, fig. 3; the top of these pegs should be $\frac{3}{8}$ of an inch above the upper surface of the lower plate of glass.

Suppose the frame *a* pinned together, and the lower plate *c* in place; set the frame level and pour in melted beeswax (prepared as described below), until it rises above the pegs *cccc*. Now lay the plate of glass *b* on the pegs and the wax will rise and flow over it either wholly or in part; it is not necessary that the wax should entirely flow over *b*, but there should be surplus wax enough so that as it cools and shrinks there will be enough wax to supply the deficiency. The lower glass should be oiled slightly before the wax is poured in, so that it will readily detach itself from the wax. Wax for this purpose should be mixed with some pigment to enable one to judge of the depth of the cutting, as in this case we are going to make an *intaglio*, and cast the copper into it. There are various pigments which can be used to color the wax, but on several accounts lamp black is the best, Indian red next; other colors may do as well or better perhaps, but lamp black is good enough; it should be mixed with melted (white) beeswax, in the proportion of one part of lamp black to five of wax, by weight. These proportions do not always hold good, either from irregularity in one or the other of the constituents, probably the lamp black in one case absorbing more of the melted wax in the particles.

A sure method is to mix thoroughly with the melted wax as much

lamp black as to allow of its being poured into the frame and manipulated as described above. After the wax has become perfectly cool and the frame taken apart, the glass *e* removed (but *b* remains to stiffen and hold the wax flat). The design should now be traced on the wax and scraped in, *sinking* the figures just as you desire to have them *raised* in the electrotype cast. The advantage in proceeding in this way is to have the flat surface of your wax as the ground, or base of the work, and the relief you desire to ultimately obtain, is produced by cutting deeper and deeper into the wax. Should we proceed to model direct in relief it will subject us to two operations; first the model, next a cast, and then making the final electrotype. If the pupil is a good draughtsman, he will soon learn to judge of the necessary depth to produce the relief desired; if not, some simple design should be selected, like fruit and leaves.

The position for work is to set the panel at an angle, and support it with props as shown at *i*, fig. 4. There is no art process which can be worked more rapidly and satisfactorily than this, it admits of so many rapid ways of producing results. When scraping and lining the position shown in Fig. 4 is the best, but for some manipulations let it lie flat and melt the wax with a hot piece of wire, and while fluid suck the melted wax up with a pipette which has an India rubber ball on top—the instrument is precisely like the one used to fill a Mackinnon pen, only the part *A*, fig. 5, should be of metal, although a glass one will answer. This peculiar and somewhat queer tool can be used to produce some beautiful effects, and with astonishing rapidity. The final finish is given with hand tools of various shapes, some of which are shown at fig. 7. The pipette can be heated and made to deposit the wax it contains in a great variety of forms, and if made of metal can be heated and used to melt the wax as well as suck it up. We will suppose we are making a wreath of ivy, a portion of which is shown at fig. 6. After outlining, an empty heated pipette is drawn through the wax to correspond to the vine, and the margin of a leaf followed and the whole of the leaf made liquid by zig-zagging across it, and when the liquid wax is taken up, a recess will be left of the size and shape desired. A few rapid and skilful tool marks and a mould is made which will produce when, electrotyped, relief figures at one-fourth the labor that would be required for direct relief.

Some panels of electrotype are now made in Europe for cabinets of exquisite art and finish. A panel of this kind was recently seen by the writer in an imported cabinet, which contained upwards of fifty full length (of course in miniature) figures, representing a wedding scene; and so skilfully was the work executed that the expression of the faces were given to perfection, even to the self-important look of the groom, and modest, upturned look of the bride—clinging and trustful—the half swagger of the groomsmen, and the titter of the fluttering bridesmaids. After the wax tablet is cut and finished, ready for the electrotype process, an excellent idea of how it will look when cast can be obtained by pouring alcohol over the flannel, then pouring off and drying with a soft napkin. The whole panel can be now coated with gold bronze—so called, but it is in reality a species of fine brass ground to extremely fine dust, and each particle retaining its metallic luster. Bronze known as No. 5,000 should be used, as it is the finest made; use no other. Turn your tablet bottom-side up and look at it in a mirror, and a good idea can be obtained of how it will appear when cast in copper and gilt, or nickel plated. This bronze coat makes the surface conductive, and the electrotype copper can be cast directly on it.

There is another method of testing the relief, which, if the panel is an elaborate one like the wedding scene described, answers quite as well or better. If your cutting is in black, as directed above, lay the flannel flat and level after washing with alcohol (need not dry it as before), and pour on the face of it a mixture of milk and water (four parts water to one of milk), so as to fill all the depressions cut in, and slightly flow over the flat face of the wax panel. Now, of course, the deeper the cutting the whiter the fluid appears, and in this way you obtain a proof of the relief in the work, not only as to

the individual parts (if I may be allowed the expression) but the effect of the whole group.

The wax tablet, when the cutting is satisfactory, should be coated with black lead and immersed in sulphate of copper solution. I cautioned the reader about the relative size of bath and battery. The copper surface opposite the wax mould (panel) should be of the same size, and the distance between the two at least one foot.

Annual Banquet of the Chicago Jewelers' Association.

THE MEMBERS of the Chicago Jewelers' Association celebrated their sixth anniversary on December 28, with their customary annual banquet at the Tremont House in that city. The banquet-hall was handsomely decorated, while the tables were handsomely set forth with elegant table furniture, bouquets and ornamental pieces illustrating the artistic and gastronomic skill of the *chef de cuisine*. Mr. Kearney, President of the Association, being prevented by illness from attending, Otto Young, Vice-President, presided over the festivities of the evening.

The menu was an elegant affair, printed on satin mounted on heavy cardboard, and gave promise of a sumptuous repast, the fulfillment of which was fully redeemed by practical illustration. The courses were numerous, substantial and enjoyable, and fully sustained the high reputation of the Tremont House. Ample justice was done the repast by all present, pleasant conversation being carried on simultaneously with the satisfying of the inner man. Carnal appetites having been abundantly satisfied, fragrant Havanas were introduced, and then began the "feast of reason and the flow of soul," to which the excellent wines provided materially contributed.

Order being called for, Vice-President Young extended a cordial welcome to the guests assembled, and in a few well-chosen words, commented on the condition of the trade, representing that the transactions of the year just closing had been of a nature generally satisfactory. He likened the members of the trade in Chicago to an army in camp, from which scouts were sent out to scour the country and ascertain its necessities and its capacity for consumption, and when their reports were received, the camp was put in motion to provide them with ammunition and supplies with which to carry on the campaign. Thanking the guests for their presence, he bid them welcome in the name of the Association.

The first toast of the evening, "The President of the United States," was responded to by Hon. F. W. Palmer, who spoke in highly complementary terms of President Arthur, and in concluding, gave as a sentiment, "Liberty and law; while they shall remain inseparable, the Republic will continue unconquerable."

To the toast "The City of Chicago; it speaks for itself," Hon. Carter H. Harrison, Mayor of the city, responded in an eloquent address and humorous speech—evidently a new one—wherein he poked considerable quiet fun at some of the other guests and members of the Association. His witty remarks elicited much laughter and applause.

The Hon. William Bross, ex-Lieutenant Governor, and one of the proprietors of the Chicago *Tribune*, responded for the press, and in a quaint manner replied to some of the badinage of Mayor Harrison; he also paid a high compliment to the press of the city, and thought it was on a higher plane than the average reader.

Rev. Dr. Hirsch responded for "Arts and Science," in a few remarks highly complimentary to the trade.

In response to the toast "Statesmanship," Hon. Emery A. Storrs made a speech characteristically pointed and humorous, in which he replied to the personal persiflage of some of the other speakers in a manner that showed him to be a master of extemporaneous repartee.

Rev. Dr. Thomas responded for "The Clergy," and William H. Moore for "The Bar," in words of pleasant humor, and John V. Farwell answered for "Our Guests," in a brief but happy vein. Frequent bursts of laughter greeted the witty sallies of the various speakers, and the utmost good humor prevailed. When the last toast had been responded to, Mr. Hale moved a vote of thanks to the speakers of the evening, which was unanimously adopted with much cheering, after which the members and their guests adjourned to the reception room, where a short time was spent in social chat. On the whole the occasion was a most enjoyable one throughout, reflecting great credit alike upon the committee having it in charge, and the Association as well. It was in every respect one of the most enjoyable social events of the winter in Chicago.

Celebrating the Production of the 2,000,000th Watch.

A UNIQUE celebration was indulged in on the evening of January 6, at Young's Hotel, in Boston, by the foremen employed in the various departments of the Waltham Watch Factory. The occasion of the celebration was the production at the factory of the 2,000,000th watches made by the company, a watch legitimately bearing that number having just been completed. The foremen deeming such an event worthy of commendation, formed themselves into an organization (which was subsequently made permanent) and arranged for a banquet at Young's Hotel. At the appointed time, the foremen, with a few invited guests, assembled at the hotel designated, where a bounteous repast, prepared in that elegant manner for which Young's Hotel is noted, awaited them.

Mr. Fisher, being President of the Association, occupied the chair at the head of the table, and at his right sat Messrs. Robbins, Treasurer of the Company, Woerd, Shirley, Church, March, Bond, Sawin, Olney, Wills, Shepard, Howe, Burnham, Mulloy, Greene, and Finnier, in the order given; and at his left, Messrs. Fitch, of the firm of Robbins & Appleton, Smith, O'Hara, Keyser, Haines, Berlin, Proctor, Lynch, Buncher, Moore, Hammond, Thomas, Eaton, Bates, Lord and Wren, Mr. Rogers occupying the seat at the other end of the table.

After ample justice had been done to the tempting viands, the President, in a few brief remarks, announced the purpose of the meeting. He said: "We are assembled for a purpose, the cultivation of the social element, and to commemorate the completion by the company in whose employ we are, of two million watches. Very few people have any conception of the amount of study, time, capital and business tact which have been required to accomplish this result, and certainly no one knows those facts so well as the gentlemen under whose management the company has prospered so many years. I propose the health of the treasurer of the American Watch Company, R. E. Robbins, Esq."

In response Mr. Robbins gave a general statement of the early struggles of the company and more especially just prior to and during the war, in the course of which he dwelt very pleasantly upon the relations existing between himself and the foremen and others connected with the business, relating one or two incidents which were extremely interesting and instructive to all.

The president then in a few well chosen words introduced Mr. Fitch, of the firm of Robbins & Appleton, who very aptly responded in a happy and humorous vein. Mr. Smith of the Boston office followed and read a telegram received from New York, where the salesmen were enjoying a dinner given them by Robbins & Appleton, the occasion being the departure of Mr. Manson, the company's agent to Australia. The telegram as read by Mr. Smith was as follows:

NEW YORK, January 6th, 1883.

E. C. Fitch and Waltham friends, Young's Hotel, Boston,—Robbins & Appleton, dining in New York, enthusiastically drank the health of Royal E. Robbins as the founder of the business to whose enterprise, energy and ability is due the success of watch manufacturing in America.

[Signed] ROBBINS & APPLETON.

Mr. Smith then announced that the following answer had just been wired to the salesmen in New York:

To Mr. Appleton's Dinner Party,—

The American Watch Company's Foremen and their guests tender their heartiest congratulation. We are all *dial* up, sober and sorry for it.

[Signed] AMERICAN WATCH CO.

Speeches were also made by Messrs. O'Hara, Greene, Thomas, Lynch, Moore, and others, while a nameless person read a carefully prepared impromptu poem punning on the names of the foremen. The speeches all abounded in wit and humor, and all paid deserved tribute to the ability, goodness of heart and uniform kindness of R. E. Robbins, the founder of the company. The event was most enjoyable in every respect, and was the first of what we hope will be a long series of annual social gatherings of the trusted employees of the American Watch Company. At the conclusion of the banquet the foremen returned to Waltham by a special train, and subsequently formed a permanent organization for social and educational purposes.

Proceedings of the Horological Club.

A DISTINGUISHED BODY OF WATCH AND CLOCK MAKERS.

One hundred and fourth Discussion.—Communicated by the Secretary.

[NOTICE.—Correspondents should write all letters intended for the Club separate from any other business matters, and headed "Secretary of the Horological Club." Direct the envelope to D. H. Hopkinson, Esq. Write only on one side of the paper, state the points briefly, mail as early as possible, as it must be received here not later than the eighth day of the month, in order to be discussed and reported in the CIRCULAR for the next month.

BLANCHING NICKEL MOVEMENTS.

Secretary of Horological Club:

I would like to ask your honorable body the best method of blanching nickel without destroying the enamel in the letters of names and indices. A workman for a firm in your city has a process that makes movements look almost like new, and he cherishes it as the apple of his eye. Would not "Excelsior" rise and elucidate this *modus operandi*. Respectfully, DYNAMICS.

Mr. Clerkenwell stated in reply that nickel was amenable to the same cleaning processes as gilt movements, but with a little more difficulty, owing to its hardness. It is generally supposed that nickel is but little liable to tarnish. That is a great mistake, as it is far more liable to be affected by exposure to moisture, handling, etc., than gilding. In fact, it is almost as bad in that respect as iron, to which it is very similar in its chemical reactions. So far as is publicly known, the best means of cleaning nickel are mechanical in their nature. That is to say, it is best done by the use of polishing powders. These should not be used dry, however, as the nickel would all be worn off before a polish was attained. Nor would moisture make the action any better. Either soap and hot water, or, what is better, a very little oil on a piece of buff leather, mixed with the polishing powder, should be used, finishing with the soap and water, or the alcohol bath. A mere trace of oil on the tip of the finger, gently rubbed over the parts, will readily loosen and remove the dirt and tarnish, after which the oil could be removed as usual. As regards referring the matter to "Excelsior," it so happened that he had already had a talk with the eminent horologist upon that very subject, and had been assured by him that there was nothing accessible to the trade which would do the work more perfectly and quickly than a little saponaceous or oily substance and polishing powders, with gentle rubbing, as already described. He (Excelsior) stated that he was himself accustomed to use a special chemical preparation for cleaning nickel, but as it was not to be had in the market, and could be properly prepared only by a professional chemist, it would be useless to give the formula for making it. Our friend "Dynamics" may therefore conclude that the process followed by the workman he mentions is doubtless the one already described, that of careful polishing with crocus and a little oil. Excelsior also stated that a good powder for polishing up nickel was finely powdered and sifted unslacked lime, used on a buff wheel with a little oil. The best lime for this purpose was obtained near Sheffield, England, but many limes found in this country were very good. It should be kept tightly corked in bottles or jars to exclude the air, and only a little powdered at a time as wanted.

EFFECT OF COLD ON WATCH AND CLOCK OIL.

Secretary of Horological Club:

I would be pleased to have some member of the Club inform me how low a temperature good clock and watch oil ought to stand without congealing. Respectfully, W. S. W.

Mr. Horologer replied that "good" clock and watch oil should not congeal at all at any temperature to which timepieces are ordinarily exposed. Oils are naturally composed of two parts—a solid and a liquid; and the proportions of the two determine how thick the mixture or "oil" will be. In purifying or preparing it for horological uses, the solid portions are removed more or less completely—according to the purpose for which the oil is designed. Watch oil is of course made thinner than that for clocks or heavier machinery, which requires "body" to prevent its being pressed out from between

the journal and its bearing, and leaving them practically dry. If made too thin, watch oil spreads and runs over the jewels, plates, etc., instead of remaining upon the pivots where it is placed. Manufacturers try to hit the happy mean between thick and thin. Watch oil will therefore stand a lower temperature than clock oil, before becoming perceptibly thicker, but even clock oil should not "congeal" at any ordinary temperature. If it does, Mr. W. should try some other "brand."

NEW ROLLING MACHINE FOR COUNTRY JEWELERS.

Secretary of Horological Club:

I send herewith photos of a rolling machine I have, and ask the opinion of your distinguished body in regard to it. It is thoroughly practical. I have been using it over three years, and found it to fill all the requirements of a country shop. I find it particularly useful in working over old chains, bracelets, etc., that are found in almost every family, and that they wish made into a ring or something useful. I have found a great deal of this to do in every place I have been. This old jewelry is generally a keepsake of some kind, and they are not willing to scold it off. The machine I have is the only one I have had made. It cost me, including patterns, about \$18. I want to know if you think it would sell, and if I could have it made cheap enough to place it in the hands of country jewelers.

It would not pay a jeweler to make his solid rings from coin, but the country jeweler often gets hold of old gold that he can get more out of that way than any other, and he can do it in spare time—which he often has plenty of.

If I put it on the market I would put out at the same time a small pamphlet of a few pages, explaining the capabilities of the machine, the quickest way and easiest of working gold in small quantities, and how to make those things which I have found by experience a man in that business would be called on to make, and embrace practically all the points of the thing on a small scale. Yours etc.,

W. G. SCOTT.

Mr. Rolliver, who had examined the photos and accompanying description, said it appeared to be a thoroughly practical device. It consisted of a frame to be fastened to a table or bench, an upper roller worked by a lever, a lower one having the pattern or shape formed on it as usual, and a wedge-shaped slide underneath for adjusting the lower roller to or from the upper—the two being connected by pinions fastened on the ends of the roller arbors by pins, so that the pinion could be changed to different rollers, and avoid cost of several pinions. The lower roller was arranged to be easily taken out and replaced. Altogether it was a very compact and convenient arrangement. But he would not venture to say that it would pay Mr. S. to put it on the market. That could only be told by trial. Mr. S. could either correspond with some leading dealer in jewelers' tools about manufacturing and selling it, or he could make them himself, advertise, and fill orders sent him by mail. Or he could interest some traveling agents in their sale.

TO THOSE WANTING EXCELSIOR'S ARTICLES, OR "PRACTICAL HINTS ON WATCH REPAIRING."

Secretary of Horological Club:

In accordance with your recommend, I shall present my apprentice with a copy of Excelsior's "Treatise on the Balance Spring, and the Adjustments of Watches and Chronometers," as a Christmas gift. I enclose \$3.50—please send it at once. I consider it worth its weight in gold—yes, in diamonds, to any apprentice, or for that matter, to any workman, young or old. Now I want to get the rest of Excelsior's articles, called "Practical Hints on Watch Repairing," published in THE CIRCULAR. I understand that the publisher cannot supply the back numbers. How can I get them. Please reply soon, and oblige, Yours respectfully, M. M.

Mr. Isochronal explained that the desire to obtain Excelsior's articles had been so general as to rapidly absorb the large number of extra copies printed. It was expected that these articles would soon be revised and republished in book form, in compliance with the very unusual demand for them. But as their author was engaged in working up some electrical inventions, it was impossible to tell when that would be done. At present, therefore, the only way to obtain them was to secure back numbers from some fortunate subscriber. Although we have, for several years, repeatedly requested anyone having the numbers containing them, and who would sell them, to

send us notice, with their price for them, we have never had a single offer till this month. We have at last found an owner who would sell. Mr. A. S. Van Dusen, Weavertown, Warren Co., N. Y., writes us that he has Vols. 11, 12 and 13, complete, clean and in good condition, and his partner has seven volumes, including those named. He offers his for sale, and we suppose his partner would dispose of his. The articles by Excelsior, on wheels, pinions, toothed gearings, etc., the best practical articles he had ever seen on the subject, began, he believed, in Vol. 10 of THE CIRCULAR, and ended in Vol. 12. But the "Practical Hints on Watch Repairing," which are not included in the book already published, (the "Treatise on the Balance Spring," etc., which included only the first series of Practical Hints), began in 1876, or Vol. 7 of THE CIRCULAR, so that the volumes owned by Mr. V.'s partner would probably include the whole of them. As we have repeatedly spoken in the highest terms of these articles, and their value to every practical workman, we need not say more than to inform the many who are constantly inquiring for these papers, of the opportunity at last to obtain them.

MAKING JEWEL SETTINGS AND BUSHING PIVOT HOLES.

Secretary of Horological Club:

Please inform me how to bush pivot holes in a workmanlike manner. Also, when pivot holes are to be bushed, so you can cut a new setting, how do you center the bushing correctly? Can you buy bouchons, or do you have to make them? By answering you will confer a favor on
CHUCK.

Mr. Ruby Pin replied that the piece to be bushed was first secured in the lathe, with the place for the pivot hole properly centered. The place for the pivot hole can be taken from the old hole, or found by striking two curves from the holes on each side with the depthing tool, as described by Excelsior in his Practical Hints on Watch Repairing. The bushing can then be done in different ways. A piece of brass may be inserted in the setting and turned off to resemble a jewel; or a hole can be cut through the plate, a plug fitted in tightly, and then turned off and drilled; or the plug may be driven in before the part is put on the lathe, the place for the hole marked on it with the depthing tool, then centered in the lathe by that mark. By means of a set of freeing tools and an upright drill, a very fair job can be done without a lathe.

When both a jewel and its setting are to be inserted, much the same process is followed, only the brass bush must be large enough to fill the plate nicely and to form the new setting from it. The seat for the jewel should fit well up to it, so as to support it properly, and the bezel should be exactly the size inside to receive the jewel. The walls of the bezel should be cut vertical and quite thin, then burnished down on the jewel. Bouchons can be bought ready made, and containing all sizes of jewels, from any house dealing in watch-maker's materials.

ELECTRIC SECONDARY DIALS OR CLOCKS.

Secretary of Horological Club:

Will you give explanations with cuts, in your paper, how to make secondary dials to work by electricity connecting with regulator, also the battery? Or is there any such published that I could get?

M. L. M.

Mr. Electrode said that secondary dials could be purchased ready made, with the mechanism for moving the hands, connections for the regulator, the battery, etc. It would be useless to attempt to make one himself, unless he was pretty well posted in electricity and magnetism. In that case, it is only necessary to specify the general principles upon which such devices are based. The hands have the usual motion wheels to give the proper relative numbers of revolutions, and the arbor of the minute hand carries a pinion or sort of ratchet wheel, having as many teeth as the number of times it moves or "jumps" in one turn. If it is a "minute jumper," it will have 60 teeth; if a half-minute jumper, it may either have 120 teeth or an extra wheel may be added. In the case of "seconds" and "half-seconds jumpers," two or even three wheels may be required. The last or ratchet wheel has a pawl resting on it, connected to the

armature of an electro-magnet, and is moved back and forth by it. When the current passes through the coils of the magnet, the armature is pulled down to the poles of the magnet. It thereby draws the pawl back one tooth on the ratchet wheel. When the current is broken, the armature is pulled away from the magnet by a spring, and in moving back it pushes the pawl and carries along the ratchet wheel one tooth, thus moving the hands. The armature has stops to properly regulate the extent of its movements, so that the hands will be moved the proper distance each time, after which they remain still till another current is sent from the regulator through the magnet coils. This is all the mechanism there is for the dial—no pendulum, escapement or train, but merely the hands, motion wheels and magnetic device, connected by two wires with the regulator.

At the regulator, a device is used which, at the proper times, complete the electric circuit from one pole of the battery to the regulator, thence to the magnet of the secondary dial, through the magnet coils, and out to the other pole of the battery, which may be put in any convenient place. For a minute jumper, a good arrangement is to put a good-sized ebonite pulley or disk on an arbor which revolves in one minute, with a pawl or lever resting on the edge and sliding easily as the wheel revolves. At one point in this disk is a short slip of platinum, whose exterior is formed to the curve of the disk, so that the pawl will slide upon and over it without friction. The lever is connected to the wire from the battery, and the platinum slip to the wire running to the secondary dial, and the wires, pawl and slip must be carefully *insulated*, so that the current *cannot pass* except when the pawl rests on the slip. This insulation may be done in any convenient way, and the maker may exercise his own ingenuity about it—only being careful to make sure that the insulation is perfect, otherwise a current will pass when it ought not to, and the dial hands will do the same. On the other hand, the connections must be perfect, and the surfaces of the pawl and the platinum slip be kept clean, so that the current will be sure to pass when it should, else the dial hands will not move at all. Should both of these faults exist at once, the secondary dial will be indeed a "fearful and wonderful thing," and a terror to the neighborhood, *i. e.*, to those who try to govern their movements by its erratic hands.

But supposing everything correct, the operation is as follows: The ebonite disk revolves till the pawl rests on the platinum slip, when a current flows from the battery to the pawl, into the slip, through the connecting wire to the electro-magnet, through the coils and back to the battery. This current energizes the magnet, causing it to pull down its soft iron armature, thus drawing back the pawl, which takes into another tooth of the ratchet wheel, and stands ready to push it forward when the armature flies back. As long as the pawl rests on the platinum slip the parts retain these positions. But when, by the revolution of the ebonite disk, the slip is carried from under the pawl, the current is broken, the magnet ceases to hold the armature, which flies back, moves the pawl, and with it the dial hands. This is repeated as often as the platinum strip makes contact with its pawl, which may, of course, be arranged to occur as often as desired. Care must be taken that the parts separate or break contact at the exact instant that the hands ought to move, which can be done by turning the disk on the arbor to the proper point, then securing it there.

As regards the battery, what is known as the Leclanché is the least troublesome to take care of, and will last a year before needing to be replenished, with such a clock. One cell will usually be strong enough, but two or more may be used for the sake of certainty. They should be connected in series, *i. e.*, the zinc of one to the carbon of the other. The carbon of the first is connected to the regulator, and the zinc of the second to the secondary dial magnets, as before stated. Whatever number of cells is used, a magnet of equal electrical resistance should be employed, in order to get the best effects. All of the wires should not only be covered, but so insulated and placed that no current can possibly pass except through the prescribed route. To secure this, they must not lie on bare metal, nor be allowed to sway about and rub the covering off, nor

placed where water or moisture will run upon them. The connections and rubbing parts must be frequently looked after, and should therefore be so arranged that they can be conveniently got at and inspected. In short, "eternal vigilance is the price of success" with an electric clock of any kind, whether secondary or primary.

Gold and Silver—their Elaboration.

(Continued from Page 397.)

THE NEXT work that engages our attention is enameling. The art of covering metallic surfaces with coatings of colored glasses, rendered opaque by suitable additions, is very old. In the museums of antiquities may be seen enameled ornamented articles, the work of which plainly shows that it belongs to an early Byzantine art period. These enameled objects are by far excelled in age by many Chinese works, and it appears that this people, as well as the Japanese, understood the art of enameling several thousand years ago.

XVII.

THE CONDITION OF THE ENAMEL.

Every enamel may more or less be called an easily-fusible glass, rendered opaque by the addition of a very finely pulverized body of white color, not soluble in the glass, and white enamels therefore possess an appearance similar to porcelain.

Glasses have the property of dissolving the oxides of certain metals, whereby these latter impart a certain color to the former. Chromic oxide and copper oxide give it a grass-green color; protoxide of iron, a bottle green; antimony oxide colors yellow; gold purple, red; protoxide of cobalt, blue, etc. In union with the white opaque substance and the specific luster of the glass, these colors produced by the metallic oxides are of a very peculiar appearance, such as can only be produced by enamels.

We give below a condensed synopsis of the production and use of enamel, with regard to its employment in the goldsmith's art; we will, however, state that it lies beyond the province of this series of articles to minutely enter into and examine all the delicate details belonging to this branch. We shall devote a series of articles at some future time simply bearing on this question.

As was stated above, every enamel is a glass. The term "glass," however, is all-embracing; ordinary glasses consist of mixtures of potash and silicate of lime, or silicate of soda and silicate of lime; the former are harder and more difficult of fusion than the latter. By adding to the mass a certain quantity of lead oxide, the glass also fuses with greater facility, and refracts light more strongly; the stars and prisms of glass chandeliers, glass articles of ornament, the glasses of optical instruments, imitation jewelry, etc., are manufactured of lead glass.

In place of one part of the silicic acid, a corresponding amount of boric acid may be taken for the glass; many of the enamels, especially those used for artistic purposes, often contain no silicic acid, but consist of borate of soda and borate of lime; it possesses little cohesion, however; it is best, therefore, to produce a glass for the enameling mass, and especially for the so-called ground, in which silicic and boric acids have been used in equal parts.

For a white body, to impart opacity to the enameling substance, is ordinarily employed tin oxide, either alone or mixed with lead oxide; the larger the amount of tin oxide the greater the covering capacity of the enamel; in other words, thinner layers are sufficient to cover the enamel. To produce this white enamel as uniform as possible in color, it is necessary to remelt it repeatedly, so that the tin oxide is divided entirely equal in the glass substance.

The ordinary process of enameling is as follows: The white ground mass is first melted upon the metal, after which the covering mass is applied. This latter equally consists of a glass, which is transparent, however, and colored by the oxides; wherefore the colored glass is seen upon a pure white ground, by which the colors receive their highest luster. The application of two layers of enamel

may be omitted in many instances, and desired effects are obtained with one. This, for instance, is the case when a very dark colored mass, black, dark brown, dark red, dark blue, etc., is to be produced, and when the enameling is done according to the peculiar process called *deepened enameling*, (*Emaillé Cloisonnée*, Fr., *Grubenschmelz*, Germ.)

It is unconditionally necessary to employ materials of the highest purity in the manufacture of enamels. The entirely white quartz sand often contains only traces of iron combinations, but these are sufficient for producing a greenish color in the making of the ground mass, and this is equally true of the ordinary soda. It is therefore a *sine qua non* for the success of the manufacture to only use materials of the greatest purity; also the coloring oxide must be in this condition, because it would be useless to expect a pure color. Pure cobalt oxide, for instance, colors glasses to an admirable blue, but if it only contains a trace of iron combinations, a pure blue can never be obtained, but only one tinging into greenish.

PREPARING THE GROUND MASS.

The best material to be employed in the manufacture of the ground masses for silicic acid are pieces of colorless quartz (rock crystal), which is red heated, thrown into water to render it brittle by a rapid cooling, and then pulverized. If only white quartz sand can be obtained, it must previously be cleaned. This is done by pouring equal parts of muriatic acid and water over it, and left to stand for several days, after which it is washed from ten to twenty times with water. It should then be tested by a sample melting of the sand with ingredients necessary for the production of the ground mass, and must furnish a pure white mass, without the least tinge into green; this would show that it still contains iron.

The sand may also be cleaned by mixing it with one-fourth its weight of culinary salt, and violently glow-heating it in a graphite crucible. The iron oxide present and the salt, mutually decompose each other by forming iron chloride, which volatilizes, and the soda enters into combination with the silicic acid.

The glow-heated mass may, by mixing with minium, and melting, be at once reduced into a ground mass, which then represents a lead-soda silicic acid glass. There are to be used: Quartz sand, 100 parts; culinary salt, 25 parts, which are glow-heated and melted with 25 parts minium.

The soda (carbonate of soda), used in enamel melting, must also be free from iron. The chalk, equally employed for the purpose, must be pure white; yellow spots betray the presence of iron oxide, and such an agent would be very pernicious.

The white coloring substance in the ground mass, as already said, generally is tin oxide, to which sometimes lead oxide is mixed. The production of the tin oxide and lead oxide is effected in large quantities in such a manner that 2 parts tin and 1 part lead are melted in a very shallow porcelain dish upon glowing coals, and heating it beyond its point of fusion. The metals hereby become coated with a white layer of oxide, which appears to be yellow in heat; this layer is removed to one side with a glass rod, and a new one is formed, which operation is continued until all metal is oxidized. The oxide is then separated, by washing, from all particles of metal that have remained unchanged.

It is better to operate in the following manner: The tin and lead in the porcelain dish, and reduced to small pieces, is poured over with concentrated nitric acid; the metals are violently attacked under development of brown vapors, the lead is dissolved, and the tin converted into a white powder, tin oxide. When the operation is ended—no more brown vapors must evolve upon the addition of nitric acid—the entire mass is slowly evaporated to dryness, and the white pieces of the mass are glow-heated in a crucible; the nitrate of lead hereby decomposes by leaving lead oxide as residue, and a mixture of pure tin oxide and lead oxide is produced. If it is desired to merely produce tin oxide, then the tin is treated with nitric acid, and after the brown vapors have ceased to evolve, it is heated to boiling, the tin oxide powder is washed with water and dried.

A Stroll through a Watch Factory, and the Finishing of Blank Works According to the Swiss Method.

By OTTO BEHREND, OF ST. PETERSBURG, IN *Deutsche Uhrmacher Ztg.*
(Continued from page 400.)

WHEN THE jewel holes of the escapement have been set, and wheel, anchor and table roller polished, the work of the pivoter begins by turning in the different escapement parts. First, the pinions, next, the fork arbors, and finally the balance staffs are turned in, and done in accordance with the quality of the movement, either in a common or a better style.

With current sorts, the workman simply turns the staffs smooth; those of a better class are ground, while the fine qualities are burnished.

The wheel shoulder is first turned on on the pinions, the riveting is next cut under, and the arbor ground or polished. The wheels are next riveted in place with a half round punch, the pinion itself is shortened to its proper height, the face polished, the lower pivot is made first, afterward the upper one, and the wheels are mounted in the plates.

We have previously seen that the escapements may be executed in different manners. We choose for our further remarks that kind by which the fork is finished when all the different parts have been turned in.

The roughly-prepared fork arbors, containing screw threads, are hardened, annealed, and the thread is cut into the forks. The centers are next turned on, and the arbors, which will generally draw a little out of shape when hardened, are straightened. This is a piece of work demanding great attention, since by the least neglect the escapement is placed either too deep or too shallow, and the fork would not stand horizontally in the plate. The arbors are turned in next.

The height of shoulder for the anchor is best measured with the pinion or cylinder gauge, and the lower pivot is turned on accordingly, so that the entire height of the arbor may be determined and finished. By movements with short fork, in which the anchor bridge stands below the balance, whereby the anchor arbor must be very short, the anchor wheel should always be placed as deep as possible into the plate, so that the short piece of arbor above the fork may be prolonged as much as possible, so as to place the fork thereby at the greatest possible distance from the upper bridge. This care is generally omitted by the factory workmen, and the injurious consequences are soon visible. The oil of the jewel hole runs to the fork and causes irregularities by thickening and gumming; occasioning frequently the standing of the watch.

When the fork arbors are finished, they are screwed together with the anchors and forks; and mounted in the plates, in order to see whether the anchors stand at the proper height to the wheels, and to determine the measure for the height of the table roller, which is equally done by the cylinder gauge.

The balance arbors are next in order, for which roughly-made ones are used, hardened, annealed light blue, and the centers are turned on. The collet between balance and table roller is turned next, which is generally made conical. By arbors intended to be polished, the collet is left its original height, in order to grind and polish it in this form, whereby the corners are always a little rounded. The workman has it hereby in his power afterward, when shortening it to its proper height, to have it with nice sharp corners.

The shoulder for the balance is turned on next, and cut under, next that of the collet, ground, turned down to its proper height, polished, and the upper arbor finally finished. All balances being equal, it is immaterial which one is fitted upon the staff. Both parts receive their numbers only after a table roller has been fitted on, and the staff finished for a given movement.

When the upper parts of all the arbors are ready, their lower half parts are taken in hand. The height of the balance and table roller is first determined by the cylinder gauge, whereby we have the entire

height as far as the pivot rounding. The collet is shortened at the time of turning the arbor, which is then ground, and, if necessary, polished, so that the table roller may, by a few slight taps, be driven as far as the collet, against which it must lie firm and flat. The lower pivot is next turned on and polished, the entire height is then measured, and the upper pivot is turned on and finished in accordance therewith. The pivots receive the well-known conical shape, which permits to make them thinner and stronger at the same time than if cylindrical. They must, however, so far as they enter into the jewel hole, be unconditionally cylindrical, and neither be too long nor too short.

Only the riveting on of the balance remains, which is done with a well-polished, half-round punch; the mounting of the table rollers finishes the work of the pivoter.

Let us examine the grinding and polishing of the arbors, staffs and shoulders somewhat closely.

This is done with articles, the exact size of which is immaterial, quickest and best in the depthing tool and turning lathe, by means of the following contrivance, mounted in place of the T-rest. Its advantages consist in: 1. That the grinding wheel stands free, and thereby any desired size and form may be placed in; 2. That the same, no matter how small, can always be brought into rectangular contact with the article to be treated, without being hindered by the frame; and lastly, 3. The rapid mounting of the arrangement.

We would mention at point 2 that very small wheels, of from 2 to 3 mm. diameter, are used for polishing the sunk, half-round hollows of mainspring arbors (around the square), table rollers, etc., whereby the contrivance is mounted in such a manner that the axis of the polishing wheel stands at right angles to that of the article under treatment.

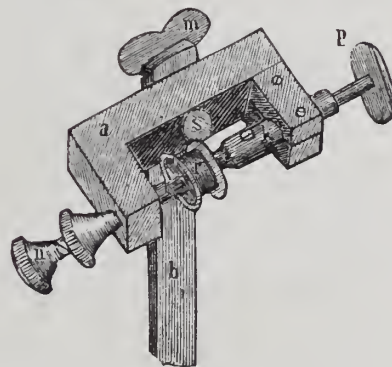

FIG. 1.

The screw is square at the place fitting into pin *b*, as well as the corresponding hole, whereby it is prevented from turning. The

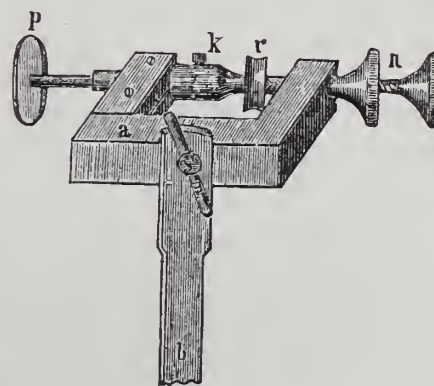

FIG. 2.

contrivance effects that the polishing wheel may be brought into any desired position, even if the lathe centers do not center from above to below, while the turning in the hole of the T-rest slide regulates the sideward position.

Screw *w* with its regulating nut may also be left out, and a smooth pin (point with centers) be made instead. If a wound spring is then placed

upon the spindle, which presses it backward, a to-and-fro motion by a pressure upon the center point may be obtained during work. Fig. 3 shows wheels for polishing around pinions, spring arbors, table rollers, etc., which in size must be suited to the piece, and placed into the spindle, are retained by screw *k*, as can be seen in figs. 1 and 2. The wheel is marked *p*. Roller *r* is set into motion with a drill bow.

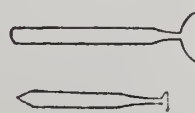

FIG. 3.

upon the spindle, which presses it backward, a to-and-fro motion by a pressure upon the center point may be obtained during work.

This contrivance is used to advantage by conical arbors and beveled shoulders with the same kind of faces, while the depthing tool is better for cylindrical articles and rectangular shoulders.

With this work a handsome black polish, entirely free of flaws, is obtained only when the motions of the wheel, as well as that of the article to be polished, are backward and forward, and at the same time to and fro, that is, the article or the wheel must move to and fro in the direction of its axis, and its revolution must not occur in one direction. The fly wheel, therefore, cannot be employed for such work; and we see in this instance that the old drill bow cannot entirely be dispensed with. The spring of the depthing tool is to be weakened so that the polishing wheel is not pressed unduly hard against the object.

For polishing articles, however, which must be of very exact dimensions, for instance, the balance staff at the part upon which the table roller is to fit with great exactness, neither the one nor the other polishing contrivance is suitable, since the operator has no means of knowing how much has been ground off from the article. Beside this, a frequent taking out and replacing is necessary, and after all it may happen that the staff becomes too thin, in spite of care. It is safest and best to perform this work in the turning lathe with a grinding file either of soft steel or composition, and using the drill bow, although the actual grinding at first may be performed with the flywheel.

We have seen that the pivoteur has finished his labor herewith, and the box is returned to the escapement maker in order to finish the forks and give the last touch to the escapement. He first corrects the shape of the forks, and fits the notch to coincide with the ruby pin. He next screws anchor and fork upon the arbors, and mounts the movements from center wheel to anchor, so as to examine the escapement. The anchors are turned upon their staff in such a manner that the fork, at the drop of each tooth, stands at the same distance from the center line upon both sides. If the escapement is found to stand too deep or shallow, the hole in the anchor must, by means of a thin wire fastened in the saw bow, and pulverized oil stone, be ground out sufficiently, after which the foot pin holes are drilled and the foot pins made. The draw of the wheel upon the anchor is to be examined at the same time. If found too strong, the escapement is placed more shallow, and deeper in the contrary case.

The spaces for the fork's motion are next widened and the banking pins placed; the exact length of the fork and prongs determined, the shake toward the table roller, as well as the entrance and shake of the ruby pin in the fork, is tested and regulated. A half-round or oval hole for inspecting is very appropriate for the purpose.

(To be Continued.)

Sight.

WHAT THE OPTICIAN SHOULD KNOW ABOUT OPTICS.

BY C. A. BUCKLIN, M. D.

Continued from Page 372.

OUR CORRESPONDENCE upon the subjects we have considered in previous numbers has been quite extensive. I am pleased by the intelligent inquiries I am receiving, that our effort to assist the opticians is duly appreciated. All inquiries will, in the course of time, receive attention. Should our explanations fail to make a subject clear, write again and ask definitely what you wish to know, and we will endeavor to supply the information.

The following correspondence from Wilson, Kansas, is very practical in its nature. We will attempt to furnish Mr. Dollenmayer with cylindrical lenses through which he can see, without ever seeing the gentleman. This is something which has never before been attempted and cannot succeed in every case. I would, however, always go to a good expert if possible, and save much trouble.

To the Editor of the Jewelers' Circular:

Please excuse this long communication, but I wish to know all about my case. When quite a boy, I noticed in going along the streets that my companions could read signs quite a long distance before I could see any letter on them. I naturally concluded that I was near-sighted, but when I became older and read concerning spectacles and the eye, I got hold of Jas. W. Queen's Philadelphia catalogue of spectacles and eye apparatus, and found that there was such a thing as astigmatism, but did not comprehend. I bought a pair of near-sight glasses; they did not enable me to read signs at a distance as my companions could do. I was in a quandary what to do. So I studied about the eye and the correction of vision by spectacles, and bought Snellen's test types on card, also Pray's astigmatic card. Then I found out what was the matter. When I looked at Pray's card I could see the N, W, P, D, V, clearer than the others, the N being the blackest. In the June number of THE CIRCULAR, the horizontal line looks the blackest, and each one more vertical gets thinner, the vertical is the faintest. I can read the smallest test type at arm's length, or nearly so. I have no opportunity here to have my eyes examined by an oculist, but am desirous to see better for distance. Can you do anything for me by advice, counsel or otherwise? Is it possible for you to make me a pair, or have made, of eye-glasses, or rather lenses, that will aid me? If so, let me know, also the cost, and let me know what kind of lenses I need. Yours, E. Y. DOLLENMAYER.

Any optician wishing to inquire about a person's vision, to whom the radiating lines, (June number) do not appear equally dark, or who has an obscure visual defect, should answer the following questions:

1. Without glasses, what is the number of the smallest line of "black letters" given in June number, that you can read at twenty feet with your right eye, with your left eye, with both eyes?

If you cannot read any of them, what is the greatest number of feet at which you can read the line XX (June number) with the right eye, left eye, both eyes?

2. At twenty feet what is the strongest convex lens through which you can read XX?

3. If convex lenses make vision at a distance worse, do concave lenses improve vision? What is the number of the weakest concave lens which improves vision the most in the right eye, the left eye, and in both eyes? What is the number of the finest line of block letters you can read at twenty feet with glasses?

4. Without glasses, do the radiating* lines at twenty feet all look equally dark, or do they all look equally dark at the greatest distance you can see them?

Which line is the blackest with the right eye? which is the blackest with the left? and which line is the blackest with both eyes?

5. Do the best glasses you can obtain for seeing the block letters at twenty feet, change the appearance of the radiating lines,* and if so, how, and what is the number of the glass?

To Mr. D. the horizontal lines of our disk appear the blackest. He does not tell us how much his near-sighted spectacles improve his distant vision as measured by our test letters. Neither does he tell us how the lines of the disk look through his near-sighted glasses. This he must tell us before we can figure on a pair of lenses to correct his astigmatism.

If there is 1.5 glass which decidedly improves his distant vision, and the horizontal lines look the blackest, he probably has an oval eye or cornea, with the flattest curve in the horizontal meridian. If this is the case, look at the radiating lines at the greatest distance you can see them. If the horizontal lines look the blackest, begin by trying weak convex glasses, and gradually increase their strength till the vertical lines not only become blacker than the horizontal lines, but till it becomes just as black as the horizontal lines were, and the horizontal lines become just as indistinct as the vertical line was. The number of this lens will just about represent the strength of the cylindrical correction required, the axis of which will be at right

* See June number.

angles to the blackest line seen on the astigmatic disk. There may be other visual defects, as near-sightedness combined with the astigmatism. Therefore if *concave* or *convex* lenses enable one to improve his distant vision to a measurable extent, as measured by our test letters,* he should wear these lenses when experimenting with the radiating lines of the astigmatic disk.

Should *convex* glasses not change the position of the dark lines from a horizontal to a vertical direction, or the darkest line to a position at right angles to what was the darkest line, hyperopic (far-sighted) astigmatism is not present.

You should next try concave lenses, and if a lens is found which changes the dark line from *vertical* to horizontal, myopic (near-sighted) astigmatism exists; or should a concave lens change the darkest line from any position on the disk to a position at right angles to it, *myopic astigmatism* is present.

In hyperopic astigmatism the horizontal lines are usually the dark ones. In myopic astigmatism the vertical lines are usually the dark ones; deviations from this rule are, however, frequent. If we can fit Mr. D. with cylindrical glasses so that he can see at a distance, by simply corresponding, we will have achieved a practical scientific victory which never before has been supposed possible. This effort, if successful, will open the way for many persons residing in places too remote from trained oculists to obtain advice, and who are now suffering from obscure visual defects, to obtain invaluable assistance. We hope Mr. D. will carefully study the questions asked and experiment on the suggestions given, and write us a detailed account of the results he obtains.

The difficulties which Mr. B. meets, as given in his communication below, are undoubtedly frequently encountered by many opticians. We will therefore discuss these enquiries.

To the Editor of the Jewelers' Circular:

During the past few months I have read with interest the articles on optics in your valuable journal, and as a difficulty in reference to the same matter has occurred to us in our trade, I thought you could help us out. A customer requires glasses. Having no bi-concave weak enough to suit (he is short-sighted), I combined a pair of No. 22 *bi-concave* and a pair of No. 32 *bi-convex*. Have tried to figure what number and what shape glasses will answer instead. These used together suit perfectly, and if you can tell me what is necessary you will confer a favor. Will you kindly tell me how to solve a problem of this kind. The want of a *starting point from which to compute strength of concave* glasses, is what bothers me.

Yours respectfully,

J. BRITTON.

To determine what the trouble is with Mr. B.'s customer, it is necessary to know the age, sex, previous occupation and how the person sees at present. What is the *greatest* distance at which the last line of block* letters can be read? Is it more or less than twenty feet? At the greatest distance they can be seen do the radiating lines of the June number all appear equally black? If not, which of the lines appear blackest to the patient?

With your combination of glasses, or any other glasses, *can you convince yourself* that customer can read the block* letters any further away than without glasses? If so, tell how far away he can read them with and without glasses. Try each eye separately; does person see better or worse when he reads with both eyes, or with one eye covered? How long since trouble with eye was first noticed? I suspect slight myopic astigmatism.

If any of the lines in the radiating disk look decidedly blacker than the others, see if convex or concave glasses at any distance will make the line at right angles to this dark line become the blackest, and what is the number of the lens required to make this line exactly as black as the first line was when seen without glasses?

Please carefully experiment and answer my enquiries as fully as possible, and I will do all I can for you.

To figure the strength of various combinations of lenses, two systems are in use. The old or inch system, the new or metric system. The former is in general use by opticians in America. The latter system is the one most used by professional oculists. Without going into the merits of the case, I consider the old system the best. To estimate the strength of a combination of lenses which are all concave, you simply add their *refractive indices* (not their *focal distances*) and the result is the strength of the concave lens equal to the combination. If the lenses are all convex, add their refractive indices, and the result represents the strength of the convex lens which is equal to the combination. If the combination consists of two lenses placed close together, we ignore the factor of distance. Where one is convex and the other concave, we subtract their refractive indices, and the remainder tells the strength of the lens, the quality of which is the same as the strongest lens we had in the combination. Thus, if the strong lens was a convex lens, the remainder would express the convex strength of the combination. If the stronger lens was concave, the reverse would be true.

The strength of a combination of lenses is determined by adding the refractive indices of lenses of like qualities, and subtracting the refractive indices of lenses of unlike quality.

The numbers of the old system all represent the focal distance of the lens. Its refractive index is expressed by a fraction, the numerator of which is always one, and the denominator is always the focal distance of the lens.

Mr. B. combined a bi-concave lens No. 22, with bi convex No. 32. The refractive index of concave No. 22 is $-\frac{1}{2}$. The refractive index of convex No. 32 is $+\frac{1}{3}$. Therefore, $\frac{1}{2} - \frac{1}{3} = \frac{1}{6}$ the number of the concave lens required is No. 70. The new system has only the refractive index given and the focal distance of the lens is not given, we have, therefore, only to add or subtract the numbers as given, to obtain the strength or refractive index of a combination of lenses. We, however, have no idea of focal distances.

The unit of measure is a lens of one meter focal distance, 39 inches and a fraction; this is called a dioptic. The opticians, however, did not change their grinding shells. They called their old lens No. 36 one dioptic; two of them together, two dioptics, or $\frac{1}{18}$. The interval between them is expressed in fractions of a dioptic. I advise opticians to stick to the old system; it has more good things about it and fewer faults than the new system. A table comparing the numbers of the old and new systems will be found in a previous number of THE CIRCULAR.

The distance from a convex lens to a point where it will bring rays of light from the sun to a sharp focus, is the focal distance or number of a convex lens. If artificial light is used, the light must be more than twenty feet away from the lens. There is no such practical way of determining the strength of a concave lens. If a lens is held at twelve inches from our eye, and a distant object observed through it, when the lens is moved, if it is convex, the object observed will always move in a direction opposite to the direction we move the lens. If it be a concave lens, the object will move in the same direction as we move the lens. Therefore, having a concave lens which makes objects dance in the direction it is moved, it is only necessary to place against this lens a convex lens which exactly neutralizes this tendency of the observed object to dance about, and the number of the convex lens will also be the number of the concave lens. If Mr. B. will move his combination of $+\frac{1}{3}$ and $-\frac{1}{2}$ while observing a small distant object through it, he will find that the observed object always moves in the same direction he moves his hand, and that a convex lens of seventy or seventy-two inch focus will just about neutralize these movements.

The quickest way to find the strength of a concave glass is to find the convex glass which neutralizes the movements of distant objects when observed through the lens held at twelve inches distance. We will be happy to answer any further inquiries upon this or any other subject relating to optics.

(To be Continued.)

* See June number.

Workshop Notes.

RUBY PIN.—If it is necessary to tighten a ruby pin, set it in asphaltum varnish. It will become hard in a few minutes, and be much firmer and better than gum shellac, as generally used.

TEMPERING BRASS.—Brass is rendered hard by hammering or rolling; therefore, when you make a thing of brass necessary to be tempered, you must prepare the material before shaping the article. Temper may be drawn from brass by heating it to a cherry red, and then simply plunging it into water, the same as though you were going to temper steel.

POTATO CELLULOID.—According to a Vienna journal, a substance may be produced from potatoes possessing the properties of celluloid. For this purpose the peeled potatoes are boiled for 36 hours in a fluid consisting of 8 parts sulphuric acid and 100 parts water, then dried between blotting paper and relieved of the superfluous water by pressing. Pipe bowls are at present made therefrom in France that can barely be distinguished from real meerschaum, and billiard balls are likewise made from it by strongly pressing.

REPAIRING CYLINDER WATCHES.—It frequently happens that the cylinder edges are worn off, and it does not pay to put in a new cylinder; the watch may, nevertheless, be put into keeping a good rate by altering the escapement. Look at the cylinder and see if there is room either above or below the old wears to shift the action of the wheel. If the wheel holes are of brass, make one a little deeper, and put a shallower one on the other side—this may perhaps be sufficient. This must be done according as you want your wheel up or down. If the holes are stone, shift your wheel on the pinion by a new collet, or turning away more of the old one, as the case may require. If you raise your wheel, see that it works free of plate and top of cylinder, and that the web of wheel clears the top of passage. This last fault may be altered by polishing the passage a little wider, if the rub is slight. If shifted downward, see to freedom at the bottom of the cylinder, etc.

CHAIN RUNNING OFF FUSEE.—In the first place, you must look and ascertain the cause of the difficulty. If it results from the chain being too large, the only remedy is a new chain. If not too large, and yet it runs off without any apparent cause, change it end for end—that will generally make it go all right. In cases where the channel in the fusee has been damaged and is rough, you will be under the necessity of dressing it over with a file of the proper size and shape. Sometimes you will find the chain naturally inclined to work away from the body of the fusee. The best way to remedy a difficulty of this kind is to file off a very little from the outer lower edge of the chain for its entire length; this, as you can see, will incline to work it on, instead of off. Some workmen, when they have a bad case, and a common watch, change the standing of the fusee so as to cause the winding end of its arbor to incline a little from the barrel. This, of course, cannot do otherwise than make the chain run to its place.

ESSENCES FOR CLEANING WATCHES.—Essences for cleaning watches are rapidly coming into custom. They are to be obtained at many of the material dealers and at all drug stores. The object is immersed and left in them for a few minutes, to permit all adhering matter to dissolve; not too long, however, since several qualities are apt to leave stains. The piece is to be dried on removal, and finish by passing a fine brush over that has been charged with chalk and subsequently rubbed on a hard crust of bone. This will produce a brilliant surface on either gilding or brass. The following composition, the ingredients of which may be obtained in a drug store, has been highly recommended: 90 weight parts of refined petroleum and 25 parts of sulphuric ether. The object is immersed for several minutes, in fact they may remain for a longer period without danger, and on removal from the bath are found to be clean and bright. It must not be forgotten that many of these essences are liable to ignite with the mere proximity of a lighted lamp.

COLORING COPPER.—To produce a dark-browened color upon copper, take the white of an egg, beat it into froth, add a little boiled or rain water, and add to this mixture *caput mortuum* (red oxide of iron) color; rub them well together in a mortar, and sufficiently thick until the color covers, and may be applied. The copper article is to be pickled and simply washed; no sand must be used, else the color adheres badly. The latter is next applied with a brush until it covers the surface; it is then dried by fire, the article is gently rubbed with a soft rag and *caput mortuum* powder, and finally hammered with a hammer with polished face.

WATCHES LOSING TIME.—Should a watch lose time from the action of the balance spring, pin the latter into the stud, so that that part, the part of the eye immediately emerging from the collet, and the center of the collet, are in a line; then you will have the spring pinned in, in equal terms, as it is called by those who are versed in the higher branches of springing. Bring the watch to time by adding to or taking from the balance, and poise it; try the watch with the 12 up for two hours, then with the 6 up for two hours, then lying down for the same time; the trials here described will be sufficient if the watch has seconds; keep the curb pins close, so as to allow the spring only a little play; the vibration of the balance should be $1\frac{3}{4}$ turns, or $1\frac{1}{2}$ lying.

HOW TO REGULATE A WATCH QUICKLY.—The following is a practical method for regulating a watch in a few minutes, also to put in a new balance spring, of the right size and regulated perfectly, in a watch without running it: First ascertain how many vibrations the watch beats in one minute, by counting every other vibration, and comparing that time with a well-known watch or regulator. In general, Swiss watches beat 18,000 in one hour, viz., 300 in one minute. American watches also, either 18,000 or 16,200, or 270 beats per minute, and the English lever 14,400, or 240 per minute. If there is any doubt, it is better to count up leaves and teeth and ascertain the right number, but cases that watches beat odd numbers are scarce. Having ascertained the right number, examine the balance carefully for one or two minutes, counting every vibration going from right to left, and in the meantime examine the regulator or clock, to see when one minute is up. If the watch is well regulated, the number of vibrations must be exactly half of the regular first number, viz., 150, 135, or 120, as every other vibration has been recorded to facilitate the observation. If not so, move the regulator right or left until a perfect coincidence comes. To pick up a new balance spring after having recorded the right number of beats—either by the old spring or by the number of the train—lay first the spring with its center well in the center of the cock jewel, and having ascertained where the coil will enter between the curb pins of the regulator, note the place. Stick to the pivot of the balance a small round piece of beeswax; then stick it to the center of the spring, so as to establish a temporary but firm connection of the two pieces, and having pinched with the tweezers the balance spring indicated by the regulator pins, cause it to vibrate gently; then count the vibrations for one minute, and when you have a spring that will produce nearly the required number of beats, pin it to the collet and cause it again to vibrate, moving the tweezers backward or forward until the right number of beats is produced; with another pair of tweezers pinch the balance spring about one-eighth of an inch back of the regulating point, so as to counterbalance the gain produced by the regulator pins, and bend the wire slightly, which is the place where the hair spring must be pinned to the stud. Having then trued up the spring, proceed to put the regulator to the right place, by using the way indicated in the beginning of this article, and the work is done. Success is certain when the operation has been carefully performed. The balance must be made to vibrate on some hard and well polished substance, so as to keep up the vibration to about the standard of regular running. A little practice will soon enable the watchmaker to change a balance spring very quickly, and without any trouble whatever.

Trade Gossip.

Large fans are again in favor.

G. Bynner will travel this year for Freeman & Co.

Round and oval shaped brooches are again coming into fashion.

A large number of western jobbers are in town looking for novelties.

Moses Kahn, of L. & M. Kahn, sailed for Europe in the *Arizona* January 9th.

M. S. Smith & Co., of Detroit, will occupy their new store early in September.

C. E. Farnsworth & Co., will succeed to the business of the late John T. Gold.

G. B. Osborne has left Taylor Bros., and will this year travel for Shaffer & Douglass.

Bracelets of various designs and those with mountings in precious stones are fashionable.

P. G. Mathies' jewelry store at McArthur, Ohio, was destroyed by fire on the night of the 17th ult.

Keller & Untaemeyer have leased the second floor of No. 9 Maiden Lane, and will occupy it early in February.

D. V. P. Cadmus, formerly with A. Bernhardt & Co., will this year represent J. B. Bowden & Co. on the road.

Messrs. Falkenau, Oppenheimer & Co. are now comfortably settled in their new business home, No. 40 Maiden Lane.

J. W. Miller, of the firm of Messrs. Miller Bros., was recently elected president of the Newark Board of Trade.

Leroy W. Fairchild has leased the second floor of No. 18 John street, and will probably occupy it early in February.

O. T. Smith has left the employ of Miller Bros. with a view of embarking in the jewelry business on his own account.

N. Glauber, formerly in the employ of L. Strasburger & Co., has engaged with F. Crandall, maker of diamond mountings, etc.

The firm of Goldsmith, Stern & Co. has been dissolved by mutual consent, and will hereafter be known as Goldsmith & Cohen.

A beautiful coal-scuttle is in hammered metal mounted in elk horns, which form the handles, and surmount it in spiral form.

H. F. Barrows & Co. greeted their friends with the coming of the New Year, with a unique and exceedingly handsome calendar.

The firm of Kearney & Swartzchild, of Chicago, has been dissolved by mutual consent. Theodore Kearney continuing the business.

The fashionable design for Crown Derby porcelain is that known as the Indian, in dark rich colors, as purple, dark blue, or crimson.

Walter D. Cable has left the employ of F. I. Marcy & Co. and entered into a business engagement with T. G. Frothingham & Co.

J. Douty, formerly with Kuhn & Doerflinger, has made an engagement with L. Strasburger & Co., and will represent them on the road.

Exquisite pitchers for lemonade, punch, or claret are of English glass, imported to this country, and engraved here by Bohemian artists.

It is becoming usual to decant champagne, and champagne pitchers are of beautifully tinted English glass, richly engraved and embossed.

A vase in Hungarian ware represents a pumpkin in natural size, the vegetable itself being in white and the bloom and leaves in the natural colors.

Charles Glatz has leased desirable quarters in the new Bryant Building, corner Nassau and Liberty Streets, and expects to occupy it about May 1st.

C. W. Cary, an old and well known traveler in the silver and plated ware trade, is now associated with the firm of J. B. & S. M. Knowles, silversmiths.

The store of Ovington Bros., Brooklyn, was destroyed by fire on the morning of the 5th ult., loss estimated at \$200,000, said to be covered by insurance.

Alfred Frank, who has for seven years, in various capacities, been in the employ of L. Herzog & Co., has recently been admitted to membership in the firm.

Constantine Lucius, a small retail jeweler on the 6th avenue, made an assignment for the benefit of his creditors, and strange to say his preferences are given to actual merchandize creditors. Lucius had been in business about 10 years, and claims to have been embarrassed by robbery.

Noah Mitchell, who some time since made an assignment for the benefit of his creditors, offers in settlement thirty-five cents secured and forty cents unsecured.

Joseph Fahys has admitted to membership in his firm Henry F. Cook, a young gentleman who has been associated with him in business for a number of years.

A. L. Desboullion's jewelry store at Savannah, Ga., was entered by burglars on the night of the 17th ult, and robbed of some \$10,000 worth of diamonds and jewelry.

J. Eugene Robert, agent for Longine and Audemars' watches, has introduced a complete line of interchangeable parts and finished material for these makes of watches.

Hon. C. D. Yale, of the firm of Simpson, Hall, Miller & Co., has been elected to the Connecticut State Senate, and is the first Democrat ever elected to that body from his district.

Lamps have never been handsomer than now. Not only are vases of choice porcelain used as the base, but the globes and shades are in richly engraved Austrian glass, with enameled designs.

Frederick C. Tomlinson, dealer in jewelry at No. 14 John street, made an assignment yesterday to William Smith, giving preferences for \$3,862. He is said to own real estate in Brooklyn and Jersey City.

M. Eisenstadt & Co., wholesale jewelers, No. 703 N. Fourth street, St. Louis, have made an assignment for the benefit of their creditors. Their liabilities are said to be \$110,000, and assets \$80,000.

The firm of Schwitter & Martin, makers of watch cases, has dissolved, and is succeeded by Martin & Tissot, who will continue the business. Mr. Schwitter having resumed business relations with Charles Glatz.

Among the recently imported English ware are vases in white porcelain, upon which are raised designs representing flowers, seaweeds, or, in some cases, coral branches upon which tiny shells and mosses are imbedded.

R. & L. Friedlander will open a down town-office at Nos. 65 and 67 Nassau street, where they will keep a full line of watchmaker's and jeweler's materials, etc. Their Bowery store will be continued as a branch establishment.

One of the newest tools for watchmakers, is a watch and clock oiler on the principle of the stylographic pen, which is so constructed as to control the minutest drop of oil. This is the latest fancy of George H. Richards, Jr., of Boston.

Messrs. Ketcham & McDougal have just erected a large factory corner York and Washington streets, Brooklyn, having outgrown their present quarters in Liberty Place. The firm will continue their office however at the old stand.

J. B. Trickey & Co., of Lincoln, Nebraska, one of the most enterprising firms of that State, are doing an extensive jobbing trade in that section of the country. They carry a large line of clocks, watches, jewelry, optical instruments, etc.

The firm of McIntyre, Bedell & Co. is dissolved by mutual consent, Horace Bedell retiring. D. E. Bedell and Chas. McIntyre have formed a co-partnership under the firm name of McIntyre & Bedell, who will continue the business.

H. Moore, traveler for a New York jewelry house, was recently struck with a sand bag while on his way from a skating rink in Chicago. Moore was robbed of his watch and chain, a diamond stud, and a considerable amount of money.

Leopold Stern, of Messrs. Stern Bros. & Co., was married January 2d to Miss Eva Sterne, of Jefferson, Texas. The presents are reported to have been numerous and elegant. The happy pair are now enjoying the sweets of the honeymoon.

N. M. Shepard, an alleged manufacturing jeweler, doing business at 200 Broadway, has made an assignment to Benj. Lumley, giving three preferences for \$5,834, of which \$4,633 is to Abhu M. Shepard, his liabilities are about \$25,000, and assets not stated.

F. D. Whitney & Co.'s factory at North Attleboro, Mass., was destroyed by fire on the morning of the 28th December. Codding Bros., F. G. Webster & Co., and Young & Bennett, who occupied rooms in the same building, also lost heavily by the disaster.

R. M. Tripp, wholesale dealer in jewelry, has again made an assignment, giving 64 preferences aggregating \$15,557, of which the largest were to T. J. Smith & Co., \$3,955; M. Fitzgerald & Co., \$1,206; Capron & Co., \$1,355. The preferences are for merchandise, borrowed money, and notes. Mr. Tripp failed in May last and compromised for about 50 cents on the dollar in notes extending over 12 months, the liabilities being about \$35,000.

M. Grossman, of the Horological School, in Glashatë, Saxony, writes that Sidney C. Smith, formerly in the employ of Robbins & Appleton, at Chicago, is making excellent progress in his studies. He is highly commended by the professor for his intelligence and zeal.

Notwithstanding the slight disappointment of a few who were too sanguine as to the holiday trade, the Boston retailers did a very satisfactory holiday business, and the sales of the year will fully equal those of 1881, leaving them without surplus stock to carry over.

The recent fire in J. B. and S. M. Knowles' establishment in Maiden Lane, caused but a slight inconvenience to the business of that house. They and the Pairpont Manufacturing Company, who occupied the same office, are now filling orders with their usual promptness.

In the reign of Edward I. there were only two clocks in England, one placed in an old tower at Westminster Hall, the other in Canterbury Cathedral; but they were both of foreign workmanship, and it was not until the time of Edward III. that clocks were made in this country.

Courtland E. Hastings, of the firm of Carter, Sloan & Co., having been closely confined to office work for many months, is about to take a trip to California in the interest of the firm. He will call upon the friends of the house *en route*, and renew acquaintance with their numerous patrons.

Plaques of hammered metal are mounted on deep toned velvets, and then framed with narrow beadings of ebonized work. The most popular designs are Moorish or Arabesque. Those who are in the secret of such things assert that Moorish designs are to be universally adopted in decorations.

E. S. Smith and B. H. Knapp, junior members of the firm of Wheeler, Parsons & Hayes, have severed their connection with that house, and have formed a co-partnership for the purpose of conducting a general jobbing jewelry business. They hope to be ready for active business early in March.

John Mount, of the house of Rande, Barmore & Billings, well known on the road, sailed for Europe in the *Bothnia*. Oscar Wilde, the apostle of æstheticism, was his fellow passenger. We trust Mr. Mount will not be corrupted by the dampness of this degenerate representative of an effete nation.

The firm of A. Wallach & Co. has dissolved by mutual consent, and retire from active business. Leopold M. Rosenberger, Max Rosenberger, Samuel Wallach, Nathan Wallach, Sigmund M. Schiele and Louis Schiele have formed a co-partnership under the firm name of A. Wallach's Nephews, and will continue the business of the old firm.

Leon L. Gallet has transferred to his son Julien Gallet, Jr. and his nephew Jules Racine, his interest in the firm of Julien Gallet, of which he was sole proprietor. The firm will hereafter be known as Julien Gallet & Co. Charles Perret who has been interested in the American business of the firm, will continue to be its sole agent in the United States.

E. F. Bowman, of Lancaster, Pa., has admitted to membership in his firm his late employe W. B. Musser. The business will hereafter be conducted under the firm name of Bowman & Musser, who will continue to do a strictly jobbing business. They greet their friends in the trade with a very beautiful and artistic calendar of real worth and convenience.

A patent has been applied for by parties in this city for an improvement in the foil back of imitation diamonds. The purpose of the new method is to impart increased brilliancy to the imitation stone, and, at the same, time do away with the clumsy appearance of the foil. The new idea promises to introduce to the trade a line of improved imitation stones that will become popular.

The latest novelty in jewelry is a little hunchback or Polichinello, in gold or in oxidized silver, to be worn suspended from a bracelet or from the chatelaine. This is the latest *porte bonheur* or charm for good luck, and seems destined to as great popularity as the twigs that were in vogue for so long. The latest bracelet is a mere thread of gold with a single precious stone, preferably a diamond, in it.

At the regular meeting of the New York Jewelers Club, held at their rooms at the Astor House, Tuesday, January 9th, an appropriate set of resolutions, handsomely framed, was presented to Messrs. C. D. Marsh and F. H. Bliss, the Ex-President and Vice-President of the Club. At the same time a poem was read by T. L. Parker, the author, as a companion to the resolutions. The poem showed a good deal of thought and reflected credit upon Mr. Parker. Lack of space only prevents us from printing it in full.

J. B. Gotthelf & Co.'s jewelry store at Vicksburg, Miss., is reported to have been closed by attachment of local creditors, whose claims amount to \$16,452. It is thought the total amount of liabilities, including foreign creditors, when all heard from, will not exceed \$48,000, while the assets will reach \$56,600. It is believed the firm will be able to arrange matters and resume business in a short time.

The birth of the 2,000,000th movement of the American Watch Company of Waltham, occurred last week. The accouchment was attended by all the foremen of the various departments of the factory, the delivery was safely accomplished, and "Mother and Child are doing well," while the paternal relative is enjoying the most robustous health; attending physicians declare that the happy parents are good for at least 2,000,000 more offsprings of the same character.

John Wetherel Bell, of Conowingo, Md., has recently patented in this and European countries an improvement in watch hands, whereby any watch may be made to record the time in two different cities. It consists of two different sets of hands for a watch, one set of the usual formation, the other being almost invisible. The invisible ones are called "travelers," and may be set to keep the time of any city the wearer may choose. This device is especially desirable for traveling men, who can, by its use, keep the time of any two cities, or that of each terminus of their route.

Mr. Henry Ginnel, who has been in active business for forty-two years in this city, has admitted to partnership his son, W. G. Ginnel and his son-in-law, F. R. Simmons. Mr. Ginnel claims to be well acquainted with his son, having known him longer than any other person has, and is satisfied that his daughter was correct in selecting Mr. Simmons for her life partner. The young blood thus infused in the old house will relieve the senior member of much responsibility, but the young men will have to get up early if they hope to excel the elder in activity or to rival his business reputation.

A committee representing the various trades, professions and industries of New York, has been appointed to solicit subscriptions for the purchase of a pedestal on which to place the colossal statue of "Liberty Enlightening the World" which the French Government has presented to the United States. Our government has given the site for it on Bedloe's Island, the pedestal will cost \$250,000, a portion of which has already been subscribed. Mr. Appleton, of the firm of Robbins & Appleton, has been selected to receive subscriptions from the jewelry trade and kindred industries. Robbins & Appleton and Tiffany & Co., open the subscription with \$500 each.

William C. Edge, of the firm of Dorrance, Edge & Co., has recently been granted a patent for inlaid work and the process of making the same. Heretofore the beautiful effects produced by inlaying one metal with another have only been reached at great expenditure of labor and time. Mr. Edge has devised an entirely new process for producing inlaid work, which reduces the cost materially and gives the same beautiful results. His method consists in intimately connecting the metals desired to be used in slices, and then by an embossing process, bringing the lower slices into the plane of the upper one, where they can be worked as desired. Mr. Edge's patent gives him not only the exclusive right to such inlaid work, but also the right to the process of making it. The invention promises to be one of great importance to the trade, as there is no limit to its application.

Two diamonds for ear-drops, each weighing 10 $\frac{3}{16}$ karats, were confided by the firm of Alfred H. Smith & Co., to a diamond broker who did business for them. This broker allowed them to go out of his hands into the possession of Elijah Meyer, taking for them a receipt, by which Meyer bound himself to return them to their owners if he did not find a purchaser for them within a certain time. Meyer passed the gems to Henry Clews, the banker, and made no return on account of their value to Messrs. Smith & Co. That firm then brought a replevin suit against Henry Clews & Co. The case was tried before Judge Lawrence and a jury in the Supreme Court. The testimony for the plaintiffs was that Meyer did not sell the diamonds to Mr. Clews, but gave them to him as collateral security for speculations which Clews & Co. carried on for him. Mr. Alfred H. Smith testified that Meyer confessed this to him in the presence of Mr. Clews and several other persons. On the contrary, Mr. Clews swore that he purchased the diamonds outright, and in this he was corroborated by Meyer. The jury, however, gave a verdict that the plaintiffs were entitled to have the diamonds returned to them or to receive from the defendants the sum of \$1,400 as their value. The broker Meyer is the defendant in another suit in which Messrs. Smith & Co., allege that he has defrauded them of diamonds, and he has been taken into custody on an order of arrest.



VOLUME XIV.

NEW YORK, MARCH, 1883.

No. 2.

THE JEWELERS' CIRCULAR AND HOROLOGICAL REVIEW

*The recognized organ of the Trade, and the official representative of the
Jewelers' League.*

A Monthly Journal devoted to the interests of Watchmakers, Jewelers, Silversmiths, Electro-plate Manufacturers, and those engaged in the kindred branches of art industry.

SUBSCRIPTION:

To All Parts of the United States and Canada,
\$2.00 Per Annum; Postage paid.

To Great Britain, France, Switzerland, Germany, the West Indies, Mexico, the Republics of South America, and Australia, \$3.00 per annum. Postage paid.

All communications should be addressed to D. H. HOPKINSON, 42 Nassau Street, New York. Advertising rates made known on application.

Unnecessary Failures.

REPORTS of failures in the trade are beginning to come in rather more freely than is desirable, and, as usual, there are certain features about many of them that are discreditable to the bankrupts, and, at the same time, reflect little luster upon the business sagacity of those who gave them credit. Speaking of these failures as a whole, we should say that the bankrupts have taken remarkably good care of themselves at the expense of their creditors. In many cases there is evidence of pre-arranged and deliberate fraud; yet it has been perpetrated in such manner that it cannot be reached by the criminal laws. In some instances the bankrupt continued ordering up to the moment of his failure, getting all the goods possible on credit, and spiriting them away in a most mysterious manner. What becomes of the stocks of these insolvents would indeed be a mystery did not their brothers, fathers, sisters, brothers-in-law, etc., figure so prominently in the list of preferred creditors, who are made secure by transfers of stock that should return to the creditors. As there have been no disturbing elements in the financial condition of the country calculated to bring about commercial disasters, and as no other branch of industry is suffering in a similar manner, there must be something inherent in the trade that induces so many failures. The inspiring cause of them is but too apparent, and that is unwarranted and uninquiring credit.

In no other line of business of which we know anything is credit so cheap as in the jewelry trade. It is claimed by some that this is necessarily so; that as jewelry is regarded as a luxury, the manufacturers must embrace every opportunity and take great risks in disposing of it. This is true only so far as the trade itself has encouraged this idea. There is a steady and legitimate demand for the products of the jewelry trade, and this demand can be met with as much safety to the seller as can the demand for any other articles. But it is in the attempt to push sales beyond the legitimate demand that irresponsible men and sharpers are brought into the ranks of

dealers and the list of dishonest bankrupts kept full. Manufacturers and jobbers are so anxious to sell their goods that they trust them out to whoever asks for them, without demanding that evidence of solvency to which they are entitled. There seems to be an excess of modesty among manufacturers and jobbers in this respect; in other lines of business the man who asks credit is required to make a satisfactory exhibit of his financial condition, and some trouble is taken to ascertain that his representations are true, but in the jewelry trade such foresight is not displayed to the extent it should be, and creditors are badly victimized in consequence. There appears to be an almost universal desire to multiply the number of retail dealers throughout the country, under the belief, probably, that the more numerous the dealers the greater the quantity of goods that can be disposed of. An excess of retail dealers has a tendency to excite unhealthy competition, and to embarrass those who expect to pay 100 cents on the dollar. By encouraging excessive competition among dealers, manufacturers and jobbers not only induce irresponsible men to engage in the business, but they thereby injure the prospects of those legitimate dealers who are striving to do a fair and honorable business, and to meet their obligations like fair and honorable men. It is a fair illustration of burning the candle at both ends.

But one of the worst features of the promiscuous credit system lies in the fact that even bankruptcy, with attendant suspicious circumstances, does not suffice to destroy confidence in the insolvent. It is an old saying that a burnt child dreads the fire, but the creditor class in the jewelry trade does not appear to be at all afraid of a bankrupt who has victimized them once, twice or even three times. A dealer fails and comes to New York to settle up; he meets his creditors, presents his statement, and offers fifteen or twenty per cent. in settlement of all claims. There are at first some expressions of virtuous indignation, but in the end, the compromise is made, the debtor is relieved from his obligations and free to go on with his business again. The stock remaining to him has cost him little, and he can afford to undersell his neighbors and demoralize the trade in his locality. Not only has he wiped out his indebtedness, but he finds that so far from his credit being impaired, there is a great rivalry to sell him goods again. In every way he is made to feel that his failure has been an advantage to him. On the ground that a bankrupt who has effected a settlement with his creditors is good for two or three years to come, he is besieged by salesmen who offer him liberal credit, and fairly compel him to buy goods. It is by this course of treatment that bankruptcy is made chronic with some men, and they feel that every time they fail they are conferring a favor upon the manufacturers and jobbers. The losses incurred by reason of this indiscriminate giving of credit make up an important item in the cost of doing business. Bad debts must be charged to profit and loss, and those dealers who pay their debts honorably, dollar for dollar, must make up the loss eventually, for it must necessarily be charged to the price of goods sold. So it comes about that the honest dealers are compelled to contribute indirectly

to maintain illegitimate competition that is ruinous to their business, and that is carried on by unscrupulous adventurers.

The moral to be drawn from the numerous failures of late is that promiscuous credit is responsible for most of the evils in the trade, and that a reform in this respect is greatly needed. It is folly to complain of bankruptcies when the practice in the trade virtually offers a reward for bankruptcy. Until there is more discrimination in the matter of according credit, failures will continue to be frequent, and compromises on the insolvents' own terms the order of the day.

A State Association's Mistake.

A FEW MONTHS ago an organization of retail dealers was perfected in Pennsylvania, the object of which, like that of other state associations, was the protection of the retail trade from certain abuses to which it is subjected. Presuming that it would seek legitimately to obtain the end in view, we advised the dealers of the state to join it, and lend their influence to make it a power in the trade in that state. But the organization has evidently fallen into incompetent hands, for they have recently taken a step that is calculated to bring discredit upon the trade, and to give their opponents an opportunity to work them serious injury. The executive committee sought to obtain a pledge from all the wholesale dealers that they would not sell any goods at retail. Many jobbers readily gave their assent to this, others would not commit themselves positively, but signed an agreement not to sell at retail except at a stipulated percentage above wholesale prices, while three firms refused to enter into any agreement whatever. So far as pledging jobbers not to sell at retail, no objection can be raised; but the executive committee was indiscreet enough to publish the schedule signed by a portion of the jobbers, wherein they bound themselves to sell at retail only at a certain advance above wholesale prices, and this advance was printed by the committee. From this it would appear that retail dealers make a profit over jobbers' prices of from 25 to 100 per cent. It is difficult to say which was the greater blunder, to sign such a document or to publish it. To be sure, the circular was marked "confidential," but it should have been taken for granted that such a document would soon find its way to the public, as it did immediately. Of course, outsiders at once took advantage of this stupid blunder, and used it as an advertisement to help their own trade, by pointing out to the public what immense profits the retail dealers were making, while they (the outsiders) not being in the association, were not bound by its rules, and would be content with a much less profit. Thus a club was put into the hands of the outside dealers to beat out the brains of the regular retailers. A more grievous blunder could scarcely have been made than to sign such an agreement, while its publication, even as a confidential circular, was wholly inexcusable. This blunder has already worked more injury to the retail trade than the association will be ever able to remedy. The executive committee has shown its incapacity to deal intelligently with the questions presented to it, and has ruined the prospects of the state association. Dealers will be extremely wary of joining an organization that is controlled by men who have so little appreciation of their responsibilities.

As a matter of fact, the confidential circular is entirely misleading, as it is so framed as to convey the idea that retail dealers make a profit of from 25 to 100 per cent. on all classes of goods handled by them, which is a gross exaggeration. We presume every dealer in the state of Pennsylvania would rejoice if he could be assured of as much as ten per cent. profit on his sales, and those of them that have netted that amount of profit during the past five years are regarded as the fortunate ones. The advance over wholesale prices named in the circular was in the nature of a restraining clause, to prevent jobbers selling at retail, whereby they stipulated that in any instances where they were tempted to retail goods, they would charge these excessive prices, which are far above those charged by the retailers. The prices named are no indication of retail prices what-

ever, but were made extravagant for the very purpose of driving the retail trade away from the wholesale dealers to the retailers, where the prices would be found to be more reasonable. Wholesale dealers, as a rule, do not desire a retail trade; it is an annoyance and inconvenience to them, and they would far rather see it entirely in the hands of the legitimate retail dealers. Nevertheless there are always to be found a few jobbers who will sell to Tom, Dick or Harry at the same prices they charge the retailers. To break up this practice has been the principal object of the state associations, and in the west, where the matter was handled with a greater degree of intelligence, the movement has been successful in the main. But the Pennsylvanians blundered, and outsiders have not been slow to take advantage of their egregious mistake. Nothing that can be now said will rectify the error; all that can be done is to let the matter die out as soon as possible, trusting that the public will soon forget it. But the members of the association should not lose heart; the object for which they organized demands their co-operation even more now than it did before, and every dealer in the state should lend his influence to make the organization stronger and better. They should come together at the next meeting and consult earnestly and zealously, that measures may be devised to carry out the original objects of their organization, and to overcome the prejudice that has been excited against legitimate retail dealers by the blundering of the present executive committee. Instead of being disheartened by lack of success, the disaster that has been precipitated upon them should nerve them to renewed effort to overcome the abuses from which they suffer. We hope every dealer in the state will join the association, for in union there is strength; with union, harmony and energy they can accomplish all that it is desirable to have done.

Tinkering at the Tariff.

CONGRESSIONAL tinkering with the tariff during the past two months has done more to demoralize the entire business of the country and to produce stagnation than all other influences combined. From an active and prosperous condition of trade, everything has become unsettled and uncertain. Scarcely an industry that has not been threatened in its material interests by this everlasting and impotent Congressional gabble about tariff revision. In some instances it has been proposed to reduce the duties on certain classes of imported goods, thus compelling our industrial classes to compete with the cheap labor of Europe, and in other instances it has been proposed to increase the duties, thus unsettling the enterprise and capital invested in American industries. But whatever the suggestions made, the legitimate and inevitable effect of the agitation is to destroy confidence in the existing condition of things, and to introduce chaos where prosperity and industry flourished before. In our February issue we showed how Congress had proposed to raise the tariff on precious stones from ten to twenty-five per cent. *ad valorem*, and the petition against the change that had been forwarded by all the diamond importers of this city. They represented that such increase would throw the trade in diamonds into the hands of smugglers, and drive legitimate importers, who pay over \$900,000 a year in duties, out of the trade. Since then the Senate has adopted the proposed increase, but subsequently rescinded its action, leaving the duty as it stood. But so many dissensions have sprung up in Congress on the tariff question, that it is not, at this writing, probable that any changes will be made whatever. The indications are that this turmoil and agitation, resulting in business prostration, will have no other conclusion than to permit members of Congress to air their ignorance regarding trade and commerce.

In view of the demoralizing effects already produced upon all branches of commerce by this tariff discussion, we would caution the jewelry trade against being oversanguine regarding the spring business. The retail trade has fallen off considerably, and dealers feel it incumbent upon them to move cautiously as regards the future.

They are afraid to order freely, lest they stock up in excess of the demand, and are in various ways reducing their expenses. This is a wise precaution, and, although a possible present disappointment temporarily, will in the end result beneficially. There is nothing so bad for the trade as an overstocked market; goods become out of style, shop-worn and unsalable, resulting in loss to retailers, jobbers and manufacturers. Wisdom dictates that the signs of the times should be carefully studied at all seasons, and great care exercised to avoid over-production. This is important at this time, when so much uncertainty exists as to the future of Congressional action. Manufacturers especially should use the greatest caution in their productions, so as to neither overstock the dealers nor themselves. While we do not anticipate any prolonged dull season, it is the part of wisdom to be prepared for even a temporary lull. The cause for the present stagnation will disappear with the adjournment of Congress, and, no doubt, there will be a general revival in business, but until such revival makes perceptible manifestation, caution should characterize every transaction. It is far better to have the demand anticipate the supply than that the trade should be over-burdened with goods at a time when little activity is displayed by purchasers.

Labor Agitators.

WE WISH to say a word by way of caution to the workmen in the trade relative to labor agitators. There is a certain class of glib-tongued adventurers going about the country seeking to stir up dissatisfaction in the ranks of working men, and to prejudice them against their employers. A meeting was held in this city recently of the Journeymen Jewelers' Standard Association, and a report in a daily paper says: "Speeches were made by several labor agitators, who told the men that as long as they were not united for mutual protection, they would remain at the mercy of their employers, who cared only about enriching themselves and nothing for their workmen. The speakers advised secret organization." We have not a word to say against trade organizations; on the contrary, we believe in them when they are properly directed and controlled. They tend to develop the workmen intellectually and technically, furnish their social recreation, and are a medium for diffusing throughout the trade useful hints and suggestions. But we do condemn most heartily, in substance and in detail, those professional labor agitators who go about from city to city, and from one trade organization to another, sowing the seeds of discontent and seeking to breed discord and demoralization. These are adventurers who make a living from the hard earnings of the working men, giving nothing in return but vicious counsels; they are not workers in the hive of industry; they have nothing to lose by revolution, but hope to gain everything. Having no fixed employment, they have no obligations to employers, no interests at stake, generally no families to provide for. They cater to the worst passions of men, not to their intelligence, nor do they care for their interests or welfare. Their purpose is to overthrow the existing condition of things and to establish chaos in its place, in the hope that during the upheaval there will be opportunities for them to better themselves. They come before the working men as disinterested patriots, but are in reality but the most selfish of men, seeking only their own advancement and glorification. What the purpose of the recent meeting was we are not informed, but the presumption to be derived from the statement quoted is that the question of wages lies at the bottom of their discussions. This is a subject that no combination should attempt to control. The wages question is one that should be considered between employers and employed, in a dispassionate, calm, fair-minded manner, and when so discussed, it can always be settled satisfactorily. But when agitators and adventurers attempt to lead the workmen, trouble is sure to ensue that invariably results disastrously to the workmen. Employers are human, and susceptible to all the passions and sympathies that other men are. They do not like to be driven or coerced, but can be reasoned with and led much more easily. They give their time,

capital and energy to the prosecution of the business, and are entitled to fair and reasonable profit upon their investment. Too often, however, the only satisfaction they have in conducting the business is derived from the fact that they have kept their men employed, for excessive competition and heavy expenses leave them little or no profit on their production. The question of wages is one that should be adjusted by each workman with his employer. No combination or labor organization has a right to attempt to fix the price of skilled, intelligent labor. To do so is to cheapen excellence, and to elevate mediocrity to a level with superior skill. Every workman of intelligence and possessed of any self-respect should treat as an insult all attempts of trade organizations to fix the price of his labor, and to say that he shall receive no more and no less than the price specified in their tariff. A workman's compensation is dependent upon himself alone; if he is a skilled artisan, of good habits, and inclined to make his employer's interests his interests, he can command the best wages given for the kind of labor he has to sell; if he is the reverse of this, lazy, incompetent, shiftless, no edict of a labor organization can keep him in employment or secure him wages. The tendency of labor combinations on the wages question is to put the lazy and shiftless on an equality with the competent, careful and prudent workmen. No man of self-respect can submit to be dictated to in this manner. His right to earn his living in such a manner as suits him is a prerogative of his manhood, and no one has a right to interfere with him in the prosecution of an honorable calling in an honorable manner. We warn all workmen against the wily tongues of those professional labor agitators, who make a business of stirring up dissensions and discord, who have nothing to lose but everything to gain by any disturbance that unsettles the working men and places them in an attitude of hostility towards their employers. When a question of wages comes up, that should be settled by each individual for himself with his employer.

Unbusinesslike Competition.

THERE IS AN unhealthy competition in the casemaking industry that is making those engaged in it the laughing stock and by-word in other branches of the trade. The most unbusinesslike practices are indulged in, and the business has become about as thoroughly demoralized as it well can be. Case making is an industry that has had a rapid and vigorous growth in this country, corresponding to the growth of the business of making movements. Every movement must have its case, and, as many thousands are made each year, case making has become an independent and distinct branch of the business. Large amounts of money are invested in it, and Yankee ingenuity has been taxed to its utmost to devise improved methods for producing cases quickly, artistically and cheaply. Rapid production has led to active competition, and this has resulted in such an unwarranted cutting of prices that no profit is left to the manufacturers. There is scarcely any article handled by the trade that possesses so much intrinsic value proportionate to its cost as a watch case. It is rich in precious metals and in skilled labor, yet so great has been the competition of late that cases sell for little more than the value of the metal in them, and the labor expended in their manufacture scarcely receives pecuniary recognition. It seems impossible for one manufacturer to name a price for cases so low that another will not undersell him, and as one reduces his prices, all the others follow in a strife to see which can undersell the other. A manufacturer having a large stock on hand, and paper maturing that must be provided for, hopes to dispose of his goods by cutting the price, but before he has disposed of his stock, his competitors have followed suit and prices all along the line have had a tumble. This will last for a few weeks, when someone else makes another cut, and the tumble is repeated by all the others. This is simply foolish, suicidal and wholly unnecessary. Remunerative prices for cases can be obtained quite as readily as those in which there is no profit. All that is necessary is for the manufacturers to come together like sen-

sible business men, talk the matter over intelligently, and agree upon a line of procedure for the future that will prevent the repetition of these demoralizing practices. Let them agree that a reasonable price shall be charged for the labor expended upon a case as well as for the metal contained in it. They should also adopt some plan for selling cases that will ensure a better quality than many that find their way to the public. In some of them there is altogether too much base metal used in the springs and other parts, that go to make up weight, and that is charged for as gold or silver. Let there be a reform in this matter, and the case sold by weight of precious metal with a uniform charge added for making; special ornamentation, engraving, etc., to be charged for according to the amount of labor required to produce it. There is plenty of good sense apparently among the manufacturers of cases except in matters pertaining to the sale of their products, but when they come in competition with each other all their business sagacity seems to forsake them, and their energies are devoted to seeing which can undersell the others. We do not believe in combinations of either labor or capital for the purpose of imposing upon the public or upon any portion of it, but when demoralization has seized upon any industry or branch of trade, we do believe that those interested therein should consult together to ascertain how best to apply the remedy, precisely as a physician is called in to prescribe for the physical ailments with which humanity is afflicted. The unbusinesslike competition among the case makers has gone altogether too far, and we trust there is still good sense enough left among them to take immediate measures to secure a reform in practices from which all are suffering.

MUCH COMPLAINT has been made of late regarding a class of peddlers who are maintained by certain houses. An irresponsible person will, for instance, hire desk room in some office in one of the larger cities, and have a few cards printed announcing himself as a dealer in watchmakers' tools and material, or as a jobber in jewelry. He buys a few goods for cash and peddles them out among the retail dealers. He finally establishes a credit with some firm, and through it forms other acquaintances in the trade, finally secures a good line of goods on credit and then suddenly fails. From first to last these men are an excrescence fastened upon the trade. Instead of being jobbers and entitled to the advantages in buying which manufacturers give to jobbers, they are simply pirates, whose purpose it is to victimize everybody with whom they have dealings. Not intending to pay for their goods, they undersell the jobbers, deceive the retail dealers, and finally defraud the manufacturers. There is very little cause for wasting sympathy on those houses that encourage these irresponsible peddlers when they are victimized, for they have no right to sell to them either for cash or on credit. Something more than a printed card of address is necessary to entitle anyone to recognition as a jobber, but when manufacturers choose to accept such evidence, no one will weep when they are victimized. But they are not the only sufferers, for legitimate jobbers and retail dealers are injured by this unbusinesslike competition. They have the right to protest against every advantage of the trade being given to these irresponsible adventurers to the prejudice of those who have capital, credit and reputation embarked in the business.

RECENTLY an evening paper in this city had an article regarding the diamond trade, in which our leading importers were credited with saying that the trade in diamonds had all gone to pieces, that prices were down, and, in short, that the business was in a bad way, and the importers and dealers demoralized. The next day the same paper contained a denial from the importers of having made such statements. The whole thing was a "bear" article, calculated to deceive the public, injure trade and was totally untrue. Notwithstanding this denial was conspicuously made, an alleged trade paper in the west reprinted the first "bear" article, with all its misrepresentations and misstatements. The publication of such false state-

ments in a paper ostensibly devoted to the interests of the trade, betrays either gross ignorance on the part of its editor of the actual condition of things, or a deliberate determination to do the trade all the injury possible. Fortunately the peculiar character of the trade paper referred to prevented the publication doing any serious injury, but the gross carelessness or evil intention was there all the same. Ignorance of trade matters and purely technical subjects can be excused in the daily press because of the multiplicity of events that crowd upon it, but in a journal deriving its support from the trade and depending on it for its very existence, ignorance regarding its specialty cannot be excused. An old writer says that "a blunder is worse than a crime," and for a trade journal to blunder in a manner calculated to destroy public confidence in the trade should entitle the blunderer to such obsequies as were in old times bestowed upon a suicide.

QUITE a sensation in the daily papers was created recently by a cock-and-bull story put forth by some over-zealous detectives, to the effect that extensive frauds in diamonds were being perpetrated in this city. According to their stories the swindle consisted in putting on the market a lot of off-color stones that had been "painted" to give a blue tint. Had the reporters who gave publicity to this yarn taken the trouble to inquire among the diamond merchants as to its truth or falsity, they would have ascertained that such frauds not only have not been perpetrated, but are impossible. It is true that as a mere curiosity, an off-color diamond has occasionally been stained with aniline dye, by which means a very pretty effect was produced. But the dye is not lasting, is readily discovered, and washes off easily. No attempt has ever been made to palm them off upon the trade, and it could not be successful if attempted, for anyone who ever handled diamonds would detect the coloring at once. It is unfortunate that such unfounded stories are set afloat from time to time, for they serve to unsettle the public mind in regard to the trade, for the general public has little accurate knowledge regarding precious stones. No doubt the detectives were victims of a practical joke, but it is not creditable to their sagacity that they should publish such a *canard*, before inquiring of those who would willingly have given them correct information regarding it.

The Jewelers' League.

THE JEWELERS' CIRCULAR is the *exclusive* official paper of the Jewelers' League, and has been selected for the publication of all matters of interest pertaining thereto. Letters or inquiries pertinent to its business or purposes, and which might interest the trade or inquirers, will herein be answered. Address *Jewelers' League, Box 3,444, P. O., New York*, or the office of THE CIRCULAR.

The new Executive Committee, consisting of Messrs. John D. Lyon, Jos. B. Bowden, James D. Yerrington, Robert A. Johnson, Samuel W. Saxton, Clement B. Bishop, and the President, Vice-Presidents and Secretary, members *ex-officio*, held its appointed session on Friday, February 2, and organized by the election to the Chairmanship of Mr. John D. Lyon; the following named candidates were admitted to membership:

Harry T. Minchew, William A. Thompson, Boston, Mass.; Alexander Hobbs, Milton, Mass.; Edward Entwistle, North Attleboro, Mass.; Henry F. Leland, Worcester, Mass.; Thomas Hall, Providence, R. I.; Frank C. Karelson, Jaques E. Karelson, Charles Schaefer, Otis Anderson, John Q. Stevens, Frank A. Andrews, Louis Credner, Chas. J. Dodson, Beaumont Hyman, W. G. Appleton, Louis Harrison, Alfred B. Whittaker, Asa C. Fellows, August F. Charrot, Edward R. Rich, Louis J. Guerringue, Chas. T. W. Moser, Frank R. Horton, David Brown, Ruben Mason, Jr., Frederick W. Van Berner, Theodore J. F. Lexon, Frederick A. Fisher, Chas. L. Krugler, Jr., Wm. F. Cushman, Frederick J. Knight, Theodore A. Austen, Frank J. Squire, James Y. Peniston, Harry K. Dodd, William Storie, New York City; John G. Fream, Brooklyn, N. Y.; Joseph H. Pahl, West Troy, N. Y.; Wm. S. McDonald,

Schenectady, N. Y.; Carrey N. O. Marsh, Clarence T. Platt, Edward P. Beach, Lewis G. Hagny, Henry G. Lefort, Newark, N. J.; Geo. R. Wheeler, James F. Thomas, Edward Schleicher, Philadelphia, Pa.; Willis A. Dillon, Pittsburg, Pa.; M. Henry Jones, Raleigh, North Carolina; Milton O. Devoss, Greenfield, Ohio; Vincent Fischer, Bertram B. Morse, Chicago, Ill.; Franklin Meyer, Frank Schleininger, Rudolph W. Feine, Newport, Ky.; Wm. F. Irvine, Cresco, Iowa; John O. Sehorn, Athens, Tenn.; Francis W. Little, Jr., Pleasant Hill, Mo.; Joseph H. McCay, Gerard, Kansas; John E. Ketchem, Forrest City, Ark.; Wm. G. Hauenstein, Red Wing, Minn.; Frank L. Fish, Taunton, Mass.; Frederick L. Mix, Albany, N. Y.

The report of the Treasurer showed a balance in the general fund of \$2,983.07, and in the death loss fund, subject to the next death, \$4,453.60; four requests for change of beneficiary were granted. Five lapsed members, showing satisfactory excuse for having lapsed, and paying up their back assessments, were reinstated; three applications were rejected and eight were referred or tabled for further inquiry; 64 new members were accepted (including five from Jeannot & Shiebler and five from Tiffany & Co.), making a total membership at this time of 2,413; no deaths have been reported since the special meeting on November 25.

President Woglom and Robert A. Johnson were appointed delegates to the Union of Mutual Benefit Associations of the State of New York.

It was ordered by the Committee that after April 6, 1883, all applicants for membership shall be examined by the local examining surgeons wherever such have been appointed, as follows:

City.	Name.	Address.
Attleboro, Mass.	Edward Sandford.	Attleboro, Mass.
Baltimore, Md.	W. P. Morgan.	119 W. Monument St.
Boston, Mass.	M. P. Wheeler.	744 Dudley St.
Chicago, Ills.	N. B. Delamater.	125 State St.
	Gilman Smith.	"
Cleveland, O.	E. W. Robertson.	367 Euclid Ave.
Louisville, Ky.	S. H. Garvin.	817 Jefferson St.
Newark, N. J.	R. Staehlin.	333 Washington St.
New Orleans, La.	W. R. Mandeville.	125 Canal St.
N. Attleboro, Mass.	Jas. R. Foster.	North Attleboro, Mass.
Philadelphia, Pa.	B. Trautman.	529 North 4th St.
Pittsburgh, Pa.	S. M. Benham.	Pittsburgh, Pa.
Providence, R. I.	Geo. W. Carr.	Providence, R. I.
St. Louis, Mo.	S. H. Frazer.	St. Louis, Mo.

Dr. Joshua G. Wilbur, of No. 153 Broadway, is still examiner and consulting surgeon for the League on all applicants who reside in, or whose business is in New York City or Brooklyn, N. Y.; the order mentioned does not, however, affect the old rule of examination by one's family physician in places where no surgeon has been appointed.

The members of the League have but a faint idea of the labor involved in the examination of seventy-five applications for membership, as was done at this meeting; the questions and answers both of the applicant and of the surgeon's certificate of health are, every one, read carefully and heard by each member of the Committee present. Applicants would materially assist the Committee if they would but give proper attention to filling out their blanks; and while upon the subject of the work of the Committee and officers, it has been suggested to us that the members, by a little thoughtfulness, could save the officers much unnecessary trouble by making their communications directly to the League, either through the mail or the office, No. 61 Nassau street. Official courtesy forbids the refusal of favors asked, compliance with which many times requires the exercise of considerable good nature and forbearance.

Isaac M. Miller, of the firm of Miller Bros., of this city (the firm are also one of the contributors to the League of their share of the Chicago fire fund), who but recently, at the solicitation of several friends joined the League, has generously executed a paper to the League, making the permanent fund his beneficiary, so that in the lapse of years, the benefits of the League will be increased without a proportionate increase in the cost to the members, thus carrying

out the original benevolent purposes and intents of the founders. The League is meeting the success it deserves; by its careful prudent management it has secured the confidence of the conservative members of the trade, and in no better way can such confidence be shown than by such action as that of the gentleman named.

In January, 1881, two members united in presenting to the permanent fund a fifty-dollar government bond, and that being now supplemented by Mr. Miller's bequest, it appears to be the fulfilment of a prophecy uttered by the present President, when offering amendments at the annual meeting in 1881 to provide for the reception of such gifts; we quote from the official record of that meeting:

"Mr. Woglom then went on to say that the purpose of these motions and amendments was to provide for the reception and care of such gifts or legacies as may be made, from time to time, by living or deceased members. He said there were a great many wealthy members in the League, who would undoubtedly take great pleasure in making the League gifts at their death. It might appear unnecessary to offer such amendments as those submitted by him, inasmuch as no bequests had yet been made, but he thought it was a good idea to provide the cage before getting the bird; the bare fact of having the cage was an invitation for somebody to give the bird."

We hope the good work may continue until the cage contains a flock of birds as graceful as Mr. Miller's bird.

We have had so many inquiries as to "what was done at the annual meeting," that we give a synopsis of the action on the proposed amendments:

I. Section 3, Article VI., was amended to make the Section clearer in its meaning.

II. It was voted to adopt a badge representing the seal of the League.

III. The four Vice-Presidents were made members *ex-officio* of the Executive Committee.

IV. The 2,500 membership limit was removed; the membership is now unlimited in number, but the amount of benefit is limited to \$5,000 as heretofore.

V. The limit of ages between which members are admitted, viz., not over 45 nor under 21, stands the same as heretofore.

There were no other additions nor amendments to the plans of the League other than those named.

The members need not apprehend any increase of cost on account of the removal of the limit of membership, for, as indicated, the payment is limited to \$5,000; the greater the number of members the larger the amount collected at each assessment, but \$5,000 only being paid (when the membership is sufficient to net that amount) for each death, the excess goes toward the next assessment, until the accumulation of these excesses amounts to sufficient to pay a death loss, when an assessment will be consequently omitted. The enlarged membership will not increase the annual cost of membership.

The proceedings at the annual meeting are now being printed, and will be sent to all the members early in this month.

Construction of a Pin Escapement.

"WHAT IS the best construction of a pin escapement?" [Question in *D. Uhrm. Ztg.*]

The question touching the correct execution of a pin anchor escapement is not so easily answered, since there may exist several arrangements all of which can equally be correct. However, I will seek to represent a very good escapement of this kind both by draught and explanations.

Draw a line *Ca*, and upon it mark the center of the wheel *C*. With a given radius, here 30 mm., strike from *C* the effective wheel circle *p*; the centers of all the wheel pins lie upon it. A wheel of 30 pins will generally be the rule, and we will therefore base our remarks upon such a construction. With the aid of a protractor mark from point *a*, in distances of 12°, the centers of several pins. In order to prevent the useless and injurious drop, make the pins

semi-circular in their operative parts. The space between two dividing points of the wheel circle, therefore, must suffice for two radii of the pins and for two pallet thicknesses of the escapement piece; one-fourth is calculated for each of these parts. Next finish the shape of the pins with the radius so found, (one-fourth of the space). In order to find the center of motion of the escapement piece, draw a tangent BM at right angles to Ca . Although the escapement arms may be taken optionally long, still it is better to confine the distance from a to M to one and a half the quantity of

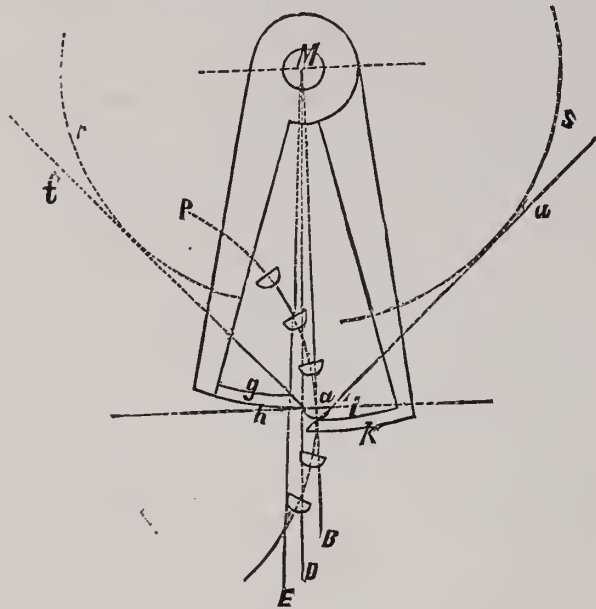

FIG. H.

the operative wheel radius, wherefore, in this instance, to 45 mm., because with longer lever arms the friction upon repose would exert a preponderating influence upon the pendulum oscillations. After all the afore-mentioned one-quarters for the pallet thickness have been marked upon the wheel circle, the drawing of the pallet circles from M is easily done. Next measure upon the arc k , from a , twice the radius of the wheel pins, and draw the lines DE . The position of the lifting planes is determined hereby, the lifting circles r and s also serve for the practical execution. It is not necessary, in consequence of the semi-circular shape of the pins, that the wheel falls more upon repose than sketched. The lifting of the escapement, with this length of lever arms, will amount to 4° .

The following exact proportions for a practical execution might be of service, wherefore it is hereto appended:

Operative wheel radius.....	= 1.0
Diameter of wheel pins.....	= 0.1045
Size of pallets.....	= 0.0522
Radius of repose arc g	= 1.4478
“ “ arc h	= 1.5
“ “ repose arc i	= 1.5523
“ “ arc k	= 1.6045
“ “ lifting circle r , by which the first lifting plane is determined.....	= 1.05
“ “ lifting circle s , by which the second lifting plane is determined.....	= 1.12
Depthing distance from C to M	= 1.803

It will be seen that no allowance has been made upon the sketch for the necessary shake of the escapement. This shake is easily obtained by grinding according to need, a little more than one-half of the entire circle behind from the wheel pins. This can easily be done, since by a complete semi-circular form of the pins, the last part of the lifting rather resembles a drop.—[H. SIEVERT.]

History of the Diamond.

DIAMONDS were first brought to Europe from the East, where the mine of Sumbulpour was the first known, and where the mines of Golconda were discovered in 1584. This district may be termed the realm of diamonds. The mines of Brazil were discovered

in 1728. From these last a diamond weighing 1,680 karats, or 14 ounces, was sent to the Court of Portugal, and was valued by M. Romeo de l'Isle at the extravagant sum of two hundred and twenty-four millions and a-half; by others it was valued at fifty-six millions; its value was next stated to be three millions and a-half, but its true value was £400,000. The diamond called the "mountain of light," which belonged to the King of Cabul, was the most superb gem ever seen; it was of the finest water, and the size of an egg, and was also valued at three millions and a half. The great diamond of the Emperor of Russia weighs 193 karats, or 1 oz. 12 dwts. 4 grs. troy. The Empress Catherine II. offered for it £104,166 13s. 4d., besides an annuity for life to the owner of £1,041, 13s. 4d. which was refused; but it was afterwards sold to Catherine's favorite, Count Orloff, for the first-mentioned sum, without the annuity, and was by him presented to the Empress on her birthday, 1772. It is now on the scepter of Russia. The Pitt diamond weighed 136 karats, and after cutting, 106 karats: it was sold to the King of France for £100,000 in 1720. The Pigot Diamond was sold for 9,500 guineas, in 1802. Diamonds were first found in the Ural Mountains in 1820. The diamond called "the mountain of light," or "koh-i-noor," was found in the mines of Golconda in 1550; in 1849 it was surrendered to the Queen of England; it was accordingly brought over and presented to her, July 3d, 1850. It was shown in the Great Exhibition of 1851. Its original weight was nearly 800 karats, but it was reduced by the unskilfulness of the artist, a Venetian, to 279 karats. A general idea may be formed of its shape and size by conceiving it as the pointed half (rose-cut) of a small hen's egg. The value is scarcely computable, though *two millions sterling* have been mentioned as a justifiable price, if calculated by the scale employed in the trade. This diamond was recut in London, in 1852. A diamond termed "star of the south," was brought from Brazil in 1855, weighing 254½ karats, half of which it lost by cutting.

Mysterious Robbery.

WE ARE informed of a mysterious robbery by our Brazilian exchanges. The diamonds belonging to the Empress of Brazil were stolen last summer, but recovered a few days afterwards in as mysterious a manner as the perpetration of the theft itself. Three persons were arrested and charged with the robbery, while the police spared no efforts in discovering both the guilty parties and the diamonds. After all endeavors had been fruitless, the chief of police received a communication, in which the writer accused himself as being the thief, and mentioned a certain spot where the diamonds were buried, in the vicinity of the house of one of the arrested parties. The police searched the spot, and the diamonds were found intact, buried in two tin boxes. No reasons were given for the restoration. The jewels represented a value of \$400,000. The affair was hushed up, until a press reporter got wind of it, when, of course, the secret was kept more inviolate than ever.

Simple Recipe for Silvering.

THE FOLLOWING is the most expeditious way for silvering metallic articles. Freshly precipitated chloride of silver, after it has been thoroughly washed with hot water, is mixed with equal parts of table salt and cream of tartar, transforming it into a thin paste, by adding water, if necessary. The article to be silvered is first well washed with a hot soda solution and soap, and a stiff brush, in order to remove all dirt, and it is next to be rinsed thoroughly in hot water. A second dry cleaning with fine washed chalk, pumice powder, or quartz powder is to be recommended. After having been well rinsed with cold water, and before drying, it is coated with finely pulverized table salt, so that the article is covered with a thin layer thereof; a little of the silver paste is next rubbed on, whereby the surface to be treated is well and uniformly silver-washed. This treatment is quickly followed by rubbing in a little cream of tartar, which is also to be applied with the same kind of ball, and it is finally washed. The coating is very handsome, clear, and as white as snow.

The Cylinder Escapement.

[BY HERMAN SIEVERT.]

THE ESCAPEMENT is the most important part of the watch, because the good rate of the latter depends upon it. Although the cylinder escapement is the most patient of all since it does its best towards preserving a good rate, frequently in spite of glaring defects, still the able and conscientious watchmaker should nevertheless endeavor to remove them if within his power, when he has a watch with such an escapement in course of repairing, and for this reason he should be thoroughly acquainted with its nature and functions.

The main part of this escapement, the cylinder, is a tube cut open to almost one-half of its circumference, and which carries only a very small part of the lifting planes, the so-called lips. The largest part of the lifting is effected by the inclined plane of the wheel tooth, which alternately pushes along first the one, and then the other cylinder lip. During the entire remainder of the vibrating period of the balance, the tooth lies alternately against the inner or the outer cylinder circumference, and consequently the wheel stands immovable during this time. Together with the Graham escapement, the cylinder escapement therefore pertains to the class of escapements with rubbing repose (dead-beat.)

The single parts of this escapement are called (fig 1): 1. Staffs; 2. Large or upper plug; 3. Small or lower plug; 4. Large tube; 5. Small tube; 6. Large or entering lip; 7. Small or exit lip; 8. Cut; 9. Inner repose; 10. Neck of cylinder.

Those of the wheel are (fig. 2): 1. Tooth plane; 2. Inclined plane or inclination; 3. Shank; 4. Tooth bearer; 5. Tooth point; 6. Tooth heel; 7. Hollow.

In order to make you acquainted with the cylinder escapement, we will endeavor to sketch one, fig. 3. Let us suppose that the wheel is to have 15 teeth, with inclinations of 18°. We first indicate the outer circumference of the wheel by a dotted line, and divide this into 15 equal parts, each at 24°. The dividing points show the places where the tooth wheel is to be, because this decides the dividing of the wheel. In order to find the length of the inclined plane, we first draw line *A* from the wheel center over the heel of the tooth to be drawn, and at a distance of 11° the line *B*, so that 13° still remain for the interval to the next heel. Across the intersecting points of lines *AB*, with the circumference of the wheel, we draw line *D*, and at a distance of 18°, line *E*. We hereby obtain the point for the tooth point where lines *B* and *E* cross each other, and thereby at the same time the length of the plane of inclination. We now transport this length upon each tooth, by a small stroke of the compasses with pencil, starting from the already ascertained tooth heel.

The inclination forms no straight line, but an arc, formed by the diameter of the wheel. We halve the part of line *E* reaching from the heel to the point of the tooth, and from the halving point out we draw at rectangles line *C*. From the wheel out, we measure with the radius of the wheel upon this line, the point from whence the arc for the incline plane is to be struck. It is not necessary, however, to draw a line like *C* for each tooth, but we strike a circle from the wheel center through the previously found point, which intersects all the centers of the inclination arcs. The point of this circle, from which the wheel's radius reaches the heel in question, is to be used as center for the forming of every inclination. When the length of all teeth is ready, the length of which was given above, the remaining part of the wheel is optional, only that the tooth behind at the heel is sufficiently beveled, so that when it stands in the cut it be not in the way of the

cylinder. Again, the hollows must be deep and large enough that the tooth carriers obtain only the breadth requisite to their strength. These carriers must stand back as far as possible to prevent them from striking in the bottom of the cut, by the revolution of the cylinder.

The tooth must, with the center of a straight line, imagined as drawn from the heel to the tooth point, pass through the center of the cylinder. To enable us to draw the different positions of the cylinder, we strike within the wheel circumference a second circle that intersects the center of all straight lines between heel and point of the teeth, and upon which, therefore, the centers of all the sketched positions of the cylinder lie at the same time. The inner diameter of the cylinder is determined by the length of the tooth, the outer by the size of the interval. The sketched positions of the cylinder represent the entire action of the escapement. The first and second positions represent the commencement and end of the lifting at the large cut; the third position shows the end of the vibration, with the tooth lying against the inner repose.

The revolution of the cylinder now begins toward the left, until in the fourth position the lifting on the small passage begins. In the sixth position, the tooth falls upon the outer repose, the finishing of which is indicated by the following and last position. A revolution of the cylinder towards the right now takes place again, until the lifting on the large passage begins anew.

The profile sketch of fig. 3, will specially show that the height of the cut must be three times the thickness of the wheel bottom, so that the possibility of its scraping against the cylinder must not be anticipated.

THE CYLINDER SCAPE WHEEL.

The inclination of the scape wheel teeth were formerly given at 18°, this is the inclination mostly used in common cylinder watches,

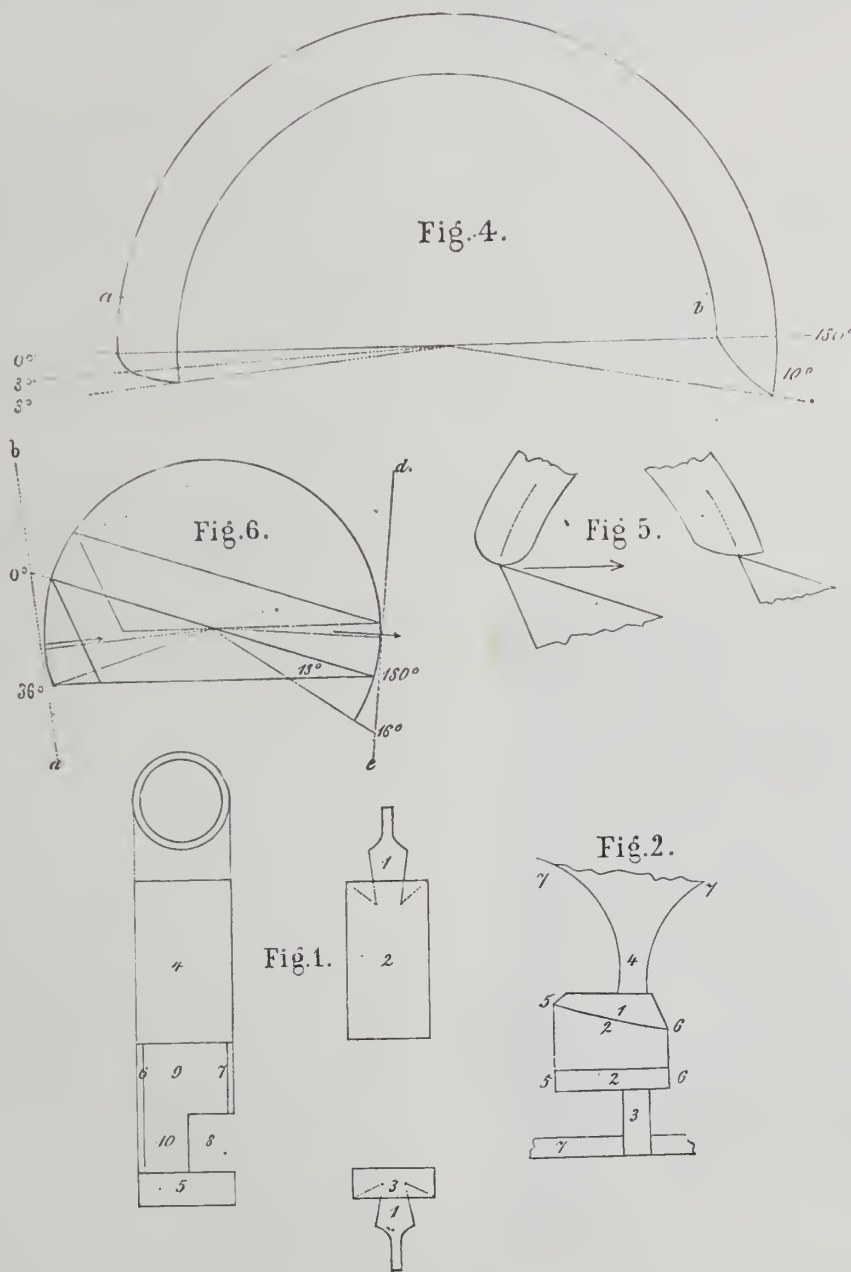

and it will be easily determined if a line prolonged beyond wheel and tooth point will meet the point of the preceding tooth. But the inclination must never be greater than 18° in a gentleman's watch, because a greater one produces more lifting of the cylinder, and the power of the spring no longer suffices to set the watch into motion of its own accord, which is indispensably necessary. Flat watches, which, in consequence of their construction, possess less power of main-spring, demand a smaller inclination; one below 12° , however, again has its various defects. The smaller the inclination, the quicker the wheel has to move during the lifting. Even if the transition from repose to motion is facilitated by a very trifling weight of wheel and the shape of the lips, as we will see further on, a large amount of power will nevertheless be lost by the necessity of a sudden and quick motion. This loss is still increased by the violent striking of the tooth point upon the repose planes, which has a checking effect upon the cylinder motion.

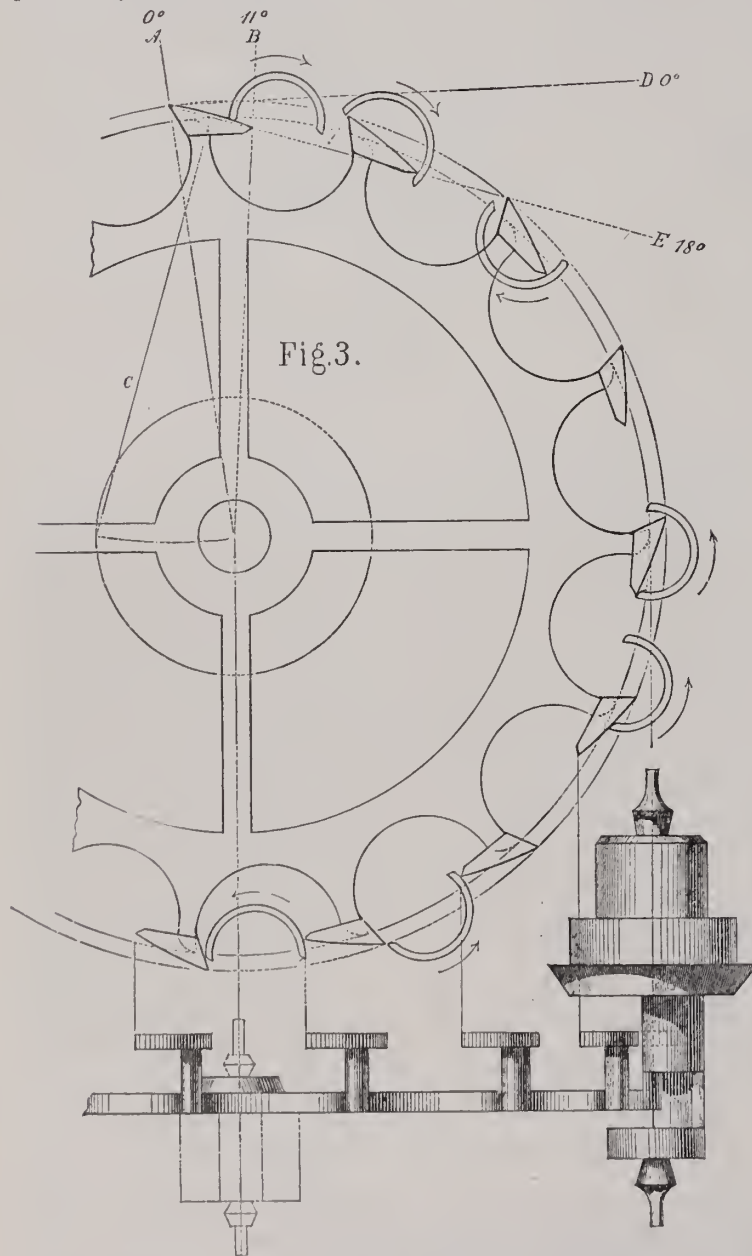

Also the shape of the inclination has for a long time been the object of careful study and practical trials. The reason that by a straight line lifting plane, the lifting is much aggravated toward the end by the increasing tension of the hair spring, and the more unfavorable position of the lips (beyond the tangent,) led to a rounded-off inclination, whereby it becomes more inclined at first, gradually it flattens, and is enabled thereby to accomplish the latter part of the lifting more easily. This form at the same time facilitates the starting of the wheel, since its motion is slower at first, gradually passing into a more accelerated one. Too strong a rounding, however, produces the defect of too strong a drop, which can be noticed by the bending

in of the repose planes at the corresponding places. The mean was adopted finally, an inclination which deviates but little from the straight line, and the arc of which has a radius similar to that of the wheel.

The shank of the wheel-tooth must be a little behind the lifting plane, so that the oil given to the latter cannot be carried by the shank to the bottom of the wheel. The distance of the tooth point from the tooth bearer should be as large as possible, so that the cylinder does not knock against the former, and press the wheel back.

(To be Continued.)

Important Discoveries.

Continued from page 20.

Compass, Mariner's, said to have been known to the Chinese, 1115, B. C., is ascribed to Marco Polo, a Venetian, A. D., 1260, and to Flario Geoja of Amalfa, who introduced the suspension of the needle, 1250. The compass box and hanging compass used by navigators, were invented by William Barlow, in 1608; the measuring compass was invented by Jost Bing, of Hesse, in 1602.

Copper, one of the six primitive metals, said to have been first discovered in Cyprus, and is first mentioned in Ezra viii., 27.

Crown.—An Amalekite brought Saul's crown to David, 1056, B. C., (2 Saul—1.) The first Roman who wore a crown was Tarquin the Elder, 616, B. C.

Cryolite, a Greenland mineral, a fluoride of aluminum and sodium.

Cymbal, the oldest known musical instrument, invented by Cyhele about 1580, B. C.

Dials.—The sun dial of Ahaz, 713, B. C. The first sun dial seen at Rome was placed on the temple of Quirinus, when time was divided into hours, 293, B. C. They were first set up in churches in A. D., 613.

Diamonds were first brought to Europe from the East, where the mines of Sumbulpoor was the first known, and where the mines of Golconda were discovered in 1534, the mines of Brazil were discovered in 1728.

Ear Rings were worn by Jacob's children, 1732, B. C.

Electric Clock invented by Prof. Wheatstone in 1840.

Emeralds are found in the East and Peru. It has been erroneously stated that there were no true Emeralds in Europe before the conquest of Peru, for there is one in the Paris Museum taken from the Mitre of Pope Julius II., who died in 1513.

Enameling was practiced by the Egyptians and Chinese, and was known in England in the time of the Saxons. At Oxford is an enameled jewel, which belonged to Alfred, made in 887.

Encaustic Painting by fire. Painting with burnt wax is said to have been known Praxiteles about 360, B. C. This art was revived by M. Bachelur in 1749.

Engraving on signets is mentioned in Exod. xxviii., 11.; B. C., 1491.

Forks were first used on the continent of Europe in the 13th and 14th century.

Gems.—The Greeks excelled in cutting precious stones, and many ancient specimens remain. The art was revived in Italy in the 15th century. Artificial gems have recently been produced by chemists.

Gold, the purest and most ductile of metals, for which reason it has from the earliest ages, been considered by all nations as the most valuable.

Gold Wire was first made in Italy in 1350.

Goldsmith, Company began about 1327, and incorporated in 1392. The first bankers in England were goldsmiths.

Grain.—Henry III. is said to have ordered a grain of wheat gathered from the middle of the ear to be the original standard of weight. 12 grains to be a pennyweight, 12 pennyweights one ounce, and 12 ounces a pound Troy.

Greenwich Observatory was founded in 1675.
Harp invented by Jubal, 3875, B. C.
Iridium and *Osmium* discovered in 1804.
Jewelry worn by most of the early nations.
Keys and locks are ascribed to Theodore of Samos about 730, B. C.
Longitude determined by Hipparchus at Nice, who fixed the first degree in the Canaries, 162, B. C.
Mosaic work is of Asiatic origin, about 519, B. C.
Needles are said to have been first made in England in the time of Mary I. by a negro from Spain; the invention was lost at his death, and not recovered till 1566.
Nickel, a white, ductile, malleable, magnetic metal, employed in the manufacture of German silver. Cronstedt, in 1751, discovered nickel in the mineral copper nickel.
Niello-work, believed to have been produced by rubbing a mixture of silver, lead, copper, sulphur and borax into engravings on silver, etc., was an art known to the ancients, and practised in the middle ages.
Niobium, a rare metal discovered by Hatchette, in 1801.
Observatories.—The first is said to have been erected on the top of the temple of Belus, at Babylon; on the tomb of Osymandas, in Egypt, was another. The first in authentic history was at Alexandria, about 300, B. C., erected by Ptolemy Soter.
Optics, a science studied by the Greeks, and later by the Arabians, about the 12th century. Burning lenses were known at Athens, 424, B. C. A treatise on optics ascribed to Euclid about 300, B. C. The magnifying power of convex glasses and concave mirrors, and the prismatic colors produced by angular glasses, mentioned by Seneca about 50, A. D. Spectacles are said to have been invented by Salvinis Armatus, of Pisa, about 1300, A. D. Camera obscura, said to have been invented by Baptista Porta, 1560, A. D. Telescopes invented by Leonard Digges, about 1571, A. D. The microscope was invented by Jansen, about 1609, A. D. Laws of refraction discovered by Snellins, about 1624, A. D. Motion and velocity of light discovered by Roemer, 1667, A. D. The velocity of light is said to be 190 millions of miles in sixteen minutes. Structure of the eye explained by Petit, about 1700, A. D.
Odometers or road measurers, are said to have been known in the 15th century, and Pedometers were known in 1799.
Paper is said to have been made in China, 170, B. C.
Pawnbroking, the origin of borrowing money by means of pledges deposited with lenders, is referred to by Perugin in Italy, about 1462.
Pearls.—The formation of pearls have embarrassed ancient and modern naturalists to explain. An ancient pearl was valued by Pliny at \$400,000.
Pendulums.—The isochronous property is said to have been applied to clocks by Galileo about 1650, and by Richard Harris about 1614. George Graham invented the compensating pendulum, 1715. In 1861, Foucault demonstrated the rotation of the earth by the motion of a pendulum.
Perfumery was known 1400, B. C.
Pins were known in 1483.
Plate.—The act laying a stamp duty upon plate was passed in 1784.
Platinum, the heaviest of all metals except osmium. The name originated with the Spaniards. It was known in Europe in 1741.
Polar Clock, an optical apparatus, invented by Wheatstone in 1840, whereby the hour of the day is found by means of the polarization of light.

(To be continued.)

Correct Local Time and How to Obtain it.

IN MY LAST article a correction should be made in the fourth line—for *tubes* read *tides*.

After the solid foundation or rather support for our clock is established, we will resume the details of construction left unfinished in Dec., 1882, number. As hinted at that time, a cheap Yankee-clock movement can be used for the purpose, but it would be much more satisfactory to have a fine train. In this article the complete details of a short pendulum clock will be given, reserving the description of a full seconds pendulum and train running for one year, with improved mercurial compensation for heat and cold, also barometric corrections for atmospheric changes of density for a subsequent article. The train for such a clock ($\frac{1}{2}$ seconds) should consist of 6 wheels and 6 pinions, and is calculated to run 15 days, but should be wound once a week, the extra 8 days being for an accidental neglect in winding. The battery should also be renewed once a week by changing one cup. The first three wheels of the train can be all of one size, and have the same size pinions, also the same number of teeth. Say these wheels are 3 inches (pitch diameter), and have 96 teeth working into 12 leaved pinions, a pinion of 10 or 12 leaves works much nicer than a smaller number of leaves. The actual measure of such wheels and pinions, measuring across the face, and allowing for the portions of the teeth and leaves extending beyond the pitch line, would be as follows:

Wheel diameter (of <i>A B C</i>).....	2.0784
Pinion " (of <i>a b c</i>).....	0.4534

These wheels are shown at *A B C* in the cut, and the 12 leaf-pinions at *a b c*. The wheel *D* has 75 teeth, and $2\frac{1}{2}$ inches pitch diameter, and engages the pinion *d* of 10 leaves.

Real diameter of wheel <i>D</i>	3.5624
Pinion (<i>d</i>).....	0.3957

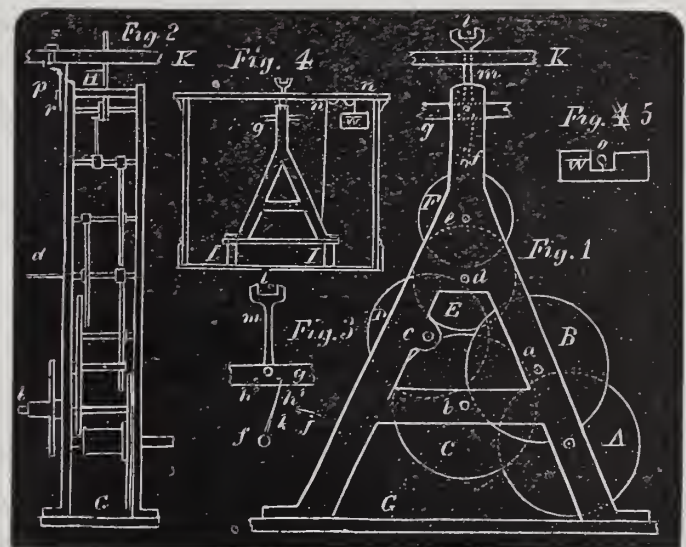

This pinion arbor *d*, carries the second hand on the dial, and the arbor of pinion *b* carries the minute hand, and the usual motion work of hour and minute wheel. The wheels *E F*, are supplementary, and carry the escapement. The reader at this point will see on comparing with December ('82) number, that the writer has varied from the plan shown there of the escapement. This can be explained, as in that article I only gave principles. In the arrangement shown in this cut, the pinion *f*, fig. 1, makes a full revolution every second, or in every other vibration of the pendulum. The wheel *E* (on the same axis as the second hand) has 64 teeth working into a pinion of 8 leaves, shown at *e*, this pinion has a wheel on its arbor of 60 teeth, working into the final pinion of the train with 8 leaves, this pinion is shown at *f*, and on its arbor is a brass collet which has a long light finger which engages two pins on the bar *g*. The action is shown separated at fig. 3, where *k* represents the finger, *g* the tilting bar which breaks and closes the circuit through the magnets. We will suppose this finger is as long as will permit its

point to pass the arbor of the pinion e , and the action of the train tends to carry it in the direction of the arrow j , and the pin l in the lower end of the pendulum strikes the fork m , the finger k is freed from the pin h^1 , and it passes on to the pin h^2 , where it is held until the return of the pin l , on the swing of the next vibration when the pin l strikes the opposite prong of the fork m and k is disengaged from h^2 , and makes nearly a full revolution striking again on h^1 . The action of this part is precisely like the independent escapement of a quarter second watch. The wheels E and F need not be of any exact size, only somewhere about $1\frac{1}{4}$ and 1 inch in diameter, and can be selected from any stock of French clock material, as also the pinions. A word or two of caution; all the wheels of the train beyond C should be poised, and also the pinion f and its finger k , or it may set for the want of power, as the weight for driving the train is quite light. For the benefit of those who wish to cut their own wheels and pinions, I will give the size of wheels E and F , and also the pinions e and f .

Real diameter of wheel E , (64 teeth).....	1.3528 inches.
“ “ “ pinion e , (8 leaves).....	0.1977 “
“ “ “ wheel F , (60 teeth).....	1.0324 “
“ “ “ pinion f , (8 leaves).....	0.1668 “

On the arbor of the wheel A is a spool and ratchet and maintaining power—these of course do not need a description, as they in no way need differ from other clocks. The spool on the arbor of A , if $\frac{1}{2}$ inch in diameter, will give a fall to a weight of a trifle over 9 inches in 15 days, and if the weight weighs 5 pounds it will give ample power. The box for the movement if made of $\frac{1}{2}$ inch stuff, will give 11 inches in the clear. The cord (an A violin string) passes from the pulley on the arbor or wheel A , over the two pulleys shown at nn , fig. 4. The weight, $2\frac{1}{2}$ inches in diameter and $1\frac{1}{2}$ thick, has a recess $1\frac{1}{2}$ inches in diameter, and 1 inch deep as shown at fig. 5, this is to allow the pulley n to go into it and secure greater fall to the weight; the hook to which the cord is attached is shown at o , fig. 5. The pulleys nn are recessed in the top of the case and are $\frac{1}{2}$ an inch in diameter and arranged as shown. The train is put up between to A -shaped plates as shown, and in the cuts, figs 1 and 2 are $\frac{1}{4}$ the real size. The depths to the wheels are best secured by drilling the holes for the arbors and pivots by measurement, than by any clock depthing tool. We know that the pitch diameter of the wheel A is 3 inches, and the pitch diameter of pinion a 0.375; now, by adding the half diameters together, we get the distance apart for the two holes for the pivots of the wheels A and B , *i. e.*, $\frac{1}{2}$ of 3 = 1.5, and the $\frac{1}{2}$ of .375 = .1875, these added give us the distance of 1.687 inches for the two holes. The distance is of course the same for the wheels B and C , and C and D , or rather the pinion of D shown at c . The wheel D , which is $2\frac{1}{2}$ inches pitch diameter, and the pinion d working into it, are 1.3166 inches apart. The wheel E is 1.3 inches pitch diameter and has 64 teeth, and the pinion e , with 8 leaves, is 0.1625, and the pivots of the pinions e and d 0.7276 of an inch apart. The wheel F is 1 inch pitch diameter and has 60 teeth, and the pinion f 0.1333 of an inch pitch diameter, with 8 leaves; distance between the pivot holes for pinions e and f 0.5666 of an inch. The form and arrangement of the train can be seen at figs. 1 and 2. The distances and sizes can all be taken from these cuts (which are $\frac{1}{4}$ size.) The other figures are not in the same proportion, but only to illustrate. The A -shaped plates can be either of cast or heavy sheet brass, if cast brass is used, an allowance of $\frac{1}{16}$ of the entire size must be allowed for shrinkage. The lower ends of the A should terminate in feet which can be screwed to a bed plate shown at G , figs. 1 and 2. At H , fig. 2, is shown a pillar for holding the top of the A plates together, this pillar has a loop for the fork m to work through. The bed plate G has 4 strong pieces of brass shown at I , for securing the movement in the case, and it is best to have these secured by screws passing up through the wooden bottom of the case into these brass pieces as shown at II , fig. 4. At K , fig. 2, is shown a portion of the upper part of the movement case, and a piece which attaches and holds securely the upper end of the A plates in position; k

shows the top of the case and p the piece, s is a screw securing this piece to the top, and p screws the piece to the A plate. This last described piece is important, as it secures the perfect action of the pin in the lower end of the pendulum. The plan of making the electric connections is sufficiently described in the December number already mentioned. A slight friction-spring should be applied to the arbor i of the tilting bar g , the friction should only be very slight. It is hardly necessary to say that this tilting bar g should be perfectly poised.

The Barometer.

THE USE of this word, from *baros*, a weight, and *metron* a measure, is not very appropriate, the common balance being rather a measurer of weight than this instrument, which merely indicates or measures the variations in the pressure of the atmosphere. The barometer is one of the most valuable instruments ever contrived for assisting the philosopher in discovering the laws of the wonderful ocean of air in which we live, and its invention belongs to that highly interesting period in the history of science, “when there were giants in those days,” the seventeenth century, to which pertains the honor of nearly all the profoundest philosophical inventions, *viz.*, the telescope, pendulum, barometer, thermometer, electric machine, air pump, the discovery of the laws of gravitation, etc. History says that about 1643, several well-diggers sank a pump at Florence, for the purpose of raising water from an unusually great depth, when, upon working it, it was found that the water would rise no higher than about thirty-two feet. They consulted Galileo, who returned an unsatisfactory answer.

After his death, his pupil, Torricelli, who had long meditated on the subject, devised the following experiment in the year above mentioned. He took a glass tube about four feet in length, closed at one end, open at the other, and having filled it with mercury, closed the open end with his finger, inserted it, and placed the open end below the surface of mercury contained in a basin. Holding the tube in a vertical position, he withdrew his finger and observed that the mercury sank in the tube to a certain distance, and after a few oscillations, settled at the height of $27\frac{1}{2}$ inches above the surface of the mercury in the basin. On comparing the height of the column of water raised by the pump, he found these heights to be in an inverse ratio of the specific gravities of the water and mercury. Observing also that the column of water and mercury had no communication with the atmosphere at their upper extremities, but indirectly communicated therewith at their lower, he concluded that the two columns were suspended by the same cause, namely, the weight or pressure of the atmosphere. The empty space thus created above the mercury column is still called the Torricellian vacuum.

Many experiments were made with the instrument; the celebrated French mathematician Pascal, among other philosophers, took a great interest in it, and Torricelli's deductions were most brilliantly affirmed. It is impossible in this connection to give even the very outline of the results of these investigations; but if we examine them in detail, we cannot fail to be struck with the grandeur and magnitude of the laws of Nature, discovered by the aid of this instrument.

Endless have been the varieties of shapes given to the barometer, still, the simple contrivance originally invented, and consisting of a tube containing mercury, immersed in a cistern of the same metal, has, after more than two hundred years of experience, been proven to be the best form of apparatus adapted for observing the daily and hourly fluctuations in the changes of the atmosphere. The most important parts of a good barometer are a well-shaped glass tube, from 33 to 34 inches long, of uniform bore, containing mercury; a cistern of the same metal, in which the open end of the tube is immersed, and an accurately divided scale for reading the exact height of the mercurial column.

In the manufacture of a barometer, as well as in its use for observing the air pressure, several very important points must be remembered. First, only the purest mercury must be used for filling. One contaminated with lead or other metals, on the one hand, is not suf-

ficiently mobile for yielding to the slightest pressure, and adheres lazily to the sides of the tube; on the other hand, it impurifies the latter, and forms a sedimentary film on the inner glass side, whereby observations are rendered difficult. Since even with the best of mercury a slight undesirable pellicle of mercury is gradually formed within the space of the bore corresponding to the mean motion of the column, in consequence of which the mercury will finally show a slight adhesion; it is advisable, in the case of fine instruments, to arrest their motion, that is, causing the mercury to enter into the vacuum part, by suitably inclining the instrument.

Beside this, the specific gravity of the baser metals is much less than that of mercury, and their presence would cause the height of the column to be greater than that of an instrument containing pure metal only. Mercury appears to be incapable of retaining either air or moisture, and the air bubbles arising from it when heated or relieved from atmospheric pressure, are simply retained between the mercury and the glass vessel, in consequence of the attraction existing between glass and air. The filling of a barometer tube requires many precautions. When properly filled, it is inverted into a cistern of pure mercury, and when the column sinks to the proper level, its length above the surface of the mercury in the cistern exactly counterbalances the atmospheric pressure, unless, indeed, we take into account the minute quantity of vapor of mercury, which, above the temperature of 60° , rises into the Torricellian vacuum; but this is so slight a cause of deterioration that it may be neglected.

The excellence of a barometer may be tested by the brightness of the mercurial column, and the absence of any flaw, speck or dullness of surface; secondly, by what is called the barometric light, or flashes of electric light in the Torricellian vacuum, produced by the friction of the mercury against the glass, when the column is made to oscillate through an inch or two in the dark; thirdly, by a clicking sound produced by the mercury striking the top of the tube when the column is made to oscillate. If air be present, it will form a cushion at the top, and prevent or greatly modify this click.

The exactness of observations increases with the width of the tube. Narrow ones, the so called capillary tubes, exert an untoward influence—the capillarity—upon the fluids contained within them, according to the substance of the tubes and fluids, and the change of level of this capillarity increases with the narrowness of the bore.

The sectional area of the tube is of no consequence to the height of the column of mercury supported. If the sectional area be equal to one square inch, the column of mercury 30 inches high will be counterbalanced by a column of atmospheric air one inch square, and extending from the surface of mercury in the cup to the top of the atmosphere; and as we know the pressure of air to be about 15 pounds to the square inch, so the column of mercury one inch square in the barometer tube weighs about 15 pounds. If instead of mercury we take 15 pounds of water, and form it into a column one inch square, we get in such a case a height of about $32\frac{1}{2}$ feet. If the sectional area of the tube of the mercurial column be only half an inch, then the column of mercury will still retain the same height, for it is counterbalanced by the same height of atmosphere, only the column of the atmosphere has in this case a base of only half a square inch, instead of an inch. So long, therefore, as the atmosphere presses with the same intensity upon the surface of the mercury in the cup, the column suspended in the tube will be of the same height whatever be its internal diameter.

The range of the barometer in Europe is limited to about $3\frac{1}{2}$ inches, and it is not necessary to commence the scale from the neutral top. The divisions of the scale usually begin at the 27th and are continued to the 30th inch, while instruments intended for measuring the heights of mountains or accompanying balloons, are provided with a scale, the divisions of which begin at the 12th or 15th inch; of late years, the scales of barometers serving for scientific purposes are divided according to the metric system.

If the temperature depended alone upon the pressure of air, then the barometer would be an unfailling prognosticator of the weather;

but heat and moisture are two chief factors of the change of temperature, and the instrument is unable to indicate their participation. It must be remembered in what manner winds are produced, how arising and descending currents of air, by their encounter, effect atmospheric precipitations, as well as storms and hurricanes. Although a descending current of air must necessarily increase the pressure of the atmosphere upon a lower point, and *vice versa*, an arising body of air must ease this pressure and cause the column of mercury to sink, still the upper wind is at times warmer and moister, and again colder. We sometimes meet with the one, sometimes the other, and then again we find ourselves in the region of their comingling, consequently, the most widely-diffusing causes can at times effect uniform indications of the barometer.

But in all these apparent irregularities, diligent observers have finally begun to reduce the seemingly great chaos into order, and to distinguish one great remarkable law. Daily, even hourly, annotations of oscillations have been made, and these, when compared with each other, show the regular return of a maximum and minimum position as well as of the pressure of the air. If the positions of the mercurial column are graphically placed together, or if the rising and falling of the *meniscus* (the convexity of the top of the mercury column) is made to photograph itself upon a moving, suitably-prepared paper, pictures of waves are obtained, the inconstancy of which betrays the great mobility of the aerial ocean.

From this both a daily wave and a yearly maximum and minimum have been deduced. They are not exactly alike for all points of the earth, still they all coincide so far that the barometer reaches its highest position at about 10 o'clock P. M., and its lowest about 4 o'clock A. M. It rises from this, its lowest position, till about 11 o'clock, and descends again until about 4 o'clock P. M., when it attains its second minimum, thence to ascend again until the hour mentioned. The daily wave therefore undulates between two mountains and two valleys. This uniformity is so constant in the tropics, that Humboldt says the time can be ascertained by the height of the mercurial column. The turning points vary somewhat with us, according to the season.

The annual wave attains its greatest height in winter, its lowest in summer. The cause of this may without difficulty be recognized as due to the unequal heating of the air by the sun.

The barometer is principally used as a meteorological instrument. Opticians have attached to certain heights of the barometer varying states of weather, and at different points of the scale the words "rain," "fair," "changeable," are marked, but these established points are very misleading; an eminent European authority says that from the observations of two centuries it has been found that heavy, long-continued rains take place with the mercury at 29.5 inches, or "change;" that rain frequently falls when it stands as high as 30 inches, or "fair;" and more particularly in winter, a fine bright day will succeed a stormy night, the mercury ranging as low as 29 inches, or opposite to "rain." It is not so much the absolute height as the actual rising and falling of the mercury which determines the kind of weather likely to ensue.

A fall of the mercury generally indicates approaching rain, high winds or a thunderstorm; but snow is more frequently preceded by a rise than a fall. With this exception, a rising state of the barometer commonly indicates the approach of fine weather. The lowest depressions occur with winds in the south and southwest, when much rain falls, and frequently short and severe gales blow from these points. A northwest wind is more conducive to a high state of the barometer than any other. When the mercury rises or falls steadily for two or three days together, it is generally found that a long continuance of settled weather will follow; rainy in the latter case, and fine and dry in the former. By the same rules, frequent fluctuations in the height of the column are found to coincide with unsettled weather.

Another authority says that those who have observed most carefully the connections of barometric heights with changes of the weather, discard entirely the use of these terms, and state that it is

not the actual height of the barometer at any place, but this height as compared with that of surrounding regions, which indicates the coming weather. Codes of rules cannot be drawn up to serve as a key to the variations, they will always be more or less of a local character merely. Generally speaking, a falling barometer indicates rain, a rising one fair weather. A steady one foretells a continuance of the weather at the time; when low, this is generally broken or bad, and when high, fair. A sudden fall usually precedes a storm, the violence of which is in proportion to the barometric gradient. An unsteady barometer shows an unsettled state of weather; gradual changes the approach of some permanent condition of it. The variations must also be interpreted with reference to the prevailing winds, each different wind having some peculiar rules. The connections between changes of weather and the pressure of the atmosphere is by no means well understood. One reason is given, which may to some extent account for the barometer being lower in wet than in dry weather, since, as has been shown by Dalton, moist air is lighter than dry air, wherever a large amount of aqueous vapor has displaced a part of the drier air, the barometric column will read relatively low. Hence much depends on the nature of the winds.

The correction of the barometer for temperature is of importance. Mercury expands $\frac{1}{1000}$ of its bulk for every degree of Fahrenheit's thermometer; consequently a column of 30 inches, at 32° F., or the freezing point, would at 65° F., for instance, be $\frac{65-32}{1000}$ times 30 inches, or nearly $\frac{1}{10}$ of an inch longer, for $30\frac{1}{10}$ inches of mercury at 60° , produces the same pressure as 30 inches of it at 32° . In order, therefore, that all observations may be compared correctly with each other, the observed heights are reduced to what they would be at 32° F., as a standard temperature. The rule for reduction is very simple: Multiply the number of degrees above or below 32° F., by the observed height, divide the product by 9990, and subtract or add the quotient from or to the observed height for the reduced height.

Beside its meteorological function, the barometer also serves for measuring the height of mountains. According to Mariotte's law, the lower strata of air are denser than the upper, consequently, when a barometer is at the foot of a mountain, the pressure it sustains is greater than that to which it is subjected at the top, by the weight of the column of air intervening between the top and the bottom. A formula of considerable complexity has been given by mathematicians for computing very nearly the true height of a mountain from barometrical and thermometrical observations, made both at its base and summit. It would, however, be beyond the sphere of this article to enter into minute explanations concerning the nature and operations of such a formula, and we will confine ourself to the general statement by saying that if the barometrical height at sea level is assumed at 760 millimeters, it will only be 759 millimeters at a height of very nearly 10.5 meters. According to Mariotte's law quoted above, the lower air strata are denser than the upper, and in order to experience a second fall of one millimeter of the mercurial column, a somewhat higher elevation than 10.5 meters must be reached, owing to the already more rarified air, etc. Formula, taking notice of these corrections, have been calculated. The law reads as follows: "The temperature remaining the same, the volume of a given mass of gas is in inverse ratio to the pressure which it sustains."

And thus, the simple experiment of Torricelli not alone visibly represents to us the effect of attraction, it is not alone a measure to tell us our distance from the center of our home, the earth, it also renders visible to us the ebbs and floods of the aerial ocean, and becomes to our imagination a bridge that unites the earth and the sun.

Lathes and Lathe Work.

BY THE MODEL WATCHMAKER.

TO CONTINUE the subject of jewel setting, the commonest job after scapement or balance hole jewels is the plate jewels of English lever watches. The method in a general sense is not different from that described for balance hole settings, but the points to be described are, first, the methods of securing the jewels in the

plate, and second, the fitting of the setting in the plate. In turning, the same course is pursued as described in last article, except the flat face on top which corresponds to the upper surface of the plate; this should be left high or full, and reduced by degrees by laying the jewel setting on a fine file and rubbing back and forth until reduced to nearly the right level; after which it is polished as described in last number.

If an extra fine and perfect job is desired, after the concave descending from the flat front face of the setting is turned with a polished graver; a still finer polish can be given with gold rouge and a piece of chamois skin rolled up like a crayon painter's *stomp*, and the end of it cut to a point, after a perfect polish is obtained on the concave or beveled surface; this surface should be painted over with shellac dissolved in alcohol, or what is better, isinglass (fish-glue) dissolved in alcohol or water. The object in this course is to secure a perfect polish to the very edge. To explain, if we should take a jewel setting polished as described, and after filing the flat front face put it on a ground glass with rotten stone and oil, to remove the file marks; the rotten stone would destroy the polish of the beveled surface for a little way back, and the result would be a dirty, smeared ring between the surfaces, caused by the rotten stone working up on and embedding itself into the beveled surface. If, on the other hand, the beveled surface is protected with a coating of isinglass, when the grinding is done it is protected from this action. When the grinding is done, to remove the file marks, with oil and rotten stone, a crumb of soft bread will take off the grit, and diamantine and oil on a tin lap gives a fine flat polish. Now wash with a soft brush and water to remove the isinglass, and you will find the angle joining the flat and beveled surface clean and sharp cut, and perfectly polished to the extreme edge, without any rounding off or worn look. The screws which hold the setting in place have half the countersink cut

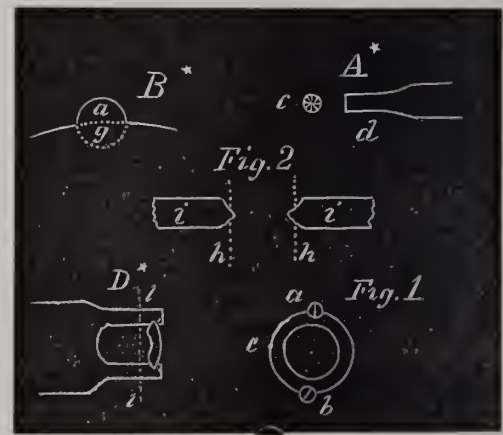

in the plate and half in the setting. To do this nicely, the jewel setting should fit close into the plate, so as to require some force to press it into position; and after the filing (by rubbing as described above) is nearly complete, the jewel, with its setting, is pushed firmly into position, and the guide pit which serves to indicate the position of the jewel when in place; this guide pit is indicated by the dotted line at *e*. This pit is best made with the point of a triangular countersink.

The countersinks for the screws are made by cutting with a graver the jewel setting so as to make a recess for the rose drill to act. At *B** is a diagram of screw countersink very much enlarged; the dotted line *ff*, showing the curvature of the jewel setting, the half circle in dotted lines at *g* indicating the portion of the setting to be cut away; a graver is used to cut out in a concave the part inside the dotted line *g*. A rose drill shown at *A**, turned to the size of the screw head and filed into teeth as shown at *c* (end view) will countersink for the screw almost instantly. If the setting containing the jewel should be turned so as to be too loose in the plate to hold for all these manipulations, it can be cemented in with shellac dissolved in alcohol; but careful turning to a measuring gauge will ensure a close fit, and it is a silver, if not a golden maxim, never to use cement or soft solder when it can be avoided. Although in many cases the use of

soft solder is almost indispensable; and in no place more indispensable than in replacing jewels in Swiss watches where the sink in which the jewel is set has been destroyed, and the cementing in of a hole jewel with shellac is abominable. This condition occurs more frequently in the foot balance hole jewel than any other.

To re-place a jewel where the setting has been destroyed, you proceed very much as described in the January number of THE CIRCULAR for setting balance holes, although as a rule smaller wire can be used. But the first necessary operation is to broach out the old jewel hole in the plate to a larger size than even the full diameter of the jewel to be set. At fig. 2 is shown a vertical section of a watch plate enlarged, *ii* representing the plate, *hh* (the dotted lines) shows where and to what extent the broaching out is carried; but the broaching out is to be varied somewhat, as will be explained below. The jewel is set as described (in January number) and shown at *D**, only it is not turned outside quite as small as the hole is broached out to; it should now be cut nicely off at the dotted line *l*, which is intended to be of the same height as the inside of the plate *i*. The hole represented by the dotted lines *hh* is now broached so that the jewel and setting can be pushed in from the inside; this pushing in should be so done that the jewel is, as regards the location, precisely as the old one was (if right); at any rate the jewel can be put in the proper position, and a little soft solder applied at the lower end and flowed into the joint. The wire can now be broken off at the dotted line *l*, and after immersing the plate in a solution of cyanide of potassium to destroy and annul the soldering fluid, wash with soap and water or alcohol. The inside portion of the setting can now be finished with one of your round Swiss countersinks, and the watch practically is as good as ever, and the soft solder is only to be detected when the lower cap jewel is removed, and even this clue can be destroyed by the skilful use of the universal lathe.

This system of setting jewels can be taken advantage of to change depths when these are faulty. A few words on depths. Many watchmakers are terribly troubled with bad depths; one is too shallow, another too deep. Now most of this sort of thing is imaginary; nine times out of ten, the watch, when it comes from the watchmaker, even if a poor cheap concern, is pretty nearly right, and the so-named faults of depthing lie in the offending wheel being out of round, *i. e.*, the wheel works all right except when it comes around to one place, then it catches. Try this wheel in the calipers and see if this is not the full side, if it is, this part does not want to be dressed off, for the very fact that if this side is too full, the opposite side must be too scant. Go about such a job in a sensible way; knock the wheel off the pinion, and if the shoulder of the pinion is out of true, turn it, true and close up the hole in the wheel—or even bush it, or in any way (except to file the teeth) get the wheel true, and ninety-nine times out of a hundred the watch will run.

A word here about anchor lever scape wheels. These are frequently out of true so much as to sadly interfere with the performance of the watch, if not to actually stop it. To cure this, first ascertain if it is in the wheel or a fault in the manner it is mounted on the pinion; as a common fault is to turn the seat on the pinion too small, and then *smash* on the scape wheel some way, riveting down the shoulder to fit the hole; in this way more scape wheels are thrown out of true than any other. A new pinion is the most workmanlike way to remedy this, but by carefully closing the hole and returning the seat, the old pinion can be used. To close the hole in a steel scape wheel would in many cases be attended with danger, as the wheel is hardened. The mere surrounding of the hole can be softened by running a red hot taper wire into the hole. This softens only the center. Muriatic acid will remove the color, and the upper face should be repolished.

Simple Method for Gilding.

(Concluded.)

AFTER ALL the preparations necessary for insuring a good success have been made, we come to the work of gilding. For this purpose take a porcelain dish sufficiently large to well accommodate

the article to be gilt, and pour into it as much of the gilding fluid as is necessary to fully submerge the article; next place the vessel, together with the fluid, either upon a stove or above an alcohol flame, and heat nearly to boiling, without permitting it to arrive at this point. While the fluid is heating, take a strip of zinc about one centimeter broad and scratch it about as far as it will afterward dip into the fluid, removing by the operation of scratching all the oxide, so that the bright metal appears. The article to be gilt is now suspended from the end of the zinc strip. In cases when it is so small that it can be suspended only with difficulty, the strip is left broader, from three to four centimeters, forming the end into the shape of a spoon, and placing the article into the depression thus made. The above-described process is the same in other respects. When the fluid has reached the degree of heat above mentioned, the articles suspended on the zinc strip are immersed in it. They are taken out again in from 1 to 1½ minutes, rinsed in plenty pure, and, if possible, warm water (35° to 40° C), and then scratch-brushed with a brass or glass brush, using beer or vinegar; we will recur to this part of the work hereafter. The suspending, rinsing and scratch-brushing is repeated several times, until the desired thickness of the gold coating is secured. When this has ensued, the used strip of zinc is again cleansed in the most careful manner, the articles are again suspended from it and again brought for a moment into the fluid, moving them in it continually, but only up to the time that they have assumed a handsome high yellow color, since by a prolonged continuation in the bath, their handsomest color disappears again. As soon as you see that the desired tone of color has been obtained, remove the articles from the bath, rinse off in good hot water (done for the purpose of causing them to dry quickly of themselves), and dry without additional scratching, best is hot sawdust, or in the case of flat articles without depression, a clean linen cloth. If all the different processes have been well adhered to, an excellent fiery gilding will be the result, and the operator will be satisfied with the success of his labors.

It is necessary next to be somewhat more explicit about the operation of scratch-brushing, because there may be several of our readers who are unacquainted with the work. By the word scratch-brushing is understood the operation of removing the mat color covering the article, or simply cleaning the surface by rubbing with a quantity of fine brass wires or glass threads. The instrument used for the purpose is called scratch-brush, and its form and construction varies according to its purpose. The operation of scratching is never done dry; the brush, as well as the article, must constantly be moistened with a fluid, which sometimes has a chemical influence; generally, however, it is done for the purpose of lessening the friction of the scratch-brush and of removing all the impurities which it might detach. The scratch-brush is, as it were, the touchstone of metallic coatings; if the conditions specified in the preceding were adhered to, the article is only brightened by the friction of the scratch-brushing; in a contrary case the coating peels off, it is detached in little scales, because it does not adhere sufficiently firm upon the underlying metal. When scratch-brushing, the brush is moistened with beer, vinegar or acidulated water, and is conducted over the article similar to a paint brush. The greatest care must be bestowed upon these brass scratch-brushes, and the single wires must always be retained as evenly and stiffly as possible.

To effect this, they must be drawn from time to time over a rubbing iron, whereby they are straightened again; the brush is to be drawn over it several times, exerting a strong pressure, following the direction of the wires.

For scratch-brushing delicate articles, such as we treat of almost exclusively in this article, brushes of spun glass threads have lately been used with best effects and advantage, since they can be used not alone for producing luster, but also for mat brushing. For luster brushing they are used in the same manner as the brass brushes described in the preceding lines, with one exception, that in place of the cold, a hot liquid is used, experience having established that

a glass brush is subject to a far less wear in a hot than in a cold fluid. When mat scratching, an operation chiefly occurring with watch parts, the motion is less a rubbing than a puncturing one, in such a manner that the ends of the glass threads always strike against the metallic face to be manipulated nearly at right angles, in this manner producing thousands of microscopically small punctures. It is not difficult with a little practice, to obtain a very satisfactory mat by means of this instrument; it must not be expected, however, that the admirable appearance can be produced, shown, for instance, by a new gilt bridge, since it would be impossible to undertake the several processes necessary for this purpose a second time without incurring the risk of ruining more than correcting. Nevertheless, a bridge gilt in the above manner will always be of a very creditable appearance.

The gold coating, produced according to the above directions, will now be of a pure fiery gold color; but since it would often be desirable to obtain a more reddish or greenish one, we will in conclusion give the necessary directions for producing such colors. If a reddish color is desired, dissolve at the same time in the gold, when preparing the gold chloride, a little chemically-pure copper in the nitromuriatic acid—use more or less, according as the color to be obtained is to be paler or higher red; in other respects, proceed as above said, but take care not to overdo the thing; you would only be unsuccessful, since a stronger galvanic current would be necessary for decomposing the bath, and a single strip of zinc would not be capable of furnishing it. A greenish gilding is obtained if a little quantity of silver chloride is added to the already prepared bath, as long as it is still boiling.

Fearing that I may have been rather verbose and tedious in the above description, which could not be well prevented, however, considering the subject matter, many of my readers may have come to the conclusion that the process is very tedious and complicated, wherefore I sum it up under the following short headings:

1. The preparation of the gold chloride.
2. The preparation of the bath.
3. The cleansing of the articles with potash solution and rinsing them in pure water.
4. Suspension to zinc strip and introducing into the hot gilding bath.
5. Rinsing, scratch-brushing and drying of the articles.

If it is considered that a bath, once produced, serves for a very great number of articles, and in the practice of a watchmaker, who perhaps uses it once a week, it will last for one or two years, it will be seen that the process can well be called simple. A trial will show what an infinitely large number of articles may be gilt from one such a bath, and the watchmaker will finally inquire wonderingly from whence all the gold comes.

SILVERING BATH.

Silvering also is of importance for the watchmaker, although not in the same degree as gilding.

It may also be produced in different manners, amongst which especially the cold and the galvanic silvering may be mentioned. But since the latter method is only very rarely, or perhaps, never employed by the watchmaker, and beside this, demands a strong galvanic current, we will simply consider the subject of cold silvering.

Cold silvering is used for imparting dials and other faces, for which a handsome, uniformly mat white color is necessary, or else for imparting a uniform mat to articles that are to be mat gilt.

Cleaning and dipping of the surfaces to be silvered is effected in the same manner as was described for gilding. Also in this case the greatest cleanliness is a chief condition for the good success of the work.

We will have to describe:

1. *The preparation of the silver.*—Either fine silver or else such from broken up silver ware is used; it is of no consequence whether it be alloyed with other metals. It is rolled out into thin strips,

which are cut into pieces and also curled into small rolls, as was explained in the description of the gold bath. Nitric acid is poured over them, and they dissolve completely in it within a short time.

The solution need not be evaporated to remove any excess of acid, as was done by the gold solution; we will soon see that the solution, as such, is not used, but the metal only will have to be obtained as a finely-divided powder. An excess of acid, however, is best avoided by first pouring a small quantity upon the silver, and if the solution is not effected, more may be added.

This preparation of the silver solution is of value especially for those who have old silver to dispose of. If this is not the case, the far simpler method is to at once purchase the silver nitrate, kept in every drug store; it is also known by the name of *lapis infernalis*. It is generally sold in round rods, and do not take more than necessary. This saves at the same time the manipulation of the nitric acid and the many evils connected therewith, especially in a watchmaker's shop. Take a piece of this silver nitrate, seven to eight centimeters long, and dissolve it in one liter rain water. The solution must be clean and colorless.

There are two different methods for recovering the silver for silvering from this solution. Either strips of copper are suspended into the solution, whereby the silver withdraws from it and clings to the copper as a metallic powder, while a corresponding quantity of copper dissolves. As soon as nothing further precipitates from the fluid upon a fresh, clean strip of copper, it may be considered as exhausted of silver. The precipitates are then brushed with a plume from the copper into the fluid, waiting for a few minutes until everything has been settled. The entire collection is then filtered, and after all the fluid has escaped, pure water is added to the filtrate until it has lost every trace of acid. When this has dried upon the filter, the operator will have a very finely-grained powder of pure silver, which is to be stored in a glass flask. Before use, a proportion of one gram (15.43 grains, or about 15½ gr.) is added to one gram sea or table salt and one gram of cream of tartar, and a thick paste is formed of this by adding a little water.

Another and equally good method consists in adding a spoonful of table salt to the solution, whereby a white, cheesy precipitate, the chloride of silver, is formed. An excess of table salt is of no injury hereby. The precipitate requires some time, in order to deposit well; the fluid is decanted next, carefully, that no chloride of silver is lost. The vessel is filled again with pure water, the whole thoroughly stirred with a wood or glass rod, and after everything has well settled again, the water is poured off again, repeating this process until the water escapes without any salt or acid taste.

When all the water has been decanted, two good tablespoons full each of pulverized table salt and cream of tartar, are added, with which it is mixed into a stiff paste, which, until used, is kept in a glass or porcelain vessel; it must not be exposed to the light, because the chloride of silver would decompose.

It stands to reason that these salts must be perfectly clean, because if they were to contain even the smallest grains of sand, it is plain that they would ruin the surface.

Watch dials and other surfaces containing engraved parts and divisions are frequently to be silvered; for this purpose the engraving is first to be filled with good black sealing-wax. The plate is heated moderately, so that the sealing-wax, when slowly drawn across, just melts. The sealing-wax is drawn over the surface until every line and stroke is filled. Too great a heat is carefully to be avoided, because the wax would blister. The better the engraved plate was cleaned previously, the firmer the wax will adhere in the lines. The excess of the sealing wax has next to be removed, and a little pulverized pumice is strewn upon plate and ground by using a larger piece of pumice and plenty water, until all the wax has been ground away, except out of the lines. Grinding is next finished with a soft and clean waterstone until the marks of the pumice are worn out. The surface is rubbed with a clean cloth (not linen) and very fine pumice powder, and finally washed thoroughly with clean water.

The plate, still wet, is laid upon a flat table and the face is again rubbed with finely-ground salt, using a cotton rag. Without removing any of the salt covering the plate, a small quantity of the silvering paste corresponding to the size of the plate, prepared according to above directions, is placed upon it, and with a broad and stiff brush rubbed quickly and evenly over the whole face, until it is of a uniform mat white appearance. The silvering was formerly rubbed with the finger, ball of cloth, or a cork; a brush is generally used at present for effecting the purpose. When this has been effected another brush is at once employed and the surface brushed evenly with cream of tartar, whereby it becomes handsomely white. The plate is at once rinsed with plenty of clean water, and in order to clean it well it is dipped into hot water, the extra water is swung off, and the remainder soaked up with a cloth from the surface without rubbing. The dial or other plate is next to be slowly heated again, so that the sealing-wax in the lines, which had become mat from grinding, will reassume a luster. But be careful while doing this, otherwise the wax would either blister or run over and disfigure the engraving, and such an accident is almost without remedy.

A chief condition for the good success of the silvering is that the different labors, especially the last grinding and rubbing of the brass face, the application and brushing of the silver and of the cream of tartar, as well as the warming, be done quickly and in an uninterrupted succession. Should it become necessary to interrupt the process at any time, always keep the dial under water during the suspension, until you are able to continue the work.

In order to protect the surface of the silvered plate against atmospheric influences, coat it with a colorless alcohol varnish, such as is used for photographs.

Articles intended to be gilt may also be provided with a mat surface by silvering, instead of by treating them with acids, as was described previously; the same process is employed for this.

We finish by giving a short review of the whole process necessary for the preparation of mat silvering:

1. Dissolving the nitrate of silver.
 2. Precipitating with copper or table salt.
 3. Mixing the silver precipitate with table salt and cream of tartar.
- The above points embrace the preparation; the following pertain to the silvering process:

1. First grinding of the plate or dial.
2. Applying the sealing-wax to the engraving,
3. Grinding of the excess of the sealing-wax.
4. Finishing the grinding by the use of waterstone.
5. Rubbing off with pumice powder and washing.
6. Rubbing with table salt.
7. Applying the silvering.
8. Brushing off with cream of tartar and washing.
9. Warming, to restore the luster of the sealing-wax.
10. Lacquering.

He who adheres with fidelity to these directions will be able to produce a very handsome silvering in a short time. All the conditions necessary for this work are so simple and cheap as to be within reach of everybody.

Gold and Silver—their Elaboration.

(Continued from Page 26.)

FOR ESPECIALLY delicate colors, chiefly for tones to be produced with gold purple, from rose red to deep purple, it is better to use the following covering mass, because it fuses more easily, and has no influence upon the most delicate colors:

II.

	Weight parts.
Quartz flour.....	3
Washed chalk.....	1
Calcined borax.....	3

Many enamel painters first melt the covering mass upon the ground mass, and only paint the picture upon the former; this work may be

simplified, however, by melting the covering mass at once with the color and then painting with this mixture. The covering mass then smelts together with the color and adheres to the ground mass.

For the production of these smelting colors, the pulverized covering mass is changed into a very fine powder by washing; this is mixed with the corresponding color in well-defined proportions, and the color charge is then remelted in small crucibles. After this colored mass has again been pulverized and washed, it may be used for painting.

It will be seen that only one deeply-colored shade is obtained with this smelting color, in order to possess gradations, the mass must be made lighter by the addition of colorless covering substance, and it is well to prepare a set of ten numbers, in such a manner that the pure substance (the darkest color) is called No. 1; a slightly paler shade, No. 2, is obtained by smelting 90 parts No. 1 and 10 parts colorless mass; No. 3 consists of 80 parts No. 1 and 20 parts colorless mass, etc.

In order to be sure at all times how a color will appear and behave when melted upon the white ground mass, a sample plate must be prepared, upon which samples of the colors from No. 1 to No. 10 are applied and smelted in.

But the painter has frequently not enough with these ten gradations of a shade, and in order to produce one lying between two tones, he must depend upon his experience, by mixing sufficient of a dark color with the colorless covering mass, in order to obtain the desired gradation of shade.

The application of the colors upon the coloring mass is done with the brush, and they are rubbed with lavender oil. The completed picture is now submitted to burning in, and it is of the greatest importance to proceed with due caution and care, because, by a careless treatment, the entire laborious work bestowed upon the production of a picture, may be utterly ruined in the very last moment.

The muffle in which the article is to be burned must only be heated sufficiently so that its heat will melt the glass mass of the covering substance; the article is at first slowly heated, because by a violent heating, in consequence of the unequal expansion of the enamel mass and metal, a chipping or cracking of the enamel layer might be provoked. The gradually heated articles are then completely pushed into the muffle, and left in it until the covering mass comes into a flux and combines with the ground mass.

The covering mass will become so liquid by too strong a heating that the single colors run into each other, whereby such a badly treated article will not show the picture in clear, well-defined outlines, but melted together; an occurrence especially disagreeable with delicate, small paintings, such as are often placed upon articles of ornament.

ENAMELING WITH ENAMELING PASTE.

It will be seen by the above that enamel painting is an exceedingly tedious, laborious work, and real enamel painting can only be executed on costly articles. It is frequently desired, however, that articles of lesser value be also enameled, and this can be done in a more expeditious manner by the use of the so-called enamel paste. This consists of a covering mass, which by suitable alteration of the mixture proportions, has been rendered more fusible, for instance according to the following proportions:

Quartz sand.....	Weight parts, 60
Chalk.....	" 30
Calcined borax.....	" 60
Minium ..	" 10 to 30
Tin oxide.....	" 50 to 90

The once-melted mass is coarsely pulverized and again melted with an addition of those pigments that withstand a great heat. Colored masses are thus obtained which, according to the amount of pigment employed, possess lighter or darker shades, for instance, by protoxide of cobalt it ranges from the bright forget-me-not blue to the darkest violet blue; by ferro-oxide of alumina, deep red; by protoxide of iron, black, etc.

These color pastes, in a melted condition, are poured into water, pulverized and burned in, when to be applied upon larger surfaces, in the muffle; upon smaller, simply with the blowpipe. Before applying the enamel mass, the brightened metallic surface is moistened with borax solution, the mass applied, first heated upon live coals, to effect the entire expulsion of the water, and then melted. The entire work of the enameling is here executed in one single operation.

THE ENAMEL COLORS.

The enamel painter has a pretty large number of pigments at his disposal, and by suitable mixtures he is enabled to produce every shade of color. His *palette* consists of the following colors:

For white—Oxide of tin.

For yellow—Antimony oxide, antimorionic potash, antimoniate of potash, antimoniate of lead, silver oxide, iron oxide, uranium oxide.

For red—Ferro-oxide of alumina, sodio-auric chloride, stannic chloride, Cassius purple.

For orange—Mixtures of yellow and red-brown coloring pigments.

For green—Copper oxide, chromic oxide, protoxide of iron.

For blue—Protoxide of cobalt, silicate of cobalt (the so-called smalts), safflower.

For violet—Manganese oxide.

For brown—Iron oxide.

For black—Protoxide of iron in larger quantities.

We omit an explanation of the process for manufacturing colors with the assistance of these agents, since this preparation is actually neither the task of the enamel painter nor the goldsmith, but of the chemist, and we have treated of the above simply because we could not avoid a short explanation, since the matter, as a whole, pertains to the art of the goldsmith. We next come to the

EMAILLE CLOISONNEE.

(*Deepened enamel*, Eng., *Grubenschmelz*, Germ.)

This kind of production of enameled work differs, with respect to materials employed, in nothing from the preceding method; the difference only consists in the manner of applying the enamel. While in the ordinary way, enameling is always applied to the surface of the articles, in the case of deepened enamel it is placed into deepenings, or cells.

To judge by the ancient specimens of goldsmithing found in art collections, and especially by the appearance of ancient Chinese samples, the production of this kind far antedates that of the surface enameling; undoubtedly, it was desired to render the enamel in several colors, and no other means was known but to separate each color, as it were, by a partition wall, or cell. With the present advance of the art, this is no longer necessary, still, it is quite often employed for the production of geometrical figures. If it is desired to produce this deepened enamel strictly according to the ancient method, the copper, silver, or gold plates must be pretty thick, because the cells have to be sunk into them. The sketch to be executed in colors is to be drawn with fine lines upon the metal, and this is worked out with cutting instruments in such a manner that as many cells are produced as colors desired. The separations of the cells is always effected by a very thin metal wall, to be left standing when excavating the former, and it depends upon the skill of the workman to produce them as thin as possible, in order to be little visible. Their bottom is roughened with the graver for the purpose of effecting the greatest possible adhesion.

The enameling mass is stirred to a stiff paste with lavender oil, placed into the cells with a spatula and uniformly pressed down. When all cells have been filled in this manner with the enameling powder, the article is placed into the hot muffle of the furnace, and the enamel melted by strong heat.

The fused enamel shrinks very materially in volume, wherefore it is necessary to apply the enameling powder twice, in many cases three times, and to melt it in until the cells are completely filled.

When the enameling mass is of the desired thickness, the entire surface is ground and polished. The working out of the cells is a

troublesome piece of work, on account of the great care necessary not to injure the dividing walls. The cells are produced by soldering uniformly broad and very thin strips of gold plate upon the under face, in the shapes intended for the cells to have. They are then filled with enamel, as above described.

THE ENAMEL CHAMP-LINEE.

This kind of enameling is for the purpose of producing imitations of genuine cell-enamel in a simple manner. Hollows are pressed by means of steel punches into very thin gold plate, and then filled up with enamel. Stars, straight-line and other geometric figures can in this manner be produced more exact and handsome than by working by free hand. They must be stiffened, however, otherwise the enamel would chip out, which is done by coating them on the underside with an easily-fusible alloy.

XVIII.

THE PLATING PROCESS.

It is natural to suppose that persons of small means would also desire to purchase trinkets and personal adornments; the artistically embellished gold article was too costly for them, and an adulteration of the precious metal was next at hand; this led to the process of plating, both gold and silver, done in such a manner that a sheet of copper is on either side coated with a sheet of gold; the three sheets are then rolled out to the required thinness.

The manufacture of plated ware is an invention made in the beginning of this century. It was a remunerative branch of business up to the time that alloys were invented similar to silver in appearance, and changing only with difficulty in air, and to the time of the invention of galvanic gilding and silvering.

GOLD PLATING—TALMI GOLD.

The genuine gold plate is composed of a copper-zinc alloy (brass), generally containing 90 per cent. copper and 10 per cent. zinc, of a rather agreeable color, and what is of more value in this instance, possessing a great ductility. When articles manufactured from gold plate are of such a nature that the single pieces are soldered together, the plating is necessary only upon one side.

In order to produce a really durable ware, the proportion between gold and underlay must never sink below a certain ratio, and one per cent. gold of the weight of the alloy is the standard for a good ware. If, consequently, the brass sheet of about two millimeters thick weighs one kilogram, a gold sheet of ten grams is requisite for an efficient plating, and very fine gold is used, in order not to be annoyed with much boiling.

The brass sheet to be plated is first made perfectly smooth by rolling, brightened with a fine file, and roughened with pumice stone. After the pumice powder has been carefully removed by wiping the plate with soft cotton, the thin gold is spread upon the sheet and pressed on moderately strong with a burnishing steel. This pressing is only for the purpose of uniting the two metallic surfaces so that no air bubbles remain between.

The plated sheet is now passed several times between brightly polished rollers, under moderate pressure; less to be stretched than to effect the intimate combination of the metals. The sheet is then slowly glow-heated, and while still hot, rolled as quickly as possible into thin sheets, sometimes not thicker than writing paper.

Through this repeated rolling, both gold and brass are united into an inseparable whole, and this gold plating, on account of its density, possesses a much greater durability than one that was produced by galvanism, although this may be much thicker, wherefore gold plate is far superior.

The manufacture of plated ware is almost exclusively done by stamping out the pieces; they are next soldered together, and subjected to boiling for a short time in a sulphuric acid bath. The ready articles are sometimes filled with resin cement, in order to prevent them from being crushed; others use Babbit metal.

The coating upon a good gold-plated article must be sufficiently

thick, so that, for instance, a ring can be worn for two years before the underlay appears. But gold-plated articles are frequently found in commerce with coating so thin that it resembles a breath, and, as a matter of course, such goods will in the shortest space of time look very shabby; they are entirely without value, while those of Talmi gold (plated) possess a certain intrinsic value.

This kind of plate is manufactured by brightening a brass sheet, providing it with parallel cuts by means of a knife, and covering it with gold leaf. When this has been pressed firm with a burnishing steel, a second and third layer is laid upon it; the sheet is then rolled until sufficiently thin.

Ornamentations upon gun barrels are produced in a similar manner: The designs are slightly engraven upon the metal and covered with gold leaf, which is pressed firm with cotton; the excess of gold is removed, the design overlaid again, and this process is continued until the engraving is entirely filled with gold. It is then compressed by strongly passing over it a burnishing steel, whereby an adhesion is effected.

More firmly adhering gold coating are obtained by heating the steel nearly to glow-heat; the gold leaf is quickly laid upon it with cotton, and the covered places are rubbed with the burnishing steel until the metal is cold.

SILVER PLATING.

Silver plating is chiefly done upon copper, brass, and, of late years, also upon German silver; if German silver is plated with silver of a proper thickness, it is not inferior either in beauty or durability to genuine silver, and on account of the greater hardness of the silver coating, it is much more valuable than if coated with silver in the galvanic way. This silver plate is especially suited for the manufacture of trays, tea and coffee pots and milk pitchers, and for a variety of other uses.

The silver percentage of plated goods differs greatly, according to the nature of the articles; by fine goods, it is $\frac{1}{10}$ of the weight of the entire article, by table service $\frac{1}{12}$, and by buttons and harness $\frac{1}{16}$.

The copper sheets to be plated—very fine copper is always to be used for this purpose, on account of ductility—must be perfectly smooth, and are cut into pieces of 10 millimeters thickness and 10 kilograms weight. The plate is then worked with the file until thoroughly bright and rough; it is next coated with the silver sheet, the face of which coming into contact with the copper, is also to be made bright and rough, and cut sufficiently large so as to extend a little beyond the rim of the copper sheet; this protruding part is bent round with the hammer.

To prevent the falling apart of the sheets, they are wrapped with brass wire and placed standing vertically for a short time into an aqueous borax solution. It is highly commendable to dip the copper sheets, before layering them with the silver, for a few moments into a solution of nitrate of silver; they are covered therein with a thin film of silver, which contributes materially toward firmly uniting the copper with the silver sheet.

The sheet, when removed from the borax solution, is laid upon live coals, covered with them and heated to strong glow-heat, removed and rubbed with as hard a pressure as possible, using the burnishing steel, to unite the silver and copper. After the sheet has again been glow-heated, it is placed between the rollers and reduced to the corresponding thickness.

Brass sheets must be tinned before being plated. The sheet is for this purpose dipped to brightness in nitric acid, rinsed in water, dried and heated nearly to the fusing point of pure tin. Upon the sheet, laid horizontal, finely pulverized colophonium is strewn, the finest tin in a state of fusion is poured upon it, and uniformly distributed over it with a tow-ball; the sheet is then passed several times through smooth rollers, so as to give it uniform thickness.

The fastening of the silver sheet is done in a manner similar to copper, but a sal ammoniac solution instead of one of borax, is employed in this instance, and the horizontally lying sheet is heated so strongly that the silver sheet melts together with the tin layer.

The rolling is also done in a hot condition, and the metal is glow-heated after having passed through the rollers a few times.

Aluminum also is recently covered with silver, whereby a plate of very small weight and the appearance of silver is obtained. The aluminum sheet is well cleaned, covered with silver sheet, this is covered with an iron sheet, and the whole pushed between two thick iron plates, which are heated to a dark red heat and placed in a hydraulic press that can exert a pressure of 100,000 kilograms upon a square centimeter (0.155 inch).

PLATINUM PLATE.

Although platinum, on account of its insignificant gray color, finds little employment in the manufacture of articles of personal adornment, still it is extensively used in the chemical industries, since, similar to gold, it is only soluble in nitro-muriatic acid, while it fuses only at a very high temperature. The high price of platinum—it is worth seven times as much as silver—however, makes larger platinum dishes, for instance evaporating apparatus for muriatic acid, very costly.

Copper has of late years been plated with platinum, and vessels worked from this resist chemical influence as well as those from pure platinum; sulphuric acid, for instance, can be evaporated in them, without being in any way attacked by the acid.

The copper sheets used for this plate must be of unexceptionally pure copper; they are first rolled to a thickness of from 7 to 5 mm., next brightened in dilute sulphuric acid, roughened by scouring with fine sand and then slightly silvered. This silvering may be executed either galvanically or by the cold silvering process.

For the production of the latter, one part chloride of silver, one part table salt, one part pulverized cream of tartar, and one part washed chalk, are mixed by prolonged grinding; a wet cork is dipped into the mixture and rubbed upon the copper sheet, which hereby receives at once a thin uniform silver coating.

The silver washed sheet is repeatedly rinsed with distilled water, carefully dried with soft cotton and covered with platinum leaf, as was specified under gold plating. The leaf is pressed down upon the metal, and the covering repeated four or six times. The resistance of the article increases with the number of platinum leaves; the last ones are laid on thus that they extend beyond the rim of the copper sheet.

This prepared sheet is then covered with a freshly glow-heated copper sheet, as thin as paper, which is bent down around the rims, when the whole is heated to nearly the fusing point of the copper, and under strong pressure passed through rollers. Platinum can be welded, and therefore the single leaves are united by the pressure of the rollers. This rolling is continued until the plate only glows feebly; it is then reheated and drawn out to the required thickness. The thin copper sheet lying upon the platinum, loosens of itself during the rolling. The ready-rolled plate is finally again passed through polishing rollers to impart a high luster to the platinum.

XIX.

GOLD AND SILVER PLATING.

As already mentioned in the preceding pages of this treatise, it is the aim of the gold and silversmith to give to the articles manufactured by him the color of the pure metals; he will also seek to do the same with articles of the base ones, and for this purpose he incloses them in a thin envelope of gold or silver. The production of these envelopes has progressed so far that it constitutes vocations independent of the goldsmith; the so-called galvanizing belongs to them.

We can only engage our attention with this subject in so far as it comes within the province of this work, and is an auxiliary of our profession. The subject of the actual gold or silver plating, elucidated in the previous chapter, belongs into this division, and it can undoubtedly be considered as the oldest of the group. The great softness and ductility of the precious metals make it possible for

them to be used for this purpose, and that they possess an incredible tenacity; the horse-back statue of the Emperor Marcus Aurelius, upon the Capitol square in Rome, which was gilt, has been exposed for more than fifteen centuries to all the vicissitudes of the weather, still shows in many places the unmistakable traces of gilding.

The art of fire gilding was invented at a later period by Italian workmen, but, as was frequently the case during the early and middle ages, they guarded it as a mystery.

The numerous methods for silvering and gilding, both by boiling and by the cold way, as well as those called "by contact," have nearly all been invented during the present era, when chemical knowledge had already far advanced, and many reagents had become known, by which the operator was empowered to separate the solutions of the precious metals from the bath, and precipitate them upon the article he desired to embellish.

When the discovery had been made that the electric current could be made subservient for precipitating metals upon any desired substance, it was not long before it was also discovered that this process was eminently practicable for providing base metals with a coating of gold and silver in the galvano-electric way. The process of silvering and gilding has rapidly supplanted nearly all the others, since such a precipitation adapts itself to all the conformation of surface of the article, and the thickness of the coating depends entirely upon the option of the operator.

THE GENERAL FEATURES OF GALVANIC SILVERING AND GILDING.

Two things are necessary to cover metallic articles with gold or silver by the galvano-electric method: First, a fluid containing the corresponding metals in form of such combinations that they can easily be decomposed by the electric current, and forced to precipitate in shape of a firm, adhering metal coating; second, an arrangement that furnishes a continuous electric current of sufficient strength.

Until recently, no other method was known for producing a continuous electric current than by way of galvanism—the submersion of two different metals in a fluid; it was reserved for our time to make the discovery that magnetism can be converted into electricity. Large factories on the continent make use of the so-called magneto-electric rotary machines, by the aid of which a current of any desired strength and duration may be produced, and at the same time far cheaper than by galvanism; smaller shops, of course, must retain the galvanic elements.

The manner in which the galvanic current is permitted to operate upon the bath containing the silver or gold in a state of solution, very materially influences the condition of the galvano-plastic metal coating. They become grained and not uniformly adhering, if the current is applied too strongly; the same is also the case if it varies in strength. A perfectly uniform coating is obtained only when the operating current is entirely constant.

It must, therefore, be the chief aim of the operator, who desires to be successful with galvano-plastic silvering or gilding, to familiarize himself with the physical features of this branch, so that he can regulate the effectiveness of the electric current with understanding.

XX.

GALVANIC SILVERING.

All the silver salts can so easily be decomposed by the electric current, that every soluble salt can be reduced therewith into metallic silver. The experience has been made, however, that the cyanide combinations of the silver furnish the handsomest results, and they are, therefore, without an exception, used for galvanic silvering.

Before entering on the subject, we wish to preface these remarks with a few words on the cyanide combinations. Without an exception they belong to the most violent poisons known, since they contain those ingredients which renders the prussic acid so deadly in its effects. Many of the cyanide combinations, for instance the cyanide of potassium, are so easily decomposed that they surrender prussic acid to the air; the peculiar feeble odor of the cyanide of potassium

is caused by the small quantities of prussic acid evolved from the salt. The greatest care is necessary in factories of this kind that the vessels containing these cyanide solutions are silvered, well covered, and that the workroom is well ventilated, so that fresh air can enter at all times. Again, no workman who has the least abrasion of skin on his hands is to be employed in its manipulation; the contact of the cyanide with such a place might engender a very grave sickness.

(To be Continued.)

Sight.

WHAT THE OPTICIAN SHOULD KNOW ABOUT OPTICS.

Based upon an extensive hospital experience in Austria, Germany, England and New York. By C. A. BUCKLIN, M. D., New York. Author of Detection and Correction of Visual Imperfections, Cause and Cure of Cross Eyes, Effects of Color on Distance, and Monograph on Astigmatism.

Continued from Page 29.

WE FIND that answering questions as they are asked gives to the optician just the information he desires. Since having adopted this practical way of treating our subject, our readers appear to take a much livelier interest in optics than ever before. We will therefore confine our efforts to answering the many practical enquiries we receive through the mail.

The writer of the following enquiry has described a difficulty which anyone is liable to meet at any time:

GALVESTON, Feb. 8, 1883.

C. A. BUCKLIN, M. D., New York.

Dear Sir: Having been a patient reader of your articles in THE JEWELERS' CIRCULAR on "Sight," caused me to write this letter, and lay before you a trouble that has come to my eyes, that possibly you might be able to do something for me if necessary.

My trouble with eyes is that I have a great deal of specks, filaments, especially when I look up at the heavens. When I look at them they vanish, or move to one side; but they are generally, constantly, there now. It is about two years ago that I first discovered this peculiar phenomena, and then at that time took a good deal of looking at bright heavens to see them; but since that time, they have increased considerable, that I now see them whenever I look on white paper, and at times are darker, larger and heavier than at other times. These peculiar filaments and spots have bright centers; when I look at the heavens the lines appear like a human hair would appear under a microscope. Enclosed you will find a rough sketch, of about how they look. In other

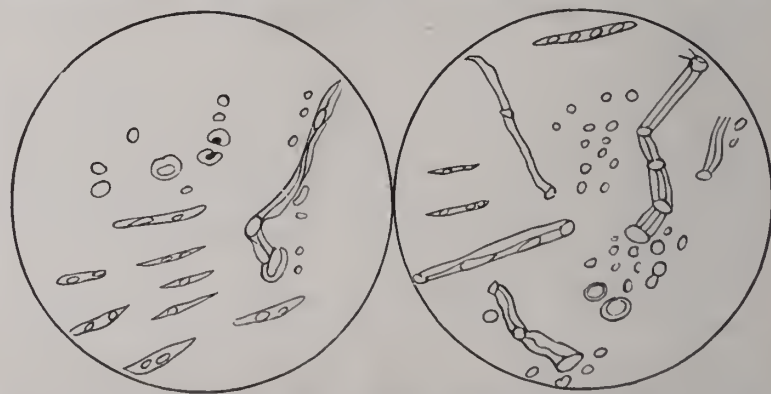

respects my eyes are as clear as they ever have been, and can read the finest prints on the test cards, but at times they appear heavy, dry, tender and tired. Regarding my general health, cannot say it is the best, and in general, rather nervous temper, (having worked at the watch repairing bench for eight years). I am forty-two years of age.

I hope that you will give me encouraging advice and instructions, what to do for this peculiar phenomena, which I have in both eyes, the right having the most, or seems to be the worst. They do not appear to be always the same—they change their size and position—sometimes very small, then again very large, that I see them in shadows, the greater the distance that I look the larger they appear. I hope that you will give this your attention at your leisure, and write to me what is best to do in the premises.

Yours respectfully,

CHAS. F. TRUBE.

Mr. Trube sees black specks in his eyes, as has already been

described. In all such cases the first thing to be determined is where are the *specks*, then we can draw a rational conclusion as to what they are. *First.* Are they upon the outer surface of the lens capsule? *Second.* Are they in the structure of the lens? *Third.* Are they in vitreous humor? Mr. T. is forty two years of age and the difficulty began only two years ago—this fact indicates that they are either upon the lens or in it. If they are upon the lens, they are inflammatory deposits from a previous inflammation of the iris. If this is the case, the development of the speck was preceded by inflamed eyes, which were very red and painful. To demonstrate the fact that the *specks* have not resulted from the above cause, take a solution of sulphate of atropia containing one grain of atropia to half an ounce of water; drop one drop of the solution into the worst eye every fifteen minutes till three drops have been used—then stop and await developments. If there has been a previous inflammation of the iris, the pupil will be found stuck fast to the surface of the lens, and as it grows larger you will see distinctly the points where it is stuck fast to the lens.

If there has been no previous trouble with the iris, the pupil will enlarge and retain its regular round form. The pupil will remain large for two days; in normal eyes the vision will be considerably disturbed during this period. If the specks which are in the eye are centrally located in the lens so as to be opposite the opening in the pupil when it is small, the enlargement of the pupil will improve the vision, because one can see around the specks. When the specks do not occupy the center of the lens, but on the contrary the center of the lens is the clearest point, the vision will be much worse while the pupil is enlarged. In no case where specks are complained of can the use of these drops do any harm to the eyes.

How to see the specks when in the lens.—The pupil having been dilated and still found to be round, the specks must be in the lens or in the eyeball (vitreous humor). Place the patient in a darkened room and have him fix his eyes upon some object straight in front of him. Then place a lighted lamp (with plain glass chimney) or a candle about two feet ahead of him and two feet to the right for the right eye or two feet to the left for the left eye, thus giving *oblique light* for each eye, which is absolutely necessary. Now take a *convex* lens, No. 2½, and focus the light on the dark pupil while the person is looking straight ahead, and if the specks are in the lens they will be distinctly seen by anyone as fine "milky" specks. If the specks are seen, the case is one of beginning cataract, they will gradually grow thicker and the vision poorer. I believe that the specks seen by Mr. Trube are in his lens; they may remain stationary without further development for years. If they are in the lens, as I suppose, he will probably have fully developed cataract within three years. If he has not cataract he will be able to demonstrate that he has not by the experiments above mentioned. If he has cataract and will wait till it is perfectly ripe, not wait too long after it is ripe, and not let some over-confident, lying, pretending expert gain his confidence, I can guarantee to restore his vision by removing the cataract. The best average results among the average reputable experts is about three failures for every ten cases. Some specialists have done much better. I have succeeded in removing cataract from fifty successive cases successfully. The causes of avoidable failure in my experience have been two:

First. The cataract was not in condition to be removed safely, and the operator had no idea of the difficulties which he had to overcome till the eye was lost.

Second. There are many specialists who are educated well, but they have not the slightest mechanical dexterity. I would much rather trust the operation in the hands of a good watchmaker, after I had carefully instructed him about the difficulties to be overcome, than trust many of the reputable specialists I see operating; they are clumsy, their lack of *mechanical* skill does incalculable injury, and they are frequently having failures without once suspecting the reason why. All men will have equal success in the removal of cataract if they know *when* to operate and they are *good* mechanics. Pro-

found learning will not answer; one must be a practical mechanic to have uniform success.

If Mr. T.'s trouble is cataract, and dilating his pupil does not improve his vision, he cannot do anything to improve it till the cataract is ripe.

The cataract is not ripe enough to remove as long as he can (with his back toward the window) count fingers held against a black coat at a greater distance than one foot. Should Mr. Trube on experimenting find that the specks are neither upon the surface of the lens or in its substance, or that in other words that the case is not "beginning cataract," then they are floating bodies in the *vitreous*, and further enquiries will be necessary regarding his general health. The fact that a disease is simple cataract which can at some future time be removed, I consider encouraging intelligence. I would advise him to let his eyes alone, and after trying the experiments suggested, to report to us his results. From now till the time his cataract is ripe, he must expect his sight to gradually fail him. The earlier it fails the sooner he can be freed from the black specks and have his sight restored. All kinds of remedies will be recommended, "electricity," etc., but if he does not pay any money till cured he will not be urged to try these remedies long. None of them will do any good.

Our next communication is an answer to our attempt to adjust cylindrical lenses to a person we never saw.

WILSON, KANS., Feb. 7, 1883.

To the Editor of the Jewelers' Circular:

The communication of C. A. Bucklin was received and read with eagerness, and I will tell how my eyes are, so that he can have a better understanding. To

Question 1. Answer is that the smallest block letter I can see with my right eye is 40, with my left eye 40, with both eyes 40; but when I use both eyes the letters 30 can be seen clearer, but not clear enough to distinguish them.

Question 2. *Convex* lenses make vision worse; the lower the number the more indistinct does everything become, 50 making letters appear better than 5, but yet more indistinct than without glasses.

Question 3. Concave lenses decidedly improve vision, can see letters x x clearer with 36 concave glasses than with any other, higher or lower, at 20 feet. Lower numbers make letters smaller and higher do not bring them out clear enough. One mile exactly, from my shop is a round post 6 inches in diameter and 10 feet long, on top of a hill, without glasses I can't see it. No. 30 convex just brings it in view, 24 makes it clearer, but 18 brings it out *very well*. The letters look the same with my right eye as with the left, and using both does not help me to read a smaller letter.

Question 4. Radiating lines do not look equally dark at 20 feet, the horizontal being the darkest with the right eye, also with the left, and by use of both at 50 feet all radiating lines appear indistinct, but by approaching the horizontal becomes clear first, which is about 35 feet. No matter how far away the lines are the horizontal is the darkest, or becomes so *first* on approaching nearer. Horizontal lines are clearest in right, left and both eyes.

Question 5. Best concave lenses (36 cv.) do not change appearance of radiating lines, but 24 cv. make horizontal and vertical alike, or vertical *slightest* amount darker; 18 cv. make vertical lines as clear as horizontal when latter seen *without* glasses. Now I have answered, I believe, all the questions, perhaps ambiguously, but I am so overjoyed that I may hope for relief that I want to make everything sure. I suppose spectacle frames, riding low, would be best adapted for the lenses.

Yours,

E. Y. DOLLENMAYER.

From question No. 1 we see that his acuteness of vision is $\frac{2}{4}$ of normal vision. The fact that he sees a little better with both eyes than with one shows that he has a visual defect which the slight enlargement of the pupil caused by closing one eye, makes still more confusing.

From question No. 2 we see that far-sightedness is no factor in the case.

From question No. 3 we see that he is able to read with a concave lens No. 36 better, which establishes the factor of near-sightedness, but it is a funny fact, that if this lens No. 36 is the best one, that it will not bring out the post one mile distant, but he goes as high as concave 18 before he gets the plainest view of the post. If the post was suspended horizontally in the air, No. 36 concave should bring it to

view, but as it stands vertically, No. 18 concave makes it very plain. I therefore conclude that he is $\frac{1}{36}$ near-sighted in *all* meridians, and as No. 18 makes objects plain which are vertical, the *horizontal meridian*, with which he estimates the thickness of the post, must have a degree of near-sightedness which is in excess of the vertical meridian as much as $\frac{1}{18}$ is in excess of $\frac{1}{36}$; $\frac{1}{18} - \frac{1}{36} = \frac{1}{36}$. We will therefore correct all meridians by placing before the eyes a concave lens No. 36, and will make an additional correction to the horizontal meridian by placing before the lens mentioned a pair of cylindrical lenses, concave 36, axis vertical. This will give all meridians a correction of $-\frac{1}{36}$, and the horizontal meridian a correction of $-\frac{1}{18}$.

Question No. 4 only confirms our conclusions. As he approaches the radiating lines (June number) the horizontal lines become distinct first, which shows that the vertical curve of the cornea is less sharp than the horizontal curve; I will suppose that Mr. D. could see that post with No. 20 concave plainly, as he probably accommodated slightly when he required No. 18 concave.

I will send him a pair of lenses in round frames with the axis plainly marked; the glass will be concave 36 with concave cylindrical No. 40, axis vertical. He can cover one eye and rotate the lens slightly by tilting the frame up and down. He may turn the axis of the lens to a horizontal position. If he finds any position of the axis (which is scratched) in which he can see better, he can unscrew the frame and rotate the lens to the most agreeable position. Screw it fast and return the frame by mail to us, and we will mount his glasses in riding bow frames. The attempt to fit such complicated lenses to one we never saw has never before been tried. It may not succeed, I feel sure it will, however. Let us await the result; if it is a success it is the biggest thing I ever heard of in practical optics.

LOUISVILLE, KY., Feb. 7, 1883.

C. A. BUCKLIN, M. D.

Dear Sir: We see you ask people to ask questions, so we take the liberty to trouble you a little. We read your articles in JEWELERS' CIRCULAR, and are pleased with the plain language in which you clothe your ideas.

Question 1. A customer who cannot call on us sees ordinary newspaper print at 20 inches with convex No. 14. What is the rule to determine what focus would be required to enable the party to see the same print at 12 inches?

Question 2. What rule will apply if the eyes are near-sighted, same example as above?

Question 3. What is the matter with a man's eyes when one of them has a halo around it—we should have said when a halo appears about a light when he looks at it? The halo is egg-shaped, and sometimes has all the colors of the rainbow at night.

Respectfully,

C. P. BARNES & BRO.

The third question of the above communication is of great practical importance. The person probably has an addition to the symptoms described, a *larger pupil* in the affected eye than in the other eye. To the careful touch through the lids, this eyeball probably feels unusually hard. This phenomenon can be present in cases where bad *glaucoma* is not the cause, but ninety times out of a hundred such an eye has *glaucoma*. This being the case, the eye will in time be completely destroyed unless operative influence is resorted to at a very early date. I should try the modern operation of *sclerotomy*. First, because it is an operation which, in competent hands, is free from danger; if it does not succeed it never does any harm, and iridectomy, the common cure for *glaucoma*, can be resorted to later if *sclerotomy* does not succeed. Iridectomy, however, cannot be said to be free from danger in *any* expert's hands, while *sclerotomy* can; until the patient concludes to consult a competent specialist, he should use in his eye the following drops four times a day: Sulphate of eserine, $\frac{1}{2}$ grain; water, 3 drachms. Drop one drop in the eye four times a day. This will produce an unpleasant sensation, but it will arrest temporarily the destructive progress of the disease.

I should not venture an answer to questions one and two, as there are so many disturbing conditions connected with a person's power of accommodation.

Question 1. If a person had an eyeball of the normal diameter, and possessed *no* accommodative power, he should be able to read common print at 20 inches with lenses No. 20 convex. If he requires No. 14 he cannot accommodate, owing to far-sightedness, for distant objects or parallel rays of light; he has to use a lens for parallel rays of light, the refractive index of which is $\frac{1}{14} - \frac{1}{20} = \frac{1}{48}$ —nearest lens to number. If he wishes to read the same point at 12 inches, convex 12 will deliver to his eye parallel rays of light from this point; this lens added to 48 convex, the lens he requires for parallel rays of light, $\frac{1}{12} + \frac{1}{48} = \frac{1}{9}$ about, or convex lens No. 9 is about the lens he should require to read at twelve inches, *providing twenty inches was the nearest point at which he could distinctly see the print through convex No. 14.*

Question 2. A person who requires concave 14 to read at 20 inches is about $\frac{1}{8}$ near-sighted, and probably if forced to read at 12 full inches distant, would see more distinctly through concave 30, but if left to make their own choice, they would only use glasses for the distance, and would read without spectacles.

A customer who could not call on me or pay me for going to him, I should let him see as best he could till he made it convenient to come and see me. He will come if you let him alone long enough. It is hard enough to provide a person with *correct* lenses when you have every opportunity for practical trial of glasses.

The Construction of a French Clock Anchor.

A CORRESPONDENT in the *Deutsche Uhrmacher Ztg.* asks for information about the quickest way for constructing an anchor for a French "pendule," to which Hermann Sievert responds as follows:

It may be presumed that the inquirer means an anchor for a ready clock, in which, consequently, both the center distance and the wheel are given. By means of a depthing tool transport the center distance *a b* upon a thin zinc or brass sheet, at *a* drill a small hole and fit the wheel arbor into it, so that the wheel can be laid flat upon the sheet. Next draw along the tooth points through point *b*, two lines *d b* and *b c*, and turn the wheel so that two tooth points are equally

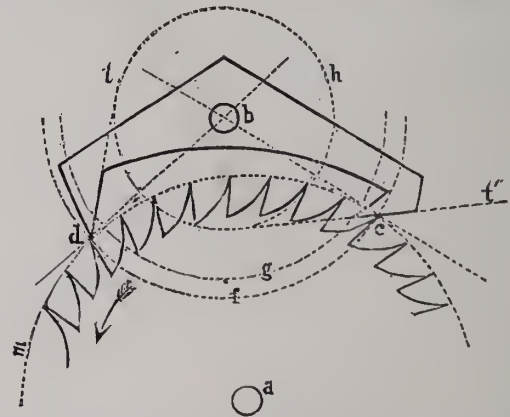

far from point *b*, and in such a manner that the two tooth points extend a little beyond the points of contact of the tangents. If the center distance is approachingly correct, then the two found tooth points will embrace about the one-fifth part of the whole circle—that of the sketch contains 36 teeth, consequently 7 tooth points. Mark the circumference of the wheel and the two points *c* and *d*, and through the obtained points, from *b*, draw the circle *f*. Within it draw the circle *g*, which intersects the tooth spaces in the middle, as well as circle *h*, the diameter of which is equal to about seven-tenths of that of the circle *g*. The tangents of the circle *h*, which pass through *c* and *d*, therefore *tt'*, indicate the direction of the lifting faces. If next the entrance lifting plane *c* is closed by the circle *g*, the most essential form of the anchor has been given. For transporting it upon steel only the three circles *f g h* are used, also the exactly gauged distance of the intersecting points *c d*, in order to determine thereby the line *tt'*, for the position of the lifting planes. After filing out the anchors two equal holes through it and at *b* of the zinc sheet, it may easily be fitted together with the wheel, upon this plate.

Instrument for Bending Breguet Springs.

THE ACCOMPANYING cut shows such an instrument in natural size, from which it will be seen that it is almost of the shape of a small vise. The utensil is made of steel, tempered and annealed. The fixed rectangular jaw is perforated and provided with a thread, so that the apparatus can, for better handling, be fastened to a brass plate by screw *a* and footpin *b*. For the upper screw, passing through the movable cheek, a thread is also cut in, while the lower one braces with its end against the rectangular piece, so as to retain the movable jaw parallel. The pin between the two screws is for the purpose of retaining the jaw in correct position. The upper part of the fixed jaw is rounded off according to the curve of the outer spring coil, and the movable one is hollowed out accordingly. The spring is kept firm without being bent, and the curves may, with a little practice, be bent easily, while a much greater dexterity is required to do it with the tweezers.

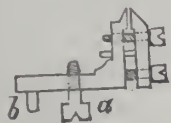

Fac Similes of Antiques.

HOW CLEARLY *fac similes* of the antiques can be produced is shown in the efforts of a well-known manufacturer in this city, who obtained the right to reproduce the Cyprus collection of jewelry of Mr. DeCesnola, and when they were completed and placed side by side with the originals the finder himself could not pick the originals out, and they were only distinguished by a private mark. Such handicraft, if turned from its legitimate course, would produce dire confusion among collectors, amateurs and professionals who probably now have many unsuspected "modern antiques" on hand. Among engraved gems there is the same difficulty. The first work of the Greek engravers came from the island of Samos, where Muesarchus, the father of Pythagoras, followed his trade as an engraver. From here came Theodorus, who cut the famous seal of emerald for Polycrates, which, according to some, was thrown into the sea. To prevent imitation or reproduction, a law was made by Solon, 600 B. C., forbidding engravers to retain impression of the seals they made. Thus fraud or counterfeiting was due to the carelessness of the owner of the seal. But the Romans boldly placed the names of eminent Grecian engravers upon their work. In the British Museum there is a garnet, presumably a figure of Jason, inscribed with the name of Phidias, while others fraudulently bear the names of Polycleus, Scopas and others. It is also true of later times, a good example of which can be seen in the collection of the same museum, where a chalcedony intaglio head of Alexander the Great, claiming to be the work of Pyrgoteles, is of undoubted modern origin. The heads of Augustus on jacinth and sard in the same collection, bearing the name of Dioscurides, the former from the famous Blacas collection, are of doubtful origin. Abbreviations of the names of the artists Dioscurides and Epitynchaus are always considered suspicious, and occur on many gems in famous collections.

Collecting gems was more of a passion among the ancient Romans than it is to-day, and as such opportunities are never lost by the unscrupulous, large quantities of genuine gems now rest under the suspicion that they are counterfeits. One of the celebrated Marlborough gems, the head of the dog-star Sirius, is condemned by Prof. Maskelyne, while other names about which there is much dispute are those of Hyllas, a son of Dioscurides, Agathopus, Enodus, Felix Myeon, Allson, Admon, and Onesos. Probably the boldest crop of imitations of the old Grecian masters came to light in the seventeenth century. The most noted imitators were Pilcher, Natter, and in England Merchant and Burch. To show how even experts of the time were deceived, there is in the Bibliothèque, in Paris, a gem (?) known as the signet of Michael Angelo, the subject being a bacchanalian scene, which it is said he so much admired that he copied from it one of the groups in his paintings in the Sistine Chapel. The gem, however, is evidently in this part of it a mere copy from

Michael Angelo's group and altogether a better production. As in other cases cited the collector has no relief but to be sure of his dealer. The actual imitation of the gem itself is a more difficult matter, yet many are worn by their unsuspecting owners, and their manufacture is a regular business in various parts of the world. Rubies are made of glass mixed with 50 per cent. of oxide of lead, a composition known as strass, which is the basis of nearly all imitation gems, different oxides being used to obtain the various tints required. For rubies the principal ingredients are silica, 38.2; red oxide of lead, 53.0; calcined potash, 1.8, and various parts of calcined borax, alumina, and arsenious acid; 1,000 parts of the above melted with 40 parts of glass of antimony, one part of purple cassus, and one in excess of gold, and the material when hardened will pass muster as a ruby in many quarters. The best imitations of gems came years ago from Italy, where a workman took as a base crystal, covering it with thin plates of the real stone he was imitating, fastening them on with colored glue. Many imitation diamonds are made in a similar way. Pearls are skilfully imitated in various ways. The silvery matter from the scales of certain fishes is used, the foundation of the pearl being glass or other material that will agree with the real gem in weight. The counterfeiting in pictures, statuary and other branches of art but repeats itself in every decade. Ancient armor, weapons, furniture, tapestry, etching, in fact, everything upon which hangs an interest on account of age, is made at the present day, and palmed off in one way or another by the unscrupulous dealer. It would hardly seem worth the while to copy the ruder works of art, yet the trade in fraudulent arrow-heads, Indian implements, etc., is a source of continual annoyance to the scientist. A man caught in the act of making flint arrows stated that it took him nearly three years to learn to do it, but he was so successful that his work could not be distinguished from that of the Indians themselves. A few years ago a brick or stone was found in Ohio that purported to bear an account of the deluge, and the amount of literature and scientific discussion this find produced was, to say the least, laughable, and there are still many who claim that it is authentic. It, or one like it, was offered for sale in New York, the consideration being a number of thousands of dollars. The Metropolis was wiser then than now and the offer was not taken. One of the most interesting classes of counterfeits are natural ones. Pieces of rock or flint that resemble the primitive works of man, and a collection of these, generally the workings of frost, when arranged and classified, might well pass for the rude works of man. Such collections, for the sake of comparison and for the benefit of the student, can be seen in Smithsonian and Museum of Natural History, Central Park.

Similar objects are often fitted up with rude handles and otherwise arranged and sold as Indian implements, finding purchasers among many who are not experts, though considering themselves proficient archæologists. Everything under the sun in demand is subjected to counterfeiting, fraud and adulteration.

Making Small Drills.

WATCHMAKERS' pivot drills can be made from good sewing needles, which are of convenient form to be readily converted into a drill. Firstly, the needle must be made sufficiently soft for working by heating it till it assumes a deep blue color. The extreme end may be made quite soft, and filed, slightly tapering to a trifle less than the size of the hole to be drilled. The point is now spread out by a sharp blow of a hammer, not by a series of gentle taps, which would cause the metal to crack, and filed up to shape, the point being made more blunt than would be used for drilling ordinary metal. For drilling tempered steel the cutting angles must also be much less than usual. The thickness of the drill across the flattened part should be about half the diametrical measurement. Finish up the end on a strip of Arkansas stone, a file being too coarse for such small work.

It is the great difficulty of getting such a very small piece of steel

to an exact predetermined degree of temperature—*i. e.*, hot enough to harden, but not so hot that it is burned—which makes the manufacture of these small tools uncertain, and this is abundantly proved by the fact that of half a dozen drills, made from the same piece of wire, thereby assuring uniformity of quality in the material, it often happens that some are exceedingly good and others of no use whatever, the difference being caused by the manipulation during hardening. This does not apply to drills or other steel things which are of sufficient size to show, by the color of their surface, how hot they are; but it is the tiny pieces which are rendered white hot by the contact with the flame.

By heating the drill and plunging it into the body of a tallow candle the hardening will be effected, but the steel will not be rendered so hard but that it crumbles away under pressure in use. Thus, in one operation, the drill will be hardened and tempered. Instead of tallow, white wax, sealing wax, and such like materials are adapted to the purpose. There is another method which finds favor with some; it is to envelop the thin point of the drill in a metal casing, and so get a bulk of metal which can be heated to a nicety, the drill inside being, of course, raised to the same temperature as the surrounding metal; the whole is then plunged into oil or water. Still there is the difficulty of tempering to overcome, though the danger of burning is avoided; burnt steel is no use for tools. The best plan is to exercise the greatest possible care not to overheat the drill, and harden and temper in one operation by plunging into tallow.

The following method dispenses with the hardening process altogether: Select a round Swiss pivot broach; as sold, they will be found to be tempered to the correct degree of hardness. By means of the split gauge, measure the part of the broach which is the exact diameter required for the intended hole, and break off the steel at that point; the small piece is used; it must be broken off if too long and cemented into a drill stock by shellac; an ordinary drill stock will do, or a piece of brass joint wire serves the purpose. Soft solder may be used instead of shellac, and, if carefully heated, the temper will not be drawn. The piece of tapering steel is now formed into a drill by grinding down the sides with a piece of Arkansas stone, and the end shaped up to a cutting angle. The thick end of the broach is, of course, the point, and the ordinary taper of a broach will be quite sufficient to give clearance to the drill, which may be ground off until the whole is used.

An Improved Process in Glass Etching.

DR. W. GRUNE, of Berlin, has lately patented a new process for etching on glass, in relief or opaque, directly resulting in a matted pattern by the corrosion of fluoric acid. The process is described as follows: Aqueous fluoric acid dissolves glass without exercising a visible influence upon the remaining surface, leaving it approximately bright. Profiting by this peculiarity in its corroding power, the inventor uses materials which have before been thought useless in consequence of their feeble resisting capacity. These substances, if placed upon glass in very thin layers, and even dried and hard, will yield in a few seconds to a solution of fluoric acid in water, if the solution is concentrated. Being simply used for the above purpose, very faintly marked and bright results will be seen, but if powdered, if placed upon the surface of the glass with very finely-divided metal, copal, or other substances resisting the action of the acid for a longer time, and allowing them to dry on after treating them with the acid, there is obtained at once a more or less matted result. The practical advantage of this invention is that the corrosive action being very quickly performed, those parts of the pattern required to be bright need not be covered by any resists whatever. Only feebly resisting substances being required, which would be useless for the ordinary method of procedure, not only all the well-known methods of drawing with a brush, pen, stylers, etc., can be used for putting on the drawing, but impressions of all available methods of mechanical printing, typography, lithography, glass, zinc and copper

plate printing, etc., as well as elastic stamping. Dr. Grune takes advantage of thin and thick resists, using sometimes fine and coarse materials for powdering, obtaining thereby a matted appearance of different density or grain. In a drawing one can therefore obtain different and variegated shadings by the simple use of various materials in the same drawing. In describing the method of working, he divides the process into two parts, firstly, the simple process by which a matted pattern or drawing is put upon the glass; and, secondly, the double process, by which a bright pattern may be reserved upon the glass, the ground-work of the glass being matted or deadened.

Simple Process.—First, I put the drawing upon the object, either by hand, transfer, or direct printing, with almost any oil or varnish mixed with a little color to render it visible. I then powder it by means of a brush or tuft of cotton, or in any other suitable manner, with pulverized metal, copal, or such similar substances. I find what is commercially known as “bronze powder,” very suitable for the purpose. After having dried it, I dip it into fluoric acid, or that may also be put on with a brush, if desirable. After a few seconds, the powder begins to peel off. I then wash it in water. It is not necessary to remove the printing color; the fluoric acid destroying it, it comes off in the water.

Double Process.—First, I paint, draw or print the pattern in a material resisting fluoric acid, such materials being well known. When dry, I oil over the whole surface by means of an ordinary printer's composition roller, with a greasy printing color or oil varnish; powder, treat with acid and wash, as described in the simple process. I then remove the resist pattern, either with an alkaline solution, benzine, alcohol, or like solvent. Instead of applying the acid as a bath, or by a brush, I apply it in the form of fine spray. A very important feature of the invention is that whereas other patterns or designs in vitreous etchings are depressed below the surface, the “deadened” or “matted” portion produced by the above process is raised above the surface. The powdered materials allow the acid to flow between the particles, thus leaving a series of minute spots or holes between each particle, caused by the acid directly attacking the minute uncovered portions, and indirectly attacking the particles forming the resist (leaving them deadened), and thus a series of minute and imperceptible holes or depressions produce the deadened effect. The pattern may be arranged to be bright and incised, while the ground-work is dead and intaglio; or the pattern may be intaglio, and the ground-work bright and incised.

The Clockmaker's Lock-up.

IN A CERTAIN clock factory the workmen have been separated from each other by a wire railing, thus securing their isolation, whereupon one of them relieves his over-burdened soul as follows:

On the verge of despair, tormented with rage,
My pinions I beat 'gainst the bars of my cage.
My case is a hard one, no hope of escape,
My joints all grow rusty, life's mainspring will break.
My movements so screwed up most horribly vex,
And the simplest of actions, seems highly duplex.
Horizontal position there's no room to take,
No lever could raise one so tied to the stake.
What virtue or vice, can a man be inspired in?
Who feels that his body, so closely is wired in?

I crave not for jewels, in settings of gold,
Give me but a cover, to keep out the cold,
A pallet to sleep on, though only of hay,
Some small store of food, where my teeth may have play.
With this quite content, I ne'er would complain,
For freedom brings pleasures and peace in its train.
But pivned up, without room for endshake or play,
The hours glide so slowly each one seems a day.
And I watch full of hope, to end this sad trial,
For old time to strike on eternity's dial.

A. CLOCKMAKER.

Watch Repairing.

BY HERMAN SIEVERT.

II.

The barrel.—This must run free and level upon its arbor. If this be not the case, bush the hole in the barrel cover, and open it again by turning; but the slightest error at the outer rim of the large hole would prevent a good success, since the distance between the two holes is so small. If the hole does not center well, or what is worse yet, that the barrel over the teeth runs untrue, bush both the holes in the following manner: Turn a sink into a brass plate, which, during the whole work remains in the lathe, into which the barrel, together with its teeth, may be pressed. Then open the whole in the barrel first, next that in the opened cover. Both barrel and cover are marked, and when putting them together, be careful to do it by these marks. Now bush both the holes, and for better assurance, open them by turning a little more in the same contrivance, by pressing on the cover without dismounting the barrel from the lathe. A barrel treated in this manner will run very true and flat.

The bottom of the barrel is sufficiently thick with 0.3 mm. Should either it or the walls be unduly heavy, it merely contracts the space for the spring, and they are to be turned out with the graver. If the clamps of the lathe are good, it will not hurt the gilding of the teeth and barrel if they seize over the teeth. If they are in a bad or worn-out condition, it is commendable to lack the barrel upon the previously turned-off face of a plate, and after finishing work to loosen it again by a blow upon the reverse side of the plate. The shellac may be removed by boiling in alcohol. The cover is also generally turned in a little, but it must not be much, since too weak a one is always productive of divers defects, among them, too small a solidity of the shoulder for the stop wheel.

The stopwork is a very essential part of the barrel. It consists of the stop finger or male stop, and the stop wheel or female stop. Its function is to prevent the entire running down as well as the entire winding up of the spring, so that neither the weakest nor the strongest power of the spring is used. Fig. 1, *a* is a correct stop, while *b* and *c*

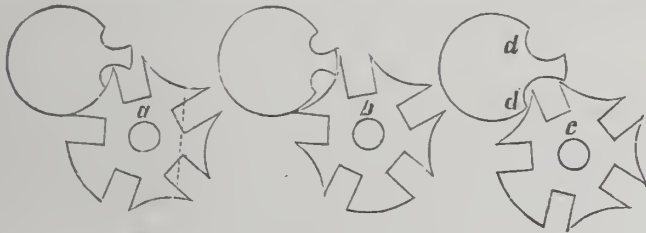

FIG. 1.

represent two faulty ones. The first one has the defect that the finger is too short, and the wheel too far from the center. A bad case is represented in *c*, which becomes serious because it can be noticed only by wearing the watch. The fault lies in that the hollows of the finger are too large or its corners not sharp. Both the outer corners *d* must be thus that a premature turning of the stop wheel cannot take place. A new male stop must unconditionally be made in the present case. For this purpose choose a stop of a little larger diameter, fasten it into a smooth tong, and file the square hole carefully to a fitting size, so that it remains in the center if possible. The outer rim may possibly be turned off upon a turning arbor with aid of a drill bow and sharp graver; a little practice is required for this, since no entire revolution can be made with the stop.

An irregular shaped stop wheel also must be replaced, the countersinking for the screw head can be executed very handsomely only upon the universal lathe, and the wheel is for this purpose either sprung in a countersinking as mentioned above with the barrel, or lacked. Most of the useless stop works have stop wheels with unduly narrow cuts; if the cut is wide, the male stop may also receive a nicely rounded form, without prejudicing its necessary solidity.

If both the male and female stops are good, but too far apart, the stop wheel must either be turned in new in another place of the barrel cover, or, if the old brass shoulders should still be good,

either one or the other are to be replaced by larger ones. When selecting, be sure to observe that they fit well to each other. The diameter of the male stop must be equal to the distance measured across two opposite hollows of the female stop, as is shown at *a* by the dotted line.

The rounding of the finger must be smooth, so that the stop wheel does not catch on any occurring protrusions. The sharp edges of the stop wheel are also to be rounded off with a polishing file. The cut for the pin retaining the finger, must also not be filed in for this reason, but is made with a round fraize in the turning lathe, so that it does not reach to the rim of the finger. A small ratchet wheel turned thin outside and well hardened, is well suited for such a fraize. Both these parts of the stop work are to be hardened and annealed blue.

Fastening and depthing of the barrel wheel.—There are two different kinds of barrels, according to the manner of fastening; the so-called going barrel, provided with a firm ratchet wheel and cone, and barrels with double bridge and loose ratchet wheel. In the former case, the entire portion of the barrel is retained by the bridge and the covering screwed upon it. Should the barrel not stand straight, assist by additional sinking, by turning upon the universal the sink for the ratchet wheel in the bridge, while this is screwed upon the plate; but have a care that the barrel is not lowered too much thereby. The ratchet wheel must, by a going barrel, be retained with soft friction, not sufficiently firm that winding is made difficult thereby. The winding square must have no side shake in the bridge hole so that the depthing into the center wheel is not rendered unsteady by the double shake. The straightening of a barrel with double bridge is effected by turning a hole open, similar as by the center wheel; but first try the depthing, in order to find which of the two remedies, bushing either above or below is most appropriate. But if the depthing is much too shallow, file the hole in the lower bridge toward the appropriate side, and bush this first; afterwards open the upper hole in the universal lathe.

It is a serious fault if the depthing of a going barrel is too shallow. The bridge of such a barrel is generally filed in on account of the click, and has been so much weakened thereby that a bushing would only force it apart. I can only recommend the removal of the bridge in a suitable manner in such a case. It will suffice in most cases to confine this work to one end of the bridge. The holes in the plate for both screw and foot pin are closed by solid screw bushes, and the corresponding places smoothed with a chamferer. After having filed the foot pin from the bridge, the whole, together with the barrel, is screwed upon the plate, and the depthing can then be corrected. As soon as it is in order, a new hole for the screw is drilled first, whereby the hole in the bridge serves as a guide to the drill. The hole for the foot pin is next drilled at a suitable place from the outer side of the plate, through, into the bridge, without perforating it entirely, however. The hole is only made sufficiently deep to effect a secure fastening of the foot pin, so that the outer side of the bridge remains uninjured by the change of depthing.

If the barrel depthing is too deep, it is easily corrected by the repairer, who either has a rounder and cutter, or Ingold fraizes at his disposal. The latter reproduce in an exact manner the correct rounding form of the tooth, while the former can only impart the cycloidal line as rounding form. Still, the Swiss rounding tool is also an exceedingly handy utensil, and especially it cannot be dispensed with in a case when the tooth spaces have to be made either broader or deeper. This case occurs so seldom, however, that the repairer who intends purchasing some such a tool, should purchase the Ingold fraizes without further considerations. As stated already, they finish the tooth not only smooth and in the correct form, so that with its help exceedingly easy depthings are obtained, but they also correct to a certain degree inequalities in the tothing, while the rounding tool only makes them worse.

The placing in height of the barrel is determined by the center wheel and hour wheel. It must neither touch the former nor press

the latter against the dial. It must be noted at the time of taking down the watch, toward what direction this is to be altered, so as to serve for a guide by bushing the holes, etc. It also occurs sometimes that the hour wheel hangs at the points of the stop wheel, and causes the watch to stop. It will be found generally that the stop work is too large for the watch; the defect will only rarely be found as owing to an unduly large minute work.

The minute work.—First examine whether the center staff turns too easily or heavily in the center pinion. Too thin a staff can generally be corrected only by the insertion of a new one. It will commonly be found in new watches that the center staff turns only with difficulty; this is not as it ought to be, and can only be injurious to the watch. Correct it by carefully chamfering the hole in the center pinion, but clean it frequently, so that the dust does not cause you to make a mistake by enlarging the hole too much.

Next try the depthings of the minute work; if they are not so shallow that the teeth set against each other, or so deep that they prevent the free running of the center wheel, they are good. You must not be careless in this examination, however. Any burr in the teeth of the common pinion must be removed by means of a small rounding file, and in the minute pinion with a sharp graver. Any roughness of the wheels is easiest remedied by an emery paper file, which at the same time loosens the burr in the teeth, so that it is easily removed by a brass scratch brush. No pinching of the minute and hour wheel by the dial must occur. The hour wheel should rather have sufficient shake that it may be kept down by a weak stay spring. If this is not the case, either make the wheel thinner or the canon pinion shorter at the toothed end upon the screw head, polishing tool. After being satisfied that the barrel with the minute work can in no manner wedge itself, we arrive at the

Click.—The principles upon which this is constructed have been elucidated heretofore, when treating of clocks. But while nothing hinders in making the click of clocks as large as consistent, we have a different condition of affairs in watches, since the diameter of the ratchet is circumscribed by the center wheel. If parts so small shall remain durably serviceable, compared to a proportionately large power, it is necessary that the click be made with care and from material capable of offering resistance. This is frequently not the case, as is evidenced by the appearance of many a watch, in which the corrections that soon become necessary, and not always executed by the skilful workman, have left, especially in the case of the click, an everlasting monument of botchwork.

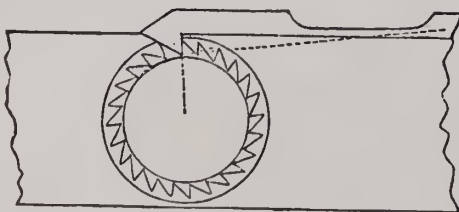

FIG. 2.

Fig. 2 represents a click with simple clickspring. The wheel being the weaker part, one of its tooth points should never alone touch the tooth of the clickspring; the operating part of the latter is rather to be filed in such a manner that the tooth is exposed to the greater pressure upon the bottom, to protect it against breaking. To demonstrate it I have drawn the tangent from the place where the spring is screwed over the bottom circle of the wheel; there where the tangent forms a right angle with the radius of the wheel, the depthing of the clickspring into the wheel must occur. If the spring was shorter, the power of the mainspring imparted to the wheel would soon incline the former to slide out. Undoubtedly, in order to prevent this defect, many a watchmaker has committed the opposite error. The majority of the click springs on close investigation will be found too long. It is apparent that the projection of the spring must seize into the bottom of the teeth in order to have the click-work secure. If this is not the case by too long a click spring, do not

sink it deeper into the bridge, because the defect of the wrong depthing will only be augmented thereby, it is better to set the spring a little back. For this purpose, bush the screw hole on the side of the bridge, and also that of the foot pin, if there be one, with screw bushing. Carefully file next the place for the correct depthing distance for the click spring, and place it, after having removed the foot pin, in case there be one, on the bridge to drill new holes. Having brought the click spring in this manner into its correct position, it will seize sufficiently deep, and the click-work is essentially improved.

The click-work represented in fig. 3 must also be constructed according to the same principles. If the catch is too short, it has

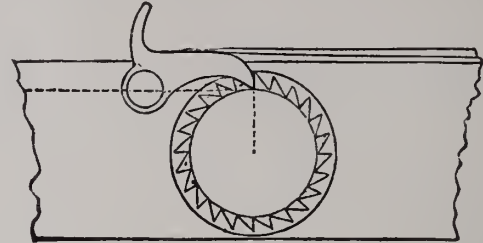

FIG. 3.

as consequence a largely increased pressure and quicker wear; if too long, then the wheel will soon force it out. The most common error, however, is to be found in the faulty support of the catch, which must be of such a description that it prevents the latter from sliding to one side of the wheel. Since this is prevented toward above by the covering, the shoulder which frequently increases the thickness of the catch at its point to the thickness of the bridge, has actually no functions, and it is to be pitied if the bridge is filed in on account of such a shoulder. The sliding of the catch is prevented far more effectually if this is of a uniform thickness, and kept in correct position by a bridge that is not filed in together with the covering. But if such a catch still does not seize sufficiently into the ratchet wheel, it is better to file off the shoulder, instead of still further weakening the bridge. If, after this, the catch does not yet seize sufficiently into the ratchet, the question of necessary strength of the catch does generally not permit the filing away of the material standing in the way. Cutting it out of the bridge with the graver by free hand is a difficult matter, and the gilding can easily be damaged by the sliding of the tool. The graver most appropriately shaped is one ground on only one side, and in shape of a screw-driver, which may be made effective by means of light hammer taps. This graver or punch is carefully to be placed upon the upper part of the bridge, and as much as necessary is chiseled off from it. The chips are removed in the same manner from the sides. It is clear, that click spring as well as catch are to be let in as neatly and clearly as possible into the bridge.

Proceedings of the Horological Club.

A DISTINGUISHED BODY OF WATCH AND CLOCK MAKERS.

One hundred and fifth Discussion.—Communicated by the Secretary.

[NOTICE.—Correspondents should write all letters intended for the Club separate from any other business matters, and headed "Secretary of the Horological Club." Direct the envelope to D. H. Hopkinson, Esq. Write only on one side of the paper, state the points briefly, mail as early as possible, as it must be received here not later than the eighth day of the month, in order to be discussed and reported in the CIRCULAR for the next month.

ELECTRIC CLOCKS.

Secretary of Horological Club:

I herewith enclose to you a description of an electric clock which I have invented, overcoming, as I think, the objections to electric clocks already made. I have had models of all the parts running and they seem to work well. Now I would like to know if, in your opinion, it can be patented, and if so, can it be made of profit to the patentee?

It consists of a pendulum so driven by an electro-magnet as to not be affected by the varying strength of the current, and may be

adjusted or compensated in the usual manner. It can be made to beat seconds or half seconds, as may be desired.

The swinging of the pendulum opens and closes the circuit, so as to make and unmake the magnet at the proper time to give the impulse to the pendulum. A train of wheels (to give motion to the hands) connected with a ratchet moved by an electro-magnet, which in turn is operated by the above pendulum or circuit breaker. The ratchet so constructed as to be positively moved by every vibration of the armature, cannot be moved backward at all, and forward no faster than the motion of the armature will permit, thus keeping the hands right, even if they are exposed to the action of wind and weather.

A striking attachment run from or by the same current, yet not interfering with the motion of the hands, striking the hours from 1 to 12, for house purposes.

As is seen, the whole of the clock is driven by electricity, requiring no winding, and is intended to be used where dials are to be run in places that cannot be reached conveniently for winding, principally for watchmakers' signs over the street, giving the time and making a fine sign.
M. E.

Mr. Electrode replied that many electric clocks have been devised to do all that Mr. E. describes. As he does not tell us *how* he does it, his way may be different, and better than others. If new, it can be patented. There is need for a really good and reliable electric clock for very many purposes, and if one could be made which could be safely depended upon to not fail when most wanted, or be at least as trustworthy as ordinary clocks, there would doubtless be a considerable sale for them. But as we know nothing of the construction of this clock, we can of course only reply in general terms. Many of the best electricians, both living and dead, have worked at this problem, and many electric clocks of different kinds are in use. But up to this time even the most expensive ones require constant watching and care by a competent person, to keep them in good order. The main difficulty seems to be that at the points where contacts are made and broken, the surfaces soon get oxidized by the current, or collect dirt or dust, and the moment that the meeting surfaces fail to have perfect contact the clock fails to operate—either entirely or more or less frequently, according to the nature and extent of the break in the circuit. Mr. E. will find more detailed explanations on these points in our Proceedings for last month.

RUSTY PIVOTS.

Secretary of Horological Club:

I am troubled with a dry rust—sometimes a black scale—forming on the pivots of my watches, particularly on the large pivot of the center wheel, and sometimes a black gummy substance together with rust on the other pivots. I immerse the parts in alcohol when cleaning, leave them in from 15 to 30 minutes. I have changed bottles of oil several times, always using Kelly's, but still have the trouble spoken of. Please advise me how to get rid of it.

Respectfully, J.

Mr. Horologer could only account for the rust on the supposition that something besides oil got on the pivots. It is the practice of some workmen to clean their oiling wire, when using it, by wiping it off between their lips. It is hardly necessary to point out the danger of this custom, by getting moisture with the oil, or even wetting the pivots instead of oiling them. He had seen workmen use the same wire for applying soldering fluid in soft soldering, and afterwards for applying oil to clocks and watches—merely wiping off the wire between the fingers to clean it. It is not at all likely that Mr. J. does anything of that kind, and it is only mentioned to show the difficulty of answering his question without any knowledge of the situation or customs there. If the oiling wire is left lying loose on the bench, it may easily get contaminated with some sort of acid or injurious substance. And the oil box itself is liable to the same danger, especially if left open much of the time. If the metal which sustains the pressure of the pivots is quite thin, the pressure may force the oil out from between the rubbing surfaces, and leave them running practically dry, even when there is plenty of oil in the hole. This is a very common cause of the "cutting" of the center pivots, and is most frequently noticed when the hole has been worn too large and then *punched up* instead of bushed. Only a little of the

metal touches the pivot, which soon rusts and cuts. Jeweled bearings which are too thin for the pressure upon them will act in the same way. Keeping watches in boxes of cedar wood is said to cause the oil to gum up and become thick. Possibly very "pitchy" pine wood, or the vapor of turpentine or other similar substances might have the same effect. In fact, we can only advise Mr. J. to use every precaution he can think of in the hope of curing the evil. Perhaps he has got hold of a poor lot of oil, or old, or not genuine.

MAINSRING BREAKING IN MANY PIECES.

Secretary of Horological Club:

I recently took in a lady's gold watch to have the click spring fastened. Having done that, I wound it up and set it by the regulator. It ran one hour, and the mainspring broke in eleven pieces. The mainspring was size No. 8. The watch was a patent lever, Huguenin, Locle, No. 29,310. Does the Horological Club know of a mainspring breaking in as many or more pieces than this one?

J. S. C.

Mr. Uhrmacher said that it was not uncommon for springs to break in many pieces, both in the watch and while yet in the binding wire as bought. He had known a spring to break in twenty-four pieces. And, what was still more singular, a spring would sometimes break in each coil, and in such a way as to form an opening or passage through all the coils, from the outside to the center, with the broken ends all exactly in line with each other. Mainsprings have many very curious freaks, and Mr. C. will find numerous instances described in our past Proceedings.

SHIP'S COMPASSES.

Secretary of Horological Club:

I am in a seaport town. I have considerable to do with ship's compasses, and I have a good deal of trouble with them. Would any of your honorable body inform me how to repair them, how to magnetize them, and how to adjust or find the variation on iron steamships? Please to inform an old subscriber.

J. M.

Mr. Electrode, to whom the foregoing letter was handed for reply, observing its date, discovered that it had accidentally been overlooked for two months, and to make amends for the oversight he would answer it more fully than would usually be allowable. The form of the magnetic needle is various, sometimes being a long, flat prism, at others being lozenge shaped. At its center a cup, generally of agate, is fixed, in which is formed a cavity, to receive a small steel point, on which it rests, so as to turn freely in obedience to the directive action of the earth's magnetism. Whatever be its form, it is first strongly magnetized. The best method is to place the needle with its ends resting on the opposite poles of two magnets fixed to the bench, then take two other magnets in the hands (the magnets being of equal strength), holding them with opposite poles together, touching the middle of the needle, while their outer ends are slightly inclined upwards from the end of the needle. The two magnets are then simultaneously rubbed along the needle to its ends, and off. The two magnets are then replaced on the middle of the needle, and it is again rubbed. After several passages the needle is turned the other side up and the process is repeated, when it will be magnetized. Of course the poles above the needle are the same as below, at each end, *i. e.*, both magnets have north poles at one end of the needle, etc., so that they strengthen each other. It can be magnetized without the two lower magnets, or even by a single powerful magnet, by rubbing it several times over the middle from one end to the other, always in the same direction. The end *first* touched is of the same polarity as the end of the magnet by which it was rubbed, and *vice versa*. The double magnets are preferable, and make better needles.

When the needle is magnetized, the next point is to find if the magnetic axis of the needle coincides with its axis of form, *i. e.*, if a line drawn through its two poles or strongest magnetic point, coincides with a line connecting its two ends. If not, the indications of the needle will not be correct, for its *poles* may be in the magnetic meridian, while its *points* are pointing to one side of it. This is tested before the needle is fixed in its cap, and is yet removable from

it. An observation is made, and the declination of the needle carefully noted; it is then removed from the cap, turned the other side up, and its position again noted. If the positions differ the needle is not correct—the true position being midway between the two observations—and it should be remagnetized.

Another error may be that the center of gravity of the needle may not coincide with the axis of suspension, in which case the needle will "dip" too much or not so much as it ought. For ordinary compasses this is immaterial, and the needle may be dressed off till the two ends are balanced and remain horizontal. But in an inclination compass this must be corrected, and it is done by carefully noting the inclination, then the poles reversed, by demagnetizing it and then magnetizing it in the contrary direction, and again noting its inclination. The "mean" or middle point of the two observations is the correct one. There are other errors which require correction in some kinds of apparatus, but do not occur in ship's compasses, or are not of sufficient importance there to need any alteration in most cases—such as for the difference in the intensity of the earth's magnetism at different places, and for different hours of the day at the same place, etc.

The "declination" of the needle is its deflection to the east or west of the meridian or true north and south line. Furthermore the declination varies in the same place—gradually, extending over a great number of years, annually and daily, but the variations are small. There are also variations caused by earthquakes, *aurora borealis*, and "magnetic storms." But as Mr. M. will not be called upon to make corrections for these, they need not be dwelt upon.

The greatest difficulty is the variation caused by the magnetism of masses of iron in the vessel. A vertical body of iron, say in the end, would disturb the compass most when the ship was at right angles to the magnetic meridian, while horizontal bodies, as deck beams, etc., would not disturb the needle when the ship was in the magnetic meridian or at right angles to it, but could do so in intermediate positions. Other variations are due to merely local attractions. Various means of correcting those errors have been tried, such as placing magnets or pieces of soft iron near the binnacle in such positions as to neutralize the attraction of the vessel itself, and leave the needle comparatively free. These positions are changed till the compass will, in all positions of the ship, point in the same direction as a standard compass on shore, or on another vessel which does not disturb it. This correction answers very well for vessels running between this country and Europe, but when they have to cross the equator or sail through a considerable change of latitude, it is an actual source of danger, for as the magnetism of the ship varies with the latitude in which it is, it causes a constantly varying deviation of the needle, rendering it impossible to know the real error, and consequently useless as a guide. Two ways have been suggested for remedying this difficulty. One is to place a standard compass at the mast-head, so as to be comparatively free from the attraction of the iron of the ship, and use this to ascertain the errors of the regular compass used by the steersman. Another is to arrange masses of iron to render the attractions of the different parts of the vessel as equal as may be, then swing the ship, and note the deviations of the compass in all positions by taking the bearings of an object on shore or of some star, and compute a table of the errors in the different positions, which can be used for computing the correct declination in subsequent observations. This, he believed, answered Mr. M.'s questions. More detailed information could doubtless be found in works on astronomy and navigation, but he was unable to give the titles of any such, not having any knowledge of a work devoted to the subject. Perhaps some shipmaster could inform him.

Jewelry from the Tombs of Chiriqui.

A VERY remarkable collection of objects in gold and bronze, with vases coming from the old native tombs and burial places of the primitive races who once inhabited Colombia, has been brought to New York by W. W. Randall, Esq., the United States

Consul of Savanilla. Some 25 years ago archæologists became acquainted with a peculiar series of ornaments wrought in gold which had been found at Chiriqui. At one time these Chiriqui ornaments were in such quantity that they were sold in Europe for a very small advance on the value of the gold, but to-day such objects are highly prized and bring very large prices. The present collection, most especially for its metal work, is quite unique of its kind, as it presents types of subjects which have been heretofore quite unknown. The material used for the greater proportion of the objects is gold of great purity, though in some cases an alloy with copper has been employed. In studying first the metallurgy of those early races inhabiting the north-western portions of South America, it becomes quite evident that not only gold must have existed in large quantity, but that the people must have had a great deal of skill in the working of it. In the present condition of this collection, which has not yet been thoroughly classified, it is quite evident that it represents a wide range of time. If some of the objects are of the most primitive character, made in a period long passed away, others exhibit not only a thorough acquaintance with the mechanical purposes of the goldsmith's work, but a very remarkable sense of art, and may be of later date.

Mr. G. L. Feuardent, who has studied the collection, is quite certain that the natives had an acquaintance not only with all the methods of fusing and soldering gold, but were familiar with the art of working in *repoussé*, and that they must have been able to roll out their gold into thin sheets. The absolute similarity of certain pieces which make a necklace or an ornamentation worn over the shoulders shows that the gold plates must have been placed on some form made possibly of hard stone or perhaps of bronze, and on this the precious metal was beaten by hammers into identical shapes. One most remarkable object is a spiral necklace of fine gold, some 2½ feet long, which is made with wonderful skill, it can be compared only as to form with one of those long cuttings of iron or steel which is made to-day when a bar of metal is turned up on a delicately adjusted lathe. The edges of this long spiral are as true as if cut by a perfect mechanical adjustment. As to the rolled pieces of gold, they are of quite large size, and if seen to-day by an expert he could not imagine how they were made otherwise than by having been passed through chilled rollers. One belt of gold is a foot and a half long, and weighs 23 ounces. It is perfectly smooth, of an even thickness, save where the edges have been embossed. Classing this collection, as to form, the objects being very numerous, the larger proportion represent men and women. The art here is exceedingly crude, about the same as would be shown by the baker's apprentice when he models a gingerbread man. A flat piece of gold was cast and hammered and shaped, as to outline, into the head, body, and legs of a man. On this, as would have done a schoolboy to-day, were added eyes, nose, mouth, and the arms were made with thin rods of gold, which were joined to the shoulders and laid flat on the body. You look down on the object and see all the crudeness of it. Here, however, the mechanical excellence of the work is evident. These natives were experts in soldering and filigree work. Of this class of objects there are many hundreds, the difference of the sexes being always shown, though in one figure hermaphroditism is represented. Generally the reverse of these flat images have decorations, and in one case a female figure carries a child on her back. The most wonderful of these images which perhaps were objects of worship, is one of very peculiar form and workmanship, which differs from the rest in many respects. It is of gold about 4 inches high and might weigh a half a pound. It represents a figure of a man within a wicket inclosure. It is built up of gold wire, and is fused together. It is singularly intricate and is quite unlike anything known to archæologists, as far as method of construction goes. As to the manufacture, some South American archæologists who have studied this figure think that the aboriginal race who lived in Colombia had a method of uniting their fine gold dust with some peculiar gum, which, when fused, was dissipated, but, acting as a flux, held together

the particles of metal. What we do know is that the old jewelers of Etruscan times had methods of fluxing the precious metals which we are quite ignorant about to-day. This strange figure stands on a base, apparently made of small nuggets of gold, and there are two or three small human figures at his feet. There is no doubt that it represents the sacrifice of Guesca. According to the old South American rites which tradition has preserved, a young man was taken by the priests, and for 20 moons was cared for. Every wish and desire he expressed he was indulged in. At the expiration of the time when the fatal hour came, he was offered as a holocaust to the God of the Harvest. Mr. Randall informed the gentlemen who were present that in Colombia there was another figure made in the same way, representing a different subject, which weighed six pounds, and that he was hopeful of obtaining it.

In objects of personal ornament Mr. Randall's collection is remarkably rich. Those aboriginal races must have worn ear rings of the most massive character. One ear ornament of solid gold weighs six ounces, and is about as large as a quarter of a pound iron weight. The ear lobe must have been cut and gradually enlarged until big enough to hold this ponderous piece of gold, which is in the form of an exaggerated eyelet. For nose decorations in gold this collection is unequalled. Some are made in two pieces. A hole was cut in the cartilage of the nose, just between the nostrils, and through this one part of the ornament, made with a round piece of gold as thick as a goose-quill, was passed. This was pushed into a hollow tube, the socket of another portion of the same ornament. The whole nose-piece when thus united must have stood across the face of the wearer. Another decoration suspended from the nose must have hung low enough to cover the entire lower part of the face. This is ornamented with birds' heads and birds' beaks, and from it hang many bells. These people wore bracelets of gold, which, in form, closely resemble torques. Many of these are of solid metal, though some few are of bronze covered over very skilfully with gold. There seems to have been a graduation in the size of these bracelets, and perhaps when their comparative weights are better understood some interesting facts might be discovered, which would show that they were representatives of value. Old races, such as the Egyptians, used gold for a medium of exchange, made up in quite similar forms. The old Irish had gold money of this form. There are also a number of nodules of gold which look as if they had been used for money. As an argument tending to show this, Mr. Randall states that pieces of stone have been found, into which these lumps of gold fit, and that their use might be to determine at once their value, though these stones might have been the molds for casting. The earliest currency known, that used in Lydia, resembles these South American pieces of gold, only that the Greeks applied a crude four-sided punch mark to their money.

Such primitive forms of the human figure as are shown in this collection certainly represent the earliest period of art. When, however, the copies of animal forms are examined a considerable amount of progress is shown. There are lizards and frogs of gold, showing a very exact perception of outlines, with a perfect appreciation of the distinguishing traits of such creatures. There are many lizards, with heads true to nature, the scales and peculiar markings having been faithfully copied. All these South American races seem to have given especial attention to frogs, and there are many forms of Batrachians in gold in Mr. Randall's collection. Snakes abound and are very peculiar, and differ in many respects from the accepted serpent. Almost all of them have a peculiar knob on them not far from the tail, the presence of which is unaccountable. There are many pins of gold. One has for ornament a monkey, which has climbed up the pin, and has secured himself by twisting his tail around it. This is exceedingly clever and life-like, and worthy of reproduction. A very pretty ornament represents a plant growing from a pot, with two snakes coiled around it. Mr. Randall states that snakes as household pets are still kept about houses by the Indians of Colombia, and are called

cassadora or hunting snakes because they destroy the small vermin around the houses. There are hook-like forms of gold used, not for fish, but for catching birds. Certain gold disks, possibly suspended around the neck, show great intricacy of pattern and peculiarity of workmanship. The edges of these rounds of gold are invariably carefully finished, having a surrounding of gold filigree. Some of these disks are ear ornaments, and have a spiral gold wire attached to them. The masks of gold are of various sizes, and resemble closely those found at the supposed site of Troas. The material is of fairly thick gold and the features of an archaic type. One mask is of bronze, with a coating of gold, which seems to show that the art of gilding was well known.

From the study of this collection, it becomes more and more evident that the primitive race in South America were familiar with bronze. In quite a number of cases the objects in gold are imitated in bronze. Such specimens of bronze are, however, very rare, and Mr. Randall states that they are more difficult to obtain than those of gold.

In the careful examination of the objects in gold, many of them seem to have been cast with a core, which was afterward dug out. Such particles of core as remain are of great hardness. After casting the object was finished up with such tools, possibly of silex, as the natives possessed. Mr. Randall believes that tools of jade are to be found in the country belonging to the early races.

The source of derivation of these curious objects in gold and bronze is from the country some 75 miles around Bogota, and they were generally taken out of the funeral vases found in the tombs. The ceramic collection of over 1,000 pieces is of the most varied character, and presents many novel features. In color it is white, red, yellow, and black, and in many cases the shapes imitate the human form. The great use of this pottery is to explain the character and purpose of many of the objects in metal, as the figures are decorated with the same ornaments as those actually presented and which exist in the collection.

Very certainly these objects are of exceeding interest, and will furnish material of research for archæologists. Mr. Randall, who has devoted a great many years to the study of these curious subjects, has been fortunate in adding to his own collection that made by a Colombian explorer, Señor Ramos Ruiz. As soon as cases have been made for the reception of these numerous objects, the whole collection will be exhibited in the Metropolitan Museum of Art.

We shall never know, even approximately, what quantity of gold there was in use by the natives when the Spaniards landed in South America, but quite certainly it must have been fairly abundant. To-day, however, such speculations of an El Dorado are secondary to the archæological interest these discoveries awaken.

Advice to Watchmakers' Apprentices.

BY A MAN WHO HAS SPENT TWENTY YEARS AT THE BENCH

FOR THOSE workmen who are located in small towns where it is a long distance to working jewelers, a limited knowledge of how to work the precious metals is indispensable. This work consists principally in making plain gold and silver rings and such articles as can be cut directly from plate metal, or cast by suitable moulds. To this list can be added some of the simpler kinds of goods which are struck by dies. To consider such work in the order named above we will commence with the making of plain rings.

Silver, working much pleasanter than gold, should be selected to commence with. Undoubtedly the simplest way to produce such goods is to cast them somewhat to size, and finish on the lathe; but with gold a considerable loss would accrue. The most practical way is to draw or roll the wire, and wind it on a taper spindle cutting off such pieces as are desired. A draw plate for ring wire is at best not entirely satisfactory, and is now almost universally replaced by grooved rolls; these are heavy and expensive, and not to be thought of by the country jeweler of limited means. The writer had

reason to use such rolls, but their cost made him think twice, and resulted in his making a set which answered in every way as well as the more expensive kind. Having a good strong foot lathe as described early in this series of papers; he made his rolls as follows: He got a piece of good steel (eight-square is generally better than round) one inch in diameter and six inches long; this he annealed in a charcoal box as described also in former article, and proceeded to turn two rolls shaped as shown at fig. 3. The larger part of the roll shown at *A*, fig. 3, was $1\frac{7}{8}$ inches long and the two bearings *a a* were each $\frac{1}{2}$ inch long and $\frac{1}{2}$ an inch in diameter; there was a little friction shoulder about $\frac{1}{32}$ of an inch at each end, as shown at *b b*. These rolls were then turned into grooves as shown in fig. 1, for ring wire. The reader will naturally ask how such a pair of rolls would draw the wire through, as being so small, it would easily slip, and so it would if used with a crank; but the idea was the wire was drawn through by attaching a hand vise, as shown at *G*; to this was fastened a piece of rope which was wound up on the windlass *D*, by the crank *E*. All the parts were fastened to a bench shown at *F*. It is a well-known fact that very frequently 18-k. gold is impossible to

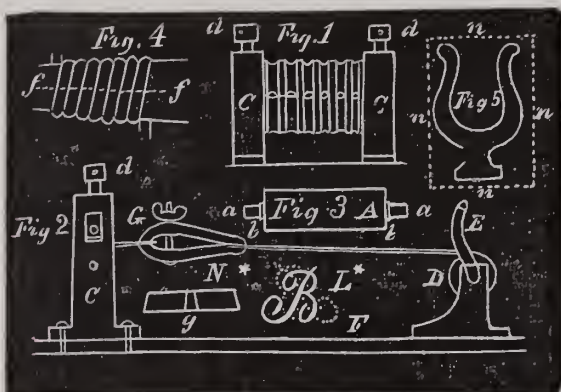

work with a draw plate, and it even cracks in the larger rolls; but in the kind shown, I have drawn wire which would break in wrapping around the spindle.

These rolls are mounted in two cast iron chuck pieces shown at *C*, and have two set up screws shown at *d d*. Silver or gold wire drawn through such rolls and wound on a taper mandril, furnish rings of gradually diminishing size and weight, if sawn on the dotted line *f f*, fig. 4. The ends can now be turned together and soldered; if gold 18-k., you should use 16-k. solder, and no joint should be visible. Coin silver rings can be soldered with the ordinary silver solder. In alloying gold great care should be used to procure perfectly pure copper—old watch dials with the enamel broken off answers about the best. The copper which accumulates in the batteries of telegraph offices is better still. The rolls should be polished in the grooves so as to produce wire perfectly smooth, as the less that is done to a plain ring the better, except to brush and buff it bright.

A pair of plain flat rolls are almost indispensable in any jewelers, and these are best bought out and out; by taking a little time a second-handed set can be obtained generally for about half price. In regard to such articles as are cut directly from sheet metal, the dies for this purpose are double, and known as male and female—one going into the other; they are placed in strong presses and arranged so as to hardly come together, or at best only slightly pass each other, for if they were allowed to come together to any considerable degree, they would soon destroy each other. For this reason screw presses are not the thing—but presses working with an eccentric, which carries the die down just as far every time, are the best. We will first describe the method of making a male and female die, and then give a plan for a cheap and efficient press for such work. Steel for lower discs comes in flat bars of almost all widths and thicknesses, but something about $\frac{1}{2}$ inch thick is quite heavy enough for any jewelry. The steel should be annealed in a charcoal box as described in a former article. Undoubtedly the best way to prepare the steel flat and true for dies is to plane it with an iron planer;

but for a few dies they can be filed flat by using a ground glass slab for a test plate.

After the steel is flat and true, the exact form of the article to be stamped out is drawn on the face of the die. This is usually done by cutting out an exact model of the article to be produced in brass or German silver; this model can be laid on the lower die in the place which it is proposed to cut through, and with a fine sharp steel point trace the outline on the face by following the form as close to the model as possible. The steel die bed is now drilled through in all the forms to be cut out, taking care not to quite touch the outline; the holes can be counter drilled from the back with a larger drill, as all the parts cut through is made larger below, to free the pieces as they are cut out. At *N** is shown the manner in which the recess is enlarged below; *g* shows about the taper allowed. At fig. 5, is shown a lyre, which is supposed to be the model we are trying to produce.

After the lower die is cut through and filed to exactly fit the model, the male or upper die is made. The first step is to harden the lower die, and this is best done by coating the face at and around the lyre-shaped hole which forms the cutting edge of the die, with some anti-scaling compound, or in absence of this, castile soap wet up as a paste. The die should be heated equally throughout in a charcoal fire until a full cherry red, then plunged edgewise in cold oil—lard oil being preferable, but any oil except kerosene will answer—and for a die 2 inches wide, $\frac{1}{2}$ inch thick and 3 inches long, at least 3 pints of oil should be used; this oil can be used over and over for tempering. This die needs no reduction of its hardness. The male die should be of about the same size as the lower one, and have a mortise the size of the dotted line *n, n, n, n*, fig. 5; into this mortise should be fitted a steel plug (also annealed) which protrudes about $\frac{1}{4}$ of an inch. This plug should be firmly driven into the upper die bed and filed off flat with the back.

The model is now laid on the face of this plug (which is supposed to be flat and parallel with the back) and marked around as before—taking care that the reverse side of the model comes next this die, so the work matches. To illustrate, suppose you are making a die to stamp out such initials as are so fashionable, and it was a B you wished to make, as shown at *L**; if the same side of the model was used for each die when they came together, the male die, instead of fitting, would stand as shown at the dotted line. In stamping out such work as the B, shown at *L**, it is not done at one operation, but at two, and sometimes requires three times putting through the press and a change of dies at each going through. All this will be explained in due course. The lower die should now be fastened securely in the press, and the upper or male die, while still soft, placed in; of course it is understood that the upper or male die is filed and fitted very close to fit. The upper die should be filed off on the face until both dies fit perfectly—so much so that they will cut out wet tissue paper. Next month we will give a cut and description of a cheap press, and preface it with the remark that although not elegant, still it will do good work at a tolerable speed.

Marvels of Mechanism.

—In the South Kensington Museum, at London, is a small watch about one hundred years old, representing an apple, the golden case ornamented with grains of pearl.

—The cathedral church, built in Lubeck in the years 1170-1314, has a curious clock. On the end of the hour hand is a little clock which keeps exact time with the large one.

—Millardet, a Swiss mechanic, exhibited in London in the last century a female figure that played eighteen tunes on the piano with all the motions of natural life, the eyes following the movements of the fingers on the keys, the pressure of which produced the notes.

—Oswaldus Nothingerus is said to have made 1,600 dishes of turned ivory, all perfect and complete in every part, yet so thin and

slender that all of them were included at once in a cup turned out of a poppercorn of the common size. They were so small as to be almost invisible to the eye. They were presented to Pope Paul V.

—There is in Turin a tiny boat formed of a single pearl, which form it assumes in swell and concavity. Its sail is of beaten gold, studded with diamonds, and the binnacle light at its prow is a perfect ruby. An emerald serves as its rudder and its stand is a slab of ivory. It weighs less than half an ounce; its price is \$5,000.

—Haroun al Raschid, the principal hero of the "Arabian Nights Entertainments," sent to Charlemagne, in the eighth century, a water clock, in the dial of which a door opened at each hour, and when at noon the twelve doors were thrown open, as many knights on horseback issued forth, paraded round the dial, and then returning, shut themselves in again.

—A number of years ago Henry Clay was presented with a cane. The staff is of live oak, cut from a tree that overshadowed the tomb of Cicero, and the head is made of verd antique, obtained from the house of Columbus, at Genoa. It is octagonal, and ornamented with exquisite medallions of those two famous orators of ancient and modern times—Rome's Cicero and America's Clay.

—A curious purchase has recently been made for one of the Paris museums. It is a confessional of old Florentine carving. Besides the marvelous work on the panels, it is surmounted by the head of the Saviour, which, on touching a spring, disappears and gives place to a diabolical visage, with horns and tongues of fire, well calculated to strike a healthy terror into the minds of penitents.

—There is a watch in a Swiss museum only three-sixteenths of an inch in diameter inserted in the top of a pencil case. Its little dial not only indicates hours, minutes and seconds, but also days of the month. It is a relic of the time when watches were inserted in snuff-boxes, shirt studs and finger-rings. Some were fantastic—oval, octangular, cruciform, or in the shape of pearls, tulips, etc.

—In 1578 Mark Scalliot, a blacksmith of London, made "for exhibition and trial of skill, one lock of iron, steel and brass, all of which, together with a pipe-key to it, weighed but one grain of gold." He also made a chain of gold, consisting of forty-three links, and having fastened to this the before-mentioned lock and key, he put the chain about the neck of a flea, which drew them all with ease. All these together—lock and key, chain and flea—weighed only one grain and a half.

—Queen Victoria is in the possession of a curious needle. It was made at the celebrated manufactory at Redditch and represents the column of Trajan in miniature. This well-known Roman column is adorned with numerous scenes in sculpture, which immortalize Trajan's heroic actions in war. On this diminutive needle scenes in the life of Queen Victoria are represented in relief, but so finely cut and so small that it requires a magnifying glass to see them. The Victoria needle can, moreover, be opened; it contains a number of needles of smaller size, which are equally adorned with scenes in relief.

—A celebrated old manuscript waxes enthusiastic on "The German Masterpiece," to quote verbatim, "being that famous knife, which hath been for some time in England and highly applauded by the most exquisite artists; containing in the handle sixty odd several figures, some engraved, others carved, and all in the admiration of those that beheld them. It hath two keys, which open seven locks, including those various Rarities contained therein; it was seven years a-making, and valued by the author, the famous artist of Germany, at Fifteen Hundred Pounds, and is now exposed to publique view for England's satisfaction. To be seen at Bartholomew Faire, against the King's Head."

Inserting a Tooth into a Wheel.

THERE is considerable dispute among watchmakers, especially those of the better class, whether anything pertaining to a watch train should be soldered. Some maintain that such a practice should be entirely discarded from the art horological, and permit nothing but riveting, while others defend it by saying that there are times when soldering is permissible. There are wheels for which this riveting is far the worst method. For instance, the third wheel requires a new tooth, or, in fact, any other wheel with bars; if we try to rivet it in, the result will frequently be that the depth of the wheel is out of true, and in most cases pitches too deep into its pinion when that part of the wheel gets round, owing to the bulging of the wheel by riveting; it is a difficult matter to rivet a tooth with-

out getting it bulged somewhat, if the wheel is of a light construction. It might be suggested that it could be corrected by placing it in the turns and truing it again, which is true enough, but it should be remembered that this truing and rounding up is a very delicate job to perform, and there is every probability to anticipate that the proper shape of all the teeth may be ruined, and, in case the teeth run deep, the bottom part of their cuts may come into contact with the rounding of the pinion leaves.

This accident may not be sufficient to cause the standing still of the watch, still it may be enough to provoke a slight "stoppage," I have seen watches with a complaint of this nature, which caused the workman infinite vexation; for, as a rule, the watch will start again as soon as the case is opened, the least motion starting it again. It is well known to repairers that such "slight stoppages are very troublesome to repair.

By using solder we retain the proper true of the wheel, and it becomes doubtful as soon as we resort to riveting. We should always be careful to get the new tooth to fit the place prepared for it, because the solder will then not be so likely to get loosened. When the tooth has been secured, we proceed by filing its back part the same shape as the other teeth. As soon as the tooth is cut roughly, place it on the pencilled sketch, with the tooth each side of the new one on the two outer teeth of the sketch; the exact place is then seen where the middle, or new tooth, has to be filed to make it fit the sketch properly. If the pencil marks are properly adhered to, the labor of truing the wheel in the turns is saved, and for this reason the pencil sketch is advisable.

It happens frequently that the other teeth, which do not require topping, are treated thus, nevertheless, and the unnecessary trouble of filing them up again is entailed thereby, which often causes the wheel to be put out of its proper shape, it being an easier matter for the novice to do a job wrong than right.

The teeth of other wheels can be put in the same way, but with these it is best to undercut or dovetail the tooth on both sides, as it has the effect of making the new tooth more solid, and as a rule a very neat job can be made of the tooth when put in, if all the burr and solder is stoned off so that nothing but the tooth is seen. There are those who would not put a tooth into a wheel under any consideration, but the majority of repairers are doubtlessly well convinced that it is an easier job than fitting in a new wheel, not to mention the trouble to country watchmakers, in getting a wheel of the exact size. And it is well in place here to reprove the city watchmaker, when he sees a piece of work not quite up to the mark, done by a country watchmaker. Perhaps, if the former were placed in like circumstances, he would not do as well. Not all the country watchmakers are botches, and it is surprising sometimes what ingenuity they exhibit to overcome grave difficulties.

A Beneficent Act.

THE FOLLOWING letter from Isaac M. Miller, donating to the Jewelers' League the benefits that will accrue to his membership in the future, is one that is not only complimentary to the League, but is an example of the well-known benevolence of Mr. Miller. While the benefit eventually to accrue to the League will be a substantial one, and one duly appreciated, we sincerely hope that a long life of usefulness vouchsafed to Mr. Miller may delay for many years the fulfilment of his benevolent intentions.

COPY.

GILBERT T. WOGLOM, ESQ.,

President of the Jewelers' League.

DEAR SIR—As a member of the League I desire to express to you my admiration of its beneficent operations, by which, when the head and support of a family is removed by death, prompt and efficient aid is brought to the widow and fatherless; and as I would like to see the power of the League for good still further extended, by establishing a fund so that those of our craft who may fall victims to sickness and other misfortunes, may, during their lifetime, receive needed help, I, with that object in view and to that end, herewith hand you a paper duly executed, making such fund my beneficiary. Should a few of our fellow members unite in this object, it would, at no distant day, form a very respectable sum of money, and would draw to itself aid from other charitable sources. With my best wishes that the present success of the Jewelers' League may be increased, continued and perpetuated, I am,

Yours very truly,
(Signed) ISAAC M. MILLER.

Workshop Notes.

MOLDING METALS.—Plaster of Paris is made hard enough for a mold for metal castings by the use of ten per cent. of alum in the water used for mixing the plaster.

REMOVING GOLD.—Gold is taken from the surface of silver by spreading over it a paste made of pulverized sal ammoniac with aquafortis, and heating it till the matter smokes and is nearly dry, when the gold may be separated by rubbing it with a scratchbrush.

CEMENT FOR GLASS AND METALS.—Brass letters may be securely fastened on glass windows by the following recipe: Litharge, 2 parts; white lead, 1 part; boiled linseed oil, 3 parts; gum copal, 1 part. Mixed just before using, this forms a quickly drying and secure cement.

TOOLS RUSTING.—The rusting of bright steel tools is due to the precipitation of moisture from the air. It may be obviated by keeping the air surrounding the goods dry. A saucer of powdered quicklime in an ordinary showcase will usually suffice to prevent rusting of cutlery exhibited therein.

VALUABLE TEST.—The French Academy gives the following test for distinguishing false gems from diamonds. If the point of a needle or small hole in a card, when seen through the stone, appears double, the stone is not a diamond. All colorless gems, with the exception of the diamond, causes double refraction.

REFINING SWEEPINGS.—The sweepings of the workshop contain quite a quantity of gold and silver. To 8 ozs. of the dirt, which has been washed and burnt, add salt, 4 ozs; pearl ash, 4 ozs; red tartar, 1 oz; saltpeter, $\frac{1}{2}$ oz.; mix thoroughly in a mortar, melt in a crucible and dissolve out the precious metals in a button.

A DEFECT.—Always examine the pendulum wire at the point where the loop of the fork works over it. You will generally notice a small notch, or at least a rough place worn there. Dress it out perfectly smooth, or your clock will not be likely to work well. Small as this defect may seem, it stops a large number of clocks.

CLEANING SILVERWARE.—According to Professor Davenport, hypo-sulphurous soda is the simplest and best cleansing agent for silverware. It operates quickly, is cheap, and has not yet been proposed for the purpose. A rag or brush moistened with the saturated solution of the salt cleans, without the use of cleaning powder, strongly oxidized silver surfaces within a few seconds.

JEWELERS' AMERICAN CEMENT.—Isinglass soaked in water and dissolved in spirit, 2 oz. (thick); dissolve in this 10 grains of very pale gum ammonia (in tears), by rubbing them together; then add 6 large tears of gum mastic, dissolved in the least possible quantity of rectified spirits. When carefully prepared, this cement resists moisture and dries colorless. Keep in a closely stopped vial.

MELTING AND REFINING.—In melting brass gold urge the fire to a great heat and stir the metal with the long stem of a tobacco pipe, to prevent honey-combing. If steel or iron filings get into gold while melting, throw in a piece of sandiver the size of a common nut; it will attract the iron or steel from the gold into the flux, or, sublimate of mercury will destroy the iron or steel. To cause gold to roll well, melt with a good heat, add a tablespoonful of sal ammoniac and charcoal, equal quantities, both pulverized, stir up well, put on the cover for two minutes, and pour.

RECOVERING GOLD FROM COLORING BATH.—Dissolve a handful of sulphate of iron in boiling water, and add it to your "color" water; it precipitates the small particles of gold. Now draw off the water, being very careful not to disturb the auriferous sediment at the bottom. You will now proceed to wash the sediment from all trace of acid with plenty of boiling water; it will require three or four separate washings, with sufficient time between each to allow the water to cool and the sediment to settle, before passing off the water. Then dry in an iron vessel by the fire and finally fuse in a covered skittle pot with a flux.

GLASS COATING ON METALS.—The following method has been suggested for coating metal surfaces with glass. Take about 125 parts by weight of ordinary flint glass fragments, 20 parts of carbonate of soda, and 12 parts of boracic acid, and melt. Pour the fused mass out on some cold surface, as of stone or metal, and pulverize when cooled off. Make a mixture of this powder with silicate of soda (water-glass) of 50° B. With this, coat the metal to be glazed and heat in a muffle or other furnace until it has fused. This coating is said to adhere very firmly to steel or iron.

FUSING GOLD DUST.—Use such a crucible as is generally used for melting brass; heat very hot, then add your gold dust mixed with powdered borax. After a while a scum or slag will rise to the surface, which may be thickened by the addition of a little lime or bone ash. If the dust contains any of the more oxidizable metals, add a little saltpeter, skim off the slag or scum very carefully; when melted grasp the crucible with strong iron tongs, and pour immediately into cast iron molds, slightly greased. The slag and crucible may be afterward pulverized, and the auriferous matter recovered from the mass by cupellating by means of lead.

TO CLEAN BRASS.—The method prescribed for cleaning brass, and in use in all the U. S. arsenals, is claimed to be the best in the world. The plan is to make a mixture of one part common nitric acid and one-half part sulphuric acid in a stone jar, having also ready a pail of fresh water and a box of sawdust. The articles to be treated are dipped into the acid, then thrown into the water, and finally rubbed with sawdust. This immediately changes them to a brilliant color. If the brass has become greasy, it is first dipped in a strong solution of potash and soda in warm water; this cuts the grease, so that the acid has free power to act.

ARTIFICIAL GOLD.—A metallic alloy, at present very extensively used in France as a substitute for gold, is composed of: Pure copper, 100 parts; zinc, or preferably, tin, 17 parts; magnesia, 6 parts; sal ammoniac, from 3 to 6 parts; quicklime $\frac{1}{8}$ part; tartar of commerce, 9 parts. Are mixed as follows: The copper is first melted, and the magnesia, sal ammoniac, lime and tartar are then added separately and by degrees, in the form of powder; the whole is now briskly stirred for about one-half hour, so as to mix thoroughly, and when the zinc is added in small grains by throwing it on the surface and stirring till it is entirely fused; the crucible is then covered and fusion maintained for about 35 minutes. The surface is then skimmed and the alloy ready for coating. It has a fine grain, is malleable, and takes a splendid polish. It does not corrode readily, and is an excellent substitute for gold for many purposes. When tarnished, its brilliancy can be restored by a little acidulated water. If tin be employed instead of zinc, the alloy will be more brilliant. It is very much used in France, and must ultimately become popular here.

ARTIFICIAL GLASS.—The following formulæ are used in Bohemia for making imitations of some of the precious gems: *Agate*.—10 kilos quartz, 17 kilos red lead, 3.2 kilos potash, 2.2 kilos borax, 0.1 kilo arsenic. The quantity of chloride of gold added is equal to that obtained from 0.4 of a ducat. *Agate glass*.—10 parts broken glass is melted, and to it are added 0.15 parts suboxide of copper, the same quantity of the oxides of chromium and of manganese, 0.02 part each of oxide of cobalt and nitrate of silver, 0.01 oxide of uranium, 0.4 red argols, 0.3 part bone meal. Each oxide is added alone, and at intervals of 10 minutes. After heating for an hour, 0.3 or 0.4 part of fine soot is put in. *Red marble*.—80 parts sand, 40 of potash, 10 of lime, 2 of table salt, 1 of saltpeter, and 0.1 of arsenic. The mixture is melted, and then 25 parts of suboxide of copper and 1 part of saltpeter mixed in. *Artificial turquoises* are made in Paris and Vienna from phosphate of alumina and phosphate of copper mixed together and subjected to hydraulic pressure. Even in chemical composition it resembles the natural mineral, which is a hydrated phosphate of alumina with 2 per cent. oxide of copper.

Trade Gossip.

Spiders of oxidized silver are stylishly worn as lace pins.

Celluloid show cases are rapidly growing in public favor.

Diamond combs for the hair is the latest fashionable edict.

Link bracelets, made of graduated cubes of gold, are quite stylish.

A. W. Kippling was married recently to Miss J. B. Schindler, of this city.

F. L. Martin, of Samuel Eichberg, arrived from Europe in the *Celtic* Feb. 21.

The Jewelers' League of the State of Texas will hold their first annual meeting early in April.

The favorite finger rings for gentlemen at present are the sard, onyx and chrysoprase in intaglio.

Hart Bros., Brooklyn jewelers, have dissolved partnership, James H. Hart continuing the business.

C. F. Wood & Co., of Toledo, have moved to Detroit, where they will continue the jewelry business.

The firm of Sillcocks & Cooley, after twenty years of active business, has been dissolved by mutual consent.

Isaac Harrison has made an engagement with Messrs. R. & L. Friedlander, and will represent them on the road.

Leopold Weil & Co. will remove May 1st to No. 35 Maiden Lane, over the store occupied by Oppenheimer Bros. & Veith.

The recent fire in Buffalo injured the stock of Heintz Bros. to the extent of \$8,000, which is said to be covered by insurance.

Leopold Weil will parade to wedding march music March 7th. The bride elect is Miss Gertrude Luckermann of this city.

The Meriden Silver Plate Company have in press a very neat and attractive catalogue, which will appear during the present month.

Shirt studs in the shape of a horse are now stylish. They should be worn only by the sports who will never cease sowing their wild oats.

Little wall brackets are entirely covered with plush and decorated with brass nails and the crescent ornaments to which allusion has been made.

Traitel Bros., manufacturers of rings, have leased a portion of the premises No. 40 Maiden Lane, which they will occupy during the month of March.

From the number of arrests of sneak thieves reported in the daily papers, these gentry appear to be remarkably active among the retail jewelry stores of this city.

The thieves who recently robbed a jewelry store at Council Bluffs, Iowa, are reported to have been captured with some of the stolen property in their possession.

Sea shells are mounted on terra cotta plaques. Figures carved in terra cotta peer over the edge of the shells, and appear as if perfectly at home in their curious tenement.

Myers & Finch, the enterprising jewelers of St. Paul, have issued a very neat and handsome catalogue of goods kept by them, embracing almost every style and variety.

The women have taken a fancy to terra cotta, and the *Louisville Courier-Journal* is mean enough to say that it has long been supposed that all they wanted was the earth.

Wm. H. Sheaffer & Co., of Philadelphia, will make their business headquarters at No. 15 John street, N. Y. Their manufacturing business will still be conducted in Philadelphia.

The firm of Bingham, Walk & Mahew, of Indianapolis, has been dissolved, J. N. Mahew retiring. The business will hereafter be continued under the firm name of Bingham & Walk.

Ludwig Lehmann, who was recently burned out in Fulton street, is now temporarily located at No. 283 Pearl street. He is now in position once more to fill all orders with his customary promptness.

An attempt was made to smuggle a diamond ring in a Bible, it is said. The jewel was found. There are other gems—of thought—in this book, which are not so readily discovered or even sought.

Messrs. James Kneen of Birmingham, and Wellington M. Reed, of Huntington, Conn., have patented an improved escapement mechanism for watches. This invention relates to the ruby pin tables of watches, with the object to allow adjustment of the tables and hair spring of the balance wheels without removal, as is required when the wheel and table are attached permanently to the pivot shaft. The parts can be readily adjusted in relation to each other on the staff.

James T. Scott, Jr. was married on Tuesday evening, February 6, at St. James' Church, Brooklyn, to Miss Grace Peterman, of that city. The happy pair immediately started for the West on a bridal tour.

The firm of Ripley, Howland & Co. having terminated by the death of Mr. Howland. The Ripley Howland Manufacturing Company has been organized, and will continue the business of the old house.

Ludwig, the enterprising jeweler of Harrisburg, Pa., is to be the happy possessor of the Waltham movement No. 2,000,000, recently finished at the company's factory, and alluded to in our issue of last month.

A very beautiful candelabra with crystal pendants has a stem of Mexican onyx and branches of the same material. Bands of cloissoné give it an exquisite finish, and the shades are of delicately tinted glass.

A masterpiece in bronze ordered for an English gentleman incloses a clock. The design represents a Christian expounding the Gospel to a Saracen; this piece is flanked by two Saracen figures armed *cap à pie*.

The latest agony in scarf pins is called "The Freddie," and creates much amusement among club men. It is composed of a little gold donkey drawing a cart containing a dictionary and an English grammar.

The rage for tambourines may be supposed to be dying out, but unfortunately this absurd fashion is likely to be closely followed by a still more ridiculous adaptation of guitars and violins to purposes of decoration.

The handsomest punch-bowls are of Austrian glass, some are round and shallow, others in trefoil shape, and others, again, high and coned. A tray and glasses accompany them. Favorite colors are amber, sea-green, or pale blue.

A plaque recently painted by a lady in New York is scarcely distinguishable from Limoges ware. Upon the old blue background water lilies with brown leaves are strongly and effectively outlined, and the finish is particularly good.

Fans, with bronze sticks fourteen inches in length and measuring twenty-nine inches from tip to tip when spread, are hand painted, and instead of one spray the whole fan is entirely covered with gorgeous flowers without a particle of foliage.

In an old New York City directory appears the name of J. Vonderblinkensloffenheisen, a jeweler and silversmith doing business in Whitehall street. Fortunately for his many friends, he was called away before the telephone was invented.

Adam Fisher, of Greensburg, Pa., has had a very successful auction sale under the management of Col. Rutherford, the well-known jewelry auctioneer. The Colonel is now airing his eloquence in the jewelry store of C. & S. A. Baker, at Albany.

A. W. Tenney's jewelry store at Council Bluffs, Iowa, was broken open on the evening of the 9th ult., while the proprietor was at supper, and robbed of 61 watches. The building was locked, but the thieves pried off the staples of the door of a rear room.

The firm of William Smith & Co., manufacturers of gold chain, have been dissolved, John Smith and Otto C. Lenz retiring. The two sons of William Smith have been given an interest in the business, and the firm will be continued under the old name.

The creditors of N. M. Shepard, who some time since made an assignment for the alleged benefit of his creditors, are not inclined to accept his offer. The peculiar circumstances attending his failure seem to warrant the fullest scrutiny into the matter of preferences.

I. Weisbauer has devised an exceedingly convenient cabinet for jewelers' cards and tags. It contains several trays, properly divided into convenient spaces for cards of various sizes. A glance at their advertisement will convey an intelligent idea of its practical convenience.

The Derby Silver Co., of Birmingham, Conn., have just issued a sumptuous catalogue of designs showing a vast number of well executed illustrations of their wares. Copies of this work will be forwarded to applicants strictly engaged in the jewelry business on receipt of proper credentials.

Terence McDonald, a jeweler of Jersey City, was recently arraigned at the Tombs Police Court to answer a charge of larceny. On the 3d ult. the accused, as alleged, by false representations, obtained a pair of diamond earrings valued at \$475 from Otis Anderson, a diamond broker of 4 John street. The accused was held for examination and gave bail.

One good point made in Congress is the omission from the District of Columbia bill of the \$200 tax clause, relating to Commercial Travelers. This makes Washington a free town. Thanks very largely to Messrs. Skinner of New York, Brewer of New Jersey, and others.—*Commercial Traveler*.

Silver dog collars are revived. These are intended to be worn outside the collar of the dress, clasping it closely. Some of these are so arranged as to be separated into a pair of bracelets. The designs are in the scales and chain mail seen in armor, fastened with gadlings such as are seen on steel gauntlets.

L. G. Addor, of Sedalia, Mo., was robbed by burglars on the afternoon of January 27. The thieves secured twenty-three gold and silver watches, a tray full of fine rings, and other articles amounting in the aggregate to about \$1,500. He is one of the best workmen in the state, and the loss falls heavily upon him.

The latest novelty in the mountings of fans is exceedingly pretty, consisting of ivory, tinged a delicate and lovely pink by some new process. This colored ivory has a warm yet delicate hue, with a light tinge of yellow (due probably to the natural cream color of the ivory), which resembles the heart of a tea rose.

Messrs. Heller & Bardel have just completed the most elegant watch case ever produced in this city. The back is composed of diamonds, rubies and sapphires, set alternately, in a neat and artistic manner. The stones are of a superior quality, and are all brilliants. It is a unique, and, necessarily, a costly article.

The old clock in Trinity steeple is dying of old age, and as an accurate time-keeper has lost its grip. When the hands point to quarter past nine and the clock strikes two, then the brokers in Wall street know it is just five minutes past eleven. This horological antique is an excellent example of the art if one understands the basis on which it operates.

Robbins & Appleton announce the publication of a revised price list, and desire the strict co-operation of the trade to keep it in the hands of legitimate dealers. They will exercise the greatest precaution to confine its circulation exclusively to dealers in watches. Copies will be sent only to those who apply for it and furnish satisfactory evidence of being in the trade.

The jewelry store of Stephen Thomas, Jr. & Bro., Charleston, S. C., was recently entered by burglars, who forced open the safe and got away with jewelry the value of which is estimated at \$16,000. Much sympathy was expressed for Mr. Thomas, who came to New York and made known to his creditors his severe loss. They at once accepted his terms of settlement, and he returned home with a replenished stock.

Quiz accuses Queen Victoria of having once upon a time perpetrated a pun. This is how the atrocity was committed: She was studying Roman history with the Duchess of Northumberland, and came to the well-known incident of the mother of the Gracchi and her offspring, finishing with the inevitable, "These are my jewels!" The little princess looked up, and exclaimed: "Jewels? No! I think, they must have been 'Cornelians!'"

A pair of Sevres vases valued at \$6,500 are exactly copied from a pair ordered for Queen Victoria's birthday. They are mounted upon a pedestal of Mexican onyx, decorated in French bronze. The vases are surmounted by a crown of flowers in bronze, of rare workmanship, and have handles of the same rich material. Upon a groundwork of old blue enamel, the design represents upon the one Venus rising from the sea, and upon the other the fable of Europa.

Speaking of the Metropolitan Art Museum, a correspondent of the *Buffalo Courier* says: "The great usefulness of the Museum lies in its training school for artisans. Silversmiths, workers in bronze, precious metals and stones, fresco painters, modelers and designers in all decorative and industrial arts, are put through a thorough course of good artistic study, the results of which will show in our furniture, house decoration, bric-a-brac and architecture at a later day."

Several recent robberies that have been perpetrated upon jewelers in the South, indicate that a gang of burglars are traveling through that section with a special view of raiding on the jewelry stores. The matter has attracted the attention of the Jewelers' Protective Union, and a circular has been issued warning the trade to be watchful, and to use extra caution in watching and guarding their property. Jewelers should make such arrangements that a trusty man shall sleep on the premises every night, and the proprietor himself should be on the alert at all times. Jewelry stores always present a special temptation to thieves and burglars, and these individuals have recently shown great activity in committing their depredations. "Eternal vigilance is the price of safety" as well for a stock of jewelry as for the liberty of a nation.

An improved hand vise for brooch pins has been patented by Mr. Myer Moss, of Yarmouth, Nova Scotia, Canada. This invention relates to a tool used in repairing brooches and similar small articles. The tool is provided with jaws to grip and hold the article to be mended, with a series of graduations for regulating the required length of the joint of the brooch being repaired.

One of the most exquisite pieces of bronze in this city is a copy of Luigi's marble representing Traste Verena, a woman of an early race living on the banks of the Tiber, Amazonian in size. It is wonderfully finished in point of color, every detail of the appointments of dress being in appropriate tint, the ornaments for the hair, comb, necklace and earrings being in silver, and the braid upon the corsage of gold representing a turned-back lapel. At the base of the bust lies, amid dark green foliage, a lyre, the strings of which are in silver.

An assignment for the benefit of creditors has been filed in the County Clerk's office by Lucien Jacquin to Willard Bullard, with preferences as follows: Moore, Clarke & Co., \$875; M. Fox & Co., \$11,422.47; Edward P. Fox, \$1,318, and Amasa Spring, \$8,844.96; total, \$22,460.43. Jacquin was a jeweler at No. 872 Broadway. The preferences to M. Fox & Co. and Amasa Spring are for the proceeds of diamonds and silverware, respectively consigned by them to Jacquin. Much dissatisfaction is expressed at these preferences, as they absorb nearly or quite all the assets. The outlook for the general creditors is not at all cheerful.

At a recent meeting of the Alumni at Cooper Institute, an interesting paper was read by Ernest Kaltenbach on "Jewels and Jewelry," tracing the history of those ornaments from the use of shells to the decorations of to-day. The essayist thought an artistic revival had been developing within the last twenty years that will result eventually in giving better work to the country. New York and Newark, N. J., he said, were the oldest manufacturing points for jewelry in the United States, and made nine-tenths of this work. Maiden Lane contained a larger assortment of diamonds than any other thoroughfare in the world. They could be purchased of dealers there cheaper than in Europe.

In the latter part of December it chanced that several representatives of New York diamond houses met at the Palmer House in Chicago, entirely by accident. The weather was bad most of the time, so that they were confined to the hotel considerably. It chanced that A. F. Veith had a large pleasant room on the first floor, which the "boys" made their headquarters. They smoked Veith's cigars, drank his lemonade, lounged on his bed, and generally made themselves at home. Veith's good nature was equal to the emergency, and his hospitality knew no limit. Finally the exigencies of business dissolved the jovial party, and after some wandering they reached New York again. It then occurred to them that it would be a proper thing to make some recognition of the hospitality they had received from Mr. Veith, so a beautifully engrossed set of resolutions was prepared, with a photograph of Mr. Veith in the center, and signed by the following named gentlemen: William Ellinger, S. H. Levy, W. M. Weil, Fred. Roth, L. Adler, N. Marx, J. Hammerschlag, and A. Pinner. The whole is handsomely framed, and was presented to Mr. Veith with due formality.

James H. Fleming, manager of the case department of Muhr's Sons, of Philadelphia, while stopping at the Palmer House, Chicago, was robbed by a sneak thief, who got into his room and made off with some \$220 in cash and his watch and chain. The thief made off when the alarm was given, encountering two watchmen in the hall, who, being frightened when he presented a pistol, permitted him to escape. On making known his loss to the proprietors of the hotel, they refunded the money. Subsequently the thief was caught, and, with a view to obtaining a light sentence, represented that Mr. Fleming had overstated his loss. This insinuation against Mr. Fleming's integrity was taken up by the papers, which printed a scurrilous article regarding Mr. Fleming, which was shown him on his return to New York. He immediately returned to Chicago to find the author of it and obtain vindication. The papers having done him all the injury possible by publishing the statement of a confessed thief to the prejudice of a reputable business man, no retraction they can make will repair the injury inflicted upon him. The hotel proprietors repudiated all responsibility for the damaging statement, and it finally appeared that the insinuations of the sneak thief had been embellished by the local reporters, whose imaginations were evidently stimulated by a liberal allowance of bad whisky. Being unable to fix the responsibility for the publication upon any person of standing or reputation, he was compelled to be content with a full and complete retraction made by the papers that had published the statement, which was made without reservation.



THE JEWELERS' CIRCULAR AND HOROLOGICAL REVIEW

*The recognized organ of the Trade, and the official representative of the
Jewelers' League.*

A Monthly Journal devoted to the interests of Watchmakers, Jewelers, Silver-
smiths, Electro-plate Manufacturers, and those engaged in the
kindred branches of art industry.

SUBSCRIPTION:

To All Parts of the United States and Canada,
\$2.00 Per Annum; Postage paid.

To Great Britain, France, Switzerland, Germany, the West Indies, Mexico, the
Republics of South America, and Australia, \$3.00 per annum. Postage paid.

*All communications should be addressed to D. H. HOPKINSON, 42 Nassau
Street, New York. Advertising rates made known on application.*

Retail Dealers.

WE HAVE lately received several complaints from retail dealers in the west to the effect that a certain class of jobbers are again sending catalogues and price lists to persons outside the trade, and offering to sell goods at retail at jobbers' prices. One of them relates an instance of a lady coming to him with a catalogue and price list, and wanting him to sell her a pair of bracelets for the exact sum he had paid the jobber for them, and when he declined the transaction, she departed with the undoubted idea that he was an extortionist. Cases of this kind were formerly of frequent occurrence, but the decided action taken by the state associations put a check to it for a time. This practice was the outgrowth of hard times and an overstocked market, when jobbers found themselves loaded up with goods they were glad to get rid of to anyone. Orders came in but slowly from the retail trade, so these hard-pushed jobbers sought to work up a retail trade of their own. They cared nothing for the extent to which they carried demoralization and ruin into the ranks of the retail dealers, so they could serve their own selfish ends in working off their superfluous stock. It required vigorous measures and united action on the part of the retailers to put a check to it, and if it is now being again resorted to by unscrupulous jobbers, measures even more summary should be adopted to punish them. Any jobber detected in sending catalogues and price lists to persons outside of the trade should be tabooed by the entire retail trade, and we have no doubt he would lose the greater number of his patrons if the facts were made known. When a retail dealer detects a jobbing house doing this dirty work, he should at once notify every one of the state associations and all his neighbors, so that they may avoid such jobber in the future. There is no stringency in general business to give even the shadow of an excuse for such unbusinesslike practices, and those who indulge in them do so simply to cater to their own selfish greed.

The retailers constitute the foundation upon which the prosperity of the trade is built, and they should be protected in their rights. They are the ones who come in direct contact with the consumers, and are the ones whom manufacturers and jobbers must always depend upon to sell their goods. When a jobber or manufacturer solicits a retail trade at wholesale prices, he is robbing the retailer of patronage that legitimately belongs to him, and upon which he must depend to maintain his financial standing in the trade. To steal his business is to drive him into bankruptcy, and the manufacturers and jobbers who do this are depriving him of the means with which to pay his indebtedness to them. In days gone by, many a retail dealer has been ruined by the competition begot of this unbusinesslike practice of jobbing goods to outsiders, combined with the peripatetic auctioneers, who are sent out by greedy manufacturers or jobbers to flood the country with cheap goods. If these practices are being revived, the retail dealers must come together in their united strength to put an end to them. There is trade enough for all if conducted on good business principles, and if there are those whose greed prompts them to take unfair advantages, the entire trade should combine against them. Manufacturers owe a duty to the retail dealer to protect his integrity, and that is to insist that the jobbers to whom they sell shall not sell to outsiders or seek a retail business. The line of demarkation between a jobbing and a retail trade is clearly defined, and he who poaches upon the preserves of the other should be severely punished for his temerity.

Another abuse that retail dealers complain of is the practice indulged in by certain drummers for irresponsible houses who have not yet attained to the dignity of commercial travelers. This is a practice they have of visiting a town, and, after selling all they can to the regular retail dealers, selling their goods to all sorts of outsiders at the same prices, and even paying their hotel bills with goods from their sample cases. By these means the community is flooded with goods at prices with which the legitimate dealers cannot compete. The house these cheap drummers represent should be as absolutely tabooed by the trade as those who send out catalogues and price lists to outsiders. Both practices are unbusinesslike and demoralizing, and no words of ours are equal to describing their disastrous effect upon the retail dealers.

Retail dealers at best have a serious struggle to maintain themselves, and those to whom they have a right to look for protection should not furnish the club to beat out their brains. The regular dealer has a reputation to maintain in his community; the goods he sells must be such as he can conscientiously recommend, and hence he cannot handle many of the goods, made, perhaps, in almost exact imitation of those he has in stock, but having no intrinsic value, that the barber, the grocer and the notions dealer may sell with impunity, because they have no responsibility in connection with them. Hence this outside trade should be discouraged by everyone interested in maintaining the integrity of the retail dealers. In many instances the country dealer must be his own repairer, for he cannot afford to hire a workman. His time is divided between the bench

and the sales counter, and he has no leisure to keep track of the petty devices resorted to to steal away his trade. This constitutes another reason why he is entitled to protection at the hands of those who are quick enough to condemn him if he fails in his obligations to them. The retail dealer who does his own work must needs have the patience of Job to get through his work; in the midst of a delicate job of repairing, he is liable to be interrupted many times by customers who want some trifling things; his brains are in the watch on the bench, while his customer is haggling over the price of a watch key, and telling him he can buy the same thing at the hardware store for less money. No wonder they become irritable and hurl anathemas upon the heads of those drummers who fill the town with goods so that his neighbors can undersell him. Time after time he is called from his bench by trivial things, and what between striving to serve his customers and seeking to do an honest job of repairing, he is driven nearly wild. But through all his trials and tribulations he must maintain his reputation for doing honest work and selling honest goods. Success is difficult for him to grasp under the most favoring circumstances, but when the jobber and the drummer combine against him, it is little wonder if he is driven to bankruptcy.

But in one respect retail dealers increase their own burdens. They are too prone to distrust one another, and to enter into a disastrous competition. They are too credulous of evil reports regarding competitors. If Jones comes to Robinson to look at a watch, and says Brown offered him a similar one for a less price, forthwith he begins to abuse Brown, never thinking for a moment that Brown can be innocent and Jones lying. So he offers the watch below the price named, and forthwith Jones goes to Brown and repeats Robinson's offer, and then Brown gets mad and says unpleasant things about Robinson, and the two become deadly enemies forever after, losing no opportunity to undersell each other. And this state of things is brought about by a meddling busybody while haggling over the price of a cheap watch. Dealers should cultivate each other more, and learn to have confidence in the statements made one to another. It only needs confidence between themselves to prevent such ruinous competition, and to enable them to conduct their business on a basis of a fair margin of profit. Let Robinson and Brown come together socially and they will soon learn to respect each other, and when this is done, there will be no disastrous rivalry between them. There is no reason why a business competition should engender personal hatreds, as is too often the case. Competing dealers, instead of having a pleasant business understanding between themselves, are too apt to assume the aggressive and seek to "run out" a rival by underselling him. Cutting prices is a game two can play at, but is very apt to prove a serious affair to both in the end. A retail dealer should be a man of the strictest integrity, whose "word is as good as his bond;" his work and his sales should be upon honor, and his perseverance and his patience should know no limit. Such a man will succeed in the end anywhere, for he will rigidly command the confidence of his fellow citizens. The retail trade is full of just such men in every section of the country, and they should be encouraged. Honest work will tell every time. Manufacturers and jobbers owe it to themselves to sustain the retail dealers in their efforts to control the business that legitimately belongs to them, and we hope to see an effort made by them to discountenance the abuses to which we have alluded.

Protection for Retail Dealers.

OWING TO the fact that many retail jewelry stores in different parts of the country had been robbed recently by burglars, the Jewelers' Protective Union a short time since issued a cautionary circular to the trade, warning dealers that many professional thieves were traveling through the country seeking opportunities to commit depredations, and advising retail dealers to provide extra safeguards for the protection of their property. This advice was timely, and should be taken by every dealer as personally addressed to himself.

No other class of merchants are so liable to be robbed as jewelers, as their stocks offer a special temptation to thieves. Their goods are easily carried away, and possessed of positive intrinsic value, and can be readily disposed of at good prices by the thieves. Purchasers of stolen goods will pay nearer the face value of jewelry than for any other kind of goods, and are known to be in league with thieves and assisting them in their robberies. From every point of view, the thieves regard a good stock of jewelry as the most profitable kind of property they can raid upon, and it is not surprising, therefore, that the percentage of jewelry stores robbed is greater than among any other class of mercantile establishments. To such an extent have these robberies been carried that something more than cautionary signals is required for the protection of the retailers. It is a well known fact that very few of the stores of country dealers are properly secured from outside invasion. The safes commonly in use are of little value as against professional burglars. Manufacturers of safes have expended their ingenuity more in the direction of making them fire proof than burglar proof, and in providing intricate locks to puzzle owners. But burglars care nothing for locks, and the element of fire does not enter into their consideration. Give two or three enterprising burglars time and opportunity and they will break through the best "patent fire and burglar proof safe" ever made. By simply drilling two or three holes through the outside shell, filling them with powder and exploding it, the contents of such safes are at their mercy. It is almost useless, therefore, for retail dealers to trust entirely to safes for the protection of their property. What is required is additional vigilance of a personal character; more watchmen and more convictions of thieves.

This is a matter that reaches beyond the retail trade, and affects the creditor class quite as nearly as it does the retail dealers. Experience proves that a large proportion of the goods stolen had not been paid for by the dealer, and when they have passed beyond his control and the possibility of recovery, he comes on to New York, calls his creditors together, tells his pitiful tale and so excites their sympathy that a compromise of his indebtedness is readily effected. As a matter of fact it is the crediting class that suffers when the retail dealer is robbed, while it often happens that the robbery is a direct benefit to him, relieving him of a stock of unsaleable goods, which is replaced by a fresh stock purchased on the credit excited by the fact of the robbery. It is, therefore, quite as much in the interest of the creditor class as the retailers that additional precautions against robbery should be provided. Honest retailers will, of course, do all in their power to protect their stock, both on their own account and that of their creditors, but they are not all in a situation to do all that is required. In spite of their precautions, they are liable to be raided by skilled burglars, and here is where organized effort should come to their assistance. Small cities and villages cannot afford an adequate police force to hunt down daring criminals who visit them occasionally, and we suggest that there should be organized action within the trade to assist in pursuing and convicting thieves who rob jewelry stores. Such an organization might be so constituted as to afford to retail dealers throughout the country the same measure of protection that the Jewelers' Protective Union affords to commercial travelers in the trade. When a robbery occurs, the facts might be communicated at once to the officers of the association, who would at once set the proper machinery in motion to run down the thieves and recover the stolen property. It has come to be known among the criminal classes that if they rob a traveling salesman for a jewelry house they will be prosecuted to the bitter end. As a consequence, not a trunk was stolen last year, when it used to be a matter of frequent occurrence. Equally vigorous measures adopted for the protection of retail dealers would secure equal immunity to them. We would suggest that the trade in this city form such an organization, and urge retail dealers throughout the country to become members. Certificates could be issued to members which, in case of their being robbed, would entitle them to the services of efficient detective agencies to hunt down the thieves, the cost of such detective work

to be borne by the association. We do not question but a majority of the retail dealers in the country would gladly contribute to the support of such an organization, and thus secure to themselves a degree of protection from the criminal classes that they cannot otherwise obtain. It would require but a few convictions to teach professional burglars and thieves that jewelers' establishments cannot be robbed with impunity, even though they are located in some obscure country village. Robberies of retail stores have multiplied with so much rapidity of late that some measures for their protection are absolutely necessary. Obviously it is impossible to prevent robberies in localities where the police force is necessarily small and buildings comparatively insecure. The next best thing is to recover, by organized effort, as much of the stolen property as possible, and inflict upon the robbers such summary punishment as will deter them from disturbing the property of jewelers in future. Such an organization as we suggest could also do good service in breaking up the dens of the receivers of stolen goods in the large cities. It is well known that many, if not a majority, of the large burglaries are planned by these "fences," who receive the goods and dispose of them as opportunity presents. They have such intimate business relations with each other that goods stolen in one city are immediately shipped to a distant one and there worked off upon an unsuspecting public. Organized efforts to detect and prosecute these persons would soon make them chary of buying jewelry from thieves. There are other ways in which such an association might make itself of value to the trade and at little cost to any individual, which would readily suggest themselves to its promoters. We hope to see action taken on this suggestion at an early day, for we are confident valuable results can be obtained by its practical adoption.

Tinkering the Tariff.

CONGRESS has adjourned, and the business interests of the country experience great relief in consequence. Ever since the beginning of the session in December business has been unsettled, because it was generally understood that the tariff tinkers were determined to revise the tariff, disturb values, and generally create an upheaval among vested interests. No sooner did Congress assemble than the tinkering began, and for four months little was heard but debates and squabbles over the tariff and revenue bills. Finally, at the last moment, a tariff bill was passed changing the duty on many things and leaving others in a chaotic condition. It will be months before the country understands just what changes have been made, and business adapts itself to them. If it could be fully understood that this would be the end of the meddlesome work of hay-seed congressmen for a series of years, the matter would not be so bad, but there is danger that the squabble may be renewed at any time. Congress ought to give the country assurance that no attempt will be made to revise the tariff oftener than once in five years. The changing conditions of our development and our resources prevent the enactment of a cast iron tariff that shall be unchangeable, but no interest would suffer if a fixed tariff were made that should be held sacred for five years. A remodeling of it at the end of that time would not bring nearly so many hardships nor so discourage business enterprise as this perpetual threat of changes that hangs over us every year.

The changes made in the new bill that affect the jewelry trade are not numerous, nor will their effects be seriously felt. We give below the features of the bill that relate to jewelry and kindred goods:

SEC. 2496. No watches, watch cases, watch movements, or parts of watch movements, or any other articles of foreign manufacture, which shall copy or simulate the name or trade mark of any domestic manufacture, shall be admitted to entry at the custom houses of the United States, unless such domestic manufacturer is the importer of the same. And in order to aid the officers of the customs in enforcing this prohibition, any domestic manufacturer who has adopted trade marks may require his name and residence and a description of his trade marks to be recorded in books which shall be kept for that purpose in the Department of the Treasury, under

such regulations as the Secretary shall prescribe, and may furnish to the department fac similes of such trade marks; and thereupon the Secretary of the Treasury shall cause one or more copies of the same to be transmitted to each collector or other proper officer of the customs.

Antimony, as regulus or metal, ten per centum ad valorem.

Britannia ware, and plated and gilt articles and wares of all kinds, thirty-five per centum ad valorem.

Bronze powder, fifteen per centum ad valorem.

China, porcelain, parian and bisque ware, earthen, stone and crockery, including plaques, ornaments, charms, vases and statuettes, painted, printed, or gilded, or otherwise decorated or ornamented in any manner, sixty per centum ad valorem.

China, porcelain, parian and bisque ware, plain white, and not ornamented or decorated in any manner, fifty-five per centum ad valorem.

Chronometers, box or ship's, and parts thereof, ten per centum ad valorem.

Clocks, and parts of clocks, thirty per centum ad valorem.

Coral, cut, manufactured, or set, twenty-five per centum ad valorem.

Cutlery, not specially enumerated or provided for in this Act, thirty-five per centum ad valorem.

Dutch or bronze metal, in leaf, ten per centum ad valorem.

Epaulets, galloons, laces, knots, stars, tassels and wings, of gold, silver or other metal, twenty-five per centum ad valorem.

Fans of all kinds, except common palm-leaf fans, of whatever material composed, thirty-five per centum ad valorem.

Japanned ware of all kinds, not specially enumerated or provided for in this Act, forty per centum ad valorem.

Jet, manufactures and imitations of, twenty-five per centum ad valorem.

Jewelry of all kinds, twenty-five per centum ad valorem.

Papier-maché, manufactures, articles, and wares of, thirty per centum ad valorem.

Precious stones of all kinds, ten per centum ad valorem.

Quicksilver, ten per centum ad valorem.

Watches, watch cases, watch movements, parts of watches, and watch materials, not specially enumerated or provided for in this Act, twenty-five per centum ad valorem.

The following are placed in the free list:

Brazil pebbles for spectacles, and pebbles for spectacles, rough.

Bullion, gold and silver.

Catgut strings, or gut-cord, for musical instruments.

Coins, gold, silver, and copper.

Diamond dust or bort.

Diamonds, rough or uncut, including glaziers' diamonds.

Glass plate, or discs, unwrought, for use in the manufacture of optical instruments.

Lava, unmanufactured.

Models of inventions and other improvements in the arts; but no article or articles shall be deemed a model for improvements which can be fitted for use.

Pearl, mother of.

Philosophical and scientific apparatus, instruments and preparations, statuary, casts of marble, bronze, alabaster or plaster of Paris, paintings, drawings and etchings, specially imported in good faith for the use of any society or institution incorporated or established for religious, philosophical, educational, scientific, or literary purposes, or encouragement of the fine arts, and not intended for sale.

Platinum, unmanufactured, and vases, retorts and other apparatus, vessels and parts thereof, for chemical uses.

Plumbago.

Works of art, painting, statuary, fountains, and other works of art, the production of American artists. But the fact of such production must be verified by the certificate of a consul or a minister of the United States indorsed upon the written declaration of the artist; paintings, statuary, fountains, and other works of art, imported expressly for presentation to national institutions, or to any State, or to any municipal corporation or religious corporation or society.

THE FIFTH annual meeting of the Jewelers' Protective Union was held at the rooms of the Jewelers' League on the afternoon of March 5. The reports presented by the officers of the work done by the Union since its organization were most satisfactory, showing that the trunks of travelers in the trade are now subject to less depredation than ever before, as not a trunk was stolen last year. Through the persistent efforts of the Union, twelve or four-

teen well known thieves, who made a business of robbing jewelers' trunks, have been brought to punishment. The motto of the organization is punishment, but no compromise with thieves. This is recognized by the criminal classes, and they have made up their minds that it is dangerous to fool with the property of travelers for jewelry houses. Under an arrangement with Pinkerton, all his detective agencies are placed at the disposal of the Union, and whenever a robbery has occurred the detectives have shown extraordinary vigilance in bringing the criminals to justice. The Union has issued 378 certificates to contributors, each of which entitles the holder to command the services of the detectives in case a robbery is perpetrated. A large fund has been accumulated for the prosecution of criminals, and no effort will be spared in the future to bring to justice any who may have the temerity to make free with the trunk of a traveling man in the jewelry trade. At the recent meeting all the old officers of the Union were re-elected, as follows: President, William R. Alling; Secretary and Treasurer, Ira Goddard, No. 14 John street, New York; Executive Committee, L. A. Parsons, Enos Richardson, S. Oppenheimer, William Smith, and I. M. Miller.

WE HAVE, on several occasions, pointed out the importance of establishing in this city a Jewelers' Exchange, where manufacturers, jobbers and buyers could meet and transact business, and, at the same time, familiarize themselves with what is going on in the trade. Our suggestion has not been acted on in this city, but in Chicago private parties have undertaken to do something of the sort. Having purchased a large building in a central location, a portion of it is to be fitted up for headquarters and samples for the traveling representatives of the jewelry trade. A capacious vault is provided to secure safety for their goods, desk room and office conveniences are furnished, while telephonic communication with all parts of the city is provided. The building is equipped with elevators, gas, etc., is evenly heated, and, in short, every convenience will be offered to make it an attractive headquarters for the trade. It appears to be the plan to rent desk room permanently, so that non-resident firms can keep a representative there at all times. The scheme offers many advantages to travelers, but it falls far short of being a Jewelers' Exchange, such as we propose for New York, to be controlled by the trade instead of private parties. This move is a step in the direction of bringing about closer relations between members of the trade, and we hope to see it ultimately developed into a legitimate Jewelers' Exchange.

United States Coins.

THE NEW YORK *Times* discourses with much truth and ready wit upon the devices with which our coins are embellished:

The effete monarchies have one advantage over us—they can put the effigies of their sovereigns on their coins. It would be preposterous for us to imitate this example by issuing an entirely new set of coins every four years bearing the likeness of a new President, and, were any President to attempt to immortalize his features in connection with the coinage, he would be fairly driven out of the country by the ridicule which would be lavished upon him. In default of anything else to place upon our coins we have attempted to embellish them with Goddesses of Liberty, Indian warriors, flying eagles, and other objects, and have succeeded in producing the worst set of coins in use by any civilized nation.

The Goddess of Liberty who appears on the half-dollars, quarter-dollars, and dimes, seated gracefully upon nothing, and holding with one hand a night-cap on a stick and with the other a shield, probably had a few features when she was young, but at the present time she has none. There is a slight irregularity in her profile suggestive of a nose, but this is the only hint that she ever possessed either nose, eyes or mouth which she affords us. Still, this peculiarity might be overlooked were it not for the fact that she possesses two right

legs and no left leg whatever. Whether this is meant to show that American liberty is a monstrosity, or whether it is intended to account for the perpetual sitting position maintained by the Goddess, there are no means of judging. There can, however, be no doubt that as a work of art the Goddess of Liberty is a failure. A goddess with defective legs is unworthy the worship of any person of æsthetic tastes, and when the defect consists of a total absence of left leg and a preposterous quantity of right legs, it admits neither of defense nor palliation.

The single heads that appear on certain other coins are no better than the full length goddess. The best of them is the Indian of the copper cent. His expression has perhaps a little too much of the delicate refinement of the fashion plate, but his back hair is certainly very powerful and impressive. Exception might be taken to the English legend which appears on his forehead—or rather temple—but as he is a heraldic and not a realistic Indian, the language of this legend is of little consequence.

Certain other heads have been alleged by the authorities of the Mint to be nothing less than portraits of beautiful young ladies of Philadelphia. If this be true, the question arises, why should Philadelphia alone have the honor of providing effigies for the coins of the whole country? Has not Boston a right to have at least one coin decorated with the head of a Boston Goddess of Liberty, wearing spectacles and gazing intently upon a copy of Emerson's essays? Cannot Chicago claim to have the full-length portrait of one of her fair daughters placed on, say, the fifty-cent piece, one of her shoes being exposed so that the sole could afford a place for the various inscriptions that are now placed on either side of the coin? Is there any reason why Cincinnati should not demand her share of coinage honors, and insist that a full-grown and majestic pig should take the place of the Goddess of Liberty on at least one of our coins? As for New York, she, of course, would claim nothing—partly from modesty and partly from unwillingness that a New York girl should be libeled by the engraver who makes the dies for the Philadelphia Mint.

This custom of placing the head of a Philadelphia girl on the national coins is not only unfair to other cities, but it is grossly unfair to the Philadelphia girls. People who have seen the new five-cent coin with the alleged portrait of one of the most beautiful girls of Philadelphia mentally resolved never to visit that city, and are for the rest of their lives firmly convinced that Philadelphia girls are as plain as Philadelphia streets. This, as every man of experience knows, is a grave mistake. The girls of Philadelphia are so irresistible that even Benjamin Franklin fell in love with one before breakfast, and before he had been in the city twenty minutes. In all probability the Philadelphia beauty who sat for the five-cent piece is really beautiful. In that case she must certainly be an orphan, without a brother, a lover, or even a male cousin—for in no other way can the fact be explained that the engraver who libeled her still lives.

The old five-cent piece, with its partially flattened crab on one side and the majestic figure "5" on the other, was bad enough, but the new coin is nearly as bad as the half-dollar and its goddess with the surprising legs. The only argument which can be urged in its favor is that when carefully gilded it can be palmed off upon a newly arrived European as a five-dollar gold piece. In the eyes of those statesmen and financiers who think it a fine thing to pay out silver coins worth eighty-four cents on the pretext that they are worth a dollar, this is a powerful argument, but most people are convinced that the silver dollar is a sufficient disgrace to the nation, and that we need not go further in the work of placing spurious coins in circulation.

The German Imperial Insignia.

IF THE struggle for the possession of gold and rare works of art has in general entailed untold woe and misery on mankind, a fact so strikingly illustrated by nearly all the large diamonds of the world, the history of which reeks with murder and rapine, there is

perhaps no lump of gold, no number of pearls, no diamond or jewel, that can boast of a mightier and more eventful history than the German Imperial Crown, or scepter and apple of the "Holy Roman Empire."

For the last 3,000 years the mighty of this earth loved to array themselves with crowns and other insignia, to express therewith the dignity of rule, and we find the first definite mention of a crown in II Samuel, xii, 30, as well as in the same book of Samuel, i, 10.

It may be asserted with full confidence that the Greeks, at least during the heroic age, possessed no crown; the ornament nearest approaching it was the so-called Apollonic rays, consisting of a narrow head hoop and upright prongs. The Romans, on the other hand, conferred five or six different kinds of crowns for civic or martial merits. After this short digression, let us return to our subject.

The date of these insignia, as well as the commencement of the art of goldsmithing, is lost in the dimness of antiquity, but it is generally presumed that they date from the time of Charlemagne (768 to 814, A. D.); the style of workmanship shows that both crown and sword were made prior to other pieces.

The crown consists of gold, and is ornamented with many jewels and pearls. It weighs $7\frac{1}{4}$ pounds, together with the velvet skull cap within, the gold is twenty-one karats fine, while the enameled pieces thereon are twenty-four. The work betrays great care, and the crude, that is, uncut, jewels, are raised upon thin tubes, set *à jour* and retained by claws. The perforated pearls are fastened with gold wire. The crown consists of eight upright standing plates, semi-circular above, and fastened within to two narrow iron hoops. These eight fields or plates are very prominent; their height and breadth is unequal, the front plate 126 millimeters high and 103 mm. broad; the back plate is of the same height, two other fields with jewels are 108 mm. high and 75 mm. broad; while the other four fields, with figures, are 103 mm. high and 77 mm. broad. A second gold arch about 40 mm. broad and 30 mm. thick passes from the front to the back plate; it is hollow within, of course, passing above the head, and upon which, immediately above the front plate, stands a small cross 20 mm. high. Four of the eight fields are set with jewels and pearls, alternately, while those occurring between are of fine enameled work, and represent allegories with gold inscriptions. Many of the jewels have been perforated, and have undoubtedly been used for some other royal ornament; they are entirely crude, neither cut nor polished, and in the condition as when found. They have been set very carefully. It is unnecessary to enter into a description of the jewels, and we will confine ourselves to the enameled allegories.

The second plate of the left contains the picture of Solomon, surrounded with ten sapphires and fourteen pearls. He stands erect and holds a dark blue scroll in both hands, bearing the Latin inscription, "Fear God and love the King." Above him, in red block-letter text, stands "Rex Solomon."

The fourth plate represents the picture of King David, which also is encircled by ten sapphires and pearls; the lowest sapphire is a false one. King David holds a blue enameled fluttering scroll, containing the Latin verse in gold letters: "The honor of a King consists in his judgment." Above his head, "Rex David."

Upon the sixth field we see the figure of the sick King Hezekiah; his head is supported upon his arm, and the prophet Isaiah stands at his side; a blue scroll in his hand, with the Latin inscription, "Ecce, a dicam super dies tuos XV. annos." (Behold, I will add to thy days fifteen years). Their names stand above.

The eighth plate portrays Christ in a red dress, with a cherub on each side. A band of ten sapphires and pearls encircles his head, and at his feet are the words, "Through me reign the Kings." Since the gold of the four enameled plates is finer by three karats, it may be accepted that these plates already belonged to a former crown, and were used subsequently for this one.

Christ is represented with a black beard, his head surrounded with a green halo, with blue borders, in which floats a red cross. He sits

barefoot upon the throne, upon which lies a blue, red and green lustered cushion. His cloak is dark blue, with a yellow border; his undergarments are blue, with red sleeves. Both are ornamented with jewels. He holds the thumb and forefinger of the right hand aloft, and with the left he holds a square, light blue in the middle, red at the ends, upon his lap. Apparently this is to represent the Holy Evangelists.

The two cherubim, standing near the Saviour, have four wings, blue, red, white and green, and are also barefooted. The figures are not very skilfully worked, and it is believed with reason that they were executed by Byzantine workmen in the sixth to eighth century.

The cross upon the crown is an independent piece, and weighs about one quarter of a pound. The front is covered with large emeralds, rubies, garnets, pearls, etc. The reverse is a crucifix. Enameled drops of blood issue from hands and feet. The Saviour's head is surrounded by a saint's halo, in which a cross floats above his head. The face is beardless, but surrounded by the long hair of the head, and the eyes are open. It is evident that the cross is of a more recent date than the plates of the crown. The arch spanning the head consists of eight semi-circular separations, bearing the following Latin inscription formed of pearls, "Conrad, by the grace of God, Roman Emperor," (1138).

The crown, in its many narrow escapes from destruction, and very eventful existence, has repeatedly been damaged, and bears the visible marks of rough usage; indeed, it would be difficult to trace up its many possessors and fortunes. Especially in the year 1106, during the reign of Henry V., it fell into the hands of a rebellious district; another time in 1209, during the conquest of the Italian town Vittoria, the Parmesan soldiers conquered it, and declared it to be lawful booty. Several pieces were lost at this time.

It was finally delivered to Vienna in 1818, where it rests at present after its struggle of a thousand years, having changed possessors of Goths, Visigoths, Huns, Vandals, Italians, French, Germans, etc., and cost not alone rivers, but oceans of blood to insure its momentary possession. It can be seen to-day in the Austro-Imperial treasury in box XXIX, from numbers 1 to 29.

After the German Emperor William was crowned in 1871 at Versailles, during the thunder of cannon before the besieged city of Paris, the Emperor of Austria offered him said crown, sword and other insignia of state once belonging to Charlemagne, but the former refused them. It is beyond our knowledge whether the old gentleman, together with these insignia, equally refused to burthen himself with the many traditions of the "Holy Roman Empire."

THE MANUFACTURE of toy watches has assumed most colossal proportions in Paris; according to the *Petit Journal* one factory alone manufactures 3,000 such watches per hour. The aforesaid journal says that in the year 1863, there were only three modest manufacturers of toy watches in Paris, occupying about 50 persons, while at present there are seven large establishments, occupying directly more than a thousand workmen, while indirectly the number would grow beyond it fourfold, many workmen being independently engaged in the manufacture of watches "that can be wound up, and the hands of which can be set." All this expansion is due to the energy of one diligent and skilful workman, Mr. M. Hony, who, by the application of mechanical contrivances which he introduced in 1865, stands to-day at the head of a large establishment. The visitor is astonished at seeing the life and thrift of a factory in which, in the course of a year, without interruption, except Sundays, 30,000 watches per day, or 3,000 per hour, are finished ready for sale. This number expresses about one-third of the entire Paris manufacture, and it is possible to attain such a result only by the division of labor. The most simple watch, which at wholesale is sold at two centimes, passes through more than twenty hands. On a whole, Paris manufactures more than 100,000 toy watches per day, of which France consumes about one-tenth part, by which an export of more than 1,000,000 francs is understood.

MR. E. C. FITCH, of the firm of Robbins & Appleton, was recently appointed Assistant Treasurer of the American Watch Company, of Waltham. As is well known, Mr. Royal E. Robbins has been the Treasurer and Manager of the Company since its organization, and especially charged with the direction of the factory. Under his skilful management the factory has been developed—having been twice rebuilt—from small beginnings, until to-day it is the most complete factory of its kind in the world. It is here that has been perfected that wonderful system by which American watches are made by machinery. To do this, it has been necessary to invent, construct and perfect machinery for the manufacture of the different parts constituting a watch movement, and the immense factory at Waltham is filled with the most ingenious and delicate machines that can be devised, some of which are so nearly human in their work that they can, apparently, do everything man can do but talk. To bring this factory to its present condition, Mr. Robbins has devoted between twenty-five and thirty years of his life, and must now view with peculiar satisfaction the results of his labors. After these many years of overwork, Mr. Robbins felt that his cares and responsibilities should be lessened somewhat, so, at his suggestion, the position of Assistant Treasurer was created, and Mr. Fitch appointed to fill it. Mr. Fitch has been identified with the business from childhood, and is eminently fitted to assist Mr. Robbins in the management of this vast industry, that gives employment to upwards of 2,300 persons. He has an excellent mechanical mind, and is possessed of executive ability in a remarkable degree. He is familiar with every department of the business, and will assume the active management of the factory under the advisement of Mr. Robbins. The Treasurer and his new Assistant understand each other thoroughly, are in perfect harmony in their ideas, and under their joint management a new impetus will be given to the business of the American Watch Company. We congratulate Mr. Robbins on having secured so valuable a co-worker, and Mr. Fitch upon the opportunity thus given to develop ideas and faculties that have lain dormant within him heretofore.

Newport's Old Clocks.

CURIOUS ACCOUNT OF A FASHIONABLE MANIA—THE DUTCH CLOCK CRAZE.

IN NO TOWN or city in New England, with the exception of Salem, Mass., can so many English hall clocks be found as in Newport. They may be found in this city in the possession of the descendants of many of the old families, and the majority were made here by manufacturers by the name of Williams & Cleggett. These manufacturers sent many clocks to various parts of the country, and they finally moved from Newport. A prominent cabinet-maker, Mr. George E. Vernon, some time ago purchased fifty English hall clocks, which were found in Virginia, they being once the property of the aristocratic families of that state. During the war, when vandalism was rampant and when the Union army took possession of the state, these clocks were stolen by the negroes and taken to their log cabins. In order to make use of them it was found necessary to saw the tops and bases off, as it was impossible to place them in an erect position without taking this course. They were in a dilapidated condition, and were purchased for a mere song. When they arrived here they were put in the hands of first-class cabinet-makers, and were soon in a condition which induced buyers to pay large sums for them. They were almost exclusively purchased by the summer residents, who placed them in their cottages. One lady, who belongs in Providence, purchased five, which she gave away as wedding presents. The works of the Virginia clocks were all made in England, and were set up and furnished with cases in this country. Nearly all of the clocks had the moon attachments. The finest one in the lot was purchased by Mr. George Peabody Wetmore, of New York. It was found in Petersburg, Va., and was made in Edinburgh, Scotland. It is handsomely carved, the top being surmounted with three gilt

figures, two being female heralds, and the third, which is in the center, is Atlas holding up the earth. It has the moon attachments and the days of the month. The names of the makers of the Virginia clocks were Frederick Heisler and John Fessler, who died about one hundred and twenty-five years ago. Mrs. Henry Vernon has one in her possession which was made in 1810 by Job Stanton, of this city. It is estimated that there are at least one hundred of this particular kind of clock in Newport, and they range in value all the way from \$100 to \$300. The cases are made of cherry, mahogany and English walnut. There now promises to be a mania for Dutch clocks, which are more attractive in every way and are more expensive than the English clocks. Mrs. W. R. Travers, Mr. Theodore A. Havemeyer, and Mr. Ogden Goelet, all of New York, have purchased Dutch clocks for their summer houses at this place. Mrs. Travers' cost \$900 and that of Mr. Goelet \$620. The Dutch clock, therefore, promises to be extensively used at Newport by her aristocratic visitors. During the revolutionary war the works of an English clock were buried at Narragansett, while the case remained here. After forty years the works and case came together and are now owned by a Providence gentleman, a descendant of the original owners. The works, notwithstanding the fact that they were buried many years, are in excellent order.—[*N. Y. Evening Telegram*.]

IT IS a common practice to descry the present as an age of shams, especially in relation to many manufactured articles. But the experience of a lady of title who wished the other day to dispose of some handsome jewelry, presented to distinguished ancestors, male and female, by very illustrious personages, shows (says a European Court journal), that the art of shamming was carried to a very high degree in the days of our grandfathers and grandmothers. The lady in question, desiring to dispose of these precious and honored objects, consulted a well-known jeweler. Producing from a velvet and emblazoned case a superb set of rubies, she inquired what sum could be obtained for them, remarking at the same time upon their magnificent appearance, both as to the color of the stones and the setting. The jeweler examined them carefully and said: "They are certainly very showy, madame, but unfortunately they are not genuine stones. They are, in fact, clever imitations in glass. The lady, much chagrined, then called attention to the heavy settings, to which the jeweler replied, after the usual tests, "The setting, madame, is only gilt." Another article produced for appraisalment was a superb bracelet, the gift of a sovereign to the wife of a distinguished diplomatist. The skilful manufacture and specific gravity of this splendid object had been extolled for generations in the family of the possessor, and so highly prized that it was invariably sent to the banker's when the family went out of town. The jeweler scrutinized it very carefully, and pronounced it to be extremely heavy; "but," he added, "if you will allow me to raise this very thin plate, I shall be able to show you that the bracelet is filled up with lead." The lady of title was so much shocked that she declined to submit any more articles to this candid and able judge.

Obituary.

HON. T. A. RICHARDSON.

The death is announced of Hon. T. A. Richardson, the well-known jeweler of Winona, Minnesota. Mr. Richardson was but twenty-seven years of age, yet by his energy and ability had become a leading citizen in the city of his residence. Last fall he was elected to the legislature by the largest majority ever given to a candidate of his party in his district. The father of Mr. Richardson was a jeweler, but died when the son was but fourteen years old. The young man then determined to continue his father's business, and has done so with marked success. The Winona city papers speak of the death of Mr. Richardson as a calamity to that community. He was an energetic and enterprising business man, and one possessed of sterling integrity. His death will be deeply regretted by all who knew or had business transactions with him.

Proceedings of the Horological Club.

A DISTINGUISHED BODY OF WATCH AND CLOCK MAKERS.

One hundred and sixth Discussion.—Communicated by the Secretary.

(NOTICE.—Correspondents should write all letters intended for the Club separate from any other business matters, and headed "Secretary of the Horological Club." Direct the envelope to D. H. Hopkinson, Esq. Write only on one side of the paper, state the points briefly, mail as early as possible, as it must be received here *not later* than the eighth day of the month, in order to be discussed and reported in the CIRCULAR for the next month.

USING BOTTUM'S HAIR-SPRING GAUGE.

Secretary of Horological Club:

Please inform me how to use Bottum's hair-spring gauge. I have asked several, but as yet cannot get the information. T. W.

Mr. McFuzee replied that the hair spring is fastened in the gauge at the proper points, both at the center and at the outside, in the slots of the gauge. The catch which projects at the side is then moved to the other end of the slot, and the strength of the spring is found on the dial. If the old spring is on hand, and is not broken or bent out of shape, it can be tested in the gauge to find its strength, after which it only remains to select another similar spring having the same strength, and put in its place. If the old spring is gone or ruined, the workman selects one as nearly right as possible, and tries it with the balance in any well-known way. If it is found unsuitable in strength, it is then measured in the gauge to determine what its strength is, and another is selected whose strength is greater or less by as many degrees as the workman's judgment may indicate as likely to be suitable. The gauge does not tell the proper strength of spring required for the particular balance, any more than a pinion gauge will tell the proper pinion for a particular wheel. The gauge is simply a measuring tool to measure comparative strength of springs, as other tools measure lengths or thicknesses of wires or other parts. Of course pains must be taken to hold the spring in the gauge as nearly as convenient at the same places as it will be pinned in the watch.

Many workmen do not use the gauge at all in selecting springs. They pick out one whose coils have the proper width and openness or distance apart, spring the center coil over the balance collet, clasp with the tweezers the coil which would naturally fall between the pins of the regulator if pinned in the watch, then raising the tweezers till the balance pivot only rests lightly on some hard surface, as the top of a watch crystal, the balance is caused to vibrate, and the vibrations are counted for one minute, or a half-minute. The spring is of course so held as to keep the balance level while vibrating. The number of vibrations per minute is known for the common kinds of watches, or is easily found in any special case by counting the teeth and leaves of the train, calculating for the escapement, etc. If the vibrations of the spring on trial are but a few more or less than desired, it can be corrected by clasp the spring a little to one side or the other, to lengthen or shorten it. But if there is a difference of quite a number of vibrations, it is better to select another spring. Rules for calculating the proper number of vibrations, selecting springs, fitting them in the movement, and making any desired adjustments, even the finest, will be found in Excelsior's "Practical Hints on Watch Repairing," which gives the most complete and reliable instructions on all points of any work he was acquainted with. There are also many special tools and devices made for facilitating the selection and fitting of hair springs, some of them very useful. We are always ready to examine and commend such, whenever their inventors or makers bring them to our notice, and hope those who have gotten up good tools or methods of working of any kind, will not hesitate to lay them before us for discussion at our meetings.

TO ENLARGE THE SCAPE WHEEL OF AN ENGLISH WATCH.

Secretary of Horological Club:

On general principles it don't do to "monkey" with a scape wheel, especially an English scape wheel. The whole thing is fearfully

and wonderfully made, and should always be worked on by the man who made it; but he is generally dead—or should be, to prevent his making any more—and it is some consolation to know that he is (with the man who made the accordeon) paying dearly for each source of profanity he has left as an inheritance to us. Sometimes there are one or two teeth that are too short and will not lock. To spring the teeth out a little will not answer, though some do this. There is no certainty in it, as it spoils the correct action of the escapement.

Take an old pair of flat-nosed pliers, draw the temper at the points, and file them back till they are rather short. Fasten them in the vise and with a hammer beat the points till a small burr is formed on the inside of the points. Now file down the back till either of the points will enter easily between the scape wheel tooth and the rim of the wheel. The finer the point, without making it too thin, the better. Place a fine equalizing file between the points and hold them together on the file, and run the file back and forth till the burr at the points meets evenly all the way across. Now carefully round up the outside of the burr, and the inside a little. This burr wants to be just enough to prevent the jaws of the pliers touching from the points back—no more. To use them, place one point between the tooth and the rim of the wheel, and with a series of short, light pressures, work the pliers toward the point of the tooth, getting lighter as you near the point. This will not only draw the tooth out, but it will harden it a little. If the tooth should show a disposition to twist a little out of plane at the point, turn the pliers over. This will throw it back, and always leave enough metal at the point to dress it down to the width of the other teeth. Take your tweezers and set the tooth the same pitch as the others. It will not jut out much. Then, with your depthing tool, get it the right length. By this means it is possible to do a very good job and save the trouble of putting in a new scape wheel. The only trouble is not to press too hard and get the tooth too thin at any one place, especially at the point, or by a little carelessness bite the tooth off altogether, in which case the best thing you can do is to pass the chronometer (accent the *me*) through an ore crusher, and sue the owner for damages. W. G. S.

Mr. Ruby Pin thought a better way would be to pass the watch through the ore crusher at the start, and use the pliers on the owner of it. That would be sure to bring him to a realizing sense of the enormity of his offense in carrying such a watch, and he would doubtless pass a set of resolutions thanking the watchmaker for relieving him from the burden of his sin. Seriously, however, the method proposed might be successful in proper cases, if followed out with care and judgment. It would be easy to insert a set screw through one point, to rest against the other, and render it impossible for the jaws to come any closer together than was intended. If inconvenient to put it there, the handles could easily be arranged in some similar way, to regulate their distance apart when closed. But a wheel treated in this manner should be very carefully tested, to find whether the teeth are an equal distance apart, and equally inclined, as well as of equal length. This will be most conveniently done in the depthing tool. But he feared that by the time the wheel was gotten into good condition by this method, nearly, if not quite as much time would have been consumed as would have been required to insert a new wheel—and the price of the latter job would be more. Of course, if the workman has not a good stock of wheels to select from, or the owner will not pay for a new one, this kind of repairing is in a measure compulsory—and, as before remarked, with care and skill very good results may be attained.

THE FRITZ COMPENSATION BALANCE.

Secretary of Horological Club:

In Excelsior's "Practical Treatise on the Balance Spring," mention is made on page 119, of a balance invented by Fritz, having "adjustable, radial, compensating segments, based upon the correct principles—very promising," etc.

Will you do me the kindness to tell what periodical I can get containing a *description* of this invention, or can you tell if it has been patented in the U. S.? Nobody knows anything about it around here. Why is it not used? Is it a mechanical failure? What were the essential points of his invention, and, if they were correct, does their failure indicate that the scientific and mercantile world don't *care* for any such progressive step as he undertook? Any information on this subject will be very thankfully received by J. R. S.

Mr. Horologer said that the Fritz balance would admit of very close correction of all the errors of compensation balances, but it would require a skilled workman to adjust it—and in that respect it was unfitted for the general use which the usual expansion balances permitted, as the latter could be altered, or at least tinkered at, by ordinary watchmakers. His balance was also more expensive to construct than those commonly used, although he thought that after one had been fully adjusted it could be used as a guide for making others of the same size, weight, etc., and thus greatly reduce the cost if made in numbers. The principal difficulty seemed to be that the balances already used were good enough for the quality of the movement to which they were fitted. That is to say, after we reduce the compensation errors to a certain point, it is not generally desirable to go any further in that direction, because there are so many other disturbing influences that some of *them* would prevent our getting perfect time even if we could make the *balance* absolutely *perfect*. It was, however, a little surprising that some chronometer maker who wished to "beat the world" on time, did not make an extra superior movement, and fit it with one of these balances, in order to see how near to perfection in time keeping it was possible to come by skill and careful management. The expense of making these balances need not be excessive, especially with the modifications in construction suggested by Mr. Fritz in his memoir describing them.

An illustrated description appeared in *THE JEWELERS' CIRCULAR* some time during the winter of 1874-5, also in the *Watchmaker and Jeweler* during the spring and summer of 1875. He thought that the description also appeared about the same time in the *English Mechanic and World of Science*. The balance was not patented, and Mr. Fritz had generously presented his invention to the trade for the free use of all interested in attaining the acme of perfect time-keeping. It would be impossible to describe the construction without illustrations, and he must therefore refer Mr. S. to the original papers for further information.

BACK NUMBERS OF THE "PRACTICAL HINTS ON WATCH REPAIRING."
Secretary of Horological Club:

I have many times noticed your advertising for *THE CIRCULAR* containing Excelsior's "Practical Hints on Watch Repairing." I have in my possession the whole work, which commences with February, 1876, No. 1, Vol. VII, concluding in August, 1877, No. 7, Vol. VIII, with the exception of one number, viz., July, 1876; No. 6, Vol. VII.

If I was certain that at some future time the work could be procured in book form, I might be persuaded to part with the *CIRCULARS*, if they would be of any valuable aid to anyone in the trade. Otherwise I do not care to part with them, as I understand how to appreciate them, and how valuable the work is to a practical watchmaker.

CHAS. MELCHOR, Watchmaker, Canton, Ill.

Mr. Isochronal said that our correspondent was evidently mistaken about the date at which these articles commenced. The Club's file of *THE CIRCULAR* began with Vol. VII., No. 1, and he was unable to give the date of the first article. But the article in Vol. VII., No. 1, is *number eleven* of the "Practical Hints," series, so that they must have commenced about a year previously. The first series, comprising Nos. 1 to 15 inclusive, have been republished in book form, and are for sale at the office of *THE CIRCULAR*. The mistake is therefore of less importance, as the beginning can be obtained in book form, but the remaining articles can only be found in the back numbers of *THE CIRCULAR*.

A greater error, however, is that the articles were concluded in August, 1877—for they were not ended till nearly *three years afterwards*, or in 1880. Consequently Mr. M. has only a portion of the second series. But many will be glad to purchase even them, and we give his letter and address to assist them. We are constantly receiving inquiries as to when the second series will be republished in book form, why Excelsior does not write more, etc., etc. We can only say that their publication is delayed until he can find time to revise them, which he has not yet been able to do. For the same reason he is unable to write new articles. There is no horological writer so well known to all American watchmakers as Excelsior, or

so highly and universally esteemed by them. Anything from his pen would be gladly received by everyone, and accepted as authority on the subject of which it treated. But, of course, we must wait until he finds opportunity to do either one or the other. And meanwhile we can only advise all who can obtain back numbers of *THE CIRCULAR* containing the articles already written, to do so—and repeat our request that anyone having those numbers, and willing to part with them, will inform the Secretary, with price, etc.

W. F. A. WOODCOCK, PRACTICAL WATCHMAKER TO THE TRADE,
ELECTED CORRESPONDING MEMBER OF THE CLUB.

Mr. Clerkenwell said he wished to make known to the Club Mr. F. A. Woodcock, of Cumberland, Maryland, who has a very complete establishment for doing all kinds of work for the trade. He knew Mr. W. to be an excellent workman, with the very best facilities, and first-class skilled labor, and thought him deserving of a kindly mention in our Proceedings. He gave numerous instances of excellent work done on fine watches for the trade by Mr. W., and proposed him for election as a corresponding member of this honorable body, in order that he might have an opportunity to join with us in affording information to the trade on all points desired, and give them and us the benefit of his experience and skill, by descriptions of new and improved tools and ways of working, answers to difficult questions, suggestions for facilitating the execution of repairs, etc. After further commendatory remarks by other members, Mr. W. was unanimously elected a corresponding member of the Horological Club, and invited to favor us with technical communications as often as he can find it convenient.

Gold and Silver—their Elaboration.

(Continued from Page 50.)

THE SILVER-PLATING fluid may be prepared in two different ways, either by chemically preparing a solution of cyanide of silver in cyanide of potassium, or by the electro-chemical way. The first method answers well for shops of limited working capacity, while the second is more commodious for factories that have silver-plating baths in constant use.

MANNER OF PREPARING THE SILVER-PLATING FLUID BY THE CHEMICAL METHOD.

It was stated already that the silver-plating fluid consists of a solution of cyanide of silver in cyanide of potassium, and such a solution contains the double salt of cyanide of silver and cyanide of potash. This solution may be prepared in different ways, either by directly dissolving cyanide of silver in a cyanide of potassium solution, or else by dissolving metallic silver in cyanide of potassium, and finally by treating nitrate of silver with a cyanide of potassium solution.

As was also stated heretofore, a bath suitable for purposes of silver-plating is obtained by dissolving eight parts of nitrate of silver in distilled water, when one part cyanide of potassium is added to the solution and boiled until the fluid ceases to evolve ammonia.

The direct method is generally pursued by using pure silver and giving the fluid a definite concentration. It is best to proceed as follows: A weighed quantity of dry, chemically pure silver, prepared in the manner heretofore described, is placed into a glass retort with a thin bottom, which, for sake of care, is placed into a porcelain dish; five or six parts of distilled water are poured over it, and nitric acid is added in small portions. The finely divided silver dissolves with the greatest facility in the nitric acid, but care is to be paid not to use an excess of the latter, but to leave a small quantity of the silver remain undissolved on the bottom of the retort.

Water is next poured into the porcelain dish, and the whole arrangement heated gradually until the water boils, and after ebullition has been sustained for one hour, the whole is left to stand in a moderately warm place. A perfectly neutral (that is, free of an excess of acid) solution of nitrate of silver is formed hereby.

After the silver solution has been filtered to clearness into a glass

vessel, small portions of cyanide of potassium solution are added, diligently stirring with a glass rod, but only sufficient until the momentarily produced precipitate of cyanide of silver has redissolved. Sufficient distilled water is now added to this silvering bath that one part by weight of silver is dissolved in 160 parts by weight of fluid.

According to another process, the solution may also be prepared by dissolving ordinary copper-containing silver in nitric acid, separating the silver in form of silver chloride by adding muriatic acid and washing it with distilled water until all the copper has been eliminated and the pure silver chloride in a wet condition dissolves in cyanide of potassium.

PREPARING THE SILVERING FLUID IN AN ELECTRO-CHEMICAL WAY.

The preparation of the silvering fluid by this method is based upon the fact that metallic silver dissolves in a solution of cyanide of potash, by the simultaneous action of the galvanic current, so that a solution of cyanide of silver and cyanide of potassium is obtained.

In order to prepare the silvering fluid by this process, followed in all larger factories, it is necessary to have a sheet of chemically pure silver. Such sheets are manufactured by melting pulverized silver with a little borax and saltpeter in a graphite crucible, casting it in flat pieces and rolling it into a thin sheet. This is bent into a cylinder of corresponding size, its weight is determined exactly, and placed into a glass vessel, capable of holding thirteen to fourteen liters water.

A vessel of porous clay, such as is used in galvanic elements, is placed into the center of this glass vessel, a copper cylinder is introduced into this cell, which is then connected with the zinc pole of a galvanic battery, while the silver sheet is brought into union with the copper pole of the latter. In the thus prepared vessel as well as the clay cell, a solution is found which contains 75 grams cyanide of potassium to 10 liters water.

If a battery of about six elements of modern dimensions is used, a solution suitable for silvering will be obtained in a few hours. The silver sheet, when removed from the bath, is weighed with exactness, and its loss of weight indicates the true quality of the silver that has been dissolved in the fluid, so that apart from the handiness in manipulation, the operator is enabled by this process to tell exactly how much silver is contained in the bath.

THE DESILVERING OF THE SILVERING BATH.

After the bath has served for some time, and contains only a small quantity of silver in solution, it can no longer be employed. In order to recover the silver still contained in it, muriatic acid may be used, by which the solutions are decomposed. It produces potassium chloride and silver chloride; the latter falls down in an insoluble condition, and prussic acid is evolved in a gaseous state from the fluid.

We have, in a previous place, spoken of the extremely poisonous nature of prussic acid, and cannot recommend the desilvering of exhausted baths by this method; the less so since by the employment of the galvanic current we can effect the desilvering of the bath in a perfectly harmless manner. If, however, the desilvering of an old bath is to be effected nevertheless by treating it with hydrochloric acid, the fluid is to be filled into capacious glass bottles, that can be closed with an air-tight fitting cork. This cork must contain two perforations, into one of which passes a so-called Welter's funnel, while the other one contains a rectangular glass tube, which is united by an India rubber tube to a metallic one ending in the ash pit of a fire place.

If sufficient hydrochloric acid is gradually poured through the Welter's funnel into the fluid, as long as a precipitate of silver chloride is formed in it, the liberated prussic acid escapes through the tube into the fire place, and is converted therein to carbonic acid, water and nitrogen. At the ending of the work, the funnel is brought into connection with a bellows, and air blown through the bottle, so as to move the last traces of said prussic acid; it is then opened and

the fluid decanted from the silver chloride, which is again worked into pure silver.

The employment of the galvanic current is by all odds the safest. A sheet of pure silver is suspended in the bath and connected with the zinc pole of the galvanic battery, while the copper pole of the latter is coupled with a sheet of platinum immersed in the fluid, the dimension of which nearly corresponds to that of the silver sheet. The silver contained in a dissolved state in the fluid now separates, after the current has operated for a little while, and clings to the silver sheet, the weight of which is proportionately increased. If the latter is weighed twice, after an interval of one hour, and if no further increase is shown, the bath may be considered as spent, and thrown away.

PICKLING THE ARTICLES TO BE SILVERED.

It is an indispensable condition for the success of the operation of both silvering and gilding, that the articles be introduced with an absolutely clean surface into the silvering and gilding baths; the slightest touch of the cleansed object, the settling of particles of dust, even, is already sufficient to prevent the depositing of the metal on the contaminated place. Since it is impossible to correct or improve an article defectively gilt or silvered by these methods, actually nothing else remains than to separate the metallic coating and to reproduce it anew.

The articles are cleansed in the same manner as already described for other operations of the same nature; by treating them with lyes and acids, it is sought to remove every trace of an organic substance from their surface. The work of cleansing begins by boiling the object in water in which about five per cent. solid caustic soda is dissolved; every trace of fat adhering to the surface is destroyed hereby. After the article has been immersed in the lye, it must no longer be touched with the hand, until completely silver or gold plated; it therefore must only be handled by tongs; smaller articles are best suspended by wires, several of them together.

The articles, after having been boiled, are withdrawn from the hot lye, at once rinsed well in clean water, and then dipped in nitric acid, which, in order to still increase it in effectiveness, is mixed with about ten per cent. of sulphuric acid, and such a bath is especially well suited for bronze articles that are to be gold or silver plated. Since so highly concentrated an acid operates very energetically, the article must only be dipped in and withdrawn quickly, after which it is first rinsed with common and then with distilled water. It is now immersed in a solution of protonitrate of mercury. A fluid is used for more delicate objects which contains, beside nitric and sulphuric acids, also a very small quantity of hydrochloric acid; for instance:

Sulphuric acid	parts by weight,	60 to 70
Nitric acid	" "	60 to 70
Hydrochloric acid	" "	0 5 to 1
Water	" "	60 to 100

The quantity of water depends upon whether pickling is to be done either very quickly or slowly; more dilute acids operate more slowly than concentrated ones; the hydrochloric acid is added for the purpose of introducing a small quantity of chlorine into the fluid, and to increase its effectiveness.

The articles, having been finally rinsed with distilled water, are now introduced into the solution of protonitrate of mercury, and remain therein until they are directly to be placed into the silvering bath. The articles, of whatever color they be, become lustrous tin white, by being coated with metallic mercury.

It is the opinion of many that it is also unconditionally necessary to scour the articles with sand, after they have been cleansed in the caustic lye, and before being introduced into the acid bath, for which purpose the finest sand obtainable is to be used; if it cannot be procured sufficiently fine, it must be washed. This scouring is not unconditionally necessary, and the articles may be cleansed perfectly by the use of the lye and acid bath, but it is of advantage in other respects. The entire surface of the article is covered with innumera-

ble fine scratches by the fine grained sand, and the silver coating is apt to adhere much more tenaciously to the underlying metal.

SILVER PLATING.

In order to distribute the silver plating quickly and with uniformity upon the surface of the article, even if at first only in the shape of a very thin film, it is customary to plunge it at first into a silver bath, after having been withdrawn from the mercury solution; it is then connected with the zinc pole of a very powerful battery, so that within a few seconds, a filmy silver deposit has been thrown down upon the surface of the article.

As soon as this has been effected, the article is withdrawn from the silver-plating bath, rinsed with water, and then brought into the bath in which such plating is to be finished. The article is left for a shorter or longer time in the fluid, according to the thickness of the deposit it is intended to have, and it is necessary to know exactly how much silver is thrown down in a given time, in order to determine hereby, whether plating has to be continued or interrupted. This can best be done by weighing a larger number, say a dozen, before suspending them in the bath, and again ascertaining their weight after a given time. The increase, divided by 12, expresses with sufficient exactness how much silver has deposited upon each single object.

By using the metallo-electric balance it may be determined beforehand how much silver shall be deposited upon the article in the bath. When this amount has been precipitated, the electric current is at once interrupted, and further precipitation ceases.

The principle of this contrivance is as follows: All the articles which are to be immersed in the bath are suspended from the balance beam; to the other end of the beam a plate is hung, into which the weights are laid, so as to counterbalance the articles.

To the end of the scale beam carrying the plate an iron pin is fastened, under which a vessel containing mercury is placed in such a manner that when counterbalanced, and a weight added of the quantity the silver coating is to weigh, this pin dips into the mercury. One of the wires coming from the battery is led into the mercury, the other one stands in connection with the sheet of silver in the bath, the electric current now passes from the battery into the mercury, from hence through the pin into the scale beam, and into the articles to be silver plated, and on the other side from the battery into the sheet of silver in the bath—the current, therefore, is closed by the bath itself and silver precipitates upon the articles. These, of course, will become heavier; when their weight has increased so much that they overbalance the weight in the scale plate, even if by a trifle, they will draw down the beam, whereby the pin is withdrawn from the mercury. The course of the electric current is interrupted hereby, and any further precipitation of silver ceases from this moment.

The operator has it entirely at his command before commencing to work, to determine by the use of this ingenious contrivance, how much silver shall be deposited, without the necessity of interfering with the course of process, by stopping to weigh.

The silver coating may either be precipitated in a mat or a lustrous condition; since the latter involves many difficulties, however, and mat surfaces are easily burnished with the steel, silver plating is most generally executed mat.

MAT SILVER PLATING.

Objects of art, especially statuettes and similar works, when mat silvered, are generally of a highly agreeable gray-white appearance, by which their beauty is very materially enhanced, but, unhappily, this soon changes in air. The cause of this rapid alteration is easily explained by examining the nature of the silver coating; it consists of innumerable microscopic crystals, between which dust quickly lodges; also in consequence of its large surface the object offers many places of attack to the operation of the atmosphere (sulphuret of hydrogen), and the consequence is that the article quickly tarnishes.

In order to retain mat objects lastingly handsome, they must, after

having been removed from the silvering bath, repeatedly be dipped into water, so as to remove all adhering traces of the fluid charged with potassic cyanide, because this would change the alloy lying under the silver coating. The article is finally dipped for a few minutes into boiling distilled water—after which it will dry very rapidly by itself.

It has also been recommended to coat such articles with a very thin protective layer, and an ethereal copal lacquer is excellently well suited for the purpose; the article will remain so much more durable in air. This otherwise commendable method has the serious drawback that the handsomest luster is deteriorated by even the most delicate coating, and, therefore, we cannot conscientiously recommend this process for objects of art.

We have found that it is better to proceed in the following manner. The article is silver plated as ordinarily, and the silver layer made pretty thick. Finally, as powerful an electric current as possible is applied, in order to rapidly precipitate a certain quantity of very fine silver crystals, after which, as far as washing is concerned, it is treated in the customary manner.

The silver coating adheres so firmly to an article that has been silver plated in this manner, that it may be cleaned with a soft tooth brush, without anticipating injury. Cleaning is begun by using feeble lyes, to be followed by a very weak sulphuric acid bath, when the article is finally boiled several times in pure water.

Mat silver plated articles, intended to be burnished, are, after having been rinsed and dried, burnished with the steel in the customary manner; it will be readily understood that the silver coating must for this purpose be made sufficiently thick. The galvanically produced silver coatings are very easily burnished, which fact may be explained by the porousness of the coating of chemically pure silver, produced by the electric current.

If articles are left at complete rest in the silver-plating bath, it will be found that larger objects, teapots for instance, become striped, and it is not easy to efface this by burnishing. This stripedness is caused by the fact that those parts of the fluid from which the silver was at that moment precipitated, become specifically lighter than those farther off, and rise to the surface, whereby currents are caused in the entire fluid, thus producing the stripes.

This disagreeable occurrence may entirely be prevented by introducing an arrangement into the silver-plating apparatus, charged with frequently imparting a shock to the articles immersed in the bath; a clockwork is very appropriate for the purposes of small shops, while large factories generally have a rotating machine, and the motor can be made to perform this duty.

LUSTROUS SILVER PLATING.

As previously stated, it is possible to produce a lustrous silver coating in the galvano-electric way, although connected with difficulties. It is a singular fact that a very trifling quantity of sulphuret of hydrogen in the silvering bath causes the coatings produced therein to assume a handsome luster. The cause of this peculiar occurrence, which was discovered accidentally, cannot be yet explained.

The sulphuret of hydrogen is employed in such a manner that from 30 to 35 grams of this fluid are poured into a bottle of from 10 to 12 liters capacity, which is then filled with newly prepared silvering fluid and shaken several times a day during the space of an entire week. A small portion of the sulphuret of hydrogen is hereby dissolved. A very small quantity of this silver-plating fluid, when added to the ordinary silver-plating bath, effects that the galvanically prepared silver precipitates as so lustrous a coating that a subsequent burnishing of the article is no longer necessary.

Other sulphur combinations, such as sulphur chloride, hypo-sulphurous soda, as well as a solution of sulphur in collodion, are said to produce the same effects as the sulphuretted hydrogen; but that it is not the sulphur, which in this case is alone the active cause, may be seen by the fact that a solution of iodine or gutta percha in chloroform is able to produce the same effects upon the silver-plating

bath. The quantities of these solutions, to be used on a certain amount of the silvering fluid, is very trifling. To 500 liters of the latter, from $\frac{1}{10}$ to $\frac{1}{2}$ liter of the fluid treated with sulphuretted hydrogen, are sufficient to impart to the bath for a certain length of time the property of effecting lustrous silver precipitations; a certain new quantity is to be added as soon as the luster of the silver coating diminishes.

But it is not by any means sufficient to pour this fluid into the silver-plating bath; many other things must also be complied with in order to obtain really lustrous coatings. Experience proves that for this purpose batteries must be used, consisting of a small number of elements, only composed of large plates, and the silver plating bath must be in a state of perfect rest—the most trifling jar at once effects that the silver coating becomes mat. For this reason the action of the apparatus must be interrupted only when no more silver is to be precipitated.

RESILVERING WORN ARTICLES.

Articles subject to a strong wear, of course, are worn off quickest at those parts most frequently handled. While, for instance, German silver spoons are barely attacked at the handle and inner side of the bowl, the silver is entirely worn from the outside of the latter, in consequence of the rubbing upon plates, and the appearance of such objects is anything but handsome.

The German factories of such ware purchase these worn articles at a certain price, and re-introduce them into commerce, after having been resilver-plated. The production of a uniform silver coating is possible only when the old one has first been entirely removed.

This desilvering and resilver-plating is done in one operation by the electro-chemical process. The work commences with assorting the articles in such a manner that those which are to be re-introduced as new into commerce, are separated from those on which the underlying metal itself has strongly been worn off. The latter are desilvered by themselves, and the remaining metal is then fused.

The articles to be desilvered are first purified in soda lye and next in a sulphuric acid bath, and suspended in an ordinary silver-plating bath. But the wires are not connected with the articles and silver sheet, as is done when silver plating, but the process is reversed. The silver adhering to the articles is entirely removed by this arrangement and deposited upon the silver sheet, and this dissolution of the silver is effected so completely that no trace of it remains adhering to the articles.

Having become satisfied that all the silver has been removed, the articles are left in the bath and the conduits simply changed; the reverse process now takes place again—silver is precipitated upon the articles and dissolved from the sheet.

(To be Continued.)

Important Discoveries.

Continued from page 47.

Pottery and Porcelain.—The manufacture of earthenware (the ceramic art) existed among the Jews as an honorable occupation, and the power of the potter over the clay as a symbol of the power of God, is described by Jeremiah, 605, B. C., chap. xviii. Earthenware was made by the ancient Egyptians, Assyrians, Greeks, Etruscans and Romans. The art which was lost at the subdivision of the Roman Western Empire, reappeared in Spain with the Arabs.

Pyx.—In the ancient Chapel of the Pyx at Westminster Abbey are deposited the standard pieces of gold and silver under the joint custody of the Lords of the Treasury and the Comptroller General. The "trial of the Pyx," signifies the verification of a jury of goldsmiths of the coins deposited in the Pyx box by the Master of the Mint.

Quadrant, the mathematical instrument in the form of a quarter of a circle. The solar quadrant was introduced about 290, B. C. The Arabian astronomers under the Caliphs, in A. D., 995, had

a quadrant of 21 feet, 8 inches radius and a sextant 57 feet, 9 inches radius. Davis' quadrant for measuring angles was produced about 1600. Hadley's quadrant in 1731.

Rhodium, a rare metal, discovered in platinum ore in 1804. It has been used for the points of metallic pens.

Rubidium, an alkaline metal discovered by Bunsen by means of spectrum analysis, and made known in 1861.

Sapphire.—A precious stone of an azure color and transparent; in hardness it exceeds the ruby and is next to the diamond.

Silver Coin.—Silver was first coined by the Lydians, some say the Aegians, in Greece, 783, B. C., others by Argos, 869, B. C. At Rome it was first coined by Fabius Pictor, 269, B. C. Used in Britain 29, B. C. The Saxons coined silver pennies, which were $22\frac{1}{2}$ grains weight.

Sodium.—A remarkable metal first obtained in 1807 from soda.

Spheres.—The celestial and terrestrial globes and also sun dials are said to have been invented by Anaximander, 552, B. C.

Standard for gold and silver in England fixed by law 1300. Standard gold is 22 parts out of 24 of pure gold. The standard of silver is 11 oz. 2 dwts. of fine silver alloyed with 18 dwts. of copper, or 37 parts out of 40 pure silver, and three parts copper.

Tantalum.—A rare metal discovered in American mineral by Hatchett in 1801.

Telescopes.—The principle was discovered by Roger Bacon about 1250.

Tellurium.—A rare metal, in its natural state containing quantities of iron and gold; was discovered by Muller in 1782.

Thermometer.—The invention of this instrument is ascribed to several scientific persons, all about the same time. Galileo's invention was introduced in 1507.

Thimbles are said to have been found at Herculaneum. The art of making them was brought to England by John Lofting, who set up a workshop at Islington about 1695.

Thorinum.—A very rare metal (a heavy gray powder) discovered by Berzelius in 1828.

Tin.—The Phoenicians traded with England for this article for more than 1,100 years before the Christian Era.

Titanium.—A rare metal discovered by Gregor in menakite, a Cornish mineral, in 1791.

Troy Weight.—The Romans introduced their ounce into Britain. The present ounce was brought from Grand Cairo into Europe about the time of the Crusades, 1095, and was first adopted at Troyes, in France, whence its name. It is used to weigh gold, silver and precious stones.

Watches are said to have been first invented at Nuremberg, 1477, although it is affirmed that Robert, King of Scotland, had a watch about 1310. Watches were first used in astronomical observations by Purbach, 1500. Charles V. is said to have worn the first watch. Watches were first brought to England from Germany, 1577. Regulating watches were invented by Barlowe, 1676.

Wedding Rings were used by the ancients, and put upon the wedding finger from a supposed connection of a vein there with the heart. According to Pliny they were made of iron; in the time of Tertullian, of gold.

Weights and Measures.—These and the stamping of gold and silver money were invented by Pheidon, tyrant of Argos, 895, B. C. Weights were originally taken from grains of wheat, the lowest being still called a grain.

Yttrium.—A rare metal discovered by Gadolin in 1794. It is of a dark gray color and brittle.

The Silver Wedding of the German Crown Prince.

THE SILVER wedding presents to the Crown Prince and Princess of Germany form a rich and attractive museum of creative and industrial art, and fill several rooms in the prince's palace. Hundreds of packages have not yet been opened. A few of the most prominent may be mentioned. From the Emperor and

Empress came a costly silver tea service; Queen Victoria sent her own bust, one of the finest works executed by Mr. Boehm, R. A. The silver wedding pair themselves exchanged presents—the offerings of the Prince being an original life-size portrait of a nobleman of the Vandyke period, with an ancient chain of gold, pearls, an old English soup tureen, and other things; while that of the Princess is a strikingly executed marble bust of herself. The gift of the British Ambassador and Lady Amphile consists of a pair of silver candlesticks and inkstands for a writing table, the members of the British Embassy contributing a double-branched silver candelabrum, with shades, a copy of one in the Windsor plate room. The surviving members of the Queen's household, as it was when the Princess Royal of England was married, have sent over an ornamental punch bowl, hall-marked at the time of George II.; while, perhaps, the most costly, and certainly the most imposing of all the presents, was a magnificent piano-forte, in the highest style of Rococo ornamentation, furnished by those members of the household of the Crown Prince and the Princess who have served them since their wedding. Many elaborate and costly presents came from friends in England. Of the presents from Germany the most noble and magnificent is a complete dining-room suite, except the plate, contributed by the chief cities of Prussia, and costing 67,000 marks. The furniture is of elaborately carved oak, and the whole has been devised and selected by a committee of artists and other experts with consummate taste. Nor have the numerous Germans residing abroad forgotten the future Emperor and Empress of the Fatherland. From America, Australia, New Zealand and Africa, loyal mementoes have been sent to Berlin. Perhaps the most conspicuous of all the offerings from abroad is a silver vase, about two feet high, beautifully chased with Chinese figures in the modern style, from the Germans of Canton. The Crown Princess' apartments were on Thursday littered with handsomely bound and illuminated addresses from corporations, societies, regiments, etc., with numerous sketches, paintings, and other offerings from Berlin artists; while all about lay countless rare and colossal bouquets, some of them beyond the strength of one man to lift.

In view of the silver wedding, subscriptions had been set on foot throughout Germany, but especially Prussia, by various societies, for the purpose of commemorating the occasion in different flattering ways. But the Crown Prince and Princess signified their preference for the disposal of these memorial sums as contributions, partly to the fund now being raised on behalf of the victims by the late inundations, partly to the hospitals of the capital, and partly for the founding and endowment of other benevolent institutions. For these purposes a sum of not less than 800,000 marks has been placed at their disposal by a central German committee. Out of their own private purse they have given 10,000 marks for distribution among the poor of Berlin. The city of Berlin itself has likewise voted the sum of 200,000 marks for charitable purposes, in commemoration of the event, and of this, 118,000 marks will go to the founding of an institution for tending the sick and wounded. The British Consul-General, Baron Bleichroeder, gives £1,500 for the building of an English church in Berlin.

The Cylinder Escapement.

[BY HERMAN SIEVERT.]

Continued from Page 40.

THE CYLINDER.

THE ACTIVE part of a cylinder is formed of a little more than one-half of a circle, and it must not amount to less than 196° , nor more than 200° . When the lifting plane passes with the center of its cord through the middle of the cylinder, 16° of the 196° remain for the necessary security of repose and for the rounding of the lips upon both sides.

The thickness of the cylinder wall must not be greater than is actually required for its necessary solidity. A thickness of not beyond the one-tenth part of the exterior cylinder diameter suffices,

so that eight-tenths of the latter remain for the interior diameter. The difference between tooth length and interval is prescribed by the wall thickness of the cylinder, which difference, of course, must be as much as the double wall thickness and the shake necessary for freedom of motion. A cylinder with too thick a wall would not alone have as consequence the diminution of the lifting planes of the wheel, but also the inequality of the repose levers, that means, the difference between the inner and outer radius of the cylinder.

The shape of the lips is more important than should be supposed by the trifling extent of the active face. They at first are to promote the issuing of the wheel from its repose, and for that purpose the corresponding two corners are slightly chamfered (fig. 4, plate 2). But the lips must then be of such a shape, that no single portion of it comes exclusively or preferably in contact with the inclined plane of the wheel tooth, but that the friction is divided as uniformly as possible upon the entire plane of the lips. If you study attentively the position of the lips to the inclination of the wheel tooth during the lifting, in fig. 1, you will find that the shape of the two lips cannot be the same, but must be formed as indicated in fig. 4. If the entrance lip, for instance, were shaped like the other one, then only the tooth point could touch the entire lip; the inclined plane itself would exclusively rub on the last corner, and soon cause a wearing at this place. If, on the other hand, the exit lip were shaped like the former, then the friction would occur on the fore corner, and the tooth, after having finished lifting, would leave the lip with a large drop upon the outer repose. In order to prevent the latter great drop, the inner corner of the entrance lip and the outer corner of the exit lip, must by all means not be chamfered more than is actually necessary for removing burr and sharpness.

Fig. 5 represents two badly shaped lips, which leave the tooth free. The entrance lip has the shape of a semi-circle; the exit one, on the other hand, is only a little more rounded than in fig. 4. But this trifling deviation of form suffices to render the last part of the lip valueless for the lifting, to largely increase the drop of the wheel, and, because only a small part of the lips is required for friction at the lifting planes, to hasten the wear of the lips.

THE OPERATION OF THE WHEEL TOOTH UPON THE CYLINDER. (TABLE II, FIG. 6.)

The cylinder, on account of simplicity, is here only drawn as an arc of 196° . The inclination of the tooth in the cylinder also is indicated simply by a straight line, since its shape has no influence upon the dimension of the lifting and the kind of rest. In order to understand what is here going to be said about lifting and repose in the tangent, it is necessary first to explain where the tangent of the cylinder circle lies, which is to be of moment for the operation of the wheel. The power of the wheel acts most favorably upon the circumference of the cylinder at that point where the tangents $a b$ and $c d$, drawn in the direction of the wheel radius, touch the cylinder circle and forms right angles with the radius of the cylinder.

If the repose were to occur at these points, it would reduce the friction to the most trifling quantity, and the tooth point then would have to pass almost through the center of the cylinder. But by this arrangement, the entire lifting would, in a decidedly unfavorable manner, be located beyond the point of contact of the tangent, and this defect by far overbalances the advantage of a friction upon the repose in the tangent. This consideration, together with practical experience, has led to an arrangement by which the center of the straight lifting plane, or in case it should form an arc, then the center of its cord, passes through the center of the cylinder. Consequently, this cord, when the tooth is within the cylinder, coincides with the radius of the cylinder. Now, since the radius is the longest straight line within a circle, this arrangement permits also the greatest possible length of tooth. The dotted outline of a tooth in fig. 6 will explain that by placing an action deeper the tooth must be shorter, and in consequence of which the outer tooth drop would be proportionately more than the inner.

The correct position of the tooth, also represented in fig. 6, requires

at the same time the extension of the operative part of the cylinder. By an escapement part of so small a diameter, the tooth must at least fall from 5° to 6° upon repose, because, on account of security, the necessary side shake of the pivots must be duly considered. If we still count the 10° rounding of the small lip, and what is lost in degrees of lifting by the somewhat smaller length of tooth actually necessary, we will obtain for that part of the cylinder left standing an extent of at least 196° up to about 200° . The points where the tooth falls upon repose are indicated by *a* and *b*, fig. 4; the repose increased there somewhat by the altered shape of the large lip, say about 10° , but this greater repose has no influence whatever upon the action.

The inclination of the tooth drawn in fig. 6 amounts to 18° ; the rotation of the cylinder effected by this inclination is indicated by the dotted prolongation of the cylinder circle, and amounts to double, or 36° . In reality this will not be so much, because you will easily see that only in a sketch the tooth can fill the entire interior of the cylinder, and this again the entire interval between two teeth. A little shake must really be present for free motion, and the tooth must consequently be made a trifle shorter. By this shortening of the lifting plane, and by the operation on the larger lever of the small lips toward outside, it is apparent that the lifting becomes somewhat smaller. If we count to this the lifting produced by the rounding of the lips, then the entire lifting will amount to about 38° or 40° , by an inclination of 18° . The total motion of the cylinder from one drop of the wheel to the other, consists of lifting and repose, and will consequently amount to about 46° to 50° in this case.

You will see by the dotted motion of the cylinder (fig. 6), that a somewhat smaller part of the lifting occurs before than behind the point of contact of the tangent. But if the lifting were to be distributed equally, then the repose would operate still more obliquely against the cylinder wall. You will see, therefore, that by the present arrangement a favorable mean way has been chosen in this regard.

THE PROPORTIONS OF THE CYLINDER ESCAPEMENT INFLUENCING ITS REGULARITY.

The motion of the cylinder and balance is accelerated during lifting by the power of the wheel; after its completion, however, it is retarded by the friction upon repose. This retarding will augment in proportion with the thickening of the oil, and only such a cylinder watch can preserve its rate unaltered, in which, by the thickening of the oil in the pivot holes of the wheels, etc., the power of impulsion becomes weaker at the same time, and the retarding is counterbalanced by a lessened extent of the vibrations and friction planes. It is clear that for this counterbalancing between acceleration and retarding, a corresponding thickness of wheel pivots is necessary, and it is a fact long ago known in practice, that a watch with unduly thin wheel pivots goes incorrectly. For the same reason, these pivots in 8-jeweled movements must be somewhat thicker, because the friction does not otherwise increase in a corresponding ratio in the thin and smooth jewel holes with the thickening of the oil. But beside this, as we will soon see, a well-determined size of escape wheel is necessary for maintaining the stated equipoise. For good reasons, the scape wheel is not easily chosen too small, on the contrary, an endeavor will often be noticed to make it as large as the size of the fourth wheel permits. This is wrong, for the simple reason even, that a larger wheel, with its increased measure and longer radius, is with more difficulty set in motion, and more power is necessary to overcome its inertia.

Let us suppose that a cylinder scapewheel be twice as large as a wheel of correct size. Of course, the cylinder must always stand in the same proportions to the wheel, and consequently be also twice as large. It is well known that with an equal motive force the power operating upon the circumference of a wheel decreases in the same ratio with the length of its radius. Wherefore, the scape wheel, twice as large, operates with half the power upon twice as long a lever arm

of the cylinder, consequently without considering the aforesaid resistance of the inertia, the power of the propulsion has remained unchanged. But it is different with the friction upon repose. Although the tooth point operates only with half the power upon the repose radius of the cylinder twice as long, but the extent of the repose plane is twice as large by an equal extent of vibration. The effect of this larger extent will be that the retarding by the repose will overbalance the accelerating of the balance by the impulse, and the rate of a watch will, after a while, increase sensibly. The correct size of a scape wheel, however, can almost not be ascertained by calculation, and even a diameter found by practical trials does not answer for all watches of the same size, since many other circumstances must be drawn into account for a continued good rate, for instance, the breadth of the mainspring, the inclination of the teeth, the thickness of pivots, and the size and weight of the balance. As already said, however, the measure of the smallest admissible size of the scape wheel is not easily surpassed, although too small a wheel would exert an injurious effect upon the pivots by too strong a pressure.

THE BALANCE

Must stand in a definite proportion to the diameter of the cylinder. Its regulating power especially lies in its possibly largest circumference; by too great a weight near its center, the friction on the pivots is unnecessarily increased. Equally so, too small a balance, even if sufficiently heavy, is far more influenced by the accelerating and retarding than a larger one, while, by equal weight of both, the pivot friction produced by its pressure remains the same. The size of the balance is limited by the so-called "setting" (the defect of a watch which will not start of its own accord, when wound up, is called by this name). A larger balance requires a larger power of the balance spring, and this is to be surmounted in the beginning, lifting by the power of the scape wheel. Experience has established a size of balance, the diameter of which stands to that of the cylinder as 16 : 1. A smaller balance does no longer produce a good rate, it may rather exceed this somewhat. The correct size of the balance in a watch is easily recognized that with otherwise suitable proportions of wheel and cylinder, the teeth of the former are barely visible beyond the circumference of the balance.

Also the weight of the balance is limited on both sides. Too light a one is subject in its regulating action to very disturbing influences, similar to too small a one, and, beside this, its vibrations easily become too large. Too heavy a balance acts like one too large, causing the so-called "setting." You will easily learn to estimate the suitable weight by a little study and attention; but as already said, the greatest possible portion of the mass must lie in its circumference; both arms and eye must be as light as is consistent with the solidity of the metal.

A special alteration of effects still takes place with smaller watches, of about 40 mm. diameter of plate. The regulating power of the balance decreases much more quickly by a uniform diminution of all parts than the force of the mainspring. But since the balance cannot be made larger, on account of space at disposal, and its increased weight would entail the error of an undue pivot friction, the height of the lifting planes is made larger, in order to secure, by the increased lifting of the power of the mainspring a greater continued influence upon the motion of the balance, as opposed to the greater retardation caused by the friction of the balance and pivots. You must therefore not consider it an error if in a lady's watch the inclination of the teeth should amount to more than 18° . Since, similar to the regulating power of the balance, also the strength of the balance spring decreases far more rapidly than the strength of the mainspring, the increased lifting is easily overcome by the latter.

THE CORRECTION OF THE CYLINDER MOVEMENT.

First examine in the double caliper, after having removed the balance spring by taking down the collet, whether the cylinder runs truly round at its operative parts and pivots. An untrue cylinder causes a motion of the wheel while lying on repose, and no correct

rate is possible in such a case. If this is only due to bent pivots, straighten them by means of a good tweezers without cut. But if the tampons are turned in untrue, they must be replaced (which see farther on). Next test the equipoise of the balance in the poising tool. The poising in the double calipers is less trustworthy. Next investigate pivots and holes. The former must be well polished, and fit thus into the holes that about one-sixth of the hole diameter remains as side shake. Choose the thickness of the cylinder pivots equal to $\frac{1}{8}$ or $\frac{1}{10}$ of the cylinder diameter. For a watch of 40 mm. (18 lines) will be necessary a cylinder pivot No. 10 of the pivot gauge, and a hole in which a pivot No. 12 just enters. Of course, it is presupposed that the jewel hole sits straight, and the hole is vertical to the plate. A cylinder pivot which enters sufficiently free can even, after a while, occasion the standing still of the watch as well as other errors of rate. In order to be very certain about the side shake of the pivots, construct a special pivot gauge, made according to the numbers of the pivot gauge.

In order to investigate the escapement, mount all wheels from the center wheel to the scape wheel. The lower cylinder cap jewel must be screwed firm, but remove the upper one, together with the whole regulator contrivance. Then mount also the cylinder, and examine at first whether the lower pivot rests upon the cap jewel, and that the shoulder does not approach too closely to the jewel hole. Loosen the cap-jewel screw for this purpose, and examine if the cylinder raises up sufficiently by pressing upon the set cap jewel. Should this not be the case, or if the cap jewel lies perhaps rather deep, file the brass face straight with it. Perhaps the jewel hole may also lie too deep, in which case the sink in the bridge must be turned deeper nearly to the jewel. Should the pivot be too short however, that is, not protrude sufficiently far through the jewel hole, then the shoulder must be turned farther back, a piece of work which, by the aid of the safety roller, is not very difficult. A loosely fitting cap jewel, or a burst one, must always be replaced by another one. The upper cylinder pivot must in an equal manner protrude sufficiently far through the appropriate hole that a sufficient portion, at least equal to its thickness, protrudes beyond the bridge surface.

A second very important point is the correct placing of height of the cylinder; no scraping whatever of the wheel bottom in the cut must possibly occur. In order to place the cylinder lower, in case of necessity, it is permissible to produce small burr on the inside of the lower bridge with a three-cornered pointed punch, in case that the bridge does not already reach up to the dial. The hammering of burr on the sides of the bridge disfigures it, and is not allowed. If the cylinder stands too low, deepen the sink of the plate by turning. It is always better, when the cylinder pivots are too long, to shorten and correct them by turning. This should always be done with the upper pivot, because an alteration of the resting face of the bridge always provokes its unsteadiness, and does not proclaim a good workman. The endshake of the cylinder should, like that of the scape wheel, be scant, so as not to endanger the free passage of the wheel bottom in the sink. It might happen with a very broad sink that the tooth slips under the sink face. Of course, such an accident must be carefully guarded against. Next follows the examination of the depth of the escapement. Of course it is not possible to ascertain, by a simple eye judgment or measurement, whether the lifting plane passes with the center of its chord through that of the cylinder, but this is best judged after repose. For this purpose insert a small piece of paper under the balance and propel this slowly as far as the drop of the tooth, by driving the center wheel with the finger. If next you move the cylinder backward, until lifting, you will by a little practice easily be able to judge whether the necessary repose is present. Let it serve you as basis that for a repose of 6° , as must generally take place at the small lip, a motion of the balance at its circumference equal to the one-twentieth part of its diameter is necessary, from the drop of the tooth until back to the commencing lifting. A point on the circumference of a balance of 16 mm. must therefore, according to this statement, move about 0.8 mm. You will remem-

ber that the exterior repose by the correct shape of the lips amounts to a little more, wherefore the observation of the repose at the small lip about suffices. In order to be very sure how many degrees repose must be present by a correct depth of depthing, you may measure the operating part of the cylinder, that is, the distance of a straight line located over both lips from the opposite exterior wall of the cylinder. This can be measured with a Glasshütte decimal gauge, better by all means, however, is a micrometer. The proportion of the cylinder diameter to the active part is, by 196° , as 100 : 57; by 200° , as 100 : 58.5. Of course, with a cylinder of 200° , the repose must be 2° more than by one of 196° , if the tooth is to pass sufficiently deep through the cylinder. With regard to the depthing distance of the cylinder escapement, this difference is in general so small that one may be satisfied with an approximately correct opening of the cylinder, to have regulated the repose on the small lip with 6° .

But too much repose is just as carefully to be avoided as too little, because the former, beside the already stated disadvantages, produces the "setting" of the action. Too shallow an action, on the other hand, produces a small vibrating arc and an irregular rate. The placing deeper or shallower of the action is effected by the lower movable cylinder bridge. If necessary, room for its motion must either be filed or turned. Next make a little room for the foot pins by means of a tapering chamferer, and bend them in the required direction. Should the screw not have sufficient shake, on account of the displacement of the bridge, enlarge both hole and sink to the corresponding side.

(To be continued.)

[Special correspondence of THE JEWELERS' CIRCULAR.]

A Trip to the South African Diamond Mines.

CAPE TOWN, *January 3, 1883.*

SOUTH AFRICAN SKETCHES.

Mr. Editor: The traveler coming from Europe, and shaping his course for the diamond fields of South Africa, has three routes at his disposal: First, a western one, which carries him from Cape Town per railroad to Beaufort West in twenty hours, and from hence after a travel of four days in a stage coach, drawn by mules, to the end of his journey; second, an eastern one, which, starting from Port Elizabeth (Algoa Bay), by way of Cradock and Colesberg—therefore through the eastern province of the Cape Colony—to the Orange River, and from hence through the territory of the Orange Free State, conducts him to the mines in six days; and thirdly and lastly, a third middle route, which, also using Port Elizabeth as starting point, cuts through the midland districts, that is, those situated in the middle between the Atlantic and the Indian Oceans—passes over the Orange at Zoutpansdrift, by which the voyager reaches the mines in about the same time. As for me, being a resident of Graaff-Reinet, the largest town of the aforesaid Midland Territory, I could only make use of the latter route, and therefore, on a fine morning in February, 1880, I mounted "Her Majesty's mail coach," a fragile box balancing upon two immense wheels, by means of which mail packages, frequently to the value of many thousand pounds sterling, are expedited for hundreds of miles in charge of a drunken negro. Day barely dawned when I took my seat upon the shaky "car," back to back with my sable driver, between packages and sheaves of oats, for feeding our horses. A quick clack of the tongue and a crack of the powerful "sgambok," a whip consisting of the hide of either hippopotamus or rhinoceros, and I found myself speeding along on the road toward the South African Golconda, for which I yearned. The lovely town of Graaff-Reinet, not unaptly named "gem of the desert," because, with its admirable gardens, in which, "within its dark green leaves, bright oranges do glow," it appears like a jewel in the midst of the disconsolate brown and gray of the surrounding heights—has soon disappeared from our view, and the sterile African "Karoo"—a plain thinly covered with grass and low bushes, the

monotony of which is only here and there relieved by isolated groups of prickly mimosa and acacia, the aloe with its fiery red flower, and by a few trailing plants—now surrounds us with its oppressive silence, barely ever interrupted by the twittering of a bird or the murmur of a running brook. Straight ahead of us is visible the mountain chain of the "Sneeuwberge," the southern encircling mountain of the South African plateau stretching far toward the north, while eastward we may follow the course of the Sundays River, which at present only constitutes a small and shallow water course, while after rains it swells into a powerful torrent, and rushes along with a thundering noise. "Rivers without water, birds without song, flowers without scent," are the epithets with which the Englishman has branded South Africa, and he has not been very wrong; the streams dry out entirely if it has not rained for a few weeks or months. But along! After a journey of one and a half hours, through the plain stretching to the north of Graaff-Reinet, which undoubtedly was once the bed of a very large inland lake, we have arrived at the foot of the above-mentioned Sneeuwberge (after the Drakensberge of Natal and the Mont aux Sources of Basutoland; the most important mountain of South Africa), and now our small and insignificant looking horses exhibit a specimen of their strength and perseverance, since, without resting, they drag the heavily laden cart, together with its live load, up the steep, serpentine road, to the one side yawning abysses, to the other sky-piercing rock wall, until arrived at the top of the mountain. The height of the Oudeberg (this part of the Sneeuwberge is called thus) is finally reached, where we find a one-story house, built of uncut stone, and euphemistically called "hotel." While our black postilion unhitches the foam-covered, perspiring coursers and strings in the relief horses stationed here, at short intervals moistening his parched throat with libations of the inevitable "brandy and water," we have stepped to the brink of the precipice, and let our glance roam to the right and left over the various mountain masses of which this mighty chain is composed. The first peculiarity that strikes our attention is their regularly returning table form—perfectly flat on top, with steep sides—the now higher, now lower, now smaller, now larger spurs reminding the beholder of the detached parts of a fortification, and the regularly returning contour of which is only interrupted here and there by a few sugar-loaf cones, round on top, the so-called "Kopjies," or "Loskopjies," (knobs, loose knobs). Perhaps there is no country on earth in which the stratifications of the sedimentary rocks, which elsewhere have been broken, pierced through and turned topsy-turvy in such a manner that the lowest stratum has become the highest—and in which these strata, originated from the sediment of the water, have so much retained their original shape and position as in South Africa, and where the horizontal stratification of the sandstone and clay slate masses, rendered visible on mountain declivities and valley openings, the rocky walls rising perpendicular from the plain, and the deep sea cliffs, washed out by mountain streams, represent in so forcible a manner, to the eye of the non-geologist, even, the powerful influence which water has exerted upon the formation of the earth crust, and still exerts.

But our time is too precious to be wasted in studying the shapes and forms of South African mountains; the crack of the whip of our Jehu, who is ready to start, reminds us that it is time to assume our seat upon the cart, and in a few minutes more we are jogging again over the high plain spreading before us. Everywhere the same scant vegetation, everywhere the same dreary desert. It might almost be believed that these lands were without owner and uninhabited, if not here and there, separated from each other by wide intervals, low farm houses could be espied; at the same time, there where the ground of the plateau arises into a hill, bright points become visible, which, when drawing nearer, we perceive to be sheep and Angora goats. Once and awhile we meet with an ox-wagon, which long ago has announced its coming by the cracking of whip and the screeching of wheel; it is drawn by a long team of powerful draught oxen, and is an uncouth vehicle, resembling the German ox-wagon of the last century; sometimes loaded with heavy goods, and sometimes sheltering

an entire family under its linen canvas, and is of the same significance to that part of South Africa, still uncontaminated by the presence of a railroad, as the ship is to the sea, or the camel to the desert. Agreeably surprised to meet with a human being in this solitude, we heartily respond to the "Goeden dag, Baas!" with which the black, leading the foremost span of oxen by the rope, salutes us in Cape-Dutch jargon, and the stiff, measured inclination of the head of the Boer, who, from the high driver's seat, impels the team sideward with his bamboo whip, thirty or forty feet long, to accord us necessary room to pass.

For this monotony the traveler is partly rewarded by the diversity of the fauna. We will not stop to examine and describe them in detail, however.

With these contemplations we have reached the little town of Hanover. We are glad to quit our seat in the mail cart, which, as far as comfort is concerned, can best be likened to the rack of the middle age, and, seated in the somewhat more comfortable two-wheeled vehicle, also drawn by four horses, we hasten toward the Orange River, generally called "Groot Revier" (large river) by the Boers. It is crossed at Zoutspansdrift; on this, the northern bank, we now find ourselves on the territory of the Orange Free State, which was founded at the same time with Port Natal and the Transvaal Republic by those Boers who became dissatisfied with the British regime in the years 1834 to 1838, which caused them to leave the Cape Colony to settle in the wilderness.

So we jog along, and while lost in contemplation, we are suddenly aroused by the shout of the driver that we are approaching the end of our journey. A few hours after we have passed Modder River, and just as the sun is about to set, the large tent and barrack town, Kimberley, comes into view, where we intend to reside for some time.

Before I proceed to describe to your readers the life and turmoil near and within the African diamond mines, it is necessary to preface it with a few remarks on their geographical position. The diamond fields, since their annexation by the British crown called Griqualand-West, are about 1800 meters above sea level, about 746 miles from Cape Town, under the 29th degree south latitude and 25th degree east longitude from Greenwich, and are bounded on the south by the Cape Colony, on the east by the Orange Free State, while the territory of the Betjuani tribes and the edge of the great Kalahari Desert form the northern and western boundaries. The Vaal, before it unites with the Orange, divides this tract of land into a smaller eastern and a larger western part. The existence of diamonds on the banks of the latter river appears to have been known for a long time to the aboriginies, but gradually it dropped into oblivion. The Bushmen had a tradition that their ancestors from the Kalahari Desert made frequent journeys to the Vaal, to find hard, white pebbles, with which to bore holes in their flint axes. The first actual discovery dates from the year 1867. The little daughter of a farmer living near the mouth of the Vaal, while playing on its banks, picked up a number of pebbles and carried them into the tent serving as abode to the family. A lustrous crystal among them excited the curiosity of an Irishman, O'Reilly, who was journeying through the region as trader. At the proposition of O'Reilly, the stone was sent to a Dr. Atherington, in Grahamstown (Cape Colony), who recognized it as a diamond of the purest water. Soon after, the celebrated "Star of the South," made its appearance, that beautiful diamond of 83½ karats, which a ragged Kaffir had picked up two years before on the banks of the Orange, and worn it as a talisman against disease. He offered it to an English merchant, who did not suspect its value, for a few yards of calico, but was refused. He finally traded it off to a farmer for a span of oxen and two hundred sheep, (a total value of about 300 pounds sterling), from whom it passed into the possession of a firm in Hopetown. That the news of these finds created a great excitement in the colony, which, on account of a few dry years and the sinking in price of wool, was near bankruptcy, need barely be mentioned, and already within a few years

afterward, enterprising men collected from all parts of South Africa, Europe, California and Australia, in order to risk the hazard of diamond digging in the new Golconda on the banks of the Vaal. Thus it came that already in the year 1871, the population of the diamond fields surpassed 50,000 souls. The first diggings were opened in the bed of said streams in 1869, miners having been satisfied until then with picking over the surface of the ground, and from this time date the settlements Pniel and Klipdrift, each one of which counted from 8,000 to 10,000 souls at the flourishing of the river diggings. Notwithstanding that the yield of diamonds found here among the washings of the river and mixed with jasper, chalcedony, and agate pebbles, feldspar and olivine crystals, was a very large one, and notwithstanding that the diamonds taken from the bed of the Vaal are all distinguished by the purity of their water, still these mines were entirely crowded into the background by the finds in the dry mines, the reports from which bordered on the incredible. These "dry diggings" were situated from six to seven miles from the Vaal, especially upon De Beer's New Rush, as well as upon the farms Dutoitspan and Bultfontein, and the above-mentioned settlements were almost depopulated.

Our next attention is directed toward the geological formation of the most important of these mines—the afore-mentioned De Beer's New Rush, a few years afterward called for the English Colonial Minister, Kimberley. Let the reader imagine a low hill, flattened on top, the surface of which is surrounded by a low stone wall, the "reef" protruding somewhat beyond the surface of the top. This reef, consisting partly of a rapidly slaking clayey slate, sometimes of a green, at other times yellow and brown marbled color, else partly consisting of the so-called "ironstone" (a crystalline volcanic rock, apparently identical with green stone, and universally spread all over South Africa), shows everywhere, where the former kind of rock is preponderating, a well-pronounced stratification, in such a manner that the strata dip at an angle of from 15 to 20 degrees to the horizontal plane toward the periphery of the "Kopje" (hill-knob). Toward the interior of the hill the reef slopes generally at a very steep angle, whereby the mine appears like a basin inclosed by a stone wall. At New Rush this basin is of an oval shape with a length diameter of 900, and a breadth diameter of 630 feet, and passes at its north-eastern end into a contracting prolongation. The basins of the dry diamond mines (not alone those already mentioned: De Beer's New Rush, Dutoitspan, and Bultfontein, but also Old De Beer, Coffeefontein, and the Jagersfontein situated near Fauresmith, in the Orange Free State, and a few others, all consist of basins inclosed by stone walls, and either round, oval or irregular in shape), are filled with a tufa-like mass, generally grayish-blue or grayish-yellow colored, which, as already remarked, is suddenly cut off by the reef, and differs essentially, as well by its peculiar structure as the mineral enclosures, from the red sand-like alluvial bottom of these regions, and generally from all rocky and earthy formations of the South African table lands. Regularly is found in the grayish-blue tufa, which represents the actual matrix of the diamond, and called "blue stuff," or "diamond-holding stuff" by the miners, fragments of the already described reef-forming, clayey slate, also those of other slate kinds, of sandstone, and "iron stone," here and there, perhaps débris of hornblende, mica, garnet, olivine and others; the diamond-holding mass, on its surface, is also covered by a stratum of the aforesaid calc-tufa, which, as well as the red alluvial sand, has penetrated through cracks and fissures down to a considerable depth. Remarkable, finally, are those large rock boulders, occurring in the middle of the diamond basins (in New Rush at a depth of 28 meters, in Old De Beer's mine stringing from one side of the basin to the other), called "floating reef," by the digger, and generally consisting of iron stone.

Reserving to myself the privilege of recurring to the geological formation of the diamond mines, I will first explain here the manner of diamond digging. The mine (the space enclosed by the reef) is divided into a number of claims of 30 feet square each. These

claims,* frequently only the one-half or the one-fourth part of such a one, are now by the owner of the ground sold to the digger, who then works them by the assistance of his black workmen or partners. Surrounding the cliff, scaffoldings of beams and boards have been erected, from which heavy wire ropes lead into the depth. On these ropes are suspended the buckets which bring up the "stuff" dug in the claims, and deposit it on the scaffolding, from whence it is carried in wagons to the sorting place, where it is sifted and assorted. Formerly, for the purpose of hauling the stuff away, narrow streets had been left between the claims, but the deeper these mines were worked, the more dangerous became the streets, until they finally represented narrow strips of ground encompassed on both sides by yawning gulfs, and repeated accidents occurred, brought about chiefly by the miner's well-known carelessness. It was therefore deemed best to give up the streets and parcel them out into claims.

A circumstance that renders the working of these mines very difficult, is the collection of water in the claims after each tempest, which rage with incredible fury during the summer months, frequently filling the mines up to the very brim, so that the steam pumps must labor night and day. The mining basin, excavated to a depth of about 150 feet, on days when no work is performing, lies dreary and desolate, and viewed at night it appears like bastions of a fortification destroyed by the enemy. Entirely different, however, is the bustle on working days. The raising and lowering of buckets, the clatter of rollers and blocks and tackle, the innumerable workmen that swarm like ants below in the depths—all this constitutes a picture forcibly calling to mind the active life of a beehive, and the muffled thud of spade and pickaxe, arising from the depth, is occasionally interrupted by the joyous exclamation of a lucky finder or the warning cry of the Kaffirs that a part of an earth bank is about to cave in, threatening death and destruction to the workmen in the adjoining claim.

I spoke of the business of sifting and assorting. While the water in the river excavations near Pniel and Klipdrift is used for washing the diamantiferous gravel and clay, the assorting of the "stuff" in the dry mines is performed by simply throwing aside the larger hardened conglomerated lumps of the diamantiferous earth, since it would consume too much time to crush it, while the other "stuff" is passed through sieves of decreasing fineness. After the pebbles from the coarse-meshed sieves have been subjected to a hasty inspection (the educated eye of the assorter detects a diamond of a larger size at once), the last remaining gravel is spread out upon a table lined with sheet iron, and the diggers, grouped around it, each draws out a *quantum sufficit* of the diamantiferous stuff with his iron hooks, which, after having been inspected, is thrown under the table. The visitor would think it hardly possible that a few handfuls of "stuff" can be spread apart with a motion of the hand and inspected in one moment, and the therein contained diamonds be recognized; it is almost incredible, how much the acuteness and quickness of the eye has been perfected by the continual exercise, so that by this apparently superficial inspection, generally only very small and comparatively worthless diamonds escape the assorter's eye. Not unimportant is the yield often furnished by the hardened pieces. They become very soon friable by the combined action of the sun and rain, and the Boers' daughters and children frequently reap rich rewards for their trouble of culling the mass.

The cape diamond possesses a few peculiarities that distinguish it from its Brazilian or Indian brothers. For instance, among the diamonds of the dry mines, many are found with a yellowish color, or off-colored, sometimes even with a black or green tinge. And, unhappily, the larger stones possess this color, whereby their value is seriously decreased. On the other hand, stones are sometimes found, the outer layer of which simply is colored black cloudy, and they were at first not considered diamonds, while when cut they develop into the most valuable specimens.

* The New Rush mine was some years ago purchased by the government of Griqualand-West, and is at present worked by an English Company that has purchased the right of working nearly all claims.

A second peculiarity that characterizes the Cape diamond is, that the number of large ones is relatively very great to that of the small ones. Only fifteen years ago a ten-karat diamond still represented a small fortune. Since the discovery of the Cape mines, in which ten and twenty-karat stones are found daily, value proportions have altered greatly, and while formerly the value of a large diamond was estimated as increasing in square of its weight, it is at present simply computed at so much a karat, without reference to the weight of each individual stone. It is well-known to the reader that of late years the New Rush Mine has furnished stones of a weight of 115, 144, 166, even as high as 288 karats—diamonds which, if they did not possess that yellowish tinge, would eclipse the celebrated "Koh-i-noor," the "Regent," and other famous crown jewels.

(To be Concluded.)

Electro-Gold and Silver Plate.

BY JOHN W. MILES.

THE ART of covering an inexpensive material with one of superior value is of great antiquity. The boards, bars and pillars of the Tabernacle, and even the Ark itself, were made of shittim-wood "overlaid with pure gold," a class of handiwork that the Israelites possibly learned from their taskmasters, the Egyptians. The same principle is applied to-day in veneers, emerald doublets, velveteens, brown stone front houses, and more prominently in gold and silver plated ware. In the production of the latter a new element has been employed within the last half century—the peculiar element of electricity—whereby more satisfactory results have been obtained at the expense of less time, labor and waste. The effect of this practical application of a scientific discovery has been natural and positive. Plated ware has largely superseded solid silver, to which it is inferior only in intrinsic value, and, owing to its reduced cost, there is hardly a home, however humble, unable to boast of one or more pieces of it. Even in wealthy families the solid ware is sent to the bank vaults for safety, being displaced by electro-plate for daily use. In a paper read before the East India Association, January 18, 1882, by Edward J. Watherston, Esq., he says: "I am aware that it may rightly be argued that there are manifold reasons for the decline in the silver trade, viz.: the *admitted fact that electro-plate has, in a large measure, supplanted silver plate*; that the cost of the former, even of the most expensive description, is far less than that of the latter, and that a great number of persons, although fully able to purchase articles of great value—such as diamonds and other precious stones, pictures and articles of vertu—*prefer electro-plate as being less liable to robbery*. Country people of *highest rank and property* frequently offer these objections to the use of silver plate." (Italics mine). If this be admittedly true of England, with its aristocratic pride and prejudices, what can be said of the United States, with its democratic practicality?

Probably there is no other product of such great importance and in such universal use of which so little is known regarding its manufacture. Literature upon the subject is extremely meagre, and limited largely to workshop recipes and Patent Office Reports. The supplanting of the old methods of "rolled" and "hand" plating, the improvements in machinery for metal working, and the invention of new and more perfect electrical appliances for this special purpose, appear to have no connected and distinct history of their own. This is doubtless due to the comparative youth and rapid development of the art. It is the design, therefore, of this essay to give a concise and popular description of the present processes, with a brief account of such steps leading thereto as may be immediately available.

The time is still fresh in the minds of the people when the "Sheffield" ware bore, all over the world, a preëminent reputation for quality. Its fame was certainly deserved, but the production was necessarily limited and costly. At that stage the hammer was the main tool of the workman—the eye and hand performing much of

the labor now more perfectly and quickly accomplished by machinery. Copper was the metal principally used as a base. It possessed the qualities of ductility, tenacity, resonance and a facility of receiving the silver coating, as then applied, in a greater degree than any other pure metal of relative cheapness. In most cases, however, the copper was used only in the body of the articles, the mountings and trimmings of the finest ware being of either solid or filled silver, substituted in the cheaper grades with lead. The methods of plating were by both the "rolled" and "hand" processes. Rolling is now rarely if ever applied in silver plate, although it is still extensively used in plating jewelry with gold. There were two kinds of rolled plate, viz.: "double" and "single." The former was obtained by rolling a plate of copper, or any other metal capable of bearing the necessary heat, between two plates of silver. These plates were either welded or simply united by placing their hot and clean surfaces together, moistened with a concentrated solution of nitrate of silver. They were then reduced or drawn out by rolls to the required thickness, the two metals bearing constantly the same relation to each other. The result was a large sheet of silver-coated metal which could be cut and worked into the shape desired. "Single" rolled plate, as its name implies, was coated with silver on one side only, the custom being to tin the reverse side after the completion of the article. Besides the very important items, in manufacture, of time and labor required in the rolling process, it had other serious objections. Cutting the prepared sheets naturally exposed at the edge the copper base, requiring additional labor to cover and conceal it, and the difficulty of preserving intact the silver covering upon deeply indented ornamental surfaces necessitated the use of solid silver as before mentioned. Also in embossed or *repousse* work the raised and most exposed portions bore a coating of silver slightly thinner than upon other parts less subject to attrition. In the electro-process this result is exactly contrary.

"Hand" plating was applied after the article had been finished in the metal base, when it was treated as follows: After a nitric acid bath, which produced in the article a multitude of minute holes, as points of attachment for the silver, it was heated to about 300° F., to open the pores of the metal. Silver foil was then laid upon its surface and pressed to its place with a soft pad. The article was finished by burnishing. In plating with silver foil the silver had less adhesion than by rolling, and was applied principally to pieces of the larger size.

These two modes of silver plating were in vogue before the advent of electricity revolutionized the art and gave to it an impetus beyond parallel. By the employment of that mysterious and, as yet, unexplained power, the manufacture of silver plated ware assumed a growth marvellous in its rapidity and strength. Constant improvements and inventions prove that the limit of usefulness for electricity is still far in the future, yet with all the remarkable developments of the recent past the electro-plater has not been idle, but, pressing forward step by step, almost treads upon the heels of the scientist and experimenter.

With the inauguration of a new method came the utilization of other metals than copper as bases, nearly all the new materials being alloys or "made metals." It was found that brass, an alloy of copper and zinc (copper 80, zinc 20), could be easily plated by the electro process, and being a metal harder than copper, by reason of its zinc alloy, it seemed more suitable for the smaller articles. It gained little favor, however, among reliable manufacturers, and of late years it has been abandoned almost entirely to the makers of cheap and worthless goods. German silver, or "nickel silver," also came into prominence as a base, and it is to-day the best and most durable in use. It is a silver-like alloy of copper, zinc and nickel, the best proportions being copper 51, zinc 30.6, nickel 18.4. It is more expensive than any metal in use and less easily worked, facts that add considerably to the cost of articles made of it. It is about the same in weight as solid silver and has the same bell-like ring. In fact a finely finished piece of electro-plated nickel ware cannot be

distinguished from solid silver even by an expert. It is almost exclusively employed in the manufacture of small pieces subject to extraordinary wear, such as spoons, forks, etc., and in a lesser degree for all other articles in electro-plate. The cost of the latter, however, precludes its use except among the wealthy classes, and a metal more ductile and of less expensive ingredients was demanded by the popular purse. Pewter had been used by the Germans for many years in the manufacture of articles for the table. It was generally composed of four parts of tin to one of lead, and was extremely soft. The British improved upon this by substituting for the lead alloy various proportions of copper and antimony, calling the new metal "Britannia." Britannia can be electro-plated, and is still extensively used by many manufacturers, but although far superior to pewter it is classed as a soft metal and unsuitable for articles demanding firmness and durability. It was to overcome this difficulty that the composition now so widely and favorably known as "white metal" was devised. The manufacture of this metal is one of the secrets of the workshop, but as the poorest pewter of unprincipled makers may be called "white metal," so between even the largest and most reputable manufacturers there are grades of quality according to their different formulas. The composition of the essential ingredient is known only to the metal mixer, who calls it "hardening metal." This latter, and its proportions to the other metals used, determines the value of the entire compound. Properly mixed white metal is a hard, firm, resonant metal of considerable tenacity, and is capable of receiving a very highly polished and smooth surface, properties very important in articles to be electro-plated. Its durability is unquestioned, having been for years in constant use. Reliability in the metallic base of electro-plated ware is of great importance to the consumer, since inferior metal presents the same appearance when covered with silver as the most valuable. There is, therefore, absolutely no other guarantee against fraud than the reputation of the manufacturers, who (in the case of old and established houses) have too much capital at stake to debase their products, even if ordinary business integrity proved insufficient.

Opening here the history of electricity as applied to electro-gold and silver plate, and without discussing too exhaustively a subject of such magnitude, we find that frictional electricity was well known 600, B.C., having been developed by Thales of Miletus in rubbed amber, from which substance it takes its name (*ἤλεκτρον*). Observing merely the effects, Thales believed that amber possessed a soul, which, being excited by friction, left the body and attracted light bodies to it. The peculiar electric shocks of the torpedo fish were also experienced by the ancients, but without definite and correct knowledge of the cause. Beyond these simple observations of the phenomena, no progress was made in the science until Dr. Gilbert, of Colchester (A.D., 1540-1603), began the series of experiments that won for him the title of the "Father of Electricity."

From this point sprang numerous investigators, including Robert Boyle (1627-91), Otto Von Guericke (1602-86), Sir Isaac Newton (1643-1727), Stephen Gray (1696-1736), M. Dufay (1699-1739), Benjamin Franklin (1706-90), and Sir William Watson (1715-1807). In 1745 the "Leyden phial" or "jar" was invented, and seven years later Franklin performed his celebrated experiment with lightning by means of a kite. At this date scientists could not only produce electricity, but also, by using the Leyden jar, partially confine it. Friction, however, was the only known method of generating the fluid until the accidental discovery of Galvani in 1786. The story runs that he had skinned some frogs to make broth for his wife, who was in poor health. The leg of one of these being touched by a scalpel, which had lain near an electrical machine, was thrown into violent convulsions; which, the wife observing, reported to her husband. Following up this discovery by experiment, Galvani found also that the suspension of certain frogs' legs upon an iron railing by copper hooks caused a twitching in the muscles. From these phenomena he deduced the theory of "Animal Electricity." Being a physician and physiologist, it was perhaps natural that he should

make everything bend to the line of his profession, but Volta (a philosopher) attacked his theories, and a brisk argumentative war was inaugurated, ending only with the death of Galvani in 1798. Soon after (1800) Volta proved his position by the invention of the "Voltaic pile," giving rise to a new branch of electrical science, called, in honor of the first experimenter, "Galvanism." Three years later Brugnatelli, a pupil of Volta, discovered that when a galvanic current passed through a metallic solution decomposition or disintegration took place; the metal attaching itself to the negative pole and the acid or alkali similarly attaching itself to the positive pole. "I have lately" (Brugnatelli in a letter to Van Mons) "gilt in a complete manner two large silver medals, by bringing them into communication by means of a steel wire, with the negative pole of a voltaic pile, and keeping them one after the other immersed in ammoniuret of gold newly made and well saturated." This is the first instance in which any metal was ever reduced by galvanism. Numerous experiments followed. In 1836 a great step was taken by the invention of Daniell's "constant" battery. By the year 1868, however, it was almost entirely abandoned, owing to the trouble it involved to keep it in good working order. It was while detailing some experiments made with this battery that De la Rue made the following incidental observation: "The copper plate is also covered with a coating of metallic copper, which is continually being deposited; and so perfect is the sheet of copper thus formed that, being stripped off, it has the counterpart of every scratch of the plate on which it is deposited." In 1838 Prof. Jacobi, of St. Petersburg, announced his ability to produce a *relievo* in copper of the finest lines, by means of galvanism, while in the following year Mr. C. J. Jordan, an English printer, perfected the process of electrotyping. The new discovery was christened with two names: by Mr. Alfred Smee (the inventor of Smee's battery) it was called "Electro-metalurgy," and by Prof. Jacobi and the French "Galvano-plastic," both names being appropriate although the first is perhaps preferable. While still in embryo, as far as direct and practical usefulness was concerned, its historical progress was signalized by a sort of electro-mania or "craze," and it became a fashionable amusement to copy coins, medals, seals, etc., by the new process, many ladies, even, having the apparatus in their homes and becoming quite skilful in its use. It was left, however, to a manufacturer in Birmingham (England) to combine the different discoveries and experimental results of forty years and make a practical use of them in the production of household articles coated with the noble metals. Thus was born (1840) a new and important branch of mechanical art—the manufacture of electro-gold and silver plate.

In electro-plating the silver should be as pure as possible. It is usually purchased by the larger manufacturers in bars, assayed by the government, and of a fineness of .999 or .999½. For over eighteen years the writer does not remember but two instances when he has been able to procure silver absolutely without alloy. Such purity is evidently very difficult to obtain by any known process of assaying. The bars being first converted into flat sheets by powerful rolls and cut to a convenient size, are, by means of electricity, first disintegrated and afterwards deposited upon the metal base. The liquid which holds in suspension the disintegrated silver is called a silver solution (Faraday called it "the *electrolyte*") and is composed of one part cyanide of silver, two or three parts cyanide of potassium dissolved in about 150 gallons of water. This solution, first used by John Wright, of England, has been found infinitely superior to any other, as being an alkali the tendency of its action creates less opposing electro-motive force. It is held in wooden vats lined with asphaltum, over the two ends of which run the positive wires of the battery; the negative wires running across the center. The pure silver hanging suspended in the solution from the positive wire, and the article to be plated being similarly suspended from the negative wire, the circuit is established and the plating begins. The chemical reaction of the process is not yet perfectly understood, but it seems clear that the double salts serve simply to hold the silver in

solution, and that the disintegration and deposition is effected by the water only. Water alone is not considered a good conductor of electricity, but it becomes so in combination with the salts. The two gases which form water (H., O.), are decomposed by the electric current; the hydrogen passing to the negative electrode (or article to be plated), while the oxygen is attracted to the positive electrode (or pure silver), and creates the oxide of silver. This oxide coming in contact with the negative electrode meets there the hydrogen. In the union of the oxygen and hydrogen to again form water the silver is thrown down upon the article in a crystalline deposit. The metallic strength of the solution is thus constantly maintained. "The fluid between the electrodes, whilst decomposition is taking place, apparently undergoes no change; that is, the effects of the decomposition are only manifested at the poles; thus if sulphate of copper be electrolyzed, sulphuric acid passes one way, oxide of copper another; yet neither acid nor oxide can be found in any part intervening." (Smee).

(To be Continued.)

Watch Repairing.

BY HERMAN SIEVERT.

III.

THE CLICK-WORK must never work hard and audible; too strong a spring produces a useless and injurious friction. But while with the click-work with simple spring a possible tearing off, in case of a blow, must always be anticipated, the spring of the other kind need only be very feeble. Since the sharp corner of the cone produces an important friction, round it off in the manner indicated; the click will move greatly easier thereby.

Of course, the correct shape of the teeth is presupposed by both click-works, the operating surfaces of which, as is known, coincides with the radius of the wheel. Again, the parts of spring and cone seizing into the wheel must be filed exactly vertical to the wheel's plane, so that click-spring or cone be not pushed aside by the effect of the oblique face. Both are to be thoroughly fastened, and the cone screw, especially, must be in such a condition that it can be tightened securely, without pinching the cone. A carelessness in this respect is apt to entail the loss of the cone and other greater damages. In common with pendulums, the cone must have a little shake both backward and forward, to avoid its injurious hanging to the tooth points.

All parts of the click-work must be well hardened—the operating parts of the click-spring and cone are to be annealed brown, all the other parts blue. Whenever you meet with soft springs or cones, when repairing a watch, never evade the very small trouble of hardening them. These parts wear off very soon, if soft, and are then generally useless, and betray the botch. In order to spare the faces during tempering, coat them with soap; the polishing afterward does not consume so much time. If you cannot spend much time over polishing, an effective touch with emery will suffice; a well-hardened click-work ground with emery is by all odds preferable to a handsomely polished one, if soft.

THE MAINSPRING.

To enable the mainspring to fold into the requisite number of coils, the spring core must not be too thick. If made too thin, however, it might favor the breaking of the spring. Experience has established that the thickness of a core must be one-third of the inner barrel diameter. The spring of a correct length and thickness, when unwound, occupies with 14 coils at each side of the inner barrel wall one-sixth of the above diameter. Under these circumstances, the spring will admit about $5\frac{1}{2}$ turns, until fully wound. The stop-work permits four turns, and is mounted in such a manner that it prevents the spring against undue winding or running down by about the same quantity. When choosing a new spring, do not take pattern by the old one, because this may not have been a suitable one. Good springs are wound thus that their diameters within

the wire ring is equal to the inner diameter of the corresponding barrel. First, however, mount the spring for trial, and examine if it occupies its space with 14 coils. Should it contain more, and the space is occupied correspondingly, the spring will suit, after having been shortened. If, however, the space is too full with this number of coils, it then will be too short. The hole in the spring must never be round, but form a long rectangular triangle. A round hole weakens the spring too much on one place, and will easily tear out for this reason.

The spring has to move free within the barrel; it must neither be too broad, nor the spring hook on the core draw it to one side. Therefore file the hook very small, and toward the center; beside this, it is not to be higher than the thickness of one spring blade, so as not to occasion the bursting of the spring. The outer hook also should not be too large; it is best screwed from the outside through the barrel wall in the following manner: Drill a medium-sized hole obliquely through the barrel wall, opposed to the power exertion of the spring. After the thread has been cut in, and the sharp burr inside removed with a sharp graver, screw in a brass pin provided with the same thread, and while in the hand vise mark its position; at a length about equal to its thickness cut off the wire from within with the nippers, and screw it out again. In order, now, to form the hook, you have nothing else to do than to file the wire beveled at the marked place in the hand vise. Next tighten the hook finally and separate it also from the outside. Now take the outer end between the tweezers and form the point produced by the filing bevel, into a hook. A hook produced in this manner will be very strong, and occupy but little place. If the screw thread was good, it is not possible that the spring can press out the hook. Carefully file the outer end smooth with the barrel wall, without injuring its teeth, however.

If a spring has bursted in a watch, never omit to examine whether a tooth in the barrel wheel has not been injured by the recoil of the spring. It happens sometimes even that a tooth breaks.

THE CENTER AND FOURTH WHEELS.

The polishing of the pivots of these two wheels is less difficult, since we possess an excellent auxiliary in the Jacot lathe. I will simply add that a follower roller is of much use for this instrument, whereby the time consumed in fastening of rollers upon wheel arbors is saved. If you propel the wheel by means of the drill bow, in the polishing of pivots, be sure to make long strokes, so as not to wear the pivot more upon one than upon the other side. The polishing with the fly wheel has the advantage beside the constant motion, that the cord does not slip as easily from the pulley as by the drill bow.

The pivots must not be too thick, but not by any means too thin. Thin pivots, together with the holes, are subject to a rapid wear, caused by the pressure being concentrated upon too small a face.

Owing to the small weight of the wheels in proportion to the moving power, the friction of shoulders can barely be taken into account and they may therefore be chamfered but little. They must run true round, however, since in rounding, not the pivots, but the shoulders, decide the becoming round of the wheel. But it is decidedly wrong to turn the shoulders or the bevels very small, almost down to the pivot, because these small shoulders retain the oil but badly. Proportions are decidedly unfavorable in this regard, where the pinion reaches nearly to the pivot. A right sharp cut is to be turned in every time.

The bushing of the holes must be done with much care. With proportions so small, the slightest mistake amounts to much, and since every wheel must also be mounted straight, at once two depths are ruined with one single awkwardly inserted bushing.

For this reason, as well as for the sake of facilitating work, I would recommend to buy bushings at some utensil store, without thread. They are fastened exactly in the same way as the turned bushing, only that by deep countersinkings, round punches must be used as underlay. If this is too inconvenient for you, first hammer in the bushing so far that it just protrudes into the countersink, then reverse

the plate and rivet with the round punch. If you did not omit preparing somewhat with the pointed chamferer on the outside, the bushing cannot be pressed out again, if also the countersink is made clean and smooth. Such a bushing fits at least as well as a screw bushing, and, what is of more importance, a hole cannot be set out of place even by carelessness. It is well to shorten an unduly long bushing previously, so that the hole is not closed by riveting.

A small bushing must never protrude into the countersink; a protruding one is a hindrance to the oil in the sink, since it cannot enter into the hole. Again, a protruding bushing forms a corner, from which the dirt cannot be removed when cleaning the watch. If a very deep sink requires a long bushing, it must be so large that it can form a small sink for itself.

The gilding in the sinks must be spared as much as possible; the large oil funnels are a badly arranged ornamentation, since they are simply dirt catchers, and assist in contaminating the oil.

I have already remarked that the pivot holes in the lower plates are not displaced without sufficient cause, since errors are easily created thereby. A wheel occupying an untrue sink, or a hand standing to one side of the seconds dial, do not by any means appear well. Therefore bush first the two holes in the plate. Next close the upper holes either by a small or a large screw bushing, according to the nature of the sink, and upright it in the uprighting tool. The examination whether a wheel stands straight or not consumes nearly as much time as the uprighting, and the latter is always best with the upper holes in case they are to be bushed. I call your attention to the fact that the same rule holds good for the inserting in the uprighting tool as the centering, by means of the centering point in the universal lathe; if the lower oil sink is crooked, and thereby the corner of the hole irregularly chamfered, the uprighting will also not result well. Furthermore, pay attention to the direction of the drill in drilling the upper hole; I would recommend not to drill horizontally, but to lay the plate, together with the bridge, upon the bench, and permit the point of the drill to run in a turning tool point or other, held with the left hand. You may then observe better the insertion of the drill into the hole marked by the uprighting tool.

Pivot drills are made from already hardened steel, left soft enough to be filed. The steel for very small drills is finally made still thinner with the oil pin. The spoon is next shaped to it, and ground in the customary manner. These drills are not suitable for drilling steel, on account of their low temper.

After the holes have been opened to the right size, so that the wheel moving therein has sufficient shake toward all sides, break the sharp edges upon both sides with a pointed chamferer. A sharp-cornered hole does not permit the pegwood to enter clearly, and scratches off chips, which contaminate the hole. Next clean the holes from all dirt and metal chips, and mount the wheels singly. You must expend much care to ascertain whether a wheel runs actually free and with sufficient end shake in its holes; a pinching, no matter how small, always causes the standing still of the watch, even if perhaps in the future.

The fourth wheel must not be too heavy. An unduly thick wheel is to be filed thinner. Nor permit the wheel to run too close to the bottom; even if it does not exactly scrape, still it is apt to cause the standing of the watch, as soon as a little dirt gathers at the bottom, or it introduces the dust lying on the bottom into the scape pinion. But if not sufficient space is present, you must make the sink for the wheel deeper upon the universal lathe. While the latter plan is also used to advantage to turn the center wheel bridge thinner, in case of necessity, it is better to file the two bridges for the center and fourth wheel, so as to obtain shake for the wheels, but only if their strength permits it. A neat workman next removes the strokes of the file by a suitable emery-paper file. The best way is to hold the bridge, by this work, with the gilded side upon the index finger of the left hand. But this finger must be very clean, since the least trace of oil attacks the gilding. Even the softest paper, if the gilded surface rubs upon it, has a grinding effect. Of course, the edges of

the bridge must not come too near the wheels; wherefore file off all corners and edges that might become dangerous.

It shows a careless workman if burr is hammered on the lower side of the bridge, in order to place it higher or lower. Not alone that the wheel thereby is placed obliquely again, but the bridge also assumes a bad appearance, and loses in firmness. If a pinion is decidedly too long, it must be corrected by the turning back of the pivot. A forcible removing, however, of the bridge, in order to place wheels straight or correct depths, will be attempted by no good workman, as long as the error can be corrected from another side. Of course, the oblique position of wheels in eight-jewel watches, is an awkward question, and cheap and badly constructed eight-jewel watches should never be purchased.

THE CYLINDER ESCAPE WHEEL,

On account of the shortness of its arbor, is generally inclined to stand oblique, and this must be corrected by the displacement of the bridge. This is here easier possible and permissible, since it only demands a trifle, and the screwhead is not sunk in. With a pointed chamferer (do not enlarge the holes by means of a reamer) create a little shake for the bending of the foot pins, and in case that the wheel must be removed in the direction of the bridge, also provide a little space for the screw, by filing out the hole in the bridge. After having bent the foot pins in the corresponding direction, first tighten the bridge without the wheel by screwing, so as not to break the wheel pivots by this first forcing in of the foot pins. After this ascertain, by placing in the wheel, whether it stands straight, or in what manner it is best to be corrected. It is not difficult, with a little practice, to hit the true means. The end shake of the wheel may be corrected by bending the thin bridge.

An infringement, or a close approach of the wheel, even, to the bottom of the bridge is to be guarded against very carefully, by the small power of the wheel. Especially the cut in the bridge for the passage of the wheel teeth is a dangerous place. If the space between wheel and bridge is too small, there is danger that the wheel teeth establish connection with the bridge, and hang, occasioned by the oil or dirt. If the possibility of such an occurrence is not thoroughly excluded, it is well to make the cut deeper. This is executed best upon the universal tool, by lacking the bridge upon a turned face. You may also remove some of it with a square file. In this case, however, lay the wheel upon the bridge, so as to see whether the filed cut is sufficiently broad, since this breadth, of course, must be greater than in the case of a turned-in cut.

The shoulders of the pinion arbor must be made very small, because since the glueing of a broad shoulder, due to thickened oil, would be an important hindrance for the trifling power of the wheel. It is also very necessary here to keep the oil away, which is best effected by sufficient grooves in the pinion arbor, and even if the oil running into the pinion is no special hindrance for the depthing, still, the dust mixing with such oil will limit the shake of the teeth.

THE CORRECTION OF THE DEPTHS.

The first requirements complied with, that all wheels move free and steady, the correction of the depths is undertaken next. The examination of the depths in the watch gives better results than in the depthing tool, even if the depthing be not visible. The most trifling mistake in the transport of the depthing distance of the holes upon the tool, by the smallness of the parts, produces frequently grave results, so that a depthing which was satisfactory in the tool, is afterward too deep or too shallow in the watch. In order to examine a depthing carefully, mount only the requisite two wheels. If you slightly arrest the pinion by the pressing down of the bridge or holding a pegwood on the pinion arbor, push the engaging wheel along with another pegwood. You will be able to feel every defect of the depthing by a delicate touch; if still uncertain, use other means of rendering the depthing visible, by the center wheel depthing, for instance, bevel the bridge from below; this, however, is to be done in so gentle a manner that it cannot be seen from above. Small holes are drilled into movements which, instead of bridges, have an upper plate.

If a depthing under examination passes through smoothly and without jerking, and has sufficient shake of teeth, it can be called good. But if not sufficient shake is present, if the tooth is badly shaped, or, worse yet, if the wheel is out of round, the rounding and cutting machine or Ingold fraizes must be made use of. Always seek hereby to give the tooth an approachingly correct shape; only a pinion with thick leaves, which you are forced to retain, can compel you to make the wheel tooth somewhat narrower than the breadth of the intervals between two. Too thin a tooth always produces a greater friction in depthing, and an unequal transmission of power. Especial care is required for the depthing in the escape pinion. The small number of its teeth renders this depthing a difficult one, still, a greater number of leaves cannot be chosen, in consideration of the thereby rapidly decreasing shake. This must not be too scant, since the ever collecting dirt in a watch must be duly considered, which causes a stoppage, especially of the fourth wheel pinion. Again, the striking of the tooth points against the bottom of the pinion is to be feared and the defect looked after, since it is often the cause of the standing still of the watch. In an ordinarily constructed watch, all the depthings are kept asunder by the moving power, and only the fourth wheel is by it crowded nearer to the scape pinion. The best side shake of the fourth pivot can effect that the depthing may pass through apparently correct, when examining it, and still cause the watch to stop afterward. The striking on the bottom of the tooth points always presupposes thin wheel teeth, or a pinion with thick cone. This striking cannot occur if both parts are good, and sufficient tooth shake is present. A bad scape pinion had better be replaced, since it becomes too easily a constant source of annoyance.

It is often found, when examining the depthings, that one or the other is too shallow; in such a case try to stretch the wheel somewhat. If done in an intelligent manner, no objections whatever can be raised against the work; only it must not lead to inequalities of the tothing. A real practical utensil for this purpose is represented in fig. 20. A round anvil, provided with a shoulder for fastening in a vise, is perforated throughout its length, and united by a pivot with an equally perforated punch of the same diameter. The pivot remains firm in the anvil, while the punch is loose upon it. To prevent dirt from falling in when hammering upon it, the hole in the punch is closed by a tampion. The wheel to be enlarged is held with the left hand as far as the pinion between punch and anvil, pinion downward, so that the punch does not press upon it. If both anvil and punch are well polished, and all filth is carefully removed, the polish of the wheel will suffer but little. A uniformly thick wheel, of course, is required, so that all parts are stretched alike, and it must be equipoised by a rounding tool after stretching.

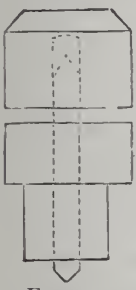

FIG. 20.

If stretching is not successful, or if a wheel was previously already useless, the mounting of a new one is not whatever difficult. After having taken down the old wheel, turn the shoulder in a workmanlike manner, and also make a good underturning. By the use of the safety roller, this can be done without anticipating any danger to the fourth pivot, only pay attention that it is not bent. So as not to open the hole in the wheel too much, fit the pinion shoulder into a hole of the riveting tool, or other set of well-graduated holes, gauge the width of hole by inserting the chamferer. The wheel must fit firmly upon the pinion shoulder, and be of sufficient thickness that the points created by the underturning barely protrude. A few slight taps upon the appropriate hole punch will finally fasten the wheel.

PLACING THE DEPTHING INTO THE TOOL.

The workman who has no rounding at his disposal, will generally be compelled to leave the wheel teeth in their actual condition. Of course, the correction of the depthings must in such a case be done by the removal of the holes. The depthings must be corrected first, and, if wrong, the holes are to be closed by screw bushing. The

fourth wheel depthing is first to be corrected in the tool, and an arc struck therewith from the pivot hole of the scape wheel in the plate. As nearly to the center of the scape wheel as possible, but exactly upon the arc, the hole is marked and drilled, and the hole in the bridge is uprighted thereby. It is now to be ascertained first whether the depthing has become correct. The center wheel depthing is then set, looked after in the same manner, and the hole drilled exactly at the point of intersection of the two arcs.

It is inadmissible, especially by watches with seconds hand, to correct both the center wheel and fourth wheel depthing at the same time, as the fourth wheel would be pressed too much out of its place.

(Concluded.)

The Jewelers' League.

THE JEWELERS' CIRCULAR is the *exclusive* official paper of the Jewelers' League, and has been selected for the publication of all matters of interest pertaining thereto. Letters or inquiries pertinent to its business or purposes, and which might interest the trade or inquirers, will herein be answered. Address *Jewelers' League, Box 3,444, P. O., New York*, or the office of THE CIRCULAR.

At the regular monthly meeting of the Executive Committee, held on Friday, March 2d, at the office of the League, No. 61 Nassau street, the following named applicants were admitted to membership:

John W. Block, Samuel Joel, Maurice Klaber, Alexander J. Comrie, Joseph Delphin, Jr., Nathan Glauber, Alfred T. Weller, David Wolff, Edward B. Eaton, Wm. W. Hayden, Irving A. Lewis, Frederick Walker, New York City; James F. Budlong, Providence, R. I.; Peter Blackmer, Boston, Mass.; Otto Driesner, Hiram Pickering, North Attleboro, Mass.; Chas. J. Chevalier, Max Matthias, George Marchal, Brooklyn, N. Y.; Chas. F. Marsh, Rochester, N. Y.; James Dangerfield, Fredonia, N. Y.; Chas. F. Tinckler, Frederick A. Schuetz, Newark, N. J.; Henry Stone, Irvington, N. J.; Louis Atkinson, Francis Glückert, Philadelphia, Pa.; Christian A. Sievers, York, Pa.; Ross L. King, Lucien C. Bullard, Bradford, Pa.; Harry B. Cubbison, New Castle, Pa.; Henry Erbsmehl, Laurel, Del.; Chas. F. W. Volckman, Baltimore, Md.; Girolamo Desio, Washington, D. C.; J. C. Freeman, Jr., Atlanta, Ga.; Emil Gluck, Tuscaloosa, Ala.; Richard D. Kirby, Adolph Freud, Phillip Mammoser, Robt. S. Hubbell, Chicago, Ill.; Max Bauman, Henry Wild, Alfred H. Schweickhardt, Otto W. Eckhold, St. Louis, Mo.; Robert Tetly, Farmington, Mo.; Alfred T. Selkirk, Charlotte, Mich.; James H. Wheeler, Tremont, Neb.; Edgar James, Columbia, Tenn.; Theodore H. Kortum, Shreveport, La.; William W. Woodcock, San Antonio, Texas.

Forty-nine in number accepted, and making the membership at this time reach the surprising figure 2,462; five changes of beneficiary were granted, and ten applications were referred for further consideration.

Treasurer Sexton announced the balances on hand: General fund, \$3,075.97; Benefit fund, \$4,575.20.

Francis Glückert, of Philadelphia, is the possessor of certificate of membership numbered 2,500.

The Executive Committee could well be assisted in their arduous duties in discriminating between those whose applications should be accepted and those who should be rejected, if the members who recommend applicants would digest the following remarks of the President of the N. W. Traveling Men's Association, at their annual meeting in Chicago, December 27, 1882. The Executive Committee of the League are not, perhaps, so reliant upon the one feature of the application for membership in the League as is indicated by President Cutter's remark upon the dependence placed on the recommendations, still the suggestions are of a practical character, and will be appreciated by the members. Among other points he calls attention to the following:

"To the increasing necessity that every member should thoroughly

scrutinize the names presented to him for his recommendation for membership in our Association. Your Directors depend largely upon these endorsements when the application comes before them for acceptance or rejection. It has come to my notice during the past year that there was not care enough taken on this point. If, through a desire to help a friend, or if it may be through carelessness, you recommend a person who has some disease of body or habit, and the examining physician is not sharp enough to detect it in his examination, and upon your recommendation the Directors accept the applicant, and in a short time he dies of liver disease, consumption, or the effects of whisky, then you inflict upon the living and temperate members a wrong which should be made punishable by expulsion from the Association."

The Secretary reports no deaths in the League, and expresses the opinion that under these circumstances the members can afford to be as patient as he is. Daily inquiries are received at the League office as to the time of making another assessment. One member writes: "Not having received any notice of an assessment in our League, I made up my mind that I must have been skipped, or our members must be a healthy set of men, as I get my notice regular from other institutions of the kind once a month."

An excellent plan would be to save up in anticipation of assessments to come.

Æsthetic Shams.

THE PRESENT will be known as an age of collectors. The taste for bric-à-brac, antiques, and curiosities, formerly confined to princes and a few connoisseurs here and there, is now very general. In every civilized country, everything that is rare or difficult to procure has its admirers, who make it their business and pleasure to collect specimens, to preserve them and show them to their friends. The fashion is a useful one; for if nothing is more sad than the loss for want of care of a beautiful piece of work, on which the labor and thought of some man above the common have been expended, it follows that he who charges himself with the preservation of such objects is a public benefactor. This is especially true in view of the extension of the modern system of manufacturing by machinery. If it goes on, pretty soon no more hand-made work of good quality will be produced. In many cases it is already incumbent upon us to preserve what we have, as no more of the same kind can be obtained; either the old processes are forgotten or machine-made wares have driven the hand-made out of existence; or a falling off in taste or in skill, very often consequent on mere familiarity with machine-made work in other kinds, has taken place. Occasionally too, an increased facility in working has brought about a debasement of taste in a manufacture. Thus the earlier potteries of China and Corea have more artistic value than the clever productions of modern Japanese workers; and so, too, the somewhat coarse Venetian woodcuts of the seventeenth century are finer as works of art than the best fac-simile engraving of to-day. It is well, therefore, to follow the advice of the apostle, and "hold fast to that which is good" in regard to objects of art as well as in other things. The world cannot afford to lose any work into which a man has put his honest endeavor to do well and his desire to produce something beautiful.

But, unhappily, the wish to possess rarities of this sort has created an industry which is prospering and growing greater day by day: that of the fabrication of false antiques and of copies which are put forward as originals. Thus a man may pay five hundred dollars for what he supposes is an enamel of the sixteenth or seventeenth century, and find afterward that it was made but a year or two ago, and cost the enterprising manufacturer five dollars. Or he may think that a coin bought from a dealer was in circulation in the time of the Cæsars, while it may have been made in an electrotypist's bath here in New York. The growth of this trade is likely to interfere seriously with real industrial progress, as well by drawing the most capable workmen of our time away from their legitimate employ-

ments as by creating a distrust of the reality of everything that pretends to have either archæological or artistic value.

Paris is the headquarters of this nefarious traffic; it is the chief mart for counterfeits, electrotypes, veneers; for things patched up, retouched, and stuck together. Statues, furniture, faience, offensive and defensive arms, vases of Sèvres, etchings of Rembrandt, old English silverware, Tanagra statuettes, even modern work by celebrated masters, such as Delacroix and Corot, are imitated sometimes with consummate skill. It is in Paris that they invented "the dust of ages," which is blown with a small bellows into worm holes bored with an auger. It is in Paris that they make the most deceitful imitations of old Eastern rugs, of Gothic wood carvings, of Venetian stamped leather.

But the Parisians have by no means a monopoly of the business. English manufacturers turn out vases of Sèvres rose, and produce the old *pate tendre* by the wholesale. Egyptian antiquities are manufactured by the Bedouins, and scraps of old earthenware from the Campagna of Rome are painted in the Eternal City with figures in the manner of the ancients, burnt anew, and sold as the veritable work of Græco-Roman artists.

In this country it is only of late years that there has been much encouragement for such an industry; but already its foundations have been laid here. In the bric-à-brac shops it is not unusual to come across some old piece of furniture with modern carvings in wood, or perhaps electrotype reproductions of old metal work fastened on. There are electrotypers who can handle their batteries and baths so skilfully that they can copy almost any object in metal with such perfection that all ordinary tests will fail in detecting the fraud. Not only the form and color of the object, but its specific gravity, its density, its hardness, the ring which it gives when struck, can all be faithfully copied. Luckily, those men are few, and their services are in demand for more honorable work.

The greater number of artistic frauds that are practised in this country are not difficult of detection. Their object generally is to pass machine work off for hand work at a high figure. Thus machine-made embroideries, copied from good Eastern designs, are sometimes taken up with a little hand work, are frayed and carefully darned in places, or are purposely soiled to give them a look of age. Japanese antiques are likewise manufactured here on a considerable scale. Small ornamental pieces of metal work or carvings in wood or ivory, lacquer plaques, and so forth, are imported from Japan in quantities, and fastened on to cabinets made in this country of common woods, the whole being then sold as Japanese. Even respectable dealers keep these wares, but acknowledge their true character when questioned. In Japan itself the more famous old wares of the country are regularly counterfeited for the American market. Thus the cream-colored pottery commonly sold under the name of Satsuma ware is all false, and there is no famous ware of any part of Japan that is not counterfeited in some other province. Of late, too, certain dealers have got into the habit of bringing American or European materials into Japan, there to be worked up into the articles that the natives best know how to fabricate. Those are then imported and find sale here. Tobacco pouches, medicine cases, knife sheaths, will often be found of old Dutch or Cordovan stamped leather, too rotten, perhaps, for other use, ornamented with gilt and silvered figures in Japan, and attached to some real Japanese article.

On the other hand, articles of undoubted authenticity are not uncommonly broken up and destroyed to enrich some modern piece of work with their ruins. The tarnished silver galloon ripped from old Spanish or Italian vestments has added to the splendors of the hangings that are displayed by more than one of our millionaires. Daghestan and Persian rugs, which in another generation or two would be priceless, are ruthlessly cut up for chair backs and sofa covers. This is a result of the mania for old things which genuine collectors are the first to condemn.

Perhaps, after all, more harm is wrought by confessed imitations than by fraudulent ones, which to be successful must be pretty good

The wretched machine work in faded colors in imitation of antique embroidery which is imported from France and Germany is more exasperating than the American-Cretan and American-Persian work we have been describing. There are imitations of stamped leather which have none of the qualities that make the real thing valuable. There has even just begun to be made an imitation of stained glass in celluloid paper, which is more abominable, if possible, than the worst that our unartistic glass stainers can produce.

People who buy such work have, of course, only themselves to blame; but in many cases it is difficult for one not acquainted with the facts to distinguish the genuine from the imitative work, if the dealer does not take the trouble to point out the difference. In the matter of rehabilitated antiques, it is very hard to draw the line at which the renovating process should stop. It would perhaps be safe to lay down the rule that only so much should be done to a piece of furniture, or the like, as is necessary to keep it in a useful condition, and that the patches or the new portions should show distinctly. Nothing should be added as ornament, nor should any attempt be made at "artistic restoration." It is very seldom allowable to make over old material into entirely new shapes, and, generally speaking, the best thing to do with old work past usefulness is to preserve it, for whatever artistic qualities it may have, exactly in the state in which it is.

In regard to the counterfeits prepared in other countries and sold here in large number, buyers cannot be too wary. Even dealers who have all their lives made a specialty of some one thing are sometimes taken in. Of course, when an article is so nearly like the original as this, it is also of nearly equal artistic value. But the archaeological value of an object is often much more than its artistic value. The best rule for those who are not experts is to buy only what is beautiful, and only from dealers of reputation. They will then run as little risk as possible, and even if they be mistaken as to the authenticity of their purchase, they will be consoled by its intrinsic merit. A large number of counterfeits are, however, known and classified. There are marks by which experts may tell the real old Sèvres ware from the imitations of the last century; the presence of certain metallic colors and the use of certain processes of burnishing the gilding are often sufficient to point out the false ware. But manufacturers of to-day know these marks as well as any connoisseur, and against them all such signs would be useless. In the case of a Japanese product, it is next to impossible, even when the piece is marked and no fraud is intended, to place it either as to age or locality of manufacture. The same man may change his trade mark three or four times in his life; each time he may sell or give his old trade name to whom he pleases; and though living in one province, he may use the name of another as his trade mark. Then, in Japan, processes of manufacture never become so settled as they are with us, and this adds to the difficulty of classifying the products. Thus Kaga ware may be made in Kioto, and Banko ware, which is supposed to be made by pinching the clay between the finger and thumb, may be simulated by work thrown on the wheel. But if a man buys a beautiful piece of work, and pays no more for it than he can afford, he need not care very much in what out-of-the-way Japanese village it was made.

The best plan to prevent artistic counterfeiting in the future would undoubtedly be to refuse to buy manifest imitations of any sort, and to encourage the best artists to produce original works.

Removals.

On or about April 1st.

Noah Mitchell, from 696 Broadway to 52 Maiden Lane; Leroy W. Fairchild, from 1 to 18 John street; Traitel Bros., from 170 Broadway to 40 Maiden Lane; A. Bantle, from 79 Nassau street to 89 Nassau street; Baker & Co., from 104 to 408 N. J. R. R. Ave., Newark, N. J.

On or about May 1st.

Waterbury Watch Co., from 4 to 52 Maiden Lane; Carter, Sloan & Co., from 694 Broadway to 15 Maiden Lane; Mabie, Todd & Co., from 180 Broadway to Bryant Building; Henry Carter, from 176 Broadway to Bryant Building; Courversier, Wilcox & Co., from 12 Maiden Lane to Bryant Building; Charles Glatz, from 10 Maiden Lane to Bryant Building; Dueber Watch Case Co., from 16 Maiden Lane to Bryant Building; Ketcham & McDougal, from 4 Liberty Place to Bryant Building; Isaac A. Alling & Co., open New York office in Bryant Building; Krementz & Co., from 192 Broadway to 182 Broadway; Rest Fenner Smith & Co., from 4 Great Jones street to 710 Broadway; Lincoln & Bacon Manufacturing Co., from 15 Maiden Lane to 12 Maiden Lane.

Celebrated Horologists.

JEAN-ANTOINE LÉPINE.

The following biography of this celebrated watchmaker, of whose life little is still known, is taken from the *Journal Suisse d'Horlogerie*, and was written by a descendant, the vicar of the bishopric Gap, in France.

Lépine was born November 18, 1720, in Challex,* District Gex, of the Department Ain, on the south-western slope of the Jura. From early youth forward, he evinced a great predilection for all work pertaining to mechanics, and under the tuition of a skilful master, he soon developed capacities of a high order.

At the age of 24 years, he went to Paris, and soon attracted notice by his skilful work. He engaged with M. Caron, the father of the well-known Caron de Beaumarchais, who admitted him as partner to the business, and whose daughter he married. This new position offered rare opportunities to Lépine to institute experiments which he had conceived for improving watches; those provided with his improvements have retained his name to the present day, and caused at that time a complete revolution in horology.

He dispensed with the fuzee, around which the chain wraps when the watch is wound, and constructed the toothed barrel, whereby this could render the functions of the expelled part. As soon as he noticed that through the lack of the fuzee, which had served for regulating the power of the spring, his watch gained very fast when wound, and lost when the power of the spring was almost expended, he introduced the whip-form spring, which was weaker at its outer end than at the barrel core, and by this improvement, together with the comma escapement, invented by him, he obtained a perfectly regular rate, and this improvement permitted him to construct watches so thin that they could be mounted in finger rings.

The fame of Lépine spread throughout all the parts of the world, by his watches. He had the honor of presenting to Louis XV. an astronomical clock, composed by himself, and provided with equation and perpetual almanac, for which attention he was nominated to the position of Court watchmaker. He engaged in the construction of watches with free springing seconds; which endeavor, however, have, up to date, met with no decided success, for the reason that the balance vibrations are far too slow, and watches deviate when worn. He sought to incorporate his ideas through various combinations, of which the straight-line or so-called ratchet pinion appears to be the most ingenious.

This latter invention gave pinions with no drop, and consequently a very trifling loss of power. This method, to the sorrow of all good workmen, has been abandoned.

Lépine also constructed very complicated pendulum clocks, with date, position of moon, etc., and to be wound only once a year. It can be seen from his business books that he furnished such clocks

* This community possessed many watchmaker shops, and still furnishes to-day a number of valuable workmen to the Geneva establishments. J. J. Rousseau was also an apprentice here. It is told that after having been an apprentice to his father, living here for several months, the young man handed a piece of workmanship to the latter, which could have been expected only after several years of work. The father said but little about it, and young Jean-Jacques felt so offended thereat, that he resolved to lay the file aside, and devote himself to study; consequently he ran away to Annecy, where he was received by Mrs. Warrens.

to the different European courts; the Court of Spain alone paid him 60,000 francs for such clocks, another one, as high as 80,000.

He also wrote a work on the art of horology, but since he understood better how to conduct the file than the pen, and was more familiar with the construction of a clock or watch than with that of a sentence of the French language, he had to call in the assistance of an abbé, who was instructor of his children. This work, however, has never been printed, because Lépine, several months before his death, almost completely lost his eye-sight, and, on the other hand, his honesty and the expenses which his experiments and inventions had cost, prevented him.

The manuscript was lost during the French Revolution. Even during his blindness, he invented another escapement, which he intended to have constructed by his grand-nephew, who was an excellent workman; this gentleman, however, was nominated to be Court jeweler to the King of Westphalia, and Lépine died at Paris, May 31, 1814, before the young man's return.

Sight.

WHAT THE OPTICIAN SHOULD KNOW ABOUT OPTICS.

Based upon an extensive hospital experience in Austria, Germany, England and New York. By C. A. BUCKLIN, M. D., New York. Author of Detection and Correction of Visual Imperfections, Cause and Cure of Cross Eyes, Effects of Color on Distance, and Monograph on Astigmatism.

Continued from page 52.

We have received the following inquiries:

LINDSAY, ONT., Feb. 27, 1883.

To the Editor of the Jewelers' Circular.

DEAR SIR: Your very kind reply to my letter published in THE CIRCULAR noted.

To be brief, after a long and careful test of patient's eyes we find—

1. Horizontal lines are blackest.
2. No. 50 bi-concave reverses and makes perpendicular lines black as horizontal lines were before, and horizontal lines dim as vertical lines were before.
3. No. 70 to 77 bi-concave equalizes all lines. I used $-28 +24$ to produce this effect.
4. Pin-hole in card always oval, long diameter vertical, no matter if strong bi-concave are used.
5. Sees no further without glasses than with, or *vice versa*. Block (largest) letters of June number seen fairly at thirty-five feet, or thereabout.
6. Left eye much *weaker* than right, but *similarly affected* vision with it (left), very hazy and dim at all distances.
7. Age, 38; sex, male; five years since trouble was noticed; color of eyes, black; previous to present occupation, railroad conductor.

The usual trouble in such cases, viz., that the eyes become tired, makes the result (within certain limits) vary. Have tried to be as accurate as possible by trying at intervals, and being as rapid as possible when trying, in order to avoid, as far as possible, fatigue.

With the above data, can you tell what is required, also what cost of glasses to correct such troubles generally would be.

With an apology for encroaching upon your time to this extent, and thanks for your trouble, I remain

Yours respectfully, J. BRITTON.

The results of Mr. B.'s experiments are in some respects contradictory, consequently I am severely taxed to give an intelligent answer to his inquiry.

He should have carefully tested each eye separately, giving us the acuteness of vision in each eye exactly, also the appearance of the radiating lines when seen separately, and the effects of the different lenses he tried upon each eye. If his acuteness of vision, as stated, is $\frac{3}{5}$ (June number), the horizontal lines are the darkest in each eye, and concave 50 will change the dark line from a horizontal to a vertical position. He must have a degree of myopic astigmatism not less than $\frac{1}{8}$, the sharper curve of the cornea must be in the horizontal meridian.

There may be a disease of the eye present which our questions do

not bring out. I should advise the man, if our attempted spectacle correction be not successful, to consult some expert oculist about his eyes at once.

Accepting the statement as correct that concave 50 will change the dark line from its horizontal to a vertical meridian, it follows that the vertical lines are made indistinct by being magnified too much by the horizontal curves of the cornea, where the astigmatism is slight the line running in the axis of the sharper curve looks blacker, because its thickness is measured and magnified by the *sharper* corneal curve. Placing concave glasses before this mild degree of astigmatism will not change the position of the dark line. When, however, any of the radiating lines (June number), owing to magnification of their thickness, become indistinct, concave glasses will change the position of the dark line to a position at right angles to this line.

As concave glasses do not measurably improve vision, we can exclude plain near-sightedness.

Statement No. 3 we must allow to pass, as it is wrong in every respect: $-28 +24 = +\frac{1}{13}$, or *convex* lens No. 193.

The experiment with the pin-hole confirms our supposition of astigmatism.

The varying results of experiments at different times is quite characteristic of *astigmatism*.

The only idea I can form of the degree of the *astigmatism* is the fact that letters which should be seen at *seventy* feet are "*fairly*" seen at thirty-five feet.

Supposing the reduction of the acuteness of vision to be due to simple astigmatism, I will venture to grind a pair of concave cylindrical lenses No. 30, axis vertical, round frames, and axis of each *lens* marked. He can cover one eye, and by tilting the frame up and down, find out if any change in the position of the axis improves vision. He may also try the lens with the axis (scratched on lens) horizontal. If there is any improvement with the lenses state it, as measured by our test (June number); also state if any change of axis improves the vision; if so, change the axis to the position which is most pleasing to the patient, and fasten the lens in the frame securely in this position, and return the spectacles to me by mail, and I will have the glasses constructed in any frame you desire. Should the lenses fail to improve vision, return them to me by mail, as I can always make use of them. *Urge upon the man the necessity of consulting an expert, if you cannot benefit him yourself.*

This case is certainly much more complicated than the one described in the March number of THE CIRCULAR.

WASHINGTON, D. C., Feb. 24.

Dear Sir: I write for some information concerning "*blurred vision.*" There are many cases here. People looking direct at an object cannot see it, the same as if the hand were placed before the eye, but there seems to be sufficient light to distinguish objects on either side of the eye, but not from the center. Information given me upon this matter will be most thankfully received by

Yours respectfully, H. H. HEMPLER.

The spots which blur central vision in the cases you mention are either upon the *cornea*, or in the posterior pole of the lens. In the former case, it is the result of a slough in the cornea caused by purulent ophthalmia during first few weeks of infantile period of life, or as the result of an herpetic ulcer upon the cornea. These ulcers are *very* frequent in malarious districts.

The difficulty is much more commonly due to an opaque spot in the posterior pole of the lens, left there by the artery which nourishes and develops the lens previous to birth, which at or before birth should break up and disappear completely. It however frequently fails to do so, as a result of which a round white spot is left in the posterior pole of the lens, which causes the peculiarities of vision you ask about. I have no doubt that every one of the cases you have seen are affected with this trouble. The case of Mr. Hitchcock, of this city, who is so widely known throughout the United States as "the cheap music dealer," is not without interest. Mr. H.'s *mother, aunt, uncle, sister* and daughter are all afflicted with this trouble. The difficulty may well be said to run in the family. The aunt,

some twenty years ago, fell into the hands of an old-fashioned physician, who, when patient was beyond the age of thirty, saw the small round spot deep in the pupil, and put a flat needle in the eye and attempted to dislodge the spot. The result was complete destruction of the eye in a few weeks, as always has been and always will be the result of this operation. The uncle, at seventy, fell into my hands. The lenses had become so thickened that he had to feel his way about with a cane. I removed the lens entire from his eye. In three weeks he could read the daily paper, and has resumed his business again.

Mr. H.'s case was just like the cases you have. He could see any way but straight ahead of him. If the light was shining in his face so as to make his pupils small, he could not see any distant object. I found that by dilating his pupil with a solution of atropine (two grains to the ounce), which was dropped into the eye, his distant vision was improved. With the lamp on a center table he could see faces the other side of the table distinctly, which he never could before. Having thus practically demonstrated what the results on distant vision would be, I removed a small piece of the iris from the nasal side, thus displacing the pupil so far inward that when looking straight ahead he could see objects around this spot. His condition has been very greatly improved. I am about to treat his daughter in the same manner. It frequently is found upon dilating the pupil, that there is not a large enough surface of the lens clear for an artificial pupil to be of any service. If this discovery be made before the eighteenth year, the case is an easy one to deal with. By carefully opening the anterior surface of the lens and allowing the aqueous fluid to come in contact with the substance of the lens, it will gradually absorb, and leave unobstructed vision with movable pupil.

The habit of carefully examining children's eyes, if they have any peculiarity of vision, should be generally cultivated. During youth the lens is so soft that it may easily be caused to absorb and disappear. After the fifteenth year the difficulties rapidly increase.

How to See the Spots.—Dilate the pupils with drop of atropia sulph., two grains to the ounce, and carefully focus the oblique rays of light from a lamp with a convex lens, No. 2½, on the dark pupil, as already described in March number of THE CIRCULAR. You will see a round gray spot deep in the pupil. Nothing but atropine and operative treatment, which is free of danger in competent and experienced hands, can remove the spots or improve the vision.

If the opacity is in the cornea you will see it the moment you focus oblique light upon it.

It is plain to see, where the spots are small and centrally located, how persons afflicted can see all around them but cannot see through them.

CONNEAUTVILLE, PA., Feb. 10.

Dr. C. A. BUCKLIN, M. D.

Dear Sir: Having read your book published by The Spencer Optical Manufacturing Company, and being desirous to learn the use of the ophthalmoscope, would you be so kind as to inform me what you consider the best treatise on that work, and also tell me where it can be obtained? What make of ophthalmoscope would you recommend me to purchase?

Enclosed please find stamp for reply. Awaiting your answer, I remain
Yours respectfully, C. C. JAXTHEIMER.

I do not think there is any work on the ophthalmoscope which is sufficiently practical to enable one to instruct himself how to use the ophthalmoscope. Ludwig Mauthner's work on the ophthalmoscope is the only work I am acquainted with which makes the subject complete. It is in the German language only, and is so purely scientific and mathematical that it will make most *specialists* "sick" who attempt to read it.

The best ophthalmoscope in the market may be had of Miller Bros., 1213 Broadway. It costs twenty-five dollars. It contains in the disk behind the mirror fourteen *convex* lenses, fifteen *concave* lenses, and two *condensing* lenses.

While I cannot advise the readers of our journal who cannot have

an opportunity to receive practical instruction, to attempt to learn to use the ophthalmoscope for the detection of visual imperfections, I would rather advise a thorough understanding of the theory of optics, and continual practice with test glasses. Everyone can try *THIS* method, and become expert in correcting visual imperfections. I will, however, for the benefit of our readers, tell you all I can about the practical use of the ophthalmoscope.

How to Examine an Eye.—A person complaining about his eye comes to you to find out what the trouble is; perhaps, by using the tests we gave in the June number, and following the directions already given, you find that there is a simple visual defect which requires a glass. Your test may not give you any information as to what the trouble is. If one complains of the eye being irritable, you carefully examine the under side of the lids and look for foreign bodies—the light should fall from the window obliquely upon the eye. If you do not find anything, take a 2½ convex lens and focus the light upon the cornea. While the light is thus condensed upon the cornea, take another 2½ inch convex lens and carefully examine the entire surface of the cornea. I have found five pieces of glass upon the eye by this method, which were perfectly invisible to the naked eye, and which had been already overlooked by several expert observers. If the day is not bright, place the patient in a dark room, with the lamp a little to the *right* for the right eye, and a little to the left for the *left* eye. With a lens in each hand carefully focus the light upon the eye, and through the other lens carefully examine the cornea. If there is any speck on the eye you will certainly see it. This method will also bring to view any opacities which are on the cornea, in aqueous chamber, upon or in the substance of the lens, which obstruct vision. If the trouble complained of be obscured vision, and its cause be not found by this method, it must be in the vitreous chamber, the retina, optic nerve, or brain. Before the ophthalmoscope was invented, all the diseases which were not found by this method were called *amaurosis*, a term which then indicated that the physician knew as little as the patient about the cause of his poor vision.

The ophthalmoscope, which was invented by Helmholtz in 1851, enables us to see what is taking place within the globe of the eye, and the optic nerve is also brought into view, as well as the blood-vessels which nourish the eye.

A normal eye when at rest just brings rays of light which come from distant objects to a sharp focus upon the retina, consequently, if we direct a person having normal eyes to look straight ahead, and we, in a darkened room, reflect the light of a lamp which is behind the person with our ophthalmoscopic mirror in such a way that the little dark shadow cast by the perforation through the centre of the mirror falls exactly on the dark pupil, the rays of light which enter the eye come in contact with the retina and optic nerve, and are reflected from this surface back to the eye of the observer. His eye, being normal and at rest, observes through the perforation the entire details of the optic nerve and retina.

If the observed eye and the observer's eye be normal, and the accommodation of both eyes is at rest, no glass behind the mirror will be required.

If the observer's eye be normal the strongest convex glass through which he can see the fine granular appearance of the retina distinctly will represent the amount of far-sightedness, independent of any statement from the patient. If the image is not distinct, and every convex glass makes the retina less distinct, begin with weak concave lenses. The weakest lens which makes the fundus *perfectly* distinct will represent the amount of near-sightedness, independent of the patient's statement.

If the *observer's* eye is not normal, a suitable lens to correct his visual imperfection must always be allowed for.

How to Determine if the Observer's Eye is Normal.—If he can read the last line of block letters in the June number at twenty-five feet, he is neither near-sighted or astigmatic. If all convex glasses higher than thirty-six make the letters less distinct, he is not far-sighted.

If he is far-sighted, the strongest convex glass through which he can distinctly read the letters at twenty-five feet represents the degree of far-sightedness he should allow for in examining other eyes. If he is near-sighted, the weakest concave lens through which he can read the letters at twenty-five feet will represent the concave glass he must allow for in examining other eyes. One must be able to look through the ophthalmoscope just as if he were looking at some distant object, and entirely forget that the object he wishes to see is near to him, otherwise he can do nothing.

The indirect method of using the ophthalmoscope is of no use in determining visual imperfection, consequently I will not give it. The method we have described is the "*direct method*." The theory is very simple, but considerable practical experience is required before one succeeds.

I shall investigate and see if there is not a small practical treatise on the use of the ophthalmoscope. The amount of presbyopia, or *old sight*, cannot be measured by the ophthalmoscope.

ELLSWORTH, MAINE, March 2.

C. A. BUCKLIN, M. D.

I have been very much interested in your articles on "Sight," in THE CIRCULAR. I have a number of customers who, I think, are troubled with astigmatism. I would like to inquire if you furnish glasses for them to the trade, and if so what are your prices? Also, can you inform me where I can obtain test cards like that in June number of THE CIRCULAR. I want something suitable to hang upon the wall for fitting.

I would suggest, for the benefit of your readers, that you inform them where they may be obtained, in some future article in THE CIRCULAR. Yours truly, E. F. ROBINSON.

I have gotten out for the Spencer Optical Manufacturing Company, 13 Maiden Lane, just what you ask for to hang on your wall. They will send it to anyone upon application, free of charge.

Lenses for astigmatic persons must be ground to order for each special case. You are not certain of finding any two cases which are exactly alike. I have not been able to satisfy myself that it is possible for any expert to determine the cylindrical glass required by an astigmatic person without seeing the person. I have several experiments now pending, where I am trying to determine the required correcting lenses from the results of a set of experiments conducted by an unskilled observer. I can give you the price of any lens you may wish to order, but the trouble is to tell just what kind of a lens is required.

One who has marked astigmatism should not consider time or trouble in having it properly corrected. They never know what comfort is until it is perfectly corrected.

I wish, as a closing remark, to call your attention to some facts that experience has forced upon me regarding *eye-glasses*. Never give a person with a large head a small eye-glass. Frameless eye-glasses are very agreeable to those who are obliged to wear their glasses continually. They are very unsatisfactory to those who use their glasses only to read. Celluloid eye-glass frames, *with steel-plated springs, are the most satisfactory*. I find that celluloid eye-glasses with the yellow composition springs are not as durable or satisfactory.

I find other compositions in the market which are made in imitation of celluloid, from which the acid used in manufacturing has not been properly removed. It is said not only to eat the metallic connections on the eye-glass, but to rust other steel goods with which it comes in contact. It will be remembered that there were the same difficulties about celluloid when it first was placed upon the market.

The Horological School at Glasshutte.

WE HAVE received from the able director, Mr. Moritz Grossmann, the fourth annual report of the Horological School of Glasshütte, and want of space alone prevents us from laying the entire document before our readers; we are compelled, therefore, to extract a few of its most interesting features.

The report opens with the statement that, owing to the largely

increasing number of pupils, it became necessary to erect a larger and more commodious building, which was dedicated and opened on May 1, 1881.

The scholastic year beginning May 1, 1882, opened with a total number of 42 permanent pupils, the same number as last year, which was swelled to an average of 56 pupils by visitors who studied special branches. The pupils are accredited to the several German countries, as well as to Hungary, Russia, Switzerland, Norway, Holland, and the United States.

The curriculum embraces: Physics, theoretical horology, French, arithmetic, geometry, mechanics, drawing, book-keeping and English.

The directors speak in terms of highest praise of the advance made by the scholars, and deem the fact that so many pupils come from foreign countries a subject of special congratulation, more than one-fifth of the scholars being non-Germans.

Owing to some complications in the financial receipts, the assets could only be given approximately, but it is confidently expressed that the sheet will balance with a satisfactory amount of cash on hand.

The directory for the current year consists of Messrs. M. Grossmann, President; J. Assmann, F. Weichold, Committee on Finance; C. Schaarschmidt, G. Gessner, on Rooms; R. Lange, L. Strasser, C. Kohl and C. Jentsch, Executive Committee.

The teachers are G. H. Lindemann, Director of school; G. A. Hesse and Julius Bergter, teachers of practical horology; K. L. Strasser and K. M. Grossmann, teachers of theoretical horology; M. Grossmann, teacher of English.

Parties in the United States demanding information may forward their demands to Moritz Grossmann, Glasshütte, Saxony.

Spirits of Lavender for Strengthening the Eyes.

EVERY eminent German horologist, B. Morgossy, addressing his fellow watchmakers, says that to those who have strained their eyesight by very delicate and long continued labor with the magnifier, or by long reading in unduly bright light, and suffer with weakness of the eyes, or occasionally have a trembling of vision, he would most urgently recommend a very efficacious, and at the same time simple remedy, which he has used for a long time with the happiest results—spirits of lavender, to be had in every drug store. It is to be used as follows: To two parts spirits of lavender, add one part clean river, spring, or distilled water from the drug store, and after every fatiguing work with the magnifier, and evenings before going to bed, as well as in the morning after washing with lukewarm water, rub in with a moist linen or cotton rag, on the eyebrows as well as forehead, but at least one-half hour before going out into open air; in case of complete weakness, use it five or six times. He recommends the daily application of this fluid, especially to those of his colleagues who suffer with weakened eye-sight, and are compelled to labor or read for a long time every day. Moreover, when working by the assistance of a lamp, a dark blue or green paper upon the bench should always be substituted in place of the white; the eyes are greatly relieved thereby.

The Crowning of the Czar.

THE CROWN to be worn at the approaching coronation of the Emperor of Russia dates from the year 1763, and is the masterpiece of the Court jeweler, Jeremiah Panzio, a native of Geneva, who made it for the coronation of the Empress Catherine II. Its chief ornament is the Orlof diamond, which is said to weigh 779 karats, and to be worth 30,000,000 roubles. It formerly belonged to the Brahmin temple at Tcherigam, and was stolen by a French grenadier, when it came into possession of Prince Orlof, who presented it to the Empress. The scepter, too, made by order of Paul I., is adorned with a diamond of 195 karats, bought by Catherine II., from an Armenian, for 450,000 roubles. Its present worth is estimated at 30,000,000 roubles. This brilliant diamond formed one eye of the massive golden lion on the throne of the Shah Nadir; the other eye was the famous Koh-i-Noor now in the possession of the Queen of England.

Lathes and Lathe Work.

BY THE MODEL WATCHMAKER.

IN REPAIRING English lever watches, the wear of the pivot holes compels closing or bushing in a larger majority of cases, and as a rule bushing is far preferable. To bush a hole nicely takes but a very few minutes, and still it is looked upon by many watchmakers as quite a serious job. The simplest form of bush is but a piece of hard brass wire drilled to near the size of the pivot, driven or forced into the hole to be bushed. The advantages of bushing are many; it not only makes the hole fit the pivot but it can be made to correct the depthing, if any fault exists at the same time, by throwing the hole a little to one side at the time it is enlarged for the bush. I will first describe the method of proceeding if you use an American lathe, and then how to go about it if you use a Bottum or Swiss wax chuck.

With an American lathe, select a piece of hard brass wire of the size required, and with a sharp graver center it as if you were going to pivot it; then with a drill a trifle smaller than the pivot to run in the bush, drill a hole on the line *d*, fig. 1. This hole need not be drilled much deeper than the thickness of the plate to be bushed. After the hole is drilled, the end of the wire up to the line *a b*, should be turned true to fit the hole (enlarged) to be bushed. At the point *a*, which is supposed to be the end or bottom of the drilled hole, a groove should be turned so that the bush will break off easily at this point. If the brass bush is free from oil or moisture, and the hole in the plate is in the same condition, they will, on turning or revolving the bush in the hole, adhere or weld to some extent, and securely

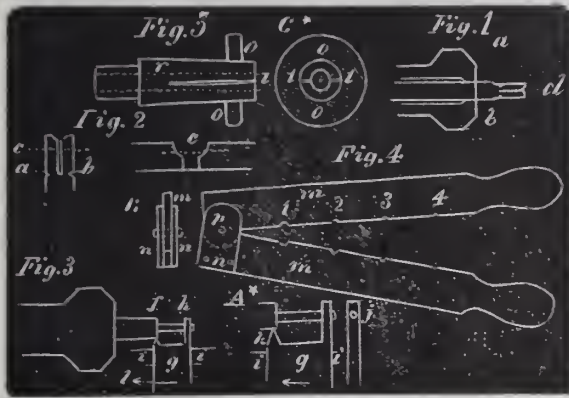

hold the bush in place. A bush should always be inserted on the inside of the plate, as there is less tendency to push inward than outward.

By using a little care and judgment, the hole in the plate can be gradually broached out until the bush can be pushed in until the groove on the line *a b* will correspond to the inner surface of the plate, and the outer end filed off on the line *c*, until, when inserted in the plate, it will only come a little more than flush with the countersink *c*, fig. 2; the portion which protrudes above the countersink can be removed with one of those Swiss round countersinks which corresponds to the curve of the oil sink *c*. The inner end can be carefully touched with a file, or if you have a universal lathe faced off in this. Sometimes it may be necessary to use soft solder to secure a bush; if it really is, use it, but do not smear the plate all over with it. A very fine screw can be used to secure a bush in position; in this case the screw is cut on the bush in the lathe. The screw should be very fine, *i. e.*, about like the plate screws to American banking pins. The taps for such screws will have to be made, and they are not by any means difficult to make. Take a piece of steel wire as shown at fig. 3, and put it in your lathe and turn it to the size to cut a thread in your Swiss screw plate.

It is best to explain a little; you should calculate to make three or four sizes of bushes; the largest about $\frac{1}{8}$ of an inch in diameter, to be used for English and Swiss center holes. The second size about $\frac{1}{16}$, the third size about $\frac{1}{32}$, and the fourth size about $\frac{1}{64}$. To get the fine thread, take a piece of steel wire a trifle too large for the tap (say the largest size, $\frac{1}{8}$ of an inch) and turn the part from *f* to

h, fig. 3, to the right size to cut a thread in the No. 6 hole of your Swiss (hole) screw plate. After it is turned to size, without removing the wire from the lathe, cut a screw on the part from *f* to *h*, by revolving the foot wheel slowly back and forth with the left hand, the right holding the screw plate. In cutting a screw, as at *h*, the turned part should be no larger than to fill the thread in the plate, so as not to force it, and consequently curve it out of true. The writer begs leave to digress long enough to say a word or two on turning to make screws for watches; and sometimes one is compelled to make a screw. Most watchmakers have experienced the difficulty that if one cuts tap and screw both in the same plate, that the screw will seem invariably to be the largest, consequently, the made screw will stick and bind in the hole after it is tapped out. This can be remedied by turning the tap as *large* as can safely cut without breaking off in the hole, and the screw as *small* as will form a full thread. If such a screw is hardened, it will hold all right, and run easily into the tapped hole. The explanation of this is, that in cutting a screw in a solid plate, the thread is raised in a burr quite as much as it is cut; and in the case of the smaller screw, the burr is not raised so much, and consequently the screw, although looking perfect, does not quite fill the threads; but the hardening makes it durable enough for all practical purposes. The part of the steel wire from *f* to *h* should be cut as directed above, and if by accident bent a little, should be straightened in the lathe, but not removed.

Now for transferring the thread from our small diameter to the larger: A tool is shown separate at *A**, made of steel; an old flat file softened answers well; it is shaped as shown. At *j* a hole is drilled and tapped to fit the screw on *h*. At *k* is a cutting point as shown; the angle in the cut is about right. This tool is made and hardened, and used as shown; the end of the screw on *h* is inserted in the hole at *j*, and the piece *g*, supported on the tool rest shown at *i*, diagram *A**. The reader will see that if the lathe is turned slowly and the tool *g* swung round in the direction of the arrow *l*, that the point *k* will attack the larger portion of the steel wire and cut a thread, not entirely at one operation, but by a repeated system of chasing. The left hand should be used to turn the wheel, turning it back and forth as directed for cutting the screw on *h*. The large chased screw should be turned with a little taper. After the tap is turned to perfect screw it should be removed from the lathe and hardened and used to make a die plate. The best form of die plate for this purpose is shown at fig. 4, *m m*, being of steel; the pieces *n n* of brass or steel, and forming the joint. *B** is an end view. The holes are in the order designated by the figures, and the construction of the joint must be obvious in the cut. This plate is used to cut a screw on a brass bush in the lathe—the brass bush being turned to the proper size, and the hole in the watch plate is tapped with the turned tap above described. The method of using the plate is to open it and close it on the brass bush; then *unscrew* the bush out of it, cutting the thread as it unscrews by turning the lathe wheel backward. The brass bush should, like the tap, be slightly taper. The hole for the pivot should be drilled before the screw is cut.

If for a Swiss or Bottum lathe, a chuck shown in fig. 5 is used; it is simply a piece of large brass wire like the ordinary wax chuck, but drilled so as to admit brass wire large enough for the largest size of bush. One chuck can be used for all sizes of bushes, as it is quite easy to turn the wire down to the size required. This chuck serves also to hold the steel wire for the fine thread tap. After the hole is drilled the chuck is turned slightly taper, and a brass collar of thick (No. 14) sheet brass, as shown at *o o*, fig. 5; this collar has a milled edge, and serves like ring on a pin slide to clamp the wire to be turned in the chuck. The taps for the holes in the plate should be chased with proportionate threads, as we said for the largest bush, No. 6, Swiss screw plate; the next size in No. 9, the next in No. 12 and the last in No. 15.

Even if you make but two sizes of bushes you will find them to answer for most all jobs; these sizes are $\frac{1}{8}$ and $\frac{1}{16}$. The manner of inserting these bushes is to try them in the hole already tapped out, cutting the end off so they will screw in to the right distance, and then proceed as described for the simpler plain bush. A screw bush is by far the best method of bushing. I should have said the chuck shown in fig. 5, as shown at *l* down to *r*.

Correct Local Time and How to Obtain it.

THE WRITER feels the importance of the task in offering anything new in the shape of a timekeeper, and begs it not to be understood that he has made any important discoveries, or hit on any new or startling method by which the human family is going to know exactly how Father Time is winging his flight; but rather to combine from the experience of others and himself such an arrangement of parts and principles as will give the best results. As a starting point it is well to give a short *resumé* of the factors involved in the problem we now have in hand. It is universally acknowledged that a pendulum of some kind is the best method at our disposal for regulating and controlling any mechanism for the measurement of time; and if it was not for the action of disturbing influences we should have a perfect measure for intervals of time proportionate to the length of our pendulum. But, as has been explained in former articles, heat expands our rod; hence our clock or timekeeper runs slower in summer. We have explained how to correct this. We have also pointed out the error produced by unequal forces being applied to keep the pendulum in motion. To remedy this we have described an electric method by the use of which the motive power cannot be increased or diminished the one-thousandth of a grain. A plan also has been pointed out to obviate almost perfectly the action and disturbance of the jar of traffic. And now remains for us to give the details of a plan for correcting barometric influence; that is, we desire to have our pendulum perform its vibrations in precisely the same time when the barometer marks 30 inches as when it marks 29. About the simplest way to accomplish this is by using a modified form of the aneroid barometer. Probably most of my readers know perfectly the action of the aneroid barometer; and in order to make use of this principle to correct our pendulum we must procure one of the vacuum drums used in such a barometer. To those who understand the action of one of these drums we beg indulgence while we explain its action to those less fortunate. It is a well-established fact that the air, or atmosphere, does not always press on the earth with exactly the same force. The pressure of the earth's atmosphere was first noticed in conjunction with the air-pump; or, rather, the phenomenæ presented by the action of the air as shown by the common suction pump. This led various investigators to understand the nature of the force the air exerts on the earth's surface. Experiments showed that the air surrounding the earth at sea level exerted a pressure of about fifteen pounds to the square inch, and would raise a column of water in a tube from which the air was exhausted to the height of 32 or 33 feet, and a column of mercury to the height of about 30 inches. Now, as mercury is about $15\frac{1}{2}$ times as heavy as water, we can readily see how that the short column of mercury could match or equal the high column of water. In making the experiments with columns of water and mercury, it was observed that the height to which the columns of water or mercury were raised fluctuated, and that on some days the column of water against a vacuum would not rise more than 31 feet, or a column of mercury would not rise more than 29 inches, while on some rare occasions the column of mercury would rise to nearly 31 inches and the column of water to over 33 feet. These fluctuations were also noticed to correspond to terrestrial storms, and led to a very general use of the mercurial barometer as a means of pre-judging the weather. The inconveniences of the mercurial barometer for marine purposes led to the invention of the aneroid barometer. This last-mentioned instrument being the one we have selected to use its principles as a means of correcting the influence of a denser atmosphere, we will briefly describe it. It hardly seems necessary to say that, as air is an elastic fluid, the greater its density the greater its resistance to a moving body; consequently a pendulum beating exact seconds in air indicating a pressure of 29 inches of mercury, would fall off a little in rate if vibrating in air indicating 30 inches of mercury. We will first consider the principle involved in the aneroid barometer, and then show how it can be applied to correcting the resistance of a

denser atmosphere to a pendulum. To construct an aneroid barometer two discs of hard-rolled copper are corrugated in concentric rings, while the edge is turned up in a lip. At fig. 1 is shown a plan of such a disc, and *d d*, shows the corrugations. Fig. 2 is a vertical section of the same, showing how the two discs are united by the lips *a a*. These lips are joined by soft solder, and at some convenient place, as at *c*; there is a small tube inserted to which an air-pump is applied. Generally the air is not perfectly exhausted, but about one-half; that is, the pressure of the air against the sides is about 7 or 8 pounds to the square inch. To one of the discs is attached a support, as shown at *b*. This support is firmly fastened to the case or frame of the instrument. It must be evident to the reader that as the space *B* between the two discs is a partial vacuum, the external air has a constant tendency to close them together. This force is met by the rigidity of the metal; but as the discs are elastic (increased by the corrugations), they yield back and forth proportionate to the pressure the external air exerts. Now, apply some mechanical device by which this yielding can be magnified and shown, and we have an aneroid barometer. To apply this principle to the case in hand we must devise some method by which the yielding of

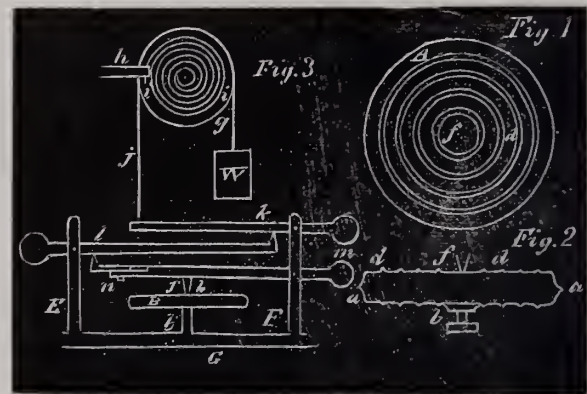

the elastic disc can be made to move a weight, or offer more or less resisting surface to the air, proportionate to the increased density of the air the pendulum is vibrating in. The plan of raising and lowering a small weight will be first considered, as on many accounts it seems the most practicable. At fig. 3 is shown an elevation of a device by which a small mass of matter (a weight, in fact) can be raised and lowered at a trivial expense of power. *D* represents a small wheel, and *g* a very flexible piece of fusee chain. The chain is wrapped around the wheel *D*, and descends to the weight *W*. At *n* is shown a stud. This stud is attached to the frame of the compensation device, and holds the outer end of a flat coiled spring, like a very coarse hair spring. Opposite to *g* is another piece of fusee chain descending to the lever *k*. The opening *i* is adjusted up to such tension that it will almost lift the weight *w*, and the lever *k* exerts force enough on the chain *j* to raise the weight *w* if *k* descends. It will be seen on inspection of Fig. 3 that the corrugated chamber *B*, supported by the column *b*, is free to feel and act by any change in the density of the atmosphere. *E* and *F* are supports rising from the bed-piece *G*, and into these supports are mortised the levers *m l k*. These levers are perfectly poised on three joint pins, so that a grain or two in weight in excess on the lever *k* will cause the point *f* to press on the upper disc of *B*. It is evident that any increase in the density of the atmosphere which offers an increased resistance to our pendulum ball will slightly collapse the chamber *B*, when the point *f* will follow and the weight *w* be raised, and consequently the center of oscillation will be raised to such a degree as to compensate for the falling off of rate consequent on the increased density of the air in which the pendulum swings. The bar *m* is adjustable at *n* with a slide, so as to change the compensation for adjustment. The whole of this compensation is enclosed in a ring and placed at the top of the pendulum ball. The novelty of this arrangement is that it can be held in check until all the other adjustments are thoroughly tested; then it can be applied and no way affect the rate or heat and cold adjustment. The exact details will be given in our next.

Foreign Gossip.

POSTAL CARDS WITH ANSWER.—Great Britain also has joined those countries of the World's Postal Union, to which postal cards with answers may be sent. The postage is 5 cents.

TRANSIT OF VENUS.—After good news had been obtained from three German expeditions sent out to observe the transit of Venus, cheering words of the excellent success have also been heard from the fourth and last, stationed at Punta Arenas, at the southern point of America. It was favored with excellent weather to such a degree that measurements of an unexpected completeness have been obtained by Professor Dr. Anwers.

THE TUNING FORK.—Experiments are instituted in Prussian artillery target practice to ascertain the velocity of the ball within the cannon by means of the vibrations of a tuning fork, which records them by means of a small pin fastened to one of its arms; it has also been much used lately for measuring the smallest intervals of time. The French colonel, Severs, experimented with it, and obtained very satisfactory results. The tuning fork, set in motion by the explosion of the powder, makes from 2,000 to 3,000 vibrations per second, which are marked upon a sheet of paper; not visible, however, to the naked eye, and seen only by assistance of the microscope.

INTERNATIONAL ELECTRIC EXPOSITION.—Notifications for participation in the International Electric Exposition, to be held in Vienna, from August 1 to October 31, 1883, come in very plentifully from all sides, and show the great interest with which the technical world supports the enterprise. Although special invitations have been sent by the Exposition Committee to all known firms, still it is very possible that many have been overlooked who desire to participate. Such firms may obtain the general regulations and notification sheet at the Austro-Hungarian Consulates or by the Directing Committee Vienna I, Wallfischgasse 9a, the latter of which will answer to all demands.

LECLANCHE.—George Leclanché was one of those inventors who, by a single happy invention, earned a world's reputation. His cell or element is known everywhere where the telegraph has penetrated, and the inventor's demise last fall in Paris awakened the sympathy of the entire scientific world. He obtained his education in the "Ecole Centrale des Arts et Manufactures," and obtained a position in the laboratory of the "Compagnie de chemins de fer de l'Etat," as chemistry engineer for the railroad companies of France. He remained here until 1867, when he obtained a patent for his celebrated battery. He experimented in the latter part of his life to devise a system of time division for annotating chronometers (chronographs) by means of electricity. Leclanché reached an age only of 43 years.

A WORLD-MOVING WORD.—The scientist who, according to irrefutable evidence, first made use of the expression "electricity," which is threatening to depose steam from its universal sovereignty, was an English doctor by the name of William Gilbert, who lived in the sixteenth century. He published in 1600, in London, a work by the title "De Magnete, magneticisque corporibus et de magno magnete tellura Physiologia nova." In this work, which already contains the main principles of the earth's magnetism, occurs the following sentence: "Vim illam electricam nobis placet appellare quae ab humore provenit." William Gilbert, born in Colchester in 1540, died Nov. 13, 1603, in London. He was confidential physician to Queen Elizabeth, and afterward to King Jacob I., and a very intimate friend of Lord Bacon. His work, "De Magnete," contains a number of interesting experiments. It met with less publicity and fame in England than in foreign countries, because, since 1628, five editions appeared in Germany, three in France, and only two in England.

IMITATION WATCHES.—About a century ago the fashionable world wore two watches, the chains and charms of which dangled toward the right and left upon the embroidered vest. This fashion was also adopted by the ladies; but since it was generally too costly to wear two real watches, people were mostly satisfied with a real watch to the left and an imitation one to the right. The latter was frequently ornamented with gold, silver, jewelry or miniature painting; the face of others was provided with a dial. Some were satisfied with wearing a needle cushion instead, in fact all manners of excess was committed in this line. The most costly imitations were ornamented with stars and allegories, composed of jewels, which could be revolved by means of special wheel-work. People who had no money to spend for such luxuries were satisfied with wearing a simple gold or painted case. Only the Chinese at present wear two watches, disposed of in two small embroidered pockets.

THE VOLTA PRIZE COMPETITION OF 50,000 FRANCS.—The French Department of Public Works has recently communicated to the President of the Academie of Sciences the conditions of the Volta prize to be competed for in the year 1887. After a general explanation of the importance of the Voltaic column, follow the five articles for competition: 1. The prize of 50,000 francs, established by resolution dated June 11, 1882, will be given as a reward to the author of a discovery making electricity suitable to be adapted in an economical manner to the following uses: As source of heat, light, chemical operation, mechanical force, as means for sending dispatches, or for the treatment of sickness. 2. Scientific men of all nations are admitted to competition. 3. Competitive documents will be received up to June 30, 1887. 4. A committee, to be nominated by the Secretary of Public Works, will test the discoveries of each competitor, and decide to whom the prize shall be awarded.

INTERNATIONAL MERIDIAN.—As is well known, the U. S. Government has proposed a uniform international meridian in a diplomatic circular addressed to the several civilized nations. A very great service would be rendered both to shipping interests and geographical science by the universal adoption of this measure. But it is, unhappily, to be feared that petty national jealousies will also, in this case, thwart the proposal. While Germany would undoubtedly sacrifice its ancient, almost obsolete, meridian of Ferro for a more modern sensible one, the case is more doubtful already with France, whether they would patiently resign the meridian of "Paris;" and when we come to England the case is still more dubious. London papers already claim that Great Britain, as the first commercial, marine and colonial power, should, under all circumstances, have the exclusive right of giving the deciding vote. This, when practically interpreted, means nothing less than that England retains its Greenwich meridian also for the future, and all other nations adopt it without further cavil.

EARTH MAGNETISM.—The magnetism of the earth is still an unsolved problem. Professors Ayrton and Perry lately published an hypothesis, that the earth was loaded with static electricity, which, by reason of the revolution of the earth, operated like a circulating current and magnetized its core. This hypothesis, however, suffered a sad blow by the mathematical criticism of Professor Rowland, who explained that the charge necessary for the surface would also be strong enough to send a spark from the earth to the moon. Another theory is based upon the presence of an electric current in the air surrounding the earth. Proceeding from the idea of M. Edlund, that an electric current is nothing else than a current of ether, which flows in the revolution, and that electro-static effects were due to the rarefaction and condensation of the air, M. Selim Lemström sought to produce such an ether current in a mechanical way. If a double tube of paper is set into rotation with a core of soft iron, this will become magnetized, as proven by two fine astatic needles. Upon reversing the rotation, also the magnetic poles will reverse. M. Lemström deduces therefrom the relative motion of the ether in the rotating tube to be the cause of polarity. If the tube were stationary, and the core revolve, a similar effect would be obtained.

Workshop Notes.

GOLD TINGE.—A bright gold tinge may be given to silver by steeping it for a suitable length of time in a weak solution of sulphuric acid and water, strongly impregnated with iron rust.

MELTING GOLD.—In melting gold use none other than a charcoal fire, and during the process sprinkle saltpeter and potash into the crucible occasionally. Do not attempt to melt with stone coal, as it renders the metal brittle and otherwise imperfect.

JEWELERS' CEMENT.—Put in a bottle two ounces of isinglass and one ounce of the best gum arabic, cover them with proof spirits, cork loosely and place the bottle in a vessel of water, and boil it till a thorough solution is effected; then strain for use.

GOLD AND SILVER FROM TEXTILES.—Cut into pieces the gold or silver lace, tie it tightly, and boil in soap lye till the size appears diminished; take the cloth out of the liquid, and after repeated rinsings of cold water, beat it with a mallet to draw out the alkali. Open the linen, and the pure metal will be found in all its beauty.

COLD SILVERING OF METALS.—Mix 1 part of chloride of silver with 3 parts of pearl ash, $1\frac{1}{2}$ parts common salt, and 1 part whiting; and well rub the mixture on the surface of brass or copper (previously well cleaned), by means of a piece of soft leather, or a cork moistened with water and dipped in the powder. When properly silvered, the metal should be well washed in hot water, slightly alkalized, then wiped dry.

REFINING SILVER.—After having rolled the silver, cut it into narrow strips, and curled it to prevent its lying flat, the pieces are dropped into a vessel containing two ounces of good nitric acid diluted with one-half ounce pure rain water. When the silver has entirely disappeared, add to the two and a half ounces of solution nearly one quart of pure rain water. Then sink a sheet of clean copper into it; the silver will collect rapidly upon the copper, and you can scrape it off and melt it in bulk.

SOFT-SOLDERING ARTICLES.—Moisten the parts to be united with soldering fluid; then, having joined them together, lay a small piece of solder upon the joint, and hold over your lamp, or direct the blaze upon it with your blowpipe until fusion is apparent. Withdraw them from the blaze immediately, since too much heat will render the solder brittle and unsatisfactory. When the parts to be joined can be made to spring or press against each other, it is best to place a thin piece of solder between them before exposing to the lamp. Where two smooth surfaces are to be soldered one upon the other, you may make an excellent job by moistening them with the fluid, and then, having placed a sheet of tin foil between them, holding them pressed firmly together over your lamp till the foil melts. If the surfaces fit nicely, a joint may be made in this way so close as to be almost imperceptible. The bright looking lead, which comes as a lining of tea boxes, is better than tin foil.

TINTING METALLIC SURFACES.—It is found that metallic objects may be attractively colored by immersing them in a bath formed of 630 grains of lead acetate dissolved in 3,450 grains of water, and warmed from 88° to 90° F. This mixture gives a precipitate of lead in black flakes, and when the object is plunged into the bath, the precipitate deposits upon it; the color acquired depends on the thickness of the skin, and uniformity of tint is insured by gradual treatment. There is thus imparted to iron a bluish aspect like steel; zinc, on the other hand, becomes brown. By employing an equal quantity of sulphuric acid in the place of the lead acetate, and warming a little more than in the first case, common bronze may be colored red or green with a very durable skin. And not only this, but beautiful imitations of marble are obtained by covering bronze objects, warmed to 100° F., with a solution of lead thickened with gum tragacanth, and afterward submitting them to the action of the above-named precipitate of lead.

BRIGHTENING ELECTRO-PLATE SILVERWARE.—The tarnish on electro-plate goods may be removed by immersing the article from one to ten or fifteen minutes, or until the tarnish has been removed, but no longer, in the following solution: Rain water, 2 gallons; potassium cyanuret, $\frac{1}{2}$ pound; dissolve and put into stone jug or jar and closely cork. After immersion, the articles must be taken out and thoroughly rinsed in two or three waters, then dried with a soft linen cloth, or, if frosted or chased work, with fine, clean sawdust. Tarnished jewelry may be speedily restored by this process; but make sure work of removing the alkali; otherwise it will corrode the goods.

TO REFINE GOLD.—If you desire to refine gold from the baser metals, swedge or roll it out very thin, then cut into narrow strips and curl up so as to prevent its lying flatly. Drop the pieces thus prepared into a vessel containing good nitric acid, in the proportion of acid, 2 ounces, and pure rain water, $\frac{1}{2}$ ounce. Suffer to remain until thoroughly dissolved, which will be the case in from one-half to one hour. Then pour off the liquid carefully, and you will find the gold in the form of yellow powder, lying at the bottom of the vessel. Wash it with pure water until it ceases to have an acid taste, after which you may melt and cast into any form you choose. Gold treated in this manner may be relied on as perfectly pure.

TESTS FOR DIAMONDS.—Hydrofluoric acid will not affect the diamond, while it quickly corrodes glass, which is the material of most of the imitation gems. The only objection to its use is that it will attack certain stones of minor but real value, like the topaz, which are sometimes passed off as diamonds. Of course, being a dangerous agent to experiment with, it must be employed with great caution. The following directions may be safely followed: Take a leaden vessel, of saucer shape and moderate size, in which place pulverized fluor spar, which cover with enough oil of vitriol to completely moisten the powder. Then put in the stone to be tested and gently warm the mixture over a gas lamp or any other convenient source of heat. This should be done in a good draught, where the vapors will be drawn up a chimney or dissipated, as they are dangerous to breathe. When the evolution of vapors appears to have ceased, which will occur in from five to fifteen minutes, according to the quantity of material employed, the heat should be withdrawn and the vessel allowed to cool. The stone may now be fished out from the pasty mess and examined. If it shows no sign of being attacked, you may be assured that it is a genuine diamond. A paste stone will be found to be strongly corroded by the acid that has come in contact with it, and if it was a small one, it will probably have been entirely dissolved.

SEPARATING SILVER.—The following simple method of separating silver out of alloys may be useful. It is described by Herr Gottheim: The silver-holding alloy or metals are dissolved in the least possible quantity of crude nitric acid. The solution is mixed with a strong excess of ammonia and filtered into a high cylinder, provided with a stopper. A bright strip of copper, long enough to project beyond the liquid, is next introduced, which quickly causes separation of pure metallic silver. The reduction is completed in a short time, and the reduced silver washed first with some ammoniacal solution and then with distilled water. The more ammoniacal and concentrated the solution, the more rapid the reduction. The strip of copper should not be too thin, as it is considerably attacked, and any little particles which might separate from a thin sheet would contaminate the silver. The operation is so simple that it seems preferable to all others for such operations as the preparation of nitrate of silver from old coins, etc. Any accompanying gold remains behind during the treatment of the metal or alloy with nitric acid, chloride of silver, produced by the impurities [HC] in the nitric acid) is taken up by the ammoniacal solution like the copper, and is also reduced to the metallic state; and whatever other metal is not left behind, oxidized by the nitric acid, is separated as hydrate (lead, bismuth), on treating with ammonia. Any arseniate which may have passed into the ammoniacal solution, is not decomposed by the copper.

Trade Gossip.

J. M. Geist's jewelry store at Duluth was recently destroyed by fire.

Wm. R. Jackson is now traveling for Miller Bros. in place of O. T. Smith.

The Melville watch, made exclusively for Henry May, is rapidly growing in popularity.

J. P. Libbey, of Sioux City, Iowa, has recently added a music department to his jewelry store.

There is a slight decline in diamonds of the lower grades. Fine goods are scarce and consequently firm.

Three million dollars worth of diamonds are said to have been worn at the Vanderbilt ball recently given in this city.

Walter H. Wainright, of the firm of E. J. Boyce, of Boston, having recently died, the business will be continued by E. J. Boyce.

Charles Glatz will open a branch office in the Jewelers' Exchange Building, Chicago, under the management of Simon Goldsmith.

J. K. Howe, Jr.'s jewelry store at Bloomington, Ind., was destroyed by fire on the morning of the 16th ult., loss not stated.

The dissolution of the firm of J. H. Purdy & Stein, of Chicago, is announced, and the business will be continued by J. H. Purdy & Co.

Colonel J. M. Rutherford, the popular jewelry auctioneer, has just been selling a stock of goods at Susquehanna for Charles A. Miller.

Alex. M. Hays & Co., for many years engaged in the clock, bronze and fancy goods business, have decided to retire from business on May 1.

A. S. Freund, of the firm of Max Freund & Co., sails in the *Servia* May 9. Max Meyerheimer, in the same firm, accompanies Mr. Freund.

The diamonds worn by bartenders in this city are said to be worth \$350,000 dollars. They can scarcely be considered gems of the first water.

W. M. Scott & Co., of Philadelphia, have recently introduced what they call "the lightning cleanser," for absorbing tarnish from gold, silver and plated ware.

Henderson & Winter have extended their office accommodations at No. 15 Maiden Lane, and have fitted up their offices in a very neat and attractive manner.

Frederick M. Simons, of the firm of Simons, Bro. & Co., of Philadelphia, was married March 15 to Miss Marion, daughter of H. V. Lesley, of Philadelphia.

F. Jeandheur, Jr., the well-known silver plater, whose establishment is located at 125 Fulton street, has been burnt out, and his stock damaged to the extent of \$5,000.

Charles Keller & Co. have removed to more desirable and commodious quarters in No. 9 Maiden Lane, which they have fitted up in a very neat and attractive style.

The 2,000,000th movement manufactured by the American Watch Company, goes to Geo. W. Ludwig, of Chambersburg, Pa., and not of Harrisburg, as we stated last month.

Louis Neresheimer, of the firm of E. August Neresheimer & Co., returned from Europe in the *Elbe*. While abroad he made extensive purchases of fine diamonds for his firm.

Burglars recently broke a large hole in the plate glass window of Dalhaner & Co.'s jewelry store, Cincinnati, and stole \$800 worth of jewelry from the show case and escaped.

The rooms occupied by George H. Richards, Jr., in Boston, were filled by smoke recently from a fire that occurred in the building, and plated ware injured to the extent of about \$1,000.

Two thieves implicated in the robbery of Vail's jewelry store, at Laport, Ind., have been arrested and a large quantity of goods recovered. The men are known to the police as expert criminals.

D. H. Buell, of Hartford, Conn., is exercising his gigantic intellect over a type-setting machine that will revolutionize the typographical art. The invention is highly spoken of by practical printers.

The firm of Jno. O. Slemmons & Co., of Pittsburg, has been dissolved by mutual consent, W. H. McCormick retiring. W. C. Hodge, Jno. O. Slemmons and Oscar G. Ganter have entered into a co-partnership under the firm name of Hodge, Slemmons & Co., for the purpose of conducting a wholesale jewelry business. The new firm have secured the second and third floors of No. 77 Fifth avenue, which they will occupy after April 1st.

William McDonald and Charles Howard, known as billiard cue hook thieves, who robbed several jewelry stores in this city and in Newark, have been sentenced each to fifteen years in the State prison.

Dean Southworth has been admitted to the firm of D. C. Percival & Co., of Boston. Mr. D. C. Percival has gone South for a brief recreation, and to escape the howling March winds that sweep over Boston Bay.

Messrs. Cox & Sedgwick have gone South with their families, and are now shooting alligators from the banks of the St. Johns. They are expected to return with many fresh ideas for new designs in jewelry with alligator finish.

C. F. Morrill, Alvin Morrill, George A. Gilmore and O. A. Drinkwater have formed a co-partnership for the transaction of a jobbing jewelry business in Boston. They have just issued a new price list to the trade, which will be sent on application to regular dealers.

The Windsor Link Cuff Button is the latest novelty in this class of goods. By patented mechanism, it is easily adjusted without injury to the cuffs or the temper of the wearer. An illustration in their advertisement elsewhere gives a good idea of the new device.

J. A. Brown & Co., the pioneers in the manufacture of filled cases, have disposed of their business and patents to the Ladd Watch Case Co., in which Brown & Co. have secured a large interest. The new company will continue the business established by J. A. Brown & Co.

M. S. Smith & Co. are erecting a new store in Woodward avenue, Detroit, which they hope to occupy some time in September. The interior decorations and furnishing are under the supervision of B. & W. B. Smith, the well-known show case manufacturers of this city.

Matrimony appears to have taken on a contagious phase in the trade. We have now to announce the marriage of Alvah Osmun, traveler for Unger Bros., to Miss M. Ward. The ceremony was performed on March 14, at the residence of the bride's father in Newark, N. J. The presents were numerous and valuable.

The Lancaster Watch Company have introduced into their movements a device for rendering them proof against dust and dampness, regardless of what case they may be placed in. It is the movement that is thus protected, and not the case. It is specially commended to railroad men and to those following industrial pursuits.

Mr. and Mrs. A. K. Sloan have recently made a southern tour, visiting Old Point Comfort, Jacksonville, and other places of interest in the South. They returned by steamer from Charleston, and Mr. Sloan was immediately compelled to "seek the seclusion the cabin grants," on account of a little misunderstanding with his stomach.

France is to have another sale of her crown jewels, by order of the present Government. The sale is to take place early in April. Among the many gems that will be offered for sale is the celebrated Regent diamond, bought by Philip of Orleans from William Pitt, Governor of Madras. The price paid for this gem was 3,375,000 francs.

W. F. & John Barnes, of Rockford, makers of lathes, etc., for watchmakers and jewelers, have received a letter from a customer in Siam, complimenting them on the excellence of one of their machines, the first of its kind ever used in that country. The letter is written in the native language, and, having been reproduced, makes an attractive circular.

S. Howard Monell, who has for the last five years held a responsible position in the house of Wheeler, Parsons & Hayes, has been admitted as a partner in the firm. He is a young man of energy, perseverance and ability, and has a thorough knowledge of the business. His advancement is well deserved, and reflects credit upon the senior members of the firm.

The statement recently made by the *Commercial Traveler* to the effect that the tax of \$200 on travelers in Washington City had been abrogated by Act of Congress, and that, consequently, Washington was a free city, was altogether too previous. A bill to that effect was introduced, but it failed to become a law, thanks to the incompetency of our sapient statesmen.

R. Henrich has just introduced a patent adjustable finger ring, which is not only ingenious but practicable. These rings are made in three sizes, and each ring can be adjusted to two sizes. A portion of the ornamentation of the setting contains an ornamental set screw which can be loosened and the loop contracted or expanded to suit. This device overcomes a constant difficulty encountered in fitting customers with a particular ring that may take their fancy but which does not fit them. The device is not noticeable except as a portion of an attractive setting.

An English genius has lately brought out an India rubber watch case protector, which is a rubber disc fitting over the case, leaving an opening through which the dial can be seen. It is a sort of rubber overcoat, and will, no doubt, serve a variety of purposes. It will keep the watch warm in cold weather, and in the hot season will prevent perspiration getting into it, and will also serve to keep the case from getting fly blown. Now if this genius will only get up an attachment for a watch that combines a boot-jack and a corkscrew, he will "supply a long-felt want."

Messrs. J. M. Chandler & Co., of Cleveland, recently introduced a patented bracelet, representing chain work, but made from a solid piece. By judicious advertising, and because of its merits, it soon achieved a wide popularity. Of course, it was too good a thing not to be pirated, and imitations have been put upon the market by persons who do not recognize the rights of property in patents. Mr. Chandler proposes to proceed legally against all infringers, and leave the courts to determine whether a patent conveys any rights that others are bound to respect. The probability is that the infringers will wish they had not been quite so expeditious in appropriating the work of another.

Some remarkable pearls lately found near La Paz, Lower California, have excited much interest. Three such extraordinary events have taken place during the past month. Probably the largest pearl on record, weighing seventy-five karats, was found toward the close of December. The fisherman sold it on the spot for \$14,000, which, however, was an insignificant sum compared with its real value. Now comes the announcement that one of the fishermen employed has just discovered a finely tinted and perfectly formed pearl weighing forty-seven karats, and valued on the spot at \$5,000, while yet another pearl was found at the same time, smaller than the former, but of a perfect shade, weighing forty karats, and valued at \$3,000.

Gilbert T. Woglom, President of the Jewelers' League, who has been ill for some time, has, by the advice of his physicians, taken a vacation, and is now sojourning at Old Point Comfort. Mr. Woglom has been a hard worker in his business, and also devoted to the interests of the League, not only giving his personal attention to its affairs in this city, but visiting Albany for the purpose of influencing legislation in the interests of mutual benefit societies. It was largely through his efforts and tact that the bill now pending was agreed upon by the representatives of mutual benefit societies, and will probably become a law. The affairs of the League will be managed by the able Vice-Presidents and Executive Committee during his absence.

Cards are dainty accessories indispensable to the science of sociality. In almost every form of social and business life cards are interchanged. Wedding cards are square, made from an engraved plate, and are inclosed in a double envelope, with a smaller card bearing the maiden name of the lady. When invitations are issued for the celebration of the five-year wedding anniversary, the cards are printed on wood. Ten years married, the cards are engraved on paper closely imitating tin. Fifteen years married, the cards are beautifully crystalized. Silver bordered cards when the silver wedding is celebrated, twenty-five years married. Fifty years married, cards with gold border and letters of gold. Seventy-five years married, diamond wedding, cards sprinkled with diamond dust. Pure script is used on invitation cards for full dress receptions. A card with a turn-down corner is intended to signify a call upon the entire family. Dinner cards are very odd; the designs vary considerably, in fact, all sorts of conceits are brought into use, from the comical in art finish to the exquisitely picturesque.

The etymology of the word "bort" is not difficult to find. It is doubtless derived from the Dutch substantive *boor*, signifying piercer, borer, etc. Holland has long enjoyed almost a monopoly of the art of cutting and polishing diamonds and other very hard precious stones, and Amsterdam is still an important center of that industry. No substance will cut a diamond but a diamond itself, and for that purpose diamond dust is employed by lapidaries. In cutting a diamond every particle of the dust is carefully collected, to be afterward again used, but the chief supply of this dust is obtained by crushing to powder inferior diamonds, splinters and fragments of diamonds, and black or anthracite diamonds, (sometimes called *carbonado*) all of which are collectively known in the trade as *bort*. Scarcely any English dictionary or encyclopedia contains the word, which has long been in common use among diamond dealers and lapidaries to designate the inferior stones and fragments I have named. *Bort* is also much employed in rock-boring drills and for piercing holes in rubies and diamonds used in watchmaking. The price of *bort* varies, according to quality, from 30s. to 50s. a karat.

There seems to be a necessity that the trade should adopt some standard of measurement for bracelets. There are numerous bracelet gauges in use, each one claiming to be the best, but they are all made on different measurements, so that when a dealer sends for bracelets of a certain size, the trade does not know what to send him. A standard gauge that all should recognize as such would greatly simplify the filling of orders.

A. H. Fisher, of Springfield, who recently failed, has issued a statement to his creditors which is not a pleasant document for them to contemplate. According to this, his liabilities aggregate \$83,000, and his assets \$75,627, some of which are of questionable value. His offer of forty cents on the dollar is not regarded as satisfactory. In view of statements alleged to have been made by him when buying goods just previous to his failure, his creditors are sanguine of realizing more than his offer contemplates.

A few weeks since the jewelry store of J. C. Klalolt, of Springfield, Ill., was robbed by burglars of goods valued at \$10,000. Mr. Klalolt immediately wrote to his eastern creditors notifying them of the fact, and saying that while he did not want to compromise his indebtedness or ask for an extension, he would request them to exercise what forbearance they could under the circumstances. He further said that if any creditors felt that he was going to lose his claim, he was at liberty to draw on him at sight, and his draft would be honored. A short time afterward four boys were playing in an old graveyard at Springfield when they found a small gold locket. An investigation was instituted, when two satchels filled with the jewelry stolen from Mr. Klalolt were found in an unused sarcophagus. Mr. Klalolt identified his property and it was restored to him. The trade will rejoice that one who acted so honorably in the face of so great a loss should be rewarded in the end by the restoration of his property.

Just as we go to press, an effort is being made in the trade to form an association for the protection of retail the dealers, as suggested in an editorial printed in other columns of this issue. It is intended, if possible, to surround retail dealers with the same degree of protection against robbers and thieves that is now extended by the Protective Union to travelers in the trade. At a meeting of prominent jewelers held a day or two since, a special committee was selected to prepare a plan of organization, and by the time our next number is ready, it is probable the association will be in full working order. This movement will commend itself to every responsible retail dealer in the country, for in the case of a robbery being perpetrated, the cost of bringing the culprits to justice will not fall entirely upon the victim of the robbery, but will be shared by the trade in general. We shall be pleased to receive the views of dealers on this subject, and any suggestions that are calculated to increase the efficiency of the proposed association.

Carl Gullberg, a jeweler, doing business on Montgomery street, Jersey City, is a man who evidently knows a thief when he sees him. A young man recently entered his store and selected three watches and two chains, valued at \$268, and asked that the selected goods be sent to him at 155 Lexington avenue. Mr. Gullberg agreed to deliver the goods, and, in company with his son, started for the address given by the guileless young man, halting on the way to secure the services of two detectives. Arriving at the house the jeweler was met by the sharper, who examined the goods critically, saying that he wished to show them to his uncle down-stairs, darted out of the room and rushed into the street, and was caught by one of the detectives lying in wait for him. The youth was landed in the Jefferson Market Police Court, and held in \$1,500 bail. If all storekeepers were to act with the wisdom and cuteness of Mr. Gullberg before delivering goods to suspicious parties, there would be fewer cases of artistic swindling.

The firm of M. Eisenstadt & Co., of St. Louis, who failed some time ago, have presented through their attorneys what purports to be a statement of their assets and liabilities, which is remarkable for the extent to which the latter exceeds the former. The liabilities are given at \$122,865, and the available assets at \$37,738, with additional outstanding accounts of problematical value amounting to \$24,277. There are some real estate transactions involved, the peculiarities of which would puzzle a Philadelphia lawyer to unravel. This failure is of a similar character to many others that have occurred in the trade, and the outcome will probably be the same—the creditors will together talk over the matter, there will be some growling, and then some one will move that the offer of the firm be accepted, which will be adopted unanimously—then adjournment, and every man look out for himself the best he can. If Mr. Jacobs, a member of the firm, could be induced to come to New York, he might shed some light on affairs that now seem to be suffering from an eclipse.



VOLUME XIV.

NEW YORK, MAY, 1883.

No. 4.

THE JEWELERS' CIRCULAR AND HOROLOGICAL REVIEW

*The recognized organ of the Trade, and the official representative of the
Jewelers' League.*

A Monthly Journal devoted to the interests of Watchmakers, Jewelers, Silver-
smiths, Electro-plate Manufacturers, and those engaged in the
kindred branches of art industry.

SUBSCRIPTION:

To All Parts of the United States and Canada,
\$2.00 Per Annum; Postage paid.

To Great Britain, France, Switzerland, Germany, the West Indies, Mexico, the
Republics of South America, and Australia, \$3.00 per annum. Postage paid.

*All communications should be addressed to D. H. HOPKINSON, 42 Nassau
Street, New York. Advertising rates made known on application.*

Retail Dealers and Outsiders.

THAT THE jewelry business is rapidly seeking other channels than those afforded by retail dealers for meeting the requirements of buyers is a fact that has long been apparent. It is useless to deny it or to attempt to close our eyes to it. On the contrary, the best thing to do is to recognize the existing condition of affairs, and cast about for a remedy. What the legitimate trade calls "outside" dealers now offer the strongest competition that retail dealers are called upon to meet. These outsiders are dry goods merchants, gent's furnishing dealers, stationers, dealers in notions, druggists, etc., who have learned that a line of jewelry adds to the attractiveness of their stock, and, if carefully selected, sells readily, enabling them to turn their money over rapidly. As these outsiders buy for cash, or on short time, they get every advantage in buying that the regular dealer does, and, as they do not depend upon sales of jewelry for their profit, they cut prices and undersell the regular dealers. It is but recently that outside dealers have become formidable competitors for the retail trade; formerly they dealt only in the cheapest kind of imitation goods, and were not looked upon as rivals in the jewelry business; but, as they found the cheap goods attracted customers, they became buyers of better grades of goods, and many of them now handle the same goods precisely that the retailers do, buying of the same houses and receiving equal advantages. We recently saw, in a notion store in this city, an excellent line of fourteen karat jewelry and an elegant display of plated ware and clocks, some of the latter worth as high as \$300. In the same store was an endless variety of goods, embracing the products of a hundred different industries. There are any number of dry goods stores in this city that carry full stocks of jewelry—in fact they are regular bazaars, where buyers can find pretty much every article they require. It has been the aim of our merchants to diversify their stocks as much as possible, to make a small profit on everything, and to turn their money over as often as possible. A. T. Stewart was the first to

undertake to carry all lines of goods in one stock, and his success has induced others in every city in the country to follow his example, till, to-day, mixed stocks are the rule rather than the exception. The proprietors of such stores argue that variety attracts buyers, and one thing helps to sell another. As success has attended the efforts of nearly all who have followed this plan, it is not surprising that outside competition has become so formidable to retail dealers who adhere to the old plan. But retail jewelers are not the only ones who have suffered from this mixed stock business; it is but a few years since there was a howl of indignation because A. T. Stewart, it was alleged, was ruining the business of hundreds of small dealers in all varieties of goods by monopolizing the business. But the public seemed to relish the plan, and rushed to Stewart's in spite of the protests of the small dealers, and continues to throng the establishments of those merchants who carry mixed stocks. As it is the public, after all, that must be catered to, its whims must be humored and its wishes served. It is unfortunate for retail dealers that this outside competition not only exists but is growing rapidly; he who shuts his eyes to the fact is blind to his own interests. Not only in large cities does this competition exist, but it is spreading to the smaller places, and travelers for New York houses report that they find outsiders selling jewelry in nearly every place they visit. As an illustration: In a western village a retail jeweler was located, conducting his business in the regulation conservative manner, selling, perhaps, \$1,000 worth of goods a year, and eking out a living by repairing watches, clocks, etc. He was content to plod along in this manner, lacking the energy to extend his trade. About four years ago there located in that town a young, active, pushing stationer, who included in his stock notions of all kinds and some jewelry. He was a man of energy, advertised liberally, and lost no opportunity for pushing trade. Having good business ideas he paid his bills promptly and earned the confidence of those of whom he bought his goods. Travelers for jewelry houses found him selling goods in their line, and, as his recommendations were good, they sold to him as to a regular dealer. The result was that he captured the trade of the slow plodding dealer, who could do nothing but growl at the jobbers who sold to his competitor. Now, the live, active stationer has added a watchmaker to his establishment, while his sales of jewelry amount to \$10,000 or \$12,000 a year. The question arises, which one of these men shall the trade recognize as the legitimate dealer to sell to? The one whose sales amount to \$1,000 a year, or the one who sells \$10,000 worth of goods? Manufacturers and jobbers will have no difficulty in answering the question, for they will certainly sell to the most liberal buyer, in spite of the protests of the legitimate dealer.

This question is one simply of supply and demand, and no amount of sentiment can stem the current of its insatiable requirements. The public creates the demand and indicates the methods by which it will be supplied. The methods of to-day are not those of a hundred years ago. Our unequalled facilities for travel have brought every little hamlet in the country within a day's ride at most of some

one of the great commercial centers, and there are few persons who do not visit the large cities once or twice a year at least. In those great marts of trade their opportunities for buying are superior to those offered in the smaller places, and, unless the retail dealers in such places are alive to the progressive spirit of the age, they will find their trade straggling off to the great trade centers, where mixed stocks prevail in obedience to the demands of the public. How are the retail dealers to meet this growing outside competition? Certainly not by folding their arms and growling at the manufacturers and jobbers who sell to them. It is the business of these to sell goods, and they will sell to whoever has the means to buy, be he a regular retail jeweler or a hardware merchant. Cash will take the goods every time regardless of sentiment. In fact there is no sentiment in business—there cash is king. We are told by prominent houses in the trade that, as a rule, the outsiders are better pay than the regular dealers; they do not ask for so long credits, and pay promptly when their paper matures. It is natural, therefore, that manufacturers and jobbers should sell to them; their goods are made for the express purpose of turning into cash, and the sooner this is done the more satisfactory and profitable it is to them. There is too much human nature among them to expect them to sacrifice their profits at the demand of the retail dealers. It is a fact not generally known to the trade that there are more outsiders selling jewelry at present than there are regular dealers, and that they dispose of a greater amount of goods in the course of the year. They buy goods for cash or on thirty days' time at furthest, while regular dealers expect from four to twelve months' credit. Manufacturers and jobbers cannot ignore these facts, or reasonably be expected to forego the advantages offered by them. As the number of outsiders is increasing every year, the eastern manufacturers will cater more and more every year to their wants. This class of manufacturers may continue to endeavor to mislead the retail dealers by denying their sales to outsiders, but the fact that outsiders have their goods is proof positive of their duplicity. We are by no means justifying the manufacturers and jobbers in selling to outsiders at the expense of the retail trade; our position in this respect has been too explicitly defined to be misconstrued; we are simply discussing the facts as they exist, and as they will continue to exist. State associations and individual dealers may protest against this recognition of outsiders by manufacturers and jobbers, they may publish black lists and refuse to buy of them, but their efforts will be as fruitless as were those of Mrs. Partington when she undertook to sweep back the ocean with her broom. Trade is governed by the laws of supply and demand, and these are immutable. The remedy for the evil lies with individual dealers and not with state associations, although the latter can render valuable aid when directed by intelligence and practical good sense. The retail dealers must be as enterprising as their neighbors, and meet competition with competition. If an outsider mixes jewelry with his stock and is capturing trade, the retail dealer should carry the war into Africa, and introduce a diversified stock. There are many things that may appropriately be handled by jewelers, and their profits thereby increased. A good line of perfumery or of musical instruments is attractive, while a stock of gent's furnishing goods will aid them in selling jewelry quite as much as it does the dealer who makes a specialty of gent's goods and jewelry. In many jewelry establishments in the east a good trade is done in stationery, in Christmas, Easter and birthday cards, as well as in more elaborate works of art, oil paintings, statuettes, etc. Why should it not become the rule for retail dealers to make their stores more attractive by goods of this character, and by introducing notions of all kinds? As engraving is a kindred branch of the business, let them go into the fancy stationery line, get up wedding and visiting cards, monograms, illuminated and fancy printing of various kinds. Let them diversify their business and give the public what it demands, whether it be jewelry, neckties, perfumery, or books and stationery. We know an instance where a dealer with literary tastes improved his trade greatly by keeping up a circulating library, the

additional labor imposed being cheerfully assumed by his daughter. "Fight the devil with fire" is an old axiom, and is applicable here. If the public demands mixed stocks of goods in the same establishment, provide the mixed stock, and make it as attractive as possible. If there did not exist such a demand there could be no complaint of outsiders, for these are but caterers to the public and certainly would not carry a mixed stock unless there was a profit in so doing. Retail dealers themselves help to create this demand, for if one wants a pair of boots he will not hesitate to go to a dry goods store for them instead of the shoemakers, if he can save a quarter by so doing, and why should not the shoemaker buy his jewelry on the same principle? To overcome this growing competition from the outside, retail dealers must prepare to meet it with more spirited competition. The first step towards doing this is to place their business as nearly as possible on a cash basis, for such credit as they must have ask but short time, meet their paper promptly, and thus be in a position to avail themselves of every advantage in buying that the market offers. They must make up their minds that the retail trade in jewelry does not belong to them by any divine right, but must be shared with any enterprising man who chooses to engage in it. Manufacturers and jobbers cannot, as we have shown, ignore this outside trade, and the retailers must, consequently, make up their minds to encounter it. To do so successfully they must be wide awake, enterprising and pushing. They are capable of holding their own against any other class of business men in existence if they will but learn to rely upon themselves, and not expect the manufacturers and jobbers to bolster them up in maintaining a monopoly of the sales of jewelry.

THE CIRCULAR has been and is the steadfast friend of the retail dealers, and it is because it is their friend that we speak plainly on this subject. We are in a position to know the sentiments of a majority of the manufacturing and jobbing houses, and we know that it is impossible for them to put aside their trade with outsiders; indeed, as we have shown, it has got to that point where it is difficult to distinguish frequently between the regular dealer and the outsider. Their business cards and advertisements read like those of the regular dealers, and they show a knowledge of the business that will enable them to pass as such. But whether outsiders are known to be such or not, they can and will get all the goods they want at trade prices if they have the money to buy with. This is inevitable, and, however much we might wish it otherwise, it is a stern fact which the retailers must face, each for himself. It is useless for them to attempt to proscribe those who sell to outsiders, for they cannot prevail against the inevitable; the true remedy is to be ready to meet such competition as outsiders may inspire with such a degree of energy and enterprise as characterizes the business of their rivals.

POLITENESS is one of the cheapest things a man can deal in. It costs nothing to be pleasant and cordial, or to extend agreeable courtesies to our fellow pilgrims in this world of work and worry. It is just as easy to greet a person with a pleasant "good morning" and a smile as with a surly grunt and a scowling countenance, and it is certainly much more agreeable to him who receives it. Politeness and courtesy are twice blessed, like charity, blessing him who receives and him who gives, for no man can be pleasant and cordial with others and surly and cross with himself. Therefore it pays to be good natured, cordial and polite. But there are men in the trade who seem to think the reverse of this is true, and take pleasure in cultivating an abrupt, coarse, cross manner, and displaying it on all possible occasions. Travelers for jewelry houses often meet with great discourtesy at the hands of the dealers whom they are striving to serve. There are several kinds of men who thus cultivate their ingrain ugliness till it becomes second nature to them, and they find it almost impossible to be civil to anyone. They pass for men, but act more like certain kinds of animals—give them bristles and there would be no difficulty in classifying them. A traveler enters the store of one of these gruff, bristly animals, and presents the card of

his employers. He is met with a rebuff at once. "Don't want anything—am bored to death with drummers—hate the sight of them," etc. He will not even look at samples, and the traveler takes his departure in disgust. There is another class, comprised of purse-proud upstarts, who, having made a little money, think all the world should be subservient to them. Men of this stamp delight in keeping a traveler dancing attendance upon them. They know the traveler is expected to call upon them, and would be loth to leave town without an interview, so simply to gratify their pure cussedness, they invent excuses to make him possibly miss his railroad connections and so lose a whole day. If these men knew what a reputation they get in the trade by their discourtesy, they would reform their manners. Travelers report to their employers the kind of customers they have to deal with, and many a buyer has been treated with coldness on his visits east when he could not account for it. The secret of it lay in a previous discourtesy to traveling men. Discourtesy not only leads to a cool reception at the home offices, but injures a man's credit with those of whom he has to ask favors. Travelers give the man with bristles a generally bad reputation, speak of him as a cross, surly brute, and give such a report of him that the word passes among their fellow travelers that he is a man to avoid. Give a dog a bad name and it will stick to him, and he will be charged with sins of which he is not guilty, so the solvency of these gruff and grum dealers falls under suspicion, as the result of the severe censure cast upon his objectionable personal characteristics. It is true that there are a lot of drummers in the business who are a nuisance to the dealers and ought to be suppressed, but they are no more to be compared to respectable commercial travelers than the men they represent to the solid responsible houses in the trade. When a traveler presents to a retail dealer the card of a well-known and responsible house, he is entitled to be treated as a gentleman; he is the representative of the firm that employs him, and any indignity shown him is sure to be resented by the firm in some way. The traveler is trying his best to accommodate the patrons of the firm, and to this end brings to their doors samples of the latest styles of goods and of the popular novelties, and is prepared to take their orders at the same prices they would have to pay if they came to New York to buy them. They are the means of saving the retail dealers many dollars of expense, and as a matter of self interest the dealers should treat them with courtesy. It does not take long to examine the samples a traveler carries, and to look at them does not constitute an obligation to buy. No dealer of intelligence can run through the sample trunk of a traveler without getting ideas that are valuable to him, and it ought to be a pleasure to him to do so. Fortunately, most dealers so regard it, and the gruff and grum sort are few in number. If they consulted their own interests these few would change their tactics, and accord to all respectable travelers such courtesies as they would like to receive under similar circumstances. It costs nothing to be polite at all times, and genial, pleasant manners are worth money to any man.

THE RETAIL dealers in this city are complaining loudly of eastern manufacturers selling their plated goods to the outsiders, and they talk of organizing an association, the members of which are to bind themselves not to buy any goods whatever of those manufacturers. The question is, whose goods will they buy? Where will they get the necessary stock with which to maintain themselves as retail dealers? There are a large number of popular dry goods, notions and fancy goods houses in this city that make a business of dealing extensively in the cheaper grades of jewelry, while a few of them handle the more costly kinds. They are large buyers for cash, and they are the middlemen who sell largely to outsiders all over the country. We could name fifteen or twenty dealers in New York and Brooklyn who handle more cheap jewelry than all the retail dealers within a hundred miles of the city. They can buy whatever goods they want, for no manufacturer will refuse his goods when the cash is counted out for them, and it would be difficult to find

one who does not directly or indirectly seek their trade. Many of them, we know, deny that they sell to outsiders, but outsiders get their goods all the same. The representative of an eastern house is frequently asked by a retailer if he sells to Macy or Ridley, or any of these outside dealers, and his invariable response is that he does not, but the retailer will find the same goods in these same stores, and selling at a less price than he can afford to retail them. As an instance: The representative of an eastern house called on a jobber recently and showed him something "entirely new and attractive," and that promised to have a good sale. He was asked definitely if Macy had the goods, and was told that he was the first person who had seen them. Thereupon he bought quite liberally, and at once hurried up to Macy's, hoping to forestall the manufacturer in selling to that house. He produced his sample, and was informed that they had had the goods for a week, and had found a liberal demand for them. He also ascertained that by paying cash for them Macy had purchased the goods for fifty cents a dozen less than he had paid. While this was a little sharp practice on the part of both manufacturer and jobber, it serves to illustrate the fact that the outside dealers who pay cash can get all the goods they want. Their orders are more liberal than those of the retail dealers. A buyer for one of these popular bazaars goes to a jobber, looks over his samples, orders a dozen of this, a dozen of that, a gross of these and a bountiful supply of everything that he thinks will sell, and concludes by saying, "send your bill and get your check." A retail dealer comes to the jobber, looks over his samples, orders half a dozen of one thing, a quarter of a dozen of another, a twelfth of a dozen of something else, and wants four months or more in which to pay for them. We confess that we do not see, under the circumstances, how the retail dealers are going to prevent manufacturers catering to this outside trade, when it is through outsiders that they dispose of the larger portion of their product. We have appealed to them to protect the retail trade, but the inevitable laws of commerce are against their doing so. It is their business to manufacture goods and to dispose of them they must avail themselves of every opportunity and every avenue that is open to them. No combination of retail dealers will prevent their doing this; on the contrary, if they attempt to proscribe the manufacturers, these will do all in their power to extend trade with outsiders, and to introduce more competition into the business. These dry goods and fancy goods bazaars have, it must be admitted, largely diverted the current of trade in the cheap grades of jewelry, and the sales of the legitimate retailers are greatly diminished in consequence. We are free to say that we do not see wherein the remedy lies, but state the facts, and commend them to the careful consideration of all who are interested in the result. We have no remedy to offer, except the suggestions contained in another article in this issue of THE CIRCULAR. Of one thing we are quite certain, and that is that any combination to taboo those who sell to outsiders, so far from curing the evil, will only tend to increase it, and to multiply the number of outside buyers.

THERE are some manufacturers who get frightened very easily, and if trade slacks up a little at any time they join the ranks of the croakers and fill the air with predictions of hard times to come. They do not appear to watch the conditions that influence trade to be brisk or dull, but if there comes a temporary lull in the demand for goods they become demoralized and incapable of reasoning from cause to effect. It is this class of manufacturers that, at the first symptom of dullness, seek to create an artificial demand for their goods by cutting prices. They are so afraid of being caught with too many goods on their hands that they proceed to cut their own prices, thus injuring themselves and their brother manufacturers without conferring any appreciable benefits on the retail dealers. Indeed, they are more apt to permanently injure the retail trade, by tempting dealers to an unwholesome competition at an unseasonable time, or by overstocking them. When prices are reduced to stimulate a dull trade, they cannot be restored when trade improves, and

the manufacturer finds that he has seriously curtailed his profits. In the jewelry business, where skilled labor is so largely employed to give value to the goods, a reduction of prices is especially injurious, as it involves workmen alike with the manufacturers, for when prices fall the manufacturer begins to curtail expenses, and retrenchment at the factory is one of the first of the so-called "reforms" to which he turns attention. This periodical weakening on the part of a few manufacturers is as unwise as it is demoralizing, and wholly unnecessary. If trade is dull when a brisk demand is anticipated, the activity is merely delayed, not lost. It is only in times of great financial revolutions that trade is so broken down that its requirements cannot be anticipated, and nothing of the kind has occurred in several years, nor are there any indications that it is likely to occur in years to come. The jewelry trade has long counted upon increased activity in the spring and fall, yet there have been many seasons when the spring or fall trade has apparently been exceedingly dull. But such dullness did not decrease sales, it simply strung them out over a longer period, and manufacturers found, at the end of the year, that their sales had been fully as great as in those seasons when the spring and fall rush was more pronounced. Production should always be governed by demand; if the people want goods they will buy them, but overstocking retail dealers will not force them to buy, nor will they buy what they don't want simply because it has been reduced in price. Ordinarily the demand for a class of goods grows out of the necessities of the people, but with jewelry it is different. Jewelry is more in the nature of a luxury, and the demand for it grows out of the ability of the people to purchase it. When the country is prosperous, money plenty and easily earned, it is freely spent to gratify the tastes as well as the necessities of humanity; but in hard times no cutting of prices will induce the people to buy. The only sensible course for manufacturers to pursue is to fix a reasonable price upon their goods and maintain it at all hazards and at all seasons. If they sell to Jones at one price and to Johnson at another, they injure their own business and set Jones and Johnson by the ears. While there has not been as much activity in the trade this spring as was hoped for, there has, nevertheless, been quite as good a demand as was anticipated by those who carefully noted during the fall and winter the signs of the times. In spite of the croakers and the undercutters, we venture to predict that when the trade closes its books for the year it will find that the volume of business has been as great as it was last year, when no one had any cause to complain.

IT IS commonly remarked that electricity is in its infancy, or, rather, that our present knowledge of its application is elementary. The telegraph, telephone, electric light, etc., have proved to be great blessings to the people, and the *Times* gravely informs us that learned scientists have recently devised electric rat traps, and appliances to be attached to back fences for the instantaneous electric destruction of operatic cats while in the midst of their midnight concerts. One noted expert has turned his attention to the application of electricity to domestic purposes, and proposes to make this subtle fluid usurp the places of those domestic helps we import so freely from Erin's Green Isle. He has already so far perfected his apparatus that it will broil steaks, boil potatoes and wash dishes, but has not yet achieved that perfection in crockery smashing for which the present servant is so justly celebrated. While inventors are thus striving to compel electricity to cater to the necessities and comforts of the human family, the jewelry trade has not been neglected. Prof. Jobberwitz is now at work on a machine that is intended to be of great benefit to retail dealers. It is designed to protect them from the importunities of Providence and Attleboro drummers. By bringing a wire in connection with the drummer and touching a button, the machine quietly takes hold of him by the most available parts and gently deposits him outside the door, thereby saving the dealer considerable exertion and much profanity. Another electrical apparatus, the invention of Dr. Kremlinstein, F. R. S., was designed to

induce all sellers of jewelry to tell the truth, but it worked with such accuracy that it was seen its use would utterly prohibit the sales of jewelry, and so his patents were bought up by interested parties to prevent the introduction of the machine. Prof. Sneezowski, a distinguished Polish electrician, has perfected an apparatus for distinguishing debased metal from the genuine. It is so contrived that it will designate the quality of each article in karats, and if a number of articles of different grades be brought in contact with it, it separates them into piles, according to quality, placing the 12, 14, 16 and 18-karat goods each by themselves. Anything below 12 karats is utterly annihilated. The Professor recently experimented with some cheap Providence jewelry; the wires were brought in contact with each piece, and the battery was turned on; there was a puff of smoke, a terrible odor, and that which had been called jewelry had entirely disappeared; there wasn't gold enough in it to leave even the color of a vestige behind. It is reported that an expert electrician has hopes of perfecting a machine that will compel debtors to pay their obligations at maturity, and creditors not to sell on more than thirty days' time, but this is regarded as an impossibility. There is danger that the application of electricity to business purposes may be carried too far; as intimated, there seems to be a disposition to compel honesty in the trade, and such an attempt should be frowned down; the jewelry business is altogether too useful to mankind to be destroyed in any such summary manner. If this thing goes on we shall have to appeal to Congress to put a safety valve on electric inventors so as to permit them to blow off harmlessly after they have steamed up to a certain point. The old established customs of commerce must not be set aside by such dangerous innovations as we have indicated.

THE DISTRUST or apprehension in business circles, which some time ago was felt rather than expressed, having, owing to various causes, entirely passed away, a marked increase of confidence and of activity is expected. With the adjournment of Congress and the advent of more genial weather, business cannot but take a fresh start. Even now, however, spite of many drawbacks, there is but little cause for complaint. At the Northwest, notwithstanding the floods, the situation is the reverse of discouraging.

The general jobbing trade of Chicago is quite as good as usual, and in several branches exhibits improvement. Advices from the country beyond Chicago indicate that the deliveries of corn are quite large in Nebraska and parts of Kansas and Western Iowa. Farmers are carrying it to country stations very freely, and receipts at leading points may be expected to show a large increase now that fine weather has fairly set in.

General business throughout the country is fully as active, though probably less profitable, than it was a year ago. This we consider a healthy sign and an indication of continued prosperity. It would be impossible to expect a continuance of the immense transactions and large profits of the last few years without occasional interruptions, which necessarily are felt in certain branches more than others. Still, it should not be overlooked that these influences are for the most part of a temporary character and must speedily yield to those of a more favorable sort.

1882 was a year of unbounded production in almost every department of industrial activity. The increase of the population by immigration was beyond all precedent. The late autumnal season added greatly to the value of the flocks and herds scattered over the country. As yet the farming community have realized upon but a small portion of the vast stores with which they last year replenished their granaries, and the exports, which have already climbed to very respectable dimensions, must, necessarily, vastly increase within the next few months. Railroad earnings must grow in proportion, and the whole condition of the commerce of the country promises a large, safe and profitable trade during the balance of the year. Another proof, if any be needed, of the continued prosperity of the country is found in the condition of the savings banks of this State. The resources of these institutions increased nearly thirty million dollars

during last year. This is mostly made up of the savings of the working classes. So large an increase in their bank account indicates a proportionate increase in contentment and well being among a million of laboring men. The savings of the laboring classes in this State are a fair criterion of the savings of the same class throughout the country.

COMPLAINTS come to us regarding a certain class of silverware that is stamped "sterling," but which turned out to be far below that standard. There are certain unscrupulous men in the trade who are glad to get hold of just such goods, the price being gauged by the quality, and to sell them as genuine "sterling" silver goods. But the manufacturer who caters to this trade, even though he may get for the goods all they are worth, must have an elastic conscience, and one that will accept any excuse that will reconcile it to wrong doing. He knows perfectly well that these goods are intended to defraud purchasers, and he is an accessory before the fact, whether the swindle is perpetrated for his profit or that of a third person. We see very little difference between selling debased silverware for genuine silver and debased coin for good money; in the latter case, the one who makes the bogus coin is held to be a criminal, even though he sells his product for the actual value of the metal and labor put upon it, but the manufacturer of debased "sterling" silverware, which is made expressly to deceive, is not liable to any penalties whatever. The man who sells it, however, for "sterling" silver is amenable to the law for misrepresentation and fraud. The excuse made by manufacturers is that dealers want these debased goods for a certain trade, and to meet certain competition with, and they make them under the plea that if they do not some one else will—the same plea that the rum-seller uses to excuse his business of making drunkards. When a manufacturer receives an order for debased goods that are to bear the stamp of the genuine, he knows full well that a fraud is contemplated, or, if not contemplated, that the goods so made are an incentive to fraud. No excuse will satisfy the conscience of an honorable man that he is justified in putting such goods on the market at any price. Purchasers buy it in good faith and pay "sterling" silver prices for it. When it becomes old or defaced and they attempt to sell it for old silver, they are astonished to find how large a percentage of debased metal it contains. The way to avoid such petty swindles is to deal only with those established houses whose reputations are a guarantee that the goods they sell are precisely what they are represented to be. This is another instance wherein the law we have advocated, providing a penalty for stamping goods above their intrinsic value, would serve as a check upon the unprincipled men in the trade. If goods fraudulently stamped could be seized and confiscated, and used as evidence against the manufacturer and the seller, there would soon be an end to the production of debased goods.

The Jewelers' League.

President—GILBERT F. WOLOGOM.
 First Vice-President—JAMES P. SNOW.
 Second Vice-President—HENRY HAYES.
 Third Vice-President—WILLIAM C. KIM-
 BURN.
 Fourth Vice-President—AUGUST KURTZE-
 BORN.

Secretary and Treasurer.—WILLIAM L.
 SEXTON. Post Office address, Box 3444, New
 York City.
 Executive Committee—ROBERT A. JOHNSON,
 JOHN D. LYON, JOSEPH B. BOWDEN, JAMES
 D. YERRINGTON, SAMUEL W. SEXTON, C. B.
 BISHOP.
 Examining Finance Committee.—CHARLES
 G. LEWIS, C. G. ALFORD, GEORGE R. HOWE.

THE JEWELERS' CIRCULAR is the *exclusive* official paper of the Jewelers' League, and has been selected for the publication of all matters of interest pertaining thereto. Letters or inquiries pertinent to its business or purposes, and which might interest the trade or inquirers, will herein be answered. Address *Jewelers' League, Box 3,444, P. O., New York*, or the office of THE CIRCULAR.

OFFICIAL NEWS OF THE MONTH.

The total membership of the Jeweler's League is now 2,540, being forty more members than was originally contemplated, the restriction as to members having been removed. All members of the jewelry and kindred trades, who can pass the

required examination, are eligible to membership in the League, in accordance with the amendments to the Constitution removing the limitation of numbers. The growth of the League has been steady and substantial rather than forced and rapid, the members preferring to gather into the fold such as would add to its strength rather than weaken it. It has been remarkably favored as regards mortality, there having been but comparatively few deaths, an indication that the members of the jewelry trade are healthy and temperate men, and good subjects to insure. We have received several communications from members inquiring how it is that the Secretary has not sent them notices of assessments for deaths of members. Whether these inquiries exhibit an eager desire on the part of the writers to contribute towards the expense of burying some of their fellow members, or simply a willingness to further the best interests of the League, we will not attempt to say, but can assure all members that the vigilant and obliging Secretary will never miss one of them when more money is required. The benefits already conferred by the League have won for it the confidence and cordial endorsement of the prominent men in the trade, and those who have not yet sought its protection should hasten to send in their names.

The Legislature now in session recently passed an entirely new law relative to benefit societies like the League, the administration of which, by Mr. McCall, the New Superintendent of Insurance, is calculated to be of benefit to all honestly conducted associations of this character. It draws the line between honestly managed benefit societies and those speculative concerns that are run in the interests of adventurers, giving to the former lawful protection, while it subjects the speculative concerns to fair official supervision. The law was passed at the instance of the honest benefit societies, the officers of the League being largely instrumental in perfecting it and influencing its final passage.

Mr. Woglom, President of the League, is still at Old Point Comfort, recuperating his health after his recent severe indisposition. During his absence the Executive Committee has charge of the affairs of the League, and its members exhibit a most commendable alacrity in attending to its requirements.

Our readers will be pained to learn that C. B. Bishop, a member of the Committee, met with serious injuries by the railroad collision that recently occurred near Philadelphia on the Bound Brook road. We are happy to state that he is rapidly recovering, and is expected soon to be able to attend to his duties in connection with the League.

John Frick & Co., members of the League, have just introduced the official badge of the League, made in accordance with the design adopted at the recent meeting. It is a neat, tasteful ornament, without being obtrusive or vulgar, and will, when worn by members, doubtless prove a passport to many pleasant acquaintances.

The following thirty-eight applicants were admitted to membership in Jewelers' League, April 6, 1883:

Chas. D. Shelling, Henry Zimmer, Wm. H. Sutton, John F. Stout, Edwin A. Phelps, Frank T. Ostrom, John J. O'Brien, F. W. C. Nieberg, Henry Muller, Andrew J. Marsch, Henry C. Lyman, Wm. H. Jennings, August Hoffmeister, Henry P. Fletcher, Numa J. Felix, Chas. W. Cooley, Clarence F. Pierce, New York City; Henry H. Snow, Samuel J. Boyce, Boston, Mass.; Harland G. Bacon, Plainville, Mass.; T. Edmund Krumbholz, Chas. Reiss, Albany, N. Y.; Jos. Wiesbauer, Buffalo, N. Y.; Burton H. Wade, Salamanca, N. Y.; Chas. E. Rodgers, Rochester, N. Y.; Geo. S. Garrabrant, Newark, N. J.; Frank A. Miller, Susquehanna, Pa.; Ferdinand Schwarz, Wm. A. Davidson, Cincinnati, Ohio; F. S. Bartholomew, Cleveland, O.; Max F. Doering, Knoxville, Tenn.; Isaiah Keasler, Aurora, Ill.; M. E. Capelle, C. Hornick, Chicago, Ill.; Homer Munson, Mendota, Ill.; David A. Shepherd, Brookfield, Mo.; Adolph Meyer, Omaha, Neb.; John Woltz, Winnepeg, Manitoba.

Forty admitted April 7, 1883:

Gustav Schreitmiller, Clarence I. Rupp, Gustave Hofman, Herman Harrison, William Dane, John W. Cocks, Paul J. Bohme,

New York City; Walter F. Robbins, Skowhegan, Maine; Major A. Stevens, West Fairlee, Vt.; John D. Wyman, St. Albans, Vt.; Geo. C. Rogers, Salem, Mass.; John Pickering, Wm. J. McCarthy, Patrick I. Casey, North Attleboro, Mass.; Chas. W. Oviatt, Albert E. Lyke, Rochester, N. Y.; W. S. L. Frear, Union Springs, N. Y.; Edward F. Anderson, Troy, N. Y.; Ellis P. Earle, Newark, N. J.; John W. Shuler, Harry K. Mitchell, Frank C. Jarden, J. Orne Godwin, Geo. G. Bishop, Wm. Bardsley, Philadelphia, Pa.; John P. Steinmann, West Newton, Pa.; J. H. Baldwin, Troy, Pa.; Theo. Stunz, Baltimore, Md.; Chas. W. Schember, Meridian, Miss.; Aaron Plant, Cincinnati, Ohio; Wm. C. Newman, Steubenville, Ohio; Chas. W. Lucius, Indianapolis Ind.; Frank M. Sprochule, Fred Blauer, Wm. H. Burton, Chicago, Ill.; Reuben S. Patterson, Port Huron, Mich.; Daniel C. Stapleton, Des Moines, Iowa.; Wm. R. Sutherland, Kansas City, Mo.; Jesse Collom, Minneapolis, Minn.; P. K. Wiser, Mankato, Minn.

Total membership, 2,540.

Amount in General Fund, \$3,317.17.

Amount in Benefit Fund, \$4,816.50.

Nine changes of beneficiaries granted; five applicants rejected; thirteen applications referred for investigation.

L. K. Baldwin, M. D., appointed examining surgeon in Philadelphia; office 400 Chestnut street.

Clement B. Bishop appointed a delegate to the Union of Mutual Benefit Societies, in place of Gilbert T. Woglom, resigned on account of sickness.

No applicants accepted from places where there are regular League examiners unless they be examined and recommended by these physicians.

Problems in the Detached Lever Escapement.

BY DETENT.

WE HAVE several excellent works on the detached lever escapement in a perfect and healthy condition, giving detail drawings and describing the action and principles involved when every part is as it should be; this is all right as far as it goes, but does not the trade need something further? Are we not in a somewhat analogous condition to a student of medicine who understands anatomy and physiology, but has studied no books on the diseases to which the human body is subject? Or in other words is it not quite as important for the young watchmaker to know with certainty what is wrong, as to know in a suggestive sense that something is not right? The writer assumes that the reply to this question is too evident to need repeating; as all workmen of experience are aware that in the practical routine of the workshop, it is much more difficult (in many cases) to locate the trouble than to remedy the defect. A case in point to illustrate: An anchor lever was brought to the writer with the history that it would stop in the pocket; hardly ever could it be caught stopped, but would be found an hour or two out of time, but going. I found in the train every wheel with the teeth filed; some workman had fancied there were bad depths somewhere, and, like the schoolmaster, to punish the boy who had done some mischief, and being unable to fasten the guilt on the real offender, decided to flog the whole school. Probably the pedagogue was more fortunate than the workman who attacked the watch—for the master, if he punished *all*, must have included the guilty one—but our workman missed the fault, which lay entirely in the escapement, and was briefly this: the fork was a mere trifle too short on the guard point; this, in conjunction with the depth between the escape wheel and pallets, which was a little shallow, was the cause of the watch stopping.

The philosophy of the trouble was this: Some accident caused the pallet to unlock, and brought the guard point against the roller, stopping the balance; the pieces were so nearly balanced that the parts staid in this position for maybe an hour, or five minutes, when some motion of the body gave a preponderance of power to the balance, and off the watch went again, may be for a week. As soon as the trouble was located, the question arose how to remedy it the quickest and easiest. Two courses were available; first, to set the

escapement a little closer, so that no teeth of the scape wheel could entirely leave the locking face of the pallet jewels, while the guard point rested against the roller; second, to stretch the guard point a trifle.

The writer does not propose in the present paper to describe the method for doing any job, but to prepare the way for the consideration in a practical way of similar defects, and as the article progresses with cuts and descriptions, consider such questions as have bearings on lever escapements, and point out the most expeditious methods of remedying and repairing them. To make the plan of our system of considering some faulty condition of an escapement in the light of a problem, and analyzing it, bringing all the factors and conditions involved into a process of mental relation, so as to see the end—the *ultimate end*, of any change we propose to make. We will suppose, to illustrate, that we have an English lever (ratchet tooth) escapement in hand; the real fault lies in the scape wheel being too small, but in the problem this does not appear. We are not told the scape wheel is too small—we accept certain conditions and ultimately arrive at the correct solution, *i. e.*, scape wheel too small. As soon as this is *definitely* settled, we can go at our job safely and remedy it. But without a correct understanding of the problem we might attempt to remedy the trouble and involve ourselves in others. We will next suppose our scape wheel and pallets are just adapted for each other, but out of depth—too far apart. Now the symptoms are very much alike in both cases, and still what would cure one would only sicken the other. We will give one more example and then review the idea of problems. Suppose we have another case of ratchet tooth lever escapement, in which the roller is too small and the fork proportionally too long, as far as the pallets and scape wheel are concerned, they are all right; and suppose in addition to the roller being too small, the depth between the escape wheel and pallets were a trifle too close. All these questions to the experienced and practical man can be solved mentally. But to the beginner, after understanding the principles of a correct escapement thoroughly, the next step is to understand the incorrect, for my word for it there is and can be no combination of difficulties and imperfections which do not exist in some escapement. Very frequently errors can be surmounted, or, if I may be allowed the term, *evaded*, and a compromise effected by making one fault correct to some extent another. It is the writer's idea after taking one form (say ratchet tooth) of lever escapement, and describing it and illustrating it with cuts to show the correct form and condition, to then apply the system of problems and follow the effects of such errors as have been mentioned above, and see how they modify and affect the whole escapement. The manner of drawing an escapement will be somewhat varied from the course pursued by other writers, and the benefit to be derived from the change is, it is hoped, will be to make the proportions used more vividly impressed on the minds of the pupil. The writer proposes to do this by keeping the relative proportions constantly in view, and in this way enable the mind to judge instantly as regards the correctness of the escapement in hand. The inference is not to be drawn from these remarks that the manner of drawing a lever escapement is to be improved upon, by no means, but to bring forward and impress certain standards of the ratio of one part to another.

To illustrate: A certain size of scape wheel requires a relative size of pallets to get a correct action, *and it is as well to assume the radius of the scape wheel as the basis of our calculations, as to assume the diameter of any certain extent.* Now as the radius of any circle is exactly 60 degrees, we have a standard of measurement both as regards linear extent and degrees of action. And it is by assuming the scape wheel radius as a basis that the writer hopes in the outset to establish an ideal standard to which the mind will constantly refer in judging the correctness of construction in any escapement. And after this ideal condition of perfect construction is fixed on the mind, then by these supposed problems of the effects of various imperfections to so discipline the workman's mind that he will instantly detect the fault or faults, and also be instructed how to go practically about the remedy, and effect it quickly and in a workmanlike manner. Some critic may suggest that the radius of the scape wheel is no criterion as regards the length of lever (long or short fork); to such I would beg them to hold their verdict until a further explanation. At any rate they must admit that if we have 10 degrees pallet action and 30 degrees roller action, that we have a relative proportion, which the mind will readily grasp, be the fork long or short.

Electro-Gold and Silver Plate.

BY JOHN W. MILES.

Continued from page 83.

TO THE naked eye the freshly deposited silver presents a beautiful matted appearance, but under the microscope it is found to consist of a multitude of minute crystals with intervals between them, and with facets reflecting the light in every direction. A few drops of bi-sulphate of carbon thrown into the solution will produce what is called "bright plating;" that is, the silver, instead of being thrown down in a matted form, will be deposited as bright as though polished, thus saving a vast amount of labor in burnishing, etc. As, however, the processes of burnishing and finishing tends to harden the silver, bright plating is rarely used on reliable ware.

Until within thirteen years the electricity used in silver plating was generated entirely by galvanic batteries—two or more cells to each vat of solution—the weight and consequent thickness of the silver deposit being determined, primarily, by weighing the article before and after plating, and thereafter by the time taken in the first operation. In some cases clock dials were fastened immediately over each vat, the movable hands being set to the time plating began and constantly compared with the clock until the time requisite expired. Owing to the fact, however, that the rapidity of disintegration and deposition is in direct ratio to the strength of the electric current, the weakness of the galvanic battery involved the consumption of considerable time. The cells also being inconstant in action, and constantly diminishing in power, the "time" rule was obviously unreliable. It was manifestly in the interest of both the manufacturer and consumer that some quicker and more exact method of plating should be devised.

The attempt to use magneto-electricity for the deposition of metals was made as early as 1868, but with questionable success, owing to the difficulty of obtaining a continuous current. The invention of Wilde's magnetic-electro machine overcame this objection, and by its use a great increase of electrical power was gained which effected a considerable saving of time. Following this came the automatic scale, a diminutive illustration of which is here given in connection with Wilde's machine, fig 1.

The articles to be plated are suspended from the frame *A* in the silver solution. The frame being connected with the negative pole of the magneto-electric machine *B*, and the silver suspended in the solution from the bars *C C C* connected with the positive pole, a circuit is formed for the electricity through the solution. The scale *F* is then balanced to the exact weight of silver to be deposited on the articles. Turning the switch *D* so it will bear on the buttons *E E* completes the circuit and the plating begins. As soon as the articles receive the proper weight of silver the scale beam *F* rises, thus making a separate connection with the electro-magnet *G*, which, springing the switch *D*, breaks the electric current and stops the plating, simultaneously ringing the alarm bell to notify the workman that the articles have received the proper weight of silver and the

work is finished. Notwithstanding the certainty of the automatic scale, the practice of weighing each article before and after plating is still followed in order to "make assurance doubly sure," a matter of vital importance to the consumer, when it is remembered that a "washed," or very slightly plated, article has the same appearance when new as reliable ware. In this, as in metals, the consumer must rely wholly upon the integrity of the makers, since a thin film of silver can be as easily and evenly deposited as heavy plate. For this reason the larger manufacturers have not hesitated to stamp upon their productions their names and trade marks, relying upon the quality of the goods themselves for future sales. As may be expected of every genuine and valuable article—even bank notes—there have been numerous counterfeits of the more celebrated wares placed upon the market by unscrupulous makers, who thus seek to find sales for their unreliable productions under honestly earned reputations. In some cases these parties have transgressed the law and have been promptly suppressed, but in others they have kept just within the law and still solicit with impunity the patronage of the public under names and trade marks as nearly similar to old and established houses as the law will permit. Trade marks in electroplate, therefore, assume an importance of great magnitude, and both

dealers and consumers should, for their own protection, carefully examine them before purchasing. It may also be mentioned here that ware of the finest grade rarely if ever finds its way to the auction room, and buyers who have purchased of the auctioneer articles represented to be "just as good," may soon find that "all's not gold that glitters."

No improvement has been made upon the automatic scale, but with the general advance in electrical science a more satisfactory method of generating the fluid has been devised in the Mather

dynamo-electric machine—a recent invention of great excellence and value. (Fig. 2.)

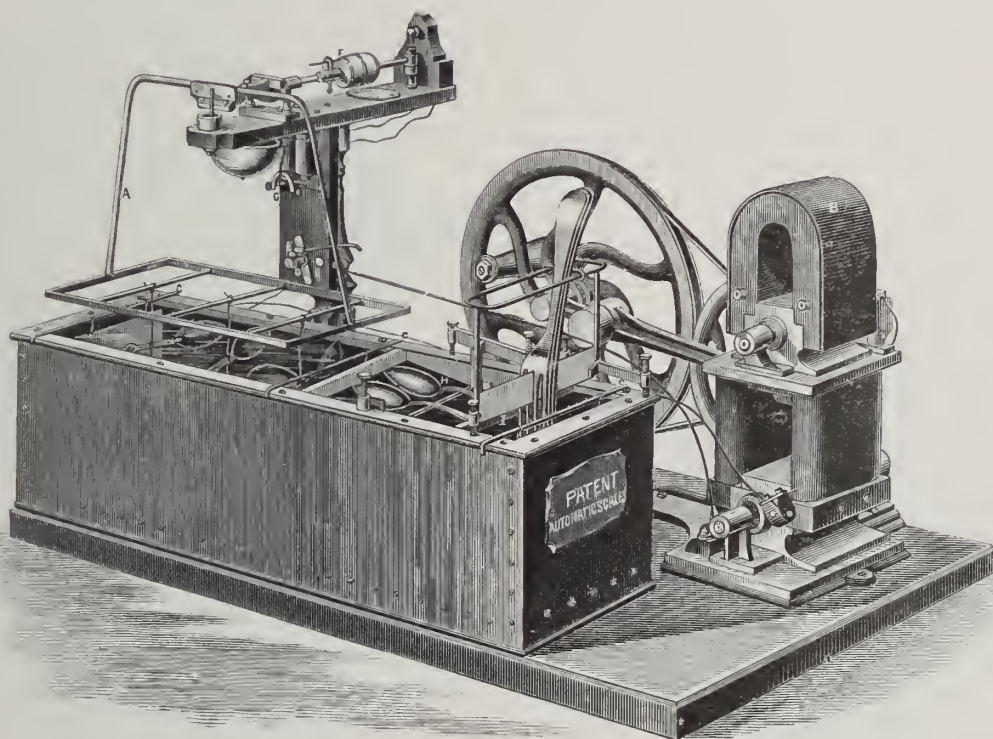

FIG. 1.

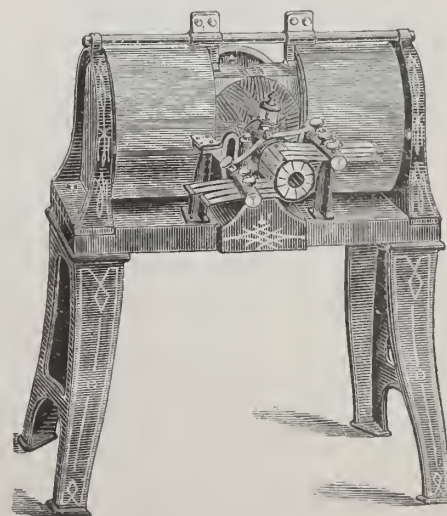

FIG. 2.—The Mather Dynamo-Electric Machine.

It supplies a more powerful and reliable current with less danger

of reversals from the vats, even when short circuited, and by an ingenious construction of the magnet and armature the annoyance of overheating common to most magneto-electric machines is entirely overcome.

From the record of improvements in manufacturing we naturally turn to the improvements made in the articles themselves, pitchers being among the most important. It was found that by applying to pitchers the same principle used in ice houses the same result was obtained, hence pitchers were soon constructed with double walls or shells enclosing an air chamber. Thus constructed they have obtained such success in preserving ice and the temperature of the water as to almost entirely supersede all others for that purpose. Formerly the inner shell or lining was composed of two metals, a nickel silver bottom and white metal walls; but it was discovered that in the event of the silver coating wearing off the junction of the two metals produced chemical action, tending to eliminate in the water a poisonous compound, although in an infinitesimal quantity. With the cry of "poison," however, the public took fright, and the manufacturers hastened to replace the objectionable lining with some material that would obviate the difficulty. The first, and also the best, improvement in this direction was the invention of a thin iron lining, covered, while at a white heat, with pure porcelain. The firmness of the iron proved a sufficient safe-guard against cracking or breakage of the porcelain, even when treated with great severity, and the porcelain itself, being subjected to the most thorough scientific tests, vouched for the preservation of purity in the water. Furthermore, if any unforeseen accident removed a portion of the porcelain and exposed the iron, such properties as might be taken up by the water would be rather conducive to health than otherwise. A still later device is an ice pitcher with an outside shell of *papier maché*, handsomely mounted in silver, fig. 3.



FIG. 3.—*Papier Maché Ice Pitcher with Porcelain Lining.*

These pitchers open a field for decoration limited only by the artist's skill, and being somewhat lighter than those with the metallic shell they are more desirable for many purposes.

The invention of the porcelain lining for pitchers suggested the application of the same thing to baking dishes for pastry, meats, puddings, etc., which, taken hot from the oven and enclosed in an ornamental silver receptacle, forms a double wall, retaining the heat and at the same time creating a beautiful article of table service. The accompanying illustrations show the different parts, fig. 4, as well as one style of the complete dish, fig. 5.

Chemical science is more closely allied to the manufacture of electro-plate than is generally supposed, and it will doubtless be a

surprise to many to learn that the chloride of sodium (common salt) contained in butter has an acidulous effect on the metallic base beneath the silver. It was discovered that when the silver coating

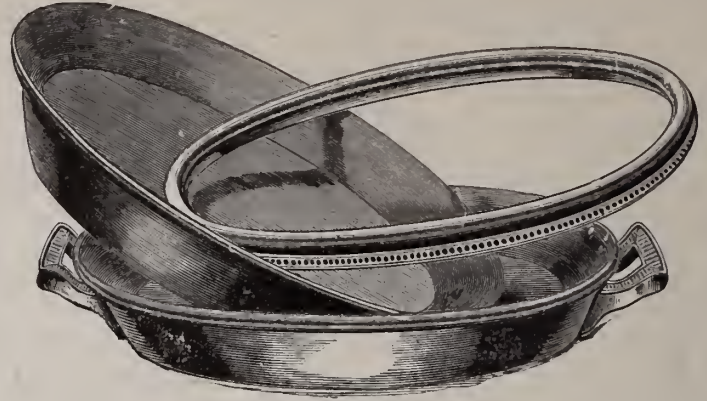

FIG. 4.



FIG. 5.—*Porcelain-lined Baking Dish.*

upon a butter dish drainer wore off, either through the friction of the knife or other hard usage, the metallic base of parts denuded of silver was filled with minute holes, as if by an acid. This unpleasant discovery was immediately followed by the invention of a protector,



FIG. 6.—*Butter Dish Drainer with Plate Glass Protector.*

fig. 6, made of plate glass with bevelled edges, which, while completely defending the drainer, at the same time clearly exposed to the eye the decorated silver beneath it.

A similar covering of bevelled plate glass is employed for salvers, of all shapes and sizes, protecting their highly burnished and ornamental surfaces from such scratches as necessarily occur from articles being placed upon them. (Fig. 7).

It will readily be seen how quickly the manufacturers of electro-plate met and overcame with improvements such obstacles to the durability of their products as have presented themselves, but there yet remains to be recorded an advance of still more striking importance. It was observed that when, after prolonged use, such articles as spoons and forks were returned for re-plating, those parts only most exposed to attrition were denuded of silver, while other portions still retained their silver coating. At first, to obviate this, small beads of solid silver were riveted to the bowls, heels and backs of

the handles. This process, however, proved both difficult and

silver had worn off plated articles they became useless, as there was no process by which they could be re-plated. In re-plating old ware such silver as may be still adhering to the metal base must first be removed. This is called "stripping," and is effected simply by reversing the electric current of the plating machine. The surface is then refinished and treated exactly the same as new articles. The value of old ware, therefore, is merely that of the metal and the labor expended in its construction, so that while in some cases it is economy to have the old re-plated, as a rule it is wiser to purchase new articles of later design and decoration.

(To be Continued.)

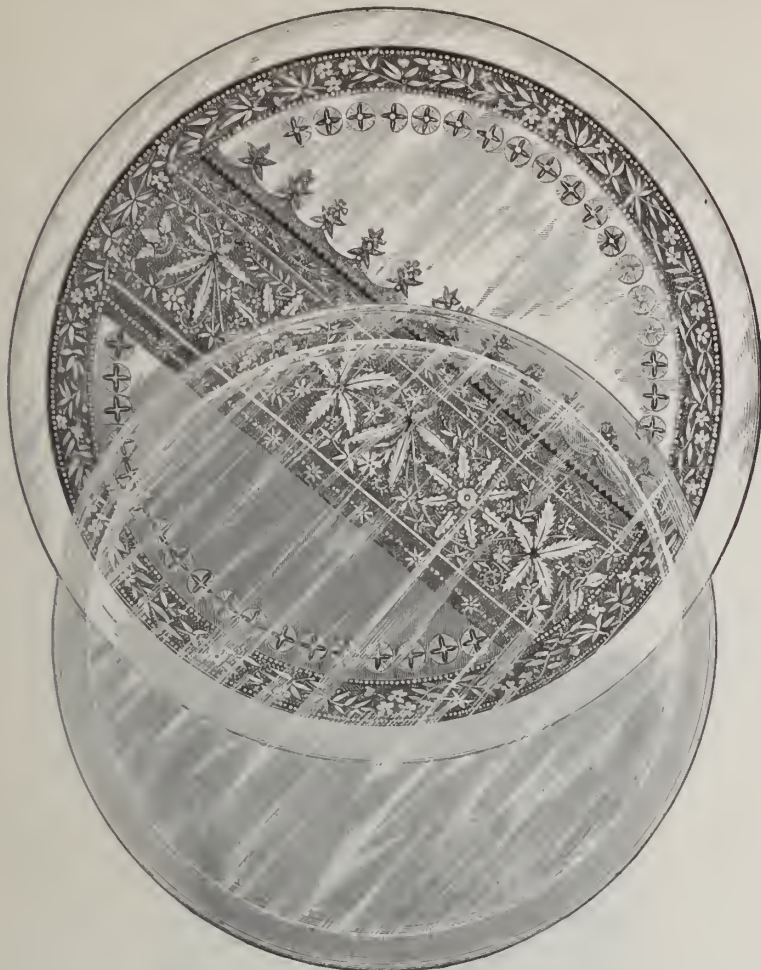

FIG. 7.—Plated Silver with Plate Glass Protector.

tedious, and a method was devised of depositing an extra coating of silver upon the exposed points by the electro machine. This was called "sectional" or "XII" plating, and will be more easily understood by the accompanying illustration, fig 8, and a reference to the frames II and I, fig. 1. The spoons or forks first being held in such a position that the heels of the bowls and backs of the handles rest in the solution as shown on frame II, those parts only receive a coating of silver which may be of any desired thickness. The same treatment is applied to the ends of the tines and tips of the bowls, by placing them in a vertical position as shown in frame I. Thus treated the durability of the article is greatly increased at a comparatively small additional expense.



FIG. 8. Sectional Plating.

The question is often asked: "How long will the plating last?" The actual durability of electro-plate depends as largely upon the care taken of it as clothing or any other article in constant use. If housewives would give, irrespective of cost, the same attention to electro-plate as to solid silver, the limit of its permanence would be greatly extended. With such care, presupposing it to be originally of the first quality, the silver coating has been known to last twenty-five to thirty years, while with rough handling its durability has been considerably lessened. If by the carelessness of servants, or the use of improper cleaning materials, the silver wears off, the articles can be re-plated. Previous to the discovery of electro-metallurgy, when the

How to Separate the Gold from Gold-plated Articles.

THE GOLD is removed from articles of iron and steel, without injuring them, by immersing them in a bath consisting of 10 parts of potassic cyanide and 100 parts of water, and connecting them with the positive pole of a battery. A wire or sheet of platinum is fixed to the negative pole. The position of the poles is hereby inverted, whereby the gold coating upon the iron and steel is dissolved in the cyanide solution, and partly deposited upon the platinum anode; it is then removed in a regular gold bath. Should there be only a film of gold upon the iron or steel, its removal may be effected by the cyanide solution alone, without the aid of electricity; the process is slow, however. Also silver, copper, and their alloys may, by this process, be ungolded, but the cyanide dissolves the silver and other metals at the same time; it is better, therefore, to effect the ungolding as follows: For the purpose of ungolding silver, heat it to a cherry-red, and immediately throw it into a pickle of more or less diluted sulphuric acid. The gold will peel off and fall to the bottom in the shape of spangles. Repeat the operation until all the gold has disappeared from the surface of the silver, which will then appear white and frosty. Light and hollow articles cannot be treated by this process; the preceding one is better adapted for them. For small articles of copper and its alloys, such as thinly gilt false jewelry, prepare the following bath:

Sulphuric acid.....	parts, 10
Nitric acid....	" 1
Muriatic acid.....	" 2

The large quantity of sulphuric acid promotes the solution of the gold, while only slightly attacking the copper or its alloys. The sulphuric acid is to be placed into a stoneware jar by itself, after which the mixture of muriatic and nitric acids, kept in well closed bottles, is gradually added, in tenor with the advance of the operation. The same sulphuric acid, if well covered, may be used for a long time, and its dissolving action stimulated by successive doses of nitric and muriatic acids. The operation must be watched by frequently withdrawing the articles, and when no more gold is visible it may be deemed as finished, and the copper has acquired a uniform blackish-gray color.

The nitric and muriatic (hydrochloric) acids may be replaced by saltpeter and common salt, both of which must be finely pulverized and stirred with a glass rod.

For large objects, such as clocks or chandeliers, concentrated sulphuric acid, of 66° Beaumé, is placed into a glass or stoneware vessel supporting two brass rods. One of these rods is connected by a conducting wire with the last carbon of a battery of two or three Bunsen's inverted elements, and supports the objects to be ungolded, which are entirely covered by the sulphuric acid. The other rod supports a copper plate facing the object, and is connected with the last zinc of the battery. The electric fluid traverses the sulphuric acid and carries the gold from the positive to the negative pole; as the copper plate is not prepared for retaining the gold, it falls to the bottom of the bath in a black powder, which is easily recovered. So long as the sulphuric acid is concentrated, and even under the action of the galvanic current, it does not sensibly corrode the copper, as it rapidly absorbs the moisture of the atmosphere. The vessel in

which it is contained should be kept perfectly closed when the ungolding process is not in active operation, and the pieces for ungolding should be placed in perfectly dry. If it is intended to sacrifice the gilt articles of copper or silver, let them remain in pure nitric acid, which dissolves all the metals except gold, which either floats at the surface of the liquid as a metallic foil or falls to the bottom as a blackish powder. If the liquor is diluted with distilled water and filtered, all the gold will remain in the filter, while the solution contains the other metals.

Advice to Watchmakers' Apprentices.

BY A MAN WHO HAS SPENT TWENTY YEARS AT THE BENCH

THE WRITER does not propose to write an essay on the punching press and die making, as this theme if treated at all exhaustively would fill the entire pages of this journal for a whole year, but rather to give such hints and suggestions as will enable the ambitious journeyman and apprentice to do such jobs of die press work as may enable him to experiment and work out his own ideas. The cut given with this article does not show a press of the best form for rapid work, but simply a cheap and tolerably good one, and one which will produce three or four thousand pieces or blanks a day. One fact should be borne in mind in all die work, and this is: the dies should not be permitted to pass one another to any great extent; in fact, about the best rule is to let the dies approach each other until you hear the die crush through. This crushing through, as I have termed it, is the effect of the yield or spring of the press, and will take place to some extent even when the press is enormously strong. The best method of insuring correct and constant action is not to rely on any screw or wedge, but by interposing pieces of sheet metal of different thicknesses between such parts as control the approach. In tempering dies, the lower or female die should be much the hardest, so that if one cuts the other the die which can be made the cheapest, and repaired the easiest, should be the one to suffer by the contact. The upper or male die can be faced off by grinding on a grind-stone, as the corners wear away; the same method applies to the lower die, but as this is much harder the necessity to face it off by grinding is less frequent. I give below the rule for determining the weight of castings, by first determining the number of cubic inches it contains. Another rule will come very near; and this is to weigh your wooden pattern, and if made of dry white pine, which is about the best material for patterns for medium and large sized castings, then multiply the weight (of the wood pattern) by 15. To illustrate: say your pattern weighs 3 pounds and 2 ounces; this multiplied by 15 gives 46 pounds 14 ounces as the weight of the casting. To determine the weight from the number of cubic inches, multiply by the decimal .281, and the result will be the number of pounds and decimals of a pound. The force required to punch metals can be estimated from the following rule: Multiply the product of the diameter of the punch and the thickness of the metal by 150,000 if for wrought iron and by 128,000 if for brass, and the result will be the force required in pounds. Example: What will the required force be for punching out discs $1\frac{1}{4}$ inches in diameter from No. 24 brass (American gauge)? As No. 24 measures .0201 of an inch in thickness, we say 1.25 inches multiplied by .0201 and the product multiplied by 128,000 gives us 3,200 pounds. A free use of oil will reduce this force some. It is well to know the strength of cast and wrought iron so as to be able to judge how much our machine will stand. The mean tensile strength of cast iron is about 20,000 pounds to the square inch, and it is not safe to subject it to more than one-half of this force. The reader will notice that everything in the way of expensive fitting, requiring lathe and planer work, is carefully avoided; all the fitting required can be done in a shop of very limited facilities; a heavy vise being about all the tools required. The drilling of the large holes can be done at a machine shop, or even a blacksmith who has facilities to drill could do it, but a large foot lathe, if the work is

blocked up, would be best for drilling. It is desirable that dies should approach each other as nearly parallel as possible, and all shearing motions avoided, as this has a tendency to divert the dies to one side.

At fig. 1 is shown a side elevation of the punching press. It consists in principle of two strong iron jaws; the front teeth, so to speak, forming the cutting dies. These jaws are hinged at *g* by a strong bolt; this bolt does not pass through holes but lies in V-shaped notches. This system of V-shaped notches can be substituted by a taper pin, but the taper pin is so much more difficult to make, and also the holes, which need taper reaming. This will be explained with detailed drawings, giving sizes and action, in our next issue. These jaws are drawn together by the two pieces *dd*. These pins are attached to the upper jaw *b*, by a bolt shown at *h*, fig. 2. These pieces (*dd*) pass on the outside of both jaws and are connected with the pendulum lever *e*, by a bolt shown at *i*, fig. 2. It will be seen by inspection of fig. 1 that *d* does not descend perpendicular but obliquely. Now the upper part of *e* ends in a projection *k*, which is also jointed by a bolt to two lugs on *c*, and *c* is composed of two pieces slightly separated by putting pieces of metal between them so as to cause the dies to just pass each other as described above. In action the foot is applied to the weight *n* (which should weigh about

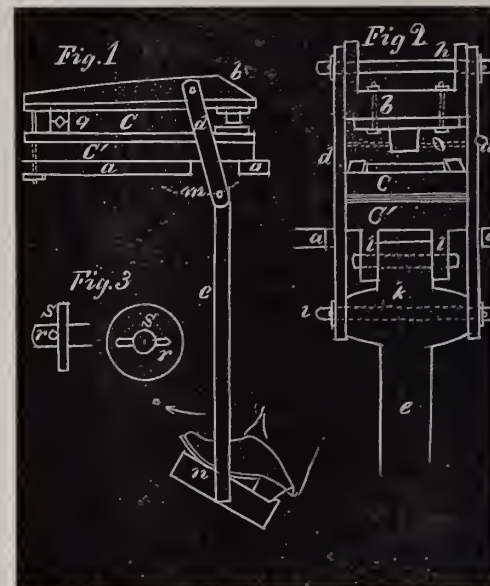

15 pounds,) and on pushing the weight forward (swinging it as a pendulum) the piece *k* turns in lugs *ll*, which are attached to the lower half of the jaw *c*, and the straps *dd* swing on the line *m* and in conjunction with the piece *k* form a knee joint action which ensures the greatest force at the instant the dies attack the metal. The momentum acquired by the weight *n*, enables us to cut out pieces which, if a direct lever action was used, would require a considerable weight, and the knee joint arrangement in conjunction with the double jaw *c*, and interposed pieces of metal save the dies from cutting one another, as when a momentum screw press is used. This form of connection also opens the jaws as the weight *n* swings back. The upper die should pass through a plate of metal, as shown at *o*, fig. 2; this draws the upper die from the metal sheet which is being punched and leaves it free to be moved. At fig. 2 is an end view of the press enlarged so as to show more of the details. The bolts *h* and *i* can be made of round charcoal iron. I suppose most of my readers are aware that round iron wire up to $\frac{3}{4}$ of an inch in diameter comes in pieces 3 feet long, and almost as round and straight as if it had been turned, and is entirely free of scale. Such rods will make the bolts *p* *i*, and the joint at *g*. A rod for such a press should be about $\frac{1}{8}$ in diameter. The ends of these bolts can be drilled and a pin put through, as shown in fig. 3, where *p* represents the bolt, *s* a washer and *r* a wire pin to keep the washer in place. This plan is better than cutting screws on them, as cutting a screw with an ordinary plate or dies enlarges the wire and consequently would not pass through the holes. There is but slight

tendency to displace the bars *dd* at best. The bars *dd* are best made of wrought iron 2 x ½ inch in cross section, if cast iron is used they should be ⅝ x 2. The wooden patterns for this press can be cheaply made, and the castings when received from the foundry should be *pickled* by brushing them over with a mixture of sulphuric acid and water (4 of water to 1 of acid). A swab of old cotton cloth wrapped around a stick and tied with a string, serves to apply the acid mixture. The pickle should be brushed over the castings 3 or 4 times and allowed to stand 24 or 28 hours, when on washing with water the hard sand scale will slough off. The front end of the jaws where the dies go should be filed flat and true. This press will easily exert a force of 2 or even 3 tons at the time of contact of the dies. The bolt through the lugs *ll* should be of the same size as *p* and *i*. At *a a*, fig. 1, is shown the plank forming the bench and should be 1½ or 2 inch plank. The strength of wrought iron is about 50,000 pounds to the square inch and can safely be estimated as safe at three times cast iron for tensile (pulling) strain, but cast iron is strongest to resist a crushing force, and is much the most rigid metal.

[Special correspondence of THE JEWELERS' CIRCULAR.]

A Trip to the South African Diamond Mines.

Concluded.

ANOTHER peculiarity worthy of being mentioned is the proportionally great number of diamond splinters found in the dry diggings—fractured pieces, which at the corners and edges plainly show their original crystalline form, while the completing fragment has, to my knowledge, never been found. Highly interesting, finally, are those diamonds taken from the soil in an uninjured condition, in whom flaws and fissures become visible after the lapse of a few days or weeks, and which frequently burst spontaneously into a number of valueless splinters. Whether this occurrence stands in any connection with the crystalline form (it is said that this splintering most frequently occurs in octahedrons), whether it is due to an unnatural grouping of the carbon atoms, or a rapid cooling of the lately formed diamond—analogue to the inclination to bursting observed in the well-known glass tears, and artificially produced by a rapid cooling of the heated glass mass—are problems that cannot be solved at the present time. That the said diamonds, so long as they are inclosed in the earth, remain intact, might perhaps be due to their remaining sheltered against the extreme influences of temperature, while, when in air, the changes of the latter causes an unequal expansion or contraction of the outer and inner layers of the crystal, thus producing flaws or splintering.

As far as the division of the diamonds in the basin of the New Rush Mine, and the yield of the latter is concerned, it is found that claims immediately bordering on the reef are the richest, and, consequently, worth the most. I have known cases when the one-fourth part of such a claim was paid for with £5,000.

I have already stated that garnets are frequently found in the Dry Diggings, but that this gem should be a direct indication of diamonds—that bonanzas of diamonds are found in places where garnets occur—that a certain alternation between large and small diamonds is observed in the tufa layers, according to the opinion of diggers, and that, consequently, where small diamonds are found large ones need not be expected—are all assertions which completely lack corroboration. Concerning the total yield of the New Rush Mine and the many reports bordering on the incredible of its richness, are barely exaggerated, since the value of the jewels dug here from 1871 to 1873—therefore, a period of only three years, is estimated at £9,000,000, and, according to the official statement of A. v. Brönsdorff, the general postmaster of Griqualand-West, in 1879, diamonds to the weight of 3,157,186 karats, which, taking the average price of the karat only at twenty-five pound sterling, would represent a value of nearly £4,000,000 sterling, passed through the Kimberley post office to Europe. If we consider that the jewels sent by mail represent only one-half, or at most two-thirds of the total yield

(since many are carried home by the diggers themselves), it would not be extraordinary if the annual yield of New Rush at the present time is estimated at from four and one-half to five millions karats, of a value of near six million pounds sterling.

I have endeavored to convey to your readers a picture of the New Rush or Kimberley Mine (the one with which I became best acquainted during my residence in the diamond fields), and I will draw my correspondence to a close by making a few remarks on the town of Kimberley itself, the climatic proportions of the vicinity, as well as the presumable geological process to which these mines owe their existence. I stated previously that the town, built at the foot of a low "kopjie," and stretching out at a length of from one and a-half to two miles, consists of tents, frame houses, or, what is most frequent, of iron cabins, lined with wood or cloth; its churches, hotels, concert and other halls of pleasure, built after the town had barely existed one year, are also entirely constructed of this metal—a material that offers the advantage that buildings may within a few hours be taken down and erected again in some other part, while it possesses the disadvantage that it offers little protection against the violent climatic changes of the country. The society of this town is composed of all possible nationalities and ranks. Together with the boer, who left his farm to the care of his oldest son, in order to become a rich man in a short time, and who has acquired a share of some claim, and generally erects no regular building, but lives in an ox wagon on the outskirts of the barrack-town, and prepares his meals under the open sky—we find the small trader from the Cape Colony, the enterprising Yankee, the former Californian and Australian gold digger, the English, German and Dutch diamond trader and speculator. From the son of the English lord, whom quest of adventure and desire for change brought to the diamond fields, down to the tradesman, who as blacksmith, carpenter, etc., earns an excellent living, all classes, castes and ranks are represented here. In the hotels, where enormous quantities of strong alcoholic liquors are consumed daily (the bad condition of the drinking water has led to the habit of mixing it with spirituous liquors) one is little troubled with stiff-backed ceremonies. At the long table, covered with a suspicious-looking table cloth, laid with gapped-out knives and two-pronged forks, the digger, frequently clad only in a pair of linen breeches and woolen shirt, with sleeves rolled up, just as he emerged from the sorting table or claim—takes his seat, to fortify himself for fresh struggles by a simple meal. The conversation, in English, Cape Dutch, frequently German, is on only one subject, exceeding in interest all others—the most recent diamond finds, the sale of a claim lately disposed of at a fabulous sum, or the thefts of diamonds perpetrated by the rascally Kaffirs. As previously remarked, the latter are of daily occurrence, and although these black rascals may be watched as closely as possible, it is impossible to do so effectually. For the protection of the miners, and to counteract the pilfering of these sable sons of the desert, a law was passed that no colored man can own a claim or be a partner in one; it was invariably found that they became "fences," selling stolen diamonds under the pretext that they had been dug from their grounds.

When I spoke of the magnificent finds made in the New Rush Mine, the reader must not conclude that there are only prizes in the lottery of diamond digging. A large number of diggers can be found who, after a fatiguing work for months, have barely made enough to cover expenses, while others have had to suffer hunger and privations. The difficulty of raising the "stuff" increases with the depth of the mine, as well as keeping the claim free from water etc., and this is the reason why the majority of the claims at New Rush, Dutoitspan and Bultfontein have passed into the possession of companies working with a large capital. The cost of living is another circumstance equally rendering difficult the continued residence of the poor miner. With the exception of meat, furnished in large quantities by the stock ranches of the Orange Republic, provisions are extraordinarily dear, for instance, from £2 to £2½ per

100 pounds flour, 12½ cents per egg, etc., while the price of all other goods is in proportion, since they must be transported by ox wagons from the coast. Black workmen are plentiful—the Zulus, Amantongas, Betjuanis, and other Kaffirs visit the mines in droves, and when they have saved or stolen sufficient to buy a gun, ammunition, and a woollen blanket, they return home, in consequence of which laborer's wages are very reasonable, while those for white girls and tradesmen are very high.

As far as regards the climatic conditions of the diamond fields, the changes of temperature are very sudden. These changes are most felt at the end of summer (March and April), when the days are still boiling hot, while the nights, in consequence of the rapid radiation of the ground, with an unclouded sky, are generally icy cold. It is a very common occurrence at Kimberley that after sunset the thermometer falls from 10 to 12° R. within two hours. I have been assured that the mercury sinks in winter time to —12° R., while in summer the temperature in the shade during the first hours of the afternoon reaches at times a height of from 38° to 40° R., due to the radiation of the sun's heat from the bare soil. That under such conditions, together with the insufficient protection offered by tents, board and iron shanties, the lack of good drinking water, and the absence of the most indispensable sanitary observances, malignant fevers, dysenteries and other diseases frequently make sad havoc among the population, should not be wondered at. To return to the climatic conditions, the periodically recurring north-west winds, Sirrocco-like, sweep before them immense clouds of dust and sand, whereby a residence is made almost impossible on account of the continual dust, at the places where the work of transporting and sorting is constantly going on. All pursuits are naturally suspended on such a day, and everyone seeks to shelter himself against the violence of the storm, which often appears in the form of powerful cyclones. The terrible thunderstorms which, as previously remarked, occur periodically in the sterile parts at longer or shorter intervals, are also worthy of being mentioned. Such a tempest, upon the table lands north from the Orange, is of an indescribable and terrific grandeur. The clouds appear to scud along at a small distance above the ground, while thunder and lightning commingle into one overpowering roar, and electricity is frequently so powerfully developed that the iron tires and other parts of carts and wagons are luminous, and that iron utensils as well as hyena, jackal or leopard skins emit sparks when touched.

The most wonderful hypotheses and theories have been established to account for the geological development of these diamond fields. For instance, it was deduced from the presence of slate and sandstone in the diamantiferous tufa, that the diamonds, together with the strata surrounding them, were transferred by means of water to their present place; the State geologist of the Cape Colony, Mr. E. J. Dunn, among others, asserted that diamonds were only to be found in the sand, and had, together with the latter, been blown into the fissures.* That the dry diamond mines (New Rush, Dutoitspan, Bultfontein, Old De Beer, Coffecfontein, Jagersfontein, and a few others) are entirely due to volcanic agency, was long ago recognized. The shape of the basins in which the diamonds are found, the never absent crater-like "reef" in the stratification of the shale clay, pitching toward the exterior, betraying both a pressure and a central elevation from below, whereby the reef was formed, as well as the condition of the calc-tufa itself, which, although it has suffered from many decompositions and changes, still differs very essentially from all the other rock and earth formations of the South African table lands, unmistakably points to another source than that of the sedimentary rocks of the country. Again, the utter absence of anything like washed holders in these basins signifies that water has had no

share in the formation of the diamantiferous "stuff." Concerning the sand veins, or the lime mixed with sand, found among the blue "stuff," there is no doubt that they stand in no relation with the diamantiferous mass, but owe their origin altogether to atmospheric influences.

As far as the river mines are concerned, which I only could mention hastily, the fact that diamonds are not found in them beyond a depth of six feet, leads to the presumption that the latter were either washed away from their places of origin, or that these were destroyed altogether, whereby the diamonds were liberated and washed into the rivers.

What will be the future of the South African diamond fields? Will they be exhausted with time? These are questions that can barely be answered with certainty. But as the territory of the diamantiferous region is very large according to all appearance, and as new mines have been discovered during the last few years, for instance, the above-mentioned Jagersfontein, near Fauresmith, in the Orange Free State, it need not be feared for the present that this source of revenue of the South African commonwealth will soon cease. How great the advantage reaped by South Africa from its diamonds are, may be learned at a glance from the exports and imports of the colonies, which have almost tripled during the last decade. While a pale face, thirteen or fourteen years ago, belonged to the rarities, where the griqua hunter followed the tracks of the game in the dreary, uninhabited desert, the shrill steam whistle may be heard to-day, and people of all nationalities are busily engaged in raising the treasures that have slumbered for thousands of years within the womb of the earth, into the light of day. Beside the direct benefits—the influx of capital and increased immigration, consequent upon the discovery, the indirect ones also are not to be underestimated. For instance, the use of the steam engine for the work of the mines was followed by the discovery of coal in the Orange Free State and the northern parts of the Cape Colony, whereby transportation and trade and commerce will be much facilitated in these regions.

That the "black diamonds," might also contribute their share toward unlocking the "dark Southern Continent," was my parting wish, when, after a three weeks' residence, I left the diamond fields of South Africa.

Yours respectfully, JAN.

A Stroll through a Watch Factory, and the Finishing of Blank Works According to the Swiss Method.

BY OTTO BEHREND, OF ST. PETERSBURG, IN *Deutsche Uhrmacher Ztg.*

Continued from page 28.

AFTER completing the escapement, the adjustment begins. The regulator pins and keys are first made by the regulating and adjusting workman. If half-ready regulators are used, the necessary holes must be drilled in them, in accordance with those in the balance stud, and describing the same circle upon which the latter is located. The stud was mounted already by the escapement workman, at a height suitable to the spring collet and space between balance arms and bridge. These holes are already drilled in finished regulators, and the one in the stud is to be drilled conformably.

The holes in the ready regulators are freed from dirt and burr with a chamfer, and the pins are next driven in with a punch, having a small round polished hollow. They receive a small roundish head hereby. In their length, they must stand so much behind the surface of the stud as the thickness of the regulator key amounts to. Brass or German silver oval wire is used for the latter; in its absence, flat rolled or hammered wire may also be employed.

A cutter is used for making them, whereby the work is much expedited and facilitated, and the description of which is hereby appended. One end of a piece of round steel, 50 mm. long and 3.5 to 4 mm. thick is filed flat, and a center is filed on the other. A hole of 0.5 mm. in diameter and 2 to 3 mm. in thickness is next drilled in the turning tool into the center of the flat end. At the bottom of this hole is drilled another one of about 5 mm. diameter, and 5 mm.

* The views of this gentleman, as far as absurdity is concerned, find worthy companions in those of the geologist Gregory, who, in the year 1869, while the river diggings were in course of development, firmly and obstinately asserted that Griqualand-West contained no diamonds, and those pretended to have been found had been deposited there by land speculators, in order to raise the price of real estate—an assertion to which he obstinately adhered even after diamonds to the value of more than £100,000 sterling had been shipped to England.

farther on a second one in the same direction with the first, square through the steel. The space between these two holes is cut or filed out, so that a cut-out of 6 mm. long and 2 mm. broad is produced. The sides left standing serve for springing, as we will see farther on.

The fore part, into which the small hole was drilled, is cut into two halves in the direction of the open sides of the square, by means of a fine saw, whereby each one remains together with the side of the square.

Fig. 1 represents a cutter of this kind on an enlarged scale, while fig. 2 shows the cutting edges, as seen from above. The latter are formed by filing into each half two right-angled grooves, which must not be too short in the length direction of the steel, so as not to make the cutting edges too conical.

The cutter is cut open in the direction *a b*, and opens in the direction *c d* (fig. 2). The set screws *s n*, fig. 1, which pass through the springing sides of the cut-out, serve for opening or closing the cutting edges, whereby the greater or smaller thickness of the tit or axis, which is to be inserted into the pole of the regulator, is produced. When the cutting edges lie very close together, or, in other words, that the cutter is entirely closed, the holes are extremely small. After this description, the functions of the little instrument will be easily understood. An eccentric center is filed to the wire, so that the tit to be cut comes on one side, thus obtaining metal for the remaining foot, the actual closing. The center is inserted into the hole and examined by a few turns of the cutter whether the tit becomes of the right thickness. If not, the set screws are regulated accordingly.



The tit having been finished, a piece of work quickly performed, when the cutter has been set to order, the place, permitting the shake of the spring blade, is filed at equal height with the already fitted pin, its exterior shape is next given, and finally shortened at equal height with the stud, and riveted with the aforementioned punch, so that it fits neither too light nor too loose.

A cut for inserting the screw driver is finally made in the stud as well as the spring key.

The bridges, finished so far, together with the balances, are sent now to the regulating workman, whose work it is to weigh the latter, so as to choose the balance springs thereby.

A single glance at the balance cock tells the regulator what size number he has to use, and he ascertains the requisite strength with the same speed, by glueing a balance spring by means of wax upon the balance staff, and setting this into vibrations. If it is approximately suitable, the right number in both size and strength has been found for all six movements, and the springs are mounted upon them at once—in case that one or the other balance should differ, being either too light or too heavy, the strength of the spring is varied by one-quarter or one-half number.

When all the springs have been mounted, so that they run flat as well as round, regulating commences. This is done either in the well-known manner, by timing with a correct watch, which the regulator holds to his ear with the left hand, while the right holds the spring with a pair of tweezers, causing it to vibrate, and comparing its swings with those of the watch, thus finding the fastening point of the spring, or using the regulating machine. This machine, invented by F. Racine, of Chaux-de-Fonds, is as follows: Upon a plate, 9 centimeters long and 6 centimeters broad, resting upon four feet, two bridges with jewel holes are fastened near one of its corners, in which a heavy balance, two centimeters in diameter, vibrates, which by a pretty large balance spring is regulated exactly to 18,000 vibrations.

A pillar, 4 cm. high, standing upon the plate and revolvable around its axis, carries a vertical movable arm, on the end of which is fas-

tened a small pincers, revolvable around its axis, with points one cm. above the surface of the plate, when the arm is placed horizontally. It is provided with a screw, and serves for retaining the outer end of the spring to be regulated.

Owing to the two-fold motions of the parts, the balance to be regulated is placed so that one of its arms stands exactly opposite to the standard, when both are simultaneously set into motion in the same direction.

It can be seen even after a few vibrations whether the mounted spring is too slow or too fast, and the point retained by the pincers is altered accordingly. If, however, the difference between the two is only a trifle, and the less expert should be unable to decide whether the spring to be regulated is slower or faster, then the only sure way to clear all doubt is to count the vibrations up to the time they begin to deviate. Supposing 50 vibrations were counted in this manner, while the 51st, etc., are no longer in unison with the standard spring, the mounted spring is lengthened or shortened by 1 mm., and the counting begins anew. If the wrong correction was applied, it would soon be ascertained by the vibrations becoming more unequal; in the contrary case, the balance will be regulated approximately, and when 150 vibrations of equal duration can be counted, it may be regarded as perfect.

With a little practice this work is the labor of a few minutes, and I hold the regulating machine to be a very practical instrument, and can highly recommend it to my brother watchmakers.

When all the hair springs are regulated in this manner, and the point at which it was held by the pincers has been marked by a slight bending, they are fastened in the stud and mounted upon the bridge, whether the outer coil lies correctly in the circle described by the regulator, whether the collet lies correctly in the center upon the jewel hole, and the second coil does not approach too closely to the stud.

When all this has been arranged, the springs are again mounted upon the balances, and remain upon them, so as to guard against mixing.

We arrive now to another part of the fabric, that of the repairers (repassers).

The factory watchmaker understands something entirely different by the word "repairing" (repassage) than the ordinary repairer; to him it means the perfecting of rough movements as far as gilding, after the insertion of the escapement. Hereto belongs: The mounting of the minute work, the finishing of the barrel parts, the fitting of the movement into the case, the finishing of the bridges and potances, the correction of the depthings, the tempering of the screws and polishing them, as well as the other steel parts, and the polishing of these parts in case that they are not to be gilt.

Nearly all these branches are executed by specialists, although it is required of the repairer that he should be able to perform them all himself.

Not to get ahead of the systematic division of work, let us first turn to the hand mounter (poseur d'aiguille).

As we stated in the introductory part of this article, the raw works are generally obtained with the dial already mounted, and in this case the latter contain the proper holes for the dial feet. If this is not the case, their mounting begins before putting in the escapement.

The hole is next drilled with a diamond into the center of the plate, down to the copper plate, by using an instrument similar to an uprighting and drilling tool—(the copper plate is not attacked by the diamond, and, consequently, must be perforated with a drill or graver). This is done while the dial lies upon the plate, the latter of which is centered with the lower center, so that the hole comes exactly in the middle. The dials are dismounted again, and the holes drilled into the plates for the dial screws, threads cut in, screws inserted, the passage for the dial feet filed out, the same done at the feet for the screws, and the feet shortened, rounded off and polished. The screws are then laid again into the corresponding hole of the box.

It is of advantage for the consumer to purchase raw works with dial plates in place, since these are fitted to the movements, and the feet are inserted in their appropriate places.

A canon pinion with a minute wheel is next placed into the depthing tool, and the depthing distance transported upon all the plates. With remontoirs also, the depthing of the minute wheel in the hand-setting wheel is to be set, and marked upon the plates. The hole for the minute-wheel steady-pin is drilled next, the thread cut in, and the sinks for the canon pinion, hour and minute wheel made.

When ascertaining the minute wheel center point, care is to be paid that either it or its sink comes neither too close to the sink of the barrel nor that of the third wheel. However, if it is necessary, owing to the construction of the movement, that the minute wheel sink laps over the circumference of that of third wheel, attention must be paid by turning out of the former that at the point of contact of both, sufficient metal remains standing that no hole opens in the plate.

There is no standard for the shape and depth of the sinks; it is rather left to the intelligence and circumspection of the workman to proportion everything according to the construction of the work, so that the pinions are neither too high nor too low, the wheels neither too thick nor too thin, and the space for all parts be neither too large nor too small.

The sinks being completed, the minute-wheel pin is screwed in and filed down so far from above that little shake remains between it and the dial. The other end, containing the thread, is shortened at the same height with the plate, and both ends rounded and polished. The minute wheel pinion, which is generally too high, is filed lower, according to the measure of the steady pin. If the pinions are hard, they are boiled in oil until this ignites.

The center-wheel pivots are turned off to their right length, the center staffs turned, fitted in, and the canon pinions mounted. The pinions of the latter are turned lower from below, if too high, and the canon turned off in case it should run untrue.

The hour canon is next opened so that it fits exactly to the canon pinion, and turned so that the hour hand fits upon it.

The height of the center staff and the hour canon is to be measured exactly, so that the hands stand neither too high nor too near above the dial. For facilitating this labor, the factory workman has a gauge constructed of a strip of brass about four centimeters long, similar to a rule for the double calipers, into which a cut is filed of such a depth that when the strip is applied with its edge upon the dial, the upper rim of the cut is just touched by the end of the center staff. This height, in 18 to 20 line watches with seconds hand, is about 1.5 mm. This measure is now suitable for all watches of the same caliber, and facilitates work very much.

A little sink is finally turned in the hour and minute wheel by way of ornament, the face of the minute pinion ground flat and polished, and the wheels ground, to be polished and gilt together with the others.

The flat grinding and polishing of the pinion faces is done upon an iron or glass plate, by inserting the point of an arbor or something similar into the pinion hole, and setting it in motion thereby.

The minute works finished, the single parts are marked, and, if necessary, the depthings corrected, before the wheels are ground, next mounted and delivered to the visiteur for his inspection, and taken down again.

A workman skilled in this branch finishes from two to three boxes daily, according to quality.

Next follows the finishing of the barrel and parts. It is, perhaps, unnecessary to say that the single parts of each movement must be numbered before or during the work.

The hole for the spring hook is first drilled into the barrel and a thread cut in. This is done before turning out the barrel, so that the burr arisen from drilling and cutting is removed by turning. All covers are fastened upon, with their inner sides outward. The first barrel is then fastened by the teeth upon the graver, and the inner

side of the cover turned out, leaving only a small rim. The cover is next reversed, without taking down the barrel, and the space for the stop-finger as well as the outer cover rim is turned. The rims are neatly beaded and everything turned so finely that a subsequent grinding is not necessary. The cover is removed next, and the barrel turned out within. Attention must also be paid so that the rim of the barrel is left neither too thick, nor turned too thin. In the first case, the space for the spring would be too small; in the second, the cover would not have sufficient hold. The average is easily learned by experience, and definite rules cannot be laid down.

All the six barrels having been set to order in this manner, the covers alone are placed in one after the other, and the space for the female stop turned out. When also this has been done, the spring cores are measured with the third gauge, whether they stand in correct proportion to the barrels. They are generally somewhat too large, and in such a case must be turned down appropriately.

The hooks are next made into the cores and barrels, whereby attention must be paid not to leave them higher than necessary. They must protrude only very little beyond the spring blades. Examination is next to be directed to whether the barrels do not pinch upon their pivots. They must run smoothly, but their shake upon the barrel arbors with core screwed on is to be very small, in fact, barely perceptible, since by the subsequent grinding of the barrel it is still enlarged. We now arrive at the stopwork, which, when set into order and tempered, with lower square of the barrel arbor shortened so that with bridge screwed in place it does not touch the dial.

The work on the barrel with parts is ended by fitting in the mainspring with 12½ or 13 coils.

What skill workmen acquire in the different branches, is also seen here; an active hand only consumes 20 or 25 minutes for turning out the six barrels and covers.

The barrel parts being completed, the fitting in of the movements into the cases is next in order, for which purpose the latter must be rough-ready—that is, the dust-cap, bezel and bottom are simply sprung into place, the joints made, but not finished, and without pins, so that the parts may easily be removed or put into place, according as the work demands it. Cases with spring closing must have the springs put in.

The appropriate place for the movement screws is first determined. When employing two screws, only one fastening pin, which prevents the movement from turning, is required; with one screw, three pins should be put in. When the place for the screws has been marked in a suitable distance from the plate rim, their holes, as well as those for the fastening pins, are drilled, and the thread cut into the former. The countersinks are next made for the screw-heads.

The screws, selected so that their heads fit into the countersink, are next screwed in, and that part protruding beyond the rim of the plate is filed away.

The pins are next filed and driven in. At the time of drilling the holes for them it must be done cautiously, so that they are placed at a suitable distance from the plate rim. If they were drilled too low, it is plain that the pins would not comply with their functions.

The dial is mounted next, and the plate laid in such a manner upon the center piece that the 12, or, with hunting-case watches, the 3, stands exactly in the center of the pendant, when the point is exactly marked upon the case rim where the fastening pin in the plate is situated, after which a notch is filed into the rim for the reception of this pin. This work must be done with exactness, since the slightest deviation would place the movement obliquely into the case, and the watch be disfigured thereby.

When all the plates have been placed in this manner into the case in regular order, and should they be hunting case or spring-closing cases, they are examined whether it is necessary to cut or file out the cases for the free motion of the spring, which is generally the case.

After also this has been done, both the dial and the bottom, which were necessary for the testing of the case springs, are removed, the barrel bridges screwed upon the plates, and the dust caps sprung in place. The whole, consequently, the center piece with the plate in it, and the dust cap, is placed in the graver, being centered by the hole in the barrel bridge, according to which the hole for the winding square is turned in the dust cap, and at the same time also that for the hand square, being centered according to the center-wheel hole in the plate. Since it would not appear nice if the holes in the dust cap were too large, a fitting key may be used as a gauge, and the holes are turned sufficiently large that the former has plenty of shake in it. But if the caps are to enter into the dust caps, the holes in the latter are turned after the former have been finished.

The dust caps are removed next, the spring arbors and center wheels mounted with their bridges, the center staffs inserted, and the dust caps again returned to their place. In this condition the squares protruding above the dust caps are shortened with nippers, and filed flat even with the dust cap, after which everything is removed again and the caps screwed upon the bridges, in order to file them down until the dust cap presses upon them no longer, in case the latter is not to enter into them.

The bridges are now unscrewed, and fastened upon the graver, and the canon of the top is in this manner turned from within and without. When turning out from within, the graver must be prevented from going in too deep, and damaging the bridge thereby. The process of turning cannot be watched, but by a little practice it can plainly be heard when the cap is turned through.

The upper rim of the cap is next turned with a suitably formed graver. In place of the graver an instrument is also used which is manipulated by free hand. It is easily made from an old pinion gauge, one of whose arms is shortened by about 5 mm., and a notch made in it. When using it, this notch is placed upon the rim of the canon, and the longer arm braced against the inside of the wall, whereby the suitable distance of both arms is regulated by the screw of the gauge. The instrument, thus set, is then twirled a few times between the fingers, by holding the cap firm, and the work is finished.

(To be Continued.)

Views of Correspondents.

This department of THE CIRCULAR is open for communications relating to the jewelry trade, but the editor does not hold himself responsible for the sentiments expressed by contributors. We invite correspondence, but require that it shall be free from all personalities, and the writer's integrity guaranteed by the disclosure of his true name to the editor. Anonymous communications will not be noticed.

WHO OWNS THE GUILD STAMP?

To the Editor of the Jewelers' Circular:

I have read with much interest your articles relative to the Guild stamp, and have been much impressed by the fairness with which you have discussed the question. But there is one point regarding this stamp with which you are possibly not familiar. I am informed that when the Guild approved of the stamp and authorized a contract to be made with the Racine (now Rockford) company, the parties to the contract were the Racine company and W. N. Boynton, president of the Guild, and not with the Guild. In fact, the Guild not being incorporated, no contract with it would be binding in law. If the contract is made with Mr. Boynton as an officer of the Guild, it has no force in law, and the bonds executed by the Racine company are in no way binding upon it; if executed in favor of Mr. Boynton individually, then the Guild is interested in it only by his sufferance; if he should cease to be president, he could claim the contract as his own, and refuse the Guild all the alleged benefits to be derived from it. Then the stamp itself is patented, but in whose name I have not heard. Suppose the manufacturers of the Guild stamp goods choose to sell them to outsiders, who is competent to prosecute them for the forfeiture of that \$1,000 bond we have heard so much about? The Guild can have no standing in court, not being incorporated, and no right to "sue and be sued." The whole busi-

ness looks to me very much like a nice little job manipulated by some one for individual glory if not profit. Another objectionable feature lies in the fact that under the rules adopted for buying the Guild stamp goods a dealer has to make application for them, and this application has to be endorsed by Mr. Boynton that the applicant is a member in good standing—i. e., has paid his dues—of some state association that is tributary to the Guild. Thus Mr. Boynton is constituted the sole arbiter of a dealer's standing and right to recognition. He can give full scope to his personal likes and dislikes, but, unless a dealer can obtain his favorable endorsement, he cannot buy Guild-stamped goods. This is rather too much authority to vest in one man. I have no doubt but a Guild stamp, properly handled, would be a benefit to the trade, but such close corporation contracts as Mr. Boynton has made cannot but defeat any good that might otherwise be accomplished by it.

DEALER.

Iowa, Nov. 12, 1882.

CHEAP NICKEL CLOCKS.

To the Editor of the Jewelers' Circular:

I have a grievance; and, on behalf of myself and many others suffering the same infliction, I appeal to you for help. The infliction referred to is the flood of what we include in the name of "nickel c'ocks." To me (and I am not alone in saying this) they are an unmitigated nuisance—without even one redeeming quality. I have yet to find the first retail dealer who likes them, and I have more than once had traveling agents for the clock companies admit that the manufacturers regretted ever putting them in the market. A large proportion of these clocks take the place of a better one which need not necessarily cost more, while many who can well afford a better one buy these. Often they get them at large retail dry goods stores for less than we can buy them for, and when they need any repairs anyone who ever repaired one knows that it takes longer than an ordinary 8-day striking alarm clock put up in the usual way. They are not half as good timekeepers as pendulum clocks, neither are they so durable. I have one that I bought before Christmas that I have not had time to put in a salable condition, and all it needs is to have the hour hand moved forward a little to match the minute hand. To do this I must take off all the keys (hand-setting and winding), alarm key, two legs, the bell, and handle of the case, with its various appurtenances, pull and twist and turn to get the movement out before I can get to the hands. When the job is done a half-hour is gone. I sell the clock, warrant it for a year and make perhaps a dollar. Some I know are better than others, but there is not one that is not more bother than it is worth. Now, Mr. Editor, I don't expect you can remedy this evil, but if you can spare enough of your space to publish this in THE CIRCULAR it may lead to an agitation of a reform, or lead to some measures which shall lighten the burden of country dealers. Respectfully yours,

N. J.

HONEST MADE WATCHES.

To the Editor of the Jewelers' Circular:

I would like to call your attention to the new system introduced by the American Watch Co. of selling a complete watch in cases that are made to fit the movements, and of the quality represented by the stamp. As soon as the trade realizes the difference between honest goods at a fair price and the old way of selling the cheapest cases with the most *steal* in them, whether the movements fit or not, because they can be sold cheap, I am sure they will pronounce in favor of the standard article with responsible parties to fall back on in case anything is wrong. Respectfully,

E. A. T.

N. Y. City.

To the Editor of the Jewelers' Circular:

Your theory of a government stamp enables anyone who knows nothing about the business to sell and warrant his goods, because he uses the government stamp and has the same to back him. Where is there any show for the jeweler who has spent years and many dollars in learning his business and who makes and sells first-class goods? Give us more stamped goods made for jewelers only. School

your jobbers to be strictly honest and fair, and your manufacturers to make goods with a stamp or guarantee that can be relied upon, and then the jeweler who spends time and money in learning his business will have a show to retain it. The catalogue business is growing an intolerable nuisance, and ought to be abolished entirely—nothing but an additional expense on the price of goods is made by their circulation. Only a few days ago a wife of a dry goods merchant brought in a catalogue, with discount sheets and all in, of every article used by a jeweler, and wanted me to order a \$24 pair of bracelets at net price. I of course refused, consequently made no sale—but this did not prevent her getting them from the jobber direct. I think it would be a good thing for the manufacturers to start a Guild system of their own, exclusively in the interest of the jewelry trade, selling to such jobbers as comply with this rule.

Ind. J. B. K.

[Our correspondent evidently has not been a careful reader of our articles on the subject of the government stamp. According to our theory it simply compels manufacturers to make straight goods, and not to permit the representation of fourteen karat goods made out of ten karat gold. We would have all such goods confiscated, and held as evidence to convict the manufacturer of a criminal offence. The government stamp now affixed to a piece of silver makes it pass for a dollar, but such piece must conform to a specified standard of quality before the stamp will be placed on it. This is what we want to see in jewelry—a fixed standard of quality, and penalties for misrepresentation of quality. That is all we suggest in a government stamp. Under such conditions retail dealers would be certain of the quality of their goods, and would never jeopard their individual reputations by guaranteeing a fraudulent article, or become *particeps criminis* in a swindle on the public. A government stamp would put an end to the auction business, and to the sale by outsiders of cheap imitation goods, by means of which they now offer a dangerous competition to the retail trade.—ED.]

"THE CIRCULAR'S" INDEPENDENT COURSE.

A subscriber of twelve years' standing writes as follows: "I am surprised that, considering that the manufacturers and jobbers are your almost exclusive patrons as advertisers, you have succeeded in keeping such an independent and fair policy toward the retailer. As a medium for technical information the journal excels.

Wapakoneta, O.

H. M.

A RETAIL DEALER'S VIEWS.

To the Editor:

Permit me to congratulate you for the first article in the April number of THE JEWELERS' CIRCULAR, and for which every retail jeweler in the country should do the same. Everything in it from retailer to manufacturer is O. K. Let the good work go on, and long may THE CIRCULAR live, and its editor know no end to his riches, is the wish of your friend,

Waukesha, Wis.

A. F. E.

LYING AND DETRACTION IN BUSINESS.

To the Editor of the Jewelers' Circular:

There are some men in the trade who evidently act upon the theory that the only way to build themselves up in business is by pulling other people down. Lacking the brains and business tact to meet competition fairly and squarely, they resort to misrepresentation and positive lying about their neighbors and their neighbors' goods to steal away their trade. I have seen considerable of this among retail dealers, and not a little among the travelers for eastern houses. Only a few days ago a traveler on his southern trip stopped in this city, offering gold rings as his specialty. He called on me and showed his samples, but I informed him that I bought all my rings of a well-known house in New York that had always done well by me, and whose goods were always up to the standard represented. "Ah," said he, "you buy of Smith, do you? You pay him eighty-five cents a pennyweight, I suppose, for his eighteen karat goods?" I replied that I had always paid ninety cents for that grade of goods. "Ninety cents!" he exclaimed, "why I don't see why he should

charge you ninety when he sells all through the eastern cities at eighty-five." Now, such a statement as that, coming from the representative of a respectable house, very naturally staggered my faith somewhat in Smith. On inquiring of my neighbors I found that he had told the same story to all who bought their rings of Smith. We were all considerably exercised, for we had placed implicit confidence in the house of Smith, so we took pains to ascertain whether this report was true or not. The result of our correspondence with New York and Boston retailers was that we ascertained that Smith universally charged ninety cents for his eighteen karat goods, and that we in Baltimore were on the same footing as dealers in New York, Boston or Chicago. Of course, our faith in Smith was restored, while the stock of the lying traveler fell considerably below zero, and it is safe to say that he will never sell a dollar's worth of goods to anyone in this city to whom he made these false statements. Having lost confidence in him, we should have none in his goods. I cite this recent case simply as an illustration; I have encountered many other persons who sought to obtain trade for themselves by misrepresentation and detraction. As a retail dealer striving to carry on an honorable business in an honorable way, I protest against such discreditable methods. They disgust me and make me ashamed of the humanity that will stoop to such dirty tricks. My motto is "live and let live;" I do not fear competition that is fairly conducted, but I will be no party to deceit and fraud. Has commercial honor departed from us that it is permitted to man to make falsehood and detraction their stock in trade? There are many tricks and devices resorted to by unprincipled men in our trade that should be held up to the scorn and contempt of every honest man in the land.

Baltimore.

JUSTICE.

Cautioning Retail Dealers.

IN RESPONSE to a circular sent out to the retail trade under the auspices of the Jewelers' Protective Union, relative to the adoption of measures for the protection of retail dealers from robbery, numerous responses have been received by the president of the Union, thanking them for their consideration, and generally approving of the plan. The following are sample letters:

Your warning from the Jewelers' Protective Union is at hand, for which I am very thankful, as I have been robbed twice in this place since 1862, but not molested any more of late years, as I have a fine burglar-proof safe with combination and time lock, a good double-barrel shot gun and Sharp's carbine rifle at my bench and in sight. Revolvers and repeating rifles at every nook and corner, one small cannon, as well as hand grenades, shots and shells selected; beside all that precaution, reside with my family back of my store and shop, and sleep with my other half, who keeps me from snoring too loud, and is a good hand with a rolling pin, though only 23 years old, but active, and able to hoist out such hard customers by the seat of their breeches in the street or down in the cellar through a trap door, before they can say Amen. Now let your cracksmen take warning. On the other hand, I wish to inform the wholesale jewelers and others, through your well-meaning Association, to be more careful who they send circulars and price lists or goods on time, as a retail dealer who pays for his goods cannot compete with Tom, Dick and Harry, who never, yes, hardly ever, pay for goods, and are no cracksmen, either.

Rolla, Mo.

G. W. S.

WM. R. ALLING,

President N. Y. Jewelers' Protective Union:

The Union circular warning jewelers to guard their stores has been received by us. On February 4 our store was entered, safe drilled and robbed of about \$8,000. We caught two of the burglars, some two weeks after. Recovered a small amount of property and have a reasonable chance to get more, and two other thieves. The ring-leader of this party was Gilbert Yost, an old New York and Brooklyn crook, formerly an associate of Draper, Porter and Irving, known in Brooklyn as the Patchen avenue gang. Yost is now in jail here, has pleaded guilty, and is awaiting sentence. His permanent address for the next fourteen years will be, "Northern Indiana Prison, Michigan City, Indiana."

Yours truly,
La Porte, Ind., March 19.

EDWARD VAIL & SON.

The Mayor of Austin, Texas, having seen a copy of the circular, writes for photographs of any well-known thieves who are now "on the road." This is impossible, as the police of this city are not permitted to send out pictures from "Rogues' Gallery," or even to exhibit them in public. They are kept for the private use of those who are seeking criminals.

May Removals.

Carter, Sloan & Co., from 694 Broadway to.....15 Maiden Lane.
 Waterbury Watch Co., from 4 to.....52 Maiden Lane.
 Mabie, Todd & Bard, from 180 Broadway to
 the.....Bryant building, cor. Liberty and Nassau streets.
 Henry Carter, from 176 Broadway to the.....Bryant building.
 Courvoisier, Wilcox & Co., from 12 Maiden Lane
 to the.....Bryant building.
 Charles Glatz, from 10 Maiden Lane to the.....Bryant building.
 Dueber Watch Case Mfg. Co., from 16 Maiden
 Lane to the.....Bryant building.
 Ketcham & McDougal, from 4 Liberty Place
 to the.....Bryant building.
 Isaac A. Alling & Co. will open an office in the....Bryant building.
 Goldsmith & Kuhn, from 66 Nassau to.....33 and 35 John street.
 Leopold Weil & Co., from 16 to.....35 Maiden Lane.
 Noah Mitchell from 694 Broadway to....52 Maiden Lane.
 Leroy W. Fairchild, from 1 to.....18 John street.
 Traitel Bros., from 170 Broadway to.....40 Maiden Lane.
 A. Bantle, from 79 to.....89 Nassau street.
 George A. Eaton & Co., from 15 to12 Maiden Lane.
 Krementz & Co., from 192 to.....182 Broadway.
 Rest Fenner Smith & Co., from 4 Great Jones
 street to.....710 Broadway.
 Lincoln & Bacon Manufacturing Co., from 15 to..12 Maiden Lane.
 Yale Clock Co., from 4 to.....52 Maiden Lane.
 G. A. Wolf, from 35 to.....65 Maiden Lane.
 L. F. Cahn, from 16 to.....12 Maiden Lane.
 S. Kohn & Co., from 15 John street to.....43 Maiden Lane.
 E. L. Anrich, from 25 Maiden Lane to.....182 Broadway.
 Maass & Schraeder, from 35 to.....65 Maiden Lane.
 H. Schnurbusch, from 3 Maiden Lane to.....104 Nassau street.
 Ph. Korn, from 28 Bond street to.....63 Nassau street.
 Samuel Lawson, from 63 Nassau street to.....18 John street.
 Jacob Strauss, from 18 to.....25 John street.

CHICAGO.

Robbins & Appleton, from 170 State street
 to.....Jeweler's Exchange building, 100 and 102 State street.
 Giles, Bro. & Co., from 33 and 35 Washington
 street to the.....Second Floor of 101 and 103 State street.
 Eureka Show Case Co., from 135 Wabash avenue
 to.....48 and 50 Lake street.
 B. F. Norris & Co., from 105 and 107 State street
 to.....29 Washington street.
 Fred. Blauer, from 182 State to.....Jeweler's Exchange building.
 J. & F. M. Solomon, from 150 to.....105 State street.
 F. E. Morse & Son, from 69 Washington street
 to.....Jewelers' Exchange building.
 Hagstoz & Thorpe, Chicago branch, from 67
 Washington to.....Jewelers' Exchange building.

The Jewelers' Security Alliance.

THE MOVEMENT heretofore reported in these columns for securing better protection for the retail dealers against thieves and burglars, has at last assumed definite form. Several meetings of prominent members of the trade have been held, and, after full discussion of the subject, it was resolved to form an organization, to be known as "The Jewelers' Security Alliance of the United States. At a meeting held April 25, the following Constitution and By-Laws were adopted:

PREAMBLE.

Owing to the frequent robberies of Jewelers' Safes, and the urgent necessity of combined effort to prevent such burglaries, we, members of the Jewelry trade of the United States, deem it essential to form an Association for that purpose, and agree to adopt the following Constitution and By-Laws:

CONSTITUTION.

ARTICLE I.

Name.

This Association shall be known as "The Jewelers' Security Alliance of the United States.

ARTICLE II.

Object.

The object of this Alliance shall be to render to its members, whose safes may be robbed, efficient detective service and *determined* prosecution of the thieves, aiming at the restoration of the property when possible.

ARTICLE III.

Location.

The headquarters of the Alliance shall be in New York City.

ARTICLE IV.

Officers.

The Officers of this Alliance shall consist of a President, Vice-President, and Treasurer, and an Executive Committee of *Six*, and the President, Vice-President, and Treasurer shall be members *ex-officio* of the Executive Committee.

ARTICLE V.

Membership.

SEC 1.—Any person or firm regularly engaged in the Jewelry or kindred trades, may become a member of this Alliance, whose application shall be approved by the Executive Committee.

SEC. 2.—The membership fee shall be ten dollars, and the annual dues five dollars.

SEC. 3.—All applications for membership must be accompanied by ten dollars as membership fee, and five dollars annual dues, which sum will be returned if the application is rejected.

ARTICLE VI.

Annual Meetings.

The annual meetings of this Alliance shall be held on the first Tuesday in May of each year for the election of Officers and Executive Committee, and for the transaction of such other business as may come before the meeting.

ARTICLE VII.

Amendments.

This Constitution may be altered or amended by a vote of two-thirds of the members present at any annual or special meeting, at least thirty days' previous notice having been given to the Executive Committee.

BY-LAWS.

ARTICLE I.

It shall be the duty of the President to preside at all meetings of the Alliance, and in his absence the Vice-President shall preside and perform all other duties of the President.

ARTICLE II.

It shall be the duty of the Treasurer to receive and take charge of all moneys paid into the Alliance, and to safely invest the same under the direction of the Executive Committee and disburse in the same manner. He shall make a report to the annual meeting, and at least quarterly to the Executive Committee, and at such other times as they may direct.

ARTICLE III.

All disbursement of moneys over and above the sum of twenty dollars shall be by check, signed by the Treasurer and President of this Alliance.

ARTICLE IV.

It shall be the duty of the Executive Committee to employ a competent person as Secretary of the Alliance.

ARTICLE V.

Election of Officers.

At the first election of the Alliance a President, Vice-President, Treasurer, and three members of the Executive Committee shall be elected for the term of *one* year, and three for the term of *two* years, and the persons receiving the highest number of ballots for each or either office shall be declared elected.

At every subsequent annual meeting of the Alliance, in like manner, election shall be held for officers whose terms of office at that time expire, and for vacancies in office, if there be any, excepting that the persons elected as members of the Executive Committee, in the places of those whose terms of office at that time expire, shall be elected for the term of two years.

ARTICLE VI.

It shall be the duty of the Executive Committee to prescribe the forms of application for membership, to direct the Secretary in the discharge of his

duties, and to exercise a general supervision of the business of the Alliance, and to furnish a full report of their actions to the regular annual meeting, or to any special meeting when required.

ARTICLE VII.

The Executive Committee shall have power to call a special meeting of the Alliance and employ such agencies as they may deem best for the protection of its members and the furtherance of the object of this organization.

ARTICLE VIII.

In case of a vacancy occurring in the board of officers of the Alliance, the Executive Committee shall have power to fill the same until the next annual meeting of the Alliance.

ARTICLE IX.

In case of necessity the Executive Committee shall have authority to order an assessment not exceeding five dollars at any one time.

ARTICLE X.

Under no circumstances shall the funds of the Alliance be used for the purpose of compromise with thieves.

ARTICLE XI.

No member shall be entitled to the benefits of this Alliance, except his certificate of membership is conspicuously displayed at his place of business therein described.

ARTICLE XII.

Any member in default of payment of his annual dues, or an assessment ordered by the Executive Committee, for the term of thirty days, after due notice of the same, shall cease to be entitled to any further benefits from this Alliance, and shall be requested to return his certificate of membership. A notice sent to the last address given shall be considered a legal notification. Any member may be reinstated at the option of the Executive Committee.

ARTICLE XIII.

In case of the dissolution or change of any firms represented in this Alliance, due notice shall be given to the Secretary by the legitimate successor or successors of said firm, and they shall be entitled to the privileges of the Alliance, subject to the approval of the Executive Committee.

ARTICLE XIV.

If at any time the Executive Committee should deem it advisable, they shall have the power to appoint an Advisory Board (and defining their duties) of such numbers and in such cities as they may think best.

ARTICLE XV.

The Alliance cannot be called upon by its members for protection in case of robbery, except when their safe or safes may have been robbed during the hours when the place of business is closed.

ARTICLE XVI.

These By-Laws may be suspended, altered or amended at any regular meeting of the Alliance, by a two-thirds vote of the members present.

In accordance with the By-Laws above given, the following named gentlemen were elected officers for the coming year: D. C. Dodd, Jr., President; A. K. Sloan, of Carter, Sloan & Co., Vice-President; P. T. Tunison, of Hodenpyl & Tunison, Treasurer; the Executive Committee is as follows: C. B. Bishop, of Carrow, Bishop & Co., C. G. Alford, of C. G. Alford & Co., Henry Hayes, of Wheeler, Parsons & Hayes, J. B. Bowden, of J. B. Bowden & Co., David Untermeyer, of Keller & Untermeyer, and E. F. Dorrance, of Dorrance, Edge & Co.

At the meeting there were over twenty applicants for membership, and from the interest the trade has evinced in this movement, it is evident the Alliance is regarded with great favor and as a necessity. It is solely in the interests of the retail dealers, for in case of the robbery of any member, the cost of pursuing and prosecuting the thieves and recovering the goods will be borne by the Alliance, and not left as an additional burden upon the shoulders of the victim of the robbery at a time when he can least afford such expenditure. We commend the action of the Alliance to the careful consideration of our readers, and would recommend all retail dealers to become members. For the present, communications may be addressed to THE CIRCULAR.

Obituary.

J. T. Scott, of the firm of J. T. Scott & Co., one of the prominent jobbing firms of this city, died at his residence in Brooklyn on the 22d ult., in the 59th year of his age. Deceased was born at Huntingdon, Pa., where he first engaged in the jewelry business. He then removed to Wheeling, West Virginia, where he carried on an extensive jewelry business for fifteen years. He next located at Pittsburg, Pa., in consequence of his rapidly extending business, which continued to expand until he found it necessary to establish himself in New York, which he did in 1868. His business methods have always been characterized by energy, enterprise and integrity, and he soon gained a wide popularity in the trade. The name of J. T. Scott will prove to be a valuable passport to success in behalf of his sons, who are already identified with the business. Personally Mr. Scott was a most estimable man, genial, kind hearted, affable, and benevolent. All who had dealings with him learned to have the utmost confidence in him. His loss will be deeply regretted by the entire trade, and by a large circle of devoted friends in the social circles in which he moved. Mr. Scott has long been a sufferer from that insidious disease, consumption. He leaves a widow and several children. His remains were taken to Huntingdon for interment in the family burying ground.

The Diamond Country in Africa.

THE SOIL, when brought to the summit, is carted away and strewn on the ground, where it is left for a fortnight or three weeks to pulverize in the sun. At the expiration of this time gangs of Kafirs, superintended by a white overseer, break the large, dry lumps into powder, and this in turn is carted away to be placed in the washing machine. It is during the process of first breaking that some of the largest diamonds are discovered, and the overseer has to keep a sharp look-out on the workers in consequence. In spite of the terrible penalty incurred by anyone detected in the act of secreting a good find, thefts are very rife, and many a diamond finds its way into Kafir possession in spite of the sharpest vigilance. During the process of washing, the gravelly substance, which is full of garnets as well as the diamonds, sinks to the bottom of the machine, while the earthen substance disappears in another channel. When it has been thoroughly washed through two or three times this gravel is collected and strewn on tables, where searchers, with steel instruments somewhat resembling very broad knives, carefully turn it over in minute search. Then it is that the precious jewel is discovered in all manner of sizes and shapes, when it is placed in a small tray, on which another overseer keeps his watchful eye. I was given several little heaps of gravel to dissect, and in half an hour had succeeded in discovering about 20 or 30 diamonds of very fair size, and some so perfectly shaped that they had every appearance of having just left the cutter's hands.—*In the Land of Misfortune—Lady Florence Dixie.*

AT THE recent meeting of the British Association, Mr. Barlow read a paper "On the Mechanical Properties of Aluminum." This metal is used chiefly as a substitute for silver, but the author had found it to be exceedingly strong in proportion to its weight. Experiments had been carefully made for him by Prof. Kennedy, from which its valuable properties of ductility, tensile strength, and elasticity were fully demonstrated. This was well illustrated by the comparative length of rods of uniform section, but of different metals, which could be suspended without rupture, the lengths in the case of steel and aluminum being equal and exceeding all others. Unfortunately it is an expensive metal, and the process by which it is at present extracted leaves little hope of its use being greatly extended. Sir H. Bessemer said he did not think any metal could be depended on like the one in question, from the small part its weight took in producing its rupture. He exhibited a key of the material (about the size of a large latch key), and it was stated that forty-five of these would only weigh one pound.

The Triplex Escapement.

[From the *Allg. Journ. d. Uhrmacherkunst*].

THE TRIPLEX escapement pertains to the class of free or detached escapements, by which the balance, after having received an impulse, continues its motion free, as in the anchor escapement, etc. It is a chronometer escapement with impulse at each vibration, while the ordinary chronometer escapement receives an impulse only at each second vibration, the intermediate one being without impulse.

For solving the interesting problem of constructing a chronometer escapement with impulse toward both directions, belong three wheels sitting firmly upon the arbor of the scape pinion; two impulse wheels (each with 10, 12, 15, etc. teeth), and a detaining wheel with double the number of teeth (20, 24, 30, etc.); a simple detent is also necessary, represented by *d* in the diagram.

Figs. 1 and 2 represent the action of the escapement in two consecutive vibrations; fig. 3 shows the manner of drawing the escape-

ment when the diameter of the small scape wheel is given. Fig 4 gives the elevation and cross section of the escapement parts; fig. 5 the detent, and fig. 6 the lower potance in different situations.

must, by various turnings, be formed so that the lower balance pivot is located securely between the two escape wheels. The action of the escapement is easily to be understood by studying figs. 1 and 2. In fig. 1 the balance vibrates from left to right, the unlocking pin *i* is on the point of liberating the detaining tooth *n*⁴, after which the tooth *a*¹ of the small impulse wheel works with 5° drop upon the impelling plane of *b*. Impulse having been given, detaining tooth *n*³ applies itself upon the detaining plane *v* of the detent, and the balance continues its vibration until the increasing tension of the spring causes it to return; in fig. 2 this motion from right to left is represented at the moment when the unlocking pin *i* is about to liberate the detaining tooth *n*³, so as to impart, after a drop of 5°, an impulse of the tooth *c*¹ upon the lifting plane of the large impulse roller *e*. When the impulse has been imparted the balance continues its motion, in order to again receive afterward an impulse according to fig. 1.

For constructing the escapement several data may be given; the distance of the line of centers *p q* (fig. 3) of the operating parts, or

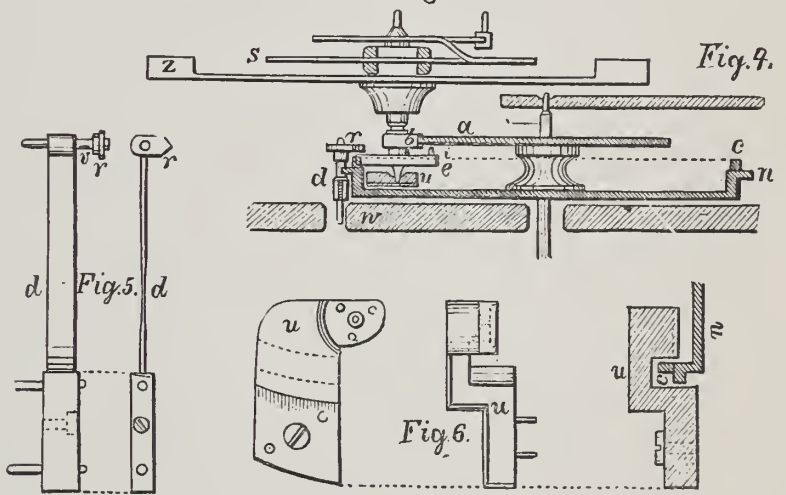
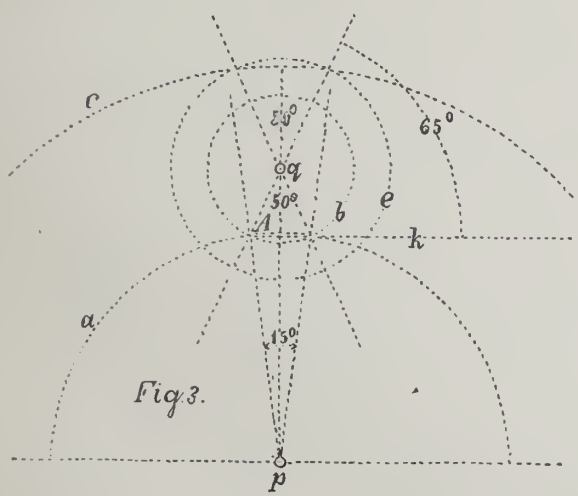
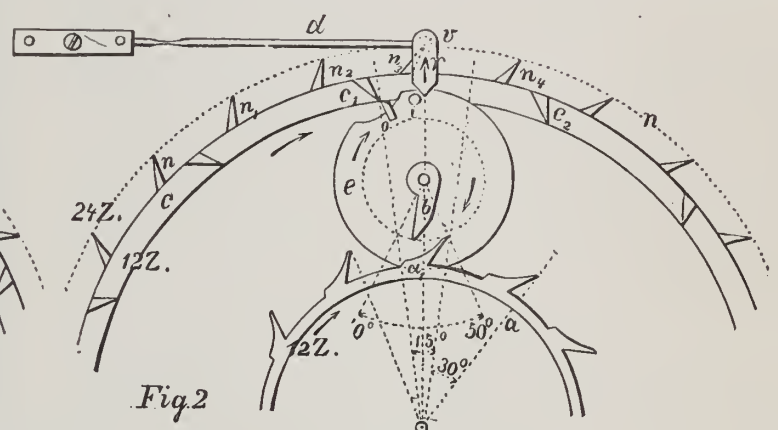
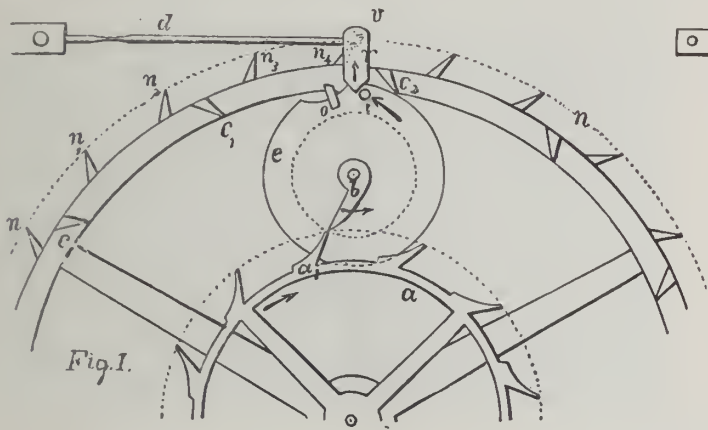

ment when the diameter of the small scape wheel is given. Fig 4 gives the elevation and cross section of the escapement parts; fig. 5 the detent, and fig. 6 the lower potance in different situations.

The outer or large impulse wheel *c* has here 12 vertical teeth, *c*¹, *c*², etc.; it has a deep groove, so as to clear the potance *u*. On the circumference of the large impulse wheel are situated the detaining teeth *n*, *n*¹, *n*², *n*³, of the detaining wheel with 24 teeth. Above the large impulse wheel *c* *n* comes the small or inner impulse wheel *a* with 12 teeth; this seizes into the impulse pallet *b*, while the large impulse wheel operates upon pallet *o*, fastened in the impulse roller *e*. From the large impulse roller *e* vertically protrudes the unlocking pin *i*, which strikes alternately upon each of the beveled faces of the tooth *r* of the detent; below *r* is the detaining place *v* for the teeth of the detaining wheel *n*. The detent *d*, after each unlocking, returns into its former position; the angular motion of *d*, in the direction of the wheel, is limited by the plate *w*, as will be seen by fig. 4; *z* represents the balance, and *s* its spring. The potance *u*

the diameter of the large impulse wheel *c*, or that of the small one *a*, may be given. When the distance of the line of centers *p q* has been given, the solution is easiest, because after the impulse angles (here 50° and 15°) have been established the radii of the points of intersection determine the radii of the circles *a* and *b*.

If we assume that only the diameter of the small impulse wheel with 12 teeth be known, and the lifting of the balance is to amount to 50°, it becomes necessary first to ascertain the one-half of two tooth points, because the angular motion of the wheel during impulse is equal to one-half of this distance; exactly opposite to the center of two teeth of the small impulse wheel lies a tooth of the large impulse wheel. By 12 teeth the space between two teeth is equal to 360 divided by 12, or 30°; the one-half, 15°, is set out at 7½° to both sides of the center line *p q*, the radius of the small impulse wheel (30 mm. in fig. 3) was known. The intersecting points of both the radii, inclosing the angle of 15°, are joined by a prolonged line *k*. Now, in order to obtain a balance impulse of 50°, an angle

of 65° must be marked off at *A* upon the line *k*, where the second line intersects the line of centers, at *g* is the center of the balance. If also the balance is to receive an angle of impulse of 50° from the large wheel *c*, the limbs of the angle of 50° are prolonged toward the opposite side, and the dimension of roller *e* or of the wheel *c* may be chosen at option; as soon as the size of one has been accepted the other one may be at once determined therefrom. In figs. 1 and 2 the lifting upon the large roller has been taken exceeding 50° by a trifle.

We have to thank Mr. Moritz Grossmann for the publication of the triplex escapement. The escapement is probably of American origin, since this gentleman obtained the first specimen from San Francisco. Owing to the direct impulse communicated at each vibration, such watches vibrate strongly, and cannot be easily set, a property not shared by the simple chronometer escapement.

F. ROSENKRANZ.

Galvano-Plastic Art.

BY EXPERT.

ARTICLES of solid silver can be cast readily by electro deposit, and in some cases it can be done to advantage. The solution to be used is the ordinary cyanide solution, and the application will suggest itself to the reader. Open work articles, like card cases and card receivers, and a thousand and one artistic novelties can be produced in this way. The moulds are made in wax precisely as directed for the copper deposit. A double deposit can be made on a wax mould, made as described in former article, by rendering only portions of the mould conductive at a time. If, for instance, you wish to surround a group in copper by a silver wreath; the wreath is first made conductive by black leading, and the silver is cast on this. The whole mould is afterward coated with black lead, and then the copper is cast on. The copper, of course, is deposited over the silver; but on removing the wax the silver is exposed to view above the copper. A beautiful finish is given to copper electro-relief work by first bronzing it in dark bronze, as will be hereafter described, and after the dark bronze surface is produced, rub the higher and more prominent substances with the preparation, and in the manner described. Dissolve gold in nitro-muriatic acid, and dip linen rags in the solution until all the solution is taken up; let the rags dry, and when fully dry, burn them on an earthen plate. A bit of woollen cloth, moistened in a solution of sal ammoniac (muriate of ammonia) and dipped in the ashes spoken of above, and rubbed on the prominent portions of the bronzed relief work, instantly take on a beautiful gold color, which will neither fade nor tarnish, as there is an actual coat of gold given to the copper. The dark bronze color to such electrotype panels as have been described, can be given in a variety of ways. Gradual heating after thorough cleansing will give a fine brown bronze. The cleaning can be effected by washing with a solution of common sal soda, and finally with a weak mixture of nitric acid and water, then rinsing in pure water and dry with a soft napkin. The heat should be applied gradually and evenly until the desired brown tint is obtained. A dark bronze is obtained by washing over the surface with a weak solution of sulphuret of ammonia, rinsing, and drying with a soft cloth, and afterward apply gentle heat. Green bronze is obtained by exposing the panel to the vapor of bleaching powder (chloride of lime). But, in the judgment of the writer, nothing finer can be obtained than to wash the surface of the panel with a weak solution of platinum dissolved in nitro muriatic acid, and then touched up with the gold ashes as above described. Perfect *fac similes* of old copper and silver coins can be made by electro deposit as follows: Turn a recess in a piece of sheet brass so as to receive one-half of an old (or new) coin. The brass should be quite thick, No. 8 or 10, using the thickest for the largest coins. In fig. 1 is shown a plate of brass at *B*, and at *a*, the coin lying in the recess; *A* is an edge view of same. If a piece of gutta percha is put for a few minutes in boiling water, it becomes plastic, and by applying another plate of brass like *B* (except the recess) and putting the two pieces into a vise as shown at fig. 2, and screwing the jaws together, a fine impression of the side of the coin exposed will be produced in the gutta percha. The brass plates should be heated to the same degree (boiling point) as the gutta percha. The brass plates should not be loosened from the vise until quite cold. A more perfect apparatus is shown at fig. 3; in this arrangement the gutta

percha is shown in section at *h h*, and compressed by a follower shown at *j*. The lower plate *g*, fig. 3, is recessed for the coin as shown in fig. 1, but is also turned away so as to leave a projection on which the ring *h* is forced; by forced I do not mean driven on, but to fit tight enough to hold it in place. The follower *j*, is secured in a recess in the upper plate *f*, and can be (if necessary) secured with a little soft solder. The follower *j* should fit easily into the ring *h*. In using this arrangement the coin should be placed as shown at *i*, and both plates heated up to 212° F. (dipped in boiling water), and a piece of gutta percha large enough to half fill the recess *c c*, after softening in boiling water. Pressure can now be applied to the plates *f* and *g* in a letter-copying press or a bench vise, as shown. As the ring and follower prevents the gutta percha from spreading and "dodging," a perfect matrix of the coin is obtained, even to accidental scratches—so perfect is this process. The gutta percha mould will readily take a black lead coating, and surround it with a copper wire as shown at fig. 5, it is ready for the sulphate of copper bath. A few details will be necessary. After the gutta percha mould is pushed out of the ring *h*, the wire *k* is passed around and joined by twisting, leaving a ring for hooking on to battery wire; the face is now coated with black lead, letting the black lead coat

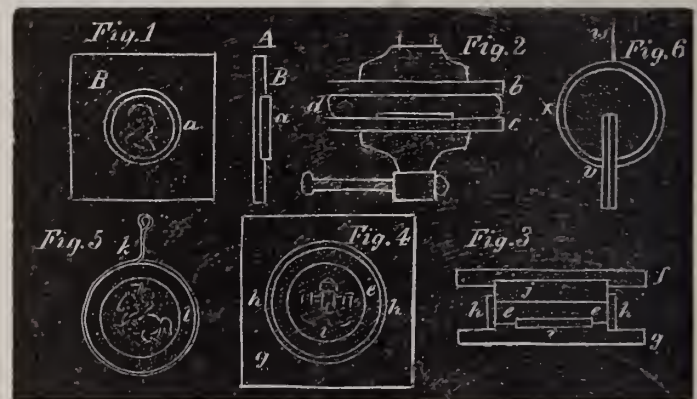

extend to the wire *k*, to ensure conduction. On putting the mould into the sulphate of copper bath, already described in former number, and connecting the battery, a bright film of copper will soon extend across the face of the mould, but as it is desirable to deposit any amount of copper except into the matrix of the coin, after a perfect coat of copper is established, all the surface of the mould (now coated with copper) outside of the coin's impress, can be painted over with shellac dissolved in alcohol. After the shellac coat is dry, the mould can be returned to the battery, and no deposit will be made except on the coin's matrix. The deposit should be continued until sufficient copper is deposited to be equal to a trifle thicker than one-half the coin. Of course the reader will see that there must be a gutta percha mould made for each side of the coin. After the two halves are made and removed from the gutta percha moulds, which is done readily without any injury to the mould; the backs or rough sides of the deposits can be filed or turned off, and the surfaces made to fit back to back by grinding so perfectly, that an atom of soft solder the size of poppy seed will join the halves with only the hint of a line or joining between them, and a slight rubbing with a burnish effaces this. A better but more troublesome plan is to grind the backs as described after first coating the faces with shellac dissolved in alcohol; this process covers both faces and edges perfectly to the ground surface. If now the two halves are clamped together with a springy metal ring as shown at fig. 6, where *r* represents the two halves, and *x*, the ring; *w* shows the wire connecting to the pole of the battery. The ends of the clamp *x* should touch the metal surface of the coin—a little turning back and forth will ensure this. The ring should now be coated with shellac, especially where the ends touch the shellac coat on the coin. By careful management even milled-edged coin can be joined so as to defy the magnifier—the edges should be matched exactly. The two halves of coin should now be hung in the sulphate of copper bath, and the current passed through, when in a short time the two halves will be perfectly joined by electro deposit between the two halves. Remove the coin (now made one), and as soon as the joint is filled up take it out. In this way a *perfect fac simile* of the original coin is produced, the only defect being in the ring, the produced (we can hardly say counterfeit) coin being "dumb," as it is technically termed. Silver coins can be produced in the same manner, only requiring more time and care. Electrotyping of wood cuts is simple, and can be made useful to the trade as will a system of relief engraving suitable for printing in a type press, and will receive our attention next.

Proceedings of the Horological Club.

A DISTINGUISHED BODY OF WATCH AND CLOCK MAKERS.

Our hundred and seventh Discussion.—Communicated by the Secretary.

[NOTICE.—Correspondents should write all letters intended for the Club separate from any other business matters, and headed "Secretary of the Horological Club." Direct the envelope to D. H. Hopkinson, Esq. Write only on one side of the paper, state the points briefly, mail as early as possible, as it must be received here not later than the eighth day of the month, in order to be discussed and reported in the CIRCULAR for the next month.

ELECTRIC BURGLAR ALARMS.

Secretary of Horological Club:

I am building a new store and am putting in burglar alarms. Have two vibrating bells with powerful Leclanché battery, door and window springs, from Tillotson & Co., New York. Am ceiling the store and putting the wires behind the ceiling. The clerk sleeps in the store; will have one bell in his room, and one in my bed room at my residence. Is such an arrangement considered perfectly safe? Do burglars usually avoid buildings that are known to contain alarms, or do the "professionals" have some way to overcome that difficulty? Is it best to keep the matter a secret, or let it be known that the building has alarms? M.

Mr. Electrode replied that no arrangement is perfectly safe. They are simply attempts to secure safety, and should be used in connection with constant watchfulness, but not allowed to lead to any lessening of care in other ways. Electric devices are very valuable, but they all have the weak point that any defect in the connections or any break in the circuit renders the whole system useless. Mr. M. will appreciate this point better by making the experiment of putting a piece of tissue paper between the two parts which are intended to come in contact and set off the alarm. He will find that no alarm will be given. Even a hair, a little fuzz, a coating of dust, or anything which prevents good metallic contact, will prevent the current passing through, and consequently prevent the bells ringing. The springs which press together must therefore be constantly watched to see that the surfaces are clean and free from rust, and that they meet properly, so that the current can pass readily. The connections of the wires at the batteries must be clean and unmistakably tight. This is one bad feature about the Leclanché battery. Although it is probably the best battery for such uses, the screws are apt to work loose and fail to pinch the connecting wires. The safest way is to soft solder the wires to the tops of the zincs, and flat them where they go under the nuts of the carbons, then occasionally try the nuts to be sure that they are tight. If the connecting wires are spliced anywhere, they should first be lapped for half an inch, then well twisted together, and finally soft-soldered, so that the ends can neither part nor get rusty where they press each other. This precaution is especially necessary to be observed when the wires are not in sight, but covered with ceiling or plastering.

In addition to having everything right at the start, and frequent examinations of the connections and springs, it is well to make an actual trial every night at closing, to see whether the alarm works properly. As regards professional burglars, they do not avoid anything if there are valuables worth going for. They generally make themselves familiar with the premises, and the different safeguards employed by inspection in the day time, so that the more secret and invisible every part is kept, the better. Otherwise they may discover some place where they can cut a wire, or bend a spring, to render the circuit useless before attempting an entrance. All such parts should be so arranged that they cannot be reached from the outside nor interfered with except by some one already in the store. Then, if everything is in order, illicit entrance will, of course, be impracticable.

BOTTUM'S HAIR-SPRING GAUGE—HARD-SOLDERING DIAMOND RINGS WITH THE STONES IN.

Secretary of Horological Club:

Will a member be kind enough to inform me how Bottum's hair-spring gauge is used? Also, is there any danger of cracking or injuring a large diamond when hard-soldering one of the clamps or

catches of a ring setting, without taking the diamond out? You know occasionally one will break or wear off, and it is a hard job to take the stone out, thereby breaking, perhaps, some more off by bending up, and would be considerable easier could it be soldered on leaving the diamond in. J. D. H.

Mr. Rolliver believed that the method of using the Bottom hair-spring gauge was described at our last month's meeting, and could be found in the Proceedings.

As regards the hard-soldering of rings with the stones set in, there is danger of cracking it, if heated or cooled unequally, or too suddenly. The diamond will stand a good deal, if carefully done, but there is always a risk, and it is generally advisable to remove it when the flame has to be blown upon it, or very near to it, unless the workman has experience enough to know whether it is safe, in such case, to leave it in. With respect to other claws breaking off, the owner can be told of the possibility of such an occurrence, and that a small further charge would have to be made for restoring them. Wearers of diamond rings should be able to pay properly for repairing them—and if not willing to do so, the workman had better decline the job. It is no part of his duty to take risks for his customers, nor to work without pay. All he is required to do is to possess proper skill, and to use reasonable judgment and care. Any breakages which are due to the construction or condition of the articles, and could not be avoided or prevented by ordinary skill and care, are properly chargeable to the owner—not to the workman, who has done all that could be done to avert them. Still, it is well to have such matters understood beforehand, unless the charge was made sufficient to cover all breakages likely to occur.

MAINSRING BROKEN IN 32 PIECES—THE CAUSE.

Secretary of Horological Club:

I see by the last CIRCULAR a communication regarding a mainspring breaking in eleven pieces; also, that you had known of a spring breaking in twenty-four pieces. I can go you eight pieces better—which pieces I enclose, taken out of a P. S. Bartlett watch. But I do not think it is a Gravier spring. It was broken in almost a straight line across. Thinking the Club would like to know of this, I send you the item. J. W. R.

Mr. Clerkenwell said that Mr. R.'s specimen was certainly a little the finest broken spring he had seen. He had observed that mainsprings were very apt to break after being cleansed in benzine, benzole, naphtha, ether or alcohol, and possibly this spring had been allowed to soak for some time in some liquid for taking off the grease. Mainsprings should not be cleaned by chemical means, but by carefully wiping off with thin dry paper or a clean cotton rag, in such a way as not to bend the spring or straighten the inner coils.

We would be pleased to know if this spring was cleaned chemically, and wish that others who report broken springs would inform us on this point at the same time. If it is really a common cause of springs breaking it should be generally known by the trade.

BACK NUMBERS OF "THE CIRCULAR" FOR EXCHANGE—ISOCRONAL VIBRATIONS OF THE BALANCE.

Secretary of Horological Club:

In the October Proceedings of the Club, it is proposed that anyone willing to part with their set of CIRCULARS should address the Club, with price. I have some fourteen numbers, most of which have Excelsior's articles on toothed gearing. I don't wish to sell them, but want to exchange them for the "Treatise on the Balance." A second hand copy would do, if entire. Were it not that I expect to get them again when republished in book form, I would not part with them for any consideration whatever. No writer, so far as I have seen, can compare with Excelsior on watch repairing—so plain and easily understood. He knows how to tell what he means. There is one point, though, on which I should like the opinion of the Club. A writer in a former Proceeding claims to quote from the "Treatise on the Balance," to the effect that the time of a vibration of the balance depends on its extent, demonstrates it, and wonders how anyone could think otherwise. Now it appears to me that this is directly contrary to the doctrine of isochronism, or the performing of all vibrations, long or short, in equal times. Yet I infer from the title of the work that Excelsior explains the adjustment for isochronism. Cross Creek, Pa. Respectfully, W. H. REED.

Mr. Isochronal responded that what was meant was that vibrations of the balance are not necessarily performed in equal times. They may, or may not be. As a matter of fact, larger vibrations may occupy either more or less time than smaller ones, according to the length, coiling and stiffness of the spring, and its proportion to the balance, etc. And the adjustment for isochronism consists in adjusting all the parts so that all the vibrations, although unequal in extent, *will* be performed in equal times. This is often a very complex and tedious operation, and requires a skill possessed only by few. Excelsior's "Treatise on the Balance Spring, and the Adjustments for Positions, Isochronism, Heat and Cold, and Rate," gives such full and explicit instructions on every point, that any intelligent and skilful workman can learn to do it. It is in fact about the only work which does really give sufficient information of a practical nature to be of any value to the workman at the bench. As for the clearness of his writings, Mr. Reed only echoes the universal verdict, that it is unsurpassed in horological literature.

As the adjustment for isochronism is too large a subject to be discussed at length in our Proceedings, we publish Mr. R.'s letter, to aid him in exchanging his back numbers of THE CIRCULAR for the Treatise, in which he will find all the details he can need. If he cannot get anyone to exchange, he can obtain the book by mail from D. H. Hopkinson, Esq., at the office of THE CIRCULAR, for \$3.50, postpaid. It is therefore only necessary here to add that Excelsior does not state, as the doctrine of isochronism, that all vibrations are performed in equal times, but that by proper means they can be made very nearly isochronal when they do not vary in their extents beyond certain limits. That is to say, a spring is never *perfectly* isochronal, but it can be made to come wonderfully close—so close, in fact, that for all practical purposes it may be called free from error, since the error will be less than those arising from other unavoidable causes, as jarring, irregular winding, dirt, etc. The majority of watches called "adjusted for isochronism" do not come anywhere near that point, however, as the dealer will find on testing them, which any good workman can do by following the directions in Excelsior's Treatise. Should Mr. R. fail to find in it the information he wants, on any point, we shall be glad to explain it for him—but think it extremely unlikely that he will discover any such omission, as the work has been a standard and acknowledged authority on its subjects, for many years.

HALL'S MATERIAL CASE.

Mr. Ruby Pin exhibited a new "notion," in the way of a case for keeping any kind of small materials in, made by the irrepressible Hall Manufacturing Co. It is of wood, having fifty-five little cavities of various sizes cut in it, with the number of each hole stamped at its side, while the inside of the cover bears a printed index, with space for the name of the contents of each cavity, with its number. It is evidently intended to be sold low, although he was not informed of its price. Altogether it is an ingenious little device, and will be found very handy by almost everyone.

PROOF OF THE REVOLUTION OF THE EARTH—QUEER "STRIKE" OF DANISH WATCHMAKERS.

Secretary of Horological Club:

The observation has for a long time been made on railroads with main direction from south to north, or those which largely deviate from an east and west direction, that the locomotives chiefly jump the track on the right, that is, the eastern rail, or press far stronger against the rail on this side; and that the inclination for jumping the track increases with the growing velocity of the train, and the less the rail track deviates from the meridional line. It was at first and plainest noticed on the English West line. The same observation was also made on our Hudson line, and when attention was called to this peculiarity, other roads confirmed it. All sorts of explanations were vainly tried, such as the construction of the locomotive, meteorological appearances, magnetism of the earth, etc., until some one finally conceived the idea that the phenomenon might be explained by the revolution of the earth from west to east. Further observations fully confirmed this hypothesis, and this peculiarity may safely be stated as due to the earth's axial revolution. The same thing occurs with rivers. Those of the northern hemisphere,

with a northward course, undermine their eastern banks, and the same also takes place in rivers of the southern hemisphere with southern course.

The watchmakers of Vibog (Denmark) have come out victorious from a singular strike; they agreed not to wind the watches exposed in their show windows, and to have their hands point to noon, whereby they forced the aldermen of the city to erect public clocks. The strike was effective, and although the burgomaster of the burgh declared it to be a bad joke, still, the town assembly voted funds for the purchase and erection of several horological conglomerations.

F. G.

Mr. McFuzee thought there could not be a question but that the revolution of the earth was the cause of the rivers undermining their banks and things as they did, and of the locomotives pressing the rails, and jumping the tracks, and all such. No reasonable man could doubt it. The idea that the construction of locomotives, and meteorological appearances, and magnetism, etc., could have anything to do with it was absurd—it was utterly impossible, and no rational being in his senses could believe such a thing. He pronounced it a discovery of the first water, and said he had often noticed, when he lived out west, that he had a constant hankering to "come east." He supposed then that it was caused by a desire to see the old man. But his feelings had often been hurt by the insinuations of relatives that he was after some of the aforesaid old man's "rocks"—which was a base and unfounded slander. Now it is clear that it was the earth's axial revolution that produced such a powerful tendency to the eastward—so powerful that he was often unable to resist it, and was carried east in spite of all his efforts to the contrary. Nor was he a solitary instance. Everybody there had the same inclination towards the east. The crops came east, so did the stock, the money, and everything else. It *must* be caused by the revolution of the earth. There could be no doubt about it, for no lesser cause could affect everybody and everything at the same time, as this did. He thought this should be followed out in all its ramifications, as it might lead to still greater discoveries. He moved a vote of thanks to Mr. G. for putting us on the right track, and hoped he would keep on in his good and noble work.

ONE OF OUR Canadian exchanges comes to us laden with complaints regarding the smuggling that is going on across the border. A case is cited of a firm that has recently been detected smuggling goods into the Canadian markets, and who are supposed to have avoided the payment of duties that would aggregate \$10,000. Smuggling over the Canadian border is a double-edged sword that cuts both ways, and dealers in this country have equal cause with their Canadian brethren to complain of certain classes of goods that find their way into the market without having paid duty. It is almost impossible to prevent the transportation of goods across an imaginary line some 2,000 miles long, and, so long as unscrupulous men find a profit in doing it, it will be done. We presume both governments exercise all the vigilance possible under the circumstances, but it would require a greater force of officers than either of both governments can afford to guard every possible avenue of entrance and exit. The great incentive to smuggling lies in the apathy of the people. While the law makes it a felony to import goods without the payment of the duty, the people are inclined instead to treat such offence as a good joke on the government, and to take such advantage of it as is offered them in the lower price of the goods. Our importers are being constantly brought face to face with smuggled goods, which are offered at prices so low that they cannot compete with them, yet they are bought and sold by persons of supposed respectability, who must know from the price, if nothing else, that they are smuggled. These persons would be the first to condemn the robbery of an individual, but are not only willing to see the government robbed, but to aid and abet the robbers. Until smuggling is popularly recognized to be a crime, and all accessories thereto as guilty as the principal, smuggling will continue. We understand that our government is endeavoring to enforce stringent regulations on the Canadian borders, and, where there is detection, the penalties enforced against those who buy as well as against those who bring the goods over. If a few of our citizens who are looking for bargains in smuggled goods should find themselves under arrest on a criminal charge and the goods confiscated, they would scarcely chuckle so freely over these jokes on the government as they now do.

Sight.

WHAT THE OPTICIAN SHOULD KNOW ABOUT OPTICS.

Based upon an extensive hospital experience in Austria, Germany, England and New York. By C. A. BUCKLIN, M. D., New York. Author of Detection and Correction of Visual Imperfections, Cause and Cure of Cross Eyes, Effects of Color on Distance, and Monograph on Astigmatism.

Continued from page 90.

OUR READERS will be interested to hear from our experimental attempt to adjust cylindrical lenses to Mr. Dollenmayer's eyes, who resided in Wilson, Kansas. Mr. D. lived so far from any skilled expert that it was thought proper to try and prescribe cylindrical lenses for him without having seen him. It never had been done before. After a long and tedious correspondence through THE JEWELERS' CIRCULAR, we succeeded in adjusting lenses which were perfectly satisfactory. Mr. D. writes the lenses are satisfactory for each eye.

Now I wish to ask you a question. A person who is near-sighted comes into my office for a pair of glasses; fifty feet from my shop is a pole two inches in diameter, and one mile is a post six inches in diameter. When I give her a say No. 24, she can see the pole but not the post; a No. 20 brings the post to view, but a No. 18 makes the post clear. Should I give the No. 18? In other words, should I always require the patient to see the post at the distance of one mile, or is that test too much? You will favor me by answering above.

Yours truly, E. Y. DOLLENMAYER.

Posts accidentally helped me to a conclusion as to what the trouble was with Mr. D.'s eyes—they are not a reliable test for distant vision. For degrees of near-sightedness not greater than $\frac{1}{10}$, the weakest concave glasses may be given, which make the last line of block numbers in the June number, 1882, of CIRCULAR, *perfectly distinct* at twenty feet. These block letters at twenty feet should always be used for testing distant vision. Young persons having weak eyes who are far-sighted, should have the strongest convex lenses through which they can see the last line of block letters at twenty feet.

Elderly persons should have the weakest convex lenses with which they can read the newspaper with *perfect comfort* at fourteen inches.

When the near-sightedness is greater than $\frac{1}{10}$, such glasses must be given as are most comfortable for the patient. The objects must not look too small. If the disturbance of relation between the converging of both eyes at a common object and the focusing of the eyes for this object be too great, objects will begin to sway and the lenses will not feel comfortable.

CASE.

The subject is about 53 years of age. By occupation a watchmaker. Reads well with 40 to 60 inch focus, convex S glasses.

Cannot clearly see distant objects with the naked eye, but with the aid of 60 inch focus *concave* S glasses, can see distinctly at long distances.

With my limited means of testing, (cve. and cx. *spherical* lenses, the articles in your journal, Dr. Bucklin's book, and such tests as are contained in Jas. W. Queen & Co.'s catalogue), I find the following characteristics present.

The subject can see with but the left eye, the right eye being entirely blind from childhood, through an accident.

First—With the radiating lines in the book, and in the June number, 1882, of your journal.

With the *naked eye* the lines appear all alike at three to four feet distance.

At 10 feet distance, the vertical line, with the lines 10° and 20° right and left, are distinct, the other lines becoming more confused as you approach the horizontal lines, which are very much blurred.

With a 60 inch focus, concave S lens, the lines maintain an equally black appearance within a range of from 4 feet to 10 feet; on receding to a greater distance, *all* the lines gradually fade away and become indistinct.

Sharply defined white lines crossing each other at right angles presented to the eye at a distance of 18 inches, and using a 34 inch lens, convex S., the lines all appear to be equally well defined.

Approaching from 18 to 12 inches, the *horizontal* lines remain distinct, while the *vertical* lines gradually disappear, becoming entirely blurred at the distance of 12 inches.

Receding from 18 to 26 inches the condition is reversed, that is,

the *vertical* lines remain distinct, and the *horizontal* lines fade and become blurred at 26 inches distance.

With 60 inch cx. S. lens the same conditions prevail except as to range and distance.

From the observations made, it appears that the astigmatic condition is exactly reversed by the use of spherical lenses.

Now, the question is, can you from the data here furnished, tell the focus and combination of S. and C. lenses needed to correct the vision of the subject?

The writer of the above is a very careful and close observer. He has made many observations that are unnecessary, however, and has omitted some quite necessary to a conclusion.

His age shows me at once that he is probably slightly presbyopic, although he has a slight degree of myopia, which prevents him from seeing distinctly at long distances. He also plainly shows a mild degree of myopic astigmatism. I can easily guess the combination of lens through which he would see best, but the necessary facts to arrive at a positive conclusion are wanting. Simple radiating or crossing lines seen at the greatest distance at which they can be plainly seen are the only special tests for astigmatism of any value. The figures in Queen's catalogue will show an astigmatism which is too slight to require correction. It is a fact that nearly every person has a moderate degree of astigmatism, and the figures bring out degrees of astigmatism that are physiological (not abnormal).

The fact that one eye has been injured arouses in my mind at once a suspicion that the other eye has suffered from sympathetic irritation. I must know the greatest number of feet at which he can read the block letters xx, June number, 1882, without any lens and with the best concave lens. How the radiating lines appear at this distance with this lens. They should always be observed at a distance, as the accommodation is then at rest. When observed from near by, it is impossible to estimate the part the accommodation plays. He should also state at length what the individual complains of, and if he desire a lens for distant vision or for reading. Probably at his age the combination best adapted for distance will not answer for reading. If he can read distinctly the last line of block letters, June number, 1882, at 20 feet with concave 60, he probably will not require any cylindrical lenses; his astigmatism is too slight to require correction. If he require an astigmatic correction, the lens for distant objects would probably be $-60\text{ S} = -60\text{ C.}$, axis horizontal. For near vision it is more than probable that $+40\text{ S} = +60\text{ C.}$, axis vertical, would be the combination through which he can read best. If he finds that his eyes tire with reading through convex 40 S., he probably will require a cylindrical correction for reading only.

If the above inquirer lives so remote from an expert that it is impossible for him to consult one, I will make the experiment of adjusting the lenses by mail, provided the 40 convex S. lens tires him. I would always like to know the number and kind of a spherical lens which reverses the blacker lines from a vertical to a horizontal position or from a horizontal to a vertical position, when they are viewed at a distance of ten or more feet.

I have had so many other inquiries about astigmatism which have not a single point in them from which I can draw any legitimate conclusion as to what the trouble is, that I will give an exact list of the questions necessary to answer:

I. Age; occupation; have glasses been used; if so, what number and kind?

II. Give at length everything the person complains of, particularly how he sees distant objects and near objects.

III. What is the greatest number of feet at which each eye can see last line of block letters in June number, 1882, with naked eye? How strong a convex glass can each eye see them through, or do convex lenses make the vision worse? If the last line of block letters in June number 1882, cannot be seen by either eye at twenty feet, do concave lenses make the distant vision any better? If so, what is the number of the weakest concave lens which makes these letters look the clearest?

IV. What are the weakest *convex* lenses with which the person reads with comfort? If concave lenses are required for reading, state the number. In each case state in inches the distance the person habitually holds his paper from his eyes.

V. If no spherical lenses are found which are perfectly clear and satisfactory, try the astigmatic disk at ten to fifteen feet. State which lines are the darkest with both eyes and with each eye separately. If the lines are not alike, please state the number and kind of the weakest spherical lens which reverses the darkest line to a position at right angles to its former position.

Persons inquiring about astigmatism should answer these questions in full. The complaint of the patient frequently gives very valuable information.

If a person comes to you complaining of weak vision, and is under forty, you will not expect presbyopia. If he can read the last line of block letters in the June number, 1882, distinctly at twenty feet, he is not myopic or astigmatic. He probably will require convex lenses to relieve his weak vision; he may have some abnormal condition of accommodation, or of the muscles which direct or fix the eyes. In most cases properly selected convex lenses will remedy the difficulty.

If the individual cannot read the distant block letters, you at once suspect myopia, astigmatism or disease. If he reads perfectly at short distances without tiring, he is probably myopic, even though he should find it necessary to close one eye to read with comfort. If he sees badly at a distance and convex lenses do not improve it, and he still has trouble with reading, the astigmatic disk will usually show that he is astigmatic. The rules given above will show you how to describe the case when the person has this defect.

The trade is continually asking me if I can prescribe and send lenses which will fit their patient and what it will cost. If the person resides so far away from an expert that he can afford to spend ten dollars in experimenting, providing cylindrical and spherical lenses are to be combined, or five dollars if simple cylindrical lenses are required, I will try and do the best that can be done. To send you spherical and cylindrical lenses in round frames, and then have them put in required frames, costs me five dollars. If I have to resort to a second experiment with these combined lenses, it will cost me nine or ten dollars. I am always liable to have the lenses returned to me as being unsatisfactory. If the first experiment proves satisfactory the bill to the patient should be fifteen dollars at least. The trade will be allowed one-third off the entire amount in this case. If I have to resort to two experiments and the fee is the same, there will only be five dollars left for risk and services; the trade will be allowed one-third of this amount.

The difficulties are so great in fitting cylindrical combinations that I would always urge on the patient the necessity of his consulting an expert oculist to preserve his sight. If I am the one selected, my price for services will be five dollars to men who do not own property or do not conduct a business of their own, one-third off is allowed to the optician. Parties who own property or have their own business, my price is ten dollars for my services in making a careful examination, one-third off is allowed to the optician. Where operations are to be performed to straighten cross eyes, remove tumors from the lids, or for the cure of complete blindness, the fees are much higher, and one-third is allowed to the optician. I make this statement to the trade only, and in answer to a great many direct questions involving the above facts, and not from any wish to have you direct any of your customers to me. I am rejoiced to see the general interest taken by opticians in general in the correction of visual defects. Several wholesale houses tell me that they have noticed a great improvement in the positive manner in which their customers order what they want. It formerly frequently happened that they would receive orders for a large number of concave lenses; when the goods were delivered, they would find convex periscope lenses were desired.

DR. BUCKLIN:

Dear Sir—I wrote you that I had a difficult case, a lady who

thought she could not see near as well as she wanted, or as she thought she ought to. Uses quite a strong concave glass; vertical lines at a distance of 10 to 16 inches are the blackest. At four or five inches that astigmatism disappears. Nothing in front of the sight and not much variation, *i. e.*, she can see about as well one time as another with naked eye. Greatest distance at which test type on page 73 (Bucklin, by Spencer Optical Mfg. Co.) can be read is five inches, test $D=0.5=19.68$ inches. Can you tell by this what glasses she ought to have and what you will charge?

I sincerely regret that I am not able to give my friend the required information from the facts stated in his letter. The person is evidently near-sighted, the amount of which can only be determined accurately by testing distant vision with concave lenses, as already described in Question III., this number. Also after the myopia has been corrected with concave lenses as perfectly as possible, I should like to know the number of the concave or convex lens necessary to change the black line from a vertical to a horizontal position, and necessary to cause the horizontal line to appear exactly as black as the vertical line appeared without this spherical lens. The age of the patient would give me some idea about the amount of presbyopia. Would like to know whether patient desires to have a glass for distant vision or for reading. Also what patient complains of when reading, what lenses she uses to read with now if, any. I think if the questions were carefully answered, I could give a fairly correct idea of the nature and degree of the trouble. I, however, must insist that it is a mistake to try and fit an astigmatic person in this way if they can possibly get to a careful expert. Mr. Dollenmayer lived so far from an expert that there was reason in his attempt to obtain cylindrical lenses by this method.

Lyre Clock.

DECORATED BY COTTEAU.

In the Jones Collection at the South Kensington Museum.

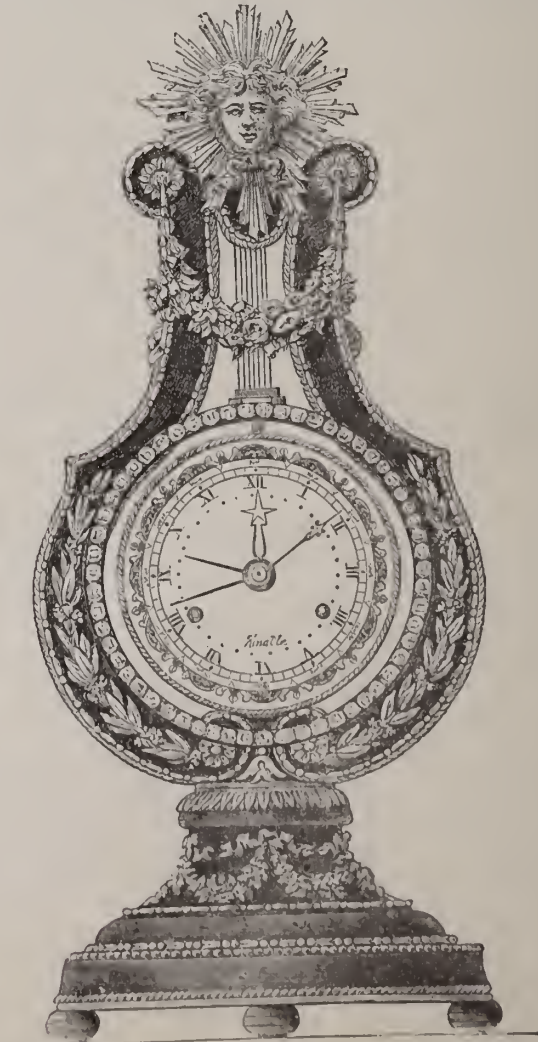

(From *Art Amateur*).

AMONG the many beautiful works of art in the Jones bequest, recently opened to the public in South Kensington, England,

are a number of elegant, unique and costly clocks. We present here with an illustration of one of these, lyre-shaped, which is mounted with chased ormolu. The dial is painted with signs of the zodiac by Cotteau. The pendulum is a ring of paste diamonds, and hangs in front of the dial. While the clock is undoubtedly a very beautiful one, and deserves the marked attention it receives, it is still open to criticism from an artistic standpoint. Especially is the base upon which it rests clumsy in construction, which can only be relieved by the highest ornamentation. The Jones bequest is, according to the *Art Amateur*, one of the most munificent gifts ever presented to the English people. Aside from its purely monetary value, which is thought to exceed £300,000, its artistic worth is almost incalculable, as it contains very many specimens of furniture, china, miniatures and enamels, which are absolutely unique, and therefore almost priceless. The collection exists intact, as it was removed from the residence of the giver, a wealthy tailor who retired many years ago and whose leisure and fortune were devoted to gathering the objects of art which now occupy a series of galleries in the museum.

Confession of a Bric-a-Brac Dealer.

“A WORD as to buying cheap imitations of articles which are not susceptible of being fairly reproduced,” said the old dealer in bric-à-brac. To purchase an imitation of *cloisonné* ware, for example, is to make a bad error in taste, for its beauty depends, not upon its form or color, but on its exquisite handiwork, a quality of which no imitation can give the least idea. Here is a piece of imitation Japanese *cloisonné*. It is of copper, like the genuine, and, for cheap enamel, has a rich appearance. Now examine it beside an original piece. The imitation, you observe, becomes dull and tawdry looking, and the colors do not appear fresh or distinct. It is, however, in its base imitation of tracery that the thing shows out really false and abominable; the lines of gold or brass are daubed on with a brush. In the genuine article the markings between the colors and all of the tracers are firm and clear, for the point in *cloisonné* is to tool little gutters of metal in the copper, and press in the fine wires, golden or brazen. No imitation can give any idea of the effects to be gained in this way.

“The bit of imitation *cloisonné* I have shown you is of home manufacture, and is bad enough to protect the buyer; the really dangerous imitations are made by the Japanese themselves, for it is a sad fact that the American demand for cheap art goods has demoralized the best artists in the world in this kind of work. Beware of *cloisonné*. The most deceptive thing in bric-à-brac I ever saw was a so-called *cloisonné* vase sold as damaged. The injury consisted of a break in the metal only half an inch long, but sufficient to disclose the fine threads of the tracery, which had in fact been torn from their beds. As the break was susceptible of perfect repair, the object brought a high price. On examination it was found that apart from the threads laid bare there was not a single *cloisonné* wire in the vase; all the rest of the tracery had been painted on, the break having been especially made to show a construction which did not exist in fact. The article was worthless.

“There is one point in the purchase of bric-à-brac in which we Americans are egregiously deceived. We import large quantities of several kinds of Japanese and Chinese art goods which had previously been imported into those countries from the manufactories of Birmingham, England. The fact does not speak well for our vaunted acuteness. Even the hammered bronzes of China and Japan are often but clumsy specimens of English stamped work. Birmingham manufacturers do not object to helping one-half the world to deceive the other half, provided the material part of the work is done in their shops.

“As for Sheffield manufacturers, they show a boldness in the manufacturing of sham art work which exceeds all their proverbial impudence in turning out sheet-iron razors. Some of our young ‘bloods’ acquire in Paris a taste for old arms. A few years ago

they ransacked New York for them, and many an old Dutch carving knife under a fancy name found its way to the glittering circles of cutlery over their mantlepieces. The Sheffield manufacturers noted the demand, and we were soon flooded with an unseemly lot of polished iron. I was obliged to keep some of it. We had terrible looking corkscrew swords, Turkish scimitars weighing twelve pounds, flashing cutlasses, Spanish daggers, Italian stiletos, French foils and Damascus and Toledo blades in abundance. They were mere toys, harmless things that would hardly penetrate cloth, but they sold at high prices. Let me show you a true blade. Here is a fine Toledo dagger, exquisitely engraved and Damascened. It is small and light, running down to a long, fine point; yet when I place this English penny piece on the table—so—I can drive that point down through it, and—see—the point remains uninjured. A blow like that would bend up those Damascus daggers from Sheffield like so many fish hooks. This fashion has now given place to a passion for collecting bad firearms—guns which never seem to hit anyone except when they go off by accident. Some of the old Sheffield ‘arms’ may still be seen in the Bowery accumulations of pawn shop bric-à-brac.

“Ivory goods?” The old dealer’s eyes twinkled. “I just happened to think,” said he, “of an order I had three years ago for half a dozen ivory diptychs and an assortment of Etruscan carvings. That was about the most preposterous order I ever received. I was irritated at first, but grew amazingly cheerful as I thought of my customer’s greenness. Some men imagine that money will buy anything, old or new, in existence or out of it. It is true that some fine specimens of ivory taken from Etruscan tombs are still preserved. The British Museum has a dozen of them, and some are extant which were known to be in existence at the time of Moses. But as to buying them as you would a bootjack—

“A diptych, you know, consists of two carved ivory covers, each from 8 to 14 inches long and proportionally wide. The Greeks used them for writing tablets, and the Romans gave them to Consuls for presents; that is how the fashion arose of giving portfolios to Cabinet Ministers. They were rare even in their day, and as the iconoclasts destroyed all the ivory carvings they could lay their hands on, you may imagine how scarce they are at the present time. Even European Museums count themselves fortunate when they possess half a one; so the six diptychs ordered by my customer would have made a bad hole in his fortune.

“I think it was in the spring of ’76 that a greatly dilapidated fellow called on me and pointed to my private office. He locked the door and took from under his coat a 14-inch diptych which he offered to sell for \$1,500. Had he offered me the Vatican or St. Peter’s for a like sum I shouldn’t have been more surprised. I knew there was something wrong, but could not say where. The marks of age, etc., were perfect, and the work stood the magnifying glass wonderfully well. When at last I determined to take off the frame and backing, the man went down on his knees and begged me not to expose him; he had stolen it from a Pavian monastery, he said. It proved to be carved on new ivory, ingeniously pieced out and fairly well cut; it had been manufactured in a garret in Pisa by a man who makes a business of it. I let the fellow go; he did not lie any worse than dealers are often obliged to do, and was only like us, selling goods for something else than what they are. The rascal also had two replicas in his pocket; the three articles worth only about \$50. Five years afterward I saw one of them in a well-known private library in Thirty-fourth street, but made no sign.

“There are many methods of making imitation ivory carvings. Sometimes the material is sawed into thin sheets, steamed in softening vapors, and pressed into moulds. It is then stained for age, cut, filed or otherwise tortured into shape, and, after being filled with cement, is backed with an ivory veneer and offered for sale. Relief figures are made from a composition of ground bone and gum, and then cast and polished. But lack of luster and grain betrays them to careful observers. If you buy ‘Japanese’ cabinet work, ornamented with raised ivory carvings, handle it carefully, for a sharp rap will often powder the bogus ivory. Look out, too, for imitation mother-of-pearl. It is a comparatively new sham in ornamental art, and liable to damaging accidents upon very small provocation.”



THE SCHOONER PRIZE PRESENTED BY OGDEN GOELET TO THE NEW YORK YACHT CLUB.
(From *Art Amateur*).

THE ABOVE cut illustrates the Schooner Prize presented by Ogden Goelet to the New York Yacht Club. The Cup and Tray are beautiful specimens of artistic work, and have been very greatly admired by lovers of such work. The Cup is twelve inches high, and the Tray is eighteen inches long, both being made of solid oxidized silver, studded with enamel work. The design is by Mr. Charles Osborne, of the Whiting Manufacturing Company, and the work was done at the factory of that company. The inscription on the Tray is as follows: "Schooner Prize, presented by Mr. Ogden Goelet to the New York Yacht Club. Won by the Schooner yacht 'Montauk,' Samuel R. Platt, owner, Newport, R. I., Aug. 8th, 1882." The charmingly decorative treatment of the inscription is indicated in the illustration.

BABYLONIAN SILVER.—The British Museum has just acquired an interesting collection of 39 silver objects which give an insight into the daily life of the Babylonians, and remind us of the find of the bird dealer's shop at Pompeii. These objects, which were all found together on the site of Babylon, consist of fragments of silver dishes, the broken handle of a vase, and coins, most of the latter being defaced and clipped. It is easy to see that all have been broken purposely by a practiced hand, with the view of using the metal again, and we may fairly conclude that the collection is the remains of a silversmith's or coiner's shop. Among the coins is a Lycian one in good preservation. So far as can be judged from the vase handle and dishes, the art is distinctly Babylonian under Persian influence, and the workshop may date from the conquest of Alexander.—*The Academy*.

Gold and Silver—their Elaboration.

(Continued from Page 75.)

ARTICLES of nickel alloy, copper, bronze or brass are easily silver plated by the galvano-electric method, while those of cast or wrought iron, or steel, must previously be coated with copper before being silver plated, which is also to be done by galvanism. Since this coating is simply for the purpose of forming a suitable surface, it need only be sufficiently thick to cover the metal underneath, after which the article is silver plated.

XXI.

GALVANIC GILDING.

The process of galvanic gilding very much resembles that of galvanic silver plating, since the main features are common to both. There are certain differences, however, which must be observed, without which it would be impossible to obtain a handsome gold plating.

It was found that cyanide of silver was the most appropriate preparation for silver plating, and experiments soon proved that cyanide of gold, in form of a cyanuret of gold and potassium, was also the most suitable for gold plating. The solution of this salt can either be prepared in the manner heretofore specified, or else it may be produced by the aid of the electric current from gold and cyanide of potassium.

The latter method is entirely similar to that described for preparing the silver solution; a sheet of chemically pure gold is placed into a vessel of dimensions adapted to the quantity of fluid to be produced, and in the center of the vessel a clay cell with a piece of iron; both vessels are filled with cyanide of potassium solution, the whole arrangement is placed into a tin vessel filled with water, the gold sheet and the iron are connected with the galvanic battery, and the water in the tin vessel is heated to about 70° or 80° C.

It must be remembered that the solution, as well as the separation of the gold by the galvano-electric process, takes place only at such a time with sufficient speed when the fluids are raised to a higher temperature; the higher this is the weaker need the battery be, and the shorter the time for obtaining a gold deposit of sufficient thickness; the color, also, of the deposit can be regulated by the temperature of the bath.

The concentration of the gold-plating bath varies with its purposes; baths to be used for small trinkets, silver watch cases, etc., are generally of a low grade of concentration—20 to 25 grams gold to 10 liters fluid; those to serve for large work, such as clock cases, bronze vases, statuettes, etc., are made stronger, and from 30 to 50 grams gold are added to 10 liters fluid.

Gold plating itself is done by placing a sheet of gold in the vessel intended for the reception of the bath; the fluid is then poured in, and its height carefully marked inside. This is of importance, since a certain quantity of water always evaporates during gold plating, whereby the concentration of the bath would become too great. When the work is interrupted, sufficient water is added until the level of the fluid reaches again to the mark, when the gold bath is carefully covered to prevent the falling in of dust.

As far as the cleansing of the articles to be plated is concerned, the rules laid down for silver plating also apply to gold plating; it is indispensably necessary that their surface be a pure metallic one. Silver articles, after being treated in the soda lye, must always be cleansed in a sulphuric acid bath; copper, bronze or brass ones may also be treated in this bath, but one of nitric acid is preferable for the reason because it cleanses in a shorter time.

The separation of the gold is always accompanied by the development of hydrogen, which must take place only in a small quantity. Too strong a development is always a certain proof that the current is far too powerful, and the gold is separated so quickly that it does not precipitate upon the article, but falls to the bottom in the form of the well-known brown powder.

With a little practice, this evolving of hydrogen offers a very good

sign by which the course of the process may be judged. As above said, too powerful a current occasions a strong development, while a moderate one is a proof of the correct course of the process, and in this case a gold plating of a dark gold color and handsome luster is obtained; should the course of the process be so slow, however, that no evolving of gas can be noticed, the gold deposit will be of a pale gold-yellow color.

If it is found that the process takes place in an imperfect manner, so that the current passes too quickly, the article must be stripped again of gilding, to be done by changing the conduits of the battery, so that the one formerly connected with the sheet of gold is now connected with the object, and *vice versa*. After the gold has separated from the object and deposited on the gold sheet, the conduits are set right again, and the current is regulated so that the separation of the gold takes place in a correct manner.

If the gold plating proceeds too slowly, the cause may be due either to the weakness of the electric current or the temperature of the bath; if the latter is the case, its degree of heat is to be raised to about 90° C. With the temperature of the bath at 60° C., from three to four elements are necessary, while a single one suffices at 90° C.

The time during which the article has to remain in the gold-plating fluid, apart from the quickness of the depositing of the gold, also depends upon the thickness of the gold coating to be produced; articles of a smaller kind, for instance, silver trinkets, watch cases, etc., are generally sufficiently gold plated in from three to four minutes.

Gold plating effected, the articles are removed from the bath, repeatedly dipped into water, finally heated in boiling water and dried; a slight rubbing of the articles with soft woollen cloth generally suffices to cause the gold luster to appear, at other times it is produced by the customary burnishing. The wash waters, which always contain a certain quantity of gold, are collected and the latter retained.

Larger vessels, such as tea pots, drinking cups, and others, if to be gold plated within, are wrapped around with a wire; this is then connected with the negative pole of the battery, and the inner space filled with the gold-plating fluid as high as the gold plating is intended to reach. The gold sheet standing in connection with the positive pole of the battery is then dipped in, and the gold precipitates on the sides of the vessel as long as the sheet is in connection with the fluid.

GOLD PLATING WITH COLORED GOLD.

All the desirable shades of the green and red gold can be obtained by the electro-chemical method, and they are excellent for producing beautiful effects. In order to produce red gold in the different gradations of the color, a sheet of pure copper is suspended in a rather concentrated gold bath (five or six grams per liter fluid), connecting the battery with the copper in such a manner that gold precipitates upon the article immersed in the bath.

But copper also dissolves, due to the influence of the electric current, and is precipitated at the same time with the gold, so that after a certain time a deposit is obtained consisting of a gold-copper alloy, the color of which corresponds to the quantities of these metals contained in it.

When the desired tone of color is produced in the precipitate, the copper sheet is lifted out and replaced by another one, consisting of the copper gold alloy, and which now gold plates the articles in the fluid, or rather colors them.

To produce green gold or gold-silver alloy, a silver sheet is first dipped into the gold bath, and from which sufficient silver is reduced into solution, until the precipitate shows the desired color; this silver sheet is next exchanged for a gold-silver sheet of the corresponding color, when the articles are gold plated with green gold.

ELECTRO-CHEMICAL GOLD INCRUSTATIONS.

We have previously spoken of the production of gold incrustation, and next mention the most necessary points concerning this branch.

The principle of incrusting is based upon the fact that certain portions of a metallic object may, by an appropriate covering of some isolating layer, be protected against the coating of metal by the electric current, in consequence of which the operator has it in his power to produce sketches, composed of different colored metals, upon a metallic ground.

The ornamenting of gold and silver articles, as well as those consisting of other metals, with gold or silver, which is deposited in well-defined shapes, is done in a rather simple manner, and at the places where no deposit is desired, it is provided with a coating of varnish, to be applied with the brush or plume.

We have already specified that a varnish consisting of asphalt and benzole is very suitable for this purpose, it is liable to the only objection of being rather volatile, which is checked by the addition of a corresponding quantity of oil of turpentine. A ground very appropriate for finer work is also obtained by melting two parts asphaltum and one part mastic, and stirring in sufficient oil of turpentine so that it is liquid enough, when heated, to be applied with the brush, but hardening upon cooling.

The manner of working with this ground is similar to that employed with the ink in lithography; parts to remain free from the metal coating are covered with the varnish, faulty places are corrected with the graver. The depositing of the metal having been finished, the ground is softened by laying the object in benzole, and removed by brushing. By repeating this several times, and applying the covering varnish in appropriate places, articles of a highly artistic finish can thus be produced.

Articles manufactured of thin sheet metal, and upon which scenes or figures have been worked either by chasing or pressing, may be embellished in a very artistic manner by precipitating suitably-colored gold alloys upon the different parts, and after completing the article will appear as if inlaid with different colored gold.

If certain places of metallic plates are covered with such varnish, then laid into very dilute nitric acid, and connected with a galvanic battery, the bare places are very quickly eaten out. When sufficiently deep, the plate is rinsed off well, and at once laid into the silver or gold plating bath, in which it is left until enough of metal is precipitated into the hollows to fill them level. Such articles, after having been ground and polished, are very similar to niello work.

PLATINUM PLATING.

On account of its insignificant gray color and difficult working, platinum has found but little employment in industry, and is sometimes precipitated galvanically upon other metals. Platinum belongs to the nobler metals, since it also possesses the property of being easily separated from its combinations.

Nevertheless, the production of handsome platinum precipitations in the electro-chemical way offers many difficulties, only to be overcome by suitably preparing the platinum bath.

Chloride of platinum is to be used for the baths, produced in such a manner that platinum is dissolved in nitro-muriatic acid, and evaporating the solution to dryness in the water bath. The remaining brown substance is redissolved in water, and again dried, whereby a brown crystalline mass of chloride of platinum remains.

An excellent platinum-plating bath is composed as follows: One part of platinum is changed into platinum chloride, which is dissolved in water and one part dissolved caustic potash is added. A precipitate ensues, to be dissolved with a solution of two parts oxalic acid in water, and another three parts of caustic potash are still added, after the precipitate has been dissolved.

It is said that a fluid specially suited for the production of a well-adhering coating, is obtained by adding a soda solution in drops to one of platinum chloride, as long as carbonic acid escapes from the fluid. This fluid, mixed with a solution of starch sugar and culinary salt, is used as the platinum bath. It appears that the beauty of the platinum precipitate depends chiefly upon the proportion in which starch sugar and culinary salt are present, and only actual tests will determine the quantity proportions, by which the precipitations are handsomest.

XXII.

FIRE GOLD AND SILVER PLATING.

Before it was known how to produce deposits of the noble metals in a handsome and simple manner, by the use of the galvanic current, the only process by which this could be effected was the fire gold or silver plating. This process is frequently employed even at the present day, when metallic articles are to be coated with gold in a durable manner, for instance, the points of the new flags the French army received in 1880.

The objections to be urged against this method are that it is dangerous and detrimental to health, since by the use of every precaution it is almost impossible that the workman can protect himself thoroughly against breathing the very noxious vapors of the mercury, which circumstance has contributed not a little to its being supplanted by the chemico-electric process. This, also, has its drawbacks, as we have shown, since the minute quantities of the cyanide evolutions escaping into air during galvanic gilding are certainly of a not less injurious effect than a larger quantity of mercury.

There are many means of protecting one's self against these exhalations during gold plating, and the first preventive should be to have this work performed in a bell furnace, with a very strong draught, and to compel the workmen, during the time that they are occupied with this labor, to wear a small mask by which mouth and nose are sheltered, and consisting of damp sponges. The mercury vapors are thus retained in the sponges, and the workman only breathes pure air.

The work of fire gilding is at present but seldom used for silver; the gold coating upon this metal assumes a peculiarly pale yellow. Bronze articles are mostly gilt in this manner; other metals, except copper, cannot be gilt directly, but must previously be coppered. Fire gilding is peculiarly suited for bronze, because the workman has it in his power, by a skilful treatment of the article during gold plating, to cause the gold to appear of any desired shade of color.

The method of fire gilding consists in applying mercury gold amalgam to the article to be gold plated, and heating it until the mercury is evaporated; several other manipulations are to be observed, however, and the entire work can be classified as follows:

1. In the pickling: The production of a perfect metallic surface upon the article to be gold plated.
2. The quickening: Coating the articles with a layer of mercury.
3. The amalgamating: Applying the amalgam in a layer as uniform as possible.
4. The driving off: Evaporating the mercury contained in the amalgam by heating above charcoal.
5. The so-called retouching: Repeating the quickening and also the subsequent operations for the purpose of producing a heavier gold layer.
6. The treatment with coloring substances: That is, heating the gold plated article with certain chemicals for the purpose of producing different colors.
7. The matting, or removing the luster from such places of the gold plated articles that are intended to be mat.

Except the retouching and matting, all the preceding operations must be executed, when an article is to be gilt in fire, and we shall describe the different operations in their order.

THE PICKLING.

All the metals intended to be fire-gilt are those that dissolve with facility in nitric acid; for producing a thorough metallic surface a bath of nitric acid is used. This removes at first the film of oxide upon the article, and attacks the metal itself afterward, whereby it is thoroughly brightened.

In order to still increase the effectiveness of the nitric acid, one-third part sulphuric acid is added; this withdraws water from the nitric acid, and reduces it to the highest degree of concentration, so that the article need only be immersed for one second to have it perfectly bright.

Another object is attained by the use of the highly concentrated acid, since the article is matted thereby. If the article is left for a few seconds in the nitric acid pickle, rinsed and examined with a magnifier, it will be found to have become punctured, the nitric acid having unequally attacked the unequally dense metal. The longer it is left in the nitric acid, the rougher the article becomes, and the more gold amalgam is required to coat it, but the handsomer and better the gold plating will also result. The workman, consequently, must consider well whether the article is to receive a heavier or thinner coating of gold; the duration of the pickling depends upon it. The experienced workman can decide at a glance whether the article is sufficiently pickled or not; he next rinses it quickly in water, to annul the operation of the nitric acid, and then keeps it in water until he arrives at the work of

QUICKENING.

Silver articles are not quickened, since the gold amalgam adheres with ease to them, as long as they are perfectly cleansed; it must be done with copper or bronze objects, upon which a layer of metallic mercury is to be divided first, so as to prepare the surface for the reception of the amalgam.

(To be continued.)

Watches and Personal Magnetism.

"Sir, you should wear an open-faced watch if you desire to be accurate in your time," said a watchmaker on Chestnut street, Philadelphia, to the stout man; "you are too magnetic."

"Why, what the deuce has the case got to do with it?" was the interrogative reply.

"Everything. Your watch has a hunting case, necessitating steel springs for opening and shutting. By constant association with your body those springs become magnetized, and they generate their condition to other necessarily steel portions of the watch works, and thus render their movements imperfect."

"Then, if I were not fat, my watch would not lose two minutes, more or less, a day," said the puzzled stout man.

"Exactly," returned the watchmaker. "I have worn your watch for over a week and it has neither gained nor lost a dozen seconds; but then I am, from a corporal point of view, your antithesis. I am exceptionally thin and slender."

The stout man mused. "Accordingly," said he, "open-faced watches for fat men, closed cases for thin, eh?"

"Not at all," replied the other. "Thin men have at times more magnetism in their systems than fat men. Everybody is more or less magnetic; you happen to be particularly so; I happen to be quite the reverse; hence my remarks and advice. For the rest, open-faced watches are always more accurate than hunters. They are more air-tight for one thing. As for the steel springs in hunting cases, mechanical science has not yet discovered anything else to replace them; the public like double cases, and there the matter remains for the present. There are, however, many ill-contrived portions in watches, and while the demand continues for watches of a certain price it is impossible, from a commercial point of view, to think of improvements. Long-used methods and ingenious engines have been specially provided to fashion and cut out every one of the minute parts which go to compose the existing instrument. Every watch consists of over 200 pieces employing over 200 persons, distributed among forty trades, to say nothing of the tool makers for the artisans. If the construction of the watch was materially altered, all the trades would have to be re-learned, new tools and wheel cutting engines would have to be devised, and the majority of working watchmakers become useless. The consequence would be that the watch would become enormously enhanced in value, and its possession a token of wealth. You see, in your complicated state of society, even machines, in the process of time, come to surround themselves with a circle of 'vested interests' which embarrass attempts at improvement."

"You are interesting me," remarked the stout customer, as he placed his watch in his pocket. "You have been many years, I suppose, in the business. Of course, there must have been some improvements in your time?"

"Of course. Watches during the past ten years have grown much in thickness. Old-fashioned watches are thin and flat. I have had a watch in my charge as flat as a trade dollar. It is impossible to properly adjust such a movement to heat, cold and position under such circumstances. I should have to give you a long explanation to tell you why."

"Well, has the increased thickness raised the value?"

"No. On the contrary, watches are now worth 25 per cent. less than they were twelve years ago. That fact, you will say, bears against my previous remarks. I am referring to the cheaper grade of watches worn by the majority of people. There are watches which bring \$1,500, and watches which can be purchased for \$18 a dozen. If you are willing to pay for costly work almost anything can be accomplished.

"I made a watch for a physician which fitted into a signet ring not much larger than a pea. It had only second hands. It was perfectly accurate, and was used by the doctor to time the pulse of his patients. That cost \$400. Watches are made from the size of a ten-cent piece to half a dollar, and worn as trinkets by ladies. They are also fixed in bracelets, brooches, tops and pencils, eye-glasses, and even umbrella handles; but they are very luxurious toys."

The stout man paid his bill and went home, wondering what the watchmaker had been giving him.

Solubility of Glass.

WE HAVE frequently pointed out how far from correct it is to consider glass an insoluble body; and though, as regards the contamination of solutions by the material dissolved, photography is, fortunately, apparently little troubled, the slightly soluble character of glass concerns photographers in other respects very deeply. Not to speak of the action of moisture in destroying the surfaces of lenses, the manner in which the surface of the glass plates is acted upon is a matter of great importance, so many are the cases where stains in negatives are due to what might be termed "corroded" glass. Before the Chemical Society a paper has recently been read giving an account of the behavior of glass to certain reagents. The hardest Bohemian glass tubes were selected, and the substances were sealed up and then exposed to heat for some days. The contents were now taken out and analyzed. Passing over the accounts of sulphide of ammonium—which is not likely to be employed to any great extent in the photographer's dark room—we find that one hundred grammes of simple water dissolved ten milligrammes of the glass, the same amount of strong ammonia from seven to eight milligrammes, and *weak* ammonia forty-two milligrammes. These are most remarkable results, and by many would be considered as unexpected as remarkable.—*Brit. Jour. of Phot.*

Vaucanson, a mechanical genius, made an automaton flute player and piper in 1738, which were the wonders of their time. The flutist was a figure five feet high, standing on a pedestal, within which were nine pairs of bellows, worked by clock work. The motion of the fingers, lips and tongue were all imitated by this figure, which, by various arrangements of valves, tubes, levers and wheels, is said to have produced music little inferior to the performance of a skilled flute player. The piper was constructed much on the same principle. The bellows of his instrument required a 56 pound weight to produce the highest note. As the fatigue of playing the pipes usually causes the performer, when playing rapidly, to slur over some of the notes, the mimic piper, impervious alike to weariness and shortness of breath, is accredited with having excelled a living one in the clearness of the notes.

Workshop Notes.

DESTROYING THE EFFECTS OF ACID ON CLOTHING.—Dampen as soon as possible after exposure to the acid with spirits of ammonia. It will destroy the effects immediately.

CLEANSING BRUSHES.—The best method of cleansing watchmakers' and jewelers' brushes, is to wash them out in a strong soda water. When the backs are wood, you must favor that part as much as possible, for being glued the water may injure them.

PROTECTION OF IRON AGAINST RUST.—A varnish composed of 120 parts mercury, 10 parts tin, 20 parts green vitriol, 120 parts water, and 15 parts hydrochloric acid of 1.2 specific gravity, furnishes a good coating for iron that is exposed to the weather.

CLEANSING SILVER TARNISHED IN SOLDERING.—Some expose to a uniform heat, allow it to cool, and then boil in strong alum water. Others immerse for a considerable length of time in a liquid made of one-half ounce of cyanuret of potassa to one pint of rain water, and then brush off with prepared chalk.

PENDULUM JARS.—It is well known that all glass jars are not true, and, I have no doubt, often cause errors in the rates of regulators. The advantage of the iron jar is that it can, and should, be bored out perfectly smooth and true, thus getting rid of all inequalities, and, of course, no errors can thus arise from that cause.

CLEANSING GOLD TARNISHED IN SOLDERING.—The old English mode was to expose all parts of the article to a uniform heat, allow it to cool, and boil until bright in urine and sal ammoniac. It is now usually cleaned in dilute sulphuric acid. The pickle is made in about the proportion of one-eighth of an ounce of acid to one ounce of rain water.

WASHING SILVERWARE.—Never use a particle of soap on your silverware, as it dulls the luster, giving the article more the appearance of pewter than of silver. When it wants cleaning, rub it with a piece of soft leather and prepared chalk, the latter made into a kind of paste with pure water, for the reason that water not pure might contain gritty particles.

CUTTING GLASS WITHOUT A DIAMOND.—Scratch the glass around the shape you desire with the corner of a file or graver; then, having bent a piece of wire in the same shape, heat it red hot, and lay it upon the scratch, sink the glass into cold water just deep enough for the water to come almost on a level with its upper surface. It will rarely ever fail to break perfectly true.

FLAT POLISH OF STEEL WORK.—To polish such parts as rollers and collets, first get a flat surface, by rubbing with fine emery on a glass plate or a bell-metal block, and afterward finish off on a zinc block with diamantine; but for levers, you must use a long, flat bell-metal or zinc polisher, and press the lever into a piece of soft wood (willow is the best) in the vise, moving the polisher instead of the work. For large articles, such as indexes or repeater racks, which are not solid, and springs, it will be found best to wax them on to a small brass block and polish them underhand, in the same manner as rollers.

TO POLISH ALUMINUM.—M. Mouray recommends the use of an emulsion of equal parts of rum and olive oil, made by shaking these liquids together in a bottle. When a burnishing stone is used the peculiar black streaks first appearing should not cause vexation, since they do not injure the metal in the least, and may be removed with a woollen rag. The object in question may also be brightened in potash lye, in which case, however, care must be taken not to make use of too strong a lye. For cleaning purposes, benzole has been found best. Objects of aluminum can be electro-plated without any difficulty, and Mouray succeeded in imparting to them a bright white luster in passing them successively through a weak bath of hydrofluoric acid and aqua fortis. The effect obtained was quite surprising, it is said.

IMITATION OF ANTIQUE SILVER.—The *Révue Industrielle* gives the following process for giving to any silver plated or silver article the characteristic appearance of antique plate. The article is dipped in a bath of water containing about 10 per cent. of sulphide of ammonium, and then scratch-brushed with a brush made of glass threads or "bristles." When afterward burnished with an agate tool, its surface becomes a beautiful dark brown color.

POLISHING STEEL.—A correspondent desires to know "What is the best mixture for white metal polisher for steel, for putting on a good black color." If the steel is of moderately good temper, use a zinc polisher with diamantine; for soft steel a tin polisher is better. The diamantine should be mixed on glass, with very little watch oil. Diamantine mixed with ordinary oil becomes gummy and quite unfit for use in a day or two, and if brought into contact with metal in mixing, turns black.

IMPROVED BENZINE JAR.—1. Take a circular piece of finely perforated metal—a copper strainer answers well. Then fit it inside your benzine glass, rivet in five or six wire feet, not more than a quarter of an inch long, so that you will have a small space between the perforated metal and the bottom of the benzine jar; half fill the jar with the purest of benzine—the spirit must be at least a quarter of an inch above the perforated metal; lay the watch plates, etc., on the perforated metal, and the benzine, which holds the thick oil and other impurities in solution, will speedily precipitate them to the bottom, and their further contact with the work is prevented by the perforated plate, and when dried, they are perfectly clean. 2. Take a small, wide-necked bottle, fit a cork, and insert a brass wire; turn up the end like a fish hook, so that it will dip half an inch into the benzine, hook on the wheels, balance, and small pieces, and immerse them in the spirit, which will operate as before described. A little attention to small tools is often the difference between a quick workman and a slow one. Workmen of equal industry and ability often produced widely different results, from the neglect of a small outlay in useful tools.

NICKEL PLATING.—The following process of nickel plating is the result of much experimenting and study, and gives perfect results every time, for small brass work or any other of the soft metals. If the work be new, it should be brought down to a fair surface with the file and fine grains of emery paper, and then finished on a felt wheel with tripoli; that prepared in cakes is the best and most convenient, as it can be held against the wheel while running, and thus the wheel will be charged without stopping the lathe. After the work has been well polished in this way, it should be cleaned in benzine or lye, to remove adhering particles of tripoli and dirt. Now the final high polish may be given with the rag wheel and rouge, when the article will be in readiness for the last and most important part of the cleaning, which is done with precipitated chalk made into thick paste, with just enough ammonia water to give it a sharp smell. Now hold the article in a pair of wooden pliers, or in any way to keep them from coming in contact with the hands, while they are well brushed over with the chalk mixture. They should then be rinsed in running water, and if there is no part that is not covered with a film of water, they are ready to be placed in the circuit as soon as possible; but if there are spots where the water does not cover the object, the work shows imperfect cleaning, and should be gone over again as before, and rinsed. The bath should be composed of sulphate of nickel and ammonia, with pure rain or distilled water, and the strength should be 70° Baumé hydrometer, or about ten ounces of the salts to each gallon of water. The bath should also be kept as near neutral as possible, by testing with litmus paper and adding small quantities of ammonia or sulphuric acid, as the case may demand. The length of time the object should remain in the bath depends on the thickness of the plate wanted, and strength of battery. A weak battery and longer exposure will give the best results. If the battery be too strong, the objects will assume a rough gray appearance.

Trade Gossip.

There is quite a boom in wedding rings.

Off-color diamonds of a pale lemon tint are coming into fashion.

Five-cent nickels of the new issue have been set as sleeve buttons.

J. J. Fisher, of this city, was recently married to Miss Helen F. McGann.

Leroy W. Fairchild will hereafter fill all orders addressed to him for McKinnon pens.

There are 896 tons of silver coins laying in the large silver vaults of the U. S. Treasury in this city.

Loque & Bard is the name of a new firm recently established in the jobbing business in Chicago.

Henry Birkett, an enterprising jeweler of Owatonna, Minn., has been elected Mayor of that town by acclamation.

In the recent railroad accident near Philadelphia, Mr. C. B. Bishop, of the firm of Carrow, Bishop & Co., was seriously injured.

Max Kuner, of Denver, Colorado, is now comfortably situated in his new store, which he has fitted up in a very tasteful manner.

Lewis Gilbert, of Greenville, Texas, was one of the victims who lost their lives by the destruction of the Ende Hotel in that city.

W. W. Oliver, of Buffalo, has just completed a very useful tool for bending ring wire that will doubtless interest a great many ring manufacturers.

Jacob Strauss has removed from 18 to 25 John street, where he will continue to present the latest novelties in watches, jewelry and kindred goods.

Czar Alexander's crown is worth 3,000,000 rubles. It is covered with diamonds, pearls and rubies, and was first used in the coronation of Catherine II.

F. W. Gesswein has recently issued an elaborate and complete catalogue of tools and machinery for manufacturing jewelers, watch case makers and watchmakers.

Our old friend, Captain E. R. P. Shurley, has once more appeared above the horizon, and, it is understood, is to be identified with a watch and clock company scheme.

Sneak thieves recently broke in the show window of Christie Scheitzer's jewelry store at East New York, and made off with several watches and a quantity of jewelry.

One of our enterprising manufacturers has started up a new line of alligator jewelry, and has succeeded in producing new and beautiful effects in imitation of alligator skin.

Chicago is about to establish a manual training school, where pupils will be taught to use the hand in the mechanical arts. The sum of \$100,000 has been raised for the purpose.

E. A. Sweet, traveler for L. H. Keller & Co., celebrated the anniversary of his silver wedding April 13. His friends congratulated him with substantial tokens of their esteem.

Owl jewelry gave place to Jumbo jewelry, and now elephants, big and little, are being driven out by pug dogs whose noses are made to curl gracefully over the tops of their heads.

Fowler Bros., of Providence, have recently patented a unique improvement in the setting of cluster jet and onyx jewelry that will add greatly to the effectiveness of this class of goods.

H. S. Brodie & Co., of Denver, are among the busiest jewelers of that enterprising town. They are enterprising, wide-awake men, and enjoy the confidence of a large clientage of friends.

Importers of diamonds have lately received advices from their correspondents abroad notifying them that rough stones have advanced twenty-five per cent. in the European markets.

Thos. Brady's jewelry store at Franklin, Ohio, was recently robbed of \$4,000 worth of jewelry. Before leaving, the thieves set fire to the premises. The fire was extinguished with small loss.

The celluloid show cases are rapidly growing in popularity. They are elegant, substantial and durable, susceptible of a high and permanent polish, and are peculiarly adapted to jewelry stores.

George W. Ludwig, of Chambersburg, Pa., has taken the advice contained in the circular recently issued by the Jewelers' Protective Union, and has bought a fire and burglar-proof safe.

John A. McCloy, of Providence, was recently given a dinner at Mouquin's restaurant by a number of his friends. The occasion was the departure of Mr. McCloy for Europe on the 20th ult.

L. Herzog & Co. are remodeling their building, and intend to make it one of the most attractive and convenient stores in the Lane. Every room is now occupied by members of the jewelry trade.

Kossuth Marx & Co., have introduced a new filled chain, consisting of a shell of fourteen-karat gold filled with silver. It is made in various attractive designs, and will, no doubt, become popular.

One of the latest and most tasteful designs in seal rings is called the "Princess." It is made in raised initial ornamentation on a curved or dome-shaped stone, and is exceedingly beautiful and attractive.

Sons of M. Eisenstadt, of St. Louis, are in the city, endeavoring to engineer a settlement of the affairs of that house. Creditors are inclined to ignore good business practices and to accept their offer.

Mr. Boynton-Kelly will assemble himself as the National Guild at Chicago on the 9th inst., where he will, doubtless, as heretofore, overwhelm his hearers with a diarrhoea of words and a constipation of ideas.

The firm name of Caleb Clapp & Co., of Chicago, has been changed to Clapp & Davies. Mr. Davies, for many years an active partner in the firm, now comes to the front and throws out his banner to the commercial breeze.

August Saltzman, for many years engaged in the importation of watches, has left the trade to engage in journalism. He has associated himself with Mr. F. Hirschy, for the purpose of publishing a Swiss paper in this city.

Frank N. Earl, for many years in the employ of Hunt & Owen, jewelers at Providence, has been arrested on a charge of stealing gold stock valued at \$3,000. The prisoner was bound over to the Court of Common Pleas.

Frank D. Barnum, of Louisville, Ky., has again come to grief. This is his second innings, we believe, and it is thought by some of his creditors that his peculiar business tactics can be better employed in some other field of industry.

In a *swell* mansion in this city is a marvelous plush-covered table, the decoration of which is a fringe of watches of every variety of date and workmanship, collected by their fair owner in Europe, and some of them priceless in value.

The latest combination carried by an enterprising drummer is rolled plate chains, sleeve buttons, and fancy flower pots. It is on a par with the cheap-John auctioneer who sells blacking, mousetraps, scrubbing brushes and other sweetmeats.

J. Wienhold has just introduced a novel watch charm cigar cutter in the form of a horse shoe, made in gold, with stone mounting. It is a neat and attractive ornament, and as useful to smokers as it is ornamental. It will, doubtless, meet with a ready sale.

Messrs. Krementz & Co. have removed to their new and spacious quarters at No. 182 Broadway, corner John street, rooms 3 and 4, with entrance and elevator on John street, and have provided a comfortable private office for the use of their out of town customers.

Colossal spiders in oxidized and illuminated silver are the correct thing for shawl pins. Some ladies wear them on the left breast as a simple ornament, to the disfigurement of a number of demonstrative young men. Several engagements have been broken in consequence.

F. P. Locklin, manufacturer of gold and silver-headed canes and bracelets, offers many new and attractive styles in these goods, at prices that will tempt purchasers. Mr. Locklin is a thoroughly practical workman, and all goods manufactured by him will bear the most critical inspection.

Frank Collingwood, who was formerly in the jewelry business at Elmira, is now one of the engineers of the Brooklyn Bridge, and has contributed materially to the success of that structure. Mr. Collingwood is a graduate of Rensselaer Polytechnic Institute, where he became an expert engineer.

The recent fire in the New Haven Clock Co's factory at New Haven, Conn., destroying a portion of the building, will, it is thought, cause no serious interruption to their business. All orders will be filled with accustomed promptness. The loss is estimated at from \$20,000 to \$30,000. Fully insured.

The Assembly has passed the Swartz Pawnbrokers' Bill, providing that hereafter the license fee for conducting a pawnbroker's business shall be \$500 instead of \$50, as now the rule, and directing that no sales shall be made of unredeemed pledges unless after advertisement. This last provision is in the present law, but is more honored in the breach than in the observance. It is expected that this increased license fee will have the effect of closing up a number of fences where stolen property, especially jewelry, is now sold *sub rosa*.

A typographical error in the advertisement of Messrs. Smith & Knapp in THE CIRCULAR of last month made us state that they dealt in gold and plated pencils instead of gold and plated jewelry. The fiend of a compositor who transformed jewelry into pencils has expiated his offence, and the Coroner has pocketed the customary fee.

Irregularities have been discovered in the Philadelphia Custom House, some employee therein making copies of invoices received by importers and selling them to competitors. This is a serious matter for the importers, and the Secretary of the Treasury has been asked to make an investigation with a view to discovering the culprit.

Prince Leopold of Hohenzollern, brother of the Duchess of Connaught, has been apprenticed to learn the trade of locksmith, in accordance with the custom of the Royal family of Prussia. In case Royalty should be overthrown in Germany he would find the knowledge very handy, as he could then go burgling jewelry stores in the country.

A Chicagoan owns the first penny coined on American soil. The device upon the old red cent is a device with "Fugio" on the left, and 1787 on the right; a meridian sun and "Mind Your Business." Reverse thirteen circles linked together. In the center "We are One," and around it "United States." Mr. Cobb, the owner, has refused \$50 for the old coin.

The assignees of A. H. Fisher, of Springfield, Ill., offer for sale the entire stock, store furniture and fixtures formerly owned by that gentleman. Bids for the whole or portions of the inventory are invited to be sent to Elon P. House or Louis H. Licknor up to noon of May 12. All offers are subject to the approval of the Court. The last heard of Mr. Fisher he was basking in the sun at Atlanta, Ga.

The retail trade is threatened with the infliction of a catalogue to be issued monthly. An enterprising crockery and plated ware dealer in Chicago has conceived the brilliant idea of getting out a catalogue and securing for it the advertisements of several members of the jewelry trade, who will thus defray the cost of circulating the crockery and plated ware dealer's advertisement. What has the retail jewelry trade ever done that it should suffer this infliction?

A bright detective in the south fancied he had obtained a trace of the goods stolen from Stephen Thomas, of Charleston. They were in possession of a woman in Macon, and the detective lost sight of them while he went to obtain a warrant for the arrest of the woman. When he returned with the required legal document there was a case of mysterious disappearance, as the goods could not be found. The detective is now waiting for the woman to bring them back to him.

A drummer for a New York House has been making himself obnoxious in this state by selling watches to dry goods men and other outsiders. The chances are that when he visits the places again where he has indulged in this uncommercial business, he will receive a warm reception at the hands of the trade. It is only drummers for irresponsible houses that do this contemptible business, for no respectable traveler will lend himself to such unbusinesslike proceedings.

Much complaint again reaches us regarding the catalogue and price list nuisance, retailers asserting that they receive on the average about ten pounds a day of literature of this kind, and they have no doubt but outsiders are similarly afflicted. They do not object so much to the catalogues, but when the prices are given so that all the world may read, it necessarily raises their ire. A Cincinnati house is acquiring considerable notoriety for the promiscuous manner in which it sends out catalogues and price lists to consumers, showing that they are making a direct bid for the retail trade to the prejudice of the retailers.

Some members of the trade have recently experienced considerable annoyance in connection with the use of a check-perforating stamp, designed as a protection against the alteration of checks. After purchasing the stamps from peripatetic salesmen, who go about from one business house to another, the purchaser is notified that in using the stamp he is infringing upon the rights of a company claiming to own the patent, and who demand a royalty of \$20. Several firms have paid this demand and costs, amounting in all to some \$30, rather than contest the matter in the Courts. But the claims for royalty became so numerous, that the trade has determined to resist further demands of this character, and are now prepared to contest in the Courts their legality. Business men outside of the jewelry trade are also prepared to resist these demands for royalty, and persons who have been called upon to pay them would do well to consult Shattuck & Binger, No. 20 Spruce street, before handing over their cash to the claimants.

E. W. Reed, of Fort Collins, Colorado, is one of the pioneer settlers in that region, and has built up a very successful business. He started with a small capital as a practical jeweler and watchmaker, but finding comparatively little trade, he added stationery, musical instruments, etc., to his stock, making his store the most attractive in the town, and by this means has built up a thriving business. He is now regarded as one of the most prosperous merchants in that locality, and has recently extended his business by making extensive additions and improvements to his store. By diversifying his stock he has avoided outside competition.

Another attempt to rob the jewelry store of T. & E. Dickinson, of Buffalo, was made a few days since. A sneak thief entered the store and asked to look at some diamonds, which were shown. After he had selected one, a confederate tapped on the window outside, whereupon the thief grabbed the tray and started to run. But Mr. Dickinson had also observed the signal from the outside, and started for the door, just in time to seize the thief by the coat tail. A struggle ensued; during which the contents of the tray were scattered on the ground. The thief finally escaped minus his hat, and Mrs. Dickinson succeeded in gathering up all the scattered diamonds, which were valued at \$8,000. Two policemen were in sight at the time, but the thieves escaped.

The Swiss Benevolent Society of this city, having taken the necessary action to authorize the building of a home for destitute and deserving Swiss located in this vicinity, or who are coming from the old country, has appointed a committee of prominent business men to solicit subscriptions to a building fund. Several members of this committee are identified with the jewelry trade, and have heretofore been prominent in charitable works of all kinds. They now ask contributions from the trade to further this most worthy object. As there are, doubtless, many among our readers who will be glad of an opportunity to aid in the good work, they are respectfully requested to send their subscriptions to J. Eugene Robert, 30 Maiden Lane, or to the office of THE CIRCULAR.

C. W. Little, of Denver, was the victim of sneak thieves recently to the amount of about \$13,000. A man and woman, elegantly dressed, entered his store and asked to look at some diamonds. They were very anxious to match a very handsome stone that they exhibited. Mr. Little was thrown completely off his guard by their manners, and freely showed them his stock. After some parleying, they concluded to look further, and departed. When he came to return the diamonds to the case, Mr. Little found one package was missing. It contained stones valued at about \$13,000. No clue to the thieves has been found, although detectives have a "theory" that the robbery was perpetrated by experts who they claim to know well, and regarding whose exploits they relate the most sensational stories.

Geo. W. Chatterton, Jr., and J. C. Klahoff, of Springfield, Ill., have united in a circular protesting against the acceptance by the creditors of A. H. Fisher of that city, of the offer he has made to compromise his indebtedness at thirty cents on the dollar. They say: "We cannot purchase goods at regular trade prices, and honestly and successfully compete in the sale of them alongside of the man to whom you sell at 30 cents on the dollar, and to further say that we shall not knowingly purchase goods from any house that accepts the settlement proposed by A. H. Fisher, unless they will sell to us at a like discount. We do not say this as a threat, but as the expression of our opinion of fair dealing." This is a fair, business-like view to take of the case, and one that should be borne in mind in all cases of compromise. Honest dealers cannot compete with men who do not pay fair prices for their goods, and it is an injustice to them every time a stock of goods is put upon the market by this means, at less than its market value.

A New Orleans bank was recently robbed of several thousands of dollars, and the Chief of Police telegraphed to the Mobile Chief to arrest two well-dressed, good-looking men who were on the train bound for the latter city. The Mobile Chief, with two detectives, boarded the train in the suburbs of that city, and picking out the two best-looking passengers, informed them that they were under arrest. They appeared a little flustered, and one of them said, "Oh! give us time to get off the train and we will take out our licenses." They were hurried to the police station, where they expressed amazement to learn that they were arrested for the robbery of the New Orleans bank. Then they bethought themselves that it was time to prove their respectability, so they sent for members of the firm of Leinkauff & Strauss. These gentlemen, on their arrival, at once recognized the suspected prisoners as J. C. Andress and Louis L. Schloss, well-known travelers for prominent New York jewelry houses. They had been arrested for their good looks and good clothes. Moral—when you rob a bank wear your old clothes, so as not to get respectable people into trouble.



VOLUME XIV.

NEW YORK, JUNE, 1883.

No. 5.

THE JEWELERS' CIRCULAR AND HOROLOGICAL REVIEW

*The recognized organ of the Trade, and the official representative of the
Jewelers' League.*

A Monthly Journal devoted to the interests of Watchmakers, Jewelers, Silver-
smiths, Electro-plate Manufacturers, and those engaged in the
kindred branches of art industry.

SUBSCRIPTION:

To All Parts of the United States and Canada,
\$2.00 Per Annum; Postage paid.

To Great Britain, France, Switzerland, Germany, the West Indies, Mexico, the
Republics of South America, and Australia, \$3.00 per annum. Postage paid.

*All communications should be addressed to D. H. HOPKINSON, 42 Nassau
Street, New York. Advertising rates made known on application.*

Retail Dealers and Outsiders.

THE CHIEF complaint of retail dealers of late years has been that manufacturers and jobbers persist in selling goods to outsiders at the same prices they charge the regular dealer, thus encouraging an illegitimate competition. The fact that these complaints grow louder and louder year by year is conclusive evidence that the evil is a growing one. In the May number of THE CIRCULAR we discussed this question to some extent, and have been commended by the best men in the trade for touching upon a subject so unpalatable to the retail dealers. There is no disguising the fact that outside dealers have become exceedingly formidable competitors for the retail traffic in jewelry. He who shuts his eyes to this fact is blind to his own interests. It is also equally true that many of those manufacturers and jobbers who formerly sold only to the regular retail dealers, are now soliciting the patronage of dry goods merchants, fancy goods dealers, dealers in furnishing goods, and, in short, of every outsider who chooses to carry a line of jewelry in stock and can pay for it. We have contended against this earnestly and persistently, but the tide has set in that direction and is too powerful to be stemmed at present. We regard the retail dealer as the natural ally of the manufacturers and jobbers, necessary to the success of their business and entitled to their protection. Instead of this we find them arrayed in hostility to the dealers, and furnishing their illegitimate competitors with a club to beat their brains out with. We recognize the inevitable in this, and, being powerless to check the evil, must be content to look for the cause of it and to suggest means whereby the dealers may protect themselves.

The outside trade is in obedience to a public demand for it. Without such a demand it could not exist. The public demands free trade in jewelry, and will buy what it needs in the cheapest markets. Outsiders handle jewelry not for the profit they make upon it but as a "leader" to attract attention to their other goods, upon

which they do make a profit. It is to their interest to sell as much jewelry as they can, and as low as they can, for the sole purpose of bringing customers into their stores. So they buy liberally, pay promptly, and keep their stock moving. The regular dealers having nothing else to depend upon must make sufficient profit on their sales of jewelry alone to pay their expenses and give them a living. They are harping upon one string, while the outsider has a full orchestra, and plays his various instruments to suit the public fancy. He is the true merchant, catering to please his customers in every way, and offering them decided bargains in one line and charging enough in another to make a fair average of his profits. As a rule, retail dealers in jewelry are neither good merchants nor trained business men. In the smaller towns and villages most of them are practical watchmakers, combining watch repairing with selling jewelry. They work at the bench themselves, and become so absorbed by the work they have in hand that they are unfitted for the task of waiting on customers. In fact, the duties of a practical watchmaker and those of a successful salesman are incompatible. When the workman is called from the bench—where he is absorbed in a job that interests him and commands the exercise of his best mechanical faculties—to show goods to a possible customer, his mind is unfitted for the task, and he lacks that complaisancy of temperament and suavity of manner that are essential qualifications in a successful salesman. A workman recently told us his experience in this respect, which will serve as an illustration. He opened out as a retail dealer in a country village with the firm conviction that honest work and "square" goods would win success for him. But he struck the wrong community. Shortly after he had arranged his stock he was called from the bench to show some watch keys. His customer delayed him ten minutes, and finally purchased a key and paid five cents for it. The workman returned to his bench and was immediately absorbed in an intricate case of damaged watch. A head is stuck into the door and a voice exclaims, "Got any watch keys?" Again he turns salesman, and at the end of quarter of an hour has sold another key and pocketed another five cents. Once more he returns to his work, only to be again interrupted by a call for watch keys. Having supplied this customer, and thinking that community must run solely to watch keys, he set the box containing them where he could reach them without leaving the bench, and returned to his favorite occupation. Again the door opens and a voice begins, "Have you got ——" "Yes, there they are, help yourself," exclaimed the irritated shopkeeper, chucking the box of keys towards his visitor, and going on with his work. The gentleman so abruptly accosted turned on his heel and left the store. The jeweler was disgusted subsequently to learn that this was the superintendent of a railroad in search of half a dozen watches for employees of the road, and that he had bought them at another shop. As a workman his irritation at being interrupted was natural, but as a salesman his anger was impolitic. It is because practical workmen undertake this double duty, working at the bench and selling goods, that they are not successful as salesmen. They lack the *suaviter in modo* that

enables a successful salesman to show goods all day and smile insinuatingly upon every comer, whether they buy anything or not. As a matter of fact, the most successful men in the trade are not practical jewelers or watchmakers, but are trained merchants and business men, while the majority of good workmen are unsuccessful when they attempt to become salesmen. They may be able to repair the works of a watch to a nicety, but they have not the tact to please customers. It is because the outside dealers are merchants and nothing else, seeking only to please the thousand and one whims of their patrons, that they are successful and formidable competitors of retail dealers.

Another evidence of the lack of business training of a majority of retail dealers is their manner of treating their creditors. In the first place they are not judicious buyers, but frequently overstock themselves with a surplus of goods that become unsalable on their hands. They are careless of their credit, and when they give a note for sixty days spin out their time to ninety days or four months, and never let it worry them. They ask for time to make their payments and take eternity to pay it in. The outsider, on the contrary, buys judiciously, pays cash, or never asks more than thirty days, and, being a business man, appreciates the fact that his credit is his capital, so is careful to provide for his paper at maturity. A manufacturer remarked to us a few days since that he had "never been left in a hole by an outsider yet, while I've lost a fortune by the regular dealers." This same gentleman said that Macy bought more goods of him each month than all the retail dealers within a hundred miles of New York combined, and while Macy paid cash on receipt of bill, the retailers invariably asked four months time, and many of them would then want an extension. What is true in New York is true in other localities—the outsiders are successful because they are merchants and shrewd business men, catering to the demands of the public, while the retail dealers, as a rule, are excellent workmen but not merchants. Manufacturers and jobbers will sell to those who patronize them most, and will give the best terms to those who are the best pay. This is in accordance with the immutable laws of supply and demand, and all the buncombe of state association resolutions or of disgruntled dealers will not change the fact. In obeying these laws the manufacturers and jobbers are doing on a large scale precisely what the retail dealer does on a small scale when he makes a discount for cash or gives special favors to his best customers. It is human nature to do so, and it will be done as long as there is any human nature left.

The time has passed when the retail dealers can lean with reliance upon the manufacturers and jobbers and expect their aid in controlling the retail trade. That trade is rapidly cutting out other channels for itself, and the manufacturers and jobbers must follow the channel. If the regular dealers want their share of it they must place themselves in the current and float with it, and not try to row against it. They must either absorb the outsiders or be themselves absorbed. They must give up the idea of making a specialty of dealing in jewelry, but study to become merchants in the full sense of the word, and cater to the demands of the public, whatever they may be. There are many reasons why the retail trade has drifted away from the regular dealers and into the hands of the outsiders. Probably the promiscuous sending out of catalogues and price lists by a certain class of jobbers did more than any one thing to bring about the result. These made it possible, for whoever chose to do so, to buy goods at retail at the same prices the retailers themselves could. Keen merchants in outside callings were quick to see that a line of jewelry would be a good advertisement for them, and that using it as such they could afford to undersell the regular dealers. When one started in the door was opened, and whoever chose could follow. Then, too, the great diversity in manufactures made it necessary for the manufacturers to have a more extended outlet for their products, and the public demanded increased facilities for buying them. For instance, the changes in fashions have brought forth endless varieties of scarf pins, sleeve buttons, collar buttons, etc., till the

old style of pearl shirt buttons have been virtually driven from the market. The public demanded that the sellers of shirts, collars, cuffs, scarfs, etc. should also supply them with pins and buttons, so that the gent's furnishing goods stores were really forced to carry lines of these goods. With these as an entering wedge it was easy for these outsiders to go more extensively into the jewelry business, adding watch chains, finger rings, watch charms, and even watches to their stocks. We know of some "shirt men" who do a good business as diamond brokers, disposing of many diamonds set as studs, scarf pins and rings in the course of a year to the customers who buy shirts, scarfs and collars of them. Other causes, combined with these, have served to make serious inroads upon the legitimate traffic of the retail dealers, and we see no way left for them to secure their share of trade but to retaliate by becoming merchants themselves, diversifying their stocks, making them attractive, and supplying the public with what it wants, be it fine jewelry, shirts and collars, or perfumery, pomades and hair dye. Let them educate themselves as business men and enter into the competition with energy and enterprise. They must either do this or see their trade absorbed by the outsiders, while they are left to do watch repairing, and sink to the level of the shoemaker and the blacksmith. But the watch repairer, who works hard at the bench and ekes out a livelihood by an occasional sale of jewelry, says, "How am I to get the goods with which to set up a diversified stock?" The fact that he asks such a question is an indication that he is not imbued with the tact of the modern progressive merchant. In these days of over-production and unlimited credit, any man of good standing in his community, who can give good references as to his moral character and industry, will have little difficulty in getting what goods he needs. Let him begin to branch out in a cautious, limited manner until he gains confidence in himself and feels the pulse of his patrons, expanding his business as his needs require. But make a beginning, and show your fellow citizens that you do not propose to play the role of the sluggard in these days of push and enterprise. But if you have not confidence in yourself, and are afraid to extend your business, do not whine and complain because some more enterprising person grasps the opportunity you refuse to see. We cannot all be Vanderbilts or Jay Goulds, but that is no reason why we should envy those who can be. This is a pushing, progressive age; business is not conducted to-day as it was fifty, twenty or even ten years ago, and he who fails to become imbued with the prevailing spirit will be left behind in the race. State associations and envious, selfish threats can do nothing to help the retail dealer. He must put his brains and all his physical energies into his business, and meet competition with competition. The catalogue business has done its work of demoralization, and it is useless now to repine. Look the situation square in the face, and nerve yourself to win, single handed and alone, in a fight where little help can come to you. The fight of the retail dealers is with competition outside of the trade, and not with the manufacturers and jobbers inside of it. While the facts we state may be unpalatable to retail dealers, and are entirely contrary to what we could wish, they are, nevertheless, "frozen facts" that each retail dealer in the land must be prepared to confront for himself. They can no longer rely upon the manufacturers and jobbers as a class, for these will sell their goods in the future as they have been doing in the past, to whoever pays best, be he a regular dealer or an outsider. State associations, managed by a few scheming men for their own personal glorification, may issue their denunciations and pronouncements, but they will no more stay the onward course of trade than did the Pope's Bull arrest the vagrant comet.

Frontier Jobbers.

AS THE country has developed, and the frontier steadily pushed forward towards the Rocky Mountains, there have sprung up from time to time large cities that have been great commercial centers, served their purposes as such, and then relapsed into solid,

substantial, steady-going, conservative communities, generally possessing great wealth, but lacking in that irresistible spirit of enterprise that was so essential to their early growth. Men who are not yet old remember when Buffalo was the pivotal city whence Ohio and Michigan—the then Great West—drew their supplies. Then Detroit and Cincinnati had a rapid and flourishing growth as commercial cities, eventually to be superseded in that particular, to a considerable extent by Chicago. Cincinnati has never lost her commercial characteristics entirely, for the reason that her position has made her a feeder to the Southern States, but the frontier, or advance line of civilization, has pushed way beyond her. St. Louis should have been another of these great pivotal cities, but the tidal wave of emigration and development swept over her while she was asleep and she has never been anything more than a jog-trot old foggy city. Occasionally she has awakened to a spasm of enterprise, but was so astonished to find herself with her eyes open that she has quietly dosed off into slumber again. For twenty-five or thirty years Chicago has been the great commercial center of the expanding enterprise of the West, and by the energy and enterprise she has shown in the past, has richly earned the wealth and laurels she is likely to have leisure to enjoy in the future. Within the past few years there have sprung up beyond Chicago, but still in rear of the frontier, several young and ambitious cities that propose to divide with Chicago and each other the honor of catering to the still developing Great West. St. Paul and Minneapolis now virtually control the traffic in that rich and populous section of the northwest that was a trackless wilderness twenty years ago, while Denver, Kansas City and Lincoln, Nebraska, aim to supply the immediate west and southwest. These are now flourishing cities, containing the same class of enterprising adventurous spirits that laid the foundations of Buffalo, Cincinnati and Chicago, and they will be developed in substantially the same manner. Already they boast of wealthy jobbing houses in almost every branch of trade, while manufacturing industries are fostered and encouraged in every possible way. These jobbing houses supply the retail dealers beyond them with goods at the same prices Chicago would, and they are saved much expense by dealing with them. Chicago must expect, therefore, to see most of her jobbing trade depart from her in the future, and the trade of the different western sections center in the cities built up by these sections. Nor is she likely to have the honor of supplying the jobbers in those sections with goods, for, as New York is the center for manufactures, the western houses will make their purchases here. This is especially true of the jewelry trade, for the great manufacturers of Providence, Attleboro, Newark and New York make their headquarters here, whence their goods are distributed to all sections of the country. Buyers from St. Paul, Minneapolis, Denver and other jobbing centers in the west come through Chicago every year to buy goods in New York, where they can purchase as cheaply as the Chicago jobbers themselves can. That this trade is largely increasing year by year is shown by the fact that while our old established houses are constantly increasing their business, new firms are continually springing up who also do a good business. They absorb simply a portion of the excess of trade over former years. The buyers for these western jobbing houses are sharp, shrewd business men, who have no idea of paying a profit to the middlemen of Chicago, but prefer to deal directly with the manufacturers. New York must always be the great central headquarters of the jewelry trade for a variety of reasons: First, here is centered more wealth than in any other locality on the continent, and wealth is always an incentive to the development of art and articles demanded by the luxurious tastes. Secondly, New York is the great commercial seaport of the country, and naturally the home of the importers who bring to us millions of dollars' worth of foreign made goods annually. Thirdly, labor in the east is cheaper than in the west, and manufacturers are forced by excessive competition to buy labor at the lowest possible rates. This fact will make New York the headquarters of the manufacturing jewelers for many years to come, for

in this city there is always a surplus of labor. Then, too, the jobbers of New York sell only to retailers except in the city; here many of them supply the outside trade but not the outside trade in the country. They are not competitors of retail dealers in the retail field as so many of the Chicago jobbers are. Outsiders, it is true, buy many goods in New York, but they do it mostly through the city outsiders who do a wholesale business, as most of the large bazaars do. There are various other reasons that will readily suggest themselves why these thriving western cities will buy in New York in preference to Chicago, and unless the enterprising men of that city devote more attention to building up their manufacturing interests, they are likely to lose a goodly portion of their jobbing trade. Of course, she will never be the old foggy that St. Louis is, because there is too extended a country, filled with enterprising people, within the radius formed by the western cities we have named for her to cater to, but she cannot count longer upon supplying the enterprising jobbers of those cities. In this respect Chicago has seen her palmy days. We do not say this in any carping spirit, for we are too familiar with the enterprise of the business men of Chicago, who have made of that city a marvel of the world; New York owes to her too great a debt of gratitude for the wealth she has annually poured in upon us to ever envy her success or to rejoice in any misfortune that might overtake her; but we point out what is already in progress, and in doing so would direct attention to the necessity of her devoting herself more earnestly to manufacturing. In the jewelry line there are some things that can be done to advantage in Chicago equally as well as in the east, and this fact should be taken advantage of. Why should the great and enterprising houses of Chicago be so dependent upon eastern manufacturers when they have the facilities at hand for making a portion, at least, of their own goods? By doing so they will excite no envy here, for the constantly increasing demand for goods will provide a market for all. It is inevitable that the great cities growing up beyond the Mississippi will control the jobbing trade of that section, and that trade will be supplied by those manufacturers who can do it best and cheapest. New York will always have an advantage over Chicago in the manufacturing line in some important respects, but there is no reason why she should not share with Chicago a portion of her honors. We commend these suggestions to the enterprising men in the trade in that city.

The New Haven "Painted Diamond" Case.

A CASE OF some importance to the trade has recently excited considerable public attention because of the sensational reports of it in the daily papers. These facts may be briefly stated as follows: Jacob Nepel was charged with obtaining by false pretenses \$625 from Edward Engel, a pawnbroker, by means of several diamonds which the buyer took to be old mine stones, but which, when washed with soap and water, proved to be of the Cape variety. The diamonds had a fixed and actual value, and were sent from New York to Mr. Nepel to sell. He placed them in the hands of Martin Gunn, who in turn transferred them to Charles Dorman, the young man who took them to Engel. In speaking of the ear and finger rings, Mr. Nepel said to Mr. Gunn: "Those diamonds would have cost \$700 at Tiffany's." This was repeated by Gunn to Dorman and by him to Engel. Dorman also said to Engel: "Unless you give me the price I ask, \$625, I will take the stones to New York, where I can sell them for more money." There was no evidence to show that either Nepel, Gunn or Dorman represented the stones to be of pure water and old mine diamonds, or made any other representation regarding them. Engel bought the stones entirely on his own judgment. They looked like valuable gems, having a rich bluish tint, resembling old mine diamonds. After having purchased them Mr. Engel brought them to New York, and sub-

mitted them for valuation to Mr. Heller, of Heller & Bardel, who is an expert diamond dealer. The stone shown was set in a ring, and but a small portion of its surface visible, yet Mr. Heller immediately saw there was something wrong about it. He said, "If this stone was not stolen and is not painted, I will give \$1,000 for it." On examining it closely, however, he pronounced it to be a Cape diamond, painted to resemble an old mine stone. He finally said to Mr. Engel, "If you will let me wash this with soap and water, I will show you whether I am right or wrong." After some hesitation, permission was given him to wash the stone, and, as he had predicted, it proved to be an inferior diamond, colored, or, as the trade knows it, painted. Thereupon Mr. Engel had Mr. Nepel arrested for obtaining \$625 by misrepresentation. The case was tried at New Haven last month, when Nepel was acquitted. The court found that there was no evidence to show that Nepel knew that the stones were painted, or that he painted them himself, and that even if he had known their true character, there would not be sufficient ground, under all the circumstances of the case, to cause his conviction. In conclusion, the Judge said: "If a seller knows of a defect in his goods and does not reveal it, he may be and probably is guilty of a moral fraud, but this moral fraud has not yet grown into a legal fraud. There must be active fraud, for the law does not compel a seller to disclose all that he knows; if it did it would sap the foundation of trade. So far as appears from the testimony, Mr. Nepel did not know that the diamonds were to be sold to Mr. Engel; he gave no directions as to whom they should be sold to. Admitting them to be painted, this painting did not add to the price received, although it may have helped the sale. In this view of the case, Mr. Nepel is no more censurable than other merchants, who, by means known to themselves, make their goods look as well as possible while selling at a fair price. The accused is discharged." The reporters for the daily press have found in this case material for several sensational articles; representing that the market was being flooded with "painted diamonds," and thus doing their utmost to excite distrust of all diamonds in the public mind. The trick of painting diamonds has been known for many years, and that they have not been used to deceive buyers is evidence of the fact that they cannot pass scrutiny with experts. This was illustrated by the readiness with which Mr. Heller detected the spuriousness of the New Haven stones as soon as he saw them. As the public buys its diamonds generally of reputable dealers and experts, there is no danger whatever of their being imposed upon with spurious stones. If, however, a person who deems himself particularly shrewd and "cute" buys stones of unknown and irresponsible outside speculators, and trust to their own judgment to get the best of the bargain, they are liable to be deceived with either painted or paste diamonds, or "veneered" stones, or any other cheap imitation of genuine gems which are always to be found in the market, but which ordinarily sell for their true value. The unwarranted prominence given to the case we have quoted, warrants this extended notice, in order that the public may be assured that the intimation that "the market is flooded with painted diamonds" is the veriest sensational bosh, simply because there are too many expert diamond dealers watching the market to permit even one to pass them undetected. If diamond buyers will deal only with legitimate diamond merchants, they will be in no danger of being deceived, but if they go into the by-ways looking for "a big thing in diamonds," they are liable to be taken in and done for, and the fact that they come from the State of wooden nutmegs will not save them from adventurers and sharpers.

eradicated. Yet probably few dealers are aware how these catalogues are usually prepared, or the relative interest that manufacturers and jobbers have in them. Of course, some of them are genuine documents, prepared solely in the interest of the jobber who circulates them, and who alone pays for them, but there are others got up in a manner that savors more of blackmail than of legitimate business enterprise. A jobber conceives the idea of getting out a catalogue, and the first thing he does is to figure the cost. He finds it an expensive luxury, for paper and printing represent costly labor that must be paid for. So he goes to the manufacturers of whom he buys goods and requests in terms that sound more like a demand, that they shall assist him by being represented in his catalogue. He represents that it is to have an extensive circulation exclusively within the trade, and the advantage a display of his cuts will be to the manufacturer. By his persuasiveness, and the implied if not spoken threat that he will not buy goods of any manufacturer who refuses him, he obtains \$200 or \$300 from each, according to his claims on them. Other manufacturers also furnish him with cuts to illustrate their goods, and thus armed he proceeds to issue his catalogue. Of course, it is mainly an advertisement for himself, and the only benefit the manufacturers derive from it is the orders they may receive through him. Indirectly they may reap some benefit in this way, but none whatever in a direct manner as they would if advertising in the legitimate journals of the trade. As a result, they have the pleasure of paying for the circulation of the jobbers' advertisement, while he reaps all the advantage of it. They have the satisfaction of playing the role of tail to his kite. This speculation in catalogues has been carried to great lengths, and manufacturers have been sorely victimized by it. One enterprising western jobber is reported to have carried it so far that the profits he has made in publishing catalogues has enabled him to build a \$10,000 house. Retail dealers will see from this that they have not been the only sufferers from the catalogue nuisance. But manufacturers are getting tired of this style of business, and a number of them absolutely refuse to advertise in any catalogues on the very just ground that they can reach the trade they cater to more directly by patronizing the trade journals. Besides, retail dealers do not want catalogues from jobbers. When they receive one they are always suspicious that their neighbors, the butcher, the baker and the candlestick maker, have been equally favored, and that their custom will be transferred from him to the jobber. Traveling salesmen from the jobbing houses visit the retailers often enough to keep them posted as to styles, prices, etc., and they prefer to deal with them than to trust to a printed catalogue that gets stale in a few weeks. In every aspect in which it can be viewed, the jobbers' catalogue is a nuisance, and calculated to do more harm than good to the legitimate jeweler.

* * * * *

While on the subject of catalogues and advertising, we beg to warn the trade against the thousand and one new schemes that are concocted by clever adventurers to wheedle them out of their money. This is the season when they are concocting their plans for the fall campaign, and the advertising solicitors are out in full force. Each has the best scheme for advertising ever conceived of, and is lavish in promises as to how he will put every advertisement directly before the eyes of every American citizen, native born or adopted. One has a cheap clock that he proposes to put in railroad stations and other public places, that has a trick, every time it strikes, of ringing a bell and turning a large wheel that brings the advertisements alternately into view. Another has a collection of very handsome engravings that he proposes to put in book form with advertisements inserted between them. Then there are summer resort guide books, railway guides, telegraph and express station guides, to say nothing of the special papers of kindred trades, all seeking to delude the unwary jewelers into advertising. The trouble with these catch-

THE CATALOGUE business has been a source of unending annoyance and complaint, and their general circulation among outsiders, accompanied by price lists, has worked such demoralization among retail dealers that the effects of it will probably never be

penny affairs is that they have no legitimate circulation whatever, and none, consequently, that is of any value to the trade. The jewelry manufacturers and jobbers want to reach a special class of dealers, the men who buy their goods, and money spent for advertising in railway stations and cheap restaurants might as well be thrown in the East river for all the good it does them. We know of one of these schemes, a book handsomely illustrated, to which some in the trade paid large sums for advertising, that never circulated a hundred copies. Their plan was to put in type all the advertisements they obtained and bind up one or two copies for each advertiser, and this was all the circulation the book received—it was simply an exchange of cards among advertisers. We know of another guide book scheme that has existed five or six years and never had a bona-fide circulation to exceed one thousand copies, and these mostly went to beer saloons. The proprietor made his profit out of his gullible advertisers. The jewelry trade is well supplied with journals devoted to its interests exclusively, and whose business it is to place their papers in the hands of every person connected with the trade. Of course, this is an impossibility, but they come as near to it as is possible. There can be no better mediums for reaching the men who buy jewelry, for men who do not have the time or inclination to read the papers want them for the sake of the advertisements. As this paragraph is written from the business end of THE CIRCULAR, we say nothing of the value to the trade of the reading matter it contains each month, but if any reader has a doubt of our veracity when we say that THE CIRCULAR reaches more members of the trade every month than any firm can possibly do by letter or private circular, our subscription books are open for his inspection. We will show him a list of names in the trade more numerous than he ever dreamed of. But it was not our intention to exalt our own horn, but simply to warn the trade against the horde of hungry advertisement solicitors for intangible schemes who are now on the war path.

Electro-Gold and Silver Plate.

BY JOHN W. MILES.

Continued from page 105.

ANOTHER question often asked is, "Why does silver tarnish?" It was for a long time a popular fallacy that tarnishing was due to the poor quality of the silver used, the fact being exactly contrary. It is even yet believed by many that tarnish is produced by the oxygen in the air, but pure oxygen has no such effect and will not voluntarily unite with silver except at the melting point, leaving it at the moment of solidification. If silver could be kept in a cold and dry place from which the air is absolutely excluded it would retain its luster for an indefinite period. The great foe to its brightness is sulphur, for which it has an unusually powerful affinity.

A gentleman, having purchased an ice pitcher, returned it after a few months "as black as a crow," and indignantly demanded the return of the money paid for it, as the silver had disappeared. He stated that it had never been used, but had been securely wrapped in a white cloth and stored in a closet. The cloth covering was bad enough, since acid is nearly always used in the bleaching process, but additional inquiry elicited the fact that sulphur matches were also kept in the same closet. The pitcher was cleaned in the presence of the gentleman, and as the bright silver was revealed beneath the tarnish his amazement was very amusing. He realized the fact that silver, like brains, to be kept bright should be used.

The formation of tarnish is very simple. The use of coal fires, especially bituminous coal, and the burning of gas, creates in the atmosphere a considerable quantity of sulphuretted hydrogen (H_2S). This gas coming in contact with the silver, a chemical action takes place; the two atoms of hydrogen being released and replaced by silver, forming the sulphide of silver (Ag_2S). The amount of silver

thus transformed into a sulphide is so exceedingly small as to be almost microscopical, yet sufficient to change the color and produce the tarnish. It is easily removed, but with a new exposure to the gas a new sulphide is formed, hence silver requires constant care to keep bright. A great number of experiments have been tried to prevent tarnish, but no practical process has as yet been discovered to permanently overcome this invincible law of nature. Certainly the tarnishing of silver *not in use* can be prevented by painting with alcohol in which some collodion has been dissolved. The collodion forms a thin transparent film upon the silver, keeping it from the air and protecting it from all effects of the sulphuretted hydrogen. A hot water bath will remove the collodion at any time. For obvious reasons, however, this recipe is not applicable to articles in daily use, and the only resource is to adopt the best methods of cleaning. Numerous preparations for the purpose are in the market, each claiming to be the best. Without discussing their relative merits, it is important that, whichever may be used, it should be absolutely free from grit or acid. If the tarnish is recent and slight the moisture of the breath, quickly followed with the brisk application of a soft and slightly rouged chamois skin, will usually suffice. If more severe measures are needed, either of powder or liquid, it should be applied with a piece of soft flannel, and the article finished as first stated. Where large quantities are to be kept in order, as in stores, hotels, clubs, restaurants, etc., the following solution will be found very useful and convenient. Dissolve in a crockery jar one-half pound each cyanide of potassium and salts tartar in one gallon of soft water. Dip the articles in the solution for a *few seconds only*, wash immediately with clean hot water, and wipe dry with a soft towel or chamois skin. Great care must be taken with this solution as it is a *deadly poison* when taken into the stomach.

A tour of inspection through the different departments of a large manufactory of electro-plate, following the processes that transform the crude metals into beautiful and useful articles, is as full of interest to the expert as to the novice. From the storeroom of metals, piled bar upon bar in countless numbers, we pass into the mixing room, where huge kettles of molten metals seethe and simmer. Ask all the questions we may, the one solitary genie of the caldrons has no reply. The different ingredients which are here blended into one, the properties of the sacred "hardening material," and its proper proportions to the bubbling mass, are veiled mysteries. Recast into bars the alloy is again remelted in the casting room, to insure with certainty an even and perfect mixture. Many of the most elaborate pieces and figures are produced in this room by moulding. In the larger articles "cores" are used, mostly sectional, in order that they may be easily removed after the metal cools, but for the smaller pieces, such as handles, tips and many ornamental trimmings, the following process is employed: As the metal in the mould cools and hardens at its outer surface, the center, which is still hot and in a liquid form, is quickly poured out, thus leaving the casting hollow and light without decreasing its strength. This process is an American idea, and has been in use for many years. In this room also are the ponderous rolls that, grasping the flat bars of metal, reduce them to large sheets of requisite thickness for future cutting and shaping into beautiful forms and fancies. Near them are the smaller rolls where bright strips of metal receive from steel dies impressions, in both *relievo* and *intaglio*, of birds, flowers, and such intricate interlacings as may be designed for borders. Passing through fire-proof iron doors—for the entire factory is built in fire-proof sections, like the water-tight compartments of a modern steamer—we stand in the presence of numerous powerful presses, slowly yet surely taking those initial steps that bring the metal sheets into form. Let us place a flat circular piece beneath one of them. A steel cylinder deliberately descends and holds firmly the outer edge, after which, inside the cylinder, a die steadily presses down the center of the piece into a round dish. The outer edge being securely held, and the pressure being sufficiently moderate to allow the particles of the metal to arrange themselves, the dish comes out smooth and perfect without

a wrinkle. Other presses are cutting, shaping, stamping, and doing much of the work formerly executed with the hammer. The drawing press was first adopted for these purposes in 1875. Few of the forms, however, are finished here. Most of them merely receive a preliminary impression before being sent to the "spinning room." The spinning of metal originated in Germany, and has been employed in manufacture for many years. The circular piece of metal, partially formed by the drawing press, is here placed against a wooden or iron mould attached to a lathe. As this rapidly revolves, smooth steel tools are brought to bear upon the metal, bending it over against the mould and gradually causing it to assume the proper shape. It is now in form, and, to the inexperienced eye, sufficiently smooth, but the orders are to spare no pains that shall insure perfection, and the dish is taken to the "turning room." "Turning" is another American idea, originally adopted, probably, on account of the imperfect spinning of the early workmen, and since continued by reason of the finer surface finish obtained. In the turning room the dish is again placed upon a mould or "chuck," and as the lathe revolves steel tools of different shapes remove all possible inequalities and bestow upon its surface a bright luster not unlike silver itself. Now come we to the soldering room, where our dish must receive a base, or perhaps feet, with handles, tips and a decorated border, already prepared in the moulding room, which we have passed. With these things firmly soldered to the dish in their proper positions, we are able to form some idea of what the dish is intended for. It has now to visit the finishing room, where it receives the last finishing touches before plating, after which the more precious metal, of either gold or silver, is deposited upon its surface. In the hall of the vats we may look down upon numerous thin yellowish solutions holding in suspension thousands of dollars worth of pure silver and gold. Here are the workmen at the scales accurately weighing articles, both plated and unplated, that the amount of silver deposited may be verified. Here also are the appliances, already described, for guaranteeing accuracy of weight while the articles are in the solution itself, and the rapid electric machines that furnish the mysterious power of disintegration and deposition. Our dish has received a potash bath, for its surface must be chemically clean and without the faintest suspicion of grease. Suspended from a small wire it is immersed in the solution, and there remains until the silver coating is sufficiently thick. Coming from the solution it is very beautiful—the deposited silver having a soft, velvety-white appearance not unlike newly fallen snow. In this room also is produced, by dipping in bi-sulphate of carbon, the beautiful oxidized work, while the natural colors of leaves, flowers, fruits, etc., in different alloys of gold, copper and other metals, are copied wondrously true to nature.

Our dish, after plating, is scoured with fine moist sand to cut down the inequalities that may exist, and passes into the hands of the burnisher. Burnishing formerly was exclusively hand work, and it is still for smaller pieces and for spoons, forks, knives, etc. It is accomplished by rubbing a polished steel tool moistened with soap water over the white surface of the silver, a brilliant luster being produced. The adoption of lathe burnishing has proved a great saving of labor, and is especially useful in treating the inner surfaces of such articles as cups, goblets, etc. The dish which is being made for us will obtain its mirror-like surface on the lathe, after which it will receive its decoration. Decorations are given, sometimes before plating, sometimes after, and sometimes during the process, depending entirely upon the style of decoration itself. A very interesting operation is the work of the hydraulic press. An expensive steel die, very carefully prepared, is fastened into the upper portion of the press. That surface of the dish designed for decoration is placed beneath, and an immense pressure forces the die against it. Being released the dish is found to have received a beautiful picture in silver, with sometimes birds, animals or fishes in raised or *repoussé* work, according to the design of the die. The variety of decoration that can be applied in this manner is limited only by the great

expense of cutting the dies. Formerly all decorations were effected by hand, the graver being the main tool, and, like the hammer, it is still indispensable for many ornamental chasings. The hydraulic press is but one method of applying decoration. The glowing tints and natural colors, from mingled alloys of gold, silver and copper, that are applied in the plating rooms; the matted leaves and flowers that develop under the hammer and the graver; the beautiful Celtic hammered work, and all the vast variety of ornamental designs, have each their separate treatment.

The dish now goes to the inspectors, and having passed their keen eyes as perfect, it is ready for sale. Now if we multiply this dish by five hundred exactly like it, and again multiply the result by five thousand articles different from it, but passing through the same or similar processes, some idea can be gained of the enormous production of this single factory.

Articles made of nickel silver must—with the exception of plating—necessarily pass through entirely different processes, not the least delicate of which is silver-soldering the different pieces together. Silver solder is a composition of silver and brass, and the articles require heating to a red heat in order to fuse it. So intense is the hot flame used in silver soldering the wires holding the pieces together are burned apart before the soldering is complete. Many of the other manipulations in forming, shaping, etc. nickel ware are exclusively "hand work," and of the same character as those used for solid silver.

The beautiful articles that thus find their way into the homes of the rich and poor alike are the embodied ideals of the artists of the designing rooms, and into this arcanum of dreams we may now enter. Here all is quiet save the muffled and indistinct hum of distant machinery that sounds like the subterranean forgings of Vulcan. Here are pictures and sketches upon the walls; books of art rare and beautiful; immense portfolios filled with art studies, and statues, busts, or *bas-reliefs* of mythological gods and goddesses by the score. Observe how carefully the artist at our left is making his picture. Every line must be exact, and neither more nor less curving. His drawing is for the die sinker, who must follow the design without deviation. Some day we may see it reproduced upon fruit baskets or salvers—veritable "apples of gold in pictures of silver." Next to him artistic fingers are moulding in wax a female figure, and bringing out with delicate touches here and there the smooth round muscles or the graceful folds of drapery. Still another is busy with a new design for a card receiver, and applying all those rules which are the life and soul of Art. The genius at work here must be, like a perennial spring, constantly sending forth that which is fresh and pure and true.

It is fitting, before closing this account of electro-plate, to consider its value from an artistic standpoint, and its influence upon public taste and culture. Means are not given to all men to procure in solid silver masterpieces of the highest art ideals. Wealth, although the primal source of refinement, does not always monopolize it, and in this country of free education the beautiful themes of a Benvenuto Cellini or Maso Finiguerra oftentimes awakens in the breast of an unsuccessful child of fortune as holy and enthusiastic an emotion as in his more prosperous neighbor. But the "thing of beauty" that would give to him perpetual enjoyment seems beyond his reach, and here begins the mission of the electro-plater. For the wealthy he provides a substitute, equal in everything except intrinsic value and associations, for the "family plate;" to the less fortunate he offers productions of the highest art at a price within their means. Certainly the artist has a wide field for distributing the creations of his genius. The fact that the manufacture of electro-plate is conducted for profit does not alter its elevating influence upon public taste, for while competition and the innate ambition of his co-laborers of the designing room impels the manufacturer towards higher planes of artistic merit, the consumer is also constantly developing higher appreciation of whatever is true and beautiful, constraining the artist to draw largely upon his resources to supply a demand created by

his own talents. Thus the manufacturer, paradoxical as it may seem, becomes both the pioneer and follower in art culture. Rules of design that apply to ornament and decoration must also control the production of articles for common use. This is especially true of the dinner table, with all its varied articles of furniture, wherein silver or electro-plate forms the principal embellishment. The artist, therefore, is impelled to combine with his own genius the purest works of every age and every clime. Assyrian, Egyptian, Grecian, Roman, Etruscan, Mediæval and Modern Art each gives to him its breath of inspiration, which, woven into enduring and imperishable metal, gratifies our æsthetic taste even while it ministers to our prosaic wants.

Concluded.

The Cylinder Escapement.

[BY HERMAN SIEVERT.]

Continued from Page 78.

WHILE correcting the escapement you may also investigate the drop of the wheel, as well as the shake of tooth and cylinder. Too large an outward drop is apt to be produced by too small a cylinder, and an undue inner one by too large a cylinder. If both the inner and outer drops are too large, the teeth will be found to be too short, in case that the incorrect shape of the lips do not unduly augment the drop. Since the shape of the lips assists in determining the size of the drop, it is better, in doubtful cases, to examine the shake, so as to ascertain whether the cylinder is of the correct size, and the teeth possess the necessary length. After you have gently secured the balance with a piece of paper, turn it toward the right as far as the drop of the tooth from the large lip. Then turn it back very little so that the tooth heel is within the cylinder, but that the lifting has not yet commenced, and in this position examine the shake of the tooth within the cylinder. Next turn the balance toward the left until the tooth falls upon the outer repose, and back a little to examine the shake of the cylinder between two teeth. If a little shake is present in both cases, and the wall of the cylinder be not too thick, the escapement is all right in this particular. If the tooth pinches within the cylinder, while it has sufficient shake outside, it is very probable that the cylinder is too thick. No good rate can be expected with such a one, and it is best to replace it at once. If there is too much shake outside, and only sufficient within, the cylinder is too small; and if the reverse is the case the cylinder will be too large. It is also possible that the teeth of the scape wheel are plenty long, and they are perhaps uneven in size. The same is the case if, by a sufficiently thin cylinder, there is too little shake both within and without, and in such a case the teeth are to be shortened a little. If the shake within the cylinder is insufficient, and full enough outside, the teeth must not be shortened, since the outer drop would simply be augmented thereby and the scape wheel ruined at the same time, because the defect is due to too small a cylinder. It has been established by practical experience that too small a cylinder never gives a rate remaining correct for any length of time. Therefore, before you attempt the grinding of the wheel teeth, carefully consider whether it would not be preferable to replace the incorrect cylinder by a new one than to also ruin the wheel. It is less detrimental for the regulating of the watch if the cylinder is a trifle too large. If, therefore, the tooth moves freely within the cylinder, but there is either no or unduly little shake outside, the shortening of the teeth would be admissible. The want of shake is most generally caused by a few extra long teeth, wherefore examine the whole wheel for this purpose, and mark the offending places with red. This is less troublesome and more secure than the equalizing by measuring with a turning arbor, customary in several workshops. The teeth are shortened by means of a ruby file. I have previously stated that the tooth heel decides the division of the

tooth, besides, the circumference of the wheel would be changed by grinding from the heel. Any correction of the length of the tooth, therefore, is to be undertaken from the point; this must not be made dull and broad, but the shape figured in table II, fig. 3, is to be retained. Everything to be removed is therefore to be ground obliquely from within. All scape wheels treated in such a manner, as well as those of new watches, are to be carefully burnished at the points with a polishing file. The file is to be sloped thereby, so that the points obtain an insensible rounding. A rough and scratching point increases the friction upon repose.

The balance of a cylinder watch must not make more than one revolution, since by a greater extension of the vibrations to the left the tooth would retain the lip, and by a revolution to the right the tooth pillar would strike upon the bottom of the notch. In order to limit its vibrations, the balance is provided with a banking pin, which strikes against the banking post on the bridge, and sometimes against the arbor of the fourth wheel. Its passing by must be prevented under all circumstances. The examination of the banking must also include the inspection whether the tooth point remains sufficiently far from the edge of the lip during its rotation to the left, and also upon the recoil of the wheel by a return motion. This latter must not occur if the watch is to preserve anything like a good rate. Even if the balance, while the watch is hanging or lying, does not vibrate so far, still, by incidental motions, when the latter is worn, the vibrations will continually be augmented or decreased. If the cylinder drives the wheel backward thereby at every moment, this in turn will drive the cylinder backward with noticeable acceleration, and such a watch will always gain when worn. But it must still less be possible that the tooth is pinched by the cut, so that not the banking pin but the tooth prevents the forward motion of the balance. In such a case a strong sudden twist of the watch will occasion the breaking of a tooth.

If a defect is present in the banking, examine first whether the banking pin stands correct. For this purpose fasten the balance by inserting a little paper under it, and turn it exactly as far as the drop of the wheel. In the upper cylinder bridge is a hole for the collet; exactly at this hole make a mark with red upon the balance. Do the same thing at the drop upon the other side. In the middle, between these two marks, must be located the dot serving as mark for mounting the spring. If, now, this point is situated near the hole of the collet, then banking pin and banking post must stand exactly opposite. The banking pin must be made very thin, and fastened very securely. A pin that may be drawn out with the tweezers would most assuredly loosen with time. If you have to drill a new hole for the pin make it as small as possible, but entirely through; the pin can more easily be fastened.

When the banking has been corrected in this manner, and it is found that the wheel recoils still, then the defect is due either to the shallowness of the cut or to the insufficient distance of the tooth point from the tooth pillar. The cut must be deep enough that only the one-fourth part of the cylinder has been left standing. When you look at a cylinder from one side so that both lips are on the same line with the eye, the end of the cut on the opposite side must be visible. A thin ruby file is used for grinding the cut deeper; better still is a grinding disc of thin tin plate, about 25 mm. in diameter, turned round and smooth upon its shaft. As grinding agent oilstone sediment, especially that from American stone, is very effective; the grinding disc is best set in motion by a fly wheel, and not too large a pulley. To grind a cut deeper hold the balance free in the left hand, paying special care that the side faces of the cut are not attacked by the grinding disc. An experienced workman will have no trouble, especially since the breaking of the cylinder need, with a sufficient amount of care, not be anticipated. Also the breadth of the cut may be enlarged in the same manner. One condition, however, is that the cylinder must be thoroughly cleaned afterward. The most trifling residue of oilstone dust would infallibly cause its destruction. It does not suffice to simply lay the

cylinder into benzine, but it must be washed in it with a stiff brush. Also the burr created by grinding is carefully to be removed.

If the grinding down to one-fourth of the cylinder circumference is still insufficient, owing to the shortness of the tooth points, a second pin must, as carefully as possible, be drilled into the bridge. A balance with two banking pins does not appear handsome.

There are several other more or less frequently occurring defects of the escapement which should not be passed by without mention. A scape wheel that does not run flat can be corrected upon an anvil of lead, copper or brass, with the aid of a small entirely flat punch. The straightening must be done near to the eye of the wheel, since it is less hard at this place. An obliquely standing cylinder, not hanging in the direction of the bridge, may be straightened by turning the latter, after the holes for the foot pins have been opened somewhat. Every filing and punching at these holes pertains to the domain of botch work, also the beating of burr, etc. The turning of the bridge, however, must be done in such a manner that it becomes thereby neither shaky nor need be put in place every time when the watch is put together. Of course the cylinder must not be in place during the turning. If the cylinder inclines toward the scape wheel stretch the lower bridge upon a smooth and straight anvil by means of a large punch like the small face of a hammer, which reaches across the entire bridge. If the cylinder is at the same time to be brought a little to the right, stretch the right side a little more, and vice versa. Although this stretching cannot easily be overdone, still it is better to examine it frequently. It is self-apparent that this straightening must occur only at one place and with a few strong blows. It is more serious when the cylinder hangs back; the only way to improve this defect nicely is by taking out the jewel hole and setting it anew. Less time-consuming is also here the stretching of the bridge, and when done very carefully, from below, and as near as possible to the regulator plate, not much can be seen of it.

The scraping of the balance and its arm on the scape wheel bridge, center wheel, curb pins and stud must, of course, be guarded against beyond a possibility of occurring. A banking pin striking against the fourth pinion or its arbor is frequently the cause of disturbances of rate. Less frequent, and, whenever occurring, very hard to be discovered, is the occasional gluing of the banking pin to the banking post, wherefore any substance provoking such gluing is carefully to be kept away.

Another cause occasioning the standing still of the watch, and equally hard to be discovered, is the presence of burr at the heel and small lip. If the balance should, for a moment, stop, due to an outward counter motion, this burr will prevent the restarting of the watch, and occasions the so-called "setting."

A worn cylinder, of course, can render no good services, and must be replaced. The repairing of the worn lips is not commendable, because the cylinder would generally become too wide, and beside this, the cause of the wearing is generally due to the cylinder, wherefore it would not be corrected. The several causes for this wearing are a cylinder either too soft or consisting of bad steel, a defective polish, rust, or grinding dust in the oil, want of oil, and a wheel with unduly soft lifting planes. It may perhaps be a cause of wonder that a soft wheel should wear a hard cylinder, still it is so. As soon as the soft lifting faces are attacked by the friction, fine steel particles mix with the oil, color it brown, and the grinding material is ready. As a matter of course, the same thing occurs with too soft a cylinder, whereby the polish of the lifting faces is destroyed in the same manner. It may occur, therefore, that a new cylinder is soon destroyed again, because the defect lies in the wheel. The repolishing of the lifting faces is done by means of a piece of soft main-spring. While the wheel runs in the turning lathe, the piece of the spring, provided with a little red and oil, is made to slide from one bevel to the other, always moving the spring a little to and fro, to prevent streaks. It is plain that the spring must not be too strong, and its position must about correspond to the inclination of the

lifting planes, so that these are treated throughout their whole length.

THE BALANCE SPRING,

Also called the hair or spiral spring, is a very important part of the watch, since upon its quality and disposition essentially depends the correct rate of the watch. The length of the hair spring must be proportionate to the extension of the vibrations, so that the spring is called upon to perform equally but not unduly strong throughout its entire length. Experience teaches that in a cylinder watch best results are obtained with a hair spring which, by a dimension equal to the radius of the balance, contains from 8 to 9 coils. The spring is to be well fastened at both ends, but must, throughout its entire length, not touch anywhere except between the curb pins, not even during its greatest vibrations. Danger of contact is to be anticipated by the inner coil with the riveting pin in the collet, the striking of the outer coil at the center wheel and stud, as well as the touching of the second coil with the curb pins. The hair spring must lie flat and free between bridge and balance arms, and center truly, so that the collet cannot crowd the coils closer together at one place. If these indispensable conditions are not complied with a good regulating is out of the question.

If a hair spring is too large, or, worse yet, drawn out of shape, ground or scratched thinner, pickled, etc., a good workman will not hesitate long in throwing it aside, because the mounting of a new one is easily effected. The thickness of the hair spring, of course, must stand in correct proportion to the weight, or, rather, to the regulating power of the balance; the stronger the hair spring the more rapid the vibrations. A larger balance requires a stronger spring than a smaller one of the same weight. When choosing a hair spring according to the weight of the balance, its size must be taken into account. The hair spring, for the purpose of weighing, is hooked with its inner end into the cut of the cylinder, while the other end is held with a pair of tweezers, so that both the cylinder and balance is suspended from it. If then the hair spring, of a suitable diameter and the requisite number of coils, forms a cone, of a height $1\frac{1}{2}$ times larger than its diameter, it will about be of correct strength. This statement, however, holds good only for a certain size of balance, suitable for a watch of 40 mm. diameter of plate. A spring chosen for a smaller watch must form a far greater cone.

From the inner end of the spring remove sufficient to permit full freedom to the collet, but not too much. Place the collet reversed upon a turning arbor, and file a nice pin, somewhat thinner than the hole for the spring in the collet. Now seize the turning arbor with the left hand, the small hole toward above, and insert from the side turned toward you the spring, and next the pin firmly into it, whereby you pay attention to the rectangular position of the spring plane to the turning arbor. If you have a fine pair of tongs for biting off the spring pin use it; otherwise place the collet of the turning arbor into the vise, and notch with a knife the protruding part close at the collet, so that it breaks when bent. Treat the other end in the same way, which you have until now held with tweezers. Next press in the pin a little, it might have become loosened by breaking. That the hair spring was pushed a little to one side by the knife cannot injure it by a little care. A protruding end of the hair spring is also to be broken off. Next bend the spring inside into the shape sketched in fig. 21, and in such a manner that it runs flat upon the turning arbor. The point at which the spring must be fastened in the stud is next to be found. For this purpose we count by a correctly going seconds watch the number of vibrations which the spring causes the balance to make, while the former is held with the tweezers so that the half-raised balance rests with the lower pivot upon the crystal of the watch lying upon the table. An ordinary cylinder watch makes 300 vibrations per minute, and in order to facilitate the work we only count the vibrations toward one side, therefore 150. If the seconds dial is well divided, and the hand exactly in the center, the comparison of one-half minute suffices. It is not well possible to pronounce in words even in thought so rap-

idly, wherefore count three times as far as 20 and once 15. This is to be repeated until the spring has been seized at the place where, in one-half minute, it retards about one-half second, because some consideration must be paid to the after-influence of the curb pins. At the point so found fasten the spring in the stud. The above process requires a little practice, but it saves much time and labor. It is commendable to flatten the pins serving for fastening somewhat to one side, else the part of the spring in the hole would be pressed hollow. This is of importance, if the spring should afterward be prolonged somewhat. The part pressed hollow would not work at all, since it has been made unelastic thereby.

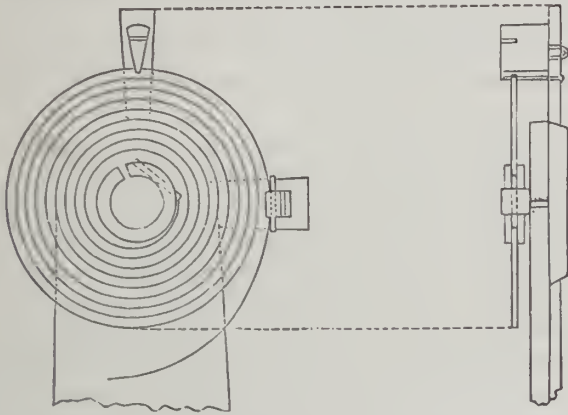

FIG. 21.

The regulator serves for shortening the spring, to correct a small difference in the rate of a watch. The space between the curb pins must not be more than three times the thickness of the spring, and be as near as possible at equal distance with the fastening of the spring from the jewel hole, which is at the same time to constitute the center of the spring. Now place the outer coil in such a manner that it always stands free in the middle of the curb pins, no matter in what direction the regulator is turned. Then bend the spring in such a manner that it lies free and well in the middle. The latter point may be observed well when the cylinder has been mounted in the watch; all coils must then have at every side the same distance from each other. The watch is to be regulated in such a manner that the regulator stands in the middle, or a little toward retard, since the cylinder frequently, after a continued wearing of the watch, shows an inclination for losing, in consequence of the thickening of the oil.

The following are special defects which prevent the exact regulating of the watch: Curb pins either too narrow or too wide; the former would pinch the spring, the latter would make the small vibrations slower than the large ones. With curb pins too wide the spring is, during a great part of the vibration, outside the shortening functions of the regulator, and this part will increase in proportion to the total vibration as the latter decreases, so that with small vibrations the spring does no longer touch the curb pins. A large retard will take place consequently by the increasing thickening of the oil. A position of the regulator too far out of the middle, if it has been placed much upon retard, has the same effect as unduly wide curb pins; with too great a motion of the regulator toward the other side its influence upon the spring becomes insecure, since the piece of spring between regulator and stud also exerts an influence. Loose curb pins can place the workman who has to regulate a watch, and does not notice this defect, on the ragged edge of despair. The pins have also to be kept very clean; the gluing of the spring occasions a loss of power and smaller vibrations, because it has to tear itself loose every time.

(To be Continued.)

lets numerous and easy. It is an old story that antique furniture, two or three hundred years old, dated from any desired landmark in history, is turned out every year in great abundance by those who are skilled in the business. Old clocks, old dressers, old bedsteads and old everything, even if made yesterday, have great value in the eyes of many persons satisfied with antiquity in appearance. Worm-eaten furniture is now one of the rages. This furniture is easily produced with the aid of bird shot, which is fired into it. Old houses torn down furnish worm-eaten timber of which this set of furniture used by Philip of Spain was made. France produces old Rouen and Sèvres ware by the carload. Limoges enamels are plenty. The new ones—nearly all are new—are buried in moist earth a month and then dated back 300 or 400 years, according to the wants of the customer. He can be suited as to age. The famous ware of Henry II.'s time is produced the year round. Treated with fluorhydric acid it becomes painfully old in a short time. A vase worth \$5 has been known to advance to \$1,500 with the aid of ten cents' worth of acid. In Berlin pottery used by the Romans—all the Cæsars—can be had by the crate. At home we make old coins, Queen Anne furniture and other kinds of furniture old as the hills. All these facts, sworn to by many newspapers, are now going the rounds for the exclusive benefit of those who might be robbed otherwise. An exchange says that the New York manufacturers of spurious wares send their products to the watering places, and there find ready buyers. Regency clocks are cast by the ton every day in Paris, but they are very scarce and bring fabulous prices.

The Great Stoneville Boom.

ARISTARCHIUS PLUMBAGO EXPLAINS HIS LONG SILENCE AND THE NEW ENTERPRISE HE IS ENGAGED IN.

BELIEVING that the readers of THE CIRCULAR take a kindly interest in my welfare and in the expansive enterprises that have their origin in my massive brain, and are the production of my ripe experience and intelligent cogitation, I again address you. My last effusion announced that I was preparing to establish a mammoth watch factory at Cincinnati, that center of musical culture and dressed hogs, whose enterprising and speculative citizens held out seductive inducements to me in the shape of a donation of large tracts of land in the suburbs, upon which I was to erect factory buildings, cottages for workmen, etc., and, in fact, build up an industrial suburb that should be tributary to the great city of pork. I had proposed to myself that by accepting this land donation and heralding forth my project for a watch factory, I should be able to dispose of the greater portion of the land at such a price as to enable me to put by in government bonds sufficient wealth to insure me that luxurious ease in my declining years that I have always sighed for. The prospect of establishing the watch making industry in Cincinnati was, of course, very faint, but I thought it well to keep up the illusion until I had effected the transfer of the land to my satisfaction. Consequently I announced my intentions in the most flowery language I could command, and entered earnestly upon the task of "booming" Cincinnati, and explaining the methods by which every person who bought shares in the new company was to be made a millionaire in a few months at the farthest. These pleasant fictions are excusable alike in poets and promoters of great enterprises. But, alas! I was doomed to again realize the instability of human hopes, and to drink deeply of the bitterness that lies in the cup of defeated ambition. On arriving in Cincinnati I hastened to present myself to those wealthy citizens who had promised to donate a large tract of land for the encouragement of my watchmaking enterprise, and in the exuberance of my spirits repeated to them the story of the immense profits to be realized by making watches on my improved and patented plans, regarding which I have heretofore given you full particulars. If I had any misgivings about their good faith in the

THERE ARE thousands of persons abroad in the land looking for avenues of escape for their money, and an army of handy workmen with wares to sell will do what they can to make such out-

matter they were allayed at this interview, when they again expressed their willingness to give me all the land I wanted. With full directions from them I proceeded next day, in a carriage, the hiring of which had materially reduced my exchequer, to feast my eyes upon the extensive domain of which I was the prospective owner. The driver conveyed me in a southerly direction, by devious and tortuous streets and back alleys, to the confines of the city, and some distance beyond. Here I alighted from my chariot, and found myself on the banks of the majestic Ohio river, then swollen by the contributions of tributary mountain streams till it had overflowed its confines, and had spread itself over much adjacent country. Exulting in the visions of prospective wealth and luxury that floated through my brain, I thus apostrophized this magnificent stream: "Boom on, thou majestic river; born among the mountain peaks and sweeping in majestic and boundless strides to rest and quiet in the bosom of the Atlantic, fertilizing the broad expanse of country on each side of you as you wind your way through the land, bearing the commerce of a nation proudly on your crest, and conferring countless blessings upon existing millions and upon unborn generations! Boom on! thou bright, beautiful and utilitarian river, and may your career be typical of the great enterprise upon which my untrammelled intellect is now incubating. May the career of my enterprise make as much stir in the land as you do; may it confer numerous blessings upon the community, but especially upon its creator, Aristarchius Plumbago. May it make these desert lands blossom with the flowers of industry, and may the watches we make—and sell—be as numerous as the pebbles upon your shores. May this grand scheme, too, flow on and boom from time to eternity, as you promise to do, knowing no limits, but bursting our banks whenever we get especially exhilarated, as you do. Boom on! Oh! muddy but majestic Ohio! watching over and bringing prosperity to the great enterprise I am about to plant beside you. Boom on! till you get tired, and if you require any more energy than you have, draw upon me at sight."

Having thus relieved my mind, I proceeded to search for the land that had been accurately described to me. I found some difficulty in locating it, but after interviewing a few of the natives I ascertained that the particular section I was in search of consisted of water lots, and that the disgusting river had buried them under ten feet of nasty, muddy water. I also learned that the abominable river had a habit of doing this twice a year, and that during the few weeks of drought, when the water lots were visible, they were covered by green slime, mud holes, bullrushes, frogs, toads, water snakes, and other unpleasant objects. To say that I was completely stunned by this discovery but faintly expresses the sudden revulsion of feeling that overcame me. From the pinnacle of bright expectancy I had been suddenly chucked into the mud of a disgustingly damp and muddy river. The wealthy capitalists of Cincinnati had misled a guileless man, and I, their helpless and impecunious victim, was crushed. It was cruel that these scheming men should have so deceived one who was ready to exchange his intellect and physical energy for a small but substantial tract of land, and to convert it into a hive of industry for his own glory and profit. Broken in spirit and shivering from the dampness of the slimy and watery river, I returned to the hotel, where an exacting landlord was expecting the money I had not in payment for board, and entering by a back door sought my room and my bed. Tortured in mind and body, I lapsed into an illness from which I am not yet fully recovered. In my checkered career I have met with many disappointments, but none equal to this. I have projected many great enterprises calculated to improve my condition and make my bank account solid, and while it has been my misfortune that none of these were successful, I have never been so completely broken up as on this occasion. Most galling of all was the thought that I, Aristarchius Plumbago, whose life had been devoted to speculative undertakings, had been taken in and done for by the bloated owners of money bags of the hogopolis of the country. As the soldier remarked, he did not mind being wounded, but to be wounded by the kick of a mule was soul crush-

ing. Thus ended the great Cincinnati watch company enterprise, and from this experience I have learned to look with suspicion upon those brilliant offers made by pushing cities and speculative property owners of large tracts of land for the fostering of manufacturing industries.

For several long, weary weeks I was confined to my room in the hotel in a state of illness and convalescence. I should have received what in vulgar parlance is called "the grand bounce," because of the depleted state of my finances, but for the fact that I had previously been chosen secretary of a state association whose correspondence I attended to. My charge of one dollar a letter was paid by the treasurer, for whom I had done some favors resulting in pecuniary gain to him, and on this sum and a few loans I obtained from members of the trade who were strangers to me, I contrived to satisfy the demands of an unappreciative landlord, and was permitted to remain.

During my illness I had many strange visions, some of which related to my past experiences, while others seemed to point the way to future enterprises. Most of these latter, singularly enough, identified me with manufacturing enterprises colossal in their conception and magnificent in their promises. In one of them, I seemed to see our old Chicago friend, who has won some notoriety as a promoter of Guilds, state associations, trade watch companies, etc., floating in the air like an ethereal cherubim; around his neck was a necklace composed of patent watches, while on his head he wore a crown of the same; he was singularly clothed in baggy pants and a swallowtail coat, and from the pockets of these bulged more watches. This airy form appeared to be hovering over a city that I recognized as Chicago, and as my eyes grew familiar with the vision, I beheld the word "Chicago" stamped upon every one of the watches it wore, while on a scroll the figure carried in its hand, there appeared the legend, "go thou and do likewise." The interpretation I placed upon this seraphic visitation was that our old friend had become identified with a scheme for making watches in Chicago, and advised me to enter upon a similar undertaking. Whether it was that I envied this enterprising spirit, that had been wandering so aimlessly and promiscuously for many years, for having his name coupled with a new enterprise, however wild and visionary, I know not, but I was haunted so persistently by this apparition that I finally determined to return to Chicago and see if I could not encounter like good fortune.

It was well for me that I came here, for now indeed do I feel that I am at last on the very crest of that tide which is to waft me to fame and fortune. On my arrival in this great and progressive city, I fell in with several adventurous spirits who have all the "speculation in their eye," that alas! poor Yorick lost, besides a liberal allowance of their own, and I have associated myself with them for the purpose, as they express it, of "booming" Stoneville. This is an aspiring little town in this state that is inflated with the idea that it is to be the great manufacturing center of the west, compared to which Lowell and other New England cities will be but as side shows. As some Chicago men own real estate there, this boom is to be worked up to enable them to sell off town lots at fabulous prices. Well, I am to have sole charge of the jewelry end of this boom, and the projects I have in view for the development of Stoneville as the metropolis of the jewelry manufacturing industry are worthy of this city of booms, and, I may say, worthy of me. I propose to locate in Stoneville several square acres of factories for the manufacture of all kinds of jewelry, plated ware, clocks, watches, bric-à-brac, and everything of a kindred nature that retail dealers in jewelry can carry to diversify their stocks, as so ably suggested by you in your May issue of THE CIRCULAR. Whatever will prove attractive and tend to induce the public to patronize the retail trade, that will we manufacture at Stoneville. According to a rough draft I have furnished the architects for the construction of these many acres of factories, they are all to be under one immense glass dome roof; the sides will be of plate glass, with iron columns for supports. By this

means we shall obtain an abundance of light, so that our employees can work to better advantage and more hours a day than is customary in other factories. All the machinery will be driven by electricity, for the generation of which I have ordered twenty-five dynamo machines of the greatest capacity. Our chief products will be jewelry, watches and clocks, and I shall here at last have an opportunity of presenting to the world my grand conception of a hydraulic-pneumatic-electrical-watch and clock movement combined, so arranged that it may be carried as a watch in a special case of my invention, or used in an elaborately ornamented mantel clock case, which is also the product of my brain. This will unquestionably be a great success, and will meet a long-felt popular want. We shall have extraordinary facilities for the manufacture of jewelry, for one of our number has been in the old junk business for many years, and has a large accumulation of scrap brass, second-hand solder, sheet iron, etc. We do not intend to use gold to any extent, as that commodity is becoming obsolete in the manufacture of plated jewelry, but, of course, will need a little now and then in our finest grades of goods. We have made arrangements with the International Credulity Junto of Retail Jewelers to adopt a stamp to be placed on all articles of jewelry that the individual members sell, and this stamp is the only certificate of quality that will be needed for our goods. When the public sees the Credulity stamp it will feel assured that the goods are of standard quality, and consequently it is immaterial as to what metal they are made of. The officers of this Junto are identified with our enterprise, and we have had resolutions passed by that body endorsing us to the fullest extent, and commending our goods to the public in preference to any others. I saw there was going to be a good thing in this Credulity Junto stamp business, and tried to have the contract made with me individually, but the officers dropped on the scheme and I had to let them in. Still it is a good thing even when divided up, for our company has the exclusive right to use this stamp. It is to be attractive in design, made in a variety of forms, and when impressed upon any kind of jewelry, does away with the necessity for any further ornamentation. A pair of Junto stamped bracelets will be something no lady can do without, while the varied forms in which the stamp can be made will enable us to make many very beautiful combinations in the way of ornamentation. Whatever goes out of our factories will bear the impress of the Credulity Junto stamp, and as all retail dealers in the Junto are pledged to sell only our goods, you can readily perceive that our market is made even before we are ready to avail ourselves of it. Of plated ware we shall manufacture every variety, each article being decorated with a profusion of Credulity stamps. As the Junto thus assumes the responsibility of certifying to the quality of all our products, no accountability will attach to us if our 14-k. goods do not assay even a "color" of gold. We shall endeavor to keep up the appearance of genuine goods, but our best hold is on the Credulity stamp. It will be to our interest to foster and encourage the International Junto, and to entice as many retail dealers into it as possible, so we have engaged the services of a garrulous, glib-tongued, retail jeweler and peripatetic peddler, named Oily Manison, to go about the country and organize state associations of retail dealers, making them all tributary to the International Credulity Junto, and bound by its rules and regulations and the contract with us. This contract, above all things, is to be maintained inviolable and perpetual. It is a big thing.

I have not time now to go into the details of my project for the upbuilding of Stoneville. Suffice it to say that in the course of a few months we shall have our boom in working order, and shall have entered upon the work of amassing colossal fortunes for its projectors. That is the chief end we have in view, the welfare of Stoneville being only an incident in the development of our enterprise. Since I first threw out a few hints regarding my intentions, real estate in Stoneville stiffened at once in prices, and holders of it are confident of a speedy rise in the market. Our company is to be called "The Stoneville Improvement Watch, Clock, Jewelry and

Bric-à-Brac Industrial Symposium, and Great Western Emporium of Mechanical Pursuits as Applied to the Fine Arts." I flatter myself that that is a captivating and seductive designation for a Jumbo enterprise like ours. All we need now is a little actual cash capital with which to pay my salary and necessary expenses. In order to provide this, I have organized the company with a capital of \$2,000,000, and now offer the shares for sale. The price is \$1,000 per share, but as an inducement for retail dealers to absorb them at once, and in the hopes of enlisting the active sympathy of every retail dealer in the land, I will now sell these shares for 50c. apiece, cash on delivery. I am desirous of having a number of them taken immediately at this figure, as there is danger that my boarding house will be closed against me and my linen remain unwashed unless I realize at once upon some of these shares. Knowing that you have always felt kindly towards me, I beg of you to use your influence to induce retail dealers to buy this stock and become sole proprietors of an enterprise whose success is assured. Meantime if you could send me five dollars in anticipation of sales of stock I should feel greatly obliged, and will repay you when I remit for the last five you sent me at Cincinnati. With profound respect, and with profuse thanks for the favors I expect of you, I am, very truly yours,

ARISTARCHIUS PLUMBAGO.

P. S.—I have had a few samples of plated ware made bearing the International Credulity Junto stamp, and think they will do. The plating is all I expected of it at the price, while the stamp provides a new and novel style of ornamentation. Possibly the public may not like it, but as dealers won't have any other kind to sell, what will the public do about it?

ARISTARCHIUS P.

Gold and Silver—their Elaboration.

(Continued from Page 125.)

THE QUICKENING fluid is a solution of protonitrate of mercury in water, and prepared by dissolving mercury in nitric acid, avoiding the use of heat thereby. Since the concentration of the quickening fluid largely influences its operation, it is advisable to always prepare it according to the same prescription.

A well tested recipe for preparing a strong quickening fluid is as follows: Mercury 100 parts, dissolved in nitric acid 110 parts, and diluted with water 25 parts.

A weaker one is prepared by dissolving 10 parts mercury in 25 parts nitric acid, and diluting with 1000 parts water.

The last specified prescription furnishes a quickening fluid which contains a considerable amount of free acid; should this have any effect upon the metal during the operation of quickening, it may be checked by adding another 200 to 500 parts water.

The operation of quickening may be performed by dipping a brass wire scratch brush into the fluid and vigorously rubbing the article with it, whereby this assumes the whiteness of tin from the separating mercury; else the quickening can simply be done in such a manner that the article is dipped into said fluid and left in it until the mercury layer is formed.

THE AMALGAMATING.

Before quickening is begun everything used in the operation of amalgamating must have been prepared, because the quickened article is at once to be treated to this process. The gold amalgam, the preparation of which was described previously, is kept on hand in a flat dish, the article laid upon a table, and the amalgam evenly poured over it and distributed with the scratch brush previously used in applying the quickening fluid.

After the article has in this manner been treated with a uniform layer of amalgam, it is thoroughly rinsed in water, to remove any still adhering quickening fluid, after which it is dried in heated sawdust, when it may be laid aside, for the purpose of treating another article in the same manner.

If a greater number of articles are to be treated, it is advisable that two workmen divide the labor; one of them quickens and amalgamates the dipped articles, while the second one attends to their evaporation.

THE EVAPORATION.

A brightly glowing charcoal fire is started in the draught furnace, according to the dimensions of the object, which is laid upon an iron grate at a certain height above the fire. The workman must frequently turn the article, to ensure its heating equally upon all sides.

Since the amalgam becomes fluid at a higher temperature, and would collect in the hollows of the article, it must repeatedly be withdrawn from the fire, and the amalgam divided with the scratch brush. When the object has finally been heated to the boiling point of the mercury, this evaporates quickly and passes off.

Evaporation is recognized by the surface assuming a mat yellow color, and the article has become so hot that a drop of water allowed to fall upon it is rapidly changed into steam. The evaporated pieces are laid aside to cool, and next submitted to the retouching.

THE RETOUCHING.

Retouching consists in repeating the operation of quickening and evaporating, and at times is repeated once, and with specially valuable articles even twice. The purpose of retouching is only to thicken the gold layer, hereby gilding the article more durably.

If the article still appears mat yellow after retouching, it is heated so strongly upon the charcoals that the last remnants of mercury, which are retained very tenaciously by the gold coating, are sure to evaporate.

The gilt article is next rubbed with a scratch brush dipped into a decoction of althea roots, until the gold commences to assume a luster, when it is delivered to the polishers, who burnish it wholly or in part by means of a bloodstone dipped in vinegar.

THE COLORING.

The treating of the gilt article with the coloring fluid is for the purpose of either causing it to assume a pure gold color, or a more reddish, whitish, or greenish one.

By coloring high gold it is necessary to dissolve the oxide layer which has formed upon the surface of the article during the operation of evaporating, whereby only the color of the pure gold stands forth. For this purpose a paste of angelica red, alum, table salt and vinegar is prepared, and applied by means of a brush upon the places to be colored.

The article is next heated sufficiently long above a charcoal fire so that the coating begins to turn black, and a drop of water left to fall upon it strongly hisses, a temperature of from 130° to 150°, after which the article is dipped in water containing a small amount of nitric acid, and, after drying, the colored places are burnished.

ANNEALING WAX.

The so-called annealing wax attacks the surface of the article in a manner similar to the coloring; red, yellow or green gold is produced according to the composition of this wax.

For red gold an annealing wax consisting of wax, copper salts and alum is prepared, and applied hot upon the places to be colored, after which the article is heated so strongly that the wax burns off, when it is dipped in water and rubbed with a scratch brush dipped in vinegar.

By the burning off of the annealing wax the copper is reduced from the copper salts contained in the annealing wax, by the decomposition of the organic substance; this copper combines on the surface with the gold, and forms a red-colored alloy; the substances contained in the annealing wax, apart from the copper salts, are actually useless for imparting a color, and simply serve for diluting the copper salt. We append a few prescriptions for the preparation of annealing-wax compositions, all of which are suitable to change the color of the fire gilding into a red color, by which the red gold-copper alloy is distinguished, and is of a very beautiful effect especially in statuettes.

PRESCRIPTIONS FOR PREPARING ANNEALING WAX.

I.

Yellow beeswax	100	Verdigris.....	6
Red bolus.....	9	Alum, calcined.....	2

II.

Yellow beeswax.....	100	Verdigris.....	12
Red chalk, pulverized.....	72	Alum, calcined.....	12
Copper ash.....	12		

III.

Yellow beeswax.....	100	Copper ash.....	18
Red chalk.....	54	Borax, calcined.....	6
Verdigris.....	54		

IV.

Yellow beeswax.....	100	Copper ash.....	20
Red chalk.....	50	Sulphate of zinc.....	30
Colcothar.....	2	Sulphate of iron.....	16
Verdigris.....	30	Borax.....	2

V.

Yellow beeswax.....	100	Sulphate of zinc.....	30
Red chalk.....	55	Sulphate of iron.....	20
Verdigris.....	55	Borax.....	10
Copper ash.....	30		

As will be seen by the preceding prescriptions, the single substances are mixed in very varying proportions, and another color is produced with every composition. We would advise, therefore, to keep the different compositions on hand, so as to make use of them for producing any desired color.

The preparing of the annealing wax requires a certain degree of care; indifferent results are always obtained if it is slighted when manufacturing it, and although the articles may obtain the desired color, still it will not be uniform but spotted, so that they have to be repeatedly burned off.

The substances employed must be pulverized to the highest possible degree, and their water driven off, before being stirred into the wax. This is the case especially with sulphates of iron and zinc, which are to be heated in porcelain dishes until all the water has been expelled; they are next pulverized in a hot state, and stored in well closed bottles.

The calcined alum is prepared by heating common alum in an iron vessel, which must be rather large, on account of the rising of the mass. The alum at first melts to a thin fluid, but soon changes into a firm, spongy mass, which is to be well heated and also pulverized.

For the purpose of manufacturing annealing wax the requisite quantity of wax is melted in a clean iron pan by not too great a heat; the previously weighed off substances are thrown in, well incorporated, and the pan is then removed from the fire and its contents stirred until they begin to solidify, after which it is rolled into thin rods upon a stone plate. Correctly manufactured annealing wax must be a homogeneous mass, in which no specks of any of the mixed in substances can be recognized.

According to recipes I, II and III the annealing wax colors the article red, that is, it produces a gold-copper alloy, and for a handsome gold yellow a wax containing much sulphate of zinc is to be employed (Nos. IV and V). In this case a copper-zinc-gold alloy, of a handsome yellow color, is formed upon the surface of the article.

THE GREEN COLOR.

No annealing wax is employed for producing green gold, but a substance of the following composition is used:

I.

Parts by weight.		Parts by weight.	
Saltpeter.....	12	Alum.....	2
Sulphate of iron.....	4	Water.....	20
Sulphate of zinc.....	2		

II.

Parts by weight.	II.	Parts by weight.	
Salt-peter.....	3	Sulphate of iron.....	3
Sal ammonia.....	12	Water.....	30
Verdigris.....	9		

The fluid is filtered after the solid bodies have been dissolved, and the articles are either entirely dipped in or the places to be colored green are painted with a brush dipped in the green color, and so strongly heated above a charcoal fire that they become black, after which, while still hot, they are dipped in vinegar, and cleaned by brushing.

Recipe I furnishes pure green color tones; No. II a color more inclining into red. If the red of the latter recipe is to be deepened, another one or two parts of sulphate of copper is added to the quantity.

MATTING.

This operation effects to make the entire surface of the article either a lusterless mat or only in parts, and it is one of those operations in fire gilding calling for the greatest attention of the workman, otherwise the entire gold coating of the article can so utterly be ruined as to render the latter useless.

Articles which are to be mat in some and lustrous in other parts must, before matting, be provided with a covering at those places intended to be lustrous, whereby it is protected against the effect of the chemicals thereafter to be used. A substance of the following composition is employed for this covering: Washed chalk, 100 parts; sugar, 10 parts; mucilage, 10 parts.

These substances are, in a pulverized condition, intimately mixed in a dish, and, with an addition of water, ground until reduced into a thin paste, and with a brush or plume applied at the places to be left lustrous; when dry it forms a pretty adhesive coating.

After the places of the article to be left lustrous have been treated in this manner, the coating is allowed to dry.

The matting powder is prepared in the following manner: Salt-peter, 80 parts; cooking salt, 50; crystalized alum, 70; are coarsely pulverized, mixed, and heated upon a charcoal fire in a porcelain dish; the alum fuses rapidly in its water of crystalization, and the mass is continually stirred with a thick glass rod as long as it emits steam, attention being paid not to heat stronger than to about the fusing point of lead. If the heat was raised beyond this degree the different substances would exert that chemical influence upon each other which they are designed to effect upon the article to be matted, and would, therefore, be without subsequent influence. As soon as it is noticed that brown vapors or chlorine odor begin to evolve from the mass the vessel is at once withdrawn from the fire and cooled rapidly.

The heating is to be continued until the entire mass is of a thin homogeneous paste, the dish is then removed from the fire, the hardened mass pulverized finely, and preserved in a glass bottle until used.

In order to perform matting correctly heating must not be done above free charcoal fire, since the article is hereby not heated uniformly, but a matting pan or pot is used for the purpose. This consists of a cast iron pot of adequate size, which, standing upon a tripod, is placed into a draught furnace, and heated by coals laid around it.

Work begins with holding the article coated in above-said manner with tongs into the hot matting pot until the coating assumes a blackish color, and subjected to such a degree of heat that the matting powder thrown upon the article fuses quietly, and, after it has spread upon the surface, quickly solidifies again. The workman must hit the right degree of heat; if the article was not heated sufficiently the matting powder will drop off from the places at which it did not adhere by fusing; if too hot the effect of the powder may become too strong, and the gold coating is eaten through.

After the first layer of matting powder has been applied the article is again heated sufficiently so that the former is reduced to fusing;

the article is then again taken out of the pot and more powder applied, which, with the assistance of a silk ball, is to be spread as uniformly as possible upon the surface. If strongly gilt articles are under manipulation, such as were retouched once or twice, the matting powder may also be applied more thickly, from three to four times, without fearing that the gold coating suffers thereby.

After each application of the matting powder and heating it to melting, the operator must wait until the pure gold color is developed under the fused mass, and reddish-brown vapors are evolved from the latter; the article is then withdrawn from the pot, more powder applied, and returned into the pot.

The powder contains alum; this evolves sulphuric acid in strong heat, which operates upon the salt-peter and cooking salt in such a manner that nitric acid and hydrochloric acid are liberated. The nitric and muriatic acids, however, operate upon each other like nitro muriatic acid (*aqua regia*), red fumes of hyponitric acid are evolved, and free chlorine is dissolved. The chlorine attacks the gold, which hereby becomes void of luster; if the layer of gold was too thin, or if too much matting powder was employed, it may happen that the former is eaten through, whereby the article is ruined; matting finished, the object is laid in water, in which both coatings dissolve, after which the article is cleansed with the scratch brush, and the not matted places are burnished.

Bronze articles were formerly fire-silvered by the use of silver amalgam, a work which is no longer executed, since there are a great variety of processes by which bronze or other metals may be embellished with a handsome silver coating. As was already said in the introductory, fire gilding is but little employed at present, since especially the galvano-electric process offers a much more commodious method for effecting very handsome coatings.

XXIII.

GILDING AND SILVERING BY OTHER METHODS.

If we except the processes of galvanic gilding and silvering, and the fire gilding, we may reduce the various other methods by which gold and silver coatings may be produced into several groups, distinguishing:

1. By boiling, gold and silver fluid, hot gilding.
2. By dipping, cold gilding or silvering.
3. By rubbing.

The first-named process is especially well suited for gilding silver and bronze articles of an inferior value, and when it is combined with the so-called contact method, very handsome and durable gilding may be produced. Cold gilding is used only for small articles, such as pins, metallic pens, etc., and is little durable, more so, however, than the gi'ding produced by merely rubbing. The same degree of deterioration is also true for silvering.

A.—GILDING.

GILDING BY BOILING.

The majority of the gold combinations are so loosely united that they may very easily be decomposed; it suffices to dip a base metal into a gold solution to effect its decomposition. The gold, however, is in this case so rapidly precipitated that it does not intimately combine with the metal, but adheres so loosely that it may be wiped off with the finger. The gold must therefore be employed in form of difficultly decomposable combinations. If a copper, bronze or silver article is immersed in a fluid, and touched with a piece of zinc, the metals will form a galvanic element with each other, and an electric current is generated. Since electricity promotes the decomposition of combinations, the gold will precipitate upon the article in form of a cohering layer, in a manner similar as if thrown down by the galvanic process. This process, for sake of distinguishing it from the galvanic, is called the contact gilding, since it is produced by contact of two unequal metals. Small articles, which, of course, must have first been thoroughly cleansed by pickling, may be gilt almost

as durably as by the galvanic way, if they are united with a piece of zinc, for instance, wrapping them in zinc wire, and immersing them in an almost boiling solution of cyanide of gold and potassium, of the same composition as used for galvanic gilding.

ELKINGTON'S BOILING PROCESS.

156 grams gold are dissolved in a mixture of 656 nitric and 344 muriatic acid, evaporated to dryness in the water bath, the chloride of gold is dissolved in water, diluted with 20 liters water, 10 kg. carbonate of potash are added, and the fluid is boiled for two hours.

(To be continued.)

A Fine Varnish for Coating Optical Instruments.

SHELLAC, in one of its many shapes, forms in this case, as in most others, the foundation upon which varnish is built, and, indeed, we may say at the outset that a plain solution of shellac makes one most excellent in quality. Shellac, under its various names indicative of its color, is really only another form of the so-called "seed lac," and also of stick lac, some recipes giving most absurd instructions as to the proportion of the various forms of resin to be used. Stick lac is simply the twig incrustated by the lac insect with the peculiar substance it produces. Seed lac is the incrustation removed, in which state it presents the appearance of small seed; and shellac is the purified seed lac, melted, strained, and placed on slabs to harden, from which the resin is chipped or shelled off as "shel-lac."

Shellac is found in commerce of an infinite variety of shades of brown, from the pale "orange," as it is termed, to the deep garnet or ruby color, which is useless for our present purpose. Such shel-lac dissolved in spirit would give a solution that could not be decolorized in any practical manner—at any rate by the working optician. For our purpose, very finest "pale orange" shellac procurable should be purchased, and when varnish is to be made in quantity, the samples must be first obtained, so as to enable the stock to be purchased where the palest sample came from. Those who have not before paid any attention to the matter will be surprised to discover how varied in color even high-priced shellac will be found. Another consideration, which will scarcely need to be pointed out in the selection of shellac, is to see that the pieces are as clean looking as possible. In this respect also great differences will be found.

A solution of such shellac in methylated spirit forms the basis of our varnish, and a simple varnish so made will answer for all rough work; but where delicate results are wanted, it must be paler in color, and for this purpose we use "bleached shellac." Bleached shellac dissolved in spirits also makes an excellent varnish, but it is not nearly so hard and tenacious as that from the orange shellac. A good strong coating of it is really scratched by the finger nail—an occurrence which may be accompanied by consequences of a disagreeable nature that such varnish cannot be recommended. White shellac is made by dissolving ordinary shellac in caustic alkali, and then treating the solution with chlorine, which at one and the same time decolorizes and precipitates it. This process, though it produces a pale resin of great value for many economical purposes, causes the resin to lose many of those properties that specially fit orange lac for use in photographic and fine varnish. One of the peculiarities of white lac varnish is the frequency with which it dries into a multitude of fine ridges, which no rocking of the surface to and fro during draining and drying will prevent. But for paleness of color in the coating obtained from it, nothing can be better; and in a mixture of the two resins—that is, the bleached and the unbleached—the objectionable qualities of either seem either covered or greatly reduced. This mixture in suitable proportions constitutes the chief part of the varnish we recommend.

Experimenters with "bleached," or, as it is often called, "white lac," must know that unless it be properly stored, it practically loses

its solubility in spirits of wine; and we know of many cases of failure in varnish-making caused through the purchaser being supplied with a sample that had become insoluble. Of course, this would not be likely to occur in a place where the lac was in great demand; but many of our readers live in places rare chemicals are most difficult to get, and when obtainable are not always in good condition. However, in the case of white lac, where the experimenter is ignorant of the appearance it should present, he can easily test a small quantity, if he has any doubt in the matter. It should be crushed or pounded into small pieces before adding to the spirit, as even in the best samples a large proportion entirely insoluble always exists, and a clear solution must not be expected. Its solubility, or the reverse, is soon discovered by noticing whether the small particles begin to disintegrate, as it were, or retain their sharp outlines.

A good indication of insolubility is the outer layer of the round pieces or sticks turning semi-transparent. The plan usually adopted to prevent this change taking place is to keep the bleached lac in the dark and covered with water, when, if it remains so covered, it will retain its solubility in spirit for a long time.

The third and last ingredient in this varnish is "gum sandarac." It is well known by varnish makers that, when gums and resins are mixed and "blended," the character of this solution or varnish is not by any means of necessity an average of the characters of the gums taken separately, and such is the case with sandarac. This gum, taken by itself, gives a varnish that is quite useless, from its brittleness, but when added to a shellac varnish it confers a portion of its own quality of brightness of surface, which it possesses in a high degree, but does not, in moderate quantity, tend to make it "rotten."

The formula for a varnish devised on a principle above stated is as follows:

Palest orange shellac.....	ounces,	2 $\frac{3}{4}$
Bleached lac.....	"	5 $\frac{1}{2}$
Gum sandarac.....	"	$\frac{1}{2}$
Methylated spirit.....	quart,	1

Bruise the bleached lac till reduced to small pieces. Powder the sandarac, and then add the whole to the spirit, putting in a few small pieces of glass to prevent the shellac caking at the bottom of the jar; stir or well shake the whole from time to time, until it is evident that solution is complete. All that is then necessary is to set aside to settle, pour off the clear, supernatant fluid, and filter the rest. It is best to allow a month or two for settling, for the insoluble part occupies so large a space that much waste through evaporation, etc. is caused, if an unnecessarily large quantity be passed through the filter.

Having used the above as well for coating photographs as for the brass work of optical instruments, we feel confident that we can highly recommend the formula.

Correct Local Time and How to Obtain it.

A CORRECTION should be made in April number of this journal. In the thirteenth line below the cut, for "opening," read "spring." The weight shown at *W*, fig. 3, April number, should terminate in a wire or rod working through two holes so as to allow the weight to rise and fall freely, and still prevent the weight *W* from establishing a swinging or pendulum motion of its own. The wire should descend from the bottom of the weight and pass through an eye immediately above the lever *k*. This will be better understood by consulting fig. 2, in this cut, where *W* represents the weight and *a* and *b* two eyes through which this steadying wire *ee* passes. At fig. 1 is shown the compensating device in a skeleton frame composed of two rings shown at *ff*, fig. 3; these two rings are united in parallel planes by the rods *gg* (four in number), and each ring has four spokes or arms as shown at *hh*; these arms unite at two

axles shown at *dd*. The compensating device is placed inside this skeleton drum so as to be as nearly poised on the pivots *dd* as possible. After the parts are all made and arranged as described here and in the April number, the drum should be put in the position shown in fig. 1. The weight *W* should now be fastened in the position it hangs at the time by a set screw shown at *c*, fig. 2, and the lever *k* (April number) fixed to the position it is in at the instant, by a screw passing through the joint on which it works. Or in other words, when the compensating parts are all in position and placed in the ring as described above, all the movable parts are rendered rigid by the set screws; now the ring and all its parts are poised as a whole on the pivots *dd*, and the entire arrangement of rings and compensation device is placed in the pendulum as shown at fig. 4, *N* being a side view of fig. 4. If now the set screws used to fasten

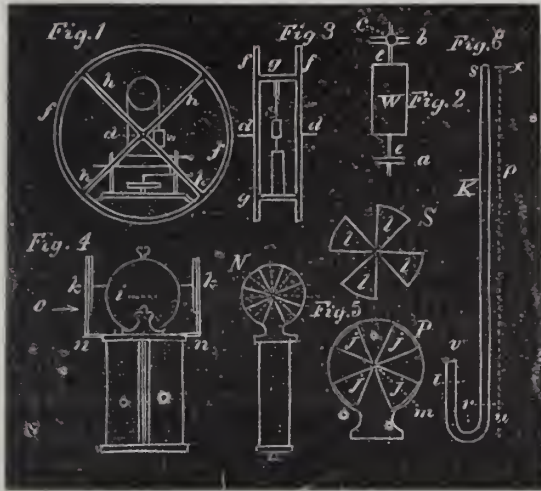

the weight *W* and the lever *k*, were unloosed, the whole device would only amount to so much weight applied at the point indicated by the dotted line *i*, fig. 4. It should be understood that all the parts would suffer no change by the relaxation of the set screws, except a change in the density of the atmosphere. But in adjusting such a pendulum it would be advisable to leave the set screws unloosed until all the other adjustments, such as rate, heat and cold, were perfected, and there was no disturbing influence except barometrical; then, if the set screws are released, our compensation for a denser atmosphere commences to operate. In actual practice the skeleton rings and pivots can be dispensed with, but the device was selected more to convey the idea that the arrangement should be added to the pendulum ball in such a manner as to in no way disturb it; except as so much weight, and the device rendered passive by the set screws, until all other compensations were complete. Another system of compensation can be used which may suit some persons better, and this is very similar to the one just described, except vanes are used to correct the barometric disturbance. The only change which need be made in the device shown in the April number, is to suppose that the elevation shown in fig. 3, April number, is at right angles to the arc of vibration of the pendulum, and that the weight *W* is dispensed with, and that attached to the axis of the wheel on which the fusee chain *j* winds, are two vanes shown at *k k*, fig. 4, of the present cuts. These vanes consist of two pieces of thin metal shaped as shown at *S*, fig. 5. *A n n*, fig. 4, are two rods extending from the frame of the mercury jar holder to two discs; one of these discs, as seen in the direction of the arrow *o*, is shown at *P*, fig. 5. These discs are cut in openings to correspond to the vanes, as shown at *j j j j*. The principle on which these vanes act is, that the vanes placed in close proximity to the perforated discs, can be made to offer more or less resistance to the atmosphere, as the wings *l l l l*, of the vanes close the apertures *j j j j*, the vanes being so arranged that at about the average density the edge of the pieces *l* stands at the dotted line *m*, fig. 5. It is to be understood that as the air increases in density the vanes retreat behind the sectors of the discs, consequently the device offers less resistance to the motion of the pendulum, and *vice versa*. At the average density the vanes should close

about one-half the apparatus. As the resistance of the air in this case is a constant force, increasing or diminishing in regular ratio, this device can be made to compensate almost perfectly. The writer wishes to call attention to the fact that only to clocks or time keeping devices of exceptional accuracy need any such compensation be applied; as it is evident to all who give the subject attentive thought, that barometric fluctuations are of brief duration, the *average* height of the mercury being about the same throughout the year. The plan just described can in no way interfere with the performance of the clock, if all the parts are poised, except in its action in regard to more or less atmospheric resistance, and this is of such simple calculation as to hardly need notice; if your barometer rises (increases in density) from 29 to 30 inches, you diminish the resisting surface in the ratio of 30 to 29, and it is compensated, *i. e.*, the vanes retreat behind the disc in this proportion. Of course, the size of the discs and vanes must be proportionate to the surface resistance of the mercury jars and frame. The important obstacles, as have been suggested previously, are heat and cold, and jar of wind and traffic, and it is only *after these* are fully counteracted that we need bother ourselves about barometric compensations. I called attention to one feature of pendulum clocks early in these articles, and this is: A pendulum beating seconds being of considerable length (39.0958 inches at Washington), the different parts of the rod is subjected to different degrees of expansion; that is to say, the upper part of the pendulum rod is in a temperature of 70 degrees, while the mercury jar which does the compensating is only exposed to a temperature of 60. A device to correct this defect in compensating a mercurial ball (the gridiron rod being to a certain extent exempt from this defect) is offered by the writer, with the caution that he has not put the plan to the crucial test of actual trial, still, it looks every way feasible. The idea is to run a glass (or other) tube up alongside of the pendulum rod, this tube being filled with alcohol and mercury. The principle on which this device is to act is shown in fig. 6, *K* representing a glass tube, the dotted line *p* the pendulum rod, and *x* the point of suspension. The tube *K* is filled with alcohol from the point *r* to the top and from *r* to *t*, with quicksilver. It will be seen that as the tube *K* is filled with alcohol from *s* to *r*, any rise in the temperature of the air surrounding the tube *K* will cause the mercury in the tube to rise at the point *t*. It will be also seen that as the alcohol column rises through the entire extent of the pendulum rod in close proximity, it must be exposed to the same conditions of temperature, and consequently, if properly arranged and adjusted, must almost perfectly correct this (heat and cold) disturbance. A number of advantages suggest themselves in considering this plan, among them air; we can use lead (or other metal) for the pendulum ball, as an ounce or two of mercury would be quite sufficient, and by mixing water in different proportions with the alcohol, we can almost perfectly adjust our compensation, as will be seen on comparing the expansion of the water and alcohol by heat. Alcohol expanding almost three times as much as water; consequently, by mixing the two substances, we can procure an effect just to our wants. The mechanical arrangement can be readily effected.

Advice to Watchmakers' Apprentices.

BY A MAN WHO HAS SPENT TWENTY YEARS AT THE BENCH

IN MY LAST communication I gave the general outline of a kicking press, the general principles of which is on the fly or ball press plan, but with two important advantages, the first of which is, the dies do not pass one another to a damaging extent, and the second is the knee joint principle husband the force for the point where the greatest power is necessary. The cuts are slightly changed in this number, owing to the suggestions of a friend who saw the drawings. The changes made are to allow of a wider die; the press shown will enable the owner to punch out pieces three and one-half

inches long, and a proportionate increase in width and thickness (of the press) will enable one, by the use of a heavier pendulum weight, to punch out pieces from No. 24 brass 5 inches long by $\frac{1}{4}$ wide. The press shown here is intended to use one or both feet—but it is very seldom, however, one is called on in anything in the jeweler's line to use a power above what one foot and leg will yield. The scale on which the cuts are made is $\frac{1}{8}$ of the real size. These cuts in conjunction with those in the last number of THE CIRCULAR will serve to give the idea of the action of the press, and the present cuts will give by measurement the sizes. But a few sizes in figures will not come amiss. *A*, *B* and *C* are 15 inches long and 5 wide; the sizes of subordinate parts are to be got from the cut. Such a press would weigh complete about 185 pounds. The bench *K*, on which it is mounted, should be at least two inches thick, and well supported to keep everything solid. This press is best used sitting

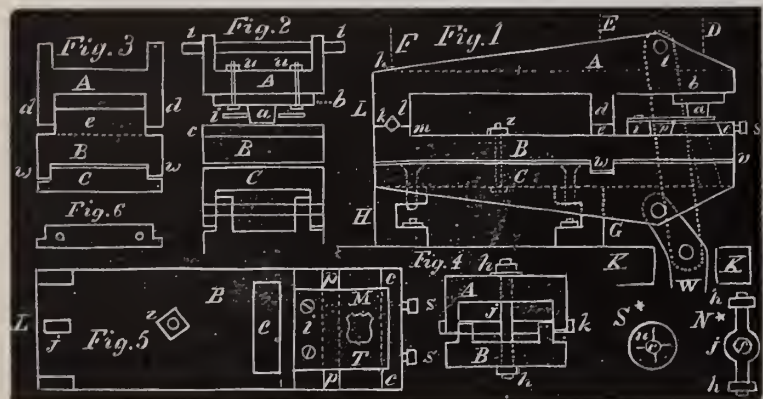

down, and by having a rod or bar to grasp with the hands so as to give greater scope and power to the motion of the legs; a piece as large as mentioned above can be cut out, but the number of pieces so cut out will be fewer. It is well here to speak of some parts shown in present cuts, which were omitted in last number. At fig. 1, which is a side elevation of the press, are shown dotted lines *D*, *E*, *F*; these lines indicate vertical sections at right angles to the plane of this cut (fig. 1), and these sections are shown in their order at figs. 2, 3 and 4; that is, section *D* at fig. 2, section *E* at fig. 3, section *F* at fig. 4. At figs. 1 and 3 are shown, at *d e*, two pieces which are cast fast to *A* and *B*; the action and position are best shown in fig. 3. The use and object of these pieces are to prevent lateral motion of the jaws *A B*. It will be seen that the joint at *L* prevents any forward or backward motion, while the pieces *d e*, prevent any in the opposite direction. These pieces (*d* and *e*) can be cast on very near to size, so a trifle of filing and fitting will adapt them to each other. At *i*, fig. 1, is shown a piece for taking off or removing the male die from the sheet metal. It is well known that the male die as it is forced through the sheet metal sticks, or stays in the sheet from which the blanks are punched; if a plate of strong sheet metal is screwed to the projection cast fast to *B* and shown at *i*, the male die shown at *a* will, as it rises, be drawn from the plate being punched. It is of course understood that the male die works through an opening in the plate attached to *i*; this opening is large enough to allow the die to pass freely through it, but still it conforms to the outline of the die close enough to prevent any bending of the sheet. A plan of this piece for withdrawing the punch or male die is also shown at *T*, fig. 5, by the dotted line extending forward from *i*. At *N** is shown a bolt with a hole at *j*, and two nuts at *h h*; the use of this bolt is to clamp the pieces *A B* together at *L*. The joint pin at *L* is also shown in the section at fig. 4, as well as the bolt shown at *N**, and the position of the nuts shown at *h h*; the joint pin *k* passes through the eye on loop *j*, diagram *N**. This bolt, with the loop on eye *j*, passes through both *A* and *B*, and keeps the bolt *k*, fig. 4 securely in the notches in *l* and *m*. To secure a certain amount of elasticity to this joint (*L*), at *S** is shown an elastic washer two inches in diameter and $\frac{1}{8}$ thick, made of steel; the hole *r* is $\frac{3}{8}$ of an inch, and slots as at *n* run radially out, and are $\frac{1}{2}$ inch long. These partially cut-out sectors are bent upward so as to

make an elastic washer under one of the nuts *h*, diagram *N**. This washer forms an elastic joint at *L*, and keeps the pin *k* constantly in the notches in the pieces *l m*. The pieces *G H* are for bolting the press to the bench. The upper face of the female die should be on a level with the center of the rod or joint at *L*. The lower die is held in position by two screws *s s*, fig. 5, passing through the piece *c*; this piece can be either cast fast to *B*, or secured with strong screws and steady pins. The lower die is shown at *M*, fig. 5, and on the opposite side of the die *M* to the piece *c*, is a similar one shown at *p*, and between these go the dies; the pieces are slightly undercut, as shown at fig. 1. Between the die *M* and the piece *p*, strips of metal can be interposed so as to bring the die forward into position, and the set screws *s s* can hold the die in place. The lower die should be fastened first, then the upper die by the bolts *u u*, fig. 2. Uniting *B* and *C* is a bolt shown at *z*, fig. 1, and at *w w*, fig. 3, are two pieces (a side view is also given at *w*, fig. 1); these steady and keep *B C* in position. We will suppose we have a die to put in the press; we remove the bolt *t*, figs. 1 and 2, and the nut *h* at the joint *L*; this will enable us to remove the top jaw *A*. The lower die *M* is inserted between the pieces *c* and *p*, and secured by the set screws *s s*. The plate for removing the male die from the piece punched is screwed to the block *i*, so the upper die will just enter the lower die and lie free in the stripping piece *T*. If the dies are properly made and fitted, the upper die will enter snugly (fitting exactly, so as to cut wet paper), say for the $\frac{1}{16}$ of an inch. The male die is left in this position and the top jaw *A* is restored to place and the nut *h* put on to secure the joint *L*, seeing the elastic washer *S** is doing its duty, the bolt *t* restored. The pendulum lever *W* is swung forward so as to bring the jaw *A* down firm on the die plate *l* of the upper die; the screws *u u*, fig. 2, are set up to hold the upper die in place. At the front shown at *v*, fig. 1, when the dies are inserted, should be placed a slip of sheet metal a little thicker than it is intended should be placed there when the press is working; this will enable you to bring the jaw *A* down firm on the upper die, and hold it while the screws *u u* are tightened, as soon as the upper die is in place. This last-mentioned slip of metal at *v* should be removed. The bolt at *z*, fig. 1, binds the two parts *B C*, forming the lower jaw together, and should be loosened to admit changes of slips at *v*. These slips should be about five inches long by $\frac{3}{4}$ of an inch wide and shaped as shown at fig. 6, the notches at the ends going against guide pins inserted in one of the pieces (say at *C*); this is to keep these slips in place. These slips should be cut from sheet iron of different thicknesses, so that by changing them you can just force the die through the metal to be cut. To any person who has used a Parker press this will be very simple—but to others we will say, suppose we wish to interpose between *B* and *C* a slip a trifle more than $\frac{1}{16}$ of an inch thick, and we have no one piece of the exact thickness, but we can combine four pieces which will exactly do the work—we may have to take out one piece which is a little too thick and change for one a trifle thinner. There may have to be several changes made before we hit on the right combination of slips which will cause the die to effectually crush through the metal to be punched, and still not cause the dies to pass far enough to cut one another. The holes in the ends are to secure them in place when the right combination is hit. When all the parts work correctly the screw *z* is set firm.

A POUND of pure gold, in a crude condition, costs about \$300; one pound of iron, however, is barely worth a few cents; but when the finest of Geneva watch springs are manufactured from the pound of iron it costs \$5,000, consequently a sum to which a pound of gold, even if elaborated to the highest skill of the art, can never hope to attain. This also holds good with many other apparently valueless substances, for instance, a pound of cotton worked into Honiton lace. Work, therefore, creates the highest value.

Proceedings of the Horological Club.

A DISTINGUISHED BODY OF WATCH AND CLOCK MAKERS.

One hundred and eighth Discussion.—Communicated by the Secretary.

[NOTICE.—Correspondents should write all letters intended for the Club separate from any other business matters, and headed "Secretary of the Horological Club." Direct the envelope to D. H. Hopkinson, Esq. Write only on one side of the paper, state the points briefly, mail as early as possible, as it must be received here not later than the eighth day of the month, in order to be discussed and reported in the CIRCULAR for the next month.

• GOLD RINGS BLACKING THE FINGERS.

Secretary of Horological Club:

Can you or any of your members tell me the reason and the remedy for an 18-karat plain ring blacking the finger, not only the wearing finger, but both fingers on each side? I have had a good deal of trouble with my customers in regard to it, and am sometimes unable to satisfy them that the article is what I represent it. I have inquired of many old jewelers, but have not been able to find anyone that can solve the trouble.

JEWELER.

Mr. Rolliver said that this question had been frequently answered in our Proceedings. The cause is that the perspiration of the fingers acts upon the alloy of the ring and produces the stain. The perspiration of some persons is so decidedly acid that it will rust steel or iron at once, that of others is alkaline. Sometimes the sweat is very salt, *i. e.*, contains chloride of sodium, and a great variety of other salts and substances can be found in the perspiration of different persons. Sulphur, mercury and other substances, when taken internally to any great extent, will be plentifully exuded through the sudatory glands; and, of course, when used externally, their presence is still more obvious. Any of the substances named may cause the stain complained of. But persons who do not perspire, and whose skins are always dry, should not be troubled in that way, unless sulphur or mercury are present in the blood to such an extent as to exhale from the skin. If acid or other substances having an affinity for copper are worked in with the hands, they may, of course, cause stains irrespective of their presence in the system. Eighteen-karat gold should, however, resist all ordinary perspiration and liquids. And if "Jeweler" should find that these stains occur in cases where the before-mentioned causes are all absent, it might be well to have the gold-tested by a reliable assayer, in order to be certain that the difficulty could not be in the gold itself.

A STRIKING WATCH SIGN.

Secretary of Horological Club:

I want some advice in regard to the construction of a clock, or a large watch. I want to make a striking sign, and this is the way I propose to do it. I would have the rim about the size of an ordinary watchmaker's sign, cast of bell metal, and the shape of a watch—case, rim, stem and all. Now, I would cut this rim on one side near the stem. The movement, hands, faces and glass will have to be fastened by a strong bolt passing through the stem, boxed, and so arranged as to not touch the rim, and the whole suspended by a good pendant bow. The hammer is to strike out and hit the rim. What I wish to know is, can a movement be put in that will make the hammer hit sufficiently hard, and if so, would the rim thus constructed amount to anything as a bell? Of course, it would be on a small scale, but that is all I expect of it—sufficiently successful, however, to prove an attraction.

S.

Mr. Uhrmacher thought that no movement which would keep time, and which could be gotten in such a place, would have power enough to give much of a blow on a bell. But perhaps it would be sufficient for Mr. S.'s purposes. He did not believe, however, that a rim constructed as proposed would give out anything more than a flat, dead sound—not at all like a bell. The better way would be to put a good gong bell either inside or outside of the case to produce the sound. Such bells were sometimes mounted around the stem, but more often attached underneath the bottom of the case, and struck by a hammer projecting from the inside. To protect the movement from the weather, everything should be securely enclosed, except the extreme end of the arbor carrying the hammer—the rest of the arbor, with the spring, etc., being inside.

A NEW PIN TONGUE VISE.

Mr. McFuzee exhibited a pin tongue vise for jewelers. This new device for holding pin tongues will commend itself to every practical workman's bench as a useful tool. The joint of the tongue is placed in one of the transverse grooves; the nut on the handle is then turned, and the pin tongue is firmly clamped in position.

The jaws diminish in thickness by steps from heel to point, and are made of *hardened steel*. They thus form a gauge for filing the width of the joint, securing an accurate fit and saving time.

The tool is thoroughly well made, each being nickel plated and enclosed in a neat box. It is for sale to the trade by Henry Ginnel & Co., 31 Maiden Lane, New York, who are sole agents of the manufacturers.

HOW TO MAKE SMALL CASTINGS.

Secretary of Horological Club:

In No. 12, Vol. XIII, of THE CIRCULAR, I saw an inquiry from F. W. P. about making small castings, such as a jeweler would require; and as I have had much experience in such work, I think I can advise him in a way that may be of use to him and others who are in the same business. My plan is as follows for small and fine bronze castings that I want sound and sharp to detail of mold: I first obtain the proper quantity of the best No. 1 Albany sand, and after running it through a fine sieve, I mix with it about $\frac{1}{10}$ of fine pulverized charcoal and $\frac{1}{10}$ of black lead. After it is dampened and well mixed, you have the best material for moulding fine castings that can be produced. And now we come to the manner of using it. In the first place, let the moulder provide himself with the proper necessary tools. He will want three large tin pepper boxes, which he can procure at any hardware store; one for parting sand—which, by the way, may as well be explained here. The best material for that purpose is the burnt sand cleaned from brass castings when they are being tumbled; it should be sifted very fine and used sparingly. Box No. 2 should contain fine charcoal. Box No. 3 should be used for flour—either wheat or rye flour can be used, as that will make no difference. We now come to the moulding of the pattern or object. I always take a brush and some black lead, and brush the pattern all over with it, which will make it deliver from the sand much better. After the article has been well moulded in the flask, I take a small pointed wire, about No. 50, Stubbs' steel wire gauge, and before opening the flask, prick the sand full of holes on both sides, which will greatly assist in giving vent to the gases which arise from the damp sand when the metal is poured. I now open the flask and draw the pattern, after which I set the flask with the faces close to a hot stove or a flat piece of iron heated red hot, so as to dry the sand in about a half inch deep. When the metal is ready to pour, and *not before*, I dust the faces of the mould lightly with the box of flour above mentioned, close the flask, and pour the metal as soon as possible. There is much that might be said about the proper temperature of the metal at the time of pouring, but experience alone must guide the operator, for every metal will require a different temperature, suited to its kind. While some alloys must be poured at as low a heat as will cause them to be fluid, others will require a temperature far above their melting point. In the case of making brass castings, if the alloy should be heated very far above the melting point, the zinc would be burned away and cause a serious loss of that metal, thereby changing the proportions of the alloy. In closing this article, I would say that I have followed the above directions for fifteen years or more, and have had most excellent success in obtaining fine castings. I would now like to hear from F. W. P. and his plan of casting in fish bone.

Yours respectfully,

W. S. HARRIS.

EFFECT OF PERSONAL MAGNETISM ON WATCHES.

Secretary of Horological Club:

In the May number of THE CIRCULAR I saw an article about the effect of personal magnetism upon watches, from a Philadelphia watchmaker. He tells a customer that, because he is fat and magnetic, he should wear an open face watch if he wants good time. That is true, but it is not because the man is fat, nor because it is an open face case, but only on account of the position of the movement. If we take one of the 14 or 16 size Waltham, or 16 size Elgin, movements made for an open face case, and put it in the case, holding it stem upward, as it is in the pocket, we will see that the balance and escapement are in an almost vertical straight line from the stem. In that position there will be less friction, wear and tear, and the little inaccuracies in the manufacture will have less disturbing effect than would result if held in the position it would have in a

hunting case. If the watchmaker is a good workman and uses care in putting up the open case watch as described, he can get almost perfect time from it, whether the wearer be lean or fat, even if he surrounds the movement with steel springs. I hope, however, that he will not advocate throwing away the steel springs, for then the casemakers could not make money fast enough. I would like to see the watch used by that physician for timing the pulse of his patients, which was said to be "perfectly accurate," and only the size of a pea. I "wonder" just a little about that, as his customer did.

E. A. T.

Mr. Horologer thought Mr. T. was correct in holding that the time kept by a watch could not be effected in any way by the fact of its wearer being lean or fat, magnetic or non-magnetic. An open-face case might be better on account of giving more room for the hands and other parts of the watch, as well as from holding the movement in a position more favorable to easy and accurate running. There is a great deal of humbug talked about the effect of "personal magnetism," but what is meant by that term has no more *magnetism* about it than the heat from a stove, or the blow of a hammer—consequently it could have no influence whatever upon the going of a watch.

There is a difference in the performance of any ordinary unadjusted movement, when carried by different persons, but it is due to entirely different causes. Some men are very quick and violent in their movements, and almost continually moving about, while others are quiet or slow. Some jump and scuffle, ride horseback, or on railroad trains more than others. Some carry their watches where they are kept quite warm, others keep them cool. Some take pains to hang up their watches at night and keep them in nearly the same position all the time, while others leave them in their pockets and throw their clothes down in any way that is most convenient. In short, there are almost innumerable ways in which watches may be caused to vary by the peculiarities of their wearers. But these variations are the results of ordinary mechanical actions among the parts of the movements, and have no connection whatever with the figure or avordupois of their wearers, or their "personal magnetism," whatever that may be—nor with the shape of the cases. Magnetism does, indeed, exert a very powerful disturbing effect on watches, but it is true "magnetism" which does it, and not some imaginary personal attribute under that name. And in every instance the magnetism proceeds from some metallic substance either in the cases or near to them—never from living bodies.

Still, it is often hard to convince people of these plain facts. There is a very general impression among the public that "personal magnetism" has a great deal to do with the performance of pocket timepieces, and some persons become really offended if their beliefs are shown to be utterly groundless. But the watchmaker should never willingly allow such impressions among his customers. Although it may be easier to go with the tide, fall in with prevalent opinions, and blarney his customers to his own profit, as the Philadelphia jeweler did, it will be better for the trade that the truth should be known. An honest business cannot be based on deceit and imposition. Public confidence in our honesty and knowledge of our business is of the greatest necessity to its prosperity, and the less humbug and imposition are countenanced by watchmakers, the sooner public confidence will be secured, and the condition of the trade be bettered.

Lathes and Lathe Work.

BY THE MODEL WATCHMAKER.

IN BUSHING care must be taken to preserve the depths and also the upright condition of the wheels. This is best done by taking the hole nearest the action as a standard, and as there is no better way to arrive at correct results, than to deal practically with such cases as we are called on to meet. So we will suppose we have a Swiss center to bush and upright—I say upright,

because the hole, as a rule, is worn away diagonally from the barrel, as shown by the arrow at *a*, fig. 1. Nine times out of ten closing the hole in the bridge *A* will effect the object, and if closing will do the work effectually, close it; for to bush the hole will certainly necessitate more work; and the rule is, *now-a-days*, to do no more work than is absolutely needed to ensure *safe* results. Here, indulgent reader, let me say that in the practice of your art (or trade as you please), you will find that there is quite as much judgment needed in knowing when to stop on an old watch, as there is in doing any repairs; for, as a rule, if one was to do everything that would add to the performance of the watch in hand, he would not get half paid for his labor. And it is by close discrimination in this respect that a workman can make himself profitable to his employer or not; or if working for yourself, make or lose money. To resume, we will first consider closing the hole and afterward take up the bushing. If the bearing or pivot of the center pinion is worn, we must first get rid of the groove in our pivot, and then go about our hole-closing. At diagram *D** is shown an enlarged cut of the pivot,

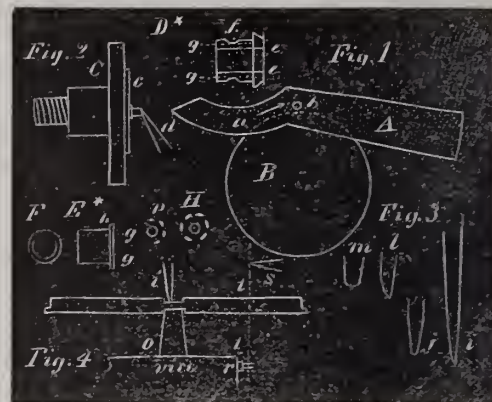

and at *f* the groove cut in by the action of the bridge. If the groove can be turned out and leave sufficient strength of metal in the pivot, this is the best course; but if the cut is too deep, and the turning it out would leave insufficient thickness of metal to resist the wear, or the effect of the center square, a thimble can be made of steel and driven on, or even secured with soft solder. At *E** is shown such a thimble, *F* being an end view, and the dotted lines *g g* correspond to the same in *D**, and represent the sizes to which the pivot can be turned, and the hole in *F* made. Such a thimble is best made from an old file softened, as steel wire is apt to have flaws; consequently when the thimble is forced on it splits. Of course, the thimble must be very thin; and if the shoulder on the pinion does not sufficiently guard the wheel in end-shake, a flange can be left on the thimble, as shown at *h h*. The best chuck for doing this job is the face-plate chuck, so often referred to in these articles. If your center wheel is perfectly true, on applying the wheel to the face of *C*, on which is just enough lathe wax to cement the wheel firmly (chuck and wheel heated to the melting point of the wax), and hold a sharpened piece of pegwood, as shown at *d*, fig. 2; on revolving the lathe the wheel and pinion must come true; the pivot can now be turned and manipulated as directed, except to soft solder on a thimble which is seldom necessary. If your center wheel is not perfectly true in the flat, the first thing is to true it up; as it should be the basis of all the centerings of a Swiss center wheel manipulation. The reason for first *treating* (if I may be allowed to borrow a medical phrase) the upper hole in a Swiss watch is, that this hole has greater reference to the depths than the lower or plate-hole, as it will be seen that any change in this hole affects the depth to both the great and the third wheels. After the hole in bridge *A* is bushed or closed—indeed, after all necessary repair is done at this point, put the pinion in place and screw down the bridge (*A*), then push the center square into place, and taking hold of the square with a pin-vice or slide-tongs, revolve the pinion in the bridge (letting plate turn), and if it does not run flat and true the wheel is not upright; generally by closing to one side the uprighting can be made correct. The best practical form of punch

for closing such holes is a pointed, wedge-shaped punch, as shown at fig. 3, *i* and *j* being about the right size, and *l m* enlarged views; the side *n* should be concave to about a $\frac{1}{16}$ of an inch circle. At *H* is shown, magnified, how the punch should be used; *p* shows the manner when a hole is closed only on one side. On closing a hole in the plate, which is generally countersunk on both sides, a flat-faced punch can be screwed in the vise, as shown at *o*, fig. 4, and the closing punch applied as shown at *i*. If the holes are to be bushed the top is the one, as said before, to commence with; and if worn to one side, the hole should be enlarged on the opposite side with a small round file until it is enlarged as much with the file as worn; *i. e.*, file as much toward arrow *a* as has been worn away opposite. Now broach out the hole to the size of the bush you wish to use, always making your bush of as small diameter outside as consistent with strength, as you might have to remove it and alter the depth. This case is supposable, but should not occur often with a careful workman. After the bush is in the bridge and broached out to fit the pivot, it should be carefully burnished with a round broach; the bridge should be put in position and screwed down. Now comes enlarging the plate-hole for the lower bush. This can generally be done at once, as the wear to one side is seldom enough to be taken into consideration. The hole should be broached to fit the bush intended to be used, when it (the bush) should be driven or screwed in, the latter being far preferable. There are two methods for securing perfect uprightness of the center—the first by means of the universal lathe, and the second by revolving the plate on the center pinion, as briefly mentioned above. To do it with the universal lathe the bridge over the center is put in place and secured fast (but the center wheel left out); the plate is now put in the universal lathe, and centered by letting the center go into the hole in the bridge. The plate is now clamped fast and the hole in the plate bored out with a very slim, pointed tool to fit the bush. This method, if carefully pursued, will make the center perfectly upright. To do this without a universal lathe, broach out the hole to fit a taper bush, and insert the bush from the lower or dial side. Screw in the bush until it is flush with the inside, then broach out the hole of the bush until the pivot of the center pinion will just go in and turn freely without side shake. This bush should be screwed in until it takes up all end shake as well. If now the pinion is put in place and the bridge screwed down, and the center square screwed into your bench vise, as shown at *r*, fig. 4; the center pinion can now be slipped on the center square and revolved, and the plate will revolve on the line *z*, if true. If not true, as can be determined by the point *s*, the hole in the plate can be filed a little to one side, and the bush (as it is taper) can be set further in. This is a kind of cut and try rule, but it will do the work effectually if the instructions are lived up to. Careful attention to uprighting the center wheel is of great importance to flat, thin watches, as it has a tendency to prevent the hands catching. A word or two on center squares. The usual way to put in a center square is to file it to fit, using a piece of material provided with a square already fitted. This method will answer for poor, coarse watches, but anything like a fine watch the center square should be turned to exact size, and the square filed up as has been directed in a former article. Of course, it should be understood that the bit of steel wire used should be hardened and tempered to a springy temper.

Views of Correspondents.

This department of THE CIRCULAR is open for communications relating to the jewelry trade, but the editor does not hold himself responsible for the sentiments expressed by contributors. We invite correspondence, but require that it shall be free from all personalities, and the writer's integrity guaranteed by the disclosure of his true name to the editor. Anonymous communications will not be noticed.

To the Editor of the Jewelers' Circular:

I have read with much interest the article entitled "Retail Dealers and Outsiders," in last month's number of THE CIRCULAR, and

think that the advice given to retailers is good, but to a certain extent impracticable. As you say, the retailer generally buys on time—the reason being that he has not the ready cash to meet his bills, for I do not think that any man would willingly lose 5 per cent. or 10 per cent. on his money if he had the money to pay. If this is so, it takes all his money to run his legitimate business, and, therefore, he has none to spare for things outside his business. The number of jewelers who have money to spare have gone into crockery, pictures and other art subjects. To the general run of dealers it is impossible. The great rivals, or, rather, absorbers of our goods, are the dry goods stores, which, in this city, are enormous bazaars, comprising a great number of departments, which are really separate stores, all combined under one roof, the owners being men of wealth and able to branch off into all lines of trade. A stock of \$3,000 worth of plated goods covers a vast amount of ground and makes a great show and attraction, but what legitimate dealer is going to carry that amount of plated goods in a stock of say ten thousand dollars. It is a known fact that outsiders buy in greater quantities, pay cash and consequently get lower prices from the jobbers and manufacturers. Now, I believe that if people want goods they will buy them where they can get them, and if they can't get them in the dry goods bazaars they will in the jewelry stores—the jobbers will sell just as many goods and get better prices for them. I know the injury this has done, for where we used to sell \$100 worth of plated jewelry we don't sell \$1 worth now. It also makes the gold trade suffer, for when people can get cheap jewelry for 89c., 71c., or catchpenny prices, looking as well as the solid, they will, willingly, for the sake of a variety, spend more dollars in a given time for plated stuff than they would have done in the first place for a solid article which would never have worn out. The truckling to the outside trade has debased the quality of the plate also. Where we used to have plated goods wearing from 7 to 10 years we now have them giving out at the end of a twelve-month. RETAILER.
New York, May 3, 1883.

GLASHUTTE, SAXONY, March 22, 1883.

MR. D. H. HOPKINSON,

Dear Sir:—Thinking it might be interesting, perhaps, to some of your readers to hear a few words about Glashütte and its now celebrated Horological School, and those words from a student at the school, and one whom at present (it is to be regretted) stands alone—the only American attending any horological school in Europe—prompted me to this communication.

After a very agreeable passage over, a delightful stay in London, and a fine trip over the Continent, I reached Glashütte the 12th of last June, and having now been here a little over eight months, I am somewhat able to judge of the school, its workings and its value to the student of horology.

Perhaps a short description of the building and its arrangements might be well to begin with. The school building is new, large and by far the best in the town, and occupies a lot by itself in a central location. On the first floor are the class room, drawing room, janitor's rooms, and the Bibliothek (library and museum). The first two rooms are as usually arranged. The library, not very extensive but continually growing, contains several of the best works on horology, in both French and German. The school takes also the *Deutsche Uhrmacher Zeitung*, and the *Allgemeine Uhrmacher-Journal*, which are read in turn by the students. The museum contains many curiosities in horology, several old watches of note (one made by Abraham Breguet is peculiarly made, has a cylinder escapement, the cylinder of which is cut from a ruby). There are two torsion clocks (one of which runs a year with once winding); work done in the school (going models, traveling clock escapements and watches), and the apparatus used in physics, mechanics and electricity, which make quite a creditable showing.

On the second floor are the director's office, three work rooms and a storeroom. The director's room contains, besides his desk and necessary furniture, two regulators, an electric pendulum and an

electric clock. The battery in the room runs not only this pendulum and clock, but also a clock in each of the work rooms and class rooms, and the large tower clock, besides several bells and a number of "push bells" or "buttons" in various parts of the building. The director's room is connected by telephone with the watch factory of M. Grossmann, and by electricity with the Imperial Observatory at Berlin, from which the observatory time is received once a week.

The work rooms are arranged with long work benches, some for those wishing to stand and some for those desiring to sit at their work. Each student is required to have his own tools, including some sort of a lathe. The school has one large lathe for heavy, rough work, and five large sized watchmakers' lathes with attachments, a wheel cutting machine and a number of other tools for the use of the students.

Students are taken at the school as apprentices, scholars and guests. Apprentices are supposed to know nothing of watchmaking, and begin at the very beginning, learning to file, etc., and they are required to stay three years. Scholars must have worked several years before entering, and are obliged to remain a year. Their first work is generally to make a pair of tweezers, and perhaps several other small tools, flat grinding tool or poisoning tool; then a "going model" of an escapement, either cylinder, duplex, lever or chronometer. After this he makes the escapement for a traveling clock; these escapements are either lever or chronometer, are jeweled throughout, have compensation balances and Breguet balance springs. He next has watch work, which may be to make a watch from the rough or to complete an unfinished movement. In either case he has the pinions to turn, staffs to make, the entire train to plant, the jewels to set, escapement to *make* and plant in the plate, the balance to cut, true and poise, and the balance spring (always Breguet) to put in, the stem winding mechanism to fit in, bridges, regulator, clicks and click springs, hair spring collet and stud, in fact the whole watch to make from the rough, gradually building it from the foundation. Repairing is also done at the school. Guests must also have worked several years at the bench, and are required to stay six months. It is rather optional with them what studies they take up and what their work in practice is to be, providing they are capable of such work.

The practical work is under the charge of Herr Hesse, who has two assistants. He needs no other recommendation than that he was for eleven years foreman and adjuster for M. Grossmann.

The theoretical work is mathematics, physics, mechanics, theory of watchmaking, languages, and mathematical and mechanical drawing, which includes large colored drawings of the different escapements and varieties of the same, drawings of depthings and "studies."

Mathematics, physics, mechanics and drawing are taught by Herr Strasser, who is a very able man indeed in theory; but more than that, he is a first-class practical workman and is a manufacturer of astronomical clocks and complicated horological mechanisms. He therefore understands the wants of the watchmaker, and the student is not burdened with theory inapplicable to watchmaking, nor is he left with bare theory alone, for explanations make clear its application in practice.

Theory of watchmaking and French are taught by Director Lindermann, who was for thirty years a watch manufacturer at Neuchâtel, Switzerland.

M. Grossmann teaches English, and, as president of the council, constantly visits the school, and has an ever watchful eye over its workings.

It is thus seen that the school has a very competent corps of instructors, and certainly presents many enticing features.

But they cannot make *horologists* of everyone, nor is this the object of the school. It is rather to give the expectant watchmaker a good general knowledge of watchmaking in both theory and practice—those two factors which must work hand in hand, the one being maimed without the other. The student is taught the *use* and *care*

of tools and correct modes of working. Here he learns to make every part of the watch, while the schools of Switzerland and France are specialty schools. Besides, he becomes acquainted with the celebrated Glashütte watches and their system of manufacture, and he has an opportunity of visiting the different factories and the makers of the escapements, jewels, balances, pinions, etc., who are very kind and obliging, and one may see their tools and modes of working and the work produced, much of which is unique, found only in these watches. In fact, one lives and breathes in an atmosphere of horology, and the amount of knowledge he can acquire is limited only by the time he can spend here, for Glashütte, its school and its renowned horologist present an unexhaustible supply.

Watchmaking, as an art or science, or both, cannot be acquired in a year or several, it is a life-long study; but I am confident that one can learn more here in a given time than under other circumstances in double the time. But much, very much, depends upon himself.

It must not be overlooked that he also acquires the German and considerable of the French language. One coming here without any knowledge of the German language will find it much to his disadvantage at first, as he will be unable to take up the theoretical work. But he can have the practical work and drawing at the school, and have time to study works on horology and to acquaint himself with Glashütte watches, their manufacture and characteristics, and when he has German enough enter the classes.

There are several good watchmakers' lathes made here, a number of small bench tools, besides counting and measuring instruments and mechrometer gauges, and rules in several varieties. The metric system is used entirely.

Taking all into consideration I think Glashütte is a very good place indeed to learn, and with a thorough knowledge of the German language is still better, and leaves little to be wished for. It is to be deeply regretted that we haven't in America a similar institution to this horological school. Such an institution is even more needed there. Here or in Switzerland one has a chance of getting into these small factories as apprentice, volunteer or guest, and learning thoroughly and correctly. In America all is different. There are no small manufacturers, and the great watch factories are hardly the places to learn, and it is a difficult matter to get a place under a first-class, thorough workman; so that the "watchmaker," left alone to grope along in the dark, is so often brought up in the way he should *not* go, is "deformed, unfinished, and sent before his time into this breathing world scarce half made up."

But I am glad to see that THE CIRCULAR is not in favor of founding a horological school without sufficient funds and a competent corps of instructors to make it a success. When these requisites are at hand then go on in the good work, and do the work so well that

"Amerika, Amerika, ist über alle,
Alle in der Welt."

Very respectfully,

SIDNEY C. SMITH.

Sight.

WHAT THE OPTICIAN SHOULD KNOW ABOUT OPTICS.

Based upon an extensive hospital experience in Austria, Germany, England and New York. By C. A. BUCKLIN, M. D., New York. Author of Detection and Correction of Visual Imperfections, Cause and Cure of Cross Eyes, Effects of Color on Distance, and Monograph on Astigmatism.

Continued from page 120.

BARTON LANDING, VT., April 16, 1883.

DR. C. A. BUCKLIN,

Dear Sir:—I have been a careful reader of your articles on "Sight," in THE JEWELERS' CIRCULAR, and have learned a great deal from them. There are two young men here who do not see as well as others, and I find upon showing them the diagram that they have astigmatism, one much more than the other, and both appear to be a little far-sighted. I propose to test their eyes according to

your direction in THE CIRCULAR, and report the result to you. Have you any further directions or questions to be answered that will help me to the correct measurement of the defect?

Yours truly, A. F. B.

A full statement of questions to be answered and facts to be ascertained will be found in the May number. Be sure and give the result of your experiments with spherical lenses and the nature and strength of the concave or convex lens required to reverse the dark line. Always give the acuteness of vision without glasses, and with the best spherical lenses, testing each eye separately; also the appearance of the radiating lines with each eye.

BOISE CITY, April 6, 1883.

To the Editor of the Jewelers' Circular.

DEAR SIR—I would like to know something about my eyes, and as there is no optician at this place, thought I would write; am watching the experiment on Mr. Dollenmayer with a great deal of interest.

The following are answers to the questions in February number (1883), page 28.

Answer to first question: Cannot read block letters in June number (1882), until I go within six or seven feet, and then can read LXX line, right and left eye the same; with both can see slightly plainer. Can read the line XX (June number, 1882), at three feet, right and left eye same, both together a little plainer.

Answer to second and third questions: Convex lens makes vision worse; weakest concave lens in store No. 36; can read LXX at ten feet, right and left eye same, both together slightly plainer. Can read XL line (June number, 1882), at twenty feet, with number 18 concave. This number seems the best I can find.

Answer to fourth question: Horizontal lines at eight feet very black; top of vertical I cannot see. At four feet horizontal lines same, only plainer; can see top of vertical lines, but they are dim. At two feet all lines equally black, both eyes same; both together slightly plainer.

Answer to fifth question: No. 18 concave makes radiating lines look same at twenty feet, as at eight feet without glasses, only a little plainer; all lines equally black with No. 18 concave at six feet.

Can read as fine print as anyone at reading distance; have been at watchmaking for nearly four years; think I was born near-sighted, but eyes never hurt as they do now when I read. Since I have worked at the bench my eyes are all the time getting worse; they are usually blood-shot, and when I read or work (especially by lamp light), they feel as if they were swelling up and pushing eyelids out, and burn; some days eyelids seem very heavy. Do you think an out-door business would be of benefit to my eyes? Do you think it injurious to stay at trade? Physically am not as strong as most boys of my age, 19. Consumption is only "heir-loom" in family. By answering these questions you will greatly oblige, Yours, etc.,

E. B. B.

P. S.—Bright sunny day tested eyes.

The above letter is very complete with one exception, the writer fails to state what number concave glasses is necessary when he is looking through concave 18 to reverse the dark line in the disk from a horizontal to a vertical position. He also fails to state whether he wishes a pair of lenses for near work or for distinct distant vision. I am quite sure that he is myopic $\frac{1}{8}$, and has in addition a myopic astigmatism of about $\frac{1}{8}$, the sharp curve being in the horizontal meridian.

The watchmaker's trade is not a good one for myopic eyes. Out-door employment would benefit your eyes very much, but it would not supply the place of proper lenses. If you will make the necessary additional answers to questions in your next, we will try and assist you.

Where the vertical lines of the astigmatic disk are the darkest, always state if the lines to the right or the left of the vertical are the most distinct. If they are equally indistinct, say so.

Where the horizontal line is the most distinct, state if the line above it on the right or left side are the most distinct.

For all further instructions turn to the May number (1883) of THE CIRCULAR.

WILSON, Kans., April 25, 1883.

To the Editor of the Jewelers' Circular:

SIR—Eureka! Eureka!! I have found a man who can make the blind to see; I can now almost see a fly on a needle a mile away. But laying all jokes aside, I am the happiest mortal in town, for now I can "see as others see." What is the matter with your eyes, are they sore? Why no, man; I am just beginning to see now; I never saw such beauty before. No one but one whose eye is myopic and astigmatic can ever realize how different things look with and without properly adjusted glasses. Let all those whose eyes are defective call on or write to my benefactor, C. A. Bucklin.

E. Y. DOLLENMAYER.

The case which the following letter describes was published in the May number (1883) of THE CIRCULAR. Those who are thoroughly interested in the subject will be surprised to hear that the combination of lenses which were roughly guessed at, were just the thing for his distant vision. I feel certain that if the axis of the cylindrical lens requires to be set at 15° for the left eye, instead of horizontal, that there must have been one or two radiating lines to the right of the vertical line, which appeared darker than any of those to the left of the vertical line. I think that a cylindrical combination could also be found which would improve his near vision.

I am rejoiced to see that our efforts to assist the watchmakers to a more thorough understanding of practical optics is being well received and carefully considered.

WILMINGTON, Del., May 10.

DR. BUCKLIN,

Dear Sir:—Since writing the article so kindly noticed by you in the last (May) number of THE CIRCULAR. I have come into possession of a small case of trial lenses, containing a limited number of cylindrical lenses, also, your card, published by the Spencer Optical Company, and have therefore been enabled to extend somewhat my observations.

We are within easy reach of specialists, having one in our own city, and I always advise customers who are difficult to suit with glasses, to consult one. But, as it is the aim of THE CIRCULAR to impart practical information, and, as all knowledge is but the aggregation of individual experiences, I have been encouraged by your kind invitation, through the columns of THE CIRCULAR to report this case as fully as possible, so that its publication, together with your generously imparted information on the subject, may be available to others who are having, or who may have, similar experiences.

I. Age, 53 years; occupation, watchmaker. Commenced about three years ago to wear No. 36 cx. glasses, by advice of an oculist. Has been using higher numbers since, until now No. 60 cx. glasses produce the most comfort for reading.

II. When reading, the eyes smart and burn, and become watery, requiring the frequent use of a handkerchief to dry them.

At times the eyes are very much inflamed, showing the red veins very distinctly, and feel as if sand was in them; the inflammation comes on as suddenly as if struck by a grain of sand or other hard substance.

A bright star in the heavens or a bright light at a distance, has no definite outline, but has a sparkling appearance, with lines radiating in every direction.

Sometimes the local light in the reading or sitting room appears as if surrounded by a halo.

Floating specs similar to those described on page 50, April number (1883), of THE CIRCULAR, are frequently seen, especially on looking through a microscope, or through a pin hole in a card.

At times, when reading, a floating, grayish, foggy disc, about the size of a silver dime, appears on the printed page, before the center of the eye, or in the direct line of vision.

The pin hole in the card does not appear clear, but has a dazzy appearance. At a distance of fourteen inches from the eye, four distinct holes are seen, arranged, as nearly as I can describe, in the form and proportion of a three-leaf clover with a short stem, the upper leaf inclined slightly to the left.

All distant objects, such as buildings, trees, etc., have a flat, slightly confused, and tame appearance, but are brought out in beautiful relief in the combination named below.

It is difficult to read or write unless the paper is placed in a position or plane perpendicular to the line of vision.

It is also difficult to get a common carpenter's rule in such a position as to see the lines distinctly for measuring purposes, as the lines become confused and run into each other.

The subject is afflicted with chronic rheumatism.

III. The last line of block letters in June number (1882), cannot be seen distinctly beyond ten feet, and ex. lenses makes the vision worse. At twenty feet number 60 ex. lenses make the line readable, but a combination of number 72 *concave* S, with a number 60 *concave* C, axis 15° to right downward from horizontal, brings out all of the letters and lines clear and distinct.

With the same combination, the C lens axis marking 35° right from perpendicular, the radiating lines have a double or shaded appearance.

IV. Habitual reading distance, eighteen to twenty inches. Can use 60 ex. S with comfort from sixteen to twenty-four inches distance. Beyond twenty-four inches *any* ex. lenses increases the obscurity and confusion of vision.

For bench work (watchmaker's) or writing, the distance being about ten to twelve inches, No 28 or 30 ex. S are required.

V. This question seems to be as fully answered as I can make it without much repetition, in my former communication.

I. You should carefully examine and see if a convex cylindrical lens combined with a suitable spherical lens will not relieve his near vision.

II. Few of the peculiar phenomena your customer exhibits are due to his visual defect. They are due to inflammatory changes brought about by rheumatism. When his eyes are bad or his rheumatism troubles him, he should take twelve drops of saturated solution of iodide of potash in a wine glass of Vichy water three times a day, after eating.

If this will not remove the trouble, he should take one-half teaspoonful of the wine of colchicum every three hours till it acts as a cathartic; then stop it and follow it up with the iodide of potash, as above directed. The colchicum will make him very sick, but his rheumatism will go like magic.

III. In indicating the axis of cylindrical lenses you should commence at the left hand of the person wearing the glasses, for each eye. As on a clock dial, commence at nine o'clock, 0°, follow the hands to twelve o'clock, 90°, three, 180°.

IV. The shaded appearance of the radiating lines is always present when a near-sighted, astigmatic person looks through a cylindrical lens, the axis of which is not in the proper position.

In contrast with the intelligent inquiries we are constantly receiving, I publish a letter from an optician who will not take the trouble to read THE JEWELERS' CIRCULAR. This letter represents the *average* degree of intelligence which existed among the trade before THE JEWELERS' CIRCULAR began to popularize optics.

We have a gentleman (a friend of mine) in our town whose sight is very bad. It is nothing wrong with his eyes, yet he cannot be satisfactorily suited with glasses. He tried several watchmakers; I believe he never had his eyes examined by an optician.

The gentleman is about 80 years old, his eyes look clear, but he *cannot* distinguish a person, either far or near.

The water runs out of his eyes freely.

This man has done me of late many favors, and I intend to pre-

sent him with a pair of glasses. Please tell me by returning mail what you think good for him, and state the price. I should be very glad if I could help him. Please answer without delay, and then I shall order the lenses and a pair of steel frames.

There was a long article in the *New York Sunday Times* on "Eye Glasses," which was without point or sense. The writer thought that the public wore eye-glasses because they were stylish. That spectacle frames were very much better for the eyes.

The fact of the matter is there is a small proportion of cases for whom eye-glasses do not fill the necessary requirements. Those who require lenses which can be just as well mounted as eye-glasses, and who can comfortably wear an eye-glass, will find them in all cases more convenient, and in many cases the ease with which they are removed stimulate people who have beginning presbyopia to remove them always, as soon as they are not absolutely required by the nearness of the work. In this manner they continue to exercise their accommodation much later in life than they do where they are obliged to remove and fold a pair of steel frames.

Most every practical optician knows already what frame will hold the lenses most satisfactorily for his customer.

Any department in optics our readers would like explained will receive prompt attention.

Any questions they may wish to ask regarding persons blind who can still tell light from dark, cross eyes or other eye troubles we will be pleased to answer.

Repairing Watches.

THE BAD rate of a watch may frequently be traced to its imperfect jewels. The repairer should always carefully examine every jewel in a watch taken down for repairs, and if he finds one with hole too large, or "out of round," that is, much wider in one direction than in another, it should be replaced by a good one, to be done as follows: If the depth is correct, notice whether the jewel is above or below the surface of the plate; if it is either, then knock it out and cement the plate or bridge on a chuck in the lathe, being careful to get it on true by the hole lately occupied by the jewel; by means of a burnisher raise the burr that holds the other jewel in, and if a jewel can be found of the proper size and thickness, and the hole not too large, it can readily be "rubbed in" with the burnisher; if the hole is too small it can be opened. The chuck on which the article is cemented should have a hole from a quarter to a half an inch deep in its center. If no jewel can be found of the right size and thickness, select one a little too large, enlarge the hole sufficiently to fit the jewel in, and then proceed to fasten it. If the jewel is broken, of course the same remarks apply to replacing it with a good one as to an imperfect one.

One difficulty that the watchmaker has to contend with in selecting a jewel from the indifferent lot supplied by some dealer is to find one the hole of which is in the center of the jewel. If a jewel is not true, or, rather, if the hole in it is not in the center, it must be cemented into a chuck in the lathe, trued up by the hole, then turned off with a diamond cutter, and the chamfer carefully trued up and polished again; while in the lathe it can be turned down to fit the hole in the setting or plate; the shellac is to be removed from the plate with alcohol. In many instances a chuck will have to be turned up to suit the particular job to be done. Care must be taken in opening, or the jewel will break or chip around the hole. The corners must be carefully rounded by a piece of wire larger than the hole, the end of which is conical. It will take but a moment to do this, but if care is not taken too much will be taken off.

GOLD ALLOY.—An alloy of a fine appearance after coloring is made as follows: For 18-karat, 18 gold, 3 silver, 3 copper; 15-karat, 15 gold, 3 silver, 6 copper.

The Jewelers' League.

President, G. T. WOGLOM, Of Woglom & Miller.
 First Vice-President, JAMES P. SNOW, Of G. & S. Owen & Co.
 Second Vice-President, HENRY HAYES, Of Wheeler, Parsons & Hayes.
 Third Vice-President, WM. C. KIMBALL, Of H. F. Barrows & Co.
 Fourth Vice-President, AUG. KURTZBORN, Of L. Bauman Jewelry Co.
 Secretary and Treasurer, WM. L. SEXTON, Of Sexton & Cole.

EXECUTIVE COMMITTEE.

ROBERT A. JOHNSON, Of Colby & Johnson.
 JOHN D. LYON, Of Lyon & Hardy.
 JOSEPH B. BOWDEN, Of J. B. Bowden & Co.
 JAMES D. YERRINGTON, Of J. D. Yerrington & Co.
 SAMUEL W. SEXTON, Of Sexton, Smith & Co.
 C. B. BISHOP, Of Carrow, Bishop & Co.

EXAMINING FINANCE COMMITTEE.

CHAS. G. LEWIS, Of Randel, Baremore & Billings.
 C. G. ALFORD, Of C. G. Alford & Co.
 G. R. HOWE, Of Carter, Sloan & Co.

THE JEWELERS' CIRCULAR is the *exclusive* official paper of the Jewelers' League, and has been selected for the publication of all matters of interest pertaining thereto. Letters or inquiries pertinent to its business or purposes, and which might interest the trade or inquirers, will herein be answered. Address *Jewelers' League, Box 3,444, P. O., New York*, or the office of THE CIRCULAR.

At the regular meeting of the Executive Committee of the League, held May 4, some forty applicants were admitted to membership, increasing the number of members to 2,580. The fact that the League has had no death losses to record for a long time has led many members to imagine that they have been overlooked. As a consequence the secretary is in constant receipt of communications from them asking when the last assessment was made, and if notice was sent them. They express great anxiety lest they should be dropped from the rolls for non-payment of assessments. Members may be assured that the eagle eye of the vigilant secretary is fixed upon each one of them, and when it becomes necessary to make an assessment they will be duly notified, not once simply, but a sufficient number of times to convince them that money is wanted. No member will be dropped from the rolls until he has been given abundant opportunity to "make himself solid." He is not at all discriminating in the distribution of his epistolary favors, nor is he sensitive about doing it, but, when the time comes, he sends forth his notices with a degree of impartiality that is beautiful to contemplate. Still, we may suggest, to those who are so anxious to pay, that the reserve fund is always open to receive contributions; while it is increasing gradually from natural accumulations, there is not the slightest objection to swelling its excellent proportions by voluntary contributions.

The Executive Committee, on whom falls all the responsibility for the management of the League, hold their meetings at stated intervals, and transact such business as comes before them with that dignity and decorum that characterizes their actions in private life.

We would again call attention to the official badge that has been prepared by one of the members and adopted by the League. It is a beautiful and appropriate decoration, and can be obtained on application to John Frick, of this city.

The following applicants have been admitted to membership:

H. Bub, W. J. Durfey, J. Goldsmith, S. Hersfelder, C. F. Koester, M. J. Lissauer, E. McDonald, A. H. May, S. Mosbacher, H. Z. Oppenheimer, R. H. Platt, C. R. J. Stahl, New York City; D. G. Ackerman, W. Edge, C. M. Hopping, Newark, N. J.; G. E. Adams, O. A. Drinkwater, Boston, Mass.; W. D. Addison, W. J. Doherty, Baltimore, Md; V. L. Burghoffer, W. I. Hudson, J. L. Hutchinson, Chicago, Ill.; P. Carroll, H. B. Houston, G. O. Kingston, Philadelphia, Pa.; W. Broadbent, Utica, N. Y.; F. Carruth, Plattsmouth, Neb.; N. A. Cushman, E. F. Rose, Taunton, Mass.; W. Davies, New Bedford, Mass.; J. N. Hugo, North Attleboro, Mass.; F. M. Finch, St. Paul, Minn.; J. B. Grimshaw, Driftwood, Pa.; L. S. Lowenthal, Bradford, Pa.; P. W. Hager, Louisville, Ky.; J. Logan, Cleveland, Ohio; B. Schmidt, Jr., Albany, N. Y.; J. H. Stutterd, Syracuse, N. Y.; A. C. Stone, Providence, R. I.; E. G. Wright, Putnam, Conn.

Ten applications referred for investigation. The resignation of one member accepted.

Amount in General Fund, \$3,416.17.

Amount in Benefit Fund, \$4,892.50.

The Industrial Organizations of France.

GUILDS AND MASTER UNIONS.

HE WHO desires to correctly comprehend the organization of industrial labor of the middle age, must necessarily go back to the institutions transmitted us by antiquity, especially by Rome.

In the so-called "classic" antiquity, industrial pursuit was the part of slaves; war, science, arts, statesmanship and idleness, that of the free citizen. In this respect, old Greece as well as old Rome, stand on the same level. At the time of Pericles, 15,000 citizens of Athens disposed over 400,000 slaves, and made them work. The slave was property which could be sold, alienated in any manner, or killed, according to the possessor's whim. In the communistic state of the Spartans, he was hunted like the wild beast of the forest if he increased too rapidly. In Rome, Cato recommended to do away with slaves that had become too old for work, that they should not become a burthen for maintenance. And not one of those great lights whose works have become the admiration of all times and all peoples, uttered a word of reproof, no one spoke a word of defense for the natural and human rights of those who, only by the adversity of war and pillage, had become slaves. Aristotle, the great philosopher and teacher of Alexander the Great, explains in his works how nature created two kinds of people—those that were born free and to command, and those born in bonds, slaves, subjects born to obey. Admitting that their lot was a passable one by owners of the intelligence of Aristotle, because he manumitted them all at his death and recommended them to the care of his friends, they were none the less property, beyond the pale of the law, like the animals in the stable, and although, when liberated, they were freed from the yoke of immediate dominion, yet the freed slave was not by any means a free citizen, and only a freedman, ranking far beneath the free. History informs us that a few of them became celebrated teachers, poets, or authors, but they were exceptions; we will generally find them performing the same labor as when slaves, and the freedmen are the actual nucleus of the free tradesmen, who did not stand under the immediate dominion of one owner. But if we wish to understand their social position thoroughly, let us listen to the first geniuses of classic antiquity, Xenophon and Plato, Aristotle and Cicero. "Vile mass," apostrophizes the former, "conglomerate heap of cobblers, masons, kettlesmiths, fullers, peddlers and green-grocers, among whom all is disorder and crime." The noble Plato is no more just toward tradesmen: "Nature created neither cobblers nor blacksmiths; such occupations debase those who follow them; base hirings, nameless miserables, who even by the very nature of their callings are excluded from political rights." Aristotle calls them "people whose occupation is a debased one, and with whom virtue has nothing to do." Cicero wrote in his admirable work "On Duties," the following lines, which should call the blush of shame to the cheeks of entire humanity: "As debased and dishonorable is to be considered the calling of the hired laborer, and all those whose labor can be purchased; because the recompense is only a covenant of servitude. Those who purchase in wholesale to sell again in retail, are not to be esteemed any higher, because the vendor profits by lying, and nothing is more abominable than deception. Every trade is dishonorable and to be detested; there can be nothing noble in a grocer's shop or workshop."

Thus thought and spoke the nobles and most intelligent of their times; what must have been the thoughts of the masses?

Although excluded from political rights, tradesmen played a great part in the state of the old Romans, and one which stands almost in direct contradiction to their detested position. At a very early date they possessed their own regulations, and a well-perfected organization from which the guilds of the middle age descended afterward. It is said that Numa already issued regulations concerning the Roman trades unions; their origin, consequently, is lost in the fabled times of the Roman kingdom. Under the Republic and Empire we find them as powerful instruments of the state government. The interior branches of public service were organized with their aid,

armies fitted out, the great constructions of public utility and luxury erected, and the city provisioned. Still, with all this, they were political outlaws, and were kept in strict dependency. Their responsibility did not alone extend to their actions, but even to those of higher power,—losses in consequence of shipwreck, conflagration, piracy, insolvencies of collectors of revenue, etc. This responsibility is counterbalanced by certain privileges, especially for the forcible collection of duties. The unions were divided into branches (*collegia*) of 500 to 600 members, and extended over the whole empire. Each of these branches chose its superintendency. They became very rich in the course of time, since all the property was held in common until they were plundered by the later emperors. In the beginning of the fourth century these corporations were so thoroughly ruined that Constantine and his successors sought to reconstruct them. The new organization recalls the strict and close forms of the monasteries; also the trademan, similar to the monk, belonged to the corporation for life; his relations were inherited by it, his time, his labor, his body and soul, so to say, belonged to the corporation. If he left it and became a fugitive, he was forcibly brought back. But even these strict forms were unable to restore trades unions to their former eminence, and the most of them foundered in the great shipwreck of the Roman Empire. Others survived; influenced by the religious tendencies of the middle age, they experienced important modifications, but up to the time of the general abolishment of industrial corporations and guilds, especially in Romanic countries, the old origin in the Roman corporations can plainly be recognized.

If we throw a glance at the middle age, and single out those of France, because from hence emanated the impulse of free trades, we will find the following:

The French guilds, or "Corps de métiers," were unions of the masters of the same trade of the same place. Although these guilds differed somewhat from each other when compared to other localities, still, the objects of the organizations were everywhere the same. Their number of membership was sometimes strictly limited, and no new member could be admitted until a vacancy occurred by death or resignation. Everywhere, the candidate soliciting admission into a guild, must belong to the Holy Apostolic Roman Catholic Church, and be a citizen of the town. In several corporations, the candidate must be the son of a master belonging to the guild, the guild, in order to become a member. The candidate had to furnish proof of having served the requisite time of apprenticeship, worked as journeyman during a certain number of years in the place, and possessed the necessary capacities, that is, he understood his trade. For this purpose he had to submit to an examination, and always hand in a masterwork constructed by him. If he was finally found to be competent—"souffisant et idoine"—and if there were no obstacles to his reception, he was required to pay a certain sum for the privilege of becoming master, the smaller portion of which belonged to the guild, and, of course, the lion's share was devoured by royalty. The son of a master need only pay one-half of this sum.

Repeated attempts have lately been made to boast of the excellencies of the apprentice system under the old guild laws. Undoubtedly, these strict prescriptions were at first well meant, but their boasted advantages were more than counterbalanced by the malice, the chicanery, the plundering of apprentices, which characterized this system of those days. The period of apprenticeship varied without plausible reasons in the different trades and places, and was unexcusably long; five, six, seven, yea, even eight and ten years, the embryo tradesman was compelled to work as apprentice without recompense. It was not demanded everywhere absolutely that the master should lodge and feed the apprentice "out of his pot." If the latter desired to leave before completing his time, he must purchase himself free.

The master's son was generally not required to comply with these stringent laws; it sufficed if he had worked for two years in the shop of his father, as if talent and skill was an heirloom that could be handed down from father to son. Generally, the master could not

employ more than two apprentices; in many places only two if one was a master's son or relation of the master's. It appears that in exceptional cases the apprentice received a small salary, because in a statute of the guilds there is an express prohibition from paying salary to an apprentice.

The apprentice, after having served his time, became journeyman. When he was sent to travel, the masters of the guild, beside his certificate, gave him numberless advices, what places he should visit first to perfect himself, etc. Like the sons of masters who had to pay only one-half the reception fee into the guild, the journeyman married to a master's daughter paid only one-half the tax.

The guild deliberated over their interests, sometimes in open meetings, in the presence of a police officer, at other times the guarding of their trade interests was confided to specially elected committees. Non-attendance at these meetings was in several statutes punished with fines and the temporary suspension of mastership.

Every corporation chose one or more sworn persons as inspectors, to "guard its interests." The office of these sworn members—*guardes jurés*—was called "*jurande*." Different guilds had different modes of electing them, and their number also varied essentially—two, three, five, six. In Andely two journeymen assisted the master *jurande*; masters' wives were also appointed to office in several trades. The office of *jurande* occasioned much loss of time, since the members had to swear in the journeymen accepted as masters, examine and judge of their masterpiece (whence this expression?), visit the workshops, inspect the quality manufactured, and even watch over the "masses" and fairs, to prevent the sale of any unauthorized goods. The master appointed as *jurande* was forced to accept the office, if he did not prefer to have his rights of master suspended for a shorter or longer period. Aside from these guilds and corporations there existed also the so-called "fraternities," of a religious tendency. They figured in religious processions and other festivities, marching under their own banners.

In Paris six guilds enjoyed special prerogatives above the others. These were the cloth merchants, grocers, fancy-goods dealers, furriers, brokers and goldsmiths.

We finally come to another office, which, although it was abolished by Henry IV. in 1581, appears to have been of great importance. It is the office of the "grocers' king," *roi des merciers*, who was to a certain extent royal trade minister. He bestowed the masterships, maintained a numerous retinue for the inspection of the shops, factories, storehouses and fairs, confiscated illegal goods, prescribed punishment, etc. Already Henry III., and afterward Henry IV., arrogated to the crown the attributes of the grocer king; the right of conferring mastership, although left to the guilds, was declared to be a royal prerogative, and afterward Louis XIV. declared openly that only *he* was entitled to appoint a "*maitre des arts*."

It would lead us too far if we were to enter into the labyrinth of the thousands of rules and prescriptions of the industrial associations. Everything was prescribed officially, the length, breadth, number of threads of cloth, etc., and everything defective was confiscated, the master or dealer mulcted, his products perhaps exposed in the pillory, in case the master was not pilloried himself. Similar rules governed the working time, etc.

Our sketch on the organization under the old regime would be incomplete if we did not speak of the many disputes and processes of the single guilds among each other, and which, not taking into account the time lost, annually devoured beyond 800,000 livres. Cooks and restaurant keepers, knife-handle and knife-blade makers, tailors and dealers in "old clo'," were engaged in never-ceasing feuds with each other, on account of invaded rights and privileges. These processes dragged through centuries without any mutual advantage, consumed their thousands and made their industrial products dearer, without benefitting any one but the lawyers. This was called "division of labor."

If we sum up the past of trade organizations in a few terse sentences, we are forced to acknowledge that we have seen nothing but chicanery, pusillanimous jealousy and servitude, suppression of every act and thought of the independent man, privileges, monopolies and plunder—that is the sum total of “the good, old times.”

Extract from “The Construction of a Simple but Mechanically Perfect Watch.”

BY MORITZ GROSSMANN.

THERE IS no absolute mechanical necessity for giving a certain thickness to the plates of the frame, but the pillar plate ought to be sufficiently thick to afford a safe hold for good strong screws, and to contain the pallet and scape wheel so as to be a trifle below the surface of the plate. The upper plate ought to contain the center wheel in its countersink flush with the inner surface of the plate, and, besides, a solid bearing for the upper pivot of the center pinion should be left. To satisfy these requirements it will be found advantageous to make the pillar plate of a three-quarter plate or skeleton movement 0.06 of its diameter. The upper plate ought to be about 0.035 of the same diameter. These proportions, of course, apply only to watches of a mean height (say 0.16 or about one-eighth of their diameter); a flat watch, having a weaker mainspring, and consequently less strain on the frame, and less pressure on the center pinion, can bear a reduction of these thicknesses.

The material of which the frame is to be made, is also worthy of consideration. A certain degree of elasticity and hardness are required for the purpose; beside it ought to offer the least frictional resistance to the movement of the pivots, and oppose the greatest durability to the wear resulting from this motion.

For this last reason steel is out of the question here; beside, it could not possibly be protected against rusting, and magnetism might endanger the rate of such a watch in a most serious way. Still, I will remark here that I had an opportunity of observing for many years a good watch, constructed by a German maker, before jewel holes were conveniently to be had. To obtain greater durability he had screwed steel bushings into the plate for all the pivots, the escapement included, and these steel holes, well hardened and polished, showed almost no wear at all after a performance of more than fifty years, and kept the oil remarkably well.

Brass fully answers all the requirements of a good watch frame, if its greatest hardness and durability is imparted to it by sufficient rolling or hammering. Hammering is preferable to rolling, because the latter process stretches the metal, an effect which does anything but improve the quality of the material. Small rollers stretch the metal more than large ones. I have made a series of rather tedious experiments, in order to find out the best way of obtaining the greatest possible density of brass. For this purpose I constructed a small tilt-hammer of about three pounds weight, striking five to six blows in a second, and adjustable to perfect parallelism with its anvil. I found that a strip of brass worked with it did not show the slightest increase in breadth and length—a proof that the considerable amount of mechanical work bestowed upon it had acted exclusively in the right direction. By comparison, I found a strip of one mm. thickness reduced to 0.9 mm. through this vertical hammering, and it was equal in elasticity to a strip of 3 mm., reduced by rolling to the same thickness, but which became extended by the process $2\frac{1}{2}$ times its former length. Thus it is clearly seen that the work done by the rollers is chiefly expended in spreading the metal, and that only a small portion of it serves to increase its density—the real object in view. This stretching process is a source of great injury to the solidity of the metal. It not only produces fissures at the edges of the strips, but it also increases the size of the smallest defects (flaws or holes) in the metal, while vertical compression

rather helps to reduce them. I could not continue my experiments on a larger scale, because the little tilt-hammer was the maximum of what a man can drive with a foot wheel, and I had no machine power at my disposal; but the result obtained led me to the conclusion that the method generally used for attaining the necessary density and elasticity is altogether wrong. I should prefer to stamp out the rough plates and other parts with punch and die from the common, hard, rolled sheet brass to be bought in any shop, allowing about 10 per cent. extra thickness for reduction by hammering. Each part ought then to be put on a flat anvil and submitted to the powerful blow of a falling block, adjusted exactly parallel to the face of the anvil. Such a method would offer the further advantage of making both faces of the block piece quite smooth and level, so that not so much need be taken from it as when prepared in the ordinary way. For manufacturing on a large scale, it would perhaps be more advantageous to operate with a press, as we see them in the mint. If we consider the perfection with which medals and coins are stamped, it is permissible to conclude that a similar machine could turn out a pillar plate with its sunk part and the shoulder for the casing, and that in such a perfect form that would render even stoning superfluous.

As a rule, the plates of English watches are very soft, owing to the bad practice of the gilders to expose them to a high degree of heat. The reason for such a proceeding is unknown to me, but it requires no proof that a very good gilding can be effected without heating at all. The upper plates, too, are generally too thin, and especially with the screwed jewels, the screw-heads of which are sunk into the plate, they give a good deal of trouble to the repairers, owing to the very small amount of stock left for the screw-threads in that soft metal.

For some years there has been an increasing demand for the so-called *nickel movements*. These are made of German silver, and that incorrect denomination is derived from nickel, one of the chief constituents of this alloy. There can be no doubt that German silver is a first rate material for watch work, from its elasticity and hardness, and those desiring to go deeper into the subject, I refer to the particulars of my experiments published in my “Essay on the Detached Lever Escapement,” chapter 14. A nicely polished and grained German silver movement is certainly a handsome looking article, and its surface resists remarkably well all atmospheric influences, while brass needs to be protected by gilding. Still, when touched in a careless way with perspiring hands, very ugly black stains are the result, and in this particular it is inferior to brass.

In all other points German silver offers no advantages over brass, and it must be said that it is very injurious to the eyes of those who have constantly to work at finishing those brightly polished movements. Brass, at any rate, is well prepared, is so nearly equal in physical qualities to German silver that the demand for the latter as a material for watch movements may be considered a mere matter of taste. It must be mentioned here that German silver is, to a certain degree, susceptible of magnetism, a circumstance not at all favorable in a material used for the construction of the frame of horological machines. It appears also that the threads of screws in German silver will not last as well as in brass, if due care is not taken to grease the screws a little at each repairing of the watch; this has led to the employment of coarser screws (deep cut and wide thread) for the better class of these movements.

In many nickel movements the spring hook in the barrel and even the barrel cover are of brass, a fact from which we may conclude that German silver has been found wanting in these points.

Galvano-Plastic Art.

BY EXPERT.

ARTICLES OF open work, as mentioned in my last communication, are readily made by electro deposit of exquisite beauty, both as regards design and execution. Rustic patterns of endless

variety and marvelous freedom can be produced in this way. The first step is to make the design on paper of the size intended, and the next is to transfer it to the wax panel or tablet which is to serve as a mould. A very good method to accomplish this is by means of transfer paper. As directed in a former article the wax tablet should be black, consequently our transfer paper needs be of some color which will readily show on black. For this purpose Indian red is excellent, as it covers any color more perfectly than even black. To prepare and use this transfer paper, take some fine dry Indian red and mix it with spirits of turpentine and olive oil—the proportions are as follows:

- 1 oz. fine dry Indian red.
- 3 “ spirits of turpentine.
- 1 “ olive oil.

These ingredients should be mixed by stirring in a tumbler, and after being thoroughly incorporated, about two-thirds of the mixture should be poured into another vessel; the object of this is to let the heavy and coarse particles settle to the bottom of the tumbler in which the mixture was made. This composition brushed over good English tissue paper, and the turpentine allowed to evaporate (which it will do in an hour or two), forms the transfer or tracing paper. To use it the design should be made on rather light-weight paper, and the transfer paper placed between the wax surface and the

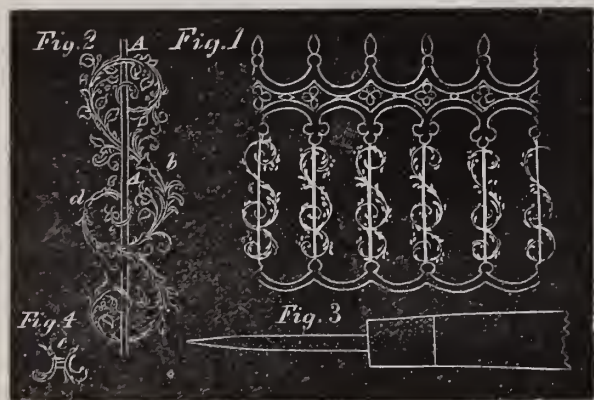

design; the side of the transfer paper having the Indian red upon it should, of course, lie next the wax. By going lightly over the outline of the design with a blunt needle, or a piece of pegwood sharpened to a point, on removing the design and transfer paper, a fine tracing will be found on the face of the wax in Indian red corresponding to every line traced over with the tracing point. Now, in this style of work—open work—like lattice or lace, we should proceed differently from the relief panels heretofore described, and go about it somewhat in accordance with the design in hand. If the design is composed of heavy and light parts combined, the method of melting and drawing up the portion of the wax made fluid, as described in a former number, can be resorted to, and the finer lines traced in with a point, or some cutting instrument. There are many ways in which effects, or rather results, can be obtained. Among these is mixing some pigment with the wax to make it crisper, so that a point like an etching point can be drawn through the surface, producing a fine, sharp line; but in such methods it must be kept in mind that wax thickened in this way does not work so cleverly when liquified and drawn up by a suction *pipette*. But the person who attempts things in this way will soon be astonished at the results which can be obtained at a trifling expense of time and labor. Broad bars of metal (produced by the melting and drawing up process), and fine lines of metal not larger than a hair, can be produced at will. At fig. 1 is shown a panel of open work more intended to give an idea of the range of work than for any useful place to which it might be applied. All the heavy parts can be produced in the wax by melting, and the finer lines traced in with an etching point. An etching point is a steel point set in handle, as shown at fig. 3. A large darning needle set in a handle with the extreme point slightly blunted will answer first rate. This point is

drawn through the wax to produce the fine lines, using a thin piece of board called a bridge, to rest the hand upon. At fig. 2 is shown one of the bars enlarged; the fine lines are etching point lines, while the leaves are produced with scrapers and points of such shape as has been described. The essential difference between such open work panels and those described in former articles, is in the treatment of the wax panel after the work of melting and sucking up, and also the tracing of the lines with the etching point and scrapers. When the work is complete, that is, every part cut as deep as desired, the whole face of the panel is polished with black-lead and a soft camel's hair stomp brush, care being taken that even the finest line is perfectly coated with black-lead (but not filled up with it). If the panel was now inserted into the sulphate of copper bath and a coating of copper cast on, we should have a flat panel of copper with our pattern slightly raised upon the face. But in this style of work, after the whole surface is black-leaded, the entire flat surface is scraped free of black-lead, leaving this substance only in the depressions; consequently every recess and line is coated and hence a conductor. A copper wire should now be melted into the wax mould, and black-lead connections established between the wire and the design. The wax tablet should now be immersed in the sulphate of copper solution and the battery connected. After a few minutes a bright deposit of copper will spread over the broader portions of the design and gradually creep along the fine lines. If some of the fine lines are not connected and the deposit does not follow, it can be made to do so by touching the face of the wax with a fine sable or camel's hair pencil dipped in (so-called) gold bronze, and brushing from some conducting line to those not filling, as shown at *c*, fig. 4. As soon as a connection is established the part touched with the bronze and now rapidly coating with copper should be stopped out with a solution of shellac in alcohol. For such deposits the battery should be intensified, as described in former papers, so as to produce a hard deposit. The work should be carefully watched, and as soon as the fine lines begin to spread and lose their sharpness, they should be stopped off by painting over with shellac and alcohol. The heavy portions should be cast strong enough to support the more delicate parts. A little care and judgment will ensure success. When the deposit is judged to be complete, it should be removed from the wax by melting. Whatever wax adheres can be got rid of by washing in benzine. The cast should be washed with an alkali to remove any grease, then dipped in weak acid and well rinsed, when it is ready for silver plating or gilding. Panels produced as described, in conjunction with hand-wrought corners and supports, can be made to produce a very graceful and elegant effect, and of a delicacy of execution that would defy any other known process. Even lace itself can be used in conjunction with articles produced by this way. The perforated paper, now so common for valentines and a thousand and one decorative purposes, can be used. The manner of proceeding is very simple. The paper or other lace is dipped in melted white wax and then put between blotting paper and pressed with a moderately hot smoothing iron, when the excess of wax will be absorbed. For those commencing such experiments the paper lace is the best, as it is more easily manipulated. Care and judgment should be exercised in regard to the quantity of wax left in the lace—if of paper only wax enough should be left to give a slight gloss, while if thread lace is used about as much wax should be left adhering as can, except to fill the meshes; and it is a decided good plan to stretch the bit of lace in hand on a wire frame, and after the blotting paper has been applied to expose it (the lace) to a heat sufficient to liquify the wax. This treatment lets the threads come out rounder, and the wax coating is every way more perfect. After the lace or paper seems to be in good condition it should be coated with black-lead and then immersed in the sulphate of copper solution, and a sufficient coat of copper deposited to give substance to the tissue when it is ready for gilding. Such pieces of lace used as panels, and, of course, supported by the frame-work of the panel, can be made very beautiful—silver mesh with gold embroidery. The heavier parts can be burnished, both of frame and lace-work.

"Traveler" Finds the Guild.

To the Editor of the *Jewelers' Circular* :

"Eureka!" I have found it at last. There is a Watchmakers' and Jewelers' National Guild, and I've just shaken hands with him. He is the identical Guild I have been chasing all over the country, and at last I have treed him in Chicago. You will remember that I wrote you some months ago that I was in pursuit of a National Guild, and that while I could hear of him in different parts of the country, I never could get near enough to put salt on his tail. Recently I was in San Antonio, Texas, and while still prosecuting my inquiries regarding a Watchmakers' and Jewelers' National Guild, I found a man who knew all about it. He told me that not only was there a Guild, but that the Guild was going to have the biggest convention in Chicago on the 9th of May that city had ever seen. He said invitations had been sent out to everybody in the trade, to the President and his Cabinet, to the crowned heads of Europe and the Sandwich Islands, and to all the American people, and everybody was going to be there. He said that arrangements had been made to bring this great crowd to the city with all the railroad and steamboat lines, express wagons, and every means of conveyance, and a special line of balloons would be run between the east and the west. The city was to be decorated and illuminated in honor of the Guild, and Chicago was to see a sight compared to which Philadelphia's best Centennial days were but sideshows.

I immediately resolved to be in attendance at this great gathering of the Guild, and so began the journey northward. I expected to find the railroads blockaded with heavy trains bearing loads of weary pilgrims to this Mecca of the jewelry trade, and was astonished when I entered Chicago without meeting any delay. I expected of course to find the hotels all crowded to overflowing, and had made up my mind to be satisfied if permitted to sleep on a billiard table or in the coal hole. Judge of my amazement when I found the hotels were not full by a large majority, but that, on the contrary, the landlords, as is their custom, were watching eagerly for solitary missionaries like myself, with a view to robbing him of an honest dollar. Not comprehending this thing, so different from what had been represented, I thought I must have mistaken the date, but in wandering about the city I encountered our old friend Shurly, who used to be head center of the Guild, according to reports, printed and otherwise, I said to him:

"Shurly, my old friend, you are just the man I want to see. Tell me, where is the National Guild?"

"Damfino," replied Shurly, sententiously.

"What!" exclaimed I, "doesn't the Guild have its grand annual centennial free-for-all-meeting here on this date?"

"Damfino," was Shurly's unintelligible remark.

"Why, I have been informed," said I, "that the Watchmakers' and Jewelers' National Guild was to assemble here at this time—can you tell me anything about it?"

"Oh!" said Shurly, "you must mean Boynton. Yes, I believe he has assembled over at the Sherman House. You go over there and ask for Boynton, and if he ain't there, ask for Kelley; they're the Guild."

"But where is the big crowd—the President and the crowned heads, and all the jewelers of the country and all the people that were to be here?" asked I.

"Tending to their little biz, I guess," said Shurly. "That crowd is all in your mind's eye, Horatio."

To say that I was sorely disappointed is to express the condition of my feelings but faintly. But if disappointed in the crowds, in the President and the crowned heads, I had at least the assurance that Boynton and Kelley were in town, and that where they were there was the Guild. Shurly informed me that as many as six other Guilds were expected in the course of the day, and when these got here there would be a quorum and they would proceed to business. I resolved to be present when the quorum arrived.

I went to the Sherman House at the hour appointed for the meeting, and there at last, after many months of weary and fruitless search, my longing eyes at last rested upon the Guild. He was sitting at the head of the room, and had just called the other fellows to order. There were five of them, including Kelley and the President and Secretary. I made inquiries about them and found they total up as follows: Boynton, President and Contractor-in-Chief of the Guild, principal orator and bloviator in general; Baker, Secretary, \$100 a year and perquisites; Hoefler, who expects the Guild to establish a horological school and give him the bossing of it; A. P. Boynton, who has a trade watch company (in his eye) and wants retail dealers to take stock in it; and Kelley, of the Rockford Silver Plate Company, who has spent eight dollars for a Guild stamp and wants his contract extended three years so he can get his money back. This is the Watchmakers' and Jewelers' National Guild. There was occasionally a resident dealer in the room during the day, and half a dozen or so out of town retailers who were passing through the city looked in for a few minutes at odd times, but the five I have named were on hand all the time, like a sore thumb.

Presently they proceeded to business. There were never more than seventeen or eighteen persons in the room at a time, but nevertheless the Guild was present and business went on. The President appointed a committee on credentials, and then adjourned to two o'clock P. M. At two o'clock the Guild was present—the immortal five—and the committee reported that said five were properly vouched for. Then the President announced that this was to be a star chamber session, and no reporters or outsiders would be permitted to listen to their momentous proceedings. Thereupon myself and the other outsiders departed. This was tough on me, after I had come all the way from Texas to attend the meeting of the Guild, to be turned out in the cold this way, but when the Guild said their business was of too secret a nature to be transacted in public, I had nothing to do but "git," and I "got." I had supposed in my veridancy that so august a body, devoted to the interests of the watchmakers and jewelers of the country, would have business of such importance to the trade to transact that they would be glad for all the world to hear and profit thereby, and that especially would they want the press to sound their grievances and herald the reforms they propose. But no! the big Guild said it must be a private session, and all the little country Guilds chirped assent, and so they resolved themselves into a star chamber committee, and their proceedings took place behind closed doors.

Next day the daily papers had an exaggerated account of the star chamber session, doubtless kindly furnished the reporters by the obliging Secretary, in which it was exaggeratedly stated that "representatives were present from eighteen states." When I read that I wondered how many proxies the Guild had in its pocket to represent all those states that were not represented by citizens thereof. There must have been at least a dozen of them. We were also kindly informed that Kelley had his contract extended for three years as he wished, making a five year term during which he has the exclusive right to make Guild-stamped goods. Boynton is alleged to have made his customary speech pitching into THE CIRCULAR, and to have roared like a veritable bull of Bashan whenever he heard THE CIRCULAR mentioned. The session concluded with an enthusiastic glorification of those Rockford capitalists who promise to put up \$150,000 to build a factory in that place for the manufacture of rolled plate jewelry, on the strength of promises made that the Guild would patronize them, and under the vain delusion that the Guild had the whole retail trade at its back. And this was the grand gathering of the retail jewelers of the country to attend the annual meeting of the Watchmakers' and Jewelers' National Guild. It reminded me of the three tailors of Tooley street, with their famous proclamation, "We, the people of England!"

I met one of the boss Guilds afterward and had a little chat with him. He said substantially: "I never felt so discouraged in this thing as now. No meetings of the state associations in Minnesota, Illinois or Indiana, no quorum in Missouri, and only twenty-two at our meeting in Iowa, with scarcely a corporal's guard here. Here am I, working in the interests of the retail dealers, and the d—d fools don't know what's for their good. That JEWELERS' CIRCULAR has knocked the wind out of us." There he was about right. THE CIRCULAR has exposed the little game of these interested schemers, and the retail dealers are no longer such "d—d fools" as the Guild expresses it, as to waste their time dancing attendance on star chamber convocations held by men who are aching to get into the wholesale jewelry business.

But I have seen the Guild. It is immense. My final glimpse revealed five of them standing up at a counter and taking an observation of the sun through the bottom of a glass. TRAVELER.
Chicago, May 12, '83.

Scientific Notes.

—Professor Palmieri has, it is said, devised a process for silvering glass by means of the reducing action of glycerine on the salts of silver, which is said to have the advantage of producing a very brilliant metallic deposit. When into an ammoniacal solution of nitrate of silver is poured, first, a little caustic potash, and then a few drops of glycerine, the reduction begins at once; and this action is accelerated if ether or alcohol be added to the mixture. A moderate heat and darkness are said to increase the brilliancy of the precipitate, and darkness also favors the adhesion to the mirror of the deposit.

—Mr. Sang, of the Royal Society, Edinburgh, asserts that it is impossible to see objects, or rather their images, inverted in the air. To make good his position he examines the conditions of density of the atmosphere necessary to produce such an effect, and he concludes that these conditions were so very unstable as to make the alleged phenomenon a physical impossibility so far as clear figures are concerned. As to the well-known recorded observation of Vince, where erect and inverted images of objects are described high up in air, the very plausible explanation is offered that what the Suffolk philosopher noted was simply the case of a vessel and its reflection in a sea so calm that sky and water appeared to form one whole, making it impossible for the time to distinguish the one from the other.

—In the new alloy of copper, iron and zinc considerable difficulty has been experienced in securing a uniform admixture of the iron. A London experimenter is said to have overcome this by his method of introducing the iron into the mixture of zinc and copper. When ordinary wrought iron is introduced into molten zinc the latter readily dissolves or absorbs the former. The exact point of saturation or the proportion dissolved or absorbed varies with the temperature at which the molten zinc is maintained during the process, and it is by carefully ascertaining and controlling this temperature that a perfectly uniform product has been obtained. The metal thus produced, and to which the name of Delta metal has been given, is stated to be as much superior to brass as phosphor-bronze is to gun metal, or as steel is to iron. It possesses great strength and toughness, and samples cast in sand give a breaking strain of twenty-two tons per square inch.

—It has long been known that the introduction of iron into alloys of copper and zinc materially alters the physical properties of the products for the better. Several attempts have been made to use iron in this connection, but hitherto without practical success. Experimentally the results have proved satisfactory, but when tried on a working scale the process has failed from a want of uniformity in the products. Among others who have directed their attention to the matter is Mr. Alexander Dick, of London, who, after careful experiment and research, has succeeded in introducing the iron into the alloy in such a way as to give good results on a practical scale. This success is obtained by previously alloying the iron in such a manner that it is combined in definite and known proportions with the zinc. When ordinary wrought iron is introduced into molten zinc the latter readily dissolves or absorbs the former. The exact point of saturation or the proportion dissolved or absorbed varies with the temperature at which the molten zinc is maintained during the process, and it is by carefully ascertaining and controlling this temperature that Mr. Dick has been able to succeed in obtaining a perfectly uniform product. The metal thus produced, and to which the name of Delta metal has been given, is stated to be as much superior to brass as phosphor-bronze is to gun metal, or as steel is to iron. It possesses great strength and toughness, and samples cast in sand give a breaking strain of 22 tons per square inch. Forged or rolled into bars it shows a tensile strength of more than 33 tons per square inch, and drawn into wire of 22 gauge it is found to stand 62 tons per square inch before breaking. It has an excellent color, is very easily worked, takes a high polish, and tarnishes less quickly than brass, and on the whole appears to be susceptible of a very wide application both for useful and ornamental purposes.

—Experiments are being made, according to the *Polytechnische Notizblatt*, in Paris with a new alloy having a white color yet containing no nickel. It is said to be very strong and malleable. It is made of copper and ferro-manganese, the proportions being varied according to the purpose to which the alloy is to be employed. An alloy of forty parts of copper and sixty parts of ferro-manganese, with a suitable quantity of some appropriate flux, produces a metal of such tenacity that it surpasses the best steel armor plates. The melted mixture is cast in blocks and is perfectly malleable. To obtain a white metal that can be rolled out in sheets, the above alloy is melted again, and 20 or 25 per cent. of zinc or white metal added, which imparts to it the desired quality. A plate of the first named alloy two inches thick was found by experiment to offer more resistance to a cannon ball than a steel armor plate of the same thickness. This new kind of "white bronze" is not to be confounded with the alloy used in this country under the same name for gravestones and monuments, and which consists principally of zinc.

—Experiments are at present being carried on in Belgium, says *Iron*, to preserve steel, and steel gun barrels in particular, by coating them thinly with copper by a process of which M. F. Weil is the inventor. Its peculiarity consists in the composition of the baths used, in which the usual and always dangerous alkaline cyanures are replaced by organic acids and glycerine. According to M. Weil, these baths require no renewal of organic elements, and can be used continuously, when they are saturated with peroxide of copper. They possess also the advantage—owing to the property inherent in organic alkaloids of dissolving the peroxide of iron, without attacking the metallic iron itself—of cleansing the steel before the commencement of the coppering process, and more perfectly than can be done mechanically. The coppering is effected by putting porous clay vessels, filled with caustic soda lye in which zinc plates have been immersed, in the basin containing the organic copper base (alkaloid) and the steel. The zinc plates are connected with the steel articles to be coated with copper by a thick copper wire. The caustic lye may be used over and over again. Should it become saturated with oxide of zinc, it is sufficient for its regeneration to treat it with sulphide of sodium, when the oxide (of zinc) will be precipitated, and a valuable by-product obtained, by which the cost of the process will be considerably reduced. The coppering process, it is said, occupies but a very short time.

—The *Moniteur de la Céramique* gives the following description of Bay's process for making the new kind of glass which is smooth on one side and rough on the other—*Craquelé Indien*. The roughened surface of the glass looks as if it was covered with cracks, and this appearance is obtained by spreading over the surface of a plate of glass a thick layer of some flux or easily fusible glass that has been made fluid or pasty and mixed with coarser pieces. The glass is then put in a muffle or an open furnace and strongly heated. As soon as this flux is melted and the glass itself becomes red hot, it is taken out of the furnace and rapidly cooled. This flux or fused glass then cracks off from the other glass which was attacked by it, leaving numerous depressions in the latter resembling scales and irregular crystalline forms, crossing and intersecting each other and producing very beautiful effects when the light falls upon it. This fusible layer is cooled as rapidly as possible, either by a current of cold air, or by carefully sprinkling with cold water. If some portions of the glass are protected from the action of the flux, the surface remains smooth there in striking contrast to the crackled portion. This can be utilized in making arabesque, letters, and other designs on a white or colored ground. A similar crackled glass is made in another way, by strewing a coarsely-grained flux on a cylinder of glass while still red hot, and then putting it back in the heating furnace until the flux melts. It is then rapidly cooled, either by sprinkling water on it or waving it back and forth. The layer of melted flux then cracks off and exposes the surface of the glass which has been corroded by it. The cylinder is then cut and spread out in the usual manner.

Workshop Notes.

POLISHING IVORY OR TORTOISE SHELL.—A polish on tortoise shell or ivory is produced by rubbing the article with oxide of tin dissolved in water or oil. Rub with a piece of flannel, and gradually work dry.

STRONG CEMENT.—Mix some finely-powdered rice with cold water, so as to form a soft paste. Add boiling water, and finally boil the mixture in a pan for one or two minutes. A strong cement is thus obtained of a white color, which can be used for many purposes.

TARNISHED GILT CLOCK BEZELS.—To remove tarnish from gilt clock bezels, dead white silver work, etc., dissolve 1 ounce of cyanide of potash in 1 quart of rain water; bottle it and label it "poison." Place the work in an earthen vessel, pour sufficient of the cyanide solution on the work to cover it, and the tarnish will disappear in five minutes. Re bottle the solution for future use.

GALVANIC GOLD BATH.—M. Rad, in *Le Monde de la Science*, gives the composition of a bath to be used at temperatures from 50° to 80° C. It consists of: Crystalline phosphate of soda, 60 parts; bisulphate of soda, 10 parts; cyanide of sodium, 1 part; chloride of gold, 2½ parts; distilled water, 1,000 parts. In order to prepare the bath the water is divided into three portions of 700, 150 and 150 respectively. The phosphate of soda is dissolved in the first lot, the chloride of gold in the second, and the other ingredients in the third. The two first portions are gradually mixed together, and the third is then slowly added. A platinum plate is used as anode.

GILDING STEEL.—Steel may be gilded by means of a solution of gold in ether. To do this a quantity of gold is dissolved in nitro muriatic acid, and then boiled until the liquid evaporates, when the residue is dissolved afresh in water, to which is added three times as much sulphuric ether. The liquid is then left in a bottle for twenty-four hours, tightly corked, after which time it will be seen to float on the surface of the water. If the steel is then dipped into it, it will become gilded immediately, and if designs have been painted on the surface of the metal with any varnish, a beautiful specimen of a steel and gilded surface is obtained. For other metals the galvanic process is employed.

ALUMINUM SILVER.—This is made by smelting together 1 part of silver with 3 or 4 parts of aluminum, and is very valuable for articles in which one of the main objects is to obtain lightness, such as the instruments used for marine observations. Octants and sextants of this alloy have been received with great favor by practical navigators. Those parts of such instruments which, if made with other metals, would weigh 4 pounds, will, when made of the above alloy, only weigh 1 pound. Mechanics like to work this alloy, as it can be turned and filed away, which is not the case with pure aluminum, it being too soft, and, as no doubt all know who have worked this interesting metal, it has the objectionable property of sticking to the file.

NICKEL DEPOSITS.—Nickel deposited by the wet way is white, with a slightly yellowish tinge, having a dull pearl, gray, dead luster. It is obtained by dissolving the nitrate of nickel in its own weight of ammonia, and diluting the whole with twenty or thirty times its volume of liquid bisulphate of soda, making about 24° Beaumé. This application is found useful when articles require to be protected against the oxidizing action of damp or salt air, sulphurous gases and weak acids. Nickel electrotypes stand the wear and tear caused by ink and press much better than the ordinary copper ones. Another bath is a solution of nitrate of nickel, without excess of acid, precipitated by cyanide of potassium, and the precipitate redissolved by more cyanide. An acid solution of nickel may be precipitated by alkalies, such as potash, soda, or ammonia; after washing the precipitate, dissolve in cyanide of potassium. A moderate battery power and nickel anodes are employed.

ARTIFICIAL PEARLS.—The following process for manufacturing artificial pearls rests on the property of logwood extract and bichromate of potash to form with gelatine a compound insoluble in water: 1. Take 1 part gelatine and 3 parts water, and dissolve with heat. 2. Dissolve with heat 1 part logwood extract in 5 parts water. Mix the two solutions, pour off the excess of water, then mix 1 part of the logwood and gelatine mixtures with 2 parts water. Agitate until it dissolves, and add 8 parts of solution one, so as to have excess of gelatine. Evaporate till small pellicles are formed, then cast in the moulds required. After one hour the casting is dipped in a bath containing 1 part bichromate of potash to 30 parts water, where it is left for five minutes. Artificial pearl of a brilliant black is thus obtained, which is hard and insoluble.

DEFECTIVE PLATING.—"What is the cause of 'stripping' after replating metal spoons?" Presuming that the bath, composed preferably of the double cyanide of silver and potassium, is in good working order, he must pay attention to the mode of preparing the articles previous to their immersion in the solution. Their surfaces must be chemically clean. First by mechanical means if necessary, then by dipping in a solution of caustic potash, to remove grease and finger marks; rinse well in water; dip in weak solution of sulphuric acid; rinse again; then dip in a solution composed of one part common salt, twenty-five of nitric acid, and a drop of sulphuric acid. The final dipping is in the quickening solution, composed of one part nitrate of mercury in one hundred of water, clarified with a little sulphuric acid; the article is to be finally washed in water. The quickening solution makes the article white; very little of this is required, as too much is the cause of stripping.

SILVERING RECIPE.—Among the several recipes given for obtaining a silvering solution, Marquand recommends the following of Mr. C. Ebermacher, which has been tested repeatedly, and was found very useful, as it gives, after a short time, lustrous silver layers on metals, and especially on brass. Care must be taken that the pieces which are dipped in the metal bath be treated before in the ordinary manner in a potash solution and dilute hydrochloric acid. The silver bath is made with a solution of 4 ounces lunar caustic (equal to a solution of 2½ ounces silver in 7½ ounces nitric acid); the silver of this solution is precipitated as oxide of silver by the addition of a solution of 2½ ounces caustic potash in 6¼ ounces distilled water; and the precipitate, after being washed, is added to a solution of 12½ ounces of cyanide of potassium in one liter of water. This solution is then filtered and water added to bring it to 4 liters. In this solution, which is heated on the water bath, the pieces to be silvered are left for a few minutes. Being agitated, they are taken out, and put to dry in fine sawdust and then polished.

CLEANSING SOILED CHAMOIS LEATHER.—Many workshops contain a dirty wash leather, which is thrown aside and wasted for want of knowing how to cleanse them. Make a solution of weak soda and warm water, rub plenty of soft soap into the leather, and allow it to remain in soak for two hours, then rub it well until quite clean. Afterward rinse it well in a weak solution composed of warm water, soda and yellow soap. It must not be rinsed in water only, for then it would be so hard, when dry, as to be unfit for use. It is the small quantity of soap left in the leather that allows the finer particles of the leather to separate and become soft like silk. After rinsing wring it well in a rough towel, and dry quickly, then pull it about, and brush it well, and it will become softer and better than most new leathers. In using a rough leather to touch up highly-polished surfaces, it is frequently observed to scratch the work; this is caused by particles of dust, and even hard rouge, that are left in the leather, and if removed by a clean brush containing rouge, it will then give the brightest and best finish, which all good workmen like to see on their work.

What the Retailers and Jobbers are Doing.

C. M. Rich has just opened an attractive jewelry store at Frankfort, N. Y.

C. H. Schiller, of Utica, will move into new quarters in Genesee street early in June.

F. N. De La Meter, formerly of Honeoye Falls, N. Y., has sold out and is visiting friends in Ohio.

D. G. Golding, of Leadville, Colorado, is reported to have sold out his jewelry interest to G. W. Bittinger.

Quite a number of retail jewelers throughout the country are resorting to the auction business in order to force sales.

The old house of Cook & Sloss, of Louisville, Ky., are settling up their firm affairs with a view of retiring from business.

W. W. Childs, of Jackson, Mich., has the reputation of being one of the most intelligent and scientific workmen in the state.

H. J. Woodside, of Portage La Prairie, Manitoba, formerly of Minnesota, is doing an excellent business in that new country.

Ringwald Bros. & Co., of Helena, Montana, keep an excellent assortment of jewelry and have a very attractive establishment.

Koch & Dreyfus, of New Orleans, carry a large and well selected stock of goods, and a line as complete as that of any jobbing house in the trade.

James H. Hart, of Brooklyn, has concluded to open a retail establishment in Maiden Lane, in the store formerly occupied by the late firm of Sillcocks & Cooley.

Savage & Lyman, of Montreal, are doing an excellent business. This is an old and reliable firm and has the confidence of a large number of firms in this city.

Thomas Kirkpatrick, of this city, has moved into more commodious quarters, corner of 22d street and Broadway, which have been fitted up in a neat and attractive manner.

Webb & Hall, of Janesville, Wis., are doing an extensive jobbing business. They are wide awake, enterprising men and enjoy the confidence of a large clientage of friends.

C. W. Little, of Denver, Col., conducts a strictly jobbing business. He carries a large and varied stock of goods and his business is rapidly developing to one of great magnitude.

A. J. Warner & Co., of Minneapolis, are doing a very satisfactory jobbing business. They are enterprising, pushing business men and their success is as deserving as it is great.

T. G. Calvert, of Lexington, Ky., is putting up a Howard Clock in the St. Paul's Catholic Church of that city. The clock is made to strike the hours and quarters on a peal of bells.

Burdick & Otero, of Pueblo, Colorado, are doing a large business in the manufacture of filigree jewelry, for which there is quite a demand among the Mexican population in that section.

Morrison's gold and silver solutions for electro-plating without a battery have become celebrated in the trade, and are indispensable for watchmakers and jewelers. They are for sale by the principal jobbing houses.

M. S. Smith & Co., of Detroit, will have, when finished, the handsomest jewelry store in the west. The interior decorations will be fitted in Honduras mahogany, under the direction of B. & W. B. Smith of New York.

Stephen Thomas, Jr. & Bro., of Charleston, have ordered a Marvin's burglar proof safe. It will be remembered that this house was robbed some time since by expert burglars, who converted their old safe into mince meat.

C. A. Estburg, of Waukesha, Wis., is a gentleman well known and highly esteemed in the community in which he lives. He has a very attractive jewelry establishment, and is regarded as a straight, square man in all his dealings.

M. T. Graham has disposed of his branch establishment at Birmingham, Ala., to Thomas Brady, formerly of Franklin, Ohio. Mr. Graham will hereafter devote his attention exclusively to the jobbing business at Nashville, Tenn.

P. Gottesleben, of Denver, Col., is a gentleman whose fine artistic taste is recognized in the trade. He is probably as well informed in art matters as anyone in the country. He keeps a choice stock of goods and has a large and growing trade.

Goddard & Moses, of Richmond, Va., are the most enterprising dealers in that section. They have a fine store, well stocked with attractive and pleasing goods, while Mr. Goddard has the reputation of being an excellent and painstaking workman.

Otto Wettstein, of Rochelle, Ills., is probably one of the best read and most intelligent thinkers on philosophical subjects in the trade. He has a large and growing business, and his store is made doubly attractive by his well selected stock of merchandise.

J. M. Chandler & Co., of Cleveland, call attention to their new patent band bracelet recently introduced by them. These bracelets can be adjusted to any size wrist without affecting the security of the catch. They are very neat and attractive goods and are having a good sale.

The retail jewelers of Florida have done an extensive business during the past winter in curiosities peculiar to that state, such as alligator teeth jewelry, stuffed birds, Florida beans, etc. The number of visitors to that salubrious climate during the winter created a demand for these specialties.

Lapp & Flershem, of Chicago, have just published a very complete catalogue and price list of watchmakers' tools, materials and specialties in their line, for the use and convenience of those in the trade. It is intelligently arranged and neatly printed, and embraces every article required by the practical workmen in the trade.

Robinson Bros., of Toronto, one of the old reliable houses of Canada, carry a full and complete line of fancy goods, and all articles calculated to enhance the attractiveness of a jewelry store. Mr. Robinson, the founder of the firm, is a man of much enterprise and unswerving integrity, and his sons, who have succeeded him in business, possess the same characteristics.

Dickinson & Hopkins have bought out the interest of F. S. Murray in his jewelry business at Bay City, Mich. The new firm is composed of enterprising and practical men, who have opened with an excellent stock of goods. Mr. Dickinson was formerly of Havana, New York, and Mr. Hopkins has been for two years in the employ of Hennegen, Bates & Co., of Baltimore.

James H. Bell, of Tarboro, N. C., is an enterprising jeweler and an excellent workman. He has recently fitted up his store in a neat and attractive manner, and branched out with a new stock of watches, jewelry, clocks, musical instruments, etc., etc., in fact every kindred article that will tend to make his store more attractive to purchasers and consequently more profitable to himself.

James Fricker, of Danville, Va., is a man who knows how to run a jewelry store, being not only an excellent workman but a good merchant. He carries a diversified stock of goods, and from time to time publishes interesting articles in leaflet form for general circulation, their purpose being to educate the public to a better appreciation of the better classes of goods. These leaflets are not only popular, but are excellent advertisements for Mr. Fricker.

Bowman & Musser, of Lancaster, Pa., who established themselves in the jobbing business a year or two ago, adhere strictly to a jobbing business with the legitimate retail trade, and refuse to sell to outside dealers under any circumstances. Mr. Bowman is well known in the trade, and enjoys in a high degree the respect of the community in which he lives, while Mr. Musser has been associated with him for many years in business and was recently admitted to the firm.

Trade Gossip.

The boom in wedding rings continues.

Tiny silver pistols are the latest agony in lace pins.

Beer kegs of oxidized silver are used for perfumery.

Day & Clark have removed from 192 Broadway to 10 Maiden Lane.

B. S. Kalish, of Bangor, Me., has failed, with liabilities amounting to \$11,000.

Bracelets of chased silver mice, their tails forming connecting links is the latest.

It is the manufacturing jeweler who is posted on the beauties of silver service reform.

Small fans to represent one-half of a hen, with the feet for the handle, are fashionable.

Welch & Miller have removed from room 9 to room No. 29 of building No. 169 Broadway.

Influenza is all the rage, and smelling salts are worn at the girdle, suspended by a silver chain.

S. E. Fisher & Co. and R. F. Simmons & Co. occupy convenient offices at No. 41 Maiden Lane.

The firm of John Frick & Co. has been dissolved by mutual consent. John Frick will continue the business.

The recent admission of forty new applicants to membership in the League swells the total number of members to 2,580.

Jacot & Son is the name of a new firm about to establish itself in Maiden Lane as importers of watches and musical boxes.

J. D. Smith's jewelry store, at Union City, Ind., was destroyed by fire on the night of the 5th ult. Loss estimated at \$15,000.

The growing popularity of open-faced watches is not confined to this country, but extends throughout Europe and Australia.

J. W. Ruth's jewelry store at Shelbyville, Tenn., was recently destroyed by fire. Loss variously estimated from \$2,000 to \$4,000.

The MacKinnon Pen Co have removed from 192 Broadway to 18 John street. Hereafter all orders will be supplied by Leroy W. Fairchild.

George Southwick, for several years with Messrs. A. Bernhard & Co. as traveler, is now in the employ of J. F. Angel & Co. in a similar capacity.

It is rumored that quite a number of diamonds have recently been smuggled into this port, and the Custom House officers are on the hot scent of them.

H. Muhr's Sons have taken the office formerly occupied by Leopold Weil & Co., No. 14 Maiden Lane, and are fitting it up in a neat and attractive manner.

It is reported that some of the up-town jewelers are to occupy offices in Booth's Theatre building that is now being remodeled for commercial purposes.

The New Haven Clock Co. have removed from No. 62 Reade street to Nos. 16 and 18 Park Place, where they have greater facilities for transacting business.

Seventy manufacturers of watches and jewelry will exhibit their products at the Zurich exposition, which was opened May 1, and will continue through September.

The firm of Harris & Spier has been dissolved by mutual consent, with a view of retiring from business. A. Harris will collect all the outstanding accounts and pay all the firm's indebtedness.

The latest agony in scarf pins is one having a small head, and is inserted diagonally in the scarf, so that it looks as though it had been out on a spree all night and hadn't got round to its right place.

The old house of Magnin, Guédin & Co., for many years occupying a leading position in this city, has gone out of business. A large portion of their stock was recently sold at auction to close the business.

George Agassiz and family, of St. Imier, will spend the summer in this country. Mr. Agassiz is a relative of the late eminent scientist of that name, and also the manufacturer of the celebrated Agassiz watch.

C. G. Alford, of C. G. Alford & Co., has, by the advice of his physician, gone into the Adirondacks for health and recreation. He has always been a hard worker, and his close application to business was beginning to tell on his health.

The "keeper of the crown jewels" lives in the Tower, and gets \$1,500 a year for doing nothing. The difference between that chap and the average office holder is that the latter does not live in a tower, and generally gets a bigger salary.

Mr. E. W. Clark, of Tallahassee, Fla., has in his possession a clock presented by the first Napoleon to Prince Murat while the latter was residing in Tallahassee. On the face is engraved the following: "Le Roy Hr. des A. I. S. et R. Madame mere des M. l'Empereur."

A lady in Washington owns the wedding-vest buttons and knee-buckles of "Light-Horse Harry" Lee. They are made of opals, surmounted with diamonds. She also has a piece of his watch chain, which he broke one evening while waltzing with her grandmother.

Henry May, importer of watches and diamonds, No. 19 John street, is having quite a run on the Melville stem winder, put up in hunting cases of coin silver, in sizes designed especially for boys and gentlemen. These goods will be sent to any responsible house on approval.

Some of the boys in the Lane are having lots of fun with their friends with some of the painted diamonds regarding which so much has been said of late. These practical jokes always result in an adjournment of the entire party to the peaceful abode of the genial Stewart in John street.

There is a person visiting different places and obtaining goods, principally diamonds, on memorandum, by representing himself to be David Keiser, a well-known traveler for L. Strasburger & Co. The trade is cautioned against this individual, and are requested to communicate with Mr. Keiser should he attempt to obtain any more goods in his name.

Ladies' handkerchiefs are embroidered with mottoes suitable for the mood of the day, such as, "I am cross, don't speak to me;" "What a lovely day;" "I don't care for company," etc. The dudes are following suit with scarf-pin emblems, as, "I will pay you next week," "Don't care if I do," "Damfino," "Lend me a quarter," "See you later," etc.

At a meeting of the New York Jewelers' Club, held May 8, a communication was received from the New England Manufacturing Jewelers' Association, inviting the New York Club to participate in a re-union to be held in Providence, July 6. The invitation was accepted, and on motion the matter of arrangements was placed in the hands of the Executive Committee.

The Travelers' Protective Association of Ohio will hold their first annual meeting at Sandusky, June 9. The election of officers for the ensuing year and other business of great importance will be brought before the association, and all members are requested to be present. A banquet and ball will be given on Friday, June 8, and an excursion to Put-in-Bay on Saturday, June 9.

The Howard Clock Co. have just built for the New Orleans Cotton Exchange a very fine quarter-striking clock, with bells weighing 4,000 and 1,500 pounds each, and dial measuring six feet in diameter. The clock also controls the dial in the board room and strikes the gongs to regulate deliveries of the board. This company has also built a fine striking clock for the City Hall, Atlanta, with four illuminated dials measuring nine and one-half feet, and a bell weighing 2,000 pounds.

The many friends of Oscar L. Ballard, a well-known jeweler at Malone, N. Y., will be pained to hear of his sudden death by drowning. A few days ago, while out sailing on Meacham Lake, the boat suddenly capsized, drowning both him and his nephew, who was with him at the time. The deceased was a very popular man in the community in which he lived, and well known in the jewelry trade in this city. He leaves a wife and two daughters, who have the sincere sympathy of all who knew the husband and father.

William Dudley, of Canisteo, N. Y., was recently robbed by a gang of strolling burglars. His loss amounts to \$5,000, the goods stolen consisting of watches and jewelry. Some time elapsed before the detectives could be notified, but finally the thieves were traced to Williamsport, where they were lost. This is one of the many illustrations of the necessity for such an organization as is proposed in the Jewelers' Alliance. Retail dealers should not neglect to avail themselves of such protection as is offered by the Alliance.

The Syracuse *Herald* is responsible for the following statement: A pine floor laid in a gold worker's shop in ten years becomes worth \$150 per foot. A Syracuse jeweler once bought, for less than \$50, some sweepings that gave \$208 worth of gold. A tub in his cellar, into which is blown the dust from a polishing lathe, accumulates \$50 a year. A workman in his shop carried off on the tip of his moistened finger \$30 of filings in a few weeks. Workmen sometimes oil their hair and then run their fingers through it, leaving a deposit of gold particles, which they afterward wash out.

Joseph F. Stokes, a clerk in the Naval office at Philadelphia, has confessed to being the guilty party who gave out copies of invoices received by one jobber to a competitor. Detectives brought the matter home to Stokes, who finally made a confession, after having previously asserted his innocence. The copied invoices were those of H. Muhr's Sons, and these gentlemen have magnanimously written a letter to the Secretary of the Treasury asking that Stokes' offence be overlooked this time. The diligence displayed by this firm in detecting the irregularities of the Philadelphia Naval Officers entitles them to much credit.

The following named members of the trade sailed for Europe during the past month: L. Kahn, of L. & M. Kahn, in the *Fulda*; Henry Zimmern in the *Servia*; P. A. Leimbach in the *Fulda*; Emanuel Wendel, of Chicago, sailed on the 15th; Paul Jeanne, of Jeanne Bros, in the *Normandie*; Edward Holbrook, of the Gorham Manufacturing Co., A. G. Lewis, of G. C. Shreve & Co., and F. Bemis, of Bigelow, Kennard & Co., in the *Celtic*; M. Oppenheimer, of the firm of Falkenau, Oppenheimer & Co., in the *Normandie*; B. Boehme, of Boehme & Swigert, of Toledo, in the *Fulda*; Jules Racine in the *Normandie*.

Since the death of the late J. T. Scott, some busybodies and unprincipled persons have circulated the story that the business he established was to be discontinued. This is a gross fabrication, for the sons of Mr. Scott will still conduct the business. They are trained business men, having been brought up by their father with a view to succeeding him, and the same energy and enterprise that characterized his transactions, will be displayed in future by the sons. They are well known to the trade as young men of marked ability, who will prove worthy successors to a father who was respected by all who knew him.

In the May issue of THE CIRCULAR an item appeared setting forth that C. W. Little, of Denver, Col., had been robbed by sneak thieves of diamonds valued at \$13,000. The amount was intended to be stated at \$1,300, but the printer put in an extra cipher, and so converted hundreds into thousands. The value of the goods actually stolen, was, we understand, \$1,250. We regret that a typographical error of this nature should have crept into our columns, but accidents will happen in the best regulated families. Immediately on discovering the error, we took measures to inform the trade of the exact facts in the case, and to thus do justice to Mr. Little. Mr. Little is one of the most enterprising dealers in his state, and even had the loss been equal to the larger sum it would in no way have affected his standing, as his ample capital is sufficient to cover such a loss without seriously inconveniencing him.

The Jewelers' Security Alliance, announced in the May number of THE CIRCULAR, is now in full working order. Its purpose is to afford protection to retail dealers from the depredations of the gangs of burglars that are known to be wandering about the country with special designs on jewelry stocks. Already they have perpetrated numerous robberies, and the fact that they have in most instances escaped prosecution, has made them particularly bold and audacious. It is the purpose of the Alliance to aid all its members in recovering any goods that may be appropriated by burglars, and in bringing them to justice. Enforcing rigorously the penalties provided by law is regarded as the best means of putting an end to burglaries. The Alliance will assist any of its members, who may be robbed, in this good work, by procuring the assistance of expert detectives and by sharing the expense. Retail dealers in all sections of the country have written letters approving of the plan, and it is hoped that dealers in general will avail themselves of the protection it offers. It costs but \$10 membership fee and \$5 each year for dues, while the advantages it offers may be regarded almost in the light of insurance upon stock. Applications for membership may be addressed to H. W. Hiller, P. O. Box 3277, New York City. Over one hundred applications have been received, and certificates of membership will be forwarded as speedily as they can be printed.

At the annual assay of the coins of the United States, held by the Assay Commissioners in February last, it was found that some of the old coins issued from the New Orleans Mint, in January, 1882, contained 898.93 of gold, being seven one-hundredths of one-thousandth below the limit, and a greater deviation from the legal standard than is allowed by law. This fact was certified to the President, who referred the matter to the Secretary of the Treasury. Mr. Snowden, Superintendent of the Philadelphia Mint, was subsequently detailed to go to New Orleans to investigate the matter and ascertain the cause of the deficiency and to report who was responsible for it. His report, which has just been submitted to the Secretary of the Treasury, places the responsibility upon the Assayer of the New Orleans Mint. All the papers in the case will be submitted to the President for his action.

"It costs a good deal of money to keep a fashionable dog nowadays," said a clerk in an up-town store where all sorts of fancy articles are sold. "Extremely fashionable women are following the French very closely in the elaborateness of outfits for their pets. Until a couple of years ago all that any woman ever thought of putting on her dog was a collar of more or less elegance. We had collars of every sort in stock, from plain leather or metal bands to richly ornamented and expensive work. Clasp collars with family monograms or crests in gold were made to order. About the time that bangles were being made from coins we made a number of dog collars of gold and silver pieces. Russia leather and alligator leather reigned for a while. These collars usually had gold-bound edges. But the dog shows of late years have created a craze among women for all sorts of ornaments for their dogs. You see, one woman would have a cocker spaniel or an Italian greyhound on exhibition in a velvet cage, and this would at once set all the other women who visited the show crazy over velvet cages. Another woman would have a jeweled collar on her dog, and all the women wanted jeweled collars at once. The fashion of blanketing pups spread like wildfire at the dog show. All the best designs were copied. Now there are are richly embroidered lap rugs and fur wraps for the dogs when they taken out for a drive. These robes usually have a monogram or crest worked in the center. The latest thing, however, is the dog bracelet." The clerk exhibited a number of little bracelets of gold and silver. They are made to fit the left leg of dogs, and most of them are much smaller than finger rings. Three of these rings were ornamented with diamonds. They are fastened on with miniature padlocks.

As this is the season of the year when members of the jewelry trade are looking about for rural and sequestered places to send their wives and families into retirement during the hot weather, we are constrained to publish the following lines, evidently the result of a quickening conscience of one who has "been thar," in the hope that it will be the means of saving some of our friends from the indiscretions indicated:

Of all the insidious
Temptations invidious,
Contrived by the devil for pulling men down,
There's none more delusive,
Seductive, abusive,
Than the snare to a man with a wife out of town.

He feels such a delightfulness,
Stay-out-all-night-fulness,
Shall-I-get-tight?-fulness—
I own it with pain!—
A bachelor rakishness,
What-will-you-take?-ishness,
Next-day's-headache-ishness,
None can explain!

His wife may be beautiful,
Tender and dutiful—
'Tis not that
her absence should cause him delight,
But the cursed opportunity,
Baleful immunity,
Scatters his scruples as day scatters night.

With a take-every-trick-ishness,
Full-as-a-tick-ishness,
I'll-be-a-brick-ishness,
Though conscience frown;
With a forth-let-us-steal-someness,
Kick-up-our-heels-someness,
There's a wife of the de'il-someness,
In a wile out of town.



THE JEWELERS' CIRCULAR AND HOROLOGICAL REVIEW

The recognized organ of the Trade, and the official representative of the Jewelers' League.

A Monthly Journal devoted to the interests of Watchmakers, Jewelers, Silversmiths, Electro-plate Manufacturers, and those engaged in the kindred branches of art industry.

SUBSCRIPTION:

To All Parts of the United States and Canada,
\$2.00 Per Annum; Postage paid.

To Great Britain, France, Switzerland, Germany, the West Indies, Mexico, the Republics of South America, and Australia, \$3.00 per annum. Postage paid.

All communications should be addressed to D. H. HOPKINSON, 42 Nassau Street, New York. Advertising rates made known on application.

Some Grievances of the Jobbers.

IN RECENT issues of THE CIRCULAR we endeavored to point out some of the principal difficulties that beset the path of the retail dealers, and to show how the persistency of manufacturers of cheap goods in selling to outsiders is rapidly diverting the retail trade from its legitimate channels and throwing it into the hands of the proprietors of fancy bazaars, dry goods stores, notion dealers, gents' furnishing goods establishments, etc. Already this practice has sadly demoralized the retail dealers, and they, like ourselves, are at a loss to suggest a remedy. This class of manufacturers insist that they find their profit in ignoring what has been the rule of the trade for many years, and that so long as it pays them to sell to outsiders they will do it. But the retail dealers are not the only sufferers from this illegitimate practice. The jobbers are feeling its effects quite seriously, for many of these outsiders have become extensive jobbers within the past few years, and are now supplying goods by wholesale to all sorts of merchants in all parts of the country. It is not long since the retail dealers were condemning the jobbers for sending out price lists and catalogues promiscuously and offering to sell at retail at wholesale prices to every Tom, Dick or Harry that wanted to buy, and now the jobbers complain that the manufacturers are doing precisely the same thing, and thereby robbing them of trade that should belong to them. If the chickens of the jobbers are thus coming home to roost, and the law of compensation is to be maintained, how are the manufacturers to receive their punishment for their illegitimate practices? That is something for the future to determine, but it may be taken for granted that the laws of commerce, established by long usage and dearly bought experience, cannot be set aside with impunity or the offender hope long to escape punishment. These recognized laws have heretofore required that the manufacturers, jobbers and retailers should be recognized as three distinct classes in the jewelry trade, each dependent upon the

others, and each being protected by the others. Without mutual protection come disorder and demoralization, and those terms about express the condition of the trade to-day; manufacturers are selling at jobbers' prices to outsiders, and jobbers are retailing at wholesale prices, while between the upper and the nether stones the poor retail dealer is threatened with being ground into dust or forced out of the business.

Just now the jobbers are loud in their complaints against the manufacturers. They are expected to carry the goods of the manufacturers for the convenience of the retail dealers; to ask short credit for themselves, but to extend long credit to the retail dealers, who are not usually in a condition to pay cash, but more often need long time and a helping hand. The jobber must, therefore, have considerable capital of his own to meet the demands of the two extremes of the trade, the one clamoring for cash payments, and the other for more time in which to meet his obligations. Thus placed, the jobber claims that he is entitled to the hearty co-operation of the manufacturers in protecting his trade, instead of which he finds them, with malice aforethought, deliberately cutting his throat by selling to outsiders and giving them every advantage in prices that he enjoys and that should belong exclusively to him. According to their statements, it often occurs that a salesman for these manufacturers of cheap goods will visit the jobbers, and, by his persuasive eloquence, stock them up to overflowing with his goods, and then go to the retail dealers and to the dry goods merchants and other outsiders and stock them up with a line of precisely the same goods at jobbers' prices. The jobber thus finds the market he had depended upon overstocked, as does the retail dealer also. He is in a quandry, and, as a means of self-preservation, is forced to work up a retail trade in order to dispose of his goods. In order to do this he must come into competition with the regular retail dealers as well as the outsiders, and the result is a cutting of prices that whittles down the margin of profits so exceedingly fine that it becomes almost invisible. Some of the travelers for a certain class of cheap goods houses are wholly unscrupulous in their dealings, and will sell their goods by the single piece or by the quantity to anyone who will buy at the lowest price they would sell to a jobber. They have been known even to decorate the chambermaids at the hotels with their cheap goods and take an order on the landlord in payment, which order they would subsequently turn over in payment of their board. In the larger cities these travelers have a more extended field of operations, and run from the jobber to the retailer, and from him to the outsider with their goods with the greatest alacrity, stocking each up to the fullest extent his seductive tongue can persuade them to buy. They do not restrict themselves always to "one price" for their goods, but make their figures to suit their customers, so that it not unfrequently occurs that an outside dealer has obtained his goods for a less price than the legitimate jobber has paid for the same line. If the outsider is a more liberal buyer than the jobber he is pretty sure to have every advantage the traveler can give him. It is but a short time since that a jobber bought a quantity of cheap but

attractive goods from a traveler for a Providence house, with the express purpose of disposing of them to those great bazaars controlled by keen, pushing, enterprising merchants, where jewelry is kept as a special attraction. The jobber, having laid in a liberal stock, hastened to market it. His chagrin can be imagined when he discovered that these places were already stocked up with the same goods, the enterprising traveler having sold to the outsiders before even visiting the regular trade. Inquiry also developed the fact that these outsiders, by buying for cash, had paid less for their goods than the jobber had. The language used by the jobber on this occasion cannot be printed in ordinary type. But this was merely a case of diamond cut diamond—the jobber had hoped to sell to the outsiders and thus injure the retail dealers, only to find that the manufacturers' traveler had got ahead of him, and killed both the jobber and the retailer with the same stone. A case of this kind does not draw upon us for a very great amount of sympathy, but it serves to indicate the way the tide is setting. The manufacturers excuse themselves for this double dealing by saying that they simply supply the demand for their goods, and it is immaterial to them through what channel the demand comes, so long as it brings the cash with it. They also allege that they are but following the example of the jobbers, whose efforts to steal the retail trade aroused such vigorous protests from the retail dealers a short time since, and led to the organization of various associations to stop the evil. Whatever motives prompt this class of manufacturers to these illegitimate practices, certain it is that they are gradually breaking down all barriers that time and experience have interposed between the three distinct branches of the trade, and instead of seeking the regular channels for the disposal of their goods, are inviting a free-to-all scramble for them, in which the entire populace is welcome to participate. What the end of this unbusinesslike method of disposing of goods will be it is impossible to predict, but it is safe to say that it can only result in disaster to those engaged in it. The indications are that the intense rivalry that characterizes the business of these outsiders will lead to such a cutting of prices that even the manufacturers of cheap jewelry will be slaughtered and left without even a symptom of a profit. Then when they once more turn to seek the regular avenues of legitimate trade, they will find that the demoralization they fostered and encouraged has done its work, and that what has been known as the regular trade is known no more. All this will not happen immediately, but as the seed placed in the ground fructifies, grows apace, blossoms and bears fruit, so surely will the evil practices now being sown return a harvest of disaster unless a stop be put to them.

But the jobbers do not intend to sit quietly by and see their business stolen away from them in any such disreputable manner. Their protests have been of no avail thus far, and a movement is on foot having for its object the formation of an association to compel manufacturers to respect their rights. It is proposed that members shall pledge themselves not to buy any goods of a manufacturer who sells to retail dealers or to outsiders, and it will be the duty of the association to find out who are doing this and keep the members informed. Such an association, if it embraced but one-half the jobbers of the country, would serve as a powerful check upon the illegitimate practices we have referred to, provided its members observed good faith among themselves. But while the association of jobbers is watching the manufacturers, who will watch the jobbers? The retail dealers need protection quite as much as the jobbers, and now that their state associations have been diverted from their original purpose, and have become simply a medium for the glorification of a few individuals who have personal axes to grind, there is no watchman at the gate to observe the movements of the jobbers. There has been something of a return this season to the catalogue and price list nuisance so freely indulged in a few years ago by certain jobbers, and these are again putting forth their efforts, but more cautiously, to capture the retail trade. There are grievances on all sides to be redressed, and it is the duty of every honorable dealer, be he manu-

facturer, jobber or retailer, to do his best to right them. The trade in general has widely departed from the traditions and practices of its fathers, and thus far no good has come of it. It is a good thing to stop occasionally and see what the trouble is and where it lies, and if by calling attention to facts as they exist we shall be instrumental in bringing forth a better order of things, our purpose will have been accomplished.

IN ANOTHER column we print a communication signed "T," from an enthusiastic believer in state associations of retail dealers. He agrees with us, that outsiders have become exceedingly formidable competitors for the retail trade, and thinks that because of this the associations should be strengthened to the end that they may drive out the outsiders. The time when this was possible has passed. When we first saw the tendency of the trade towards outsiders some years ago, we pointed out the danger, and suggested as a remedy National laws fixing the quality of wrought gold, and providing penalties for misrepresentation of quality. It was the production of cheap and fraudulent goods that first tempted the outsiders into competition with the retail dealers. The state associations, however, instead of acting upon our suggestion, or developing some feasible plan of their own, were led off by some visionaries into adopting an abortion called the Guild stamp, which is no protection to dealers whatever, and in no wise curtails the production of cheap or fraudulent goods. A government certificate of value accompanying all goods would have enabled retail dealers to hold their trade, for outsiders would have no temptation to compete for it, and if they had they would not be audacious enough to meet them on equal terms in their own line of business. But in cheap goods they saw a chance for large profits, and from handling these, many of them became dealers in the finer grades, until now it is a question which buys the most goods of all kinds, the regular retail dealers or the outsiders. The associations failed to grasp the situation, and now the time has passed when a government interference would be available, or when it is possible for them to cut off these outsiders. Instead of taking the aggressive in the first instance and closing the door against their intrusion, they have permitted the outsiders to so firmly entrench themselves in competition that they cannot be dislodged. It is now the retail trade that is on the defensive, and instead of holding the fort, it is in full retreat before this army of outsiders, and it is a question if even the baggage train can be saved. The state associations proved entirely unequal to the emergency for the lack of intelligent and disinterested leaders, and their days of usefulness have passed. They may well be relegated to that oblivion where rightfully belong incompetency and inefficiency. They never commanded the support and countenance of the more intelligent and most numerous portion of the retail trade, and their membership has so dwindled away that it has been scarcely possible for any of them to get a quorum together this year for an annual meeting. To attempt to galvanize them into life again would be as hopeless a task as would the attempt to extract a Fourth of July oration from the Egyptian sphinx.

Our correspondent "don't take much stock" in our suggestion that the proper way for retail dealers to meet this outside competition is to diversify their stocks, keep goods that are attractive of whatever kind, and supply the public with what it wants. He says, first, that retail dealers have not the capital to make additions of other kinds of goods to their stock. With most retail dealers, their credit is their capital, and if their credit is sufficient to enable them to buy jewelry, it is sufficient to enable them to buy goods of almost any other description. Jobbers in other lines are not much more exacting than are jobbers in the jewelry trade. If a retailer has an established business and a good business reputation, he can get credit for all the goods he needs to enable him to compete as a merchant with his neighbors. Secondly, our correspondent alleges

that because all dry goods men, for instance, do not sell jewelry, it would be unfair towards those who do not, for retail jewelers to sell dry goods. This is an absurd excuse, for, if some dry goods men do not deal in jewelry, it is because they find something else pays them better, not because they have any scruples in the matter. There are very few dry goods or other merchants who confine themselves exclusively to one line of goods—they are merchants, and deal in that which pays them best, and do not hesitate to diversify their stocks, if not with dry goods, then with boots and shoes, groceries, or whatever the public wants. There need be no compunctions of conscience in this matter, for the retail trade of this country in all its branches, is to-day controlled by merchants, not specialists, and merchants cater to the public demand, be it for dry goods, jewelry, butter and eggs, or hardware. Retail jewelers must become merchants in the fullest sense of the word if they expect to control their share of public patronage. They have not been invested with a monopoly of the trade in jewelry, but whoever wants to earn a living has a right to enter into competition with them, precisely as they have the right to compete in any other line of business. This is a rushing, bustling, pushing, busy army of humanity that is struggling for an existence, and he who does not keep up with it is sure to go under.

SO MANY retail jewelers have been robbed of late the creditor class is naturally feeling considerable anxiety as to the means retail dealers provide for the safe keeping of their goods. Men who buy goods largely on credit have a double reason for guarding them securely, for they have not only their own interest in them to protect, but that of their creditors also. When a retail dealer is robbed of his goods, his creditors are usually called upon to stand a part of the loss, as the retailer generally is forced to compromise his indebtedness. Therefore the creditor class, whose goods are found in nearly every retail store in the country, hears, with that degree of anxiety that is born of pecuniary interest, of the numerous robberies that are occurring, and asks if there is not some way to circumvent the robbers. To this end they have instituted the Alliance, to which we made special reference in our May and June issues, which is designed to be an organization of retail dealers that shall employ detectives to investigate every robbery perpetrated on a member, and bring the thieves to justice, the expense of so doing being borne by the Alliance. But this is in the nature of locking the stable door after the horse has been stolen—a pursuit of the thief with a view to the recovery of the property and his punishment. Prevention is better than cure, and if the retail dealers will provide themselves with due safeguards for the protection of their property, the Alliance will have little to do, a condition of things that will be most pleasing to all concerned. The first essential to prevent robbery is a good, substantial, burglar-proof safe. As a rule, the retail trade is but poorly provided in this respect. Dealers are too apt to put confidence in almost anything resembling a safe, regarding it more as a protection from fire than from thieves. But burglars have grown expert in their work, and possess tools of superior excellence, and if given an hour or two, will readily force their way to the interior of an ordinary safe. The common, cheap safe, intended to resist fire, offers but a slight obstacle to their skill; the thin, outside shell of iron is easily bored through, and the inner lining offers slight resistance. Safes are made, however, especially to resist attacks of burglars, and have been frequently found to offer so much resistance as to utterly baffle the depredators. Time with them is a matter of great importance, and every moment they are delayed in their work increases the chances of their detection. It is well known that many retail dealers have, from motives of economy, bought cheap, second-hand safes, whose days of usefulness had long since departed; they offer little more resistance to an expert burglar than would a wooden chest; some of them are so old that a few blows of a sledge hammer would burst a hole in them, or break bolts and leave the contents to the

mercy of the thieves. Yet retail dealers will trust exclusively to such rickety concerns for the safety of thousands of dollars worth of goods. Every retail dealer should be supplied with a good, solid, burglar-proof safe, and into this should be placed every night all his choice and valuable goods. This duty should not be intrusted to the office boy, but the master himself should attend to it and see that the safe is securely locked, a duty a subordinate often neglects. Safes are by no means perfectly constructed, but good ones will do much to thwart the schemes of the criminal classes, and the dealer who has taken the precaution to provide one will, in case of loss, meet with much more sympathy in the trade than he would if he had trusted his goods to a tin box or a cheap, insecure safe. No other class of goods presents such inducements to thieves as jewelry, for the reason that great values can be put up in small packages and easily removed, and are also readily converted into money, great desiderata to thieves. With better safes and more watchfulness among retail dealers, there would be fewer robberies, and fewer retail dealers asking their creditors to pay part of the penalty of their negligence.

THE CUSTOMS officers on the other side of the Canadian line cannot be very vigilant, for smuggling goes on to a great extent under their very noses. We are in receipt constantly of complaints from Canadian jewelers to the effect that it has become almost impossible for them to compete legitimately with the smuggled goods that are to be found in their market. They cannot pay duties on the goods they buy here and sell them at a profit, when the same goods are delivered there at prices that are acknowledgment that they have not paid duties. Smuggled goods reach Canada generally by way of Detroit, Buffalo or Suspension Bridge. The smugglers come here and buy what they want at jobbers' prices; being in the jobbing business somewhere, our manufacturers sell them without any suspicion that the goods are destined for Canada by the underground route. Having his goods, the smuggler goes to the frontier cities and sends them across the border by means which long use has proved to him are sufficient to elude the customs officers. In the Canadian cities there are plenty of buyers of these goods, who pay cash for them on delivery, and are, of course, enabled to undersell the honest dealers who pay duties on their goods. We are informed that this kind of smuggling is very seriously affecting the legitimate trade; unless means are taken to prevent it, all the dealers in Canada will eventually have to depend on the smugglers or go out of business. So bold have the smugglers become in consequence of the immunity they enjoy that, we are informed, they solicit orders from the Canadian dealers, agreeing to deliver the goods within a certain time free of duty. This indicates a remarkable degree of laxity among the customs officials. It ought to be a dangerous experiment to attempt to smuggle goods across the border, and the capture and punishment of a few who are engaged in the business would put an end to it. Certainly the legitimate dealers cannot bear up against such competition, and will either have to buy smuggled goods as a matter of self-preservation or give up entirely.

ANNOUNCEMENT is made that an immense land slide occurred early in April at the famous Kimberley diamond mines of South Africa, burying several of the workings with a great depth of earth, rocks and debris, and also destroying much of the machinery in use. It is estimated that the work of removing the rubbish and opening again the "blue ground" in which the diamonds are found, will take at least a year, and cost the several companies working the mines not less than \$1,000,000. Immediately upon the receipt of this news in England diamonds advanced in price thirty-five per cent., and have continued to advance steadily ever since. There will necessarily be a great scarcity in the market for a long time to come, as

these mines furnished the greater portion to the trade. A corresponding advance in prices has been made in this country, and diamonds bid fair to be exceedingly scarce as well as high-priced, for some time to come. The effect upon the market here cannot but prove serious, for the demand in this country for diamonds has been so great for the past few years that dealers have with difficulty filled their orders, so that the supply will naturally fall short of the demand. Diamonds just now are the best goods in the trade, and the dealer or jobber who has a stock on hand is indeed fortunate. He will be entirely justified in advancing his prices materially, and will then find it difficult to replace them. Importers now abroad report that it is almost impossible to obtain diamonds suitable for this market, Americans being the most critical buyers in the world and demanding the finest gems.

WE HAVE heretofore announced the formation of the Jewelers' Alliance, which is designed for the protection of retail jewelers from the depredations of thieves and burglars. The plan is simply that the Alliance will aid its members in recovering any goods that may be stolen, and in bringing the thieves to justice. So many robberies have occurred lately that mutual protection of the nature proposed has become a necessity. It is bad enough for a retail dealer to be robbed, with a certainty that positive loss to him must result therefrom, but it is adding a heavy burden to his cares to know that all the expense and trouble of hunting the thieves must be borne by him. The Scriptural injunction to "bear ye one another's burdens" has special application in these instances, and a burden that might crush an individual is lightly borne when shared by many. Since the Alliance was organized, many retailers have sent in their names for membership, and we hope to see all the dealers of the country enrolled in a short time. While the dull season that has now settled down upon the trade holds out, it is a good time for retail dealers to take the matter into consideration. No one enjoys immunity from robbery, and when the store is cleaned out, then is the time that earnest and hearty co-operation becomes acceptable. This the Alliance proposes to give. To obtain the full benefits offered by the Alliance, dealers should send in their names at once.

Standard Time.

A ST. LOUIS man who professes to carry "railroad time" must have five watches about him, for trains going out of that city are run according to five different standards of time. A Buffalo man who should make the same claim could get along with four watches, and so could a Cincinnati, an Indianapolis, a Kansas City or an Omaha man. Three watches would be a sufficient outfit for a New London, Memphis, Louisville or Augusta, Ga., man who should profess to carry the railroad time of the place. If some enthusiast should attempt to carry the railroad time of the country he would have to struggle under the weight of fifty-five timepieces, for there are fifty-five standards of time in use by the railroads.

The standard adopted by a railroad is usually the local time of some important point along its line. There is one exception—a road which, in answer to a request for information, reports that its standard of time is "the Superintendent's watch." A man going west through Buffalo by one of the routes from that city learns from the time table that the train with which he hopes to connect leaves Buffalo six minutes before he is due there, and when he arrives in that city he learns by comparison of standards of time that he has half an hour to wait for the outgoing train. A man with Jefferson City time in his pocket and bound for the Pacific coast would carry railroad time till he reached El Paso, but there he would have to turn his watch back a couple of hours, in order to carry railroad time when the train started on. Going from St. Paul toward the

Pacific, he would have to set his watch back fifteen minutes at Fargo, again at Bismarck, again at Glendive, again at Billings, and several other times before he reached the coast, if the road were built clear through.

If these differences of time are puzzling and sometimes annoying to travelers, they are far more puzzling and annoying to the men who have to make up the time tables for railroads and arrange them so that trains on different roads shall make connections. In the General Time Convention of railroad men, held in this city in the fall of 1881, the question of greatly reducing the number of standards of time in use on the roads—a question which had already been discussed a good deal—was referred to the Secretary of the Convention, Mr. W. F. Allen, of this city. In a Convention held in St. Louis on April 11 last, Mr. Allen made his report, submitting a plan which met with the approval of the Convention so far that it instructed him to send copies of the report and accompanying maps to all general managers and superintendents, and to endeavor to secure their acquiescence in the adoption of the plan. At the Southern Railway Time Convention in this city a few days ago, the plan of Mr. Allen was unanimously adopted, and the opinion was expressed that the new arrangement would undoubtedly go into effect in the coming fall.

Mr. Allen's plan makes five standards of railway time for the entire railroad system of the United States and the eastern British provinces. The difference of time between standards is one hour; thus, when it is noon in the Provincial division it is 11 o'clock in the Eastern, 10 o'clock in the Central, 9 o'clock in the Mountain, and 8 o'clock in the Pacific. The time of the Eastern division varies but 4 minutes from New York City time. The greatest difference between the local time and the proposed railway standard time at any important point is about 35 minutes. The lines separating the five divisions are as nearly north and south lines as regard for the advisability of changing time at terminal points will permit. The Provincial standard is to govern the running of roads in Canada east of Quebec and the other British provinces; the Eastern, roads in the New England and Middle States, Virginia, West Virginia, and North and South Carolina; the Central, roads in the other southern Atlantic and Gulf States and the Western States to a line drawn from north to southwest of the Missouri river; the Mountain, roads between the western boundary of the Central and a line touching Missoula, Salt Lake and Fort Yuma; and the Pacific, all roads to the west of that line. Each time division extends from the northern to the southern limit of the railway system of the country.

Smuggling by Mail.

"YOU will be surprised to hear of the curious assortment of dutiable articles that we intercept in the steamship mails from foreign Post Offices," said Mr. William Freeman, who, with Mr. J. M. Wilson, has charge of the Customs Bureau in the Post Office. "The Post is a favorite medium with persons in Great Britain, France, Germany, and other countries for shipping presents to friends in the United States. The senders probably do not think of the duties to be paid when they forward their packages, but under the customs laws and regulations presents of merchantable value are classed as dutiable, like goods imported in the regular way. Tradesmen in London, Paris, Berlin, and other European capitals use the mails pretty regularly to send samples and goods of small bulk to American customers.

"Ladies find an easy, cheap and safe way of putting into letters and newspapers articles of fashion, knick-knacks and mementoes from the Old World. The mails are also used for intentional smuggling, but it is sometimes difficult to distinguish between smuggling and legitimate importations. Diamonds, watches, and precious stones and jewelry of all kinds are intercepted by the bureau. The

supposed dutiable packages and letters are detained, and the persons to whom they are addressed are notified to appear and open them in the presence of the officers. Not long ago a package which was opened by a Maiden Lane diamond dealer was found to contain several thousand dollars worth of uncut diamonds. He paid \$800 on them at the Custom House. There were also received packages of cat's-eyes, rubies, cameos, intaglios, emeralds and sapphires sufficient to stock a good sized jewelry store."

"Some of the queer mailable matter of dutiable value received includes jars of home-made German pickles, meerschaum pipes, bundles of cigarettes, packages of garden seeds, ladies' silk vests, surgical instruments, large-sized paintings on tin from Italy, pedometers for pedestrians, hair nets, a German cheese, architects' tools, fancy mats, mushrooms from France, picture frames, druggists' chemicals, shawls and valentines."

"What class of goods constitute the bulk of the mail importations?"

"Books. They come in large quantities, and the greater part of the duties is collected on them. Authors, clergymen, and other professional men are numbered among the consignees. The duty is twenty five per cent. of the value. Books for educational institutions are admitted free where copies of the articles of incorporation are filed with the bureau. Books for addresses outside of New York are forwarded to the Postmasters with a printed form stating the amount of duties due, and the Postmaster is requested to collect them and remit to the Collector of Customs."

"Can you tell me some of the devices for sending goods through the mails?"

"Laces, kid gloves, silk stockings, silk handkerchiefs, and other light articles are enclosed in newspapers and pamphlets. They are enclosed so that it is hard to detect them. A pair of silver sardine tongs going to California was recently found hidden in a package of pamphlets. In an English newspaper were discovered lady's silk stockings, one black and one red. According to the revenue law, these might be taken as samples and entered free. A trick was suspected, and the articles were detained. The next steamer's mail contained a newspaper addressed to the same person. In it were folded one red and one black silk stocking to match the others. The lady to whom they were addressed was sent for and paid the duty.

"Old bibles and books are used to send watches and other jewelry, the leaves being cut and spaces hollowed out to hold the smuggled articles. One book, arranged in this way, disclosed, on being opened, three gold bracelets, two watch chains, two locket, a set of sleeve buttons, five gold pins and two necklaces. This collection was on its way to a lady in Cincinnati. It was appraised at \$334. One mail will bring the first part of a book and the next mail the rest of it; but this trick for getting books in free is rarely successful. About the holidays the mails are heavily burdened with dutiable goods. The advantages of putting goods through the Post Office over the regular way of importing, is that no brokerage, warehouse, cartage or entry fees are required.

Novel Method of Stealing Diamonds.

PHILADELPHIA detective is responsible for the following description of a novel method resorted to by thieves for stealing diamonds. A man and woman, who usually assume the role of husband and wife. The pair drive up in a carriage before the jewelry shop they have selected, and, alighting, enter the door. The man always appears very aged and infirm, and leans heavily on the woman's arm for support. A pair of crutches even heighten the effect. Reaching the diamond counter, the old man seats himself. He is too weak to stand. His arms are evidently partially paralyzed, and hang limp by his side. He asks to see some loose diamonds. The clerk holds the tray very close to the man's eyes because his

eyesight is so poor. Having no use of his arms and hands, the clerk even takes up a gem that he can truthfully commend and shows it to the prospective purchaser. The tray is set before the old man, but the clerk's eyes are riveted upon the gems of course. Several paper packages of the brilliants are opened. Clearly the old man is selecting a memorial present. Ultimately several packages are spread out on the tray, perhaps 100 or more diamonds. The near-sightedness of the poor old man increases. He leans even further over, and, with his face close to the gems, gazes fixedly at them. Just at this juncture the woman, with an estatic exclamation, points to some prominent article in an adjacent case on the wall behind the clerk. Instinctively the eye of the salesman follows the direction indicated. One instant is enough. The thief's tongue meanwhile has been thrust into one of the open parcels of diamonds, and as quickly withdrawn into his mouth with three or four gems adhering to it. The theft can only be detected by weighing the parcel or counting the gems. This is rarely resorted to, as no suspicion is excited. The next move on the part of the thieves is to select a couple of gems and order them set; or to order them sent C. O. D. to any address in a respectable locality that occurs to their minds. Then they enter their carriage and drive away.

The Jewelers' League.

President, G. T. WOGLON.....Of Woglom & Miller.
First Vice-President, JAMES P. SNOW.....Of G. & S. Owen & Co.
Second Vice-President, HENRY HAVES.....Of Wheeler, Parsons & Hayes.
Third Vice-President, WM. C. KIMBALL.....Of H. F. Barrows & Co.
Fourth Vice-President, AUG. KURTZBORN.....Of L. Bauman Jewelry Co.
Secretary and Treasurer, WM. L. SEXTON.....Of Sexton & Cole.

EXECUTIVE COMMITTEE.

ROBERT A. JOHNSON.....Of Colby & Johnson.
 JOHN D. LYON.....Of Lyon & Hardy.
 JOSEPH B. BOWDEN.....Of J. B. Bowden & Co.
 JAMES D. YERRINGTON.....Of J. D. Yerrington & Co.
 SAMUEL W. SAXTON.....Of Saxton, Smith & Co.
 C. B. BISHOP.....Of Carrow, Bishop & Co.

EXAMINING FINANCE COMMITTEE.

CHAS. G. LEWIS.....Of Randel, Barmore & Billings.
 C. G. ALFORD.....Of C. G. Alford & Co.
 G. R. HOWE.....Of Carter, Sloan & Co.

THE JEWELERS' CIRCULAR is the *exclusive* official paper of the Jewelers' League, and has been selected for the publication of all matters of interest pertaining thereto. Letters or inquiries pertinent to its business or purposes, and which might interest the trade or inquirers, will herein be answered. Address *Jewelers' League, Box 3,444, P. O., New York*, or the office of THE CIRCULAR.

The regular meeting of the Executive Committee of the Jewelers' League was held June 1. There was no special business to engross their attention, for which the perspiring members were duly thankful. The affairs of the League are now in such excellent condition, thanks to the tact and executive ability of the officers, that they run effectively and smoothly without friction. During the season when the trade in general is taking its recreation, the Executive Committee has comparatively little to do, but when cooler weather comes, they have to make up for it by giving their time daily to its affairs.

At the recent meeting the following named persons were admitted to membership:

D. C. Buvinger, E. Francis, T. Mundorff, J. Mundorff, A. Krailsheimer, A. Krower, D. W. Lapham, C. Lucacs, R. H. Roberts, New York City; T. Fazakerly, Jr., Albany, N. Y.; F. Hammond, Buffalo, N. Y.; A. Herzberg, J. Herzberg, M. R. MacDowell, Philadelphia, Pa.; T. G. Wagner, Braddock, Pa.; R. B. Freeman, Blossbury, Pa.; W. T. McBurney, Sandy Lake, Pa.; S. L. Joseph, J. C. Mann, J. C. F. Ternandt, Chicago, Ill.; A. F. Baab, C. J. Cook, Newark, N. J.; F. E. Scholle, Bayonne, N. J.; D. S. Cooke, A. S. Southwick, Providence, R. I.; M. R. Hammatt, Boston, Mass.; J. C. Perry, Springfield, Mass.; G. B. Warren, Taunton, Mass.; G. H. Adams, Wrentham, Mass.; E. B. Eustis, G. B. Eustis, C. D. White, Minneapolis, Minn.; L. C. Lowes, Indianapolis, Ind.; F. St. Amour, St. Albans, Vt.; E. H. Carpenter, Burlington, Iowa; W. H. Saxton, New London,

Conn.; A. W. Myer, San Francisco, Cal.; W. Hazeltine, Kokomo, Ind.; P. Tindolph, Vincennes, Ind.; E. L. Coombs, Houston, Tex.; S. D. Mills, T. J. Turner, Kansas City, Mo.

Ten applications were referred for correction or investigation. One application was rejected.

Total membership at date, 2,621.

Amount in Benefit Fund, \$4,972.30.

Amount in General Fund, \$3,471.87.

Proceedings of the Horological Club.

A DISTINGUISHED BODY OF WATCH AND CLOCK MAKERS.

One hundred and ninth Discussion.—Communicated by the Secretary.

[NOTICE.—Correspondents should write all letters intended for the Club separate from any other business matters, and headed "Secretary of the Horological Club." Direct the envelope to D. H. Hopkinson, Esq. Write only on one side of the paper, state the points briefly, mail as early as possible, as it must be received here not later than the eighth day of the month, in order to be discussed and reported in the CIRCULAR for the next month.

GRINDING CASE SPRINGS ON AN EMERY WHEEL.

Secretary of Horological Club:

I have one question I would like to ask your honorable body. I have noticed for some time that if a case spring be fitted to a case by grinding on an emery wheel, that the spring will break every time. I have broken as many as a dozen springs at one time trying to fit one to a case. I will add here that fitting springs by grinding them is a very easy and quick way to fit a spring, and, if it was not for the matter of breaking, it would be much superior to using the file.

W. S. H.

Mr. McFuzee thought that if the emery wheel was carefully used, and employed only for rough shaping, and afterward smooth filed and polished as usual, to get out all the scratches and cuts from the emery wheel, then hardened and tempered, there would be no difficulty about the breaking of these springs, any more than of those on which no emery wheel had been used. But he would not advise to grind off a spring already hardened and tempered, as the wrenching and jarring of the hard metal, and the innumerable cuts left in the surface by the emery, were very likely to promote fracture of the spring when bent.

WHY CUT BALANCES ARE USED.

Secretary of Horological Club:

Can you inform me why cut balances are taking the place of all solid gold, steel and nickel, in the cheap grade of watches, as the Club some time ago informed us that cheap cut balances would run wild, and were not reliable?

JERRY.

Mr. Clerkenwell replied that the principal reason for using cut balances in the very cheap movements was, that the public thought a watch with a cut balance was a much better timepiece than one with a plain balance—and, of course, dealers are ready to take advantage of this impression, and handle such goods as sell best. As for "running wild," what was said was, that an expansion balance, when cut and tested, may be found to act pretty well, or may be very much out. Of course it can be adjusted to good performance by altering the positions or weights of the screws, but that is too tedious a job to be undertaken except upon extra balances for fine movements. Out of a lot made precisely alike, a few will be so nearly correct as to require but a few touches, the rest will be more and more out, and the poorest will run "wild." The different qualities are then put into different grades of movements. "Jerry" will find the whole subject fully explained in Excelsior's book, "Practical Treatise on the Balance Spring, and the Adjustments of Watches and Chronometers for Isochronism, Positions, Heat and Cold," etc., published at the office of THE CIRCULAR. He will then understand why the fact of containing a cut balance is no guarantee of a movement keeping good time, as such a balance, if not adjusted, may run "wild" and be worth less than a solid balance.

BROKEN MAINSPRINGS—RETAIL DEALERS' PROTECTIVE UNION.

Secretary of Horological Club:

I was pleased to see the article on mainspring broken in 32 pieces, because my former plan for cleaning mainsprings was to remove the cover and arbor, and then immerse the barrel and spring in a solution of sulphuric ether, after which the spring was removed from the barrel and carefully and thoroughly wiped. But I have long since abandoned that plan, for I am convinced that chemically cleaning mainsprings is a very fruitful cause of their breaking. I was also very glad to note the proposition of a protective union for retail dealers in last month's issue. I am certain that there are enough (at least) who would embark in the scheme to make it a perfect success, and we certainly stand in need of some more perfect safeguards than we now possess, and those that are beyond the reach of the majority of retailers.

W. S. C.

ELLIOTT'S AUTOMATIC WATCH OILER.

Mr. Uhrmacher then exhibited a new watch oiler which had been sent to him by G. H. Richards, Jr., of Boston. This oiler is made on a principle somewhat similar to that of the stylographic pen. It consists of a handsome nicked handle, made hollow, and acting as a reservoir of oil. The point was also hollow, with a taper wire filling the hole, and pressed forward by a spiral spring. This wire normally projects a little, but when pressed back into the point of the oiler it delivers a small quantity of oil at the spot on which the wire is pressed. He did not know the price, but thought it would prove a very handy oiler to use.

HOW TO DRILL A BALANCE STAFF FOR PIVOTING.

Secretary of Horological Club:

Reading over my bound volumes of THE JEWELERS' CIRCULAR—which, by the way, make a valuable book of reference—I frequently notice the query, or words to the same effect, what is the *best* way of drilling a balance staff for pivoting? and in nearly every instance directions are given how to soften the staff without injuring the balance. Now I think that the best way is *not* to soften the staff at all, and thus avoid all risk of injuring the balance. I do as much pivoting as falls to the lot of the average watchmaker, and I very rarely ever draw the temper of either a staff or pinion. As regards the form and manner of making of my drills, I refer the Club to a little pamphlet published by the J. G. Hall Mfg. Co., of Roxbury, Vt., in which they give full directions for making drills.* I make them in the same way, with the exception that those made especially for pivoting are very short in the blade, the proportion being: Make the blade about once and a half as long as the pivot to be inserted; also instead of drawing the temper, I leave it hard. When hardening I heat it to a cherry red and plunge in mercury. A drill made and hardened in this way will drill any staff. Of course it is very brittle, and must be used with care; but keep it sharp, so that a light pressure will make it cut. Do not let it become clogged in the hole by chips, to twist it off, and, as brittle as it is, it will last a long time and do good service. When pivoting the lower end of a staff, of course the drill has to conform to the size of the staff, but with the upper end I usually turn off the stump and shoulder, down to the part that carries the hairspring collet. By doing this a larger drill can be used, and it also makes a better job, as then the short upper staff with its pivot are of one piece. To many the above method of working will not be new; to others it may be the means of helping across a hard place—I give it for what it may be worth. If you think fit, publish it; if not, the waste basket stands handy.

L.

Mr. Ruby Pin said that Mr. L.'s method was good and worth following. But mercury is not a very nice thing to have around a watch bench, or even in the shop, especially if there are any careless hands or boys around to tip it over. And as regards making the drill one and a half times as long as the diameter of the pivot, that was allowable when the staff is so extremely hard as to make it very difficult to drill. But whenever practicable, he thought it better to drill two or two and a half times the thickness of the pivot, as it is far more likely to stay in its place and remain firm. We shall be pleased to hear from Mr. L. again, and also from any others who can give us items of information useful to the trade.

* It is mailed free of charge to anyone applying. The directions are too long to copy here.

CURIOUS ELECTRICAL PHENOMENON.

Secretary of Horological Club:

Will Mr. Electrode kindly explain the following phenomenon.

C.

'Our attention has been called to a very singular phenomenon connected with the residence of Mrs. D. S. Sigler. The house itself is one of the finest and most commodious in southwest Iowa, having cost \$25,000, and has every modern convenience attached to it. The roof is composed of slate, the structure of brick. It is warmed by a Paige heater and lighted by gas. It will be remembered by our readers that Mrs. Sigler had been quite sick for the past six weeks. It was during one of the visits of the family physician, Dr. Newell, of this city, in attempting to give his patient medicine from a spoon, that sparks of fire were emitted. This led to a further examination, and a finger pointed at or near the chandeliers would produce the same result; in short, it was discovered that the entire house, in all parts, was a complete galvanic or electric battery. The effect was felt in all the rooms, and the same result could be accomplished upon the person of any one.

"It is explained upon no known scientific principle as yet, but is supposed to be caused by the generation of electricity through the heating apparatus, which extends from the basements to all parts of the house. It is supposed that this electric condition of affairs has in a great measure contributed to the prostration of Mrs. Sigler, and measures will be taken at once to have a scientific examination made of the difficulty, and if found in the supposed heating apparatus, the same will be removed and steam substituted. There is certainly nothing in the location of the property that produces such a result; unless it be that the house is situated upon some kind of a bed of metal or iron ore."

Mr. Electrode said it was useless to attempt an explanation without knowing something of the circumstances. Descriptions are always so distorted and exaggerated that little dependence can be put upon them unless made by someone who understands something of electricity. The writer of that item did not, for a galvanic current would not give off sparks in the manner stated. Nor would a current from a powerful dynamo-electric machine do it, because there would be no tendency to complete the circuit in such a way. Moreover, if everything was properly arranged for enabling it to give sparks as described, it would be bad for the person who received the sparks. He would retire permanently from the sparking business after one trial.

The phenomenon is undoubtedly due to what is termed static or frictional electricity, such as is produced by the ordinary revolving glass electric machine. It is well known that a very dry atmosphere is favorable to the development of free electricity, and possibly this heating apparatus gives off a current of warm, dry air, filling the house, in which case sweeping the carpets, dusting the furniture, and like rubbing operations, might develop sufficient electricity to produce sparks between an object thus electrified and another not so charged. This, however, is merely speculating about a phenomenon of which we have no trustworthy knowledge. In any event, admitting that the house is electrically charged as stated, it is certain that that would have no injurious effect whatever upon the lady's health. Its action would be more beneficial than otherwise. But if, as supposed, the heater gives out hot *dry* air, more or less contaminated with carbonic acid and carbonic oxide gases, as some of the best heaters may do if improperly worked, we have a cause sufficient to prostrate not merely a delicate woman, but even a strong man. The speaker once worked in a store with a hot air heater so imperfect in that respect, that he was thrown into a violent sick-headache every morning, when he began work, continuing more dead than alive as long as he remained. Although considered a healthy, robust man, he was obliged to give up the position, being unable to endure the gases from the furnace. In all probability, Mrs. Sigler's illness may be ascribed to a similar cause, rather than to any electrical conditions.

SOLDER FOR BRITANNIA—\$5 ELECTRIC LIGHTER.

Secretary of Horological Club:

Will a member of Club please give me a receipt for making an easy flowing solder for britannia ware? Inclosed find a circular advertising an electric light. I have heard of parties being "bilked" by sending for \$5 electric lights, and do not like the idea of losing \$5 and leaving a "bilk" find it. Will one of the members please tell me if this is a bilk or not, if they know? Also, what will a good electric light outfit cost, one for lighting a large store room, and what make do you think best?

E. B. B.

Mr. Electrode replied that there are a number of good solders for use on britannia ware. But in using any solder great care is required to avoid applying too high a heat, as that would melt the metal, or crinkle it, no matter what solder was used. Probably as safe a solder as any for ordinary use is made by melting together 1 part (by weight) of lead, 1 part of tin, and 1/2 part of bismuth. Then cut up into small pieces convenient for use.

As regards the \$5 electric lighter, he had not seen them, but was informed that it was not an electric lamp, but a "lighter," as called in the circular, such as are used in saloons, etc. to light cigars with. The platinum spiral gives out considerable light, but not suitable for regular use as a lamp. Probably those who thought they were "bilked" thought they were getting an electric lamp, whereas it was only advertised as a "lighter."

As regards the cost of a good electric light outfit, it is hardly practicable to state it. Where an electric light company is in operation, the lamp and connections are generally put in without charge. Otherwise Mr. D. would have to buy a dynamo-electric machine and all the fittings, costing at least \$300, and generally \$500, or more. He can also rig up a lot of voltaic batteries to furnish the electricity, for perhaps \$100 for the outfit, but in most cases two or three times that amount will be called for if it is kept up long. And in every case, without exception, it had better be left unattempted unless the experimenter has sufficient practical knowledge of batteries, lamps, and electricity generally, to know precisely what he wants to do and how to do it—or can afford to employ a man who does.

HOW TO TREAT A MAGNETIZED WATCH.

Secretary of Horological Club:

I have an open face gold English lever watch which, on examination, I find to be slightly magnetized. I clean a pivot with pith and touch it to steel filings, and find more or less of the filings adhere to the pivot. I notice the same with the chain. I notice, in running the watch, that it seems to take a good motion when started, but I find it out of time in carrying; sometimes it will be right for one or two days, then it may be an hour or more out when consulted again. If your honorable body can give me any instructions how to proceed to get it right, or the cost if I should have to send it to N. Y., you will very greatly oblige

J. F. D.

Mr. Horologer said it was difficult to tell, from the description given of the action of the watch, whether the cause was in the slight magnetism of the steel parts, or some merely mechanical imperfection. A magnetized watch usually acts more uniformly. That is to say, if the magnetism is sufficient to stop the watch, it stops continually, on the slightest provocation, or refuses to go at all. If merely enough to prevent it keeping good time, then it cannot be depended on at all. When a watch keeps good time for a while, then gets out, as described by our correspondent, it is most probable that it is not in good order, and it should be thoroughly overhauled to discover the defect. It is quite possible, however, although not probable, that magnetism might produce the same action. For example, some strongly magnetized parts might come more closely together at certain times, or more close to the lever fork, and attract its end so powerfully as to interfere with its freedom of motion. Again, the watch might be just able to go, normally, and a little more obstruction thrown in by some magnetized piece might stop it, or cause very irregular running. If magnetized, the quickest and best course is to send it by express to Mathey Bros. & Mathez, 16 Maiden Lane, New York, who have a demagnetizing machine, which completely frees every steel part, in both movement and case, from magnetism. The charge is usually three to five dollars, or even more for fine watches.

But if Mr. D. is so situated that he wishes to undertake it himself, he will find full description of a way to demagnetize a watch while together and in the case, in THE JEWELERS' CIRCULAR, early in 1880, with illustrations. There were also some explanations on the nature of magnetism, the philosophy of the process, etc., in the preceding numbers of 1879.

The simplest method of all, and capable of being followed by any one who has a straight bar magnet, is to take each piece of steel by itself, and pass the end of the magnet lengthways along it till the magnetism is removed. For instance, take a pinion or spring, hold it horizontally on the bench, and pass one end of the magnet along it, from one end to the other. The magnet should be held vertically, with the end nearest the pinion about an inch away from it, and kept vertical while moving it. Then present the largest end of the pinion to the north pole of the needle of a pocket compass. If it attracts the needle more strongly than before, the other end of the magnet should be used. If less strongly, continue the process with the same end of the magnet, but hold further away as the magnetism becomes weaker, else the pinion will be magnetized in the opposite direction. Always move the magnet over the piece in the same direction, and take it away when bringing it around to the starting place again. When the pinion attracts the needle with the same force, whichever end is presented to it, the magnetism is practically removed. If it attracts the north pole at one time, and the next time repels it, its magnetism has been reversed in the interval, and the other pole of the magnet must be used, and held further away, otherwise you will not only remove its magnetism but will also *remagnetize* it in the opposite direction—and you would never get through in that way. This is a slow and tedious process, but it is simple and easy, and with care and patience the work can be very well done. Of course, every precaution should be used to prevent the magnet or any magnetized tools from touching the parts afterwards, or your work will all have to be done over again.

Galvano-Plastic Art.

BY EXPERT.

A USEFUL application of the electro deposit is the production of clock and chronometer dials by the electrotype process. In fact, any engraved plate which has to be duplicated a number of times can be readily and cheaply produced in this way. It may not be out of place here to say that, in quantities, copper can be cast in this way for sixty or seventy cents per pound, and *dynamo-electric* machines driven by water-power would even reduce this estimate. To fully explain the manner of producing a clock dial in this way, we are first to suppose we engrave one, every way as we wish it, sparing no pains to make it perfect. The engraving can be done on any metal we wish, copper, zinc, or the white metal such as music is engraved upon. When the dial is complete, it should be coated with some substance to prevent the deposited copper from welding to the engraved plate; this can be done in several ways: by smearing the face with olive or some other oil, wiping off the excess with a cloth, leaving only the surface slightly greasy; another method is to brush the surface with black lead and a stiff hard brush until shining with the peculiar leaden hue of black lead. If a metallic plate is exposed to iodine vapor it soon becomes coated with a yellow film; a plate so coated, receives the copper deposit equally as well as if the plate was clean and bright, and the electro deposit cleans readily off. The deposit on the face of the engraved dial can be continued until of a sufficient thickness that when removed it can be used as a mould to cast *fac-similes* of the original dial upon. I suppose it is hardly necessary to tell the reader about rendering the backs of first the engraved dial, and then the electrotype cast non-conductive by some resinous varnish, like shellac dissolved in alcohol, or gutta-percha dissolved in sulphuret of carbon. The use of the

coating or film formed by iodine vapor on a metallic plate has several advantages, among these are: the coating does not destroy or diminish the polish or fill the finest line; and it enables us to deposit a thick coating of silver, *first*, on the face of our first electrotype or mould for subsequent dials. The reader will readily see the importance of this. Suppose we should cast on our mould (*i. e.*, one electrotype copy) a deposit, say $\frac{1}{8}$ of an inch thick, this on removal (by slightly tapping and scraping) will be an exact copy of the original engraved dial, even to scratches made by 000 emery paper; in fact, if the original dial is highly polished the copy will also have a polished face. Such a dial would not be serviceable without silvering; and silver plating with a battery would necessitate burnishing, and consequently the fine finish of the surface would be injured. There are several ways in which electro-deposit dials can be finished white; among these are first cold silvering; this is done by dissolving silver in nitric acid and precipitating the silver with common salt. The precipitated silver (*chloride of silver*) should be washed by pouring on water and allowing the chloride to settle, when the water should be poured off, repeating the washing three or four times, using four or five times as much water as the acid for solution. The dried precipitate (it should be dried in the dark) is to be mixed with four parts of cream tartar and one part of common whiting. This composition is to be rubbed on the dial with a bit of rag or a worn out brush moistened in water. This gives the pale silver coating seen on chronometer dials and thermometer scale plates. The second method is to deposit a slight coat of silver with the battery from a cyanide solution, to which is added some sulphuret of carbon; this mixture producing a bright coating instead of the dull, dead white of the usual deposit. The best method of preparing a *bright solution* is to put an ounce of sulphuret of carbon into a 6 oz. bottle, and adding 4 or 5 ounces of common strong silver solution, when it should stand three or four days. A little of this mixture, added to the ordinary cyanide solution of silver, gives the bright deposit—looking as if it had been scratch-brushed. The last and best method is to first deposit silver on the face of the electrotype mould; such a deposit can be made of sufficient thickness to stand repeated cleanings, and as it is made directly on the face of the mould, it makes no odds about the thickness of the silver coat, as it in no way deteriorates from the smoothness or sharpness of the dial or its engraving. After a sufficient deposit of silver is made it can be backed up by casting on copper to stiffen it. This method, if properly carried out, produces a dial in every way resembling a solid silver one, highly finished and engraved. Such plates are not only applicable for dials, but many other uses will suggest themselves. Another useful application of electro-deposit of copper is the process of electrotypes from movable type. Say the form of a card is set up and we wish to get an electrotype copy, so we can print from it and save the bother of resetting our type. This is very easily done; a com-

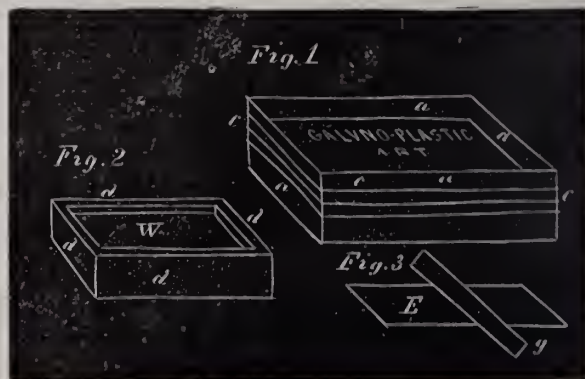

position of white wax and fine (sifted) white lead; one pound of wax and one ounce of white lead. The white lead should be added after the wax is melted; after cooling it should be remelted three or four times. Wax moulds from type or woodcuts can be made in two ways; first, the surface of the type should be brushed with olive oil, allowing the oil to fill in between the type, but keeping the upper or

face only slightly coated; a band of paper should be put around the type, as shown at fig. 1, *a a a*, representing the paper band, and *c c* the binding twine. The composition wax above spoken of should be melted and kept stirred until it begins to thicken, when it should be poured on to the type, and the paper band will allow the wax to be about $\frac{1}{4}$ of an inch thick. As soon as the wax sets the paper band *a*, fig. 1, should be removed and the type set aside until perfectly cool, when the wax mould will readily lift off. The second method (and best) is to provide a metal frame about $\frac{1}{2}$ of an inch deep; fill this with the composition of wax and white lead to within about $\frac{1}{8}$ of an inch of the top; allow the wax to cool until it is quite firm (indent easily with the nail); when the type or wood-cut (after the surface is thoroughly black-leaded) should be pressed firmly and evenly into the wax. A letter-copying press answers splendidly; in absence of such a press a very little ingenuity will find a substitute. It is not difficult to press in by hand any small form. The cut pressed into fig. 2 should also stand until cool, when the type or cut will come easily out; indeed, it can immediately be removed if care is taken not to mar, by bending over the wax edges formed in the cast. After cooling and black-leading, this mould is ready to go into the electrotype bath. The writer hopes it is unnecessary, after all the instructions given in these articles, to speak about keeping the margin clean and definite, and keeping the deposit limited to the proper surfaces. A deposit should be made of about $\frac{1}{3}$ of an inch thick, when it can be removed from the mould and mounted on a bit of board type high. If the cast should need support it can be filled in on the back with plaster paris and the excess scraped off with a straight edge of metal, (old brass rule does well,) as shown in fig. 3, *E* representing the electrotype and *g* the brass rule.

Advice to Watchmakers' Apprentices.

BY A MAN WHO HAS SPENT TWENTY YEARS AT THE BENCH.

WE GAVE the details last month of a punching press; in the present article we propose to give a few additional hints and instructions, and then consider the principal features involved in gold working, for the benefit of those who are not conveniently situated for an advantageous division of labor. Many articles produced by dies are of such shape and form that they cannot be formed at one act or process of stamping. There have been various devices resorted to to reduce this double handling and punching to one operation, and in some instances it has been accomplished; but for all ordinary purposes it is best to submit to the additional labor of re-handling and re-punching. The usual method adopted for re-punching is to set the dies for producing the article so as to cut or punch

already described; the great and almost, as we might say, only difference lies in the punched out piece being set or located by a guide shaped to facilitate the putting rapidly into position the piece to be re-punched. This will be better understood by reference to fig. 2, which shows a plan of the lower or female die for producing the openings *a a*. The piece shown at *f* is supposed to be fastened by the screws *e e* to the die bed *F*, *i i* being steady pins. This guide-piece is made of sheet metal with one-half cut away, as shown. The piece to be re-punched is pushed in the direction of the arrow *h* until it strikes the piece *f*, when, if in the position of the dotted lines, it must be right for the action of the male or upper punch shown at fig. 3 and diagram *D**. This upper die can be of one piece, slotted, as shown at *s*, or the upper die can be mortised for two pieces. For such a die as the one under consideration, one piece cut, as shown, would be the best. Diagram *D** is a view of the upper die seen in the direction of the arrow *g*. It is a common thing in die work to have the projections from the upper die cut a number of openings in the piece to be operated upon. The arrangement of the affair for removing or pulling out the upper die from the punched piece is no way different from the method described in former article. Another feature in re-punching is that the work must be put in and taken out, while in the first or direct punching the article was forced through the die and fell below into a receptacle. Die presses have been so arranged as to have sub-dies, one fitting into the other, and these do the work of two operations at once; but such presses are complicated and expensive, and for all ordinary work useless. It is a common feature in die work to have to bend the parts struck out into certain forms, as in this buckle or slide, which is generally curved into the shape of a section of a cylinder. This can readily be done in such a press as was shown; but the dies and their action are quite different. As in the case in hand we wish to bend the buckle into a true curve, so that a transverse section of *B*, fig. 1, on the line *jj* would be on the curve shown at *G**. To do this we substitute for the lower die-bed *F*, fig. 2, a die-bed with a hollow cylindrical recess. This recess is curved, as shown at *k*, diagram *H**. This diagram *H** is a vertical section on the dotted line extending from the arrow *h*, fig. 2. Diagram *I** is a plan of the lower or female die for bending. The recess *k* is best made by letting the cylindrical bottom extend across the face of the die, as indicated by the dotted lines *l l*. The die can be much shorter than *F*, fig. 2. The guide *f*, fig. 2, can also be used in the bender (or former) to locate the piece to be bent; but a little practice will be necessary to rapidly place the pieces so they will not slide on the curved sides of the die. A piece of thin metal pressed against the edge of the buckle at the point indicated by the arrow *h*, fig. 2, until the upper die has firmly caught it. The dies must forcibly be pressed together to give the piece between them the form desired. In making benders it is well to bear in mind the fact that the article will spring back a little, so that the curve of the die should be a trifle too great. For striking up designs with relief work the male die must be a counterpart to the female, but need not be executed to that degree of fineness which the female die is done. It must be kept in mind that the force necessary to strike up relief work is very great, and that such a press as described will punch out pieces of some size; still, to produce relief of any size it would not be adapted. But for bending, the press is ample for anything it will cut out. It requires a great amount of fertile ingenuity to contrive dies, both for stamping and forming the various articles which can be punched out; and we might give chapter after chapter of instruction and still leave much unsaid. When I say relief work above I mean to approach to such relief as we have on coins. Sometimes it is desirable to produce relief or struck-up work, with the appearance of engraved surface; to do this well requires carefully made, and consequently expensive, dies, together with a press of enormous power. Articles of silver or soft brass are much more easily struck up or produced in relief than gold, as this last-named metal, when alloyed to any such extent as is used in jewelry, has a hardness and elasticity which make it difficult to

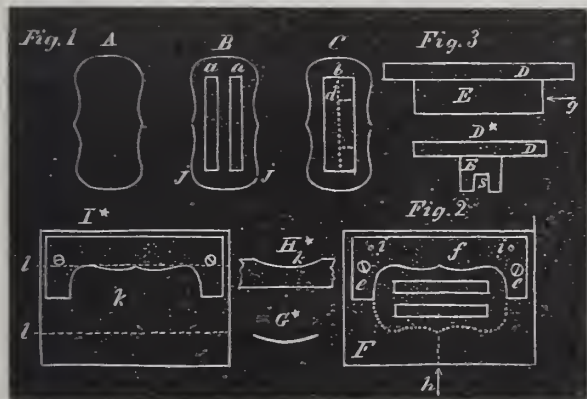

out the piece in its general form, as shown at *A*, fig. 1, which is intended to show the general form of a slide or buckle. If it is intended to make an ordinary slide two slots are punched out at one subsequent punching, as shown at *a a*. If a buckle is the article we wish to produce, the opening shown at *b* is cut out, and the tongues and bar shown in dotted lines at *d* are added by a different process. The dies used for re-punching are the same in principle as those

manipulate. In striking-up or in producing relief work it is best to make the female die the one which is most carefully made; for, if we attempt to form a piece of metal by a highly finished steel die working against a soft matrix, we lose the finer details of the relief on the male die or punch in the thickness of the metal we are striking-up. To illustrate, suppose we have a carefully wrought head on one male die—or, we will assume it is a simple punch to be held in the hand, driven against a thin plate of brass into lead or some soft metal; the brass soon takes the general form of the head in relief on the punch, but the finer details are lost, like the more delicate markings of the eyes or nostrils. For this and other reasons it is better to have the delicate work in the female die. A male center die can be made by electrotype if the back is ground flat and mounted on a steel die-bed. Such a center will do well for silver, copper or brass; gold is a little too hard, but still several hundred good sharp impressions can be made with an electrotype center if the copper deposit is made as hard as it can be by intensifying the battery. In the large majority of cases the work struck out is simply bent and united with solder, when by stoning and polishing the work is ready for the chaser and engraver. When the dies, such as are used for cutting or punching out work become dull, they can be sharpened by grinding off the face on a common grindstone; but an emery wheel, running at a very high speed, is far preferable. In grinding, the face of both the male and female dies should be ground off until a fresh sharp cutting angle is restored. And here will become apparent the policy of having a press which will not permit the dies to pass one another to any great distance. As when you come to grind the face the dies will have to be ground away to the depth at which they pass each other.

Wolfgang von Kempelen.

WATCHMAKERS, from the very date of their art, have been possessed by a desire to try their mechanical arts on something else besides constructing movements for the measurement of time. They endeavored to imitate the life of a creature, to represent the mystery of human or animal organism by power of wheels. Droz, senior and junior, were two such watchmakers; a genius of the first rank was Vaucanson, whose name will live as long as language, being the inventor of the silk-loom. We might mention many other such mechanical talents who tried their capacities in the highest branches of horology.

Similar to Bishop Gerbert, three hundred years after him arose another, Albert, bishop of Regensburg, who was called the "Great" on account of his wisdom, and favored by the people as a "Magician and Master of the Black Arts," and the stories of his wondrous works are recounted to-day (he died in 1205) by the superstitious peasantry around the winter evening's fire, while devoutly crossing themselves. The old German tradition of Faust is partly based upon his creations. It is certain that he tried to make walking and talking automata; and, according to the chronicles, he possessed a great skill for this kind of work. It says that he composed a human figure which served him as oracle, and explained to him the mysteries of all occult things. Whenever any one knocked at Albert's cell door (during the last years of his life he lived in a Dominican monastery at Cologne) this automaton admitted and spoke to him as a servant. That he had spent thirty years in bringing this piece of work into a high state of perfection. Bartolomäus Sibollus assures us that this figure consisted of flesh and bone, not the natural, but the imitated article. It may reasonably be supposed that this learned man, well skilled in mechanics, had composed an automaton that could make certain movements and pronounce several words, became his celebrated disciple. Thomas of Aquinas smashed the figure, since its talk offended him, and, perhaps, in his religious frenzy, he deemed it to be the work of the devil, although Albertus Magnus has been canonized.

In the 15th century, King John II., of Castile, caused the writings

of a scientist to be burned, being deemed a magician, in that he had constructed a talking head. Of course, also the mechanical genius was roasted at the stakes.

Apart from Vaucanson, whose automata excited the admiration of the world, a certain Abbè micul, in the last century, made two bronze heads, containing a speaking machine. Angered at the refusal of the French government to purchase them, he smashed them, and died in 1789 in great poverty.

Apart from Vaucanson's automata, there were none that excited more renown than those of W. V. Kempelen, at the end of the last century. He constructed the celebrated chess-player, and a talking machine, which expressed itself in the Latin, French and Italian languages.

Wolfgang v. Kempelen was born in Pressburg in 1734, the son of an old and noble Hungarian family. He entered the service of the state at an early age, and, during his hours of leisure, amused himself with mechanical works, for which he had a great passion. Owing to his social qualities he was a great favorite at court, and the Empress Maria Theresa frequently played chess with him.

At the desire of the Empress, a Frenchman entertained the court one evening with all manners of magnetic and mechanic performances, and was universally applauded by those present. Only Mr. v. Kempelen did not share in the enthusiasm. The Empress was astonished and demanded to know the reason of his silence. Kempelen responded that these tricks were not astonishing to him, and thought that he could do better than anything exhibited during the evening. Although the Empress knew the weak side of her chess opponent, still she expressed her doubts as to his ability. Kempelen persisted, and becoming nettled, promised, with her permission, that he would satisfy her of the truth of his assertion. She told him she would keep him to his word, when the matter was dropped, and the two engaged in a game of chess.

Maria Theresa heard nothing for several months, how or in what manner her court counsel would redeem his word. She finally concluded to treat the matter as a boast on his part, when, one evening, he craved her permission to introduce a Turk to her, who was an excellent chess player, and already seated at table waiting for her. This Turk was an automaton, constructed by Kempelen during the last six months. His very appearance caused the astonishment of the Empress. It was a figure of life size, sitting upon a heavy wooden chair, with a table before him about three feet long and two and one-half broad. But the admiration of the Empress for the skill of her court counsel grew prodigiously when she found that the automaton was a master of chess, corrected her bad moves, and finally won the game!

Of course, the Empress and the entire court desired to know the construction of the figure, but Kempelen begged permission to keep the secret to himself. He had stood at the table during the play, and it was presumable that he had either guided the moves of the Turk or that somebody was hidden within the figure. Kempelen opened the clothing of the Turk, and showed a combination of wheels and pinions, but his secret was contained in the box of the chair, and consisted in a man hidden within it, with whom the astute inventor was in secret connection.

The wonder traveled to all the chief cities of Europe, and earned fame and honor for the inventor. There was a perfect *furor* in Paris and London. While Kempelen earned renown and wealth with his chess-player, he constructed a talking machine, and exhibited it in 1778. It consisted of a box 1½ feet long and 3 feet broad, and provided with a bellows, while its wheel-work was still more complicated than that of the chess-player. When the bellows, together with its valves, were moved in proportion to the words to be pronounced, the machine uttered all syllables plainly and distinctly, in the voice of a child from three to four years old. Kempelen intended to introduce it into the figure of such a one, but was prevented, since he died soon after in Vienna in the year 1804. His son sold the incomparable works to a mechanic. The chess-player was in Paris in 1822; the talking machine was improved and exhibited in Berlin in 1828 by the mechanic Pasch.

Art of Goldsmithing in Antiquity.

BY JEAN PFAFFRATH, IN *Journal der Goldschmidekunst*.

THE GREATEST works of art of antiquity have been manufactured by the Greeks. Phidias (488 to 432 B. C.) was the most renowned artist, not alone of them, but of the entire civilized world. His greatest work is the statue of the Olympian Zeus, of which Schiller says that the

"Marvel of its age, stood proudly the statue of Jovis,
In the temple at Olympus."

But this magnificent work is lost, as well as the art of constructing it, the so called "chryselephantine," (gold and ivory,) a Mosaic work, composed of small pieces of gold and ivory. The entire manner of construction is a secret to us. It is said that Phidias himself sunk down on his knees in the ecstasy of adoration. The ideal of deity incorporated in the material shape of this statue filled the beholder with awe and reverence; a divine majesty beamed from its eyes, as well as sublimity and goodness, before which the Greeks bent their knees, involuntarily overpowered by pious reverence. Phidias said that he had been stimulated by a sense of Homer, when Zeus, supplicated by Thetis to accord her revenge for the insult which Agamemnon had conferred on her son, Achilles, inclines his head in affirmation, and before which motion the entire Olympus tremble; Zeus was represented as sitting upon his throne, and of an altitude reaching up to the 60-foot high ceiling of the temple. The gold was introduced especially in the rich embellishments of the throne, and in the flowers with which the cloak enveloping him was adorned. Also the sandals of the god, as well as the articles held in his hand, were of gold—in his right a goddess of victory, in his left a scepter surmounted by an eagle. The throne, which rested upon four feet, was ornamented with a quantity of figures in half-relief, and pertaining to the history of the gods and heroes.

Another celebrated of his works is the 36-foot high statue of Minerva for the Parthenon at Athens. The artist had at first proposed marble, the people were satisfied, and accepted his proposal. But when he added that "marble would be cheaper," all exclaimed, unanimously: "No, no; gold and ivory." The gold used for this statue weighed 40 attic pounds, and was of a value of \$40,000. Furthermore, the bronze statue of Pallas Athene, cast from the booty of Marathon, and two bronze figures, Apollo and Diana, for the Delphian temple, as well as many other works of art of metal and marble. He cut from a large block of marble which the Persians had drawn to Greece and abandoned during their hasty flight, in order to erect a victory column upon the Plain of Marathon, the statue of Nemesis. Other of his works are a marble group of twelve Greek heroes surrounding the Trojan horse; Minerva he represented three times; Aphroditus, etc.

The Greek temples were rich in statues and other objects of the noble metals. The Oracle of Delphi possessed an exceeding large wealth. Alexander of Macedony (a predecessor of him who is sur-named the Great) presented them with a golden statue of himself. Cræsus, whose name is known everywhere, on account of his riches, once sent them 117 golden bricks, 6 hand-breadths long, 3 broad, and 1 thick; moreover, a lion, of fine gold, 10 talents in weight; two mixing jars, one of gold, the other of silver, the latter of a capacity to accommodate 600 bucketfuls; four silver barrels, a tripod, a shield, and a female figure of gold, a quantity of gold basins and silver dishes, as well as the costly belt and necklace of his spouse. The Lacedæmonians sent back to Cræsus, as Herodotus says, a stoneware mixing jar, holding 300 bucketfuls, and the mouth of which was ornamented with small animals. The same author also mentions a metallic dish, adorned with lions' heads, which was manufactured upon Sarnos. Also Callikrates and Myrmecidos are mentioned about this time as articles of noble metals. The first Greek silver coin was made by Phidon of Argos upon the island of Algina, about 900 years B. C.

Mys was an apprentice of Phidias. The temple of Bacchus at Rhodes contained many vessels made by him, representing drunken

genii and bacchanalians. It is said that Mys represented the Battle of the Centaurs upon the shield of the Lemnic Minerva of Phidias. The same temple also possessed several drinking cups adorned with hunting scenes by Akragas. In another temple of Rhodes, dedicated to Minerva, were preserved a large quantity of the works of art of Boëthus. Pliny praises his skill in the construction of silver works, and Cicero mentions a large jar, artistically worked by Boëthus, which Verres brought with him from Sicily in 74 B. C.*

Among the silversmiths, Mentor, who lived about the time of Alexander the Great, was the most celebrated. Works manufactured by him were afterward in great demand in Rome. Above-mentioned Verres also owned two bowls, called for the inventor *thericlea pocula*, and manufactured by Mentor. Lucius Crassius possessed two beakeos, by the same artist, for which he had paid 100,000 sester-ties. The Roman poet Martial describes a lizzard, which was very life-like; also the poet Juvenal says that his works were universally sought in Rome.

According to Pliny, Calamis was skilful chiefly in representing horses; of his works one is especially extolled, a statue of Æsculapius, the god of medicine, and consisting of gold and ivory. Myron, especially famed for the multiplicity and novelty of his works, manufactured a cow from metal, so natural that even animals were deceived; a quantity of epigrams were written on this cow. Also a drinking vessel, adorned by a wonderfully constructed snake, made by him, is highly lauded. Polygrotus, the inventor of enameling, or the art "of painting with fire," as it was called by the ancients. Furthermore are mentioned Skopas, Mandos, Euphranor, Polykletus, and Lysippos; the latter is chiefly famed for bronze casting. Upon the order of Alexander he constructed twenty-five bronze horses in memory of the Macedonians fallen on the Granikos; almost two hundred years afterward they did honor at a triumphal procession of Mummius, who had plundered them from the Macedonian city Dion.

Already at the time of Phidias, the Greeks universally wore ear pendants, rings, pearl chains and bracelets, and gold and silver vessels, adorned with jewels, glittered upon the festive board. The noble metals were used not alone for personal adornment, but furniture also was frequently inlaid with them. Bedsteads were frequently of cedar or ebony, inlaid with gold and silver, ivory and tortoise shell. Alcibiades, who had set the first example of luxury in war, by using a golden shield in battle, was very quickly imitated by noble Athenians; at his return from banishment he was presented with a golden crown by the Athenians.

Alexander the Great had a body guard of three thousand men with silver shields. The officers of Alexander were rewarded with golden crowns upon their return from India; golden vessels are often mentioned as figuring in the sacrifices of Alexander. He poured a drink sacrifice out of a golden vessel into the Hellespont, and a quantity of golden vessels were cast into the sea in India, in honor of Toseidon. These pieces, however, were booty taken from the Persians, because, in the discourse delivered by Alexander to his soldiers, when they demanded to return to Macedonia, he says: "I received very few gold and silver vessels from my father."

That the goldsmith's art was but little practiced in Rome immediately after its founding can be seen by the fact that only after more than a hundred years statues were erected to their gods in the temples. At the death of Numa Pompilius the neighboring nations sent the ornaments for decorating the dead. Even the ensignia of the kingdom had to be conquered in battle, since the fourth king, Tarquinius Priscus, obtained them from the Etruscans upon the conclusion of peace—an upper garment embellished with ribbon of gold, a golden laurel wreath, and an ivory throne and scepter. The Etruscans occupied a comparatively eminent position already in the

* This Verres had such a mania for collecting art works, that during the three years of his governorship of Sicily he literally acquired, either by force or purchase, everything that had even a comparative art value, be it picture, statue, gem, vessel, etc., and the Greek towns upon this island were filled with art treasures of every kind.

art of elaborating the noble metals, more especially in bronze castings, and articles found in Rome during the first few hundred years either emanated or was copied from them. The first Roman coin were first struck under the sixth king Servius Tullius, 574 to 534 B. C. They bore the picture of an animal of sacrifice, (*pecus*), whence the name *pecunia* (Latin for money). The word *moneta*, whence the German word *Münze*, signifies "token of remembrance."

These conditions only changed in the fifteenth century, after the building of the city, when the working of the noble metals was commenced. The first Roman coins were struck in the year 269 B. C., after the submission of Italy had been effected, whereby Greek art and science were transplanted to Rome by the Greeks living in southern Italy. The first gold coins, according to Pliny, were struck to commemorate the defeat of Hasdrubal, in the year 207 B. C. How much the finer culture of the Hellens was revered can be seen by the fact that Claudius Marcellus, after his victories over the Gauls, 220 B. C., sent a golden beaker to the Delphian Apollo. The law issued against the luxury of the women (*lex oppia*) in 215, shows that much ornament was worn already.

Countless riches came to Rome by its continuous wars, which were publicly exhibited in this triumphal procession. Flaminius carried in his procession, after his victories over Philipp the Third, of Macedonia, (194,) a quantity of art treasures in gold and silver, among which were one gold and ten silver shields. Aemilius Paulus (167,) after beating Perseus, the son of Philipp, and his allies, brought a countless number of gold and silver vessels from the treasury of Perseus, among which were many pieces dating from Alexander's time, therefore, had first been plundered from Asia, and had to do duty in a second plundering. Aemilius caused a Greek artist to construct a sacrificial dish from ten talents of gold, adorned with many jewels. He also brought four thousand golden crowns, which the vanquished Greek cities had to present to the victor. The Rhodians, at the conclusion of peace, delivered a crown of a value of ten thousand pieces of gold. At the triumphal procession of Lucullus, after the war against Mithridates the Great, by Portus, could be seen a gold statue of Mithridates, six feet high, and one of his shields, richly ornamented with jewels. Sixteen hand-barrows, with silver dishes, and thirty-two others, with golden ones, as well as bumpers, etc., and finally 160 mules, laden with gold and silver coin. At the procession of Aricius, to commemorate his victory over King Gentius of Ilyria, were many golden lamps. Julius Cæsar brought 2,822 conquered golden crowns to Rome. At the plays, which he instituted for the people, he had the entire Amphitheater roofed over with silver, and 640 gladiators fought in silver armor. Antonius conducted King Artavas, of Armenia, bound in gold chains, to his enamorata, Queen Cleopatra, of Egypt. A silver eagle was carried in front of the Roman Legions, in place of cloth standards. The soldiers received gold and silver bracelets for bravery; he who first scaled an enemy's ship or wall received a golden crown.

The art of goldsmithing begins to improve with the Romans in about 150 to 120 B. C. Of course, it was much accelerated by the incredible quantities of the noble metals which the vanquished nations had to deliver as tribute to Rome. All the dishes were of silver, frequently of gold, in the houses of the rich. Instead of mirrors of glass, (an invention of a later period,) they consisted of polished tablets of gold or silver, often of human size. Hand-mirrors generally consisted of a plate of silver with back of chased gold, the rim set with jewels, and the handle of artistic ivory cutting. To what an excess the embellishment of mirrors went can be learned from an examination of Seneca. "A dowry which once the Senate presented to the daughter of Scipio, does not suffice at the present time for purchasing a mirror for the virgin of a manumitted."

Caligula must have been a great friend of gold, and who had reduced its spending to a veritable science, because he rolled sometimes naked upon pieces of gold. Everything for his use must be wrought of gold, and even his horses were fed from golden troughs. Heliogabalus went still further; when he drove out, the space between

his room and the carriage waiting to convey him was strewn with gold dust. Although his dresses were oversown with jewels, yet he never wore them twice. The golden vessels, from which he had been served during day time, he divided at night between his friends, and frequently distributed gold and silver, pearls and jewels among the people and his soldiers. But not alone the emperors were thus lavish with gold; they were duly imitated by the patricians, although not on so large a scale. The son of Antonius once rewarded a witty remark with all the silver dishes on the table. The noble metal, as such, was barely held of any value by the magnates; it obtained value only from the artistic work expended upon it, wherefore, the goldsmith was paid royally. Everything, however, was eclipsed by the "Golden House" of Nero, in which all the furniture and dishes consisted of the most precious kinds of marble and wood, gold and silver, pearls and jewels.

Among the most famous artists during the Roman luster period, and especially mentioned: Praxiteles, who made the first silver mirrors; they consisted of white metal originally—a mixture of copper and tin. Posidonius was celebrated for his elevated style of workmanship, and Cicero mentions a celestial hemisphere constructed by him, in which the sun, moon and planets moved as on the firmament. Laedus is renowned for his battle pictures; Stratonikus by the pictures of the old sages, and Zopyrus, who lived at the time of Cæsar, by his beakers in chased work. The highest pinnacle of this art was attained by Pitheas, by the diminutive dimensions and artistic finish of the figures represented. He manufactured a beaker two inches high, with the representation of the carrying off of the palladium from Troy by Ulysses and Diomedes, which was purchased with ten thousand sestertiae. Zenodorus, at the time of Nero, is well known as an imitator of Greek works. Beside this, Antipater, Ariston, Arkeselaus, Cyzizemes, Decius, Eunicus, Euricion, Hecataus, Menelaus, Pasitetes, Tauriscus, and Teucer.

If we examine the contemporaneous art by the Gauls and Germans we will find total obscurity; although several Gallic tribes were already skilled in the manufacture of metal works. They did not possess a general contemporaneous culture, however, because rivers, mountains, etc., not alone formed natural barriers, but frequently veritable limits of culture. The noble metals were not used for coin, since animals chiefly represented the standard of value; they worked them only into personal ornaments and for the embellishment of weapons; very little was used for vessels. And how unwieldly their shapes were can often be seen by excavated articles from that epoch. That the Allemanni wrought in the noble metals is reported by Julius Cæsar, although Tacitus says: "Gold and silver is denied to them—by the favor or the anger of the gods?" Cæsar says that they bordered the rims of their drinking cups with silver. The buckle used for holding the dress together is also at times wrought of gold, generally bronze, however. And that they understood the value of the Greek and Roman is seen by their avidity to acquire the possession of such. A princess caused several goldsmiths of Fafiana (now Vienna) to be secretly apprehended and brought to her; she made them manufacture an ornament for her, according to her plan, keeping them prisoners meanwhile. They knew how to obtain their liberty, however, by seizing on the son of the princess and threatening to kill him if they were not liberated at once.

The Wends appear to have been similar to the Chinese of to-day, by showing a predilection for the neat luster of silver over gold, because many silver ornaments are found in their graves. The Huns, when they appeared upon this world's stage, were unacquainted with every gold ornament.

Correct Local Time and How to Obtain it.

WE HAVE, in this series of articles, considered pendulum clocks and the various disturbing influences to which they are exposed, and pointed out how these defects can be modified and to

a great extent annulled. It remains for us now to consider briefly movable timekeepers, such as marine chronometers and pocket watches, and then give the additional parts for the clock with electric lift, to run one year. There has been a very general tendency for the last ten or twenty years to use box or marine chronometers for local time purposes. This can be accounted for in various ways: Pendulum clocks are difficult to regulate except one has a transit or some other method for determining local time. And no matter how well a clock was regulated in, say New York City, if removed to any location north or south, would vary. On the other hand, a box chronometer, regulated to a given rate, would hold it, no matter to what part of the earth it was taken. But this sort of mania for chronometers was taken advantage of by certain dealers, and all sorts of old and worthless affairs were palmed off on the watchmaking fraternity as being just the thing they wanted. Suppose now, to illustrate, a ship master has an old and worthless chronometer that he knows is not even safe to use for the coasting trade; he sells or trades it for something better—for these sea captains are not to be deceived about the performance of their chronometers, consequently some other market must be made, and the best victim is some watchmaker who has no means at his hand of determining an error in his time to the extent of two or three minutes. But the reader of this series of articles, if he has profited by the instruction given, can, by

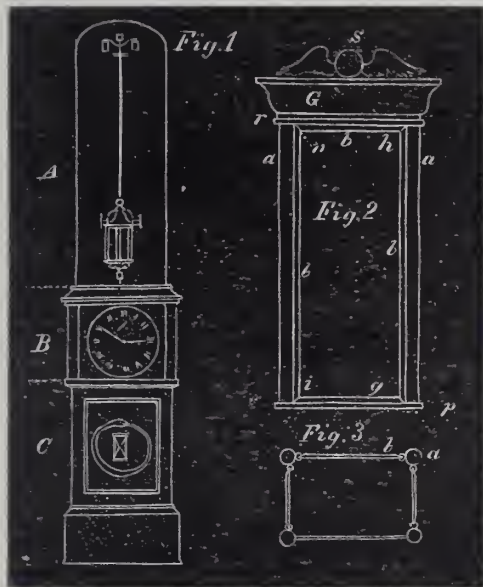

the simple and inexpensive affair described in one of our early articles, determine the local time to less than five seconds—a degree of accuracy quite sufficient for all business purposes. There is no chance for an argument on the statement that a fine pendulum clock is by far the most accurate and reliable timekeeper known, and for adjusting pocket watches to time, and rating in heat and cold, isochronism and position, such a clock is absolutely indispensable. A few words in relation to pocket watches—we hear all sorts of stories told about watches running for months with only a variation of two or three seconds. All this is well enough to outsiders and for outsiders, but those whose business it is to make and adjust fine watches, know that all this sort of thing is abject twaddle, and the watch, no matter how fine it is, which will go through the positions, say lying down, dial up, dial down; hanging, stem up, stem down, and—if an open faced watch—three up and nine up; notwithstanding its adjustments to isochronism, heat and cold and position, and not vary in any of these positions more than two or three seconds in twenty-four hours, is a rare good one. Even marine chronometers have their ship rate and shore or shop rate. So all things considered, a pendulum clock, taking advantage of the methods pointed out for remedying disturbing influences, is the standby for astronomical, adjusting and rating purposes. The writer made mention of a clock to run one year some three months since; such a clock would be a curiosity, and, if elegantly made, would be a very useful ornament in any jewelry store. At fig. 1 is shown the general form of such a clock. The whole

affair should stand about nine feet high; five for the base, and four for the bell glass covering the pendulum. It is hardly necessary to give anew all the details, as there is no difference in the train of wheels (except having one additional wheel) to the one shown in the March number of the present year. This wheel is placed at the commencement of the train. The wheel *A* (in March, '83, number) in the year clock, instead of having the spool and maintaining wheel, is supplied with a pinion, and the additional wheel just mentioned becomes the great wheel and takes the spool and maintaining wheel. The weight described in the February number is increased eight times, and will fall during the year three feet. Another change also takes place in the escapement; the pinion *f* (March number) should have sixteen leaves instead of eight, as in the present case we are using a pendulum beating seconds. A correction should be made in the figures in this (March) number; when the "wheel" diameters are given for *A B C*, instead of 2.0784 it should read 3.0784. The added wheel spoken of above is the same size as *A B C*, *i. e.*, 3.0784 inches and 96 teeth. If the reader will go back through this series of articles in regard to the steps (if we may be allowed the expression) taken to explain why we recommended the plan of employing an electric current to lift a small weight as a constant power to the pendulum, and also in meeting all the disturbing influences, he will see that we have met them in detail, and pointed out how these disturbing influences can be reduced to their *minimum* effect. In fig. 1 it is supposed that all the principles which have been spoken of and described are combined and embodied in the present model. It is not to be supposed, however, that the writer offers this cut as *the* perfect model clock, for such is not his intention; he only gives this as one way—one plan, by which the combination can be effected. The upper part at *A* is shown as a high bell glass, *B* as the part containing the movement, *C* the pedestal. These different parts can be made and ornamented to please the taste. Something of wood with metal panels would probably be in as good taste as anything. The bell glass at the top can be dispensed with and a box of plate glass with brass tubing as a frame work, can be used. The tube forming the outside corners should be $1\frac{1}{4}$ inches in diameter, and the small tube inside for holding the glass $\frac{1}{2}$ inch in diameter. The arrangement will be understood by inspection of fig. 3, which is a horizontal section of the tubes and plate glass, the small tube being slotted to receive the beveled edge of the glass. By filling these small tubes with cotton wool, a perfectly dust-proof case can be made. The small and large tubes are soldered together. The small tubes at *g* and *h* are attached to the cap and base, but made to join tightly at the bevel joints at *i n*. The plates *r p* can be bolted through the tubes *a a*. The O.G. top *G*, fig. 2, can be either of wood or metal, preferably metal, as also the winged ball *s*. The electric arrangement is in no way different from the method described in former articles, and the battery will need renewing in the same way and time. An earth battery, formed by burying large plates of copper and zinc in the moist ground below the action of frost, would no doubt afford electricity enough to supply the magnets for a whole year, but it would be more bother and expense than to renew one cup every week, and much more certain and satisfactory. The writer thanks his readers for their attention, and if he has been so fortunate as to suggest anything new which will serve to help solve the problem of pendulum clocks, he will feel as though the time of both has not been misspent.

[THE END].

High Class Jewelry.

FASHION of late favors much that is curious in jewelry designs showing gem groupings. A brooch of rare beauty and great value was recently designed and finished by one of our popular jewelers. The setting contained twenty-six precious stones, comprising eight different specimens, producing a gorgeous effect, sending forth a myriad of richly-tinted splintered lights.

A brooch design of artistic beauty is a copy of the aster flower, which is surprisingly true to nature. The size of this pin is four inches in circumference, the pure white center is executed in seed pearls, the outer petals are of rubies, emitting luminous blush-red rays glowingly beautiful. The passion-flower, with its golden calyx inclosing the corolla, is a remarkably pleasing design; the stamens are formed of clustered sapphires resting on dainty filaments of rolled gold.

A unique brooch of the four-leaved clover model is singularly artistic and suggestive of youthful romance. This design is a clustering on filigree gold work of Siberian green garnets, a fashionable style of gem, and quite novel, being very scarce and entirely unknown until within a few years. The glitter of the green garnet is not so intense as the emerald, yet this new stone is brightly beautiful and has proved of great assistance in giving a peculiarly fine shading to gem combinations. The green garnets found in North Carolina are very valuable; the supply is limited and hence their great appreciation with admirers of jewel novelties.

A costly pendant, intended for a birthday souvenir to a well-known banker's daughter, presents a singular design and one of great originality. The shape of this royal trinket is oblong. It is encircled with rose diamonds, then there are four rows of rubies and emeralds, alternately arranged. The center design is a fac-simile of a tarantula; the body is formed of a large-sized emerald, around which are tiny rubies; the eyes are black pearls, and the diamond-studded legs are spread in glittering beauty over a web of gold, so light in construction the slightest breath of air will produce a tremulousness which gives a crawling aspect to the spider that is wonderfully realistic, a mechanism that will doubtless fail to gain appreciation with those ladies who are easily agitated.

One of our leading houses sold the other day a rare specimen of an unset Alexandrite gem at a cost of \$1,000. This style of stone is a great novelty. By day it is of a sparkling green hue, with a pretty glimmer of red twinkling in its breast; presto, by gaslight the emerald hue has entirely vanished. This transposition is really wonderful—instead of the olive green there appears a crimson hue of startling refulgence. In the days when superstition held such sway marvelous things would doubtless be said respecting the mystery of this color phenomenon. The Alexandrites are found in the island of Cyprus and the Ural mountains. This gem is named for the Emperor of Russia. It combines admirably with diamonds, pearls and the aqua marine stone.

A stone of bluish green called beryl has recently received special consideration in clustered designs. This gem is a native of Brazil and Ceylon; it shows off to excellent advantage in connection with rubies and sapphires and colored enamels. A square locket of rolled gold, with a circle of diamonds inside the rim of polished gold, has a decidedly beautiful center design of a graceful wheat spray composed entirely of rose diamonds, and perched on one of the long leaves is a butterfly gorgeously arrayed in rubies, beryls, diamonds, pink, white and black pearls, malachites, amethysts, topaz, sapphires and opals, a magnificent assemblage of rare jewels of great price.

Among the interesting facts respecting precious stones, it is not generally known that the first determinative in classifying them has reference to their hardness and specific gravity, and accordingly are they said to be species of such or such a family, no matter what the color may be; for example, the Oriental amethyst belongs to the sapphire race, and so does the Eastern topaz, etc. There are a number of differently tinted sapphires; the common belief is that this gem is always blue, on the contrary, it is of various shades—pink, violet, white, green, yellow, red and black.

Among the animal designs in jewelry perhaps the elephant has been more liberally represented than the other inmates of the menagerie. At one time the jeweled pig was very salable, and little gruntings with ruby eyes and diamond studded backs dangled from bracelets and chatelaines. For the present we are greeted by the charming spring swallows radiant with diamond wings and dottings

here and there of gray pearls on rolled gold, commingled with ash-tinted enamel, the whole design exquisitely effective, so correctly representing the live bird, which is the fancy of the season.

A very elegant shoulder pin to fasten any sort of lace garniture, presents a picturesque design, in the shape of a double bar, with scalloped edges richly adorned with diamonds, pink and black pearls. Another style of shoulder pin represents a large beetle standing on a leaf showing autumnal tints. This brilliant array of shades is marvelously well presented in gems. The bug glitters with the beauty of sapphires, opals and black pearls artistically grouped.

There are no very decided changes in ear rings. There has been floating rumors that large hoops will be revived. There is not much danger of these very unbecoming ornaments receiving notice so long as the short ear rings are sold. Solitaires are fashionable, but the *chic* in this line of goods is the large ruby known in Europe as the "lord of rubies." The finest specimens of this valuable gem are taken from the Burmah mines belonging to the King of Burmah, and Mrs. Grundy says that His Majesty is such a spendthrift he is glad to sell some of his rubies in order to keep himself out of debt.

An ingenious novelty in bracelet designs is formed of rolled gold correctly resembling skeins of silk, with pretty gold slides adorned with gold balls showing chased work, in the center of which nestles in sparkling beauty a diamond of the first water surrounded with emeralds. The ends are beautifully finished with gold balls; one is passed through a single slide and securely holds the bracelet together. Bangle bracelets are only fashionable for misses.

The "shopping bracelet" is rather curious; the design is wholly American, and is formed of repeated medallions, joined by gold links that are passed twice around the wrist, and carried through an open slide, where the pencil is cunningly concealed.

The novelties in necklaces are numerous, a style of ornament that is daily becoming more and more fashionable; all sorts of precious stones are employed. A pearl necklace of three strands is on sale for \$17,000. The pendant is one large pearl about the size of a wax bean, and is valued at \$2,400. A necklace arranged in black pearls has a fabulous price, \$30,000. This costly ornament is considered a great curiosity.

A parure made in this city for the wife of a wealthy miner West, is valued at \$86,000—the diamonds ranging in weight from fifteen to thirty-five karats; the other gems are emeralds, pearls, rubies and sapphires of various hues.

Views of Correspondents.

This department of THE CIRCULAR is open for communications relating to the jewelry trade, but the editor does not hold himself responsible for the sentiments expressed by contributors. We invite correspondence, but require that it shall be free from all personalities, and the writer's integrity guaranteed by the disclosure of his true name to the editor. Anonymous communications will not be noticed.

OUTSIDERS AND THE RETAIL TRADE.

To the Editor of the Jewelers' Circular:

Have been watching your arguments in favor of a government stamp, and must confess I can see but little good, and a great deal of harm in it to the jeweler. While it would prevent a few jewelers from being swindled by unprincipled jobbers, it would enable all outsiders to handle jewelry on an equal footing with the jeweler. The goods would then show for themselves just what they are, like a silver dollar, and the purchaser would as soon buy of the grocer or hardware merchant or anywhere else, as he would have no risk to run. As it is now, when a person wants an article of any value in the jewelry line, he goes to an experienced jeweler to obtain it; he is afraid to risk an outsider. I do not find the sale of Cheap John and auction goods a very dangerous rival to our business. It is a class of goods the jeweler don't want to handle any way; I, for one, am perfectly willing that outsiders should have all that class of trade.

But it is the handling of good goods by outsiders that hurts us, the same line of goods that we handle, the best in the market. Outside dealers are an easy prey to the irresponsible Cheap John jobbers; this is their greatest difficulty in handling jewelry; remove that difficulty (which the government stamp would do) and you give the dry goods, grocery and clothing merchants the decided advantage of us in selling jewelry, for this reason: Everybody has to go to these merchants often every month in the year to buy goods, therefore jewelry in these stores is exposed to the public much more than in a regular jewelry store, and they will buy more. I will guarantee that if a jeweler will put in a good stock of dry goods, clothing or groceries that he will increase his jewelry sales.

A word to those jewelers who have had trouble in obtaining good goods, and have been bit by irresponsible jobbers. This is all their own fault; there are plenty of good responsible jobbers to buy of, that will guarantee their goods to be just as represented, and will make their guarantee good should anything prove to be faulty. I have never had any trouble with poor goods except when I bought of some clap-trap drummer that came along that I knew nothing of. Any jeweler that makes a business of buying of Dick, Tom, Harry, and every drummer that comes along may rest assured that he will get bit twice out of three times, and deserves to be. Every jeweler should select some good responsible house and deal principally with that house, and he will have little trouble in obtaining goods that will give satisfaction to his customers.

I like your article in the May number on "Retail Dealers and Outsiders." I am in favor of jewelers branching out and adding other business to theirs; the jewelry business alone, in many places, will not "pan out" any more. The jeweler should add anything and everything to his stock that will sell. The best means of fighting fire is with fire.

G. W. H.

Columbus, Kan.

[Had the trade united three or four years ago to obtain the legislation we then suggested necessary to secure a government stamp to indicate quality, it could have been done, and the greatest evil the trade suffers from to-day would not have troubled them. The outside trade was then exceedingly limited, and would have been crushed out by the adoption of a government stamp. But that day has passed, and such a stamp would be of no avail, for the outsiders have got too strong a hold, and cannot be driven out. Our correspondent is mistaken in supposing outsiders deal principally in cheap goods. In the large cities many of them are handling large quantities of fine goods, and, at the holiday season especially, make a great display of them. They have found their profit in handling jewelry, and so long as they do so they cannot be prevented from buying and selling it. Neither a government stamp nor any other will cure the evil at this late day. It was the business of the state associations to have prevented outsiders getting a foothold in the first place, but they were led by the nose by a few scheming persons, who were seeking their own advancement, and instead of trying to cure evils that were rapidly growing, they frittered away their time and energies chasing visionary trade watch companies, intangible trade jewelry manufactories and impractical Guild stamp contracts. Had a few wise, judicious men taken the leadership these associations could have been made a power for good, but falling into the hands of persons whose selfishness was paramount to everything else, the opportunity has been lost, and the associations, instead of cementing the retail trade into one harmonious, united body, have bred dissensions and dissatisfaction in the trade. The incompetency of these associations was the outsiders' opportunity, and they have now become so strong and formidable that the retail trade is placed on the defensive to hold its own in the competition for public patronage. The only thing to do is to retaliate by carrying the war into the camp of the outsiders. Let every retail dealer carry goods, of whatever nature, that the public wants, and so make his establishment so attractive that the public cannot resist the temptation to visit it. Outsiders who carry a diversified stock must be shown that the retail jewelers

are as good merchants as they and quite as ready to serve the public with whatever it wants.—ED.]

THE RETAIL DEALERS AND THE OUTSIDERS.

To the Editor of the Jewelers' Circular:

The writer has read with a great deal of interest your able editorials in the April and May numbers of THE CIRCULAR, and realizes that there is a great deal of truth contained therein. It appears to be a well-settled fact that the outside trade has taken a firm hold of our goods and have come to stay, especially in the large cities throughout the whole country, and it is altogether too late for the associations to change it. Still, such being the case, instead of the associations laying down, there is all the greater need of their existence, and more of them should start up, and those already started should do all the more to increase in strength and numbers, for there is other work to do besides fighting the jobbers and manufacturers, and always will be, so long as the jewelers themselves do not work in harmony, and continue to cut their own throats by endeavoring to run their competitors out of trade.

It is all very well and proper for the legitimate trade to withdraw their patronage from all jobbers and manufacturers who cater to this outside trade, but it is far better for the legitimate trade to band together in state associations under the supervision of the U. S. Guild, in order that the jewelers may become well acquainted with each other and combine together for mutual benefit and protection in uniting on a uniform price list for bench work and a reasonable margin on goods. As it is now, too many in the trade have no confidence in their competitors, and if a patron steps in their place of business and says they can get work done or buy goods for a less price at the store across the way, instead of remaining firm for the price charged, fall in the trap set by the customer and sell for a price too small to be remunerative.

A better acquaintance of the trade with each other through state associations would bring about a better state of affairs, and make the trade reach a better business level, even if it did not drive the outside trade out of the way.

Your correspondent don't take much stock in the remedy for outside competition recommended by THE CIRCULAR, however, there being two very good reasons to operate against it; the first being want of capital, perhaps nine-tenths of the trade now not being able to carry the necessary amount of stock to do a successful business without putting in goods that rightfully belong to other lines of trade.

The second reason is, in nearly every town where outsiders have put in a stock of jewelry, all the dealers in such outside lines have not put in jewelry, and if the jewelers should add a stock to their business such as is sold by these infringing outsiders, the jewelers would be doing to their outside friends the very injustice they do not wish done to themselves. For instance, in the town where the writer resides, there are six dry goods stores, three of which carry pretty fair lines of jewelry, while the other three keep nothing of the kind. Now, to carry out the idea suggested by THE CIRCULAR, in order to pay off the three transgressors, the three who behave themselves are to be treated exactly the same as those who do not. No, Mr. Editor, the thing won't work. Try again, and perhaps you may finally hit upon some plan that will remedy the evil. The eyes of the craft are on you, so keep at it, and in time some good may come of your efforts, but, at any rate, do not advise the disbanding of the associations, but do all in your power to aid and assist in getting them into a strong and lasting brotherhood.

In this connection your correspondent would like to say a few words in reply to "Iowa," who appears to be so afraid the Guild stamp is going to injure him. Let him rest easy, for if he is afraid the Guild stamp on goods will injure them, he is not obliged to handle them. Supposing the contract was made between the Rockford Silver Plate Co. and Mr. Boynton, the Guild not being an incorporated body, the contract is just as binding and the bond just as good.

There is very little encouragement for anyone to make an effort to benefit his fellows, for no matter how hard he works or how much good he strives to do, the very ones he is laboring to benefit give him the cold shoulder and say he has irons in the fire, no matter how unselfish his motives may be. Mr. Boynton has spent much time and money, and his efforts have resulted in doing much good, for it is through the work begun by him that the catalogue nuisance has been abated, trade more closely confined to its legitimate channels, and a uniform price list for bench work inaugurated and started on its way towards success.

With the work thus well begun, is it courteous or gentlemanly, for the retail jewelers especially, to keep up the incessant distrust of Mr. Boynton's motives, simply because he is so enthusiastic on the Guild stamp, a stamp gotten up to be applied to goods no one but jewelers can handle, and which shall be placed only on the best grades of goods—goods which the consumer may be assured will be worth the cost? T.

To the Editor of the Jewelers' Circular :

The article in the June number on "Retail Dealers and Outsiders" hit a *very long nail* right on the head, and if it can be *driven all the way into* the understanding of that great company of dealers who persist in doing their own work, good results are sure to come to any awakened mind who will put its valuable teachings into practical effect. I know of more than one jeweler with good stock, located at good points, who have lost their *buying* customers because they preferred to sit at a bench and "putter" over a watch job for 50 cents rather than be in the position to make a \$5 profit on *selling*. Any jeweler who sells as low as \$5,000 a year can *afford* to hire a watchmaker, and *cannot*, in these days of abundant supply and cheap wages, afford to work himself. He can receive and deliver work himself, and thus keep up direct and pleasant intercourse with his customers. A watchmaker should be kept in the *back* of the store, where he can work without interruption. The present plan, so much in practice, of putting workmen at the front window, is a pernicious one, as the attention is so often distracted by whatever is passing, and much time is also lost by the cheap gossip of so many who "just drop in to get the time." Furthermore, the allowing of workmen to come into direct communication with customers is an unbusinesslike evil that has cost dear to many a jeweler—the workman, by direct intercourse, becomes introduced and acquainted with his employee's customers, in his time and at his expense, and finally, when his circle of acquaintance is large enough, hires a neat dry goods store window and lives on the customers of his old "Boss," and induces the dry goods man to put in jewelry. We know of several dealers who have put the watchmaker *back*, and are surprised at the good results—increased and *better* work.

"Choose whom you will serve." Will you be a live *merchant* carrying a clean, nice stock, and, by courteous and plentiful attention, invite *purchasers*? Or, will you, like our watch key friend in the article, become a sour, crabbed watch putterer, that saves at the *spiggot* and *loses* at the *bung hole*?

An "outsider" will never attempt to steal your business if he sees you are watching it. Good fences keep out stray cattle. We would say "serve him right," of any farmer who did his own blacksmith work while his neighbors ox and ass were eating up his crops. Put up *your* fences, brethren.

Yours for reform,

LIZZIE PINCHEM.

Lathes and Lathe Work.

BY THE MODEL WATCHMAKER.

THE winding arbors of Swiss watches are so frequently disabled that a consideration of them would not be out of place. The troubles to be met here are the wearing off of the square where the key goes on, and the destruction of the teeth and click of the ratchet.

We will omit the restoration of the square, as this subject has been treated in recent articles on English fusee arbors; but the ratchet wheel is of so much importance and occurring so often that a minute description of the manner of treatment should be of interest. When the teeth of the ratchet wheel will admit of refiling or *touching up* with a file, this is the best course to pursue. But a good deal of judgment is necessary to determine whether such restoration is going to leave the winding work safe. If one or more teeth are broken off and gone, no filing up will put the affair safe. In fact, it is only when the teeth of a ratchet wheel is worn off at the ends that touching up with a file will answer the purpose. For filing up, the ordinary so-called ratchet file has too sharp or acute an angle; the best file for this purpose is what is called a dove-tail slide file, and the cutting angle should be about 50 degrees (the ordinary thin square file being 60 degrees), such a file sufficiently undercuts to make the lock between the click and ratchet safe, and still does not make the tooth too weak. The idea is shown at fig. 1; at *a* is shown a dotted

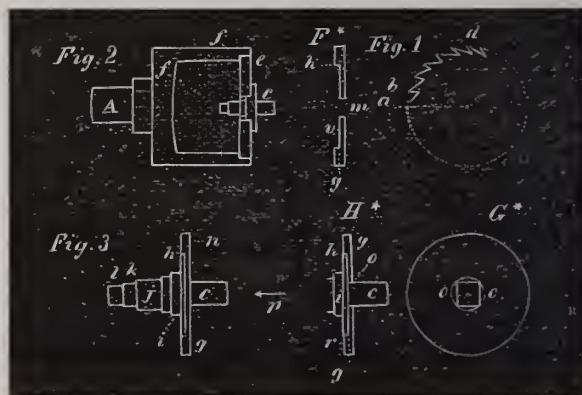

radial line; the tooth should be slightly undercut from this as shown at *b*, but under no consideration should the tooth be filed to the attenuated condition shown at *d*. If teeth are broken out, or even half of the tooth broken off, the best way, if the watch is a fine one, is to put in a new arbor, that is supposing the arbor and ratchet to be in one piece, or a fixed ratchet, as it is termed; but in the great majority of cases the watch is a cheap one and some more inexpensive mode must be adopted. The usual way of doing this job is to put a new loose ratchet over the old and worn out affair, letting the ratchet bridge hold it and the arbor in place. This method, when well done, answers an excellent purpose, and a great many watchmakers adopt it, and yet very few do the job well. The best chuck for this job is the hollow chuck, described in a former article; but as it is unpleasant to refer too much to former articles the chuck is shown in vertical section, on the line of its axis at fig. 2, *A* representing the screw going into the lathe, either of the American or Bottom type; *f* the hollow chuck; *e* a disc with a hole just large enough to receive the largest part of the winding arbor *c*. It is important that the lower surface of the old ratchet should rest flat against *e*, as the subsequent truth of the winding arbor depends on it to a great extent. At fig. 3 is shown a magnified section of a winding arbor on a line with its axis, *c* representing the winding square; *g* the ratchet wheel; *i* the bearing in the barrel bridge; *j* the screw where the mainspring collet goes; *k* the lower bearing; *l* where the stop work goes. After the arbor is placed on the chuck as shown in fig. 2, and held in position with just lathe wax enough to ensure stability, the teeth of the ratchet should be turned off down to about the line *h*, fig. 3. At diagram *F** is shown a section of the new ratchet wheel to be fitted on to the old winding arbor. The old ratchet wheel should be reduced by turning a little more than one-half in thickness, and the new ratchet wheel should also be a trifle thicker than the old one. It is evident that the object to be attained is to unite the new wheel to the old arbor in the most secure manner possible, consistent with the economy of time. The hole in the new ratchet wheel shown at *m*, diagram *E**, should exactly fit the square *c*. When turning away the upper portion of the old ratchet wheel to be occupied by the new one, of course it is essential that the turning

should only extend inward to the circle *o*, diagram *G**; this diagram is a view as if seen in the direction of the arrow *p*, fig. 3. It is evident that the dotted line *g*, diagram *H**, is the upper face of old ratchet and we have turned away the upper face and left *o*, diagrams *G** and *H**. This part *o* must now be filed square to correspond to the old winding square *c*, so that the new ratchet wheel and the part of the old ratchet remaining will come in the position shown in diagram *F** and *H**. The old ratchet should be turned off to about the size shown at the dotted line *u* shown in fig. 3, and diagram *F** and *H**. In doing this job it is essential that enough of the old ratchet should remain to hold the arbor rigidly upright, and also that the new wheel should have thickness enough to hold securely on the square at *o*. In turning the recess in the new ratchet wheel it can be cemented to a face plate and turned out as shown at *F**. It is important that all the parts in this job should be left as hard as possible consistent with strength. Generally the old arbor will be soft enough to turn, if not it should be softened only enough so it is barely possible to turn it. The ratchet can be made quite soft and turned and fitted, when it should be rehardened and tempered. It should be left quite hard, that is, reduced to a light brown or dark straw. It is a fact worth knowing that steel hardened and reduced to this temperature (before any violaceous cast sets in) is the strongest to resist strain that it ever will be, or at the point of its greatest rigidity. It is an excellent plan to soften the whole arbor, even when filing up the teeth, and then after the work is all done, to protect the arbor with some anti-sealing compound and heat and rearden, reducing the temper to the point recommended above. As the parts have been protected from scale a very little polishing will restore the finish. There is hardly any job a watchmaker is called on to do which demands a greater exercise of judgment than this very simple one of *jumping* on a new ratchet wheel to an old arbor. In selecting a new wheel, it is well to choose one which is a mere trifle larger than the old one; and in turning the recess shown at *v*, diagram *F**, not quite half the thickness should be removed, as a quite thin collar on the arbor *c*, fig. 3, will keep the arbor upright. Another feature is important, and this is the old ratchet wheel, when reduced to the proper size to fill the recess at *v*, diagram *F**, should fill this recess a little more than flush, as shown at *v*, diagram *H**; this serves to keep the old and new ratchets pressed together when the ratchet cover is screwed down. In selecting a ratchet, the teeth should neither be too fine or too coarse, but a medium number of teeth, say about 30. In turning in a new arbor, the wax chuck will generally answer better than the split chucks, as the unfinished arbors are generally squared for the keys, and the split chuck hardly ever holds the square true; so, commence by putting the square into the wax, and turn and fit all the lower bearings, bridge, top barrel bearing, lower barrel bearing, stop work, before the arbor is removed from the wax. The part which extends below where the stop wheel goes should not be cut off, but the hole for the pin should be drilled, leaving the conical point or termination of the arbor to secure your center, if you reverse ends in the wax. If the upper end is squared, as it usually is, the only object in reversing is to file off the upper end of the winding square flat and polish it. Consequently the reader will see that it is hardly necessary to reverse in the wax, so he can file off the lower end in the first operation, and finish the top in a split chuck or a screw head tool.

Gold and Silver—their Elaboration.

(Continued from Page 142.)

THE CLEANED articles, which are to be gilt, are, with thin zinc wire, hung to a thicker one, and plunged into the hot gilding bath. This latter, prepared according to the preceding recipe, contains oxide of gold and potash, and the gold is precipitated upon the articles in the form of a lustrous deposit.

REGNAULT'S GILDING FLUID.

100 g. gold are dissolved in a mixture of 250 g. nitric acid, 250 g. muriatic acid, and 250 g. water, after which 3 kg. bicarbonate of potash are added to the clear solution. The latter must only be added gradually, since the fluid effervesces strongly in consequence of the escaping of the carbonic acid. The fluid is next poured into an iron kettle, containing 20 liters boiling water; the gilding bath is ready, after having been boiled for two hours and the evaporating water replaced.

The articles, pickled bright in the ordinary manner, are, after rinsing, dipped into quickening water, to facilitate the more rapid formation of a mercury coating, then secured to a brass wire, dipped for 30 to 60 seconds into the hot gilding bath, rinsed, and dried. If the gold coating of the articles is desired to be thicker, they are not fastened to brass, but zinc wires, and immersed into the fluid; zinc promotes a more powerful precipitation of the gold, on account of the stronger electric current it generates in contact with silver or bronze.

To acid-color the articles gilt in this manner, a concentrated boiling solution of six parts saltpeter, two parts sulphate of iron, and one part sulphate of zinc is prepared, the articles are plunged in it, and heated over a coal fire until the coating has become brown, when they are washed off and dried. Owing to the extreme thinness of the gold film precipitated upon the articles, the subsequent brushing must be very carefully performed.

ELSNER'S METHOD OF GILDING.

One part chloride of gold, prepared according to the prescription given in the beginning of this article, 5 parts culinary salt and 5 parts yellow prussiate of potash are dissolved in 50 parts boiling water, the articles plunged into the fluid, and touched with a piece of zinc. Gilding is effected in from two to three minutes, and the articles made lustrous by rubbing with cream of tartar powder and water.

COLD GILDING.

A fluid is prepared for this, produced by dissolving chloride of gold in water, and adding about one hundred-fold the quantity by weight of the chloride of carbonate of potash. The articles, united with a piece of zinc, are dipped into fluid and withdrawn after a few minutes.

To gild steel in the cold way, crystalized chloride of gold is dissolved in very little water, a quantity of ether amounting to four-fold the volume of water is added and well shaken. The fluid is, after a few hours, applied with a hair brush upon the steel, the gilding washed with water, dried with cotton or blotting paper, and polished.

GILDING BY RUBBING.

A linen rag is saturated with a solution of gold alloyed with copper, dissolved in nitro-muriatic acid, dried, and burned; the remaining ashes contain metallic gold in finest division, which ashes are firmly rubbed upon the article to be gilt with a cork dipped in salt water or nitric acid.

A somewhat better adhering rubbing mass is obtained by dissolving chloride of gold in a solution of cyanide of potassium, adding sufficient washed chalk until a paste ensues, which is applied with a hair brush or piece of kid glove.

This kind of gilding is applicable only in places where articles that are not subject to being handled are to have a gold-like appearance; it is of very inferior service for buttons, and articles in general, subject to much wear.

B.—SILVERING.

Silvering may be performed in a similar manner with gilding, either hot or cold fluids may be used, or it may be rubbed on. Especially the first method is pretty extensively used, aside from silver-plating by the electro-chemical method, while the other processes are employed by instrument makers for silvering the scales of thermometers, etc., as well as by bronze manufacturers.

SILVERING BY BOILING.

A durable silvering is produced by dissolving six parts each of

cream of tartar and culinary salt in water, heating to boiling, and adding to the fluid freshly precipitated chloride of silver (one part); after the latter has dissolved, the article to be silvered is placed into the boiling hot bath, and connected with a piece of zinc corresponding to the size of the article. The galvanic current, produced in this manner, effects the rapid precipitation of a uniformly thick coating of silver, almost as handsome as one effected by the electro-chemical method.

The articles may also be silvered in this bath without any contact with zinc; in this case from fifteen to twenty minutes will be necessary, while the work is finished in less than half the time by the former process.

In place of the above specified silvering fluid, also that employed for the electro-chemical silvering may be used, that is, a solution of cyanide of silver and potassium, at the same time making use of the contact operation with zinc. This kind of silvering is actually the same as that produced in the electro-chemical method; the only difference exists in that by the latter process the electric current is produced by a special source of electricity, while with the above mentioned method the galvanic element is produced by the two metals themselves.

Although the silvering becomes handsome and uniform, still it is of a mat luster; if a special gray surface is desired, the so-called luster, the articles are immediately placed from one silvering bath into another one, in which a solution of 10 parts of hyposulphite of soda in 50 parts of water has previously been dissolved and heated to a temperature of 70° to 80°. Sulphuret of lead precipitates hereby upon the article, whereby the article becomes of an agreeably gray color.

In order to resilver old silver-plated articles, the coating of which has worn off in certain places; without desilvering and resilvering the article, the following process, similar to boiling, may be employed:

A cyanide of silver solution of a considerable concentration, and heated to 80° or 90°, as well as a vessel with very fine zinc-filing, is kept in readiness. The place to be silvered is brightened with soda lye and sulphuric acid, a small and soft brush is dipped into the cyanide of silver and potassium solution and applied to the surface to be silvered; zinc powder is next strewn upon it and divided with the brush. A very handsome silvering ensues at once, which can be thickened by repeating the entire operation. After finishing the work, the silvered zinc filings are rinsed off and preserved, to be used again at a future time.

Copper, brass, bronze, German silver, and all nickel alloys can be silvered by this process. Iron and steel, however, must previously be coppered, which is done by pickling them bright, dipping into a solution of sulphate of copper, taking out in a few seconds, after which they are rinsed with water and silvered; the copper coating need not be thicker than simply to cover the iron; thicker copper coatings, in case they are not produced the galvanic way, would even be injurious, as they do not adhere firmly upon the iron.

If the operator has carbonate of silver on hand, a silvering fluid can quickly be produced by adding carbonate of silver (the process of manufacturing of which has been explained at the beginning of this work) into a hot solution of cyanide of potassium, until it ceases to dissolve in the fluid, heating the solution, and plunging in the article to be silvered, which is either connected with a piece of zinc or simply wrapped with zinc wire.

COLD SILVERING.

For producing a silvering in the cold way, a strongly diluted solution of nitrate of silver in the proportion of at least 50 to 60 parts water to one part solid nitrate of silver is prepared; the more diluted the fluid, the slower the coating is precipitated, but the more durable it becomes.

If the pickled and brightened articles are wrapped around with zinc wire and suspended or placed in the fluid, the precipitation of the silver, in consequence of the contact, ensues quicker. The silver

coating forming at first is very thin, but, when the bath is kept at a uniform strength by occasionally adding a small quantity of a more concentrated solution, the coating will soon increase in thickness. The well-rinsed article is afterward polished with washed chalk and next with bloodstone.

A more durable silvering is obtained by dissolving 1 part chloride of silver in 8 parts caustic ammonia, which solution is boiled for 15 minutes in a porcelain dish with another one of 5 parts cyanide of potassium, 5 parts crystallized soda and 2 parts culinary salt in 144 parts distilled water, and the fluid filtered.

BÖTTGER'S SILVERING FLUID.

Hyposulphite of silver is used for this silvering fluid, prepared by adding ammonia to a solution of nitrate of silver, until the precipitate arising at first is dissolved again, after which the fluid is mixed with a concentrated solution of hyposulphite of soda in water. An addition of alcohol causes a precipitate of hyposulphite of silver out of the fluid.

Owing to its extreme tendency to decompose, the silvering fluid is to be prepared only immediately before use, by dissolving the hyposulphite of silver in ammonia. Copper and brass, as well as iron and steel, can, by means of this fluid, be silvered directly.

The hyposulphite of soda is universally used in photography, and can be had in commerce at a low price.

SILVERING BY RUBBING.

This kind of silvering, generally of little durability, is performed in different manners, and various silver preparations may be employed.

For instance, if equal parts of chloride of silver and culinary salt are mixed with sixfold their quantity of washed chalk, a silvering powder is obtained that needs simply be rubbed strongly upon the bright polished metal, by means of a piece of leather, whereby it becomes very handsomely silvered. Cheap buttons of a white alloy can in this manner be given a really handsome appearance—for a few days.

Another silvering, of a somewhat greater durability, is prepared by mixing chemically prepared silver powder (its method of manufacture was explained at the beginning of this writing under the head "chemically pure silver") with double the weight of cream of tartar and culinary salt, carefully dried and finely pulverized. To employ it for silvering the necessary quantity of the silvering powder is moistened with a little water, and the paste strongly rubbed on the article to be silvered, which hereupon assumes a handsome lustrous grained coat.

The "silvering fluids," contained in black bottles, occurring in commerce, generally consist of a more or less concentrated solution of cyanide of silver and potassium.

XXIV.

THE WORKING OF WASTAGE IN GOLD AND SILVERWARE FACTORIES.

A quantity of wastage of the precious metals occurs daily in a gold and silverware factory, in form of sheet clippings, pieces of wire, scraping from soldered pieces, filing dust, etc., which not alone cover the workbench but also collect in the shape of fine dust upon the workshop floors. Since these wastages cannot be considered as total loss, factories collect the sweepings, and when a sufficient quantity is together the gold and silver is worked out of them.

In a like manner the wash water used by the workmen for washing their hands on the conclusion of work is also collected and poured into a larger vat. The fluid, which has generally clarified and settled after one day's standing, is drawn off from the sediment, in which the gold and silver is found.

When the residues are to be worked up, the sediment is taken out of the vat, placed upon cloths, suspended by their four corners, and permitted to dry; the powder form residue is then worked together with the sweepings. This residue of the wash waters contains, beside the metals, also lime soap and organic substances; the sweepings are charged with large quantities of both organic and mineral

dust, as well as other metals contained in the alloys and solders, therefore, gold, silver, copper, cadmium, zinc, iron, and sometimes tin.

The operation is begun with bringing coals to glow heat in a draught furnace, which is provided with a pretty deep groove, and a grate below this. A part of the sweepings or the wash water residue is thrown upon the coals, the organic substance burned, fresh coals are supplied, if necessary, and this operation continued until all sweepings are burned.

The ashes collecting under the grate now contains all the gold and silver contained in the dust in a metallic state. These ashes are placed in a tub, provided with a tap-hole at about one-fourth its height, closed by a stop cock; water is poured over the former, well stirred, and the fluid permitted to clarify for a few minutes, after which it is drawn off.

While the densest metals, such as gold, silver, copper, etc., precipitate quickly, the lighter particles of the ashes remain suspended in the fluid, and are drawn off by way of the faucet. This washing is repeated once or twice, the heavy powder found upon the bottom is placed upon the cloths and dried.

The dried powder is mixed with calcined borax to about five per cent. of its weight, and smelted in a plumbago crucible; in case that the quantity should be too large to be smelted at once, a portion is treated at first, and when fused, more is added, until the entire quantity has been fused.

The contents of the crucible is slowly poured through a broom into a larger flat dish filled with water, which is kept in motion by being stirred; at the bottom of the dish metallic grains will be found, which are an alloy of all metals contained in the sweepings.

The next step is to separate the gold and silver from this alloy. The grains are for this purpose placed into a porcelain dish of appropriate size, standing in a larger porcelain or stoneware dish, and the space between the two is filled out with fine sand; the outer vessel is for the purpose of guard in case the inner one should burst.

The vessels, standing upon a tripod, are placed into a draught furnace, the metallic grains poured over with strong sulphuric acid, and the vessels heated by coal fire, until sulphurous acid begins to develop in air, after which the fire is moderated sufficiently so that the fluid does not foam up too strongly.

As soon as the development of sulphurous acid slackens, small portions of sulphuric acid are added, and stirred in the vessel with a glass rod. When no more grains can be felt with the latter, and no more sulphurous acid evolves, after adding another portion of sulphuric acid and heating, the operation is ended.

The mass cooled in the dish forms a crystalline paste, consisting of sulphate of silver, sulphate of copper, etc., and incloses the finely divided gold. The paste is placed into a larger vessel with water, and stirred well. The sulphate salts of the oxides of copper, zinc and cadmium, and a little of the hardly soluble sulphate of silver dissolve hereby. The fluid is decanted, the crystalline mass again treated with water, and a sheet of copper placed into the united wash waters, which precipitates the silver chemically pure.

The crystalline paste now contains only sulphate of silver and metallic gold. Soda lye is poured over it and boiled in a porcelain dish. The sulphate of silver is decomposed hereby, and an easily soluble sulphate of soda and hydroxide of silver is produced.

The fluid, after having been boiled for fifteen minutes, is poured off, the powder washed with distilled water, and nitric acid is poured over it. The oxide of silver dissolves completely to nitrate of silver, the solution is filtered, and chemically pure silver may be precipitated out of the solution by placing in a sheet of copper; the gold remains upon the filter in form of a peculiar gold brown powder, in which it appears in condition of minute division, after the solution of nitrate of silver has been dripped off, and is either worked into gold preparations by dissolving in *aqua regia*, or fused to a button with a little borax.

[THE END.]

The Easing of the Anchor Pivots.

[PENDULUM GUIDANCE OF LOUIS STRASSER, IN *Journ. d. Uhrm.*]

WE REPRODUCE the following pendulum guidance from above journal, deeming it to be of a superior construction; it is rendering excellent services in practice, being adopted for astronomical clocks, constructed in the factory of a large German firm.

The reader will see that its construction is very simple; fig. 1 represents the upper, fig. 2 the front view. A movable piece of brass is fastened by screw *r* upon pendulum rod *a*; through this piece passes screw *c*, which is provided on both ends with pivots, upon which sit milled heads *e* and *g*. Frame *v b w n* moves with ease around the

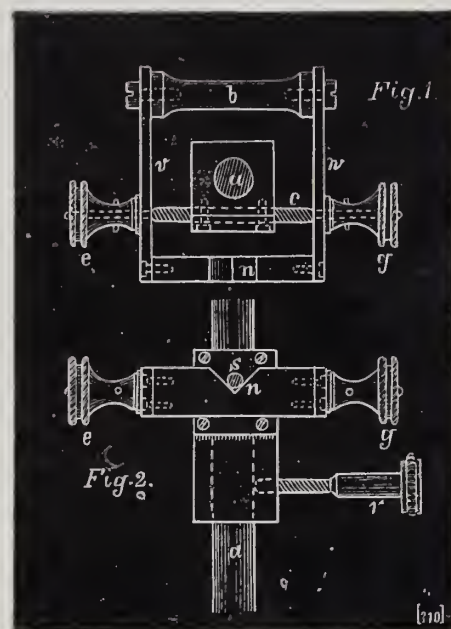

pivots of screw *c*; the part at *b* is longer and heavier, and, therefore, presses front part *n* up. A three-cornered cut is situated at this part, in which rests the fork pin without shake, while part *n* is easily pressed up, by which arrangement the anchor pivots are eased from the weight of the fork. The fork can be of a slight construction, since it has only to carry below the guiding pin *s*. The drop can very easily be regulated, simply by moving screw *c*.

Saunier points out this construction in his great work on horology, we believe, page 367, giving a similar cut, although leaving out the minor details of construction.

Table Utensils.

[BY JOHN W. MILES.]

IF "SELF-PRESERVATION is the first law of Nature," and eating is the first law of self-preservation, then such implements as may be used for this purpose of life assume a more considerable importance than is usually given them. It goes without saying that the knife, spoon and fork in use at the present day did not spring into existence in a single decade, or even a single century. The development of these articles has been remarkably slow, and in some particulars characterized by extreme opposition, not only of the people but even of that more intelligent class of society—the clergy. The archæological and historical study of this development, from the dark disputable records of prehistoric times through ages of constantly increasing light up to the present day, is of a very extensive character. It is not possible in a single paper to give more than a faint outline of the changes that have been effected during these centuries of time. One must, perforce, write as a bird flies, momentarily resting, here upon a rock, there upon a monument, entirely omitting much of the intervening spaces in order to present a full though imperfect view of the whole. Considerable extraneous matter concerning the different

epochs must also find space in treating of articles so intimately connected with the daily lives and habits of the people, for any historical record of the table utensils of different ages must necessarily give some account of the food, the manners and the sentiments of those who used them. If, therefore, it may appear in the succeeding pages that the writer does not always cling closely to his subject, it will be because some explanation of these matters are requisite to a proper understanding of the immediate topic, and also the difficulty, in a restricted essay, of selecting from a great mass of facts and illustrations such as may prove the most prominent and appropriate. I need not add that in a sketch of this character I am under obligations of the most varied kind to others.

If the Chinese historians are to be trusted, that nation is not only the oldest extant but also the oldest known to history. Whether we acknowledge such great antiquity or not, it is certainly proper that they should be classed among the ancients, and duly, if only briefly, recognized in the consideration of early habits and customs. In this connection we are met at the outset with the fact that the Chinese have been for ages an unprogressive nation, and we are compelled to assume, in the absence of positive information, that the articles which served them in their earliest history were the same as those in present use. The recent limited intercourse with other nations, while it may have modified or amended many other things, has had little or no influence upon their gastronomical customs, and the modern Chinese table cannot be greatly different from those of the unknown ancient times. Rice forms their principal food, and where, among the better class, meat is used, it is almost invariably cooked by boiling, and hence served in a condition more or less fragmentary. They are thus able to dispense with the knife, which is rarely seen upon the table. The curious sticks, nine or ten inches long, which are employed for conveying the food to the mouth, are used by them with great dexterity. They are held in the right hand between the thumb and first finger, as in figure 1, and in this position they are so fully under the control of an experienced manipulator that the finest needle can be picked up and firmly held with them.

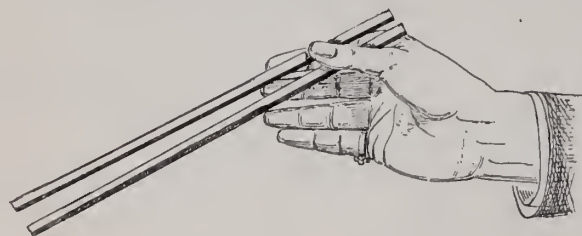

FIG. 1.

Very young children, even, acquire such skill that they are able to remove the smallest bones of a fish with great facility. The common "sticks" are made of bamboo, but for the better class ebony or ivory is used. Rice is served in bowls, which are held to the mouth, and the contents urged in with the sticks. When the mouth is full the rice is swallowed with little or no mastication. Plates for each individual are not used, the meats and other viands being served in a single dish from which all partake directly. These dishes in common are never removed from the table in the presence of the guest, but as fast as one is emptied another is placed at its side. They are of different shapes, adapted to form fanciful figures upon the table; each course, as it is brought on, adding something to the general design. Spoons also are used by them in eating liquids. They are about four inches long, made of porcelain and decorated with painted flowers, birds and other Chinese devices. The handle is short with a shallow channel running the entire length of the upper surface and widening into the bowl, figure 2.

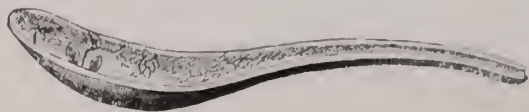

FIG. 2.

The Chinese invariably bathe their hands and face after a meal and

often between the courses, at which time they usually retire to another room to drink tea and smoke opium, returning again to the table for the next course. It does not appear that these frequent ablutions are necessary, as, although the use of forks is utterly unknown to them, the chop-sticks answer the same purpose, and, therefore, their hands seldom if ever come in contact with the food.

The field of improvement in articles for the table lies principally in European countries, and it is among those nations that we find the progressive innovations and inventions that gradually developed into the articles of to-day. That the knife is the most ancient we may well conceive. The primeval man dwelling in caves and dependent in a great measure for his sustenance upon his prowess as a hunter, required something besides his hands, for not only killing, but also for dressing and eating his food. The first implements of this nature were extremely crude, and were probably used for all purposes for which a knife is necessary, but as man multiplied upon the face of the earth, knives were constructed of different forms and sizes, for war, for the chase and for domestic use. Immediately succeeding the glacial period came what has been termed the "stone age," traces of which exist in almost every country of the world. The richest store of articles belonging to this highly prehistoric epoch are found, not in the classical countries of Greece and Italy, but in that portion of northern Europe which comprised the ancient Scandinavia. The age of stone in all its primitive purity extended in those parts to a much later date than at any other point except America. The different customs of the early stone age are either wholly unknown or veiled in the obscurity of mere conjectures, based upon the character of such articles as may have survived the ravages of time. The remains discovered in the drift gravels, shell mounds and coast finds include a large number of implements and weapons, principally of silix or flint, and some few pieces of wood, horn and bone. No traces are found of any metal except gold, which was sometimes used for ornaments. Among the stone axes, hatchets, arrow and spear heads, occur numerous flint flakes roughly formed, which were used for knives, (figures 3 and 4).



FIG. 3.



FIG. 4.



FIG. 5.

These were chipped from loose blocks of flint found scattered over the surface of the ground, which, having been exposed to the sun and air, were naturally more brittle than the flint cones afterwards mined from the native beds in the earth. Consequently none of the stone implements were at first polished, although some of them were fashioned with great labor. For instance, the holes in the axes for receiving the wooden handle bear evidence of being made entirely by friction—an upright stick being rolled between the hands in a manner similar to the savage method of producing fire, while sand and water was applied at the end resting upon the stone. The discoveries that have been made in the tumuli, or burial places, are more highly finished than those of the drifts of coast finds, and hence have been ascribed to a later period of the same age (figure 5). Among the Lake Dwellers of Switzerland these polished knives were set into

wooden handles and secured by means of bitumen. Such knowledge as we possess regarding the manufacture of stone knives is derived from America, in which country, as has been stated, the stone age extended to a very late period. At the invasion of Mexico by Cortez in 1519, he found the Aztecs, although acquainted with bronze, still using knives of stone, and Torquemada has given us an account of the process of manufacture as follows:

"They had and still have workmen who make knives of a certain black stone or flint (obsidian), which it is a most wonderful and admirable thing to see them make out of the stone; and for the ingenuity which invented this art is much to be praised. They are made and got out of the stone (if one can explain it) in this manner: One of their Indian workmen sits down upon the ground and takes a piece of this black stone, which is like jet and as hard as flint, and is a stone which might be called precious, more beautiful and brilliant than alabaster or jasper, so much so that of it are made tablets and mirrors. The piece they take is about eight inches long, or rather more, and as thick as one's leg or rather less and cylindrical. They have a stick as large as the shaft of a lance, and three cubits or rather more in length, and at the end of it they fasten firmly another piece of wood eight inches long to give more weight to this part. Then pressing their naked feet together, they hold the stone as with a pair of pincers or the vise of a carpenter's bench. They take the stick, which is cut off smooth at the end, with both hands, and set it well home against the edge of the front of the stone, which also is cut smooth in that part, and then they press it against their breast and with the force of the pressure there flies off a knife with its point and edge on each side, as neatly as if one were to make them of a turnip with a sharp knife or of iron in the fire. Then they sharpen it on a stone, using a hone to give it a very fine edge, and in a very short time these workmen will make more than twenty knives in the aforesaid manner."

The obsidian flakes of the Aztecs resemble the flint flakes of Europe in that the fracture is nearly the same and the latter were probably made by pressure also; either by this or some other process. That these instruments were used by the aboriginal man with greater facility than we imagine is proven by those savage tribes who still use flint knives, and are able to cut up with them large beasts like giraffes and rhinoceroses, a feat attended with considerable difficulty even with the finest steel knives of European manufacture. Among the North American Indians the knives were "rudely made of obsidian, and sometimes fastened in handles of wood or horn." Adolph Decker, who visited Polynesia in the early part of the 17th century (1624), said that the Fuegians, among other implements of wood, bone and stone, had "stone knives which are very sharp." The wonderful houses and canoes of the South Sea Islanders were built with stone tools, and among the Tahitians, when first discovered, stone was used as well as bone, shell and wood. Iron was entirely unknown to the latter, and they at first mistook nails for the young shoots of some hard wood, and planted a number of them in their gardens, hoping they would sprout and grow. The Australian knives were of wood, pointed at one end, and with a few splinters of quartz or flint arranged in a row and stuck on with gum. The Fijians had knives made of pieces of bamboo shaped into form while green. After drying they were charred, and thus became very hard and sharp. The knife used by Abraham in the biblical account of the attempted sacrifice of Isaac was of flint, and flint knives were used by the Israelites for circumcision up to the time of the Exodus. The Egyptians also who practiced the same ceremony used knives of stone for the purpose.

There is no record of flint knives being set apart and exclusively used for eating, nor were they used at the table at all, except in cases of absolute necessity. The table customs of that remote period were not fettered by rules of etiquette, and among the Celtic nation, surely, it does not seem that the people were particular either as regards their eating or the manner of it. Posidonius said of them: "They eat in a very slovenly manner, and seize with their hands, like lions with

their claws, whole quarters of meat, which they tear in pieces with their teeth. If they find a tough morsel they cut it with a small knife which they always carry in a sheath at their side." It would appear, therefore, that the knives used in eating served also for fighting or for any other purpose requiring such an instrument, and in order that the edge might not become blunted they were carried in a sheath.

These crude utensils were followed by those of copper, which was the first metal that became of real importance to man. The period of the use of pure copper was comparatively limited, or else such as may have been formed into articles of use were subsequently melted up for the alloys of a succeeding age. Certainly the remains of these ancient races contain very few specimens of this metal. Lubbock suggests the theory that when metals were very scarce it would naturally happen that in order to make up the needed quantity some tin would be added to copper or *vice versa*. This alloy, in proper proportions, would produce bronze, and inaugurate the "bronze age." Upon the discovery of bronze it appears to have been used for all objects previously made of stone. It is found in the tumuli of the later stone age together with flint implements, and it is believed that at the beginning it was too expensive for the poorer people, who were thus compelled to use the earlier material. The weapons of the Homeric age were of bronze, and this metal was held in superstitious veneration by the Romans. Following as closely as possible, in the dim uncertain light of the times, the chronological order of the subject, we present illustrations of a bronze knife from the remains of the Swiss Lake Dwellers, figure 6, and four from Danish tumuli, figures 7, 8, 9 and 10.



FIG. 6.



FIG. 7.



FIG. 8.



FIG. 9.

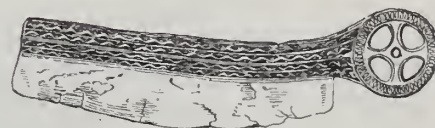

FIG. 10.

All of these display a considerable amount of decoration, particularly those from Denmark, one of which, figure 9, has a leather case or sheath. The bronze knives of Switzerland were fitted with handles of bone, horn or wood, and, like some from Denmark, the blades were peculiarly curved, possibly to increase their strength, on the principle of the arch. These knives strikingly illustrate the natural

aspirations of humanity for the ornamental in design. That an age so early should have produced not only modelled figures but also engraved lines, and solely in the pursuit of decoration, is indeed wonderful.

(To be Continued.)

The Cylinder Escapement.

[BY HERMAN SIEVERT.]

Continued from Page 137.

The curb-pins are to be closed by a revolvable regulator, to prevent the balance spring from leaving the space between the pins, or jump between them with one or more coils, in consequence of strong jars. The key generally fulfills the functions of the outer pin, but in this case it must also possess all the properties of such a one; that is, as small a face as possible, running parallel with the other one, together with an undoubted solidity. It is necessary to free the holes from burr and sharp corners, so that the pin and key are located firmly. A smaller diameter of the spring may necessitate a different position of the pin. The regulator key must be very smooth on the lower face, and not protrude beyond the pin, to prevent the second coil of the spring from hooking thereto. Pay particular attention that the springs do not rub on the bottom of the key, since it produces a great loss of power; the key, therefore, must be sufficiently high. It is best, when renewing a pin and key, to ascertain its height while the cylinder, after correcting the escapement, is still in the watch. For this purpose the shank of the balance is brought under the regulator, which need simply be held with the finger upon the bridge. Sufficient is then removed from the newly inserted curb pin so that space remains for the key. This is then made according to the height of the pin.

The dial must offer sufficient freedom for the unconfined motion of the hands and their staffs. The holes must not be enlarged by broaching, but by filing, after the edge of the enamel has been carefully removed with a sharp graver. The dial must be securely fastened; the bending of the copper feet for this purpose is not permissible. If the screws are still good, the remedy, if the case is very bad, is to fill the feet that were filed out too wide with tin. A thread will be cut into the soft metal by the turning of the screws. The dial is not disfigured by well proportioned screws if located in proper positions. The drilling of the dial is done with oil of turpentine or petroleum. A loose dial frequently occasions the standing of the watch in the pocket, because it bears against the second hand in certain positions.

For mounting a new dial smooth card-board is used, with which the holes for the feet and hands, as well as the correct position, is transported upon the watch plate.

REPLACING DIFFERENT PARTS.

The description of a few special jobs only remains, which are necessary for replacing single parts; and I will begin with a few remarks on

SCREWS.

Never permit a loose screw to remain in a watch, since it might loosen and do great damage. Do not be over anxious to dispose of your screws, purchased at the material dealer, and to force them into any hole, no matter whether the thread fits or not. The forcing in of non-fitting screws is botchwork and betrays the careless workman. Besides this, the search for a suitable screw consumes almost as much time as a diligent workman uses in making a new one. Always bestow the necessary care upon the thread in the hole, so that, for instance, you draw the temper from a regulator plate, in order to correct the holes, should the thread in them be bad. Before you separate the screw-head, after having cut the thread, try the screw first in the hole for which it is intended, and correct it,

until it enters easily. Both filth and dust must be carefully removed for this purpose. It is offensive to the eye of the expert, and frequently to that of the layman, if the bridge screws have been left in an unfinished and soft condition. Should the remuneration not permit a careful polish, a clean surface, given with an emery file, should at least be produced in the screw-head polishing tool. Such a screw-head, well executed, will always look passably well. A screw, annealed only once, is too hard and breaks easily, wherefore make it white again, after the first hardening and annealing, and then give it the necessary color.

TURNING-IN PINIONS.

The gauging is the chief thing for all work that exacts true proportions of dimensions. I do not mean hereby the exact imitation of an article before you, but the ascertaining of the most suitable proportions by the space at disposal and the nature of the object. For this purpose I can recommend no better tool than the Glas-hütte decimal gauge. It is divided according to the metric system, and gotten up so exactly that it permits the calculation of all lengths without danger of inexactness.

To explain to you the measuring by this gauge, let us choose as illustration the turning-in of a center pinion in an ordinarily constructed watch, in which the wheel is a little below the surface of the plate. We mount the center wheel and center bridge. Let us suppose that as much is lost by the rounding of the pivots as the depth of the oil sinks amounts to. We measure from the lower side of the plate to the upper face of the mounted bridge, and find 5.2 mm. as total length of the pinion together with the center points. The thickness of the plate at the lower hole is 0.5 mm., that of the bridge at the same place 0.55 mm. The end shake must be at least 0.15 mm., and 4 mm. remain for length of arbor. The distance from the lower side of the plate to the upper face of the center wheel pressed up is 4.3 mm., as the necessary length from the face to the lower end of the pinion together with pivot point. So as to work very exact we also measure the distance of the upper side of the fourth wheel from the underside of the plate, after we have placed a piece of wood under the wheel, and obtain 1.2 mm.; the thickness of the entire plate is 2.4 mm., consequently 1.2 mm. remain for the distance of the fourth wheel from the upper side of the plate. We divide this space for the height of the center wheel. It is 0.3 mm. thick; it may, therefore, remain 0.3 mm. below the surface of the plate, because 0.6 mm. is plenty as space between the two wheels. From the surface of the plate as far as the face is $4.3 - 2.4 = 1.9$ mm. Hereto the 0.3 mm. which the wheel is to remain below the plate surface, gives 2.2 mm. as the length of the pinion from the face to the shoulder of the wheel. These measures are taken and noted down in a shorter time than it takes to read these lines, and make any further trying and fitting-in superfluous.

By the further use of the decimal gauge a small screw for fastening the index is very useful. Place the former at 4.3 mm., and shorten the lower pinion arbor. All gauging, of course, must take place from the ready face. Now fasten a turning dog upon the upper pinion arbor, push the other end through a conical hole of the turning tool center, if possible as far as the wheel shoulder, and turn on the center, do not, however, shorten the arbor thereby. Next place the gauge at 5.2 mm., in the same manner shorten also the upper arbor, and turn on the center, while the face revolves in the conical hole. If this is right smooth the injury to the extreme points of the face will be so insignificant that it can hardly be noticed with the magnifier, and, at any rate, is uninjurious. The pinion will now run so exact and true as is not easy to attain by the filing of the points. Now mount the pinion upon a brass screw collet or cement collet, in place of the turning dog, the screw of which might ruin the pinion, and turn the shoulder for the wheel at the distance of 2.2 mm. from the face. The underturning is made only after the wheel has been driven with a few slight taps upon the gently tapering shoulder.

I have described this work as minutely as possible, and the turning-in of the fourth pinion is done in a like manner. The face of

the fourth pinion best runs up to the upper edge of the plate in case the center-wheel does not stand too high. It is not advisable, when turning-in a new pinion, to use the old one as pattern, since it might be unsuitable.

The decimal gauge does not reach as far as the center of the plate, and I will, therefore, indicate another means for measuring the center pinion, in case the old one is either lost or does not suit. We only need the length of the staff and pivot; the wheel is always taken as high as possible. Now, if we insert a smooth brass pin through both the holes we can easily mark the necessary height with the point of a sharp knife. The turning-in of the center pinion between centers is much more advantageous than upon the turning arbor, which by its small thickness only permits an insecure turning. The space for the center wheel is generally so contracted that the points of the under-turning may be at the same height with the pivot shoulder (fig. 22). These points will recede sufficient by the riveting of



FIG. 22.

THE TURNING-IN OF THE SCAPE PINION

is an extremely delicate and exact work. Since especially the height of the wheel in the cylinder cut must be determined very exactly, the old pinion, in case you know that it was correct in this respect, may be of essential service. But the pinion may get lost, or its gauging may not be appropriate for other reasons, and I will explain to you how the correct height may be ascertained by means of the decimal gauge. We must at first find out how deep the cap jewel plate is sunk into the bridge, because the cylinder will be shortened by this quantity. We lay a straight and uniformly thick piece of brass upon the upper side of the plate, so as to cover the turning-in for the scape wheel. This brass cover is now included in the measurement of the thickness of the watch plate, both within and near the sink to be measured. The difference between the two measurements is the depth of the sink. We now measure the cylinder from the pivot up to where the lower side of the wheel bottom is to pass through. It is not possible to measure direct this distance with exactness; we therefore proceed to measure from a commodious point, say about the upper edge of the balance spring shoulder, where the staff begins. Let us suppose that from there to the end of the lower pivot we have 4.5 mm., up to the place of the wheel bottom 3.1 mm., wherefore 1.4 mm. remain as the lower length of the cylinder as far as the place of the notch corresponding to the wheel bottom. Let us assume the depth of the sink for the cap jewel at 0.5 mm.; we add them to the above 1.4 mm., and obtain 1.9 mm. as the distance from the lower edge of the plate up to the shoulder for the escape wheel. From aforesaid lower edge we measure to the upper face of the jewel hole, and obtain 0.55. This latter gauging is sometimes possible only by aid of small plates laid upon the jewel, the thickness of which is to be deducted again. We now have $1.9 - 0.55 = 1.35$ mm. as the lower length of the pinion arbor as far as the wheel shoulder, which by the scape pinion is by far the most important measure, wherefore, it is to be determined with the greatest exactness. After we have screwed down the bridge, and laid a little under it for the sake of security, we measure above the two jewel holes, and deduct their thickness from the sum, in this manner obtaining the length of the arbor. The pinion is to be taken of about such a length that the oil will not flow into the pinion.

The turning begins after all the measures have been taken. The commercial scape pinions are generally far too long; since we would like to use the face, turn from the other end sufficiently away that only fully the length of the pinion with the shoulder remains. Now shorten the upper arbor to its correct length. Suppose the entire length of the arbor to be 2.1 mm., deduct from this, say, 0.25 mm. for the arbor below the pinion, and 1.85 mm. remains as far as the

face. The length of the pivot will have to be about three times its thickness, with the center point about 0.4 mm.; therefore the arbor is to be shortened at 2.25 mm. distance from the face. After the pivot has been polished and rounded off, and the wheel riveted, shorten also the lower arbor, let the pinion revolve in the conical hole of the turning tool center, and turn on the center. By this work, as well as by the turning-on and polishing of the pivot, use the wheel arms as followers instead of the turning dog.

The chief requisite for a good execution of this always difficult work is a firm and well arranged turning tool. If a wheel runs untrue over the teeth, the fault will generally be due to an untrue shoulder. Nicely turned-on centers will obviate this defect. If, furthermore, the measurements have been carefully taken, the wheel will also fit exactly.

MOUNTING A NEW ESCAPE WHEEL

upon a ready pinion is very easily done, since the hole is generally a trifle too small. Should the wheel be too hard for broaching the hole, make it a little softer in the center. For this purpose take a small wire pin, flatten the head about 3 mm. broad, and almost separate it, to lessen the conducting off of heat. Now glow-heat the head and apply it quickly to the bottom of the wheel, which will rapidly color. Grind the colored places with oil-stone powder, oil and wood, and whiten them again with oil-stone powder and elder pith. Then turn the cover down upon a turning arbor and make it as long as the old one, place the old wheel upon a broach and open the new one accordingly. The wheel must be driven firmly upon the pinion shoulder, but very cautiously, whereby it fits without riveting. Should the shoulder be untrue, of course it must previously be corrected. Also this work is not very difficult by aid of a safety roller if you do not neglect to have the silk thread very loose.

THE TURNING-IN OF A NEW CYLINDER.

For this work the gauge represented in fig. 23 is very useful. It only consists of a hardened screw 0.8 to 1 mm. thick, provided with so thin a pivot that it can enter into every jewel hole; *a* is a brass screw nut with a small index *b*. This index is the remainder of a

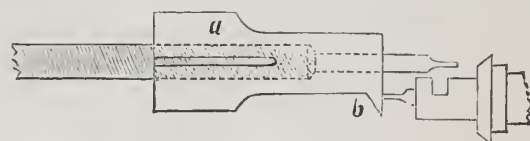

FIG. 23.

small turned-on disc, the other part of which has been filed away. The utensil is placed with the pivot in the lower cylinder jewel hole so that it rests upon the cap jewel while the screw nut is turned in such a manner that the index touches the scape wheel teeth. The figure furthermore shows the manner of using this tool for measuring the lower cylinder length. The engaging place for the wheel teeth must be there where the pivot end is located.

The cylinder which passes with only little shake between the wheel teeth must be chosen. It is still better to find the size of the cylinder from the measured diameter of the wheel. If the latter is multiplied by 0.119 the diameter of the exactly fitting cylinder is obtained. The correct height of the notches, according to the wheel thickness, is to be considered, and attention must be paid to that the entire length of the cylinder be sufficient for the height of the balance and spring shoulder.

The suitable cylinder having been found, separate the lower arbor with the nippers at about a correct length, and then shorten it carefully with a fine file, so that it suits exactly to the measure taken with the above utensil. You need not anticipate the breaking of the cylinder, held with your fingers, if you file toward the standing part from the cut, and if the file is not bad and coarse. Next fill the interior of the cylinder with cement and lack it upon a collet. Let the small tube of the cylinder run in an appropriate conical hole, and turn on the pivot point. Then measure the entire length of the cylinder, at first together with the low cap, and deduct the thickness of the cap jewel therefrom. Then shorten also the upper arbor and

turn the point on. The distance of the pivot point will afterwards govern the necessary end shake. Only the height of the balance now remains to be measured. If there is much room you may consider the balance as almost equal to the thickness of the watch plate, together with the mounted scape wheel bridge, the thickness of the cap jewel plate will then give the necessary interspace. But if the room is contracted by the center wheel, the exact indispensably necessary height is easily ascertained when both bridges are mounted in place. Then hold the cylinder reversed, the upper end turned down, with the corresponding shoulder upon the cylinder bridge, and turn the shoulder so far back that the upper end of the cylinder just remains free from the scape-wheel bridge. The shape of the shoulder see in plate II, fig. 3. As soon as the balance may, by a few gentle taps, be mounted upon the very exact and only gently tapering shoulder, remove the collet used as follower and place the cylinder into a fitting hole of the riveting tool, in order to firmly mount the balance by a few gentle taps upon a hole punch. But the balance must not fit too tight; it will easily sit sufficiently firm so as to use its arms as followers; the piece may be handled with more ease. Now follows the turning of the spring shoulder and the under-turning for the riveting of the balance. If the arbors are not long enough shorten the tube a little, but a sharp and clear under-turning must be made at finishing. A spear-shaped graver is very appropriate for this. Next turn the pivots about sufficiently thin and of that form called conical pivots, although this appellation is not correct, since only the shoulders are hollow-rounded. These pivots are protected far more efficiently against breaking than those with sharp shoulders. Only a square pivot polishing file is necessary for finishing them. It is easier to make these pivots than those with sharp corners, since by these latter the bevels are still to be turned, which is not necessary with the so-called conical pivots. This conical pivot must lie as far in the bearings of the pivot polishing tool as it is to be cylindric, and a gentle pressure has to be applied with the file against the arbor, so that also the rounding is handsomely polished. The ends of the cylinder pivots are to be made very flat, whereby the friction in lying and hanging is equalized. If the pivots are not too thick and the jewel holes right thin, the watch will preserve the same rate in either position, while with round pivot ends, thick pivots and thick jewel holes the watch will retard in hanging.

(To be continued.)

Watch Repairing.

THE YOUNG MIND horological will frequently have been puzzled to account for watches stopping and going again as soon as touched. The cause, should such a defect be found in a lever, is generally due to the banking pins being hardly wide enough to permit every tooth from escaping the pallet; and it being a well-known fact that most escape wheels are slightly out of round, this accident would occur on one tooth, and the bankings still might appear to be free, if tried for the rest of the teeth. Never bend the pins when correcting this defect, if they are already perpendicularly to the plate, but file just where the lever touches, and all the length, so that the escapement is not altered by the end shake.

If it occurs in a cylinder (horizontal) escapement, the defect is generally due to the pivots or holes of the escapement being worn, whereby the cylinder gets out of position and approaches the wheel slightly, so that when the tooth is inside the cylinder it touches both point and heel, pinches and stops. This occurs when there is only very little drop of the tooth in escaping; therefore, if the balance be moved so as to allow the teeth to escape, and they have very little drop, or if the teeth are unequal in length, and only one or two have but little drop, it is safe to conclude that the watch stops from this fault.

We may correct the defect in a two-fold manner; first, by replacing

the worn holes, and second, by taking off a little from the points of the teeth with a file, for which work much care is required, and it can only be done if circumstances do not permit the replacing of the holes. In the case of ordinary grade watches, the teeth of which are generally unequal in length, the proper remedy would be to make them equal in length; but the alteration of this length is utterly objectionable in a good watch, with escapement carefully proportioned, and new holes are the only proper remedy.

Improved Double Calipers.

ACCOMPANYING cut represents a double caliper, with spring points, in consequence of which the accidental breaking or bending of finer pivots is effectually prevented. The sketch is of natural size; the arms are somewhat shortened at *a a*, and bearings filed in, within which the two cylindric tubes *b b* are soldered; two points *c c* are ground into them truly exact. They are, at *d d*, provided with small holes, into which the ends of the two springs *e e*



protrude, so as to impart their elasticity to points *c c* in this manner, and, again, to prevent the falling out of the points; the caliper arms are provided with oblong holes at *g g*, to impart the necessary play to the springs; they are situated within the caliper, and are in no manner inconvenient in working.

The use of this caliper is very convenient, and its manipulation differs in no manner from the ordinary one. The articles, such as balance, wheels, etc., to be trued, are, with their arbors, slightly pinched between the points; if, however, the article is to be left to run free, an easy pressure upon one of the springs suffices. Above contrivance must be executed very carefully, however, so that the points *c c* do not wobble, otherwise the entire arrangement would be useless.—C. FIEDLER, *Allg. J. d. U.*

Sight.

WHAT THE OPTICIAN SHOULD KNOW ABOUT OPTICS.

Based upon an extensive hospital experience in Austria, Germany, England and New York. By C. A. BUCKLIN, M. D., New York. Author of *Detection and Correction of Visual Imperfections, Cause and Cure of Cross Eyes, Effects of Color on Distance, and Monograph on Astigmatism.*

Continued from page 150.

The following letter of inquiry has been received:

To the Editor of the Jewelers' Circular:

Noticing the articles on "Sight" in THE CIRCULAR I thought I would write you for a little information on the subject.

Is C. A. Bucklin's work on "Detection and Correction of Visual Imperfections, Cause and Cure of Cross Eyes, Effects of Color and Distance, and Monograph on Astigmatism," all one book, or is it in 3 or 4 volumes? Also, what is the expense of same? Do most jewelers succeed in fitting cylindrical lenses? Also, what will an assortment of test cylindrical lenses cost that will answer the purpose?

If you cannot answer questions please hand or direct to Dr. Bucklin, and oblige, Respectfully, W. H. B.

C. A. Bucklin's little work on the "Detection and Correction of Visual Imperfections" is a practical hand-book on the subject of optics, adapted to the use of all opticians who are of an enquiring turn of mind. Each one of the titles above mentioned are separate works. The "Detection and Correction of Visual Imperfections" is the only one which is of any practical value to the optician. It is sent, postpaid, for one dollar, by the Spencer Optical Company, 13 Maiden Lane, New York.

An intelligent jeweler can succeed in adjusting cylindrical lenses to simple cases of astigmatism, provided he will give the subject a little attention and follow the rules given in 'THE JEWELERS' CIRCULAR or in the "Detection and Correction of Visual Imperfections."

A collection of cylindrical lenses, containing twelve pairs of concave and twelve pairs of convex cylindrical lenses, can be manufactured for from eighteen to twenty dollars.

WILSON, KANS., June 8, 1883.

DR. C. A. BUCKLIN:

Sir—I have a patient whose case goes beyond my knowledge by far. He can see letters XXX at a distance of 23 inches, and XX at a distance of 14½ inches. A young man, 30 years old, was sick when about 18 years, which left him in his present condition. He cannot see across the street to discern any one; cannot see a house at a mile distant. I put up against the window-pane a sheet of brown paper, 2 feet square, into this I put a round hole, 1¾ inches in diameter; I directed him to look at the house one mile away, which he did not know was there; he did so and could not see anything when close to the paper, but when he stepped back as far as 5 feet 3 inches from the paper he was able to see the outlines of the house. I told him to come closer to the paper, and immediately the house became less distinct and farther away the same. I made the hole one inch in diameter, and at 5 feet 3 inches he could not see the house, but at 6 feet 4 inches he saw it as clear as at the first trial. I made the hole ¾ of an inch in diameter, and he was compelled to step back to 12 feet before he saw it. I lifted the paper and he could see nothing at all like he had seen; what he did see was nearer, and it was very indistinct. Can you do anything for him? What other facts do you desire to know? He is anxious to have a pair of spectacles so he can read without holding the paper as close as 4 inches from his eyes. He says some days vision seems clearer than at other times. Yours, E. Y. DOLLENMAYER.

P. S.—Convex and concave lenses seem to make no improvement at all.

The facts stated in the above letter appear rather difficult to explain.

If Mr. D. is thoroughly convinced that his patient sees the house in the manner he describes, then there is one of three explanations, only one of which is probable. He saw well until he was eighteen; at that time he lost his sight partially. This excludes any visual defect. There must have been some inflammatory disease. He probably had cerebral meningitis, which has damaged his optic nerves. If he fails to recognize promptly any of the colors *red*, *green*, *blue* or *yellow*, the above supposition is confirmed. You should always try your patients with *colors* when you find anything obscure about the case. Not finding color-blindness does not prove that meningitis is not the cause of the trouble.

You should next drop into the eye several drops of a solution of sulphate of atropia, containing one grain of the atropia and one-half ounce of water.

Observe if the pupil *dilates* regularly, and is perfectly round when dilated. Next place the patient in a dark room and focus with a convex lens No. 3 the rays of light from a lamp or candle which is situated two feet in front and two feet to the right for right eye, or two feet to the left for left eye, upon the dark pupil; if there is central opacity of lens or cornea you will see a gray spot in the dark pupil when the rays of light fall obliquely upon the eye.

We would like to hear from Mr. D. the results of these experiments. Would also like to know if the patient cannot see as well through a pin-hole in a card.

How to detect cataract in its early stages: The patient complains of seeing fixed black specks continually before his eye—by resorting to the atropia and lens as above described the optician may also see

some fine gray specks deep in the pupil. As the cataract becomes complete it looks like a round white spot deep in the pupil behind the iris.

When the person can no longer count fingers (with his back to the window) at more than one foot away, the cataract is sufficiently ripe to be removed. When he can count fingers at three or more feet, any attempt to remove the cataract is likely to be followed by unfortunate results. *Any person* under one hundred years of age who can see a candle-flame in a dark room at from eighteen to twenty feet, and can tell when you hold it *high*, *low*, and to the right or to the left, can be made to see again sufficiently well to read the daily papers.

I have discovered and published in *The New York Medical Record* a new method of curing many cases of squint. It consists in dropping into each eye twice a day a solution of the sulphate of *eserine*, ½ grain to three drachms of water. If this remedy be applied to the eyes of young children during the first few days they show symptoms of looking cross-eyed, the difficulty is frequently cured. The method is based on perfectly rational principles, and will be more fully explained at some future date. When this remedy is applied too late to produce the desired results, proper correction of the (hyperopia) far-sightedness with convex lenses will frequently cure the trouble. Any cross eye can be cured, if, when you cover the straight eye with your hand the crossed eye becomes straight.

We are always pleased to assist any of our subscribers to any information they desire, and hope they will communicate with us on any difficult case they meet. With the practical hints we have given on the detection of cataract, we should like some letters of enquiry regarding customers who are blind in one or both eyes from this disease.

We would be pleased to receive any enquiries regarding double vision or "casts in the eye," in any and all directions. Diseases of the eyelids is also a subject about which the optician should know more. We will soon commence a course of articles on all diseases of the eye the optician is likely to meet with.

Turning in Pinions.

[BY VINCENT LAUER, IN *Allg. Journ. d. Uhrm.*]

A.—Center Pinion.

A FITTING pinion having been chosen and tested in the depthing tool, whether a good depthing may be produced therewith, the first thing to be done is to broach the hole sufficiently so that the center staff fits in tight.

The pinion is mounted upon a round, well-fitting turning arbor, and the shoulder for the wheel turned first; the leaves are turned down until removed. Should the hole of the center wheel be too small, it is broached as much as necessary. The wheel is placed on so that it fits scant, and has to be driven home by hammering.

The upper pivot is turned on next; its shoulder is permitted to project only little beyond the points of the riveting; the pivot is finally polished well, and the edge of the shoulder chamfered somewhat. The wheel is now riveted; it is first driven tight in place with a bone or wood punch, until it rests firmly upon the shoulder of the pinion leaves, and runs true and flat; the protruding points are next riveted with a polished flat hole punch, taking care not to place the latter upon the pivot shoulder, whereby this might be damaged.

There are at present small machines for riveting the wheels; they are practical in so far that the punch stands always vertical to the pinion. Beside this, a small steel riveting tool, which is well level and smooth, is placed under as support; the hole to be used must be only large enough to simply accommodate the arbor.

The space from the inside of the plate to that of the bridge is taken next with a height gauge, and the lower pivot turned accord-

ingly. If the pinion leaves are too long, they are turned shorter, but only enough, however, to obtain a shoulder, and to insure the free motion of the pinion.

It is a frequent occurrence that the leaves of the center pinion break by the bursting of the mainspring, because they were too short, and in consequence unable to offer sufficient resistance. A fine underturning is made at the lower pinion face, and the lower pivot is provided with a shoulder and finished like the upper one.

It only remains now to shorten the pivots; a sufficient quantity is turned off first from the upper one that it protrudes a little beyond the bridge hole; the center staff is next fitted in well, and the lower pivot shortened, whereby the canon pinion is mounted, and left at such a height that the hour wheel passes over the minute wheel as well as over the barrel.

The opening of the pinion with the ordinary five-cornered broaches is very time consuming especially if the former is well hardened. I use for this purpose the kind of broaches used by instrument makers; they render excellent services, the hole becomes round, and is quickly broached. Beside this, the repairer has it in his power to shape these broaches corresponding to the form of the staff, while the other ones have to be used as they are.

Fig 1 represents such a broach; it is easily made. A piece of round steel is filed in the shape of the center staff. So as to produce a smooth surface, it is ground with an oil stone or grinding file and oil-stone powder, moving it lengthways to the broach, in order to remove the scratches. After having prepared the piece of such a shape as pictured in *a*, it is filed off to one-half, and the scratches are also ground off from the face. The broach is then hardened in oil, and the face ground another time, after which it is ready for use. The rounding must not be ground at the second time, otherwise, its sharp corners would be injured, unfitting it thereby for cutting.

The pivots of the center pinion are polished best in a depthing tool, kept specially for this purpose; if none is on hand a small

composition file may be used: but the repairer must pay strict attention, otherwise the pivots become too conical.

The pivots of the center pinion are best polished in the depthing tool in the following manner: A soft iron disk, which at its circumference is turned flat and at right angles, and sits upon a turning arbor with pulley, is fastened between two points of the tool; the former is propelled by means of the latter. The center pinion is placed between the two other points, and is also mounted upon a turning arbor.

The two points between which the disc is mounted, are fastened with the screws, while the other two remain free, and embraced by a clamp, so as to enable the operator to slightly move the pinion to and fro during polishing, thus insuring a uniform polish. Such a clamp is represented in fig. 2; one of its arms is movable by means of a screw for obvious reasons. Rod *a* is of round steel, part *b* is

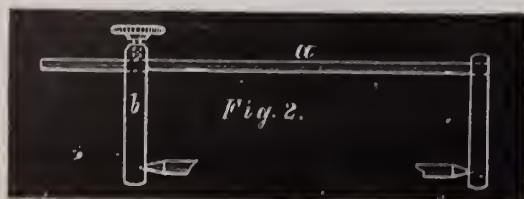

placed a little closer than the points of the depthing tool. A drill bow is now fastened upon each pulley, and both parts, pinion and disc, are set in motion with them. Having provided the polishing disc with red, the depthing tool is placed thus that disc and pivots touch each other. The red must frequently be renewed, since the disc soon becomes dry.

Both bows are driven with one hand, while the pinion is moved a little to and fro, by means of above clamp. A clean polish is easily produced by help of fine steel red and iron disc; if not, use a composition disc finally.

The faces may also be polished in the depthing tool; a disc with beveled circumference is used for this purpose; the red is applied on the side turned to the face, as is shown in figure 4. Beside this,

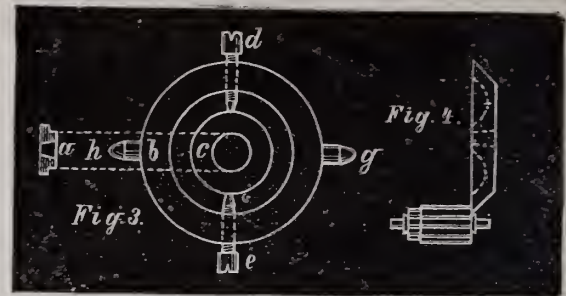

fig. 3 shows a small contrivance very highly to be recommended for polishing the rivetings. Ring *b* has at its circumference two rounded steel pieces *g* and *h*, which are held between two fingers, so that ring *b* can easily be turned. Within this ring, a second one *c*, held by two screws *d* and *e*, which may be turned in the other direction, is held in the same manner. A small iron or steel disc, the section of which is shown at *a*, is inserted into the opening of ring *c*. Its hole is countersunk, to prevent the polished pinion arbor from being injured.

If the small disc *a* is of steel, of course, it must be soft. The hole must be large enough that the arbor of the pinion can move a little to and fro. The front side of the disc is filed nicely flat, provided with red, and the pinion arbor, which is furnished with a pulley upon the other side, is inserted. One of the pinion pivots, here the turning arbor, is placed into a female center of the turning-tool center, the little instrument is held between two fingers, and the pinion is set into motion with a bow.

It is necessary, in order to be sure that the face becomes flat and sharp, that the small disc *a* is repeatedly flattened as soon as it shows hollows. The height of the polish depends upon the material used, but more especially from the skill of the repairer. The finish polishing may also in this instance be imparted with a small composition disc.

B.—Third Pinion.

The approximate height of a pinion with arbor is at once ascertained; if too long, the arbor is shortened, since it makes turning only difficult. The pinion is revolved in the truing tool, and the centers are turned on. The shoulder of the wheel is turned next, whereby the same care as by turning in the center pinion is necessary.

The arbor is turned round, ground and polished, and the riveting turned under, after which the wheel may be riveted in place. To determine the height of the latter, a height gauge is placed in the recess of the plate and opened until it is of the height to be occupied by the wheel; having found this, the distance from the upper wheel face to the shoulder of the lower pivot is measured, and the latter turned on and polished.

The bridge is next mounted in place, and measured from its inner side down to the plate, which measure then indicates the length of the pinion without pivot.

This distance ascertained, the upper pivot is turned on and finished. Should the pinion leaves be too long, the superfluity is turned away, until a short shoulder is formed, which is provided with a fine underturning.

The pivots are to be turned straight and with a flat shoulder, rather feeble at the same time, so that they need simply be finished with a pivot polishing file. When polishing, the pivot must rest in a suitable bearing, to get it as cylindric as possible. The polishing file is kept at right angles to the pinion, to obtain a flat shoulder. The pinion is next placed in and tried whether it has the necessary

shake for a free motion; in case it should still be too long, one of the shoulders is still turned back, taking care not to weaken the pivot. The edges of the shoulders are slightly chamfered, the pivots shortened, if it should be necessary, rounded, and the face finally polished.

C.—Fourth Pinion.

Having made the same preparatory work with this pinion, as specified in the preceding, the shoulder for the wheel is finished, the wheel mounted and riveted in place. The first work then is to turn the pinion at a correct length, so that the third wheel may seize in firmly, and, on the other hand, that the balance or its banking pin cannot come in contact with the pinion leaves. The arbor is turned next and polished, and a small underturning introduced at the face. Great care is necessary when turning the fourth pivot, on account of its length. The pivot shoulder comes in close proximity to the wheel, since the latter is located close to the plate. The long pivot is burnished upon a fourth wheel bearing of the burnishing tool; if this is not on hand, it may be done with a small composition file and red.

The height of the space between the plate and bridge is measured next, and the upper pivot is turned on in conformity and finished. The subsequent working of the pinion can be gathered from the preceding remarks.

D.—Scape Pinion.

The most important pivot connected with this pinion is to place the wheel at the correct height to the cylinder. The old pinion is generally still on hand, to serve as gauge for the size proportions of the new. If the wheel has not stood at correct height, it can be easily guessed how much has to be added or deducted.

The pinion is shortened so as to facilitate the fine turning, and the two centers are turned exactly to the center of the pinion. The wheel is fitted upon, the riveting turned under, after which the pulley is shifted, the correct length given to the pinion leaves, and the lower pivot slightly turned on. After having measured the inner distance of both jewel holes, the upper pivot is turned according to this measure, and finished, after which the wheel is riveted. The lower pivot is finished next, as well as the remaining work on the pinion.

In case the old pinion cannot be used for measuring, Saunier specifies the following method: Turn a small disc, which can be laid into the sink. The scape wheel is laid upon this disc, the cylinder mounted and examined whether the wheel seizes at the correct place in the cylinder; if this is not the case, a thicker disc is employed, or otherwise, turned feebler, until the wheel lies in its appropriate place.

The measure is now taken with a gauge over this disc, and to embrace the outside of the lower jewel hole; the thickness of the latter is next measured by itself and deducted from the whole, the remainder gives the distance from the lower pivot shoulder to the wheel shoulder. If the wheel has been fitted on, as stated, the sum found is added from the wheel shoulder from below up, and the pivot is turned accordingly. The remainder of the work for finishing the pinion is the same as described in the preceding.

The Setting of Watch Jewels.

[By VINCENT LAUER, in *Allg. Journ. d. Uhrm.*]

SINCE it happens frequently at present that one or more jewels must be replaced in watches, I am so bold as to give the method pursued by me for doing it.

Many different machines have been invented and constructed for this purpose, but they are very delicate, since they must be so, consequently very easily broken, and it is troublesome to put them in order again.

The setting of jewels by many watchmakers, is regarded as a job of great difficulty, chiefly for the reason, however, because they never tried seriously, or else they went to work in a very unpracti-

cal manner. A recess is often made with some kind of a contrivance, a jewel is singled out and rubbed in with a steel point. This method cannot be recommended, however, because, if the setting is made before having found the jewel, the repairer is not certain that he will find one that insures the correct shake of pinion and pivot; and, beside this, the rubbing of the setting by hand offers no security that the jewel will remain in the center of the setting, not to speak of the indifferent appearance of the work.

If there is a good setting in which to locate the jewel hole, lift up the rubbed-down bezel, pick out a jewel hole, and press down the bezel upon a lathe by either fastening or cementing the plate or the bridge.

Since the majority of watchmakers at present own a chuck lathe (or a Swiss lathe with a Glashütte chuck arrangement), upon which settings may much more expeditiously be made by free hand than upon the unwieldy universal tool, I shall describe the setting of jewels according to the former method.

Common gravers may be used for turning the settings; they are to be ground right tapering, with pivots provided with small faces,

as is indicated in accompanying figure. The small faces of *b* and *c* are ground in different directions, and a graver is used suitable to the purpose, whether the shoulder of the setting is to be turned flat or hollow. The pressing down of the jewel bezel is done with a steel point *a*, which is somewhat rounded off and well polished; it is mounted upon the rest of the lathe, and the setting rubbed down

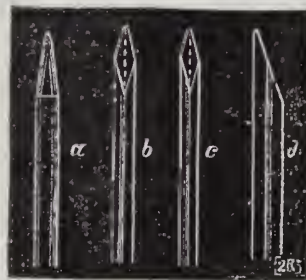

FIG. 3.

with a firm pressure, whereby the steel point is moistened with water or oil.

But if a jewel hole is to be replaced, the setting of which is bad, it is broached sufficiently until the cut around it has been taken off. If the wheel or balance has previously stood straight, and there is no danger that the present hole in the bridge or plate has been moved to one side, a bushing is turned in and soldered. Although soldering is not in great favor with many watchmakers, still it is at times opportune, in repairs. The tin must be used very sparingly, however, so that it does not flow upon the gilt parts. The bushing, as well as the hole to be bushed, are moistened with soldering fluid, the former is inserted, the joint laid around with tin pallets, and melted above the flame.

If the bridge or the corresponding place of the plate are thick enough, and will bear it, the bushing may also be riveted in place; the jewel may also be mounted in a bushing and then driven in, as will be elucidated farther on. If the wheel is to be placed straight first, a solid bushing is to be inserted, the uprighting is done by the other jewel hole, and the bushing drilled through.

In order to exactly retain the end shake of the pinion, drill first a fine hole through the bushing, and place in the pinion, and remove sufficient metal from the bushing, until the correct shake of the arbor has been established; the jewel is now laid sufficiently deep until even with this plane. If this cannot be seen well, on account of the recess, place the jewel into the setting, lay a small, smooth piece of metal upon it, and it can be seen at once whether the jewel is to be sunk still deeper or not.

A jewel hole that fits well to the pivot and is of an appropriate size, is to be picked out. The plate, or the bridge, is now cemented, and truly centered according to the hole in the bushing, to be done with a sharpened pegwood. The recess for the jewel is now turned in; this must be diligently tried, until it fits easily, but without shake. The jewel is for this slipped upon a piece of sharpened wood. When the jewel enters, the shoulder is turned off down to a small remnant, leaving only so much as is necessary to insure its firm position. A rather deep cut is now turned near the recess, outside, to produce the folding-over bezel. The jewel is moistened with oil or water, so

that it remains in the countersink; it is now placed within, and the bezel rubbed down with steel point *a*, as stated above.

The piece is then cemented on the other side, and the jewel bared, by turning out either bevel or hollow the edge of the setting, and polishing next with hard wood and red.

If the stone is to be mounted in a setting, and then to be driven in, it is advisable to use a perforated chuck of the spindle for this purpose, as represented in the accompanying cut. A hole is drilled



FIG. 4.

into the fastened piece of brass wire *a*, the stone set, and this piece turned in such a manner that it enters partly into the hole of the plate or bridge. The bushing is now turned down and carefully driven into the opening, until the jewel stands at the correct height, so that the pinion has the necessary shake.

The bushing is now turned out from the other side, as explained above. Brass punchings may also be used in place of the wire, and they are to be cemented upon a cement chuck; they are to be dressed round by the hole, and the outside of the bushing is turned correspondingly.

The jewel bushings provided with screw thread, are prepared in the same manner. The cement chucks must be placed very exact into the spindle, so that the setting can be inspected when preparing it. Gilt parts are taken off from the cement chuck while hot; if they were torn off in a cold condition the gilding would suffer; the adhering cement is dissolved in pure alcohol.

Whoever desires to learn this method of jewel setting will be able to execute a substantial and handsome setting in a short time.

Replacing a Broken Balance Staff.

TO REPLACE a broken Swiss balance staff, the repairer may make one by driving a piece of steel into a brass collet, then harden by heating it to a cherry red, and plunging it in oil or water; it must next be tempered by brightening a portion with Arkansas stone or otherwise, by holding it near a flame and letting down to a full blue; in this condition the center must be filed in the pin vise, the arbor turned true, and the brass collet turned to an approximate size. All parts of the arbor and collet must be forwarded in equal proportion, or it will come to grief if one pivot is turned nearly the right size before the other one, and back hollow has been turned sufficiently small. The pinion gauge should be freely used on the broken staff, and if both pivots are broken but the staff is good in other respects, it will be a good pattern for the new, and show where the shoulder must be for each pivot. The gauge applied outside of bridge and foot jewels in the plate, with end jewels removed, will give the length of arbor and pivots, sufficient being allowed for end shake. The arbor should be turned as short as convenient, as long arbors are apt to become bent in polishing, beside giving unnecessary trouble in turning. When turned small enough, the roller must be carefully fitted in with cutting crocus in the process of polishing, and the arbor must be only slightly tapered; it must be driven on the right distance, when filed, with a hollow brass punch, the last thing, when trying the escapement; if too tight, they will be difficult to get on or off, and if at all loose, will not hold. Taking them off is not contemplated in the ordinary routine, and the riveting claws and a punch over the pivot must be used to remove them. A very convenient stake is made by using a piece of metal with a hole large enough for the roller to go through; a slot is cut from this hole some distance to allow the arbor to pass along it, and the roller is thus supported all over at the back, and allows of force being used to remove it. This tool is very useful, also, for putting on the hair-

spring collet, as the roller can be passed underneath, allowing the seat for the balance to rest on the outer face, and saves injuring the roller, which must occur if the latter itself is in contact with a stake.

Having finished the arbor and roughly formed the part for the bottom pivot, and what is called a safe, that is, turning the arbor nearly through below the pivot, so that in case of a slip or catch it may break there, we finish the collet and fit the balance and hair-spring collet. The height from bottom of brass collet to top pivot must be carefully noted by gauging or careful comparison of the old and new piece, as the eye is apt to be deceived; and leaving the rivet rather high and the collet a little too long, the inexperienced will be surprised to find that the pivot and shoulder which appeared all right, is just a pivot and shoulder too high, and the pleasure of turning or breaking a new pivot and shoulder out of the rough brass and steel will show the error he has made. The excellent practice of undercutting rivets and shoulders makes them appear as long again as they are, and a good graver and skill in using it are the sure roads to success; at this job, the pivots being turned nearly right size and shape with a sharp pointed graver. Then a cutting burnisher made from a piece of polished steel, hardened when made, with a rounded edge to form the conical shoulder; this, when sharpened on rough emery sticks to cut, and fine emery to burnish, will do all that is required for a perfect job in the ordinary turns. If not capable of turning anything finer than an arbor, the Jacot tool and pivot files may be used, and a notch being cut where the pivots are to be, by shifting the arbor from the large to the small nicks in the tool as it is reduced, a pivot may be worried out of the arbor with the pivot file, which will only be good enough for the commonest work. The pivots should be left full long, and rounded the last thing after the balance is riveted, so that a chance is given for improving the freedom of the balance by making the end shake and height right by shortening top or bottom pivot as may be most desirable. The riveting should be done by a half-round punch, with a back whetted to nearly a sharp edge. This will go into the rivet and drive it down as well as out. A blow at four different parts of the rivet should tighten it flat and true, and then the hammer applied lightly to the punch, while the balance is continually moved with the finger, would finish it. If not flat, the rivet must be hammered at the part where the balance projects. If this latter has three arms, it may need flattening, by striking them with a light hammer, or the pliers may be used with advantage; resting the point of the pliers near the center of the balance on the arm, and using the edge of the balance as a fulcrum; or the balance may be held in the fingers and pressed against the edge of the work-bench to flatten it. A combination of these plans is sometimes necessary.

Escapement makers usually rub and burnish their balances on the staff before turning the pivots, by holding a pointed center against the rivet while revolving in the turns; but repairers will not find this as convenient or safe as the other plan of riveting, which must be adopted in the replacing of cylinders, and they will not get enough of practice at both to be very reliable in either. Most of the directions given for the balance staff are applicable to the pallet staff, though it differs from it, being secured to the lever and pallet by screwing. Working usually in through jewel holes will require a square-edged polisher and burnisher to finish the pivots. The arbor has usually a very thick bottom arbor or shoulder, which is held in the pliers when it is desired to unscrew the pallets and lever. In making a new staff, a piece of steel wire may be turned while it is soft, and the screw made on it by using the lever itself as the screw plate; when a good thread has been cut on the arbor, it should be hardened and tempered, and the height from the shoulder, on which the pallet rests, carefully gauged, and the bottom pivot made and finished. The action of the wheel on the pallets should now be observed by screwing lever and pallets together and putting them in, and holding the arbor as upright as possible; or putting the escape cock lightly on in contact with the upper arbor. If the position appears right, the height should be gauged from the old arbor, or by filing a piece of brass wire until it fits between upper and lower holes,

and gauging that for the height. When the pivot is finished, the escapement should be tried first without the balance. On moving the lever and pallets, the tooth should have an equal amount of drop on to each pallet; this will prove the correct sizing and depth of the wheel and pallets, and an equal amount of run up the pallet, after the tooth drops, before the lever comes against the banking, which limits its motion. If there is much run on one pallet, the other one may not have the tooth at all, or only just as the lever comes to the rest; this shows it to be out of angle, and if the steady pins are tight in pallet and lever, the hole must be opened, or the pin filed or bent to allow it to be shifted on the lever, so that the pallet may leave the tooth before the lever has traveled the full distance. If both pallets refuse to leave the teeth, it would show the banking not to be wide enough; but if the watch has ever gone, the fact proves the banking wide enough; and inability to leave one pallet is the same effect as inability to leave both, and all alterations which make one pallet deep, make the other one shallow in the same proportion. Common levers have considerable drop, and run up the pallet as well as variable draw or retentive action of the wheel on the pallet. Fine watches allow of these actions being very close, if the wheel drops at equal distance of the lever's motion, and allows a little more motion of the lever before it comes to the banking; and then the ruby pin leaves freely, and the guard action has a little shake between the banking and roller edge, without danger of sticking in the roller, or allowing the wheel teeth to get off the locking face on to the impulse plane, until pulled off by the action of the ruby pin, the escapement being free may be considered perfect.

Hair Springing.

IT IS A common thing for watch wearers, when they find their watches a little erratic in their action, or given to stopping, to administer a little poking at the scape wheel, if a Swiss watch, with the frequent result of damaging the hair spring in so doing. Two watches came into my hands this week, in one of which the scape wheel was broken, while the hair spring of the other one was in a complete tangle, solely due to officious poking about on the part of the wearer. When a spring has got very much out of flat, by some cause, the best way to correct it is to take it down entirely from the stud and collet, and lay it upon a piece of glass, or, preferably, the plate-glass of a watch, under which is placed a piece of white paper. One could be mounted up permanently in the turned lid of a wooden box. The advantage of thus raising the spring a slight distance above the board paper will be apparent to all upon trial. If the spring is laid upon the bare paper the shadows cast by the coils become mixed up with the coils themselves, and confuse the eye by their indistinctness. If a piece of glass intervenes the shadows pass below and away, and each coil can be distinctly seen and managed with ease. In correcting a damaged spring a fine pair of tweezers and a firm and small tool, such as a broken pivot broach or a blunt needle, are needed. By carefully bending up or down, from side to side, according to necessity, the spring may ultimately be got right. It is always a trial of patience, and by many considered a waste of time for a workman to attempt to correct a damaged spring, if much out of flat; they much prefer to remove the old and substitute a new one. With most country jobbers this plan is not always expedient, as no very large stock of springs is kept by them, and the time lost in adapting an unsuitable spring to a watch, or the sending for a new one, entails so much time lost, and lessens the pecuniary return so much, that every effort is made by them to correct the existing spring. The probability, too, of getting the watch to go at once to its old rate and correctness of time-keeping, is an inducement to many to adopt the plan of recoiling. If springs of the same strength are at hand, then, by all means, fit in a new one, and such is certainly the most

commendable plan, all things considered. It sometimes happens that a careless workman, in removing a balance wheel and spring from its position, does not sufficiently clear the latter of the pins or the pinning-up stud hole, and, in consequence, the spring gets drawn into a spiral or cone shape. The best way to correct this is to place the collet with spring in on a pivot broach or similarly shaped tool, and with the tweezers take hold of the outer end of spring and pull it the reverse way to that it has gone, and as nearly as possible the same distance it was accidentally pulled in taking it from the watch. This, while slightly increasing the diameter of the spring, will invariably restore it to its former flat position, or an approximate one, which can subsequently be treated as in the case of a simple bend. The coils should then be carefully closed up to the old position. When the diameter of the spring is greater than is correct according to the position of the stud and pins, it should be closed up carefully for two or three coils, taking care that they are kept equidistant. If the diameter of a spring much exceeds the arc described by the regulator pins, the coils will not work regularly. When in position they will at one part be close together and at another wide apart. A spring, therefore, should unfaillingly be of a correct size. The stud hole should be upon the same line, if a circle was made, passing through the pins or curb, and having the pivot hole for its center. Neglect of this most important item is a prominent feature in common Swiss watches, and it occasions much trouble to workmen in getting a correct action of the spring.

In such cases, when the regulator is moved to "fast" or "slow," the hair spring is forced out of its correct position, altering the beat of the watch, or causing the spring to become entangled with the stud or center wheel. It should always be observed that, excepting at the extremities, where pinned, and at the regulating pins, the spring should be free of contact in every way. In lever watches the spring is often left resting on the regulator bar, between the pins, and this, while retarding its free action, also causes a scraping noise, perfectly audible to the ear, even at some distance. Beside this, should the watch be altered for timing, the spring may either be lifted up against the bars of the balance or lowered on to the plate. The writer of this has frequently had customers come to him, because they found their watches gained more when the regulator had been moved to make it go slower; this falling of the spring upon the plate, or the raising of it to the bars, and the consequent friction, being the true cause. It is a common failing, wherefore attention is called to it. Amongst watch wearers much doubt seems to exist as to the correct signification of the words "fast" and "slow," or their initial letters, or the French words "avance" and "retard." It is in this respect that the doubt arises. Some people think that if a watch is losing the regulator point should be moved to the "slow," or, if gaining, to the "fast;" this is incorrect. If a watch is losing time, you, of course, wish to make it go faster, and, therefore, need to push the regulator to "fast," and *vice versa*. I write this for the benefit of those who may have a little doubt or uncertainty in their minds upon the matter. No correct rule can be given as to how far a regulator should be moved to produce a definite variation in the time-keeping. Some hair springs are so highly sensitive and susceptible to the slightest touch, while others are not easily influenced.

In moving a regulator or altering a spring it should be borne in mind that each individual beat is thereby altered, and when it is considered that watches ordinarily make from fifteen to eighteen thousand beats per hour, an idea can be formed of the slight variation some watches need to correct their errors. It is frequently found that a collet is so loose upon the balance that the least touch will move it from its place, or else it gets shifted while in wear. The best way to close the collet up to make it fit tight is to place it loosely on a small round file or broach, and, while held there, pinch it up with a pair of pliers. If this job is attempted without the collet being placed upon something of this kind it may get broken in halves by the nip of the pliers.

(To be Continued.)

Workshop Notes.

CLEANING GILT SURFACES.—Gilt metallic surfaces are best cleaned with a solution of 30 grains borax in 1 kilogram water; rub them gently with it, rinse with cold water, and dry with a soft linen cloth. Picture frames only bear pure water.

TO PROTECT THE POLISH OF METALS.—Melt one part by weight of best wax paraffine, and when sufficiently cooled, add three parts of petroleum. Mix well together, and apply to the polished article by means of a soft brush. The protecting film need only be very thin, wherefore not too much should be applied.

SOLDERING GERMAN SILVER.—Dissolve granulated zinc in spirits of salts in an earthen vessel. Cleanse the parts to be soldered, and apply the spirits of salts. Next put a piece of pewter solder on the joint, and apply the blowpipe to it. Melt German silver one part, and zinc, in sheets, four parts, then powder it for solder.

TO SOFTEN A SPRING.—A spring may be laid flat and its temper drawn between two plates fastened together by a screw through the center, and placed upon the annealing plate. A small piece of whitened steel is laid upon it, to enable the operator to judge of the degree of heat. Before opening, let it cool. When drawing the temper lay the coils farther apart.

OPAQUE BLUE ENAMEL.—Five parts pulverized crystal glass; 1 part calcined sheep bones; $1\frac{1}{4}$ parts calcined borax; 1 part cobalt oxide; $\frac{1}{4}$ part tin oxide. Pulverize all components. First put in the glass, then the borax; when melted, add tin oxide, then bones, lastly cobalt oxide. Melt it three times and give it a strong heat. Never pour in water—it loses its opacity.

TEMPERING VERY HARD STEEL.—The following is said to be a good method for tempering very hard steel: One part wheat flour and two parts salt are mixed and dissolved with four parts water. The steel is heated and covered with a layer of this mixture, in which it is immersed. It is then heated to a cherry red and placed in cold water. If the operation has been done carefully, the steel will have a nice white surface.

OXIDIZING SILVERWARE.—Silver may be oxidized by the following process: Sal ammoniac, 2 parts; sulphate of copper, 2 parts; saltpeter, 1 part. Reduce these ingredients to a fine powder, and dissolve it in a little acetic acid. If the article is to be entirely oxidized, it may be dipped for a short time in the boiling mixture; if only in parts, it may be applied with a camel-hair pencil, the article and the mixture both being warmed before using.

MIXING POLISHING MATERIAL.—Crocus should be thoroughly beaten up on glass or a polished steel stake to a stiff paste with very little oil. Far too much oil is often used, and the mixture left thinner than it should be. Olive oil is not suitable, and if used, the polishing stuff becomes sticky in a day or two. Refined sperm oil answers well. Diamantine should be mixed in the same way, as dry as possible, so that when it is used the polisher is only just damped with it.

MERCURIAL COMPENSATION.—In the mercurial pendulum the jar of mercury does not answer so quickly to change of temperature as the steel rod, and preference is therefore now generally given to the zinc and steel arrangements; still, the elegant appearance of the mercurial renders it suitable for show regulators, for which it is often used. The following are the dimensions of a good pendulum of this class: Steel rod, 0.3 inch diameter, 34 inches long from top of free part of suspension spring to bottom of sole of stirrup, side rods of stirrup 0.3 inch wide and 0.125 inch thick; height of stirrup inside, 8 inches; bottom of stirrup 0.5 inch thick with a recess turned out to receive the jar; glass jar 7.6 inches deep and 2 inches diameter inside; outside 2.25 inches diameter and 7.8 inches high; height of mercury in the jar about 4.7 inches; the weight of the mercury was 11 pounds 12 ounces.

TO REMOVE NAME FROM DIAL.—Take a little diamond powder made into a paste with fine oil, on the end of a copper polisher, the surface of which has been freshly filed and slightly rounded. On rubbing the marks, they will be seen to rapidly disappear. The surface is left a little dull; it may be rendered bright by rubbing with the same powder mixed with a greater quantity of oil, and applied with a stick of pegwood. Operators will do well to previously experiment with several degrees of fineness of the powder on old dials.

SPRING COIL KEY.—A key for turning the spring coil upon the balance is made as follows: A steel arbor, provided with a handle of suitable length, ends in a cone at its end, into which a hole is driven and provided with a wing, filed sharp below. The balance is placed upon the little table above spoken of. Place with the right hand the little instrument upon it in such a manner that the balance pivot enters the hole, and a little knife is inserted into the cut of the collet, which thus may easily be moved until the stud occupies its hole exactly.

HARDENING GOLD SPRINGS.—Gold detent, thermometer, suspension, and balance springs, can be imparted a high degree of elasticity. Rolling hardens them, but they are rendered very brittle thereby. They can be made supple and elastic, not by hardening, as in the case of steel, but by annealing, care being taken not to exceed a certain degree of heat. The spring may be coiled on a block, and placed in a tube with a smooth steel lid, then heat the tube in the flame of a spirit lamp, and, as soon as the steel is of a blue temper, remove the flame and allow the whole to cool.

PHOSPHORESCENT POWDER.—Phosphorescent powders can be prepared as follows: 10 ounces carbonate and phosphate of lime, obtained by calcining oyster shells and sepia bones, are mixed with 10 ounces caustic lime; $2\frac{1}{2}$ ounces of chloride of sodium (common salt), calcined, are then added, and 20 to 25 per cent. of the weight of sulphur, 3 to 7 per cent. sulphide of calcium, barium, strontium, magnesium, which has previously been exposed to sunlight. To improve the lighting power, Messrs. Tik & Corty add a phosphorescent substance, which they obtain from the ashes of marine plants. These powders, when mixed with varnishes, render the surfaces which they cover luminous. Collodion, paraffine, soluble glass, etc., can be incorporated with them.

TO WIDEN A JEWEL HOLE.—Chuck the hole in the lathe with cement. Place a spirit lamp underneath to prevent the cement hardening. Hold a pointed bit against the hole while the lathe is running until the hole is true, when remove the lamp. The broach to widen the hole should be made of copper, of the size and shape required, and the point, after being oiled, should be rolled in diamond dust until it is entirely covered. The diamond dust should then be beaten in with a burnisher, using very light blows, so as not to bruise the broach. After the hole is widened as desired, it requires polishing with a broach made of ivory, and used with oil and the finest diamond dust, loose (not driven into the broach). Watch jewelers polish the holes with a copper broach, using very fine diamond dust and a high rate of speed.

FOCAL DISTANCE OF SPECTACLE GLASSES.—Place the end of a measure of 30 or 40 inches in length against a smooth wall, or other suitable ground, in plain view of some well-defined object a few rods distant, as, for instance, a building or window on the opposite side of the street. Then place the edge of your lens on the measure; and move it backward or forward until a spectrum is formed, or, in other words, until a clear and distinct outline of the distant object is produced on the ground against which your measure rests. This point will represent sufficiently near for all practical purposes, the exact focal distance of the lens, and will correspond in inches with the number on all properly marked convex spectacles. For mending fine steel spectacle frames, use the best gold solder, in preference to silver or brass solder.

Trade Gossip.

Toy pistols are a new design in lace pins.

Business is not booming, but what there is of it is very good.

Otto Hausberg, of Buerk & Hausberg, will sail for Europe July 30.

A. J. Grimberg, of Grimberg, Goodman & Pollock, will return from Europe on the 15th inst.

M. Falkenau, of Falkenau, Oppenheimer & Co., is in Europe selecting goods for the coming season.

The Board of Trade and Transportation has denounced the taxes levied upon commercial travelers by some of the states.

Leroy C. Fairchild & Co., is the name of a new firm just formed for the manufacture of gold pens, pencils, pencil cases, etc.

F. P. Locklin has admitted to partnership P. H. Locklin, his brother, and the firm will hereafter be known as F. P. Locklin & Bro.

Montgomery & Co. carry a full line of jewelers' tools of all descriptions, and keep everything that is new or novel in goods of this kind.

W. W. Hayden, with Leroy W. Fairchild, and Miss Marie Kinney were married June 23d at the residence of the bride's parents, Indianapolis, Ind.

Isaac S. Lawrence, wholesale dealer in jewelry at No. 3 Maiden Lane, made an assignment June 18 to Charles S. Benham, giving a preference for \$2,500.

H. F. Barrows & Co. have secured a patent for an improved roller chain, which has a perfect edge and is flexible, making a desirable article for bracelets and neck chains.

W. E. White & Co. will introduce many new designs in their line of plated bracelets this season. They have also a combination lace pin and glove buttoner among their novelties for the fall.

A telegram from Hamilton, Canada, says: The customs officials have confiscated considerable jewelry which an American firm tried to smuggle into Canada. The matter is kept very quiet, as more seizures are expected.

John Frick is preparing the authorized League badge in the form of a watch charm, which will be acceptable to those members who have an objection to decorating themselves with the badges of the various societies to which they belong.

The Willem Watch Case Co. have removed their New York office from No. 1 1/2 to Nos. 14 and 16 Maiden Lane, which is fitted up in a very tasteful manner, and will be occupied jointly by H. Muhr's Sons and the Willem Watch Case Co.

C. I. Richards Brown & Co., have just introduced a new form of bracelet catch, which is patented by them. The catch holds the bracelet closed past the possibility of unclasping. The illustrations in their advertisement show the manner of its construction.

The wholesale jewelers of Chicago, to the number of about fifty, gave their employees a day off at South Park picnic grounds on Saturday, the 16th of June. The management was under the supervision of Messrs. S. H. Hale, Otto Young, and A. L. Sercomb.

A gentleman who has heretofore been prominently identified with the National Guild, informs us that at the May meeting in Chicago but three states were represented, and that there was not a quorum present. He says the Guild is dead, likewise the state associations.

The new patent setting for jet and onyx goods introduced by Fowler Bros., has already become very popular in the trade. The setting is so constructed as to enclose the stone securely without having any of the metal visible. It adds greatly to the attractiveness of this class of goods.

Joseph Steinau, of Cincinnati, who has acquired considerable notoriety in the trade, is again a candidate for a compromise with his creditors. His previous failure was criticized severely by some of those to whom he was indebted, notwithstanding which fact some of the same names are found in the list of those who have aided and abetted him in this last calamity. Mr. Steinau is now in the "sere and yellow leaf," and announces that this is his last effort, for which the trade should be duly thankful.

Although three or four crystals of the genuine precious topaz, remarkable for size and clearness, have been found near Pike's Peak, Mr. R. T. Cross asserts that the stone which is cut in Colorado and sold as topaz to tourists is not topaz at all, but simply smoky quartz, or the cairngorm stone of Scotland.

The Illinois legislature has enacted a law providing that in sleeping cars where the lower berth is occupied and the upper one not taken, the upper berth shall be thrown back so that the occupant of the lower one can have more room and ventilation. This is a good idea and should be adopted in every state.

Charles William Schuman has published for private circulation a letter story in verse, written by himself, entitled "The Emigrant of 1845." It contains some original and beautiful sentiments, and will be treasured by his many friends as a cherished souvenir of one so well-known in the trade as the author is.

W. A. Smith, of Columbia, Tenn., has admitted to partnership J. S. Guthrie, late of Eminence, Ky. The style of the new firm will be Smith & Guthrie. The business will be continued at the old stand. The store has been fitted throughout with new fixtures, making it one of the handsomest jewelry stores in the south.

Haug & Luthy is the name of a new firm recently established in this city for the purpose of conducting a manufacturing jewelry business. They will devote their attention exclusively to fine diamond mountings, settings, etc. Mr. Luthy has for several years been Superintendent for Messrs. Baldwin, Sexton & Peterson, and Mr. Haug is well known as a manufacturer of setting galleries, etc.

A club is being formed in a New Jersey town for the purchase of sixty-five gold watches. The club must number sixty-five persons, who pay \$1 a week, and every Tuesday one of the members draws a gold watch. Those who draw a watch must give security that they will continue to pay their \$1 a week for sixty-five weeks. Twenty-five persons have already signed the paper agreeing to the conditions.

Messrs. Pearce & Hoagland, manufacturers of gold pens, pen holders, toothpicks, etc., of Providence, R. I., are adding many new and attractive styles for the fall season. One of the greatest novelties is a quill pick, so cut and arranged that it is held in a holder made either of pearl, ivory, celluloid, gold, plated, or nickel, and the pick can be replaced by a new one at any time from the reserve in the other end of the holder.

A retail dealer who does not want his name given writes us as follows: "After reading your leading article in May issue, I was not slow in following the timely advice given, and added musical instruments to my stock. I have received second shipment since. I am carefully watching your able pen, and in the fall may add books, engravings, etc., a big display of paintings, etc., in the winter season. You cannot estimate the good you are doing the trade."

The Chicago Watch Case Company call attention to their new line of 18 size stem winding gold filled cases, made under Coe's patent. The "Crescent," cases are interchangeable, being so constructed that they will fit all 18 size American movements. They have solid gold bows, joints, plugs, and thumb catches, and are guaranteed by special certificate. This company is presenting some neat and attractive designs in other filled goods that cannot fail to excite attention.

C. G. Alford, of this city, who is now sojourning in the Adirondacks, has forwarded to the members of the Executive Committee of the Jewelers' League a fine catch of trout. One of the beauties weighed six pounds. They arrived just in time to be served at the regular monthly meeting of the committee, and were hugely enjoyed by the members who can't get away to the woods. The base insinuation that these trout were caught with a silver doctor is repudiated by the committee with the just indignation so base a calumny warrants.

An English convict, who is just out of state prison, has recently been victimizing the trade to a considerable extent. His name is believed to be Samuel Lobley, but he assumes aliases to suit his convenience. He is described as being a man about 24 years old, 5 feet 7 inches high, light complexion, gray eyes and a smooth face, quite plausible and insinuating in his manner. His plan is to represent himself as a relative of some person well known in the trade, and, after buying a bill of goods, pays for them with forged checks. He adopts very ingenious methods, and has succeeded in deceiving some of our shrewdest business men. Having worked New York he is now making a tour of the prominent cities, and the trade is warned to be on the lookout for him.

J. M. Chandler & Co. have published an interesting circular explaining why Hagstoz & Thorpe cut them off from their list of jobbers. This practice of some manufacturers of cutting off respectable jobbers from their lists, and publishing the fact to the trade without explanation, thus reflecting upon the standing of the jobber, has been indulged in too frequently in late years, and jobbers do not propose to submit quietly to such treatment. The circular of Chandler & Co. is highly interesting reading, and would indicate that they intend to defend their rights and their reputation whenever attacked.

According to *Le Journal de Pharmacie et de Chimie*, M. Berthelot, the eminent French chemist, has been led to suspect that the true element carbon is unknown, and that diamond and graphite are substances of a different order. Elementary carbon ought to be gaseous at the ordinary temperature, and the various kinds of carbon which occur in nature are in reality diverse combinations of the true element carbon included under one general formula. Spectrum analysis is thought to confirm this view; and it is supposed the second spectrum seen in a Geissler tube belongs to gaseous carbon. This spectrum, which has been recognized along with that of hydrogen in the light of the tails of comets, indicates a carbide, probably acetylene.

Mayor Edson has instructed Marshal McDermott to examine into the manner of pawnbrokers in the past, and to require an affidavit to be presented by them of the number of sales had by each during the past two years, and in what papers such sales were advertised, before granting a license under the new act. The Marshal has reported to the Mayor that eighteen pawnbrokers have closed their places of business, and the inspectors have been instructed to see that they do not continue the business unlicensed. The total number of pawnbrokers who have complied with the requirements of the new law are seventy-five, making the fees received from this source alone during the past fortnight \$37,500, while about thirty pawnbrokers' applications, by reason of the insufficiency of the sureties, which are carefully examined by the Marshal, are still pending. Three loanbrokers have been compelled to take out a license under the act, the same as pawnbrokers.

The announcement is made in a recent number of *Galignani's Messenger* that Tiffany & Co., of this city, with a branch in Paris, have been appointed "imperial and royal jewelers and silversmiths" to Queen Victoria, the Prince and Princess of Wales, the Emperor and Empress of Russia, the Emperor of Austria, the King of Italy, the King of Belgium, the King of Greece, the King of Portugal, and other distinguished potentates. The artistic and refined taste displayed by Tiffany & Co. in the forms and decorations of their silver, have recently elicited commendations from representatives of the royal courts of Europe, and the Hon. W. H. Hunt, United States Minister to Russia, recently wrote a personal letter on this subject in which he said: "Compliments such as these from such distinguished rulers of the most enlightened countries of Europe are of more than ordinary significance. These are the tributes of approved connoisseurs in art to merit."

The skill in beating out and inlaying gold and other metals to which Homer so often alludes, is attested by the remains found in the tombs at Mycenæ, of which perhaps the most Homeric are the designs on the scabbards of swords, which, at the time when Dr. Schliemann's book appeared, were too much incrustated with rust to be made out, but which have been recently engraved and described by Mr. Koumanoudes. The subjects represented on these scabbards are a lion hunt, a lion attacking a herd of deer, winged monsters, fish, and plants. The manes of the lions are of red gold, their bodies of paler gold, probably electrum. So with the flowers—the stalk, leaves and branches are of gold, the calyxes of electrum. The same distinction of color is observed between the sea and the fish swimming in it, and also in representing the birds—in which the color of the blood flowing from their wounds is discriminated from the color of their feathers. Further variety is obtained by the use of enamel in portions of the background. In the description of the plowing on the shield of Achilles, the poet says that the furrow behind the plowman was black, as plowed land is, although being of gold. Probably to produce a change of color, a dark enamel, such as that found in the scabbards, was combined in the gold. Homer, therefore, so far from inventing the shield of Achilles out of his imagination, as was formerly contended, derived many details both of subject and technical execution from works of art which he had actually seen, and which inspired him with the conception of what a work by the god Hephestos himself might have been. So, again, in regard to the choice of subjects on these scabbards, and throughout the Mycenaean antiquities, they prove that when Hesiod describes the crown of Pandora as ornamented with "all manner of creatures such as the sea and the land breed," he borrowed these ornaments from the art of his own time.

Duhme & Co., of Cincinnati, caution the trade against a plausible young man who buys a bill of goods and presents in payment forged checks, the checks usually being for a larger sum than the bill amounts to; he taking the difference in cash. Occasionally he simply asks to have a check cashed, the names on the check being forgeries. The swindler obtained from Duhme & Co. a $2\frac{1}{8}$ karat diamond stud, a 2 karat diamond ring and a gold watch. The latter was an Edouard Ricard movement, No. 42,350, and the case an 18 karat gold, No. 15,078. A reward of \$100 is offered for the return of the goods, and \$200 for man and property.

The Dueber Watch Case Company has at last brought out, what they have long contemplated doing, a new style of case which they denominate a "plated" case, in contradistinction to the term "filled" case, as applied to cases nearly similar in construction. The Dueber Company announces that their new case is "plated," but guarantee that the center, pendants, bow and crown are solid gold, and that they contain more gold than is to be found in cases of the same grade of other manufacture. These goods are highly commended by dealers who have handled them, and, as they are sold at a reduced price, there is likely to be a demand for them.

The Emperor Charles V. carried a watch in 1530. It weighed twenty-seven pounds. In those days watches were scarce and costly, and, moreover, it was necessary that one who was destined to be honored by the possession of a watch should undergo a course of rigid training, and few could attain sufficient physical prowess to wear the then wonderful pieces of mechanism with noble and dignified bearing. A noble lord would occasionally drop in his tracks, and his royal timepiece would have to be wheeled home in a hand express. Another trouble with those old style watches was that they had to be wound up every ten or fifteen minutes, and a herculean task it was, too. The fortunate or unfortunate owner had to employ a corps of winders, for a healthy, old-time watch would wear out a half-dozen ordinary men a day, and many a slave wound up his career in his over-zealous service.

The New Haven Clock Company has just introduced to this market Harder's torsion pendulum clock, for which they are exclusive agents in this country. This pendulum is constructed on the rotary principle, and will run for four hundred days. Wherever they have been used they have met with approval, being correct time keepers, and involving no care or trouble to keep them running. It is claimed for them that they are less affected by atmospheric changes than the ordinary pendulum clock. These clocks are made in a variety of very handsome forms, and are attractive in appearance. The New Haven Clock Company has just occupied elegant new quarters at Nos. 16 and 18 Park Place, where they have abundance of room and plenty of light. Their offices are fitted up in the modern style of interior decoration, and good taste and refinement are indicated on every hand. There are but few such attractive offices and show rooms occupied by members of the trade either in this city or elsewhere.

Quite an important meeting of the Jewelers' Club was held recently to take into consideration matters pertaining to the annual celebration. The Club originally had for its main object the training of a base ball nine to compete with other clubs, and to provide for match games between such clubs; but these annual reunions have been so enjoyable, and have been so largely attended by members of the trade, that the idea of extending its usefulness has been forced upon the Club. Business men are so devoted to the drudgery of their daily work that they all get too little social relaxation, and whatever organization can entice them from their cares and anxieties for a brief period, is doing good work in the cause of humanity. It is proposed that the Jewelers' Club enlarge its sphere, and adopt new and more extended methods for the cultivation of social relations between members of the trade, to have, in fact, a Club where the members can meet and enjoy themselves rationally and sensibly among themselves. To this end a resolution was adopted inviting the trade generally to become members, and to aid in future in directing the policy and the fortunes of the Club. It already embraces in its membership many prominent and well-known jewelers, men of reputation and standing in society and in the trade, and it is desirable to enlarge the membership by admitting all in good standing in the trade, whether residents of this or other cities. The annual celebration of the Club will occur July 6 at Providence. The New York Club will leave the city by boat on the evening of the fifth, accompanied by a band of twenty-five pieces. A number of invited guests will be of the party, and it is believed that during the trip plans for extending the aims and objects of the Club will be matured. It has already contributed much towards the development of social intercourse and kindly feeling between members of the trade, and its possibilities in the future are without limit.



VOLUME XIV.

NEW YORK, AUGUST, 1883.

No. 7.

THE JEWELERS' CIRCULAR AND HOROLOGICAL REVIEW

*The recognized organ of the Trade, and the official representative of the
Jewelers' League.*

A Monthly Journal devoted to the interests of Watchmakers, Jewelers, Silver-
smiths, Electro-plate Manufacturers, and those engaged in the
kindred branches of art industry.

SUBSCRIPTION:

To All Parts of the United States and Canada,
\$2.00 Per Annum; Postage paid.

To Great Britain, France, Switzerland, Germany, the West Indies, Mexico, the
Republics of South America, and Australia, \$3.00 per annum. Postage paid.

All communications should be addressed to D. H. HOPKINSON, 42 Nassau
Street, New York. Advertising rates made known on application.

Retail Dealers and Outsiders.

To the Editor of the Jewelers' Circular:

I have read with much interest the articles in late issues of THE CIRCULAR relative to manufacturers selling their goods to outsiders at the same prices, or less, than they sell them to the legitimate trade. From personal experience I can testify that this is one of the greatest evils retail dealers have to contend against. We buy our goods from jobbers, or jobbing manufacturers, hoping to supply the demand in our vicinity on such terms as will allow us a fair margin of profit, only to find that dealers in other lines of goods have supplied themselves with precisely the same articles, and are offering them at lower prices than we can afford. They do this simply as an advertisement, hoping thereby to attract customers for their other goods, on which they make a profit. They do not expect to get more than actual cost for their jewelry, for they are not dependent upon its sales, as we are, to meet all their expenses. Buying at the lowest prices, they can afford to undersell us, because of the notoriety it gives them in the community. Their customers argue that if they can afford to sell jewelry at a less price than the regular dealer does, they must sell their other goods proportionately low. This is the club that is knocking out the brains of the legitimate retail dealers. Time was when manufacturers would have scorned to sell their goods to outsiders; they regarded it as their duty to protect the trade and to give those who had put their time and money into it an opportunity to make a living by it. But now every fancy notion store, every gent's furnishing goods dealer, the barbers, hardware merchants, and every one who wishes can buy jewelry as cheaply as the regular dealer, and undersell us because they make their profit on other things. It seems to me that retail dealers need such protection as the manufacturers and jobbers can give them, quite as much to-day as they ever did, yet I learn from the articles in THE CIRCULAR that a certain class of manufacturers have determined to continue selling to outsiders even though they sacrifice their trade with the retail dealers. My remedy for this would be to refuse to buy goods of any house that was known to sell to any outsiders. Let them keep all such trade, I say, and see how long they can do without the legitimate retail dealers. Your suggestion that we should add other lines of goods to our stocks, and supply the public with whatever it wants, is very good, but how are we to do it? I, for instance, have spent years learning the watchmakers' trade, and, having made the acquaintance of some jobbers, have set up in business for myself, with a small stock obtained on credit. How am I to get goods in other lines of trade where I am unknown, and where I have no credit? I should be very glad indeed to enlarge my business in this way, but I am not to

get the goods? I have been dealing in jewelry exclusively for several years, have paid my bills with as much promptness as circumstances would permit, and I feel that I have a right to be protected in my trade. Instead of this, I find those who should protect my interests are encouraging a competition against me that I cannot stand. As a matter of self interest the manufacturers should protect the jobbers, and the jobbers the retail dealers; instead of this we find them both stealing the trade of the retail dealer by selling to outsiders, either at wholesale or retail, at prices with which we cannot compete. This may be profitable to them, but it is ruin to us, and in the end must react upon those engaged in it.

RETAIL DEALER.

We give prominence to the above communication for the reason that it is a fair sample of many that we have received of late. It fairly represents the discontent that pervades the retail trade in consequence of their patronage being absorbed to an alarming extent by outsiders. That this is being done is well known, and that manufacturers and jobbers are responsible for this condition of affairs is equally true. Outsiders could not compete with the retail dealers unless they were afforded facilities for buying equally favorable to those given the legitimate retail trade. Why this is so we have discussed at length in previous articles, but may be briefly summed up by the statement that outsiders are, as a rule, more liberal buyers than the retail dealers, pay their bills more promptly, and, being better merchants, push their sales with more energy and enterprise.

The traditions and ancient customs of the jewelry trade are fast becoming obsolete, and, instead of the several branches of it co-operating for mutual protection, every member of it seeks to dispose of his goods to the best advantage, regardless as to who is the purchaser. Business customs in all lines of trade have changed very materially within the past quarter of a century in conformity to the progressive spirit of the age, and practices that are now common to all, would have made the hair stand on end on the heads of our conservative grandfathers. The retail jewelry trade has experienced changes quite as radical as has that of the manufacturing or jobbing branches. Formerly a retail dealer was expected to have reached that position after having served a long apprenticeship at the watchmaker's bench and several years longer as a journeyman; he was expected to have a fair amount of capital, generally saved from his wages, before asking for credit; he was expected to be a man of the strictest integrity, whose word was as good as his bond, and who was honored and respected in the community in which he lived. To-day the retail trade is crowded with men who are merely speculators in jewelry, having little knowledge of the goods they handle, and deal in jewelry as they would in flour or pork, simply for the profit they can make out of it. Many of these purely speculative retailers are wholly unscrupulous, and it is the compliance with their urgent demands for debased goods that has given birth to a class of manufacturers who make 14 karat goods out of 10 karat gold. Their principal capital consists of an unlimited amount of "cheek," by the use of which they obtain goods on credit with a view to a speedy failure and a cheap compromise with their creditors. There is still another class of retail dealers that is made up of botch workmen,

who, being possessed with an inordinate desire to acquire sudden wealth, are not content to learn their trade thoroughly, but knowing how easy it is to obtain goods on credit, they set up as dealers and repairers, being neither merchants nor skilled workmen. They are not fit to be trusted with goods to sell or with articles to repair, but have, by their botch work, brought much reproach upon the trade. Anything that will drive them out of it is to be hailed as a blessing. But there are many good workmen who have been tempted to set up as retail dealers, and have thereby made a great mistake. As workmen they were sure of permanent employment and good wages; they knew what their income would be, and what they earned was their own, to do with as they pleased. But as retail dealers, owing for their stock, the money they handle virtually belongs to their creditors, and they are kept in a constant state of worry and excitement to devise ways of meeting accruing indebtedness. They are out of their element, their incompetence as merchants making them uncertain and untrustworthy as workmen. Had they stuck to the bench and not incurred the cares and responsibilities of dealers, they might live in peace and contentment, an honor to their calling and respected by all who knew them, but having been tempted out of their depths, they are overborne by their responsibilities, and full of complaints of their lack of success. To such as these our advice to diversify their stock and sell the public whatever it wants, would be out of place. They have not the capacity or fitness to become merchants, and the deeper they wade into the pool of commerce, the worse they are off. Such as these are great sufferers from outside competition, for they have not the capacity to meet it. They should return to the workbench and good wages, and be satisfied with excellence in the position they are calculated to honor, rather than accept inferiority in a sphere to which they are not adapted, bearing in mind the old proverb that "contentment is better than riches." In the long run it will turn out that the competent workman is pecuniarily better off, richer in money, health and contentment, than the competent workman who is an incompetent merchant. There are hundreds of this class of workmen who are eking out a precarious existence as retail dealers, selling a few hundred dollars' worth of goods a year, who are always in debt and never knowing how they can meet their bills, who are a positive injury to the retail trade. Their small dealings and their constant asking of favors from their creditors have been largely instrumental in inducing jobbers and manufacturers to seek more enterprising and trustworthy merchants to handle their goods. It is safe to say that if retail dealers as a class were better merchants, more pushing in competition and more capable of taking care of themselves and their trade, more liberal in their purchases and prompt in their payments, the outsider would never have obtained the foothold they now have, or grown up into such dangerous competitors.

Retail dealers, to be successful, must be merchants in the fullest sense of the word. It is the business of merchants to supply the popular demand for goods, of whatever nature, and he who does this most effectually will be the most successful. We have heretofore pointed out various lines of goods that it is perfectly proper for a retail dealer to carry, and we have the unsolicited testimony of many who have tried this to the effect that it has improved their business wonderfully, the introduction of new and attractive lines of goods, enabling them to sell far more jewelry than ever before. One thing helps another, and the customer who comes in to look at a musical instrument or an attractive painting may be tempted to buy a watch, a ring, or a set of jewelry in addition. Our correspondent asks how small dealers are to obtain credit for a diversified stock. We reply that no man has a moral right to set up as a merchant in jewelry or anything else unless he has a certain amount of capital behind him. He who does so is pretty sure to be overtaken with disaster sooner or later, for the simple matter of interest will bear him down at last unless he has more good fortune than falls to the lot of the average man. The ease with which credit can be obtained in this country is the curse of commercial business. It has been asserted, and is gen-

erally believed, that the number of men who succeed in commercial undertakings will average about four in the hundred; all the rest fail once or oftener during their business careers. This is due mainly to the fact that they undertake to do business without the substantial backing of capital to start with. They commence on credit, continue on credit, and finally fall into the hands of their creditors. The creditor class take all the risk while the debtor class expects to make all the profit. This is contrary to the immutable laws of trade and commerce, and those are exceptional cases where it proves successful. But with a fair amount of capital at his back—sufficient to assure the creditor class that he is willing to share the risk of the venture—almost any man can obtain all the credit he ought to have in any line of trade, provided he can show a good character. So we say to our correspondent, if you have been in business several years, and still have no capital, and have failed to so establish yourself as to entitle you to confidence, it is positive evidence that you were not intended for a merchant, and the sooner you seek more congenial employment, where such talent as you possess will have a better opportunity to display itself, the better it will be for you and for the trade. If you are now obtaining credit in the jewelry trade, without any capital, you are getting that to which you are not entitled, and your creditors had better be keeping a sharp lookout for you—not that your integrity is in question, but that it is almost an impossibility for you to be successful when so badly handicapped.

We repeat what we have said before, the outside dealers have obtained so strong a foothold in the trade that it is impossible to dislodge them; the only remedy left retail dealers is to meet them on their own ground, diversify your stock, prepare to meet the public demand, make your stores attractive, catch the public eye, be enterprising, in short, fill the position you are ambitious to hold, and not be content to rattle around in it like a dry pea in a pod. You have not a monopoly of the jewelry trade by divine right, but you can secure it by your own industry and enterprise. Your success or failure rests with you. You have no business to attempt to be a merchant if the conditions are against you, but if they are in your favor it will be due to your own lack of ability to appreciate the situation if you are unsuccessful.

IN ANOTHER column we print a communication from an intelligent watchmaker and jeweler, who uses the signature "J. K. B." He shows that he has a keen appreciation of the baneful influence outside dealers are exercising upon the retailers, and also of the fact that the way to meet this competition is for retail dealers to diversify their stock, and carry such goods, of whatever nature, as the public requires. This branch of the subject is discussed very fully in another article in this issue. But "J. K. B." makes a suggestion at the close of his letter, which, we are confident, he has not "thought out" to its logical conclusion. He would have all the retail dealers of the country unite in the organization of a joint stock jewelry manufacturing company, to supply to stockholders, and stockholders only, special lines of goods. The plan is thoroughly impracticable for many reasons: First, not one retail dealer in a hundred could be induced to go into the scheme; second, such as did go into it would want to control it, and there would be a clashing of ambitions and interests at once; third, scheming adventurers would be sure to get control of the company and run it in their own interests; fourth, the public would have no more confidence in the goods manufactured than in those made by individuals; fifth, such a combination of dealers would antagonize all those who were not members, and excite them to ruinous competition; sixth, manufacturers would expend their energy in building up the outside trade, and the expense of the retail dealers. For these and other reasons, the scheme is not feasible. The field is too large to be covered by such a company, especially when it is satisfactorily occupied by the present corps of manu-

facturers, whose reputations are established. Co-operative movements of the kind suggested have been repeatedly tried in this country, and as often have failed, and must always fail when brought into competition with individual enterprise. The plan suggested would be an attempt to create a monopoly in the manufacture of jewelry, and monopolies are offensive to the sense of the American people. The manufacturers already in the field have altogether too much at stake to be elbowed out of the way by any such organization as proposed. Our correspondent will see, on reflection, that an attempt to carry out his impracticable scheme would be sure death to the retail dealers.

WE HAVE received a copy of the annual report of the Director of the Yale Observatory, Prof. H. A. Newton, to the authorities of the College. He submits, also, the report of Dr. Waldo, who has charge of the Horological and Thermometric Bureaus, regarding which he says: "The service which the Bureaus are doing to the community is of the highest value, and, I believe, will be more and more appreciated as it becomes better known." Dr. Waldo reports that during the year fifty watches were received for certification from different manufacturers. Of these eight received certificates of the first class, one of the second, one of the third, four of the fourth, nine remain on hand, and twenty-seven were returned as not fulfilling the conditions for obtaining any certificate. The conditions are very exacting, and have heretofore been published in THE CIRCULAR. Dr. Waldo says: "It has been suggested to us, from various quarters, that a school of Horology is needed in this country, similar in its scope and equipment to those abroad. It has been further urged that certain courses of the Scientific School could be utilized for the instruction of technical students in this connection, and some friends of such an enterprise are willing to furnish a part of the necessary plant. Before such an undertaking can be seriously considered by the proper authorities, it will be necessary that the endowment for at least two of the chairs of instruction should be provided for, and a sum of money for the incidental expenses of such a school be furnished by the friends of such an enterprise. A school of this character is no doubt needed by one of our leading industries, and it will not be difficult, should the financial support be furnished, to establish a course of study and manipulation which should lead to a certificate of training and ability in this direction." The Thermometrical Bureau issued 5,295 certificates for thermometers during the year, as follows:

- 21 with mercurial standards up to 100° C.
- 31 with mercurial standards up to 275° C.
- 12 with Yale Observatory standard thermometers.
- 1 with minimum meteorological alcohol thermometer.
- 51 with maximum meteorological mercurial thermometers.
- 39 with ordinary meteorological mercurial thermometers.
- 5140 with physicians' clinical mercurial thermometers.

THE DISTRESS at the Cape diamond mines is reported to be very great, and business there has been brought almost to a standstill. Following upon a failure of the crops of the country, which entailed great suffering in the agricultural districts, came the disaster in the diamond mines at Kimberley. The mine is 380 feet deep, and one and three-quarter miles in circumference. The soft debris has fallen back in the mine in such quantities that it is estimated that eighteen months will be required for its removal. Upward of 4,000 tons fell within twenty-four hours. The extent of the calamity can be judged by the fact that this celebrated mine has yielded £3,000,000 in diamonds a year. The effect at Cape Town has been most disastrous. The revenue has fallen off fifty per cent., and the mining shares have gone down seventy-five per cent. It is estimated that it will cost £250,000 to clear the mine. There are sixty-

five diamond mining companies, with a subscribed capital of £7,000,000, and of these companies only fourteen are paying dividends. Most of these mines are within a radius of 150 miles, and at an average of 600 miles from Cape Town. The extent of the commercial convulsion is illustrated by the great Central Diamond Company. It had a subscribed capital of £900,000, and paid taxes on £840,000. Two years ago the shares were rated at £360 each, but it is reported they are now worth only £80. The Freres' Diamond Mining Company at De Beers, a quarter of a mile from the Kimberley mine, with a subscribed capital of £130,000—£100 a share—has been sold out by the sheriff for £15,000 for rates owed to the Mining Board. Mr. Herm Wilegroot, a leading merchant, blew out his brains on account of all these troubles, and two weeks afterward Mr. J. R. Schonz, Resident Magistrate, killed himself. Altogether there have been about ten suicides of leading men caused by the commercial depression. The most terrible stories of starvation come from the copper region, especially from the neighborhood of the great Manamaculand mines. Commercial circles in Cape Colony are so greatly depressed that many of the colonists are returning to Europe and especially to England. This condition of affairs at the Cape accounts for the advance in price of standard goods. An English syndicate holds nearly all uncut goods in the market, and make their own prices, being careful not to permit goods to go out fast enough to break the market.

Jewelers' Day.

THE FIFTH annual reunion of the New York and New England Jewelers' Clubs occurred at Providence, on July 6th, on which occasion the New York Jewelers were the guests of their New England brethren. The annual gatherings of these representative Clubs mark festive days for the trade in general in the East, and are looked forward to with anticipations of pleasure by large numbers. Heretofore the main feature of the day has been a match game of base ball between the New York and Providence Clubs, but this year it was resolved to diversify the entertainment and thereby make it attractive to a larger number. How this was done will be shown further on in this report.

On the afternoon of the 5th, the New York Club began to assemble at the Astor House, and by four o'clock there were present 150 members and invited guests. Promptly at that hour the assembly was sounded and the members fell into line. It was observed that each wore a white straw hat with a blue ribbon and straw-colored gloves. The column was under the command of B. W. Ellison, President of the Club, assisted by H. J. King and S. P. Howard, Vice Presidents. Following these were C. W. Cooley, Secretary, and J. G. Fuller, Treasurer, and the members of the Executive Committee. The Seventh Regiment band, twenty-five pieces, under the leadership of A. C. Cappa, headed the procession. The line of march was down Broadway to John street, to William street, to Maiden Lane, to Broadway, to Warren street, and finally to pier 29, North River, and aboard the steamboat *Stonington*, which lay in waiting to convey them to Providence. In the ranks were representatives of most of the houses in the trade, and the appearance of the Club in marching order was greeted with continuous cheers along the line of march. They looked very fine indeed, and marched with the precision of veterans. Accompanying the Club as its guests were Messrs. C. A. Boynton and wife, G. Willemin and wife, S. P. Howard and wife, Wm. Bardel and wife, J. R. Palmer and wife, H. A. Desraimes and wife, A. Kurchborne and wife, St. Louis, and J. H. Morrow and wife. Having reached the boat, the members repaired to their staterooms and disposed of their baggage, which being done they speedily reappeared on deck to cool off, as their march had been made in the sun while the thermometer marked 90° in the shade. They gathered in congenial groups about

the decks and entertained each other with story and anecdote, while the boat steamed up the East River and the Sound. The trip would have been a most enjoyable one but for the uniform and chronic discourtesy and boorishness of the officers of the boat. Rudeness and impoliteness characterized them all from the captain, with his overpowering conception of his own importance, down to the steward, not forgetting the surly and curt clerk. It had been arranged with the steward that the Club was to be served with a *table d'hote* dinner at 7 o'clock, but the captain and clerk vetoed the arrangement without notice to any member of the Club. As a consequence, at dinner time there was a grand rush for the dining saloon, which is uncomfortably small, and but a small portion of the crowd could be seated at once. This resulted in a grand scramble for a seat whenever one became vacant, and instead of the hungry multitude being supplied in an orderly and speedy manner, it was nearly midnight before the last had been served. During the greater part of this crush for dinner, a special table was reserved for the autocratic captain, while several ladies were kept standing, waiting for seats. The discourtesy experienced from the officers of the *Stonington* was the only thing that occurred during the two days to mar the festivities.

It had been arranged that a concert would be given by the band and glee club during the evening, but the miserable failure of the dinner arrangement interfered somewhat with this plan. It was nearly ten o'clock before the musical programme was entered upon, and after midnight when it was concluded. The following was the programme:

PART I.

OVERTURE.....	BAND.
GLEE—"Where Would I Be".....	CLUB.
SOLO.....	FRED. STINES.
DUETT—"Larboard Watch".....	GOSLING AND HOLLAND.
SOLO—"Non-e-ver".....	C. BRAUNLICH.
SOLO—"The Old Sexton".....	W. P. STOWE.
GLEE—"Huntsman's Farewell".....	CLUB.

PART II.

SELECTIONS.....	BAND.
GLEE—"The Miller's Song".....	CLUB.
SOLO.....	G. C. BOOTH.
SOLO—"Simon, the Cellarer".....	FRED. STINES.
SOLO—"Sailing".....	MR. HOLLAND.
DUETT.....	STINES AND BRAUNLICH.

These selections were artistically rendered, to the delight of all on board, who expressed their enjoyment of them by unstinted applause. A dense fog coming up in the night, prolonged the trip somewhat, so that the boat did not arrive at Providence until 6 A. M. By that time every one was on deck, while on the dock stood the New England Club, ready to extend to them a cordial welcome to the city of Providence.

The New England Club wore white duck hats, gloves, and handsome badges. After the customary salutations, the ladies were escorted to carriages in waiting, while the members of the New York Club were soon seated with their hosts in open street cars, their baggage being transferred to an Adams' Express wagon, kindly provided by that company for the purpose. With the Seventh Regiment band discoursing appropriate music, and the cars decked with flags and streamers, the gay party was driven through various streets to Roger Williams' Park, where a substantial breakfast had been prepared for them at the What Cheer Cottage. The tables were arranged on the open verandas, and were tastefully decorated with flowers, etc. Before taking seats, President Potter, of the New England Club, made a short address of welcome, which was appropriately responded to by President Ellison in behalf of the New York Club. Breakfast, which was abundant in quantity, and most excellent in quality, was then partaken of, and especially enjoyed by those who had been disappointed in the matter of dinner the night before. F. I. Marcy and H. Howard had been appointed a Special Committee to take charge of the ladies, who were served with breakfast in a private parlor. Right here it is proper to say that the Committee addressed itself most assiduously to their fair guests throughout the day, contributing greatly to their enjoyment.

After breakfast, the members of the two Clubs amused themselves sauntering about the park, indulging in boating, singing and other recreations, including short rides in the baby perambulators. About nine o'clock the party resumed their seats in the open cars and were driven to headquarters of the New England Club, where they made the necessary preparations for the street parade. In the course of an hour the line was formed in the following order, and marched through several streets to the Union Depot:

Police skirmishers, Lieut. Dary.

National Band, Fred. Goodspeed, leader, 25 pieces.

New England Manufacturing Jewelers' Association: President, Alfred S. Potter, Vice-Presidents, E. H. Smith, R. S. Hamilton; Secretary, John A. McCloy; Treasurer, R. S. Hamilton, Jr.; Executive Committee, Wm. H. Luther, B. Woodbury Dodge, Oren C. Devereux, Chief Marshal, Nathaniel Grant; Adjutant, T. W. Manchester; Aids, Isaac L. Goff, J. A. Thornton; 175 men.

Invited guests and press representatives.

Barouches containing the ladies of the party.

Seventh N. Y. Regiment Band, A. C. Cappa, leader, 25 pieces.

New York Jewelers' Club: President, B. W. Ellison; First Vice-President, H. J. King; Second, S. P. Howard; Secretary, C. W. Cooley; Treasurer, J. G. Fuller; Executive Committee, Theodore L. Parker, John W. Senior, C. W. Cooley, R. A. Johnson, F. H. Bliss, J. Marks, E. A. Bliss; Chief Marshal, E. A. Bliss; Aids, E. Untermyer, A. Pinover, C. Buechner, Geo. Fenn, G. C. Booth; 150 men.

Invited guests and Associated Press Representatives.

At the depot a special train of cars was in waiting to convey the party to Oakland Beach, where the programme of sports was to be carried out.

Arriving at the beach, the line of march was resumed, leading directly to the dining room of the Mansion, kept by a most estimable caterer, who responds to the popular designation of King Hiram. Dinner was ready, and it took but a few moments for each person, host and guest, to secure a seat at the table. At each place was found a handsome souvenir of the occasion in the shape of a programme of the day's amusements, the cover being ornamented with a most excellent engraving of the head of Col. A. S. Potter, President of the New England Association. A package of fragrant Havanas also flanked each plate. The dinner provided was capital in every respect, that indigenous bivalve of Rhode Island, the juicy and succulent clam, comprising a central feature of the repast. The quantity of these that were placed where they would do the most good can only be estimated by the wagon loads of shells that were subsequently removed. It is said that King Hiram's dinners are always a success, and certainly this was no exception to the rule. The ladies were specially served, at a special table, by the special committee having them especially in charge, and were specially well served by these two special ornaments of the trade.

After dinner the programme of amusements was entered upon, and games of base ball and foot ball were at once improvised by those who are devoted to these sports. The majority, however, gathered about the lake to witness the single scull races, for which there were eight entries. Captain B. L. Hall, the referee, decided that the race should be rowed in heats. Messrs. Nelson S. Davis and Asa Richmond, Rising and Van Dorn, Kingston and Eslick, Wilkinson and Stone, rowed in pairs, and Messrs. Davis, Van Dorn, Kingston and Wilkinson were the respective winners. It was finally decided that Messrs. Davis and Wilkinson should row the final heat, the distance being a half mile, and Davis won in 3 minutes 53 seconds, Wilkinson coming in three seconds slower. The starter was Frank T. Pierce and the judge at the turn B. F. Crossin.

While the race was going on, Mr. Max Stirn astonished the multitude by his daring equestrian feats on the bare back of a fiery untamed steed of the desert attached to a merry-go-round. His agility was something wonderful, while the ease and grace that marked every movement aroused a feeling of envy in every manly bosom.

A foot race over a twenty-five yard course was the next thing in order, for which eight ambitious pedestrians competed. This was won by T. Brush in 12 seconds; Pitts, pitcher of the Providence nine, being a good second. These gentlemen showed an ability for getting over the ground that would cause their creditors some anxiety if they were not so well known.

Much amusement was occasioned by the tub race, in which four aquatic members of the associations competed. The contestants showed much ability as commanders of sea-going craft, and handled their frail vessels with the dexterity of old salts. Max Stirn and B. L. Hall were the favorites, Hall winning after a close rub and a slight collision on the home stretch. No one asserts that Hall purposely ran into his opponent's tub, but the fact that the collision gave him the race is asserted by the backers of Stirn—but for that, Mr. Hall would certainly have had a Stirn chase. The winner was the recipient of a handsome medal especially prepared for the event. Alex. Pinover, being unable to keep afloat in his tub, was consequently the last man in the race, and was presented with the tubs as a recognition of the fact that he had Pinoverboard more times than any of the others.

Next followed a sack race, for which four of the club men, regardless of their personal appearance, encased themselves in sacks, and undertook to run, walk, roll, hop, tumble, skip, straddle, jump, waddle, wobble, go-as-you-please, over a certain distance. Their antics were amusing, bringing forth side-splitting shouts of laughter from the spectators, as they floundered over the ground, tumbling over each other and rolling in the dirt. Ed. Fiske, of Providence, was finally declared the winner, he having covered the distance in the shortest space of time, with fewer mishaps and less damage to his clothing than any of the others.

There was, also, ten-pin playing and target shooting for those who enjoyed these sports, and the inevitable foot ball was constantly putting in an appearance whenever it could discover a social group, at the most unexpected times and unannounced manner. During all these sports, the two bands relieved each other in the rendering of enlivening and appropriate music, contributing thereby largely to the enjoyment of the occasion.

An amusing feature of the festivities was a mock trial. Criminal charges were preferred against Mr. Allen, one of the proprietors of the Astor House, and it was decided that he must be tried immediately. A warrant was placed in the hands of Police Lieutenant Dary, and he at once arrested Mr. Allen, and, followed by a large crowd of the jewelers, preceded by the Seventh Regiment Band, he was escorted a prisoner to the refreshment pavilion, where he was placed in the prisoners' dock, a chair mounted on a table. John W. Senior officiated as Judge Advocate, Nathaniel Grant was assigned as counsel to the prisoner, Theodore L. Parker was assistant counsel, and G. C. Booth was prosecuting attorney. The charges were then read to the culprit, in which he was accused of wearing a hat of a different variety from that required by the New York Club; also of having refused to eat clams at dinner; and, further, of having partaken too generously of Pawtuxet water. The prisoner pleaded not guilty, but offered to give his watch and chain, all his jewelry and whatever money was secreted about his person, if they would let him go. This was refused with scorn and howling, and the trial proceeded. Various witnesses were summoned, and questioned in a humorous manner by counsel on both sides as to the nativity, childhood, and business habits of the accused, as to his social proclivities, his domestic relations, and all manner of irrelevant things, to which witty answers were given, which left the character of the culprit very much obscured. The counsel had animated arguments over different questions of law and evidence presented, during which their imaginations ran riot, and made confusion worse confounded, adding to the hilarity of the occasion. It was an exceedingly amusing episode, and was enjoyed by none more keenly than by the innocent victim of the conspiracy. It having been conclusively proven that he had been seen in possession of a policeman's hat, he was declared guilty of the first specification. When the question arose as to whether or not the prisoner had refused to eat clams, he put in evidence his abdominal rotundity, and this, together with the fact that a clam shell was found on his person, was regarded as satisfactory proof that he had eaten clams, and he was found not guilty of the second specification. While counsel were wrangling over the evidence as to his

drinking Pawtuxet water, friends of the prisoner hustled him down out of his chair and aided him to escape from his persecutors. The various gentlemen engaged in the trial acquitted themselves brilliantly, and gave proof of the fact that they are gifted with ready wit and a keen appreciation of humorous situations.

During the afternoon Senator H. B. Anthony appeared upon the scene and was accorded a warm and pleasant reception. The glee club sang a choice selection of songs, in a manner highly creditable to its members, at intervals during the afternoon. It was a most enjoyable day to all who participated, there seeming to be a never-ending variety of sources of amusement. Before breaking up, the ladies held a little convention of their own, and passed a vote of thanks to Messrs. Howard and Marcy, who had been so devoted in their service during the day, and to the Association for the very pleasant entertainment they had received.

At about six o'clock, the party again took the special train for the city, and thence to the boat. The scene at the dock as the boat departed was a lively one, good-byes and good wishes passing freely from one Club to the other and many hearty cheers for each other. The New York Club was so thoroughly exhausted that they retired to their staterooms as soon as the boat got out of hailing distance of the dock, and nothing further occurred worthy of note till their arrival in New York next morning, when they bade good-bye to their guests and separated, each returning to the accustomed routine duties of his daily life. This was unanimously declared to be the banner excursion of the series, the most enjoyable because of its variety. Not an incident occurred to mar the festivities save the discourtesy of the officers of the *Stonington*, and for that the Club was not responsible. Everything passed off smoothly and without friction, and the proprieties were observed to an extent that would have elicited the approval of the most fastidious lady or gentleman. Jewelers' Day is becoming more popular with each recurring celebration of it. It is a good thing for every one to unbend occasionally in social relaxation, to cut loose from business cares and anxieties, and to give free rein to our animal spirits. So long as these recreations are innocent and harmless, they cannot fail to benefit every participant in them. It is the determination of the Jewelers' Clubs to make the sports of Jewelers' Day enjoyable without roughness, and entertaining without coarseness, and to exclude everything and everybody whose admission would tend to make them otherwise.

Proceedings of the Horological Club.

A DISTINGUISHED BODY OF WATCH AND CLOCK MAKERS.

One hundred and tenth Discussion.—Communicated by the Secretary.

[NOTICE.—Correspondents should write all letters intended for the Club separate from any other business matters, and headed "Secretary of the Horological Club." Direct the envelope to D. H. Hopkinson, Esq. Write only on one side of the paper, state the points briefly, mail as early as possible, as it must be received here not later than the eighth day of the month, in order to be discussed and reported in the CIRCULAR for the next month.

ELECTRIC SECONDARY DIAL CLOCK.

Secretary of Horological Club:

I have just completed and set up an electric clock, or rather a secondary dial, for my show window, in a simple and compact form, which is working very accurately and successfully; a description and directions for making one may be interesting to some of your readers. The dial is of ground glass 30x36 inches (the extra six inches being for name below the circle). It has seven $\frac{3}{16}$ -inch holes drilled through the glass, one at each corner, to suspend it by, one in center for hands, and one $1\frac{1}{2}$ inches each side of center, to fasten movement to dial; these holes are easily drilled with a diamond drill in the bench lathe; the diameter of circle of figures is 28 inches and the figures 5 inches high. From an old clock movement I took the center arbor with pinion attached, also the minute and hour wheels; then turned a disc of thick brass two inches in diameter, cut sixty ratchet teeth on it, and staked it on the center arbor. The dia-

gram shows the simple construction of the machine; *a* is the lower plate, 3x4 inches of thick brass, drilled and tapped with two holes to fasten to dial; the minute wheel is pinned to a stud in the plate under the ratchet driving wheel *b*; the top plate is represented by the dotted lines, and supported by four pillars, *c c c c*; the electro magnet is secured to the lower plate, and sets out from it $\frac{1}{4}$ inch; *e*, the armature, is pivoted to the plate by two conical pointed screws

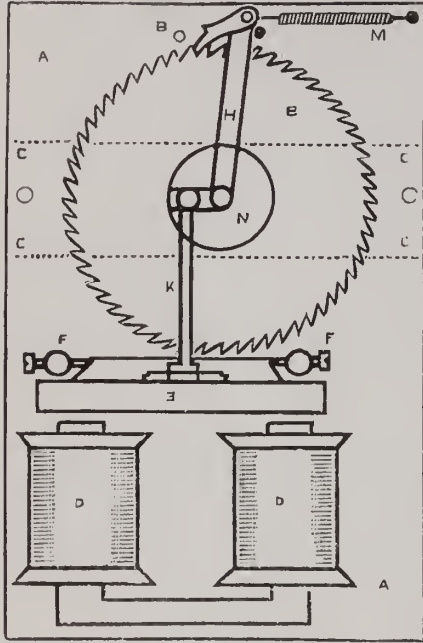

passing through brass posts, *f f*, set in lower plate. I have tried several forms of ratchets, but like the one represented here the best. The lever *h* is soldered to disc *i*, $\frac{3}{4}$ inch in diameter, and both drilled through together to turn on the center arbor, to which they are secured by a collet driven on above them; the connecting rod, *k*, must be jointed at the lever and also at the armature, but in opposite directions. In making the ratchet great care must be taken to have the point the right shape, so that when it receives the impulse from the armature it will be driven under the pin *l*, and strike it in the corner formed by the small shoulder, and prevent the ratchet raising up, otherwise the wheel will be driven by the impulse received more than one tooth at a time. A fine spiral relay spring, *m*, draws the ratchet back and raises the armature; also a spring, *n*, rests on the edge of wheel having an end shaped like the ratchet teeth; this holds the wheel in place as the ratchet is drawn back, and also insures an equal division. The depth of the armature from point of pivoting to center of magnet is about $\frac{1}{2}$ inch, and should not draw over $\frac{1}{8}$ inch (less is better) at its widest point. The lower side of the armature should be covered with a piece of thin silk glued on to prevent its touching the poles of magnet. The clock should be circuited with a regulator, or any clock having a seconds wheel, by drilling through the rim of the wheel that revolves once a minute and inserting a small gold or platinum pin, then insulate a very fine, light gold or platinum spring from the movement by screwing it to a little block of hard rubber, and that to the movement, and bend the spring so it will just touch the pin as it revolves, once a minute. The lighter this connection is, the better. Connect this spring with one pole of a Leclanché battery (I am using two cells with my clock), and the other pole of the battery with one of the magnet wires on dial; then fasten another insulated wire to the lower plate of regulator movement, and connect it with the other magnet wire of dial, which completes the circuit; the hands must be made of thin iron or steel and the minute hand accurately balanced. In hanging the dial it is necessary to glue small blocks of wood to the face to prevent the hands from touching the window glass; in the night time, with a light in the store, the dial becomes a very conspicuous object from the street. I should be very glad to hear from any one else who is interested in either electric clocks or secondary dials.

J. H. S.

Mr. Electrode said the arrangement described and illustrated was very simple and effective, and would drive a secondary dial not only in the store window, but on a post outside, in a tower, or another building. It would also drive church clocks, town clocks, and other public time pieces, instead of having costly movements to move the hands. But the great trouble with all electric clocks is in the part which Mr. S. has not very fully explained, viz.: the connection with

the governing clock or regulator. If the spring or the pin on which it rests should get rusty, greasy, or dirty, so that there is not a good metallic contact between them, the current would not pass through the circuit, and of course the hands of the secondary dial would not be moved at the proper time. Even a hair, or a little fuz, would be sufficient to prevent this contact. On the other hand, a little moisture, a bit of wire or foil, and many other things, might make a passage for the current between the two wires, even without going through the spring and pin at all, in which case the hands would stand still, or would jump whenever the wires touched each other, regardless of the arrangements intended for making contact and moving the hands. In a window sign, however, an occasional failure would not be a very serious matter, and might be overlooked. Those who desired to run electric clocks would find further information and cautions in our Proceedings several months back. With regard to the glass dials, they could be bought ready made, of different sizes. The maker's address could be found in the advertising pages.

THE TRIPLEX ESCAPEMENT OR "DOUBLE IMPULSE CHRONOMETER"—
ITS INVENTOR MADE KNOWN.

Secretary of Horological Club:

I notice in your May number the cuts of the Triplex Escapement, with description of the working parts, as published by M. Grossmann, and suggesting its American origin. Thinking that a further history of it might be of interest to your readers, and also to bring to your notice the watchmaker who invented it, I will state that an American, Mr. W. H. Lamb, of San Francisco, Cal., invented and patented it about twelve years ago. A Mr. Carl Hain ordered six of them in Switzerland, but after being finished and before shipping them, Mr. Hain either died or failed in business, and the patentee being unable to pay the cost of manufacture, they were disposed of in Europe. They were to cost about \$250 each, cased in gold, and finally jeweled. In 1880, Mr. Lamb and I built one and exhibited it at the Mechanics' Fair of that year, held in San Francisco, and in some respects improved on the original. We pivoted and balanced the detent lever, and jeweled its bearings, using a small, coiled hair spring for tension on its staff; also eccentric banking pins; also a small roller instead of crescent impulse arm, and a third independent tripping roller with an angular projection, which unlocked and quickly passed the detent. Although complicated and difficult to make without special tools, yet it had several good qualities that offset its extra cost. It had a good strong motion, and it was difficult to stop the balance in any position but what it would start of itself, and without moving it, resembling in that respect a well made Lepine. It could not be made to "gallop," or gain a beat, having to return before a tooth could pass the double rollers. Horseback or railway riding had no more effect on it than on a lever watch. I have the watch that we made in my possession yet, and the inventor calls it the Double Impulse Chronometer.

R. R. MORRISON.

Mr. Uhrmacher expressed his pleasure at being able to publish the name of the inventor of this interesting escapement. It would be remembered that it was one of the class of detached escapements, or those in which the balance receives a short impulse from the escape wheel, and then continues its vibration, entirely detached or free from the train. The ordinary chronometer is an example, but receives its impulse only in one direction, or at each alternate vibration. The triplex escapement is so constructed as to give the balance an impulse in both directions, and receives its name from the fact of having three wheels on the escape wheel pinion—two impulse wheels and a detaining wheel. This construction renders it somewhat complicated and costly, but it is claimed to be free from setting and galloping, the great faults of the ordinary chronometer. While the inventors of horological improvements do not, as a rule, make much pecuniary profit from their productions, they should at least have proper credit for their inventions, and we are glad to give it in this case. We should be pleased to hear from other inventors, describing their improvements, in any of the branches of our trades.

HOW TO MARK WEDDING PRESENTS.

Secretary of Horological Club:

Will you please inform me how wedding gifts should be marked?

Should they have the bride's initials as they were before marriage, or after? A reply will oblige
J. C. D.

Mr. Clerkenwell said that he had a most decided opinion as to what should be done with wedding presents. He also remarked that he had noticed that his wife made a practice of reading the Proceedings of this honorable body every month. With regard to marking wedding presents, he considered that his most private, innermost opinion belonged to himself, and he preferred to keep it where it belonged, as being, all things considered, the safest way to do.

The general opinion among the trade was that it depended on circumstances. Viewed from a legal standpoint, they should be marked with the initials after marriage. As the wife is a legal nonentity, they should bear the husband's initial. Both being one, and that one the husband, there is but one mark, legally, and that is the husband's initial. If not so marked, they would not be marked at all as wedding gifts, but would be gifts to the bride as a girl, (or otherwise, as the case might be).

But as the law would seldom be invoked in such a matter, the case might be looked at from another point of view, that of expediency. For instance, if the bride proposed to wear the breeches, it might be advisable to mark with the initials of the boss, on the universally accepted principle of "Any way to have peace in the family." For the same reason, the "powers that be" should be "seen," with reference to what would be most proper and fitting, before marking presents. If that would be too delicate, there is always the mother-in-law, who would be only too glad to act as go-between, and who would, *of course*, consider everything strictly private and confidential, and to be forever kept secret, and never told to anybody whatever—till after the wedding. If there was, for a wonder, no mother-in-law, there surely would be some big brother, or little sister, or an aunt, or cousin, or something, who could be consulted.

Then again, a great deal depends on what is to be done with the presents after the ceremony is safely over. If they are to be sent to some dealer in duplicate wedding presents for sale, or to be exchanged for something that suits better, or given to somebody else as wedding presents for them, then it were better not to mark them at all, so they can pass from hand to hand, and do service over and over again, and spread happiness throughout the land, so to speak. On the whole, there are so many ways of looking at the matter, and so many things to be taken into consideration, he thought he would have to tell Mr. D. that he believed he didn't know what was best to do about it, and if he did he had rather not tell, unless he knew the parties. The safest way for the trade is to assure their customers that the fashion is not to mark presents at all till after the wedding, and so let the husband and wife fight it out between themselves.

Aristarchus Plumbago and the Flop-Over Button Brigade.

WHEN I last wrote you I gave you some idea of the great Stoneville boom that was raging in the west, and explained how certain large capitalists had resolved to make of Stoneville the center of the watch, clock and jewelry manufacturing industry. Stoneville, in short, was to be the heart of the jewelry business, and its daily throbbing was to send forth through every artery of our commercial organization a deluge of goods that should flood the world. Here are to be manufactured watches, clocks and jewelry in quantities sufficient to supply not only the world, but the entire universe, and to give every male angel a gold watch and chain, and every female angel diamond ear rings, a gold necklace, and silver bangles for her arms. Naturally I made the acquaintance of these capitalists, and by a happy use of that native eloquence of which I am such a large proprietor, I soon convinced them that I was a necessary adjunct to their establishment—that without me they must fail, but with me the enterprise could not be other than a great success. I easily persuaded them that when their factories were in operation, giving employment

to thousands upon thousands of men, women and children, their daily products, amounting to tons of articles of use and ornament, made of the precious metals and stones, it would be necessary to have a Repository for said articles, where customers could call and make their selection. These far-sighted capitalists saw the force of my suggestion, and at once proceeded to erect, simultaneously with the construction of their watch, clock and jewelry factories, a large and attractive structure for the storage and sale of Stoneville's rich products. I was made Superintendent of "The Stoneville Mammoth Repository and Disbursing Agency of the Stoneville Watch, Clock and Jewelry Manufacturing Company." Before the factories were completed—indeed the foundations were not yet laid—the Repository was finished. I had it furnished with fifty large fire and burglar proof safes, with fourteen rows of shelving extending entirely around the interior of the structure, which shelving, if laid end to end, would reach seven miles and a fraction over; there were, in addition, nine miles of show cases distributed throughout the Repository in most attractive positions. Fourteen gentlemanly and courteous assistants were assigned to me for duty, and my *sanctum sanctorum* was connected by telephone with all the principal cities in the Union, in order that customers might communicate directly with me, and thereby insure promptness and dispatch in the filling of their orders for the superior and unexcelled goods that are to be produced by the Stoneville Company.

The Repository, under my intelligent and skillful direction, was speedily in a condition for the transaction of business, but, alas! the factories were still "in my mind's eye, Horatio,"—in other words, they were not built, and there were no goods, either useful or ornamental, to display in the exceedingly attractive Repository that had arisen as if by magic at my command. To be sure the builders had not been paid, and the decorators were threatening to attach the show cases, safes, etc., but this did not disturb me in the least, for I was not responsible. All such I referred to those capitalists whose subscriptions to the stock of the company amounted to several millions of dollars, and whose names looked so seductive in our prospectuses. There were also certain natives of the place who claimed remuneration for the vile food and viler liquid decoctions with which they had supplied myself and fourteen assistants, but these impatient Stonevillians I also referred to those capitalists who could never be found at their advertised places of business. The Repository being ready for business, but there being no goods to either sell or watch over, I was conceived of a brilliant idea, and forthwith delivered myself of it. If the Stoneville Manufacturing Company could not supply me with goods, why should not those persons who were already in the business, and whose travelers scour the country in search of victims to buy their goods? Filled with the magnitude and glorious promise of this magnificent idea, I telephoned to Chicago, and had the following advertisement inserted in all the papers:

WANTED.—A large stock of jewelry. Agents of manufacturers are requested to call without delay at the Stoneville Mammoth Repository and Disbursing Agency of the Stoneville Watch, Clock and Jewelry Manufacturing Company, Stoneville.

The advertisement appeared on Wednesday morning. On Thursday morning, in company with my fourteen gentlemanly and courteous assistants, I strolled leisurely down to the Repository, and what a sight greeted my astonished vision. Surrounding the Repository there sat two hundred and seventy-nine commercial travelers seated on two hundred and seventy-nine sample boxes. They greeted my appearance with the wildest demonstrations of joy, and each one of the two hundred and seventy-nine was determined I should examine his samples first. One frantically seized me by one arm, while another pinned me close by the other; three took possession of my button holes, and several appropriated my legs, while every other portion of my rotund anatomy was struggled and fought for by these eager, gentlemanly, but demonstrative travelers. They swarmed upon me like bees on a darkey's head; they multitudinized me; they overwhelmed me, they crushed me with their kindness

and importunity. I was finally rescued by a regiment of militia and conducted to the Repository. Having recovered from the embarrassment into which I had been thrown, I gave directions to the sentinels at the door to admit these impulsive travelers one at a time to my presence. The first to present himself was a voluble, energetic, persevering and perspiring gentleman, a strongly marked blonde. He addressed me in a sort of a two-drinks-for-a-quarter tone of voice, about as follows:

"I desire to show you my samples of the Bird-of-Liberty flop-over-and-get-back-easy sleeve buttons. They are the only sleeve buttons in the market that are patented, never get out of order, unequalled in variety, style, workmanship and finish. Millions of them are sold every minute. There is no limit to the number you can sell in this locality. How many gross shall I take your order for?"

I told this voluble and fair-to-look-upon young gentleman that I was much pleased with his vocal acquirements, and thought he ought to be an opera singer, but as he preferred to sell "Bird-of-Liberty sleeve buttons," with the established character of which goods I was well acquainted, he might send me as soon as possible ten thousand gross of them, assorted sizes and varieties, and be prepared to quintuple the order every week. The fair youth with a bland smile entered the order in his book and departed.

The next person introduced to my presence was a slim, languid youth, wearing a high standing collar and an eye-glass screwed into his left hand optic. I felt confident he represented one of the large diamond importing houses of New York, and prepared to receive him with the greatest suavity. He addressed me languidly with a sort of a How-do-you-like-me-coat,-Brown, inflection, and said:

"I have come down at this unseasonable howar of the mawning to show you my sarmples of the Great American Shanghai flop-over sleeve buttons. They positively are the only sleeve buttons that are covered by genuine patents. We make them in every variety of style, and every style of variety. They are the only sleeve buttons that flop-over-and-get-back-of-themselves that are in the market. But as I see you know the goods I will not fatigue myself fawther by expatiating upon their unapproachable excellence, but while I have sufficient strength left will enter your order."

I assured the gentle but fatigued youth that I was well acquainted with the Great American Shanghai flop-over buttons, and he might send me a thousand dozen gross a week for the balance of the year. One of my assistants led him fainting to the door, and he was lost to my vision.

My next visitor was a short, thick set, black haired young man, having much abdominal rotundity, and a decided smell of the stables. I was certain he represented one of those large firms of gold goods manufacturers, who keep horses; and prepared myself to feast my sight with beautiful specimens of artistic workmanship in gold goods. The rotund youth opened his sample case with a flop, and addressed me in a I'll-bet-yer-five-to-one-on-the-gray-mare tone of voice, substantially as follows:

"Here I am with no end of samples of the Slymax sleeve button, the only real, genuine, orthodox, flop-over-and-come-up-on-the-other-side sleeve button, manufactured for the legitimate trade only, never sold to outsiders, and guaranteed to have all the advantages of every other kind of button and none of their defects. The Slymax is covered by twelve distinct letters patent, each one tied with a yard and a half of blue ribbon, and warranted to be the *ne plus ultra*, the *e pluribus unum*, and the *fagh na ballagh* of all sleeve buttons. They are double jointed in the back and warranted not to cut in the eye. They go in with a twist of the wrist and a turn of the ankle, and come out when you whistle to 'em. How many will you have? Our factory is kept running night and day to supply the demand. Send in your orders early; first come, first served. How many did you say?"

Here I broke in upon the volubility of his rotundity, and being somewhat faint and discouraged, I gave him the same order I had

his predecessor—a thousand dozen gross a week for the rest of the year—and had him shown out—gently but impressively.

After this contact with the sleeve button travelers, I felt the need of some refreshments, and so called for some liquid sustenance which I always keep conveniently at hand. A copious draught somewhat revived me, and I directed the guards to admit the next visitor. This proved to be a pleasant, affable, smiling gentleman, somewhat corpulent and oleaginous and one who was evidently designed to fascinate the ladies. I was certain he was the diamond man. He addressed me in dulcet support-me-Chawles-or-I-shall-faint tone of voice, to the following effect:

"I wish to call your attention, sir, to this beautiful lay-out of world-renowned, universally celebrated, and never-to-be-eclipsed Stand-off flop-over sleeve button." [Horrors! I exclaimed mentally, is this another of 'em?] He continued: "The attractive feature of this make of sleeve button is that it is patented—patented, sir, by the United States of America. The patent office has given us a certificate which implies that it is unique, that there is nothing like it. It is the greatest invention the intellect of man has ever produced. In principle it is different from all others, but all others are like it in principle. There were other flop-over buttons before this was introduced, but there are none now; the Stand-off has superseded them all, and it is patented. No one makes them but our house. Millions of gross are sold every day. This button is high pressure with a shut-off valve, link motion, with elliptic springs and rubber buffer; the joints are gas proof and water tight. How many dozen will you take? Send 'em right away—telegraph the house at once."

Faintly and disconsolately I renewed my order for a thousand dozen gross weekly for the remainder of the year. The gentleman having been shown out, I took a little more refreshment and prepared to receive the exhibitors of other lines of goods. A brisk, breezy youth entered, and in a come-down-with-your-order-old-fellow tone of voice, addressed me:

"Here are samples of the Complex sleeve button, the only genuine flop-over-get-up-and-git button in the world. It is an antidote to lightning, a sure remedy for all diseases, cures delirium tremens, is the best sort of bait for fishing, and is covered by sixteen patents. It has a galvanic battery in the shank, and a small receptacle in the shoe plate for carrying cloves. The spring is a double back-action, with a somersault attachment, and a flip-flop compensating balance to the flop-over. How many will you order?"

Rousing myself from the stupor I felt stealing over me, I faintly ordered a thousand dozen gross every week for the rest of the year, and while one assistant showed the young man out, another sought to revive me with liquid stimulant, while another chafed my hands and laved my fevered brow. Feeling that I should be tolerably well stocked up on sleeve buttons, I braced myself up by picturing to my mind the magnificent display of valuable goods the other gentlemen in waiting must have to exhibit to me. My next visitor was a bland, oily person, wearing spectacles, a white necktie, and a chronic smile. He opened his sample case, and, in a sanctimonious hold-the-fort tone, addressed me thusly:

"These are the celebrated More-better-as-good flop-over-turn-around-and-come-back-through-the-same-hole sleeve buttons, which are patented in every country in the world. They are made up of all the best qualities other inventors forgot. They are mounted on turn-tables, have open nozzles, with thumbscrew attachments, and can be converted instantaneously into a Guild stamp or a fire-escape. How many did you say?"

Too much overcome to speak, I made signs to an assistant to give him the same order I had given the others. He departed, and a stimulating beverage soon brought me into condition to receive the representative I expected from the fine gold goods house. A perspiring gentleman, with an illuminated face, was shown in. With a conciliatory wink, and voice which implied I'll-take-a-little-sugar-in-mine, said:

"I beg to call your attention to these exquisite samples of the

Revival invisible-flop-over-and-come-around-the-corner-smiling sleeve buttons. Each one has an inexhaustible bottle concealed in the shank, and a liberal supply of medicated paper in the shoe plate. There is also a music box concealed in the stone settings that plays 'One More River to Cross' and 'We Won't Go Home Till Morning' in unison. The effect is soothing, cheerful and edifying. The boys are wild for 'em. All improvements patented. How many shall I send you?"

I had fallen from my chair in utter exhaustion, but my assistant gave the same order as before, and again resorted to liquid restorers to bring me to myself. Confident that the flop-over button men had at last been exhausted, I was prepared to receive my other visitors. A small, gentlemanly individual was the next to appear. Without hesitation, he began:

"Look at these samples of the Yank-ye-out-of-bed-at-daylight-flop-over-and-get-right-back-again sleeve buttons. This button is full jeweled, is a starter, a stopper and a fly-back all in one, appropriate for horse races, and will make you win every bet you make. It is popular with politicians, who propose to call in the trade dollars and issue these instead. Patented, sir, in every joint, clasp and buckle. How many?"

When I recovered, after a brief libation, he had gone, but had booked from an assistant the same order as the others. With many misgivings I gave orders for the admission of the next. He unfolded his samples, and, in a far-away-Rhode-Island clam-bake tone of voice began:

"These are the only genuine Improvident flop-over-automatic-unscrewing-go-down-one-side-and-come-back-over-your-shoulder sleeve buttons. They are patented because of the secret of the alloy of which they are made. Nobody but the manufacturer knows how little gold there is in them. They will assay more to the square inch——"

P. S.—Mr. Eddeter—Arasstarkis Plumbager has been took to the Lunatic Assylum, and I mail this letter just as he had it rote. They is 617 flop-over sleeve button men a-waitin' fur him to cum bak, all a-settin on their little boxes round the dore, and more uv 'em a-comin by every tran. Thay've ben fitin with the perlice and the sogers, and thay's lots of fun here.

JAMES MULHOOLEY, Office Boy.

Practical Treatise on the Adjustment of a Four Jewel Cylinder Watch.

[First-Prize Essay by HERMANN HORRMANN.]

In August, 1879, the *Allgemeine Journal der Uhrmacherkunst* offered a prize of 100 marks for the best essay on the adjustment of a four-jeweled cylinder watch, to be competed for only by journeymen watchmakers. Similar prizes were offered for second and third best essays. The second essay, by Vincent Lauer, was published last year in the JEWELER'S CIRCULAR. About 40 different essays from all parts of the world were received, and the majority of them gave indications of mature reflection on the subject by the authors. Messrs. Moritz Grossmann of Glashütte, J. Gebhart of Munich, F. W. Ruffert of Döbeln, Moritz Weisse of Dresden, Julius Thieme of Leipsic, Paul Bruckmann of Leipsic, and F. Rosenkranz, editor of above horological journal, constituted the prize committee.

ESSAY.

CHAPTER I.

PRELIMINARY EXAMINATIONS.

1. Every neat workman, before he undertakes a fresh piece of work or adjustment, clears his bench by removing all objects except the most necessary tools, such as keys, screw-drivers, tweezers, etc., because order and cleanliness are the prime conditions with all works of the watchmaker.

If paper is used to work upon, then the old sheet, in case it should no longer be thoroughly clean, is to be replaced by a new one. Tweezers, screw-drivers, (the watchmaker should always have a well assorted set of the latter on hand, suitable for different sized screw-heads—brass screw-drivers are with preference used for new watches) and all other tools and utensils, should always be in good working condition, since only with good tools a satisfactory piece of work can be performed.

It is an old saying, and a true one, that the bird is known by its feathers, which may truthfully be paraphrased to suit the watchmaker.

2. In order to prevent the confusing of screws among each other, the workman should have a small screw receptacle, in the shape of a small bench, in which the screws are placed in the same order in which they are removed from the watch. Small working boxes provided with partitions and covers serve for receiving the watch parts.

It is another condition that his hands be clean and dry from perspiration; if sweaty, they must repeatedly be washed.

3. When taking up a watch for adjusting it, perhaps the first glance will fall upon the dial, and it will be seen at once whether it stands straight, that is, whether the XII above is exactly in the center. We will recur to removing such a defect further on.

4. The case is scrutinized next, whether the pendant is securely fastened, whether improvements or changes have to be made in the closing or at the joints. These corrections can be attended to before the actual taking down of the watch, so that the case may be laid aside during the labor on the movement. If the pendant is not fastened securely, because the screw does not draw well, it is taken off; in case of necessity the ends are corrected, that is, they are filed sharp, or provided with pivot like shoulders, or a new, well-fitting screw is made. The pendant is next bent together by means of strokes with a wooden hammer, and sprung again into the steam head, for which purpose a pendant tongs may be used to advantage.

After screwing in the pendant screw, neither its head nor thread end must be allowed to protrude, since these parts would easily catch in the pocket, or they might injure the possessor's fingers.

5. The joints must close well; its ends are to be round, not sharp, so that they may produce no dust in the pocket, to penetrate into the watch.

The case must close firmly, but not in such a manner that some tool is necessary to open it. No circumspect watchmaker will buy watches with loose, unduly easy closing. If the case closes extra tight, seek to remedy the fault by rubbing on wax and opening and shutting repeatedly. Should this not correct it, a few taps with a wooden hammer on the joint and round the bottom will generally remove the obstruction. Remember, however, not to do this as long as the movement is in the case. If the firm closing can be corrected in no other manner than by hammering, do it after the movement has been taken out.

Many watchmakers use an appropriately-shaped graver, and take off the sharpness from the inner case closing on the cover, thus equally attaining their object.

6. Go carefully to work when examining the bezel closing, since it occurs quite often that the dial is too large or too thick, or does not lie flat by reason of protruding screw ends, whereby it is easily broken out at the joints or cracks.

If the dial is too large, it is to be filed or ground smaller on its circumference with a sharp, flat file, with fine cut, or an emery file. It is well to let the strokes of the file go from the middle of the rim to outside, and to moisten the file with oil of turpentine. In case the bezel or the joints are bad, it is best to consult a skillful case-maker.

7. The closing of the dust cap is left rather strong, to prevent the useless and frequent opening and shutting by the owner, thus protecting the movement against dust. The square of the center-staff must sit a little within the dust cap, since it is frequently apt to press against the case bottom of flat or thin gold cases, thus causing a disturbance of the hands; it is also advisable to make it round on top,

instead of flat. Both squares, winding as well as center staff, must be of the same size; at any rate differing so little that they can be wound with one key. •

8. It happens occasionally that the end of the center staff presses against the closed glass, whereby the center wheel loses its due quantity of shake. Indeed this pressure, with thick glasses, is sometimes so strong that the centerstaff is pressed back and protrudes thus beyond the dust cap. The centerstaff square, consequently, is not to be shortened until it has definitely been found out that this defect be not present. Next examine, by opening and closing the dust cap, whether the squares can pinch in their holes. (This must also be attended to after the adjustment, whenever it became necessary to alter the centerwheel bridge or the barrel.) Should the winding square holes in the dust cap be so small (which frequently occurs) that a fitting key is only found with difficulty, and that the repairer finally does not know whether the key simply pinches or does not fit, it is advisable to open them by filing, in case they do not stand in the middle, or else by chamfering, and removing the burr created.

CHAPTER II.

EXAMINING THE MOVEMENT.

9. Until now, we have simply investigated the exterior of the watch, and we now turn our attention to the movement.

The fruit cannot always be recognized by its shell; this latter is often handsome and attractive, while the kernel is bitter and ruined; this is also the case with watches.

Many a manufacturer only works for the purpose of pleasing the eye of the purchaser, while the work is full of palpable errors. Our first task is to examine the movement in the case, and to discover defects no longer visible after the movement has been taken out of the case.

10. Let us commence with the balance. It occurs often that the banking pin, or even the balance itself, rubs on the central part of the case or on the joint of the dust cap. This defect can be corrected, according to circumstances, by either scratching a little out from the case, or simply shortening the banking pin by a trifle, or else lowering the balance.

11. Another defect is that the dust cap presses upon the upper covering plate of the cylinder bridge, or upon the unduly far protruding screw ends, perhaps also upon the upward protruding bouchon of the stud. This error is best detected by putting a little red at these places, and corrected by removing the protruding screw ends, shortening the protruding bouchon, or lowering the bridge.

More seldom, and only in the case of very flat watches, we have left the sole remedy that the dust cap must be turned out.

12. An unduly high screw head of the cylinder wheel bridge, which may cause tensions at the joint of the dust cap, as well as pinching of the scape wheel, is to be shortened to its necessary height.

It is very often found in low-grade watches that the bridges stand too near to the inner case rim, equally causing disturbances in the movement, by pressing the wheels to one side, squeezings, etc. We seldom have another remedy in this case than to file or turn sufficiently away from the offending places of the case. These corrections, however, have to be applied with care, not to injure the appearance of the watch.

13. The rubbing of the barrel at the central part of the case is a common defect, to be remedied in most cases by scraping away the case; still, it may happen that it cannot be corrected in any other manner than by slightly beveling the barrel teeth from above. These are the most frequently occurring defects, found more or less with every adjustment. As already stated, other ones must be improved according to circumstances, and definite rules can barely be established in the premises.

14. After having examined whether the movement sits firm in the case, the case screw is loosened, and the movement taken out. Great stress is to be laid upon the secure fastening of the movement; the case screw must draw well, and be replaced by a good one in

case it should be bad. If the case rim, over which the screw head is turned, is too thick, the defect is corrected by beveling the under side of the head a little, or (which occurs frequently with German silver cases with thick rims) by making the rim a little thinner. Should the movement shake in the case, or be too small for it, then, in the former instance, long pins are inserted in the outer plate rim on the side opposite to the screw, and these pins must be closer to the dial than the former ones. If, however, the circumference of the plate is too small, no other remedy remains than to drill very little protruding thick pins in regular intervals around the plate.

The inserting and taking out of the movement out of the case must be done without the employment of force, and the movement, after turning the case screw by half a turn, must no longer be loose.

These jobs are to be made before cleaning the watch, since drilling and filing chips can fall easily into the movement.

15. The opening above in the center-piece of the case, there where the pendant head is soldered on, must be closed by a pin, since it would operate like a funnel, and admit dirt into the movement. Next attend to the closing, as has already been explained at article 5; after which lay the case aside.

16. The author of this essay worked for some time for an employer who was a very eccentric and skillful watchmaker. After the movement had been taken out of the case in his shop, the repairs commenced at the hands. (According to correct principles, an examination of the movement cannot be commenced until the centerwheel has been righted.) In case that the centerstaff could remain at its actual length, the next examination was directed to whether the minute hand sat firmly; if this was not the case, the cause was ascertained whether, perhaps, the pivot for the minute hand by its shortness was too tapering, or the reverse, thicker in front than behind, and any occurring fault corrected at once. Labor only ceased when the minute hand could be pressed firmly on; it sits firmer in this manner than many a one driven on with the hammer, the hole of which is full of burr, etc.

The hour hand was, by dressing the cannon pinion or by bending it, set in such a manner that it passed in the center of the space of seconds and minute hands. The cannon pinion had to have sufficient shake under the minute hand and dial. The seconds hand was set thus that it also passed free upon the dial, according to the height of the minute work. Experimental turning of the hands is indispensable hereby. Scrutiny was at the same time directed toward whether the seconds hand rose or fell, and the repairers, when treating the fourth wheel afterward, had sufficient data.

17. When this was regulated, the holes in the dial were examined. As previously remarked, indiscriminate work must not at once be commenced, but, if standing obliquely, the dial was first sought to be straightened, since by a slight correction in this particular no improving of the holes is subsequently necessary.

18. The straightening of the dial is sought to be obtained by an appropriate bending of the feet; it becomes necessary quite often to assist by improving the holes in the plate.

If none of these remedies is sufficiently thorough, then only one and the last help remains: the objectionable foot, preventing the sitting straight of the dial, is to be removed, the place must be cleansed of enamel by means of emery, and another foot, cut from an old dial, and to which a little of the copper underlay is to be left, is soldered with easily flowing solder at the appropriate place.

This defect is happily of a rare occurrence, and not advisable in the case of a dial showing fine cracks, since these will turn black by heat. The dial must be placed into the case repeatedly to be satisfied that it fits.

19. The dial must be of such a construction that it can quickly be taken off and fastened in place again. But this much desirable requisite is with many watches rather the exception than the rule, and tools have first to be employed for straightening the feet, which have been bent over the plate, before the dial can be taken off. If by an adjustment the dial plate screws are so small that they do not

seize the pillars, and there is sufficient space to take larger ones, it is indispensably necessary to employ the latter remedy. Also pillars are not infrequently found, the cuts of which for the screw-head are located too broad and too high above the plate. These cuts are easily filled out with tin, and a suitable cut is made in them by turning round the dial-plate screw. Nor is it of a rare occurrence that nothing can be done with screws, and in this case tapering, well-filled pins are used best.

20. The dial plate having been disposed of in its correct place and fastened, the repairer is then enabled to see whether the holes in the dial for the canon pinions are of correct size to prevent rubbing. To prevent the cracking of the enamel when enlarging these holes, it is necessary to cause the file to operate toward the interior; a little oil of turpentine may also be added. The danger of disfiguring the dial with ugly scratches by an accidental slipping of the file is obviated by rounding the point of the file with an oil-stone, polishing it a little subsequently. The beauty of the holes is enhanced by finishing with an emery chamferer, whereby the sharp corners are reduced.

Having finished the hands and dial, this latter is laid aside, and the work under the dial is inspected.

21. Although my view and that of my previously mentioned employer coincide, still, I cannot admit it to be advisable to set the hands in order at this early stage. Supposing it were done, but it is advisable afterward, and necessity compels, in the progress of the work, to place the lower center wheel hole in the plate by means of a bouchon out of the center, then all work has been expended in vain, and we might begin anew to regulate the depthings of the minute work. It is best, therefore, to confine the preliminary work to ascertaining actual defects, and to correct them in due time when setting the minute work in order, at which time such corrections are made far handsomer and nicer.

22. But it is necessary to find out whether screw ends or minute wheel pin and the female stop protrude, by which a fracture of the dial can easily be caused. If the lower cylinder bridge stands above the level of the plate, the necessary shake of the cylinder is contracted subsequently by screwing on the dial.

It is found in many watches that the barrel stands too high under the dial. The female stop screw is to be made as low as possible, but not every time the different parts of the stop work itself, etc. To meet these injurious frictions and pinchings, the enamel on the lower side of the dial, where it presses, is ground off a little with a heavy emery wheel.

CHAPTER III.

TAKING DOWN THE MOVEMENT.

23. I often had the opportunity to observe watchmakers, and especially my younger colleagues, that they took down the movement, without first inspecting it with all parts in place, for the purpose of discovering the defect causing the standing of the watch, which, it is very evident, is necessary for the success of a repair. Work is much facilitated thereby.

If the watch stops obstinately, ascertain first, without letting down the movement, or causing the balance to vibrate, which is the offending part, whether it is owing to the escapement, train, barrel, stop-work, etc., by carefully examining, with tweezers and magnifyer, where the power ceases.

24. When the defect causing the stoppage of the watch has been found, begin, so as to work to advantage in the future, to examine the movement when taking it down, and to pay attention to the following: Whether the cylinder has sufficient end shake, whether its upper or lower cap or cap jewels lie firmly, and from what side shake is subsequently to be increased or contracted; whether the cylinder notch for the escape wheel, and therewith the motion, is free. Also, whether the balance runs true round and stands straight, and if this latter is not the case, toward what side it must be straightened. Lead the balance slowly round, and observe whether it scrapes upon the plate, upon the accidentally protruding end of the minute wheel pin, or upon the scape wheel bridge; whether the

balance arms may touch at the hair spring closing, or on the hair spring stud; furthermore, whether the balance moves at a sufficient distance from the center wheel and plate, and toward which side it must be brought; whether the banking pin can scrape on the pinion or arbor of the fourth wheel, or whether it locates against the stud itself, in place of merely striking against it as limit. Where is the hair spring located? Is it in general suited to the watch; is it not too strong—to be seen or counted by the vibrations? Does it lie free and flat to the balance and scape bridge? Is it too large; that it may strike against the center wheel or balancespring stud? Does it lie funnel shaped, so that it is to be located higher or lower on the collet or stud, in order to have it flat? Do the screw heads protrude on which the collet might scrape?

In the case of high watches, there is less need for this careful scrutiny, and a single glance frequently suffices to observe them.

(To be Continued.)

Table Utensils.

[BY JOHN W. MILES.]

Continued from page 182.

THE DATE of spoons, like that of knives, is unknown. They are mentioned in the biblical account of furniture in the Tabernacle and Temple, and were undoubtedly known to the early Egyptians, who made them of wood, bone, ivory or bronze, ornamented with animal or human figures or with the lotus flower. They are certainly as old as soup, and were probably used from the earliest times to dip up the liquid portions of the food. Without positive information upon the subject it may well be supposed that the first spoons were of wood; that substance being easily worked into shape, and harder materials not being absolutely necessary for the purposes for which spoons were used. We can the more readily believe this since wood was employed for many other uses less credible. For instance, Pliny says that "table books of wood were in use before the time of Homer," and Plutarch informs us that the laws of Solon were inscribed on tables of wood. A wooden spoon from the Fiji Islands, figure 11, is a good specimen of this primitive work as applied to table utensils.



FIG. 11.

It appears to have been cut from a solid block, and, though crudely finished, great care was probably bestowed upon its construction. In pleasing contrast are the two wooden spoons for eating cream, from Calcutta, illustrated in figures 12 and 13.



FIG. 12.



FIG. 13.

These latter are certainly not only beautiful pieces of carved work but the taste evinced in their shapes and general proportions are worthy of the present day. The skill that provides the ornamentation without decreasing the strength is remarkable, and the device for supporting the bowl in figure 13 betrays an appreciation of unity in design scarcely to be expected. In the illustration of a bronze spoon employed by the Greeks before the age of Homer, figure 14, it would seem, from the strong resemblance, that they used the fish as

a prototype for other things as well as for ships. In the decoration of the bowl we find, also, an exhibition of that taste for art which

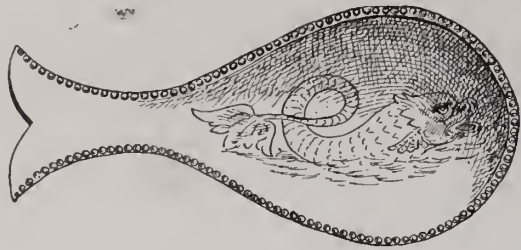

FIG. 14.

was for ages a characteristic of the Greek race. Bronze was extensively used by the early Greeks in the manufacture of their weapons and tools, and, for the several uses of their ceremonious sacrifices, knives of peculiar shapes were made of this metal, figure 15. These

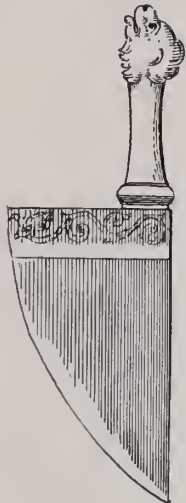

FIG. 15.

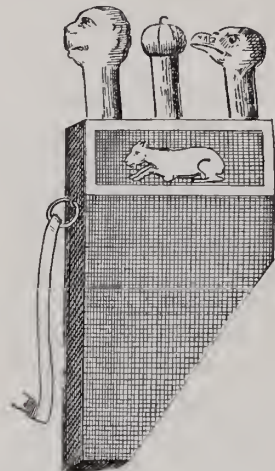

FIG. 16.

sacrificial knives or *dolabra* had sometimes one and sometimes two handles, and were kept in cases to preserve the edge, figure 16. Those in use by the Romans at a much later date were of the same shapes and general appearance.

That knives were very much used at table by the early Greeks is doubtful. For a long time previous to the Homeric age they lived solely upon the products of the soil, for it was considered a sin to kill for food animals that did no harm. Later on the threatened extirpation of corn and fruit caused the Delphic oracle to order that meat should be eaten. It became, therefore, an article of food, and was served in dishes of wood, or, for the better class, of bronze. Earthen vessels were also used, though with considerable aversion—a sentiment derided by Plutarch. With the inauguration of a meat diet the knife, as an aid in eating, assumed greater importance, although it does not appear that every one at the table either had or needed one. The meat was boiled and thus served was eaten with the fingers, a custom of both earlier and later times. When the meat was cooked by roasting, before being served it was carved into small pieces that could be carried to the mouth with the hand. This work of carving devolved upon the slaves, who were expressly taught by a professor of the art. The same servant, however, did not carve every joint or animal, but only such as he had been taught to cut, and musical instruments were sounded during the operation. When the fingers of those eating became soiled or greasy they were cleansed with pieces of soft bread, which were then given to the dogs, who appear to have dined with their masters. The hands were washed both before and after a meal, being scoured and perfumed in the last operation. Children were taught to take their meat in their right hand and their bread in the left, which would preclude the use of any utensil.

Iron was little used by the ancients owing to the difficulty of reducing it from the ore. It was not introduced into Greece until B. C. 500, although known as early as Tubal Cain, and the Romans did not

begin to use it until after the second Punic war. Even the Egyptians, surrounded with an abundance of the ore, knew nothing regarding the use of iron. Up to the time of the Roman invasion of Britain this metal was used by the Britons as money, and many remains have been found in England where the ore was reduced by the conquerors evidently by the crudest methods. Bronze was used by the Celtic population of Britain in the construction of all instruments requiring hardness and tenacity, such as swords, arrow heads, etc. Many of these have been found in the barrows and Druidical remains of that country, and among them knives or daggers with blades of bronze riveted to handles of wood, bone and ivory. In a barrow at Normanton in Wiltshire one of these handles was found decorated with zig-zag and parallel lines formed by numerous pins of gold driven into the wood. Lines of this character appears to have been a very popular style of ornamentation among them, especially upon pottery. The knives probably served the double purpose of fighting and eating, for though one portion of the Celtic nation cultivated peace and abhorred war the others were not so scrupulous, and, being habitually inured to arms, were constantly encroaching upon the rights of their unresisting brethren. After the Roman invasion we find a great number of bronze knife blades having originally handles of wood, although some have been found with bone handles still intact. Some of these knives were evidently intended to hang from the girdle, a loop or ring protruding through the handle for that purpose, figure 17. The handles were also often made of bronze highly ornamented.



FIG. 17.

Spoons of different shapes and sizes are also found, with bowls (for eating eggs) more nearly circular than oval, and often with pointed ends for picking snails or periwinkles from the shell, figure 18. A



FIG. 18.

spoon similar in form to these Roman *cochleare* is in use at the present day, with a point for eating crabs and with an elongated shovel-shaped bowl for marrow. Some few spoons of silver of supposed Roman origin have also been found in Britain, but two found at Pompeii belonging to the same or nearly the same period are undoubtedly authentic. These, although peculiar, are symmetrical, and not greatly dissimilar from the modern styles, figures 19 and 20.



FIG. 19.



FIG. 20.

The bowls have a rib and end in a point, while the handles are finished, one with a ball and one with the semblance of a goat's foot.

The Romans reclined upon couches while dining, and used neither knife nor fork. The spoon also was limited to the *cochleare*, which was of silver, and, as we have seen, was only employed for special food. The knife certainly appeared at the table, but only in the hand of the *scissor* or carver, who cut up the different meats with profound solemnity and in perfect musical time.

A bronze knife found in a grave at Selyen and believed to belong

to a period immediately preceding the fall of the Roman empire, is a type of the primitive Anglo-Saxon knife, figure 21. The handle has



FIG. 21.

been beautifully enameled, while the blade does not greatly differ from our modern shapes. An Anglo-Saxon blade of iron inlaid with bronze, figure 22, also exhibits a form with which we are not unfa-



FIG. 22.

miliar, while a still later Anglo-Norman knife, figure 23, shows two notches in the point, but for what special purpose we are unable to

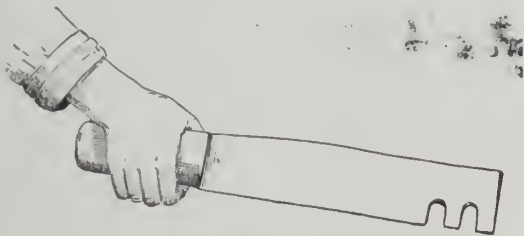

FIG. 23.

determine. It does not appear that the Anglo-Saxons were much given to the elegancies of life, although they had their code of manners. They were a rough people, occupied principally in eating, drinking and fighting, the latter diversion occurring frequently in their dining halls and while at table. It was a common practice as late certainly as the 15th century for the people to carry their own knives in a sheath attached to the girdle. Knives formed part of the accoutrements of a bride, and were, with other things, suspended from the belt. Chaucer's "Miller of Trumpington" wore a Sheffield knife.

"A shefeld thwitel bare he in his hose,"

and all the portraits of Chaucer have a knife hanging at his breast.

In the English "*Stans puer ad Meusam*" or table etiquette the guest is instructed to "bring no knyves unskoured to the table," which means that he must keep clean the knife that he carries with him. As an example of the table manners of that period and the faults requiring correction I give a few of the most peculiar rules from the authority above mentioned:

"Never spit over the table or upon it."

"Let thy nails be clean, lest perchance they offend thy neighbors."

"Scrape not nor scratch your own skin with your fingers; always avoid wiping your nose with a clean hand (handkerchiefs were unknown at this time), and at table avoid picking your teeth with your knife."

"Be careful at table not to handle the cat or dog."

Although we owe to the Middle Ages the greatest improvements in table utensils, or at least the most complete records of them, the rule is naturally followed that the various customs and the various implements acquired by each nation coincide with the different degrees of civilization attained by them. It is, therefore, from the southern and more advanced nations of Italy and France that our most artistic specimens are derived.

Up to the 8th century the Gauls fed upon herbs, fruits and acorns. From the 8th to the 12th century they consumed large quantities of meat, principally pork. All meats were boiled, soup being made of the water and served at least twice a day. Butter, known and eaten from earliest times, was included in their repasts. Cheese also formed a portion of their diet, and we learn that the emperor, in the 9th century, being once served with green cheese (which variety was before

unknown to him), he removed the green part with his knife, thinking it to be bad. They also ate bread which was cooked under embers. In the absence of leaven the loaves were made thin and employed as plates for cutting up the other food upon, and, when saturated with sauce or gravy, they were eaten as cakes. It was not until the end of the 16th century that the bakers of Paris began to use yeast in their bread. That knives formed a part of the table furniture at this time is more than probable; knives certainly were used for carving such portions of the meat as were not separated in cooking, figure 24, but the blades and handles of these do not differ much from those of the modern kitchen. At one period the loaves of bread were made round



FIG. 24.

and were served cut in slices. These slices were piled by the side of the carver or *Ecuyer Trauchaut* (cutting squire), who had a pointed carving knife and a skewer of bone, silver or gold, which he stuck into the joint. Having cut off a slice of the meat he took it on the point of the knife and laid it on a slice of the bread, which was then served to the guest. Previous to the adoption of the skewer the carver held the meat with his fingers while cutting. This is in accordance with an ancient English "Boke of Kervying," wherein the carver is told "Set never on fyshe, flesche, beest ne fowle more than two fyngers and a thombe." The knife in figure 25, from an illumination



FIG. 25.

of the 13th century, is represented in the original as being held in the hand of a Baron seated at table with two companions. The latter had no knives, and possibly in small parties one knife answered for all. Other knives were in use, and some of very unique shapes, as the one illustrated in figure 26. This had a blade of steel with a fan-

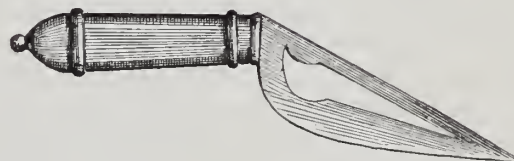

FIG. 26.

ciful opening in the center, while the handle, running out at a curious angle, would seem to indicate some peculiar use. In these two last illustrations the handles were of wood or ivory. They belonged to the nobility, and were, consequently, the best in use at that time. Posidonius assures us that these articles were not all of the simple character of figure 25, but that the blades were often made to slide into the handle by means of a spring, possibly like our ordinary pocket knife. These objects demonstrate the fact that in the 13th century certain knives were made exclusively for table use. Previous to that time these implements answered for every purpose, and, though used in eating, as we have seen, were also used in battle and in the field. We are at last, therefore, enabled to treat them as a distinctive article of table furniture.

(To be Continued.)

The Art of Goldsmithing in Spain in Antiquity and the Mediæval Age.

WHILE Spanish architecture and painting have long ago been allotted a high rank in art history, the purely decorative arts of the Iberian peninsula are comparatively little known. It is a singular country this, the enchanting empire of the south, which,

still more so than even the semi-barbaric countries of the Orient, sullenly seeks to withdraw itself from the benign and sobering influences of our civilization. It would almost appear as if the last remnants of all obsolete and once venerated traditions of the mediæval ages had sought an asylum in this south-eastern corner of the Old Continent, and barricaded themselves against the leveling influences of these democratic times. At the north we find as grim sentinels the high, snow-covered, haughty mountain ridge of the Pyrenees, while at the west, south and east, the sea, with its ceaseless din, separates Spain from the rest of the vulgar world. While beyond the waves of the sea, to the south, the crescent of the Islam is the hallowed representation of piety to the believing Mussulman, the eye of the pious Catholic reverentially turns toward the Orient, to discern the Promised Land, and the mysterious Thule dawns in the far west. Wonderful mixture of fabulous phantasy, Oriental splendor and fanatical piety. The political vagaries of unhappy Spain, even, are proof positive that the old traditions of ages long by-gone, of a state of affairs that disappeared centuries ago, are still retained there in full vigor. French fashions, European constitutionalism, British business energy, American invention and go-aheadism, all pass by unnoticed, and have not yet succeeded in conquering the mediæval age. The opera bouffe, the Götterdämmerung have not yet ousted the national bull fights. Spain still broods over its glorious and resplendent past, until the culture of its northern neighbors, like the undermining wave of the sea that laves its shore, shall finally burrow under this world apart, wash it together, and from the débris will arise the New Iberia.

The Pyrenean peninsula was at all times famed for its wealth of metals. Both Greeks and Romans vied with each other in singing the laud of its subterranean treasures. Strabo, the Greek geographer, says that no country in the world possessed gold, silver, copper and iron in such prodigious quantities and of such purity. Solid gold nuggets, of the weight of a half a pound, were at times found in its rivers. And it is no wonder, therefore, that the art of goldsmithing soon flourished in high perfection, and very eminent specimens of the art are often found.

The Visigoths, even, who overran Spain with their host in the fifth century, and settled in the southern provinces of Iberia, and who prided themselves on their frugal and simple customs in dress and ornament, here devoted themselves with predilection to the noble art of goldsmithing, and understood to value its productions. Chormund and Ewarich, Amalarich and other kings of the Goths, promoted it, as far as lay in their power, according to the historians, and collected a large quantity of the best specimens for their art treasures, especially crowns, diadems, miters (caps for ceremonies), necklaces, bracelets and other ornaments, all of which were frequently set with jewels. St. Isidor, of Seville, speaks of the splendor of the drinking vessels of the Visigoths, and praises their weight and metallic luster, and especially the skill of the goldsmiths, (*manus artificis*, "the hand of the maker").

A part of these treasures is still in existence and may be found scattered through the museums (Louvre and Cluny, in Paris, Almeria Real and Musco Arqueológico, in Madrid), otherwise the reader would be tempted to credit these and other glowing eulogies to the account of the inventions of a fertile brain. A Moorish author reports that the horse of Rodrigo carried a saddle of gold in the battle of Guadaleta. The Royal Armory of Madrid possesses the reins of a horse's harness richly incrustated with silver and said to have belonged to the second last king of the Visigoths, Witiza.

When the Moors, so well accustomed to splendor and luxury, conquered Spain, they were astonished at the amount of gold and silver treasures of the Visigoths. Especially the conquest of Toledo in 712, according to the chronicles of the Moor, Al Makkari, yielded such a quantity of products of the goldsmith's art that it beggared description, both on account of quantity of articles as well as richness of metal, together with artistic execution.

The Moors were still more addicted to the art of goldsmithing

than the frugal Visigoths. Luxury, display of color, luster and beauty of form have at all times exerted a great power over the peoples of the Orient, and Spain owes a large part of its originality to Moorish art, and to its Arabian blood many a peculiarity of its character. When we read the Moorish accounts of the art creations of Spain we might imagine ourselves transported into the domain of Aladdin's Wonderful Lamp. If it is said that one of the doors of the mosques of Cordoba was of pure gold, or that the palace of the Bailiff of Cordoba was covered with gold and silver tiles, and many others of these fabulous accounts, we are dealing with exaggerations and may well consign them to the limbo of the incredible. Happily, we have the credible testimony of specimens of Moorish and Spanish art, and from them we may well establish our premises for reasoning. The chief seats of Moorish art and skill were Cordoba, Murcia, Sevilla and a few other cities of the peninsula; Murcia was famous for its iron coats of mail, encrusted with gold and its works of saddlery, adorned with gold; its productions were exported to all parts of Africa and the Orient. Sevilla's fame was based upon its arms, inlaid with gold and silver, and jewels.

Everyone knows that the art of damascening metals is of Oriental origin, as is even sufficiently indicated by the name. Monk Theophilus extols the skill of the Moors in this branch, and it is therefore very natural that the damasceners of Murcia, Cordoba, etc. followed those of Damascus, Bagdad, Aleppo, and Mossul. The Spanish language to-day still uses the Moorish word for damascening, *ataujia* or *taujia* (Ital., *tausia*, French, *tauchie*). It may be supposed with the same probability that the Moors introduced the niello in Spain, at least, it is not seen in any Spanish work antedating the conquest of the country by the Moors, while several articles of such work of Hispano-Moorish origin have descended to us. We call to mind an ivory fount with silver niello, of Moorish origin, contained in the cathedral of Narbonne and dating back to the tenth century, and a similar one in the dome of Gerona, described by Ricardo de Madrazo.

The Moorish art of goldsmithing stood in Spain in high preference even with the christians, and in spite of wars and religious fanaticism these articles produced a lively exchange between the Christian and Mohammedan provinces. It is a singular fact that nearly all the technical expressions of the goldsmith's workshop are of Arabian and not of Latin origin.

Both the Spanish and Moorish women were very fond of adorning themselves with gold trinkets, and it assumed such proportions that, a contemporary says, they had gone stark mad on the subject of personal adornment. Their love of luxury was excusable, however, since the men carried the value of large countries in their sword hilts. The chief productions of Moorish goldsmithing were ear-rings, necklaces, bracelets, rings and amulets; we treasure many of them in art collections, and they speak of an artistic workmanship. The custom of wearing an amulet as a talisman upon the breast, which was customary even with christians of the mediæval age, is still today a characteristic of the Moorish ladies of Northern Africa. These amulets were generally highly ornamented and of a wonderful excellence of execution. We saw one of these talismans of Moro-Spanish origin, of enameled silver, ornamented with arabesques and Moorish writing of an extremely delicate workmanship and skillfully soldered. How general the wearing of them had become, is seen by an edict of Charles V., of 1525, who tried to forbid them.

The Moors of Spain led the taste and luxury so decidedly that the christian land owners rose against it in the 15th century. Isabella, the catholic, forbade the former from wearing gold or silver upon their persons. After the conquest of Granada, they were despoiled of their treasures, and when the Moriscoes, who had secretly adhered to the customs, morals and tenets of their fathers, also persisted in following their inclination for luxury and display of precious ornaments, the sumptuary laws became more stringent. This, however, did not hinder the Moorish taste from being the prevailing one in Spain, and it could not be eradicated, especially from among the lower people. Even to-day, the Castilian lady wears

long and heavy *arracadas* (ear-rings), ornamented with emeralds, pointing unmistakably to an Arabian origin, while the goldsmiths of Cordoba and Malaga work the filigree according to Moorish pattern.

But not alone in that part of Spain subjected to Moorish rule, flourished the art of the *plateria*, as it is called by the Spaniards; also in the independent part of the peninsula skillful masters worked and manufactured according to their own conceptions, and thus we encounter apart from the Visigothic and Moorish taste in mediæval Spain an actual Spanish one, which, of course, is influenced more or less by the two former. Among the curiosities we may especially mention the silver and gilt armchair of Martin I., of Arragon, the so-called "Silla del rey Don Martin," and preserved since the memory of man in the dome of Barcelona. This chair, which, it is said, was used by Martin I. (1395 to 1412), is constructed with a remarkable skill and delicacy, in the style of the 14th century. The lower part consists of small columns resting upon a base-plate, which converge in a trifol arch, above which perforated rosettes spread out and form the seat. The back and arm rests are formed in a similar manner. It is a pity that the name of the master of this highly artistic work has not descended to us.

After the mediæval art of Spanish goldsmithing had produced many excellent works, it took a new departure at the time of the Renaissance.

Long after Italy and France had forsaken the Gothic style, the trifol pointed arch and its rosettes was still adhered to in non-Moorish Spain, while the Moorish part retained the forms and methods of its former rulers, and both styles commingled, each one the renaissance of the art upon the Iberian peninsula. This renaissance is less characterized by a rejuvenation and return of style to ancient Greek forms, such as took place in Italy and France than by the increasing influence of the Moorish element, the artistic forms of which became the generally governing ones, in spite of all religious and national hatred; we do not wish to say that the old traditions were blindly adhered to, many other influences operated to shape the present style. Italian style exerted the greatest influence, especially at the places where Italian masters could congregate, for instance, Barcelona. We find works of this town, which are most internally related to the nielloed productions of Italian art of the 16th century. The employment of enamel for gold ornaments was perfected at an early date. The Spaniards soon adopted and perfected the art branches of the Moors, for instance, damascening and filigree, and the productions of the late Spanish master is in nothing inferior to the choicest specimens of the Moors. And why should it be otherwise in the country of Calderon and Murillo, Cervantes, and the proud splendor-loving Caballero?

Problems in the Detached Lever Escapement.

BY DETENT.

NO ESCAPEMENT invented up to the present time has as many advantages for a pocket watch as some of the detached lever escapements. In fact, it is the only dead beat escapement which it is not possible to set in the pocket. The so-called chronometer, the duplex, the cylinder, escapements, all have points in the arc of vibration, which, if the balance is deprived of all momentum at these points, set, as it is termed, and no power of the train will put the balance again in motion. Nothing but an outside impulse will unlock the escapement and set up the action. The detached lever, however, if well made, will unlock itself and re-establish the complete action of the escapement and train, and still it is a completed dead beat escapement, and the balance completely emancipated from the train during almost the entire arc of vibration. As indicated by the title of these articles, the writer desires to thoroughly arrive at the principles involved, not only in such styles as are now made, but to dig down, so to speak, to the bottom or foundation of

the principles involved. The parts comprised in a lever escapement are: a scape wheel acting on pallets (or some equivalent device), tending to produce an alternating motion in a bar or lever, said lever acting through suitable mechanical arrangements (fork roller and jewel pin), producing in conjunction with the pendulum spring a continuous vibratory motion of the balance. These parts in some form must be involved in the lever escapement. There are almost endless ways in which the combination can be made; but the great question is, does the combination in question offer the greatest number of advantages? All this will be considered as we go along. Undoubtedly the simplest form of lever escapement consists of a zig-zag groove or channel cut in the side of a flat wheel as shown in fig 1, while into this groove goes a pin, *e*, rigidly fixed into a lever,

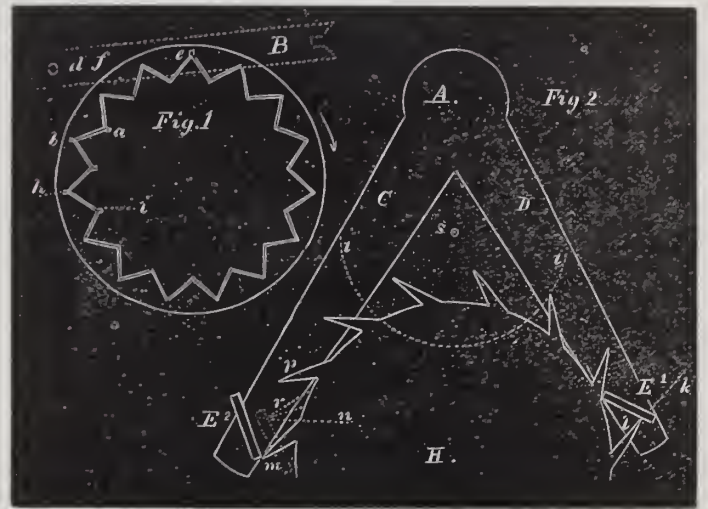

f, moving on its axis at *d*. If this groove has places of repose as shown at *b c*, it becomes with the proper fork and roller a dead beat escapement, with theoretically very little loss of power, but practically there are many things to be said against it. The writer's object in showing it here is to give an idea of the variety of forms which the lever escapement is capable of assuming, besides it capitally illustrates the principle of impulse and lock. As the inclined faces of the channel acting against the pin *e* shows vividly how the pin is alternately *wedged* in opposite directions, and the pin *e* falling on the repose planes at the notches *b* and *c*, illustrates the principle of locking, as the straight face of these notches are on the lines *i* and *u*, creating a "draw" or tendency to hold the pin in the notch. This form of lever escapement has another novel feature about it, and this is the center of motion of the lever can remain at *d* and the fork action at the dotted lines *B*. In considering the usual forms of lever escapements we will assume in this article we are dealing with the ratchet tooth, or, as it is more generally termed, the English pointed tooth scape wheel; but we will subsequently take up the club tooth scape wheel. In the first view of the ratchet tooth escapement we will conceive a ratchet tooth scape wheel of 15 teeth, and pallet arms embracing $7\frac{1}{2}$ teeth or just one-half of the whole number, and consider the conditions involved. The pallets, as shown at *E*¹, *E*², are simply impulse without locking faces; or, as we find them in clocks, purely recoiling beat; so called because as a tooth falls or drops from one pallet another tooth strikes the impulse face of the other pallet, and any continued motion of the pallet just releasing the tooth will cause a retrograde motion of the scape wheel from the action of the pallet now engaged. This form of pallet and pallet arms will also explain the difficulties encountered in such an extended arc of pallet action, in the way of locking faces. The pallet *E*¹ would require to have a locking angle quite as great as the tooth, as shown at the dotted line *k*, fig. 1, to ensure safety; while the locking angle on the pallet, *E*² as indicated by the dotted line *u*, would be so unlike anything in our experience as to appear incorrect at first sight. Still on inspection it will be seen to be quite correct, as the dotted outline of the pallet *E*² is indicated at *m*; this shows the position of the pallet *E*² after one impulse. The tooth

p will have passed to the position indicated at the dotted outline tooth at r . The center of the pallet staff is at A , and it will be seen that angle of pallet action is very short, and could only be increased by lengthening the teeth, and then but in a limited degree. The disadvantages of employing such a pallet action is too apparent to need further attention, still it is worthy of careful study, assuming a smaller and smaller number of teeth taken into the pallet action until we get down to the number now almost universally used of $2\frac{1}{2}$ teeth as indicated by the dotted curve tt , with the pallet center at s . This system of pallets enclose an arc of 60 degrees, and is consequently just the radius of the scape wheel; hence a circle of say 10 inches in diameter, swept with compass set at 5 inches, will be used in all our drawings; the cuts in this journal will, as a rule, be $\frac{1}{4}$ this size. At one of our largest watch factories one of the workmen made a model of hard wood, with all the working parts complete, of a lever escapement; and I venture to say that the study of this model done more towards impressing the minds of those who studied its action than all other sources of information on this subject combined. And I would earnestly recommend all the young readers of this article to make such a model, with some improvements and changes as were suggested by the skillful workman who examined it. These changes would be to have two scape wheels, ratchet and club tooth, with pallets to match; also pallets which were known to be incorrect; and in the fork and roller action have the lower so constructed that a disproportionate size of roller can be used. This last condition can readily be obtained by having the ruby (or rather its substitute) movable, and the fork so constructed that it can be extended. The writer will give in the next paper in this series complete instructions for drawing a ratchet tooth escapement, and at the same time detailed directions for such a working model. It is not imperative to make it of wood; it would be nicer of brass, and for that purpose a scape wheel 5 inches in diameter would be ample. The great benefit to be derived from this source is having a working model so large that it can be studied without an eye-glass. And moreover the motions are so slow that the eye has time to detect and analyze every action. The student can set his pallets so one is correct the other faulty; start his escapement going and see how it is affected. The whole affair is run with a little weight and when wound up will run for 5 or 6 minutes. In solving such problems as we propose to introduce in these papers a model like this beats all the drawings and reasonings of a whole board of mechanical engineers.

The Royal Silverware of France.

THE SILVERWARE of the king occupied an important place among the artistic productions and possessions of the old French kingdom. Louis XIV. ordered, during the years 1666 to 1680, from the Paris silversmiths, no less than 2,039,697 livres silverware; in the year 1668 alone, the royal court received for 500,000 livres, and in 1670, for 546,393 livres silverware, although, in 1666, the royal treasury had received for 180,000 livres, and in 1667, for 260,000 livres. But from 1689 onward, therefore exactly one century before the Revolution, the royal constellation began to pale. The difficulties of the king increased from year to year; the state debts grew in accordance with the decrease of the revenues. From 1690 forward, the king was frequently compelled to send silverware from the royal treasury for melting to the mint; and since the high nobility had faithfully copied him in his ostentatious display, they, too, were forced to sell their gold and silver vessels from time to time, impelled by pressing wants, at which the celebrated letter writer, Madame de Sevigne, expresses herself in the most doleful complaints. For another short time the star of fortune fitfully burst again through the clouds that obscured the sky of the "sun king," and his old love of luxury for lavish display of silverware in his palace and upon his tables re-awoke. But this turn lasted only for a

few years, because already in 1709, Louis XIV. was forced again to send almost all his silver to the mint for coinage. The royal gold and silver treasury was at this time so thoroughly depleted (1709-10), that Maréchal de Bouffleurs and Duc de Grammont had to loan their gold and silver table services for the royal table. Pontchartrain and Desmarests made all endeavors to save the last remnants of the treasury, but in vain. Saint Simon gives vent to just complaints: "The damage and loss occasioned by the destruction of all these admirable works of art, castings, chasings, and engravings, all these reliefs and ornaments, with which the silver vessels of the wealthy and nobility are adorned so luxuriantly, is incalculable, and can never be expressed in sums of money."

Lathes and Lathe Work.

BY THE MODEL WATCHMAKER.

IT IS NOT an uncommon job to have to put in a duplex staff; these, in large cities can be obtained of the material dealers; but in small towns to know how to make one expeditiously is an accomplishment not to be despised. The best course to pursue (according to the writer's experience), is to select a piece of Stubs' steel wire a trifle larger than the largest part of your staff, and with one of your split chucks (if you use an American lathe; if not, one of those described in former article for holding wire), turn the wire down to the size indicated at a , fig. 1; this is the size of the staff at which

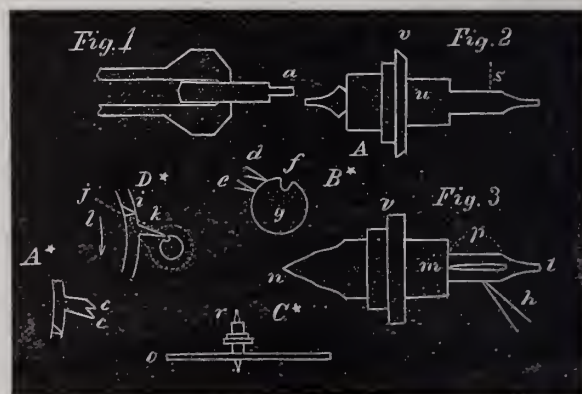

the scape wheel teeth touch it. This should be turned to the exact size of the old one; or in case the old one should be lost, the size can be pretty nearly determined by the teeth working against the staff; that is if it should be of the double acting duplex pattern generally termed a triplex. Such an escapement can be defined by saying that there are two actions on the staff for each impulse imparted to the balance. If the staff is for a watch of this kind it should have a diameter of about $\frac{3}{4}$ the space between the teeth cc , diagram A^* . If the watch is of the true duplex type, the judgment must be exercised, and the staff turned of such a size as will hold the resting tooth secure. At diagram B^* is shown the action of the tooth; d shows a tooth in about the right position; while e shows a tooth which, in action, will produce bad results, either slipping by, or causing too much friction by crowding. This condition can exist from two causes: the roller being too small, or the teeth on the scape wheel too short. Generally watches of this type (single action duplex), have a jewel on the staff; if this is the case, still the same discrimination must be observed, and if the condition shown at e exists, the staff should be set nearer the scape wheel. To do this expeditiously is very much like many other mechanical operations in watch work—the first great feature being in knowing exactly what to do; and the second exactly how to do it. To stretch the teeth of the wheel subjects us to many uncertainties; the tooth is turned to the right or left of the position the point should occupy—so all things considered move up the jewel to the foot of the balance staff, or let the repose cylinder be made larger; this last course has difficulties; if much larger, it will cause the impulse finger

to strike the impulse pin in the scape wheel, when the impulse finger is on the return vibration. Usually the lower hole jewel for a duplex staff is fixed rigidly in the lower plate; should this be the case, break out the jewel and set in a new one, first filing the hole over (as directed in former article), to bring the staff closer to the scape wheel, and then set a jewel in an extra setting, as also described in former article. There is no convenient rule for the amount of advance to be made by the foot hole jewel toward the scape wheel, but the judgment should tell the workman about the right amount. The prejudice some watchmakers have against the duplex escapement is, to a great extent, unfounded; for, if this escapement was free from two drawbacks (liability to damage from breaking of the balance staff, and a possibility of setting or stopping in the pocket), it would be the leading escapement of to-day. A workman frequently gets in his hands fine duplexes of both Swiss and English make, and if he attends to the following instructions he will have very little if any trouble to make them give perfect satisfaction. First ascertain if the watch as it is gives satisfaction; if so clean it if necessary, otherwise let it alone. On the other hand, if the watch does not perform well, and has the reputation of once being an excellent one, but now "worn out, etc.," examine the train well, and if you find this in a good state of preservation, say to your customer: I can make your watch as good as ever it was—but it will cost you something—always make it a rule to get well paid for what you do well; your customer will be better satisfied; and as a rule he will speak better of your workmanship from having to pay well for it. The points to be made in a duplex escapement are to have no more side shake to the pivots of either the scape wheel or balance staff than is absolutely necessary (say $\frac{1}{10}$ of an inch); next, see that the long or repose teeth of the scape wheel are all of absolutely the same length, and that they rest on the jewel roller as indicated at *d*, diagram *B**. And if the watch has been running 15 or 20 years put in a new hardened and tempered hair spring, as the old one is sure to have passed its day of usefulness. To accomplish these results may involve a new scape wheel pinion with new jewels to balance staff or even new balance staff—make up your mind about how to accomplish the results desired and go about the job to secure these results as expeditiously as possible. In setting the escapement set the impulse finger, relative to the slot, in the staff, so that as soon as the impulse finger is safely inside the impulse pin *i*, diagram *D**, the tooth *k* falls from the notch in the staff and the balance gets the full effect of the power. The best method to determine the set of a duplex escapement is to remove the hair spring, and put the balance in place and screw down the cock; when, if the balance is started in the direction of the arrow *l*, diagram *D**; the tooth *k* will fall from the notch in the staff when the acting face of the impulse finger is on the line *j*. If the escapement is all right, and the balance once started, it will revolve rapidly. It is of course understood that after the balance is in place the watch should be partially wound to give power. In putting the watch in beat let the impulse finger stand, when at rest, as indicated at the dotted line *j*. The reader will please excuse the digression made since we left the piece of steel wire turned to the size indicated at fig. 1. The passing slot should now be cut with the graver; this should be done without removing the piece from the lathe, using a round bottom graver producing an incision shaped as shown at *f*, diagram *B**. After the slot is cut and polished, the staff should be roughed out as shown at fig. 3; the point *n* turned down to a cone carefully and broken off; the portion (containing the slot) indicated by the dotted line *p* covered with some anti-scaling compound or castile soap, and the whole staff heated red hot and dropped into water or oil to harden it. The part *p*, where the teeth of the scape wheel acts, should be left very hard; this can be done by putting the staff into a plate of metal as shown at diagram *C**; *o* representing the plate, and *r* the staff. The hardened staff should be whitened or partially polished before putting into the plate *o*, diagram *C**. The staff should fit the hole in the plate *o*, so the plate can be turned over and handled; this is easily

done by broaching out; this plate is as well of brass as anything. By directing a flame with a blow pipe against the portions of the staff protruding out of the plate, the ends can be brought to a bright full blue color, so as to be turned and finished, while the portion protected from heating by the plate *o* will hardly be reduced to a straw color. This course will produce a staff so hard at the part acted upon by the teeth that it will wear almost as long as if it was jeweled. The staff should protrude below the plate from the line *s*, fig. 2, so as to soften enough to turn all below this point. The roughed out staff, as shown in fig. 3, should now be put in a wax chuck, allowing the end *t* to protrude, trueing up by that portion of the staff embraced in *p*, using a pointed piece of peg-wood, as shown at *u*, to true up in the lathe. The pivot at *r* can now be turned and polished, and the staff part where the teeth of the scape wheel acts perfectly polished, as well as the slot *m*. At fig. 2 is shown a finished staff; *u* representing the part where the impulse finger goes, and *v* the seat for the balance. All this part of the staff below *v* should now be finished and polished, when the staff should be removed in the wax, and the upper portion turned and finished; all this is so much like other lathe work that it is not necessary to give any details. It remains to add that, as the moving of the lower hole jewel, to set the escapement closer, will throw the balance staff out of the upright, that some course should be taken to correct this. Generally the steady pins can be manipulated so as to correct the change with the bridge, but, if necessary to move the bridge in any considerable degree, it is better to break out the jewel and upright the hole from the lower plate, and set a jewel in the bridge as recommended for the hole in the lower plate. The writer has recommended the invariable use of fine jewels, and in no place is it more essential than in a duplex escapement, for if the jewels are not almost absolutely perfect the pivots will not have the proper action, either pinching or having too much side shake.

The Jewelers' League.

President, GILBERT T. WOGLOM.....Of Woglom & Miller.
 First Vice-President, JAMES P. SNOW.....Of G. & S. Owen & Co.
 Second Vice-President, HENRY HAVES.....Of Wheeler, Parsons & Hayes.
 Third Vice-President, WM. C. KIMBALL.....Of H. F. Barrows & Co.
 Fourth Vice-President, AUG. KURTZEBORN.....Of L. Bauman Jewelry Co. St. Louis, Mo.
 Secretary and Treasurer, WILLIAM L. SEXTON.....Of Sexton & Cole.

EXECUTIVE COMMITTEE.

JOHN D. LYON, Chairman.....Of Lyon & Hardy.
 JOSEPH B. BOWDEN.....Of J. B. Bowden & Co.
 JAMES D. YERRINGTON.....Of J. D. Yerrington & Co.
 ROBERT A. JOHNSON.....Of Colby & Johnson.
 SAMUEL W. SAXTON.....Of Saxton, Smith & Co.
 CLEMENT B. BISHOP.....Of Carrow, Bishop & Co.

EXAMINING FINANCE COMMITTEE.

CHARLES G. LEWIS.....Of Randel, Baremore & Billings.
 CHAS. G. ALFORD.....Of C. G. Alford & Co.
 GEORGE R. HOWE.....Of Carter, Sloan & Co.

THE JEWELERS' CIRCULAR is the exclusive official paper of the Jewelers' League, and has been selected for the publication of all matters of interest pertaining thereto. Letters or inquiries pertinent to its business or purposes, and which might interest the trade or inquirers, will herein be answered. Address *Jewelers' League, Box 3,444, P. O., New York*, or the office of THE CIRCULAR.

Notwithstanding the extreme hot weather the zealous, persevering, industrious and indomitable Executive Committee of the League, held its regular monthly meeting July 6. Lemonade, with straw attachments, and palm-leaf fans was the order of the day. The death of Milton W. Jackson, of Macon, Miss., was announced. He entered the League August 1st, 1879, and at the time of his death was thirty-six years of age. His death was occasioned by typhoid malaria, his widow being his beneficiary. This is the first death loss the League has been called upon to pay in seven months, and the twentieth since the League was formed in 1877. There has been paid to beneficiaries \$58,670, and hereafter the full benefit of \$5,000 will be paid to each beneficiary as a death occurs. The membership,

now unlimited, is 2,661. On a death occurring each member is assessed, and the amount realized over the \$5,000 required to pay a loss, is allowed to accumulate until sufficient surplus is thus acquired to pay a future loss without assessment.

At the meeting of the Committee forty-one new members were admitted as follows :

I. Weil, C. F. Schanz, Max Lowy, Morris Kraus, Jos. L. Michel, J. D. Farren, Jas. Cary, Jr., Henry Bodenheimer, E. N. Adder, Morris Weisburg, New York City; S. S. Seaman, Chas. Perret, Wm. B. Osgood, Herman Hochweber, R. B. Malloy, G. F. Dobiaecke, Brooklyn, N. Y.; G. P. Titus, J. S. Salkey, Adolph Peabody, Jno. Morse, Chicago, Ill.; August Basse, Quincy, Ill.; John A. Foster, Hugo Florstedt, Newark, N. J.; W. A. Malliet, Greenville, N. J.; Chas. Hadenfeldt, Maurice Block, San Francisco, Cal.; Fred. L. Ripley, Tyrone, Pa.; Alfred H. Murphy, Erie, Pa.; Chas. F. Wenderoth, S. J. Cross, Walla Walla, W. T.; Adolph T. Helfrick, Burlington, Wis.; J. W. Meacham, Milwaukee, Wis.; J. C. Keppler, Glendale, Mon. Ter.; I. H. Johannes, Washington, D. C.; J. A. Daller, Jackson, Mich.; R. T. Bates, Urbana, Ohio; T. J. Ash, Port Perry, Ont., Can.; C. Dobra, No. Attleboro, Mass.; J. H. Tarr, Providence, R. I.; F. H. Bohne, New Orleans, La.

One application was rejected and ten were laid over for further investigation. An assessment was ordered, \$2 upon each member, to pay the death loss above mentioned, and the amount, \$4,892.50 was promptly paid to the widow of Mr. Jackson. There were six applications for change of beneficiaries, which were granted, and the meeting closed in peace and harmony, and in due and ancient form.

Sight.

WHAT THE OPTICIAN SHOULD KNOW ABOUT OPTICS.

Based upon an extensive hospital experience in Austria, Germany, England and New York. By C. A. BUCKLIN, M. D., New York. Author of Detection and Correction of Visual Imperfections, Cause and Cure of Cross Eyes, Effects of Color on Distance, and Monograph on Astigmatism.

Continued from page 185.

Dr. Bucklin:

DEAR SIR.—A few months ago my eyes were sore and inflamed. Mornings they would be so full of matter that I was obliged to wet them before I could get them open. I was troubled in this way for a few days. Since that time they have been dry or heavy nights, after I closed them for a time. Mornings I have to rub them before I can open them. They seem to be dry, and cause much pain if I try to open or turn them before I rub them. Some mornings they are worse than others. After I get thoroughly awake, I can see as well as ever. They do not trouble me in the day time, and I have always had good eyesight. I am twenty-one years old, and have worked at the jewelry business for several years. Any advice you can give me will be thankfully received. Most respectfully,
Milford, Ct., July 6th, 1883. F. B. C.

You have had acute inflammation of the conjunctive. You should wash your eyes frequently with cold water; at the same time snuff water through your nose till you feel it come through in your throat. The trouble frequently extends from the nose to the eyes.

You should use an eye water three times a day, containing one grain of sulphate of zinc to the ounce of water. This will cure the trouble inside of two weeks, providing the eyelids have not become granular.

They will require touching three or four times a week very gently with a smooth crystal of sulphate of copper; after each treatment the copper should be washed from the lids with water. This treatment causes some little pain, but it is the easiest and only method of curing granular eyelids.

Months are frequently required to cure granular eyelids. I think the eye water above mentioned will cure your eyes. Try it, and let us hear from you.

The next is a long letter from E. B. Bramm, Boise City. He has myopia, with considerable degree of myopic astigmatism.

I don't think it necessary for him to leave his trade, if he is doing well, and knows of no other opening where he can do as well. If other employment can be found, where he can do just as well, I would prefer to let some other person do the watch work.

I find that experimenting in prescribing cylindrical lenses for persons I have had no opportunity to examine personally is very expensive. I am obliged to pay for the lenses whether they are satisfactory or not, and if they are perfectly satisfactory, I am never sure of recovering the money I lay out. I should advise Mr. B. to work without glasses, and to wear No. 18 concave to see in the distance with. If he ever comes to New York, I shall be pleased to tell him what combination of lenses will give him the best vision.

July 11th, 1883.

Dr. Bucklin:

DEAR SIR.—I am a watchmaker, and having read your articles in THE CIRCULAR, also your work, "Visual Imperfections," have, as the result, discovered that I have some of the symptoms of glaucoma. I see a misty circle around a light; I think there are three colors in the circle of mist: red, yellow, and green, as below represented in pencil. I don't see the appearance every time I look at a light, but quite often lately. My eyes "ache" or have a feeling something like a dull or undecided ache, after working all day at the bench. They sometimes feel as if they had a tear in them, and as I try to look, it is like looking through tears. There is a black spot or a kind of feathery-looking spot, grayish, about the size of two pin heads, that floats before one eye at times, not always. Sometimes when I look at a light, the circles around it do not have any color in them, only circles of light. Sometimes after looking at a light for a few seconds, and taking my eyes off from it and looking at the wall or ceiling, I see a misty green spot about as large as a fifty-cent piece, with three to four small red spots in the center of it. The red spots are longer than wide.

Please let me hear from you by return mail what I had better do, and what the expense will be. I would like to have you attend to the matter above anyone I know. Yours respectfully, J. D. H.

P. S.—Please let me know what the above symptoms indicate, as near as you can judge. J. D. H.

P. S.—My health is not extremely good, although I am able to work all the time. I have about the average health of people confined in stores, am of a nervous temperament, and thirty-one years old. J. D. H.

Have no myopia, no hypermetropia, no muscular asthenopia, eyes emmetropic or normal. Had my eyes examined a year ago by Rider, of Rochester, and don't remember of noticing the misty appearance about a light until lately, or within two or three months.

J. D. H.

I read considerable mornings and evenings, and Sundays.

Mr. J. D. H.'s eyes promise to give him trouble. The red spots are probably small retinal hemorrhages, and all the other glaucomatous symptoms are probably secondary to these small hemorrhages.

These symptoms, as described by him, indicate grave trouble. view them as you may. I would not on any account use my eyes while they were in this condition. You better make it your business to look out for your eyes.

July 11th, 1883.

To the Editor of the Jewelers' Circular:

DEAR SIR.—Will Dr. C. A. Bucklin be kind enough to read the inclosed circulars, and tell the jewelers who aspire to be well informed in optics, so as to intelligently fit spectacles, how far the advertising "Opticians" are right in their claims. I read in Wells' work on "Long, Short and Weak Sight," that spectacles are sometimes required to have lenses of different focus in lower and upper part, and "in Paris such lenses are called *verres à double foyer*," and that "Franklin wore such spectacles;" but I am informed by this circular that Clark is the "inventor of the combination glass." Also in another circular which I enclose, we have the startling information that they have the finest "eye test" in the world, and only one in the state, Dr. C. A. Bucklin and all other oculists left in the shade. Is it possible to make an instrument that will discover either hypermetropia, myopia, or presbyopia in a person's eye, by that person's simply looking in it, and the operator moving a certain part of it until said person sees plainly, thereby registering the number and kind of glass needed? Also, what are the "student" glasses spoken

about? I read in Wells' work that sometimes emmetropic eyes are afflicted with asthenopia by overwork, and that we should give to such persons a glass that would make rays of light coming from an object a short distance from the eyes (for reading or near work, I suppose) parallel, so such rays would enter the eye parallel and thereby not exert the accommodation; in so doing, would not the reading or letters be indistinct from the accommodation not relaxing when the eyes are converged for a short distance? For instance, if we should give a No. 16 glass and hold the book sixteen inches from the eyes. Yours respectfully,
J. D. HOWELL.

The Clark Bros., like all other individuals, are after money. To do this they advertise in such a way as to make capital out of the credulity of an ignorant public. If they would adhere strictly to the truth, the trade could not say much against them, because they make money out of the public without gaining their confidence in the usual time-honored way. The first claim you mention in your letter about their being the inventors of spectacles containing double foci is not true.

Mr. Boeringer has arranged lenses in a disk which he rotates before the eye. When the lens comes around, through which the patient sees the best, this is the lens to be given. Mr. B. claims a patent on this device, and calls it his optometer.

It simply amounts to giving the person different lenses to look through.

If the device were original, I would speak more at length of it. At present it is the best device known as an optometer.

There is still another instrument where lenses are mounted in pairs, and placed in a box like the pictures in a stereoscope. When the lens comes around through which the person sees the best, it is the number given. These two instruments give nearly as good results as trying the lenses before the eyes in frames, as is usually done. The work can be done more rapidly. With the instrument you cannot do anything that you could not do without it. I never have seen a *bar optometer* of any description, which gave satisfactory results.

Student glasses is a term of his own invention. They are convex lenses for persons who have weak accommodation, or for those who have simple hyperopia. They are no different from any other convex lens.

In a person who is not hyperopic or presbyopic, a convex No. 16 lens would usually produce unpleasant disturbance in the relations existing between accommodation and convergence.

As far as I can judge from reading the circular and your letter, the wise optician knows much less about the theory of optics than you do. You will find, however, that the one who understands optics best, does not always make the most money.

Perpetual Motion.

ALTHOUGH the subject of perpetual motion is irrelevant to the aims of THE JEWELERS' CIRCULAR, we quote the following pithy remarks from a German author:

"The fables of the sea serpent and of perpetual motion are deathless, and may be suddenly encountered in newspapers and periodicals, when least expected. Especially the latter, giving in glowing detail the wondrous end finally accomplished, or describing machinery *nearly* ready. These fanciful reports are even copied at times by trade papers which ought to be better informed, and therefore are calculated to lead numerous artisans astray.

"Let us never forget that all our machinery solely transmits the power imparted to them by the motor, but they *never* create new force, and this truth will give all perpetual motion schemes the death blow. It is true, we employ natural forces offered us, such as the muscular power of man and animal, the velocity of water currents, the motion of the air, etc., and cause them to operate upon our machinery, by deflecting them for the purpose—but that living power offered to us by those forces will constantly decrease.

"To construct a perpetual motion signifies the constructing of a working machine which, not being impelled by any other force, creates its own—becomes its own motor. * * *

"Let us always stick to the truth that a machine can only serve the purpose of *transmitting* the effect of a motor, to conquer resistances, whereby the total amount of force of the motor is not increased, but lessened by the obstacles to be conquered—wherefore the invention of a perpetual motion is not alone improbable, but it becomes a sheer physical impossibility.

"The majority of inventors seek to accomplish this end by aid of a falling body, constructing machinery which shall lift such falling body back to its original height, and using the work produced thereby at the same time. Many of them used balls falling or rolling upon an inclined plane; others desired to use falling water pumped by its own power, etc.; but all overlooked the fact that a falling body, leaving out of the question for the nonce all resistance encountered, can only lift itself to its original height, but will never be able to create working power thereby; and this axiom will at once inform us of the fallacy of perpetual motion, created by weight, gas, fluid, elasticity or pressure."

* * * * *

How to Grind and Polish Pallet Jewels.

BY EXPERT.

SOME MONTHS since I gave the method for grinding and setting close pallets, and in the present article I propose to give the details of making and finishing exposed pallets. As this journal has so many new subscribers I shall in part repeat some of the things said then in regard to close pallets, as well as give cuts of the necessary laps for grinding and polishing. At fig. 1 is shown the ordinary roughing out lap for shaping the pallets; this can be made by an old-fashioned copper cent, riveted on to a brass chuck for screwing into your lathe (either American or any live spindle lathe). The face of this lap is charged by burnishing in fine particles of diamond powder. The next tool is the one for making the little slabs of garnet for the pallet. I say garnet because nineteen-twentieths of all the pallet jewels used are of garnet. Ruby pallet jewels are used in very fine Swiss watches, but if you had to make one it would be extremely difficult to get a proper stone to commence with, and in all probability it would cost you more for a stone than you would have to pay for a ruby pallet of some of the large material dealers in New York City. Moreover, a good highly-polished garnet would in all practical senses answer every purpose. At *A B*, fig. 2, is shown a disc of soft steel $\frac{1}{2}$ inch in diameter, with a hole through the center at *e*; into this hole is tapped a plug, shown at *f*; this plug is fitted with a very fine screw. This screw is run in until the face becomes flush with the line *s*, when the face of the disc *d* and the end of the screw *f* are ground off flat. If now the screw *f* is retracted a recess is left as shown at *e*. We now take a large size cap jewel and place in the recess *e*, and apply the disc *d* to the face of the diamond lap *a*, fig. 1, as shown at *g*. The cap jewel and face of diamond lap are kept wet with water or saliva. If the diamond lap is given a rapid motion it will soon grind away the protruding portion of the cap jewel. At *D* is shown a cap jewel (magnified), and the dotted line at *h* indicates the extent to which it will be ground away. It will be seen that by turning the screw *f* any thickness of garnet slab can be produced. If we used a nicely finished cap jewel, one side of the slab will be polished; the remaining work to be done is to polish the side we have just ground, and then shape out our jewel and polish it. The details are as follows: the slip of garnet is cemented to a brass disc, as shown at *i*, fig. 3, the two circles shown at *j j*, can either be screws or other slabs of garnet. The idea is to get these points to rest on the polishing lap. A copper lap is used to polish with exactly like the diamond lap, except it is not charged

with diamond dust, but the face of the polishing lap is kept smeared with rotten stone and water. The polishing is continued until the garnet slab is perfectly polished; it is now ready to be shaped; this is done by inserting the garnet slip into the edge of a piece of hard sheet brass shaped as shown at G^* . It is necessary to have one square end to our pallet stone, which goes to the bottom of the slot it is inserted into in the pallet; the dotted line at k , diagram K^* , shows where this cut is made, and ll the sides of the pallet stone. A pair of heavy tweezers coated with beeswax will hold the garnet slab to grind to the line k . The piece of brass, G , should not be as thick as the width of the pallet stone; at m are two notches cut into the edge of this brass piece not quite as deep as the length of the pallet stone, and it will be seen that they are not both at the same angle, as one is for the entering pallet and the other for the exit pallet. The notch at n is to grind the edge of the garnet slip square on the line k , if the reader prefers not to use the tweezers as directed above. At P is shown an end view of the brass piece G as seen in the direction of the arrow o , diagram G^* . Fig. 4 is a plan of the arrangement for grinding the edges of the pallet stone; F represents

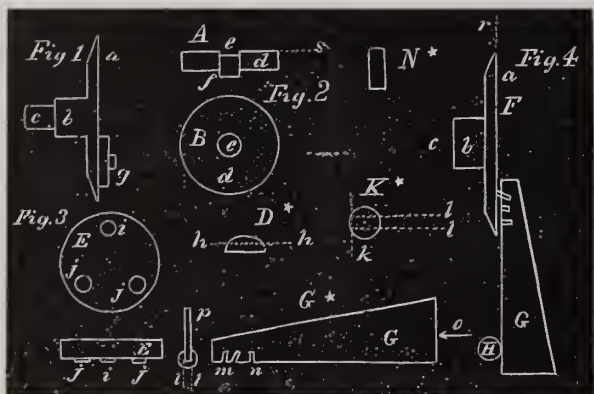

the copper lap; H a piece of large wire going into the rest holder of your lathe. It will be seen that if a slab of garnet is inserted in one of the notches shown at m , and cemented in with shellac, that if we put one end of the piece G against the piece of large wire shown at H , and let the other end of G carry the garnet slab against the diamond lap shown at F , fig. 4, that the edge of the garnet slab will be ground to a bevel, this bevel being governed partly by the direction of the incision as shown at m , diagram G^* , and partly by the position of the wire piece H . The lap F , fig. 4, can be either the diamond roughing out lap, or the one for polishing, if the length of the piece b , as shown at fig. 4, is the same. That is, you can first put in your diamond lap and grind off the end of the stone to the length required, and then remove the diamond lap and put in the polishing lap, and if the faces of both laps come to the same line as at the dotted line r , the angle must be the same, and your pallet polish up correct and quickly. The piece G is held horizontally between the thumb and finger, letting the end resting on the lap point toward the center. By giving the piece G a slight rocking motion the protruding end can be ground convex, as shown at N^* . The sides of the pallet can now be ground by letting the piece G rest flat against H , while the garnet slab rests on the mill F ; the sides are alternated until ground down nearly to the brass, but in no case should the grinding extend quite to the brass. In practice the little garnet slab (after the edge at k , diagram K^* , is ground off), is cemented into the brass piece G , as shown at p , and by presenting the edge and sides to the diamond lap (F) the pallet is shaped as shown at N^* . Now change the diamond lap and put in the rotten stone one and polish what you have already ground and you will have your pallet as nice as you can buy. By having these notches at m you can grind and polish these pallets at once, and in one sense this is best, as you need these pieces at the operation shown in fig. 3. This process of grinding pallets is very simple, and should not be attended with any annoyance; the only trouble the novice experiences will be in the diamond lap cutting rough, and in a measure destroying the corners of the pallet. This need not be the case if your diamond dust is fine with

which you charge your lap, but either of two courses will perfectly remedy it. First, by using two diamond laps; number one charged as directed above, and used with water, while number two lap should be of soft steel and used with oil and intensely fine diamond powder. To do this quite a quantity of finely crushed diamond should be placed in a small bottle with some watch oil, and when you need to use some of it the bottle should be shaken, so as to mingle the oil and particles of diamond; after the bottle has been quiet for a few seconds an instrument like a large oiling tool can be dipped in the mixture, as fine particles of diamond are floating still in the oil, and applied to the face of the steel lap. This kind of a lap cuts rapidly and without scratches. The reader will understand that the longer the bottle containing the oil and diamond dust remains after shaking, the finer will be the particles left suspended, and nearer to a polish will the grinding be. This system is the one used to produce ruby pallets, but the graduations must be carefully made, and the last lap used must be moistened with oil which has been allowed to settle for at least one hour. For the ordinary trade a better course to pursue is, if you find any trouble with the diamond lap cutting too rough, to prepare a third copper lap, using the precaution to let all the faces come exactly to the line r , fig. 4. The third lap is to be used after the diamond lap has roughed out the pallet in the piece G . Emery and water is used on the face as directed for the bottom stone. The emery to be used is the same as diamond pointed pen makers use to grind their iridium points; it is extremely fine. If you get gold pens re-pointed, the party who does the work for you will sell you an ounce for a trifle. This, with water, on your third lap will soon grind out any scratches and bring up the corners clean and sharp. After the emery grinding is done wash your job, and polish with rotten stone as directed. I said above, in speaking of using diamond dust in oil, of quite a quantity being necessary, as this is indefinite, say, $\frac{1}{4}$ of a karat, and one drachm of oil. If unable to obtain the emery mentioned, put an ounce of flour of emery into a six ounce bottle; fill the bottle nearly full of water, shake well, let it stand one minute, then, with a splinter of wood, apply a little of the water and emery to the emery lap. This course will allow the large coarse emery to fall, and you will use emery as fine as the pen pointers.

Advice to Watchmakers' Apprentices.

BY A MAN WHO HAS SPENT TWENTY YEARS AT THE BENCH.

WORKING gold into various articles of jewelry is an art which has been practiced by the human family for a good many thousand years, and still it is one in which we are learning something every day. It is not the writer's intention to go into all the details of gold working, but rather to give such instructions as will enable a workman situated so that any little article he may desire to make of gold he can do so, without the expense and delay of sending to some large city. In gold working it is well to make your alloy from coin, as to work up your scraps or such bits of old gold as will accumulate is generally attended with more or less annoyance and vexation. If you have scraps and filings, or old gold jewelry, melt it up and sell it to some person who makes a business of refining. Your loss will be less than if you attempt to purify and work it yourself. Any refiner will give you to within one cent a pennyweight of the actual worth of any scrap. It should be melted into a button as will be described further along. On estimating gold it is usual to allow four cents per pennyweight for every karat fine; this is only an approximate method, for it is really worth more; an ounce (Troy) of pure (24 karat) gold being worth \$20.67,183+. And an ounce of standard coin gold being worth \$18.60,465+. The American mint standard being 900 parts of gold to the 1,000. The English mint standard is a trifle finer, being $\frac{22}{24}$ or twenty-two karats fine; in decimals it would be 916+ to the 1,000. In melting gold it

is best to use a black lead crucible; those with a cover on some accounts being preferable. Such crucibles will last for a great number of meltings; that is, the same crucible can be used forty or fifty times if carefully handled. In new crucibles a little charcoal powder should be put in the bottom. In one of my early articles I gave the form of a furnace for heating steel tools for forging and tempering, and also spoke of its being adapted for melting gold. An ordinary stove-coal stove answers very well, but charcoal or coke should be used for fuel, and the fire kept as clear and free from ashes as possible for no matter how prudent one may be, accidents will sometimes happen, and a crucible breaks, and your gold is mixed with the coals and ashes. Then comes the delay and annoyance of recovering your gold, and, of course, it is evident that the less cinders and ashes the better. Some of the new styles of gas or petroleum furnaces for melting gold are about the cleanest affairs going, and for this purpose are just the thing. We will first speak of 18 karat gold, as this is so much used for plain gold rings. This alloy is in some respects by far the most disagreeable and unpleasant made to work, cracking and breaking in a most disheartening manner. This can be avoided generally in the alloying, and if the formula given below is followed, favorable results may be almost invariably expected. Care must be taken to select such copper for the alloy as is entirely free from all traces of lead and tin. Copper prepared for jewelers use can be obtained of all our material men; but in absence of this, old English and Swiss watch dial copper can be used; as also the metallic copper which collects in and around some kinds of galvanic batteries. The color of the alloy depends on the metals used in the composition; if a very red alloy is desired pure copper is only added, and for such an alloy, pure gold to be obtained of the refiners or English sovereigns must be used, as American coins are alloyed with a mixture of silver and copper. It is well to say here that an 18 karat alloy of too much copper is extremely difficult to work, and for this reason it is better to let the percentage of silver be as given below. An 18 karat alloy of gold and copper used to be much used in France and England, and consisted of 18 parts pure gold and 6 of copper; such an alloy is almost as red as a copper cent. A good composition for 18 karat rings or other jewelry is, if we use pure gold: 18 parts gold, $2\frac{1}{2}$ parts silver coin, $3\frac{1}{2}$ parts pure copper. If we use gold coin, say a 20 dollar gold piece weighing 516 grains Troy; here we have 464.4 grains pure gold, 51.6 grains alloy (equal parts of silver and copper), to which must be added 42 grains of pure copper and 23 grains of pure silver, producing the same alloy as above. In melting there should be a little charcoal dust put in the crucible first, if the crucible is a new one; then the copper; on top of this the silver; above all the gold; that is in the order of their gravity, the lightest at the bottom; when you see the mass is about to melt, throw into the crucible a tablespoon full of fine charcoal powder. This coal dust can be made by rubbing a lump of charcoal on a common tin grater. This fine charcoal powder forms a coating on the gold and prevents the air from acting on it. As soon as the gold is perfectly melted, it is to be stirred with a pointed rod of iron (made red hot at the point), to mingle the metals. The gold in the crucible can now be cast in the ingot mould. This ingot mould should be greased and heated up to near the boiling point of water, about 200 degrees F., or just so the hand can bear to hold it for a second or two. If you desire a very tough gold add to the charcoal dust a like amount of sal-ammoniac, letting the sal-ammoniac burn out, leaving the charcoal powder covering the gold; pour now as before into the ingot mould. The ingot mould is too frequently seen to need any description. Care must be used in pouring; and it is well to proceed as follows: After the gold is up to a white heat and perfectly fluid, the crucible is removed, and a piece of thin wood is held in the left hand, and as the crucible is tilted up to pour, the flux is held back with the slip of thin board; poplar, such as some kinds of cigar boxes are made of, is the best. Simple as this reads it requires some skill to pour the gold quickly and free from the flux. Many jewelers use common

salt as a flux for melting and recommend its use as preferable to anything else, but the same objection to its use can be urged as against borax, and that is, it is liable to get into the ingot mould, and leave itself embedded in the gold, and when it comes to rolling it forces the glass like substance into the metal. But sal-ammoniac and charcoal is perfectly free from these objections, and produces a gold tough and in every way reliable. If the reader desires to melt up his scraps, he should thoroughly go through it with a magnet to remove all iron and steel particles, then melt with the following flux: two parts of carbonate of potash (sal tartar), and one part of nitrate of potash (saltpeter). If the gold still refuses to roll, and cracks or splits, there must be lead or tin, or perhaps both, in the shape of soft solder in the composition, and a percentage of $\frac{1}{1000}$ part renders gold unworkable. Gold containing lead or tin when broken does not present a good grain, but looks close and pale. To remedy this remelt your gold with a flux of two parts of charcoal and one of corrosive sublimate (bi-chloride of mercury). Look out about the fumes as they are poisonous. In our next we will give the plan of a furnace using coal gas or petroleum vapor, as well as instruction in casting various articles.

Manufacture of Artificial Jewels.

[From *Central Anzeiger*.]

WHAT BOXWOOD is to the wood engraver, comparatively speaking, is chalcedony to the cameo cutter. Hard, without being brittle, capable of assuming a high and durable polish, embellished by nature with handsome, and at the same time sharply contrasting colors, or at least inclined to assume them from the hand of man, are its distinguishing features, it has, from the earliest period of the art of jewel cutting, not alone been a favorite but also the only available material for cutting gems.

The ordinary chalcedony is a white, almost transparent stone, which in antiquity was used for lance and arrow heads, and in modern times for flint stones. Only after it receives a handsome color by metallic oxide, especially iron, is it raised to the rank of a jewel, no matter whether this color is unicolored brown, yellow, red, or green, as jasper, chrysopras, etc., or whether it is banded with lighter or darker layers, like the agate, onyx, cornelian, etc.

The majority of the chalcedonies undoubtedly owe their origin to the agency of water, since this, especially at a higher temperature and increased pressure, is capable of dissolving the chief constituent of this stone, silicic acid, and of depositing it again at normal conditions, the color, however, has plainly been produced by the operation of metallic oxides, in consequence of the influence of heat.

Art can do the same, and the simplest process is to produce the cloudy or latent color of the jewel by heating. The celebrated precious chalcedonies of India were manufactured from the cloudy brown stones by heating them in a layer of camel or cow dung, whereby too high a temperature could be carefully avoided. A heat capable of charring wood, produces here the same process which takes place in the burning of bricks, the yellow brown hydroxide of iron is changed into the red peroxide of iron, whereby the beauty of the color of the stone is largely enhanced. In Oberstein, in Germany, the main seat of manufacture of these jewels, the same method is in vogue, and the temperature of the furnace is carefully observed. The non-impregnated chalcedonies generally turn white by the heat, since the texture of the transparent stone is destroyed by the heat. The snow-white bands of the onyx, which make it peculiarly suitable for cameo cutting, are mostly always produced artificially in this manner, the color of the darker layers being developed in a handsomely contrasting manner with the white color of the adjoining layer.

But art goes still farther, by introducing the colors into the stone, and thereby it is capable of producing far greater effects than nature.

The pigment must be conditioned thus that it can be precipitated by heat or chemical effects. If a gray chalcedony is to be converted into a precious one, it is dipped into a solution of nitrate of iron, which is prepared by dissolving old nails in dilute nitric acid. Red peroxide of iron is formed by the effect of the heat, and the arising color is light or dark, according to the quantity of the absorbed solution. The more transparent the stone, the longer it must lie in the solution, and if it contain unequally transparent layers, the same kind of colored bands will be obtained. Black onyxes, that is, stones possessing alternating black and white bands, are always artificial.

The coloring substance is coal, which is introduced in a colorless solution, and produced by heat or sulphuric acid. According to the Oriental, which is also the oldest method, the stones are first boiled in honey or oil, at repeated times for weeks, and then heated to a temperature which chars the vegetable substance in the pores of the stone, and produces black or brown, according to the quantity absorbed. The deepest and most durable black is produced in this manner, but since the stone is very prone to crack, whereby it is ruined, Europeans prefer to effect the carbonization by means of the influence of sulphuric acid.

The Oriental black was for a long time regarded as a natural color, since it resists longer the influence of nitric acid, a quality not shared by the black generated with sulphuric acid. Although it was found out lately, that by a sufficiently long exposure the Oriental black is also attacked.

The yellowish brown, orange, and lemon tints of the chalcedony are artificial, and may be produced by methods which are analogous to the above described ones. The citron yellow colors are produced by permitting hydrochloric acid to operate upon the almost transparent stone, which in a natural way has absorbed a small quantity of sesquioxide of iron, and the other two by dipping the stone in a neutral solution of nitrate of iron, and exposing it afterward to the sunlight.

The pale green color of the chrysopras may in a transparent chalcedony be originated by a bath which has been saturated with nitrate of nickel; it is worthy of remark that this color is not produced best by the chemically pure nickel salt, but by that which still contains a trace of cobalt. It is necessary to submit the stone for three or four weeks to the action of the bath.

A blue color is more easily produced, but it is not durable. The pigment is Prussian blue, which is precipitated in the pores of the stone, by causing ferrocyanide of potash to operate upon sesquioxide of iron, which was already introduced into the stone by the above indicated method for producing red. A still better effect is obtained by first dipping the stone in a bath of ferrocyanide of potash, and after that into a solution of sesquioxide of iron.

Curiosities of Clocks and Watches.

ABOUT 1796, some missionaries took with them to one of the Friendly Islands, among other things, an assortment of cuckoo clocks, which soon became objects of wonder and interest to the natives, who entertained the opinion that a spirit spoke in them, and would inform on anyone who should steal anything from the ship or missionaries. Tooghowe, one of the natives, stood in such awe of them that he would not have one of them in his house. His father, however, regarded them in a different light; when he found himself dangerously ill, he requested that some of the brethren would come and sing psalms for him, and bring a cuckoo clock to assist in healing him. The high priest, knowing perhaps the mysteries of his own profession, was exceedingly delighted with these clocks, desired to have one, and as soon as he got it home, took it to pieces to examine the inside. It was beyond his skill, however, to put it together again, and unluckily, also, beyond that of the missionaries. None of them had been instructed in this branch of mechanism, and

the discovery of their ignorance excited the contempt of the natives.

Early in the present century the tower of the Metropolitan Church of La Zeu, at Zaragossa, was finished from designs made in 1683. The allegorical statues of Time and Vigilance support the dial of a clock in the second story of this tower; but, considering how lazily life flows along in Spain, there seems to be a touch of satire in this public hint. The cathedral at Toledo has two old lateral gates, one of which is called the Relox, or the clock house, and also the Lost Child. The clock itself is placed in a handsome and comparatively modern tower.

A writer, in 1809, tells us that in the Mansion House at Palma, in the island of Majorca, there was a clock called by some the Balearic, and by others the Clock of the Sun, and well worthy an examination. No one was able to say where it was made or whence it came. It marked and struck the different hours of the days and nights according to the progress of the sun and the different solstices; and it was generally admitted to be the only one of its kind in the world.

In the English *Gentleman's Magazine*, for 1816, we read that at a small town in Devonshire, there existed a custom that every morning and evening soon after the church clock had struck five and nine, a bell from the small steeple announced by distinct strokes the number of the day of the month. This probably was originally intended for the information of the unlearned villagers.

At the clock gate of Berne, Switzerland, about half way between the pavement and the pinnacle, is a large party of wooden bears dressed like soldiers of the olden time, in coat, armor, and garb-dines; some bearing a halberd and others matchlocks, and accompanied by several other bears, who act in the capacity of trumpeters and little drummers. Directly the clock begins to strike the hour this company marches out of a little tower attached to the dial square, and after nodding their heads to the people, walk to their original quarters. Above them sits an old pantaloon with spectacles across his nose, acting as dummy on the occasion, and not far from him is a clown, who, seated like an Indian juggler, obeys the summons of the hour by striking, in return, two bells, right and left, shaking his head meanwhile very whimsically. At the extreme top of the clock tower, under a kind of belfry, stands a large figure in armor to strike the hour on a great bell. This exalted personage is frequently mistaken for a plumber mending the clock-works. Beside all this, immediately above the arch of the gate is stationed a cock of gay and golden plumage, as large as life, which claps its wings and crows almost as genuinely as the real bird; an effect which is produced by mechanism acting on some organ stops. The redoubtable name of this clock tower is Zeitglockenthurm.

Longfellow, in his "Hyperion," tells us that in the belfry of the Kaufhaus in Coblenz, is a huge head with a brazen helmet and a beard; and whatever the clock strikes, at each stroke of the hammer this giant's head opens its great jaws and smites its teeth together, as if, like the brazen head of Friar Bacon, it would say, "Time was; Time is; Time is past." This figure is known through all the country round about as "The man in the Custom-house;" and when a friend in the country meets a friend from Coblenz, instead of saying, "How are all the good people in Coblenz?" he says, "How is the man in the Custom-house?" Thus the giant has a great part to play in the town.

The *Bibliothèque Universelle* (a Swiss Review), records particulars of a man by the name of J. D. Chevalley, a native of Switzerland, who had in 1825, at the age of 66, arrived at an astonishing degree of perfection in reckoning time by an internal movement. He was, in fact, a human timepiece. In his youth he was accustomed to pay great attention to the ringing of bells and the oscillations of pendulums, and by degrees he acquired the power of counting a succession of intervals exactly equal to those which the vibrations or sounds produced. Being on board a steamboat on the lake of Geneva, on July 14, 1823, he engaged to indicate to the crowd about

him the lapse of a quarter of an hour, or as many minutes and seconds as any one chose to name, and this during a very lively conversation with those standing by; and further, to indicate by his voice the moment when the hand passed over the quarter, minutes, or half-minutes, or any other subdivision previously stipulated, during the whole course of the experiment. This he did, without mistake, notwithstanding the exertions of those around him to distract his attention, and clapped his hand at the conclusion of the fixed time. His own account of this gift was as follows: "I have acquired by imitation, labor and patience, a movement which neither thoughts, nor labor, nor anything can stop. It is similar to that of a pendulum, which at each motion of going and returning gives one the space of three seconds, so that twenty of them make a minute, and these I add to others continually."

Wooden Watches.

AN OLD Swiss preacher, Herr Gaberel, recently laid before the Horological Union of Geneva, an article interesting for two reasons. It was a wooden watch which had belonged to the celebrated philosopher Jean Jacques Rousseau, who, as is well known, was a citizen of Geneva.

Although wooden watches are not in everyday use, it must not be supposed that the present work is unique, since it appears that in the course of the last century several such oddities were manufactured in Geneva. A member of above said union, Herr Alexis Favre, reminded his colleagues on the fact that in 1873 two wooden watches were exhibited at the World's Fair at Vienna, of which the report of the exposition gave the following data:

"In the Russian division may be seen ranged alongside a superb electro-magnetic chronometer, two other artistic productions of horology, which although without practical value, are worthy of special mention on account of their extremely delicate execution." They consisted of two 19-line wooden watches with cylinder escapement, manufactured by a wood carver. They preserve an excellent rate; I have wound one of them to observe it, and to my great surprise it performed well. Only the balance spring and mainspring are of metal, the finely finished scape wheels are of hard wood, as well as all the other wheels; their tothing is very neatly and delicately finished; the well-worked clickwork, the screws, in short everything, is constructed from wood, even the case with its joints, and renders excellent service; the pivots and cylinders are of bone. If some one would undertake to imitate even one single part of these watches he would at once comprehend the magnitude of the entire construction.

The movement of the watch presented by Herr Gaberel also is of wood, except the pivots, scapewheel, spindle, chain, arbor of barrel, dial, and naturally the mainspring and balance spring; the hands have been lost. The wheel tothing is well executed, in short, everything proves that the manufacturer of the work was a most skillful artist; all watchmakers present declared that it would almost be impossible to manufacture such a piece of mechanism at the present day; it is also well that wooden watches are no longer in demand. Upon the case of the watch is engraved in excellent style and bold letters

J. J. Rousseau—Genève, 1766.

The watch was contained in a box which had also been the property of the celebrated philosopher.

Even admitting that a limited number of wooden watches is in existence, it may be accepted as beyond a doubt that one of them, which once belonged to Rousseau, must be unique of its kind. It is well known that many articles with a tradition of once having been the property of celebrated men are found in market, but in this instance it may safely be assumed that the title can be clearly proven by the following facts:

During the reign of Louis XVI., the Secretary of the Russian Embassy lived in Paris, who was at the same time an ardent admirer of Rousseau and his writings; he was successful in obtaining admission to Ermenonville, and to enter into friendly relations with the Genevan citizen. After the latter's death he obtained from the equally very famous Thérèse Levasseur several articles from the estate, which, doubtlessly, he had very dearly to pay for. They consisted chiefly of books, among which a very handsome copy of "Emile," and the watch in question which Rousseau wore during the latter part of his life, and which he undoubtedly purchased during his residence in Geneva, as he himself acknowledges in his "Confessions."

At the outbreak of the French revolution the secretary retired to his home at Dorpat, where he died at an advanced age and left a daughter still living at an age of 82, and a cousin of Madame Gaberel. During the occasion of a visit to her relation, the latter lady presented to the former a copy of a work published by her husband, Mr. Gaberel, to commemorate the centennial of Rousseau's death, and she received said watch as counter present.

Since Mr. Gaberel desires to leave this historical piece as a present to some collection, the museum of the horological school was recommended to him. It is not alone an object of curiosity, but it may serve at the same time to show to our acquiring youth what our forefathers in the art could do with their imperfect utensils, since this watch offers far greater difficulties in its execution than those used at present.

Transmission of Power.

THE UNIFORM transmission of motive power from the barrel through the train to the escapement is a matter of great importance. This uniformity can only be obtained by good depthings; and since it is well known that depthings are more perfect with the higher numbered pinions, it is advisable never to have the center pinion with less than 12 leaves, the third and fourth wheel pinions with 10, and the scape pinion with at least 7. The difference resulting herefrom in the art of manufacturing is so very trifling that it cannot be an obstacle to making even low grade watches with these numbers.

It must be admitted that the center pinion will become more delicately, hereby, and more liable to injury by the sudden jerk resulting from a rupture of the mainspring, or by the pressure occasioned through careless winding. The teeth of the barrel, too, being necessarily thinner, will be more apt to bend from the same causes; but this is partly remedied by the fact that with a pinion of twelve leaves, there are in almost every moment, two teeth of the barrel acting at the same time on two leaves of the pinion, while in the lower numbered pinions one tooth alone has to lead through a more or less extended angle. Any sudden shock will in this manner be divided between two teeth of the pinion of twelve, and sustained in the same way by two teeth of the barrel belonging to it, whereby the apparent danger is greatly diminished. Besides, the finer tothing producing a better transmission of power, a weaker mainspring may be used, and in case of its rupture the shock will be less violent.

One of the main conditions for a good and uniform transmission of power is a good and suitable shape of the wheel teeth; and it is astonishing to see in what an indifferent way this important matter is treated. It is a well known fact that the wheel teeth, in order to act properly ought to have an epicycloidal rounding, and no engineer would suffer any other form for the teeth of starwheels. Berthoud treated this subject in a most elaborate way about a century ago; Reid and others have also explained the principles of the construction of toothed wheels most explicitly, but in vain. It seems that the greater part of the horological fraternity have resolved to view

the shape of their wheel teeth as a matter of taste. All the wheels of English and other makers, with very few exceptions, impart to their teeth a shape defying the rules of Berthoud, Reid, and other masters—a shape of which nothing can be said except that they look very nice in the eyes of those that make them, or those who use them, and say, "They look much better indeed than those ugly pointed teeth." There is no possibility of being successful against arguments like these, and I have known many a respectable and good watchmaker who declared that he could not bear the sight of teeth with an epicycloidal rounding. This is a subject, however, that should be well studied by every watchmaker.—M. GROSSMANN, in *Allg. Journ. d. Uhrm.*

The Great Need of Theoretical Instruction in Horology.

MANY YEARS ago, the celebrated French watchmaker, A. Buisson, published, in the *Revue Chronométrique*, the following very truthful remarks on the inestimable value of theoretic education to the practical watchmaker. His observations should be more especially heeded to-day, when the horologist is offered facilities by professional publications and horological schools to acquire the much wanted information.

Buisson said as follows :

"The majority of watchmakers see in a watch nothing else than what the public at large perceives in it, to wit, the minuteness of the mechanism and the great difficulty and patience to make it; these watchmakers are tickled with the idea that they are able to make these barely visible parts of machinery, and seek their greatest glory in this capacity; they actually possess no higher aim than by the expenditure of patience, skillfulness, and experience to turn almost invisibly small pivots, to polish diminutive wheels to such a brightness that their surface rivals the purest glass, etc. And yet with what contempt, and one might almost say, with what commiseration, these masters regard those who, with their auxiliary tools and utensils, are not able to produce as perfect work as they! 'Well,' say these masters, 'of what good is theory to me? I cannot use it to mount a scape wheel or to divide a pivot hole, or to file well, or to polish—in fact, to set a watch in motion. I find theory superfluous.'

"It is true, practice is of the utmost importance in watchmaking, and has to contend with difficulties of a magnitude almost greater than can be imagined. But, nevertheless, it should not be regarded as the sole requisite of a watchmaker. Is perhaps the mason, practically considered very skillful in his calling, higher than the architect?

"To be a watchmaker in the true and best sense of the word, he must unconditionally both possess and know how to apply theoretical knowledge; we may safely assert that of this consists the calling, and he who is not capable of complying with these two indispensable requisites is no watchmaker of the nineteenth century; nor should he engage to teach young men.

"Yet, this is a thing of daily occurrence. Even if the master seriously strives to instruct his apprentice, how is it possible that he impart to him that thorough elementary knowledge, which he himself does not possess? He may be a good workman, but not a man who possesses theory. Both genius and knowledge are expected of a teacher, and these two qualities may with equal right be demanded of a master, and if our employing watchmakers were to comply with these demands, all ignorance among us would soon disappear.

"Therefore, all honor to those men who, by founding horological schools and delivering of lectures on the theory of the art of horology, endeavor to introduce the young watchmaker into the domain of science. Because, to-day, when everybody seeks to progress, the watchmaker alone must not remain behind. He must not alone pos-

sess the capacity to do, but also the knowledge why it is done. The light which emanates from science, should also illumine the workshop of the watchmaker. My dear colleagues, let us not close our eyes to this fact; let us forsake the road of our present ignorance, and choose that path which tends to information in the natural sciences, not alone in the study, but also in the atelier. And, above all, let us not deem this end in view as one to be attained only with difficulty."

Letting Down Anchor and Cylinder Scape Wheels.

THE FOLLOWING is a very rapid and safe method for letting down an anchor or cylinder scape wheel, without endangering the tooth points. Take a piece of brass pin wire, about 6 cm. long, file it tapering, removing about one half all round, so that the wheel stands in the middle of the wire. Hold the thick end into a gas, alcohol, or other flame until red hot, and the central portion of the wheel is thereby let down in fifteen seconds. The blue spot is easily removed with white muriatic acid, applied with a pegwood, after which the wheel is quickly laid in alcohol, dried in a few seconds, left for a few minutes in oil, to prevent rusting, and finally it is plunged into benzine, to free it from oil.

Views of Correspondents.

This department of THE CIRCULAR is open for communications relating to the jewelry trade, but the editor does not hold himself responsible for the sentiments expressed by contributors. We invite correspondence, but require that it shall be free from all personalities, and the writer's integrity guaranteed by the disclosure of his true name to the editor. Anonymous communications will not be noticed.

RETAIL DEALERS AND OUTSIDERS.

To the Editor of the Jewelers' Circular:

I have been reading your recent editorials regarding the difficulties of the retail dealers, with much interest and pleasure. I do not know as I can write much to assist you in any plan for the bettering of the trade—to which I belong. I think when the watchmaker has the ability and cash at command, it is a good idea for him to add to his stock some other goods, as his taste may prefer, stationery or fancy goods, for instance. But on the other hand we must remember that a watchmaker, after puzzling his brain over some "old hard head," is not in the most suitable state of mind to show off goods in his own line to the best advantage, much less to spend his time selling five cents worth of paper or knick-knacks of some kind. One advantage in your suggestion is that it might cause some dry goods dealer to abandon the jewelry trade to the legitimate dealers. I will cite the following as a case to the point, although in another branch of business: There are two restaurants in our town, both of which formerly kept bread for sale, bought from a bakery in a neighboring town. Some years ago there came a practical baker here, fitted up an oven and all of the fixtures for a first-class bakery. But the keepers of the restaurants continued to buy bread from the other baker and sell it just as they had formerly done when there was no baker here. In fact they favored each other and their own baker, in order to break down the new man, which they finally succeeded in doing. But last spring, another baker came here, but when he started he said to the keepers of the restaurants, "If you continue to sell bread, I will make and sell ice cream, etc." Rather than have another restaurant started, they concluded to quit selling bread, and the new baker now has all the trade and is doing well. Thus I think the retail jeweler, if he would show some spunk, might help to drive the enemy out of the camp. I think they ought to show more business in keeping a full stock, as no doubt they have often given wide awake merchants a chance to sell jewelry on account of not keeping

a good assortment themselves. Another mistake is buying on long credit. I have done that myself, but find it does not pay; buy for cash, get the best terms, sell on a fair profit, and change stock often; is better than large profits, slow sales, and four months' time.

I have not come to the point that is my main object of writing yet; but just here I would like to say that we, as jewelers, who value our reputation as such, should be very careful, and not buy of every Tom, Dick and Harry that comes along and asks you "Shust to look ad his samples a leedle," and then oftentimes to get rid of him order $\frac{1}{6}$ dozen of this, or $\frac{1}{3}$ of that, or $\frac{1}{2}$ of something else, and by the time he has looked over the samples has bought a bill that is a continual source of worriment to him to know how to spare the money to pay for them, from his other part of the stock when the long credit is out. Well, if they are salable goods and as represented, he may get through, but there's the rub. I, for one, vote four months' time and jewelry drummers a first-class nuisance that the trade ought in some way to eradicate. If it did not suit the jeweler to go to a wholesale dealer, and wanted some goods such as chains or sleeve buttons, let him send to two or three reliable dealers for a small lot on three or five days selection. He can get the different goods, compare quality and style, keep what he wants, and return the rest at very little expense, and make a satisfactory selection without having Moses or Solomon (both wise and good men) for counselors. But the suggestion that I wish to call your attention to is this: Let all the practical retail jewelers of the United States form themselves into a Co-operative Manufacturing Company for making first-class plated jewelry, (could be started at first to make a certain line, and increased as time and sales developed.) Make say \$50 the par value of one share, and each jeweler could take one or more shares as it suited. Let that company sell only to its stockholders, who must all be practical workmen. The company to be under control of efficient and practical workmen, consisting of President, Vice-President, Secretary, Treasurer, and Board of Directors, all elected annually by vote of stockholders. Just here I would say the different State Associations might be used to an advantage, as they have not as yet seemed to answer any purpose of their creation. They might be used as State Conventions, so that jewelers of each State could ventilate their ideas, and by means of representatives elected from each association, make their wants and wishes known as to the styles and quality of jewelry wanted by the wearer. Let the Manufacturing Company have a trade mark or stamp, or both, and have all the cards and tags used by them for jewelry and the jewelry itself, when practicable, stamped with that trade mark or stamp. Let there be a duplicate card or tag describing the style, quality, number, and guarantee of all the goods sold, and when the retailers sell these goods, let the customer mail this to the Secretary of the company immediately, and then, if the goods do not wear as he thinks they should, let them be sent to the Secretary, who will examine and make them satisfactory to the purchaser. But some may say the purchaser will not go to this trouble; all right if he does not, but it will certainly beget the confidence of the people in that make of jewelry. I think if all the retail jewelers would join together in this kind of a company that they could do more towards restoring the trade to its proper channel than the State Associations have done or ever will do at their present way of working.

I could write more on this subject, but will not until I hear from you. Most respectfully yours, etc.

E. K. B., Watchmaker and Jeweler.

Hair Springing.

Continued from page 189.

DIFFICULTY is often experienced by workmen in removing the hair spring stud of a Swiss watch from the cock when the cylinder requires cleaning, or any alteration is needed to its parts. I always remove the collet and spring from a watch when I clean it,

and do it as follows: I turn the curb round so that the spring will pass freely out, then holding the cock in the left hand, letting the cylinder hang freely down by the spring, with a fine pair of nippers take a firm hold of the stud close to the cock, and, without any wriggling, but a little leverage against the cock, withdraw the stud straight from the hole. I do not like or advocate unpinning the hair spring from the stud, because the position of it is invariably altered thereby. To replace the stud, when all is ready, lay the cock bottom upwards, place the cylinder in position, the spring in the pins, the stud in the hole, and press home with a screw-driver inserted in the notch. A notch is generally cut in the stud, and this enables a firm hold to be maintained, and serves the purpose of twisting about to get the spring correctly set. I am presuming that the spring and collet have not been detached from the cylinder. When it has, it must first be affixed to it by placing the cylinder in a stake and pressing the collet on its boss as before.

So many watches stop through being out of beat that, although slightly foreign to the subject of hair springing, I think a few remarks upon it in this article may not be out of place, seeing that the hair spring of a watch is often shifted to correct an irregular beat.

In setting a lever watch on beat, an imaginary line should be determined by the eye from the staff pivot and ruby pin to the edge of the balance, and a tiny spot of oil should be placed where the line intersects it. This spot, which can be moved afterwards, should rest exactly over the pallet's hole, when the staff, etc. are placed in position. Another way is to imagine the line from the pivot, over the ruby pin and along a bar of the balance. When this bar is placed exactly over the pallet's hole, and the roller is set accordingly, the beat will be correct. Verge watches are set on beat by placing the thumb on the contrate wheel and pressing it forward in the usual way. This causes the balance to move to and fro.

Notice where a particular bar, or spot, or banking pin rests when there is no motion; then press on the wheel, and observe how far the part noted moves, and mark off the degrees of run; now press the wheel on again, and observe the run to the other side, and mark off. Should the first-made mark be exactly central between the outer ones, the beat is correct. The hair spring should be altered until the run is equal, if otherwise. In Swiss watches, where the original cylinder is present, the escapement marks upon the plate and balance wheel are always to be relied upon—not always after a *new* cylinder has been put in, in consequence of its not being correctly set to the old position. On the edge of the balance wheel a dot will be found, and on the plate, near the escapement holes, three small dots will be found. The dot on the balance should rest exactly over the central dot of the three, and, if not so, the collet should be shifted about until it is. Do not unpin the spring from the stud for this little piece of work, or the timing will be upset. To put the watch on beat when the dots are no guide, if the cylinder jewel hole, the cock screw hole, and the escape wheel jewel hole are set in a direct line, then the pinning-up stud should be on an imaginary line drawn from the edges of the balance wheel, and that will insure a correct beat. If the scape wheel hole lies a little to the left or right of the cylinder and cock screw holes, then the hair spring stud should be correspondingly moved one way or the other, and a correct beat would result. It is somewhat difficult to make this thoroughly comprehensible by written instructions, but as I have followed the plan for years, and get an almost infallibly correct beat by it, I have spoken of it here.

I omitted to mention that a simple tool has been devised for the purpose of removing the hair spring stud from the cock, which does its work in a very effectual manner. As will be seen, it is simply an ordinary stout pair of tweezers, with the extreme points removed, and a pointed screw or plug fixed into one, and a slot cut in the other, sufficiently wide to clear the hair spring stud when passed underneath the cock. The pointed screw or plug is pressed on the end of the stud, and so forces it out easily. If the hair spring curb has been turned to free the spring, and all is held near to the board, the cylinder will fall lightly and safely on it.

When hair springs get very dirty, or, as is frequently the case, have a liberal application of "hair" oil or paraffine (for this is no uncommon thing), by the wearer, the best way to clean them is to lay the cylinder and spring, just as it is, in rectified benzine. The cylinder, in such cases, is almost sure to have a lot of oil upon it. If the cylinder is clean, then, of course, remove the spring on the collet. When in the benzine bath the parts should be agitated a little. After removal absorb, with a piece of blotting paper, as much of the liquid adhering to it as possible, then allow the remainder to evaporate, which it quickly does. The spring, etc. will now be perfectly clean and bright, and needs no further attention. Good rectified benzine is perfectly harmless to the most delicate steel work, and leaves no film on the metal. Common spirit is apt to do this, so should not be used. Benzine should not be used near to a light, as it gives off a highly inflammable vapor, which might prove disastrous if it caught fire. If a small, wide-mouthed pomade bottle, with a closely-fitting cork, to which has been attached a metal hook, be used for this purpose, the various parts may be attached to it, immersed and removed with a minimum of waste and smell, as regards the benzine, and a certainty of the dirt and oil speedily removed.

One frequently needs to weaken hair springs, when a new one cannot be fitted in for some cause, such as not being on hand, and the existing ones are too short or too strong. There are several ways to do this. One or two have already been recommended in this journal. First, we have the acid process, where weak nitric acid is used. The spring is immersed for two, three, or more seconds, according to the degree of weakening required, and immediately on withdrawal placed in spirits of wine to free it from the acid. After a little shaking about in the spirit lay it upon clean blotting paper, and press a portion upon it to absorb the moisture. Another method is to rub down on Arkansas stone with oil. Sometimes a piece of smooth cork is used to press the spring down and move it about, but the end of the middle finger is the most appropriate way by far, as a more even pressure can be maintained. The pressure should be light and equal over the spring, and it should be moved in a circular manner, care being taken that the spring is kept well under the finger, else it may get bent or broken. Another method to weaken them is by heat. In this case the metal being softened down becomes less rigid. A pair of hair spring tongs are required, or, lacking those, a piece of clean metal and a piece of glass. The tongs are held above a very small gas flame, when in use. The top part is held down on the spring with a gentle pressure, and, being perforated, the changing color of the spring may be observed. When the metal plate and the glass are used the spring is covered by the piece of glass, which keeps it flat, and, as in the case of the perforated portion of the tongs, allows the change of colors to be seen. If this process is adopted first, and is not found to weaken the spring sufficiently, then one of the former methods must be adopted. There are workmen who would never attempt the weakening of a spring by any of these methods, preferring rather to put a new spring in at once, and where a good stock of springs are on hand the putting in of a new one is undoubtedly the best. When a hair spring is rubbed down in the manner described its underside is to be kept down on the stone, because the color is removed by the process. Of course the spring is to be removed from the collet and stud in either case.

A few words about the management of the spare piece. Oftentimes, through inadvertence or carelessness, the loose end of the spring is not kept parallel to the acting part, or is not kept free of the expanding coils. In one case it may interfere with the free action of the balance, by touching its bars; or in the other, by retarding the swell of the spring, cause the watch to gain time. I frequently come across watches having these faults, which defy all the owner's attempts at regulating. The spare piece, therefore, should receive close attention, and, when the watch has been got to time, should not exceed more than a quarter of the circumference of the spring in length. It should be accommodated under the cock, and not left sticking out at its side. If left so, the wearer may some day discover it, and, fancy-

ing the spring to be broken, get pulling it about, and thereby do mischief.

There are a few little generalities in connection with hair springs which may be appended to the foregoing remarks, and they will serve to explain what may be ambiguous to some watchmakers, such as the terms "under-springing," "over-springing," "over-coiling," "synchronizing," etc. When the spring is attached to the balance, as in verge watches, that is, underneath the wheel, it is called "under-springing." When placed above the wheel, as in Swiss watches, it is called "over-springing." Both of these methods are common in lever watches, being attached either to a stud in the plate or a bar screwed to the plate and passing above the balance wheel.

The "over-coil" or Bréguet spring differs from the ordinary spring only in the fact that a portion of the outer coil is bent upward, and then returned to about half the diameter of the under coil, and there engages with the regulator in a small circle, the regulator, of course, being much shorter than it would be with an ordinary spring. Several advantages are claimed for the "over-coil" spring, not the least being that where the center wheel is arranged above the barrel the hair spring is free to play under it, and space is thus economized.

The chronometer or cylindrical spring is, I may say, uncommon, as it is never applied to any but the very highest class of work, and to ships' chronometers, consequently it comes but seldom under the notice of a very large proportion of watch repairers. The coils in these springs are all of the same size, and instead of being flat, as in the ordinary spring, are arranged in a tubular form, one above the other. A vast deal more depth is required for such springs, wherefore they cannot be used for small thin watches.

By "synchronizing" is meant such an adjustment of the hair spring that no variation from true time results from the changing conditions to which all watches and many clocks are exposed. It is not my purpose to go into an elaborate exposition of these various terms, so I will leave them with these few remarks.

The hair spring of a watch has often been instanced as an example of the extraordinary increase in market value which attaches to a simple metal, when changed from the rough to a finished state. A pound of steel will cost only a few cents, while a pound of hair springs, of superior make, which after all are only steel converted into another form, will cost from \$1,800 to \$2,000. It seems almost incredible that such an increase in value could arise from the simple fact of the metal being converted into another form, without the addition of anything but skilled labor; it is, nevertheless, the truth. With these statements I will now close my remarks upon hair springs, etc.

COLORING COMMON GOLD ARTICLES.—The ordinary process of coloring, by plunging the articles into a mixture of salt, saltpeter and muriatic acid, is well known. This mixture, which has an energetic corrosive action, dissolves the alloy on the surface and exposes the fine gold in its natural color. This operation, very simple with 18 karat articles, becomes difficult and delicate with those of 12 and 9 karats. The alloy is attacked too strongly, the surface injured, and if the article is thin, even holes are likely to result. To avoid these inconveniences, the following process is adopted: First plunge the articles in a solution of 50 grains of nitrate of mercury in 10 quarts of water, adding 50 grains of sulphuric acid. The articles are thus covered with a layer of metallic mercury, which causes them to appear silvered. After washing in water they are plunged in a bath composed as follows: First dissolve 800 grains of phosphate of soda in 9 quarts of water, and add 10 grains of concentrated prussic acid; secondly, 15 grains of chloride of gold in 1 quart water. Mix the two liquids, and when using heat it to 60° C. (140° F.) The layer of mercury taken in the first bath will be replaced by a layer of gold having the appearance of fine gold. If not sufficiently bright the first time, replunge in the mercury bath, and afterward in the gold one, until the desired effect is obtained.

State Societies.

ABOUT July 8th we received a formal notice, with a request to notice the fact, that the annual meeting of the Wisconsin Retail Jewelers' Protective Association would be held at the Plankinton House, Milwaukee, July 11. It is to be presumed that the members of the association received their notices at the same time, which was, of course, wholly insufficient. The officers had a year in which to make their arrangements for the meeting, but seem to have put it off till the eleventh hour of almost the last day, which is thoroughly characteristic of the management of most of these state associations. Never do to-day what can be put off till day after to-morrow is evidently their motto. Had the notice been issued in proper season, we should have been pleased to have called attention to this meeting in our July issue. Notwithstanding the fact that the notice is about a foot and a half long, it failed to arouse the enthusiasm of the retail dealers, and when the meeting was called to order, it was found there was not a quorum present. Of course no business was transacted, and it would now be in order for the secretary to inscribe over the remains of the association, "Died for want of proper nursing.—*Requiescat in pace.*"

A new state association has been organized in Ohio. The first meeting was held June 26, and the following officers elected: S. C. Session, President; Mr. Luce and Mr. Lynch, Vice-Presidents; W. A. Arnold, Secretary; Mr. Decker, Treasurer. All retail jewelers are invited to become members.

The Cylinder Escapement.

[BY HERMAN SIEVERT.]

Continued from Page 184.

THE SEALING WAX in the cylinder is removed by boiling in alcohol; should this become ignited by accident, hold the vessel with its mouth below against the table-leaf. The flame is immediately extinguished upon the exclusion of air. After a little boiling take out the article, and with the pegwood remove any adhering pieces of lack; then dip a brush into the still hot alcohol and clean the article completely.

REPLACING PLUGS.

If a pivot of an otherwise still serviceable cylinder is broken, it may be replaced. The old plug is beaten out in the manner shown in fig. 24. Drill a hole large enough to accommodate the arbor into

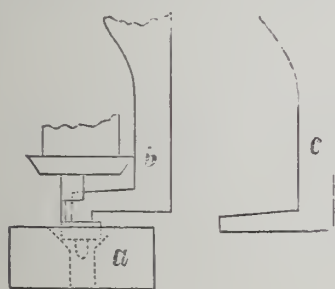

FIG. 24.

a piece of brass *a*, to be fastened into the vice. Open the hole at one end by means of a tapering chamferer, so that only the edge of the tube stands upon the metal when the cylinder is inserted. The plug is now sufficiently driven out by means of knee punch *b*, that it protrudes a little. Then place it into a hole of a steel riveting tool, one in which it fits hardly, so that the tube is well supported all the way around. Should the first knee punch not suffice, take a second one with longer pivot and drive out the plug completely. It happens sometimes that the upper one sits so firm that it cannot be budged; in this case drive the cylinder out of the brass collet and try again. Should it not yet move, slightly hammer the outer side of the large tube all round, especially near its end, using a smooth anvil as underlay. The plug can now be driven out if it has not been soldered in by some botch, as has happened already to the author.

The material for the plugs, good round steel, is carefully to be tempered and annealed by blazing off with oil upon the blueing plate. As soon as the oil ignites, remove it from the lamp and extin-

guish it before it is entirely consumed. A sufficient hardness of the steel is necessary for fine watches. Turn the plug in the shape shown in fig. 25, only slightly tapering, so that when inserted it does



FIG. 25.

not fit all at once. The small plug must enter from two-thirds to three-fourths, the large one from four-fifths to five-sixths the length of the tube when pressed in by the hand. Then turn the remaining part of the form; *a a* are centers used for turning, *b b* the future arbors. It is better to turn on the large plug obliquely, so that this part may brace itself in the conical hole when turning on the point, since it may be possible that the brass collet of the old cylinder is untrue, in consequence of an eccentric pivot. The arbor of the small plug, however, may be turned on at right angles, since the tube itself decides the setting round of the cylinder. When a plug has been turned nearly sufficiently far, file off the centers used for turning, polish the face in a screwhead polishing tool, or in any other appropriate manner, and beat it in solid. The remaining work is similar to turning in a new cylinder.

It is impermissible to use the old upper plug after it has been driven out somewhat for making a new pivot, since a hollow is hereby created in the large tube in which the oil collects.

The knee punch *c* (fig. 24), serves for driving in the plug by inserting the arbor of the latter into a suitable hole of the riveting tool. The lower piece of the punch must be sufficiently broad to cover the entire free face of the tube, and thin enough to enter freely into the small cut.

MAKING A NEW CYLINDER.

Although good cylinders of every dimension may at present be had at a low price in commerce, still, the repairing watchmaker should learn to make one himself, if for nothing else than practice. Cases may occur when his ability in this direction may be of service.

Very good round steel has to be used for a new cylinder, a little thicker than the latter is to be; best of all is the finest English square steel, on account of its very close grain. Heat it to dark heat to facilitate working it, and let it cool off slowly in hot ashes. With a carefully made drill, a little smaller than the length of the scape wheel tooth, lengthwise drill in a hole in the turning lathe and turn the thus produced tube of suitable size. The length of the tube is equal to the entire length of the cylinder, after deducting the arbors and pivots, but for sake of precaution, the tube is to be left a little longer. Now cement the tube in the hole of a small brass chuck; it might be pressed flat by fastening in, whereby the cylinder would not become true and round. With a very sharp and tapering broach open the hole a little from both sides until the scape wheel tooth enters freely, but without shake. The necessary quantity of shake will result from grinding and polishing. Then place the tube upon a straight steel wire that enters with a trifling shake, fasten the wire in a piercing-saw frame, and place a little oil and oilstone powder on it. Now roll the tube with the small brass chuck upon the palm of the hand, at the same time draw the tube a little to and fro. This is to be continued until all marks and strokes are obliterated from the inside of the tube. Then take it out of the cement, clean, and turn it cylindrical upon a smooth, true and very little tapering turning arbor, until it passes without shake through point and heel of two teeth. Next grind it in the lathe with an iron file, or, what is still better, in an ordinary depthing tool by means of the disc. Every depthing tool, even a small one, may be used for this purpose, a piece of brass is screwed to it for fastening.

Should the tube wall be too thick, it is owing to the insufficient length of the scape wheel tooth. Since an unduly thick cylinder gives a bad rate, another tube must be made in case the hole cannot be widened.

Then make the cuts with a good square file. Better, however, is

the cutting of the tube with two fraises in a depthing tool. In either case a well hardened turned brass wire is to be truly fitted into the tube. The first fraise must be of the breadth of the entire cut, and five twelfths of the cylinder's diameter are to be removed therewith, so that the full portion be about seven-twelfths, or, exactly 57 to 58 of 100 parts of the diameter. You must also bear in mind that still another small loss ensues when grinding and polishing the lips, and a trifle more had better be left standing. Then make a suitable fraise for the small cut in this instance, leaving only the one-fourth part of the cylinder wall standing. You know that the height of the cuts is regulated by the thickness of the cylinder wheel, the height of the large cut is not to be more than actually necessary for the free motion of the wheel, so that the oil sink in the upper corner within the cylinder may lubricate the friction upon repose.

If the cuts are to be filed in, two files are necessary, with sides ground off to prevent the end faces from attacking the tube, they must also be of the exact breadth of the cuts. The two tube faces are afterward to be set in order with a fine barret file and their corners made angular.

When taking down the cylinder from the brass wire, have a care not to bend the former. For this purpose, press with some sharp-cornered tool against the full part of the cylinder. The preparing of the lips follows next, their conformations are known to you, but they must be made with the greatest care and exactness. A fine square file is used for this with smooth sides, and, so as not to injure the interior of the cylinder, when working the small lip, the point is ground obliquely. While filing the lips keep the cylinder upon a brass wire pushed into the tube, but let it not project. When both lips have been finished with the file, remove the burr first with the aid of the wire fastened into the piercing-saw frame, and next smooth by grinding the lips with a suitable file.

To prevent the cylinder from drawing out of shape when hardening it, place it into a brass tube, the ends of which can be filled with charcoal to prevent the admission of air. Then observe the heat, do not raise it beyond cherry red. Perform this hardening in a dark corner so as not to be deceived by the light of day. The cylinder must now be glass hard and is very fragile in this condition. Grind it white, but be very cautious, and then anneal it on both ends after it has been cleaned in benzine. Into each hole, but no farther, insert a rather tightly-fitting brass wire of about 15 mm. in length. The operating part of the cylinder must remain entirely hard, therefore seize it with a tweezers just covering the lips and heat the brass wire until the tube colors gray-blue. When both tubes have been colored, grind and polish the lips with an iron or composition file.

The finishing touches of grinding and polishing of the inner surface of the cut in cylinder must not be done in the previously described manner, but turn the tube only half round and guide it to and fro, without letting the grinding wire leave the inner repose. The cylinder would not remain round without this precaution, but become thinner near the open side. Take only coarser red this time for grinding, and use finer for polishing, but the cylinder must be washed clean every time.

The polishing of the outer face is at all odds done best by aid of the iron and composition disc in the depthing tool, as the cylinder remains round, in case you employ a true-running turning arbor.

After the cylinder has been polished well both inside and out, the plugs are turned in, which work is already known to you. If the cylinder is placed round upon its centers by aid of the tapering holes, turn the large tube a little tapering above so as to mount the brass collet upon it. It is turned first nearly conformable in shape upon a turning arbor.

SETTING THE JEWEL HOLES.

Although there are a number of more or less practical utensils for making the jewel settings, still they can only be considered simple makeshifts. He who possesses a universal turning tool with fixed cutter will, with a little practice, be able to set jewels in a very superior manner.

To judge of the correct measure of the sinkings to be made in this work occasions a little difficulty; the strongly lustrous appearance of the turned brass deceives the eye, especially with such minute proportions, and too wide or too deep a sinking, in the majority of cases, makes the setting useless. Let us therefore cast about for mechanical auxiliaries for measuring jewel settings. By the majority of the newer universal tools, the two screws serving for moving the cutter to one side, and forward and back, are provided with small index plates, the circumference of which is generally divided into twelve equal parts. These parts truly indicate the quantum of the cutter's motion. It is to be deplored that this measure is not yet in conformity with the metric measure. It becomes necessary, therefore, to manufacture a special gauge whereby we take the distance accomplished by one revolution of the screw as unit. Now take a brass ruler sufficiently thin to be inserted between the side bearers of the upper slide and its support. The upper slide moves by power of the screw in a direction vertical to the place of the clamp head. In the same direction now hold the ruler firm upon the support, bracing the fore end against the clamp head. Next place the index plate upon a certain point, and by means of a sharp point mark a line upon the ruler close at the fore end of the slide. Then turn the screw very exactly once around and again make a line, and so continue doing until you have about 30 or 40 strokes upon the ruler. Since the other screw for the parallel motion of the cutter is provided with the same thread, optionally large and deep sinkings may be made by help of this ruler without paying attention to anything else than to the number of revolutions of the index plate, above which a small index hand is screwed for exactly indicating the twelfth parts, or in whatever other manner the dial is divided. It is self-evident that the ruler, similar to any other gauge, must close with a full unit. It would be of an essential advantage if you were to construct this ruler gauge into a vernier (finely graduated slide) similar to the millimeter sliding gauge, wherewith to measure the fractional parts of the revolution of a screw. Considering the smallness of the jewel settings, above unit of measure is of decided magnitude, and, consequently, the employment of a subdivided scale is highly necessary.

Thanks to an accidental development in the arrangement of many universal tools, we possess a still better means for measuring the cutter motion. While remeasuring the division upon said ruler I ascertained that seven revolutions of the screw were equal to one motion of the cutter, which is a small trifle less than 5 mm., but a little more than 4.9 mm. Since so small a difference is of no moment, I had, consequently, $\frac{1}{7}$ mm. cutter motion to 1 revolution of the screws, and accordingly divided my index plate into 7 parts instead of 12, so that each degree of the index plate is equal to $\frac{1}{4}$ mm. cutter motion. This resulted in the advantage that jewel hole, thickness of metal, etc., may be measured with the decimal measure. Since, perhaps, not all turning tools can in this manner be arranged for the use of the metric gauge, the previous statements refer simply to the ruler and the dowzieme (twelfths) division of the dials.

After this deviation, let us engage our attention in the preparation of jewel settings, one of which is represented in fig. 26, ready for

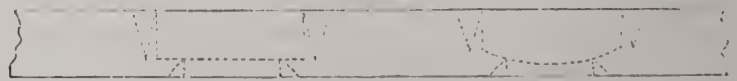

FIG. 26.

FIG. 27.

the reception of the jewel hole. A small hole must be drilled first at the place where the jewel hole is intended to be located. By this hole center the article truly upon the lathe and open it somewhat with cutter No. 5 (fig. 28). Previously, however, place the cutter exactly of the same height with the centering point and mark the position of the index plate on the side, or, in case it is movable upon the screw, put it to 0, when the cutting face on the side of the cutter stands truly in the center, according to the centering point.

Next measure the jewel to be set; supposing the index plate of the tool be divided in 12 parts, and the jewel measure $\frac{1}{4}$ in diame-

ter and $\frac{1}{2}$ in thickness. The diameter must be taken rather full, as the jewel must not pinch in the setting, and we add still $\frac{1}{2}$ to the thickness of the jewel hole for the smoothing down of the setting, whereby we obtain $\frac{6}{2}$ for the depth. Now, in order to make the sink, place the cutter by the radius of the jewel, $\frac{7}{2}$, eccentric, cause the cutter to advance slowly until it takes hold, and let it enter $\frac{6}{2}$. Then let the cut go again to the center and the sink is ready. So as to see whether you have measured correctly, place the jewel hole upon a pegwood and fit it in. If the size is correct, turn the cut in with a sharp cutter, so that the burr remaining standing is as thin as possible, it will fold so much the better to the jewel.

It is by no means so easy a matter to turn in the cut so that the burr remaining standing retains exactly its correct thickness. Let me therefore recommend to you the following process:

For the whole work of jewel setting, a cutter is used as represented in No. 1 (fig. 28), only it is ground still more acute, and, moreover, the wall of the sink must be made with the straight face. The

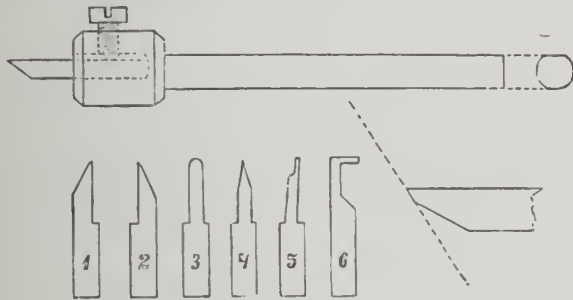

FIG. 28.

breadth of the latter is now exactly measured at the place, so far distant from its point, as the depth of the cutter is to be. When the sink for the jewel hole is ready, and the cutter stands against its side, it is screwed back sufficiently, until cleared. The cutter now is again brought farther by the measure of its breadth, and then screwed forward for turning out the cut. The burr will become thin and sharp in this manner, without incurring the risk of turning it out altogether.

The folding down of the burr is also performed in the tool. Place the jewel, secured upon a pegwood, into the sink, and raise the tool up high, somewhat slanting, if you fear the falling out of the jewel. By means of the hand rest and a polished point then press down the setting, while continually turning, and make it conform closely to the jewel. Superfluous portions may easily be turned away with the hand cutter in the left hand, until the setting looks clear and handsome. Then reverse the object in the lathe, and lay the jewel clear from the other side by means of a hand cutter, somewhat rounded off.

Fig. 27 is a setting for a jewel with rounded face; the cutter used for this must be ground accordingly.

When a jewel hole is concerned, which is to be uprighted by another one already inserted, use the process previously specified for uprighting the center wheel. Open the hole a little by turning, truly center the opposite hole. If the jewel is to be set from the inside, the bridge upon it is to be unscrewed, and the object reversed in the tool. In an opposite case, the setting may at once be finished; for instance, in the scape wheel bridge, the jewel setting of which may both be turned outward or within, according to the shape of the jewel hole. The uprighting of the wheel is better secured hereby, than if the bridge is taken down and cemented. It is self understood that weak bridges are to be supported by wood underlays upon the plate.

An old setting, in which a useless jewel is to be replaced, can, with a little care, be reopened with a small instrument, to be had in material stores, although it can also be done with a polished point in the tool. A ruined setting is to be secured with a rather large bouchon, and made new. Special care is necessary for this work in case of a very weak bridge; for instance, the scape wheel bridge, with its two screw holes for the regulator screws. This bridge would hardly bare

the riveting of a large bouchon at this place. Moreover, since conditions here are different, and the jewel must be located as near below the upper face of the bridge as possible, I wish to explain the manner of doing this work.

First, chamfer out the entire useless setting, and fit in a good, round piece of brass; it may protrude a little upon both sides. The weak bridge, as well as the necessity of fastening in securely the bouchon, force us to employ soldering. After the bridge has been cleansed in benzine of all oil and dirt, moisten the edges of the bouchon upon both sides with a little soldering fluid, lay a very small piece of pure tin close to it, and hold the whole high above the flame. The tin will then quickly and equally fill the points. But do not take too much tin, to prevent it from running too far. Then screw the bridge, after having washed off the acid with alcohol, firmly upon the plate, lay a piece of wood as support below, and fasten the plate in the lathe, carefully inserting the centering point into the lower jewel hole. Then turn the bouchon smooth, but for sake of precaution, still let it protrude somewhat. Next mark the center as nearly as you can, and drill a small hole through. To upright the hole perfectly true, turn it again a little, to about the necessary size; a very small jewel is to be employed, however, on account of the bouchon, and the hole must not be made too large. Now take down the whole from the tool, and unscrew the bridge, as the jewel must be set from within. Two clamps suffice for fastening, and you can fasten the bridge direct in two clamps; or you may cement it upon a level turned surface, in such a manner that both bouchons, also that left for the balance spring stud, remain free; the jewel hole would otherwise not sit straight. But previous to this, you have ascertained the thickness of the bridge (without the protruding bouchon), according to the turning tool gauge, say, at about seven-twelfths. You now know that you may cut in five to six-twelfths without coming in contact with the setting above the bridge. If a new bridge were concerned, you might leave more standing, and file the bridge thinner afterward, so that the jewel be located sufficiently close under the surface. But here you must ascertain the depth of the setting with great exactness, since the bridge is gilt, consequently a future correction is not permissible. First, therefore, after the hole in the bridge is carefully centered, turn the bouchon even with the inner bridge face, and then cut in the sink for the jewel from five to six-twelfths deep. When the jewel has been mounted in the described manner, take the bridge down from the tool, and fasten it again upon the watch plate, as previously, so as to turn the bouchon, still protruding somewhat, as level with the gilt face of the bridge as the position of the jewel will permit. If the work is executed in a careful manner, not much can be seen of the disagreeable tin soldering. The jewel hole cannot be turned free, on account of the cap jewel.

The replacing of a damaged jewel hole by a brass bouchon, especially in the parts belonging to the escapement, is a downright injury to the watch, and no decent watchmaker would do it.

It is hoped that the preceding hints will aid you in becoming a skillful watchmaker.

[THE END].

ACCORDING to the *Revue Chronométrique*, there are annually manufactured 2,500,000 watches, and during the last fifty years more than 70,000,000 have been put on the market; there remains yet for us to add a stock of not less than 50,000,000 of old watches, which makes a total of 86,000,000 to 87,000,000 watches requiring glasses. The new watches consume nearly 4,000,000, which makes an annual consumption of not less than 47,000,000 of glasses. But we must add that every watchmaker away from a town sees the necessity of always having on hand an assortment responding to the wants of his customers. Then if we take into account children's watches, lockets, compasses, etc., one finds one's self with astonishment in the face of an annual consumption which cannot be less than 100,000,000 of glasses.

Workshop Notes.

CLEANING SILVER.—To produce a frosted surface upon polished silver use cyanide of potassium with a brush; the silver should not be handled during the process, but held between pieces of boxwood or lancewood. The proportion should be one ounce of cyanide of potassium in one pint of water. But be cautious, since the stuff is very poisonous.

TRANSPARENT CEMENT.—A good transparent cement for fastening watch glasses, etc., in bezels or settings, is made by dissolving 7 parts of clear gum arabic and 3 parts crystalized sugar in distilled water; the bottle containing the mixture should be placed in a utensil of hot water until the mixture assumes the consistency of syrup, and then left well corked for use.

REDUCING DIAMETER OF A WATCH GLASS.—The diameter of a watch glass can be reduced by centering in a lathe, chucking it between two pieces of cork, or a pair of cork arbors, and applying a moistened piece of glass to the edge, or an emery stick. When the desired diameter is attained, polish the edge with pumice stone, followed by putty powder applied on a wet cork.

CLEANING BRONZE.—A very good recipe for cleaning bronze, steel, brass, etc., and one I have used with great success, in cleaning gas holders, troughs, etc., is as follows: Take 1 ounce of oxalic acid, 6 ounces rotten stone, $\frac{1}{2}$ ounce gum arabic in powder, 1 ounce sweet oil, and a sufficient quantity of water to make a paste. Apply a small portion to the article, and polish with a flannel or a piece of soft leather.

ELECTRO BRASS PLATING.—Mr. J. J. Heoz uses the following bath, which differs materially from former formulæ: 84 grains sodium bicarbonate, 54 grains ammonium chloride, and 13 grains potassium cyanide are dissolved in 2 liters of water. To render the bath active, the sides of the vessel are covered with a sheet of brass, which serves as anode, while another piece of brass hangs in the bath and forms the cathode. The current is allowed to pass through the bath for 1 hour, after which it is ready for use. It is better to use cast brass.

TO BROACH A HOLE VERTICALLY.—A hole in a plate, as, for example, that in a barrel, is seldom maintained at right angles to the surface by young watchmakers when they have occasion to employ a broach. By adopting the following method success may be assured. Take a long cork of a diameter rather less than that of the barrel or other object operated upon, and make a hole in the length of the cork through which the broach can be passed. When the cork has been turned quite true on its end and edge, the broach is passed through and used to enlarge the hole, by pressing against the back of the cork it is kept always against the barrel, and the verticality of the broach is thus maintained.

TO STRAIGHTEN A STEEL ROD.—When the rod is short use a large pair of sliding tongs or a hand vise, the jaws of which have been softened in order to make a groove in each parallel to the edge. Placing the rod in the cylindrical recess thus formed between the jaws, fix one side of the hand vise in a bench vise, holding a spirit lamp near the jaws, and as the steel changes its color, tighten the slide or screw of the former. When the metal assumes a blue color, and the jaws are as tight as possible, remove the lamp, allowing the whole to cool slowly or by applying water. The jaws should be formed so as to bend the rod rather more than is ultimately required, because steel, on being released, is apt to partially recover its initial curvature. When the rod is long, grip its two ends in the frame of a fret-saw, which should be somewhat strong. Then hold a lamp under the rod, at the same time stretching the steel more and more, and allow the steel to remain stretched until quite cold. If it has been sufficiently stretched the metal will be rendered perfectly straight.

OXIDIZING SILVER.—Dr. Ellsner says that there are two distinct shades in use; one produced by chloride, which has a brownish tint, and the other by sulphur, which has a bluish-black tint. To produce the former it is only necessary to work the article with a solution of sal-ammoniac; a much more beautiful tint, however, may be obtained by employing a solution composed of equal parts of sulphate of copper and sal-ammoniac in vinegar. The fine black tint may be produced by a slightly warm solution of sulphate of potassium or sodium.

FLATTENING AN ORDINARY BALANCE SPRING.—Remove the collet and stud, and clamp the spring by a central screw between two plates, which are then placed on a blueing tray and gently heated. A small piece of whitened steel is laid on the plate in order to see that the heat does not exceed what is needed to give a blue temper. Allow the plates to cool and separate them. Ordinary springs being made of rolled steel and subsequently coiled, always open out on heating; it is therefore necessary, before resorting to the above method, to coil up the spring, as otherwise the outer turn will be found to have opened beyond the stud.

TO SET A WATCH HAND IN POSITION.—The most delicate part of this operation is the enlarging of the center hole of a minute hand and the closing of the hour hand socket when necessary. Set the hand in cement on a brass plate that has a hole passing through at the point corresponding to the socket. The hole must then be enlarged with a semi-cylindrical drill to a diameter such that it will be necessary to gently pass the broach through afterward. The drill must not be worked too rapidly, and the plate may require to be immersed occasionally in water, so as to avoid heating the cement and thus loosening the hand. When the hole in a watch hand is too large it may generally be sufficiently reduced by means of the tool designed for that purpose.

NEW METHOD OF NICKEL PLATING.—A German periodical describes the following method of nickel plating by immersion: The article to be plated must be free from rust or greasy matter, and the chemicals be pure. Prepare a weak solution of chloride of zinc containing about 5 to 10 per cent. of the salt—say 1 to 2 ounces of the chloride to 98 or 99 ounces of water. To this add enough sulphate of nickel to turn the solution a deep green color; the solution is then heated to the boiling point in a Wedgewood or other porcelain vessel. Next suspend the object in the water for half an hour, when a brilliant white coating will be formed; then wash the article and carefully dry it. Articles thus plated will bear light cleaning with whiting. The solution may then be poured off, filtered, and used again with a small addition of the chloride of zinc and the sulphate of nickel. In like manner, a covering of cobalt may be obtained by using sulphate of cobalt in place of sulphate of nickel. The color of the cobalt is very nearly like that of polished steel, with a slight rose tint, but it does not rust.

TO CUT GLASS.—It is possible to cut a sheet of glass roughly to any required shape with a pair of scissors, if the operation is performed under water. Of course a smooth edge cannot be obtained by such means, but it will often be found sufficient. A more exact method is to use a piece of ignited charcoal or the pencil mentioned below, first making a scratch as a starting point and holding the heated substance a little in advance of the crack; this will follow the direction in which the hot body is moved. The method is available for dividing glass tubes or other objects of irregular shape. The substance is known as "Berzelius pencil," and used for cutting glass. It is composed of the following mixture: Gum arabic, 6 parts; gum tragacanth 2.3 parts; benzoin, 2.3 parts; lampblack, 18 parts; and the requisite quantity of water; mix the gum tragacanth with water, and leave it to swell up for some hours; dissolve the gum arabic in a sufficiency of water, and powder the benzoin finely. Mix the three, forming a paste of such a consistency as to be molded, the lampblack and a little water being also added. The pencils are then formed by rolling between two plates.

Trade Gossip.

Popular scarf pins are plain gold heads or jeweled pins.

The latest designs in fine gold jewelry are taken from the finest examples of Hindu work.

As diamonds are constantly advancing in price, the plumber of the future may be obliged to wear pearls.

Hamilton & Hunt have dissolved partnership. The firm will hereafter be known as Hamilton & Hamilton, Jr.

Downey & Smith, manufacturing jewelers, have dissolved partnership, and William Downey succeeds to the business.

William S. Hedges, of the house of William S. Hedges & Co., diamond importers, is now in Europe purchasing goods for his firm.

Lace pins continue in fashion. Many new and beautiful designs have appeared. Those copied from Hindu works of art are the most sought after.

Henry Irving is said to have 200 pairs of gold and silver mounted suspenders. But what doth it profit a man if he hath 200 suspenders if he loses one button.

Ornamental pins or brooches in fanciful designs are used to fasten the end of the pelerine over the left shoulder, or to attach a bow or bouquet at the same point.

A few years ago everything was made in clusters, brooches, finger and ear rings, but now the solitaires are preferred, with as little gold as possible in the mounting.

A pretty novelty lace pin is in the form of a mandolin in old silver with strings and frets of gold, and a pink enamel ribbon attachment studded with small diamonds.

The "dude" pin continues in public favor. The head of it contains more brains than the average of the type of the *genus homo* that affects it. But it is fashionable, and sells well.

Kossuth Marx & Co. present an unusually large and complete assortment of jewelry of every description. Their new 14 karat gold chain, silver lined, has made a decided hit, and is rapidly growing in favor.

The bankrupt stock of N. M. Shepherd, whose failure was duly announced in these columns some months ago, is now offered for sale by the committee of creditors, and will be sold at a sacrifice to close it out.

Link cuff buttons are rapidly growing in popularity. This is an old style returning again, and bids fair to have a long life. The Windsor Link is the latest agony in this style of goods, and it is deserving of especial mention.

A new watch company has started at Aurora, Ill., with an alleged capital of \$250,000. They are to make a special line of movements for the trade. E. W. Trask, a jeweler of that town, is said to be interested in the company.

Mr. F. O. Lodwick, of the firm of Lodwick & Nolting, has recently returned from Mexico with his health entirely restored. He has been a hard worker for many years, and was much in need of the rest and recreation he enjoyed during his recent trip.

A number of young men connected with various well known houses in the trade have organized the Triton Club, for fishing purposes. Their first annual excursion and dinner took place at Greenwood Lake, July 11, and was a success in every respect.

T. B. Hagstoz, who recently retired from the firm of Hagstoz & Thorpe, has formed a co-partnership with James Burdick, under the firm name of T. B. Hagstoz & Co., and have bought the diamond department of Morgan & Headly, of Philadelphia.

A large number of buyers have been in town recently, and among them we noticed a number of "tin ware" and prize package jewelers, and a liberal sprinkling of outsiders of every description. The way the "box men" are working them is a sight to behold.

It is stated that a new watch company is to be started in Connecticut under the auspices of a well-known clock company of this city. Several gentlemen with abundant means have subscribed to the stock, and it is intended to locate the factory at Thomaston, Conn.

An enterprising assayer of Newark has offered Carter, Sloan & Co. several thousand dollars for the old flooring of their factory, and to replace it with a new one. This floor has not been taken up for years, and it is thought there is at least \$10,000 worth of gold in it.

Robbins & Appleton have discovered that a firm on the continent has been making bogus American watches, using the trade mark of the American Watch Company. Suit has been commenced against the parties, and will be prosecuted with that degree of energy that characterizes all transactions of this firm.

The Olin Chuck Company, formerly of Mason, Michigan, has been reorganized, and is now known as the Olin Watch Tool Company of Piqua, Ohio, to which place the business has been removed. New machinery has been added to the factory, and the company will soon place on the market a new line of tools of every variety.

The Vacheron & Constantin watch has scored a great victory at the Yale observatory, having been awarded the highest average of any watches tested. Their watches were subjected to the severest tests possible, and made a record of 85 points out of a possible 100, which is the highest average ever recorded at this Observatory.

The firm of Hagstoz & Thorpe has been dissolved by the withdrawal of Thomas B. Hagstoz. Mr. Thorpe announces that the firm will hereafter be known as C. N. Thorpe & Co., with Geo. W. Childs as a special partner. He also announces that Edward C. Chappatte and Howard L. Roberts have been admitted to an interest in the business.

The authorities at Washington are determined to suppress the manufacture of coin bangles. The chief of the Secret Service Division of the Treasury has issued instructions to his agents looking to suppressing the manufacture of "bangles" in imitation of gold and silver coins—an industry which is reported to be increasing to a great extent in the West.

Baker, Pratt & Co. carry a large and attractive line of fancy stationery and notions specially adapted for the jewelry trade. Many retail dealers have found it profitable to follow the advice of THE CIRCULAR, and supply themselves with goods of this character. Baker, Pratt & Co. is an old and trustworthy firm, whom we take pleasure in introducing to the trade.

Hirsh Brothers introduce a novel and unique idea in watch cases. It consists in adapting the back cap to contain a photograph, which leaves the picture framed in gold, and covered with a glass if desired. By this means any fellow can have the picture of his particular girl—or any other fellow's girl—nearest to his heart, and convenient for "ready reference," as occasion requires.

A watchmaker, of Camden, Mo., recently found a sparrow's nest in the hay field, and carrying one of the eggs home put it in the clock. Some time afterward it was noticed that the clock, usually a very reliable affair, had stopped. Investigation showed that the egg had hatched inside the clock case, and the pendulum had collided with the infant sparrow. The bird, strange to say, lived and grew.

John Henry French, the well-known and eloquent jewelry auctioneer, whose persuasive arguments and impressive blandishments no one can withstand, has returned from San Francisco to Chicago, his first love (we have forgotten her name). He is ready to treat, on satisfactory terms, for the disposal of the stocks of jewelers who may contemplate retiring from business. He may be addressed at No. 115 Madison street, Chicago.

The great diamond mine in South Africa, which is 380 feet deep and $1\frac{3}{4}$ miles in circumference, has caved in to such an extent that it is estimated that a year and a half will be required to clear it, and the expense £250,000. The mine has yielded £3,000,000 in diamonds in a year, and the collapse is a very disastrous one for the mining companies. Several leading operators have committed suicide in consequence of their financial losses.

The firm of Wheeler, Parsons & Hayes is doing a very satisfactory business, and its transactions are characterized with energy and enterprise. Mr. Monell, the junior partner, is not only an indefatigable worker, but evinces skill and ability in the management of the details of the business. The older members, who have already won their success and business laurels, are inclined to let the junior exhibit his capacity, and thus far he has fully met their expectations.

The jewelry store of Myron Dubois, at Ellenville, N. Y., was entered July 11 by burglars, who pried open the safe with wedges and stole \$5,000 worth of jewelry. Three men who were seen loitering about the village were suspected, and officers started to find them. They came upon the three in a cluster of woods near the village about noon next day. They showed fight, but one who had a revolver placed at his head surrendered, but the other two escaped. A large quantity of the stolen property was found on the man arrested.

The firm of Bowman & Musser, of Lancaster, Pa., have just issued a neat and attractive net price list, which they send sealed to their customers, taking every precaution to prevent its falling into the hands of the public. The principles adopted by the firm in selling strictly to the trade, and refusing to sell retail customers, outsiders or peddlers, has contributed largely to their growing popularity and success, and furnish an excellent illustration of what strict integrity will accomplish.

The annual ruby has been discovered this year in Georgia. It is a little early this season, for it has, for the past ten years, been invariably found between the 15th and 25th of August. It is one of the most peculiar rubies ever known, for it won't stay found, but persists in losing itself, evidently with the fixed purpose of being discovered again the following year. This year's ruby has all the characteristics of its numerous predecessors, and the secular and religious papers are heralding its discovery with effusion.

The fifth annual meeting of the New York Jewelers' Club was held at the Astor House July 10th, and the following officers were elected for the ensuing year: B. W. Ellison, President; S. P. Howard, Vice-President; J. S. Cooley, 2d Vice-President; J. W. Senior, Secretary; J. G. Fuller, Treasurer. The Executive Committee consists of T. L. Parker, R. A. Johnson, Jacob Marks, F. H. Bliss, A. Pinover, W. C. Kimball, J. W. Senior. The annual report presented a very satisfactory showing of the financial condition of the club.

The firm of Morgan & Headly, of Philadelphia, having recently disposed of their diamond department, will hereafter give their exclusive attention to optical goods. All kinds of optical goods are manufactured at their factories, which give employment to nearly two hundred skilled workmen. The firm is well and favorably known in the trade, and as it is now devoted to a single line of goods, these will be pushed with unusual energy and enterprise, while every effort will be made to maintain the standard character of their productions.

Messrs. Kahn, Hanover & Co., importers of scientific instruments, have just published an interesting and admirably arranged catalogue of optical, meteorological, mathematical, engineering and other scientific instruments, and electrical apparatus. The work embraces every department in the above sciences, and presents some 400 well executed illustrations that will prove invaluable to dealers who handle this line of goods. The price list is judiciously concealed in the back part of the work, so that dealers can show the illustrations to their customers without exposing cost prices.

The Vienna police have just arrested Heinrich Nuek, a civil engineer, sometimes calling himself Baron Knoblauch. An Italian count, with whom Nuek had business relations, offered for sale to Vienna jewelers diamonds worth \$100,000, and the police interrogated Nuek on the matter. His answers were satisfactory, but within twenty-four hours the count disappeared from Vienna. Nuek has been watched ever since, and the police are now convinced that he is the real head of the gang of international thieves and swindlers who were the chief actors in the Hatton Garden jewelry robbery.

The taste for colored stones is fast developing. The townnalsines, which come in all colors, are most worn. They are cheaper than the chrysoberyl, which is next to the sapphire in blue stones. Its composition is very like that of the "cat's-eye." It has also various shades of color. The Alexandrites are the most beautiful of these stones. They come from Ceylon, and present the phenomenon of having two shades of color, an olive green by day and a columbine red at night. The emerald is regaining its old-time popularity, and the superstition which has always clung to the opal is being gradually removed, and the sale of this delicate and beautiful gem is increasing. Rubies and diamonds still hold their popularity, and pearls are rapidly increasing in value and repute.

During the past month three burglaries have been committed upon retail dealers, who had no other protection than that afforded by cheap and insecure safes. In one case, the unfortunate dealer was robbed of his entire stock, and in the others valuable goods were taken. Had these dealers been under the protection of the Jewelers' Alliance, they would probably have recovered their goods and captured the thieves. The Alliance offers to provide the best detective service to be obtained, and to spare no effort to recover stolen property. It costs little for dealers to become members of the Alliance, and all of them should hasten to join it. We learn that through the influence of the Alliance a portion of the goods stolen in one of the cases referred to was recovered, although the person robbed was not a member. This is one illustration of what the organization can do, and proof of its value to retail dealers. At a recent meeting of the Executive Committee, fifty-three new members were received into the Alliance. There is room for hundreds more.

An enterprising Chicago house is reported to have adopted an ingenious method of selling goods to the trade and to outsiders at the same time. It is said that they send out two travelers with one trunk between them. One traveler visits the retail trade and arranges to exhibit the contents of the trunk, representing that he is not permitted to sell to any outsiders. When he has worked the trade for all it is worth, the other traveler invites in the outsiders and fills them up from the same trunk. By this means the house referred to is not only enabled to run with the hare, but to hunt with the hounds at the same time.

Henry F. Piaget, one of the oldest watchmakers of this city, died during the past month in the 79th year of his age. Mr. Piaget came to this country from Neufchatel, over fifty years ago, and immediately engaged in business in this city. Some ten years ago, some sneak thieves robbed his place of a large and valuable stock of goods, which seriously unsettled him, and is believed to have been the cause of his aberration of mind during the last few months of his life. He was regarded by the trade as a thoroughly upright and honorable man, who paid his debts promptly. He leaves six sons and one daughter, all of whom are well settled in life.

Special Agent Brackett, of the Treasury Department, thus remarks concerning smuggled jewelry: "The practice of smuggling jewelry from foreign countries into this country through the mails is becoming more and more prevalent with people who seem bent upon defrauding the government, and we are puzzled as to what method we shall take to adequately punish those who are engaged in the business. Of course we can confiscate the goods, but that is not sufficient punishment for the smugglers. A package is found in the mails. It is addressed to a certain person. When we go to the person he says he is not responsible for the act of the party abroad who mailed the package. Thus we cannot prove any guilt on the part of the addressee, and it is useless for us to arrest him." Within a month past nearly a score of packages of jewelry have been captured in the mails.

The death, near Naples, is announced of Senior Alessandro Castellani, of Rome, the distinguished jeweler and antiquarian, in the 59th year of his age. The deceased was the author of several able papers on antique jewelry, and was one of the most eminent men in the jewelry business. He had the finest collection of antique gems, jewelry and bronzes of any private collection known. It has been long supposed by many writers that the art of making granulated shot, found in ancient jewelry, had long been lost, but Senior Castellani some time since discovered a Greek family of goldsmiths who still practiced the art, which had been handed down to them from time immemorial. He gave a full description of the method of doing the work in THE JEWELERS' CIRCULAR. The collection of antiques, cameos, etc., of Signor Castellani at the Centennial Exhibition was exquisite, and contributed largely to the development of artistic taste in this country.

A correspondent calls attention to No. 798 of the Cesnola collection in the Metropolitan Museum in Central Park. This specimen consists of a pair of ear rings, elongated in shape, said to proceed from excavations of tombs in Cyprus. Gen. Cesnola claims to have discovered one of the ear rings one day, and the other ear ring the day after. This pair of ear rings, it is asserted, is of New York make of 30 or 40 years ago, therefore not Greek, and not antique. The ear rings are made of a thin piece of gold, flattened by an indented roller, then curved in the shape of a long drop and roughly soldered on the edge. Some little rosettes are applied afterwards on the body of the drop as ornaments. The piece to go through the ear is of the regular shape of 30 years ago, with the small hinge to open and shut. Any old New York manufacturer of jewelry, it is alleged, would easily recognize this object as having been made here and not to be an antique Cypriote specimen.

James S. Birch, the well-known inventor and manufacturer of the Birch watch key, warranted to wind any watch without losing its grip, has recently had built for him at Pamrapo, N. J., a beautiful new yacht, which he has named the *Mark Twain*. The yacht was launched July 12, with much *éclat*. A large number of friends of her owner had assembled, and punctually at the hour appointed, two o'clock, she left the ways and glided gracefully into her native element. The ceremony of christening was performed by Miss Hattie McGiehan, the youngest daughter of the builder. Everything necessary for a trial had been prepared before the launch, and she left immediately after, accompanied by the Lily R., owned by Mr. Theodore H. Rogers, of the Jersey Yacht Club, to make her initial trip, her destination being Fire Island Light. Mr. Birch named his yacht after "Mark Twain," the well-known author, the genial humorist being a great favorite with the owner of the new craft.



VOLUME XIV.

NEW YORK, SEPTEMBER, 1883.

No. 8.

THE JEWELERS' CIRCULAR AND HOROLOGICAL REVIEW

*The recognized organ of the Trade, and the official representative of the
Jewelers' League.*

A Monthly Journal devoted to the interests of Watchmakers, Jewelers, Silversmiths, Electro-plate Manufacturers, and those engaged in the kindred branches of art industry.

SUBSCRIPTION:

To All Parts of the United States and Canada,
\$2.00 Per Annum; Postage paid.

To Great Britain, France, Switzerland, Germany, the West Indies, Mexico, the Republics of South America, and Australia, \$3.00 per annum. Postage paid.

All communications should be addressed to D. H. HOPKINSON, 42 Nassau Street, New York. Advertising rates made known on application.

The Business Outlook.

THAT GENERAL business has been prostrated during the past few months is a fact that has been brought home to business men in all branches of industry so forcibly that it would be folly to attempt to ignore or deny it. We may, however, endeavor to seek an explanation for this condition of things and also to see what lies beyond. Business has been depressed because of over-speculation in illegitimate enterprises. There has been, as it were, an over-production of stocks and bonds, issued to cover projected railroads which are not needed, to work gold and silver mines whose richness lay in the fertile imaginations of those who projected the speculations, and upon other visionary schemes that had no tangible substance. The public has been led to put its money into these wild ventures, and finding them unprofitable, has been made suspicious of even those substantial enterprises that are useful and profitable. Because these impossible railroads were swindles, railroad securities have had a tumble in price; because wild-cat mines were failures, mining stocks became a drug in the market. In short, there has been a collapse in the stock market, and a panic was averted only because the general public, and not a few operators, were interested. Individuals pocketed their losses of a few hundreds, or possibly thousands, of dollars, said little about it, but became suspicious of all enterprises. Instead of investing what was left of their fortunes in business, they have preferred to put it in securities that brought them low rates of interest but have the merit of being safe. The unsettling of the stock market, in which so many thousands are interested, always has a tendency to depress legitimate trade. Everybody becomes fearful that a financial panic is to be apprehended, and trim their sails accordingly. They sell whatever they can at a profit, and buy only what they are obliged to. They wait, like Micawber, for something to turn up rather than bend their energies to turning up something. So, while stocks of all kinds fluctuate in the market, legitimate business pines and

languishes. The public would be astounded if made aware of the great number of business men—not regular stock operators—who are interested in the stock gambling operations of Wall street. They read of fortunes rapidly made by these operations, and being ambitious to acquire sudden riches, they try a “flyer” of a few hundred dollars in stock operations, withdrawing from their regular business capital that should be used for its advancement, and eventually become absorbed in the rise and fall of various stocks, and in the buying and selling of things they have not—in operating, in short, in fictitious values. They are stock gamblers, lacking the courage to say so. Fortunate is he who, after being scorched, as he almost inevitably will be, has the moral courage to forswear the fascinating but dangerous game, and to devote himself to his legitimate occupation. It is because so many business men are engaged in this most destructive of all gambling operations, that legitimate trade is so suddenly and seriously affected by a disaster in the stock market. During the past few months there has been much uneasiness in stocks of all kinds, and to this unsettling of fictitious values may be attributed largely the depression in all kinds of honorable business, precipitating some heavy failures and thus adding to the disaster. We know of no other reason for the stagnation that has characterized the jewelry trade during the summer months—the people have been fearful that a panic was hanging over us and there have been few buyers.

There does not seem to be any good reason why this state of things should continue. At the present writing there promises to be an abundant harvest of all staple crops, and this is such a source of wealth that it must serve to set in active motion once more the wheels of commerce. The harvesting and transportation of these crops gives employment to many thousands of men, and unlocks millions of treasure. Foreign gold floods the market to buy our wheat, corn and other crops, and every industry is stimulated by the circulation of money, thus called out, and without which they cannot live.

The jewelry trade is in an excellent condition to realize any benefit that may come from the bountiful harvests and the consequent enlivening of general business. Retail dealers are not overstocked with goods, they have met their obligations with considerable promptness, and now have excellent credit. When the demand for goods comes to them they can get all they want at short notice, fresh in design and attractiveness. The manufacturers have not been very active during the summer months, but are, nevertheless, fully prepared to furnish the retail trade with all the goods desired. They are not overstocked at present, but, at the first symptom of returning activity, are prepared to set their factories running, and supply standard goods and many novelties without delay. We may say that the trade generally has been kept well in hand, and will be able to meet the fall demand with alacrity and ease. The general feeling seems to be that there will be an average demand for goods during the fall; the more sanguine hope for a “big trade,” especially in holiday goods, but the more conservative will be fully satisfied if the demand reaches the volume it attained last year. We see no reason

why it should not. The financial panic that was apprehended has been so long delayed that the causes that excited alarm have spent their force; the danger has passed, leaving but a scattered wreck here and there behind. The harvest time is upon us, and careful estimates made give assurance of crops better than the average. When money for these is realized, their producers will feel easy, and the retail trade will become active. We anticipate a liberal demand for goods in all branches of the trade from now till after the holiday season, and, notwithstanding the dull summer, we predict that the books will show, at the end of the year, a fair average in the volume of business transacted.

More Art in Wrought Gold Required.

THAT AMERICANS are rapidly developing an appreciation for the highest order of artistic excellence has long been admitted. The fact is demonstrated by their liberal purchases of paintings, statuary, etc., and the high prices paid by them for rare specimens of the works of the old masters. When the fortunate possessor of such a work consents to place it on exhibition, as is frequently done, crowds flock to see and admire its wonderful beauties. The appreciation of high art is becoming general, as is shown by the quiet decoration of the homes of all educated or refined persons, in which a few artistic pictures or other creditable works by good artists have driven out the numerous cheap chromos and other tawdry decorations that were formerly found on every hand. This demand for art is not confined to the wealthy by any means, but, on the contrary, is more apt to be found among persons who are not classed with our millionaires but are more noted for education and refinement than for riches. There are, however, among these, thousands who derive their chief pleasure in surrounding themselves with those refining influences, literary and artistic, that appeal strongly to their finer sensibilities. The number of persons to be enumerated in this well-to-do refined class has been greatly increased in the past few years by the addition of the cultured offspring of our self-made millionaires and very rich men, who are intent upon giving to their children the advantages of education that were, in their struggles for wealth, denied to them. A half century ago the number of families in New York City regarded as exceedingly wealthy could be counted on the fingers of one's hands, while now they run up into the thousands, while every prominent city and village in the land can boast of individuals whose wealth is counted by the hundreds of thousands of dollars. In a country so prolific in resources as ours, the accumulation of great wealth is comparatively easy, and our enterprising people have missed few opportunities presented to them. As a consequence of this accumulation of wealth in the hands of so many individuals, education, artistic culture and social refinement have had a wonderful development among us. Not the least among the facilities which wealth affords for such development are those for extended travel, and the restless adventurous spirit among Americans has sought gratification in this manner. The army of tourists we send abroad every year comes in contact with the highest art development of the old world, and naturally brings home new and advanced ideas, more refined tastes, and a better appreciation of what our own artists are doing. The growth of art in this country, but more especially the development of appreciation for it among the well-to-do classes has made rapid strides during the past twenty-five years. Fortunate are they who, seeking to gratify this comparatively new-born artistic taste, have sufficient foresight to see to what it must naturally lead, and to prepare to reap the commercial results that must naturally follow. This demand for high art has a commercial value; it must be catered to and satisfied. If this is not done by our own enterprising artists, then it will be done by foreigners, and our innumerable tourists will spend abroad the wealth that should go to enrich native talent.

There is much in the conditions surrounding the development of art-taste in this country of which the jewelry trade should take

advantage. To some extent this has been done, but there remains much more to do. Especially have our goldsmiths an opportunity to distinguish themselves in the production of gold goods of superior artistic merit. They have made rapid advances of late years, but, in our opinion, have failed to accomplish all they might have done. Instead of devoting themselves to the production of artistic works possessing real merit, because of the high order of skill bestowed upon their workmanship as well as in the excellence of the designs, they have been led to follow false gods, and to reproduce with much skill, imitations of imitations. That is to say, they have copied the works of foreign artists which were themselves but copies, and may have been diluted half a dozen times by being sifted through the brains of as many different workmen. The original work may have been worthy of reproduction in gold, but in the various copyings much that was meritorious was lost. This has been especially so in the reproduction attempted of Chinese and Japanese works of art. To the native artists, their work meant something; they were elaborating something connected with the history, traditions, manners or customs of their country or their own people, and which appealed directly to the artistic sentiments of their people. In such a work they could concentrate their best endeavors, for to them it had a well defined and generally poetic interpretation. To the European or American artist there was no poetry or sentiment in such productions; they simply saw the hard mechanical facts that stood out in the work, representing only the mechanical skill of the workmen, and sought to reproduce that, and that only. The subjects made no appeal whatever to artistic taste, and it is not surprising that the demand for such goods soon wore itself out. They had no place in the archives of universal art, and only caught the eye of the collectors of curios. Art that allies itself to the peculiarities of a nation will not bear transplanting, especially to a democratic country like ours, any more than will the customs and manners of different peoples. We welcome the people but not their peculiarities. So while we can extend a hearty welcome to true art, the peculiarities or eccentricities of art do not find that recognition from those to whom all must look for the encouragement and development of everything of an æsthetic nature. The reproduction of such work does not raise our art standard, however it may contribute to the improvement of our purely mechanical skill. Had the same time, labor and money been expended upon classical subjects, our gold workers would have made much greater progress in meeting the demand for artistic excellence, while their products would have had a lasting and substantial value. The production of gold goods in response to the demands of fickle fashion is not calculated to enhance artistic excellence, however much it may contribute to pecuniary success. While fashion must be recognized, there is something better behind it that is better worth catering to, and that is the demands of a pure, cultivated, refined taste that calls for the higher and more lasting forms of art. These demands have never been so fully met in any manner as in the manufacture of goods that embrace classical designs and the best workmanship. Our tourists return from Europe loaded down with jewelry of foreign make and full of admiration for the artistic wonders in this line they have seen abroad. All they admire in the goldsmiths' work seen abroad can be produced just as well here as there; we have the skill to do it, but it has been employed too much in supplying the demands of fashion, which has periodical fits of going crazy after certain styles, and then as suddenly abandoning them for something equally bad. Classical art, however, is always in demand, it has held its own for centuries, and the public turns to it, after one of its crazy fits, with relief and satisfaction. Our leaders in the goldsmiths' art would find it to their advantage to devote their energies to perpetuating the substantial classical school rather than to chase the ephemera of fashion's dictation. In painting and sculpture the classical is always fresh and always taking, and the same is true as to those specimens of the goldsmiths' art that bear the stamp of the same school. Old jewelry of this style has been handed down from generation to generation, as precious heirlooms, in many old families of Europe, preserved for the

beauty of its design more than for the mechanical skill expended upon it. But the jewelry of to-day is essentially ephemeral in its nature; it serves its purpose while it is the fashion, and then finds its way to the melting pot, to be superseded by something equally short-lived. Our workers in gold seek the transitory rather than the permanent. But there is a field and a market for those who aspire to better things. The appreciative taste is here, and the wealth with which to gratify that taste.

It is urged by the manufacturers of the fine grades of gold goods that the facility with which their costly work is reproduced in base metal is a great drawback to the production of such work. There is some force in this statement, but it does not apply to those higher works of art where the highest grade of skilled labor unites with the genius of the artist to produce a work of real artistic merit. Manufacturers of cheap goods must rely mainly upon machinery in their production; they cannot afford to pay for the hand labor necessary to the production of highly artistic goods, and there is, consequently, little danger of such work being copied by them. Besides, the admirers of such art-work do not want it in the cheap forms, so that there would be no market for it. It is when the manufacturers of fine goods rely upon purely mechanical processes that their designs are copied in base metals. Some idea of what the goldsmiths may do by improving the artistic character of their goods, has been done by the silversmiths. Wonderful progress has been made by the latter within the past few years in the character of their goods, some of which have reached a degree of artistic excellence that it would be difficult to surpass. The art education of the people has taught them to appreciate the improved character of silverware, and the consequence is that greater quantities of the best quality of goods are now sold than the manufacturers formerly dreamed it would be possible to dispose of. How catering to a refined taste tends to develop that taste is instanced in the experience of one of our leading silversmiths with a buyer in a western city. The buyer had been in the habit of ordering a small quantity of standard silverware every year, but on one of his visits East was asked to purchase some of the more artistic goods. He declared that he never could sell them in his community, but was finally persuaded to take a few on consignment. He was surprised at the result, for not only did his customers buy the goods he had, but ordered more, so that his purchases from the silversmith amounted to over \$30,000 the first year. Not only did he make his profit on these goods, but they gave him a reputation in the community for keeping the best of everything that was the foundation of his fortune. Our goldsmiths may well take a hint from their co-workers, and, while aiding to develop the artistic desires of the people, realize a handsome profit from their endeavors. What is wanted is a higher order of wrought gold goods to take the place of the ephemeral styles constantly coming up, and that will induce lovers of art work to spend their money at home rather than among the goldsmiths and jewelers of Europe.

Depthings.

[By J. RAMBAL, teacher of Horological School of Geneva, in *Allg. Journ. d. Uhrm.*]

INTRODUCTION.

THE following article is a condensation of two lectures delivered by J. Rambal before the Horological Society at Geneva, Switzerland. The orator did not intend to enter into all the details pertaining to the domain of depthing, on account of the limited time allotted to a discourse, he intended to confine his remarks to epicycloidal depthings, and to treat simply those belonging to this class, when containing a small number of leaves (below ten).

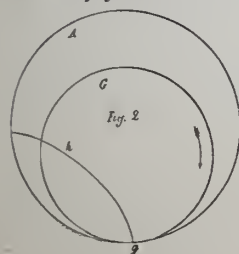

Figs. 2 to 5.—*A* pinion pitch circle; *B* wheel pitch circle; *G* generating circle; *g* generating point; *e e'* epicycloids; *h h'* hypocycloids. [In the theoretical fig. 5, it has been assumed that the pinion leaves are reduced upon a simple straight line.]

The orator has sought to present the subject in such a manner that it can also be understood by the workman who is not acquainted with geometry, and he has made use of simple means in his experiments to show the form of epicycloidal depthing curves. It is advisable that the reader describe these curves himself by means of the very simple auxiliaries always at the command of the watchmaker; a few discs of strong paper, which are to be revolved either outside or inside around a large box cover, which has previously been fastened upon a piece of paper, suffices for the purpose. Although this crude arrangement cannot replace the carefully constructed apparatus, still, it is sufficient to convey a good practical idea of the matter under debate.

I.—Theoretical part.

CONTESTS: Employment of pinions of a small number of leaves; 2. Center distance; addendum of tooth; rounding of leaves; pitch measurements of wheel and pinion. 3. Proportions of the pitch measurements to number of teeth. 4. Shape of teeth and leaves; uniformity of driving. 5. Depthing curves; generating circle; generating point; epicycloids; hypocycloids; three kinds of the latter curve. 6. Simultaneous production of tooth curve and leaf flank. 7. Size of leaf; commencement of driving before line of centers. 8. Lepine's depthing. 9. Ingald's fraises.

Pinions of a small number of leaves, generally six, sometimes even five, are most generally found in very old watches, which cannot astonish us when we consider that it was rather difficult to make them, and for this reason, the artisans of those "good, old times" contented themselves with so small a number. Little by little, means of working increased, the cutting machine was invented, and the greater exactness which became possible by its use also led to an increase of the number of leaves and teeth. The former were gradually increased to eight, next to ten, and, in high-priced watches for observation, we find them at present ranging from twelve to sixteen. It must by no means be concluded hereby that pinions of a small number of leaves have disappeared. Desirable as it would be, they will never be banished entirely.

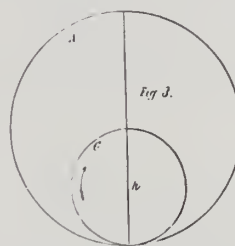

Small watches, with very minute parts, can accommodate only pinions of a small number of leaves; the same is also true of certain parts of larger watches. It becomes necessary, therefore, to find a way for producing them as perfect as possible; because they will always possess smaller or greater defects, which the watchmaker can only improve, never entirely overcome. This also explains the reason why a certain number of practical men possess each his own peculiar way for arranging depthings.

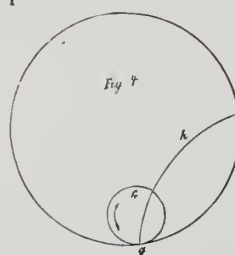

Before we pass on to practical matter, it is well to elucidate the elementary laws upon which the construction of depthings is generally based. Since this dissertation is limited only to pinions with few leaves, let us take as illustration the case of a wheel with sixty teeth and a pinion of six leaves.

2. The distance which separates the two pivot holes pertaining thereto is called the distance of centers; of course this corresponds to the circumferences of the wheel and pinion, and these two circumferences seize into each other to a certain distance, which is called the pitch of the depthing.

Let us next suppose that from the wheel teeth the operative parts, called the "addenda," have been removed entirely, also the roundings of the pinion leaves, and we will have by this process reduced said parts to what is called its "pitch" circle; the pitch circumference both of the wheel and pinion has thus been produced.

Therefore, the circular arcs corresponding to these circumferences

are the pitch arcs of each of these parts. Now, when these two circumferences are laid against each other, they will touch only at one point, and give very exactly the distance of centers.

3. As far as regards the depthing, the pitch circles of each of the two parts are of the highest importance, because they are the basis of the entire construction. The dimensions of these two pitch circles must stand to each other in the same proportions as the number of wheel teeth to that of the pinion leaves. This is a fundamental law, which must be observed inviolately.

The circumference of the pinion is next divided into six parts, and that of the wheel into sixty. The length of such a part is called the division of the depthing (see fig. 6).

4. Let us examine farther, what shapes the teeth and leaves are to receive, in order to comply with a very essential condition of the depthing, to wit, the uniform driving of the pinion by the wheel.

This condition of uniformity or of regularity of driving would be obtained if each of the moving parts were reduced to its pitch circumference. Of the two wheels, one would move the other by revolving, without sliding, such as occurs in rolling machines. This illustration offers the point of application for the construction of the wheel.

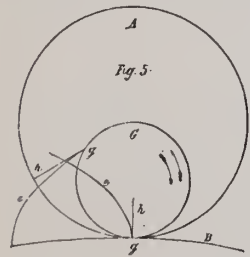

5. Let me say a few more words on depthing curves. Let us suppose a circle touch another circle, whereby the former revolves upon the latter. The point of contact, which also is common to the other circle, will thereby describe a curve, which is called epicycloid.

The latter circle is called the "generating circle," and the point the "generating point" of the curve.

Fig. 6.— e e' epicycloids, upon which the curves of the wheel tooth are based; h h' hypocycloids, which form the leaf-flanks; p

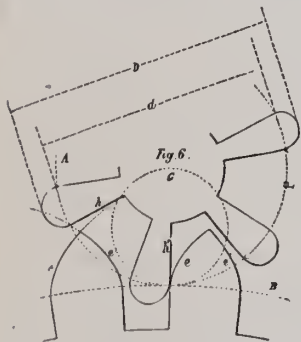

division of the depthing; d pitch diameter of pinion; D full diameter of pinion. (NOTICE. The thickness which the pinion leaf is to have [one-third of the pitch] necessitates that the two curves e and e' are sufficiently close to each other to permit the shake required by the depthing.)

If, in place of revolving one circle outside of the other, it is moved within the circle (fig. 4), a process analogous to the above takes place. If circle G is moved in the direction of the arrow, along the circle A , point g will describe a curve h , which is called a hypocycloid. If circle G is larger thereby than the one-half of circle A , the curve will move in the contrary direction. If, finally, circle G is taken of such dimension that its diameter be equal to the radius of circle A , then line h will become straight (fig. 3).

It will be easier, after the explanations, to understand the construction of a curve, which at the same time complies with the tooth as well as with the flanks of the pinion leaf.

6. Fig. 5 shows the pitch circle of pinion A in correct contact with the arc B of the wheel.

If the generating circle G (which is equal to one-half of A) is placed in such a position that the three circles will touch each other at one point, and if next the two smaller ones are revolved upon the larger one from left to right, always preserving their contact, it will be found that generating point g at the same instant describes the following motions: 1. An epicycloid e outside of circle B ; and, 2. A hypocycloid h within circle A .

If the circles are next revolved from right to left, lines e' and h' will result.

It is easy to see that if for the shape of the leaf flanks lines h and h' , and for the curves of the teeth lines e and e' are used, that the thus formed teeth will drive the pinion with uniformity, because the

flank of the leaf and curve of the tooth were formed by the same generating point.

It will already have been noticed that the point of intersection of the two curves e and e' is situated a little below point g , in consequence of which it does not touch leaf h .

Hence follows: When the next wheel tooth (not given in the cut) is situated upon the line of centers in contact with pinion leaf h' , that is, in the same position as h' in fig. 5, the preceding tooth has already left leaf h . It will be seen from the above, that the contact of the tooth with the pinion leaf h , even in the entirely impossible case that the leaf were reduced upon a straight line, ensues already before its arrival upon the line of centers.

7. Pinions with few leaves are generally made so that one of the latter is equal to one third part of the depthing division, whereby it becomes sufficiently strong. It is well not to exceed this proportion, otherwise the fault, inherent to all depthings with pinions of a small number of leaves, viz., the commencement of contact before the line of centers, is increased.

In order to cause the formed pinion leaf to become operative, it will be necessary to let curve e' (fig. 5) assume the position which it occupies in fig. 6; in which the curve is sufficiently far from the pinion leaf to permit full shake to the depthing.

This operation is for the purpose of essentially decreasing the pointed arch (addendum) of the tooth, whence follows that the wheel tooth already long ago left leaf flank h , before flank h has arrived upon the line of centers.

8. Watchmaker Lepine, whose name will be celebrated for all time, endeavored to improve the depthing in this respect, by retaining the full or nearly full length for one of the curves of the tooth. Of course he could not by this disposition preserve the symmetry of the two curves, wherefore depthings according to his system can be driven only to one side.

9. Concerning the use of the Ingold fraises, the principles upon which the construction of a depthing is based, have been adhered to.

The fraise itself may be compared to a pinion. To alter a wheel, the diameter of the fraise must be chosen thus that it stand in the same proportion to the pitch diameter of the wheel as the leaves and teeth of pinion and wheel do. The side of the cut of the fraise will then form a hypocycloid, having as basis the same generating circle with the leaves standing in depthing with said wheel. These conditions are indispensable. The proportion between tooth and interval of the fraise must be corresponding to the same proportions at the wheel teeth.

(To be Continued.)

Remarks on the Construction of a Seconds Regulator.

[By A. DRÜSSEL, mechanician, Royal Polytechnicum, Stuttgart, in *Allg. J. d. Uhrm.*]

ALREADY the ancients sought to construct mechanisms with which they might measure certain intervals of time, say from sunrise to sunset, or from one sunrise to the other. Their apparatus for this purpose were of a very primitive nature; their first time gauge was the sun dial; next, the hour glass, from which a definite quantity of sand passed in a given time; the clepsydra was introduced at a later date, by Heron, of Alexandria.

The periods of time measured by these contrivances were not even approachingly concise; only afterward, after the invention of the wheel clock, in the fourteenth century, it became possible to measure short intervals of time with anything like precision. Tradition says that the first wheel clock was constructed by one Henry von Wick, about 1324.

Although the above remarks are simply an introductory of said author to his article, about to follow, we will at this period of his remarks interpolate the following from a European source, headed :

THE FIRST PENDULUM CLOCK.

In the Royal Institute of "Studii Superiori," Florence, is a copy of the drawing representing the first idea of the application of the pendulum to the clock, dictated by Galileo, then blind, to his son, Vincenzo and his disciple Viviani. It is elucidated on the original of the Galilean manuscripts in the Biblioteca Palatina.

In an account which he gave Prince Leopold de Medici, Viviani, after having described Galileo's experiments on the pendulum, and

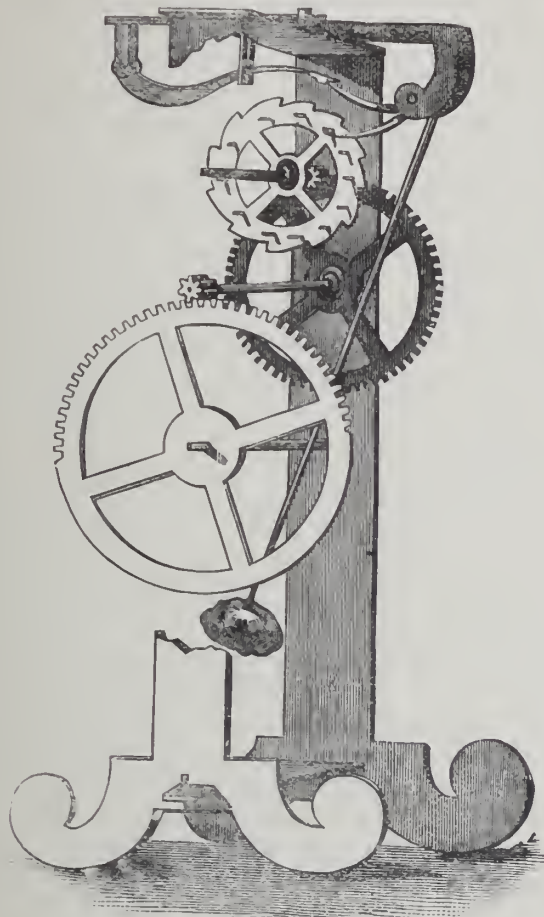

the way in which he applied it to the measurement of time, continues thus: "but, as Galileo was most liberal in communicating his inexhaustible speculations, it frequently happened that the uses and newly discovered properties of his pendulum, spreading little by little, fell into the hands of persons who adopted them for their own end, or inserted them in publications, and by artfully passing in silence over the name of their true author, made such use of them that it was believed—at least by those who knew nothing of the origin of the discoveries, that the writers were the real authors of them. He next speaks of the observations of the 'Stelle Mediciée,' of the tables relating to them prepared by the Padre Renieri, of the offering made by Galileo to the States General of Holland of his method for determining longitudes by means of the eclipses of Jupiter's satellites, and of Galileo's determination to send his son, Vincenzo, and the aforesaid Padre to Holland, since he himself, being old and blind, was unable to travel thither." He then continues: "while, therefore, Padre Renieri was employed on the composition of the tables, Galileo gave himself up to meditations on his time measurer, and I remember one day in the year 1641, when I lived near him in the Villa d'Arcetri, that the idea struck him that it would be possible to adapt the pendulum to clocks with weights or springs, and make use of it instead of the usual regulator, hoping that the perfectly equable and natural motion of the pendulum would correct all the defects in the mechanism of the clocks. But as his blindness deprived him of the power of making plans and models of the designs he had formed in his mind, his son, Vincenzo, having arrived one day at Arcetri from Florence, Galileo confided his ideas to him, and many times did they reason over the matter, and at last settled upon the method which is shown in the accompanying drawing, and then set to work at once

in order to practically overcome those difficulties, which, for the most part, it is impossible to foresee. But Signor Vincenzo intended to construct the instrument with his own hand, in order that by this means the secret of his invention should not be reported by the artificers before it had been presented to His Serene Highness, the Grand Duke, his master, and to the States General (to be used for determining the longitude); but he put off the execution of his work so frequently that a few months later, Galileo, the author of all these admirable inventions, fell sick, and on the 8th of January, 1641, "ab Incarnazione," (from the day of Incarnation), according to the Roman style, he died; and it was not until the month of April, 1649, that his son actually began to make the present clock upon the idea explained to him by his father, Galileo. He then managed to obtain the services of a young man—who is yet living—named Domenico Balestri, a locksmith, who had had some experience in making large wheel clocks, and he made him construct the iron frame, the wheels and arbors; but the tooth cutting and the remainder of the work he executed with his own hands, constructing on the highest wheel, called the safe wheel (*tacche*) twelve teeth with, as many pins (*pironi*) spaced between the teeth, and with a pinion of six leaves on the same arbor, and another wheel of ninety teeth, which moves the above mentioned. He then fixed on the side of the support, which is at right angles to the frame, the detent (*scatto*), which rests on the scape wheel, and on the other side he fixed the pendulum, which was made of an iron wire screened at the lower extremity for the attachment of a ball of lead, so that it could be lengthened or shortened for regulating. When this much had been done, Signor Vincenzo wished me (as one who was in the secret of this invention, and who, indeed, had urged him on to complete it) to see, by way of trial, the combined working of the weight and of the pendulum.

I observed the mechanism more than once, and his workman was likewise present. When the pendulum was at rest it prevented the descent of weight; but when it was raised and then let go, in passing the perpendicular, with the longer of the two arms attached to the pivot of the pendulum, it raised the detent which fits into the scape wheel, which wheel, drawn by the weight in rotating with its higher part moving toward the pendulum, pressed with one of its pallets on the other shorter arm, and gave it, at the beginning of its return, an impulse sufficient to cause it to swing to the height from which it had started, so that when it fell back naturally, and had passed the perpendicular, it returned once more to lift the detent, and immediately the scape wheel was set in motion and gave a fresh impulse to the pendulum; thus, the swinging of the pendulum was rendered continuous until the weight had reached the ground. We examined the operation together, connected with which, however, many difficulties arose, but Signor Vincenzo did not doubt but that he would be able to overcome them all; indeed, he fancied that he would be able to apply the pendulum to clocks in a different manner, and by other inventions; but since he had got so far, he wished to finish it on this plan, as the drawing shows it, with the addition of hands to show the hours and even the minutes. For this purpose he set to work to cut another cogwheel. But whilst engaged in this work, to which he was unaccustomed, he was seized by a very severe attack of fever, and was obliged to leave it unfinished at this point, and on the twenty-second day of his illness, on the 16th of May, 1649, all his thoughts and aspirations, together with this most exact measurer of time, were forever lost to him. He, their author, passed away to measure (let us hope), in the enjoyment of the Divine Essence, the incomprehensible moments of Eternity.

So far the interpolation. We again commence with our author.

For the propulsion of a clock with wheels, either the elasticity of a steel ribbon or the pressure of a weight upon a drum was employed. For preventing the wheel-work from running down too rapidly, either the fly or an anchor was employed.

In the clock of Henry v. Wiek, the teeth of a wheel operated in a similar manner as by us at present the balance of a watch, a toothed wheel was set into operation by means of a weight. The wheel

teeth set a vertical arbor in motion, to the upper part of which a crossbeam with slidable weights was fastened. It became possible hereby to alter the velocity of revolving and to ascertain definite periods of time.

It is well known that modern pendulum clocks are chiefly the result of the invention made by Huyghens, about 1658.

The construction of these clocks might be summed up as follows: A falling weight sets a drum into motion, which is provided with a number of teeth, by which, again, the wheels are moved. The unduly rapid motion of these wheels is prevented by the escapement. The oscillation of the pendulum to right and left divides the motions into equal intervals. If the pendulum were to oscillate of its own accord, it would soon come to repose by the resistance of the air and the friction at the point of suspension; fresh impulse is imparted to it by the wheel-work, whose motion only ceases with the running down of the impelling weight.

I will next speak of the regulator manufactured by me. It is provided with a seconds pendulum and Graham anchor, and runs fifty days. The falling height of the weight amounts to 1.4 meters (4 feet 7 inches), the diameter of the drum 60 mm. (2.36 inches), number of coils around the drum 12; time of revolution of the fourth wheel, with a seconds pendulum, in one minute (1). Number of teeth of fourth wheel, 30; consequently, by the seconds oscillations of the pendulum, the anchor leaves only one half of the tooth, wherefore two oscillations are necessary until a fourth wheel tooth passes beyond the reach of the anchor.

In the construction of this regulator I had made it my task to manufacture it without the customary minute work, which generally consists of three different wheels: 1. On account of simplicity; 2. In order to dispense with every superfluous wheel, which only consumes power, by causing additional friction, and to fix the several hands, the seconds, minute and hour hands, upon the appropriate shafts. This was obtained by the following arrangement:

The fourth wheel turns once per minute around its axis; the center wheel in one hour, the so-called hour wheel in twelve hours, each once around its axis; consequently the following proportion of transmission is necessary: from fourth wheel to center wheel = 60 : 1; from center wheel to hour wheel = 12 : 1, and is obtained.

Fourth wheel pinion = 16 leaves, third wheel 80 teeth = 80 : 16 = 5.

Third wheel pinion = 12 leaves, center wheel 144 teeth = 144 : 12 = 12, consequently $5 \times 12 \times 12 = 720$.

The pinion of the hour wheel has 16 leaves, the drum wheel (combined with the winding ratchet wheel) = 144 teeth, consequently $144 : 16 = 9$.

The proportion of transmission of the movement would be: $5 \times 12 \times 12 \times 9 = 6480$.

The length of the cord employed is found by way of multiplying the number of coils with the diameter H (circumference of drum).

Diameter of the drum = 0.060 m. $\times 3.146 = 0.1885$ m.

The number of coils amounts to 12, consequently $0.188500 \times 12 = 2.262000$ m.; in round numbers, length of cord = $2\frac{1}{4}$ m.

The time of revolving of the hour wheel is in 12 hours = 1.

The drum wheel will revolve $144 : 16 = 9$, therefore 9 : 1, that is, in 9×12 hours once around its axis = 108 hours, and will unwind cord = 0.188500 m. The height of fall of the weight amounts to 1.4 m.; its time of running down is to take place in fifty days.

We must therefore multiply 50 days times 24 hours and divide with 108 hours (revolution of the drum), that is, the revolution of the drum will occur 11.55 times in 50 days; cord would thereby be unwound 11.55×188.500 mm. = 2.158 m.

The weight is furnished with a simple cord and pulley, it therefore will only unwind $2.158 : 2 = 1.079$ m.

The running down of the cord coiled around the drum is found by multiplying the known proportion of transmission; in this case, therefore, = 6480, with the number of the coils = 12; therefore, $6480 \times 12 = 77,760$, divided with the number of minutes, $77,760 : 60 = 1296$, divided with the number of hours, $1296 : 24 = 54$ days in which time the cord would have completely unwound itself.

(To be continued.)

The Jewelers' Security Alliance.

WE HAVE received numerous inquiries as to the objects and purposes of this organization from dealers in different parts of the country, and will here endeavor to answer them all. Owing to the great number of burglaries committed upon the stores of retail dealers, and knowing that many professional burglars were "on the road," seeking opportunities to rob the safes of jewelers, the manufacturers and jobbers thought that an organization that should have for its object the rendering of assistance to such dealers as might be robbed, would benefit both the dealers and themselves. They were not entirely unselfish in the matter, for, so long as they sell goods on credit, they have an interest in the welfare of the dealers; if one of these meets with a heavy loss, he is liable to be so embarrassed that he cannot pay his debts; indeed, there are comparatively few dealers so well off that a \$5,000 or \$10,000 robbery would not impair their ability to satisfy their creditors. To this extent, therefore, the jobbers and manufacturers have an interest in preventing their customers from being robbed. But where they would lose one dollar by a robbery, the dealers are liable to lose ten times as much, so that their interest in protecting their property is far greater. The Alliance was the outgrowth of this mutuality of interests, and the fact that numerous robberies have been committed, and that others were contemplated.

When a jeweler is robbed by burglars, it is rare indeed that the thieves are captured or the goods recovered. The victim is dependent upon the local police authorities for assistance, and the expense of following up the robbers is greater than he is willing to assume, where the possibility of recovering the goods is so remote. The Alliance proposes to assume this responsibility and this expense. They propose to employ the best detective interest in the country to hunt down burglars who rob the safes of jewelers, to recover the property and to prosecute the thieves. Experience teaches that it is a long chase to hunt down burglars, and their conviction is attended with much difficulty and great loss of time. Detectives trained to the work are the proper persons to undertake this duty. The Alliance substantially says to the retail dealers, "on payment of \$10 membership fees, and \$5 annual dues, we engage to furnish you, in case your safe is robbed, the best available detective talent, to pursue the thieves, and to recover your property; we will pay the expense of the pursuit and the prosecution, and do all that it is possible to do to secure the conviction of the robbers." This is certainly something very much to be desired. It relieves the victim of a robbery, of all the care and expense of an effort to recover his goods, and divides it among all the members.

We are asked if this protection is extended to the entire stock of members. It is not; only to goods contained in the safes. It is presumed that, after business hours, the more valuable portions of a jeweler's stock are placed in the safe; this being known to burglars, they pay their attention especially to safes. If the Alliance were to undertake to protect the entire stock of its members from sneak thieves and dishonest employees, the expense would be too great, and would necessitate levying frequent assessments upon members to defray the expense. The organizers, therefore, of the Alliance, thought it best to limit the protection offered, to the most important peril, and to endeavor to circumvent the professional burglars. This is certainly an important work to do, and the retailers are very generally recognizing the fact by sending in their names for membership. To each is issued a certificate, which is intended to be framed and hung up in the store of the member, where it serves as a notification to burglars and thieves that the jeweler is under the protection of the Alliance. This is of itself a measure of protection, for it is an assurance to the criminal classes, that they will be prosecuted to the fullest extent, if they venture to practice their arts upon the safe of the dealer. There is no question but there is a field of usefulness for the Alliance to cultivate, and it is to be hoped that every dealer in the country will avail himself of the protection it offers.

Celebrated Horologists.

VOLTAIRE AS AMATEUR WATCHMAKER.

DR. F. GERLIER, of Ferney, Switzerland, has written and published a very readable article, in commemoration of the centennial of Voltaire's birth; it was first published in an obscure French provincial paper, from which it was culled by the *Journal Suisse d'horlogerie*.

The biography life of Voltaire, says our author, has been treated exhaustively by his several biographers, and still it appears to have been entirely forgotten that the great philosopher at one time was engaged in a horological commission and commercial business, and we treat this fact with all the importance it deserves. If some literary man were to look through his correspondence after the year of 1770, he would most assuredly be surprised at the large quantity exclusively devoted to advertising his goods. We, for our part, have culled from the letters, as carefully as possible, everything bearing on the development of the watch industry of Ferney, and of the means used by him for the purpose, by which this colony, in the short space of time of two years, became a commercial center which sent its productions over the entire old world. It is true that this prosperity was only of short duration, and the glory of Ferney departed with the departure of Voltaire; nevertheless this enterprise, sole of its kind, is worthy a closer examination, even if it were only for the reason of showing the great zeal evinced by the philosopher for the welfare of the workmen dependent on his exertions.

At the old headquarters of watchmaking, Geneva, great contentions and animosities had arisen between the watchmakers; not alone was the right of citizenship denied to a part of the natives of the city, but they were also sorely pressed in their other civil rights; among other irksome impositions, they were prohibited from opening stores or offering their productions for sale. Finally, in 1770, matters culminated, and fifty of them were ordered to leave the city; they sought refuge at Ferney, where they were received by Voltaire. They brought nothing beside their two hands, but the latter set them to work at their vocation. Since, however, it was not sufficient to alone manufacture watches, it being equally necessary to dispose of them in market, our philosopher developed a most astounding activity for the welfare of his colony, one which causes us to admire his inventive talent.

Being an old and well-experienced courtier, he knew only too well that everything depended upon gaining the royal favor. Only the sovereign conferred at that time the patents, ecclesiastical places, patents of nobility, pensions, privileges, monopolies, orders of liberation and arrest, etc., in short, he arrogated everything to his prerogative, wherefore it was of vital interest to enlist the good favor of the king, in order to make it possible for the young glory of Ferney to enter into competition with other localities. But since Voltaire, as he himself satyrically said at one time, stood in correspondence with every other king except his own, it became necessary to employ diplomacy, in order to insure the coveted royal favor. Six weeks after the arrival of the Genevan watchmakers he wrote to the Duchesse de Choiseul the following:

Ferney, Faubourg de Versoix, 11 Mai, 1770.

"I take the liberty of sending to Madame la Duchesse the first six watches which we have manufactured at Ferney. We think them very handsome and very good,—but every author has a good opinion of his own works. The cheap price will doubtlessly suit the Abbé Terroi, since we manufacture watches of which the piece costs only 11 Louis d'or (1 Louis d'or ranged from 16s. 7d. to 18s. 9¾d. English). Those having the picture of the king in enamel and diamonds, only cost 25 Louis d'or, and the other with the picture of the crown prince and the diamond hands, only 17 Louis d'or. All these watches would cost one-third more in Paris. We work with the greatest economy and therefore should be entitled to the support of the minister."

This lot was very well received, and financially well responded to.

The two pictures betrayed the great skill of the workmen. But Voltaire was not the man to rest satisfied with this, his first trial. The 25th of August arrived and with it the day of St. Louis and the feast of the Louises of France. Doubtlessly at higher command, the Genevans observed the day with a gala dinner. The inhabitants of the city shared in the festivities, and as early as the 27th of August Voltaire wrote to the Duchesse of Choiseul:

"You will doubtlessly hear with satisfaction, that our emigrants instituted a small festivity on the day of St. Louis, among other recreations, one hundred people sat down to a dinner, there was a grand illumination in the evening, winding up with innumerable viva's for the king. It was a pleasure to see both our Popish followers together with Huguenots so unanimous in their opinions."

After this exhibition of loyalty, it was impossible for the powerful *ministerium* to ignore the colony at Ferney, whose people were so devoted to the king and country. It felt itself morally obliged to support them with a few orders.

Voltaire could soon afterward write, "The Duke of Choiseul favors my factory to the best of his ability. I am favored both by the king and the Duke of Choiseul."

These were weighty sentences for the French ambassadors in foreign courts, when asked for their kind interference by Voltaire. Indeed, on the 5th of June he sent them circulars, soliciting their excellencies for the support of his workmen at Ferney, either by direct orders or by recommending them to solid merchants of those countries. This step was generally successful, and at the same time no better way could be chosen for opening a market in foreign capitals. Only the minister at Rome, Cardinal de Bernès, did not even deem it necessary to acknowledge the receipt of the circular, wherefore the talented philosopher wrote: "I have never felt myself so much excommunicated as by the minister's silence." (It is known that Voltaire was excommunicated by the Catholic Church, on account of his liberal ideas; hence the coldness of the cardinal.)

Passing over several correspondences, we next come to a price list and letter sent by Voltaire to the Spanish Duke de Ossum, who had been appointed as ambassador by a *Ministerium* which had driven out the jesuits.

The price list is as follows:

"Dufour, Ceret & Co. beg leave to inform you that they have established a watch factory at Ferney, near Versoix, for the manufacture of all sorts of watches, the cases of which will, at command, be ornamented with enamel portraits; they are fully able to furnish to their patrons watches at a cheaper rate than other places, since they have been exempted from the levy of taxes by, and enjoy the protection of, the king of France.

Watch in smooth silver case	Louis d'or	3
" " engraved or engine turned silver case "	"	4
" " partly smooth silver case	"	4
" repeating	"	14
" in smooth, light gold case	"	7
" " 18 karat gold case	"	8½
" " gold case, 1 ounce in weight	"	9
" " engraved gold case of good work	"	10
" " case of colored gold, very fine work "	"	13
" repeating, in smooth gold case	"	20
" in engraved gold case	"	21
" " colored gold case	"	24 to 28
" and cylinder movement	"	32 to 38
" in colored gold case and sec. hand	"	42

We guarantee for two years all watches above 8½ Louis d'or.

DUFOUR & CERET.

Voltaire sought not only to obtain the favor of ambassadors; he wrote to everybody on the slightest pretext; he knocked at every door, and in a letter to the Duchesse of Choiseul, April 9, 1770, he says, "I have smuggled a petition to the king in my pocket; I would send such a one to Divinity—yea, to the very devil, if we had one,

and I would hold it to be a stroke of policy to recommend myself to his good offices."

He evinced in his role of petitioner as much patience as passion, and was a man who could exhaust his friends and their good favors.

The great Catharine of Russia responded in a very royal manner to his solicitations, ordering twenty thousand dollars worth of watches at once, and to enforce her order, sent the money, in spite of the Turkish war in which she was engaged.

As far as Frederick the Great was concerned, he was too cunning to throw his money away in this manner. Voltaire knew this and was not surprised at the silence. Frederick himself was solicitous for the people to settle in his domain, and requested Voltaire for fifteen families, but it is not known whether they ever settled in Prussia.

It is unnecessary to follow our amateur watchmaker in all his devious ways and plans to raise the colony of Ferney into a prosperous condition. How the emperors of China and Morocco, the kings of Spain and France, the Cardinal de Richelieu, in fact every one who was supposed to have money, were in turn cajoled and threatened with being lampooned by the author Voltaire, in case they would not buy the wares of the watchmaker Voltaire. For instance, he wrote to the Chevalier de Lisle: "In what volume of the Arabian Nights have you read the anecdote that you could purchase a lady's repeating watch, ornamented with diamonds, for 18 Louis d'ors?" etc.

Thanks to such a patronage, the watch industry of Ferney rose in a short time to a high state of prosperity, and in the second year its commerce amounted to 500,000 francs per year; several different firms were established, Dufour & Ceret, Valentine & Co., Servand & Boussault, Daleizett Panrier, and finally that of the celebrated Lepine, who was at first established in a watchmaker's village, Challex, in the small county of Gex, in which also J. J. Rousseau had learned his trade as watchmaker.

But there was something deceptive in the fame and luster which hovered over the colony, only established two years. This superstructure was simply built upon sand, and sustained by the fame of Voltaire, the influence of his petitions, the large circle of his influential acquaintances, and the unexhaustible activity which he displayed, and he, as well as everybody felt that it would tumble down with him. He left Ferney against his will, anticipating the downfall of his colony. This, deprived of its soul, began to sink rapidly. The watches manufactured there began to be considered as a foreign article, and a tax was laid upon them. The Genevans, made wiser by experience, returned to their homes, and had no longer cause to complain of the reception by their fellow-citizens, since they also brought new commercial relations with them.

Although this undertaking of Voltaire was annihilated again, and time has effaced every trace, without a shadow of respect, it is deserving at least to be recorded in history, since the great philosopher spared neither pains, trouble nor expense to attain his purposes, whenever the good success of his colony was at stake. It is no wonder, therefore, that his name is remembered with gratitude by the inhabitants of Ferney.

Advice to Watchmakers' Apprentices.

BY A MAN WHO HAS SPENT TWENTY YEARS AT THE BENCH.

IN MELTING gold or silver one of the essential points to be obtained is an equal distribution of the heat; and thus in a great measure preventing the cracking and breaking of crucibles. A good form of melting furnace is shown in figs. 1 and 2. This is simply a draft furnace, and depends on a draft induced by a chimney or pipe, for the supply of air necessary to support combustion. The construction of such a furnace is very simple and inexpensive. The size of the furnace *A* should be about 8 inches square and 16 from the grate bars shown at *b*, fig. 1 to the covering plate *I*. Any out-building

or basement provided with a chimney (or even a stove pipe) will answer. To construct such a furnace: bricks are laid flat-wise, edge to edge, with mortar, so as to form a hearth, as shown at *G G*. The upper course of the hearth, as shown at *d*, should overlap the under, to allow of readily catching the ashes and cinders when the furnace is cleaned out (only the front need overlap). Fig. 2 is a front view of the same. In building up such a furnace, the manner of proceeding is very simple. The size of the furnace being the length of one brick square, makes the laying of the brick a very simple operation. An illustration of the plan of laying the upper tier of the hearth is shown in fig. 3. The lower tier can be laid any way so as to break joints with the upper tier of the hearth. The arrangement of the brick in the hearth shown, gives the best for cleaning out the ashes. The grate is of cast iron and lies on iron pins projecting from the mortar courses between the second and third courses of bricks in the furnace proper. The arrangement of the bricks can be seen on inspection of the cut. Above the fire box *A* is a horizontal flue *E*, rising into a perpendicular flue *F*; this perpendicular flue can be dispensed with and a stove pipe substituted by putting an iron plate on the line *a*; this plate being provided with a suitable flange to hold the pipe in position. The cover to the fire box *A*, shown at *I*, is simply a plate of iron—cast iron is the best, but thick sheet iron will answer. The manner of placing the fuel (charcoal or coke) is shown at *c c*. If your furnace has a good sharp draft, the fire can be perfectly controlled by means of the cover *I*, and a damper at the mouth of *B*; but the latter is seldom if ever needed. In case your chimney does not draw well an artificial draft can be made by forcing air into the

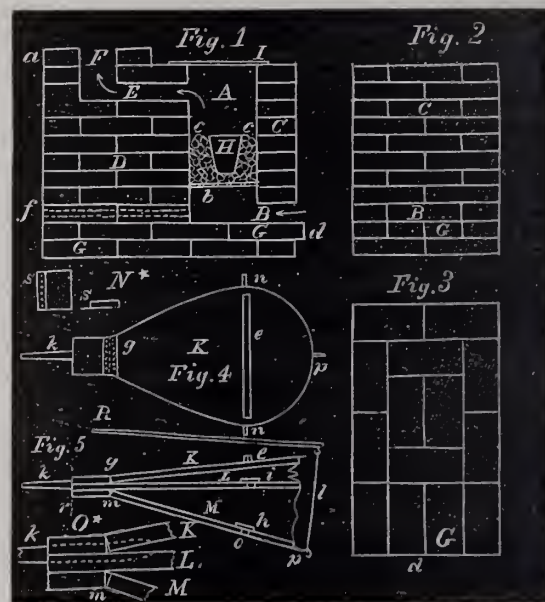

space below the grate with bellows. In this case, the mouth of *B* should be closed, and the air supplied by the bellows pass into the furnace either through the side or back of the furnace as shown at the dotted lines at *f*. A cheap and effective pair of bellows can be made of three boards and some enameled cloth, such as is used for carriage tops. The bellows used should be of the constant blast kind like those used by blacksmiths. Such bellows are superior to the rotary kind used in portable forges; and, by the way, portable forges for melting purposes are simply abominable, it being almost impossible to heat a crucible equally. At fig. 4 is shown a plan of such a pair of bellows. There are three boards shaped as shown at *K*; which lie one above the other as shown at *K*, *L*, *M*; fig. 5. These boards should be about 18 inches wide by 30 inches long, and shaped as shown in fig. 4; the part at *g*, fig. 4, is about 4 inches wide. These boards should be about 1 inch thick, and have cleats across as shown at *e*, *o*, fig. 5. Although this style of bellows is in almost every blacksmith shop, still the internal arrangement needs describing, and it would be well for any person who contemplated making a smaller one to examine one in operation. The central board *L* extends forward to the dotted line *r*, while the top and bottom boards *K*, *M* stop at *g*, *m*. Where these boards

end are joined three thicknesses of boards, as shown at *g*, *m*; these are glued together forming one solid block, and the top and bottom pieces *K*, *M* are joined by a strip of cloth or leather tacked across the joint; leather would be better for this place as it is stronger. At diagram *O** is shown an enlarged vertical section of this part, *g* and *m* indicating the strips of leather. The nozzle from which the air is expelled is shown at *k*; this iron pipe communicates with the upper air space or the space between *K* and *L*. The pipe *k* should be about one inch in diameter at the end inserted in the bellows, and the other end about $\frac{3}{4}$ of an inch. There should be a recess made in the boards to receive this pipe, as shown at the dotted lines in diagram *O**, and this recess should extend inward beyond the inner end of the tube *k*, so as to give the air free access to the tube even when the upper board *K* is near closed down, as shown in fig. 5. The interior valves or clappers are at the points indicated at *n*, *i*, fig. 5, and to understand their action, we must suppose the bellows in actual use. The middle board *L* has two iron pins protruding, as shown at *n n*, fig. 4; these are fast in two upright standards or posts, so as to allow the lower board to fall. Of course it is understood that the enamel cloth for the bellows' sides is carefully tacked on, so that as soon as the lower board *M* drops down, the air raises the valve at *h*, and fills the space between *L* and *M*. At *N** is shown the valve or clapper separate. It has leather covering the entire surface; the leather should be glued to the lower side of the block and extend backward as shown at *s*, diagram *N**, for nailing or tacking to the boards *L* or *M*. At *p*, figs. 4 and 5, is shown a piece of iron with an eye, as shown in fig. 5, to which is attached a lifting rod shown at *l*, fig. 5. In the boards *L* and *M*, immediately under the clappers, should be bored two 2-inch holes; the object of these clappers is to close these holes. To explain the action of the bellows, we will suppose the pins *n n* are inserted in two upright posts and the lower board *M* dropped down, the clappers *h* will rise and admit air into the space between the boards *L* and *M*; if now the rod *l* is raised by the lever *K*, air is forced through the holes under the clapper *i*, and the board *K* is raised and air forced out of the nozzle *k*. The three boards are joined by nailing on enamel cloth. A visit to any blacksmith shop will give a person the idea how such a pair of bellows are made, after the description given above of the valve or clapper arrangement. If with a furnace arranged as shown, and five or six gas jets are disposed around the crucible with air forced in with the bellows as described, a furnace can be made which will melt gold or silver without any ashes or cinders. Petroleum vapor, as we see in many gasoline burners, will effect the same result. In buying crucibles, if one buys in sets, the largest ones are very seldom used, and these larger ones can be applied to a useful purpose by breaking off the bottom and setting the smaller one into it, as one sets an earthen flower pot into a saucer; so, in case the crucible breaks, while melting, the broken crucible bottom will prevent the gold from getting into the ashes. The plan of using gasoline, kerosene or coal oils for a fuel would be by far the cleanest and cheapest fuel we could use, were it not for the danger of explosions; but coal gas is free from this objection, and if about six jets of good size are admitted to the fire box or furnace *A*, and a good supply of air furnished so as to make a perfect combustion, several ounces of gold or silver can be melted in a very few minutes. A very cheap form of rotary fan blast will be given in our next, and the reader can have his choice between it and the bellows just described. There is really but little to choose between them, and the facts are about these: the bellows on some accounts are the best, and the rotary fan the cheapest; but if one made the greater part of either the expense would be a mere trifle. The writer's idea in this article is to furnish the young artisan with facilities for working gold or silver at a comparative small cost of labor and money, and at the same time give such plans as are esteemed the best for practical use; as in case of the melting furnace above, this form is the best that has ever come under the writer's notice, and with a good sharp draft, will melt and refine gold perfectly. The bellows are a necessary make shift for lack of draft, and are indispensable if gas or petroleum is used.

Filigree Jewelry.

THE word *filigree* is derived from the Italian "filigrana" (*filo*, a thread or wire, and *grano*, a grain or bead), the old filigree work being ornamented with small beads. The name is now applied to delicate wire work ornaments, usually made of flat gold or silver wire, which is twisted into spirals and other convoluted forms; and these spirals, etc., are combined to form a sort of metallic lace work, which is shaped into brooches, ear rings, crosses, head ornaments, and others of a very light character. This work is chiefly done in Malta, India, Genoa, the Ionian Islands, and some parts of Turkey. It sometimes receives the general name of Maltese work.

Were we to trace back the origin of filigree work, we would find that India is the originator of the art, as it is, in fact, of everything else exquisite and æsthetic. And we shall devote the balance of this article to describing some of the most notable of the filigree *chefs-d'œuvre*s of Indian artists. It is a singular fact that India is the cradle of everything beautiful and poetic in shape and workmanship. At a European art collection we once saw among other articles a fan of gold filigree, representing the tail plumage of a bird of paradise, and two gold filigree necklaces, of so delicate a workmanship that it surpassed the fineness of Brussels lace. The chief attraction, however, was a silver filigree cord, worked so perfectly, with pieces so closely fitting together, that, although it was apparently a coherent solid piece, yet it possessed the flexibility of a silken thread, while the tools used in the manufacture were a pair of crucibles, a piece of bamboo serving as blowpipe, a few small hammers to beat the wire flat, and a few tongs for twisting it—this is the list of tools used in India for manufacturing the most delicate of filigree work.

The art of the Hindoos is similar to no other; it does not run into the bizarre of the Chinese taste, nor into the classical of the Greek and Roman, nor into the humdrum of modern art. It is separate by itself, complete in itself, it is more sober and strict than would be believed, even in its vagaries, and to sum up, it is an art which has never borrowed its ideas from outside sources.

Before we devote our attention to the main subject, we feel prompted to make a few remarks on the general state of goldsmithing and jewelry of India. Every one of the provinces of India has its own productions and perfections; it appears, however, that those of the north excel the south in matters of taste. Of the former we may principally mention Cachmere, Lahore and Punjaub. The beauty and harmony of the shawls of Cachmere, the gold embroideries of Dacca and Lahore are world-famed. But we desire to speak exclusively of the jewelers' work and its branches, which, in a country that yields the finest of all jewels, must, of course, attain to a high development. The possession of precious jewels is, in India, so essential a condition of the higher classes, that every sovereign, every small prince, supports his own jewelers, and by means of temporal and spiritual laws, the exact degree of kind and quantity of ornament is prescribed for each caste. The passion to possess ornaments is so great that the poorer classes imitate it with gold colored straws and the jewels with wings of bugs and handsomely colored seeds, if they are too poor to buy the base imitations.

As far as regards the extraordinary perfection of many of these objects and the difficulty of making them, even the most expert among us must simply express his astonishment at the few tools used and which have retained their shapes for thousands of years—unchangeable like the laws according to which the workman fashions his products and produces harmony.

We would not say by any means that the detail of Indian workmanship could in each case triumphantly withstand a vigorous scrutiny—but can this be said for European productions? We only assert that in the works of the Orient, the detail never becomes the leading idea, never obtrudes itself and stares the observer in the eye, that it always occupies its secondary rank, and is discovered only when attention is specially directed toward finding it, and toward ascertaining which is the cause of the beauty of the object.

Filigree may be said to consist in curling, twisting, and braiding fine pliable threads of the noble metal, and uniting them at their point of contact with gold or silver solder and borax, by the aid of the blowpipe. Small grains or beads of the same metals are often set in the eyes of convolutes, on the junctions or at intervals at which they will effectively set off the wire work. The more delicate tracery is generally protected by frame work of stouter wire. Brooches, crosses, ear rings, and other personal ornaments of modern filigree work are usually surrounded and subdivided by bands of square or flat metal, giving consistency to the filling up, which would not otherwise keep its proper shape. Probably the oldest existing jewel work is that which has been found by Belzoni, Wilkinson, Mariette, and other Egyptian explorers in the tombs of Thebes and similar places, in which filigree forms an important feature of the ornamentation. Among the jewelry now in the British museum and in the Louvre in Paris, are examples of the round braided gold chains of fine wire, such as are still made by the filigree workers of India, and known as Trichinopoly chains. From some of these are hung smaller chains of finer wire, with minute fishes and other pendants fastened to them. Most of the rings found in this collection are whipped with gold wire soldered to the hoop. The Greek and Etruscan filigree of about 3,000 years ago is of extraordinary delicacy and perfect execution. A number of ear rings and other personal ornaments found in Central Italy, are preserved in the Campana collection of the Louvre and among the gems of the British Museum. Almost all of them are made of filigree. Some ear rings are in the form of flowers of geometric design, bordered by one or more veins, each made up of volutes of gold wire, and this kind of ornament is varied by slight differences in the way of disposing the number or arrangement of the volutes. But the feathers and petals of modern Italian filigree are not seen in their ancient designs. Chains hang from the upper part in many ear rings, and birds, such as doves or peacocks, covered with enamel, are set among these hanging ornaments. Other Etruscan ear rings are short tubes of gold, half or three-quarters of an inch long by half an inch or less in diameter, with a plate of gold attached to the side, and the whole surface covered with filigree soldered on in minute patterns. Some exquisite specimens are made in the shape of a fish with its tail in its mouth, made up of thin plates of gold, and wire work of the same metal. Many bracelets and necklaces in that collection are made of twisted wire, some in as many as seven rows of braiding, with clasps in the shape of heads of animals of beaten work. Others are strings of large beads of gold, with grains of gold, or with volutes and knots of wire soldered over the surface. In the British Museum, a scepter, probably that of a Greek priestess, is covered with braided and netted gold wire, finished with a sort of Corinthian Capital and a boss of green glass. It is probable that in India and in various parts of Central Asia filigree has been worked from the most remote period without any change in the designs. Whether the Asiatic jewelers were influenced by the Greeks settled on that Continent, or merely trained under traditions held in common with them, it is certain that the Indian filigree worker retains the same patterns as those of the ancient Greeks, and work with them in the same way down to the present day.

The late Signor Castellani, who had made the unique filigree of the Etruscans and Greeks his special study, found it for a long time impossible to revive this particular process of delicate soldering; he collected examples of the peasant jewelry still made in many provinces of Italy, of extraordinary designs, preserved from an antique period, and it was in part through help of workmen in obscure villages, who retained the use of various kinds of solder, long forgotten elsewhere, that he was enabled to stimulate the fine reproduction of antique gold filigree, which have been so finely executed in Italy by Italian workmen. We are sorry to be compelled to chronicle the untimely death of this gentleman, which occurred at Naples, in the 59th year of his age. He may justly be called Italy's second Cellini.

Passing to later times, we may notice in many collections of mediæval jewelry work, reliquaries, covers for the gospels, etc., made either in Constantinople from the 6th to the 12th century, or in monasteries in Europe, in which Byzantine goldsmith's work was studied and imitated. These objects, beside being enriched with precious stones, polished, but not cut into facets, and with enamel, are often decorated with filigree. Large surfaces of gold are sometimes covered with scrolls of filigree soldered on, and corner pieces of the border of book covers, or the panels of reliquaries, are not unfrequently made up of complicated pieces of braided work alternating with spaces encrusted with enamel. Byzantine filigree work occasionally has small stones set amongst the curves or knots.

In the north of Europe, the Saxons, Britons, and Celts were from an early period skillful in several kinds of goldsmith's work. As early as the middle of the 5th century, the brooches and other personal ornaments of the "Littus Saxonicum" in England were encrusted with enamel work varied with borders or centers of filigree. The Irish filigree work is more thoughtful in design and more varied in pattern than that of any period or country that could be named. It reached its highest perfection in the 10th and 11th centuries. The Royal Irish Academy in Dublin contains a number of reliquaries and personal jewels, of which filigree is the general and most remarkable ornament. The "Tara" brooch has been copied and imitated, and the shape and decoration of it are well-known. Instead of fine curves or volutes of gold thread, the Irish filigree is varied by numerous designs, in which one thread can be traced through curious knots and complications, which, disposed over large surfaces, balance one another, but always with special varieties and arrangements difficult to trace with the eye. The long threads appear and disappear without breach of continuity, the two ends generally worked into the head and tail of a serpent or monster. The reliquary containing the "Bell of St. Patrick" is covered with knotted work in many varieties. A two-handled chalice, called the "Ardagh Cup," found near Limerick several years ago, has belts, bosses at the junctions of the handles, and the whole lining of the foot ornamented with work of this kind of extraordinary fineness. An Irishman, Lord Dunraven, numbers forty varieties of this cup alone. Much of the mediæval jewelry work, all over Europe down to the 15th century, on reliquaries, crosses, and other ecclesiastical goldsmith's work, is set off with bosses and borders of filigree.

Filigree in silver was practiced by the Moors of Spain during the middle ages with great skill, and was introduced by them and established all over the peninsula, where silver filigree jewelry of delicate and artistic design is still made in considerable quantities. The manufacture spread over the Balearic Islands, and among the populations that border the Mediterranean, and continues all over Italy, and in Albania, the Ionian Islands and many other parts of Greece. That of the Greeks is sometimes on a large scale, with several thicknesses of wire alternating with similar or larger bosses and beads, sometimes set with turquoises, etc., and mounted on convex plates, making rich ornamental head pieces, belts and breast ornaments. Filigree silver buttons of wire work and small bosses are worn by the peasants in most of the countries that produce this kind of jewelry.

Silver filigree brooches and buttons are also made in Denmark, Norway and Sweden. Little chains and pendants are added to much of this northern work. Beautiful specimens have been contributed to the various international exhibitions. Some very curious filigree was brought from Abyssinia after the capture of Magdala,—arm guards, slippers, cups, etc. They are made of thin plates of silver, over which the wire work is soldered.

Filigree is subdivided by narrow borders of simple pattern, and the intervening spaces are made up of many patterns, some with grains set at intervals.

(To be Continued.)

Method for Ascertaining Exact Error of Regulator from Time Signal.

A RECENT number of the *Deutsche Uhrmacher Zeitung* contains an article by G. H. Lindemann, in which he describes the method adopted in Glasshütte, Germany, by which correct time is obtained to within a hundredth part of a second. It is really taking advantage of the principle of the vernier, and as this seems to be quite an original idea it will, no doubt, interest many of our readers.

Beside the ordinary regulator, whose rate is to be ascertained, another with a half-second's pendulum, shortened so that 122 vibrations per minute are obtained, which, with an escapement like the spring detent, would make 61 escapes of the second hand per minute, is used.

An electro-magnet holds this short pendulum out of the perpendicular, so that the current from the Observatory sets it going at the instant of receiving the signal.

In a subsequent number of the same journal, a small error is pointed out by Herr Heid, in Herr Lindemann's paper, who says: "The principal object of the coinciding clock, that is, the one so regulated as to beat 61 per minute, is to ascertain the exact fraction of a second that has elapsed when the current arrives from the last full second observed or counted by the regulator. From this moment the coinciding clock comes into use. As this clock requires 61 beats = 1 minute, in order to come up to one beat of the seconds pendulum, when the two will beat as one, it follows that it will require so many less beats, as $\frac{1}{61}$ part of a second have elapsed of the already commenced second. For example: If the current releases the pendulum at 8 hours 1 minute $32\frac{1}{60}$ seconds, it will require still 51, and at 8 hours 1 minute $32\frac{2}{60}$ seconds, still 21 beats, in order with every one of them to come up $\frac{1}{61}$, to the moment of the beat of the regulator coincidence.

"Again, if the release of pendulum happens at 8 hours 1 minute, and between the 32d and 33d seconds, the problem to solve is to measure the part of the 33d second that has commenced. To do this, the short pendulum gains upon the long one $\frac{1}{61}$ part of a second at every beat, and if the coincidence happens at the 40th beat, it follows that the remaining 21 had already elapsed; therefore, the current arrived at 8 hours 1 minute $32\frac{20}{60}$ seconds, or, in decimals, 32.34 seconds, which would show the correction to be made to the regulator." From the further statements given, it appears that the dial of coincidence clock is divided into 60 parts. "Now," says Herr Heid, "would it not be more practical if it be divided into 61, the same as the number of beats per minute, whereby the coincidence always would take place at the number of vibrations shown by the dial, always supposing that the clock is properly regulated." This could be done with third wheel, 61; scape wheel, 8; pinion, 8.

Contributions to the History of Watchmaking.

WHO WAS THE INVENTOR OF THE ANCHOR ESCAPEMENT?

[R. T., in *Allg. Journal d. Uhrmacherkunst.*]

IT IS A deplorable fact that historical notices of our art are very scarce, and among the few, even, transmitted to us we will find many of a very doubtful reliability and the most varying statements are given concerning the same object. In this regard France excels all other countries, since at least the history of its own is passably well known.

The aspect of affairs is the same in Germany. Only the names of a few of its masters have been transmitted to posterity. It is hardly probable that such data have not been recorded, and the general obscurity of the sky historical may be due to the disinclination of parties to disinter the necessary tomes and folios buried under the dust of ages in the archives of the country. It is a very arduous task to undertake anything of the kind at the present late date, but it should be done, since both the honor of the country and of our craft demand it.

Being convinced of the importance of a thorough knowledge of our art, not alone to the craft, but also to the history of the world, we have undertaken to perfect it so far as it lies in our power, and commence with submitting to our readers a theme which is important enough to be deserving of all attention, in order to arrive at definite results. Nothing less than the priority, and therewith the honor of an invention is concerned, which in our time has attained to a very prominent development. We refer to the anchor escapement. It is generally accepted that it was invented by an English watchmaker, Thomas Mudge.

Before us lies a small essay, "Description des échappements les plus usités en horlogerie," in which we find the description of an anchor escapement constructed by one Pouzait, a Genevan watchmaker, and the entire execution of which almost permits us to assume that it is an entirely distinct escapement, unconnected with the English invention. It would next become necessary to ascertain which of the two is entitled to right of priority. The present material does not permit us to come to a final conclusion, since we do not know from what sources the author of the essay received his information, and we do not by any means intend to damage the reputation of a celebrated man in any manner whatsoever. Still we frequently meet with cases in history, where the same invention was made by different men at localities remote from each other. We may quote a case in hand from the first issue of the *Allgemeine Journal d. Uhrm.* A violent dispute based upon well-authenticated proofs, arose between several watchmakers, about the adaption of the cylindrical detent in the chronometer escapement, each of whom claimed it as his property. Also in this case, it is only just to assume that the same invention was made simultaneously by different persons and at different localities; wherefore we are tempted to pronounce the well known anchor escapement as the invention of Mr. Pouzait, and, therefore, of Swiss origin; and that it was afterward used with the English invention, by incorporating the advantages pertaining to each. All works on horology declare the name of this escapement to be "anchor" escapement, due to its shape as resembling a ship's anchor—a similarity for which, with the present construction, it requires a certain stretch of imagination. The original construction of the Swiss escapement, however, completely resembled a ship's anchor. Our presumption is still strengthened by the fact that the English call it "lever escapement."

Above-said work emanated from a report made in the year 1806 to the Institute de France, on the condition of horology of that time, which also awards to Mudge the honor of the invention, upon the statements made by Berthoud in his "Histoire de la mesure du temps." Berthoud says it was introduced in 1799, while the model of Mr. Pouzait, was already placed in the beginning of the year 1780 in the machinery collection of the "Société des Arts de Genève." Moritz Grossmann assumes 1760 as the period of the publicity of Mudge's escapement, while according to Pappe this took place as late as 1810. Saunier, in his *Grand traité d'horlogerie*, ascribes the invention to a Frenchman, Robin, which is an entirely unfounded assertion however. Although upon the above given data, of course, no one can rightfully be designated as the inventor of the escapement, still, we are inclined to award to Mr. Pouzait the honor.

We next append the chapter of said report on the anchor escapement.

The anchor escapement is named thus from the shape of its principal part, that distinguishes it and which has an approximate resemblance with a ship's anchor. Its invention is due to the clock escapement by Graham.

This escapement, in its originality and simplicity, presupposes a very small arc of oscillation, during which the tooth point of the ratchet form scape wheel remains in repose upon an arc, whose revolving center coincides with the motion center of the pendulum. During the motion of the pendulum, including the part of repose, the point of the tooth wheel rubs on the latter. This is consequently a dead beat, during which the motive power does not cease to

contains a slide *c*, movable up and down in a groove. These two pieces are provided with an elongated opening *o*, through which spindle *m* can pass freely through. Disc *d* may be eccentric with regard to spindle *m*, and its displacement may be effected optionally by means of screw *e*.

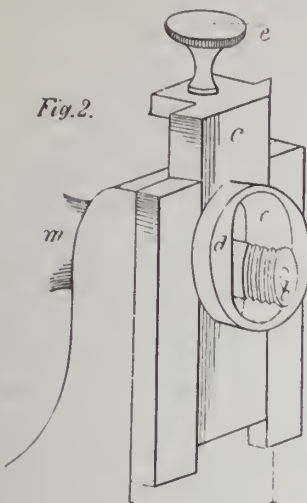

Screw-thread *b* (fig. 2) of the spindle *m*, carries a small chuck *z*, (shown in fig. 3). The middle of this latter, again, contains a slide *g*, which also carries a spindle *i*, provided with a screw-thread, upon which the thin disc *k* is screwed. The articles to be turned are cemented or fastened in some manner upon the latter. The two plates *h h*, are fastened upon the slide *g* in the center by the two screw nuts *u* and *u*, which pass through chuck *z*, and apply themselves at the circumference of disc *d*.

It will easily be understood that when spindle *m* is set in motion, disc *d* imparts to the supports *h h*, an alternate motion, and consequently also to slide *g* and plate *k*, which form one piece therewith.

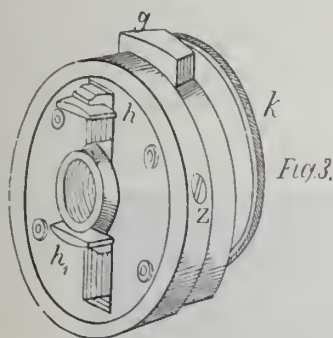

The article fastened against the latter when turned, assumes a more or less pronounced oval form, according as the center of disc *d* is moved more or less from the axis of spindle *m*.

This turning tool offers many special advantages; we have in fig. 4 represented five perfect ovals or ellipses. For 1 and 5, the radius *r* of the cutter represents the major and minor

radius of the represented ovals, while in 2, 3 and 4 it is set at angles 45°, 90° and 135°. From this it will be seen that ovals can be

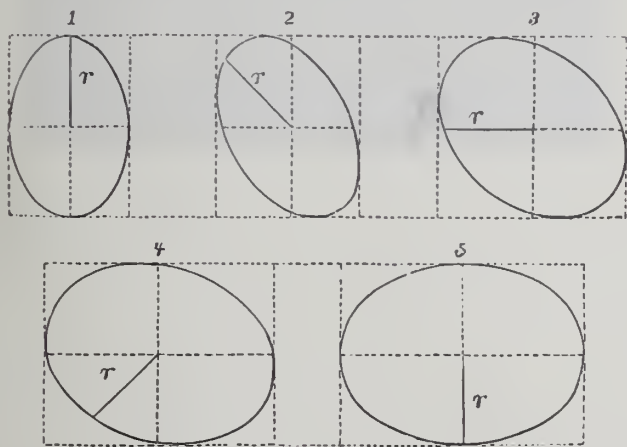

Fig. 4.

obtained with major radii of different magnitude; that the ratio of the major and minor radii is constant, and the vertical radii in the five positions is likewise a constant quantity.

How to Make and Engrave Silver Bangles.

BY EXPERT.

THE USE of silver ten cent pieces, engraved with monograms and crests, as bangles for bracelets, is getting to be so important a branch of the trade that a chapter devoted to the best and most expeditious methods of producing them cannot fail of being interesting. Although larger and smaller silver coins are occasionally used, still the same methods will answer for all; only varying the holders. Usually only one side of the coin is polished off, and if you have a universal lathe this is by far the best tool to flatten and smoothe this

side of your dime. If you have a run of such work it is well to polish, say ten at a time; as working in batches in this way is far more expeditious than to just fit up one or two at a time. As you cannot put your dime directly into the universal lathe and turn to the extreme edge, prepare ten pieces of No. 14 brass, 1 1/2 x 1 1/2 inch square, and drill a hole in the center about the size of an ordinary pin; put these pins into your universal lathe, and turn a recess, as shown at *B*, fig. 1, of the exact size of a dime, and to such a depth that it will receive the dime, only letting the portion protrude which is to be removed. At *a*, fig. 1, is shown a hole through the brass which is drilled after the recess is made, and is used as a guide hole for drilling the hole by which the bangle is attached to the bracelet. We will suppose we have ten pieces of brass as shown at *A*, fig. 1; now select ten nice full faced dimes and insert them in the recesses in the ten plates by heating and rubbing on a little black lathe wax. It only needs a little, and the coin should be pressed firmly down into the recess so as to be sure it is flat, and parallel with the face. We now put one of the plates in our universal lathe and face off smooth and flat; and repeat the process until all are flattened. A fine file will soon erase all traces of the turning tool. The process of polishing is, in fact, only a gradual destruction of inequalities, file marks, etc. After the file use a wooden buff with emery paper

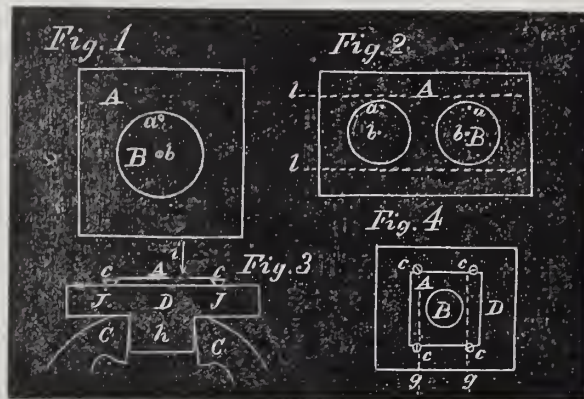

glued fast; these emery buffs for this purpose should be made of some wood, not too hard, but medium, say black walnut; and one inch wide and eighteen inches long, by one-fourth of an inch thick. The emery paper is of different degrees of fineness: commencing with No. 1/2 and ending with 000. If the reader can procure emery cloth it is best for this purpose; and it is best to make a dozen of these buffs at a time; as it is poor economy to try to do anything with a worn-out emery buff or a worn-out file. These emery buffs can be renewed by soaking them in water over night, and new fresh paper or cloth applied.

After the surface is finished with 000 emery paper, comes the buffing with a rotten stone and oil buff, to be followed with the rogue buff. But it would be well to give the process in detail, step by step. We will first describe the method if a universal lathe is used, and then speak of the most expeditious manner of proceeding if such a tool is not on hand. After the dimes are inserted with lathe wax into the pieces *A*, fig. 1, the piece *A* is inserted into the universal lathe, centering by the hole shown at *b*, and now at the back and center of the dime; next face off the dime smooth, and repeat the process until the ten dimes are turned off flat. I say ten, but of course one or any number can be manipulated in the same way. We next make a block of hard wood shaped in vertical section, as shown at fig. 3; and fig. 4 is a plan of the same seen in the direction of the arrow *i*, fig. 3. This block should be two inches wide, two inches long and one inch thick, and the grain of the wood run parallel with the jaws of the vise; the part *N*, which goes into the vise jaws (*C C*), is 1/2 an inch, and the table above, shown at *J J*, is also 1/2 inch thick. In the top of this block are four screws shown at *c*, to hold the plate *A* while filing and buffing it. The file and buffs are applied in the direction of the dotted line *g*. The face of *A* is nearly even with the face of the dime and serves as a guide in filing, and if the filing is carefully

done these pieces of brass will last for a long time. After emery buffing, the face of *A* with the dime should be carefully brushed with a hard brush to remove the loose emery, when it is ready for the rotten stone buff. This kind of buff is best made by taking the same kind of a piece of wood as recommended for emery buffs, and gluing a firm strip of chamois skin upon it. Probably most of my readers know that there is a vast deal of difference in chamois skins; the best kind for buffs being heavier and firmer—such as we generally see colored and sold as rouge chamois skins; an old one of this kind will cut up and make a dozen or two first-class buffs, but a precaution must be taken to wash the skin thoroughly to rid it of any and all grit, especially for the rouge buffs. The rotten stone buffs are used with oil and rotten stone, sperm oil being in all respects about the best. After the rotten stoning is complete and all scratches removed, the plates *A* and dimes should be washed with soap and water and dried in sawdust, after which they should be dusted with a soft brush to clean them. Now comes the polishing, which if you have a polishing lathe you need no instruction; if you polish with a rouge buff, the rouge can be used either dry or taken off from a rouge tablet by the buff. The polishing is effected by passing the buff rapidly across the face of the dime, bearing forcibly down, changing the plate *A* so as to make the buffing at different angles. I should have said in the earlier description that the edges of the plates *A* are beveled as shown in fig. 3, so as to bring the heads of the screws *cc* below the upper surface of the plate *A*, and consequently below the action of the buffs. The caution of extreme cleanliness in the different operations will ensure a brilliant polish; these precautions are to carefully dust off the particles of emery after using the emery buffs with a medium stiff brush, brushing hard and thoroughly; and after the rotten stone buffs wash with soap and water before using the rouge buffs. The dimes should be left in the plate *A* until engraved. The hole at *a*, for attaching, can now be drilled, countersinking to remove burr, with one of your round Swiss chamfering tools. In case you have no universal lathe fit up your plates *A* and get some one to turn them out with a universal lathe. The best way, however, if you have no universal lathe, is to fit up the plates with two sinks for dimes, as shown in fig. 2; the same holes *a* and *b* are used; *i. e.*, after the dime is complete heat the plate *A*, and with the point of some slim tool push through the hole *b*, and push the dime out of the sink. The greatest object in putting the dimes into *A*, for hand finishing, is to steady the file in filing off the fan. The best file for doing the rough cutting is a single cut file, to be got at any hardware store; and is applied to the dimes as shown at the dotted lines *ll*, fig. 2. A little care will soon enable one to face off the two dimes equally and also avoid touching the face of *A* with the file. After all the relief on the dime is removed, change to a fine double-cut file; then with your emery buffs proceed as directed above. If the above directions are carried out properly, there is no need of any stoning to remove file marks; *i. e.*, begin with No. ½ emery paper and finish with 000, when it will be ready for the rotten stone. The engraving is generally monograms, and after we have given some general hints we will treat of them, not only in regard to making them in good taste, but how to do them expeditiously. The customer usually insists upon some kind of a border around the edge, and it certainly adds to the finish. Those borders are in best taste which repeats itself at regular intervals, and it would hardly pay to space off a border and lay it out for each individual dime, consequently the best plan is to engrave up a number of different designs, and when we wish to engrave a border transfer from the engraved border on hand. These borders need not be on dimes; circles of the same size as a dime on a copper card plate are better, and in this way one can have ten or more on one card plate, and each different. The methods of transferring, as well as other hints, will be given in subsequent numbers of this journal, taking the matter up in regular order, from cutting (and designing) a simple monogram and border to elaborate ornamentation.

Lathes and Lathe Work.

BY THE MODEL WATCHMAKER.

IN MY last communication I gave instructions how to turn and finish a duplex staff, and in this I propose to give the manner of making a cylinder. Not that making a cylinder complete is, in a general sense, to be thought of, but only in extreme cases, such as cylinders of unusual size—that is, very large or very small. It is only recently the writer had a job of this kind. A lady's cylinder watch quite small; indeed the cylinder was two or three numbers smaller than any kept in stock; or, at least, New York and Philadelphia was searched pretty carefully without finding one. An idea of its size may be had by saying it was a trifle smaller (outside measurement) than a No. 7 sewing needle. The writer had often made large ones for English cylinders, but one as small as this was something new. But he found that the same manner of working, only being more careful, accomplished the job satisfactorily. As in the duplex staff described in my last communication, it is desirable to have a cylinder a little harder than can be drilled easily, consequently it must be partly finished before it is hardened. To go about making a cylinder as the professed cylinder maker does, with a brass seat for the balance to rivet on, and the hair spring collet, is not exactly the best mode. He has tools you have not, and a life time of experience in this one particular branch, and an operation which in his hands would be easily done, in yours would be an inglorious failure. For this reason, if no other, it is well to make the entire top of your cylinder of one piece of steel, roughed out as shown in fig. 1. This piece can be done in a split chuck, or any way to get

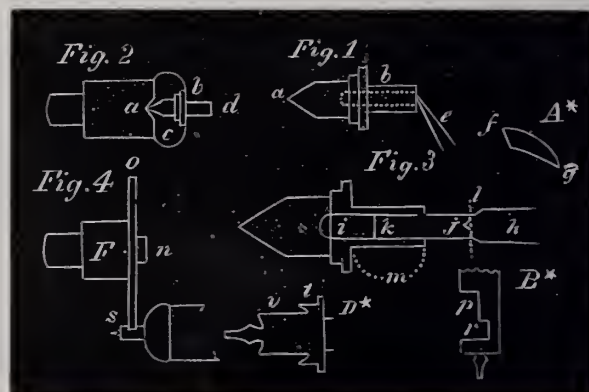

it in the shape shown in the cut at fig. 1. After it is got into the shape shown, it should be inserted into a wax chuck as shown in fig. 2 and turned up, when it should be centered and drilled as shown in the dotted lines at fig. 1. Great care should be used in making a drill of almost exactly the right size. This can be done by measuring across a tooth of your scape wheel from *f* to *g*, diagram *A**. When I say of almost exactly the right size, I mean a mere trifle too small, so that when the inside of the cylinder is ground out and polished, it will be *exactly* the right size. There can be no definite rule given for allowance in such cases, as in one instance a drill will cut rough, and the necessary amount of grinding and polishing to make the cylinder smooth on the inside would be double what it would in another, consequently good judgment and experience must be used in conjunction with your micrometer calipers. A few words in regard to cylinders in general may not be amiss. We frequently find cylinders with the points or heels of the scape wheel teeth stoned off by some botch; if the case is too bad, a new wheel must be put in. This fault is generally the worst if the heel or back end of the tooth has been molested, for this not only takes off the impulse, but renders the teeth untrue in the round, making the watch liable to set in the pocket. Almost every watchmaker has a theory in regard to matching cylinders to a scape wheel which has been tampered with in this way, some recommending as large a cylinder as will work successfully, others as small a one as will answer; but the true course is to put in one of the size the original one should have been; then if a new scape wheel is needed, the cylinder you put in will be, of course, all right; besides, in the

majority of cases, the best results will be obtained. The walls or sides of a cylinder should be as thin as is any way consistent with strength. After the hollow for the inside of the cylinder is drilled, as shown at the dotted lines in fig. 1, it should be tested for size; this can be done by inserting one of the teeth of the scape wheel and examining it with your double eye-glass. If one of the teeth goes finely into the hole (it is well to try several teeth, as the scape wheel teeth of ordinary watches are a little unequal in size) with only the least possible side shake, the hole is about the right size, as the subsequent grinding and polishing will enlarge it a trifle. After the hole is drilled to about the depth shown at the dotted lines, it should be ground out by using a piece of soft steel well turned to fit the holes; this can be easily done by leaving the rough cylinder in the wax and removing the entire chuck with the rough cylinder, and laying it aside until a piece is turned to grind out the interior. The chuck with the unfinished cylinder is now replaced in the lathe, and with a little fine oil stone dust and oil, with the piece we have just turned, we grind out the inside of the cylinder. At fig. 3 is shown a magnified longitudinal section of our cylinder, in which *i* represents the drilled hole, and *n* the piece turned up of soft steel to grind it out. The ordinary oil stone dust should be crushed very fine for this operation, and mixed into a thin paste with watch oil. After the inside of the drilled hole shown at *i*, fig. 3, is smooth and free from scratches, the outside of the cylinder shown at *b*, fig. 1, should be turned to the correct size for the outside of the cylinder and ground smooth. The outside diameter can be got by trying the cylinder into the spaces between the teeth. No polish need be done to the outside, only grind it smooth. Our cylinder should now be removed from the wax to be hardened. It is well to cut off the end of the piece used to grind out the inside, say at the dotted line *l*, and put it into the recess or hole *i*; a notch can be filed in the end at *j*, to fasten it with fine binding wire to the rest of the cylinder. This plan prevents the thin cylinder from cracking in hardening. In hardening we should use some of the anti-sealing compounds, and these, if filled into the recess of our cylinder, would be difficult to remove after being vitrified, and the plug just described, if only touched at the outer end with some protection, keeps the inside of the cylinder free from scale. After the cylinder is hardened, it shall all be reduced to a dark straw color, and the parts above what is embraced in the dotted line *m*, fig. 3, should be reduced to a dark blue. If any of the substance used to protect the steel parts from sealing in hardening adheres, it can be removed by boiling in water. After the cylinder is hardened, it should be restored to the wax as shown at fig. 1; a pointed piece of peg-wood, as shown at *e*, used to true it up. I should have mentioned, when speaking of turning the outside of the cylinder before hardening, that in case the hole or recess for the outside of the cylinder became, in the operation of drilling and grinding, a trifle out of true, the wax should be warmed and the job trued up by touching the *inside* of the cylinder; and so in truing up after hardening, it is best to true up by the inner surface. The cylinder is now to be re-ground and polished both inside and out. A new plug should be turned like *h*, fig. 3, to grind out the inside, carefully making your oil stone dust very fine. A piece of peg-wood, with alcohol and diamantine, will polish both inside and outside. A plug for the lower pivot should now be fitted, and the pivot turned and fitted. The next operation is opening the cylinder for the scape wheel action; this is best done with a soft steel wheel (*lap*) and diamond dust. At diagram *B** is shown an elevation of a cylinder, and *p r* shows the cut away parts; *p* is where the teeth act. Fig. 4 shows a side view of the soft steel lap, charged on the edge with diamond dust. *F* represents the brass chuck for going into the lathe; *n* a screw for holding the lap; *s* the cylinder. The edge *o* is charged with diamond dust well burnished in. To use this tool the cylinder is left in the wax and the chuck removed from the lathe; the brass chuck *F*, fig. 4, is put in the lathe and the cylinder is held as shown at *s*; and the part *p*, diagram *B**, should be ground away not quite half, and the part at *r* cut

three-fourths away. The cylinder edges where the teeth work should be ground with oil stone dust and a flattened piece of soft steel, and finally finished with diamantine and alcohol. To turn the cylinder in the wax, and turn and finish the top pivot, is too common a job to need further description. If the balance is of gold or German silver, the seat for the balance can be turned of the exact size, *i. e.*, full large, so the balance has to be driven on; or the cylinder can be turned as shown at *D**, *t* representing the balance seat, while *v* is much under cut so as to rivet or close over easily.

Repairing Watch Cases.

[By W. SCHWANATUS, Berlin, Prussia, in *Deutsche Uhrm. Zeitung*.]

I.

DURING the pursuit of my vocation of casemaker for many years, my customers have frequently solicited me to contribute a series of articles on the minor repairs of watch cases, for the use and assistance of country watchmakers, since very frequently slightly damaged cases are barely worth the trouble of being sent to the casemaker. Impelled by these opportunings, I have finally concluded to do so, and I will commence with

Repairing the Pendant.—The soldering of a broken pendant is a job of frequent occurrence. If broken off smooth, which is often the case, it is not necessary to put a piece into the middle part for strengthening. Before attempting the work, take the case completely into pieces. For this, do as follows: Gold cases have generally three pins in each joint, two end pins and one center pin. They are always inserted in the pendant from right to left, and must be returned again in the same manner. When taking the case to pieces, remove the end pins with a graver, which is not difficult to be done. Firmly press the graver into the ends of the joint, and with a small, wriggling motion forward the pin is easily dislodged; it is well to have the graver fastened in a handle, as it offers more firmness in its manipulation. The end pins having been removed, take a well-filed punch, which enters firmly into the joint, while at the same time it must not fit too tightly, since it would widen or burst the latter. It is well to anneal and blue the punch, as it must be the main object not to injure the joints. Then take the case in the left hand as well as the punch, and with a small hammer give a few blows upon it from left to right, and the pin will soon appear. The pins belonging to one joint must be carefully preserved, and returned in the same order.

Have a care that the punch has no burr, and that its point be rounded off; we casemakers set much store upon a good punch, for reasons mentioned. Should the pins be obstinate and refuse to move, strike a few taps upon the end of the joint, whereby this widens a trifle, and the end pins may then be taken out. When out, and the center pin should be inclined to give trouble, it may be treated, in the same manner, to a few slight taps. This trouble to get out the pins is very seldom necessary.

The joint sometimes contains an entire pin, and it must then be pushed out with a flat graver from left to right, by placing the graver at the ends of the joints firmly, and pushing it forward with a strong pressure; for greater security and steadier motion, brace the hand with the case against the working bench. When pressing out the pins do not use a long graver—the shorter it is the greater the power that can be developed with it. If the pin won't budge, widen the joint with the hammer, as indicated above. The pin may also at times be pushed out from right to left, and it occurs at times that a punch has to be brought into requisition.

When the case has been entirely taken apart, inspect it to see that it be not strengthened with pinchbeck in the middle part, or that the pendant be not lined with tin. Unscrupulous casemakers sometimes use pieces of brass for strengthening the middle part, and solder it in with tin. When this is present the novice had best

cease from repairs and send the case to a casemaker, it being too troublesome to the former to remove the tin.

We will presume that it contains none; there is little danger to injure a case by soldering, as 18 or 14 karat gold can support a fair degree of heat, and we proceed as follows: Carefully clean the surfaces to be soldered, and place the pendant in position to see if it or the middle of the case requires bending. When it has been reduced to its former symmetry, take a small piece of stout iron or steel wire, push it through the bow holes, take binding wire and lay a few loops around the middle of the case. Then take the pendant and lay the wire around the iron wire in the bow holes; lay the binding wire again around the middle part and draw it pretty tight, to prevent the pendant from moving. When sufficiently secure, again inspect it that it be in its proper position; then take a piece of slate and a piece of borax, rub this with a little water to a thin paste upon the former, brush the place to be soldered with it, and apply the solder in small pieces from outside, say about in the middle of the middle part. Do not use too much, and at the same time do not place it in the snap of the case—rather direct upon the outer broadside of the middle part of the pendant. With gold cases never use silver solder, but only gold solder. The middle part having in this manner been prepared for soldering, you may again brush the whole with borax.

Next, take a well-charred piece of charcoal and place the middle part upon it. So as to keep it from falling off, place a small iron wire in the middle of the coal and lay the middle part in it. Then solder on the pendant with a small alcohol lamp, with a moderate flame. It is advisable to first heat the solder a little, or to dry the borax, so that it remain in the position in which it was placed, to which attention must be directed. All care must also be taken not to direct the flame upon the object to be soldered, but warm first the middle part dark red, and slowly pass over to the pendant. Soldering must be successful in this manner. If the full flame were directed at once upon the pendant the solder might run into little balls, or "corn," before it has fused, and I would most decidedly counsel not to attempt and fuse these balls. Should it have occurred, let the flame become steady and the object cool, remove the balls and apply other solder in their place. Of course, the repairer's eye must, during soldering, be directed upon the solder, and as soon as it has fused the flame must cease; do not attempt by augmenting the heat to distribute the solder over different parts. As has been said above, there is no need to anticipate the melting, especially of an 18 or 14 karat gold case, by gentle treatment and steady flame; simply do not blow too much. When the solder has fused, let the object cool, and inspect it whether it is to satisfaction. If you find an occasional spot where it has not surrounded the pendant, lay on a piece of solder; should you see a hole, however, put in a piece of brass or pinchbeck, lay a piece of solder over it, and repeat the operation. I would specially remark here that too much solder is injurious. Use it sparingly.

If the soldering has been successful, remove the wires, place the object in a shallow vessel with water, and add from 20 to 30 drops of sulphuric acid, in order to remove the fire discoloration; an excess of sulphuric acid is not hurtful to the gold or silver. When it is found in a short time that the discoloration has been removed, take the object from the pickle, rinse it in water, and dry it clean. Should a little superfluous solder be visible from the outside, seek to take it off with a file, taking care, however, not to deface the shape either of the pendant or of the middle piece. If some has found its way into the snap, take a small, flat graver and carefully cut it away. This manipulation must be performed still more carefully than that of the filing, and if it cannot be removed without injury, it is better to leave a little solder in the snap than to injure the latter—it will do no damage. Then take a thin-cut pegwood and a little pumice stone and water, and grind the soldered place. The other parts of the middle part can be treated in the same manner should they show traces of the soldering. The part is finally brushed with

a chalk brush, to remove the adhering pumice stone, and polished with a pegwood or a piece of cork and crocus and alcohol; whenever the leather buff stick can be used, do so.

The case is now ready to be put together again. When doing this, file the center pin a trifle pointed at both ends, if the old one is used, to remove any burr. Any damage to the end pins, caused when taking them out, is to be removed with a very fine and worn file, after they are inserted again in the joint. The last piece of work is to nicely smooth the joint ends with such a file, for which purpose another case may be taken as pattern. Then polish them with a crocus buff, and the repair is ready and to satisfaction, if these directions have been adhered to. We next come to

Lining Pendant Holes.—The lining of the pendant is an easy job, especially if the case is without spring closing; but even cases with spring closing belong to this class of repairs.

Never line the pendant by riveting in a tube, or, what is still worse, with tin. Both kinds are unknown to the casemaker. When the case has been taken apart, the trouble to line the pendant with gold solder is very small; take no brass tube, however, but rather use pinchbeck; this resembles closer to the color of gold. The holes in the pendant must first be filed uniform with a good file; if they are worn out upward, which is often the case, file them downward; the pendant holes can more properly stand a little further below than higher up, and nothing disfigures a case so much as high pendant holes. When filed out to satisfaction, take the tube and fit it in firmly; take care, however, to have the joint below, and let it protrude a little on both sides. Then solder it in place with borax and gold solder. Cases with spring closing demand the additional attention that the tubes used for lining do not enter too far into the pendant, so that sufficient shake is left for the push-spring, while with cases without them the tube may pass entirely through. This part of the case, after finishing the job, is immersed in the pickle, the protruding part of the tube filed off, and smoothed with a worn file level with the pendant, all care being necessary not to injure the latter. The scratches of the file are removed with a water stone. When this has been done, open the holes uniformly with a broach, and then hollow them out with a chamferer, according to the size of the bow. The middle part is finally polished, and the case put together again.

Work at the Joints.—A skillful workman is known by the joints he makes, and to make a good one is not as easy as might appear at first glance. I will endeavor to explain it as briefly as possible to the watchmaker, to enable him to do many a small piece of work himself, but will preface my remarks by saying that a good amount of skill, alertness and diligence are necessary. Casemakers frequently handle watch cases repaired by jewelers and others, who boast of their ability to repair cases, but, generally speaking, the case is botched, and entirely ruined. I would dissuade, therefore, from giving such a job to a jeweler, if two or three new joints are to be made to the case.

If, as is frequently the case, the middle joint of the case has become loosened, by reason of faulty soldering, take the case apart with flat pliers, bend the loose joint together, should it have opened somewhat, then place it between the two bottom joints, and carefully inspect whether it lies at the same height with them. When this has been set in order, clear the part at the middle piece, where the joint was located. The knuckle may then be placed in the channel, lay the cover on, and see that it protrudes nowhere. The place where the knuckle is to be located must be exactly marked by two lines, and the joint to be soldered is then tied between them. It is to be placed upon the same spot it occupied previously, and pay strict regard to that the slit lie in the middle of the knuckle. The binding wire may be drawn fairly tight. Next apply borax to the middle piece, and let it well run through the middle joint; blow out the excess. The solder is applied both from without and within to the joint, but be saving of it, because very little is required to solder the latter; if much were applied, it may easily happen that the sold

runs into the joint, preventing the cover from closing tight. It is a difficult job to get the solder out from between the knuckles. To insure that no solder run in between, the following process may be employed: Scrape a little chalk, moisten with water, and place it into the knuckle with the point of a broach; this can be done after the middle part has been supplied with borax. The chalk, however, must neither communicate from outside nor within, where the solder lies, with the borax. All the preparations so far advanced, solder on the joint. Before immersing the middle part, after soldering, in the pickle, inspect it closely, to see whether the joint has been soldered securely; if you find that more solder is still necessary, apply it and repeat.

When the job is to satisfaction, and the middle part dipped, inspect the bottom joints; it often happens that they have suffered by the bending over of the bottom, whereby the middle joint broke off. In this case, file a pin of brass or pinchbeck, which enters firmly in the bottom joints; let the pin remain in them, and by means of bending with flat pliers or with a riveting hammer, spring the joints back into their original position, after which, if all three joints are sufficiently strong, they may be broached all together. Do not use an unduly thick broach, and be careful. Should a little solder have run into the middle joint, it may be removed with the broach. For this purpose, place the cover upon the middle part, and with a broach pass through all the three joints.

When bending the bottom joints with the flat pliers, use no sharp one, so as not to injure either the joints or the cover rim.

It happens frequently that from careless opening or violence the joints are simply torn out of their angle, and it is not necessary to solder them. In such a case take off the cover and dust cap, remove the lifting spring, and file a pin fitting exactly into the joints, which is inserted into them. It is then possible, by means of bending and the riveting hammer, to force the joints back into their original position, but be it understood that the pin is to remain in during the operation. It is immaterial whether the bottom joints or the middle one is first restored to its position, only never hammer upon the hollow joint, or try to bend it. When they have been restored to order, that they again open at a right angle, grind them with a fine stone, or with a pegwood and some pumice. If it be found, however, that they cannot in this manner be restored to their former position, and it is desired to correct the defect, take a small piece of *thin* gold or pinchbeck plate, as long as the center joint, and from outside bind it against it with binding wire; it may also protrude a little beyond the joint, not in length but in height, so that the solder can be placed on it from outside. Next apply borax to the plate, as by joint soldering; lay a trifle of solder against it from outside, using as little as possible, to keep it from flowing into the knuckles. The piece of gold plate can be very thin. When soldered in place, and the middle part has been dipped, file that part projecting from outside even with the middle part. Finally, all the three joints may be opened with a broach, and this defect also has been removed.

(To be Continued)

The Aurora Watch Company.

WE HAVE received a copy of the prospectus of the above named company, and as we have some criticisms to make of the same, and do not wish to be accused of any unfairness, we shall quote literally from the document itself, to some extent. In order, therefore, to start fairly, we commence with the title of the company and list of officers, which are given as follows:

"Aurora Watch Company, owned and controlled by the trade. Capital \$250,000, shares \$100 each. Officers: President, Edwin W. Trask; Vice President, Albert H. Pike. Directors: M. Haufman, Quincy, Ill.; E. W. Trask, Aurora, Ill.; Albert H. Pike, Kankakee,

Ill.; Maurice Wendell, Chicago, Ill.; Geo. F. Johnson, Aurora, Ill. Business Manager and Treasurer, Maurice Wendell, Chicago. Superintendent of Works, George P. Johnson, Aurora, Ill.

The prospectus is a very lengthy document. It opens with a laudative of the coöperative system of doing business, and says: "So successful and remunerative has been the coöperation of the dealer with the manufacturer of late years that a careful selection of trade investments has given many of the well known manufactories a scale of profits almost equal to the returns made by the most largely paying speculative investments. This large return can only be obtained where the retailer is in a position to share the profits of the manufacturer, to absorb the profit made by the middleman or jobber, and also secure the last or retail profit for himself. This he can do only by coöperation with the manufacturer, as a stockholder in the manufacturing enterprise." It would be hard to make a statement more opposed to the truth of history than this. As a matter of fact, the coöperative theory of conducting business has been a most lamentable failure whenever undertaken, and we could name any number of instances where the attempt has proved disastrous to all engaged in it. It is one of the immutable laws of trade that there shall be capital and labor, and that the representation of these shall be distinct classes. Labor has frequently assumed that it could get along without capital—or, rather, that labor *was* capital, and has paid for its rashness by lamentable failure. Manufacturing interests are quite as distinct from those of the retail dealer, and the attempt to unite them will inevitably lead, first to friction and then to disaster. Such has been the experience of the past and such it must be in the future, because of the diversity of interest of the two classes.

The statement regarding capital is misleading; did it read, "authorized capital \$250,000," it would probably be correct, but nowhere in the prospectus is it claimed that one dollar of this amount has been paid in. On the contrary, subscriptions to the stock are *solicited from the trade*, and it is expected that retail dealers will take the amount. The projectors of this company doubtless are successful dealers in their several localities, and are, we presume, acting in good faith in this matter, but what one of them has had any experience in the manufacture of watches, or is competent to manage an industry of such magnitude, and that combines so many diverse interests? What watch manufactory, now in successful operation, would trust its affairs in their hands? Something more is required to successfully manage such an industry than a local reputation as a retail dealer; science, art, and the highest order of mechanical skill are necessary, as well as that rare combination of qualities vouchsafed to but few, that go to make up a skillful merchant. We fail to see in the above list one name that is calculated to inspire confidence in the success of such an undertaking, and this we say without any disparagement to the qualifications of these gentlemen to fill every requirement of the line of business to which they have been educated.

Following up the laudation of the coöperative idea, the prospectus continues: "For years past the retail trade has been compelled to submit to the arbitrary exactions and grievances imposed upon it by the monopolies that up to the present time have controlled the manufactories. *Now the trade is united* in bringing about a change that shall enable it to control the sale of the staple which forms the most important and valuable part of the business, and which will also yield the retail dealers a large profit in its manufacture. The result of this feeling and united action in the trade is the organization of the Aurora Watch Company." The first sentence insinuating that existing watch companies are "monopolies," is the veriest bosh, and is a part of the stock in trade of the "commune" that sees a monopoly in every honest industry. Everybody in the trade knows that in scarcely any other branch has there been so much competition as has been waged between the various watch manufacturers, and where active competitors exist there can be no monopoly. It is also a fact well known, that the trade was never better supplied with

watches than at present, nor at more reasonable rates. We would like to ask by what means, and when, the retail trade became "united" to bring about a change, and how, and when this "united action" was taken, that resulted in the "organization of the Aurora Watch Company?" As a matter of fact, there is no such feeling in the trade, there has been no such united action, and the Aurora Watch Company is simply a creation of the imaginations of the few gentlemen who seek to enlist retail dealers in its support. That there has been no "united action," and that the plan of the incipient company, so far from being in the interests of the trade, is diametrically opposed to its interests, is shown by the following extract from this extravagant, and not at all modest prospectus: "This prospectus is sent to you ONLY. You have been selected to become a stockholder and conduct the sale of the goods in your town. Should you desire to subscribe, please fill out the enclosed blank within two weeks from the receipt of this. If, at the expiration of that time, you have not replied, the presumption will be that you do not wish to subscribe, and the next best dealer in your town will be called upon, if the entire stock in the meantime has not already been taken." That is to say, if there are ten dealers in a city or town, one of them will be invited to become a stockholder, and the other nine will be ignored. As an incentive to the one to subscribe, he is offered the sole agency of something he knows nothing about, and that he must accept on faith, trusting to the honesty and capacity of men who know no more than he about what they propose to make for him. The company, instead of being in the interests of retail dealers, appeals only to the very limited number who can be induced to take stock, and proposes to antagonize these few to the great majority of the trade. What an assumption to put this forth as a "trade organization" and opposed to monopoly! But suppose the dealer, to whom this prospectus is so confidentially sent, prefers to keep his money in his own legitimate business to investing it in such a visionary and impracticable scheme, then the option to buy stock and become exclusive agent is hawked about among the other or "next best" dealers. The question of "best" and responsibility are all swallowed up in the problem "will the gudgeon bite? Will he take our stock?" If he does take it, then he is at once raised to the rank of "the best" dealer in his particular locality, and is a fit person, in the judgment of the Aurora Watch Company, to be instrumental in antagonizing his brother dealers, and to be made sole agent for their unborn and unknown watches, and this is the company the trade has *united* in organizing! Suppose half a dozen dealers did get together and determine that this scheme for a subscription—pass-around-the-hat watch company should be attempted, what right have they to assert that the trade has united in its organization? The assumption of the three tailors of Tooley street, who commenced their proclamation, "We, the people of England," was no more ridiculous. But even the scheme of a trade subscription watch company is not original with these Aurora projectors. Our old friend Adams, whom we always admired for his superabundance of cheek, "worked this racket" years ago and often, and with about the same degree of success that we apprehend will attend the efforts of his modern imitators.

The prospectus is full of inaccuracies and misleading assertions, some of which have sufficient basis of fact to make them all the more misleading. But we do not care to follow it through its devious windings, but will simply submit to those who may receive this extremely confidential circular a few questions, which we beg they will consider before parting with their money in such a visionary undertaking: 1. Can you afford to withdraw money from your business to put into a questionable undertaking? 2. What assurance have you that the men who have chosen themselves as officers and managers of this company have the requisite experience, intelligence and capacity to conduct such an undertaking successfully? 3. What assurance have you that they can produce watches any cheaper than you can now buy them? 4. What guarantee have you of the quality of the watches they promise to supply you with?

5. What guarantee have you that they can fulfill any of their promises? 6. How can you expect that inexperienced men, who know nothing whatever about the manufacture of watches, can compete with those old companies that have developed the industry from its infancy, and have been themselves developed in the process? 7. How many of the present successful companies sunk more than double the amount of their original capital before stockholders ever realized a dollar's benefit? 8. Do you desire to throw down the gauntlet to the other dealers in your town, and challenge them to compete with you? Are you prepared for such an antagonism as this pre-supposes? 9. Do you believe that a company organized on this pass-around-the-hat plan can be successful?

Because we have been consistently and at all times opposed every attempt we have heard of to organize a coöperative watch company, and to seduce retail dealers into subscribing to its stock, it has been said that we are in the interests of the old-established companies, and opposed to any new company. This is so far from true that, as our columns will show, we have encouraged every honest attempt that has been made by private parties, employing their own capital, to engage in the manufacture of watches. The field is open to all comers, but we believe that whoever attempts to cultivate it should be possessed of sufficient means and sufficient brains to give some hope of his being successful, and, further, that he should have sufficient confidence in himself to be willing to risk his own money in the enterprise, and not depend upon being bolstered up by the retail trade. We are opposed to every scheme that seeks to inveigle retail dealers into investments that are dependent for their success upon their contributions. We object to seeing them made the victims of any class of visionary men, however honest in their intentions, who appeal to the retail trade to boost them into notoriety, and permit them to ride their hobby in public. There is a demand for a cheap watch of fair quality; the present manufacturers created this demand, but it has increased beyond their ability to supply it. Thousands of moderate priced watches, keeping time with sufficient accuracy to satisfy the ordinary working man, could be sold, and a fair profit realized. If the gentlemen named above as interested in the Aurora Watch Company, or any one else, will start a manufactory with their own capital, and entirely as a private enterprise, to make watches of the grade we have indicated, with a possibility of eventually working up to the better grades, we will give such an enterprise our cordial support, and the retail trade will greet their products with joy. But it is this attempt to work upon the retail trade and to seduce dealers into a coöperative and problematical scheme of this kind that we protest against. If the dealers named above desire to become watchmakers, let them put their money into the enterprise, and openly and above board conduct an independent business, and not seek to hang on to the skirts of the retail dealers. The retail jewelry trade is a distinctive industry by itself, and is as foreign to the manufacture of watches as it is to shoemaking or plumbing, and any attempt to "coöperate" the two will surely prove disastrous. We shall probably have more to say regarding this visionary scheme in future issues; the opportunities for criticism presented by this delusive prospectus are numerous and tempting.

Table Utensils.

[BY JOHN W. MILES.]

Continued from page 205.

THE ORIGINATION of the use of forks in eating is ascribed to the 14th century, and certainly no record of them has been found previous to that time, either in the tumuli or in the ancient writings, if we except the two forks in figure 27, which are placed in the 12th century. (This, I think, is an error, although they might have been intended for kitchen use only at that date and not for the table). They are certainly among the first, if not the first, objects

of this description used by the Europeans, for though the Greeks, Romans and other ancient nations had large forks for hay, and also

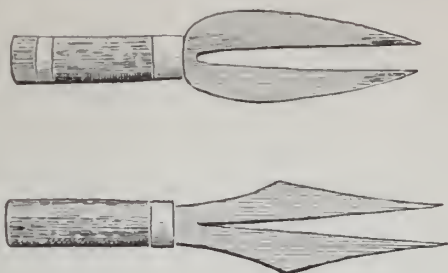

FIG. 27.

iron forks for taking meat out of pots, they had no table forks. There is, however, a fork in use by the Fijians, of an uncertain age, which may have been invented long before the Christian era. These Cannibal forks, figure 28, were made of wood, and were often mar-

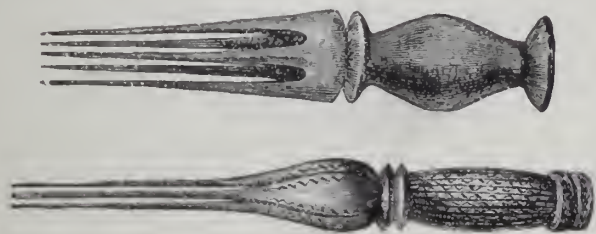

FIG. 28.

vellously decorated, if we consider the uncultured and savage state of the manufacturers. The engraved work was doubtless executed with small teeth, such as those of rats and mice, as we know teeth were used in carving. They were made by the carpenters, who formed a distinctive class or caste of the people, and who constructed their wooden bowls, spoons (figure 11), canoes, etc. The two forks represented here are undoubtedly of great age, and it appears to have been a custom to keep these articles in families for generation after generation, descending as a valuable legacy from father to son. They would eventually become famous and acquire names like a person, and be known by them. The ordinary food of the Fijians (yams, breadfruit, cocoanuts, pig, etc.) was eaten, as in primitive times, with the fingers. The forks were used only in eating human flesh, and hence the term "Cannibal forks" is no misnomer. It is strange that a practice so abhorrent to civilization should have instigated the construction of so refined an instrument as the fork, and when we consider that the Fijians, although rejecting meat that is at all tainted, greedily devour human flesh in an advanced state of decomposition, our admiration for the skill that could produce so delicate a piece of workmanship is changed to disgust at habits so revolting. Let us return to the forks of the 14th century. Previous to this date forks for eating were wholly unknown in European countries. Their invention is ascribed to Italy, although they did not come into general use in that country until the latter part of the 15th century. At first they had but two prongs, or, rather, two long sharp points of steel surmounted with a handle of silver, and were used only in eating pears and some certain kinds of meat. The handles were often very richly and expensively decorated with sapphires and other precious stones. They were very rare, and were kept among the valuables of the possessor carefully enclosed in a case—an article more for ornament than for use. In the inventories of the greatest princes and noblemen of the time there are but few mentions of them, and rarely more than one in the account of a single individual, although there may be several dozens of silver spoons upon the list. According to these inventories Peter Gaveston, favorite of Edward II., possessed sixty-nine silver spoons and three forks; Queen Clémence of Hungary left at her death in 1328 twenty-one spoons and one fork; Jeanne d'Evreux sixty-four spoons and one fork carefully shut up in a box; in 1389 the Duchess of Touraine had nine dozen of silver spoons and two forks of silver and gold; Charles V. of France possessed a few forks of gold with handles inlaid with precious stones,

that were used for toasting the cheese of d'Auvergne, which was afterwards eaten with sugar and powdered cinnamon. These and other records show that the number of forks was limited, and their use restricted to special purposes. The noble metals were extensively employed in the manufacture of both the larger and smaller articles of the household and the person. During the 14th century it was considered a point of elegance among the guests of the grand salons to possess and *publicly use* a small gold instrument having a tooth pick at one end and an ear pick at the other, and these objects are also included in the early inventories. Guests had at the table but one spoon for each person, which they employed for eating liquids, using their hands in eating salads or meat of any kind. Certain rules of etiquette were given out among the *elite* regarding the use of the fingers, and it was a mark of good breeding to soil them as little as possible. With the most delicate management, however, the fingers would become soiled, and the time-honored custom of washing the hands after each meal was observed by them. Accordingly all repasts were attended by servants with basins, water and towels. This ceremony was sometimes performed to the sound of the trumpet, and was surrounded with a considerable amount of ostentatious display, both pitchers and bowls being of pure gold or silver with ornamentation of the highest character. Marguerite, Queen of France, presented her sister Eleanor of Provence a large peacock of silver with sapphires and other precious stones set in the tail. The bird stood in a basin of chased silver, and after meals the fingers were washed in the perfumed water that poured from its beak. It is a little singular in this connection that Cortez should have found a similar custom among the Aztecs. With this race, wholly-unknowing and unknown to the civilized world, cotton napkins and ewers of water for washing were placed before each guest as they took their seats at the board. Amidst some advice on deportment, given by an Aztec father to his son, the latter is punctiliously enjoined not to take his seat at the table till he has washed his face and hands, and not to leave it until he has repeated the operation and *cleansed his teeth*. Spoons of silver and tortoise shell were also found in use by the Aztecs, and knives of flint or bronze, but no forks.

At the close of the 16th century the few forks in existence were mostly of a highly ornamental character, having handles of silver and gold surmounted with figures of lions and other devices, figure 29.



FIG. 29.

At this time they were still a novelty at the French court, and their use was very much opposed, as sinful, by the older monks of the French monasteries. Among the English they were greatly ridiculed; one divine preaching against the use of them as an insult to Providence not to touch one's food with one's fingers. Although known in England during the 14th century, they did not come into general use there until the reign of James I. Previously they were objects of curiosity merely and do not appear to have been much used at the table. In the will of Elizabeth a mention is made of several forks inlaid with rubies and other precious stones. She was the first English sovereign positively known to have possessed forks, but although she had several that were presented to her it does not appear that she used them on ordinary occasions. Her majesty's inventory describes them as follows: "*Item* a knife and a spoune and a forke of christall garnished with golde sleightly and sparcks of garnetts. *Item* a forke of corall sleightly garnished with golde. *Item* one spoune and forke of golde; the forke garnished with two lyttle rubyes, two lyttle perles pendant and a lyttle corall."

Thomas Coryat, who visited Italy in 1608, mentions forks in a quaint account of his travels, entitled "*Crudities*," and published in 1611, as follows: "I observed a custome in all those Italian cities and townes through which I passed that is not used in any other country that I saw in my travels, neither doe I thinke that any other

nation of Christendome doth use it but only Italy. The Italian and also most strangers that are commorant in Italy doe alwaies at their meales use a little forke when they cut their meate. For while with their knife which they hold in one hande they cut the meate out of the dish, they fasten their forke which they hold in their other hande upon the same dish so that whatsoever he be that sitting in the company of any others at meale should unadvisedly touch the dish of meate with his fingers from which all at the table doe cut he will give occasion of offense unto the company as having transgressed the lawes of good manners, insomuch that for his error he shall be at the least brow beaten if not reprehended in wordes. This forme of feeding I understand is generally used in all places of Italy, their forkes being for the most made of yron or steele and some of silver, but those are used only by gentlemen. The reason of this their curiosity is, because the Italian cannot by any means indure to have his dish touched with fingers, seeing all men's fingers are not alike cleane. Hereupon I myself thought good to immitate the Italian fashion by this forked cutting of meate, not only while I was in Italy but also in Germany and oftentimes in England since I came home; being once quipped for that frequent using of my forke by a certain learned gentleman, a familiar friend of mine; one Mr. Lawrence Whittaker, who in his merry humour doubted not to call me at table *furcifer*, only for using a forke at feeding but for no other cause." *Furcifer* literally means one who carries a fork, and was applied to Roman malefactors who were condemned to carry upon their necks a V-shaped wooden fork.

One of Beaumont and Fletcher's plays speaks with great contempt of "your fork-carving traveler," and in Ben. Jonson's comedy of "The Devil is an Ass," there occurs the following dialogue:

Meercraft.—Have I deserv'd this from you two for all my pains at court to get you each a patent?

Gilt.—For what?

Meercraft.—Upon my project o' the forks.

Sledge.—Forks! What be they?

Meercraft.—The laudable use of forks, brought into custom here as they are in Italy, to th' sparing o' napkins.

(To be continued.)

The Jewelers' League.

President, GILBERT T. WOLOM.....Of Woglom & Miller.
First Vice-President, JAMES P. SNOW.....Of G. & S. Owen & Co.
Second Vice-President, HENRY HAYES.....Of Wheeler, Parsons & Hayes.
Third Vice-President, WM. C. KIMBALL.....Of H. F. Barrows & Co.
Fourth Vice-President, AUG. KURTZBORN.....Of L. Bauman Jewelry Co. St. Louis, Mo.
Secretary and Treasurer, WILLIAM L. SEXTON.....Of Sexton & Cole.

EXECUTIVE COMMITTEE.

JOHN D. LYON, *Chairman*.....Of Lyon & Hardy.
 JOSEPH B. BOWDEN.....Of J. B. Bowden & Co.
 JAMES D. YERRINGTON.....Of J. D. Yerrington & Co.
 ROBERT A. JOHNSON.....Of Colby & Johnson.
 SAMUEL W. SAXTON.....Of Saxton, Smith & Co.
 CLEMENT B. BISHOP.....Of Carrow, Bishop & Co.

EXAMINING FINANCE COMMITTEE.

CHARLES G. LEWIS.....Of Randel, Baremore & Billings.
 CHAS. G. ALFORD.....Of C. G. Alford & Co.
 GEORGE R. HOWE.....Of Carter, Sloan & Co.

THE JEWELERS' CIRCULAR is the *exclusive* official paper of the Jewelers' League, and has been selected for the publication of all matters of interest pertaining thereto. Letters or inquiries pertinent to its business or purposes, and which might interest the trade or inquirers, will herein be answered. Address *Jewelers League, Box 3,444, P. O., New York*, or the office of THE CIRCULAR.

At the meeting of the Executive Committee of the League, held August 3d, the following 70 persons were accepted as members:

W. H. Thornton, Chas. W. Russell, John Uptegrove, J. E. Tully, Christopher Staiger, Isaac N. Lee, Fred. W. Sauer, Auguste O. Roy, Thos. E. Rogers, Wm. H. Payne, Anton Novotny, Wm. D. Morris, M. Mayer, Martin Marcus, Morris Lissauer, Henry M. Lewie, Chas. A. Liebman, Bernard Karsch, Nathan Kaiser, Adolph E. Kahn,

Danl. W. Johnson, Jos. Herzog, A. Friedenthal, Simon Englander, Francis Deacon, C. L. Crockett, Wm. L. Cook, New York City; John S. O'Brian, Fayetteville, Ark.; Geo. Mechan, Washington, D. C.; Moses Benjamin, J. P. Connelly, Diderick B. Holst, Sam'l Hyman, Wm. I. Kissel, Francis Monk, Chicago, Ill.; G. G. M. Porter, Menlo, Iowa; Chas. O. Rhoden, Anamasa, Iowa; Emanuel Friendlich, Leavenworth, Kan.; Jas. O. Bates, Baltimore, Md.; Osmyn H. Atwood, Chas. H. Clark, North Attleboro, Mass.; John J. Cluin, Lowell, Mass.; Chas. A. Pease, Belmont, Mass.; Chas. D. Towne, Elk Rapids, Mich.; John B. Blickle, Rochester, Minn.; Herman Oppenheimer, Kansas City, Mo.; Edwin G. Harper, Newark, N. J.; Gustav E. Boigs, Elizabeth, N. J.; Marcus Morton, Brooklyn, N. Y.; Anders G. Askling, Albany, N. Y.; E. Berlet, East New York, Long Island, N. Y.; Chas. L. Coombs, Brooklyn, N. Y.; F. A. Fuller, Jr., Jamestown, N. Y.; Louis Hofeller, Buffalo, N. Y.; Gideon T. Pearsall, Brooklyn, N. Y.; J. T. Tohme, Saratoga Springs, N. Y.; L. W. Bailey, Cleveland, Ohio; David Jacobs, Cincinnati, Ohio; Geo. G. Mulholland, Springfield, Ohio; August C. Toepfert, Cincinnati, Ohio; Richard N. Caldwell, Henry Euler, Alex. K. Moore, Philadelphia, Pa.; Hugo A. Boehme, N. J. Ashton, New York City; Washington J. J. Schultz, Philadelphia, Pa.; Jos. J. Sweeney, Houston, Texas; G. E. Nohn, Richford, Vt.; Hugo Fischer, Lynchburg, Va.; Alex. B. Odell, Coaticook, P. Q.

One rejected, and nine (9) were referred for correction and investigation.

Twelve requests for changes of beneficiaries were granted.

Treasurer reported balance as follows:

General Fund, \$3,345.60.

Benefit fund, with assessment No. 20 not all paid in, \$4,500.00.

[From Our Special Correspondent.]

The National Exposition at Zurich.

ZURICH, July 28, 1883.

Mr. Editor.—I mentioned in due time that a national exposition of home productions would be held at Zürich, Switzerland, to commence on May 1, and close on October 1. Since all foreign competition was naturally excluded in a home exposition, we are sorry that we cannot score new victories for American manufactures. Let us be magnanimous, however, and permit them to chuckle over their own greatness, until brought face to face with American products, and then—

It is well known that Zürich, the capital of the canton of the same name, is situated at the point where the Limmat issues from the Lake of Zürich, and unites with its tributary, the Sihl. Its population in 1870 was 21,199. It is one of the most prosperous manufacturing and commercial towns of Switzerland; yet the narrow streets and lofty houses of its older quarters, on the high ground east of the river, give it the quaint appearance of a mediæval city. It contains many interesting buildings, the most remarkable being the Cathedral, erected in the eleventh century. The University, the Gymnasium, and the School of Industry have long enjoyed a high reputation. The town library is extensive, and numerous museums of natural history, etc., indicate the intelligence and cultivated tastes of the population.

The Zürich Exposition is composed of three parts.

1. The industrial division with its annexes of fishery, hunting and forest is upon the right bank of the Sihl, in the immediate vicinity of the railroad depot.

2. The division for machinery and agriculture is upon the left bank; in this division are also included the divers branches of the iron industry, locksmithing, heating arrangements, armory, etc.

3. The art division, situated at the opposite end of the city, near the *Tonhalle*, contains the collection of paintings by Swiss artists, as well as one of antiquities pertaining to Switzerland.

The impression made upon the visitor by this first great Swiss

exposition is truly overpowering. The Central Committee has discharged its duty in a most masterly manner, and conquered all difficulties; wherefore, it is fully entitled to the highest encomiums of the nation. The greatest attraction for visitors is, of course, that part of the exposition containing the large treasures of gold and silver, silk and cotton, and all the necessities and luxuries of daily life.

The main building for the productions of industry, is a three-aisled construction of about 7,000 square meters (75,350 square feet). The two side aisles are lighted by sky light, the main aisle from the sides. The light is agreeably toned down by means of impregnated, fire-proof white cotton fabric. The center of the edifice is built like a cupola, and contains groups 12, 13, and 32, horology, bijoutry and scientific instruments. The main entrance is near these groups; a very handsome fountain plays in front, and is surrounded by flower beds.

Let us enter into the Hall of Industry through the main entrance. We come first to group 6, clothing; next to group 1, silk; and we see at some distance ahead of us "Horology;" while we make our way toward it, on the left side of the middle aisle, to the section of horology, we come first to a side room, in which the horological school of Geneva is installed. It is fitted up with all the paraphernalia and utensils, as well as drawing and escapement models of watches; various works of pupils are displayed in its showcases, from the most simple blank movement to the finished complicated repeating watches and chronographs.

The catalogue enumerates 290 exhibitors of horology, the greatest majority of which, of course, expose watches. Regulators, mantel and tower clocks are rare; the same is true of machinery and utensils. Files, cases and single parts of watches, many of which of a most excellent device, are more frequently seen. The various horological schools have also participated.

Our readers would soon be surfeited should we attempt to describe every showcase we meet in our stroll, and we, therefore, will only speak of a few noteworthy articles and firms. We leave the room of the Geneva horological school, turn around the left corner to stop before the cases of Mr. Hugentobler, of Weinfelden, where we find a watchman's control clock, which possesses the great advantage that it reports the tardiness of the night watchman, not to-morrow morning, but instantly at the time of the negligence of performance, by ringing a bell in the superintendent's room, so that he may arise in the night and ascertain the reason of the non-performance. We pass on, and turn to the left into the side aisle where the horological school of St. Imier has exhibited its ingenuities. Its escapement models (*gangmodelle*) are very fairly constructed and comprehensive for the learner. Creditable drawings of escapements, pinions, depthings, and the thousand and one intricacies of horology made by pupils, are bound in pamphlets and open for inspection. We ascertain that a pupil finishes the first year three movements from blank works, and completes thirty-three of the latter; in the second year thirty-five anchor escapements, and in the third year forty-eight adjustments and regulatings, fifty flat regulatings, and a number with Bréguet springs. We express our encomiums and a God-speed to the noble enterprise, and passing to the next case we halt at those of

Herr Leuenberger & Sohn, who exhibit three seconds regulators, beside many other mantel clock movements, one of which is a veritable marvel of beauty; its rate is one month. I would call the attention of your readers to the third one, with half-second pendulum, pointing seconds.

Herr Keller, of Aarau, also exhibits several regulators with grid-iron pendulum. It does a watchmaker's heart good, indeed, to see such highly finished and exquisite work; it is an evidence that we still have able masters in Switzerland.

Before us in the left aisle are a quantity of showcases coming from the Bernese Jura, several from Neuenburg and Freiburg. They contain the current article, and we pass them by without inspection.

The blank movement factories of Pruntrut, Münster, Kosière, Reconvellier, Biel and Sonceboz are represented here, especially the latter, which provides blank movements to the majority of the manufacturers of Biel. I annex an interesting statement from their catalogue of the price of blank movements from 1848 to 1883. In 1848 the dozen cost twenty francs; 1879, ten francs; 1881, fifteen francs, and 1883, eleven francs. Adjustments cost on an average ten francs per dozen. These are starvation prices indeed, and are possible only by division of labor in factories.

It struck me as something remarkable that in the entire exposition only one manufacturer of pinions could be seen. A member of the jury answered my question that although vast quantities of pinions come from Savoy, still, Switzerland contains various factories of the kind, but that especially the one exhibiting was most thoroughly arranged for the work, and it could in a very short time manufacture thousands of gross beside the stock on hand.

The material and watches exhibited by the firm Alcide Droz & Sohn, in Biel, were most interesting. They manufacture their watches from the blank movement. Several bridges were shown us stamped out so nicely and smoothly with a machine, that it required only a few strokes of the file to finish them. In order to demonstrate the excellence of their watch cases two watches, which are wound every day, lay ticking away in a basin of water.

The large silver thirty-six line watches, richly decorated, of Gieser, of Tavannes, which find a ready market in Spain, are very showy timepieces.

An opposition to these monster watches was exhibited by Richard, of Locle, a neatly finished anchor movement of three lines. It is exposed in the show case of the horological school of that place.

The factory of Montillier, near Murten, exhibited in several showcases a great variety of watches in celluloid cases, destined for shipment to South Africa. What a parti-colored lot! The ecstasy of the Negroes, Zulus, *et id omne genus*, over the tasty tickers is better imagined than described.

Several horological branches are well represented—screws, case decorations, hands, together with the stamps wherewith they are manufactured, a handsome assortment of pendulum studs for Bréguet springs, a varied collection of anchors, all by A. Huguenin, of Locle. Opposite to these cases we find those of the horological schools of Chaux-de-Fonds, with an exceedingly rich and varied collection. It would be a sin of omission should I forget to mention the anchor model of M. Favre-Bulle, of Brenets, constructed in strict conformity to the directions of Prof. Camille Calame; it is the handsomest piece of workmanship in the entire exhibition, and it was sold at a thousand francs on the next day after the opening. It is truly a marvellously fine piece of construction.

When we turn around the corner near the school exhibition of Chaux-de-Fonds, we enter into a sort of side room, in which Herr Mäder, of Andelfingen, exhibits two town clocks. One is provided with the remontoir system, by which the minute work has no influence whatever on the rate of the clock.

The other part of the room contains watch materials and utensils, files, screws, screw plates, rouge, diamantine, charcoal, lathes, depthing tools, etc., of Favre & Fils, of Boveresse; also universal turning tools, pivot-polishing machines, etc. The watchmaker who is acquainted with the beautiful, delicate, and very ingenious machines and utensils manufactured and used in Switzerland, will be sadly disappointed at their almost utter absence from the exposition. It is especially in this branch, where the country's refusal to adopt a patent law, is most keenly felt. I could mention several large firms which intended to exhibit their best, but they wisely concluded to rather stay at home than see the fruit of their study filched before their very eyes, without one iota of redress.

The firm of M. Droz-Jeannot Fils have adopted a very practical protection against this stealing of ideas. In their glass case lie exposed various medals, both French and German, for inventions and improvements of watches, together with a French patent for 15

years, while the wooden models of said inventions were carefully inclosed in *étuis*, and visible only to the inspection of the jury.

We come to another part of the Canton Neuenburg, and find in their cases watches for "a penny a grab," as well as the finest kinds made.

We now have arrived at the end of one side, and turn around to inspect the other, where, at the very outset, we are struck by the works of two engravers. One is M. Gaberel, of Locle, who exhibits small dies; the other one, the celebrated Besançon, of Chaux-de-Fonds, who exhibits a number of sketches and designs for bank-notes. In spite of the eminent skill of these two artists, the high *Bundesrath* concluded to have the country's bank-notes engraved in a foreign country. We next come to Paul Courvoisier, of Chaux-de-Fonds, with watch cases, etc. Near by is another one, with 5 very flat gold key-winders (about the thickness of a 5-franc piece). I passed with a smile by these old monuments of a by-gone age, when a friend of mine whispered to me, "Do you know that old man who exhibits those watches?" I replied "No," when he told me that that was Salvain Mairet, the most skillful watchmaker in all Switzerland. He is a modest-looking old gentleman, dressed in a suit of linsey-woolsey, and a black felt hat on his head. Subsequent inquiries confirmed the statement of my friend, while one ventured to bet that Mairet could regulate to precision the affairs of a broken Western wild-cat bank. He only lately finished a watch which had been ordered of him twenty years ago. To honor him, the jury commenced their rounds of awarding at his stand, and it is more than probable that the modest and amiable old gentleman will not come off second best at their hands. All honor to true merit.

Near M. Mairet we find an M. A. Pattey, from Les Pont-Martel, exhibiting gold watches, and, together with him, Messrs. Sandoz Frères, of the same village. He who knows this celebrated watchmaker village, knows that *only* excellent watches are manufactured there, and many of the movements from this place are sold to Geneva, whence they enter commerce at a high price.

Another current kind is exhibited by Wille Frères, of Chaux-de-Fonds. They are the successors to Roskopf, and have modernized his heavy-style watches. A former workman of the latter, Ch. L. Schmidt, of Chaux-de-Fonds, who worked for many years for the old gentleman, also exhibits the Caliber Roskopf, but expert watchmakers say that they are regulated with painstaking precision.

Together with various gold watches, the Association Ouvrière, of Locle, also exposes a ship's chronometer. It is said that their quality of watches is excellent, although they are not happy in the tasty device of their watch cases.

As might have been expected, Alfred Jürgensen, of Locle, exhibits a line of half and full chronometers and complicated watches.

Your correspondent pauses here to judiciously intercalate the remark that it is exceedingly difficult to write of a lot of self-same objects and say something pointed, beside making use of the stereotypical expressions of "good," "better," "best," and the other adjectives, positive, comparative and superlative. As might be expected, the movements are inclosed in their silver or gold cases; these, in turn, in the show cases, which is barred and double-locked, while the key is in the owner's pocket. To arrive at anything like a definite result, under these circumstances, is next to impossible; your correspondent has been promised reliable and valuable data, however, and he hopes to be able to make a final and reliable report in your next.

JAN.

Practical Treatise on the Adjustment of a Four-Jewel Cylinder Watch.

[First-Prize Essay by HERMANN HORMANN.]

Continued from Page 203.

25. The regularity of the motion is examined next by slowly conducting the balance with a thin pegwood so that all the fifteen teeth of the scape wheel drop upon detent, paying particular atten-

tion at what place the tooth drops upon the lips, and how many degrees of lifting this amounts to. The tooth possessing the smallest amount of detent is taken as standard, and the motion is afterward to be arranged in such a manner that this particular tooth obtains full detent. The preliminary investigations of the escapement are now ended. Further examinations can be made only after the scape wheel has been uprighted, or at least has been taken in hand.

The mainspring is next let down, and the cylinder carefully taken out. It is advisable to support the balance spring with a pegwood, so that it is not drawn out too long.

26. Attention is then directed to the train. The function of the latter is to transmit the power of the spring to the escapement. With a correctly constructed watch, the proportions of size of the train should, from the barrel forward, decrease at a ratio proportioned to the decrease of the power. This is obtained by making the wheels smaller and lighter, while the friction is diminished by thinner pivots. Should a watch have been spoiled in its construction, the adjuster will, in the rarest of instances, be able to put it into anything like a passable condition. A defect often met with is an unduly large scape wheel, whereby it scrapes on the leaves of the fourth pinion.

27. When inspecting the train, we must seek to form a judgment on the position and height of the wheels to each other, and to the depths. To obtain this, pass the depths through by the touch, and try their shake. Next inspect whether the wheels are mounted straight, whether they have end shake, what is the width of the pivot holes, whether wheels scrape or are liable to, and in what manner these errors can be improved by setting the wheels straight.

28. I start from the basis that every workman, before he undertakes a repair, must definitely know in what manner this is to be performed, and have a clear understanding of the nature of the job, what is to be done to it, and what is the most practical way for doing it.

When the train has been inspected, the bridges are to be taken down, and all the wheels removed up to the center wheel, so that this is alone in the movement, together with the barrel. When taking down the wheels, it is important to observe whether they sit upon the pinions.

Next take down the click spring and investigate the depth, by pressing the center wheel with a pegwood, and observing it from below.

29. It is indispensably necessary to have a clear understanding at the present time, when about to commence operations, whether the barrel can be left in its actual position, or whether, in order to prevent scraping, either the latter or the center wheel has to be placed higher or lower, or whether the latter scrapes on the barrel bridge near the ratchet wheel.

Should the foot-pins be found too long, when taking down the barrel bridge, and be troublesome, therefore, so that the center wheel is apt to become bent, they must at once be shortened to their actually necessary length, and rounded off.

When click and stop work have been inspected, the repairer will have arrived at a clear judgment on the shortcomings of the movement, and know exactly what is to be done to it, and where help is best applied.

THE CENTER WHEEL.

30. The entire watch having been taken down as far as the center wheel, this is left for a while in the plate, and investigations are directed to ascertain whether the plate revolves round, which is done by fitting a suitable turning arbor in the canon, or using the center staff for the purpose. Every wheel must stand straight in a watch, unconditionally so the center wheel, because, beside the scrapings under the bridge or upon the barrel, the rising and falling of the hands created thereby provokes many errors. There are watchmakers who probably mount the minute wheel oblique, in order to insure a passing of the hands over the seconds circle. This method was excusable with the very flat watches years ago, but is entirely impermissible with their present construction.

31. Next examine the width of the pivot holes, the shake of the wheel between bridge and plate, as well as the length of the pivots, whether they protrude sufficiently, or whether the lower one protrudes too far, whereby the minute cannon is placed too high, and there is danger that the minute wheel might pass underneath, (Art. 122.) The wheel is next taken down, and pivots and shoulders are cleaned.

32. In exceptional cases only are the pivots of the center pinion in a sufficiently good order that they may be left in their actual condition. Should they not be round, which may easily be seen, they must be made so by turning them, if sufficiently thick, upon an arbor or between male centers of the tool; the latter especially when the lower pivot is too long and must be shortened accordingly. This work is to be done gently and carefully, especially when the pivot is thin, so as not to weaken it unnecessarily, and, when finished, a few strokes with the polishing file suffice to give it a handsome polish.

33. The majority of watchmakers use, for polishing, the pivot polishing file; in order to use it successfully make brass centers with bearings for the turning tool, at an even height with an eccentric counter center, two on each side, so that three centers suffice to obtain twelve bearings of different dimensions for the center wheel pivots. Then place the pivot to be polished, inserted upon a turning arbor, into a suitable bearing, so that the polishing file barely takes hold. Three pivot polishing files are to be used for the purpose, the first of which is to be ground with coarse emery, the second with that of average grade, while the third is ground with oil stone powder. The first file does for giving the pivot a smooth surface, whereby the file with cut may be entirely dispensed with; the second is used for polishing, which operation is finished with the third. It is not said that files Nos. 1 and 2 are to be used for each pivot, No. 3 suffices when the latter is approachingly good. (Many watchmakers, in fact, possess only one such file, and obtain this object also.

With pinions of a moderate temper, such as are generally found in our present watches, these files render excellent services, and really respectable looking pivots are obtained with them without unduly weakening the latter.

34. Another method consists in placing the wheel and pinion upon a true running turning arbor, which is fastened between the centers of a turning tool, after which the pivot is ground well smooth with an iron grinding file, which is to be bent a little toward the side of the shoulder, and must be sharp, after which the pivot is polished with the same kind of a file and crocus or diamantine.

Attention must be paid to hold the file flat against the shoulder in this operation, otherwise an arched, instead of a flat, sharp shoulder might be produced. With pinions with short shoulders at the wheel, pay attention not to injure either the polish or the gilding with the file.

35. The handsomest and best polish is imparted to the center wheel pivot by placing it into a depthing tool arranged for the purpose in the following manner: After having provided its movable part with a jaw to fasten it in the vise, the side spring of the tool is taken off and replaced by a weaker one, say a watch spring, which must only exert a gentle pressure. The wheel, which has been placed upon a turning arbor, is then inserted in the easily movable points of the tool, while between the other two points an iron disc, specially made for the purpose, is fastened, on which a pulley for the drill bow is mounted. These points are not screwed on, but kept together with a curved piece of steel wire over the outer points of the tool, which, by means of its springing proclivity, also holds the disc between the points. These points themselves must move freely, so that it is possible to pass the bow to and fro, and with it the disc upon the object to be ground or polished. The disc must be turned in such a manner that only a very little tapering cylindrical pivot can be produced. Drilling bows are next placed upon the pulley of the turning arbor, as well as upon that of the disc, in such a manner that opposite

rotations may be obtained. The edge of the disc is provided with oil stone powder, and, by means of the set screw, both parts are brought together, setting the bows into motion with the right hand, while the left gently applies the disc against the object to be ground, and against the shoulder. When the pivot has been ground well, the grinding disc is removed and substituted by a composition disc, which is provided with a little ground crocus or diamantine, and the process is repeated. By a few strokes of the bows, the pivots are polished in a manner that leaves no room for further desires.

It is necessary to state that by this method the turning off of the pivots can be dispensed with, and that the composition disc is sufficient without previous grinding.

36. When the pivots have been polished faultlessly, the holes, both in the plate and the bridge, are cleaned, the wheel is mounted, and the width of the holes tested.

37. Many watchmakers have the habit of bushing the holes of the center wheel. According to my opinion, this is not indispensably necessary if the wheel hangs straight, the hole be not unduly large, and is smooth within; also when the pivot contains sufficient metal it may be left as it is, without committing a sin of omission.

38. When the adjuster is not inclined to bush the hole of a wheel whose holes and pivots are otherwise in good order, but which hangs a trifle to one side, he may correct the error in a very good manner as follows: Slightly open the foot pin holes of the bridge above the plate, with a three-cornered broach, screw the bridge upon the plate and slightly loosen the screws again; then set a brass or wooden punch upon the opposite side of the bridge, toward which it is to be moved, and give slight taps upon the punch until the wheel is well uprighted.

It will, in most cases, be indispensably necessary to file the screw holes in the bridge a little elongated, especially if they are fully tight for the screws.

Above method cannot in all cases be recommended, especially not for fine watches. The best and only reliable way is always to bush the holes.

39. If the bridge is provided with foot pins only upon one side, the center wheel may also be uprighted by drilling in a foot pin upon the other side in the following manner: Mark the limits of the bridge with crocus, take it down, in the center of the space from the screw drill a hole into the plate, as far as the bridge has been marked, mount the center wheel and screw the bridge in place; let the plate revolve and mark the high place. Next drill from below a hole into the bridge with the same drill, to about three-fourths of its thickness (do not drill it through), drive a round pin in and file or otherwise open the hole a little toward the high place of the plate, in case the foot pin should still pinch. With a little practice the adjuster will fully obtain his purpose, and at the same time give more solidity to the bridge.

40. The center wheel holes are bushed in the following manner: Broach the hole in the plate from within for a not unusually large bushing, remove the burr out of the hole from both sides, and file a few notches on both sides around the hole with a three-cornered file; these notches are for securely retaining the bushing, and to prevent it from turning, when subsequently chamfering the hole. A bushing of well hammered sheet brass, or what is still better, aluminum bronze, is to be used; it is broached until the pivot fits in scant, after which it is turned upon an arbor to a correct size and length of pivot. It is then pressed firmly into the hole, and a few taps with the hammer will suffice to fasten it completely and rivet it. The hole is then opened with a very fine broach, which is to be as little tapering as possible until the pivot fits in. It is still necessary to state that the lower center wheel hole is always to be bushed upon the center of the plate, even if it should not be placed there; only weighty reasons can ever prevent this from being done.

41. If the bushing protrudes somewhat and lessens the shake of the wheel, it is to be turned down upon the tool, paying attention to not remove beyond the quantity necessary for the pivot shake; the

other side is to be turned in the same manner if necessary, that the pivot reaches through sufficiently, paying attention to the end shake of the arbor.

42. The bridge is next screwed upon the plate, which is fastened upon the universal turning tool so that it runs exactly round, by centering according to the lower hole, and, with a tapering graver, the upper hole is opened suitably for a bushing, and it is then also bushed in the same manner as described for the other hole. The plate with bridge is then again fastened in the clamps of the turning tool, and this hole also is opened sufficiently until the pivot enters scant.

43. The plate is then removed from the clamps, the center wheel bridge taken down, and the hole is carefully broached. When the shake of the wheel has been sufficiently arranged, the latter is mounted, and by letting the plate revolve it will be found that it runs perfectly true; consequently that the wheel sits entirely straight. A little sink for the collecting of the oil is finally made with a countersink. In many instances the shortness of the pivot and the consequent shortness of the hole permits only an insignificant sinking at the edges of the hole; this should not be omitted, however, in order to avoid the burr.

44. The two holes may also be bushed without the use of the universal tool to upright the wheel. For this purpose the bridge is screwed upon the plate and the two holes are broached together, taking pains, however, to always keep the broach in such a position that it passes truly vertically through the plate, else it is broached from both sides, revolving the broach together with the plate from time to time; the two holes are then bushed nicely, after which they are broached sufficiently from both sides, without mounting the bridge, that the pivots fit in scant, after which it is only necessary to give them their requisite dimension from within.

45. The suitable end shake is given by means of the chamferer or by inserting a pegwood through the hole in the bridge or plate, fastening the pegwood in the vise, and cutting off its protruding end with the nippers. The protruding pegwood is now split with a simple chamferer made for this purpose, and placed with a gentle pressure upon the protruding bushing. By turning the object, it is easy to remove sufficiently from it by chamfering that the pivots protrude sufficiently, so that after mounting the center staff and canon pinion, the shake of the wheel be not contracted. A very handsome and smooth face is produced by a judicious use and good grinding of the chamferer, in fact, one which is not inferior to that produced in the universal tool. In shops which have not the latter tool, the above given method by means of the chamferer would undoubtedly be the quickest.

When the center wheel holes have been bushed, and the wheel uprighted, also the shake regulated, the barrel is taken in hand.

CHAPTER V.

TAKING DOWN THE BARREL.

46. Watches with bridges contain two kinds of barrels, differing only according to their manner of fastening. The first is that with double bridge and loose ratchet, in which the spring arbor is supported both above and below, by moving between two bridges; second, that which, with its fixed ratchet (since barrel arbor and ratchet consist of one piece), is retained in the barrel bridge by means of the little cap and three or four small screws.

47. Many watchmakers work in another routine than the one laid down here, by removing the barrel at a time before they have taken down the escapement and the train. It is more practical, however, that attention is bestowed at the time of taking down how the depthing is conditioned, and whether the barrel or the center wheel is to be placed higher or lower. When the watch contains a double bridge, such alterations are connected with greater difficulties, for instance, in case that the depthing be too shallow, that the barrel stand oblique, etc.

48. The male stop is now carefully taken down from the barrel arbor, paying attention, should it sit right firm, not to injure the

cover with scratches. This can very well be avoided by inserting two brass screwdrivers from both sides under the stop, whereby it is always loosened, no matter how obstinate it may sit, after which it is easily lifted off.

49. The spring is next to be let down, wound again in order to see how many coils lay around the core, and when letting it run down be very particular to observe whether this occurs without friction; should it rub it would be an indication that the spring is too broad, or that the inner faces of the barrel are rough and insufficiently turned out.

50. The spring is then taken out of the barrel, the cover is fastened again in place to examine the shake of the barrel and the size of the holes, whether it run true or stand oblique, whether it scrape in the sinks or at the center wheel bridge, or at the click-spring, the shake of the barrel and the width of the holes.

When these several points have been well inspected, the barrel is taken to pieces, and the click work taken in hand.

CHAPTER VI.

THE CLICK WORK.

51. Before unscrewing the cap draw on the screws to see that they fit well. If this is not the case, replace the unsuitable ones by new. Examine whether the barrel arbor, with its ratchet, shakes in the sink; should it not go entirely steady, correct the sink by turning upon the universal tool, upon which the cap is screwed, or turn the latter itself sufficiently upon a turning arbor until the ratchet moves with easy friction.

52. The adjuster will know, by reason of the preceding inspection, whether the barrel stands straight or whether it is to be placed higher or lower.

If the barrel with fixed ratchet stands oblique, and is to remain at its actual height, the bridge is screwed upon the plate, and from the sink for the ratchet is turned, upon the universal tool, just enough that the graver barely touches the gilding or the metal at the lowest place.

53. If, however, the barrel is to be set lower, and the thickness of the bridge prevents it—and only in this case—the sink is turned somewhat deeper. That for the cap is to be turned accordingly so that the ratchet moves steady and with moderate friction within it.

54. Special care must be paid to the tothing of the ratchet, that it be slightly chamfered, and that no sharp burr occurs, either upon the upper or upon the lower sides of the teeth, which would operate like a cutter at the cap and in the sink when winding, and render the position of the arbor insecure.

The sharp corners of the ratchet teeth are removed with an oil stone by fastening the spring arbor in a pliers of the screw head polishing tool, and grinding it with a Mississippi stone, or using the filing wood as support in grinding.

55. If the space between the barrel and the bridge is very contracted, whereby the barrel is exposed to scrapings upon its surface, the click spring is filed or ground a little smaller from below, and rounded off. Also the bridge, in case it be sufficiently thick, may be weakened, and the place be rendered nice with an emery wood or water stone.

(To be Continued.)

Sight.

WHAT THE OPTICIAN SHOULD KNOW ABOUT OPTICS.

Based upon an extensive hospital experience in Austria, Germany, England and New York. By C. A. BUCKLIN, M. D., New York. Author of Detection and Correction of Visual Imperfections, Cause and Cure of Cross Eyes, Effects of Color on Distance, and Monograph on Astigmatism.

Continued from page 211.

From some enquiries I receive I concluded that many of our patrons do not clearly understand what we have tried to make plain in THE CIRCULAR.

I will attach a visual test below, with full explanations, and would advise that it be mounted on a card and saved for practical use.



If a person is under forty, and cannot read these letters at ten feet, he is *near-sighted, astigmatic, excessively far-sighted*, or has some disease in his eye—which is the trouble?

1. If he reads fine print at night with comfort, and cannot read the above block letters at two feet, he is near-sighted. You at once give him the weakest concave glass through which he obtains the most comfortable distant vision, testing each eye separately.

2. If he can read the block letters at ten feet, but has trouble in reading fine print, you are justified in giving the strongest convex lenses through which the block letters can possibly be seen. Children who are beginning to look cross-eyed should also be given the strongest lenses through which they can possibly see the block letters at ten feet.

3. If the distant letters are indistinct, and there is also difficulty in reading fine print, the attention should be called to the radiating lines at ten feet. If these do not all appear equally black the person has astigmatism, which may be combined with near or far-sight. The factor of near or far-sight may be estimated by the improvement produced by concave or convex lenses. If neither lenses improve the vision, simple cylindrical lenses will be required. When the common lenses do improve the vision, but the radiating lines still appear unlike, common and cylindrical lenses must be combined.

Most of our readers will not find it to their advantage to bother with cases to whom the radiating lines do not all appear equally dark. Send them to some good oculist with whom you are acquainted, and he will return the person to you with a written order as to how the lenses are to be ground. This you can forward to your manufacturing optician by mail, and he will fill the order in three days, thus relieving you of all responsibility and trouble in the matter, and enabling you to obtain the entire profit from the sale of the lenses. It not unfrequently happens that the best experts have to pay for cylindrical lenses which they have ordered, through which the patient cannot see.

4. If distant vision is poor, *near* vision is poor, convex lenses will not improve distant vision, and the radiating lines do not appear unequally dark, you have a diseased or abnormal condition of the eye, which you cannot benefit by glasses.

5. If a person over forty can see block letters at ten feet, but has difficulty in reading fine print, he probably has simple presbyopia. Give him the weakest convex lens with which he can read fine print with perfect comfort. When the block letters cannot be read at ten feet, but the radiating lines do not appear unlike, *very strong* convex lenses are frequently required for reading.

If distant glasses are required when the radiating lines appear equally dark, give the *weakest convex* lenses through which the block letters can be seen at eight or ten feet. It occasionally happens that a person is found who is slightly near-sighted, but the degree of presbyopia (old-sight) is greater than the near-sightedness. Such a person should have the weakest *concave* lenses through which the block letters can be read at ten feet for distant lenses, and the weakest convex lenses through which fine print can be read with comfort. You recognize such a case by the fact that although he wears *weak* convex lenses to read with, his distant vision is poor. If you place a weak *concave* lens before his eye, and distant vision is improved,

you know immediately that you have a near-sighted person whose *presbyopia* (old-sight) is greater than his *myopia* (near-sight).

Where astigmatism is combined with presbyopia, there will be indistinct distant vision, but they will blunder along for years with weak convex lenses for reading, because they have no idea how distinctly other people see; if they once look through a lens which corrects their old sight and astigmatism that is the end of their tolerance of simple convex lenses. They will insist on having lenses like those through which they saw so distinctly; all such cases, when asked to look at the radiating lines at ten feet, will pick out one or two lines which are decidedly more distinct than others. As there is several letters of enquiry to answer, I cannot give the details of how to correct astigmatism in this number of THE CIRCULAR.

NEW SALEM, RANDOLPH CO., N. C., July 16th, 1883.

DR. C. A. BUCKLIN:

Sir:—I wish to consult you in regard to my eyes. I am by profession a watchmaker, having followed the trade for 20 years. I can see well enough to do any work pertaining to the trade, or to read fine print, even by candle light, but cannot tell the time by a clock ten feet off, nor distinguish an acquaintance that distance. I have nothing by which to test my eyes, and ask instructions of you as to how I should proceed.

I have a pair of glasses through which I can see ordinarily well in the distance, but imagine you can improve on them.

Respectfully, W. F. MORAGNE.

If Mr. Moragne should find the radiating lines of this number all equally black at the greatest distance he can see them distinctly I probably could not do any better for him, his case would be one of excessive myopia (near-sight). If they should not all appear equally black I probably could improve his lenses. State how the lines appear at greatest distance you can see them, also how far you can see the block letters without your glasses, and distance you can see them with glasses; would also like to know how lines appear through glasses.

BRATTLEBORO, VT., August 2, 1883.

Please to tell me why my customer, who is about 70 years old, can see with his left eye, with a No. 20 double convex, and with right eye, a No. 11 down to a No. 8 double convex.

This combination suits him best, but cannot find any lens that he can see with right eye as well as he can with left. Any information will be appreciated I assure you. Yours in haste, M. W. F.

Person is *very* hyperopic (far-sighted) in left eye—astigmatic, or has commencing cataract.

If a convex lens improves the distance at which his left eye can read the block letters, he is hyperopic in one eye.*

If with this lens the distant vision is improved, but the radiating lines do not appear equally black, he has astigmatism with his hyperopia, which accounts for the fact that he reads well with a No. 11 down to a No. 8.

The only hope that the vision in the left eye can be decidedly improved, depends upon the fact that the radiating lines look decidedly unlike. In this case a lens might be ground which would improve the eye very much. If commencing cataract, there is no lens that will improve *distant* vision decidedly, and the person has probably seen black specks before his eye.

It is not uncommon to find a person who was born with one eye very far-sighted and the other eye normal.

KENNETT SQUARE, June 25, 1883.

To the Editor of the Jewelers' Circular:

Will you please give, for the benefit of some of the readers of your ever welcome paper, a correct system and description of apparatus used (if any) for selecting and classifying concave and cylindrical lenses? For instance, if I have a lot of mixed up cylindrical lenses, and wish to sort them out correctly, how would the regular optician go about the job? Awaiting your next issue, I am, respectfully yours, CURIOUS.

There is a foreign invention for testing the focal distance of cylindrical lenses; it is not practical, is of little or no use.

Cylindrical lenses always come square with the focal distance

* In high degrees of hyperopia or myopia the acuteness of vision is usually greatly reduced, although proper lenses are worn.

marked in the corner. The first thing to determine is the cylindrical lens concave or convex. Hold it ten inches from your eye, observe some distant object, then shake the lens; if convex, the object will move in an opposite direction to the motion at right angles to the axis of the lens; if concave, the observed object will move in the same direction as the lens. If you have a collection of cylindrical lenses, the strength of which you know, the most satisfactory way is, place such a convex cylinder opposite a concave cylinder that when the axes are parallel there is no motion of an observed distant object; therefore the concave cylinder must have the same number as the convex cylinder which neutralized it. If you are not provided with such a collection of cylindrical lenses, you *can* resort to common spherical lenses. Suppose you have a concave cylindrical lens No. 30; if you observe a line some yards distant, which runs parallel with the axes of the lens you hold in your hand, then when the lens is shaken, the line will move in the same direction the hand is moved. If you place a common convex No. 30, the motion in this direction will be arrested; if you then take a convex No. 24, you will find that the observed line has a slight motion in the opposite direction when the hand is shaken; thus you have detected a difference of $\frac{1}{24} - \frac{1}{30} = \frac{1}{120}$, although the differences are greater as the strength of the cylindrical lenses increase, still, with a little practice, sufficient accuracy can be obtained.

GREENVILLE, N. C., August 1st, 1883.

I have a case of myopia (congenital) in a male, age 26. I have no trial case of glasses, and cannot get his prescription accurately. His nearest point of vision, 12 inches, is No. IV., and farthest, 10 feet, No. XL., of Snellen's Test Types.

If you will send by mail two or three pair of glasses, to cost not more than \$2.50 each, about the number you think required, and if any suit, will return others with remittance. Yours truly,

C. A. SWINDELL.

If the radiating lines are all equal at the greatest distance they can be seen, person would require a myopia of $\frac{1}{20}$ to $\frac{1}{18}$ to produce effect described.

Proceedings of the Horological Club.

A DISTINGUISHED BODY OF WATCH AND CLOCK MAKERS.

One hundred and eleventh Discussion.—Communicated by the Secretary.

[NOTICE.—Correspondents should write all letters intended for the Club separate from any other business matters, and headed "Secretary of the Horological Club." Direct the envelope to D. H. Hopkinson, Esq. Write only on one side of the paper, state the points briefly, mail as early as possible, as it must be received here *not later* than the eighth day of the month, in order to be discussed and reported in the CIRCULAR for the next month.

IMPORTANT IMPROVEMENT IN BALANCE SPRINGS.

Mr. Isochronal wished to call the attention of the club to some very important improvements in the manufacture of Breguet springs, made by Mr. John Logan. That gentleman has discovered a process for hardening, tempering and blueing the springs with exact uniformity. Every one who has attempted to make a Breguet spring will understand the value of this discovery, especially those who have much of such work to do. It will of course be very gratifying to all watchmakers, also, to have such springs for their repairing jobs, as they will be of very superior quality, owing to the method of making them. The principal importance of the improvement, however, is to those engaged in springing or making watches, who need large numbers of springs, as nearly alike as possible in their properties. He had understood that the new springs were to be introduced in the Waltham watches, so that we should soon have an opportunity to test their value by actual trial. He thought, from what he had heard about the process and the excellent results given by it, that we should soon be independent of foreign manufacturers, and that, instead of importing all of our springs, American hairsprings would soon be one of our articles of export. Mr. Logan

was to be congratulated upon this evidence of his skill and inventive genius, and he hoped that his reward might not be entirely in fame, but in something a little more substantial and bankable.

GOOD ADVICE TO YOUNG MEN.

Secretary of Horological Club:

I want to say a word to the young men of the United States who wish to become watchmakers. If you have the means now, you can go at once; if not, save the means; or, if you have a good character and credit, borrow it, and let the one from whom you borrow it pay your tuition, board, etc., *in full in advance*, and buy your ticket for you. I think the very best school in all the world at the present time is the school at Glashütte, Germany, founded by Mr. Moritz Grossmann. Stay three years if possible, never less than two, and then come back and seek a situation in one of our own American watch factories, and work there not less than two years, and better three. It may be that you will like it so well as to stay for life. But during this time you can pay off all you borrowed, with interest. Besides, if you are sensible and diligent all the time, you should have a nice sum in a savings bank, and then you should be able to repair any kind of watch or clock, with credit to yourself and the town, village or city in which you establish yourself, and be a credit to the trade. If all the next generation would follow a course of this kind, and improve all the opportunities offered them, we would never more hear it said, "He is an incompetent workman, to put it *mildly*." Hoping this may be of assistance and benefit to our young men in America, I am yours very truly,

W. F. A. WOODCOCK.

Mr. Uhrmacher thought this very good advice. A young man who had worked for three years in Mr. Grossmann's school would be better trained than most apprentices would be in five or six years in this country. That school is designed and carried on for training workmen, but apprentices here are usually taken for doing errands and cheap work about the store, and the learning of the trade is a minor matter, to be attended to when there is nothing else to do—provided the boss or head workman happens to feel like it, just then. Apprentices nowadays have a slim chance of becoming good workmen, in the majority of shops. It is only when he can find a conscientious man and good workman combined, who is not overrun with business, and *likes* to instruct others, that his training will be worth the time he gives to get it.

THE OLIN PATENT CHUCK.

Secretary of Horological Club:

Will watchmakers who have used the Olin Patent Adjustable Chuck please state how they like them? Are they durable? W.

HOW TO USE BOTTUM'S HAIRSPRING GAUGE.

Secretary of Horological Club:

I thank Mr. McFuzee for noticing my inquiry about the Bottum hairspring gauge; but, as it does not answer to the hairspring gauge I enquired about, I enclose a cut of the one in my possession. You say that the spring should be fastened at the proper place at both ends, and the catch which projects at the side is then moved to the other side, and the strength of the spring is found on the dial, etc. Now, the one I have has no projection on the outside, and no place to fasten the outside of the spring on the gauge. There is a dial beneath the top, with degrees and a pointer, and there are a set of figures and a head with a slot in the center. What the figures are there for I should like to know, and how the outside coil of the spring is to be fastened to it. Perhaps you may be better able to inform me after stating that on the gauge is impressed, "J. M. Bottum, New York," and underneath, "Patented March 13th, 1855."

T. W.

Mr. McFuzee replied that his former answer to Mr. W. was a description of the kind of hairspring gauge he had been accustomed to use, and to see used by others around him, and he thought it to be the true Bottum style of gauge. It was certainly much more convenient to use than the one illustrated in the cut sent by Mr. W., as the latter required that the spring be secured at the center to the center post, and the outer coils held by the tweezers at the point which would naturally fall in the regulator pins. While thus holding the spring, the gauge is turned once around with the other hand, and the pointer then indicates the strength of the spring upon the dial.

Being curious to know which form was really the genuine Bottum's

gauge, he had been to the expense of sending to the United States patent office for a manuscript copy of Mr. Bottum's patent, dated "March 13th, 1855." After considerable correspondence, he received a copy of a patent to Mr. Bottum, dated June 14th, 1859, and was left to *infer* that there was no patent of the former date. At any rate he had not been able to get a copy of it. To show Mr. W. that the foregoing description was correct, he appended the copy of the patent, giving Mr. Bottum's own description and directions for using it. It will therefore be seen that the gauge owned by Mr. W. is of the kind described in the later patent. But what was the construction set forth in the earlier patent he could not tell till he could obtain a copy of it. Mr. Bottum's later patent was as follows:—

Specification forming part of Letters Patent No. 24,366, dated June 14, 1859.

Be it known, that I, James M. Bottum, of the City, County and State of New York, have invented an instrument for the measurement of the contractive and expansive force of spiral hairsprings for watches, which I denominate a "Librometer," which shows the exact power of the spring to contract the librations of the balance wheel.

Before my instrument was devised many expedients were resorted to for the purpose of ascertaining the exact strength of the hairspring—a matter of great importance in watch repairing and rating. Weights and other forces were used to draw the spiral out, sideways, and distend it; but it will be obvious that none of these will denote accurately the exact force of the spring in the direction of the spiral curve, or in the curve in which it is to act.

In experimenting, as heretofore practiced, the spring was very liable to distortion and injury, so as to make a change of hairsprings in a watch a very difficult and expensive operation. My little instrument obviates all the before enumerated difficulties, is easily applied, and at once determines the power of the spring, or any number of coils thereof, with the most precise accuracy, and without the slightest injury to the spring itself. Any number of springs can be readily tested in rapid succession, and their relative powers compared.

The construction is as follows: A dial plate *a*, on which are marked small divisions around the periphery, has a frame or case surrounding it, as clearly indicated in the drawing. At the center of the dial there is an axis or arbor *b*, standing perpendicular thereto and supported by a collar above in a cross-bar or cap piece at *c*, below which there is a spiral spring *d*, one end of which, at the center of the coil, is affixed to the arbor *b*, and the other to a stationary stud. A hand *e*, is also affixed to the arbor, which, as it revolves, sweeps around over the dial *a*; the top of the arbor has a slit cut in it, or any other convenient mode of readily connecting the inner end of a hairspring, which is to be tested, thereto. The mode of testing said hairspring is, to seize it with a pair of forceps or other device for holding, and moving the spring at any determined point thereon, and then revolving it one turn, thus allowing its force to react on the arbor, and turn it together with the index, so as to show the exact power of the spring, in the direction of its natural action in the watch.

Having thus fully described my "Librometer," what I claim and desire to secure by Letters Patent is, an arbor having a measuring spring affixed thereto, together with an index, substantially as herein described, and an attachment for attaching the hairspring to be measured, combined and arranged in the manner and for the purposes set forth, and constituting a ready means of determining the exact force of said hairsprings, as above specified.

J. M. BOTTUM.

Effect of Heat on Balance Springs.

IT IS well for the watchmaker to remember one thing in connection with the effect produced by heat on a metal, viz., that when it expands it does so in all directions. A balance spring, for instance, does not merely get longer when heated; it also becomes

thicker and broader in the same proportions. The reader will be practically familiar with the fact that if he take a number of springs of the same material, of unequal length, but having the same breadth and thickness as each other, and fix them firmly at one end, the long one offers the least resistance to bending through a given distance. If they are equal in length and thickness, but of unequal widths, the widest one offers the greatest resistance to bending. If the lengths and widths remain equal, but the thicknesses are different, the thickest one offers the greatest resistance, and this latter resistance increases much more rapidly than the direct increase in its thickness. It has been demonstrated that the resistance—within the limits of elasticity—of such a spring of rectangular section is "inversely proportional to its length, and directly proportional to its width, multiplied by the cube of its thickness." That is, if we took a spring and doubled all its dimensions without altering its elastic nature, we should find that while the increased length reduced what is generally called its "strength" to one-half, the increased width increased its resistance by the same amount, and that these two altered dimensions exactly counteracted each other, while the effect of the increased thickness being proportional to the cube of that increase, would make our spring eight times as strong as it was before. If heat only produced an increase in the dimensions of our springs, they would become stronger in higher temperatures. We find, however, that they become very much weaker, on account of the remarkable change which takes place in their elastic nature, every increase in temperature being apparently accompanied with a corresponding decrease in the modulus of elasticity.

The effect of the altered thickness and breadth of a balance spring in heat seems generally to be ignored by horological writers. The oft-quoted experiment made by Berthoud, in 1773, is usually the standard of reference. He found that a watch, in passing from 32° to 92° F., lost per day 390 seconds, and attributed this loss to three causes:

Expansion of balance.....	seconds,	62
Loss of spring's elastic force.....	"	312
Elongation of spring.....	"	16
Total.....	seconds,	390

It is not stated how he arrived at these results, nor why the effect of the altered breadth and thickness is omitted. The latter appears to have been entirely overlooked.

The total loss was of course obtained by actual experiment. The losses due to the expansion of balance and to the elongation of the spring were probably calculated with known co-efficients, and may be correct in themselves; but, as the increase in the other dimensions of the spring tended to make the watch gain, the loss of the spring's elastic force must have been much greater than he states.

If we could make our springs of some material which had a large co-efficient of expansion, and a small loss of elasticity in heat, the springs might contain the elements of compensation in themselves.

Problems in the Detached Lever Escapement.

BY DETENT.

TO PROPERLY understand the lever escapement, we must get at the fundamental principles, and master these so thoroughly, that any variation in form will in no way puzzle us, but on the other hand enable us to instantly detect any advantage gained by such change, or loss to be suffered. To do this with due discrimination, we must analyze the different forms of lever escapement in use, and also go somewhat into the *possibilities* of this escapement, if I may be allowed the term. In my last communication I gave the plan of a lever escapement with only one pallet, but this arrangement required twice the number of teeth, or the equivalent zig-zag groove. As probably my readers are aware, the term escapement means a letting go, or releasing a tooth at a time of the train, so that the

hands or indicators shall arrive definitely at a certain point or figure at a precise instant of time. The controlling power or escapement is governed (generally) by one of two principles—the oscillation of a pendulum, or the vibration of a balance and pendulum spring. But the best manner of understanding the principles involved is to first suppose the escapement entirely independent of the train

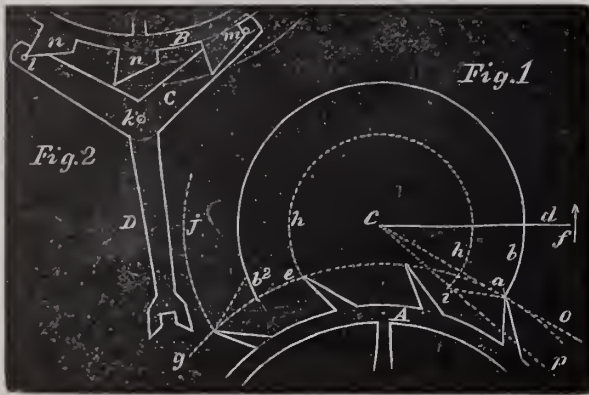

carrying the hands. At fig. 1 is shown an ideal escapement of this kind, *A* representing a portion of a ratchet tooth scape wheel. The circle *bb* we will suppose to be made of thin steel, and extending from *a* to *b*², and embracing two and one-half spaces. We will next suppose this section of a cylinder, *ab*², to turn on a center at *c*, and a lever extend from *c* to *d*; if we now move the lever in the direction of the arrow *f*, the tooth at *a* will be disengaged; but as a portion of the cylinder at *b*² is advanced inside the dotted line *g*, the tooth *e* will rest on the inside of the hollow cylinder *b*². Now, it is evident that if the cylinder *ab* is moved back to its original position, the tooth resting on *b*² will be released, and another tooth advance to *a*, as shown in the cut. In this arrangement we have an escapement, which, if the lever *d* was vibrated back and forth at perfectly even intervals of time, and the scape wheel attached to a suitable train of wheels showing hours, minutes and seconds, it would keep absolutely perfect time. And the problem in hand is to cause the lever *d* to move back and forth, in as near perfect intervals as our skill will enable us to do. As it is impracticable to cause the lever *d* to vibrate back and forth except by some power derived directly or indirectly from the scape wheel, it is well now to consider this part of the problem with particular care and attention, so as to ensure the transmission of the greatest amount of power to the lever; or, it would be better to transmit the power with the least possible loss, as it is evident the less power lost in friction of the train, and in the action of the escapement, the better, as it would require less driving force, (mainspring power) and consequently subject to less wear. It is evident, when the tooth at *a* leaves the cylinder, the tooth at *e* falls to *b*², the wheel *A* moving forward equal to one-half the space of the tooth, this action is termed the *drop*. If now we seek to transmit the power from the scape wheel to the lever, we must resort to some method by which the force of the scape wheel in passing from *e* to *b*² can be utilized; this can be accomplished either by thickening the wall of the cylinder from *a* to the dotted line *h*, or by making the inclined or wedged shaped surface on the tooth, as we see in the so-called Roskopf pin escapement shown at fig. 2, where *B* represents the scape wheel; *C* the pallet arms; *D* the fork; *l, m*, the pallet pins; *n u* the scape wheel teeth. A further description of this escapement will be taken up subsequently. To resume our study of fig. 1: If we draw a circle at the dotted line *h*, just touching the point of the tooth *e* and carry it around to *i*, we will establish the width of the entrance pallet. In order to define one impulse angle, we draw the two lines *o, p*, radiating from *c*, 10 degrees apart. The manner of doing this will subsequently be given, but in this article we are dealing with principles only. Where the circle *h* crosses the line *p* will be the inner angle of the entrance pallet. It will be evident on inspection that as the tooth at *a* passes along the face of our pallet from *a* to *i*, that *a* will arrive at *i*, exactly as *e* arrives at *b*². If we now sweep the circle *h* we can establish the

theoretical position of the egress or exit pallet of a lever escapement of the kind known as pallets with equi-distant locking faces. If circular pallets are required, half the thickness of the pallets are put on each side of the circle shown at *b*. Most of the English lever escapements are made on the plan of equi-distant locking faces; still one often meets circular pallets, and it is of great importance to know *which*, so if any alteration or repair is needed, we shall be able to go at it intelligently. As I said above, the cut at fig. 1 is only theoretical, and consequently has to be subject to certain modifications, and these I propose to give as the articles progress. In my last article I spoke of a wood model; in this I insist, or urge rather, the pupil in horology, to make a brass working model with a scape wheel 5 inches in diameter. With such a model he can easily see the actual working of the parts, as the scale is sufficiently large, and the motion so slow that the action can be perfectly comprehended. As far as the ratchet tooth escapement is concerned, one escape wheel with circular, and equi-distant locking faced pallets, *i. e.*, two set of pallets and one scape wheel, will practically demonstrate any problem in this form of escapement. The pallets are so constructed that the parts representing the jewels can be set so as to represent the jewels as standing at correct and incorrect angles. In the club tooth escapement one set of pallets will demonstrate every principle involved. The model to illustrate every form of detached lever escapement requires only a change scape wheel and pallets, the same arbors for scape wheel and pallet staff being used. The power applied is a weight, and the balance and pendulum spring the same for all the different escapements; a very accurate idea of the relative values of the different forms can be practically demonstrated by this model. For instance, we wish to know which style of lever escapement gives the greatest impulse, and consequent motion to a balance. Here we have equal frictions, the same power (a weight); in fact, all things are equal except the forms of the teeth and pallets; consequently we can study the principles involved with magnified parts, and a motion so slow that the entire action can be perfectly comprehended. Such a model does not require any great amount of time, and the expense is only trifling; but the advantages gained are immense. A pupil who makes an escapement of this kind has the form and impressions so impressed on his memory that he cannot forget them. And the action also is comprehended, as it is slow enough for the eye and mind to analyze them. In fact, let the young watchmaker make and study such a model, and you can in no way confuse him, or lead him astray by any fault or imperfection in a lever escapement. The



general form of such a model is shown at fig. 3. The whole arrangement is fastened to a piece of board 10 or 12 inches wide and 18 inches long. The bridges should be of brass, either cast or heavy sheet. The board can be of pine or cherry ebonized, or, indeed, of any wood that does not readily warp, and should be about $\frac{5}{8}$ thick and well shellaced to prevent springing. The scape wheel is shown at *r*, fig. 3, and is mounted on a staff $2\frac{1}{2}$ inches long; this staff also serves as a spool to wind up the cord for carrying the weight. The scape wheel is held in position by a bridge *g*, while the foot runs in a brass bush in the board *E*. The pallet staff works also in a bridge shown at *w w*, and has a bush in the board *E* for its foot. The fork is shown at *x*, and is of the kind known as the straight line lever. Although, as most workmen know in this day, this form of lever has no advantage except being lighter than any other. The balance shown at *u u*, consists of two weights or balls on the ends of the same, as two balance arms. This form of balance is much more readily constructed, and is in every way as effective as a complete circle, as shown at the dotted circle *G*, if the two balls *u u* are perfectly poised. The balance is

provided with a staff, mounted with roller and steel jewel pin, and has every part of the exact proportions (only larger) which is to be found in a lever escapement in a perfectly constructed watch. At *s* is shown the cock which holds the top pivot of the balance, and at *t* is shown the pendulum spring. In my next communication I will give the correct method of drawing and making the scape wheel and pallets for our model, as well as working drawings for the other parts.

Rings.

IT IS STILL an obscure point in the physiology of the toilet, to know whether women did not commence by ornamenting before dressing themselves. In nearly all nascent communities, the women had, and have still, no other dress than rings, on the neck, wrists, ankles, in the nose, the lips, the ears, and even the cheeks. These are of bird's feathers, little chains of shells, brilliant seeds, colored stones, and metal. From the general uniformity of this custom, from the commencement of all civilization, the ring may be said to take rank as the primitive vestment. Cuvier, who, at sight of a simple jawbone, could reconstruct extinct races, could, doubtless, with more certainty, reconstruct, upon the mere examination of a ring, an antediluvian woman.

It is difficult to fix the epoch, or the country, which first introduced the use of rings. Some attribute it to Prometheus, who, having refused to espouse Pandora, the first mortal woman, presented her with a finger ring, by way of consolation. Pliny, on the other hand, claims that, before the siege of Troy, rings were unknown, giving as a reason that Homer, who names the jewels which adorned the Trojan dames, does not mention rings. This only proves that they did not use them. In the Old Testament mention is made of rings in Egypt, in the time of Joseph, more than six hundred years before the Trojan war.

Be this as it may, before speaking of the ring as an ornament, let us say a word on its different significations.

In ancient times rings bore a symbolic significance, *spirituel* or mysterious; they were sacred, profane, magical—marks of honor or of ignominy—and their material even served to distinguish ranks and conditions. Such were the rings of priests of the ancient law, worn on the hem of their robes, and whose symbolic signification is now unknown.

The high priest of Jupiter, the *Flamendialis*, wore a ring larger than any of his co-citizens, signifying that he was beyond control in any of his functions.

The pastoral ring of our bishop is a mark of their dignity and gauge of their spiritual marriage with the church.

The nuptial ring is the sign of mutual fidelity, which the priest, blessing, puts upon the finger of the wife, saying, "Accept the ring of matrimonial faith." Thus is the ring given to nuns, who take the church for their spouse, etc.

Rings have been also marks of scientific attainments, authority, benevolence, fidelity, nobility, and chivalry. The Rabbi Salomon Jarchi cites, as an article of patrimonial inheritance, the ring, which, in the first centuries, was a mark of honor, power and dignity.

The royal ring, or signet, gave something of sovereign power to the prince intrusted with it. Pharaoh, drawing the ring from his finger, and giving it to Joseph, established him over all his kingdom (Gen. xli. 42). Alexander, on his death-bed, giving his to Perdicas, signified that he was his successor. Mucianus, under Vespasian, bore his master's ring, and, by virtue thereof, conducted the affairs of state, even without consulting the Emperor, if we may believe Ziplien.

Among the Turks and Saracens investiture of office was made by a ring. So under the earlier kings of France, princes and sovereign lords, investing their vassals with fiefs, placed a ring upon their finger, which bore the arms granted to them. Such rings served as the signet, or seal, which took the place of a signature.

At the consecration and coronation of kings the ring is blessed which is put on the finger. In Savoy, the ring of St. Maurice is the mark of investiture of the dukes, ever since Peter of Savoy obtained it from the Abbey of St. Maurice, in Chablais. The Doges of Venice wedded the sea yearly, on Ascension day, throwing a ring into the sea, as if to oblige it to be ever faithful to them, by express privilege of the Pope Alexander III.

A manuscript ceremonial states that dukes received their investiture by the coronet or the ring; marquises by a ruby placed on the middle finger, counts by a diamond, viscounts by a golden rod, and barons and baronets by a banner.

The kings of Persia, in sign of kindness and friendship, presented a ring, and those only could wear it who received it from their hands.

The Incas of Peru placed rings of gold in the ears of those they wished to honor.

In Rome, senators and knights only could wear gold rings. The common people wore them of iron, significant of the moderation expected from them in their habits and manners.

Rings were not only signs of honor; they were marks of ignominy as well. Among many people the ring was a sign of servitude among others a mark of corrupt morals. At Rome, for a long period, to wear two rings was a mark of infamy. Women alone could wear two without being subject to censure.

Rings have been, also, signs of magic power. In old fairy tales and chivalrous romances they played an important part, endowing their possessors with great privileges.

That of the famous Gyges was the most noted of talismanic rings. Its history covers an admirable practical lesson. A learned Eastern scholar tells us concerning it:—

"The philosopher Gylippus first mentions this ring. It was talismanic, but reasonably so, and thus came to Gyges' hands. Gyges lived in Pelopea, about eight centuries before Christ. He was young, handsome, rich, gifted and ambitious. He consulted Gylippus at his home, near Ephesus, as to how he could best use his time and talents.

"Read this every day at the rising of the sun,' answered the philosopher, and he handed to him a *leaden ring*, whose escutcheon formed a plain surface of an inch in diameter, upon which was engraved nine hundred and ninety-nine letters in almost imperceptible characters.

"On his return to Pelopea, Gyges read the inscription, which was as follows:—

"'LOST HOURS.'

"Let us suppose two individuals, one of whom rises at half-past nine o'clock in the morning, the other rises at six o'clock. Of these two persons each lives fifty years; the latter will count sixty-three thousand eight hundred and seventy-five hours, or what is the same thing, two thousand six hundred and sixty-one more days of active existence than the first."

(The inscription proceeds to estimate, in figures, the value of the time thus saved, and the advance in social condition of an active population of a million rising at six instead of half-past nine.)

"Gyges seized upon the sense of this curious calculation of Gylippus. He rose many hours before his fellow-citizens; his labor, his talents, his industry, opened to him a career of distinction; he became an officer, a favorite of Candaule, king of Lydia, and reigned after him.

"Such was the famous ring of Gyges; truly a talisman, as we see but one which may be so to all the world."

After rings as signs and symbols, we have to consider them as ornaments, and how worn. Placed most commonly upon the fingers, they were at first worn indifferently on either hand. Later the left was more used, as being less exposed to action, and consequent loss, than the right. And of the fingers, the one next the least being most used, from the fanciful idea of a special nerve running thence to the heart.

Later still, they were borne on all the fingers except the middle one, which was deemed at Rome infamous. Then came the style of wearing them on the *index*, or right forefinger; and finally they were worn in full *phalanx*, three on each finger. This abuse was restricted by order of the Senate, and none wore rings who did not enjoy a certain fixed income. From the hands rings descended to the feet and ankles, and are still so worn among the East Indian nations; and they mounted to the ears, where they hold their ground among civilized barbarians as well as savages.

From the accounts of travelers we hear of negresses with ear rings six inches in diameter; among the Mongols, a foot in length; while the Malabar women wear them of four ounces' weight, with a hole in the ear large enough to pass a hand through. The Peruvians wore a ring in the nose, proportioned in size to their husband's rank. The ancient Mexicans, Brazilians, and other nations wore rings, stones, bones, etc., in the lower lip.

The luxury and the abuse of rings furnish some curious particulars.

Nonius, a Roman senator, was the first, it is said, to wear a ring set with precious stones. He wore one worth twenty thousand crowns, and was punished by the Senate for his extravagant vanity.

The Emperor Heliogabalus never wore the same ring twice, whatever its value. The ladies followed the lead, and, says Seneca, often bore the prize of two or three patrimonies on their fingers.

Cleopatra's famous act of extravagant luxury is exceeded by Pliny's account of Tolla, the wife of Caligula. "I have seen her," he says, "arrayed for simple visits, having her fingers, arms, neck and ears loaded with jewelry to the value of forty millions of *sesterces*" (five millions of francs).

Juvenal ridicules the Latin fashion of changing rings like garments, with the season.

In one of his epigrams he speaks of "the summer gold, which cools the sweating fingers."

A Famous Diamond.

THE FOLLOWING details of the origin of the famous jewel which adorns the imperial scepter of Russia were furnished me during a residence in St. Petersburg by a descendant of the Armenian merchant who brought the stone to Russia:

The diamond, in its rough state, formed the eye of an idol in a temple near Trichinopoli, and was abstracted by a French renegade, who escaped with his prize to Persia. Here he wandered from town to town, trying to dispose of it for a moderate sum, but only meeting with distrust and suspicion. At length, when the news of the theft had spread over India and reached Persia, fearing arrest, he accepted the offer of a Hebrew merchant and surrendered the diamond for \$10,000. Meantime the Shah was informed, not only of the robbery, but also that the thief was residing in his territory, and had offered the stone repeatedly for sale.

At once his Highness gave orders to arrest the man, dead or alive, and to seize the diamond. The Jewish merchant naturally became alarmed for the safety of his new acquisition, as well as that of his head, and gladly sold the stone to an astute Armenian merchant named Shafras for \$60,000. The magnificence of Catherine the Great and her Court was a by-word in Armenia and Persia, and Shafras knew right well that if he could reach St. Petersburg with his diamond he would be able to dispose of it at a handsome profit. The greatest difficulty was to secrete the stone so thoroughly about his person that in case of his arrest it should not be discovered. It was too large for him to swallow, so he solved the problem by making a deep incision in the calf of his left leg, inserting the stone, and sewing up the wound with silver thread.

When the cut had cicatrized sufficiently to allow the removal of the wire, Shafras began his travels toward Russia. Had he known on arriving at the frontier that the diamond had been traced to the

Jewish merchant, and from him to an Armenian, he would probably have tried to conceal his nationality. But he boldly proclaimed himself an Armenian merchant to the Shah's inquisitive officials, was arrested, and consigned to prison on suspicion. Strong emetics were administered, but no diamond came to light. He was stripped naked, plunged into a hot bath, and then examined from head to foot, with no better success. Even a little torture was tried, but Shafras was firm; and in the end he was bundled unceremoniously over the frontier—his petty cash, however, being retained. He reached Orenburg, and here some compatriots advanced him some money to reach the capital.

Catherine the Great was short of ready money when Shafras offered her his diamond for sale. He demanded \$200,000 for it, but the Empress could not raise more than \$100,000, and though she offered 40,000 dessiatins (at four acres each) of Crown land in addition to this sum, Shafras refused. Catherine was greatly chagrined, and did not hide her annoyance; but she was too noble a character to resort to the coercive measures which a Shah of Persia would have adopted without a moment's hesitation. Shafras was allowed to depart unmolested, and betook himself to Amsterdam to have his diamond cut. Here it was that the famous Count Orlof first saw the jewel for which his imperial mistress had sighed, and he determined to lay it as a gift at her feet. The bargain with Shafras was concluded off-hand, for Count Orlof never haggled. In exchange for the diamond (which weighs 185 karats, and is valued at \$1,500,000) Count Orlof promised Shafras, on his return to Russia, \$350,000 down, an annuity of \$2,000, and a patent of nobility.

The Count kept his word; Shafras the merchant became Lazarev the gentleman, cashed his bills at the imperial treasury, and drew \$2,000 a year the rest of his life, which, as usual with annuitants, was a very prolonged one. Before he died he became one of the richest men in Russia. With the price of the diamond he bought mines in the Oural, land in Bessarabia, and houses in St. Petersburg. The "unearned increment" in thirty years made him ten times a millionaire, and at the present day his descendants, numbering hundreds, are all immensely rich. Loris Melikov, former Minister of the Interior, and Delianov, at present Minister of Public Instruction, are grand-children of the Armenian Lazarev.

THE GREATEST demand for thermometers comes in the depth of winter and the middle of the summer. In the spring and fall, when the temperature is such that nobody thinks about it, the thermometer trade is dull. But it gets brisk in the winter time, when one's nose and ears get frozen, and the water turns into ice in your bedroom. The cheap thermometers that we sell are made in this country—New York City, Troy, and Rochester, N. Y., Chicago and Cleveland. The finest—that is, those used by scientific men—come from Paris and London. There is one maker of fine instruments in New York City. The Fahrenheit scale, which is common in the United States, receives but little favor at the hands of scientific men, who use the centigrade scale. The zero of the centigrade scale is freezing point; boiling point is 100° above freezing. We are used to the Fahrenheit scale, it is true; but if I tell you this morning that it is 20° below zero, you have to do a little sum in arithmetic before you find out that it is 52° below the freezing point. This calculation is not necessary in the centigrade or decimal system. In that 20° below zero means 20° below freezing. The English folk, in their method of talking about the temperature, are struggling toward the centigrade system. For example, they never say that it is 10° above zero, but 22° below freezing; not that the thermometer stands at zero, but that there are 32° of frost. Zero is the point at which salt water freezes. Mercury congeals at 39° Fahrenheit, and to register below that, spirit—alcohol or ether—must be used. But spirit is not as sensitive as mercury.

Obituary.

HERMAN NORDLINGER.

A cablegram announces the death of Herman Nordlinger, of the firm of Sussfield, Lorsch & Nordlinger, of this city. The deceased, although apparently a very strong man, has been ailing for some time, and previous to his going abroad passed some months in Florida. He failed to derive any benefit to his health in that climate, and was then advised by his physicians to take a trip to Europe. While on a visit to his native place, Hall, in Wurtemberg, Germany, he died suddenly in the house in which he was born. The supposition is that he died of heart disease, although no details of the sad event have been received by his firm. Mr. Nordlinger was a gentleman well known in the jewelry trade, and was much respected by all who had business dealings with him. He enjoyed an enviable reputation for business capacity and strict commercial rectitude. He was fifty-one years of age, and had been a member of the firm with which his name was identified for twenty-seven years. The deceased leaves a wife and six children, to whom the sympathy of a large circle of friends is extended. Mr. Sussfield, a member of the firm, was at Hall at the time of the death of his partner, and contributed everything possible to soothe and comfort the dying man in his last hours.

CHARLES W. BUECHNER.

Charles W. Buechner, a well-known traveler in the trade, died August 13, at the residence of his mother, in Newark, at the age of twenty-nine years, of typhoid fever. The deceased entered the employ of Field & Co. as a boy some eighteen years ago, and had been with this firm continuously to the time of his death. During the past ten years he has been the principal representative of the firm upon the road, in which capacity he made hosts of friends. He was of a genial, pleasant disposition, and highly respected by all who knew him.

J. F. HOPKINSON.

J. F. Hopkinson, a well-known manufacturer of gilt jewelry, died at Claremont, N. H., August 24th, in the 58th year of his age. The deceased had been an invalid for three or four years, and had gone to Claremont to pass the summer. Mr. Hopkinson had been in active business since 1855, and was well and favorably known in the trade.

Views of Correspondents.

This department of THE CIRCULAR is open for communications relating to the jewelry trade, but the editor does not hold himself responsible for the sentiments expressed by contributors. We invite correspondence, but require that it shall be free from all personalities, and the writer's integrity guaranteed by the disclosure of his true name to the editor. Anonymous communications will not be noticed.

A DIVERSIFIED STOCK PAYS.

To the Editor of the Jewelers' Circular:

I have been for several months past reading with much interest the complaints of jewelry dealers about outsiders, dry goods stores, etc., keeping jewelry. I, too, have had my share of this annoyance. I do not object so much to any one selling jewelry, etc., when they sell it at a profit, but when they sell it at cost, in order to sell their other goods, "then I kick." Some three years ago I took this idea, and find it works splendidly, besides being very profitable, etc.: I added stationery, perfumery, china ware, books, cutlery, pistols, albums, pictures, etc., and am much pleased. I would advise my fellow jewelers to try it, and my word for it they will be more than pleased, and will find the profit and sales very satisfactory. L. C. P.
Lancaster, S. C.

[The above is a sample of numerous letters we are receiving, all expressing the same degree of satisfaction with the results obtained from carrying a diversified stock, as recommended by THE CIRCULAR. Especially do dealers in small places, where the sales of jewelry are limited, find it to their advantage to carry attractive lines of other

goods. We cordially commend the plan of our wide-awake friend, "L. C. P."—ED.]

A PERIPATETIC JOBBER.

To the Editor of the Jewelers' Circular:

You will please find enclosed an advertising bill, circulated all through this section of the country by a man claiming to be in the jewelry trade in this place, which is not true, as he carries no stock, but has a number of catalogues of the leading jobbing houses of Chicago, which he brings out and shows to every inquirer, and gives them the cost prices of such goods as the party may select. You can readily see what damage a man of this kind can do to the legitimate trade. By glancing over the prices quoted on the enclosed bill, you will find they are the net cost prices to the trade. Is there not some way to stop such a man from obtaining goods from these houses. I make this complaint to you, for your CIRCULAR is a medium which every jeweler takes, and is looked upon as a sort of a protector of our rights. Houses that will furnish men of this class with goods do not deserve the support of the legitimate trade. L. R. D.

[The circular enclosed is signed Charles E. Wharton, and purports to give jobbers' prices for watches, cases, rings, clocks, etc. It would be interesting to know the names of the Chicago jobbers who are furnishing this man with goods. There is no doubt but the evils of this pernicious practice are being quite seriously felt, notwithstanding the boast of the Guild that it had broken up this style of huckstering by retail at jobbers' prices, through the medium of catalogues, furnished to whoever asks for them.—ED.]

PRESERVING "THE CIRCULAR."

To the Editor of the Jewelers' Circular:

I have been a constant subscriber to THE JEWELERS' CIRCULAR for a number of years, and feel to-day that I would not be without it for five times the amount of subscription asked for it, and think that no watchmaker in the country, whether he is doing business for himself or not, should be without it. To show my appreciation of it, I have this day *planted* a copy of it in the foundation of a two-story brick building which I am constructing especially for the jewelry and kindred trade. I am fitting it up in a very elaborate manner, and when completed it will be the neatest jewelry store in southwest Arkansas. Wishing you and THE CIRCULAR every success. W. S. W.

Hope, Ark.

[This correspondent's building will be proof against tornadoes, cyclones, earthquakes, and even the machinations of the Guild, for all time to come. We wish him a happy and prosperous career, which is assured to him if he follows closely the advice of THE CIRCULAR.—ED.]

A TOOL NOT PARTICULARLY USEFUL.

To the Editor of the Jewelers' Circular:

Some time since I saw an advertisement in THE CIRCULAR signed by "F. P. Bishop, President Michigan Retail Jewelers' Association," announcing that on receipt of \$1 he would send to any one by mail a tool "such as we used in the Elgin Watch Factory. It makes staff and pivot work easy," etc. I sent for the "tool," and here is a description of it: The handle is of maple, straight and varnished, and very much resembles a section of a common broom handle. The wires are made from a medium-sized knitting pin, with the temper drawn to admit of filing the notches in the outer end, and they are driven into the handle, which, I forgot to say, had a brass ferrule, made to keep its place by four prick punch marks. On the whole, I do not consider the tool either ornamental or useful. It might be of some use on a common 3-armed balance, but I should fear to try it on cut chronometer balance. I should say the "tool" was fearfully and wonderfully made, and I think could be got up for about ten cents. While I do not attach any blame to THE CIRCULAR, I think you ought to know what kind of goods your advertisers deal in. T. J. T.

Burrillville, R. I.

A RETAILER'S SUGGESTIONS.

To the Editor of the Jewelers' Circular:

I have read your editorial in June number, and was so struck with the good sense and "solid facts" in it that I want to write a word in regard to it. Now; while it may be unpalatable, it is just as it is; you have it down fine. There is this much about it, the retailer ought to know more about jewelry, etc., than outsiders; ought to have a better way to buy—in short, it should be their own business.

There is no use in having meetings, and holding conventions and passing resolutions. What we want is a convention with a business end to it that will tell. Perhaps you will say talk is cheap, but will you suggest something. With a lively sense of my inferiority, and with due deference, I will make a suggestion. In the first place, if a man comes in the factory with a few hundred or thousand dollars in cash to buy goods, the manufacturer is going to sell him goods on his best terms, if he has a customer who is a judge, and shrewd. They won't refuse the cash—not much. Now, suppose the retailers in each county have a meeting and elect one of their number to do the buying for them directly from the manufacturers, for cash; paying his expenses, and for his time, of course. Each one to make out a list of what he wants and hand over the shekels, getting as near the cost as he can, and adjusting after. We must choose a man we have confidence in—a man of integrity, and all work together secretly. We could buy 50 per cent. cheaper than we do now, and give the outsiders a slap in the face that would make them stare for a while, until they found out our little game. This is my idea, in a rough way, and is *not* intended for publication. S. D. J.

To the Editor of the Jewelers' Circular:

Some time since I sold a set of 14 karat jewelry to a customer, who, after wearing one or two weeks, brought it back all tarnished and black. She stated that the ear rings discolored the ear, and that a plain gold ring that I sold her at the same time also turned her finger a greenish hue. My competitor in town told her that the goods were not gold, and advised her to throw the goods on my hands. Now, I have had the pin assayed, and found it within a trifle of 14 karats, and this seemed to satisfy my customer, but it did not solve the mystery. Will you kindly shed some light on the matter. K. O. U.
Iowa.

[The wearer has either been in habit of using hair-dye, or has at some time or other taken large quantities of sulphur or calomel. On referring to your back numbers of THE CIRCULAR you will find this subject treated at length.—ED.]

TRAVELING AUCTIONEERS.

To the Editor of the Jewelers' Circular:

I wish that you would again go for those peddlers and traveling auction men who go about from town to town destroying the trade of the local dealer, who, between the catalogue-issuing firms of Chicago and these pirates, have a hard scratch to make a living. A few days since a traveling auction firm came into our town and flooded the place with hand-bills, and proposed to swindle the entire community; but I got to windward of him by announcing that I would sell at cost during the week these skins were in town. The result was that I got rid of a lot of old stock that hung fire, and got the cost for them, so that I am enabled to get a nice little stock of new goods with which to open the fall trade. C. S. A.

China Painting.

CHINA painting gives great scope to an artistic taste. It is a very fascinating domestic industry. Productions of this kind, when artistically executed, are exceedingly ornamental, if not reduplicated to excess. Massing in home art exhibits destroys all striking effects. In order to appreciate such works, breadth, space in representation is absolutely necessary. Bric-à-brac crowded has no sentiment; true color only shows to splendid advantage in an appropriate expanse. The colors and shadows of the gorgeously setting sun are gloriously enhanced by the grandeur and breadth of the firmament. China painting cannot be executed with success as an art unless the hand is guided by an æsthetic judgment. In the choice of familiar designs, if accurately copied, there is no danger of making any mistake, since there is generally some merit in what pleases the majority. The great difficulty in china painting, as practised at home, is that an original sense of the beautiful appears to be a stranger in nine cases out of ten. Doubtless this glaring defect can be obviated by paying more attention to the details of this industry. It is indeed surprising what valuable knowledge can be acquired by a wise investigation of the fundamental principles governing true art.

Beginners in china painting cannot, at first, exercise the free hand use of the brush in designing; however, patience and close study will soon accomplish this. At first the inexperienced will be safer to

make copies, introducing such changes and additions as one's fancy may suggest. Select a tile or plate, a saucer or cup—in fact almost any small article is the best for the beginner—rub a little turpentine over the article, then draw the design with a hard pencil. Some use transfer paper in tracing the desired pattern. After it is drawn lay the paper on the article to be painted, fastening the corners down with a touch of mucilage. Go over the design with a pencil, and remove the paper and lay in the colors, following the copy as accurately as possible. Mistakes are easily wiped out by using a bit of rag dampened with turpentine. It is always best to use brushes of various sizes. There are, however, lovely designs that can be executed with one brush. Delicate strokes, of course, require very small and sharply pointed brushes. Be very careful in packing the articles to be fired that the painting does not get injured. The slightest rub against the work will produce a glaring defect. Pack in very thin paper. The hand-rest is an indispensable article. Without its aid there is not one in a hundred who can command a steady stroke with the brush for any length of time. In selecting colors for china painting a little instruction is necessary, since there are tints that disappear when exposed to the heat of the baking (firing) process. Some of the yellows cannot be mixed with any other color, as they will, in the firing, completely obliterate them, no matter how clear the shade may have been at first. The rules for the use of yellow paints are principally based on the proportion of iron employed in their manufacture. Blue and carmine form a pretty purple that is not changed by the furnace heat. A beautiful flesh tint is secured by mixing ivory-yellow and blush-red. A very rich red is obtained by painting over orange-yellow (after it has been fired) with capucine-red. The iron colors are grays, black, ochres-browns and brown-yellows, red-browns, flesh-reds, violets, and the deep reds. The expense of an outfit in china painting is quite unnecessary; for those just beginning to learn the art only a few tools need be purchased. A couple of camel's hair brushes, two blenders, a palette knife, a bit of India ink, a tracing brush, rest-stick and palette; the cost of all will not exceed \$1.50—about two dozen tubes of paint, from 18 to 30 cents each. A small bottle of turpentine will last a long time.

There are small kilns especially manufactured for home use, costing from \$2.50 up to \$25. However, these kilns are not always reliable, especially the small ones. It is safer to send the pieces painted to a large china store where firing is done. The expense is but a trifle, from five, ten and fifteen cents, according to the size of the article. Refiring is sometimes necessary, since there may be defects exposed by this process, and all such can be again tacked up with the brush. Many artists advocate two or three firings as decidedly necessary.

Stained glass windows are rather expensive to the majority. This artistic home adornment has, however, been brought by science within the possession of those who always carry a limited purse, and yet love the beautiful most ardently. At a very small expense a lovely substitute for stained glass may be had. "The Opalin" window decoration is very desirable. There are a series of designs in this style of decoration that are remarkably diversified, all of which may be admirably utilized by a person possessing taste and judgment. This fashion of window decoration is easily applied; wet the glass and then lay on the pieces, which come in various sizes, and when affixed they cannot be rubbed off or defaced by cleaning. A window commanding an unsightly view, if adorned with opalin, gives a picturesque effect, and yet the light is not obscured, as it would be if heavy curtains were used. A very pretty and also cheap pattern of this goods represents ground glass. Sometimes a border of the tinted opalin is used, which gives a handsome finish to the ground glass centers. A cottage home with the windows adorned in this style adds greatly to the beauty of the house. Another simple yet most satisfactory style of window decoration can be had for a few pennies; an ounce of epsom salts mixed with a pint of brewed beer will make a sort of paste; trace this in irregular forms on the panes of glass, and the result will be very pleasing, giving a pretty and interesting decoration that will last several months if not molested.

Workshop Notes.

ECONOMICAL GILDING.—To gild works of art in bronze, gas fittings, etc., the following mixture is recommended: $2\frac{1}{2}$ pounds of cyanide of potassium, 5 ounces of carbonate of potassium, and 2 ounces of cyanuret of potassium, the whole dissolved in 5 pints of water containing, in solution, $\frac{1}{2}$ ounce of chloride of gold. The mixture is to be used at boiling heat, and after it has been applied, the gilt surface varnished over.

CLEANING IVORY ORNAMENTS.—Ivory ornaments are quickly cleaned by brushing them with a new, not very sharp, tooth brush, to which a little soap has been given, then rinse the ornament in lukewarm water; next dry it and brush a little, and continue brushing until the luster reappears, which can be increased by pouring a little alcohol upon the brush and applying it to the object. Should this have become a little yellow, dry it in gentle heat, and it will appear as if new.

BLEACHING YELLOW IVORY.—Ivory that has become yellow, may easily be bleached in the following manner: The article is placed under a glass bell, together with a small quantity of chloride of lime and muriatic acid, whereby chlorine is developed, and exposed to sunlight. Be very careful not to breathe the vapors, as they are very poisonous. The bleaching power of the chlorine destroys the yellow pigment upon the surface, and the article will be restored to its original luster.

JEWELERS' SOLDER.—To make platinum firmly adhere to gold by soldering, it is necessary that a small quantity of fine, or 18-karat gold shall be sweated into the surface of the platinum at nearly white heat, so that the gold soaks into the face of the platinum; ordinary solder will then adhere firmly to the face obtained in this manner. Hard solder acts by partially fusing and combining with the surfaces to be joined, and platinum alone will not fuse or combine with any solder at a temperature anything like the ordinary fusing point of ordinary gold solder.

A USEFUL ALLOY.—It is said that the following alloy will attach itself firmly to glass, porcelain or metal: 20 to 30 parts of finely pulverized copper, prepared by precipitation or reduction with a battery, are made into a paste with oil of vitriol. To this 70 parts of mercury are added and well triturated. The acid is then washed out with boiling water, and the compound allowed to cool. In 10 or 12 hours it becomes sufficiently hard to receive a brilliant polish, and to scratch the surface of tin or gold. When heated it is plastic, but does not contract on cooling.

PUTTING A DUPLEX INTO BEAT.—A duplex may be gotten into beat by noticing when the balance is at rest that the notch in the ruby is about half way between the line of center and the locking tooth; I say about half way between, because the duplex, like all other escapements, varies considerably in construction, but this rub is near enough for most kinds, as the operator may soon tell by listening closely to the ticking of the watch, and altering the balance spring a little either way. When the balance is started from its rest, it will have to move about ten degrees before the locking tooth is brought into action.

OIL FOR SHARPENING TOOLS.—A French paper gives the following substitute for oil for sharpening tools: Instead of oil, which thickens and makes the stone dirty, a mixture of glycerine and alcohol is used. The proportions of the mixture vary according to the instrument operated on. An article with a large surface, a razor, for instance, sharpens best with a limpid liquid, as 3 parts of glycerine to 1 part of alcohol. For a graving tool, the cutting surface of which is very small, as is also the pressure exercised on the stone in sharpening, it is necessary to employ glycerine almost pure, with but two or three drops of alcohol.

BLEACHING IVORY FOR CUTLERY PURPOSES.—Peroxide of hydrogen is used in Sheffield to bleach the inferior ivory for knife handles. The mode of procedure is as follows: Place, say, 2 quarts of the liquid in a stone pot, adding 4 ounces liquid ammonia; strength, 88° , immerse the handles, and put over a common shop stove for 24 to 36 hours; the handles are then taken out and gradually dried in the air, not too quickly, or they would split. The deep color of the ivory is removed, and a beautiful pearly white ivory results when polished. The ivory is previously treated with a solution of common soda, to get rid of greasy matter and open the pores.

SILVERING IRON.—Mr. C. Saton, of Vienna, first covers the iron with mercury, and silvers by the galvanic process, by heating to 300° ; the mercury evaporates, and the silver layer is fixed. Ironware is first heated with dilute hydrochloric acid, and then dipped in a solution of nitrate of mercury, being at the same time in communication with the zinc pole of an electric battery, a piece of gas carbon or platinum being used as anode for the other pole. The metal is soon covered with a layer of quicksilver, is then taken out and well washed and silvered in a silver solution. To save silver, the ware can first be covered with a layer of tin; 1 part of cream of tartar is dissolved in 8 parts of boiling water, and one or more tin anodes are joined with the carbon pole of a Bunsen element. The zinc pole communicates with a well cleaned piece of copper, and the battery is made to act till enough tin has deposited on the copper, when this is taken out and the ironware put in its place. The ware thus covered with tin chemically pure, is silvered, and is much cheaper than any other silvered metals.

ANOTHER IMITATION IVORY.—As is well known, one of the disadvantages of celluloid is the fact that it burns very readily when a flame is applied, but a new compound said to be fire-proof and suitable as a substitute for ivory is thus made: A solution is prepared of 200 parts casein in 50 parts of ammonia and 400 of water, or 150 parts of albumen in 400 of water. To the solution the following are added: Quicklime, 240 parts; acetate of alumina, 150; alum, 50; sulphate of lime, 1,200; oil, 100. The oil is to be mixed in the last. When dark objects are to be made, from 75 to 100 parts of tannin are substituted for the acetate of alumina. When the mixture has been well kneaded together, and made into a smooth paste, it is passed through rollers to form plates of the desired shape. They are dried and pressed into metallic moulds previously heated, or they may be reduced to a very fine powder, which is introduced into heated moulds and submitted to strong pressure. The objects are afterward dipped into the following bath: Water, 400 parts; white glue, 1 part; phosphoric acid, 10 parts; finally they are dried, polished and varnished with shellac.

FROST-LIKE APPEARANCE ON SILVER.—The dead fretted appearance on silver is produced in the following manner: The article has to be carefully annealed either in a charcoal fire or with a blow-pipe before a gas flame, which will oxidize the alloy on the surface, and also destroy all dirt and greasy substances adhering to it, and then boiled in a copper pan containing a solution of dilute sulphuric acid—of 1 part of acid to about 30 parts of water. The article is then placed in a vessel of clean water, and scratch-brushed or scoured with fine sand, after which the annealing and boiling-out is repeated, which will in almost all cases be sufficient to produce the desired result. If a very delicate dead surface, such as watch dials, etc., is required, the article is, before the second annealing, covered with a pasty solution of potash and water, and immediately after the annealing plunged in clean water, and then boiled out in either sulphuric acid solution, or a solution of 1 part cream of tartar and 2 parts common salt to about 30 parts of water. If the article is of a low quality of silver, it is well to add some silver solution, such as is used for silvering, to the second boiling-out solution. If the article is of very inferior silver, the finishing will have to be given by immersing it in contact with a strip of zinc in a silver solution.

Trade Gossip.

The latest agony is a perfumery finger ring.

Frear & Woodworth is the name of a new firm just established in the jewelry business at Binghamton, N. Y.

Henry J. King, an old and well known traveler, has entered into a business engagement with the Meriden Britannia Co.

The failure of William B. Fowle, Treasurer of the Auburndale Watch Co., is announced. His liabilities are said to be small.

Charles Glatz has secured the agency of Thiery's American-made nickel cases, to which the attention of the jobbing trade is directed.

F. Kroeber presents many attractive novelties in French clocks of the newest designs and patterns, and an unusually full line of staple goods.

The Ohio Watch Tool Co., formerly the Olin Chuck Co., are now comfortably settled in their new quarters at Piqua, Ohio, and ready for business.

Lissauer & Sondheim, through their seven travelers now on the road, present a large and attractive line of goods that cannot fail to suit purchasers.

A fire in the workshop of E. C. Farnsworth, jeweler, on the fourth floor of No. 81 Nassau street, caused by an overheated furnace, caused a loss of \$1,000.

Henry Fera recently returned from Europe in the *Werra*. During his stay abroad he had the good fortune to secure several parcels of extraordinary fine gems.

Aug. Talpfert, for many years with Messrs. Duhme & Co., of Cincinnati, has entered into a business engagement with Messrs. J. S. Voss & Son of that city.

James Gilowsky, for many years with Theo. Schelle, of Milwaukee, succeeds to the business of the latter gentleman. Mr. Schelle has returned to his native land.

B. H. Steiff, of Nashville, Tenn., was recently in town making his fall purchases. He carries a fine line of goods, and is a gentleman of excellent taste and a critical buyer.

The large clock located in the basement of the Waltham factory, from which the tickers are struck, is said to keep better time even than the famous Cambridge clock, and its variation is very slight indeed.

In the early part of August a fire occurred in the warerooms of Joseph Fahys & Co., in Maiden lane; it was one of those unaccountable fires whose origin is attributable to the cat. The loss was trifling.

A young lady of San Francisco is solving the problem of the higher education by traveling about the streets with a neat little kit mending jewelry and fancy articles. That is business, and very much better than talk.

A Montreal jewelry firm, who were caught with smuggled goods in their possession, have effected a compromise with the custom authorities by the payment of \$12,000, the amount of duty and fine imposed by the customs.

Vacheron & Constantin, of Geneva, have recently issued a circular in which they particularize recent additions made to their facilities for making watches, and announce that they continue to make movements that will fit American cases.

The Howard Watch and Clock Co. are building for the new Produce Exchange a tower clock with four 12-foot dials, and electrical dials inside. It will also have electric contact for striking gongs in the board-room for regulating deliveries.

The Lancaster Watch Company, of Pennsylvania, suspended temporarily last month on account of the embarrassment of Mr. Bittner, who was largely identified with the company. Matters have since been arranged and the company has resumed operations.

C. L. Dennison, whose name is associated with the early history of watchmaking in America, is on a visit to his friends in the Eastern States, he having been absent in Europe for some years. He was one of the pioneers in making watches by machinery.

The New York Jewelers' Club held its regular monthly meeting Tuesday, August 14. Without transacting any business the club adjourned, out of respect to the memory of one of its members, Charles W. Buechner, and attended his funeral in a body.

The Retail Jewelers' Association of Ohio announce that they will meet at the American House, Columbus, Ohio, September 4th, to enact rules and regulations for the protection of the retail trade. Every retail jeweler in the State is invited to be present at the meeting.

Dakota can boast of a jeweler who is even smaller than the late Tom Thumb. His name is Commodore Dwigans, and he lives in Miller, Dakota. Dwigans is twenty-seven years old, weighs about thirty-five pounds, is three feet, four inches in height, and is a jeweler by trade.

Rouison L. Wood, a jeweler, of No. 14 John Street, caused the arrest of Charles Cummings, who he said lived at Lancaster, Pa., on June 30, for attempting to steal some gold rings, valued at \$57. In the General Sessions Court Cummings was sentenced to six months in the Penitentiary.

Keller & Untermeyer, of this city, present to the trade through THE CIRCULAR, a very attractive illuminated page, illustrating a few designs of cases made by them. These exhibit but a limited number of their designs in raised gold ornamentation which are highly popular in the trade.

The Marvin Safe Co. has made for Steven Thomas, Jr., & Bro., of Charleston, S. C., a fire and burglar-proof safe that is calculated to drive the ordinary "cracksman" frantic. It is not only elegant in appearance, but embraces all the modern safety improvements, and is as nearly perfect as skill and intelligence can make it.

The Derby Silver Company has leased the premises No. 3 Union Square, formerly occupied by Le Boutillier & Co., the latter firm having removed to 31 & 33 West Twenty-Third street. The Derby Company is now fitting up the store in an attractive and substantial manner, and expect to occupy it by the middle of the month.

Blancard & Oberlander, of this city, have devised a method and machinery for making hollow balls or shot for decorating Etruscan and diamond jewelry. The balls can be made either uniform in size or graduated, have no seam, and are perfectly round. This is regarded as an important improvement in the jewelry trade.

Frank E. Knight, the able and courteous manager of the Meriden Silver Plate Co., has been seized with the insane desire to take another man's child to keep. He was married August 8 to Miss Etta Lambert, of Mount Vernon, N. Y., and the happy pair are now arranging for the furniture to commence housekeeping with.

Julius Woodiska has introduced a new method of manufacturing seal rings. It is a patented device, by means of which a small spring concealed inside presses a small plate upon the finger, thus holding the ring fast. To those who possess large knuckles this device is of importance, as the ring is held in place after passing the knuckles.

L. A. Parsons, of Messrs. Wheeler, Parsons & Hayes, has been enjoying a brief vacation at Saratoga and Lake George. Mr. Parsons is one of the best known men in the trade, and his numerous friends who called during his absence have missed his genial countenance and friendly greetings with which he is accustomed to receive them.

Another old friend meets our eye as we glance through the rural exchanges. It appears every year at this season, and its familiar face is unchanged, though it has been the cynosure of millions of eyes for many generations. Bear with us while we introduce it again. Here it is: Another large diamond of extraordinary purity has been found in Georgia.

N. H. White, general jobber in Waltham watches and cases, is sending out very attractive circulars, artistically illuminated by the lithographic process. He devotes himself especially to handling one kind of goods, and keeps that complete in every respect. Mr. White is one of the enterprising men in the trade, and his success is as great as it is deserving.

Messrs. Greenshields & Co., acting for Thomas Allan, jeweler, of St. James street, Montreal, have entered an action against Mr. Cochenthaler for \$5,000 damages for making and selling a species of jewelry which the plaintiff has registered at Ottawa. The distinctive feature of the jewelry in question is that it consists of curved snowshoes with the tuque and thongs.

Some burglars recently obtained entrance to the jewelry store of Henry Birks & Co., of Montreal, by breaking into adjoining premises. They attacked the safe in the store, but becoming alarmed failed to complete their work, and no damage resulted from their visit. They left evidence behind them that they were professional "cracksmen," and supplied with the most approved burglars' tools.

For the King of Siam has been made in London a remarkable ring. It is to be used by his Majesty only once a year, and then as head of the Buddhists in Eastern India. The central stone is $1\frac{1}{4}$ inches in diameter, and is encircled by a ruby, an emerald, a sapphire, and five other stones. The mounting is described as light and elegant, though strong. Emblems of the Buddhist faith are displayed.

The employees of the Waltham Company have formed a brass band, which is said to be the best in New England. They play high-class music, and are under the leadership of a thoroughly competent musician. This band is frequently invited to furnish the music on festival occasions, and have received many compliments from distinguished persons for their rendering of classical music.

Maiden Lane is probably one of the most polyglot streets in the world. A person passing through it will hear the English, French, German, Spanish, Italian, Hebrew and Greek languages spoken, and occasionally rendered with a sinewy Saxon accent that will make the hair stand on end. In addition to all these, an occasional Jerseyman comes over and pervades the street with accents peculiarly his own.

H. H. Heinrich, a skillful workman of this city, has received from the Yale Observatory the highest mention of praise for his celebrated self-adjusting Marine chronometer balance. The chronometer was subjected to the severest tests in high and low temperature, and was accorded the highest position in the report. This is the third horological institute that has conferred on Mr. Heinrich the highest distinction of merit.

A Peruvian living in Milan has made a clock entirely out of bread. Too poor to purchase metal, and with only a certain allowance of bread daily, he deprived himself regularly of the soft portions of the loaf, satisfying his hunger with the crusts. He used a certain salt to solidify his material, which then became hard and perfectly insoluble in water. The clock keeps good time, and the case, made of hardened bread, is handsome.

J. S. Clyne, a small dealer doing business in Galveston, Texas, is reported to have gone where the woodbine twineth, and a number of his creditors are desirous of ascertaining the precise location of this particular woodbine. He left suddenly with some jewelry in a grip-sack, reporting to a clerk his whereabouts for a time, but finally all trace of him was lost. Several St. Louis and Chicago jobbers are victimized to the extent of several thousand dollars.

There is every indication that there is going to be a scarcity of silver cases in the market. The taste for the better grades of these goods is as critical and exacting as it is capricious. Dealers demand a better quality of cases, and many of those made a year or so ago are now moved but slowly, as they are regarded as passé. The demand is for a higher grade of workmanship and finish, and we do not see how it is to be gratified at the present prices of silver cases.

On the 30th of last June, Joseph H. Hart, of No. 164 West 23d street, who claims to be a theatrical agent, obtained five diamond rings and one diamond pin, of the value of \$500, from Morris Ginsberg, jeweler, at 66 Nassau street, on the pretence that he had customers for them, and that he would be able to dispose of them on commission. Subsequently it was discovered that he had pawned them for \$300. He was charged with grand larceny before Justice Herrmann at the toms and was held for examination.

A red-headed, rum-soaked swindler may be seen any day in the Bowery playing a confidence game that some time will get him into trouble. For five or ten cents he buys a brass ring from a Bowery peddler's supply shop. The ring is thick, and on the inside is stamped 18—K. Sometimes a name is also stamped within. The fellow's method of operating is to tap a stranger on the shoulder and say: "Excuse me a moment. I just found this ring, and it's the pure article. I'm mighty hard up, and am willing to sell it for a dollar or two." He always seems to find fresh victims daily.

W. A. Skidmore, who has just returned from Sierra County, informs us that a remarkably rich quartz boulder, weighing 160 pounds, was hydraulicked out of the bank of the Nevada Hydraulic Co., at Gibsons ville, last week. The boulder was smoothly washed, having the appearance of being ground in a pot-hole. Its value is about \$2,500, and nearly all of it is suitable for quartz jewelry. The estimate of the \$2,500 is made on the basis of a fineness of gold of 900, at \$18 per ounce, but this class of gold commands \$25 per ounce when used for cutting by lapidaries. The value is computed by the specific gravity of the rock.

Charles Truman, alias Curtis, and Edward Magee, alias Mason, two dextrous jewelry store sleight of hand thieves, who had just completed fifteen months' imprisonment for attempting to steal gold chains from Messrs. McCarty & Hurlburt of Philadelphia, were rearrested upon their release from the Eastern penitentiary, on a charge of having in January, 1882, stolen \$1,200 worth of jewelry from the store of Theodore B. Starr, of this city. The men went into the store, and while examining jewelry which they pretended to desire to purchase, succeeded in stealing several diamond rings.

A Brooklyn watchmaker, whose name might be Procrastination, finding business dull, thought he would make up for lost time by appropriating his customers' watches and dispose of them at his *uncle's*. One of his victims, objecting to his method of conducting business, invoked the assistance of the local police, who succeeded in winding up the wayward career of this speculating watchmaker. It is alleged that the party of the first part succeeded in pawning some seventy or eighty watches that had been left by his customers for repairs. His address for the next twelve months will be Crow Hill.

Messrs. L. & M. Kahn have secured one of the largest diamonds ever brought to this country. It is an African stone, weighing 126 karats in the rough. It has undergone the process of cleaving, and is now ready for the hands of the cutter and polisher. The quality and value of the stone cannot be determined until the work upon it is completed, but there is every indication that it will prove to be an exceedingly valuable stone. It has already attracted much attention in the trade and with experts. The Morse Diamond Cutting Company of Boston will, in all probability, take charge of the cutting of this valuable stone.

It would be interesting to know what becomes of all the money paid into the so-called National Guild. The officers claim that the organization is a success; to be a success, it must have a large membership, and members are required to pay annual dues. What becomes of the money? We have never seen any report of receipts and disbursements, and the matter seems worth inquiring into. The secretary is allowed a salary, but we are not informed what compensation the president receives. Is it possible that all the funds are consumed in paying salaries to officers and their traveling expenses? An official statement, showing the facts, would be in order.

Messrs. C. L. Tiffany & Co. have in their employ several young salesmen who rank as first class athletes, and who pride themselves on their skill with the oar or fleetness of foot on the cinder path. For some time past there has been a desire on the part of Messrs. J. C. Mettune, N. J. Duffy, H. H. Freadwell and W. J. Hutchinson to settle the question of who is the best oarsman. Recently a match was made between N. J. Duffy and W. J. Hutchinson for a silver cup, valued at \$20, and the race came off a few evenings ago, Hutchinson receiving a handicap of fifteen seconds from Duffy. The race was a mile, and both men rowed in racing gigs. Hutchinson crossed the line a winner.

A dealer from a small town in Missouri was in the city recently to buy a few goods, and represented that he was on the list of one of the watch companies as a jobber. He was at once besieged by the "box men," who were all anxious to sell to him, and the poor fellow was beside himself to find how good his credit was. He concluded, however, that he might as well have the game as the name, and so he bought a trunk and started home loaded down with goods, and prepared to begin the fall campaign as a full-fledged jobber. Since his departure, inquiries have failed to discover his name in any jobbers' list kept by any watch company. This is another illustration of the ease with which credit is obtained in the jewelry trade.

Suits for more than \$10,000 recently begun in Chicago against Mike McDonald, the keeper of a gambling house, recall the unfortunate ventures of a New York salesman named Pollard. The suits are to recover the value of diamonds and other precious stones which Pollard had exchanged for chips in McDonald's place in 1879, afterward losing the chips at the game. Pollard was the agent of various New York diamond firms, who had entrusted him with their goods to sell. Pollard was never prosecuted. He had previously borne a good reputation. His story was that he fell in with some friends in Chicago, drank with them, visited the gambling place, and played until he had lost all his own money, and that then, under the impulse of excitement, he risked the property that had been entrusted to him, and lost it. The losers say that they are not pursuing the suits against McDonald with any vindictive spirit, or to punish anybody, but only to get back their property.

A novel method of effecting the removal of a ring which has become constricted around a swollen finger, or in any other similar situation, consists simply in enveloping the afflicted member, after the manner of a circular bandage, in a length of flat India rubber braid, such as ladies make use of to keep their hats on the top of their heads. This should be accurately applied—beginning, *not* close to the ring, but at the tip of the finger, and leaving no intervals between the successive turns, so as to exert its elastic force gradually and gently upon the tissues underneath. When the binding is completed the hand should be held aloft in a vertical position, and in a few minutes the swelling will be perceptibly diminished. The braid is then taken off and immediately reapplied in the same manner, when, after another five minutes, the finger, if again rapidly uncovered, will be small enough for the ring to be removed with ease.

It would be naturally supposed that the supply of "ancient Dutch clocks" must be exhausted in time, but there is a strong suspicion that the ingenuity of unprincipled dealers will always keep the supply equal to the demand. A correspondent of the *Philadelphia Press*, who has been traveling leisurely through the rural counties of Pennsylvania, explains how this is done. In one of the small villages on his route, he came across an old cabinet maker who was constantly engaged in making cases for Dutch clocks. He seemed to be innocent of any intent to cheat, for he showed the correspondent his shop, and explained that the present taste for clocks of the old pattern kept him busy. He said that he made the rough cases to order for a dealer, and that the works were made in Connecticut. He didn't know who did the finishing. "The dials," adds the correspondent, "are painted in the old fashioned manner, and the clock is turned out so as to resemble a timepiece 100 or more years old. It is then stood away in some dark corner of a mouldy log house, until finally it is 'accidentally discovered' by the owner and dealer, who sends it on to New York or Philadelphia to be sold as an aged relic."

The tendency of the times (says the *Chicago Stationer*) is to concentrate every class and description of business under one roof. The popular store, and the money-making store, is the one that runs dry goods, notions, hardware, carpets, boots and shoes, books and stationery, and a little bit of everything under the sun. It looks as if almost every kind of business was going to be swallowed up by these mammoth bazaars, where an immense quantity of goods are sold at a very close profit. In the larger cities, New York, Chicago, Philadelphia, there is to-day a hard struggle for existence among many business men engaged in what is known as a class business. Books alone no longer pay; stationery alone no longer pays; paper alone no longer pays—unless an "almighty" lot of it is sold; so we might go through other classes of business and point out the fact that, as a separate and special business, they can no longer compete with a concern which gathers dry goods and groceries, hardware and notions, drugs and chemicals, all under one roof. The fact that stares the business man in the face to-day is, that if this thing keeps on he has got to go out of his business, or fall into line and lay in a stock of everything.

Caveat emptor is a maxim much needed by purchasers of Japanese art productions. We constantly see pieces of so-called Satsuma ware offered for sale, but if a writer of a history of Japanese ceramics in the *Chrysanthemum* magazine of Yokohama, who appears to understand his subject, is to be believed, there can be little or no real Satsuma-yaki, as it is called, in Europe. He "unhesitatingly asserts" that the ware sold under this name in Europe and America differs "in many and most essential respects from the beautiful faience so highly prized by the Japanese connoisseurs." The old Satsuma is described as hardly at first sight to be distinguished from ivory, with an exquisitely smooth surface and an almost imperceptible crackle. The ware which is made for the foreign market is a crude, chalky pate, covered with coarsely fissured glaze, in which frequently an excess of felspar has produced discolored deposits. Much ingenuity and patience, indeed, are lavished on the decoration of these indifferent manufactures, but the pieces thus produced find absolutely no sale in Japan itself. "Not alone does their garish ornamentation exceed the most extreme limits prescribed by the æsthetic chastity of the tea clubs, but their imperfect workmanship lends an unpleasant air of sham to the pains taken in pranking them out."—*Pall Mall Gazette*.

The coronation of the Czar brought to light some curious and ancient works of art which are only seen at long intervals. The nucleus of the Russian regalia is Byzantine, and of great antiquity. It was sent by the Greek Emperor Constantine Monomachos to Kief in 1114 by the hands of the Archbishop of Ephesus and the Bishops of Mitylene and Antioch. Of this original treasure, first used at the coronation of Vladimir Vsevolodovitch, the grandson of St. Vladimir, several portions are said to exist still uninjured; in particular, a jeweled cross, a bowl of gold inlaid with mother-of-pearl, which is said to have belonged to the Roman Emperor Augustus, and the Imperial Coronet of the autocrats of Russia. This last ornament was used upon every occasion down to the coronation of Fedor Alexeievitch, since whose reign it has been usual to place on the Czar's head one of the two crowns made for the occasion of the simultaneous enthronement of John and Peter Alexeievitch. This modern regalia of Russia, in the midst of which the beauty of these ancient and barbaric objects will be lost, is said to possess no great artistic value.

A few years since retail jewelry houses confined themselves strictly to what might be termed legitimate lines. Of late many dealers have found it to their advantage to add lines of goods suitable for wedding, birthday and holiday gifts, which are usually classed as bric-à-brac, such as choice bisque figures, groups and busts, Parian and Italian marble, plaques, French china and faience vases, Hungarian faience, Royal Worcester, Minton and Dresden wares, fine Bohemian colored glass pieces, Barbotine vases, Italian and lava figures and animals, Carlsbad flower ware, etc. Some of our New York houses are making special efforts to secure this, to them, new line of trade, and prominent among them is the large importing house of Bawo & Dotter, who have an extensive establishment in Barclay street. A member of the firm spends the quarter part of each year in Europe and secures many of the best productions of the best workshops in that center of art. The addition of such lines as indicated is an important move in the right direction, and will do much to counteract the introduction of lines legitimate to the trade by outside houses.

The *Sussex* (N. J.) *Herald* tells an interesting story of an old clock, which was made by Anthony Ward, in Germany, who is recorded as having died old and blind, about the year 1650. The clock is now owned by Mr. S. H. Stivers, of Branchville, Sussex County, N. J. It was brought to America by John Kanuff, who landed on Manhattan Island in 1623. Kanuff was the great grandfather of Mrs. William Beemer, one of the first settlers of Frankford Township, Sussex County. William Beemer died thirty years ago, and the clock was sold at that time among other effects to settle up the estate. When the Sussex Railroad began to run trains to Branchville in 1868, Superintendent Timothy Case thought it would compliment the old clock to have it mark time for the road at that station. He had it cleaned up and placed in the depot, but two years ago the company replaced it with a more modern timepiece. The old clock is one of the old-fashioned high ones, with plain walnut case. The face is of solid brass, with figures and ornaments carved. In addition to marking the seconds, minutes and hours, it also tells the day of the month.

According to general newspaper report, Mr. Porter Rhodes, the fortunate owner of the priceless diamond that bears his name, is at present in Paris awaiting the result of a competition between two millionaires desirous of possessing the jewel. The stone was found in his mine at Kimberley, South Africa, in the beginning of 1880, and made a great sensation among the diggers when the discovery was made known, about four months later. Mr. Porter Rhodes was obliged to satisfy their curiosity by exhibiting the diamond. Accordingly he placed it in a friend's office, charged a sovereign for admission, and in this way received £100 within the first two hours. Altogether he made by the exhibition £500, which he gave to the local hospital. On his arrival in England he was honored with an invitation to Osborne, in order that Her Majesty might inspect the stone. He was afterward taken to Osborne Cottage and had an interview with the Empress Eugénie. Mr. Porter Rhodes considers that his diamond as far surpasses the Kohinoor in purity as it does in weight, the Indian stone weighing 106½ karats, the Cape diamond about 150 karats. He said to his interviewer: "I shall have, at least, fulfilled one mission; I shall have convinced the world that the Cape diamonds are as radiantly pure and blue white as the Dresden drop and the Braganza. I shall thus upset one popular delusion."



VOLUME XIV.

NEW YORK, OCTOBER, 1883.

No. 9.

THE JEWELERS' CIRCULAR AND HOROLOGICAL REVIEW

*The recognized organ of the Trade, and the official representative of the
Jewelers' League.*

A Monthly Journal devoted to the interests of Watchmakers, Jewelers, Silversmiths, Electro-plate Manufacturers, and those engaged in the kindred branches of art industry.

SUBSCRIPTION:

To All Parts of the United States and Canada,
\$2.00 Per Annum; Postage paid.

To Great Britain, France, Switzerland, Germany, the West Indies, Mexico, the Republics of South America, and Australia, \$3.00 per annum. Postage paid.

All communications should be addressed to D. H. HOPKINSON, 42 Nassau Street, New York. Advertising rates made known on application.

Necessity for a National Bankruptcy Law.

WE HAVE taken frequent occasion to assert that a national law regulating bankruptcy proceedings in all the States, is a necessity of the extended commercial interests of the country. The press in general is of the same opinion, and many able articles on the subject have recently been published. The *New York Times* has treated the matter in a fair and business-like manner, and we cordially recommend its utterances on the subject. The recent extensive failures in the leather trade, and others of less importance, have largely conduced to a revival of the discussion of the necessity of a national bankrupt law. This proceeds in part from a feeling that there is about to be a series of commercial failures of very much greater extent than in ordinary times. We do not regard the feeling as justified, for there is no evidence that the legitimate business of the country is overdone, or that there is such an undue expansion of credit as would lead to any general insolvency. On the contrary, the conditions which precede such a state of things, and which may fairly be considered necessary to it, are conspicuously absent. There has been for some time a notable want of anything like speculation, not only in nearly all regular lines of business, but in stocks. Those who are prone to look on the dark side point to the great quantities of watered securities that have been put upon the market, and these have certainly been excessive. But there is no lack of capital so far to fairly sustain them, and it is very well known that speculation in them has not extended, in any great degree, to the general business community. On the contrary, it is quite likely that they have afforded only a natural and not wholly unhealthy outlet for the regular accumulation of surplus capital, which now goes on in this country more rapidly than it has ever done before, and more rapidly than is generally understood. The character of ordinary trade for the past two or three years has been reasonably cautious, and the reports agree that it has been rather from hand to mouth than marked

by that feverish venturesomeness which brings about a collapse of credit. There is no adequate proof that a bankruptcy law will be needed by any extraordinary spread of insolvency for some time.

Yet there are always reasons why, in a great trading community like our own, divided up into more than two-score State jurisdictions, bankruptcy, whether contracted or extended, should be regulated by a national law. A national law is uniform, and if it be a good law it secures the same justice in the same way for debtors and creditors in all parts of the Union. It gives the same security to all classes, and enables the sellers and the buyers all over the Union to make their calculations with a like degree of certainty. It reduces the danger from bad debts on the one hand, and from over-greedy creditors on the other hand, to a minimum, and gives to the trade of the country at once a steadiness and a safety which are of the highest importance. The value of such a law, however, depends upon the principles on which it is based, and if these be mischievous or mistaken, the law is as powerful for harm as it ought to be for good. The last bankrupt act was unquestionably an instance in point. It was generally denounced by the business community as an ingenious device for encouraging dishonesty and for enabling careless or swindling debtors to escape the consequences of their conduct. It did not protect honest debtors or honest creditors, and the abuses attending its administration were scandalous. We do not want another law of this sort. No law at all would be far better.

The primary, and in fact the sole, object of a bankrupt act is to enable an honest but unfortunate insolvent to obtain a release from his debts on surrendering all his property to his creditors. Its administration, therefore, naturally and necessarily divides itself into two parts, the first of which is intended to make it certain that the insolvent is honest, has become insolvent through no serious fault of his own, and is prepared to really surrender all his property. The second part of the administration of the law should have for its aim the equitable distribution of assets with as little loss either from delay or costs or mismanagement as possible. This simple analysis of the purposes of the law indicates the respective shares of the Government and the creditors in its administration. It should be the part of the Government, through agencies essentially judicial in their character, to ascertain that the debtor has been honest and has managed his affairs with that reasonable prudence which alone is consistent with honesty, and until this shall have been clearly established there should be no release from his obligations, whether with or without the consent of a majority of his creditors. This is a function which cannot be trusted to creditors, who are naturally more anxious to settle with the debtor on the best terms that can be got than they are to maintain the general standard of commercial integrity. It is, however, a function not only important, but indispensable, and the Government has no right to surrender it to others or to neglect to perform it itself with the greatest possible energy and care.

This having been secured, however, and the honesty and good faith of the debtor having been clearly ascertained, the distribution

of the assets and their management may, and ought to, be made by the creditors, through properly selected agents, with only such supervision by the Government tribunals as is necessary to secure equity between the creditors. Both these principles are now generally recognized in commercial nations, and they should unquestionably be made the basis of legislation by Congress. Any considerable departure from them, however, would make a national bankrupt act an injury and a nuisance.

Peripatetic Swindlers.

THERE IS scarcely any line of legitimate trade that offers so many opportunities to unprincipled adventurers and swindlers to exercise their talents in as the jewelry business. Speculators and swindlers are constantly devising ways and means for deluding the unwary under cloak of being dealers in jewelry or kindred goods, and the legitimate trade not only suffers great loss of custom from their "tricks and their manners," but have to bear the stigma of being engaged in dishonest practices. Not only is the trade injured in reputation by these adventurers, but retail dealers frequently find their market for goods seriously demoralized by reason of its having been flooded with spurious and worthless goods, made expressly to deceive the ignorant and the unsuspecting. Among the worst of these unprincipled adventurers is the traveling auctioneer, who goes about the country with a stock of spurious goods which he sells to the lowest bidder as genuine. Their plan is to visit a city or village, hire a vacant store, and therein exhibit their cheap and worthless stock. The residents of the place and the farmers in the vicinity are then notified by handbills and circulars, that there is to be a "bankrupt sale of a stock of choice jewelry, plated ware, cutlery, etc." Assurances are freely given that these goods constituted the stock of some large dealer in a distant city who has just failed, and a peremptory sale of the goods has been ordered. Occasionally these auctioneers claim to represent some manufacturer who has been obliged to take this mixed stock to secure an amount due him, and a quick sale is necessary. The auctioneer swindle has been quite extensively worked, and the auctioneers, strangers of unknown reputations, have induced people to buy their cheap and valueless goods who would scarcely think of spending a dollar with the resident dealer, well known in the community, for fear of "being swindled." In many instances these auctioneers are backed by some eastern manufacturers of bogus goods, made expressly for this business; or by some western jobber in such goods, who keep the auctioneers stocked up with whatever they require. Their gold goods, so-called, have no right to be so designated, for the reason that so little gold enters into their composition that it would be a perfect surprise to it if it were ever detected by the process of assaying. Their plated goods are made of cheap, trashy stuff, having the thinnest possible film of silver plating that can be deposited thereon by the electro-plate process. Their other goods are all of the "skin" kind, having no intrinsic value whatever, for when a few days' wear takes away the gloss, what remains is useless. Yet these auctioneers work off large quantities of this stuff every year, the profit on which is very large. The American people, as Barnum says, delight in being humbugged; we may add that they also delight in being swindled, otherwise they would not be caught time after time, and year after year, by the same old dodge and the same artful dodgers. A safe rule to follow is to have nothing whatever to do with auctioneers who sell jewelry unless you know that the stock they offer was the legitimate stock of a legitimate dealer. Occasionally a jeweler is obliged to sell his stock at auction, but when he does so he is very careful to give the public an honest description of his goods. It is the peripatetic, unknown, irresponsible auctioneering adventurers that are to be avoided. It is safe to regard all such as swindlers and their goods as bogus, made, like Hodge's razors, to sell, and whoever buys is sure to be badly bitten.

Another class of peripatetic adventurers who are to be avoided are the vendors of eye-glasses and spectacles. These chaps usually advertise themselves as "celebrated opticians," whose knowledge of the human eye and its many defects, is, like Captain Cuttle's watch, which being set ahead a quarter of an hour in the morning and fifteen minutes in the afternoon, was "excelled by none and equalled by few." They advertise liberally in the local papers, and so gain the favor of the editor, and frequently announce free lectures on "diseases of the eye." Getting an audience, they recite a lot of well known facts regarding the eye, to be found in any text-book on optics, and conclude by offering for sale eye-glasses and spectacles for which they claim especial virtues. A feature usually dwelt upon is the exceeding cheapness of their goods, offering spectacles for one dollar which, they assert, the local dealer would charge them two and a half or three dollars for. They find persons, generally those past middle age, and frighten them by assuming to find defects in their eyes which bid fair to render them blind at an early day. "Madam," said one of these peripatetic quacks to a lady whose eyes he was examining, "the condition of your eyes is alarming; they are not equal in their powers of vision, consequently one is doing the most of the work; the result will be that one will be destroyed from lack of use and the other from overwork; this must be remedied; the lazy eye must be brought to pull its share of the load; here is a pair of glasses especially designed to remedy such defects, one glass being intended to hold one eye in check and to develop the full working capacity of the other; only two dollars for this pair that a jeweler would charge you five for." If the old lady had thought to ask him how many persons have eyes precisely alike, the quack would not have told her that there were very few, but would have invented more lies for her benefit. But these fellows, by their varied and ingenious devices, manage to sell many glasses at good prices that are in fact worse than worthless, for they are so inferior that they are positively injurious to the sight of whoever uses them. Such glasses as they sell can be bought for a few cents each from the manufacturers, and are so poor in quality that the local dealer would be ashamed to have them in stock. Yet people will pay these swindling quacks one, two or three dollars a pair for them, when the regular dealer would be glad to order them for them at twenty-five cents. But great is humbug and immense is quackery. All such itinerant scamps should be prosecuted for obtaining money under false pretences. The law ought to be broad enough to cover their arrest and imprisonment on the *prima facie* evidence of their advertised claims and bogus endorsements. They are unprincipled swindlers, who are robbing the public at every opportunity.

A good way to circumvent these swindling auctioneers and optical tramps is for the local dealers in the places where they advertise to appear, to get out circulars and scatter them broadcast through the community, reciting the facts above set forth. If the names of two or three dealers and well-known citizens are attached to such circulars, they are sure to have the desired effect. We have known instances where this has been done with the effect of driving the peripatetic swindlers out of town before they opened up their spurious goods. Extracts from articles that have appeared in THE CIRCULAR on this subject have been inserted in the local papers, side by side with the advertisements of the quacks with good effect on several occasions. When the public is placed on its guard in this manner, it is usually sharp enough to avoid being swindled.

Abuses of the Memorandum System.

THERE HAS grown up in the jewelry trade in the United States largely during the past dozen years, a condition of affairs involving a serious evil not known to any other leading branch of business—an evil so contrary to commercial precedent, and so burdensome in its demands upon jobbers, that it must speedily be restricted or

abolished. What was originally accorded as a special "privilege," in rare cases, for the sale of special articles, has become an "abuse" of elaborate proportions and now controls an immense percentage of transactions. The times have changed; the rules of trade have been reversed. Formerly orders meant "sales," and goods shipped by jobbers were definitely sold. To-day the bulk of goods that go out into the country are sent subject to the delay, expense, and dissatisfaction which the "Memorandum System" involves. Probably few retailers have given thought to the extent of this abuse, so general is the privilege now regarded as a matter of course.

When the memorandum accommodation to retailers began, it was reasonably expected by the jobbers that the goods were ordered with assured prospects of a sale; that they would be carefully handled, and returns promptly made. The express charges were usually borne by the retailers. From small beginnings the system has expanded until it is now taxed to furnish goods for every ordinary and extraordinary occasion. Not merely the odd, the special, and unique article is now ordered on memorandum, but selections and assortments in every line, from cheap plated jewelry to chronographs and diamonds. Memorandums, originally a courtesy, are requested (even insisted upon) as an inalienable right, and for every purpose, from showing a customer a diamond stud, to making a \$10,000 display at a fair. Chronographs are ordered to hold "during the races," and once or twice a year many dealers expect to add a thirty days' exhibit to their stock. Jobbers complain that this is an unfair exaction; that if lavish selections are not sent, customers are offended, and prompt reports are no longer the rule but the surprise. Goods are kept from two to six weeks, and even three months. Any casual excuse for the delay is deemed sufficient, but the jobber is deprived of goods and the opportunity to sell those goods to others.

We hear, too, of great neglect in packing on the part of the retailer, so that damage occurs, putting the jobbers to expense. We know of one actual instance where two movements in boxes, two gold cases, some gold chains, and several pieces of jewelry were shipped back from memorandum orders without any packing paper,—loose in the box, like cobble stones.

Wholesale dealers have genuine cause to feel that the memorandum abuse is overdone. The system presents evident advantages within reasonable lines, and for these advantages the retailer should reciprocate the courtesy of the jobber, but the continual arrogant demands and pernicious practices of selfish and unthinking dealers brings the system into discredit and creates the necessity of a revolution in methods.

Those dealers in the trade who are considerate, discriminating and careful, can with difficulty comprehend the extent of the abuse. It is declared that a leading dealer in Michigan never buys a dollar except through the friction of memorandums and consignment. A retailer in Texas (widely known for his proclivities) comes to New York, "selects" goods from various houses, has them all shipped on memorandum, and, after sixty days, returns in bulk twenty-five or thirty packages to one house, with the request to deliver as directed. These packages usually contain about two-thirds of the goods originally selected. The complaints are legion of fine Roman finished jewelry, scratched, bruised, and dented; of fine watches broken; of cases injured; of chains roughly handled; of onyx goods chipped; of fancy stones broken; of goods "not found" and repudiated on the bill; of expressage shirked by the retailer; of manifold delays and vexations in getting the returns, and innumerable inconveniences and irritations from which the trade should be exempt. We voice the emphatic sentiment of the manufacturing interests when we criticise the abuse to which they are subjected, and we desire to remind indifferent dealers that their methods must have one inevitable result: They will "kill the goose that lays the golden egg." The existing condition of affairs have been brought forcibly to our notice, and leading firms are unanimously resolved that some measures are necessary to restrict this evil. To repeat accounts given us of the extent to which memorandum orders are carried, would pass the

limit of THE CIRCULAR, but we will quote briefly from the experience of a representative house. Said the head of the firm to us: "We have customers on our books who rarely ever buy a bill outright, and if ordering a No. 7 in a nickel case, want it on 'approval.' Our memorandum orders now embrace about $\frac{3}{4}$ of the number we receive, and the value of goods shipped daily will often be four times the amount of sales. We have had a memorandum of \$1,800 kept three weeks and returned with \$2.70 sold. Men who want two or three gold cases, build up orders thoughtlessly, that call for fifty to seventy-five, but the small retailer who has a customer 'talking of buying a fine watch,' and orders a dozen at \$350 to \$450, is, perhaps, the champion memorandum fiend. He also invariably wants our stock of chronographs during the races and thinks he could sell some. When we cut his order down to one \$450 Jurgensen, it goes out, stays out on a hope deferred basis, and is often returned broken. We have just lost \$17.50 repairs on an imported fly-back watch. It also cost us recently \$12 to make over a heavy pair of Roman bands dented while out on memorandum—(refinishing is a constant requirement.) In fact we run a regular sinking fund for express charges and refinishing goods. Many orders are needlessly extravagant, but we cannot discriminate and reduce them, as the trade expects lavish quantities sent, or we lose our customers. A recent order called for twenty pairs of Roman and diamond bracelets at \$100 to \$150—goods made usually in single lines. The combined leading stocks in the city could not have furnished them. We sent seven, and *one* was sold. Read this letter received among to-day's mail:

* * * * *

"I want you to send us on memorandum a fine assortment of ladies' and gent's 14-k. gold watches, K.W. and S.W.; also a fine line of gent's 18 and 16 size in Boss cases, O. F. and Htg. K. W. and S. W.; men's and ladies' guards, gold and plated, gent's fancy and curb vests, (two fine link); gold 14-k. vests; a few silver cases and Hampden movements; neck chains, charms and lockets. Our fair comes off next week.'

"Our friends evidently do not reflect that this is an extensive order, and that they are one among 10,000 who all contribute to empty our safes and yet yield us little compensation for our expense and generosity. Apart however from such casual orders, here is an account for last year with one of our customers, which illustrates the drift of business. During the year he bought about \$18,000. He had on various diamonds memorandums \$44,000, of which he bought \$5,000. His constant memorandums of watches, chains, and general jewelry and bric-à-brac, amounted to \$50,000, of which he paid for \$6,000. Our traveler sold him \$3,000, and he bought \$3,000 over our counter; the balance was direct sales orders. Many small accounts of \$1,000 to \$3,000 yearly, are the results of a continuous stream of memorandum goods, probably amounting to twenty times the purchases.

"On the first of August, after unusual efforts to "clean up" our books, we still had open between three and four hundred memorandum accounts which drew from our stock 495 gold cases, 825 movements, 22,000 dwts. of chain, and diamonds and jewelry amounting in aggregate value to \$50,000. Our special holiday memorandums last Christmas consumed a variety and amount of goods equivalent to the stock of the largest dealer in the country outside of New York city. Our loss in depreciation of goods damaged, expressage and interest, exceeded the yearly sales of the leading retailer in any town of 20,000 inhabitants. These demands upon us are wrong; they increase the cost of business; they amount to an abuse that cannot be endured; and the memorandum system must be restricted or abolished."

Said another leading jobber: "Besides the drain of goods, we are treated constantly to unreasonable complaints. Few dealers seem to appreciate these favors, and consideration for the jobber is almost unknown. Orders are carelessly worded. To serve our customers we send on selections four times the assortment needed, and get a growl about goods 'being unsatisfactory,' 'none suited.' Packages

are returned to us without name, or letter, and it is with difficulty that we can tell where they are from. If delay occurs in finding out, we are the subject of complaint. If a month goes by and we politely ask for a report, we are thought to be in a 'great hurry for our goods.' If we suggest dividing the loss by damage, we are considered 'small.' If a customer can gouge us in no other way, he deducts the express charges from the bill and cash discount for goods he has held sixty days on memorandum."

The average retail jeweler is not a trained merchant, and his customs are not business like, but we are glad to say that to the average dealer there are pleasing exceptions. In refreshing contrast to the class of men who form the subject of comments, and whose abuse of an indulgence strongly tends to withdraw the liberality of the jobbers, are the few, but highly appreciated gentlemen in the trade, whose trained experience and regard for the courtesies of mutual accommodation, never impose upon an overtaxed generosity; whose memorandum orders are discriminating and reasonable; who return goods not sold in carefully packed condition; who share us the expense of transit, and purchase in proportion to their orders; who manifest in their correspondence with the wholesalers a just sense of recognition for efforts made to serve them; whose dealings are a constant gratification and who may confidently rely at all times upon the enjoyment of every favor which it lies in the power of the wholesale trade to extend. It is to be hoped that efforts now being made to restrict the memorandum abuse to reasonable limitations may be successful.

WE HAVE alluded heretofore to a certain class of western jobbers who strive to serve two masters by selling to retail dealers and to the outside trade also. Their plan is to send out two travelers with one trunk, or, possibly, they indulge in the extravagance of supplying each with a trunk. These travelers visit a town, and one of them immediately calls on the retail dealers, selling them what goods he can, and representing that he never, no, never, sells to outsiders. When he has stocked up the dealers, the other traveler takes the same samples to the outside trade and represents that he does not care to call on the local jewelers, but prefers to sell to the outsiders. In this way the town is well stocked, and the legitimate retailer finds his market forestalled. Some eastern manufacturers have adopted a similar policy of dealing with jobbers, retail dealers and outsiders. One traveler attends to the jobbing trade, another to the outsiders, and a third to the retail dealers. By this means the jobber is robbed of his customers—the retail dealers—and these are brought into direct competition with the illegitimate outsiders. Why, it is asked, have not the state associations, that were to be all-powerful in correcting abuses, remedied these evils? This style of doing business has been going on for several years, and the houses that are doing it ought to be known to most of the officers of these associations, yet no effort has been made to prevent it. The fact is, these associations that started out full of promise have been strangled in their infancy by the overwhelming ambition of a few men, who have used them for their own selfish purposes, to glorify themselves, and for their own aggrandizement. For all good they might have done their power is lost, their influence having been absorbed in promoting the ends of their manipulators. The few well-meaning, honorable men, who were identified with them at first, have gradually fallen away from them, till now there is scarcely one of these organizations that can muster a corporal's guard of members to attend an annual meeting. There was a splendid opportunity for organizations of retail dealers in the various states to make themselves a power for good in the trade, and, had they been properly directed, the evils now so loudly complained of could all have been eliminated from the business. In particular, organized action would have prevented the outside trade ever assuming formidable proportions, but, owing to the inefficiency of the state associations, the illegitimate trade is now so firmly established that it cannot be overcome. Instead of

protecting the retail trade, these associations have been used by selfish individuals directly in the interests of those who have sought to destroy the rights of retailers. Having accomplished their object in this respect, the state associations may as well be abandoned in name as they have virtually been in fact.

WE HEAR of certain papers that claim to be published in the interests of the trade, that are striving to "run with the hare and hunt with the hounds" at the same time. In other words, they represent to the jewelry trade that their circulation is exclusively among retail dealers, and that no "outsider" can get a copy of it; then they go to those who cater to the outside trade and represent that they don't care for the retail jewelers, but that their paper has a large circulation among crockery dealers, milliners, gent's furnishing goods dealers, and others who are noted for carrying lines of jewelry in direct opposition to the legitimate retail dealers and the best interests of the trade at large. Convincing proofs of this double dealing can be produced if desired. Another trick of these Janus-faced publishers is to have a sliding scale of prices for their advertising columns, by means of which they fix their rates to suit their customers. We know of instances where one advertiser pays less than half of what is exacted from others for the same space and equally desirable position. The publisher goes upon the theory that half a loaf is better than no bread, and if he cannot get what he wants for his space he will take what he can get. This may suit him, but how about those who are paying two or three times as much as their neighbors? Advertising space has a fixed and positive value, based upon the character of the publication, the number of copies circulated, and the class of persons reached by it. A circulation mainly among the tenement houses of New York might be of value to a sporting or police news paper, but of little use to a manufacturer or jobber of jewelry. A publisher knows the value of his space better than anyone else, and the lowest price he is willing to accept for it may be taken as the full measure of value. We call attention to these idiosyncrasies of some journals that would be glad to be recognized as identified with the jewelry trade, that advertisers may be on their guard, and that retail dealers may not be deluded into patronizing papers that pat them on the back with one hand and stab them under the fifth rib with the other by aiding the competition carried on by outsiders.

THE DEMORALIZATION in the gold chain trade still continues. Prices have been cut to a most ruinous extent; in fact there are no "bottom prices," for no manufacturer can name a figure so low that another one won't "shade" it a trifle. Buyers have found out the trick of it, so when they want chain they go to a manufacturer and ask, "What is your basement price for 14 karat chain?" The price being named, he says: "Oh! I know a manufacturer who will put a sub-cellar under that." And so he plays one maker against another till he gets his chain for what the metal in it is worth, with no allowance for the cost of manufacture. The buyers can stand such a fight if the makers can, but what is such fun for the boys is likely to result in injury to the frogs. This ruinous competition is most unfortunate, for the natural result is deterioration of quality. In fact this result has been reached, and a considerable of the chain now made will not assay up to standard quality. However, the makers are not entirely to blame for this, for the jobbers are so determined to have low-priced chain that they have come to disregard quality to a very great extent. What they demand is "style" and cheapness, and in order to meet this demand some of the makers have lowered their standard of quality. It is unfortunate for the trade when competition is carried to an extent that compels manufacturers to either deteriorate their goods or to sacrifice their profit. The country is the most prosperous when every industry is conducted at a profit and capitalists and working-

men realizing a fair return on their investments of money and labor. At such times each industry is a help to all others, and the reverse of this proposition is true, that when one line of business becomes unprofitable other kindred enterprises are more or less affected disastrously by it. It is much to be regretted that the sensible business men engaged in the manufacture of gold chain cannot agree upon some plan that is calculated to place their business once more on a good, solid and profitable basis.

THE QUESTION of adopting what is thought would be a simplification of the common method of computing time has been under consideration for some time by railroad officials. The proposed system contemplates an abolition of the twelve hour plan and an adoption of reckoning from one to twenty-four o'clock. This plan, it is claimed, would prove of the utmost value in the conducting of railroad interests, and, it is said, has already been put in practical use by a couple of western roads. A majority of the railroad superintendents who have been approached on the subject decidedly object to the projected mode of numbering the hours of the day from one up to twenty-four. They take the ground, and with a good deal of reason, that such an innovation here would breed endless confusion. We do not wonder that they feel strongly on the subject. There are enough railroad accidents in the country without adding to the number by the introduction of any new cause. Think of saying thirteen o'clock, and then, in order to understand what it means, mentally calculating that it must mean twelve o'clock plus one. Talking of mean time, we should call this very mean time indeed, which had to be comprehended by incessant arithmetic. The advocates of the twenty-four hour o'clock system are less reasonable than the phonetic enthusiasts who want to break up entirely the present mode of spelling. What is called a reform is sometimes an offence. It is certainly an offence when it increases the chance of accident and introduces inextricable confusion. It seems to us that the old-fashioned A. M. and P. M. are good friends who do not deserve to be summarily kicked out of the house. Besides, though we know a day is twenty-four hours long, it does not really seem so long when we ingeniously break it up into two little days of twelve hours each.

THE BRITISH House of Commons has passed a bankruptcy bill the conditions of which will be noted with interest here. American bankruptcy legislation in the past has been largely based on English precedents, and now that England looks for an example to the severer laws of France, it is well to see what course she takes. It is said that the new bill represents to some extent a compromise between the official and non-official systems. By means of this compromise the creditors get control of the estate, and the court deals with the debtor. No private arrangement is allowed. Every debtor who fails must go into bankruptcy, from which he can only come out after his affairs have been subjected to the severest scrutiny of the court. The limit of value which shall not be seized by the sheriff under an execution has been raised from \$50 to \$100, and thus a better protection is afforded to the effects of men in humble circumstances. The experience of England under the new law will be a guide to our own legislators when they come, as come they must at no distant date, to try their hands again on a national bankruptcy law.

WE DESIRE to direct special attention to the very valuable articles that have appeared in our columns recently on table utensils, by Mr. J. W. Miles. A more interesting series of articles on this subject has never been written. Mr. Miles is thoroughly famil-

iar with what he writes about, and his descriptions of the varying fashions in table furniture are interesting and valuable. One would scarcely think much could be made of such a subject, but in the hands of an expert, who is also an intelligent and pleasing descriptive writer, it becomes interesting to even the casual reader, and of value to every one identified with the trade. We cordially commend them to our readers.

The Jewelers' League.

President, GILBERT T. WOGLOM.....Of Woglom & Miller.
 First Vice-President, JAMES P. SNOW.....Of G. & S. Owen & Co.
 Second Vice-President, HENRY HAYES.....Of Wheeler, Parsons & Hayes.
 Third Vice-President, WM. C. KIMBALL.....Of H. F. Barrows & Co.
 Fourth Vice-President, AUG. KURTZBORN.....Of L. Bauman Jewelry Co. St. Louis, Mo.
 Secretary and Treasurer, WILLIAM L. SEXTON.....Of Sexton & Cole.

EXECUTIVE COMMITTEE.

JOHN D. LYON, *Chairman*.....Of Lyon & Hardy.
 JOSEPH B. BOWDEN.....Of J. B. Bowden & Co.
 JAMES D. YERRINGTON.....Of J. D. Yerrington & Co.
 ROBERT A. JOHNSON.....Of Colby & Johnson.
 SAMUEL W. SAXTON.....Of Saxton, Smith & Co.
 CLEMENT B. BISHOP.....Of Carrow, Bishop & Co.

EXAMINING FINANCE COMMITTEE.

CHARLES G. LEWIS.....Of Randel, Baremore & Billings.
 CHAS. G. ALFORD.....Of C. G. Alford & Co.
 GEORGE R. HOWE.....Of Carter, Sloan & Co.

THE JEWELERS' CIRCULAR is the *exclusive* official paper of the Jewelers' League, and has been selected for the publication of all matters of interest pertaining thereto. Letters or inquiries pertinent to its business or purposes, and which might interest the trade or inquirers, will herein be answered. Address *Jewelers' League, Box 3,444, P. O., New York*, or the office of THE CIRCULAR.

The members of the League must be either nomadic in their inclinations else they have an "excelsioric" ambition to better themselves, for during the last year over 1,400 members have advised Secretary Sexton of changes of addresses.

During the summer months a movement was made by the prominent organizations in this State to show their appreciation of the services of Hon. Elbert O. Farrar, of the Second Onondaga District, in introducing and carrying to its final enactment, Chapter 175 of the Laws of 1882, embracing features of vital importance to *bona-fide* Mutual Benefit Associations, and effectually repressing those which assume the name with intent to prey upon a confiding public. Most of the officers and several active members of the League joined in furnishing a sum of money with which, added to a sum from the Bank Clerks', Commercial Travelers' and Mercantile Benefit Associations, a massive seal ring was procured, with appropriate inscription and seal engraved thereon, together with a beautifully engrossed and framed letter reciting the service rendered and the purpose of the testimonial. This has since been acknowledged by the recipient in a fitting and appreciative reply.

The regular meeting of the Executive Committee was held on Friday, P.M., September 7th. There were present Chairman John D. Lyon, Saml. W. Saxton, Clement B. Bishop (of whom it is a pleasure to announce a complete recovery from the shock and injury experienced in a recent railway accident), Joseph B. Bowden, Secretary Wm. L. Sexton, Vice-President Wm. C. Kimball, and President Woglom, all in good health and on the alert for the duties of their positions.

The following named 66 applicants were admitted to membership:

J. F. W. Woidt, F. M. Welch, J. Unger, T. Simpson, E. F. Sanford, R. H. Ryan, I. W. Rauth, W. H. Morris, A. McLeod, G. Lewis, F. W. Kroeter, R. Kranehl, T. H. Kavanagh, C. L. Hines, F. Hill, E. D. Hicks, F. A. Frey, H. W. Francis, E. H. Eckel, W. N. Dickinson, C. A. Cooper, W. A. Bryant, C. H. Brahe, R. W. Adams, O. N. Wright, New York City; C. Schwitter, W. E. Bidwell, Brooklyn, N. Y.; A. J. Nelson, Massena, N. Y.; F. C. Maynard, Saratoga Springs, N. Y.; J. H. Clark, Batavia, N. Y.; J. H. Bullard, Watertown, N. Y.; J. B. Wilkinson, E. Rosenheim, M. Newhouse, J. P.

Kennedy, F. R. Grimes, R. A. Greifenhagen, Chicago, Ills.; A. E. Whitney, G. H. Morrill, Boston, Mass.; E. L. Smith, Mansfield, Mass.; J. F. Kivlin, Plainville, Mass.; J. H. Conner, Lynn, Mass.; F. F. Bell, Boston, Mass.; F. L. Bassett, Ware, Mass.; W. Schmander, Jr., A. Milne, J. V. Diefenthaler, B. F. Rodgers, Newark, N. J.; H. R. Mitchell, Louisville, Ky.; A. K. Lyon, Lexington, Ky.; W. W. Bradley, Newport, Ky.; M. T. Graham, Nashville, Tenn.; A. Johnson, Terre Haute, Ind.; C. A. G. Steman, L. Lemkul, A. H. Fetting, Baltimore, Md.; E. F. Robinson, Ellsworth, Maine; G. E. Thompson, Lincoln, Neb.; S. Linz, Sherman, Texas; H. E. Buechner, Cheyenne, Wyo.; F. White, Weatherly, Pa.; G. J. Corey, Middletown, Conn.; J. L. Duke, Fayetteville, Ark.; E. Geist, St. Paul, Minn.; R. J. Girard, Milford, Pa.; H. M. Wright, Detroit, Mich.

One application was rejected, one resignation was accepted, and twenty-two members were dropped from the roll for non-payment of assessment No. 20 within the prescribed limit of time; satisfactory explanations of their delinquency having been given they were re-instated after having paid the assessment. Ten applications were "tabled" for further investigation. The Treasurer reported in the general fund \$3,545.25, in the benefit fund \$5,143.30, and \$50 government bond in the permanent fund.

This \$50 bond mutely appeals each month to the officers for one or more other bonds to keep it company in its lonesome seclusion. It was presented to the League by two members for the permanent fund, and if any other members desire to do the same thing the two members referred to will cheerfully advise as to the course to be pursued to get it into the permanent fund. No stamp need be enclosed to the office of THE JEWELERS' CIRCULAR for such advice by return mail.

Five requests were granted for change of beneficiary.

Properly attested proofs were presented of the death of Charles E. Livermore, with Robbins & Appleton, Boston. He became a member (No. 377) in April, 1879, and died at the age of 40. His sister, Elizabeth B. Livermore, is his beneficiary, and to her was forwarded, on 8th of September, a check for \$5,000, being the first payment of that amount. The membership is now sufficient to pay \$5,000 benefit for each death, and the members of the Committee felt a justifiable pride in being able to bestow, on behalf of the members of the League, such a munificent sum, a gratifying contrast with the sum (\$459.80) paid for the death of the first member in January, 1878. Assessment No. 21, of two dollars on each member, was ordered, to replenish the benefit fund, notice of which has since been sent by mail to each member.

The League now numbers 2,792 members.

The beautiful style of handwriting in which the names and addresses of recent members appear on their membership certificates is that of Miss Vaughn, the efficient office assistant of Secretary Sexton.

The case of President Woglom, on behalf of such subscribers to the Chicago Relief Fund as presented their respective interests in it to the League, *versus* Trustees Enos Richardson and Henry Randel, for its possession, is still being pressed as rapidly as the multiplicity of detail in the case will admit. Up to this writing there have been held 14 sessions before Referee Edward M. Shepard of this city, 7 sets of letters testamentary of deceased subscribers have been proven, 90 assignments by living subscribers have been also proven, 30 witnesses have been examined, the evidence on behalf of the League is now all in, and the defendants will be heard at the next session on October 5th.

President Woglom frequently speaks to us of the able and willing assistance which has been rendered to him in the prosecution of this onerous case by each member of the League upon whom he has called, and especially grateful is he to many of the subscribers, who not only donated their interests but besides, in every instance at considerable expenditure of time and in many instances expenditure of money, kindly attended before the referee when requested to give their testimony. He has found many good hearts and large ones in the jewelry and kindred trades.

The officers and members of the Executive Committee who were the associates of George W. Shiebler, the silversmith, during his term of service on the said committee, were, on the 11th ultimo, each the pleased recipient of a solid piece of silver, richly ornamented in antique *curio*, with a motto and the initials of each one's name quaintly graven thereon, the product of the *atelier* of the donor, who thus happily intended to commemorate the pleasant hours and the friendships renewed and strengthened during the transaction of the business of the committee. We trust that the same kindly and unifying spirit which has heretofore existed between the officers, and the officers and members, may always prevail.

Table Utensils.

[BY JOHN W. MILES.]

Continued from page 244.

THE SLUGGISH acceptance of an article which is to us so eminently necessary was probably due in a great measure to the difficulty of acquiring skill in its use, for it must be acknowledged that the fork is an awkward utensil in the hands of those unaccustomed to it. The experience of a novice would probably prove similar to that of the Tahitian who, when he "tried to feed himself with a fork, could not guide it, but, by the mere force of habit, his hand came to his mouth, and the victuals at the end of the fork went away to his ear."

The relics of the 14th, 15th and 16th centuries, contained in the different museums and collections, include some few specimens of art work in table utensils. Both knives and spoons were made equally as ornamental as the forks, and in some cases knives were made to match the forks. In figures 30 and 31 we have a fork and knife matching each other. The handle of the former is of silver, engraved and chased, and the tines are of steel. The knife has a



FIG. 30.



FIG. 31.

blade of steel of a peculiar shape, denoting a particular purpose; possibly for cutting bread. Another peculiarity of this illustration is that although they belong to the 14th century the character of the ornamentation is that of two centuries later. A knife of the 15th century, attributed to Pallaiolo, has a handle of silver parcel gilt, divided into four compartments on each side. The illustrations in low relief filling these spaces on one side betray a singular blending of Christianity with the heathen mythology, the subjects being David and Jonathan; David and Abigail; the Judgment of Solomon, and the Judgment of Paris. The reverse compartments are filled with classical warriors. Niello work was extensively used, and many of these objects were thus decorated. Both wood and ivory were also employed in the construction of handles, evincing, in their shapes and carvings, much delicate workmanship. Ivory was very rare in the 13th and 14th centuries, but it became more abundant in the 16th century, and was very extensively used in the manufacture of small objects. Figures 32, 33 and 34 will illustrate the skill acquired by the workers in ivory during the latter century, and also exhibit some beautiful engraved and chased work upon the steel blades. This decoration of the blade may have been produced by etching, since that art was introduced by Dürer about this time. Certainly we need not look for anything crude in art during an age that boasts a

Benvenuto Cellini and many other artists of high rank. To the 16th century belongs the Apostle spoon, of silver and gold, with the han-



FIG. 32.



FIG. 33.



FIG. 34.

dle terminating in the figure of a saint, figure 35. These, among other things, are mentioned in the will of Amy Brent, 1516, who



FIG. 35.

bequeathed "thirteen silver spoons with the figure of J'hu and His twelve apostles." There is one of silver gilt in the South Kensington Museum belonging to the Bernal collection. This is surmounted with an upright figure of St. Thomas with his emblem. The stem is decorated with cartouche work, and the bowl full of birds embossed and chased with foliage. There were twelve or thirteen of these in a set, one for each apostle, and they are still manufactured in silver although the sale for them is limited. It will be observed that the bowl is almost a perfect oval, differing from our modern bowls, which are more nearly egg-shaped. Many of the spoons of this date were richly embellished with gems in addition to the embossed and chased work. Handles of coral and bowls of boxwood or segments of the cowrie shell were not uncommon. Rock crystal was also used mounted in silver and inlaid with gems. An Italian jointed fork of silver, figure 36, belonging to the same period and in the Bernal col-



FIG. 36.

lection, will give some idea of the elaborate ornamentation that was applied to these articles. It has a fluted stem carefully chased, and with a kneeling statuette, representing the Princess of Lybia, at the end. Upon the broad surface of the handle is a tiny representation in complete relief of St. George and the dragon. The two sides are set with garnets.

From the collection of forks with wooden handles we select one from Germany, figure 37, with prongs of silver, and belonging to the

17th century. The handle is inlaid with silver. The processes of overlaying, inlaying, enameling and gilding had previously attained a high state of perfection and were used in many fanciful figures, the artists being then, as now, compelled to continually originate new designs. This, however, ought not to have been very difficult, when we consider the limited manufacture and the time necessarily consumed in the production, which allowed the brain to recuperate and gain power for subsequent efforts. As a rule, all the utensils and articles of adornment manufactured during the Middle Ages bore a distinctive character of individuality. The plate and ornaments of a



FIG. 37.

nobleman were made after designs especially for him, and it does not appear that these were duplicated for other people. The artisan, who was also an artist, was, during the construction of these objects, attached to the household and under the protection of his patron, a relationship that often extended through many years of service. The productions would, therefore, become not only the embodiments of a single genius, but also the property of a single person, and the skill that fashioned one article would be exhibited in the entire collection. This would give to the plate of each nobleman a special character of personality, which was very popular. In many of the mythological or allegorical figures that decorated the silver work of that period the faces were exact portraits of famous court beauties or other celebrities whose prominence was deemed sufficient for such a distinctive compliment. This desire for exclusive designs belonged to the entire countries of France and Italy, and permeated as far even as equatorial Africa, where ornaments for the hair and person were embellished with cameo portraits of the wearer. Under this system of non-duplication the decoration and design of each separate piece of plate bore its own legend of sentiment or story, and although the minor articles of the table displayed little room for any great exhibition of artistic expression, they were far from meaningless in design, and were no less rich and varied than the larger pieces.

Leather cases were used for almost everything, and often an outer sheath to protect the inner case. The traveler carried in one case a large knife, a fork, one or more small knives, a pair of pincers, a file for sharpening, a pair of scissors and a cork-screw, and he was compelled of necessity to carry these things, since he was more than likely, in his wanderings, to visit numerous places where these articles were not in use. This custom was followed by the English gentry as late as the 18th century, while as early as the 14th century we learn that Gaston de Foix carried a small knife for table use upon his person, and this article, with a small golden ring, was used at his death as a token to open the gates of the castle of Orthés.

A fork of silver, used by an Italian traveler of the 18th century, figure 38, does not differ in general character from those which had



FIG. 38.

been previously in use, except that an additional tine was supplied. The tips of the handles were still ornamented with figures or busts as in preceding centuries.

As iron became plenty the production of table knives and forks was greatly cheapened. The blades and tines were also of finer steel, and, for all ordinary purposes, assumed a standard shape. The handles continued to be made of wood, bone, ivory or silver, to which has been added the materials rubber, celluloid and pearl. Forks and spoons are still produced in silver, though rarely if ever inlaid with precious stones, as in the Mediæval Ages. At the present day these objects are so universally used that great risk would attend the

employment of such valuable ornamentation in articles daily and unguardedly displayed upon our tables. With a view to still further reduce these risks of robbery, as well as to supply the masses with table ware having the same characteristic elegance of solid silver, the present century has, in a great measure, substituted knives, forks and spoons plated with silver by the electro process. Indeed, so far has this art of electro-plating progressed, that the finest and most beautiful designs are thus cheaply produced, while their durability has been, at the same time, greatly enhanced by a device of triply plating those sections most exposed to attrition, figure 39. The fork has acquired an importance equal to the knife, and can be, if desired, supplied with a cutting tine for dividing pastry and other food easily separated, figure 40. The spoons also are not only made in different sizes, but exhibit a bewildering diversity of rich and delicate patterns. Numerous combinations of the knife and fork, adapted to special purposes, have been devised by American ingenuity. For instance, we have them constructed in the form of a pocket knife, with the handle of the fork, when closed, sliding into the handle of the knife, figure 41. This is especially valuable to the hunter, soldier, mining prospector or other person whose vocation demands little baggage closely packed.



FIG. 39.

A knife-fork, for one-armed men, figure 42, is also a unique specimen of adaptability to special demands; the food being cut with a rocking motion of the blade and conveyed to the mouth by means of the three tines or points at the end.

A knife-fork, for one-armed men, figure 42, is also a unique specimen of adaptability to special demands;



FIG. 40.

the food being cut with a rocking motion of the blade and conveyed to the mouth by means of the three tines or points at the end.



FIG. 41.

The knife, fork and spoon have become such indispensable articles of table service, and so universally used among civilized nations,

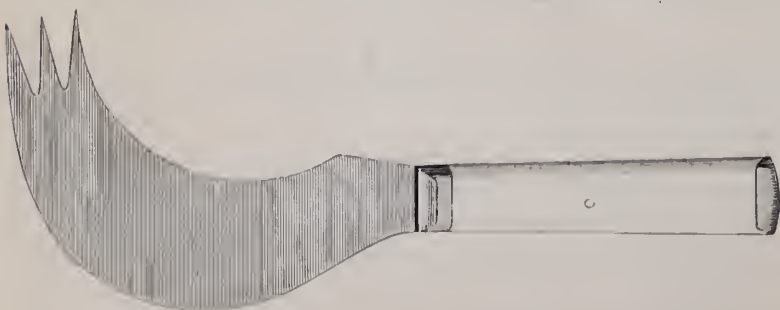

FIG. 42.

that any mention of the different styles seems superfluous. If all men are not "born with a silver spoon in their mouth" they are cer-

tainly taught how to use one at an early age, and though "fingers were made before forks," the digits of the present generation surely cannot claim priority of manufacture. Whether or no in the coming centuries any great changes will be made in the customs and utensils of the modern table remains to be seen, but it does not seem that any objects could so fully answer the requirements for which they are intended as those in use at the present day.

[THE END].

(Copyright Secured.)

The Musical Box—And How to Repair It.

[BY C. H. JACOT.]

THERE IS hardly a watchmaker at the present time who is not called upon, occasionally, to repair a musical box, and there are so many of these instruments in a large city, that a competent workman, who is able to repair them properly, will find his skill well remunerated, many of them being quite valuable and belonging to persons who are able and willing to pay liberal prices for good work. Yet there are comparatively very few workmen, even among the best watchmakers, who can make these repairs in a creditable manner. We have seen many a musical box thrown aside as worthless that could have been put in order at very little time and expense if it were intrusted to one acquainted with this branch of work, while it often requires much time of one who is not acquainted with the theory of their construction, no matter how skillful he may be in other branches.

The reason is that while the mechanism is very similar to that of a clock, the musical part requires special knowledge, which can be obtained only in the factories where they are manufactured, or from workmen who have been engaged in them, and fully understand all the details and processes of manufacture. In the following article we give a few hints for the purpose of aiding the repairer in his perplexities, confining our instructions to the principal difficulties likely to be encountered by him in his repairs of musical boxes, taking for granted that he be a watchmaker. We would advise him, however, to send all musical boxes with ailments graver than those explained below, to some specialist, to be found in all larger cities.

In order that our instructions may cover every disorder likely to be found in a musical box, we will suppose one that requires a thorough overhauling, and proceed in regular order, as we have practised it for many years; so that when a musical box is brought to the watchmaker he will be better able to see what is to be done and the best means to adopt, no matter what the difficulty may be.

EXAMINING THE BOX.

Before the repairer attempts anything let him examine, first, whether the cylinder is in good order; that is, if the pins are straight. If they are bent in all directions, with a large number of them broken, the box has "run."

We call "running" when, by accident, the box has run down without the fly-wheel (which regulates the speed of the cylinder). Hundreds of boxes have been ruined in one minute by accidentally or ignorantly removing the fly-wheel when the spring was wound; this will cause the pins (and often the teeth of the comb), to break or bend backward. To prevent this accident, the greatest care must be taken to ascertain that the mainspring is entirely down before the fly wheel is removed or any part of the mechanism; for should the cylinder "run" even a quarter of a revolution without the fly-wheel, it would cause great damage by spoiling the hair springs, and bending the pins out of their proper places.

Before winding the box ascertain that all the screws are tight in place, as it sometimes happens that a box has previously been taken apart by incompetent persons, and put together carelessly. In this case it might "run" in your hands and be ruined unless this precaution is taken.

If it has "run" on only one tune, the tune will have to be suppressed, as will be explained further on. If it has "run" on all the tunes, it is probably not worth repairing, and it would not be advisable to try it, as it will never give satisfaction either to you or your customers.

If the box will run, listen how it plays; if it has a dull sound, strike a few light blows on different parts of the cylinder (where there are no pins), and if it sounds hollow, the cement, of which it is one-half full, does not adhere to the metal (the box having been exposed to an undue degree of heat). Sometimes it has melted so much that the cylinder can not move on its shaft; most frequently the cement has melted only on one side, or on one end of the cylinder; this can be easily ascertained. The proper way to remedy this defect is by re-cementing, which will be explained further on.

TAKING THE WORK APART.



Fig. 1.

The next thing to be done is to take the movement out of the box, by removing the four screws on the outside (mark these so as to return them to their proper places); then place the movement on the bench, taking care that no tools lie under it to bend the pins of the cylinder.

Now remove the comb (the box having stopped at the end of a tune, so as to have no pins in contact with the comb), unscrewing it with a good large screw-driver. In fig. 1 we give the shape of one we use, which has no chance of slipping and breaking the comb. It is made from an old file.

BROKEN COMB—HOW TO REPLACE THE TEETH.

If one or more teeth are broken, they can be replaced and be as good as new if it is done properly. But if several are broken side by side, it is sometimes very difficult to tune them accurately, as it often occurs that the scale is not marked under the comb, and we may not know how many notes are to be tuned on the same pitch, since the teeth of a musical box are not tuned in regular succession like a piano or organ. In such a case the tone is to be guessed, and your success will greatly depend on your musical talent.

HOW TO REPLACE A POINT.

If only the point of a tooth is broken, it is not necessary to replace the whole tooth, but only its point, as shown in fig. 2; raise the

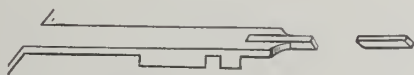

Fig. 2.

broken tooth by introducing a wire under it, and resting it on the others; then, with a blowpipe, take the temper out of the end of the tooth, just enough that you can make a small notch with a narrow file; next fit into it a piece of tempered steel, and solder it in place with a small soldering iron; the point must then be finished in the manner explained further on. If the tooth is loaded with lead at the end, care must be taken not to unsolder it.

HOW TO REPLACE A TOOTH.

If only one tooth is broken, take a piece of steel and make one of the same shape as the broken or adjacent ones, with the point a little longer and wider; but a heel must be made as indicated in fig. 3.

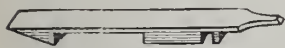

Fig. 3.

Then temper the new tooth, drawing it to a dark blue, in order that it may vibrate and at the same time be filed, and scrape clean its heel, so that the solder may flow. In the steel block of

the comb make a notch with a file of the same width as the tooth, as shown in fig. 4. Put it in place firmly enough to remain in position while it is being soldered. Then take a heavy soldering iron, such as is used by tanners, and solder it with soft solder and soldering fluid, care being taken that the solder runs all around it. Wash the

comb in water, next in alcohol, to remove all traces of acid, and

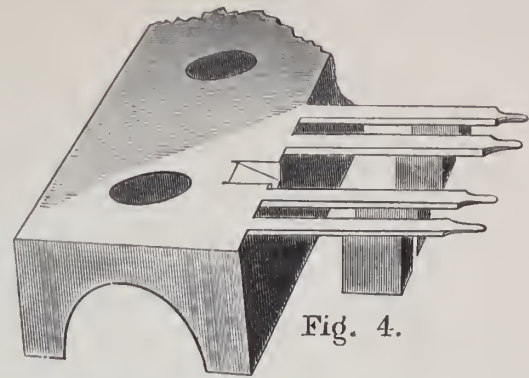

Fig. 4.

scrape off all superfluous solder. If the job was done properly the new tooth will sound as well as the others, and hardly show the mending.

In scraping, as well as in tuning, great care must be exercised not to file the other teeth, for very little filing, or even rubbing with emery paper, will lower the pitch, and, consequently, put them out of tune.

N. B.—When several teeth are broken side by side it will be necessary to procure from a material dealer a piece made in the factory for that purpose, with the same number of teeth in it and of the same division and shape.

The tooth must then be finished and tuned by filing underneath. Finish the point of the tooth by filing it to its proper width to correspond with the other points, and at the same time to bring it exactly midway between the two adjacent points. For making the point of the exact length hold the comb perpendicularly, with the teeth resting on a piece of plate glass. This will readily show how much the point is to be reduced in order to bring it to the proper length. Be very careful not to make it too short.

Now bring the point of the tooth as nearly as possible to the same level. If it has to be lowered, or moved to the right or left, it can be done in the following manner:

To shift it to the right or left, place the tooth so that it will rest evenly on a flat and tempered anvil (see fig. 5), and strike on the left to move it to the right, with the sharp end of the hammer (two or three strokes will suffice), and *vice versa*; the tooth must be struck on the under side. To raise or lower a tooth, the anvil must be tempered and cut like the edge of a file (see fig. 6); hold the tooth evenly on the anvil, strike a few blows with a small, flat, soft hammer, and the tooth will bend upward. Great care must be taken when doing this, since a tooth is easily



Fig. 5.

broken with the hammer.

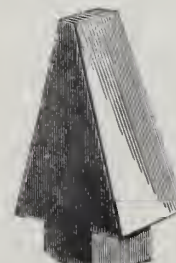

Fig. 6.

The comb now being repaired, replace it on the bed plate, and the line of dots made on every cylinder will enable you to see whether the new points are in their proper positions. To be fully convinced make the box play a few tunes, and if the pins pass in the center of the points, they are true, if not, correct as directed above.

TUNING NEW TEETH.

The next thing to be done is to tune the new tooth or teeth. Take a piece of brass a little thicker than the width of the tooth, fasten it in the vise, and make a notch lengthwise on the edge as long as the tooth; then rest the tooth in it with the under side up, and press the comb down, so as to make the tooth rise enough to be filed without danger of filing the others.

Use a square file, made for that purpose, about a quarter of an inch wide and six inches long, and sold by material dealers. File the tooth near the point to raise the pitch, and near the comb to

lower it. With regard to the teeth loaded with lead it is only necessary to add to or cut some of it.

If the tooth needs a hair spring put it on before tuning, or the weight of the pin will alter the pitch.

If no teeth are broken, see if any of the points are worn; if so, take an oil stone as long as possible and perfectly flat, and pass it two or three times over all the points, then examine whether they have all been touched, and repeat the operation, if necessary. A piece of plate glass with powdered oil stone will be still better.

HAIR SPRINGS.

We now come to the part most troublesome for watchmakers; that is repairing the hair springs, and on this account we shall enter into some details. As they are of the first importance to insure the proper performance of the box, and are easily damaged, the repairer must understand their use thoroughly, and how to shape them, otherwise the box will give certain disagreeable, whistling sounds, which greatly impair the effect of the music.

This whistling sound is produced by the sudden stopping of the vibrations of the steel tooth, caused by several pins coming in close succession under the same tooth; and the object of the hair spring is to stop these vibrations gradually, before the point of the tooth rests on the pin. Consequently, the hair spring must be stiffer to stop the vibrations of the lower notes (being loaded with lead) than for the higher; but in repairing it is easy to find the proper strength as generally only a few are missing, and it can be ascertained from the one next to it. The steel for hair springs is sold by the foot, and numbered according to strength from No. 1 to 8.

REPLACING HAIR SPRINGS.

Examine each hair spring, and break off all those that are worn or have a sharp bend (these having been caught between the tooth and pin), then place your comb upside down on a smooth piece of board about the width and length of the comb. Remove the pins which held in place the hair spring with a pair of small flat pliers, or by pushing them out from the back, and lay them on the bench in the same order in which you take them out, so as to know where they belong, for if changed they may alter the pitch of the teeth and make discord. Then take your hair spring steel, introduce it in the hole, push the pin in hard, and cut the steel $\frac{1}{8}$ of an inch longer than the point, and so on for each one. When this is done

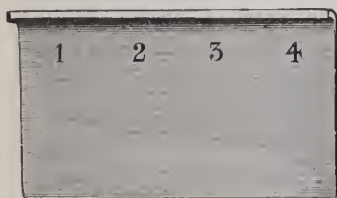

Fig. 7.

resting against the points of the teeth and the straightened hair spring projecting over the edge of the gauge. Move the gauge to either side, until the projection of the hair spring corresponds with the thickness of the gauge, and note the exact place on the gauge. Having thus obtained the measure, cut the other hair springs the same length by resting the cutting pliers against the edge of the gauge. Use a sharp pair of pliers for this operation. It is important to have the hair springs all of the same length, or they will be irregular in shape.



Fig. 8.

To give the shape and curve to the hair spring, we use a pair of tweezers made for that purpose (see cut No. 8). Hold the comb upside down, horizontally, with your left hand, then with the tweezers press the hair spring, and in moving from the pin give it the same curve as those which have not been disturbed. The hair spring must come nearly to the end of the point, but without touching it; the curve should be even and without any sharp bend, so that it will recede before the pin and press upon the point of the tooth, stopping gradually its vibrations, (see fig. 9). Any jeweler or watchmaker having musical boxes

to repair ought to practice this operation until successful, since it is the greatest difficulty in repairing these instruments; moreover, it is well worth acquiring, as a good workman can always command high prices for this kind of work.

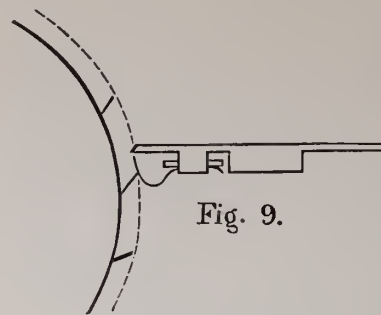

Fig. 9.

as the hair spring for stiffer teeth. They are secured in place by dipping the wide end in a thick solution of shellac and alcohol, resting flat and leaving the end projecting, and when dry (which takes about 12 hours), they are cut even with the points. Care must be taken to select barbs stiff and not wider than the points. The same directions should be followed with regard to small musical boxes, which are provided entirely with these barbs. They are soon worn out, and should be changed each time the box is cleaned.

FLY WHEEL—CAUTIONARY RULE.

Now if the box will run, let it run down entirely, and to be sure of it, lift the click of the barrel bridge. If it will not run let down the main spring as you would that of a clock, by holding the lever and raising the click. We repeat it again here: *Never unscrew the fly wheel or any part of the mechanism without ascertaining if the mainspring is entirely run down*; and, particularly, *when the comb is in place*. When you are thus sure that there is no danger remove the fly wheel, then see if the cap jewel is worn by the point of the fly wheel staff; if so, put in a new one, or if you have none, shift the plate so that it will work on another spot; and be sure to polish the end of the fly wheel staff, or the cap jewel will soon be worn and cause the box to stop or go irregularly. See if the pivot holes, and especially the upper one, are not too large; if so, bush them, or they will cause the fly wheel to rattle when in the box. See that the stop piece on the fly wheel staff is not too loose, nor so stiff as to check the fly wheel too suddenly.

Next see if the small wheel in contact with the fly wheel is in good condition; if the teeth are too much worn or have been injured, get a new one, otherwise you will only lose your time in trying to repair it, and after all will be obliged to change it. In replacing the new wheel rivet it well, so that there will be no danger of its getting loose, for this may cause the ruin of the box. See also that the other wheel is well riveted, then have all parts well cleaned as you would a French clock, put them together, and try if they will turn freely. If not, adjust the depthing of the fly wheel by turning the screw at the back of the bridge. Oil all the pivot holes and the fly wheel staff, where in contact with the wheel.

MAINSRING BARREL.

Next remove the mainspring barrel. See that the click work on the lever and bridge is in good order, and that the hole in the bridge is not too large; make a mark on the barrel arbor, so as to replace the male stop work in the same position. The mainspring must be set on as much as possible, leaving only $\frac{1}{4}$ of a turn over on the end.

If the mainspring is stuck, on account of bad oil, it must be taken out and cleaned. Oil the mainspring before putting it in the barrel; put the arbor, with the barrel containing the mainspring, on a lathe and polish it. Clean and polish all the parts and put them together. Use good clock oil for the spring as well as everywhere. The click screws must be screwed in hard and have a little oil on them, or they will work loose and occasion an accident. The lever must work a little stiff; a piece of sheepskin is to be placed between the lever and washer, to lessen the friction. Have all parts oiled wherever there is any friction, and leave the female stop work to be placed later on, as we shall show.

TO RE-CEMENT THE CYLINDER.

Next in order is the cylinder. If it requires to be re-cemented take it all apart; take off also the star wheel from the cylinder wheel, then oil well the cylinder shaft and pin with common oil, to prevent the cement from adhering to the shaft when melted, and put it on a lathe large enough for that purpose. See that it is well secured but turns freely, with the points oiled. Now take a shallow but wide tin pan, put some alcohol in it and light it, keeping it under the cylinder, revolving the cylinder slowly and moving the pan from right to left, in order to heat it uniformly all over. When you see the cement come out of the pin hole at the right end of the cylinder, remove the pan and make the cylinder to revolve as rapidly as possible until it has somewhat cooled; then a little slower until it has cooled enough to be taken in the hand (for a large cylinder it takes about half an hour to do it). Take it quickly from the lathe, pull out the shaft and remove the cement from around the pin hole while it is soft, and let it cool entirely (half a day at least). The whole operation must be performed very carefully as the least mishap may cause a disaster. If overheated the left end of the cylinder might come out and the cement escape. When perfectly cold it is to be polished, and the only proper way to do this is on a lathe, the same way as for re-cementing. Take some powdered scouring brick or tripoli, with alcohol, and spread it all over the cylinder; then, with a wide, stiff brush pressing on the cylinder, make it revolve very rapidly, and in a few minutes it will be as bright as new. Polish until the alcohol is entirely evaporated and the cylinder perfectly bright and clean. Then take a sheet of thick paper, the width of the cylinder, and wrap around it, so that in handling it the warmth of the hand will not be felt. It is useless to say that in handling the cylinder the greatest care must be taken not to bend or break the pins.

When the box has "run" on one tune only, and all the others are good, the best way is to suppress that tune altogether in the following manner: While that air is playing make a mark on the side of the star wheel where the cylinder stud rests; then take it apart and file it to the height of the preceding tune, which it will repeat. When the damaged tune is either the first or last, you can substitute any of the others instead by filing or soldering a piece of brass of the proper height. See also that the end of the stud is properly rounded and polished, so as to slide easily over the incline of the star wheel.

PUTTING THE WORKS TOGETHER.

When everything is nicely polished and cleaned you may commence to put it together. The cylinder shaft must be well cleaned, and the cement carefully removed from it. Screw on the star wheel with a drop of oil under it, then pass an oiled rag over the polished part of the shaft with just enough of oil to moisten it, but never put any oil there, for in contact with the cement it will thicken so as to prevent its sliding readily. Clean the holes of the cylinder, making sure that no cement is left in or near them. Put it in place with the spira' spring and pinion, the latter with the number on the same side as the one stamped on the shaft; try if the cylinder slides easily on the shaft. Screw on the bridges and see if the shaft is perfectly free without the least end shake, for if there were any it would be impossible to make the box play properly. Should there be, give a light tap with a hammer on the side of one of the bridges, and try again the play. If too stiff strike on the end of the shaft with a piece of brass so as not to injure the point. Now put on the barrel, screw it firmly, see that the clicks work properly, screw on the fly wheel bridge firmly, and wind the spring a little to see if the fly wheel turns freely. Put in place the stop piece of the fly wheel bridge, and see that when the pin falls in the cylinder wheel notch the other end stops the fly wheel instantly.

This done, wind the spring fully, and let it run down enough to place the female stop work in its proper position, so that, in winding, the strain will be on the stop work and not on the main spring. Now put in its place the steel piece that causes the air to change; let the box run and see if the cylinder shifts easily and if the star

wheel has moved just enough to rest the stud on the flat space; if it goes too far it will make the pins catch on the edge of the points of the comb, or sometimes two tunes will play at a time, and make a horrible discord and spoil the hair springs.

TO PUT THE COMB IN PLACE.

We are now ready to put on the comb, which has been previously set in order. If it is rusted scrape off the rust, but not on the teeth, or you would put them out of tune. Clean the upper surface with a little oil and give it the finishing touches by rubbing in the direction of the teeth with the palm of the hand. Next put on the comb (the box being stopped at the end of a tune), and fasten it with only three or four of the screws, as it will probably be necessary to take it off several times. Let it run slowly, and look if the pins pass directly under the center of the points; if not, turn the cylinder stud in or out. If it is of a kind that cannot be turned, shift the comb with a good sized hammer, striking on a large nail or piece of soft iron resting against one of the screw holes. See also that the teeth of the same chord fall at the same instant at both ends of the comb. The end falling late is too near, shift it back.

Now see how the hair springs work. If they have been shaped as directed, they will not require much alteration. If any of the hair springs have not been properly shaped it will be now detected. Remember that they must be as near as possible to the point without touching it. See also that no pins are bent to the right or left, else they will catch the points and make a disagreeable noise; they must be straightened. Do not mind a few broken pins, they will not be noticed; but if bent, and catching the wrong point, they will.

If the pins should pass in the center of the points on all tunes but one, the star wheel has been injured; punch it at the place where the cylinder stud rests to raise the cylinder.

If you have a musical box with two or more combs, care must be taken that all the notes fall at the same instant on all the combs. To ascertain this hold the fly wheel with the finger, and let it play very slowly, and you will be better able to see if they do; but always fix one at a time, never attempt to set both combs at once. In this way it is also much easier to detect any defect, either from hair springs or bent pins. When the combs are in proper position and the hair springs all fixed, put in all the screws and fasten them very firmly, or the box will not sound well. Remember that in musical boxes all screws must be inserted as firmly as possible.

Now put the movement back in the case and the four screws which secure it, without screwing them in entirely; slip in the metal wedges opposite the screws and drive in the screws hard. If any of the wedges are loose put in a thicker one, for the bed plate must press firmly against the box or it will lose some of its tone. See that the start and change pieces are not too loose on the board, then put it in place as well as the one on the left side.

If there is a rattling noise, it is caused by something being loose about the box, lock, hinges, etc. The lock should be pretty well clogged with wax or grease, else it will rattle.

If the musical box has bells, see that the hammers do neither stand too near nor too far.

Now take a piece of wide broken mainspring about ten inches long, and oil it well on the convex side. Then, while the box is playing, pass it over the steel pins of the cylinder, in order to prevent wear and a screeching noise. Care should be taken, however, that the oil does not spread over the surface of the cylinder.

RECAPITULATION.

For better understanding let us recapitulate the order in which the work is to be done:

1. Examine the box to see whether it be in good condition, and that it has not "run."
2. See if the cylinder needs re-cementing; this is frequently necessary in this climate.
3. Repair the comb, in case any teeth are broken.
4. Fix in the hair springs.

5. Repair mechanism, from fly wheel to barrel, and clean it.

6. Put together in the following order: Cylinder, mainspring, barrel, fly wheel, finally the comb.

There is a great variety in the sizes and styles of musical boxes, but the above instructions will apply to nearly all of them, and will enable any intelligent watchmaker to repair them satisfactorily.

The Cup—Its Art and Customs.

[BY JOHN W. MILES.]

WITH ALL our boasted civilization we are compelled to admit that little, if any, progress has been made in the artistic construction of articles in the noble metals since the renaissance. Our art, like our language, is but a blending or combination of what has been bequeathed us from past ages, and bears little evidence of a separate and distinct departure that would characterize American design as solely of American inspiration. We speak of certain works as Egyptian, Grecian, Mediæval, etc., but of none as American, or if efforts are made to nationalize our productions, by utilizing the Indian, buffalo, or other peculiarity of the country, they are rendered more as auxiliaries to the art sentiments of previous centuries than as a positive departure from conventional rules. With unwavering faith in American genius, and with strong hope that the recent universal interest in decorative art may stimulate sufficient originality to establish a distinctively American school, the writer ventures to recall in popular form some of the successive steps in design that have attended for ages an article in such common use as the cup. Mythological, allegorical, religious and social sentiments have surrounded this article with more numerous and interesting traditions than perhaps any other single product of the goldsmith, while its art has ever been a true exponent of the prevailing taste. The manufacture of gold and silver into articles of use or ornament has been classed during late years more among the industrial than among the fine arts, and yet, in many respects, it is closely allied to painting and sculpture, and fully as capable, in some things, of art expression. What then is fine art? The answer to this question is usually hidden under such a mass of metaphysical verbiage as to be nearly unintelligible and wholly uninteresting to the general reader. Simply explained art is an *ideal*. Nature, therefore, is not art, for nature is *real*, but it is the incentive and source from which true art springs. This distinction divides the work of genius from a photograph. The latter is an absolute copy, but the former is not, as it has been idealized and perfected. A design should possess, therefore, an idea or ideas displaying the mental or moral power of the artist in order to be considered a work of art. At a lecture we *hear* the thoughts of the speaker, from a good book we *read* the thoughts of the author, and in a work of art we *see* the thoughts of the artist. Having thus defined art itself, the inquiry naturally follows, what influences are required for its development? which brings us immediately to our subject. Using the genealogical form we may briefly state that civilization begets culture and refinement, culture begets popular taste and appreciation, and taste begets art. Hence, in every country of prominence in the world's history, art, coeval with civilization, has had its rise, its rule and its decay; the difference between the epochs being merely a difference in taste, influenced more or less by the prevailing estimation, climate, custom and religion of the people. This will be more clearly illustrated as we proceed.

Of the civilization of the Hindus we know little beyond the fact that it was the beginning and foundation of culture, and attained a high stage of development. The late careful study of the classical Sanscrit may, at an early day, remove much of the present uncertainty regarding this ancient people, but we do know, at least, that this great Aryan race, from which we sprang, was also the mother of the early Egyptians. Our knowledge of the latter is of a comparatively extensive character, but it does not extend to an age sufficiently

remote to measure the influence of India and Indian art. We are compelled, therefore, to accept Egypt as the starting point, basing our judgments upon the drawings and hieroglyphic writings that have been preserved, without further seeking for primal sources.

No race or nation has ever acquired distinction without the basis of an elaborate religion; a religion that sometimes liberates and sometimes enslaves the people, but in either case exercising a ruling influence over every event of human life, and furnishing inspiration for the most beautiful and valuable works of genius. In fact the most exalted art that has been given to the world has been devoted to the service of religion, but while the great systems of polytheistic worship, such as the Egyptians, Greeks, etc., have developed an art pre-eminently sensuous, other creeds, such as the ancient Persian fire-worshippers or the Mohammedans, who interdicted all representations of animal form, have required a narrow range. We find, therefore, Egyptian art permeated through and through with the predominating influence of the sacerdotal order, but by reason of the diversity and number of their symbols this fidelity to accepted beliefs and impressions developed a style in no sense tame or unmeaning. In life the Egyptian was surrounded with numerous objects in the animate world that symbolized the gods and mysteries of a ceremonious and complicated polytheism, and even in death the embalmers were held sacred, were intimate associates of the priests and a portion of that religion that overshadowed and penetrated both the cradle and the grave.

In Egyptian art there was a deep underlying principle that ruled the production of all works—the principle of solidity and repose. The thoughts expressed in their art were those of sublimity, but a sublimity at rest; their impressions of nature were massive and grand, but a grandeur of inactivity. They were not allowed to change the conventional designs of the human figure or of any subject connected with religion. The rules pertaining to the latter were particularly inflexible, and established habits confining and restricting the genius of the Egyptian artists even in objects of luxury where great latitude was permissible. Their designs, drawn from favorite objects, such as the lotus and other flowers, and various animals and heads of animals, were exact or nearly exact representations of the original. There is no evidence that they studied the sentiments of these objects, and we find few harmonious combinations woven out of these sentiments. This would indicate a deficiency in both talent and taste, though they evinced considerable taste in color and occasionally in form. Their knowledge of proportion, exhibited in their gigantic monuments, was very extensive, but they had little idea of the beautiful, and hence their work, though remarkable, does not betray that subtle power that we call sentiment in works of art. The religion that made sacred certain beasts, birds, fishes, insects and flowers also caused these symbols of faith to be represented in both the greater and lesser objects of use or ornament. Among these emblems appear most frequently the lotus flower, which was connected with Harpocrates, or Horus, the son of Isis. Representations of it appear singly or in combinations as an embellishment upon a large proportion of objects, and it is often seen carried in the hand, especially upon festive occasions. From the numerous instances in which it occurs it is possible that it had significations of which we know nothing. It was in some form attached to the rites of hospitality, and while guests were adorned with wreaths and garlands the lotus alone crowned the head and hung over the brows. As Horus was the god of silence, this custom may have signified that whatever occurred at the feast or under the influence of the wine should be kept secret. Under these circumstances it is not surprising that the cup should sometimes represent this emblem, not only in shape but also in decoration; the graceful lines of the flower forming the cup itself while the petals or corolla were delineated upon the external surface, figure 1. In so far as this was an accurate copy of nature it was symmetrical and pure. Nature avoids as far as possible the circle or segments of a circle, preferring the more graceful ovoid forms. Hence, by following nature, the artist has provided outlines for the cup that are seg-

ments of the oval, while conventional law has decreed for the petals a stiff angularity of outline, not only untrue to nature but also untrue to the beautiful in art. That the superior beauty of the oval was

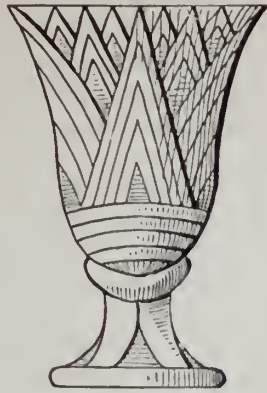

Egyptian Cup, Figure 1.

recognized by them is evidenced by the numerous vases which have this form, but these are often ruined artistically by ornamentation hampered with the restrictions of their religious laws. Saucers were also used as a cup for drinking and were often finished with symbolic figures. The one of blue pottery, represented in figure 2, bears both the lotus and the fish, but though the combination displays some ingenuity the treatment is habitual.

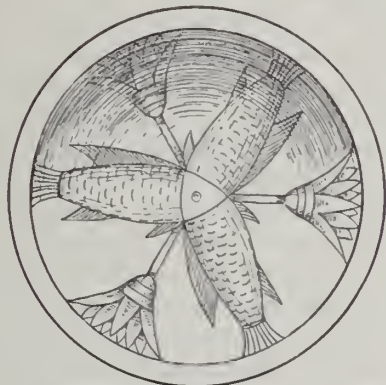
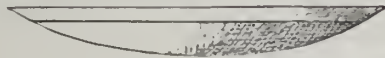

Blue Pottery Egyptian Saucer, Figure 2.

The cups of the Egyptians were varied in both material and form, as they well might be, there being no laws of restriction regarding them. Some were plain without ornament; some were painted, which, according to Pliny, was a style of decoration for silver preferred to chasing; others were modeled after the larger vases, and others still had handles, but though many embodied some form of symbolism they were equally destitute of sentiment. The principal value of Egyptian art, therefore, is its extreme antiquity and its effects upon other nations less advanced, for even the Assyrian adopted the winged globe, and, in the earlier Greek art, traces can be found of Egyptian influence. While we may admire the majestic grandeur of Egyptian architecture, constructed with such wonderful knowledge of proportion, we must also admit that among all the monuments, relics and illustrations that have been discovered there is an entire lack of anything which we would call the beautiful in art.

Among the Egyptians, as also the Assyrians and later nations, the most prominent personages had servants especially designated as cup bearers, and the office was by no means considered menial, as it was often filled by persons of high rank and noble blood. The cups themselves were very highly prized, as well probably from associations connected with them as the valuable material of which they were often composed. It is hardly necessary to refer to Joseph's cup that was concealed in the bag of his brother Benjamin further than as an example of the high value set upon these articles, particularly if they

were preferred favorites and in habitual use. There was no particular restriction regarding the use of wine by either sex, and its consumption was very great. It was often taken in excess, and as their artists possessed a strong predilection for the grotesque we find representations of intoxicated people, both male and female, in their paintings. In one the guest is carried home on the shoulders of his servants, and in another the lady is seeking to be relieved of the surplus wine by a process well known at sea. The primal courtesies shown to guests at dinner were: decorating the person with garlands, anointing the head with ointment and the presentation of a lotus flower to hold in the hand. Immediately following these wine was offered by the servants. The acceptance of wine was not compulsory and it could be declined without discourtesy. To the ladies it was brought in a small vase, from which it was poured into the drinking cup, figure 3, but to the men it was served in a one-handed goblet

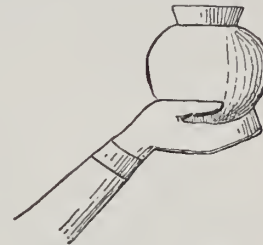

Egyptian Cup, Figure 3.

or in a vase of gold, silver or other material. Some of these golden vases were highly elaborate, having stands and with stems covered with imbricated plates of metal, figure 4. Wine was taken during

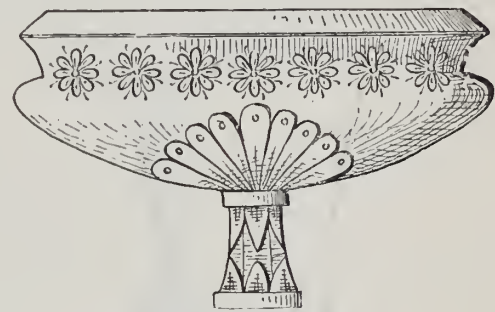

Egyptian Cup, Figure 4.

the meal, and perhaps also toasts were given to the health of one another or of an absent friend. Napkins for wiping the mouth were presented immediately after drinking.

The wealth of the eastern nations in gold and silver, especially Assyria, was something fabulous. According to Zerxes the gold obtained from the temple of Belus alone amounted to 7,350 Attic talents (about \$7,000,000), and we are told by Athenæus that the funeral pile of Sardanapalus supported 150 beds of gold, on which his concubines reposed to share his death, with 150 tables also of gold, 10,000,000 talents of gold and 100,000,000 of silver, besides costly robes, garments, etc. There is something mythical in all this, but the Assyrians undoubtedly were possessed of immense stores of the precious metals, which, in the absence of coinage, were worked into useful forms for greater convenience of preservation. Pliny speaks of a bowl weighing fifteen talents. This was called the drinking bowl of Semiramis, but probably in the same sense in which we call the obelisk in Central Park "Cleopatra's Needle," since such an enormous piece of plate could not possibly be used for the purpose designated. The art of working metals attained great excellence in the east. Dr. Birch remarks that "the art of toreutic work in Asia influenced so largely even the Greek world at a later period as to rival and gradually supersede the fictile painted vases of the Greeks." The drinking vases were frequently wrought in the shape of the head and neck of an animal, such as a lion or a bull, but that there was great diversity of shapes we may learn from the biblical book of Esther, wherein is described the splendor of the festivals given by the Babylonian king. The princes and nobles of his vast kingdom were, on one occasion, feasted for one hundred and eighty days, and the incident was supplemented with an additional feast of seven days to all the people of

Shushan assembled in the gardens of his palace, and when the royal wine was served without stint in vessels of gold each one differing from the other. The embossed work of the Assyrians was the most artistic, being executed with great taste and skill. Upon the bowls and dishes were represented hunting scenes, combats between griffins and lions or between men and lions; sometimes landscapes with trees and figures of animals, sometimes mere rows of animals following one another. They usually contained a star or scarab in the center, beyond which was a series of bands or borders patterned most commonly with figures. They were all semi-Egyptian in character. The Sidonians were the most renowned workers in metal of the ancient world, and, occupying a position between Egypt and Assyria, may have served as a channel for the influence of Egyptian art.

The Assyrians drank wine very freely, the country being emphatically "a land of corn and wine." The cup bearers were among the principal officers of the court and very important personages, being usually of noble blood. Great banquets, in which drinking was practiced on a large scale, seem to have been frequent. In the banquet scenes of the sculptures it is drinking and not eating that is represented. Attendants dip the wine cups into a huge bowl or vase, which stands on the ground and reaches as high as a man's chest, and carry them full of liquor to the guests, who straightway fall to a carouse. According to the sculptures the arrangements of the banquets are curious. The guests, in one instance (Khorsabad), forty or fifty in number, are divided into messes of four, two on each side facing each other, each mess having its own table and attendant. Every guest holds in his right hand a wine cup, the lower part modeled in the form of a lion's head, from which the cup itself curves outward, figure 5. They all raise their cups to a level with their

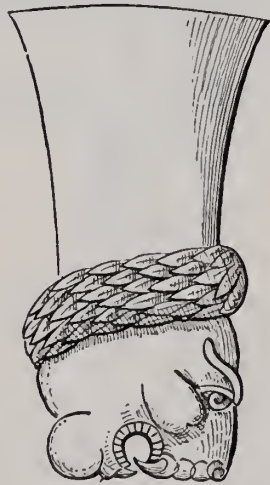

Assyrian Cup, Figure 5.

heads as if pledging each other or drinking a general toast. From a slab recovered from the ruins of a palace that belonged to Asshur-bani-pal we have a representation of the king and queen drinking from a shallow cup or saucer supported on the thumb and fingers of the right hand, figure 6.



Assyrian Cup, Figure 6.

The wealthy Babylonians were fond of immoderate drinking. The luxurious viands that loaded their tables were served with the finest

of imported wines in goblets of gold and silver. Like the Egyptians, music was given at the feasts. We are told that at a banquet given by Annarus the perfume laden air was filled with the music of 150 female performers while the guests quaffed their wine. Nor was this all, for, according to Quintus Curtius, not only were women hired for this purpose, but the wives and daughters of the nobility, as the wine went round, lost all restraint, and, rising, danced before the men, divesting themselves of one garment after another till entirely nude, when were enacted scenes of glaring immodesty. And these were the ladies of the best families. These diversions appear to have been a requisite of all feasts, but the splendid dresses of the guests, the rich carpets and hangings, the delicate and costly plate and numerous attendants gave an air of grandeur to the entertainment that, if deeply sensuous, was nevertheless truly magnificent.

The Persians claim to be the originators of wine making, and they have a tradition of its accidental discovery by the king Jemsheed, which runs as follows: The monarch being very fond of grapes stored a quantity of them in his cellar. Some time afterwards the vessel which contained them was opened and the grapes were found to be in a state of fermentation, and, being very acid, were believed to be poisonous, and marked accordingly. A lady of his harem having suffered greatly from sick headache determined upon suicide, for which purpose she drank some of the grape juice and naturally became intoxicated. After sleeping a considerable time she awoke perfectly well, and was so pleased with the result that she managed in time to finish all the poison. The king becoming acquainted with the facts used the knowledge to his own advantage. The story is no less plausible than many similar ones accepted as true, but history does not record any great amount of dissipation among the Persians before success in arms placed them in the front rank of nations. With that fatal facility, which seems to belong to all races, of adopting the vices of conquered enemies, the victorious Persians abandoned their early habits of frugality and sobriety when the conquests of Darius flooded their cities with the spoils and customs of Babylonia and adjacent countries. The wealthy took pride in the number and value of their gold and silver plate, of which drinking cups formed the greater share. Still clinging to the custom of but one meal a day, they began early and made it last until night, and it was a matter of emulation between them which could drink the most wine in the time. Drunkenness was, therefore, common, and once a year, at the feast of Mithras, the king himself was in duty bound to get drunk. All important affairs were deliberated upon when they were intoxicated, and whatever determination may have been reached was afterwards confirmed or rejected when sober. This custom was also reversed, and the resolves of sober debate were reconsidered and acted upon when drunk. With such habits, which appear to have been universal, it is not surprising that the drinking utensils should be not only numerous but also of the most precious materials. Herodotus tells us that after the battle of Plataea the Greeks found the tents of the conquered Persians "decked with gold and silver, and couches gilt and plated, and golden bowls and cups and other drinking vessels." Vast quantities of these and other articles made of the noble metals were included in the spoils, and long after the battle the Plataeans continued to find "chests of gold and silver and other precious things." If such valuable utensils formed part of their camp equipage what splendor must have ruled in their palaces and homes?

(To be Continued.)

Depthings.

[By J. RAMBAL, teacher of Horological School of Geneva, in *Allg. Journ. d. Uhrm.*]

Continued from page 228.

II.—PRACTICAL PART.

CONTENTS:—10. Recapitulation of the fundamental principles to be observed in the construction of depthings. 11. Necessity for retaining the curvature of the tooth at its greatest dimensions; opinions of Preud'homme and Jürgensen

concerning this point. 12. Incompatibility of the driving before the lines of centers; a remedy proposed by Camus for correcting these defects. 13. Disadvantages of Camus's system; the same ends are obtained by a change of the tooth curve. 14. The transmission of power in the different positions of the driving.

10. Before we continue our studies, let us recapitulate the fundamental principles of the construction of a depthing, as they can be summed up from the preceding article. The following points were established:

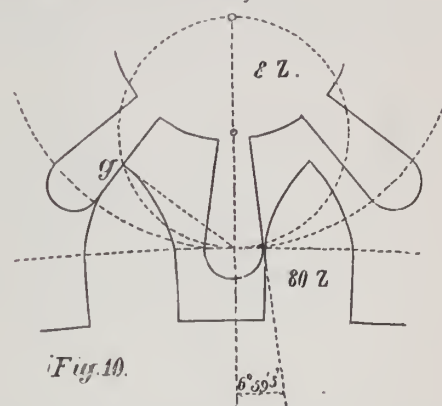
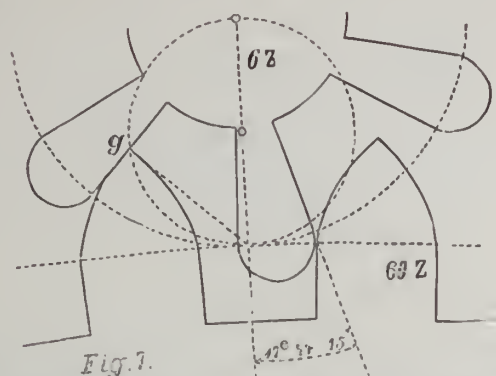

Figs. 7 to 10 —The teeth have the epicycloidal curves, tooth and space are alike.

1. The pitch circles of wheel and pinion must, among themselves, stand in *exactly* the same ratio as the number of wheel teeth to that of the pinion leaves.

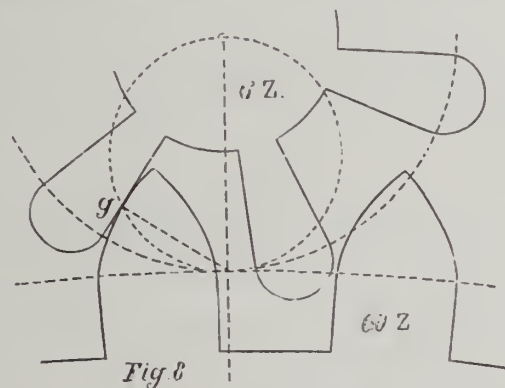

2. The curvature of the wheel tooth and the flank of the pinion leaf are formed by two lines, which have been produced in common by the same point of a generating circle.

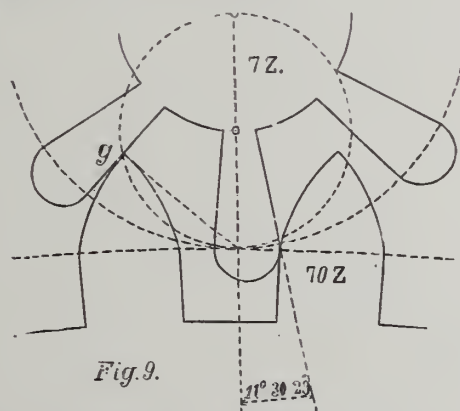

3. In order that the leaf-flank form one straight line leading to the center of the pinion, it is necessary that the generating circle be the one-half of the pitch circle of the pinion.

4. The thickness of the pinion-leaf is generally established at the one-third of the division.

5. The dimension of the tooth must be thus that it permits sufficient shake to the depthing.

11. The necessity to retain the epicycloidal curve at the fullest possible dimension will be easily recognized from this construction of the depthing, if the driving before the line of centers is to be reduced to the smallest possible quantity, which is obtained by leaving the tooth as long as possible. Even the old watchmakers recognized the great importance of this axiom; Louis-Baptiste Preud-

'homme, more than a hundred years ago (Geneva, 1778), wrote the following:

"Toothings which work upon many leaved pinions, for instance, 12 leaves, must possess as much space as tooth, and in the proportion that pinions and wheels decrease in their number of leaves and teeth, the fullness of the tothing must be increased correspondingly, so that the tooth remain large enough to possess a sufficient surface that the curve receive the necessary dimensions."

Jürgensen says the same: "The teeth of wheels which seize into pinions of a small number of leaves, must be wider than those seizing into pinions of many leaves."

It is true that a great many modern authors lay down an equal division of tooth and space, without being, as we think, justified in sacrificing so important a property of the tooth, although this equality of tooth and space offers a greater facility in the trigonometric calculation of the height of the addenda. Happily these doctrines are not always strictly adhered to in the practical execution, and manufacturing watchmakers have generally retained a tooth shape larger in comparison to the space; this is my experience, at least, after measuring a large number of teeth of different watches. The suitable proportions will be given at a future time.

12. We next come to the most important point of the depthings of pinions with a small number of leaves, viz., the driving before the line of centers. If this does not commence at an unduly great distance before said line, it would be no serious defect; but, unhappily, neither the division of the wheels is as exact as it should be, nor are the pinions of a faultless regularity; an increase of the unfavorable conditions, therefore, is produced by these circumstances, which may even go so far as to produce a butting and the standing still of the watch.

This disagreeable possibility occurred oftener in former times, when the tothing, made by hand, was far more irregular in its shape. We append a remedy, recommended by an author of the last century, to ease this defect:

"Since it is almost impossible to produce the tothing with that regularity and precision which is necessary to enable the pitch circumferences of wheel and pinion to always revolve with the same velocity, and since the inequality and other defects of the tothing are the causes that a few wheel teeth do not drive the pinion leaves so far behind the line of centers as they should, whereby butting is likely to be produced, watchmakers have sought to forestall these insufficiencies by making the pitch diameter of the driving part a little larger than it should be in ratio to the part driven.

"By means of this increase of the wheel diameter, which is to be chosen in accordance with the defect to be feared, the tooth following the one which drives the pinion leaf behind the line of centers, will seize the next following tooth a little later, and when the preceding tooth has then driven the pinion so far behind the line of centers as it should, the wheel will assume a trifling accelerated motion, which, however, it does not transmit upon the pinion, which is a defect in itself; but this defect, which has been purposely created, is less to be feared than the shortcomings that might be anticipated if it were sought to prevent aforesaid evil."

13. The above specified remedy, which consists in enlarging the

pitch circle of the pinion by a trifle, stands in contradiction to the principle which we have stated, according to which the pitch measurements of the two parts are to be taken strictly in proportion to their number of teeth and leaves. But if the advice of Camus is followed, a secure principle is abandoned for a speculative one. A calculation of the full dimensions of the parts is then only approximately possible.

The error pointed out by Camus, however, exists in reality. Let us, for this purpose, examine figs. 7 to 10, in which the teeth are

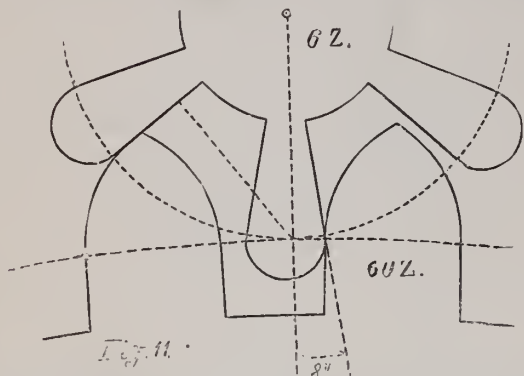

Figs. 11 to 14.—The teeth have the altered curve, the fullness of the tooth is larger than the space.

represented in epicycloidal form, and tooth and space are assumed as of equal dimensions. A single glance at fig. 7 tells us that a depthing in which the driving begins before the line of centers is of the most unfavorable kind, because only a trifling quantity is necessary to produce butting. Because leaf and tooth follow each other in a very small interval before the moment of commencing the driving (fig. 7), so that the least irregularity in the division of the wheel or in the shape of the tooth can lead to a contact of the two parts before the desired time. We propose the following remedies to prevent this error:

1. To give to the tooth the greatest possible breadth, after having paid due attention to the shake of the depthing.
2. To replace the epicycloidal curve by a similar one, by means of

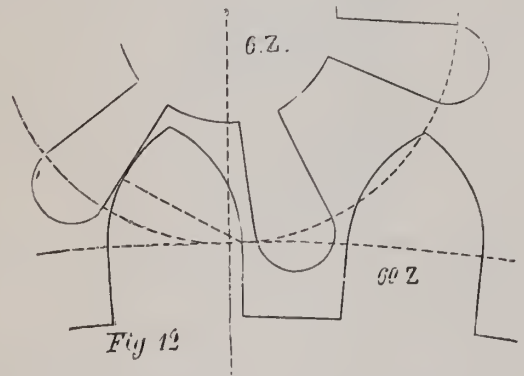

which the driving before the line of centers is reduced to a moderate quantity (fig. 11), and one which at the same time offers sufficient guarantee for the entrance (fig. 12).

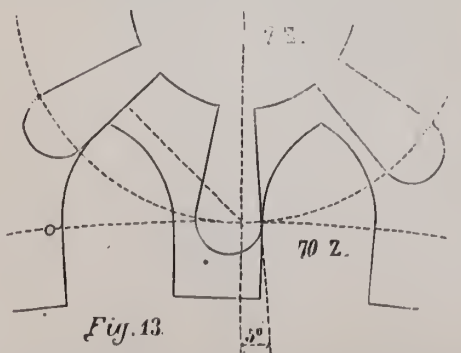

This curve consists of one part of a circle, for which, with a pinion of six leaves, the center is the same as for the tooth addendum. The fullness of the toothing, therefore, amounts to 0.573 of the division.

Fig. 11 shows how, with teeth of this shape, the driving begins at a distance before the line of centers, which is a trifle smaller than the one-half of the pinion thickness (8° , while the pinion thickness amounts to 20°).

On the other hand, the stronger arched curve of this tooth offers

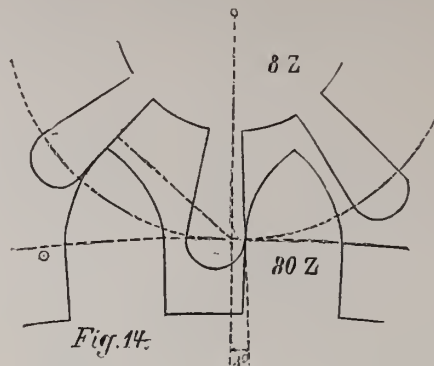

the advantage of a greater security of the entrance, as can be seen from fig. 12.

Figs. 13 and 14 show the same proportions transmitted to wheels, which drive pinions of 7 as well as of 8 leaves. The fullness of the tooth is for a 7-leaved pinion 0.564, and for an 8-leaved one 0.549 of the division. The commencement of the driving, which otherwise would amount to about $11\frac{1}{2}^\circ$ and 7° , is reduced to 5° and 3° .

14. It will be rejoined, however, that all this would be very well, if a valuable property of the epicycloidal curve, to wit, the equable driving, were not sacrificed at the same time by these changes. This new depthing would, therefore, have its periods of varying velocities, in consequence of which an unequal transmission of power takes place.

This objection is really well founded, but we have not undertaken to recommend a faultless depthing, since such a one, with a pinion with a small number of leaves, could only be obtained by means of an epicycloidal curve.

The above paragraph needs an explanation, because many watch-makers are of the opinion that when the driving is a regular one, the transmission of power is also uniform.

When tooth and pinion leaf are in driving upon the line of centers, the lever arm of the power is equal to the pitch circumference of the wheel, and the lever arm of the weight equal to the pitch circumference of the pinion. In the same measure, now, as the tooth drives the leaf, the above-named lever arms also are shortened. When the tooth has arrived at the end of the driving (fig. 7), it will touch the leaf at a point *g*, the length of the lever arm of the weight is then equal to the distance which separates the point *g* from the center of the pinion. The lever arm of the power for this new position can be ascertained by prolonging a vertical line, standing to one side of the leaf, and which passes through the point *g*, as well as through the point of contact of the pitch circle, the interior of the wheel, and drawing upon this prolongation a vertical line from the center of the wheel. The length of this vertical line is then also the length of the lever arm of the power. Geometry teaches that these two lever arms form equal sides of similar triangles, and as such stand in the same proportion to each other as the pitch circumferences, whence follows that the proportion between the lever arm of the power and of the weight is not changed, so that the power at the end of the driving is still transmitted at the same strength as at the time when the points of contact of tooth and leaf were located upon the line of centers.

This conclusion is perfectly correct in a geometric sense, but since we have here to do with movable parts, the matter must also be tested from such a standpoint, because upon the line of centers we have only a simple contact of tooth and pinion, friction is reduced to nothing, and the power is transmitted without loss. During the course of the driving, the tooth slides upon the pinion, this sliding motion attains its height at the end of the driving, and it is, therefore, necessary, in order to find the power, which arrives for transmission at a certain point of the driving,

to deduct from the amount of power of the wheel that part consumed by the friction of the tooth against the leaf.

It will be seen hereby that the power transmitted is greatest upon the line of centers, and that it diminishes during the course of the driving, and is least at the moment when the tooth leaves the pinion.

It is, therefore, erroneous to suppose a uniform transmission of the power in the case of 6-leaved pinions. It is well known that in small watches, for which this class of pinions is used altogether, the balance changes its motion in regular intervals, in spite of all pains taken to overcome this defect in the manufacture of the dephthings.

We therefore believe that the tooth curve formed of a part of a segment, although subject to a somewhat large sliding at the leaf than an epicycloid, is, nevertheless, not any more objectionable than the latter for the transmission of the moving power, while at the same time it possesses the actual merit of offering all the desired security to the activity of the dephthing.

(To be Continued.)

Method of Treating Gold and Silver Sweep in the Assay Office.

A FEW TINY streams of water, trickling monotonously down through a series of cups and funnels, in the dingy cellar of the United States Assay Building in this city, perform an interesting function. Starting from an elevated vat containing two or three barrels of black dirt, the water descends thick and muddy at first into a row of cups. The heavier particles of the dirt settle in the cups, and the lighter particles are overflowed into funnels which empty into another series of cups. The second row of cups retain a certain portion of the dirt and overflow into still another series of funnels, which in their turn supply a third row of cups with their drippings. In this way the trickling goes on until the dirt placed in the vat above has been filtered through eight or ten rows of funnels and washed through half a dozen sunken boxes and vats. This is the process by which the valuable "sweep" of the Assay Department is washed, and it is a process that goes on steadily from day to day, and from year to year. The ordinary waste water of the building is utilized to keep up the constant dripping which partially separates the dross from gold and silver which, in the yearly aggregate, is worth many thousands of dollars. At present a much larger quantity of "sweep" than usual is being washed, in consequence of the strict accounting made necessary by the recent change in the office of "melter and refiner." Mr. Andrew Mason, the present Superintendent of the Assay Office, has been preparing, during the last fortnight, to turn over his accounts as melter and refiner to Mr. Martin, his successor in that department. Every ounce and grain of valuable metal in the melter and refiner's department must be accounted for, including even the invisible particles that are mixed with the dust on the floors, the ashes in the furnaces, and the soot in the chimneys. The clothing of the workmen and some of the implements they use are sometimes burned in order that the gold they contain may be preserved.

The clink of the trowel and the rasp of the chimney scraper have been the principle music heard inside of the melting room since Mr. Martin's appointment. The furnaces have been gutted and the inside row of metal-stained bricks taken out and broken into fine bits. The zigzag flues have been torn down and the blackened bricks thoroughly scraped. Bits of wood saturated with fumes and splatterings of melted gold and silver have been burned in company with old rags, paper caps, metal-stiffened mittens and old shoes, and the carefully garnered ashes mixed with the soot gathered from the chimneys; the broken bricks and bits of old crucibles and ladles have been thrown into the general receptacle for the "sweep." The scrupulous fidelity with which every atom of "sweep" is gathered up was aptly illustrated by the pathetic regret expressed by Levi

Springsteen, the veteran foreman, when told the other night that the big cat had run away with some of the dust in its fur. Before being subjected to the washing and amalgamating process the "sweep" is first passed through a heavy crusher and afterwards through a flour grinding mill. It leaves the mill looking and feeling like fine black sand, in which condition it is turned into the washing vat. The washing apparatus is not only simple in its construction, but it is almost entirely self acting. It was contrived by Mr. Mason with an eye to both effectiveness and economy, and the cost of running it is comparatively trifling. The idea is to wash out of the great bulk of the "sweep" as much of the gold and silver as possible. This is accomplished by means of the series of cups, each series retaining a different grade of dirt. One barrel of pulverized "sweep" will yield about half a bucketful of metallic stuff, which, after being dried, goes back to the furnace and is "fluxed." The substance is remelted in a crucible, each mess being chemically prepared so that the baser metals will be separated from the gold and silver. After extracting the gold and silver the melters again place the combined precious metals over the fire, and with the aid of sulphuric acid separate them. The room in which the separating is done is near the top of the high Assay Building, and while the work is in progress the sulphuric fumes are almost unbearable. Persons unaccustomed to the peculiar atmosphere of this apartment are very glad to retire even before they have familiarized themselves with the manner in which the work is done. If they remain in the room they will speedily be seized with a paroxysm of coughing. It is interesting to note, however, the appearance of the gold just after it has been divorced from the silver. The obliging gentleman who conducted us managed, between coughs, to ejaculate "Indian meal," "gold," "cheese." Two grizzly men were silently stirring a substance that closely resembled wet Indian meal in a huge kettle. This was the granulated gold, and subsequent investigation showed that after being taken out of the kettle it was pressed into the forms of small cheeses, which were left to harden until the refiners were ready to remelt them and run them into bars of rich yellow gold. The silver, after granulation, is treated in the same manner as the gold, and visitors who are permitted to inspect the melter and refiner's department will see countless white cheeses lying about, each one, however, too heavy to be conveniently carried away.

Inquiry as to the value of the precious metals extracted from the half-bucketful of washed out "sweep," elicited the information that the quality of the "sweeps" varied, but generally each mess melted would yield about 100 ounces of gold, silver, copper and lead. Of this quantity 30 or 32 ounces would be mixed silver and gold, perhaps not more than half an ounce being gold. The remainder of the "sweep" is carefully saved, dried, and put into barrels for public sale. Twenty barrels full of the soft, dry dirt usually constitute one lot. Prior to the sale a few ounces are taken from each barrel, thoroughly mixed up and a sample of the mixture is assayed. The lot is then sold to the highest bidder on the basis of the Government assay. The usual assay of the "sweep" sold by the Assay Office in this city shows an actual value of from 11 to 15 cents a pound, and the purchasers pay from 2½ to 5 cents less than the value as indicated by the assay. Superintendent Mason says that the cost to the Government of working over this coarse "sweep" would be greater than the loss in actual value sustained by selling it. The stuff is sold to smelting establishments and to speculators, who sometimes ship it abroad. At the smelting establishments it is made to yield up separately all of its component parts, such as gold, silver, copper, lead, soda-ash, etc. The total sales of "sweep" from the New York Assay Office last year were about 400 barrels, for which \$21,150 was realized. It is thought that the quantity of "sweep" which will be sold in the adjustment of accounts now pending will not be more than 40 barrels.

All kinds of gold and silver coins, plate or bullion of not less than \$100 in value are received at the Assay Office from persons wishing to sell, and it is paid for, after it has been melted and assayed, in coin

or bullion. Some queer articles are passed over the counter in this office. Brokers and pawnbrokers send in large lots of once precious relics, broken, disfigured, and jumbled together like so much old iron. A few days ago a box of gold jewelry was received from a Nassau street jewelry broker. There were two or three pounds of old watch cases, bracelets, lockets, ear rings and rings, all of fine gold and many of them bearing inscriptions such as are marked on wedding and birthday gifts. The whole lot went into the crucible and in a few hours' time a small cake of gold worth about \$250 was all that was left of the collection of relics. "We get a great deal of African jewelry, which is brought home by sailors," said the receiving clerk. "It was only a few days ago that we melted up a lot of gold necklaces said to have been worn by African princesses, and some twisted gold rings such as savages wear in their noses. Many of those articles would have been highly prized by curio seekers, but the owners were either too ignorant or too needy to attempt to sell them to private parties."

"Do you receive much plate now?" we inquired.

"We get some silver pitchers, spoons and forks occasionally, but not nearly as much as we received during the war. With the exception of the very rich people there are few families who still retain any solid gold or silver ware. It was all melted up long ago. Such things are too valuable to keep." "Yes," added Superintendent Mason, "that is true in this country. Solid gold is too valuable for use either as dishes or as ornaments in this country. It all eventually finds its way to the melting pot. Plated gold is the only thing that lasts for household use."

A peculiar feature of the business at the Assay Office is the large quantity of gold and silver coin which is constantly being converted into bullion at the request of corporations and business men. Heavy packages of bright, golden eagles, almost fresh from the Government Mint, are brought to the Assay Office to be melted and run into bullion. Merchants say that they can do nothing with the bulky coin, and, therefore, prefer the gold bars, which can be more readily converted into paper money. Silver dollars are being melted up every day. Many persons into whose hands they fall in inconveniently large quantities gladly suffer a loss of \$151 on each \$1,000 of the silver dollars in order to get rid of them.

Repairing Watch Cases.

[By W. SCHWANATUS, Berlin, Prussia, in *Deutsche Uhrm. Zeitung*.]

Continued from page 241.

IF IT IS found, when putting the case together again, especially old ones, that the old joint pins can no longer be used, a thing of frequent occurrence, put in new ones, always using tombac pins for gold cases, and German silver ones for silver cases. Take wire of a size fitting to the joint, file the former a little tapering at one end; the pin must be of the shape of a broach. When the pin is filed, and it is found that the bottom or rim moves firmly with it, and that the pin in the middle joint turns with it (this is important, and especial attention must be paid to it), shorten the wire at the ends of the joints, file the pin even with it, and round the ends; it is advisable to take the joints of a good case as pattern. The main thing is that the pin is rounded off equal and uniformly with the joints, so that no corners or edges protrude; it may finally be ground off and polished with the joints.

The pin must, when the bottom or rim contains two joints, always turn with it, that is, the two joints must carry it along. It is not very easy to file a good pin, and it often has its difficulties, wherefore it is well if I give a few additional directions: If it is found that the pin, after it fills the joint completely, will not turn with the two end joints, it is due to the fact that the middle joint is not well opened by broaching and hinders the pin in its free motion. It is commendable in this case to widen the center joint a little with the filed

pin, by pressing it carefully into it. The desired end will generally be obtained hereby, and the pin turn. It is a matter of great consequence to force in the bottom pin as tightly as possible into the joints, since it is of great service to the snap of the bottom, if the pin enters very tightly. Pay strict attention not to leave the wire too thick at the end, because by such a neglect the repairer might force open the fore-joint.

Whenever the joints admit of it (that is, if they are still strong enough and sufficiently long), three pins can be inserted, whereby do as follows: File a pin exactly fitting to the joints, and if the bottom moves firmly with it (it is immaterial whether the pin moves with it or not), mark the pin with a small file at the ends of the joint, draw out the wire again, and shorten it at the marked places. Next divide the pin in three equal parts, and arrange the middle piece in such a manner that one-third stands beyond the middle joint; the division may very well be measured from the outside. If you have the requisite length (I call especial attention to the fact that the middle pin must neither be too short nor too long), file the pin a little at the ends, so that it retains no burr; set the bottom upon the middle part, and carefully insert the pin into the joints. First use a pair of flat pliers for the purpose and finish with a punch. It is thus in one's power to make the bottom as firm as is desired. The ends are finally filled out with wire, generally using the same one for the purpose. It is filed flat, the burr removed, and the ends are firmly filed with it; if the pin cannot be withdrawn, it shows that it is sufficiently firm. It is pinched off with the nippers, filed flat, and then nicely rounded off with the joints.

SOLDERING THE BEZEL.

It happens occasionally that the soldered ends of the bezel burst open, either from insufficient soldering or from forcing in a crystal; this is a piece of work which the watchmaker can very well do himself.

To solder the bezel again do as follows: Scrape the place to be soldered very carefully with a graver, or, in case that the bezel should be sufficiently wide, with a fine and not very sharp file give a stroke over the ends, which, of course, must be done very carefully, so that not too much is filed away. Then take a piece of binding wire, and lay a few loops of it around it; before it is tightly drawn on, however, take a piece of iron wire of such a size that it fills the glass groove and reaches a little beyond the ends, bend the wire to correspond to the groove, and lay it in, after which the piece is carefully tied crossways by means of the binding wire. The warping or bending of the bezel is prevented by placing in the piece of wire. When it has been tied sufficiently tight put on some borax, outside as well as within; place a piece of solder into the interior, and solder carefully. It must be remembered, as a matter of great importance, that the bezel is to be first glow heated at the place opposite to the break, whereby its elasticity is overcome, and only after this pass around to the solder with a small and quiet flame. Soldering effected, remove the iron wire and pickle. When done, and a little solder should be noticed either in the glass groove or on the outside of the bezel, remove it with a small file from the latter, and cut it out of the former with a graver. The bezel is finally ground with pumice stone and wood, then polished, and fastened again in place.

THE CLOSING OF THE CASE.

In order to produce a good snap on the case, it is first of all necessary to find out why the case will not close. Do not by any means commence to work, especially with weak cases, without reflecting well where aid is best to be rendered. Cases with this ailment are oftentimes very annoying, since a certain well-defined system of work can frequently not be followed, and the repairer must often have recourse to tricks to obtain his ends. I will, therefore, endeavor to at least try to give the best possible directions I am able to. If the case is so defective that bezel, dust-cap and bottom will not close—which often happens—take the case entirely into pieces, and inspect first the middle part. If this is so weak

that it can be pressed together by the slightest pressure, and must, therefore, be strengthened from within by soldering either a piece of metal against it or flowing it with solder, it is better for the watchmaker not to attempt its repair, and to give the case to some case-maker, because I would not by any means advise him to undertake such a job. If the middle part is sufficiently strong, however, and has been pressed together only by careless handling, he may attempt the correction of the closing in the following manner: Pick out a stake with as thin an edge as possible, fasten it in the vise, and by means of a riveting hammer, holding the stake into the middle part, seek to raise the outside snap edge by careful taps; the bezel closing may be commenced first. It is necessary, however, to pay strict attention to that the middle part is in as round a condition as possible; should it be out of round or bent out of shape, endeavor, before you expend any labor upon it, to first get it very nearly back to its original shape. It is highly necessary, when doing such jobs, that the repairer proceed with the greatest caution and coolness, since ends are easiest attained in this manner. When the closing has been raised up and the middle part is round, take a small gentle file, and carefully go over the closing at the middle part with it; only very little assistance with it is necessary, and a favorable result will at once be obtained. If the rim still closes very loosely, so that it opens by the least touch, and the closing of the middle part is in order and regular, seek to beat the rim with a riveting hammer together. On no account use pliers, and seek to pinch the rim together with them, as is frequently done.

After the rim has in this manner been reduced to closing, examine the dust-cap; if this is round but only closes very lightly, beat upon the closing with a riveting hammer, by making the cap snap tighter by very light taps upon the extreme outer edge. Also in this instance, as in every other where the correction of the closing is involved, I must warn against the use of pliers, because it is an error to suppose that ends are quickest obtained by bending and twisting; on the contrary, the only effect of this work is that the case is seriously injured by the operation. If it is found that the dust cap closes very lightly—in fact that it will not remain shut—examine the closings, and it will be found very often, principally in cases with brass dust cap, that the snap of the cap is not sufficiently under-turned. In this case take a small graver, and correct the closing of the cap with it, and the result will in most instances be found satisfactory. But do not work with the graver upon the width of the closing, but upon the depth. Of course the graver must not go too deep in the operation, otherwise the entire closing would be cut through, the most trifling correction is enough in the majority of cases. If the snap of the dust cap at the middle part is pressed together, or if the closing does not lie high enough, it may also be raised by means of the riveting hammer. It is well for such kinds of work to file a pin which firmly enters into the joints, and to test the closing with it, because it is a matter of great importance that the parts which are to be reduced into closing also move firmly in their joints, and do not shake to and fro. The pin wire is left sufficiently long, so that it may be taken out and inserted with the pliers. It becomes sometimes necessary to underfile the cap closing at the middle part with a file. Having corrected the closing of the cap in this manner, test the bottom. It is very often necessary with this part to first straighten the bottom rim, and to take out dents, because by watches that have been worn the cases are very often all out of shape. It is necessary first to restore the rim into its correct position, and after that examine the joints, which are generally out of order at the same time. Should these latter be twisted out of place, fit a firmly-entering pin into them, leave it in the bottom joints, then take a dull pliers and bend them back. By cases without spring snap it is of no injury if the joints are bent a little more than necessary, especially in old cases.

(To be Continued.)

Development of Watchmaking in Spain.

IN OUR August number we examined the art of Spanish goldsmithing in a cursory manner, and we pursue our inquiries this month in the domain of Spanish horology. It is well known that during the reign of Ferdinand and Isabella, therefore, of course, at the time of the discovery of America, art and science flourished in Castile, and in this respect it was one of the foremost countries of the age. But the large shipments of gold and silver began to arrive from America; the people became more and more enervated, and in the course of the seventeenth and eighteenth centuries, the manufacture of scientific instruments retrogressed gradually, so that toward the end of the last century the scientific and professional avocations were at a lamentably low state. It was at the time of the invention of the chronometer, and the celebrated Spanish admiral Mazarredo endeavored to forward the mechanical art, at least in one branch, which is of the utmost importance for shipping—the manufacture of chronometers.

Harrison in England, and LeRoy in France, had made their inventions, calculated to hand down their names to a deathless fame, but Spain possessed no artisan capable of manufacturing a chronometer. The Spanish marine had purchased ten chronometers from Louis Berthoud, and when four of them required cleaning there could not be found a watchmaker in all Spain to undertake the job; they had, therefore, to be sent to Paris, where they arrived in such a sad condition that the repairs cost as much as the purchase of four new ones. As early as 1765 Don Jorge Juan had pointed out the necessity of sending two or three Spanish watchmakers to London, to acquire at least the practice of cleaning and repairing the instruments. Humiliated at this self knowledge of inferiority, Admiral Mazarredo interested himself in this affair for political reasons. Spanish bibliographers have ignored the eminent services of this distinguished man to create a Spanish navy. There was a small horological school at Barquillo, and Mazarredo picked out the most skillful and diligent pupil to educate him in France and England at the expense of the country. A poor boy, who supported his widowed mother, by the name of Cayetano Sanchez, born in Madrid, was recommended by the Conde de Florida Blanca. On the 19th of April, 1789, Sanchez signed a contract with the Department of Marine, and we append its main features: The Spanish Government binds itself to furnish the ways and means to Sanchez for perfecting himself in the art of horology. He is to go to Paris and enter into an apprenticeship of three years with Louis Berthoud. The expenses of the journey are to be borne by the government; beside this he receives a monthly stipend of 300 reals (1 real=12½ cents) during the first year; of 400 reals during the second year, and of 500 reals during the third year of apprenticeship—his mother to receive an annual pension of 1,825 reals. Sanchez on his part engages, after his return to Spain, to maintain in good order all the clocks of the Royal Marine Observatory in Cadiz, for which he is to receive an annual remuneration of 12,000 reals. A clause was subsequently added to the contract whereby he was permitted to open a private workshop, for which permission he engaged to repair all the clocks of said observatory simply at cost prices.

Sanchez went to Paris in the month of May, and eight months afterward Berthoud reported to the Spanish minister for the marine that the young man would complete his apprenticeship in another year. Indeed, after the lapse of that time Berthoud had the pleasure of reporting that Sanchez had thoroughly mastered the theory as well as the practice of chronometer construction; that he had made two of them with his own hand, and was able to calculate tables of temperature for the various movements; that he was also provided with all the utensils necessary to establish a workshop in Cadiz. Berthoud received for his trouble a fee of 20,000 reals. Sanchez was then sent to London to enter into further studies with the horologist Emery, who declared himself willing to receive the young man, and demanded a bonus of £200 for his trouble, and that Sanchez promise not to establish himself in business in Eng-

land. The latter remained one year in London, and before his return he received additional 39 334 reals, wherewith to purchase instruments and utensils.

The young man, now twenty-four years old, returned home in March, 1793; he presented to the king a watch made by him, for which he received 6,000 reals, and entered into service at once, exhibiting such a degree of skill that he was made court watchmaker in 1798, whereby he was entitled to wear the court uniform.

Mazarredo was not yet satisfied with this his success, and intended to establish a higher horological school and make his protégé its preceptor, but, unhappily, Sanchez fell a prey to the pest in the year 1800, when he had barely arrived at man's estate. He had instructed one pupil, who also met the same fate.

Already, before Sanchez's death, the government had sent another young man, Antonio Molina, into foreign parts, who should also be educated in the art of horology, who also died soon after, as did his successor, Carlos La Rue.

It appeared as if an untoward fate intended to render futile all the good projects of the Spanish government, but Admiral Mazarredo did not despair. Two other young watchmakers, Agostin Albino and Blas Muñoz, were sent to Paris, in order to be educated as chronometer makers according to a plan draughted by Berthoud and sanctioned by Mazarredo. The time of apprenticeship was fixed at four years; the first year was to be devoted to the crudest mechanical labors; during the second year the finer construction of the watch parts, their composition, adjustment, was to be studied; theoretical studies were to be made in the third as well as inquiries into temperature and air pressure, compensation, peculiarities of the balance spring, etc., while the fourth year was devoted to the manufacture and perfecting of fine clocks and watches. This instruction was to go hand in hand with the teaching of mathematics and drawing.

They finished their studies in the year 1805, but received permission to remain for some time longer in Paris, in order to complete a chronometer and an astronomical clock, which they had commenced and desired to finish before their return. They landed in Cadiz in 1806; and were at once appointed royal horologists, with a salary of 12,000 reals. The same restrictions were imposed upon them as formerly upon Sanchez, and they also received directions to submit plans for a higher horological school.

Expectations were not fulfilled, however, partly due to the invasion by the French under Napoleon, and partly to the petty strife and quarrel between them. In spite of this Albino constructed two clocks and three new chronometers, and educated two able pupils, before he died in 1813. Muñoz remained. The Russian ambassador at the Spanish Court endeavored to persuade him to go to Russia, offering him a large salary, but he could not summon fortitude to leave his native country; he established himself in business in Madrid, where he died in 1823, after having constructed various clocks and educated a few good pupils.

The endeavors of the Spanish government to advance the home manufacture of chronometers, therefore, were unsuccessful, and it appeared that a strange fatality attended every effort. After the death of Muñoz the office of Horologist of the Cadiz Observatory was at the demand of its director, Don Julian Cavelas, abolished, and the government continued to obtain its chronometers from foreign countries.

Nickel Plating.

[By R. HARTMANN, in *Neueste Erfindungen und Erfahrungen.*]

NICKEL PLATES and sheet nickel are now generally made by the manufacturers of nickel ware. These may be used in the production of a solution which is particularly well adapted for nickel plating. To this end the nickel is placed on a perforated board in a saturated solution of ammonium chloride (sal ammoniac),

and the metal brought in connection with the positive pole of a strong battery. By the influence of the electric current the metal dissolves gradually, and a double salt is formed (nickel ammonium chloride), which settles at the bottom of the vessel, while at the same time the metal is kept continually in contact with the ammonium chloride.

If the nickel has previously been weighed the amount of the metal which has become dissolved can at any time be ascertained by weighing the as yet uncombined nickel. In order to nickelize with this solution, a plate of pure nickel is suspended in the fluid, and it is connected with the positive pole of the battery, while the metallic body, which is to be coated, and which must, of course, be well cleaned, is connected, after it has been immersed, with the negative pole. The nickel is precipitated from the solution as a bright coat, whose thickness depends upon the length of time during which the current is acting upon it, and also upon the strength of the latter.

In order to operate directly with the nickel sulphate, it is necessary to have a salt entirely acid free, which may readily be prepared by adding a small quantity of sodium hydrate (caustic soda) to the solution of the commercial salt, after having first removed the copper in a manner which will presently be described. When the acid is neutralized, an apple-green precipitate of nickel hydrate is formed, which is boiled for some time and then filtered. The solution is now perfectly neutral.

To remove the copper from the nickel salt, the latter is first dissolved in water and acidulated by a few drops of sulphuric acid (commercial nickel sulphate is generally acid); then a current of hydrogen sulphide gas, which is prepared by pouring sulphuric acid over iron sulphide in a flask, is passed through the solution.

The copper and other metals which are likely to be present are thrown down in the form of a black precipitate. When the odor of the gas is distinctly recognized its passage is stopped, and the solution heated to expel the last traces of the hydrogen sulphide. It is then heated to boiling in a porcelain vessel with the addition of some metallic nickel. By this means the free acid is neutralized, and on evaporating to crystallization there remains a salt sufficiently pure for nickel plating.

The articles which are to be plated are suspended in the solution which we have just described, and they are connected with the positive pole. A nickel plate, which also dips into the liquid, is connected with the negative pole, and from time to time the liberated acid is neutralized by the addition of a slight quantity of ammonium hydrate. It is better still, for practical results, to spread a layer of nickel oxide over the bottom of the vessel in which the nickelizing is being carried on. This will dissolve in the free acid, and the solution will, therefore, remain neutral and of uniform strength.

The nickel oxide is prepared by completely saturating a solution of nickel sulphate with caustic soda, washing the precipitate and then drying it. The nickel oxide thus formed is a heavy powder of an apple-green color, and may be either spread over the bottom of the vessel, or else it can be placed in a linen bag and suspended in the liquid. If a solution of nickel sulphate, acidulated with sulphuric acid, is poured into a saturated solution of ammonium sulphate, crystals will separate out, consisting of the double salt of nickel ammonium sulphate. The crystals are washed with cold water, dissolved in hot water, and then the solution is completely neutralized with ammonium hydrate. It is then allowed to stand for several days at a temperature of 20° to 25°, until no more crystals separate out. It is also of importance that the liquid be maintained at this temperature during the nickelizing, for otherwise the nickel will not adhere firmly to the metal.

During the operation of plating, a sheet of nickel, connected with the positive pole of the battery, is suspended in the solution. According as the nickel becomes separated from the solution the sheet dissolves, and thus the solution maintains its original strength. Plates of absolutely pure nickel are at present quite expensive, in consequence of the very high temperature which is required for their

fusing and casting. By the addition of $\frac{1}{5000}$ part of phosphorous its point of fusion is quite lowered. As the phosphorous is not objectionable in nickelizing, the plates are generally made of metal containing phosphorous, and they are used to the best advantage in rather thin sheets; because, the larger the surface of the nickel plate, the less will be the strength of the current required, and when the pieces to be plated are not large, as will occur in the majority of cases, two or three Bunson elements will be sufficient.

In addition to the above methods for nickel plating, others have been proposed which also give good results, but which require more expensive preparations than those previously mentioned; thus, for instance, the double salt of nickel potassium cyanide and solution of nickel nitrate have been proposed. On account of the vapors which escape from the cyanide solutions, although only in small quantities, they are particularly objectionable, and, therefore, the employment of cyanide preparations, on account of their poisonous properties, should be avoided whenever it is possible to do so. The nickel nitrate gives a beautiful and durable coat of nickel. The solution is most effective when it is composed of 4 parts of crystalized nickel nitrate, dissolved in 150 parts water, to which 4 parts of ammonium hydrate are added, and then 50 parts of the acid sulphite of sodium are dissolved in the above solution.

The acid sodium sulphite is prepared by heating sulphuric acid in a retort; the gas produced is passed through a small quantity of water, which will retain the copper which has been mechanically carried over, and then the gas (sulphuric acid) is dissolved in water until the liquid smells distinctly of burning sulphur. The solution which has thus been obtained is divided into two portions: one part is saturated with sodium carbonate as long as effervescence takes place, the other half of the acid is then added, and in this manner the bisulphite of sodium is produced. This must be employed as it is, because it is impossible to crystalize the salt by evaporation, for in so doing one-half of the acid would escape, and the mono-sulphite of sodium would remain behind.

For nickel plating of the finest kind, such as is produced in American factories, a solution is prepared from the nickel nitrate and acid sodium sulphite. It sometimes happens that the nickel will strip or peel off from the metal on which it has been deposited. It is said that this objection can be overcome by placing the dried plated objects into a bath of oil, and heating them up from 250° to 270° .

According to Weston, a plating of great beauty and durability is obtained by mixing a solution composed of 5 parts nickel chloride and 2 parts boracic acid, and then adding, while continually stirring, sodium hydrate (caustic soda) until the precipitate is redissolved.

Views of Correspondents.

This department of THE CIRCULAR is open for communications relating to the jewelry trade, but the editor does not hold himself responsible for the sentiments expressed by contributors. We invite correspondence, but require that it shall be free from all personalities, and the writer's integrity guaranteed by the disclosure of his true name to the editor. Anonymous communications will not be noticed.

To the Editor of the Jewelers' Circular:

Please tell me in the next issue of THE CIRCULAR the size of the smallest watch that you have on record. Give me the maker's name and where it was made. I am now constructing a stem-winding watch which, when finished and in the case, will measure one-half inch in diameter.

C. W. L.

Newburg, N. Y.

[There have been many small watches made by ingenious workmen. Matile made a six line stem-winder which was set in a ring. It was about the size of a three cent piece. J. J. Badolet & Co. had a 4-line stem-winder which attracted considerable attention. Louis Richard, Locle, in 1865, made a 6-line repeater. Henry Copt had a 4-line watch set in the head of a pencil case in his exhibit at the

Centennial Exposition. It was about $\frac{3}{4}$ of an English inch in size. Edward Hunzeker, of L. H. Keller & Co., of this city, is at work on a stem-winder measuring only 3 lines. So you can see there are several much smaller watches than yours.—ED.]

To the Editor of the Jewelers' Circular:

I have of late read THE CIRCULAR with a great deal of interest. It is a splendid paper, and splendidly managed, and full of good sound advice and instruction for poor country watchmakers. I have been a careful reader of THE CIRCULAR for the last twelve years and find that the grand old paper improves in tone and sentiment year by year—you are doing a good work for the trade. The best work THE CIRCULAR ever did was when it burst up the so-called Guild. What a nice scheme it was for the manipulators to get into the wholesale business on? All they wanted was to get a following so that they could say to capitalists, "We can control the retail trade of the west; let us start a stock company and make Guild stamp goods." They would make their little "rake" in stock, and keep up the music as long as the retailer would dance. I see in the September number that you ask after the funds of the late Guild. It would be kind of interesting to know who raked the last pot. R. Illinois.

To the Editor of the Jewelers' Circular:

I have read your recent articles on diversified stocks for jewelers with a good deal of interest, and I feel sure that you have solved the problem. At first I thought your suggestions for jewelers to introduce a line of goods of which they knew nothing, in order to get square on the outsider who handled jewelry, a very unwise thing to do; but I am now thoroughly convinced that it is the jewelers' only salvation. I have been in the jewelry business for the last twelve years, and until quite recently kept nothing but gold and rolled plate jewelry and watches, but I was so impressed with the good advice you gave that I thought I would lay in a small stock of perfumery and fancy stationery as I found the druggist in our place was dealing in jewelry as well as these articles. Well, I am more than satisfied with the experiment. I am now laying in my third lot, and I find that these goods pay better than jewelry. Moreover, where I had one customer visit the store I now have three or four, and find that one article helps to sell another besides making my store more attractive to customers. Mr. Editor, you are doing a good thing for us poor jewelers; keep it up. I advise every jeweler in the country to read THE JEWELERS' CIRCULAR carefully every month. I would not be without it for \$100 a year, for I have made more than three times that amount by following its advice.

Pennsylvania.

C. T. THOMPSON.

To the Editor of the Jewelers' Circular:

You would doubtless confer a great favor on your numerous subscribers if you would tell them where to get rolled plate goods that will not tarnish or turn black after a few days' wear. It seems almost impossible to get hold of any rolled plate chain or bracelets that will hold their color even in the window or show case. A few days ago I had a lot of rolled plate chain for It was apparently good stock and I thought I had struck the kind of goods we used to have twenty years ago. I hung a few chains up in the window and laid the balance away in the show case, but after three days' exposure they showed signs of tarnish like the rest of the trashy stuff. I have spoken to several of my fellow craftsmen and find that they all have the same experience with rolled plate goods, no matter what price they pay for it. Is it possible that there are no reliable rolled plate goods made nowadays? If there are will you tell us where to get them?

K. S. M.

Pennsylvania.

To the Editor of the Jewelers' Circular:

Your views on the course the trade should take to combat some of the great evils growing out of the distribution of catalogues and other causes has been carefully considered by me. Though I don't agree with you in many things, yet it is well for the trade to under-

stand both sides of the question. For my own part I will follow your advice and get a stock of musical instruments, fancy goods, etc., in addition to my regular stock of jewelry and watches. I have bought a store and will occupy it about October 1st. F. L. Z. Alabama.

To the Editor of the Jewelers' Circular:

I wish you would caution the trade to beware of a class of peddlers who are going about the country selling bogus watch material, or rather imitation American material, that will get the watchmaker who uses it into no end of trouble. There is a house in your city that deals extensively in this stuff, and it is the worst trash I ever saw. Of course they sell it cheap, but it is dear at any price. The material I speak of is evidently an imitation of an imitation American material, and I wonder the watch companies don't try to stop its importation as they do imitation American watches. You will confer a favor on the country watchmaker by keeping him posted on matters of this kind. M. J. L. Ohio.

To the Editor of the Jewelers' Circular:

I have for several years read the complaints of country storekeepers in regard to jobbers' catalogues, travelers selling jewelry to guests at hotels and outside dealers, etc. All these things are, of course, very annoying to dealers, particularly in those sections of country where this sort of thing is the rule rather than the exception. But the greatest nuisance of all is the traveling auctioneer, who, backed by some irresponsible jobbing house that furnishes them the goods or are interested in the enterprise, visit every town and village in the state and auction off their stuff. When these sharpers strike a town they get hold of some unoccupied store and placard the town with posters, and circulate handbills, stating that a large bankrupt stock of jewelry and plated ware will be sold at any price to close the business. The class of goods these sharpers sell is the worst trash conceivable, and such goods as no respectable jeweler would keep. But the "Toodles" are not all dead yet, and the smart greenhorns who are always on the lookout for a gold dollar for five cents, don't know the difference until after these rogues have left the town, and then it is too late to complain. One would think that these simpletons would not bite a second time, but they do a third and a fourth time, and get sold every time. Let a resident dealer only sell one of these people a plated chain that tarnishes or blackens a white vest, and they are ready to clean out his store and denounce him as a fraud. The experience of "L. R. D." in the September issue of THE CIRCULAR is the experience of thousands of others similarly situated, and I don't know how we are going to stop it unless we can get town authorities to increase auction licenses enough to keep them out of town. H. C. H. Empire State.

To the Editor of the Jewelers' Circular:

From an item in the August number of THE CIRCULAR I judge that you are somewhat skeptical in regard to diamonds being found in this country. Some years since a laborer found one in a placer mine on the property of C. Leventhorpe in Rutherford County, North Carolina. It was very small and of bad color, but a veritable diamond nevertheless. It was sent to Prof. U. Shepard of Amherst, Mass., who pronounced it a diamond, and gave it a place as such in his cabinet. Several other diamonds have been found in North Carolina. The late D. J. Twitty of Spartanburgh, had one. This stone also came from a mine in Rutherford County, N. C. Dr. Hunter of Lincoln County, N. C., also found a small diamond. It has a somewhat bluish tint. A few years since Mr. D. J. Twitty had a fine diamond, which he had cut, and which was valued at about \$400. It came from a placer in South Carolina. It passed from its place in the shirt bosom into the possession of a New York pick-pocket, who stole it from its owner while in a Seventh avenue car. Numerous diamonds have been discovered in Georgia. After the war, during the prevalence of a "mining fever," a company was

formed for exploring the diamond washings. Nothing further of this enterprise was heard however. Mr. C. Leventhorpe of Patter-son, N. C., owns a rough diamond, taken from a "Long Tom" in White County, Ga. It is of very perfect water and crystallization, and weighs exactly three grains. For the information of the unin-structed, it may be said that the "Long Tom" is a narrow plank trough set with a steep pitch. An iron grating at its lower end closes it so as to form an obtuse angle. The dedritus from the gold-bearing streams is shoveled into this box, and a second operator stirs it with a shovel under a small stream of water. The coarser gravel is thrown out. The gold, and such small gravel as may possess a superior gravity, do not pass off with the current. It was thus that this diamond was discovered. C. W. S. North Carolina.

Filigree Jewelry.

(Continued from Page 234.)

THE WILD Thakurs and Katharis of Matheran, and the Western Ghats of Bombay, wear grass collars, necklaces, bracelets, ank-lets and girdles in exact imitation of the gold jewelry of thick gold wire, twisted into girdles and other ornaments of the same kind, which have, from time immemorial, been worn all over India. These gold collars were also worn by the ancient European nations, especially the Gauls, and called by them *torque*. The Burmese manufacture a peculiar necklace, the style of which is identical with the Matheran necklaces of twisted and knotted grass; they sometimes consist of tubular beads of gold strung together and pendant from a chain which goes around the neck, the strings of tubular beads of gold hang down in front, like a golden veil. At other times the gold is fashioned in'o flowers or replaced by strings of pearls and gems.



FIG. 1.

The women, in the wilder parts of India, where the heat is very

excessive, frequently dispense with clothes altogether, and wear the fig-leaf of Eve's days; the wealthier class have it of silver, but all preserve the heart shape of the leaf, no matter of what metal it is made. These silver leaves are suspended from the waist, the poorer class using a simple thread, and the wealthier ones a girdle of twisted silver ornamented with a clasp in shape of a serpent's head. This ethereal style of dress is adopted by many nations of the tropic zone: Algerian girls, for instance, also wear a heart-shaped silver ornament until the time that they require more modest attire.

The Indian jewelers imitate with preference fruits, leaves and flowers for necklaces, ear rings and ornaments; the mango and the chrysanthemum are met with in various convolutions; the bell-shaped ear ring, with smaller bells hanging within, is patterned from the sacred lotus flower, and the cone-shaped ear rings of Cashmere, in ruddy gold, represent the lotus flower bud. It is possible that this imitation of flowers is not prehistoric, but, at any rate, it has come down from very early times. The lotus is also imitated by other nations; the Chinese and Japanese use it with preference in their decorations, and it is often met with in Assyrian and Babylonian sculpture.

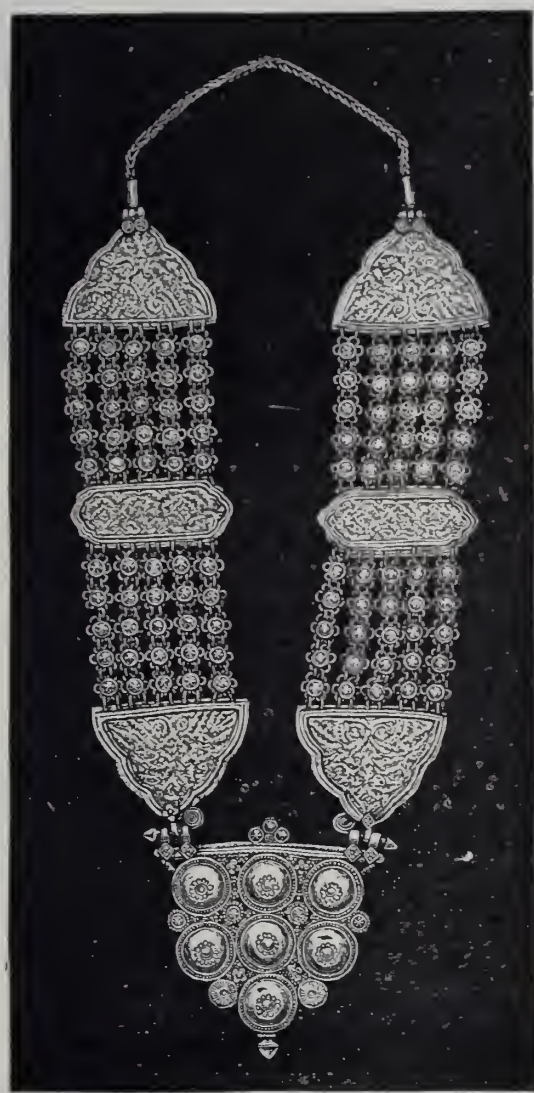

FIG. 2.

Another form of gold ornament—that of chopped gold, and which is perhaps as primitive as the twisted gold wire, is also worn throughout India; the goldsmiths of Ahmehabad and Surat of Western India are held to be the most skillful in this line. It is made of chopped pieces of the purest gold, flat or in cubes, and, by removal of the angles, octahedrons, and strung on red silk. It is the finest jewelry of India. The nail-head ear rings are identical with those represented in Assyrian sculptures. It generally consists of solid gold, for the people of India hoard their wealth in the shape of jewelry; but it is also made hollow at Surat, the flat pieces and cubes, etc. being filled with lac or dammar.

The beaten silver jewelry of the Gonds and other wild tribes of the plains of India, and valleys of the inner Himalayas, is also very primitive in character. The singular brooch worn by the women in Ladak is identical with those found among Celtic remains in Ireland and elsewhere. It is formed of a flat and hammered silver band, hooped in the center, the ends curling inward on the hoop. It is very probable that the shape is due to the symbols of serpent worship. It is, at any rate, of too artistic a design to have been devised by the uncultured Celts of that day, and they very probably brought it with them in their migration from the east.

We find another custom prevalent in India which was shared in former times by the Romans; we have reference to the gold or silver waist belt worn to gird up the cloth around the legs; and, as in Rome, when the ceremony of changing the *toga praetexta* for the *toga virilis* was performed, the *aurea bulla* was taken from the boy's neck and consecrated to the domestic god Lar; so in India, at the ceremony of investiture with the sacrificial thread, an identical ornament, a hollow hemisphere of gold, hung from a yellow cotton thread or chain of gold, is taken from the boy's neck, and the sacred cord, the symbol of his manhood, is put on him.



FIG. 3.

An amulet or talisman, composed of nine gems, generally a coral, topaz, sapphire, ruby, flat diamond, cut diamond, emerald, hyacinth and carbuncle, is certainly suggestive also of some connection with the *Urim* and *Thummin*, or sacred oracle of the Jews, taken by Chosroes II. from Jerusalem, A. D. 615, and probably still existing among the ruins of one of the old Sassanian palaces of Persia. This ancient ornament gave its name as a collective epithet to the "nine gems" or sages of the Court of Vikramaditya, B. C. 56. In books the nine gems of the amulet are said to be pearl, ruby, topaz, diamond, emerald, lapis-lazuli, coral, sapphire, and a stone, not identified, called *gomeda*. The tri-ratna is the triple-gemmed "Alpha and Omega" jewel of the Buddhist, symbolical of Buddha, the Law, and the Church.

There is no nation whose art of jewelry and goldsmithing is as old as that of India; not alone have the forms of Indian jewelry, but also the chasings, embossments and ornaments decorating them, been handed down in an unbroken tradition from the most remote antiquity. The light of Aryan civilization first dawned in the Ganges Valley, and spread thence into that of the Tigris and Euphrates. The civilization of Egypt was more ancient, but it was undoubtedly largely influenced by Assyria and India influencing them in turn; the civilization of India, Egypt, Assyria, as well as that of Greece and Rome, have mutually acted on each other, not alone in the earliest ages, but throughout all ages, through the Arabs, Phœnicians and Armenians. The earliest records, the national epics, and ancient sculpture and paintings, all represent the Hindoo forms of Indian jewelry, gold and silver plate, common pottery and musical instruments, and describe them exactly as we have them at present.

The Rig Veda constantly mentions jewelry. "The Maruts decorate their persons with 'various ornaments,' they are richly decorated with ornaments; shining necklaces are pendant on their breasts." The Aswins are adorned with "golden ornaments," and the Asuras likewise have "plenty of gold and jewels." The sage Kakshivat, the reputed author of several of the hymns of the Rig Veda, prays for a son "decorated with golden ear rings and a jeweled necklace," and largesses of "gold and jewels" to the priests and Brahmans are constantly mentioned. Various kinds of jewelry are mentioned by names that are still applied to them in India. Manu minutely defines the nature and duties of the jeweler, and prescribes the fines he is to pay for improperly piercing precious gems, such as rubies and diamonds, or inferior gems; also what punishment is to be meted out to him if detected in debasing gold. References of this kind are too numerous to mention. Sita is represented as arrayed in a light *sari*-like garment, of a rosy-red color, embroidered with gold, for her marriage with Rama, while jeweled butterflies and other bright ornaments decorate her raven hair. Her ears are resplendent with gems, she has bracelets and armlets on her arms and wrists, while a golden zone binds her slender waist, and golden anklets her ankles. She has jeweled rings on her fingers and golden bells on her toes, that tinkle as she walks with naked feet over the carpeted floor. In the Mahabharata, at the gambling match at Hastinapura, Yudhishthira is described as losing first "a very beautiful pearl; next, a bag containing a thousand pieces of gold; next, a piece of gold so pure that it was soft like wax; next, a chariot, set with jewels and hung all around with golden bells; next, one thousand war elephants, with golden howdahs set with diamonds; next, one hundred thousand slaves, all dressed in good garments; next, one hundred thousand beautiful slave girls, adorned from head to foot with golden ornaments; next, all the remainder of

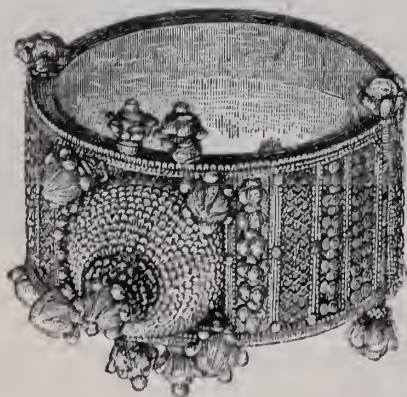

FIG. 4.

his goods; next, all his cattle; and then his whole kingdom, excepting only the land he had granted to the Brahmans." Sudraka, who lived in the first century B. C., or at the time, describes the jeweler's workshop attached to the house of a courtesan: "Where skillful artists were examining pearls, topazes, emeralds, sapphires, lapis-lazuli, coral, and other jewels. Some set rubies in gold, some string gold beads on colored thread," (exactly as is done now), "some string pearls, some grind lapis-lazuli, some cut shells, and some turn and pierce coral."

A very peculiar feature of the Indian jeweler is his consummate skill and thorough knowledge and appreciation of the conventional decoration of surface, by which he contrives to give the least possible weight of metal; gems which are commercially absolutely valueless are endowed with the highest possible artistic value, while, at the same time, he never violates the fundamental principles of ornamental design, nor fails to please, even though it be by an effect of barbaric richness and superfluity. This feature of Indian jewelry is in remarkable contrast with our modern jewelry, in which the object of the jeweler seems to be to bestow the least amount of work on the greatest amount of metal. With us, weight is the predominating character of "high-class" jewelry and gold and silversmith's work. No matter how skillfully we may design our work, the leading idea will always be found to be to make it too thick and heavy; most generally, when the eye of a European in India is attracted by the graceful workmanship of an article, directly, when he weighs it in his hand, he will



FIG. 5.

reject it as rubbish. An English authority says that the Jury on Jewelry at the Exhibition in London, in 1851, actually wrote of Indian jewelry: "It is sufficient to cast a glance on the exhibits of India, Turkey, Egypt or Tunis to be convinced that these nations have remained stationary from a very early period of manufacture. Some of them indeed develop ideas full of grace and originality, but their productions are always immature and imperfect, and the skill of the workman is called to make amends for the inadequateness of the manufacturing process."

We should think it were better to remain stationary than to retrogress from the thin beaten silver of Queen Anne's reign to the present ungainly dead-weight silver and gold manufactures of England, for which customers have to pay four times and more than the value of their weight. The main charm of Indian Jewelry consists in its false appearance of richness and solidity, and flaunting gorgeousness.

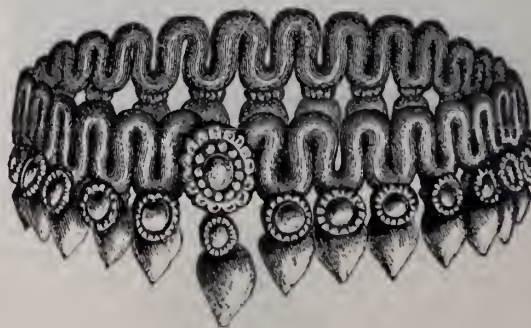

FIG. 6.

For instance, a necklace, or whatever ornament it may be, made up apparently of solid, rough cut cubes of gold, but it is as light as pith; yet hollow, it is not false, being of the purest gold, or it may be a necklace which you would hold to be priceless. But all this glitter of pearls and diamonds, emeralds and enamels, are but a deceitful shine, and have no intrinsic value. The Indian jeweler thinks only

of producing the sumptuous, imposing effect of a dazzling variety of rich and brilliant colors, and nothing of the solidity of his gems.

Cashmere and the Punjab manufacture the finest gemmed and enameled jewelry in India, the Aryan type of which extends to Delhi and Central India, and, in debased imitations, is to be found throughout Bengal. It consists of aigrettes and other ornaments for the head, tires which hang over the forehead, ear rings and ear chains,



FIG. 7.

and studs in imitations of flowers, and of tablets of gold (No. 1) set with precious stones, strung together by short strings of mixed pearls and turquoises, with a large pendant suspended from the middle, gemmed in front, and exquisitely enameled, like all the rest of this necklace or rather collar.

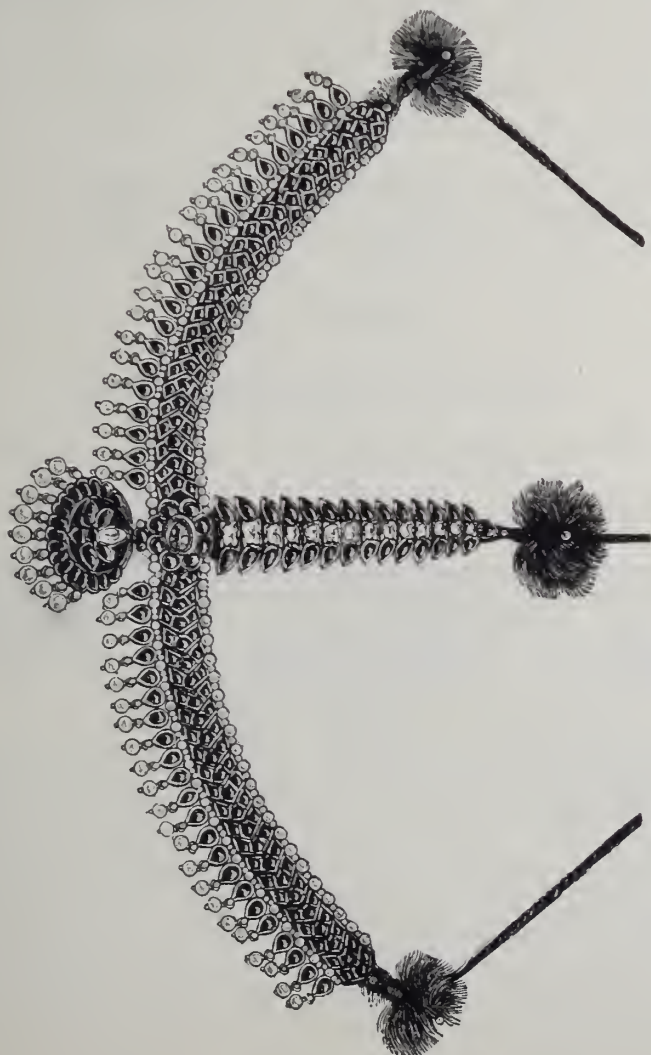

FIG. 8.

The jewelry of Sindh and Beluchistan is similar to that of the Punjab, but is usually found only in its more primitive gold and silver forms (figures 2 and 3). Solid silver *torques*, anklets and bracelets

are very common, of a severe style of rectangular construction and ornamentation.

The silver filigree work of figures 4 and 5, in which the people of Cuttack in Orissa have attained such surprising skill and delicacy, is identical in character with that of Arabia, Malta, Genoa, Norway, Sweden and Denmark, and with the filigree work of ancient Greece, Byzantium and Etruria, and was probably carried into the West by the Phœnicians and Arabs, and into Scandinavia by the Normans, and, in the course also of the mediæval trade, into Turkestan and Russia. In Cuttack the work is generally done by boys, whose sensitive fingers and keener sight enables them to put the fine silver threads together with the necessary rapidity and accuracy. It is quite distinct in character from the indigenous silver jewelry of the country, as will be seen from the illustration given.

Various districts of Bengal also manufacture gold and silver filigree work of great excellence, as well as gold and silver jewelry of all kinds, such as rosaries, bracelets, necklaces, etc., together with silver jewelry. That of Dinajpur is of highly interesting primitive forms (figure 6). The Indian jewelers in general are so skillful at imitating that they can copy a given article so faithfully that it cannot be distinguished from the original. This trait is well recognized, and plays have been written, the plots of which turn on this skill.

The jewelry of Thibet has preserved its primitive character, and a good deal finds its way through commercial channels into India; it chiefly consists of silver ornamented with large crude turquoises, sometimes with coral—in the shape of armlets, necklets and amulet boxes—strung on twisted red cloth or a silver chain; and in various forms, such as bracelets, anklets, etc., hammered, cut, and worked in filigree. Their shape has been handed down from very remote periods, it being identical in character with the jewelry so profusely represented in ancient indigenous sculptures. The women of Ladak wear a curious ornament, which falls from the forehead over the head, down the back to the waist. It is covered with precious stones, and the wearer does not marry until she possesses enough of them to form a good-sized one, which, in fact, constitutes her dowry. The silver Celtic brooch we described above as worn in certain Himalayan regions is also of Thibetan origin.

The Mahommedans and Parsees (descendants of ancient Persia), of the Bombay Presidency, abstain from intermarriage with the Hindoos, and even have ornaments peculiar to themselves—the Mahommedans in the Mogul style of India, and the Parsees of the traditional forms of the Sassanian period in Persia, but wrought by Hindoo jewelers. Unfortunately, being an energetic, advancing people, the Parsees have, during the last fifty years, begun to give up this national jewelry in favor of the fashionable jewelry of Europe. The *repoussé* gold jewelry of Sawantwadi (figure 7) met in mythological designs, is the best in Western India.

We come next to the Madras Presidency, where we find superbly made gold and silver ornaments; several villages are renowned for their manufacture; all their styles are in the mythological designs, characteristic of Southern India. European taste has, in great part, corrupted various designs, but nothing can excel the technical excellence of the rose chains, and heart pattern necklaces and bracelets made in Trichinopoly, of which we give a cut (figure 8); silver filigree work of the best description is produced by the jewelers of various villages.

The jewelry of Ceylon, in filigree, chasing and *repoussé* work, is remarkable for the delicacy of its ornamentation in granulated gold, in the manner of the antique jewelry of Etruria, and for its exquisite finish.

When the Prince of Wales was in India he was presented with a few but exceedingly choice specimens of jewelry, which are to be seen in his collection. The diamonds are particularly interesting. The Hindoos value diamonds in jewelry solely for their decorative effect, but they most extravagantly prize them for themselves as a sort of talisman, and particularly value them when the natural crystal is so perfect and clear that it only requires the cutter's art to have its nat-

ural facets polished. There are some fine Hindoo necklets of pearls and enamel, and "tallow drop" emeralds; and chains, bracelets and pendants starred with gems; but the loveliest jewel of all is a hair comb made at Jaipur (figure 9). The setting is of emerald and ruby Jaipur enamels painted on gold, surmounted by a curved row, all on a level, of large pearls, each tipped with a green glass bead. Below these lovely pearls is a row of small brilliants, set among the elegantly designed green and red enameled gold leaves which support the

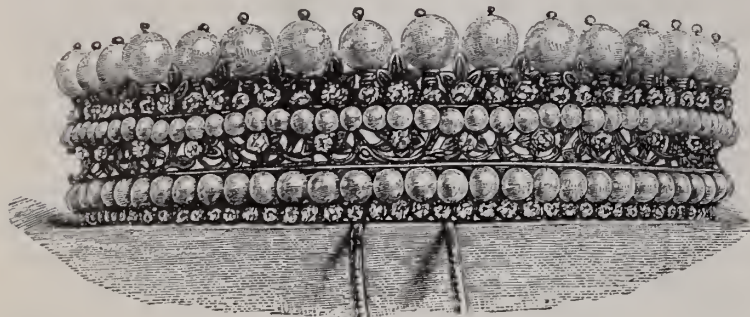

FIG. 9.

pearls; then a row of small pearls with a brilliant-set enameled scroll running between it and a third row of pearls, below which is a continuous row of minute brilliants forming the lower edge of the comb, just above the gold prongs. It is superb in design, and one of the most finished pieces of Indian jewelry that has been made in modern times. The pearls are of very great price, and the whole effect is most brilliant, rich and refined.

We may have, perhaps, been somewhat prolix in the preceding history of the jeweler's art of India; we intended to simply speak of its exquisite filigree work, but found it impossible to separate the two branches of solid goldsmith's work and filigree, without being unjust to the other, and we will speak of its manufacture and treatment in our next.

The Jewelers' Security Alliance.

THIS ADMIRABLE society was organized some months ago for the purpose of protecting retail jewelers from the depredations of the criminal classes, and rendering them effectual detective service in case of safe burglaries, seeking the recovery of the goods and the prosecution of the thieves. The assistance which they propose to render to unfortunate dealers whose safes have been burglarized, is to be given them at the time of the robbery, and when they are less able to afford the expense of a thief chase than at any other time. Scarcely a month passes that from three to five burglaries are not reported of the class which the Alliance proposes to investigate, and as the gangs of burglars doing these deeds are constantly on the road, it is of importance to every dealer that he should have the greatest amount of protection it is possible to obtain. Combined effort will, no doubt, shortly result in the extermination of these gangs of burglars. An individual is not able to cope with these professional burglars, either to recover the goods they obtain or to secure their punishment; it was, therefore, deemed for the best interests of the trade to form an organization for mutual protection, and the Alliance is the result. This has the endorsement of many of the best houses in the trade, and promises to be of great service to its members. At a recent meeting of the Executive Committee the following names were admitted to membership:

David C. Dodd, Jr.; Wheeler, Parsons & Hayes; Hodenpyl, Tunison & Co.; Carrow, Bishop & Co.; Carter, Sloan & Co.; Dorrance, Edge & Co.; C. G. Alford & Co.; Keller & Untermeyer; J. B. Bowden & Co.; Joseph Miller, Parker's Landing, Pa.; David F. Conover & Co., Philadelphia, Pa.; Alex. R. Harper & Bro., Philadelphia, Pa.; J. D. Yerrington & Co., Oppenheimer Bro. & Veith, Kosuth, Marx & Co., Heller & Bardel, Woglom & Miller, A. J. Hedges & Co., John A. Riley & Co., D. & M. Weil, New York City; James

Saunders, Schenectady, N. Y.; D. C. Percival & Co., Boston, Mass.; Brown & Ward, East Saginaw, Mich.; Simons, Bro. & Co., Philadelphia, Pa.; S. Jenkins, New York; Wm. Wise, Brooklyn, N. Y.; D. A. Ainley, Rondout, N. Y.; A. Townsend, Matteawan, N. Y.; Geo. W. Pratt & Co., New York; Myron DuBois, Ellenville, N. Y.; A. C. Benedict & Co., New York; C. E. Rose, Corsicana, Tex.; Welles & Zimmerman, Poughkeepsie, N. Y.; Orange B. Rudd, Ilion, N. Y.; Louis A. Scherr, Philadelphia, Pa.; S. Thomas, Jr., & Bro., Charleston, S. C.; Saxton, Smith & Co., New York; Henry Plumb, Des Moines, Ia.; E. P. Roberts & Sons, Pittsburg, Pa.; H. Muhrs' Sons, Philadelphia, Pa.; D. & M. Bruhl, Marx & Weis, Louis Strasburger & Co., Adolph Schwab, New York; B. A. Bell, New Berne, N. C.; Randel, Baremore & Billings, M. Fox & Co., Champenois & Co., Edwin A. Thrall, Julien Gallet & Co., New York; W. H. Vail, Valparaiso, Ind.; Lyon & Hardy, New York; M. Hendry, Luling, Tex.; M. B. Wright, Kansas City; Stern Bros. & Co., New York; Roehm & Wright, Detroit, Mich.; J. W. Spence, Racine, Wis.; T. Kaempff, Philadelphia, Pa.; Frank S. Kennedy, New York, Geo. C. F. Wright & Co., New York; C. W. Little, Denver, Col.; Aikin, Lambert & Co., G. & S. Owen & Co., New York; Isaac Budicheimer, Philadelphia, Pa.; C. L. Ruth, Montgomery, Ala.; Harwood Bros., Boston, Mass.; A. Wittich, Columbus, Ga.; W. H. Sheaffer, Wood & Hughes, New York; Jas. Fricker, Danville, Va.; Max Freund & Co., New York; Jas. P. Tryner, Denver, Col.; M. W. Shaw, Galveston, Tex.; M. J. Doffelaar, New York; James Fricker & Bro., Americus, Ga.; Bernard Karsch, New York; C. Schemburg, Columbus, Ga.; F. D. Johnson & Son, Lynchburg, Va.; Lissaur & Sondheim, Alfred H. Smith & Co., Baldwin Sexton & Peterson, New York; Henry L. Dole, Haverhill, Mass.; Isaac A. Alling & Co., New York; Spencer Optical Co., New York; Benedict Bros., 170 Broadway, N. Y.; Alonzo Graves, Morristown, N. J.; Krementz & Co., J. T. Scott & Co., F. Kroeber, New York; Koch & Dreyfus, New Orleans; A. Joralemon & Co., Newark, N. J.; Stuart & Shepard, 2 Maiden Lane; J. L. Woelfle, Peoria, Ill.; Stern & Stern, 6 Maiden Lane.

Several applicants were held over for further consideration. For further particulars address Henry W. Heller, Secretary, 12 John street, or Box 3277, New York.

Proceedings of the Horological Club.

A DISTINGUISHED BODY OF WATCH AND CLOCK MAKERS.

One hundred and twelfth Discussion.—Communicated by the Secretary.

[NOTICE.—Correspondents should write all letters intended for the Club separate from any other business matters, and headed "Secretary of the Horological Club." Direct the envelope to D. H. Hopkinson, Esq. Write only on one side of the paper, state the points briefly, mail as early as possible, as it must be received here not later than the eighth day of the month, in order to be discussed and reported in the CIRCULAR for the next month.

THE DOUBLE IMPULSE CHRONOMETER ESCAPEMENT AGAIN.

Secretary of Horological Club:

"Honor to whom honor is due."

Honor, glory—that is the ethereal food of inventors, as you said in your reflection on page 198 in the HOROLOGICAL REVIEW of August, '83—where R. R. Morison claims for Mr. W. H. Lamb of San Francisco, Cal., the priority of a double impulse and double locking escapement for pocket chronometers.

I send you the expired patent papers which will render unnecessary for me to give you more explanations here. You will see by the date, 1861, that it leaves Mr. Lamb far behind as regards priority. My double impulse and double reposing chronometer escapement having never been put to fair trial, I do not intend to advocate it here, except as to one point, and this is: it has but one scape wheel. The idea of three scape wheels (ask the opinions of any good watchmakers), cannot be sustainable. Any watchmaker and mechanical common sense will conclude that the more you go distant from a motive power, the more delicate and light have to

become the parts of any machinery, and that the weight and complications of three wheels, where I do with one, can not sustain the comparison.

I took this and another patent on escapements in 1861. I was then a foreman (examinator, *visiteur*), in the factory of E. Howard (Boston and Roxbury). One of these escapements was an improved lever; with the same title as this. I will send it to you if you desire to publish it. The reason why I did not use these patents is this: After the first gun of Fort Sumpter the watch factory stopped manufacturing. Mr. E. Howard proposed to me to remain on the "staff" at half wages. I did not like the idea of being paid and remaining idle. I took the occasion to restore my health, and went traveling for twelve years in Europe and Africa. When I came back, in 1873, my patents were pretty near expired, and the southern region of the states did not favor horology of precision. I do not blame anybody to invent, improve, modify; and sometimes one idea comes in the world in several points at once, and the most energetic or best able to have his idea materialized, is the victor. In my next I shall give you the history of these escapements, how they came to see the light, how I was surprised to find some part of my idea already put in execution, and how that discovery was to me vexing and pleasing at the same time.

If you want some more explanations about what I send you please ask freely, and in doing so oblige me.

P. S.—I do not, nor ever intended, that the drawing and model I sent to the Patent Office should be the absolute form and shape of such a perfect thing as a scapement for pocket chronometers, but the legitimate equivalents of the improvement may be contained in the modifications. I surely could make half dozen different designs containing the same principles.

PROSPER HUMBERT.

P. O. Box 678, Austin, Texas.

HUMBERT'S IMPROVED CHRONOMETER ESCAPEMENT.—LETTERS PATENT, NO. 539—DATE, FEBRUARY 26, 1861.

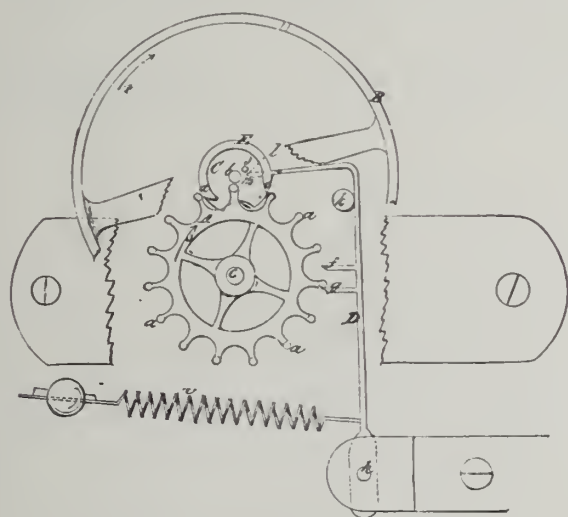

Fig. 1.

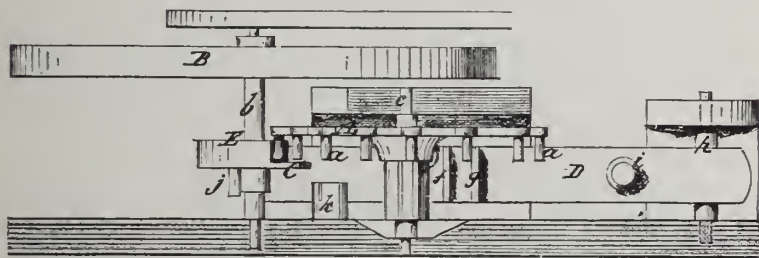

Fig. 2.

Be it known that I, Prosper Humbert, of Boston, in the County of Suffolk and State of Massachusetts, have invented a new and useful improvement in the Chronometer Escapement for watches and other timekeepers, and I do hereby declare that the following is a full, clear and exact description of the same, reference being had to the accompanying drawings, forming part of this specification, in which

Figure 1 is a plan of an escapement constructed according to my invention.

Figure 2 is a side view of the same, partly in section.

Similar letters of reference indicate corresponding parts in both figures.

The escapement known as the "Chronometer Escapement," commonly used as chronometers, and sometimes in watches, possess the advantage over all other escapements in common use, in its having the balance independent of the scape wheel during a greater portion of its vibration, the action of the scape wheel on the balance being continued through but a small fraction of its entire vibration, but in its application to watches it has the disadvantage of the balance receiving an impulse from the scape wheel only in one direction, which renders the watch liable to stop temporarily if shaken suddenly at a certain stage of the operation of the escapement. My invention consists in:

So applying a detent having two locking pallets to operate in combination with two impulse pallets on the cylinder attached to the balance, that the balance receives a double impulse in each complete vibration—that is to say, one impulse in each direction from each tooth of the scape wheel, and that each tooth rests twice in each vibration of the balance back and forth, viz., once against each locking pallet.

To enable others skilled in the art to make and apply my invention, I will proceed to describe it with reference to the drawings:

A is the scape wheel, having its teeth, *a a*, of cylindrical form, projecting from one side of the rim parallel with its axis, and having its spindle, *c*, parallel with the staff, *b*, of the balance, *B*. The hair spring, which is omitted to prevent confusion of parts, is to be applied to the balance in the usual manner. *C* is the cylinder secured on the staff of the balance, very near to the plane of the revolution of the ends of the teeth of the scape wheel, and having secured to it the pallet arc *E*, which is concentric with the balance, and which has its ends so beveled as to form the two pallets *d* and *e*. *D* is the detent arranged to vibrate in planes parallel with the plane of revolution of the scape wheel, and plane of oscillation of the balance on a fixed spindle, *h*; and *f g* are the locking pallets projecting from the detent. The said detent is drawn toward the spindle of the scape wheel and staff of the balance by means of a spring, *i*, but is prevented from approaching nearer to the said spindle and staff than is necessary to lock the teeth of the scape wheel by a fixed stop, *K*.

The extremity of the said detent is beveled on both sides, as shown at *l m* in figure 1, for the action upon it of the lifting pallet, *J*, which is secured to the cylinder, *C*.

The operation of the escapement may be best understood by reference to figure 1. The scape wheel rotates in the direction of the arrow 3 marked upon it. Each of its teeth in turn acts first upon the pallet, *d*, to give the balance an impulse in the direction indicated by the arrow 4 shown near its rim in figure 1, and after it has done this is stopped by another tooth coming in contact with the locking pallet, *f*, where it is held while the balance completes its vibration and until the latter has been returned by the reaction of the hair spring to a position for a tooth that is within and near the arc, *E*, to come into action on the pallet, *e*, when the detent is moved out of the way by the pin, *J*, coming into operation on its bevel, *m*; the scape wheel being now unlocked, the tooth in advance of that which just previously acted upon the pallet, *d*, acts upon the pallet, *e*, to give the impulse to the balance in the opposite direction to the arrow, 4.

This impulse having been given the tooth, which has last stopped by the locking pallet, *f*, falls against the locking pallet, *g*, and the scape wheel remains locked while the vibration of the balance is completed and until the latter has been returned by the hair spring to a position for the pallet, *d*, to be acted upon by another tooth of the scape wheel when the latter is unlocked by the pin, *J*, coming into operation on the bevel, *l*, of the detent, and moving the locking pallet, *g*, out of the way of the scape wheel, and the balance receives a new impulse in the direction of the arrow, 4. It will be understood that every tooth of the scape wheel is in turn locked during one vibration of the balance by the pallet, *f*, and during the succeeding vibration by the pallet, *g*, and every one in turn acts upon

the pallet, *e*, as well as upon the pallet, *d*, but the tooth which acts upon *e* is always the one in advance of that which has previously acted upon *d*.

The drawing represents the balance as being moved in the direction of the arrow, *a*, by the reactive effect of the hair spring, and as being about to receive a new impulse in the same direction by the action of a tooth on the pallet, *d*, the pin, *J*, being about to come into action on the bevel, *l*, of the detent, to unlock the scape wheel from the pallet, *g*. The balance may have a vibration in each direction equal to nearly two revolutions.

What I claim as my invention, and desire to secure by Letters Patent, is:

The combination with the two cylinder pallets, *d e*, attached to the balance of a detent, *D*, with two locking pallets, *f g*, the whole arranged to operate substantially, as herein described, for the purpose of giving an impulse to the balance in each direction, and locking each tooth of the scape wheel twice during each vibration of the balance back and forth.

Witnesses:

THEO. W. FARNSWORTH, }
ARTEMAS BROWN. } PROSPER HUMBERT.

Mr. Horologer said this escapement appeared to be a very ingenious adaptation of the principle of the vibrating cylinder escapement to the detached system. The "arc," *E*, corresponded to the cylinder, with its lips, *d* and *e*, upon which acted the pins or teeth of the escape wheel, to impel the balance alternately in one direction and the other. The detached action was obtained by means of the detent *D*, with its two locking pallets, *f* and *g*, which arrested the escape wheel and held it till it was unlocked at the proper time by the pin, *j*, acting upon the detent point. All of the rubbing parts can, of course, be jeweled, as usual.

But the inquiry suggests itself: Is not the detent just as liable to be jarred out of its resting place, against the pin, *k*, as the detent of the chronometer, and would not the effect of such an accident be just as detrimental? If this accident could be provided against without complicating the escapement, it would certainly seem to be a very simple and effective solution of the problem of a double impulse chronometer. The improvement is not confined to the precise form shown in the patent, but any equivalent form or arrangement may be used which does not change the principle or substance of the invention.

Mr. Horologer said he was very glad to give "honor to whom honor is due," and Mr. Humbert makes out a very fair case of priority of invention. Like many other inventors, that gentleman has thus far reaped only glory for his labors, and it would be too bad to be deprived even of that. As his patent has now expired, anyone can make these escapements who wishes. Doubtless Mr. H. would be well pleased to have them well tried by as many of the trade as desire to do so, asking only that credit be given to him as the inventor, so that at least honor, if not profit, may be his reward. We shall be glad to receive the description of his double impulse improvement on the lever escapement.

WILL A WATCH STAY DEMAGNETIZED?

Secretary of Horological Club:

Can a magnetized watch be thoroughly demagnetized? I have had one demagnetized, but it goes back to a magnetized condition again. P. W.

Mr. Electrode said that a watch may be so treated as to be perfectly freed from any trace of magnetism, but that will not prevent it from becoming magnetized again when exposed to the proper conditions. No matter how often it may be cured, if it is exposed to the action of a magnet it will be magnetized again. The only recourse is to keep it away from magnets and other similar influences. It is the same as we would say that a rifle bullet will wound a man, no matter how often he has been cured of gun-shot wounds before.

Up to this time there has been no way to prevent iron and steel from becoming magnetized when properly exposed to magnetic action. But, very recently, some electrical investigations have been made, which seem to indicate that both iron and steel may be powerfully magnetized in such a way that the magnetism shall be latent in the metal—that is to say, the molecules of the metal will be so disposed, relatively to each other, that their magnetic polarities shall be satisfied or neutralized within the metallic piece itself, and so will exert no attraction repulsion externally. Such pieces would of course have no magnetic action upon each other, any more than if entirely free from magnetism. They would be acted upon by magnets brought near to them, but this action would be temporary only. As soon as the magnets were removed, the pieces would resume their normal external neutrality, and, so far as the ordinary tests indicate, would be non-magnetic. Whether this process can be practically applied to the pinions and other parts of watches in the finished state, he was unprepared to say without further experiments. Thus far it had been applied only to "cast steel." But both the hardening and the tempering, and also the shaping and working of the steel by tools, would be apt to destroy this magnetic condition, so that it would be necessary to apply the process to the finished parts. He thought that this could be done by suitable modifications of the process.

C. J. OLIN'S CENTERING TOOL.



This little tool is made to fit in the taper of the tail stock in all first-class American lathes, and has a fine drill point, hardened so it will start the center on any staff that can be drilled, and is provided with a cap to protect the point when not in use; price, \$1.50. Manufactured by the Ohio Watch Tool Company, Piqua, Ohio.

Mr. Clerkenwell exhibited this little device, which he thought would prove very handy in connection with a well-fitted lathe. The cut shows the construction so clearly that a description of it is needless.

WHAT CAUSES A WATCH TO OVERBANK?

Secretary of Horological Club:

Will some of your honorable body tell me what causes a watch to overbank, and oblige R.

Mr. McFuzee supposed that the question of our correspondent referred to the overbanking of detached lever watches. The primary cause was any defect in the locking or wheel or pallet mechanism, which impelled the lever backward when it should go forward. Even setting the hands backward might do this. The immediate cause was some defect in the banking action proper. Taking the English or patent lever as example, the lever fork might be too short; the banking pin might be bent backward or to one side; it might be so short as to slip under the table roller, instead of falling against its edge; the lever arbor or the balance staff may have too much end shake, so as to produce the same effect; the table roller may be out of true (*i. e.*, not round), so that the banking pin can force its way past it on the scant side; the banking pin may be loose, or may be so weak as to bend or spring back and so let the lever fork pass it, etc. In any case, the lever, instead of being stopped by the table roller and kept on the side where it belongs until the ruby pin comes around into the fork, makes its way past the roller. Consequently, when the ruby pin then comes around, it strikes on the outside of the fork instead of within the notch, and the escapement is blocked. In watches where the banking pin is substituted by a point formed on the solid metal of the lever fork, the same remarks apply, by understanding "point" for "pin." The remedy depends, of course, on the particular defect which exists in each case, and consists in correcting that defect. The modes of correcting all of the defects named are so numerous that it would be hardly practicable to give specific directions in the limits at our disposal. Mr. R. should consult "Excelsior's" series of articles on the detached lever escapement, in "The Practical Hints on Watch Repairing," in back numbers of THE CIRCULAR. Those articles are thoroughly practical, and give the most complete and serviceable treatment of the subject he had ever seen in any work.

Lathes and Lathe Work.

BY THE MODEL WATCHMAKER.

MANY SMALL parts of watches can be readily made in the lathe, although most can be had of the material men; *i. e.*, if the material man is at hand just at the exact instant the part is wanted. Conspicuous among such parts are the hair spring stud and guard piece of the regulator of Swiss watches, and the collet for the hair spring. These parts can be bought cheaper than they can be made; but still, if we make one, we know it is just right, and if we count the time in hunting and fitting one, I am not sure but one made would be the quickest. If you use an American lathe for making a hair spring stud, select a piece of hard brass wire large enough so it will square the size of the stud into which the hair spring pins; and flatten it with a file for about $\frac{1}{8}$ of an inch back on

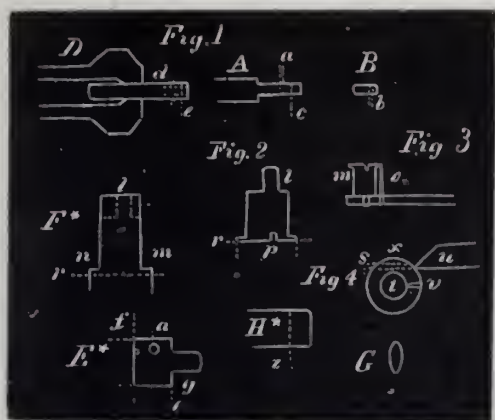

both sides, as shown (magnified) at fig. 1, where *A* shows the wire flattened, and *B* an end view of same. At *a b* are shown the hole drilled for the hair spring. A hole for pinning in a hair spring should be in diameter twice the width of the hair spring. We can now insert our wire in the split chuck, as shown at *D*, and to the exact size to fit the hole in the balance bridge. The dotted line, *c*, shows the position to which the shoulder should be turned. There is some discrimination necessary, if the old stud is gone, about judging the distance the hole for the hair spring should be above the shoulder; but it is better to determine this, and turn the part going into the bridge after the hole is drilled for the hair spring, than before. At diagram *E** is shown, magnified, such a stud, *a* representing the hole into which the hair spring is pinned; *g* the pin or tang which goes into the bridge, and *f* the line where the stud should be cut off. It is well when fitting a stud to a bridge—*i. e.*, the pin going into the bridge, to broach out the hole a trifle, as it has frequently been closed, or otherwise tampered with to make the old stud fit. The guard pin, which turns or buttons over the hair spring, is a piece quite often missing, and one no material dealer carries; and it is one that most watchmakers slight, and still it is important, as frequently watches fail to give good results from imperfections in the regulator pins. A few words on hair springs and regulators can well be said here: Loose pins are a common source of error; look to this. Another pernicious thing is a gummy condition of the hair spring and pins, caused by vicious gummy oil adhering to both pins and hair spring. Many watchmakers, if they see any trace of rust on a hair spring, will smear on plenty of oil, and only remove enough so the coils will not positively adhere together. Indeed I had a case in hand only a short time since. A fine watch, with a Breguet hair spring, would not keep time, and several workmen had tried but with indifferent success. I found, on close examination, that the hair spring (a close-coiled one), was covered with viscid oil; enough, so that if the motion of the pocket caused the coils to touch they would adhere, and continue to do so for an indefinite time, perhaps for only a few beats and might be for minutes; at any rate long enough to cause the watch to perform very unsatisfactorily. The hair spring was affected with rust enough to detract from a correct performance, so I put in a new one. A

large mouth bottle with benzine or sulphuric ether, into which the hair spring is introduced and well shaken, will generally cure the trouble if the hair spring is not rusted—if it is, bounce it out, as a rusty hair spring is always growing worse. By brushing the bridge with benzine or alcohol, giving the curb pins a good share of the operation, will remedy the adhering of the hair spring to the pins. In turning the guard button, which really forms the outer curb pin of the regulator, it is well to leave it so that by turning half way round it will approach nearer to the inner curb pin. This can easily be done when in the lathe; if we select a piece of hard brass wire large enough to make the guard button, we turn it to the form indicated in diagram *F**, then turn the shoulder, *m n*, which represents the head or projection which holds the hair spring in place, as shown in fig. 3, *m* representing the projection. After the wire is turned with the shoulder, as shown at *m n*, diagram *F**, the wire is bent slightly to one side, so that on turning again the pin to go into the regulator would be formed at the dotted lines *l*; this enables us to have a choice in the side we turn toward the fixed pin *o*, fig. 3; and gives us a different space between *o* and *m*. After the wire is turned it is to be flattened on two sides, and cut off at the dotted line *r*, and the slot for the screw-driver, shown at *p*, fig. 2. These guard buttons should be riveted in the regulator bar, but never screwed in. To make a nice hair spring collet is by no means a difficult job, still we see but few real nice hair spring collets. Select a piece of brass wire large enough for your collet, and put it into your lathe, and drill a hole a trifle smaller than your staff at the end and in the center of your brass wire; an end view of the wire is shown in fig. 4, magnified. After the hole *l* for the staff is drilled, a fish belly graver should be used to cut a start for the drill. There is a good deal of judgment necessary in drilling the hole for the hair spring to be pinned into; the hole for the hair spring should come as near the hole *l* as possible; and the diameter of the collet should never be greater than absolutely necessary. The dotted line *s* indicates the position and direction of the hair spring hole; the hole for the hair spring in the collet should be once and one-half the width of the hair spring in diameter, and the thickness of the brass at *x*, above the pin, with which the hair spring is pinned in, should be fully $\frac{3}{4}$ the diameter of the pin hole. The collet should be of the very hardest and best brass. The hole at *l* should fit tight on the part of the staff on which the collet goes, so that when the collet is split at *v* with a screw head file, it will clasp the staff with friction ample to hold the collet in place. In drilling the hole for the hair spring, the drill should be started at the cut made with the graver, and as soon as you can see the drill begin to swell out the brass to come through, discontinue the drilling and open the hole up with the graver; for, if you urged the drill forward, as it came through on the oblique surface it would stand a great chance to break off the point. After the hole is drilled it should be broached a little taper to fit the pin, and should now be restored to the lathe and cut off, as shown at the dotted line *z*, diagram *H**. A hair spring collet should be perfectly true, and the position it occupies on the staff should be such that it can be turned around on the staff to take up or let out the spring, and not disturb the truth of the spring in the flat; for if changing the position of the spring alters the truth of a spring, either in the flat or round, the collet is a bad one, or the seat or place on the staff is wrong.

Advice to Watchmakers' Apprentices.

BY A MAN WHO HAS SPENT TWENTY YEARS AT THE BENCH.

OWING TO THE variation in the size of brick it is impossible to give exact sizes; but in the accompanying cuts we will give sizes of frame work, and let the brick, as the saying is, take care of themselves. It really makes but little difference whether the furnace

is 8 or $8\frac{1}{2}$ inches square, which is about the difference in the lengths of brick. The furnace, in all essential features, is the same as in last number, except it is set up on a frame work, and depends for the air to supply combustion on the rotary fan bellows below the brick work, and in having a stove pipe to carry off the vapor and smoke. It is an essential matter to have the vapor from the chemical substances used in melting carried off, and not let escape in the room. The prominent features of this arrangement are cheapness and simplicity, and if anything like well made will be found thoroughly effective. A furnace of the size described will melt 50 ozs. of silver or gold in 20 minutes, and everything but the furnace part will stand all the ordinary service of a shop for years. Fig. 1,

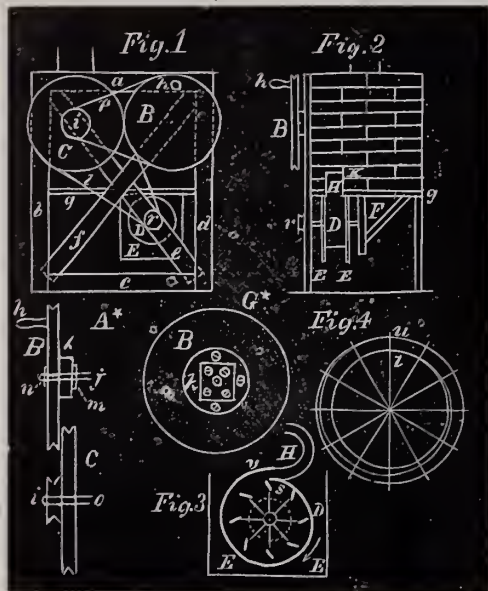

in the cut, represents a side view of such a melting furnace; the scale used is $\frac{1}{3\frac{1}{2}}$ of an inch to 1 inch. The pieces *a, b, c, d*, are of inch stuff, 3 inches wide; pine is as good as anything; the corners are halved together and secured by 2 one inch wood screws at each corner. The diagonal pieces *e, f*, are tenoned in, as shown at the dotted lines at the corners. The floor on which the brick rests is shown at *g*. The upright pins *d, b*, are 36 inches long, and the horizontal pieces *a, c*, 30 inches long. Two wheels made of inch board and 15 inches in diameter are shown at *B, C*; these wheels have grooves in their edges, as shown at diagram *A**. These wheels turn on smooth iron pins fixed in the diagonal pieces *e, f*, as shown. These wheels are very simply made; the wheel *B* has a round piece 4 inches in diameter glued and screwed on the back at *k*; this serves to stiffen it and keep it out from the frame work shown in fig. 1. At diagram *G** is shown (slightly enlarged), the wheel *B* and piece *k*, and also a plate of metal attached to *k* with 4 screws. These metal plates are for bearings to turn on the smooth iron pins *j, o*, and should be of brass or iron at least $\frac{1}{8}$ of an inch thick. Some care should be used in fitting and securing the plates on these wheels so as to make the wheels run flat and true. The outer ends of the pins can be drilled and a pin of wire inserted to prevent the wheel from coming off; and an iron washer, such as is used on carriage bolts, can go between *k* and the diagonal piece *f*. A crank pin shown at *h* serves to turn the wheel *B*. The wheel *B* has a round leather band (like a sewing machine band) running to the pulley *i* on the wheel *C*. The wheel *C* turns on a smooth iron pin exactly as the wheel *B*, and carries a band *l*, which drives the pulley *r* on the arbor of the rotary fan *D*. Now as the wheel *B* is 15 inches in diameter and the pulley *i* 3 inches in diameter, the wheel *C* must make 5 revolutions to *B*'s one; and *C* being again 15 inches in diameter and driving the pulley *r*, which is 2 inches in diameter, *D* must turn $7\frac{1}{2}$ times for *C*'s once; hence we have $5 \times 7\frac{1}{2} = 37\frac{1}{2}$ as the relative speed of *B* to *D*. Consequently if the fan wheel *D* is 8 inches in diameter we will get a current of air moving with a velocity of over 30 feet a second, if the wheel *B* is turned twice in that time. This arrangement will give an ample supply of air, as in

this case we get a greater volume of air than with the bellows, but it is not thrown into the furnace with as much force. The diagonal pieces *e, f*, should have an extra thickness of board glued or screwed on at the places where the pins *j* and *o* (on which the wheels *B* and *C* turn) are inserted, to support and stiffen them and prevent their working loose with the jar. The rotary fan is very simple in construction and is best made of $\frac{3}{8}$ poplar boards, such as carriage makers use. On making this part take two pieces of such $\frac{3}{8}$ board, 10 inches wide and 13 long, and sweep a circle 8 inches in diameter; next sweep one $\frac{1}{8}$ of an inch farther out; next set your compasses one inch wider and sweep the circle shown at *u*, fig. 4, the first two circles being shown at *t*. Another circle should be swept $\frac{1}{8}$ of an inch larger than *u*. These two sets of circles are shown in fig. 4. We now divide the outer circle into twelve parts by spacing around with the dividers set to sweep the circle, which will just make 6 divisions; halve these and we have twelve spaces. It will be seen on inspection of fig. 3, that the curve *D*, representing the wooden drum in which the fan wheel works, is not a true circle but a spiral; commencing at *s*, just clearing the wings of the fan wheel and when the complete circle is made at *v*, it is one inch away. Now, in laying out this curve, if we start on the circle *t* at *s*, and we add $\frac{1}{2}$ of an inch as we get at each of the radial lines, shown in fig. 4; when we get around to *v* we will be 1 inch away, and establish the spiral form of the drum *d*. The object of this form of the drum *D* is to get a current of air, by means of the fan wheel, out of the pipe *H*. There is inserted into the grooves, cut in the two boards *E E*, fig. 2, thin boards ($\frac{1}{8}$ of an inch), forming the drum *D*; the grain of the wood in the thin pieces run parallel with the axis of the arbor of the fan wheel. There should be 6 wire bolts passing from side to side to hold the boards *E E* together. There are two holes (one in each of *E*), around the spindle *r* of the fan wheel, 4 inches in diameter, to admit of ingress of air. It will be seen on inspection of fig. 3, that as the casing of the drum *D* gradually falls away that the centrifugal force of the air put in motion by the fan wheel will fill the space between the fan wheel and *D*, and finally be forced out of the spout *H* to supply the furnace. The fans on the fan wheel should not stand at radial lines, but inclined as shown. The exact size of all the parts is not necessary, except to say that the length of the fans in the fan wheel should be 3 inches, and width $1\frac{1}{2}$ inches. The manner of introducing the pipe *H* into the furnace, as well as the method of supporting the piece *F*, fig. 2, will naturally suggest themselves. Of course it will be understood that the entrance to the furnace, shown at *K*, will be closed. The pipe (in fact, stove pipe), for carrying off the gas and vapor, should be 6 or 7 inches in diameter. It may seem trifling to some parties that so much space should be devoted to a melting furnace, but every experienced worker of gold knows that to get a tough, fine alloy of good color, that too much pains cannot be taken in the furnace. And the boy who has to *pestle* for a broken crucible will join in for any arrangement for preventing such disasters. In our next article we will give some directions for molding and casting articles of gold and silver. The best material for the pipe *H* is tin, and any tinsmith will soon fix that part for you. It should have been stated above that metal plates should be on both sides of the wheels *B* and *C*. These metal plates should be put on so as to cause the wheels to run true and flat, and as they (the plates) are quite thick they will stand a good deal of service.

Problems in the Detached Lever Escapement.

BY DETENT.

WE WILL NOW give the details for making the model for a ratchet tooth lever escapement. As suggested in a former article it is by no means a settled fact that we have yet arrived at the best or most perfect form of lever escapement, there are so many factors involved, not only in the principles combined, but also in

contingencies which modify the combinations. But with such a model as is here described, we cannot only study the principles but the modifying contingencies. In making a model we will begin with the scape wheel, which should be made of No. 14 (American gauge) hard brass, and 5 inches in diameter. In the accompanying cut the wheel is shown one-half this size—that is, 2½ inches. As noticed in our opening article of this series, we take the radius of the scape wheel as the base of all our calculations. As I presume all my readers know, the radius of any circle is equal to 60°, and as a circle contains 360°, 60° is, therefore, equal to one-sixth of the entire circumference of the circle. To prove this, take a fine pointed pair of dividers or compasses, and sweep a circle, and carefully space around on the line, and just six spaces will encompass the circle. Consequently, if we sweep a portion of a circle containing more than 60°—to illustrate, we set our dividers to 1¼ inches; of course this will sweep a circle 2½ inches in diameter. In this case we sweep the circle *a a a*, in which stands the extreme point of the scape wheel teeth. We take the dividers while still set, set one point at *b* (we take this point to economize space), and sweep the short circle *a¹ a²*. If we now set one point of the dividers at the dot *a¹*, the other point would prick our circle at *a²*. This would establish an

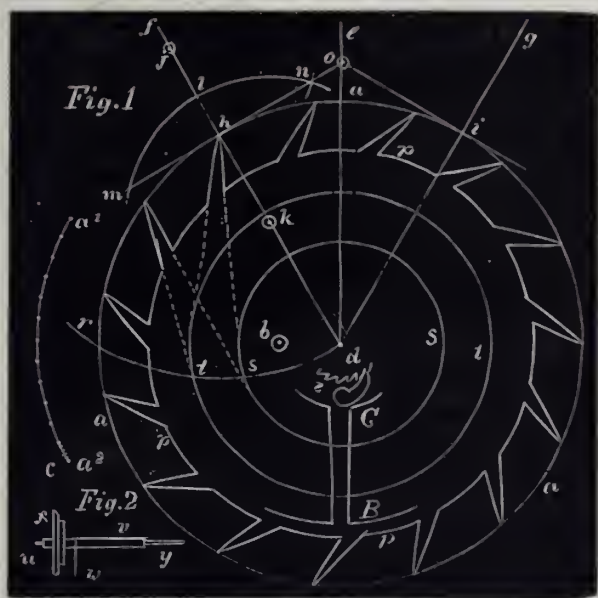

arc of 60°. If we divide this arc into 12 spaces as shown, each of these spaces will represent 5°. We now divide one of the spaces into 5 parts, as shown at *c*, and we have a measure of degrees on our circle. The reader, of course, will understand that in laying out his scape wheel he will proceed in the same way, except he takes double the space (2½ inches) in his dividers. But the idea the learner should impress upon himself is, to keep these relative proportions, no matter what the size, and learn to judge of the relative size of one part to another. We have now established the outline of our scape wheel, and laid out an arc of 60°, and divided one portion into degrees, so we have a measure to go by. We now take in our dividers half of the arc *a¹ a²*, which is equal to 30°, and establish on the circle *a a a*, the points *h i*, from the center *d*; through the points *h i* we rule the lines *f d* and *g d*. The arc contained between *h i* is the one embraced by the pallet action, and is equal to the radius of the scape wheel. It may not be amiss to explain why we laid out the arc *a¹ a²*, and divided it into degrees. In answer we would say, we wish to reduce these problems to the simplest condition possible—using the radius of the scape wheel as the base of all our calculations, and reduce our drawing instruments to the fewest possible: a pair of compasses, a rule or straight edge, and a point which will scratch the surface of our sheet brass; for we are supposed to be laying-out our scape wheel on our No. 14 brass. We retain the measure of degrees because we can always obtain them from the radius; and, beside, it is a common mode of expressing or discrediting portions of a circle. To establish the position of our pallet staff we must raise perpendicular lines to the lines *f d* and *g d*. Adher-

ing to our idea of ignoring all drawing instruments but those mentioned, we will get our right angle at *h i* geometrically. Take any convenient space in your dividers, say the distance *h j*; make a prick mark at *j*, and also at *k*, on the line *f d*; open your dividers, say, so as to span from *k* to *l*, and sweep the curve *m l n*. Change the divider's point, which rested at *k*, to *j*, and sweep the short intersecting lines at *m n*; next rule the straight line *m n*, continuing it until it crosses the line *e d*. Repeat the operation just described on the line *g d*, and where these lines cross each other at *o*, is the position of the pallet staff. We will now let all consideration of the pallet action rest, as we have a constant measure of our scape wheel, and can at any time get the angles and measure of our pallets, because we have the diameter of our scape wheel known. Here, again, we would call attention to the advantage of the system we have adopted in these problems: no matter what the size of our scape wheel, whether it is 5 inches or ¼ of an inch, half of the diameter is the radius, and here we have the measure of the other parts. All we want is accurate measuring tools and this part of our problem is solved. We will resume our scape wheel. We take in our dividers four of our spaces of the arc *a¹ a²*, and add four of the degree spaces, and it will just divide our circle *a a a*, into 15 equal parts. We commence by setting the dividers on the point where the line *f d* crosses the circle *a a*. We next take one-half of the space of one tooth or, for convenience, 7° from the arc *a¹ a²*, and set off from the circle *a a a*, on the line *d e*, and strike the circle *p p p*, which represents the length of the teeth in the scape wheel. The face angle of the ratchet tooth wheel is generally made at an angle of 24°, so as to present a sharp angle for action on the pallets. To establish this angle we sweep the circle *r d* (using the radius *a d* in the dividers), and *h* as a center, and lay off on this circle 24° (which equals the space of one tooth), from the center *d*; while the dividers are set we sweep the circle *s s*. We draw the line *h s*, and we have the inner face of the tooth at *h*, indicated. By carrying the process around the circle *s s*, we can establish all the front faces of the scape wheel teeth. To get the angle at the back of the teeth, we extend the arc on the circle *r d*, from *s* to *t*, 12° (one-half the space of a tooth), and sweep the circle *t*; lines drawn from this circle, as shown, defines the back of the teeth. The form of the arms, 4 in number, is shown at *B*; and immediately above it is shown the click and ratchet, as the scape wheel is mounted directly on the driving arbor. At fig. 2 is shown a diminished side elevation of arbor. The arbor should be of Stubbs' steel wire, ¼ of an inch in diameter and 4 inches in entire length. It should be gotten up neatly and quite true, so the weight will have a constant action. If the ends *x y* are turned in a back rest the part *v*, used as a spool, will be true enough. The part at *x* shows the ratchet, which will need no description as it is exactly like the ordinary weight clock. The pivot at *y* should be squared for a key, or a permanent short crank attached to wind it up; this pivot should pass through the board on which the model is mounted (and shown in the September number of this journal), so it can be wound without disturbing the balance, or the cord can be arranged to wind by pulling up, as in some of the old-fashioned weight clocks; a weight of 2 to 4 ounces will be quite enough. The cord is best made of that fine line used for fishing, and generally sold as sea grass. Such an escapement model could easily be made to run with a spring, or a train of one or two wheels could be added, so the model would run for several hours; but the weight is preferable, as it enables us to judge better of the relative effects of any change we should make in pallet or roller action. The center portion of the scape wheel is 1¼ inches in diameter, and has four arms, one of which is shown at *B*. Such a scape wheel is readily sawed out with a jeweler's saw after it is laid out. To endeavor to cut such a wheel with cutters in a cutting engine would be unnecessary, as if carefully laid out and filed up it will be quite accurate enough. The ratchet *z* should be about ¾ of an inch in diameter. A click and click spring finishes the scape wheel. In our next we will give the manner of laying out the pallets in the regular form, and give a method

of making the pallets adjustable, so as to study any changes in angles, etc. I would like to call the attention of such workmen as are careful observers to a condition frequently to be seen in the pallets of English lever watches, which have been running for a number of years: and this is the formation of a pit in the face of the pallet from $\frac{1}{4}$ to $\frac{1}{3}$ of the way down the face of the pallet where the tooth of the scape wheel strikes the jewel. What does this mean? It certainly does not say the tooth follows the locking face down to the impulse angle; and then constantly pressing the jewel, commencing at the exact instant the tooth is unlocked, to impart an impulse to the pallet, but it rather says the train is tardy, but finally gets the scape wheel in motion and catches up with the pallet after an appreciable interval.

German Watch and Clock Makers.

THE OLD church at Lübeck is considered to contain one of the most ingenious specimens of early clockwork that has been preserved. It represents the changes of the heavenly bodies until the year 1875, and when it strikes twelve, a number of automaton figures are set in motion; the electors of Germany enter from a small side door, and perform the ceremony of inaugurating the Emperor, who is seated upon a throne in front. Another door is opened, and Christ appears, when, after receiving His benediction, the whole cavalcade disappears midst a flourish of trumpets by a choir of angels. On each side are bas-reliefs illustrative of passages in the life of our Saviour. In that of the Last Supper a mouse is seen peeping from beneath the white table cloth, and this animal represents the armorial bearings of the once puissant city of Lübeck.

The English and the Augsburgians became famous for their clocks and watches, and made many of the latter, as well as clocks, which showed the hours, phases of the moon, and the days of the month. At Augsburg were also constructed most of the clocks and watches with moving figures, such as a moon, a monkey blowing a trumpet, and similar toys moved by clockwork concealed within them. These toys were chiefly made and used for presents from the ambassadors of Christian countries to Oriental princes and barbarians. It is stated that a miniature silver army of cavalry and infantry was made at Nuremberg, which moved their limbs, went through their exercises and fired, by clockwork within them. In the cities of Augsburg, Nuremberg and Ulm, clock and watchmakers were obliged to observe certain ordinances; and also, as a proof of their skill and ability for a masterpiece, to make a horizontal square or hexagonal table clock; masters' sons were free to choose which, and eight months' time was given them to complete the work. The artists of Augsburg and Nuremberg used to take their clocks and watches in great numbers to the fair at Leipzig, and thus they were spread abroad over Europe. Nicholas Rugendas was a celebrated clock-maker of Augsburg in the fifteenth century.—*Ext. of Correspond.*

Ornamenting Glass, China, Etc.

AN IMPROVED method of ornamenting glass, china, tiles, metal, etc., by copying and multiplying works of art, has been patented in this country by Mr. R. E. Frank, the process being a communication from L. Micciullo, of Rossano, Italy. The surface to be ornamented is covered with a sensitive varnish, and the picture, pattern, or design, being made transparent, is laid on the varnish, and the light allowed to act on the sensitive film through the picture. After sufficient exposure the picture is removed, and colors are applied in the following manner: The finely pulverized colors or enamels are taken up (in a dry state) by a brush, applied to the parts where they are required, which can be clearly distinguished in the layer of varnish on the article to be ornamented. The colors, enamels, or

metallic oxides adhere more or less according to the degree to which the adhesiveness of the varnish has been affected; that is to say, according to lights and shades in the picture, design, etc., to be reproduced, or according to whether the varnish has hardened more or less. The varnish may be composed of yellow gelatine, gum tragacanth, and quince seeds mixed with rain water, and chrome salts, such as bichromate of potash, added to sensitise it. The composition of the varnish may greatly vary, and has to be adapted to the weather, the state of the atmosphere, and similar conditions; for normal conditions, it may be made by mixing the said ingredients in the following proportions:

Filtered water.....	500 parts.
Gelatine	1 part.
Gum tragacanth.....	10 parts.
Quince seeds.....	3 parts.
Chrome salt (in crystals).....	40 parts.

If the atmosphere is very dry, the quince seeds may be replaced by sugar, glucose, or honey; or these latter substances may be used in addition. As a substitute for gum tragacanth, gum arabic may be used in the proportion of, say, thirteen parts. It may here be repeated that these proportions are merely approximate, as no absolute rule can be laid down as to the exact preparation of the varnish, which will have to be varied as directed by experience according to the conditions of the light, the degree of dryness of the air, and other conditions; but practice will readily suggest what is requisite to those skilled in kindred processes. When the oxides have been applied, they are protected by a coat of thick turpentine, such as is known in France as "terebenthine grasse," attenuated, if required, by common turpentine, and the other superfluous parts of the varnish removed by immersion for twenty-four hours (more or less) in water acidulated with vinegar or other acid, say pure acetic acid, or hydrochloric acid. The strength of the bath (viz., the proportion of acid therein), may be varied within reasonable limits, and determines the length of time which the immersion has to last. The more acid in the bath, the shorter the immersion; the weaker the bath, the longer the immersion has to be. The object under treatment is then dried, touched up, and further colored with metallic oxides, if desired, and fired in a kiln. Copies of works of art and the like, such as portraits on glass (whether seen by transparency or by reflection), and either fired or not, whether they are drawn from nature, or a copy of photographs, or of other design, are with advantage produced by making two or more *fac simile* copies as above described, the copies being exactly fitted one over the other. Two copies, whereof one at least is transparent, are sufficient in most cases. Upon one of these the enamels, metallic oxides or other suitable colors may be applied, or it may be touched up after the colors are fired; the second copy is placed over the colored one, so that all details and contours register exactly in both pictures, and consequently appear as a single image to the eye. The two copies are united either by joints, by leads or framing, or they may be cemented together, or especially, if a glass, fired with a flux applied at the edges, so that the two, being fused together, form a single piece; this may also, when practicable, be effected by the firing which fixes the colors. The manner of uniting the plates by the interposition and fusion of a flux is the one which is preferable. Where a simple ornament, mental design, or ornamental surface without figures, etc., is desired, it can be obtained upon glass and other articles by applying a varnish composed of asphaltum, pitch, or an equivalent material, dissolved in spirits of turpentine, to which sulphuric ether is added. The plate is then dried, and the design applied, the plate, etc., is then treated with fluoric acid and water, mixed in suitable proportions, then washed in water, and the varnish removed, as will be readily understood. This manner of proceeding produces plates, etc., which have a "frosted" or "crackled" appearance, that is to say, they appear as if covered by numerous vein-like grooves or marks. The varnish for this purpose may consist of:

Asphaltum.....	100 parts.
Spirits of turpentine.....	50 parts.
Sulphuric ether.....	50 parts.

These proportions may, however, vary considerably, and according to their variation will produce a different design. The sulphuric ether may be replaced by light naphtha or by benzoline. The component parts of the varnish do not enter into chemical combination, but merely become mechanically mixed. The mixture is applied to the article by means of a brush or a pad similarly to "stippling." By this means the non-volatile fatty component parts of the varnish adhere in flakes or patches to the article and protect it, and the fluoric acid attacks only the parts not so protected, and thereby the design is produced.

How to Make and Engrave Silver Bangles.

BY EXPERT.

OF COURSE the great staple of silver bangles are monograms, and the writer cannot too firmly impress on the reader to avoid sameness. I mean by this making your letters all alike or nearly alike—having one stereotype form of letter and using it on all possible and impossible occasions. Another fault is combining letters so they can be read either way as, say, J. L. or L. J; this, in monograms, is a good deal like the fellow's combined dressing comb and butter knife. Pleasantry aside, the letters combined in a monogram should be as distinct and as easily made out as if arranged in their proper order: If the initials are G. E. S., the letter S should be the conspicuous letter, both in size and ornamentation; and if in cypher the letters should follow one another in order. In my last article I made mention of borders; it is a good plan to sweep, say, 9 circles of the exact size of a ten cent piece, and carefully lay out a different border on each one. I say lay out, for by this I mean make the spacing exactly even, as in fig. 2, where the dotted lines are ruled from spacing on a large circle. To retrace a few lines, I said, lay out 9 circles, as shown in fig. 1, of the exact size of dimes, and on

good idea of the proportion, size considered, is given in the cut. The transferring from the plate at fig. 1 to the dime is effected by rubbing on the face of the design to be copied, a composition of 2 parts of white wax, 1/2 part Canada balsam, 1/2 part olive oil; these to be well mixed by melting and stirring, and left melted for an hour. This composition can be varied a little for the season of the year. A very good material for making transfers with is a preparation for the skin which all druggists keep, called camphor ice and glycerine—yellow rosin soap is also good. There is some little skill and tact needed to get a good impression and transfer; the method to be pursued is to engrave one sample of, say, a letter, and smear the composition given above over the face of the letter, rubbing it with the finger to fill the lines perfectly; the surface of the engraved plate must not be rubbed off too much, but left so as to show a strong, full smear over the entire surface. Now lay a thick, heavy, smooth surface paper over the letter or object you wish to copy, and with a piece of pegwood, whittled as shown in fig. 5, where C is a section on the dotted line b, rub the back of the paper over the letter with the curved edge of the pegwood, so as to press the paper into the engraved lines; on taking off the paper a perfect copy of every line will be in reverse on the paper. Now lay this paper on a polished surface, and with the tip of the finger rub lightly over the back; indeed, the rubbing can hardly be done too lightly; and a perfect copy of the engraved lines will be made on the polished surface. A little practice will soon enable you to succeed. A pair of scissors should be used to cut the paper round or a little more than half round. We will illustrate: Say we wish to copy the border at fig. 2—the outer line c is just the size of a dime—we put the paper over the cut (fig. 2), and rub with fig. 5, as directed (of course the lines are all filled with the composition as described); the paper is now removed, and it should be cut with a keen pair of scissors to the shape shown in fig. 6, the outer edge corresponding to c c, fig. 2. Now lay the paper (face down) on the bangle you wish to put a border on, guiding by the outer edge of the paper, and lightly rub it, and you will have a perfect copy of your border transferred to your dime, and a minute or two will engrave it. The method of cutting should be to cut the three broken circles, as shown at d, completely around the dime, then add the radial connection as shown at e. The lines forming the pattern can be cut either smooth or by rocking the graver, *wriggling*, as it is termed. This same pattern can be varied, as shown, but it must be remembered that the white lines in the cut represents lines and incisions to be cut in the metal. To make this more plain we will make the pattern in straight lines at H and K. The first example at H, as shown in the cut, are white lines; now in the bangle these would be cut into the metal, and it filled with soft enamel, would be black lines on the white silver ground; while the pattern shown at K would be white silver walls of Troy on a black enamel background. To engrave these lines it is well to cut all the lines in one direction at the same time, i. e., one after the other; I use the straight lines to illustrate, but in cutting the curved ones the same rule applies; cut the lines p n o, then the short ones k l m, and the border is done. In the style K the continuous lines f g are cut first; then the lines in the same direction designated at r s; now if the short lines n i are added the pattern is complete. The great beauty of this design is its regularity, and as we can make it mathematically correct in our first specimen, and of course we get mathematically correct transfers, and a little care will give our work the appearance of extreme perfection. The worm fence pattern in 4 is very cheap and simple, and still looks well; the heavy line is done wriggled with a flat bottom graver, and the little spring in the angles is done with a polished round bottom graver, shaped as shown at M; this bright cutting shows in fine contrast to a wriggled line. If any of the work is filled with soft enamel it should be done before the final finish is given. We will say we wish to fill or soft enamel (enamel sounds better than fill) a portion of a bangle; we engrave this part (to be filled) first before it is taken out of the holder. After the engraving—that is the part to be filled—is done,

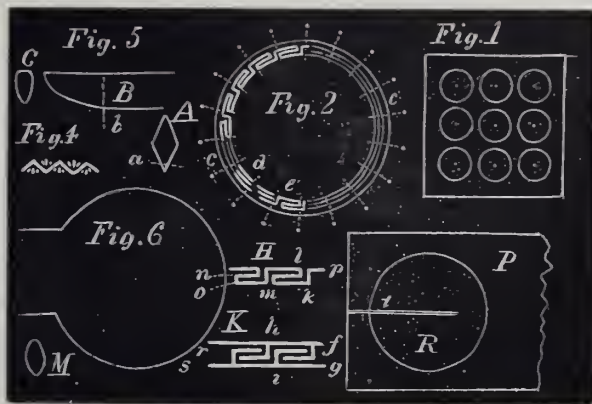

these engrave very carefully 9 different styles of borders. I give three styles in the accompanying cut, and will give others along as these articles progress. As will be seen, fig. 2 is larger than a dime, to make the method plainer, but in executing them make them dime size and perfect in form and spacing for transferring; for if they had to be laid out on each individual dime it would take more time than the job would be worth after it was done. Lay out the 9 borders as shown at the circles in fig. 1, and engrave them: you can commence with only a few—3 or 4—adding others as you need them. After they are engraved take a transfer copy of the border you desire and transfer it to the dime in hand, and engrave it before the monogram. The bars of the zig-zag lines or walls of Troy pattern should be cut with a flat bottom graver, i. e., a lozenge graver, with the lower angle flattened, as shown in the cross-section diagram of a graver at A, the dotted line indicating the flattening, by whetting off the lower angle. In this case the width of the flat should be slight; enough however to give an idea of solidity to the pattern: a

remove it from the holder, and boil off the cement with alcohol; a stiff brush with alcohol will remove the little cement remaining from the kind of holder recommended in these papers. A holder for filling should be made of heavy sheet brass countersunk, as described in former article, but no cement should be used. Such a holder is shown at *P*; *R* representing the countersink; at *t* is a slot sawn to make the holder elastic, so that a dime inserted in *R* the spring of the metal will hold it firm enough for the filling. Insert the dime in the recess at *R*, and heat the holder and dime over your lamp or gas jet until the ordinary black lathe wax, made of shellac and ultramarine blue—5 ounces of wax to 1 ounce of ultramarine blue—will melt if a stick of the cement is rubbed over it; a wooden knife made of boxwood will scrape off the wax after a little practice, and not scratch the silver. A cloth moistened with alcohol will remove any little trace of wax from the polished surface, and generally a few strokes of a clean new black buff will restore the surface perfectly, leaving the filled lines with a polished surface. If, by any cause, the surface of the dime should become depolished, the rotten stone buff and oil will fix it so that after washing and buffing with a black buff the brilliancy will be perfectly restored. The bright engraving is now added. It is well to avoid washing bright silver with soap and water, as it detracts from the polish.

Practical Treatise on the Adjustment of a Four-Jewel Cylinder Watch.

[First-Prize Essay by HERMANN HORMANN.]

Continued from Page 248.

IF THE SMALL screws of the cap draw well it is only necessary to shorten them with a screw shortening tool, if they should protrude, and to round them off below, so that the thread in the brass be not damaged by the sharp edges. By rounding the screw ends it happens at times (especially with small screws), that the last turn of the thread is pressed down, and this causes often undesirable injury to the next thread; it is commendable, therefore, after rounding, to pass a knife blade gently in the screw thread, while revolving the screw. The thread is quickly restored again in this manner. Unserviceable screws are to be cast aside and other ones put in.

56. The greatest attention, however, is to be paid to the effectiveness of the clickwork itself. Before everything else, it is necessary

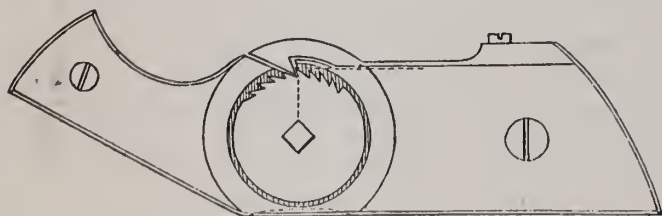

FIG. 4.

that the ratchet wheel teeth are sufficiently strong, that they may offer due resistance to the power of the mainspring after having been wound; again, they must be sufficiently deep and somewhat filed under. If this is not the case assistance is rendered with a good ratchet wheel or three-cornered file.

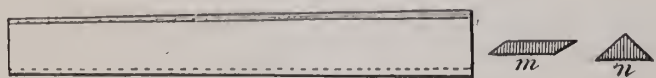

FIG. 5.

The ratchet wheel file, which is better suited to the purpose than a three-cornered one, is of the shape as shown in the cut; *m* shows the cross cut; *n*, however, that of a three-cornered file; the former one has a cut only on three sides, one of its broad sides is smooth.

57. The click must fill the space between two teeth completely, and reach down to the bottom of the tooth; again, the operative part must lie flat against the tooth.

If the click does not reach down to the ground, the defect is improved by carefully filing from the side of the bridge, whereby the click spring is brought nearer to the wheel; provided that it be of the correct shape and position.

The click spring is frequently too long, wherefore the click gears in above the only correct place. If the defect is more pronounced it must be corrected, and it is necessary to set the click spring somewhat back, whereby the holes for the screws and foot pin on the side of the bridge are closed, and others are drilled on a suitable place.

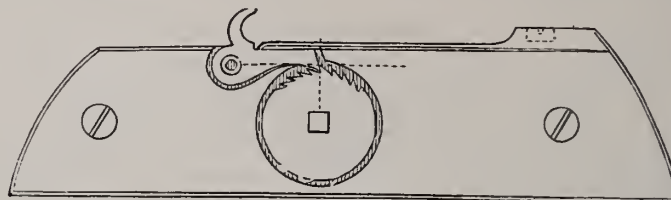

FIG. 6.

58. By the clickwork with loose ratchet wheel, such as it occurs in watches with double barrel bridge or three-quarter plate, the click must have the correct length, so that the tooth braces in right angle and fills the tooth space down to the bottom. If this is not the case, and the repairer is not able to remedy the fault by inserting a new wheel, he is forced to cut away sufficiently with a sharp graver until the click braces corrected; or else he must replace it with a better shaped one. He must pay strict attention that the click cannot slip past the ratchet wheel above or below, and this can often be improved by means of the screw of the former. In fact, it is easy, by this kind of construction, to replace a damaged ratchet wheel by a new one.

59. Too thick and strong a click spring operates with an injurious effect upon a clickwork. In order to weaken them they are left screwed to the bridge, which is wrapped around with paper and fastened in the vise, and filed correspondingly thinner, by holding their head between the fingers of the left hand. The cross stroke, produced by the file, and which favor the bursting of the spring, are removed by means of a file with finer cut, or by grinding lengthways.

60. It must in no case be permitted that the operative part (the click) is soft; it must be subjected to a regular test to ascertain its hardness before mounting it, and in case that it can be filed easily, it is to be hardened. A click spring is best hardened in oil, annealing the actual spring gray blue, the click brown.

61. The polishing of the spring is advantageously done by means of the well known flat polisher, upon which the spring is cemented and ground upon glass, after which it is polished with diamantine. The edges must previously be ground with an iron grinding file and oilstone, and then be rounded off with a small composition file and rouge or diamantine.

62. To produce a handsome polish, frequently possessed by click springs in new watches, is a very toilsome piece of work, occasioning much trouble and loss of time for the repairer who is not skilled in this kind of work. A good grinding, consequently, produced with a few strokes, is of a handsomer appearance than a mediocre polish.

63. In order to produce the mat grinding the oilstone powder is made into a paste, and grinding is continued only as long as the oilstone does not color black. If the repairer desires to obtain a handsome emery grinding, let him draw the click spring rapidly to and fro several times upon a fine flat emery stone.

(To be continued.)

STEP IN THE RIGHT DIRECTION.—The German Reichstag has a bill under consideration to forbid the hawking of watches.

Foreign Gossip.

DEFECTIVE VISION.—In the course of a lecture at Berne by Prof. Pflüger, he stated that in some schools in Germany 70 and 80 per cent. of the scholars were suffering from defective vision, while in the Heidelberg gymnasium the percentage was 100—that is, every lad in the school was afflicted with bad eyesight.

THE DESERT SAHARA.—M. de Lesseps, in a recent lecture on the feasibility of filling the Desert of Sahara with water from the Red Sea, said that the evaporating power of the sun is less there than in the Red Sea, and he does not anticipate that the water will dry up. The cost of the necessary works has now been estimated at 150,000,000 francs, and the time required at five years. All the projectors require is the concession of the lands which will form the shores of the lake.

PRIZES TO BE COMPETED FOR.—Among other prizes recently offered in Germany, we note one of \$750 by the Munich University for the best history of the German woodcarving art from the oldest to the most recent times. A family paper in Berlin has offered five prizes, amounting to \$75, for paintings on porcelain, majolica, and the like, with a view to the cultivation of good taste and opening up a new branch of industry for the women of Germany, Austria and Switzerland.

GOLD IN AUSTRALIA.—The production of gold in Australia seems to have diminished considerably since 1875, when the mines yielded 1,068,418 ounces. In 1876 the quantity sank below one million ounces, or, in exact figures, 963,760 ounces. In 1877 the figure fell to 809,653 ounces; in 1878 to 758,040 ounces, while in 1879 it slightly rose to 758,947 ounces. The year 1880 continued to show a slight improvement, for the yield rose to 839,121 ounces, and 1881 ended with 858,146 ounces.

NEW PROCESS FOR SILVERING MIRRORS.—Prof. Palmieri, it is said, has devised a process for silvering glass by means of the reducing action of glycerine on the salts of silver, which is said to have the advantage of producing a very brilliant metallic deposit. When into an ammoniacal solution of silver is poured, first, a little caustic potash, and then a few drops of glycerine, the reduction begins at once; and this action is accelerated if ether or alcohol be added to the mixture. A moderate heat and darkness are said to increase the brilliancy of the precipitate, and darkness also favors the adhesion of the deposit to the mirror.

NEW THEORY FOR DIAMONDS.—M. Berthelot, in the *Journal de Pharmacie et Chimie* for March, states that from peculiar physical relations he is led to suspect that the true element carbon is unknown, and that diamond and graphite are substances of a different order. Elementary carbon ought to be gaseous at the ordinary temperature, and the various kinds of carbon which occur in nature are in reality polymerized products of the true element carbon. It is thought that spectrum analysis confirms this view; and it is supposed the second spectrum seen in a Geissler tube belongs to gaseous carbon. This spectrum, which has been recognized along with that of hydrogen in the light of the tails of comets, indicates a carbide, probably acetylene.

MICA MASKS AND SPECTACLES.—Herr Raphael, of Breslau, has patented mica masks and spectacles in Germany. One special merit is their great lightness. By a subsequent improvement it is possible for any workman to insert a new piece of mica in the spectacle frame when required, the pieces costing only about three cents. The frame may thus be used for a long time. The workman gets quite accustomed to these spectacles after a day's use. Herr Raphael further provides gray and blue mica glasses, which are quite transparent, and the color of which is fire-proof. They are very pleasant for workmen at large fires, as they prevent strain of the eye. Masks for half of the face weigh only 40 grams (less than 1½ ounces). Herr Raphael also supplies masks to cover the whole face, and, if necessary, also the neck.

EXCELLENT PROVISION.—There is in Germany a society for the welfare of youth on leaving school, and this, along with another society, has recently announced a prize competition having for its subject, "The Choice of an Industrial Calling." The prize is about \$375. Competing memoirs must be confined to the manual occupations and small industries, and should deal with the following questions: What are the peculiarities of such industries (indicating briefly the kind of work involved in various manual occupations)? 2. What bodily and mental capabilities are assumed on the part of the apprentice? 3. What ways are open to an all-round qualification for the particular industry, and what means thereto are required? 4. What material prospects are offered by the industry, and, especially, what prospects of future independence?

BEHOLD, HOW GOOD AND HOW PLEASANT IT IS, ETC.—Messrs. Saunier and Rodanet, who, a few years ago, were at sword's point about some fanciful insult, have, since the first of January, shaken hands across the bloody chasm, buried their little hatchets and everything is again lovely and serene between them. The former gentleman is well known to the horological world as the author of the great "Handbook of Horology." The cause of the quarrel, of which we spoke at the time, was as follows: M. Rodanet, the President of the Horological Syndicate of Paris, instituted some festival for the good of the school. He invited a number of guests, and published the list, at the tail end of which was tagged the name of Claudius Saunier, which this gentleman considered as an act of contumely. "You are another." "You are another." Violent language. Dignified withdrawal of patronage from the *Revue Chronométrique* by M. Rodanet, who, therefore starts his own organ, the *Journal de l'Horlogerie Française*. After the pacification of the two gentlemen, the latter periodical has been fused together with the *Revue*.

THE RUSSIAN CROWN DIAMONDS.—The insignias of the Russian crown have been set in order. The crown is estimated at more than 1,100,000 rubles (according to the standard of the U. S. coin of 1853, 1 ruble=0.806), and consists of two halves, symbolic of the Eastern and Western Roman Empire, fastened together by an arch, upon which is mounted a cross consisting of 5 large diamonds. This admirable work was made soon after Catherine's ascent to the throne, by Court Jeweler J. Panzié, a Genevan. Panzié received the diamonds and worked day and night to have it ready for the occasion. With the exception of one ruby, the crown consists wholly of diamonds and 54 large pearls. The scepter, ordered by Emperor Paul for his crowning (April 5, 1797), is still more valuable. It is ornamented with the unexcelled diamond known by the names of Lasareff or Orloff. It is said that it was the companion eye of the golden lion before the throne of the Great Mogul at Delphi, the other one being none less than the celebrated English diamond Koh-i-noor. The Orloff passed as a piece of glass or topaz from hand to hand, until purchased by an Armenian merchant Lasareff, who brought it to Petersburg and offered it to Empress Catharine II. She considered the uncut jewel too dear, and Lasareff took his treasure to Amsterdam, then the center of the diamond trade. Count Alb. Orloff purchased it here for 450,000 rubles, had it cut, and laid it at the feet of the Empress, obtaining at the same time a patent of nobility for Lasareff together with an annuity of 2,000 rubles. The Orloff weighs 193¼ karats, consequently 8¼ karats more than the Koh-i-noor. It lost 9¼ karats by cutting. It is of unsurpassable water, and in 1865 was estimated at 2,399,410 rubles. The Orloff is surmounted by a finely enameled double eagle. The scepter, in all 81 cm. high, was also used for the coronation of Emperor Nicolai at Warsaw. Also the imperial apple was made for the coronation of Emperor Paul. It is of gold, surrounded by a girdle of 3 rows of brilliants, in the midst of which stands a handsome almond-shaped diamond. The crown of the Empress is far smaller but of the same form, and consists only of diamonds. The total value of these "baubles" is about 12 million rubles.

Workshop Notes.

ALUMINUM SILVER.—The following alloy is said to receive a high luster and polish: Copper, 70 parts; nickel, 23; aluminum, 7.

GOLD TINGE TO SILVER.—A bright gold tinge may be given to silver by steeping it for a suitable length of time in a weak solution of sulphuric acid and water, strongly impregnated with iron rust.

TO WRITE IN SILVER.—Mix 1 ounce of the finest pewter or block tin and 2 ounces of mercury together till both become fluid, then grind it with gum water, and write with it. The writing will then look as if done with silver.

MAGIC POLISH FOR BRASS.—Add to sulphuric acid half its bulk of bichromate of potash; dilute with an equal weight of water, and apply well to the brass; rinse it well immediately in water, wipe dry, and polish with pulverized rotten stone.

TO TIGHTEN A CANON PINION.—The canon pinion is sometimes too loose upon the center arbor. Grasp the arbor lightly with a pair of cutting nippers, and by a single turn of the nippers around the arbor cut or raise a small thread thereon.

TIMING FRENCH CLOCKS.—Scape wheels of French clocks make two revolutions per minute, or four vibrations to each tooth. They may be quickly brought to time by counting if the beats of pendulum per minute equal four times the number in the scape wheel.

TO SOLDER GERMAN SILVER.—Dissolve granulated zinc in spirits of salt in an earthen vessel. Cleanse the part to be soldered, and apply the spirits of salts. Next put a piece of pewter solder on the joint and apply the blowpipe to it. Melt German silver 1 part, and zinc in thin sheets 4 parts, then powder it for solder.

SILVER ASSAY BY SMELTING.—If no lead is present, mix 600 grains of the pulverized ore with 300 grains carbonate of soda, 600 grains of litharge and 12 grains of charcoal in a crucible; add a slight pinch of borax over all, put on the furnace, melt, take off, give it a few taps to settle the metal, let it cool, and remove the button.

PICKLE FOR FROSTING.—Silver goods may be frosted and whitened by preparing a pickle of sulphuric acid 1 drachm, water 4 ounces; heat it and immerse the silver articles until frosted as desired; then wash off clean, and dry with a soft linen cloth, or in fine clean sawdust. For whitening only, a smaller quantity of acid may be employed.

ALABASTER CEMENT.—1. Finely powdered plaster of Paris made into a paste with water. 2. Melt rosin, or equal parts of yellow rosin and beeswax, then stir in half as much finely powdered plaster of Paris. The first is used to join and fit together pieces of alabaster or marble, or to mend broken plaster figures. The second is to join alabaster, marble, and other similar substances that will bear heating.

REGULATING THE BALANCE.—To reduce an exactly equipoised compensation balance to preserve uniform time in horizontal as well as vertical position, it is necessary to equalize the pivot friction to its smallest possible quantity. It is also necessary to see that the jewel holes be not unduly thick, that they are truly round, and well polished. If this is not the case, they are to be corrected to correspond with these requirements, or else replaced by suitable ones.

TO MAKE BURNISHERS.—Proceed the same as in making pivot files, with the exception that you are to use fine flour of emery, on a slip of oiled brass or copper, instead of the emery paper. Burnishers which have become too smooth, may be improved vastly with the flour of emery as above, without drawing the temper. To prepare one for polishing, melt a little beeswax on the face of your burnisher. Its effect then on brass or other fine metals will be equal to the best buff. A small burnisher prepared in this way is the very thing with which to polish up watch wheels. Rest them on a piece of pith while polishing.

FLUORIC ACID.—You can make your own fluoric (sometimes called hydro-fluoric) acid, by getting the fluor, or Derbyshire spar, pulverizing it, and putting all of it into sulphuric acid, which the acid will cut or dissolve. Inasmuch as fluoric acid is destructive to glass, it cannot be kept in common bottles, but must be kept in lead or gutta percha bottles.

TO SEPARATE GOLD FROM SILVER.—The alloy is to be melted and poured from a height into a vessel of cold water, to which a rotary motion is imparted. By this means the alloy is reduced to a finely granular condition. The metallic substance is then treated with nitric acid, and gently heated. Nitrate of silver is produced, which can be reduced to any of the known methods; while metallic gold remains as a black mud, which must be washed and smelted.

TO DRILL AND ORNAMENT GLASS.—Glass can be easily drilled by a steel drill, hardened but not drawn, and driven at a high velocity. Holes of any size, from the sixteenth of an inch upward, can be drilled, by using spirits of turpentine as a drip; and, easier still, by using camphor with the turpentine. Do not press the glass very hard against the drill. If you require to ornament glass by turning in a lathe, use a good mill file, and the turpentine and camphor drip, and you will find it an easy matter to produce any shape you choose.

DEAD WHITE ON SILVER ARTICLES.—Heat the article to a cherry-red, or a dull red heat, and allow it to cool, then place it in a pickle of 5 parts sulphuric acid to 100 parts of water, and allow it to remain for an hour or two. If the surface is not right, rinse in cold water, and repeat the heating and pickling operation as before. This removes the copper from the surface of the article, leaving pure silver on the surface. When sufficiently whitened, remove from the pickle, well rinse in pure hot water, and place in warm box sawdust.

TO RECOVER THE GOLD LOST IN COLORING.—Dissolve a handful of sulphate of iron in boiling water, then add this to your "color" fluid, it precipitates the small particles of gold. Now draw off the fluid, being very careful not to disturb the auriferous sediment at the bottom. Then proceed to wash the sediment from all trace of acid with plenty of boiling water; it will require 3 or 4 separate washings, with sufficient time between each to allow the water to cool and the sediment to settle, before pouring the water off. Then dry in an iron vessel by the fire, and finally fuse.

MOLDING-SAND FOR BRASS OR IRON.—The various kinds of good molding-sand employed for casting iron or brass have been found to be almost uniform in chemical composition, varying in grain or the aggregate form only. It contains between 93 and 96 parts siliceous aggregate, or grains of sand, and from 4 to 6 parts clay, and a little oxide of iron, in each 100 parts. Molding-sand which contains lime, magnesia, and other oxides of metals is unfit for use, particularly for the casting of iron or brass. Such sand is either too close, will not stand or retain its form, or will permit the metal to boil through its closeness.

CORRECT LENGTH OF LEVER, ETC.—It is quite frequently necessary to determine the correct length of the lever, size of table roller, size of the pallets and depth of the escapement of lever watches. A lever from the guard pin to the pallet staff, should correspond in length with twice the diameter of the ruby pin table, and if such a table is accidentally lost, its correct size may be known by measuring half the lever between the points above named. For correct size of pallet, the clear space between the pallets should correspond with the outside measure on the points of three teeth on the scape wheel. The only rule that can be given without the use of diagrams, for correct depth of the escapement, is to set it as close as it will bear, and still free itself perfectly, when in motion. This may be done by first placing the escapement into your depthing tool, and then setting it to the correct depth. Then by measuring the distance between the pivots of the lever staff and scape wheel, as now set, and the corresponding pivot holes in the watch, you determine correctly how much the depth of the escapement requires to be altered.

CLEANING DULL GOLD.—Dull gold may be cleaned in this way: Take 80 grams calcium hypochlorite, 80 sodium bicarbonate, and 20 sodium chloride, and treat the mixture with 3 liters of distilled water. It must be kept for use in well-corked bottles. Goods to be cleansed are put in a basin and covered with the mixture. After some time they are taken out, washed, rinsed in alcohol, and dried in sawdust. The articles then have the same appearance as if new.

TO BRONZE STEEL.—Methylated spirit, 1 pint; gum shellac, 4 ounces; gum benzoine, $\frac{1}{2}$ ounce. Set the bottle in a warm place, with occasional agitation. When dissolved, decant the clear part for fine work, and strain the dregs through muslin. Now take 4 ounces powdered bronze green, varying the color with yellow ochre, red ochre and lamp black, as may be desired. Mix the bronze powder with the above varnish in quantities to suit, and apply to the work, after previously cleansing and warming the articles, giving them a second coat, and touching off with gold powder, if required, previous to varnishing.

SOLDER FOR ALUMINUM.—The following alloys are recommended for the purpose: 1. Melt 20 parts of aluminum in a suitable crucible, and when in fusion add 80 parts zinc. When the mixture is melted, cover the surface with some tallow, and maintain in quiet fusion for some time, stirring occasionally with an iron rod; then pour into moulds. 2. Take 15 parts of aluminum and 85 parts zinc, or 12 parts of the former and 88 parts of the latter, or 8 parts of the former and 92 parts of the latter; prepare all of them as specified for No 1. The flux recommended consists of 3 parts balsam copaiba, one of Venetian turpentine, and a few drops of lemon juice. The soldering iron is dipped into this mixture.

REPLACING A BROKEN PLUG.—A broken pivot in the cylinder requires the replacing of the whole plug, which is done in the following manner: Take a piece of brass with a hole large enough to admit freely the shoulder of the plug, and bevel the hole, so that only the side of the canon will touch. With the plug-driver just start the plug, and then take the riveting stake, put the cylinder on it in a hole which will just admit the plug, and drive it out. Then make a new plug in the same manner as you would do for a new cylinder. Some will put the cylinder in wax, and drill a small hole through the old plug and put in a new pivot only, but this method is good only in very few cases, and it is generally preferable to make the whole plug anew.

REMOVING TIN FROM GOLD.—A correspondent desires to know how he can remove the tin soldering from a gold article. Much depends upon the treatment the tin received in soldering. If it received too much heat, it has penetrated into the gold, and can never be expelled again. This is known when scratching the tin, if it is glass hard it has become incorporated. If, however, it is still soft, scrape it off as closely as possible, and lay the article in a dilute mixture of sulphuric acid and water, and leave it immersed for a few hours. Have a care to have the fluid only strong enough to dissolve the tin, but not to attack the gold. When, after taking out, it should still show black spots, which is a sign that more tin is present, scrape and immerse again.

NICKEL PLATING BY BOILING.—The *Mittheilungen d. Bayr. Gewerb.* says that Dr. R. Kaiser prepares a bath of pure granulated tin, tartar and water, which he heats to the boiling point, and adds a small quantity of pure red hot nickel oxide. A portion of the nickel is soon dissolved, as is shown by the green color assumed by the liquid which stands upon the grains of tin. If articles of copper or brass are plunged into the bath, they become covered in a few minutes with a white, beautiful silvery metallic coating, which consists almost entirely of pure nickel. If a little carbonate or tartrate of cobalt is added to the bath, a bluish shade, either light or dark, may be given to the coating, which becomes very brilliant when it is properly polished with chalk or dry sawdust.

STRAIGHTENING A CYLINDER.—Cylinders are generally bent at the column, and there are two methods for straightening them. The first one is to remove the lower plug and put in a new one. Make your cylinder to run true by throwing the center a little to one side with a file, and then make your pivot without paying any attention to the small canon, which will no longer run true. The second method is, if both pivots are broken and the cylinder bent, remove the two plugs. Take an arbor very smooth and cylindrical, fitting in the straight part of the cylinder. Put the cylinder in a brass collet, covering and touching well the exterior face of the rests. Put the column of the cylinder in contact with a heated wire, and the moment it is blue, carefully put your arbor in the cylinder, and, holding it firmly with a pair of plyers, one jaw touching the arbor and the other the column, immerse the whole in water until cold. Then make the plugs anew.

COLD BLACK PICKLE FOR BRASS.—All hitherto known black and gray pickles possess the defect that they give different colors with different copper alloys, while in the case of certain alloys they refuse to act altogether. For instance, carbonate of copper, dissolved in ammonia, gives to brass a handsome, dark-gray color, while it does not whatever attack various other alloys; therefore it is little suitable for instruments. A dark-gray pickle, which almost indiscriminately stains all copper alloys a handsome gray, resembling in color the costly platinum, is composed by dissolving 50 grams arsenic in 250 grams hydrochloric acid, and adding to the solution 35 grams chloride of antimony and 35 grams finely pulverized hammer scales. The articles to be pickled are to be rinsed in a weak, warm soda solution, prior to as well as after immersion, to be followed by continued rinsing in water. The recipe is simple, and has been repeatedly tested with uniformly good results.

HARDENING SMALL SCREWS, ETC.—A watchmaker who has worked in Swiss factories, gives the following directions for case hardening small articles, say screws: Get a small box made of sheet iron, ordinary sheet, just cut at the corners and doubled over—one should be able to make such a box. Half fill with bone dust, then throw in the screws, then fill up with more bone dust; now put the whole in a fire; put fuel on top of the box, if the operation is performed in a common fire grate; it is not necessary in a furnace fire. When the whole is red hot, lift out with a pair of tongs, and cast the contents of the box in a tub of cold water. Your articles will be case hardened; now get them out the best way you can. If bone dust can not be had, there is another agent which will do as well, especially if a nice mottled color is the object; collect a lot of old boots and shoes, pitch them into the fire and let them burn, till their blaze ceases; pulverize the charred parts, and use them as bone dust.

SIMPLE METHOD FOR SILVER PLATING.—The *Maschinenbauer* contains a simple method by Ebermayer, for providing especially brass articles with a handsome silver coating. It possesses at least the merit of being very simple, and we therefore lay it before our readers for what it is worth. The process consists in exposing the article, which has previously been well cleansed with a potash solution and dilute hydrochloric acid, to the operation of a silver bath, which is prepared in the following manner: From a solution of 32 grams (1 oz., 13.8 grains) nitrate of silver, 20 grams silver (12 dwts., 20.6 grains) in 60 (1 oz., 18 dwts., 13.9 grains) grams nitric acid the silver is precipitated as silver oxide with a solution of 20 grams solid caustic potash in 50 grams (1 oz., 12 dwts., 3.6 grains) distilled water, carefully washed, and the precipitate taken up by a solution of 100 grams (3 oz., 4 dwts., 7.2 grains) cyanide of potassium in 500 grams distilled water. The fluid, distilled through paper, is finally diluted with distilled water to 2 liters (9 pints). The thus prepared silver bath is gently warmed in the water bath, and the article to be silver plated laid in it and kept in motion for a few minutes, and after taking out it is dried in sawdust, and then polished with Vienna chalk for giving luster.

Trade Gossip.

The perfume ring introduced by A. Goldsmith is a great success.

Bright cut silver jewelry is the latest novelty in this style of goods.

Traitel Bros. are making a fine line of initial rings, both raised and incusted, embracing a large variety of designs.

C. C. Adams has severed his connection with the Eugene Jaccard Jewelry Co., of St. Louis, and is now sojourning on his farm at Newburyport, Mass.

J. A. Meyer, of Canton, Ohio, will move into his new store early in November, and will open with a magnificent display of jewelry and other goods.

C. S. Raymond of Clinton, Iowa, one of the most enterprising jewelers in the state, was recently in town purchasing goods for the fall and holiday trade.

A huge pair of solitaire diamond ear rings, in bright yellow, were compared by a famous painter on this side of the water to a "burst of sunshine." "Burst of sunshine is good."

The King of Siam has a collar button in which is imbedded a miniature watch. It strikes the hours, and has an attachment for tickling his nose when he falls asleep while on duty.

P. H. Lachicotte, for the past eleven years in the employ of James Allan, of Charleston, S. C., has opened a jewelry store at Columbia, S. C., under the firm name of P. H. Lachicotte & Co.

Richard Oliver, of this city, has admitted to membership his son-in-law, Mr. Bloomfield. The business will hereafter be conducted under the firm name of Richard Oliver & Bloomfield.

Henry W. Graber, of Brenham, Texas, is reported to have died on shipboard while returning home from Europe. Unfortunately for his family, Mr. Graber was not a member of the Jewelers' League.

Reed, Daily & Bettman, of Minneapolis, have, in consequence of increasing business, added extensive improvements to their store. F. W. Hall, formerly of Roxbury, Vt., is now traveling for them.

The Providence *Press* fully understands the character of its readers. The title of one of its recent articles was, "What are you Drinking?" With one universal shout the boys yelled "Sour Mash!"

Celluloid will not be as popular in the future as it has been, if a new substance which has been made up in London proves successful. It possesses all the hardness and brilliancy of celluloid, and is, besides, fire-proof.

J. T. Scott & Co. invite attention to a large and attractive stock of goods selected with especial reference to this season's trade. The house enjoys a high reputation and are consequently doing a prosperous business.

Messrs. Fowler Bros. have just introduced a new finish in imitation onyx, especially appropriate for mourning jewelry. It is a good imitation of English crape and can be applied to a variety of purposes for articles of personal adornment.

The number of jewelers throughout the country who are diversifying their stocks by adding other kindred and attractive lines of goods, is increasing every day. Those who have given the experiment a trial report very satisfactory results.

J. H. Lamb's store, at Greenfield, Mass., was recently broken into. A hole was drilled through the door of the safe of Harry W. Richardson, the jeweler, the bolts forced off with a screw, and 100 to 150 watch chains, lockets, etc., stolen. The loss is about \$2,000. Several arrests have been made on suspicion.

Edgett & Hamlin have recently established themselves in South Centre, Minn., and carry an attractive stock of goods. Mr. Hamlin was formerly in the employ of F. Talcott, of St. Cloud, and Mr. Edgett formerly with A. B. Hubermann, of Omaha, Neb. They are both skillful workmen and energetic business men.

Special agent Brackett's men recently seized 147 pearls, 100 moonstones, 8 sapphires, 3 rubies, and 1 green sapphire, in a package sent through the foreign mails to the post office. Several packages of diamonds have also been captured in the mails and sent to the seizure room of the custom house to await the appearance of the claimant.

There is every evidence that the holiday trade will be late this season. As a consequence there will be a rush at the last moment, when all the stocks have been picked over, and when manufacturers are driven to the utmost to fill orders. Prudent dealers, who desire to get their goods on time, will see the advantage of ordering early.

We hear of five new watch companies in process of incubation, all of which promise to be improvements upon any heretofore known. The capital involved in these visionary schemes is estimated anywhere from \$5 up to \$1,000,000. We would suggest that they build insane asylums alongside of their factories for deluded stockholders.

Messrs. A. J. Warner & Co. and Reed, Daily & Bettman had an imposing representation in the recent procession at Minneapolis, held in honor of the opening of the Northern Pacific R. R. Many of the retailers of that enterprising city also took part in the celebration, and the tastefulness of their display added greatly to the interest of the occasion.

Messrs. M. W. Galt, Bro. & Co., of Washington, D. C., furnished the prize cups and vase for the Potomac River Regatta. These trophies are from original designs and entirely out of the conventional styles of race cups. They are exceedingly beautiful specimens of the silversmith's art, and reflect great credit on the good taste and enterprise of Messrs. Galt, Bro. & Co.

Chicago scientists are again arranging to try the pendulum experiment to ascertain definitely whether the earth revolves faster at that point than elsewhere. Having doubtless heard of Professor Proctor's statement that the earth will have lost three minutes in two thousand years, they want to show that they are coming in on time, even if St. Louis and the rest of the world don't.

The jewelry store of Henry Mather at Meriden, Conn., was entered by burglars on the night of September 8, the safe blown open, and \$4,000 worth of valuable goods carried off. The safe was a large one, and to get at the contents the burglars were obliged to cut it to pieces. It was evidently the work of experts, who went prepared for any emergency. No clue to them has been obtained.

H. Muhr's Sons have just acquired the right to the use of a glyptic letter alphabet, which new designs they intend introducing immediately in initial rings. It is a very beautiful and artistic letter, and cannot help but become popular. This firm has also introduced filled cases for ladies' size movements, ornamented in the various styles of decoration found in their gentlemen's cases.

Messrs. Jacot & Son, importers of musical boxes, have just issued an excellent work on "How To Repair Musical Boxes," which they will forward to any address on receipt of twenty-five cents. It is published in pamphlet form, and contains much valuable information in regard to this class of instruments, which are growing in popularity, and in regard to which workmen generally know so little.

While there is every indication of a prosperous harvest this year, the yield of precious metals promises to keep pace with the general prosperity of the country. Director of the mint Burchard announces the likelihood of a slight decline in the yield of gold and an increase in that of silver during the present over last year, which must of course be regarded as a satisfactory proof of the present healthy condition of mining interests throughout the country.

Widows' mites are now furnished by Cincinnati jewelers to the piously inclined millionaires of the city. They are of battered copper, with illegible characters on the side, an equivocal character—Tiberius Cæsar by name—on the other. They are about as large as a 3-cent piece, and the rich man says there is high authority for supposing that it is more blessed to put one of these into the church box than great worldly treasures, while he feels sure that it comes much easier to do it.

A well dressed chap recently entered a New York jewelry store and asked if he could see some silver cups that were exposed in the show case. "Them," said the jeweler, handing him one, "are race cups." "Race cups—what are race cups?" "Why," replied the jeweler, "they are cups I had ordered to be made for prizes to the best racer." "Well, if that's so, suppose you and me race for one," and with the cup in hand started, the jeweler after him. He probably won the cup.

David Gumbiener, a watchmaker, shared his shop, at 62 Hester street, with David Gordon, a jeweler. On the afternoon of the 17th ult. he went out, leaving the shop in charge of Gordon. When he came back Gordon said that he, too, had been out and had locked the shop up, and that in his absence burglars had broken in. Eleven of Gumbiener's watches had been stolen. A policeman, who looked at the door, concluded that the lock had been wrenched off from the inside. Gordon was arrested.

During the past month the Texas jewelry trade has been well represented in this city, there having been more buyers from that State in town than has been noticed before in many years. Many of them have taken the advice given by THE CIRCULAR, and in addition to buying jewelry liberally, have laid in stocks of fine stationery, perfumery, and fancy goods generally. They represent that Texas is growing rapidly, and is prospering, and offers splendid opportunities for business men of all kinds.

John C. Warnock, for many years a traveler in the employ of the Meriden Britannia Co., recently returned from Europe in the steamer *France* in a very feeble condition. Mr. Warnock has for many months been a great sufferer from a distressing spinal affection, from which he could get no permanent relief. By advice of his physicians he visited Europe, and consulted the best medical authorities in France and England, but failing to derive any benefit to his health, returned home and is now confined to his bed.

The silver dollar has increased from \$94,016,842 in January, 1883, to \$114,320,197, on August 31, 1883. If the Government to-day should sell the whole lot for old silver, not more than \$75,000,000 could be realized. Over \$20,000,000 locked up in the Treasury for eight months, means \$30,000,000 by December 31, 1883, or a total of \$124,000,000 from the time the measure became a law. The only people who seem to profit by this pernicious system of financiering are the men who passed the bill and who mine and sell the bullion to the Government.

A rare old coin was recently found in the principal street of Waterville, in Maine, about three feet below the surface. It is stamped with the escutcheon and cross and the emblems of Catholic episcopal authority, and the legend "Spina Sanchis." Over this is the motto, "Pro patria et Avalonia." Avalon was the Newfoundland province granted to Lord Baltimore before the province of Maryland was granted to him. The other side of the coin bears a harp. Lord Baltimore's charter gave him royal powers, and the right to coin money was included.

A Thermometer once was Observed in a State of Excessive Agitation. "Why, my friend," inquired the Eight-day Clock, "why are you so Perturbed?" "Because," replied the Thermometer, "I apprehend that I am no Longer Capable of Performing my Functions. At the present Moment I am Registering forty Degrees above Zero when I should be Several degrees Below." "Oh, no, I guess Not," said the Eight-day Clock. "Yes, I am confident of it," persisted the Thermometer, "for from my Position in this window I just heard a Providence Box man decline a drink, and its a cold day when such a Phenomenon occurs."

Messrs. John Wilson's Sons have just issued a very elaborate catalogue showing an extensive line of French clocks and holiday novelties. The clocks are in both gilt and marble cases, with side and top ornaments in French bronze. The illustrations are large, well executed and clearly defined, and are accompanied by detailed descriptions of size, finish, and style of dials. The arrangement of the catalogue is neat and comprehensive, and will be very useful to dealers who carry but a limited line of clocks. They also publish another catalogue showing novelties and special designs in flower stands, jewel cases, etc.

The ninth annual meeting of the Jewelers' Association was held at their rooms, No. 692 Broadway, September 12, when the following named gentlemen were elected officers for the ensuing year: President, Thos. G. Brown; Vice-President, Wm. R. Alling; Treasurer, Aug. K. Sloan; Executive Committee, F. S. Douglas, G. C. White, Jr., D. F. Appleton, D. C. Dodd, Jr., Alf. H. Smith; Finance Committee, John A. Riley, S. W. Hale, L. B. Haff, J. F. Chatellier, C. E. Bulkley; Membership Committee, C. H. Brahe, J. D. Lyon, E. Richardson, C. P. Harris, W. S. Hedges. The date for the annual banquet has not yet been determined upon.

A reputable and honorable firm has called our attention to a letter written them by James K. Norman, of Nevada, Missouri. This creature wrote to the firm asking for certain goods, in reply to which they referred him to his nearest jobber, as their dealings are exclusively with them. In response to this Norman wrote the firm the most scurrilous, indecent, blackguarding letter we ever read; wherein he uses language that would disgrace the denizens of the Five Points. In it he said that he had applied to jobbers for these goods and could not get them. We presume this is true wherever he is known. A man who could write such a letter as he did is not worthy the consideration of reputable men. We are happy to know that the retail trade is not disgraced by many creatures of this caliber.

For many years past it has been known that large sums of gold are lying hid in Egypt. It is calculated that about £40,000,000 in bullion has, from time to time, been imported into the country. About £6,000,000 of this is in circulation, and it has recently transpired that during the Vice-royalty of Ismail Pasha another £6,000,000 was secretly transported to Constantinople. This leaves £28,000,000 unaccounted for, and this sum must either have been absorbed in the gold ornaments of the country or must be hidden away. Should good government bring peace and security to Egypt, this or a considerable portion of this sum will return into circulation and assist in the development of the country.

The numerous friends of A. C. Titcomb, of San Francisco, have recently noticed the development of many eccentricities in that gentleman, and were at a loss to account for them. They knew that something was working in his gigantic intellect, but whether he contemplated suicide or being a candidate for the Presidency, was a conundrum none could solve. The secret has at last been solved by the circulation among his friends of the announcement of his approaching marriage, on October 3, to Miss Hettia Louise Clement, daughter of the Hon. A. C. Clement, of Plaiston, N. H. The happy pair will visit Montreal, Quebec, and the Thousand Islands, afterwards proceeding to San Francisco. The entire trade wishes the bride and groom all the happiness to be had in California, or elsewhere.

A notorious sneak thief named George Williams, with numerous aliases, has been sentenced in Rochester, N. Y., to four years' imprisonment for grand larceny. On March 29 Williams entered the jewelry store of J. D. Hawley, in Syracuse, and asked to look at some diamonds. The goods were shown, and while looking at them succeeded in abstracting a diamond solitaire ring valued at \$175 and substituted for it a paste diamond worth \$2. He then went to Rochester and attempted the same game with E. B. Booth & Son, but it did not work. Williams was arrested and the stolen diamond was found on a table in the store, also two paste diamond rings, but nothing was found on the prisoner. On searching his baggage, however, the officers discovered one valuable ring and six imitation diamonds in gold settings. The prisoner was tried on the charge of stealing diamonds at Syracuse, waived examination, and was held for the Grand Jury. He was duly indicted, convicted, and sentenced. He confessed, after the sentence, that he had started out from New York for the purpose of swindling jewelers from New York to Chicago. W. A. Pinkerton, of the latter city, has informed the Rochester police that Williams is an old-time professional thief and burglar. He is one of the most cowardly thieves in the world, although very expert. He was convicted in 1879 for stealing, in company with three other men, a sample trunk belonging to Max Freund & Co., of New York, containing jewelry valued at \$25,000. He is well known in this city as a dangerous thief.

"Have you any jewelry that you wish mended, or clocks to repair or regulate?" It was a young woman, neatly dressed, who asked the question at the front door of a house on Taylor street, yesterday. The mistress of the establishment remembered that she had a brooch with a pin lacking and handed it over to the itinerant jeweler to operate upon. Her actions showed that she was an adept at the business. In a neat box, about fifteen inches long and five high, were ranged a full kit of jeweler's tools, including a spirit lamp and blow-pipe. A new pin was speedily attached to the brooch and turned over to its owner. "How much is it?" "Twenty-five cents," was the reply. Having paid the amount, the inquisitive lady of the house asked the traveling jeweler whether she had much work to do. "Oh, plenty," she answered. "In some houses I am kept nearly a day overhauling clocks and doing little odd jobs of mending. In some places I have fixed as many as a dozen clocks." "Do you have much regulating of clocks to attend to?" "You would be surprised if I should tell you how many people there are who do not know how to make a clock run faster or slower. But there are very many. There are some people, too, who have some expensive clocks who do not care to tamper with them, and in such places I am always asked to look after them." "How do you manage to make repairs where it is necessary to drill holes?" "Oh, that is simple enough. I have drills and a small lathe that I can attach to a sewing machine, and there is scarcely a house now that does not possess one of those useful articles." "Are there any other ladies engaged in the work you are?" "Not in this city that I know of. But I expect that there will soon be plenty of competition, as there are many young girls learning the business at the east. But we can all find plenty of work, I guess, as there is an awful amount of breakage in jewelry, and we can, if worse comes to worse, always work for less than men with big establishments and high rents to pay."—*San Francisco Chronicle*.

On the night of September 17, burglars gained access to the building in Philadelphia occupied, among others, by Joseph Koons, manufacturer of jewelry. The burglars went to the rooms in the second story, used by Joseph Koons, where they broke open the safe and took therefrom jewelry of the estimated value of \$2,000. In a large drawer of the safe there were valuable rings, watches, and other goods; but, although the key had been left in the lock, the thieves, in their haste, seem to have altogether overlooked it. Under the safe there was a tray of fine gold watches, and these, too, escaped their notice. The burglars appear to have been very much hurried in their work, but nevertheless, left no clue to their identity. Detectives subsequently arrested James Logue and Samuel Torrance on suspicion, and will endeavor to connect them with the robbery.

A Hartford genius may be said to be the most multifarious tradesman in the State of Connecticut, having mastered no less than twenty-two distinct trades, and being what is still more strange, a first-class workman in every one of them. He is not yet 70 years old, and is vigorous and hale and able to do a man's work any day. Here are the vocations he has learned: Blacksmith, house carpenter, cabinet maker, ship joiner, ship carpenter, glass cutting and grinding, shoemaking, harness making, wheelwright, iron machinist, wood machinist, mathematical instrument making, wood carving, pattern making, clock and watch making, cooper, carriage maker, gardener and florist, moulder, patent office model maker, plumbing and locksmith. He is a genius in mechanics, and ascribes his ease in learning trades to "an accurate eye and a mechanical head." In addition to all the above named useful avocations may be added the fact that he is a good musician and one of the best rifle shots.

In old days the utmost perfection that was possible at the time used to be found in the work of the goldsmith. Benvenuto Cellini was but one of a great many illustrious artists whose names are associated with the craft, as the collection of reproductions at South Kensington will demonstrate. It can hardly be said that of late years in England goldsmiths' work has kept pace with the advance of other branches of industrial art. Even the race cups, for which the help of sculptors is sometimes invoked, at a high price, are by no means superior to those produced thirty or forty years ago. The cause of this decline, without doubt, is in a great measure due to the high duty which is levied on gold and silver plate. At the present time, and for the last sixty years, that duty is 17s. per ounce on gold and 1s. 6d. per ounce on silver. What is worse, the duty is mainly levied on that class of plate with which artists would have most to do. Chains, bracelets and the like are not liable to it, and all articles which cannot be assayed without damaging, prejudicing or defacing, or which are too small to be safely marked. Under such capricious circumstances it is not profitable for a manufacturer to produce gold plate of an artistic character. Yet a Committee of the House of Commons are adverse to an alteration in legislation, one of their reasons being that the system has existed for the last 500 years.

A watch formerly owned by David Crockett, has turned up in Louisville, Ky. It is now in possession of Mr. Crockett, a grandson of the old hero of the Alamo. The ancient timepiece is a noteworthy one apart from its associations. It is of ordinary gentleman's size, but rather thicker than the watches of the present day, and is open-faced, with a white dial and the hour and minute hands, the second hand not being employed in the construction of timepieces of that day. The case is perfectly plain and smooth, and long use has worn it very thin. It is of solid gold, and on the back are engraved the names of its different owners. The inscription is cut deeply in ordinary letters, the names having been placed there by each possessor from the time of the first Crockett. Very little of the movement can be seen, but it bears the stamp of Robert Raskell, Liverpool, and is full jeweled. It is still in excellent running order, never having had any part renewed but a winding chain or two, and keeps fair time. The watch was purchased by David Crockett before he left Tennessee, after he was defeated in his last race for Congress. He wore it for some time, and just before going on that fatal expedition which terminated with his death at the Alamo, he gave it to his eldest son, Mr. John W. Crockett. The latter also went into public life, and was three times a member of Congress from the Volunteer State. He afterward went to New Orleans, where he engaged in mercantile life. Upon his death the watch descended to his eldest son, Robert. He was also a citizen of Tennessee until about twenty-eight years ago, when he removed to Arkansas, where he has since resided. He is still living, but has turned the watch over to his eldest son, the present owner. Mr. Crockett is naturally very proud of the watch, and guards it with jealous care. He says that he has been offered \$500 cash for it, but no amount of money would induce him to part with its possession.

We are asked to insert an advertisement for a peripatetic jewelry concern that styles itself "The Jewelers' League, of Providence, R. I." This concern seems to be on wheels, traveling from place to place, and in each advertising "wonderful bargains," watches, diamonds, jewelry of all kinds, precious stones, plated ware, cutlery, etc. We know of no respectable or responsible firm doing business under the title of "The Jewelers' League, of Providence," and do not believe there is any such lawful organization. The only "Jewelers' League" we know of is the trade benevolent society of that name, of New York, and our private opinion is that some one is attempting a deception on the public—"stealing the livery of heaven to serve the devil in." Dealers having legitimate and honest goods to dispose of are not in the habit of hawking them about in this manner. While we must decline the advertisement tendered us, we give the concern this "first-rate notice" without charge.

Adelheid Richmodus, wife of one of the mediæval senators who swayed the destinies of Cologne, died, to all appearance, and was buried in the vaults of the neighboring Apostelkirche. It was said that a valuable ring could not be removed from her hand, and was consequently interred with her. This excited the cupidity of the sexton, who came at night to steal, and failing in his efforts to loosen the ring, tried to sever the finger. Blood flowed; the lady revived and sat up in her coffin, to the horror of the thief. After the first paralyzing shock of finding where she was, she passed through the gates he left open in his flight, and, still wrapped in her winding-sheet, knocked at her husband's door. The servants, on looking out, recognized her, and rushed terrified to their master to say they had seen her ghost; but on calmer reflection, Adelheid continuing to knock and beg plaintively for admission, they concluded she was alive, and said so. Richmodus declared the whole a trick of the imagination, and said he would as soon believe his horses were transported to the attics as that his wife lived. As he spoke, the clatter of hoofs above proved his incredulity rebuked by a miracle. The door was opened to the shivering lady, who told her story and was affectionately received, becoming "the joyful mother of children," and dying in reality at an advanced age. The horses' heads carved in wood, painted one black and one gray, still look from the top window to convince the skeptic; and the next street, Richmodstrasse, is named after the much-enduring woman.—*London Society*.

A circular issued by W. H. Thorp, Secretary of the Wisconsin Jewelers' Association, states that the annual meeting, recently held, was a success. We are glad Mr. Thorp can see the matter in that light, as our information is right to the contrary. However this may be, we heartily endorse the sentiments brought out on that occasion, regarding certain evils in the trade, to which the circular referred to alludes as follows: "It was unanimously agreed that illustrated catalogues were not needed, and if their publication could not be stopped in any other manner, it would be advisable for every retail jeweler in the country to utterly refuse to buy a dollar's worth of goods from any jobber who issued an illustrated catalogue of watches and jewelry. Traveling auctions, of all kinds, are working the trade a great injury; for while the business men of every city pay a good share of the taxes, an auctioneer, by paying a nominal license, come into a town and sell a lot of inferior goods, and take away a lot of cash that ought to be paid out to the merchants of the place. If the business men of the different cities would unite in a petition to the proper authorities, setting forth the facts in a clear manner, ordinances can be passed placing the licenses at such sums that auctions will prove unprofitable. Peddlers, too, are a great detriment to the legitimate trade; but under existing laws, they can get a license from the State, and municipal authorities can not interfere with them. Hence, if it is desired to suppress the peddling traffic, it would be well to unite in a monster petition to the Legislature, requesting it to repeal the present statute and allow the several counties to issue such peddlers licenses at such sums as they deem proper." The circular concludes by an earnest appeal to members to pay their dues, and a reference to the Jewelers' Guild. He omits to mention, however, to what purposes the annual dues are applied.

Just as we go to press we learn with regret of the death of Joseph Baker, of Rock Island, Secretary and Treasurer of the U. S. Guild. Mr. Baker is reported to have been thrown from his wagon while out riding, and sustained such injuries as ultimately caused his death.



THE JEWELERS' CIRCULAR AND HOROLOGICAL REVIEW

The recognized organ of the Trade, and the official representative of the Jewelers' League.

A Monthly Journal devoted to the interests of Watchmakers, Jewelers, Silversmiths, Electro-plate Manufacturers, and those engaged in the kindred branches of art industry.

SUBSCRIPTION:

To All Parts of the United States and Canada,
\$2.00 Per Annum; Postage paid.

To Great Britain, France, Switzerland, Germany, the West Indies, Mexico, the Republics of South America, and Australia, \$3.00 per annum. Postage paid.

All communications should be addressed to D. H. HOPKINSON, 42 Nassau Street, New York. Advertising rates made known on application.

THE JEWELERS' CIRCULAR AND HOROLOGICAL REVIEW enters upon the Fifteenth year of its publication with the issue of the February number. In accordance with an established custom, all Subscriptions terminating with the present volume, ending January, 1884, will be discontinued if not renewed. We hope to have all our old friends continue with us, and to add many new names to our list of Subscribers. Of late we have received several complaints from Subscribers stating that they do not get their paper regularly; we can only say THE CIRCULAR is forwarded promptly each issue to Subscribers. We hope that our friends will notify us at once if THE CIRCULAR fails to reach them on its monthly mission; on so doing we will forward the missing copies.

Condition of the Retail Dealers.

THE financial condition of the retail dealer is better now than it has been for many years. Various causes have tended to make it so, but the principal reason lies in the fact that year by year dealers are becoming better merchants, and, consequently, conduct their business on a more business-like basis. Two or three years ago the retail trade was heavily overstocked with goods that were attractive at the time but soon became unattractive, owing to changes of styles and designs. This was a heavy load for dealers to carry, but they gradually worked off the old goods by submitting to something of a sacrifice, and have now very generally recovered from the effects of their unwise purchases. Now their stocks are cleaner, better selected and more attractive than ever before, and business is correspondingly sounder. They are also under less obligation to the creditor class, having learned by experience that it is a costly thing to be in debt. The wholesale trade complains that the retailers buy less liberally and more discriminatingly than formerly, ordering fewer goods, exercising judgment in selecting, and

appear to be afraid to burden themselves with goods for which they do not readily see the means of paying. Many of them have learned that there is a decided advantage in limiting themselves to such purchases as they have the means to promptly pay for. This class finds that the sums saved in the way of discounts, interest, etc., foots up quite a respectable profit at the end of the year.

While it is true that the trade, under these conditions, is lacking in that spasmodic "go" and "vim" that formerly characterized it at certain seasons of the year, it does not materially affect the volume of trade for the year. Retail dealers, instead of buying liberally at certain intervals—stocking up in the spring and fall—spread their orders over the entire year. It may be compared to railroad travel. There are, say, 100,000 persons who desire to go to Chicago some time during the year; instead of all rushing over at once, crowding the cars to their utmost capacity, they go a few at a time, and so furnish steady occupation for the transportation lines. [Just why anyone ever wants to go to Chicago, however, we have never been able to discover]. Manufacturers of jewelry express some irritation at this change in the condition of trade, but, after they have accommodated themselves to it, they will approve of it. If it enables them to run their factories steadily throughout the year instead of fitfully, part of the time working a full force night and day, and at other seasons running half a force half the time or shutting down entirely, it will be better for them, and certainly far better for the workmen.

There are many things to be said in favor of retail dealers shortening credits. In the first place it secures them special advantages whereby they get their goods much cheaper; it teaches them to exercise greater care and judgment in their selections; they are less liable to be persuaded to buy more goods than their custom demands; they are under no obligation to the creditor class, and no man can overhaul their stocks and say "these goods are mine." But one of the greatest advantages in buying for cash lies in the fact that the outside dealers, who do pay cash as a rule, have no advantage over you in the cost of the goods, and cannot run a disastrous competition with you. As we have heretofore explained, one great inducement to the wholesale trade to sell to outsiders lay in the fact that they were cash buyers, and by selling to them the manufacturers were enabled to turn their money over more rapidly. A manufacturer who sells goods on long time must necessarily have an extra amount of capital in his business; he is forced virtually to carry three or four stocks of goods—one in process of manufacture, one in the hands of his salesmen, and another in the hands of dealers who have not paid for them. It takes large investments to carry on a manufacturing business on this basis, and the men who buy on time are the ones who must pay for the use of this extra capital. If these are the retail dealers, so much the worse for them, for the cash buyer who competes with them will have the advantage over them. Manufacturers may complain that retailers buy from hand to mouth instead of stocking up liberally at certain seasons of the year, as they formerly did, but the hand to mouth business on a short credit basis is what will be the salvation of the retail trade. It is a noticeable

fact, that since the spring and fall rushes by buyers have given place to this hand to mouth buying to a considerable extent, there have been fewer failures in the trade, and such as have occurred were not of a serious nature. There have been some very bad failures in other lines of business during the past year, but the jewelry trade has been remarkably free from them. The pay-as-you-go system is by far the best on every account. We are well aware that the immense volume of business transacted annually by the jewelry trade cannot be conducted in disregard of the credit system, but we maintain that the nearer the retail dealers can come to conducting their share of it on a cash basis, the more independent they will be and the better it will be for them. So long as they ask six, nine, twelve or eighteen months' credit, so long are they in the hands of the creditor class and must pay for the accommodation they receive. This is a law of commerce, and is universal in its application, affecting the jewelry interests no more than it does any other. Of course there is a class of improvident dealers, who were born behind time and will always be behind hand; they are always in debt and always will be. They do their business in a slipshod, happy-go-lucky manner, and look to some state association or other trade organization to boost them along. They are incompetent to do business, and grumble because customers and liberal profits do not come their way. This class of dealers have been dragging out a precarious existence for years, and are no better off this year than they were last, and will not be next any better than they are this. Our remarks do not apply to this undesirable class of men.

Another reason why the retail trade is in better condition than heretofore lies in the fact that a large number of dealers have adopted the advice so emphatically given by THE CIRCULAR, and added other attractive lines of goods to their stock, so that they are competing on a more equal footing with outsiders. We are in receipt of letters from dealers in all sections of the country stating that they have tried the experiment and found it to work most admirably. They have put in a variety of ornamental and useful articles—perfumery, toilet art goods, bric-à-brac, musical instruments, stationery, etc.—which, they report, has livened up their stores, made them attractive, and considerably increased their sales of jewelry. One thing helps to sell another, and a person who drops in to buy a little stationery is often attracted to an article of jewelry, and ends in becoming a purchaser. One dealer writes that the plan of diversifying his stock worked to a charm; it attracted marked attention to him, and in less than a month he had half the trade that formerly went to his fancy goods competitor. Another writes that his diversified stock proved such a card for him that two outsiders, who had been dealing in jewelry, offered him their goods at cost, and promised not to buy any more if he would not infringe upon the other lines of goods they were carrying. These fancy goods, etc., are not generally costly—at least one can make an attractive addition to an ordinary jewelry stock with little expenditure—and they not only serve as a good advertisement, but help to swell the profits of the business. Retail dealers have suffered considerably more than usual during the past year or two in consequence of certain wholesale houses selling to outsiders, but the remedy for this lies in a diversified stock, attractive goods, and low prices to insure quick sales. Carrying the war into Africa is as good a plan to follow in commercial matters as in the camp.

Peripatetic auctioneers and peddling tramps continue to annoy the retail trade, many of them being furnished with their cheap and worthless goods by an unscrupulous class of manufacturers and jobbers who claim to sell only to the legitimate trade. The way to head off these tramps of the road is to advertise them liberally in the local papers, and by circulars and hand bills. Usually these peripatetics lay out a regular route through a state, visiting certain cities and towns in rotation. It would be a good idea for the dealers on a route where they appear to combine their efforts, and give them such an amount of free advertising as will destroy their prospects of success. While the public is easily deceived, it is, nevertheless, extremely wary when once put on its guard,

Disreputable Practices.

THERE IS a class of manufacturers of cheap goods that has done more injury to the retail trade than all the catalogue and price list jobbers that ever sought to sell goods by retail at wholesale prices. This class comprises those manufacturers, mostly located in eastern cities, who make the cheapest grade of goods in imitation of the better grades, and while claiming to sell exclusively to jobbers, solicit the retail trade, and then fill up outsiders to their full capacity. When charged with this double dealing, they will sometimes admit the offence, but plead in extenuation that they have only sold to some large retail dealer who would not buy from the jobber. This is simply specious pleading, for, as a matter of fact, they keep their drummers out constantly seeking victims in the retail trade, and will sell to anyone who will buy, be he a large or a small buyer. The truth of this assertion may be demonstrated almost any day by watching the Astor House, where numbers of their drummers make their headquarters. Let a retail dealer from the country put in an appearance there, and he is forthwith besieged by half a dozen of them, each one being more anxious than the other, if that is possible, to sell him goods. Samples are produced and he is invited to make his selections. Terms of payment are less of an object than getting rid of the goods, and the unsophisticated dealer is made to feel that he is an important person in the trade. He is courted and slobbered over, his vanity flattered by the amount of credit offered him, till he imagines himself a necessary factor to the success of the great jewelry industry. Metaphorically speaking, these greedy drummers tie a mackerel to his coat-tail, and induce him to think he is a whale. He swells up under this inflation, till he becomes as overbearing and pompous as a Chicago jobber. Being captivated by this adulation, he is very likely to be carried off bodily by some enterprising drummer to Providence or Attleboro, to visit the house and factory represented by the drummer. Once there, he is a gone case. He is shown the stock and is induced to buy liberally—his credit is good for any amount of goods he will order. As a consequence of this process, dealers of this caliber are sure to over-buy, and to load themselves down with a stock they cannot dispose of in five years. They are flattered at the idea of buying on the same terms that jobbers can, and contemplate with satisfaction large prospective profits. They order dozens of certain things where they ought to take not more than a twelfth of a dozen, and squander their credit in the most lavish manner. In the end they find themselves with a large quantity of goods on hand, all selected from one stock, having little variety in style or design, not one quarter of which is marketable in their community. Such dealers should confine their purchases to a single jobbing house, instead of running after that will-o'-the-wisp "jobbers' discounts." The manufacturer who will give a small dealer the regular discount made to jobbers, is to be looked upon with suspicion. There is something wrong somewhere, to account for such an anxiety to get rid of his product. Either the goods are not what they are represented to be, or they are passé in style. To enable a manufacturer to give the jobbers' discount, the purchaser must buy liberally, and, in the case of a small dealer, he can only do this by buying more goods than he can sell. Then he has to carry them over from year to year, and finally work them off at a sacrifice. Jewelry is like fruit—it won't keep more than one season. New styles come in vogue and destroy its value. The proper place for the retail dealer to buy his goods is from the jobber. Let him select some good, reputable house—and there are many such—and deal exclusively with it. Such a house will familiarize itself with the general character of his business, take an interest in it, and render him valuable service in a great variety of ways. In buying of a reputable jobber, the dealer has an opportunity to select from the products of a dozen manufacturers, to see all the novelties produced, and to buy intelligently and with discrimination. This is of far greater advantage to him than the small discount a manufacturer would give him, while limiting to the goods of his own exclusive manufacture.

The manufacturers who seek the retail and outside trade are

a double injury; they injure the retail dealer by overstocking him and persuading him to buy more than his market warrants, and they injure the jobber by depriving him of custom that legitimately belongs to him. Both are supplied with more goods than they can sell, and they become passé on their hands. Stock carried over from year to year must be sold, if at all, at a sacrifice, so prices are marked down time and again till so low a figure is named eventually that if the original cost price had the smallpox the selling price would never catch it, they are so far apart. The retail dealer who buys direct from the manufacturer may hug the fond delusion that the special discount given him is to be the foundation of his fortune, but, nine times out of ten, he will find the discount has been more than swallowed up in interest on his indebtedness and in the sacrifice he has been obliged to make in price to dispose of the goods. While the jobber has a legitimate and continuous interest in the retailer, the manufacturer is only interested in him to the extent of his present purchases, having no assurance that the drummer for some other cheap-goods house will not catch him next year. The jobber expects to sell the retailer on time; the nature of the business requires it, and he is provided with the requisite capital to do it, while the manufacturer requires all his capital in his business, and has little patience with the retail dealer, however anxious he may be to capture him. In all manufacturing lines of business the jobber's position is recognized and well understood. His establishment is looked upon as a sort of depot to which manufacturers consign their goods, and where the retail dealers can come and see the various styles and make their selections. Until recently this distinction was observed in the jewelry trade, so far as certain lines are concerned. In handling fine grades of gold goods, manufacturers deal with the retail dealers direct, but the cheaper goods were formerly handled almost exclusively by jobbers. But since these manufacturers of debased imitations of the cheap varieties of jewelry have taken the field, the jobber is largely ignored. Or, rather, these double-faced producers seek to cater to both jobber and retail dealer, and also skirmish very actively for the outside trade. Some go so far as to have two or more drummers for each kind of custom they seek, and sometimes the drummers sell the different ones out of the same trunk. Retail dealers should stand by the honest, legitimate jobbers, and have nothing to do with the class of manufacturers we have described. They should also beware of that class of jobbers who send catalogues and price lists to outsiders, and thereby seek to steal their trade from them. Both these classes are striving to ruin the business of the retail dealer, and are deserving of no consideration at his hands.

The Diamond Trade.

BRADSTREETS ASK what has become of all the diamonds mined from the earliest times. This is a question to which no determinate answer can be given. Some have been buried to escape the ruthless grasp of invaders, others lie at the bottom of the ocean, while a considerable quota has been lost by fire and other accidents. Allowing for disappearance by these causes, diamonds of an incalculable aggregate value must be stored in private hands. India is suspected by many as being the great absorber. The old mine stones of extreme beauty and value, and which never fall off in price—stones gathered ages since—are still objects of search in European Turkey and throughout Central Asia, and are among acquisitions. A larger proportion of the diamonds which have constituted the stock of trade since 1870 has come from the South African diamond fields, a fortunate resource after the comparative exhaustion of the India and Brazil mines. Brazil supplies limited quantities of extremely fine stones; so also Ceylon. The stones from India are bought at all prices. South African yield is not confined, according to the general impression, to medium and low grades. Large London and Paris houses have traveling and residential buyers in India, Turkey and other countries. The product of the Kimberley mines,

which occupy an area of one and a quarter square miles, with those of other neighboring mines, and are worked by a number of companies with an aggregate capital of \$32,000,000, is controlled by London, French and Dutch syndicates, whose buyers are on the spot, and whose prices at times greatly differ. The aim of each is to consolidate, as far as possible, mining interests in its favor, while they unite in action taken to a certain extent. They are always ready to make advances when mines are working at a loss, or to place goods on the market which they have not succeeded in buying up, securing themselves by a broad margin on the sums advanced. The principal market for rough diamonds is London. These are mainly cut in Amsterdam and Antwerp. The former city has 6,000 cutters of unsurpassed reputation. Large steam factories for cutting have been established there, each containing several hundred machines. The business is singularly individualized, the cutters separately, or in combination with others of the craft, buying and selling stones. As this country is getting to be an important diamond market there is no reason why New York should not hereafter do most of its cutting.

Fine qualities of diamonds, those which are not off color and in other respects all but perfect, are getting scarcer, particularly blue white. Prices of all grades have steadily advanced since the curtailment of the South African supply. Diamonds in the rough of low grade that brought at the South African mines in February last 30s. per karat now realize 52s. 6d. The stock held here is larger than usual, advantage having been taken by our importers of the low prices then prevailing in the European diamond marts in anticipation of a more than ordinary active trade. In the last two months the advance on rough stones has been fully 40 per cent., and on cut stones, which are but half the original bulk through the process of cutting, 20 per cent. Prices are still going up, there being no prospect of full operations being resumed at Kimberley mines for a year or more. While values are variable among the syndicates at the Cape, they maintain a certain uniformity in the European centers of the trade. The business of buyers is thus mainly in suitable selections. Transfers are continually taking place between these centers, no customs duties interfering. An intending buyer will often have the very same parcel he has inspected in Paris submitted to him in London. A few months ago, trade being dull here and prices off, it might have paid to re-export diamonds to Paris or London, but the narrow margin of the profit, with duty paid, did not justify the venture. The improving scale of the American trade is in part due to the circumstance that the wear of diamonds by ladies is not confined in the United States, as in Europe, to dress occasions. The American trade limits its purchasers to well cut stones, and retail diamond dealers abroad and at home agree that of all purchasers Americans are most appreciative and critical. A circumstance that facilitates assessment of values in this line is that when the eyes have become familiarized to a fine diamond, any inferior grade as to form and brilliancy can at once be detected. New York, as the great diamond center of the country, necessarily receives the great bulk of importations. The import trade in diamonds has more than trebled the past ten years. The Treasury customs returns blend fancy stones and diamonds under the head of precious stones. The latter do not amount to a tenth of the aggregate value stated. The aggregate value of "precious stones" in the last three official years was as follows: Year ending June 30, 1880, \$6,698,488; 1881, \$8,090,411; 1882, \$8,444,525. A moderate number of rough stones are imported, as these escape all duty, and the services of expert cutters are now obtainable here. The former duty of 15 per cent. on loose stones, cut, was unchanged by the amended tariff. The mounting of diamonds, bringing them within the classification of jewelry, entails a duty of 25 per cent., and so prevents the importation of jewelry in which diamonds are set, except for patterns. The chief retail trade is that of New York, which is followed, in the order named, by Boston, Philadelphia, Chicago and St. Louis. A leading demand in the West is for large, fine diamonds.

The preference of the wealthy in Europe for precious fancy stones—such as rubies, sapphires, emeralds, cat's eyes—over diamonds, gives signs of being followed here by persons of wealth, purchases being, of course, confined to veritable gems. A perfect, fine, pigeon-blood ruby is, indeed, more valuable than a diamond of the same weight. Star sapphires, distinctly fine, are extremely rare; so also are Egyptian turquoise. Fancy stones generally, fine and well proportioned, are by no means abundant.

Goods for the Holiday Trade.

THE INDICATIONS are that the holiday campaign is going to be "short, sharp, and decisive." Usually it has commenced earlier than this, and extended over a period of about three months. While some of the larger or more distant dealers have already sent in their orders, the bulk of the holiday trade is yet to come, and three months' work will, consequently, be crowded into about one-half that time. This makes it hard on the manufacturers, and cannot but result in considerable disappointment to dealers who delay their orders till the last minute of the last hour of the last day. As a matter of fact, stocks in the hands of manufacturers are comparatively low. They are chary of making up large quantities of new styles of goods until they have felt the pulse of the trade and ascertained how they will take. If they prove to be popular, they need some time in which to make them up. For some time past many of the factories have been running on half time, waiting for indications from the trade as to the quality and kind of goods that would be required. When the orders begin to come in freely, the goods to fill them will not be ready. Then comes delay in shipment, and the dealers grow furious because the goods ordered do not reach them, while Christmas approaches with undeviating promptness. At the holiday season all lines of trade are unusually active, and the transportation companies are crowded with freight of all kinds. This furnishes another cause for delay in getting goods to customers. Certain classes of goods handled by jewelers are extremely bulky, and should be sent as freight, which takes longer and costs less than when sent by express. But when dealers send in their orders late, there is delay in getting the goods, so that when they are ready to ship there is not time to send them as freight, so they must go by express, adding to their cost and overcrowding the express companies. Orders for silver-plated ware are usually the last made up by the dealers, and manufacturers have annually made their complaints without avail. Last year many orders remained unfilled because it was impossible for the goods to reach their destination before the holidays, so the manufacturers withheld them. There is no necessity for there being this crowding and confusion at holiday time. Dealers can just as well file their orders earlier if they will but think ahead a little. We advise all who have not yet done so to do it at once. If they do not, the chances are that they will be disappointed in their holiday stock.

WE ARE gratified to learn from numerous sources that the recent publicity given in our columns to the growing abuses of the memorandum system has awakened in the trade the thoughtful interest its importance deserves.

The embarrassing demands of unthinking men involved in the growing abuse of this privilege, is a subject of urgent interest—alike important to the wholesale dealer and retailer. The former feels keenly these burdensome exactions, while the interests of the latter are not subserved by methods which tend to foster outside competition.

Retailers justly protest against the encouragement of the outsiders who have of late become so formidable in the trade—but no one

thing lent greater ease to their recognition than the contrast between clean sales for prompt payment and the canal-boat system of memorandum. Peddlers, with potent cash and an eagerness to purchase, sought recognition in the trade, and the manufacturers and jobbers took them adulterously to their arms, only when long-taxed patience was forced to welcome any change that promised relief from a burdensome imposition.

Moreover, the present competition in business is keen and spirited. The cost of manufacture of staple goods is reduced to a minimum, and profits are correspondingly small. Therefore any added expense that enters into the cost of marketing goods must necessarily fall upon the dealer who relies upon methods of business which creates this additional cost.

When a prominent retailer comes to the counter of the jobber, not to buy, but to select an indefinite amount of goods on memorandum "to take home and decide at leisure what *not* to keep," his place at the counter is acceptably filled by the prompt and business-like merchant who knows what he wants and buys it quickly. It is the abuse of the memorandum privileges that is protested against rather than the practice itself.

COMMON JUSTICE and abuses which have passed into a byword alike demand that the present loose system of jurisprudence in connection with bankruptcy should either be so amended as to insure equal justice to creditors, or abolished altogether and a new law substituted in its stead. The recent failures in the woolen trade in this city have again demonstrated the urgent necessity for a new bankrupt law. The mercantile honor and character of the city have alike been compromised by the exhibition of such preferences as have been made in recent instances. The bankruptcy laws as at present existing in this and other states are a travesty upon justice of the most pernicious kind. Preferences should be regulated by law, not by individual favor, and it is for the good name of the mercantile community, as well as the protection of honest trade that a new and equitable law should be framed and passed. There is no lack of precedent or example. The philosophy of a bankrupt act is well defined, and its proper provisions plain sailing to a competent jurist. What the law requires is an accountant-general, whose duty it would be to supervise the workings of a well constructed act. When a business man finds it necessary to call a meeting of his creditors, or make an assignment, a proper court should alone possess the power to name the accountant or trustee upon his estate. From the moment he is declared a bankrupt, he should be a *nulla persona* in connection with the settlement of his own affairs except as an auxiliary to the trustee upon his sequestered estate. That trustee, by and with the consent of the creditors, and subject to the supervision of the accountant-general, and the jurisdiction of the proper court, should alone have power to adjudicate upon the estate, and declare the bankrupt entitled, or the reverse, to his discharge. A bankrupt law framed upon those or other equally equitable principles would be the saving of our mercantile honor.

THE EFFORT of our Government to obtain the co-operation of foreign Governments in the adoption of a common time unit applicable throughout the world has met with considerable favor. Previous to the assembling of the proposed International Congress to discuss the subject, our Government sent circulars inviting the opinions of all foreign Governments. To this circular favorable replies have already been received from upward of twenty nations, but, as yet, none of the great maritime powers have replied to the circular. It is believed, however, that all the nations of the world will soon send favorable replies, and that this important addenda to science and navigation will become an established fact.

MANUFACTURERS and jobbers must not look for any extraordinary rush of business this fall outside of the holiday trade. Retail dealers are shaping their business in a manner better calculated to make a steady demand for goods throughout the year than for spasmodic rushes, covering a few weeks only. That the trade of the year will be good there is every reason to believe, but what the volume will be cannot be told till the books are closed and the accounts made up. That the profits will foot up as large as in some previous years is not to be expected, for competition is great and the cutting of prices liberally indulged in. Up to this time the trade has reason to congratulate itself on the even tenor of business, on its exemption from disastrous failures, and for the generally healthy tone that pervades it.

The Jewelers' League.

President, GILBERT T. WOLOM Of Woglom & Miller.
 First Vice-President, JAMES P. SNOW Of G. & S. Owen & Co.
 Second Vice-President, HENRY HAYES Of Wheeler, Parsons & Hayes.
 Third Vice-President, WM. C. KIMBALL Of H. F. Barrows & Co.
 Fourth Vice-President, AUG. KURTZBORN Of L. Bauman Jewelry Co. St. Louis, Mo.
 Secretary and Treasurer, WILLIAM L. SEXTON Of Sexton & Cole.

EXECUTIVE COMMITTEE.

JOHN D. LYON, Chairman Of Lyon & Hardy.
 JOSEPH B. BOWDEN Of J. B. Bowden & Co.
 JAMES D. YERRINGTON Of J. D. Yerrington & Co.
 ROBERT A. JOHNSON Of Colby & Johnson.
 SAMUEL W. SAXTON Of Saxton, Smith & Co.
 CLEMENT B. BISHOP Of Carrow, Bishop & Co.

EXAMINING FINANCE COMMITTEE.

CHARLES G. LEWIS Of Randel, Baremore & Billings.
 CHAS. G. ALFORD Of C. G. Alford & Co.
 GEORGE R. HOWE Of Carter, Sloan & Co.

THE JEWELERS' CIRCULAR is the exclusive official paper of the Jewelers' League, and has been selected for the publication of all matters of interest pertaining thereto. Letters or inquiries pertinent to its business or purposes, and which might interest the trade or inquirers, will herein be answered. Address *Jewelers' League, Box 3,444, P. O., New York*, or the office of THE CIRCULAR.

The usual monthly meeting of the Executive Committee was held at the headquarters of the League, Friday evening, October 5th, Vice-President Kimball, Secretary Sexton, Chairman Lyon, Committeemen Johnson, Saxton, Yerrington, Bowden, and League Surgeon Dr. Wilbur, being promptly in attendance. The Treasurer reported a balance of \$3,427.45 in the general fund, and \$4,768.70 in the benefit fund, assessment No. 21 not being at that time closed. One delinquent member was reinstated after investigation; five requests were granted for change of beneficiaries; 73 applications were carefully examined, of which 20 were referred for investigation of obscure details, five were rejected, and the following 48 were accepted:

S. E. Theus, J. M. Stevenson, W. Simpson, G. Silberberg, W. F. Renziehausen, J. C. Phillips, B. Mannheimer, M. Magsamen, J. M. Lyon, S. H. Levy, H. Klees, I. Harrison, M. Daniel, B. S. Clark, E. M. Bracher, J. H. Isham, New York City; C. F. C. Bickelmann, Haverstraw, N. Y.; A. J. Gardner, Waterville, N. Y.; J. Vender, Brooklyn, N. Y.; E. Levit, W. G. Rattray, Chicago, Ill.; H. H. Fleming, Danville, Ill.; W. H. Harter, Steubenville, Ohio; A. Steinau, F. Frank, Cincinnati, Ohio; F. W. Platt, Delaware, Ohio; J. Frame, Toledo, Ohio; J. Hagerty, W. H. N. Pratt, Providence, R. I.; G. H. Ford, New Haven, Conn.; R. H. Rogers, C. May, Boston, Mass.; E. F. Ballou, Marlboro, Mass.; P. J. Girardit, Nebraska City, Neb.; T. W. Pack, St. Joseph, Mo.; C. B. Norton, Atchison, Kans.; P. F. Egan, St. Paul, Minn.; G. Deimel, Hancock, Mich.; H. A. Dow, Newport, Ky.; W. P. Thomson, Philadelphia, Pa.; H. Yoste, Vicksburg, Miss.; M. Hendry, Luling, Tex.; C. Becker, Newark, N. J.; L. L. Kachlein, LaFayette, Ind.; O. B. Blachley, Cedar Rapids, Iowa; J. H. Koch, Savannah, Ga.; P. P. Camp, Waupaca, Wis.; J. P. do Prado, Paris, France, making a total membership of 2,839.

Proof of the death of L. A. Cuppia was brought before the Committee, and the assessment therefor will be ordered at the November meeting.

Out of 2,800 members assessed on order No. 20, dated July 6th, but two members were dropped from the roll for failure to respond.

The success and standing of the League among its fellow societies has, in a large measure, been secured by its conservative management; in no respect has this been more apparent than in the modesty of its statements, with reference to itself and its probabilities, and by the absence of such blatant, specious statements as have been set forth by the "scalping" insurance concerns which pose as mutual benefit societies, such as are springing up and growing like mushrooms in our community. In striking contrast with the deceptive statements of facts and the illogical deductions therefrom, made by these ghouls, these traders upon the expectancies of widows and orphans, are the warnings sent out to the members of the League in its assessment notice No. 20.

"It is seven months since the last assessment was ordered, a record which is probably unprecedented in the experience of any similar association in its seventh year, and having so large a membership. *Members are cautioned not to be misled by the present immunity from death.*"

The circumspectness of the management is evidenced in the latter sentence, and THE JEWELERS' CIRCULAR, as the monitor of the interests of the members, would present some thoughts prompted by it. The benefits secured by membership in the League have been many fold their cost to the member, and thus it will be for several years; meanwhile the members feel that they are securing very cheap benefits, and such is the fact. In the course of a few years, when the assessments come more regularly, by reason of the increased mortality (but no more frequently than is equitable toward the member for the current benefit), he exclaims, "Phew! the assessments are coming pretty fast now," speaking, as one is apt to, more from contrast than from fact. Merchants are slow to appreciate a market value of \$50 for what they have been paying \$30; they are much more susceptible when a \$50 former value is being offered to them at \$30; but when the market value is fixed at \$50, and it is worth it and cannot be procured for less, we will pay it if we desire it, notwithstanding the unhappy retrospect that we formerly procured it for less money.

Every year during which the members are assessed less than \$50 each for the current year they should feel happy in the possession of a "bargain," by reason of their membership in the Jewelers' League. (Cut that out and stick it on the flap of your wallet).

Now, let us reason together. The experience of thirty American life insurance companies, from 1843, embracing over one million lives, shows that the deaths, by years of insurance, occurred as follows:

In	1st year,	63	out of every	10,000	exposed.
2d	"	81	"	"	"
3d	"	92	"	"	"
4th	"	100	"	"	"
5th	"	109	"	"	"
6th	"	113	"	"	"
7th	"	117	"	"	"
8th	"	122	"	"	"
9th	"	120	"	"	"
10th	"	123	"	"	"

An average of 104, or one and four hundredths of one per cent. per annum. Now suppose the same law obtains among persons entering each successive year, and that the same number of members are enrolled each year. In such case if the experience of one million of lives is enough to establish a law, the result will be:

In	1st year,	63	out of every	10,000	exposed.
2d	"	72	"	"	"
3d	"	79	"	"	"
4th	"	84	"	"	"
5th	"	89	"	"	"
6th	"	93	"	"	"
7th	"	96	"	"	"
8th	"	100	"	"	"
9th	"	102	"	"	"
10th	"	104	"	"	"

An average of 88, or 88 hundredths of 1 per cent. per annum.

Now, for convenience sake, instead of that call it 1 per cent. per annum, and apply it to the League. Its benefit being limited to \$5,000, whatever the membership may be in excess of 2,500, it is equivalent to the payment of \$2 each by 2,500 members; therefore, applying the percentage to that number would indicate a death rate of 25 per annum, and consequent assessments aggregating \$50 per member per annum. We repeat, therefore, that every year in which the assessments do not reach \$50 for each member, they will have had their benefit at a merely nominal rate.

It has been instructive to note the influx of members which occurs within a month or two of the death of a member in any certain locality, or perhaps in a store where there are a number of employés. There are very many men habitually putting off and always intending to become members, and not until death places his hand on a neighbor, friend, fellow clerk or shopmate, do they fully rouse themselves to the situation. When they learn of a check for five thousand (\$5,000) dollars having been received within a few weeks of his death, by the widow or family of a deceased member, they begin to realize the good being accomplished in our trade by an institution which, since December, 1878, has paid promptly and without cavil, to jewelers' widows, orphans, sisters or mothers, over \$60,000. There is no boy's play about that.

Wherever there is a good name, well earned, there are those ready to avail themselves of its prestige in either presenting themselves to the public or in pretending to represent the institution whose name they surreptitiously use: In Pennsylvania towns, and latterly in Binghamton, N. Y., is a peripatetic party who expose over their door a red flag inscribed, "Jeweller's League—Sale of Watches, Jewellery, Noveltys, etc." (*sic*). Their handbills state, "The Jeweler's League consists of a number of the leading manufacturers of watches, jewelry, silverware, revolvers, albums and clocks, and importers of novelties, optical goods, etc., of New York and Providence, R. I., who have combined together under the firm name of the JEWELER'S LEAGUE, the object of which is to dispose of their surplus stock." "Recollect, we are a reliable firm." So glad! to have such an assurance. If the reputation of the Jeweler's League were as well known outside as it is within the limits of the jewelry and kindred trades, the use of its name in such a connection might lead the public to patronize such a concern.

The League, on October 16th, became re-incorporated under Chapter 175 of the Laws of 1883, to which reference was frequently made in this column during the agitation of its passage by the New York State Legislature. There has heretofore been no general law under which such societies as the League could, with unquestioned propriety, incorporate. Some societies have incorporated under the act for the incorporation of charitable, benevolent, religious and missionary societies; while others, organized for the same purpose, with a curiously contrasting inconsistency, have incorporated under the act for the incorporation of sporting clubs, yacht, base-ball and pleasure clubs. All societies like the League are placed upon a better foundation by incorporating under this act. One of its wise provisions is, § 19:

"The money or other benefit, charity, relief or aid to be paid, provided or rendered by any corporation, association or society, authorized to do business under this act, shall be exempt from execution, and shall not be liable to be seized, taken or appropriated, by any legal or equitable process, to pay any debt or liability of a member."

The act embodies all the features which experience has proven are essential to the welfare of these societies. If enforced by the insurance department, as it should be, in view of the thorough supervision provided for by that department, the evils to which close corporation concerns are liable, will be, to a great degree, if not wholly, avoided, while the system will be upon a sound basis. It effectually bars all such speculative societies as have brought disgrace upon our neighboring States, puts a wholesome restraint upon those who incline that way within our borders, and gives adequate protection

to actual mutual benefit societies. The President of the League was an active participant at Albany in the efforts which culminated in the passage of the law.

[Copyright Secured.]

The Cup—Its Art and Customs.

[BY JOHN W. MILES.]

Continued from page 274.

AFTER A feeble struggle against the disciplined army of Alexander, the vast Persian empire fell to pieces, and the fragments were ruled for several centuries by Greek sovereigns. But Persian art and customs were never entirely changed until the Mohammedan invasion of the 7th century introduced a new religion interdicting all representations of the human form. Even then an intermediate school devised the practice of representing forms of natural beings imperfectly; thus a bird would have the head of a woman, or a face would be minus an eye or one of the features. Regarding the use of wine, Mahomet at first permitted it, but, alarmed at the disorders which it caused, he forbade it absolutely. Nevertheless the Persians both publicly and privately indulged in wine drinking. In fact there was no party of pleasure in Persia wherein wine did not form a part served in cups of costly material and great variety of style. What could be more magnificent than Chardin's description of the king's "*Maison du vin*," at Ispahan. "It is a kind of apartment from thirty-six to forty-two feet high, raised two feet above the ground, built in the middle of a garden, its narrow entrance concealed by a little wall built in front two paces distant, so that what is going on within cannot be seen. Inside, to the left, is the officer's room or magazine, and to the right a large apartment. The saloon, which is covered with a dome, is in the form of a long square, extended to a Greek cross by means of two porticoes or arcades sixteen feet deep, which are at the sides. The middle of the apartment is decorated with a large basin of water with porphyry sides. The walls are overlaid with tablets of jasper all round eight feet high, and above, as far as the center of the dome, one sees on all sides nothing but niches of a thousand different forms filled with vases, cups and bowls of every kind of shape, make and material, as crystal, cornelian, agate, onyx, jasper, amber, coral, porcelain, precious stones, gold, silver, enamel, mixed one among the other, and which appear incrustated the length of the walls, and hold on so slightly they look as if falling from the dome. * * * * Among the sentences applied here and there upon the different walls of the hall I remarked this: 'Life is a successive intoxication, pleasure passes and headache remains.'"

However much Egyptian art may have been fettered and bound down by priestly law, it was undoubtedly the germ of that wonderful taste displayed by the Greeks, which we approach with a reverence not unmixed with awe. The Egyptian colony, under Inachus, who settled in Greece about two thousand years before the Christian era, unquestionably introduced not only the religion but also the arts and education of Egypt. But Greek art was developed under different circumstances. True, they had a complicated system of polytheism that became more extensive even than that of the Egyptians, but the inspiration derived therefrom was unrestricted. The various attributes, half human half divine, of their gods and goddesses, furnished a field for the exercise of fancy almost unlimited. The social customs of the Greeks also stimulated that desire for excellence and originality that culminated in a school invaluable to all succeeding ages, while the influence of the climate instilled in all classes and conditions of men a profound love for the beautiful. This last is ever the greatest possible incentive. The productions of Grecian genius were not confined to the few. The demand was universal, and the producer was forced to meet in every household refined and cultivated critics of his work. The Greek was a born artist, admiring art with all the passionate fervor of a lover, in which intellectu-

ality, in a literary sense, had no place. It became as necessary to his existence as food, no longer a luxury, but a want that must be gratified. Nor did he disdain to borrow themes of other nations, yet in such instances always modifying or perfecting them according to his own ideals, and, by this remodeling, establishing them as his own. It was this appreciation of the masses that gave such perfection to their work. It was the general taste that caused art to flourish, for art was clearly understood by the people of all ranks. We find in Greece, therefore, all the requisites for superiority in design, civilization, culture and popular taste, together with a religion peculiarly adapted to inspire grand and noble themes.

The wants of absolute necessity being supplied, the early Greeks sought to gratify that craving of the human mind for representation of whatever may be worshipped in spirit by some material form. At first rude stones were used as symbols of their divinities, then followed the head upon a pillar, then sex, the roundness of the thighs, the legs and feet, and, lastly, the arms and hands. These statues, however, possessed the stiff and lifeless character of Egyptian work, and the perfection that afterwards developed was due to the causes previously mentioned. Assured of appreciation, it became the ambition of the Greek artist to excel, not only in execution, but also in originality and expression. Did he desire to express the highest perfection of physical beauty? behold a Venus; did he wish to portray the most profound depths of mental grief and anguish? behold the expressive face of the Laocoon; or was his thought one of majesty, dignity and power? the Olympian Jupiter embodied the inspiration. It was his pleasure to depict every emotion of the human soul except fear. The Greek did not understand fear, and could not express what he himself could not feel. But in whatever form or material he wrought he evoked life and thought, and the intangible ethereal idea of his brain stood revealed to the world to "be read and known of all men." Hence he strove to make each separate production not only more perfect than the last, but also different from it in every possible way consistent with beauty. This cultivation was certain to receive its proper meed of honor, while, at the same time, it supplied a rich treasury of beautiful objects of which the Greeks were justly proud.

It was not until after the long war with the Persians that the Greeks became independent and rich. Before this the precious metals were so rare that King Philip of Macedon, being possessed of a golden goblet, habitually slept with it beneath his pillow in fear of robbery. The noble metals, as well as the art of working them, was derived

established the supremacy of Greek art. Artists, and especially sculptors, devoted themselves to the construction of vases, cups and the smaller pieces of gold and silver work for which they had such an abundance of material. The production of articles for the table, either for use or ornament, became thus closely allied to sculpture, and in nothing did they display more rich and expensive taste. As an example of the extreme delicacy of their workmanship, Pliny states that Theodorus of Samos made a brass statue of himself with three fingers of the left hand holding a model of a four-horse chariot so exceedingly minute that the whole piece, both chariot and charioteer, could be covered by the wings of a fly. The cups, especially, were of the rarest materials and wrought with all the brilliancy, delicacy and affluence of design of which art was capable. The *kulikeion* or cupboard of the Greek houses, as well as the sideboard, figure 7, were stored with goblets, cups and drinking utensils of different forms and materials, according to the taste and means of the master, but always, whatever the material, distinguished by elegance of outline, graceful beauty of form, and minute delicacy of finish. The Greeks were rather poets than gluttons, the pleasures of the appetite were secondary and subordinate to the pleasures of the soul, and hence the host took pride in not only serving the finest wines but also in supplying a diverse assortment of the most beautiful cups. Pythias of Phigaleia, when dying, ordered the following to be inscribed upon his tomb:

" Here jolly Pythias lies,
A right honest man and wise,
Who of goblets had a very great store:
Of amber, silver, gold,
All glorious to behold,
In number ne'er equalled before."

The number of drinking utensils must have been very great, and the people seem to have vied with each other in quantity as well as quality. Even after the fall of Greece Pompey is said to have been entertained, when on his expedition in the countries adjoining Judea, by one Ptolemaens, who provided for eight thousand horsemen at his own cost, and gave a feast to one thousand guests, setting before each a drinking cup of gold, which was changed at every course.

In the Greek mythology the cup occupied a prominent position, and Homer acquaints us with the favorite drinking cup of Achilles, upon which he set a great value, preserving it for his own particular use and for pouring out libations to Zeus alone. In a list of articles demanded as a ransom for the body of Hector was included a rare goblet, and a similar gift aided in alluring Alcmena from the path of virtue; but the most famous bowl of mythology was that of Hercules, for when he had quenched his thirst he could set it afloat, leap into it and sail to any part of the world. As to the cups and drinking bowls in actual use by the Greeks, they were certainly highly valued, and, as we have seen, made no inconsiderable figure among the household plate. They were bestowed as prizes in the gymnastic contests, assuming thus the sentiment of victory. Yet Greek art needed no external memory to increase its expression. The age was grandly poetic, supplying every object with more or less sentimentality, that told its own story without aid from either history or association. It is said that Helen of Troy, who was justly proud of her beautiful bosom, presented to one of the temples of Rhodes, as a votive offering, a goblet of electrum (gold alloyed with silver and believed to possess the property of detecting poison) exactly the size and shape of one of her breasts. This article certainly could not have lacked either poetry or sentiment. A very beautiful cup was obtained from Sidon. It had two handles, and was ornamented with small figures in relief. Drinking vases were also formed from the large horns of the Molossian and Pæonian oxen, rimmed with silver or gold, and copies of these were also made of pure silver or of massive gold, and sometimes with lids of the same metal. A very celebrated cup among the Athenians was the *Thericlean*. It was a species of deep chalice with two handles and bulging slightly at the sides. It was made of a certain black earthen ware, of wood and of gold, decorated with various paintings, with sometimes a simple wreath of



Greek Sideboard, Figure 7.

from the east. The Persians, who were rich in gold and silver, were compelled to part with large quantities to the victorious army of Alexander, and the gold of Greece, which had been barely sufficient for the smaller ornaments, received such enormous accessions that not only vases but also beds and thrones were made of the precious metals. Then began the production of those great masterpieces that

ivy immediately below the golden rim, and occasionally covered with representations of animals. Some cups also were wrought in fantastic shapes, such as shoes, legs, boats, heads of beasts, etc., the latter, (*Rhytons*, figure 8), having sometimes an orifice in the lower end through which the wine escaped and was caught in the mouth. Pliny



Greek Rhytons, Figure 8.

speaks of Antipater as the maker of a bowl decorated with a sleeping Satyr so artistically engraved as to appear thrown out in relief. Pytheas made a bowl embossed with the figures of Ulysses and Diomed stealing the Palladium from Troy, and the engravings of domestic life (cooking scenes, etc.) decorating his cups were so finely executed and so liable to injury that they could not be copied by any artist of his time. But perhaps the most curious examples were the *diatreta*. These were of cut glass or precious stones ground in such a manner that the patterns were not merely thrown out in relief but cut completely through, small pins or threads being left to hold the lace-like tracery to the more solid portions of the cup, figure 9. Some

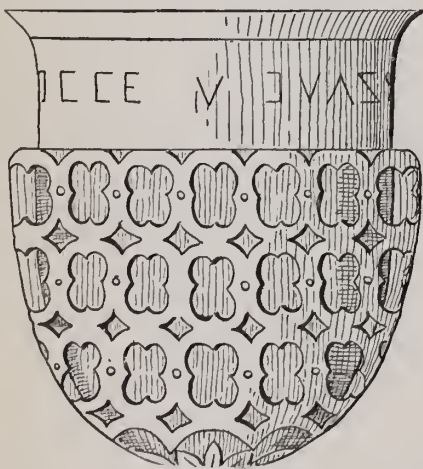

Greek Diatreta, Figure 9.

specimens of these are said to have been sent to Rome from Egypt by Hadrian. The inscription of the illustration, *Bibe vivas mollis annis*, is in projecting green letters, the color of the net is sky-blue and of the glass itself opal. It was found near Novara, and the colors described may have been, and probably were, caused by the chemical action which time seems to produce in all articles of glass long buried. Occasionally goblets of gold or silver were made of enormous size as offerings to some divinity. In these cases the workmanship would be so highly elaborate as to far exceed in cost the great weight of the precious material. Entire landscapes with numerous figures and objects were sometimes represented. Bacchanalian processions, with a multitude of satyrs and maenades, moving along some wooded valley or rocky shore at the heels of the

Seileni, or groups of nereids, nymphs and tritons sporting with the waves of ocean.

In ceramic art painting took the place of the chased or relief work of the metals, and a large proportion of our information regarding Greek customs is derived from these pictures delineated upon vases, etc. The cups sometimes had the "gorgonium" or Medusa's head in the interior, and on the exterior two large eyes near the handles. They also bore inscriptions inviting the guests to gaiety, such as "rejoice and empty me for the gods," or the Bacchic cry *Eva Evohe*, or "health and drink me," or "drink and lay not down," (the cup). For the decoration scenes were chosen from the symposium or from mythology, such as Ulysses and his companions making Polyphemus intoxicated and putting out his eye, and one *crater* or mixing-bowl represents the marriage of Thetis, where the goddess is seated in the interior of a Doric temple, before which is an altar surmounted with a *cantharus*. Then follows a procession of divinities attending the marriage, Jupiter, Juno, Ceres, Bacchus, etc. Although it was fashionable to possess gold or silver cups finely sculptured with historical or mythological subjects, they were also often highly ornamented with jewels, and always strict exponents of the prevailing taste in the highest forms of art.

In the field of design the Greeks were especially strong. The great book of nature ever before them was constantly studied in their search for beautiful objects, and often the most simple thing under the magic of their refined idealization developed into articles of exquisite taste. Thus the acanthus leaf, so repeatedly represented upon the capitals and vases, was never rendered absolutely true to nature, but modified and reconstructed it furnished a pure and elaborate ornamentation. So also the honeysuckle, which passed through the same process, and numerous other objects, which were everywhere at hand, supplied by a bounteous world. Drawing was always an important item in ancient art, and the Greeks, mindful of the beginning of things, carefully studied its principles and practice. This developed a remarkable accuracy in the eye and hand, improving as well the perceptions of the beautiful. It is said that Apelles once called upon Protogenes, and, not finding him at home, drew a line and departed. Protogenes, returning, exclaimed that his visitor must have been Apelles, since no other artist could have executed a line of such beauty, and, adding one of his own surpassing the first, left word that if Apelles should again call it should be shown to him. Upon a second visit Apelles was so chagrined to find himself beaten that he immediately drew a third line uniting the two first and excelling both in fineness, whereupon Protogenes acknowledged him as master. The extraordinary precision required in this competition could only have been acquired by the most careful attention to the art of drawing.

It is a matter of great regret and ever to be deplored that so few specimens of Grecian art remain to us. The intrinsic value of articles constructed of the noble metals has proven in the past too great a temptation to allow of their preservation. When the spirit of the Greek was broken by the struggle with Rome, and the barbarians found them an easy prey, large quantities of beautiful objects fell into unappreciative hands. Even since the age of Constantine the Lombards, Franks and Normans destroyed a great deal before they acquired the graces of culture. Nor can we attribute the destruction of these valuable works to war alone, since the early Christians themselves furiously destroyed all the vestiges of antiquity in revenge for the Pagan reaction attempted by Julian the Apostate. Still later Leo III. came to the throne of Constantinople. "A peasant from the mountains of Isauria, a hater of images, depending more on arms and ignorant of all the mystical theology of the day," he issued an edict against all statues and mythological representations. Thus arose that fanatical class, sworn enemies to the meagre remains of early art—the fatal sect of Iconoclasts. Then occurred the greatest contest the world has ever seen on a question of art. The Iconoclasts on one hand and the orthodox and artistic on the other, continued a struggle that, occasionally rising into sanguinary civil war,

lasted for 120 years. Even all these enemies have not succeeded in entirely destroying the records of Greek art, so prolific was the production, and though the number remaining can be easily counted, and though they have mainly been excavated from accidentally discovered burial places, they betray a perfection that has ever proved the highest standard. Perhaps the most valuable collection we have was thus discovered as late as 1869. Some German soldiers, digging a trench for rifle practice just outside the city of Hildesheim in Hanover, unearthed a quantity of old Roman silver plate, including examples of many of the styles of drinking cups used by the Greeks and copied from them by the Romans. How they came to be buried in their hiding place is a matter of mere conjecture, but it is sufficient that the archaeologists have established their authenticity, even if the artistic character of the articles themselves failed to prove their identity. Among the larger pieces of this important "find" is a *crater* or mixing-cup, figure 10, decorated with arabesque work of



Greek Crater, Figure 10.

vines, leaves, scrolls, cupids and sphinxes thrown out in delicate relief. There was also a *cantharus*—a cup having high loop handles



Greek Cantharus, Figure 11.

at the side and sacred to Bacchus. Figure 11 is a representation of it, decorated on the neck and lower body with a goat's skin, while the main portion of the cup bears the thyrus in pairs, alternating with scenic masks and other ornaments, all in bold relief. But per-



Greek Cylix, Figure 12.

haps the most beautiful article thus brought to light was a *cylix* or *palera*, figure 12. This clearly illustrates the pure and graceful out-

lines of Grecian design. A comparison with the Egyptian cup (figure 1) will plainly show the wide difference in art between the two nations. That keen appreciation of the beautiful that exercised such a prominent influence upon the Greek character caused them to adopt, at a very early stage, the oval form whenever possible. Thus we find in the ornamentation of the *cylix* a leaf coming to a point, certainly, but reaching it by lines more or less ovoid, and without the stiff angularity of Egyptian work of the same class. The interior of the *cylix*, figure 13, is embellished with a seated figure of Minerva,



Greek Cylix (interior), Figure 13.

helmeted and leaning upon her shield. This is in almost entire relief. A delicate frieze of Greek flower and scroll work runs around the concave sides. Mr. Pollen states that "such a bowl filled with wine, white or red, over the gilded sculpture would glow with a light not seen even in a topaz or carbuncle set upon foil; an effect well understood by goldsmiths and hosts who, whether Greek or Roman, loved to dazzle every sense of their guests."

(To be Continued.)

Repairing a Timepiece.

TRYING TO FIND OUT WHY A WATCH STOPPED.

[From the New York Times.]

"HERE IS YOUR watch," said a watchmaker to a *Times* reporter, as he tore off a small white tag from the ring of a well-worn silver watch and handed the timepiece to its owner. "If it breaks inside of a year you can bring it back and I will fix it for nothing. I don't think it will trouble you though for it was very thoroughly repaired by one of our best workmen." "I hope not," replied the reporter as he paid the jeweler \$3 and left the store with the watch ticking in his pocket. For nearly a week the watch was a model of regularity, recording the time even to the minute with the great, yellow-faced clock in the City Hall tower. One morning, however, when it was drawn from under his pillow, the reporter discovered to his dismay that the hands were pointing to the hour of 2 o'clock. It couldn't be afternoon so early in the day. He rubbed his eyes and looked at the dial again. Surely there must be some mistake about it. He examined the hands. They were stationary. He placed it to his ear. It was as silent as a clam. The watch had stopped inside of the first week, and in spite of the three-dollar charge and the year's guarantee. He shook it. A few feeble ticks responded to the jar. The stubby second hand moved slowly about one-quarter around its short circuit and then stopped as before. He pounded it on the bed and made some uncomplimentary remarks about the watchmaker. This evoked another semi-revolution, which was again succeeded by the same silence.

After breakfast the unfortunate owner stepped into the nearest watchmaker's, a seven-by-nine shop, in upper Broadway, and asked the proprietor what was the matter with the watch. The jeweler took the timepiece, pried open the inside cover with a small can-opener, and peered into the works. After a cursory examination he handed it back to the owner. "It needs cleaning," he said.

"Cleaning?" ejaculated the reporter in astonishment; "why I paid \$3 only last week for having it thoroughly cleaned."

"I can't help that," replied the jeweler; "you were very foolish to take such a watch to a second-class workman. The reason it don't run is because it's dirty. The pinions are covered with dust, and the oil is all gum. Leave it here and I will fix it for you in good shape. Call again on Saturday and it will be ready. It will only cost you \$2.50, and you will then have a watch you can be proud of."

Thoroughly disgusted with the watch and the man who had warranted it, the reporter declined the offer, pocketed his timepiece, and left the shop. A few doors below, on the same thoroughfare, a brazen watch with a pair of black hands pointing fixedly to 12.20 swings from a rusty iron bar. The reporter passed under this sign and entered another jewelry store. A fleshy person who was seated at a work bench facing the window, reached for the watch and proceeded to open it as one would open an oyster. Placing an eye-glass, which resembled a dice box, to his eye, he critically examined the movements. After taking observations from every position a watch can be held in, he ventured an opinion that the jewel which covers the escapement pinion was broken. "Yes," said he, after sundry punches in the vital regions of the works with a small steel instrument, such as dentists use, "the jewel is broken. Any man can see that with half an eye. I wonder the watch ran at all. Have you dropped it anywhere? No? Well, that's strange. Leave it with me and I will put in a new one. It will cost you only \$5, and call around some day next week. What name, please?" The name was not given and the watch was returned.

In the block below a tall street clock indicates the presence of another jewelry establishment, while large show cases filled with costly trinkets and a brilliant assortment of diamonds and watches in the front windows attested its claim as a fashionable emporium. The reporter went in there. A languid young man, with a drooping moustache the color of barley straw, took the watch, and after working his way into the movement, placed a small lorgnette to his eye and glanced over the assortment of wheels and pinions and springs which were so numerous and diversely disordered. He remarked: "Your watch is very badly out of repair. The escapement does not seem to be doing its work. The hair spring is too long. It has too much play. I will cut it off and shorten it." Here he reached for a small instrument to sever the spring, but the reporter interposed. "No," he exclaimed, as he rescued the timepiece; "don't cut the spring. I guess that is not what ails the thing for I paid \$3 for having it repaired and cleaned only last week, and it ran very nicely until this morning when it stopped."

"Oh, yes," interrupted the young man, "I see you dropped it and the spring was spread out by the jar. I will undertake to repair it thoroughly for \$4, so that you can rely on it. I will give you a guarantee, and if it breaks—"

The reporter did not remain to hear the rest of the sentence. The watch had all the guarantees it could stand. He had heard by this time so many different opinions upon the condition of the watch that he was determined to learn, if possible, what did ail it. A few blocks down the street another jeweler was found. After several shakes he applied the watch to his left ear and listened attentively. "I think," said he, with a shade of doubt in his voice, "that the mainspring is broken." He then opened the inside case and scrutinized the works carefully. "Yes," he continued, "the mainspring is evidently broken. You must have been very careless with the watch, and let it fall. No? Well, you have wound it up too tight. That often is as bad as a fall. I will put you in a new one for \$2." The offer was not accepted, and the reporter walked out of the shop with his dilapidated chronometer in his pocket, to the great disgust of the jeweler. At the next store a small, nervous man was examining a double row of fly-specked watches, suspended from a small iron rack in the window, and baking in the sun which filtered through the dusty window panes. He took the timepiece and, reaching into a drawer, pulled out a white tag and proceeded to tie it to the ring. "What name?" he asked. "No name," replied the

owner; "please tell me what is the matter with the watch." With an air of annoyance, the nervous man exposed the works and probed around the balance wheel with what appeared to the owner to be almost willful malice. "One of the pinions is bent, the escapement is out of balance, and it needs cleaning; \$3—call next Saturday." The owner protested, and the watch was returned.

Having had sufficient experience in Broadway he now visited the Bowery. A large gilt sign over a wide doorway and several suspended clocks and watches, also in gilt, betokened a "jewelry palace," and into it the reporter walked. "What is the matter with this watch?" he asked. The proprietor, an elderly man, took the timepiece, shook it, listened, opened it, gazed into it and shook his head. "Hiram!" he called to a curly-headed young man who was working at the rear end of the store, cleaning jewelry with a long brush and some white powder. The young man stepped to the counter. "Vat ish de madder mit dat vatch?" asked the proprietor. Hiram looked at the watch as one would regard a very sore thumb and shook his head without replying. "Moses!" called the old gentleman to a second young man, younger than Hiram, who came from behind the rear partition. "Moses," said he, "you dell de shentleman vat ish de madder mit his vatch." Moses looked at the poor, miserable timepiece with even more solemnity than his brother, and, after sundry lugubrious shakes of his head, responded: "De cap chewel ish owet of blace. It vash growded back of de esgagement. If you dry to make it run mitowet gitting it rebaired, you will ruin your vatch. I never saw a vatch as bad as dat. It vill only gost you \$5."

"I can't leave it to-day," responded the reporter.

"I vill gif you a fine job for \$4, for \$3, for \$2, for a dollar and a halluf; and I wouldn't do it von cent sheaper for my grantfadder."

But in spite of the liberality of the offer the reporter pocketed his watch and pursued his search for information. Many other stores were visited and many more jewelers were interviewed. There were 17 seen in all. Three attributed the stoppage to a broken mainspring, five said it was caused by dirt, three thought that broken jewels made the trouble, two diagnosed it as a case of bent pinions, and the remainder were divided in their opinions, varying from a disordered escapement to a broken tooth in a cog wheel. Finally, tired of watches and watchmakers, the reporter carried it to the jeweler who had originally repaired it. "There," said he, as he laid the timepiece on the velvet counter mat, "take this miserable, ailing watch. You may keep it or give it away, just as you please. It hasn't a whole wheel in it. The mainspring is broken, the escapement is out of sorts, it wasn't half cleaned, and it is entirely ruined. It will cost me a small fortune to have it repaired. I don't want it any more. It makes me tired to see it around. I'll buy a new dollar-and-a-half watch that I can take some comfort in."

The jeweler took the timepiece and retired into the workshop. In a few minutes he returned with a broad smile on his face.

"Here it is in perfect order. There is nothing the matter with it. You forgot to wind it up last night."

How Diamonds are Smuggled over the Canada Border.

CAPTAIN DONOHUE, the custom house officer at Ogdensburg, is reported by a *World* correspondent to have unearthed an extensive scheme of diamond smuggling on the Canada borders. The discovery was purely accidental, but the thorough manner in which the details of the case were worked out reflects great credit upon the federal officers. J. H. Clavering, a young farmer living near Kensingler Falls, early in September brought into Captain Donohue's office a small package of diamonds secured in a quill. He also brought with him a pigeon filled with bird shot, which he had killed that morning. On examining his prize the young man found attached to the left leg a small roll securely tied with silk. Investigation

showed this to be the large part of a turkey's feather filled with diamonds.

The officials were at first inclined to disbelieve the story. However, the pigeon lay there, and nine glittering stones were offered in proof of the farmer's assertions. The only expert jeweler in the city was sent for, and, after careful examination, pronounced the stones genuine diamonds. Seven of them were "first water," and the other two were of inferior grade. With difficulty a bird-fancier was secured, and he declared that the bird was a carrier or homing pigeon. The large white rings about the eyes, the extra-sized waddle and the breadth of wing proved the bird to be a "Red Antwerp," or of the finest breed raised.

Thoroughly convinced that such birds were used for smuggling diamonds from Canada into this State, Captain Donohue immediately set out to discover and arrest the smugglers. The farmer was unable to tell in which direction the bird was flying when shot, and there seemed absolutely no clue. The farmer knew of no homing pigeons kept in the vicinity of his place, and inquiry in the surrounding towns and villages failed to reveal any. Half a dozen men were sent out with Clavering. They distributed themselves about the country immediately surrounding Rensselaer Falls, and a week's careful watching and waiting was rewarded with the capture of two pigeons with their precious freight, but all efforts to follow the birds or to discover their destination signally failed.

Not disconcerted at this, the Captain went to work in another direction. All the trains crossing into Canada were carefully guarded. For several days there was no result, but on Sept. 22d his watchfulness was rewarded by the finding of a wicker basket containing four of the homing pigeons. The basket was addressed to a person at Kempville, Canada, and the charges upon it were prepaid. Two detectives were despatched on the train carrying the basket with instructions to follow up the party to whom the basket was addressed, learn the nature of his business, and secure evidence against him. The depot at Kempville is an old wooden structure, and the birds were put off at that place and stowed away in an outer shed with but little food. For five days the detectives waited in vain for the consignee to claim his property, and then reporting that the smugglers had evidently taken alarm, the officers were ordered back to this place.

Meanwhile the search for the hiding place of the adventurous law-breakers went on about Rensselaer Falls. The bills of lading and the express companies' receipts for freight transported over the Rome, Watertown and Ogdensburg Railroad, and over all other roads centering here were searched for a year back. One important point was thus established. Shipments of "fowl" were found to have taken place regularly from Henvelton, Richville, DeKalb Junction and Rensselaer Falls. Two consignments of pigeons from Richville were also traced up. One of these bore date October 16, 1882, and the other May 7 of this year. With these facts in his possession, Captain Donohue concluded that as three of the points of shipment were in DeKalb County, the smugglers' home must be in or near these, and the surrounding marshes and dense woods were thoroughly scoured.

A few weeks since, William Cowan, a trained woodsman, by the merest accident, as he admits, came upon the hiding place for which he had been searching. He had paddled down the Oswegatchie river in a boat, and about the middle of DeKalb county struck a marshy ditch that led toward Beaver Creek. Poling his way through the tangled roots and grasses, and wading part of the distance, his patience was rewarded by the rustle of wings and a soft cooing. Parting the reeds he saw within a clearing in the woods a number of pigeons. He felt his task to be practically accomplished, and, wading to firmer ground, soon came upon three dove-cotes securely fastened in the branches of as many dead trees. A rude log cabin in the center of the clearing was the only sign of human habitation. A knock at the door, followed by a loud halloo, brought no response, and, entering unbidden, Cowan carefully inspected the premises. There was little to see. A folding bedstead, a table, two chairs, a

charcoal furnace and a bench completed the furniture. In the table drawer pen and ink and paper and envelopes were found. There was no clue as to who lived there, how long the resident had been absent, or what his purpose was in selecting so out-of-the-way a spot for his home. Outside several bushels of shelled corn and a bag half filled with mixed wheat and oats lay on the ground where the pigeons could easily get at them. The birds were very tame, and the intruder had little difficulty in capturing a pair.

No attempt at tilling the ground had been made, and though the cabin bore evidences of having been built a number of years ago, no provision had been made for the support of the hermit who selected so secluded a spot for a home. Half a barrel of hard crackers and a mouldy section of dried beef showed that the strange marsh-dweller possessed a material appetite. A pile of empty cans back of the house also bore silent testimony to this fact.

Thorough investigation of the premises convinced Cowan that the smugglers had taken alarm from the failure of the three captured pigeons to return. The ingenious contrabandists evidently had a system of acknowledging the arrival of the birds, and when three were lost they knew that their scheme had been thwarted, so the cabin was abandoned, and a place of greater security sought.

Returning to this place, Cowan laid the result of his work before Captain Donohue, and that official determined to lay the matter before the Secretary of the Treasury at Washington, and a statement embodying the facts as herein given was prepared for transmission to Secretary Folger.

It is believed here that the frauds have been carried on for the past two years, as the pigeons, in order to be thoroughly trained to return home, must be raised on the premises. The scheme, as understood here, was to despatch about once every week or ten days a covey of twelve or fifteen pigeons loaded with diamonds. The precious stones were accurately described and a record of their shipment and reception carefully kept. In this way there was almost an utter absence of risk of detection, and as the birds fly very high and in a straight line home, the chances of being shot were exceedingly small.

Practical Treatise on the Adjustment of a Four-Jewel Cylinder Watch.

[FIRST-PRIZE ESSAY BY HERMANN HERRMANN.]

Continued from Page 294.

CHAPTER VII.

THE CORRECTING OF THE BARREL.

64. The clickwork having been finished, the barrel is subjected to a close examination; its pivots are examined first, and, if necessary, they are polished. This is done by fastening the spring arbor in a fusee turning arbor, when it is ground in the turning tool with an iron grinding file in brass bearings, similar as those used for the polishing of the center wheel pivots, and polishing them with rouge or diamantine and composition file. The previously described pivot polishing files (art. 34), can be used to great advantage. It is almost needless to explain that the pivots must be almost cylindrical.

65. Examination is directed next to see whether the barrel runs exactly true both over face and height, and try the width of the pivot holes. If the barrel runs untrue over the face, in case the holes are good, it may very often be corrected by shifting the cover, and if this cannot be done, then by stretching the cover rim at the place where the barrel is highest. A cover which springs in only with difficulty can be remedied by filing off a little upon the opposite side of the cover, in such a manner, however, that the rim is not unfitted for springing in. The stretching of the cover is permitted only when it is not turned out. If it can be turned, it is unconditionally necessary to mark the place in the barrel by small dots, where the notch of the cover is situated at present, and to drill a pin in the bezel, which is even with the surface of the cover. Again,

attention must be paid to that the bezel in the barrel is sufficiently turned in, and also that the cover rim is sufficiently bevel either by turning or filing, so that the cover cannot be forced out by any accidental tremblings of the mainspring. If the bezel in the barrel is not good, it is carefully to be corrected upon a universal tool by means of a suitable somewhat bevel graver.

66. For investigating the barrel, the spring arbor, so as not to injure the winding square, is fastened into the tongs of a screw head polishing machine, or else the spring arbor is at once left in the fusee turning arbor. If a barrel runs untrue over its height, it is best to bush the two holes. This may be done in a very practical manner as follows:

67. Take a disc of hard wood, which has already been used for the purpose, of about twice the size and thickness of an 18-line watch plate, fasten it in the universal tool, and turn a sink in it, into which the toothed circumference of the barrel enters firmly. Then spring in the barrel without taking the wood plate out of the tool, and open the upper hole to a size fitting for a bouchon. The cover is next sprung in place, and also the upper hole is opened for a bouchon.

68. The barrel is next removed out of the plate, without removing the latter out of the clamps, and the holes are opened a little with a broach. It is advisable, as also in the case of bushing the center wheel holes, to file small cuts around the rim, by which the bouchons can be fastened more securely (art. 39). The bouchons are to be turned accordingly, or already previously prepared ones are to be used and riveted, but the holes are always to be left a little smaller.

69. Any skillful workman would now know how to make the barrel run true by broaching the holes. In order to go very securely, however, they are turned in the universal tool, as above described, until they are almost suitable, after which they are made correct size with broach. A barrel revolving exactly true over its height as well as face is obtained in this manner.

70. Next the shake between the barrel and the case would have to be corrected, and the latter is screwed upon the spring arbor for purposes of examination. If the barrel has too little shake, sufficient metal is turned away, similar as by bushing the center wheel holes, by fastening the barrel with its tooth rim between the clamps of the universal tool.

Matters are of a graver aspect if the barrel has too much shake, because in this case the upper shoulder of the spring arbor is to be corrected by turning. For this purpose the upper square of the spring arbor is fastened in a fusee turning arbor, while the lower pivot runs in an appropriate hole of the counter center, when it may be turned with ease. The cores of fine watches should never be turned under, in order to contract the shake. It is necessary to polish the core upon both sides, or at least to grind them flat, in order to lessen the friction occurring here.

71. The spring core should be equal to one-third of the barrel diameter, and, should it be essentially smaller, it is to be replaced by a larger one. Too large a core is turned down somewhat, and it is made according to the shape in the cut, whereby the danger of a bursting of the spring is materially lessened.

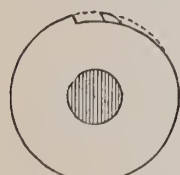

FIG. 7.

It is barely worth while to mention that the hook of the core must be as low as is indispensably necessary, in order to decrease the danger of bursting the spring as much as possible; it suffices to make the height of the hook barely beyond the thickness of a spring blade, and it should not be omitted to make a small notch in it with a three-cornered or fine screw-cut file.

72. Unduly thick sides of the barrel are always to be reduced by being turned down, so as to obtain as much room as possible for a good-sized spring. The space to be occupied by the unwound spring is not more than one-third of the inner barrel diameter, or one-sixth upon either side, which is to be occupied by about 13 or 14 coils, if it is to be of a correct size and thickness.

73. In order to make the motion of the spring a thoroughly free one, the hook on the core as well as in the barrel must be in the middle of the space destined for the spring. Also the holes in the spring must not be located to one side—that is, outside of the middle of the breadth of the spring; in this case, the inner hole is filed larger with a fine square file, and this is to be done in such a manner that the hook in the core will catch in the middle of the hole. If the outer hole of the spring is bad, it is broken off, the spring end is slightly heated, and a suitable square hole is made with the spring hole tongs. After glow-heating, the spring is ground white again, which can be done with an emery wood or oilstone.

74. Should the hook in the barrel not be serviceable, it can be replaced with ease. A hole is bored in the middle of the barrel, of about No. 15 of Latard's screw plate, in a direction opposed to the coils of the spring, and a thread is cut in the same direction; the same number of thread is afterward cut upon a brass pin, which is fitted in and shortened to a correct length; it also must protrude not much beyond the thickness of the spring blade. After it has been sufficiently notched in, it is screwed in firm, and the superfluous end is cut off with the screw-head file or nippers. It only remains to file away the protruding end upon the outer rim with a Barrett file, so that no burr enters into the teeth.



FIG. 8.

It is rather more tedious to screw in the spring hook from within the barrel; but this little additional trouble is well worth the pains, because a hook thus put in can never be pressed out by a bursting of the spring.

75. We next have only to investigate the shake of the barrel with open cover and to correct it. Particular attention is to be paid to that the square for the male stop protrudes sufficiently, so that this do not rub upon the cover, and if the cover is thick enough, it must be turned out a little.

When the barrel is so far attended to, the stopwork is next taken in hand.

CHAPTER VIII.

THE STOPWORK.

76. The stopwork generally found in Swiss watches is the so-called Maltese cross stopwork. It is first examined whether stop and cross suit to each other, and it is inspected by slowly driving the stop and always pressing the cross away from it.

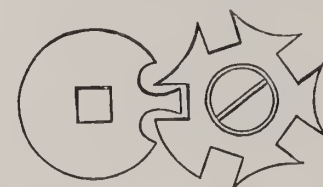

FIG. 9.

77. If the stop is too short, or if the whole body is too small generally, it will, in place of gearing over the tooth point of the cross, seize into the rounding (see fig. B of cut 10). This defect is corrected by replacing one of the two parts (generally the cross).

78. Before throwing out a part, however, scrutiny is directed toward ascertaining which is better—whether either the cross or the stop should be replaced, and this depends upon the exactitude of the cross or of the stop, and, finally, upon the proportions of both from each other.

79. To be thrown out in all cases is a star

1. Which is not truly round, and induces errors thereby.
2. Which is too thin, so that it does not offer sufficient resistance in winding, and by which the stop can either pass above or below the cross.
3. The screw countersinking of which is turned out too deep, in consequence of which a regular notch is formed in the collet, and due to the bracing against by winding.
4. With too large a hole, whereby the action of the stopwork is rendered faulty and insecure.

80. A small stop must be replaced if

1. The square hole in it is too large.
2. If it is too small in circumference.

3. If the notch for the fastening pin upon both sides reaches beyond the one-half of the thickness of the tooth to the rim, whereby the cross catches with its points, fig. C. This may frequently be corrected by grinding a bevel on the stop at both sides, down to the depth of the cut, whereby a hanging is rendered impossible.

4. The most frequently occurring defect that the stop is hollowed out too much, fig. D.

5. If the stop is too thin; and

6. If it is too short.

A stopwork is represented in fig. A with stop, the hollows of which are too small, so that the points of the cross brace in it. The sharp cross points must always be shortened somewhat, and carefully rounded off, otherwise they would brace in the least inequalities of the tooth rim.

81. If only the stop is to be replaced, in order to regulate the stopwork, a suitable one is to be picked out, rather a trifle too large. The searching is essentially facilitated by using the old one as pattern.

82. It is good to heat the corresponding stop upon charcoal to a cherry-red heat before using it, and to let it cool slowly, as the steel can be worked to more advantage.

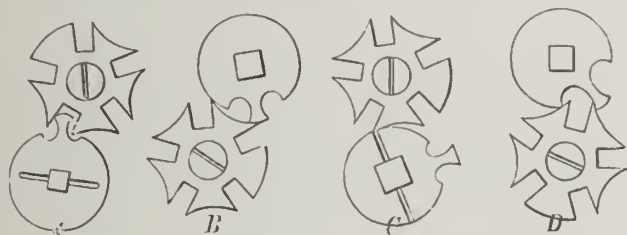

FIG. 10.

83. The hole is first to be worked. This is done by fastening the stop in a sliding tongs, and enlarging the hole uniformly toward all four sides with a square file. This must be done very carefully, however, not to displace it out of the center. When the square hole is nearly appropriate, it is completed by driving in an exact square punch. A nice square is formed hereby, especially if the punch was nice and square. The burr created by this driving in is removed with a file.

84. When the stop has been fastened firmly upon the square, its size is examined, whether it passes free or still pinches in the roundings of the cross. This latter defect is remedied by placing the stop upon a square turning arbor, and turning it to size upon a turning tool, and then grinding it together with the cross. The stop is then finished by itself.

It frequently occurs that the hollow is made too open and broad (fig. D), which is most generally due to the thick round files used for the purpose. Much attention must be bestowed upon doing this piece of work.

85. When the stop now fits firmly upon the square, continue your examinations, whether it passes freely, or whether it pinches in the sink of the cover.

The actual male stop must not be filed too weak, whereby it loses in good appearance together with its capacity for resistance.

The two hollows of the stop must be perfectly round and smooth, so that a setting of the tooth points becomes impossible. The correct length of the stop is easily ascertained by driving the stopwork and pressing the cross away from the stop; the stop must then securely gear into the point of the tooth; and in the other case, that by passing through the tooth point presses against the stop, it must not brace against this. It has been found to be of advantage to make the stop flat in front.

(To be Continued.)

Review of Modern Art Taste.

WHEN THE first London Exposition, of 1851, which is fully entitled to the honor of having opened a new epoch in the art history of the world, united the industries of nations, all the defects

of a general taste and want of originality became at once glaringly perceptible, and the fact that during the last two centuries, by force of a sickly grasping and chasing after styles, true art taste had altogether been lost sight of, became painfully apparent. Never before in the history of nations had there been such a gathering of their most meritorious works, or such an opportunity for comparing their so-called "styles," but, after surveying them, the only verdict that could be rendered, alas, was that the laws of colors were disregarded, styles were simply a humdrum, void of characteristics, and mere imitations, and confused and mixed. The appreciation of the beautiful, even, was lost—effect was mistaken for beauty. A few articles of true artistic conception could not ameliorate or influence the general verdict; indeed, they simply aided in opening the eyes of Europe to more strikingly perceive the all-pervading vagaries of taste. Happily, the Orient, uncultivated and uncivilized though it was called, came to the assistance of Europe, to help it to once more regain the true paths of art.

There were perhaps many individuals, but there was only one nation, as such, which was ready to profit by the example—the English. They were wise enough to perceive that the French, on account of their versatility and routine, excelled them in matters of taste, while sharing in the general defects of style. The only question was to find their way back, and, after having found it, to gain so much vantage that by the time other nations should awaken from their lethargic state, they should be far in the lead. Capable instructors were engaged in France to teach, while the English were ready to learn, and incorporated with their art industry all those branches in which the French excelled. Drawing schools were opened all over the island, and united with the industrial schools. But these efforts would not suffice, of themselves, to instil new ideas; they would simply lead to a worse confusion by blending the English style with the French. The great problem to be solved was where and how could the principles of pure taste and applied beauty be studied. It would be futile to compel the whole world to accept one standard style. Each one had its preferences and peculiarities; for instance, the merits of one consisted in the treatment of the relief; those of the second, in the grouping of its coloration; of the third, in the manner in which natural forms were converted into artistic ones. It was not necessary to either blend all these styles into one, or to throw them aside altogether. The question simply occurred on re-acquiring the lost principles of art.

These logical conclusions led to the founding of a museum for art industry—the South Kensington Museum, the creation of which is solely due to the experiences gathered at the first Great World's Fair, and it stands now unrivalled and famed throughout all lands. Its avowed purpose was to serve both the artist and the public, because it is an incontrovertible fact that both the public and the artist must be educated together—the latter is an emanation of the former; he teaches them by innately comprehending their individual ideas of beauty and art, and embodying them in his productions. But his ideas, expressed in the tangible form of shape or verse, are simply the unexpressed ones of the public. Where there is no education, even if only in one direction, there can be no art.

England was not content with these efforts. Other schools were opened, teaching all the branches of industrial art, in every hamlet, village and town; lectures were delivered, and this programme was adhered to with the universally known English obstinacy, until success has crowned its efforts, and it has given an example to the world what the human will can achieve, if united. Only eleven years after the first lesson of humility learned in 1851, at the second exhibition of 1862, the extraordinary advances of England were plainly perceptible, and it could with full honor enter into the lists of rivalry with France. To-day (1883), England distances France in several branches. It is well known that the former sends goods to a large amount to the latter.

But England did not remain without imitators. Austria was next to recognize its own inferiority, and sought to retrieve its condition

by organizing schools and museums of art in all possible branches throughout the empire. Germany, with its wealth of princes and poverty of people, stood aloof for a while, but when it threw itself into the vortex of renovation and restoration, it engaged with hand and heart in the task, and it can be well called to-day one of the foremost countries of the age. Collections, museums and schools of art were established everywhere, and several of the old-fogy institutions changed to correspond with the progress of the age.

On the heels of Germany followed Russia, Denmark, Sweden, Norway, Holland, Italy, and the United States; some with greater, others with less enthusiasm. But France, the victorious, which once towered so triumphantly above all other nations and dictated commands? Also France is following in the wake. Its first, but unsuccessful struggle for the establishment of an art museum dates to 1867—but, alas, the political vagaries of 1792, which resulted so beneficially to all other nations, in causing the downfall of all the cobwebbed, obsolete feudal traditions, appears to hang like a pall over this country. It is true that at the Paris Exposition of 1878, France still maintained its rank as a leading State of art industry, but the broad gulf that formerly divided it from the rest of the world was no longer visible, and it appeared rather to be somewhat superior in taste and style, but it no longer stood as the sole and exclusive leader of both. England and Austria showed more really artistic merits than France. French taste had frequently borrowed from foreign ideas, and complied with foreign exactions, and changed about one-half of its intrinsically French style into a foreign one—a thing which would have been unheard of even during the Second Empire. Foreign competing nations were forced to contend with all the odds against the French—France possessed its great body of artists, artisans, and skilled workmen, educated in all the traditions of two centuries, while foreign nations had been compelled to educate and create all these forces within the past twenty-five years.

This is the standpoint which we occupy to-day in the wide domain of art, in which every muscle and fiber is exerted to press forward. Museums and schools, scientists and artists, as well as statesmen, have made the question of art industry a universal one; they have made it a contingent of our culture, of benefit to the national commonwealth, of public and private life, of the State, and domestic circle. Every man is busily engaged in organizing, creating, working, vieing, and rivaling. We do not know what the future may have in store; but we are imbued with the full conviction that the seed sown to-day, with intelligence and discrimination, will not bring tares. The desire for culture and art of the second half of the nineteenth century is pursuing good paths, which will lead it to a desirable goal.

Depthing Tool for the Angular Depthings of Stemwinders.

[By M. GOUTARD, in *Revue Chronométrique*.]

STEMWINDING watches are daily becoming more universal, thus creating the necessity for the repairing watchmaker to have a depthing tool that enables him to regulate the conical depthing with all precision.

Two difficulties were to be avoided: its complication and an immoderately high price; we believe that the tool of Mr. Goutard will answer to both demands.

In the first model the inventor suppressed the joint of the ordinary tool, and caused the two halves of the circle to move perpendicularly one to the other; but the arrangement became too complicated thereby, and the modification, hereby annexed in the cut, was more suitable.

The main body of the apparatus is a depthing tool, such as is found in all material stores, and the new accessories, parts which we will describe in detail, are enclosed in the space described by the letters *t b v b*.

A triangular plate or solid support (*e*) is fastened by two screws to

the right side of the tool. The tube or canon *a m*, is fitted to its apex in such a manner that it forms one body with it. At the extremity *m* of this tube is adjusted a nut with incision *e n*, which turns freely in *m*, but without advancing or receding. This nut, flat above, is provided throughout its interior with a screw thread.

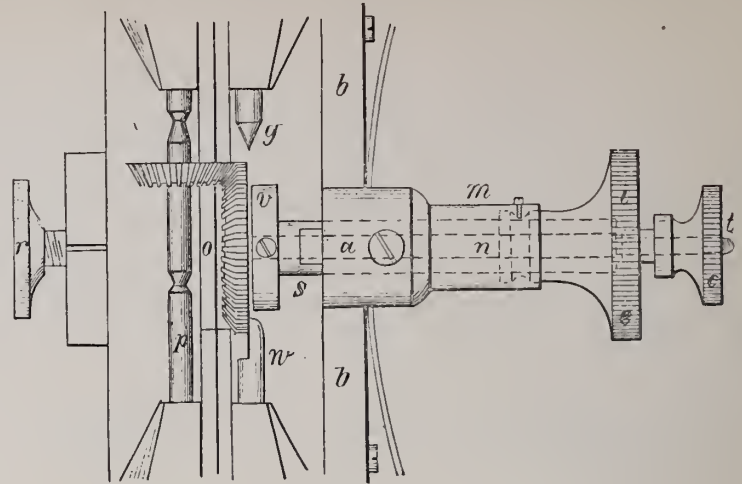

FIG. 1.

A second tube *s*, which carries the small circular smooth plate *o*, and ends in *i*, is shaped within *n* or *i* in such a manner that it will screw into nut *e* when introduced into the interior of tube *m*. By turning this nut, the small circular disc *o* can be made to go forward or backward. This tube *o s*, being perforated throughout its entire length, will receive staff *x* in *o* or *t*, which, by means of nut *C*, will fasten the crown wheel upon the circular plate *v*, as seen at *o*.

Use of the Tool.—To use the tool—that is, to determine the exact position of the two wheels, both horizontally and vertically, the position of the circular plate *v*, which is to carry the crown wheel, must first be established in its bearing to the center points *w* and *g*. This position will be effected by means of the nut *e*, and make it immovable by closing thumb screw *a*, which presses upon a face attached to tube *s*.

When the crown is fastened directly upon the barrel bridge, then the lower part of the crown, or the bottom of the sink in the bridge, upon which it is supported, is the face upon which the work is performed.

If, on the contrary, the crown is adjusted upon a steel or brass shoulder, fastened upon the barrel bridge, then the upper part of the crown is the plane, according to which the depthing measure must be taken, so that it receive a suitable height.

When the crown is adjusted directly upon the bridge, the point of the center must be removed from the face of the circular plate *v*, exactly by the thickness of the bottom of the crown wheel sink. To facilitate and be assured of the exactness of this starting point, center *w*, as is shown in the cut, has been filed exactly as far as the middle of its diameter.

Let us suppose, for example, that the thickness of the wheel be one-half millimeter, a piece of metal is filed of exactly the same thickness; center *w* is then advanced, after it has been made to turn one-half turn (so that the flat part be parallel with the circular plate), until it stands opposite to this circular plate. When this has been done, the position of *v* is regulated with the nut *e*, in such a manner that the empty space between the circular plate and the center is entirely the same with the thickness of the prepared piece of metal, and the tube *s* is fixed firmly by the screw *a*.

By the aid of the long screw *X* the crown is fitted upon the circular plate, in such a manner that this crown can move easily and without shake, and its good performance is secured by drawing on the small set screw which is seen below *o* (at *v*), and which passes upon the staff *X* at *Z*.

It only remains that the pinion is inserted in its place between the two centers to the left, and that the depthing is regulated by the

screw which opens or closes the two arms of the tool. When this depthing has been placed in correctly, the point of center *p* is laid upon the side of the watch movement, whereby it indicates the point at which the hole is to be drilled, which is to receive the staff of the winder, the point of the other center *w* will indicate the height of the bottom of the sink for the barrel bridge, where the crown will be adjusted.

This turning of the centers toward the side of the movement gives the vertical depth of the depthing, and the horizontal seizing still remains to be determined.

The pinion is removed from the tool, but be very careful not to loosen more than one center, in order to return the pinion exactly again at the same place. Staff *X* (*o t*), is then taken away, and the other shaft *y* is put in its place, whose round shoulder is traversed by a small sliding ring, which by an index *d*, terminates in a double angle; this ring is fastened at option with a screw.

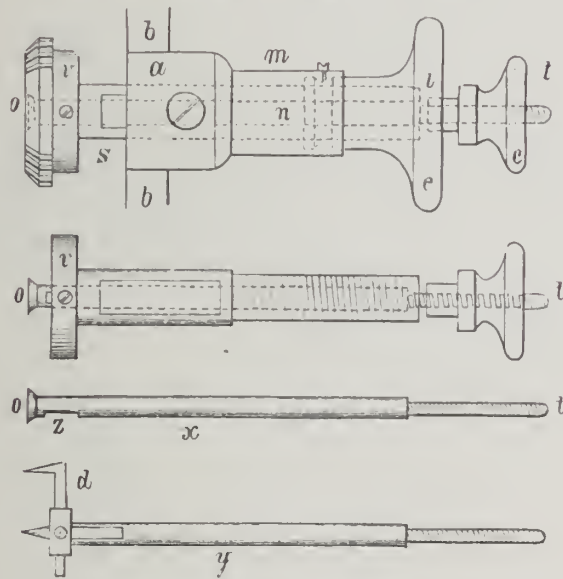

FIG. 2.

When the pinion has been returned to its place between the centers, the double angle of the slide is caused to brace against the basis of the conical pinion, and the slide is then fastened with a screw. When the piece *y* is drawn back, it will, by the removal of its central point to the end of the small tracing point *d*, give the distance of the center of the crown upon the plane, which stands vertical to the frame plate, upon which the basis of the conical pinion is situated.

All these operations demand infinitely less time than this description, and we may add that all depthing tools are appropriate for receiving this addition, whereby they are rendered capable to determine the angle depthings, and that this contrivance may, at option, be added or taken away.

Perpetual Calendar.

A SUBSCRIBER of the *Journal Suisse d'Horlogerie* inquired lately, through its columns, if there was any horological work containing a draught and plain explanations on the mechanical arrangement of a perpetual calendar. None of the readers responded to the question, wherefore the editor of said publication examined the large library of horological works and publications, in all languages and of all ages, at his command, without finding anything that was even approximately utile.

By this inquiry, therefore, a want had been discovered and required to be supplied; an inventive horologer agreed to furnish a satisfactory drawing and explanation, and the *Journal* published it lately as follows:

Wheel *H*, driven by the minute work, makes one revolution in 24 hours, and is provided with a movable finger *a*, which, bracing against a pin, is able to unlock the multiple lever *D* at its end *p*.

This lever, with motion center at *i*, operates by means of its several arms: 1, with end *C* upon the star-shaped week wheel *A* (with 7 teeth), and 2, with *b* upon the date wheel *C* (with 31 teeth). Finger *a* also permits the wheel *E* (with 59 teeth), which carries the lunar phases, to advance by one tooth per day.

That part of the train which forms the perpetual calendar, consists of a wheel *F*, with 31 teeth, which stands in depthing with the date wheel *C*. The first mentioned wheel, which, therefore, makes one revolution per month, permits at each revolution the wheel *G* (with 48 teeth) to advance one tooth, by means of the movable finger *n*. This wheel *G* will, therefore, complete its revolution in 4 years. The circumference of the counting wheel *B*, which is fastened upon the wheel *G*, accords with its circumference with the months of 31 days, and with the notches of least depth to those of 30 days; the 4 notches, which are deepest, accord with the month of February. A February notch will be noticed at *e*, which is of less depth than the other three; this is for the leap year of 29 days.

Now, the lever *D*, in a state of tension by means of the spring *h*, will drop back into its position of detent, after it has permitted both the week and the date wheel to advance, whereby its arm *r* will brace upon the counting wheel, and this, according to the position of the disc, either upon the circumference or into one of the notches.



The catch *u*, pressed by its spring, rests upon the snail *k*. At the second last day of each month it drops upon the deeper part of the snail. The lever arm *b* becomes active in its place on the next day because the catch has braced itself in the notch of the snail, and thereby permits that the arm *b* allows the wheel *C* to advance by as many teeth, so that the date hand stand upon the first day of the next following month. It will easily be seen that the catch *u* will have to drop by so much earlier into the notch, and will have to pass through a longer path, if the arm *r* rests in a deeper notch of the counting wheel *B*.

In the position occupied by the figure, the date hand indicates the 1st of December of the year preceding a leap year.

The two parts *m* and *t*, that the arrangement may be set first to the correct date, and by means of *t* to the correct lunar phase.

The finger *a* has been made movable, so that also the hands may be set backward, without anticipating any danger to the mechanism. When the wheel *H* moves backward, this finger is retained by arm *p*, and since it is beveled at its lower part, the pin located on the wheel may pass by below, by slightly raising the finger *a*, which is permitted by the flexibility of the part *s*, which contracts its shake.

REMARKS.—In the drawing the wheel *F* must have the same diameter as the date wheel *C*.

Clock Trains.

1. *The train and the calculation of the pinions and wheels, according to Jürgensen.* The train imparts to the regulator* the force of the motive power by means of wheels and pinions. The velocity of the wheels increases with their distance from the center of force, while the force decreases in proportion with this distance. The power of the last, or escape wheel, must be sufficient to replace the power which the regulator lost by motion, the resistance of air, and friction. The force of the main wheel must be proportional to the number of the revolutions of the last wheel, and be increased or decreased according to its larger or smaller velocity. If the force of the last wheel is supposed as = 1, and the number of its revolutions for one revolution of the first wheel = 4,800, then the motive force must be 4,800 times greater than that of the last wheel, according to the fundamental laws of mechanics, without taking into account the influence of the pinion friction.

The velocity increases by the union of two wheels of different diameters, when that of the larger diameter drives the pinion or wheel of the smaller diameter. This pinion, with regard to the wheel, makes as many more revolutions as the diameter of the pinion is smaller than that of the wheel. It will be seen, therefore, that it is easy to increase the velocity of the last wheel, if several wheels and pinions are united in such a manner that the first wheel drives a pinion, which concentrically carries a second wheel, which, again, drives a second pinion, carrying a third wheel, etc. This combination of wheels and pinions is called the train, and by its use the motive power is capable of acting a sufficiently long given time upon the regulator before it becomes necessary to renew it, or, as it is generally expressed, to wind the clock. The train, beside this, carries the hands, which mark the elapsing time.

Fig. 1 gives a combination of wheels and pinions. *A B C D* are wheels, and *p q r* pinions driven by them. The wheels gear in by means of teeth, which are situated around their circumferences. The number of these teeth must stand in the proportion of their diameters. The velocity of wheel *D* is proportioned to that of *A* as the product of the diameters (or of the radii) of the pinion; if the velocity of *D* is expressed by *V*, and that of *A* by *v*, we will have the following proportion:

$$a b \times p e \times q g : p d \times q f \times r h = V : v.$$

The number of the teeth of the wheels, which form the depthing, must stand in the proportion of their diameters.

EXAMPLE.—Let the diameter of a wheel be 30''' and that of the pinion 3''' , and the number of the wheel teeth 120; how many leaves must the pinion have?

ANSWER.—The diameter of the wheel 30''' : diameter of the pinion 3''' = 120 : *X*. $X = \frac{120 \times 3}{30} = 12.$

We therefore obtain 12 leaves.

Since the number of the teeth stands always in the proportion of the diameters, it follows that their size can be expressed by the number of the teeth, and, consequently, also that the revolutions of the wheels may be used in the calculation. When the number of teeth of a wheel and its diameter, and the number of the leaves of a pinion have been given, its diameter may be found by calculation; but in practice the size of the pinions or their diameters may easily be found according to practical rules, which we shall give further on.

We answer a few examples based upon the revolutions:

EXAMPLE.—To find the number of revolutions of the last wheel of a train of five wheels and 4 pinions, the first wheel having 100 teeth, the second 80, the third 60, and the fourth 50. (The fifth wheel not having a depthing, it is not taken into account). The first pinion has 20, the second 16, the third 10, and the fourth 8 leaves.

First Method.—We have seen that the product of the diameters of the wheels are proportioned to the product of the diameters of the pinions, as the velocity of the last wheel is to that of the first wheel,

*Mr. Jürgensen calls the pendulum or balance the *regulator* of the clock or watch. The term being very apt, we shall retain it in this series of articles.

which velocity we express with 1, and consequently is the velocity of the wheel:

$$V = \frac{\text{the product of the number of teeth of the wheels} \times 1}{\text{the product of the number of leaves of the pinions.}}$$

$$V = \frac{100 \times 80 \times 60 \times 50 \times 1}{20 \times 16 \times 10 \times 8.}$$

$$V = \frac{24,000,000 \times 1}{25,600} = 937\frac{1}{2}.$$

Second Method.—The velocity of the last wheel, or what is the same, the number of its revolutions during the time that the first wheel makes one revolution, is 937½. By dividing the number of teeth of each wheel by the number of the pinion leaves gearing into the wheel, then multiplying all their quotients with each other, and afterward with *v*, or the velocity of the first wheel, which we here express with 1, we arrive at the same results:

$$V = 100 \div 20 \times 80 \div 16 \times 60 \div 10 \times 50 \div 8 \times 1, \text{ that is}$$

$$V = 5 \times 5 \times 6 \times 6\frac{1}{4} \times 1 = 937\frac{1}{2}.$$

EXAMPLE.—To find the number of revolutions of the last wheel of a train, in which the pinions drive the wheels:

First Method.—Since the pinions drive the wheels, the velocity of the last wheel will be proportioned to that of the first pinion, as the product of the diameter of the wheels, and in inverse proportion of the diameter of the pinions, or, what is the same, as the product of the pinion leaves is proportioned to the product of the wheel teeth; if the velocity of the last wheel is expressed with *v*, and that of the first pinion with *V*, we will have

$$v = \frac{\text{to the product of the leaves}}{\text{the product of the wheel teeth}} \times V.$$

Let *A* (fig. 1) be of 60 teeth, *B* of 48, and *C* of 42 teeth. *D* does

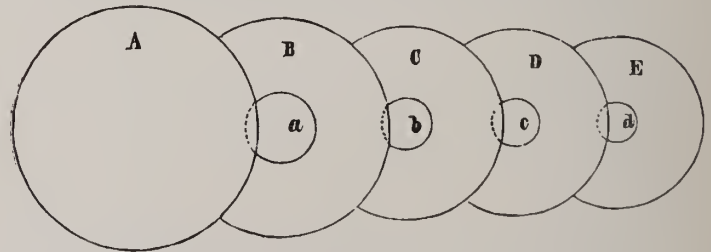

FIG. 1.

not come into account, since it has no depthing. If *p* is of 12 leaves, *q* of 8, and *r* of 7, and the number of revolutions of *r* in a given time be 2,700, then the number of revolutions of *A* in the same time will be

$$\frac{12 \times 8 \times 7}{60 \times 48 \times 42} \times 2,700 = 15.$$

According to this, the velocity of *r* is to that of *A* as 2,700:15, that is, the velocity of *r* is 180 times larger than that of *A*.

Second Method.—In order to avoid the multiplication of the teeth into each other and that of the pinion leaves, it is only necessary to divide the number of leaves of each pinion by the number of the teeth of the wheel driven by the pinion; multiply these quotients with each other, then multiply this product by the number expressing the revolutions of the first pinion, and the same result will be arrived at:

$$v = \frac{7}{4} \times \frac{8}{48} \times \frac{12}{60} \times 2,700,$$

$$\text{or, } v = \frac{1}{1} \times \frac{1}{6} \times \frac{1}{5} \times 2,700 = 180 \times 2,700 = 15.$$

The following two examples are useful for the calculation of the pinions for watches:

The number of teeth of the scape wheel is to be found, so that the balance make 16,800 vibrations per hour (or while the center wheel makes one revolution), when the number of teeth of the other wheels and the leaves of the pinions are given.

REMARKS.—The balance makes two vibrations for one tooth of the scape wheel, and if the wheel, for instance, had 20 teeth, then the balance would make 40 vibrations during one revolution of the wheel.

SOLUTION.—First calculate the revolutions of the scape wheel

during one revolution of the center wheel. Next divide the number of the found revolutions with the one-half of the number of vibrations, which will give the number of teeth which the scape wheel is to have. This can be seen by fig. 2. Let us suppose the number of leaves and teeth as follows:

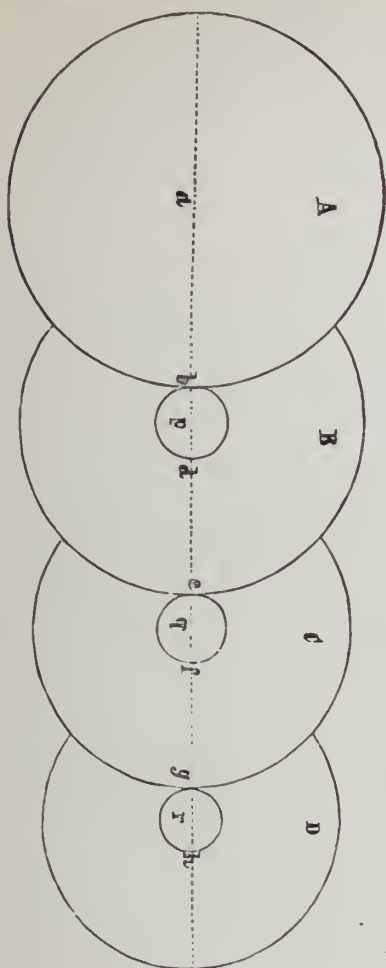

FIG. 2.

B, the center wheel, of . . .teeth, 80
C, the third wheel, of . . .teeth, 60
D, the fourth wheel, of . . .teeth, 56
a, the center pinion, for obvious reasons, is not taken into account.

b, the third pinion, of . . .leaves, 8
c, the fourth pinion, of . . .leaves, 8
d, scape pinion, ofleaves, 7

Then, according to the above, the number of revolutions of *E* = 600. The one-half of the vibrations is $\frac{168000}{2}$ or 8,400, which, divided by 600 = $\frac{8400}{600} = 14$ as the number required.

To find the hours of the motion of a clock and the number of barrel teeth or of the fusee, also that of the center pinion, so that the clock go for a certain length of time.

In fig. 2 *A* is the barrel, which gears into the center pinion *a*, which makes one revolution per hour. If we assume the number of barrel teeth at 96, and the pinion leaves at 8, and that the spring can make 3 revolutions before its activity be interrupted by the stopwork, the barrel will then make 1 revolution in 12 hours, because the number of its teeth, 96, divided by

the number of pinion leaves 8, makes $96:8=12$. These 12 hours, multiplied by the 3 revolutions, which the barrel can make, gives $12 \times 3=36$ hours for the clock's rate.

The number of teeth which the barrel is to have may be ascertained in the same manner, as well as the number of leaves, so that a clock go for a given time. It is first necessary to determine the number of revolutions of the barrel. If we suppose this at 3, and the rate of the clock at 30 hours, it will be seen that the barrel makes 1 revolution every 10 hours, and, consequently, must have 10 times as many teeth as the center pinion has leaves. Assuming the leaves of the pinion at 8, then the number of barrel teeth must be $10 \times 8=80$.

In order to make a clock go 8 days without winding it, an intermediate wheel and pinion are to be placed between the barrel and center pinion. If the barrel is assumed at 96 teeth, the first or intermediate pinion at 12 leaves, the intermediate wheel at 80 teeth, and the center pinion at 10 leaves, it will be seen that the intermediate wheel makes only one revolution in $\frac{96}{12} \times 8$ or 64 hours; so that with $3\frac{1}{2}$ turns of the barrel the clock will go over 8 days. The clock may, by the interpolation of wheels, be continued in such a manner that it will go a week, a month, or a year, without winding it.

REMARKS.—If the spring operates by means of a fusee, this, then, is the first wheel of the train. In this case the calculation is based upon the number of revolutions of the fusee instead of that of the toothed barrel.

We will explain next how the calculation of the depths is made, if the number of teeth and pinions is given; it still remains to become acquainted with the means used to find the suitable number of leaves for the pinions, so that they perform a given number of revolutions, and how this is effected.

In a train more or less pinions may be used, according to the larger or smaller size which is to be given to them; but we now suppose the number of pinions as given, and we commence to determine the number of leaves necessary for them; their product must then be multiplied by the number of revolutions required. Afterward gradually divide this entire product by the prime numbers in their order, until unit or one is obtained as quotient, in the following manner: First divide the product by 2, if it is possible, and continue to divide the quotients divisible with this number. After it can no longer be divided with 3, try the next following prime number 5, and continue until the quotient is one. Afterward make as many parts of these prime numbers as there are wheels contained in the train, and the product of these prime numbers from each part gives the number of teeth which each wheel must receive.

The following examples will render the process more comprehensible.

First Example.—To find the number of teeth of the wheels in a train of 3 wheels and 3 pinions, so that the last wheel make 200 revolutions while the first one makes one.

According to the above given rule it is necessary to first determine the number of leaves of the pinions; we assume the following:

The first pinion of 12 leaves, the second of 10, and the third of 8. By multiplying these numbers with each other, and next with the given revolutions, we will have $12 \times 10 \times 8 \times 200=192,000$; the divisors as the prime factors, divisible in this product, are found in the following manner:

Divisor.	Quotients.	Divisor.	Quotients.
192,000	$\div 2=96,000$	192,000	$\div 2=750$
	$\div 2=48,000$		$\div 2=375$
	$\div 2=24,000$		$\div 3=125$
	$\div 2=12,000$		$\div 5=25$
	$\div 2=6,000$		$\div 5=5$
	$\div 2=3,000$		$\div 5=1$
	$\div 2=1,500$		

These prime factors are arranged in appropriate portions, say in about the following manner:

$$5 \times 5 \times 3 \times 2 = 150;$$

$$5 \times 2 \times 2 \times 2 = 40;$$

$$2 \times 2 \times 2 \times 2 \times 2 = 32.$$

These results, 150, 40, 32, can be used for wheels, the last one of which is to make 200 revolutions, as can easily be demonstrated, because

$$150 \div 12 = 12\frac{1}{2}$$

$$40 \div 10 = 4$$

$$32 \div 8 = 4$$

since $12\frac{1}{2} \times 4 \times 4 = 200$.

REMARK.—Should these numbers not be suitable for wheels, and the teeth, according to the dimension of the wheel, would become either too narrow or too broad, the prime factors may be arranged in another manner, say, as follows:

$$5 \times 2 \times 2 \times 2 \times 2 = 80$$

$$5 \times 3 \times 2 \times 2 = 60$$

$$5 \times 2 \times 2 \times 2 = 40$$

These results, 80, 60, 40, will also be suitable for the given number of revolutions, which can be demonstrated as follows:

$$80 \div 12 = 6\frac{2}{3}$$

$$60 \div 10 = 6$$

$$40 \div 8 = 5$$

since $6\frac{2}{3} \times 6 \times 5 = 200$.

(To be continued.)

How to Make and Engrave Silver Bangles.

BY EXPERT.

IF THE bangle is to have a ring for attaching it to the bracelet, as shown at *a*, fig. 1, it is best to have this hard soldered on before polishing; and in such cases a recess for the ring should be

turned out in the coin holder, as shown at *a*, fig. 2, and *A* the recess for the coin; in all other respects the brass plate *B* is precisely as described in former article.

In fig. 1 is given some additional borders, and, for the sake of lucidity, they are repeated straight. The border shown at *b* can be cut either plain with a flat-bottomed graver, or wriggled; the line at *g* is wriggled, and will serve to convey the idea; it is done by holding the graver nearer perpendicular than in ordinary cutting, and rolling it back and forth as it is pushed ahead; the manner is shown in fig. 3, where *h* is the graver and *i* the job to be engraved. The border at *d* is alternate wide and narrow lines; the heavy bars can also be wriggled. The border at *e* consists of an inner margin line, as shown at *e*, fig. 1, and heavy radial cuts made with a round-bottom graver, shown at *j*. At *k* is shown another border; this is done entirely with the ordinary graver. The same remarks as I made in my last article on borders apply in these as regards spacing—the regularity of the patterns being their chief beauty. After the border

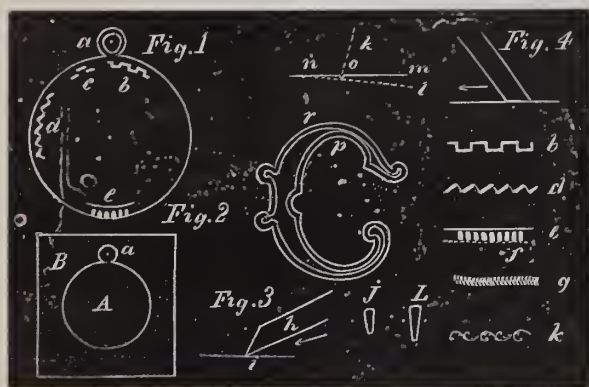

is engraved, the monogram can be designed directly on the face of the dime, by means of a lead pencil—a No. 3 Faber being about the right hardness. To do this, gamboge is stippled on the face of the dime by the end of the finger. Gamboge can be obtained at any drug store, but it must be in the stick or solid form. This gum readily dissolves in water, and to use it in this case, wet the end of the second finger with water or saliva and rub it on the stick of gamboge, when it will make a beautiful light yellow fluid; if this is rubbed on the dime, and dabbed or patted with the end of the finger as it dries, the gamboge will form an even orange colored coating which will take the pencil without in any way marking the polish. Two things are to be desired in laying on such a coat of gamboge—first, to lay the coat as smooth as possible, and next to harden it so the point of the pencil will not cut through. The first can be got by practice, and depends a good deal on the thickness of the coat, but, as remarked above, practice is the best instructor, only keeping in mind the fact that the smoother the surface of the gamboge, the nicer you can design on it. To harden the gamboge so a pencil as hard as a No. 3 will not cut through, heat up the bangle to about 45° F.; this can be told by the shellac cement which holds the dime in place smoking a little. One advantage of the gamboge coating is that any correction can be made by simply wetting the finger and dabbing over; but such wetting softens the gamboge so that your pencil will cut through if you are not very careful. Now comes a point on which the writer insists, and that is to design correctly and quickly. If you have any spare time, *amuse yourself* by designing monograms or crests. A pen is about the best instrument to practice with—it makes clean, sharp lines, and, more to the point, it learns one to draw decisively; its lines are in one respect very like graver lines, not easy to change. For specimens of monograms, books are not exactly what one needs. To explain what I mean by this is, books on such subject are the work of one man, and, about 99 chances out of 100, no matter how skillful he may be, he has some certain form or type of letter which he has for his *pet*, his hobby; so do not pin your faith on any one style. If you see a nice monogram copy it, and if there is anything particularly desirable, engrave it. To copy a monogram or other engraving, get some good printer'

ink, not a quick drying ink, but of good body and color, and rub over the engraved surface so as to fill every line; wipe most of the ink off with a cloth or tissue paper—the mistake you will probably make is in trying to clean the work too much, but, as I so often recommend, take lessons of the schoolmistress *Practice*; she is a little slow, but eminently thorough, and tolerates no laziness. When the lines are all full of printer's ink, mix up some plaster of paris with water until it is like thick cream, and pour on the job, covering all the work you wish to copy. Let the plaster stay on until nearly dry; just to wait for it to set will not get a good impression. By rigidly adhering to the above advice, you will soon get a range of styles in letters which will give you great power, both in forms of letters and tool work.

As was suggested early in these papers, rapidity, with good effect, is what you want in silver bangles—discarding everything that requires careful and laborious work, such as coloring. I mean by this fine parallel lines across the face of the letter. All this is elegant for such monograms as you get paid for, as, for example, monograms on watch cases; but with bangles you must get bright, cheap effects. There are many ways to get at such effects, but the difficulty in describing such lies in the fact that a letter which would be quickly made by one man would become labored in the hands of another; and does not so much depend on the form of letter as it does on the way you go about cutting them. A flat-bottom graver, shaped as shown at *L*, is the tool used to give the bright beveled surface to many letters; as, for instance, at the large *C*. The letter is first outlined as shown; and then, by turning the graver to one side at about the angle shown at *k*, the metal is cut away between the two outer lines. To make the idea plain we will suppose the line *m*, over the big *C*, represents the surface of the metal to be cut or engraved, and the notches *n o* represent the two graver lines surrounding the letter; the line *k* shows the angle at which the graver is to be held; and the dotted line *l* the angle to be presented by the cut surface. There is some skill necessary in cutting the margin lines to get them parallel; but the greatest skill is required in cutting the bevel surface so as to make a smooth clean cut, presenting a bright reflecting surface that is free from wriggles and waves. Learn to make such cuts both in hollow and round, as, for example, at *p* and *r*. The reader is warned that the use of this tool in the manner and for the purpose mentioned, is one of the most difficult in the art, and still is indispensable in bright cutting. Of course, it is understood that all the gravers are polished after sharpening, and the sharpening done on an Arkansas stone. A Washita stone can be used to rough down, but the final angle and finish previous to polishing requires a fine Arkansas, free from those hard streaks and veins we so frequently see in these stones. A piece of boxwood, such as wood engravers use, is a nice thing to polish gravers on. The polishing material can be either diamantine and alcohol; if an exquisite polish is desired, steel rouge and oil, or a mixture of putty powder (oxide of tin) and tallow. The sole of an old shoe makes an excellent polishing strop—not so elegant, perhaps, but good—cut to say 2 × 3 inches, and glue on a block. After the graver has been whet it should be *jabbed* into the end of a block of wood to remove the burr. A piece of maple scantling, 3 or 4 inches square, and sawn off so as to be about 1½ inches thick, and of course presenting the end of the wood, is the best; but birch, hickory or ash will do, if used in the same way. In polishing the graver, the polish is effected by drawing the graver toward you over the wood or leather on which the polishing material is spread, but care must be used to present the graver to be polished to the wood block or strop as near flat as possible, so as not to polish off the angle, and get your graver like a sled runner. When you polish the end or front of your graver, hold it as shown in fig. 4, drawing it in the direction of the arrow.

[From Our Special Correspondent.]

The National Exposition at Zurich.

ZURICH, Aug. 16, 1883.

The list of awards has finally been announced, and every one is satisfied that the jury have been very discriminating and impartial. It consists of Messrs. Brandt Frères, Bienne; Jurgensen, Jules F.

U., Locle; Patek, Philippe & Cie., Geneva; Pignet Frères, Orient de l'Orbe; P. Besançon, Chaux-de-Fonds. Of course, all the houses that have representatives at New York were duly honored. We cull from the list, which we curtail for sake of brevity, the following awards:

FINE WATCHES.

Association Ouvrière, Locle; Courvoisier, Fritz Buttes; Faurefils, Ed., Locle; Girard, Perregaux & Cie., Chaux-de-Fonds; Golay, D., Sentier; Jaccard & fils, Henri, Ste-Croix (Vaud); Jurgensen, J., Alfred, Locle; Keller, D., Aarau; Labet, L. F., Neuchatel; Maçret, Sylvain, Montmèraël (Neuchatel); Schöchlin, Wil., Bienne; Tissot & Fils, Ch.-F., Locle.

ORDINARY WATCHES.

Aeby & Landry, Madretsch (Berne); Apothelot, E., Colombier (Neuchatel); Bachschmid, F., Bienne; Bergeon Frères, Locle; Bertholet, Alb., Bienne; Berthoud, Ed., Cortaillod (Neuchatel); Beuret, Em., Renan (Berne); Blösch, Edouard, Bienne; Bornand, Aug., Ste-Croix (Vaud); Bornand-Berthe, E., Ste-Croix, (Vaud); Bornan & Cie., Eug., Ste-Croix (Vaud); Brcting & Cie., Aug., Locle; Buttiker-Bourquin, W., Chaux-de-Fonds; Cattin-Hug, J., Soleure; Choppard, James, Bienne; Choppard-Kummer, Bienne; Choppard, L.-U., Souvillier (Berne); Couleru-Meuri, C., Chaux-de-Fonds; Courvoisier & Cie., Chaud-de-Fond; Cuanillon, Fréd., Chaux-de-Fonds; Droz-Jeannot fils, Brenets (Neuchatel); Droz & fils, Alcide, St. Imier (Berne); Dubail, Monnin, Frossard & Cie., Porrentray; Eberhard & Hilberer, Bienne; Favre Frères, Neuveville et Cormonet; Franchillon & Cie., Ernest, St.-Imier, (Berne); Frèchelin, Louis, Colombier (Neuchatel); Geiser, L.-A., Travannes (Berne); Gimel & Ottone Frères, Locle; Gränicher, N., Bienne; Gugenheim Neven, M., Bienne; Humbert & Sauser, Soleure; International Watch Co., of J. Rauschenbach, Schaffhouse; Jaccard du Gros, S., Ste-Croix (Vaud) et Genève; Jaccard & Co., J.-A., Lausanne; Jacot-Burmann, Bienne; Jeanneret & fils, St.-Imier; Kuhn & Flèche, Reconvillier (Berne); Lausel-Campiche, A., Zurich; Leuba-Fatton, Buttes (Neuchatel); Von Loehr, A., Bienne and other places; Mermod Frères, Ste-Croix (Vaud); Montandon Frères, Locle; Montandon, U., Ste-Croix (Vaud); Müllertz & Robert, J., Chaux-de-Fonds; Oster, Phil., Bienne; Perret & fils, Brenets (Neuchatel); Roth & Cie., J., Soleure; Rozat, Louis, Chaux-de-Fonds; Sandoz Frères Ponts-Martel; Schild, U., Granges (Soleure); Schmidt, Charles-Leon, Chaux-de-fonds; Société d'horlogerie de Granges (Soleure); Société industrielle à Montier-Grandval et Succursales; Thalmann, Henri, Bienne; Thommen, G., Waldenburg (Basle); Weber, Aug., Bienne; Wille Frères, Chaux-de-Fonds; Wyss & Cie., J., Bienne.

DETACHED PIECES.

Bæhni Frères, Bienne; Huguenin, Ch.-L., Locle; Von Kænel, Th., Bienne; Kaufmann, Jean, Fleurier (Neuchatel); Lecoultré & fils, U., Seatier (Vaud); Lorq-Maumary, Chaux-de-Fonds; Mathey fils, Auguste, Jaluse-La-Roche, Locle; Matile, P., succ. de Perrelet & Martin, Nyon (Vaud); Muller & Schweizer, Soleure; Perrudet, H., Neuchatel; Pignet, Alfred, au Brassus (Vaud); Rochat, L.-J., Brassus.

I omit the list of other branches of horology, such as electric clocks, watch material, cases, crude blanks, etc.

It is perhaps not without interest, while on the subject of the Swiss watch industry, to devote a few lines to past Expositions.

Switzerland participated in the first World's Fair, of London, in 1851, and was represented in the horological group by 50 exhibitors, when, of 4 of the large medals (council medals), it carried off one, which Mr. J. C. Lutz received for the best balance springs. The Swiss watch industry also received 9 prize medals out of 30, and 7 honorable mentions out of 17. One prize medal was also carried off by a Swiss exhibitor for steel best adapted for watches.

Switzerland had about 60 exhibitors at Paris, in 1855, to whom were distributed 50 awards (10 medals of the first class, 21 of the second class, and 19 honorable mentions). Mr. Lutz's balance springs also earned for him a medal of honor, and the Swiss Federal

Department of Commerce received a collective medal of honor for the Swiss collection of horology.

In 1862, at the second World's Fair, of London, Swiss watch industry was represented by 67 exhibitors, when there were divided among them 57 awards (24 medals and 33 honorable mentions).

At the Paris exhibition of 1867, Swiss watch industry counted 152 exhibitors, or, more correctly speaking, only 86, because 68 belonged to the Jura. Of the former number (86), 44 obtained awards, to wit, 4 gold medals (out of 12), 6 silver medals, 15 bronze medals, 19 honorable mentions, and 2 medals of co-operators.

In 1873, at Vienna, 76 exhibitors received 57 awards (5 diplomas of honor, 10 medals of progress, 28 medals of merit, 16 diplomas of encouragement), and 7 medals of co-operators.

The Centennial Exposition of Philadelphia, in 1876, was the first American exposition in which Switzerland participated; 54 exhibitors obtained 41 medals.

At Paris, in 1878, there were 136 exhibitors, who obtained 118 recompenses (1 diploma of honor for the entire collection, 9 gold medals, 34 silver ones, 41 bronze ones, 33 honorable mentions), and 13 awards of co-operations (1 silver and 11 bronze medals, 1 honorable mention).

This, Mr. Editor, is a hasty eye-glance thrown over the list of International Expositions; not to say anything of that held at Sydney, in 1879, in which Switzerland was almost not at all represented, nor of that at Melbourne, in 1880, of dark memory, although the entire Swiss collection obtained the first prize.

After having compiled the above paragraphs for the envy of your American manufacturers, let us change the subject and revisit the hall, after having seen "a man around the corner."

In the immediate neighborhood of the *vitrine* of the Bureau of Coinage, we see a number of show cases, all of which contain single pieces of watch work, but nevertheless they are of great interest to the watchmaker at large. Those of Emile Huot, of Les Bois, Jura, are the first. His case is crowded with all sorts of parts for cylinder and anchor escapements, which are shown in such a manner that the progressive step from the blank to the finished article can be traced through all its gradations. For instance, alongside of the cylinder and its scape wheel, we find the crude round steel and the steel sheet, from which these parts are manufactured. The steel wire has been drawn to the exact size of the cylinder, and the sheet rolled to the necessary thickness for the height of the scape wheel. Next follows the crude drilled cylinder shell, unhardened, without the notches, etc., until, finally, the crude work has been elaborated into the finished cylinder. The same with the escape wheel, so that the attentive watchmaker, who observes these steps carefully, is able to make a scape wheel himself.

In this branch we also find M. Ch. L. Huguenin, of Locle. This firm exhibits simply parts of anchor watches, but candidly said, their excellence of execution leaves no room for further desires.

In the same branch is Henri Perrudet, of Neuchatel, who principally manufactures parts of very fine English lever movements, of several distinct sizes, and observes the same rules as those of your excellent American watches—that one part fits exactly in the place of its predecessor.

Hard by is Mr. Neuenschwander, of Biel, whose show cases glitter with polished case springs, of an excellent quality and finish. Every watchmaker knows what an important part these springs perform in the *tout ensemble* of the watch, and where is the repairer who has not felt a strong inclination of pitching a watch case with bad springs, no matter whether of gold or silver, to—to—well, say against the wall. He informs us that it is a very difficult piece of work to make a good spring; the train and escapement makers are lauded for the excellence of their work, the casemaker for the beauty of the case, while the poor spring maker is hardly ever thought of. As he said, it is very difficult to make a good spring, especially when it is calculated to give body and resistibility to the case rim. The weaker the case rim, the more difficult it is to make and fit in a snap

or fly spring, if it is to discharge its function with exactness. This part, which is so very easily subject to breakage, must be tempered with the greatest nicety, one iota too much or too little renders it unfit for service, and only by the exertion of the greatest care can its great liability to snapping be prevented. The uniting of the springs with the case rim must be thus that in case of breaking, the fractured pieces can easily be taken down, without anticipating an injury to the case.

We pass by several show cases and come to that of M. Bourquin-Borel, of Biel, manufacturer of watch hands, who, indeed, exhibits all the heart can desire in this line of goods. We see the stamps—*patrices* and *matrixes*—with which the hands are stamped, also the steel sheet used for the purpose. After having been cut out, of course the hand is not yet ready for market, it must be shaped by the file. The common article is sent off in the crude condition, but the finer qualities demand a good deal of retouching.

Next we come to a veritable piece of claptrap to catch the eye of the unsophisticated. The second half of the nineteenth century has developed human astuteness in a wonderful manner. In an attractive show case, surrounded by large posters and small hand bills, we find advertised the only true, original, unailing (my adjectives are exhausted) traveler's clock, with alarm to waken the dead, and luminous dial. It is said that the earth, some time ago, found out by one of these timepieces that it was making extra time in its orbit, wherefore it slackened up its headlong course, to get into beat. The clocks are done up in a nickel case, "shoots the same like silver;" the poster rates them at 6 francs wholesale, 8 francs retail; to be sold during the exposition at wholesale prices. He who buys one gets a nice patent-spring cradle as a gift, while the purchaser of two is made happy with a rosewood coffin, free gratis, and for nothing.

Your correspondent, being frequently told that he sleeps all his little remaining senses away, does not invest in these alarm clocks (he being only alarmed when he wakes up at an unreasonable hour before 10 P. M.), but passes on and inspects the beautiful engraver's works of Messrs. Riesen & Son, Ulyssee Richard and Fritz Hubacher of Biel. The classical engravings of all three firms are verily executed by the hands of masters.

It would be wrong to pass by the side of two old Biel firms—Mr. P. P. Beck, whose age has not impaired his skill of manipulating the graver, and Mr. Chopard de Bel.

I will bring my letter to a close, for fear of tiring your readers, reserving for a third communication several matters of interest—the electric clocks by M. Hipp, watchmakers' utensils, etc., and I have meanwhile the honor of signing myself, Yours, etc.,

JAN.

Repairing Watch Cases.

[By W. SCHWANATUS, Berlin, Prussia, in *Deutsche Uhrm. Zeitung*.]

Continued from page 279.

AFTER RIM and joints have been reduced to order (because success depends on these), a fairly satisfactory result will generally have been obtained; if, however, the bottom does not close sufficiently tight, seek to make the rim narrower with a riveting hammer; the same result may also be obtained by using the planishing stake. The latter stake is for this purpose fastened in the vise, the rim is placed into it, and it is tightened with careful taps upon the closing edge of the rim. If, after this, the bottom does still not close sufficiently firmly, the closing at the central part may also be remedied by filing with the cross file. Care must be taken that the closings are made a little conical, and it is well to take a well-proportioned case as pattern; you will be successful with a little attention. If the bottom closes now, but still not sufficiently regular, take the case in the left hand between the thumb and forefinger, and with the riveting hammer give it slight equal taps upon the outermost snap edge of the rim, whereby the defect will have been cor-

rected. Do not strike sufficiently forcible, however, to produce hammer marks; should any be produced by accident remove them with a gentle file or grinding. When the case has finally been restored to closing, clean the parts, and put them together. With new cases, especially silver ones, it frequently occurs that they close very tightly, and obstinately resist opening, so that the watchmaker is forced to ease the snap by means of a graver. Although he will frequently obtain his purpose hereby, it occurs fully as often that through ignorance he utterly ruins the case by cutting away the outer edge. The latter process is entirely useless, because the bottom cannot be closed if the outer snap edge is wanting. If he desires to employ the graver to ease the closing, let him slightly cut around the entire circumference, at least whereby he will preserve the same closing face.

The following method for easing the snap is far more speedily, and insures success: With careful taps with a riveting hammer upon the extreme outer snap edge of the rim seek to widen it a little. Should a few hammer marks have become visible remove them with a dull file, and next pass over the rim with a burnisher.

It occurs quite frequently that the dust cap presses upon the cap, so that it cannot be closed. The casemaker has two means at his command to speedily correct these defects. Should the pressure be only trifling, widen the hole in the dust cap from within with an emery chamferer; this is very quickly done, and the hole retains a neat appearance. Many watchmakers often try to correct such faults by the use of a graver, by scratching the hole from within; this remedy, however, is objectionable, since the square hole is deteriorated in appearance thereby. If the pressure upon the dust cap is of any magnitude, it is to be taken out; it is also advisable to take out the bottom. Silver cases have only one pin in the joints, which, however, must be taken out in the same manner as by gold cases.

A punch may be employed for taking out the pin of the dust cap. When the latter has been taken off, lay its outer face upon a piece of felt, and a small piece of silk paper or polishing leather upon the inner, so as not to injure the gilding; next take a half-round case stake, and with an iron hammer strike a careful tap upon the place which is to be raised, whereby the defect will have been corrected.

Such raising may also be produced in the same manner, at places where the dust cap presses upon the escapement; the tap must be made in such a manner, however, that it show no bulge upon the outside of the dust cap; also consider the space disposable between bottom and dust cap.

There is generally sufficient room in silver cases that a small bulge causes no inconvenience; if, however, you find that the bottom presses upon the dust cap, so that no raising can be made, it is better to give the case to a casemaker. The pressing of the bottom upon the dust cap is one of the most disagreeable defects, and the greatest hindrance for producing a good closing. Although I can offer no advice to the watchmaker, I will at least make him acquainted with the manner in which the casemaker works to make a bottom higher, which is not by any means an easy task, especially with new watches, which must in no manner show that the bottom has been raised. The engine turning is so sensitive that the least mishap is shown at once, and it is then very difficult to obliterate it.

To make a bottom higher, it is laid upon a piece of heavy leather, and then rubbed uniformly with a steel from within. If the bottom is thick, it is a very tedious piece of work, and it must several times be glow-heated, especially with gold cases. If the bottom is well worn, however, less depends upon a neat execution; a stake is fastened in the vise, the bottom is laid upon it and well rubbed over with a good burnishing steel. Seek to first raise the rim in this manner, which will greatly expedite the work. I repeat my above remark, however, that only old and worn cases can be treated in this manner, and when nothing depends upon a neat looking job.

When the bottom has been successfully raised by the specified process, it is to be repolished, because the polish has been injured

both inside and outside by rubbing with the steel. All the bulges in the case must be taken out before it is repolished, if it was not done already at the time of raising the bottom by rubbing. For this purpose fasten a flat stake, which is to be free of blemish, ground and highly polished, in the vise, and then take a good wooden hammer—this must also be polished, and consist of hard wood—and carefully beat out the dents one by one; they may also be pressed out with a burnisher from within, by laying the bottom upon a heavy piece of leather as aforesaid, and carefully pressing out each dent. Should there be any in the bottom rim, place a stake from within against the rim, and remove them by using a riveting hammer.

I shall devote a separate chapter to the smoothing and burnishing of cases.

The endeavor to raise the bottom having been successful, and the defect removed, cleanse the central part and the bezel, burnish the bottom within as well as without, and put the case together.

It is generally very easy, with cases with spring snap, to reduce them to closing, and I shall specify a few manipulations necessary for the purpose.

It occurs sometimes with new cases that the bottom will not remain shut, because its snap cannot seize sufficiently far under the spring. To remedy this fault, take out the snap spring and underfile its head with a very gentle file; next take a fine emery file, and assist the spring head from underneath, where you have filed. This emery file is the best tool to be used, because it is easiest to with it remove the burr which has been formed by filing.

Another remedy, equally expeditious and easily applied, can be made use of in the following case: It is often found that the bottom, especially of old and worn cases, will not close, although the snap of the rim may still be in good order, so that it would not be necessary to solder in a piece to produce a good closing, as is often to be done. When you meet such a case, take out the spring and file at the central part at the place where the spring head rests in it, the outer closing edge, with a small square file, forward out, so that the spring head can stand out a little more. When filing out in this manner care must be taken not to make the space too wide at the sides, and that of the closing edge a little thread still remains standing. Then take the spring and examine it, whether it possesses the necessary spring hardness; if too hard, draw its temper a trifle, and next place its neck—the part between spring head and screw hole—upon a small piece of wood, and strike the spring carefully with the riveting hammer, so that the spring head inclines more forward. It is self-apparent that the spring must hereby not lie hollow. When it has been straightened in this manner, place it into the central part, and ascertain whether the error has been corrected; if the remedy has not been sufficient, the treatment of stretching the spring may be repeated. It is very advisable also, in this instance, to round the outer edge of the snap spring with the emery file, whereby a good and large snap is produced. If, however, the spring has, by a long continued use, worn away the closing face at the rim, so that you are forced to solder a piece in the bottom rim to produce a closing, the moving forward and straightening the spring is of little account, and I can only advise to turn the job over to a casemaker.

It is frequently found, chiefly with new cases, that the bottom will not fly open sufficiently far, which error is sought to be corrected by many watchmakers by applying a little oil between the joints and the head of the lifting spring, and seek to render the joint pin more supple by moving the bottom to and fro. This method for remedying the defect is not advisable, however, and it will often be found that the very reverse is produced thereby. The surest and speediest manner for overcoming this defect consists in taking out the end pins, and with a punch very slightly drive the middle forward; in the majority of cases only a very trifling starting is necessary. The operator has it entirely in his power, by shifting the pin, to make the bottom more tight or easy. When set into order, reinsert the end pins, and if they should have become useless, owing to the change of the center pin, file others. It may also happen that the middle pin

is entirely to be taken out and slightly weakened; when this becomes necessary, it is also to be shortened at the same time.

I finally mention another error, easily corrected, and one which is often found in new cases, to wit, that the closing spring is pressed back when the stem is turned, whereby the case flies open. If the closing is otherwise in good order, the fault will be due to that the push button is not sufficiently filed out. Take it out and correct it by filing either with a small round or flat file.

TAKING OUT THE DENTS.

New watches, which have for some time been in store, will often be found slightly indented; these dents can easily be removed in the following manner: If they are of such a nature that it is not necessary to take the case into pieces, it is best to leave it together; if they are not to be reached with the hammer, the case is to be taken apart—this depends entirely upon the nature and situation of the dents. There are various stakes for taking out the dents from the central parts, according to the size and internal shape of the latter. A suitable stake is found, fastened in the vise, and by applying the dented part to the stake, seek to raise the dent with the riveting hammer. Generally speaking, this is no difficult work, and you will be successful in the majority of cases. When the dents are removed in this manner, take a very gentle file and file over the places carefully—that is, if the central part is smooth; in a contrary case, of course, you cannot touch it with the file—or the central part, in case it be smooth, as it generally is, the places may be ground with a stone and afterward polished.

TAKING OUT THE DENTS FROM RIMS.

For this work the casemaker has half round stakes with thin edges, which are set into the rims, after which the dents are taken out with the hammer. Afterward the places are either filed over or ground, and polished again, as previously explained; the removing of dents from the rims and central parts, in case said dents should not be too deep, so that the snaps are drawn into sympathy, requires no great trouble; the next work is of more consequence.

REMOVING THE DENTS FROM THE BOTTOM.

Several appropriate stakes are necessary for this. At first two stakes are necessary, a round one to straighten the edges, and a half-round one to correct the faces with it. If the bottom is thick or if the dents are rather deep, the repairer can at first try to take out the dents by means of a flat so-called cylinder stake and a wooden hammer, by raising them with short and steady blows. If the dents are taken-out in this manner, and only a shadow remains visible upon the bottom, they are laid upon a piece of leather, and the places are additionally worked over from within at these places with a burnishing steel. With old and worn buttons the burnishing steel may also be used from the outside by fastening the case stake in the vise, holding the bottom firmly upon it, and smoothing it from outside with the steel. I would call special attention to the fact that the burnishing steel can be used only for the outside of old cases, because the engine turning is very sensitive. Be also careful not to round the bottoms of either cylinder or anchor watch cases. If it should occur, nevertheless, that the bottom will rise up in the middle, take, in order to remove this very disagreeable accident, the half-round burnishing steel, and with it press the bottom in its entire rounding from within to the outermost edge, and the bottom will become flat again. Weak bottoms, however, if they are to be restored again to flatness, must be placed between two glowing plates, since they can be reduced successfully only in this manner. This, however, is no work for the watchmaker, since the tools and utensils necessary are out of his line. The same process is observed for taking out the dents from dust caps.

(To be Continued.)

The Recoil Pin Escapement.

THE NUMBER of the known recoil escapements for watches is very small; we have, in fact, simply the verge, which is classed to this in the manuals of horology.

In the following we give the description of an escapement with recoil little known and seldom seen. The recoil motion of the balance is very small, and its vibrations are freer than those of the verge escapement.

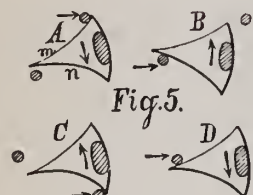
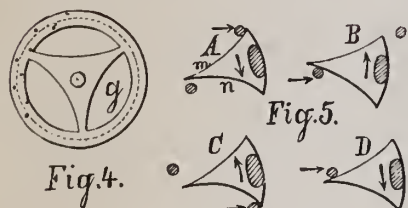
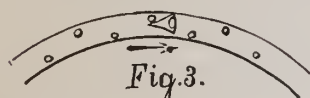
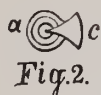
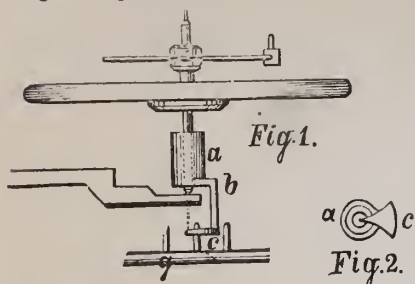

The scribe wheel *g* is provided with 30 brass pins, which stand vertical to the face of the wheel; one each of them operates upon the wedge-form part *c* of the piece of steel *a b c* fastened upon the balance staff; *a* is a tube, provided below with a shoulder, which ends in the support, *b*, with its wedge-form part *c*. The wedge-form part *c* has two moderately curved lifting planes, at which the wheel pins slide along, and thereby cause a revolution of the balance. Where the two lifting planes join in a point, repose takes place (as is shown in fig. 5 at *B* and *D*); but since the point of *c* exactly falls together with the balance axis (supposed to be prolonged), it will be easily seen that the recoil of the wheel can only be a trifling one, except it be that the vibrations be almost one vibration in extent, so that the pins are crowded along at the lifting faces.

Fig. 1 gives a side view of the escapement; scribe wheel is indicated only by a small portion; it can be seen better in figs. 3 and 4. Upon the dotted circle, fig. 4, in the middle, between the two pin rows, is always found the point of wedge *c*, and consequently also, supposed to be prolonged, the center of the balance axis. Each pin lifts the balance 40°; the drop, when leaving the lifting plane, is very small. The kind of friction at the lifting is an escaping, and at the recoil an entering one.

Fig. 5 sketches the performance of the escapement. If we designate the exterior lifting plane *m*, and the interior one *n*, because the latter, during the standing still of the escapement, points to the wheel arbor, it will be found that the curve of the inner lifting plane is curved a little more than the other one. At *A* a pin is on the point of leaving the outer lifting plane, the next pin then falls at once upon the inner lifting plane upon repose (see *B*); but the lifting indicated at *B*, by arrows, does not take place at once, but the balance makes the revolution given at *A*, consequently the pin, making repose at *B* upon the inner lifting plane, is forced to make a small recoil, until the balance, by reason of the operation of the balance spring at tension, moves to the opposite side, and the lifting indicated at *B* occurs. *C* represents the end point of the just mentioned lifting, after which the next pin again falls upon the outer lifting plane (see *D*), suffers recoil and then performs the lifting, as was already indicated at *A*. The play of the escapement is constantly repeated in this manner.

The balance needs no banking pin in this escapement; the pivots of the balance staff must be a little thicker than that of the wheel. The watch submitted to my inspection was provided with a fusee, and disposed in good proportions; the balance had a diameter of 23 m., the wheel with 30 pins had an outer disc diameter of 14.2 m. It can easily be seen that this pin escapement does not attain to the excellencies of the cylinder, but undoubtedly it is better than a verge, by its smaller wear of the operating parts, and greater freedom of vibrations.

F. ROSENKRANZ.

Advice to Watchmakers' Apprentices.

BY A MAN WHO HAS SPENT TWENTY YEARS AT THE BENCH

I SHALL take the risk of describing another furnace, even though it may seem to be prolix on the subject of melting furnaces. Although perhaps it would be better to say describe another method of blast, or air supply. There is no change in the furnace from those shown, but the bellows is different: as, in the present case, three small pair of hand bellows, which can be obtained cheaply of any large hardware store or house-furnishing establishment. These bellows are arranged in such a manner that a constant blast is obtained. To do this, three pair of ordinary hand bellows are arranged so as to be worked in succession by three cranks set at an angle of 120° to each other. The arbors carrying these cranks have mounted on each a cast iron spur gear wheel, 2 inches in diameter. These wheels can be obtained of any large hardware house; at any rate, they can be got of Goodnow & Wightman, Cornhill, Boston, Mass., for a few cents each. Fig. 1 shows the position of the parts; *F* is the furnace, as described in former article; *a a a* the wheels mentioned above. At fig 2 is a plan of the wheels and arbors as if seen from above; a piece of wood running diagonally under the brick work of the furnace is shown at *A*; this serves as a support for the end of the arbors *b b b*, carrying the cranks *c c c*. These arbors

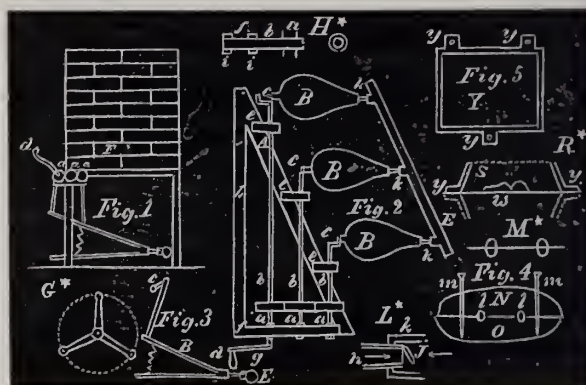

are merely rods of 3/8 charcoal iron of the right length, and to prevent end play have two collars soft soldered on as shown at *i i*, diagram *H**. The piece *f* is in half to admit the arbors *b*. Diagram *G** shows the relative position of the three cranks. In fig. 1, at *B*, is shown the position of the bellows as seen horizontally. The three bellows all lead into one pipe (*E*), which leads to the furnace, as described for the other system of blast. To prevent the air from rushing from the pipe *E*, and passing back into the bellows as they are opened, they are provided with a little valve, as show at *J*, diagram *L**. This diagram, as well as *H**, is enlarged. The arrangement must be obvious and needs no further description. The object to be gained in this arrangement is to get up a cheap melting furnace which occupies but very little space. The entire money out (saying nothing for labor) for such a furnace should not exceed four or five dollars. I mentioned in former article about casting various small articles of silver or gold. The process of casting is one capable of great delicacy, but it is one of such delicate manipulation that fine specimens of casting in gold and silver are very rare. A few general principles should always be kept in mind when attempting anything in this way. Any mold to give a good sharp casting, especially if small and fine, should be a poor conductor of heat, and should also be heated up to 200° F. Cuttle bone, from its porous nature, is very successfully used, but it is difficult to get a cast as smooth as one would desire. By rubbing the surface of the mold with calcined magnesia this can be remedied to a certain extent. Articles to be cast are imbedded in the bone by pressing two pieces together with the model between them, when the porous, yielding nature of the cuttle bone allows any piece of metal to imbed itself into the two pieces, about half in each. A good deal of judgment is required in placing the model so as to have the two halves or parts separate readily, and leave a full, sharp impression. Few instructions can be given that will apply in more than a general sense. We will suppose

we wish to cast a very heavy plain gold ring; another ring something heavier than the one we wish to cast can be used as a model. Two pieces of cuttle bone are selected and flattened by rubbing on fine sand paper, laid flat on a board, until the surfaces come true together. If now the ring is inserted between the two pieces, as shown in fig. 4, where *NO* represent the two pieces of cuttle bone, and *ll* the ring after the two pieces are pressed together and the ring imbedded half in each; *m m* represent two dressing pins which serve to hold the pieces *NO* together and in place after the ring is removed. When the ring is taken out and the two pins are placed together, a small groove is made leading to the cavity left by the ring, through which the melted metal should be poured. By fitting two pieces of cuttle bone together as described, and cutting the form of any object you wish to cast into one or both of the pieces, many little things can be cast into very near the form required, so that a trifle of filing and fitting will finish them. Charcoal fitted together in the same way can be used to carve out into molds of various shapes to cast into. The charcoal should be of soft wood, and another precaution taken to heat the charcoal mold in a stove oven until it is up to about 200° F. This will make a great difference in regard to the facility with which the metal will flow into the finer parts of the mold. To make a mold of fine sand is in all respects about the best, or, in lieu of sand, pulverized pumice stone mixed with about three per cent. of pipe clay—any clay which has not too much sand incorporated with it will answer. Fire clay, pulverized very fine, does well. The pumice stone and clay should be mixed by sifting through a sieve, repeating the operation several times. The sand or pumice stone should be moistened with a solution of rock-candy in water until it is damp enough to pack. The patterns from which you are to cast from can be of metal or wood, hard wood being the best. A metal (brass is on many accounts the best) pattern comes freer from the sand than wood, and every other way works more desirable. Molding is a trade by itself to do well and expeditiously, but still it can be mastered by any ingenious metal worker, so as to be able to make fine castings in silver, gold, or brass. A person who desires to cast any little thing had better go to some iron foundry and see the molders at work, and get at the manner in which the sand is manipulated, and how the wooden boxes into which the sand is packed. Such a visit would be worth pages written about it. After the pumice stone mold is made (using the mixture of pumice stone and clay moistened with rock-candy water), it should be dried in an oven to expel the moisture, and the metal poured while the mold is hot; this last feature is an essential element in fine castings. Some workmen may ridicule the idea of casting for jewelers' work; to such I would beg to say that for some purposes castings of both gold and silver can be used to good advantage. No doubt but to a certain portion of my readers many useful applications of fine castings will suggest themselves. For such castings as jewelers would use it is best to make use of flasks made of cast iron—flasks are the boxes into which the sand or other material is packed for copying the model or pattern. Cast iron flasks are more necessary when the molds are dried out, being less affected. At fig. 5 is shown such a cast iron flask. A pattern made of $\frac{1}{4}$ -inch wood and 6 inches square and 2 inches deep would answer for anything a jeweler would require. At *Y*, fig. 5, is shown a plan of such a flask, and at *R** is a vertical section of the same. There are lugs cast on the flask at *yy y*; through these go steady pins for resisting the two halves. These cast iron flasks are in fact only cast iron boxes without any bottom. In the diagram at *R**, at *w* is shown a pattern or model, and the surrounding space at *s* is filled with sand; the dotted lines below represent the other half of the flask. Of course the reader will understand that but one pattern (for flasks) is necessary, as all flasks cast from such pattern would unite. If sand is used for molding, the kind to be used is what founders know as Troy or Waterford sand. This can also be mixed with the rock-candy solution to bind it together when it is dried out. The dried out molds of sand or pumice stone should be used hot; hot as the hand can bear. Cal-

cined magnesia makes a very fine mold, but it is difficult to manage, and must be used dry; probably magnesia will produce the finest casting of any substance, but it requires a great deal of practice. To illustrate casting in sand, which is very much like any other material, we will suppose we have something we wish to cast: we brush the pattern over with black lead until it shines like a new stove; then lay it flat on a board, say on the dotted line *w*, diagram *R**; now fill the space *s* with sand moistened with rock-candy water, and pack the sand as firmly as possible, filling the flask full (and more) to the dotted line above *s*; scrape off the sand even with the dotted line, and turn the flask bottom side up, leaving the pattern in; now put the opposite half of the flask on and unite the two halves by the guide pins in *y*, and pack sand in this half of the flask; after the sand is firm scrape off the surplus; open the two halves, take out the pattern and provide some inlets for the metal; dry out the water and while hot cast your metal.

Proceedings of the Horological Club.

A DISTINGUISHED BODY OF WATCH AND CLOCK MAKERS.

One hundred and thirteenth discussion.—Communicated by the Secretary.

[NOTICE.—Correspondents should write all letters intended for the Club separate from any other business matters, and headed "Secretary of the Horological Club." Direct the envelope to D. H. Hopkinson, Esq. Write only on one side of the paper, state the points briefly, mail as early as possible, as it must be received here not later than the eighth day of the month, in order to be discussed and reported in the CIRCULAR for the next month.]

HOROLOGICAL SCHOOL AT GLASHUTTE.

Secretary of Horological Club:

Will you kindly inform me as to what the cost of a three years' course at Mr. Moritz Grossmann's school at Glashütte, Germany, amounts to, and whether you think it the best school?

By so doing you will greatly oblige,
Peru, Ill.

Yours,

M. E. SCHMIDT.

Secretary of Horological Club:

I would like to ask the Club a few questions. What would be the whole expense of going through the horological school at Glashütte, Germany, including fair board, etc.? If they thought a fellow without a trade could earn enough before he got too old to go? If they thought W. F. A. Woodcock would be willing to lend me said amount if I could prove I was honest and steady? And if I should fail in this, and no friends, what would you advise me and all the rest in my place to do? Hoping to receive an honest reply, I am,

Respectfully,

AMBITION.

Mr. Horologer did not know the cost of a course of instruction at Glashütte, and the price of board would vary with the style and conveniences required. The best way would be for those desiring such information to write directly to Mr. Moritz Grossman, Glashütte, Saxony, stating just what was wanted on all points, and asking the cost of such a course or such accommodations. Postage was very low, and communication so rapid, that it would be not only the surest but also the easiest and quickest way to obtain exact knowledge concerning the matter.

His school is considered one of the best for those wishing to acquire a thorough and practical knowledge of the watchmaker's trade. There is also another excellent school at Geneva, Switzerland, and one at Paris, with which he believed the renowned M. Saunier was formerly connected. There were doubtless other good schools, of which he had no knowledge.

As regards obtaining money from Mr. Woodcock to carry him through a course, only a personal application to that gentleman could settle that point. But, failing in the effort to get assistance of that kind, the best thing for boys who have real mechanical talents, good habits, industry and perseverance, is to apply to some machinist for a position as apprentice. There are more chances for successful careers in that business, ten to one, than in ours. Real

ability will do far better in almost any mechanical trade than in that of watchmaker, where it is very poorly paid at the best.

THE UNIVERSAL WATCH.

Secretary of Horological Club:

At the present day, when railroads, the telegraph and telephone, have caused distances to disappear, it is often very annoying to take into account differences of time between different places. Especially is this the case where, as in the United States, the limits of one country include places differing in local time by one, two, three and four hours. So great has the annoyance from this source become, that during the last few years several projects for obviating the difficulty have been brought forward. However well a watch may perform all that is required of it at home, a day's journey eastward or westward brings us where it must be re-set before it will show the local time. The exact amount the hands need to be moved is commonly learned when a reliable timepiece can be seen after arrival, or perhaps by consulting some book. When traveling, moreover, there are trains to catch and appointments to meet; minutes take on an unusual value, and it is more essential to have the exact time even than when at home. Also when not traveling it is often necessary for the business man to know the local time of some distant city. In telegraphing between New York or Boston and Chicago, St. Louis, or San Francisco, it is essential to be able to find out, at any minute, what time it is in the distant city in order to determine how early a dispatch must be sent, or how late it may be sent, to arrive before a fixed hour, as the closing of an exchange or the opening of a public meeting.

An appliance for a watch which enables it to be instantly set to the local time of any required city, has recently been patented by Mr. Fritz Schultz, of Carver, Minn., and is represented in the accompanying figure. In place of the inner back of the case is fixed a second dial plate. On this plate is described a spiral along which are arranged the names of cities whose local times it is desired to know, at distances apart corresponding to their respective differences in time. A hand is arranged to move over this dial and is turned, in conjunction with the other two hands, by means of the watch key. If the watch is keeping Washington time, for instance, and it is desired to know what time it is at St. Louis, the hands

are turned until this third hand has moved from the Washington mark on the spiral around to the St. Louis mark. The hour and minute hand will then indicate St. Louis time. In the case of cities which are very great distances apart, the third hand following the spiral will need to be turned several times around, and the hands at the face of the watch will move over the space of as many hours.

If, as has been proposed, a standard or normal time, say that of Washington, comes to be used over the whole or any large section of the country for the running of trains or other purposes, a watch with this attachment, whatever local time it may be keeping, can always be easily set to the standard time. The invention also furnishes a means of calculating how far a given city is west of any other. Around the edge of the plate in the figure will be noticed a circle divided into sixty equal parts. The number of these divisions passed in following the spiral from the name of one city to that of another is the number of minutes by which their times differ, and each minute indicates a progression eastward or westward of thirty-two miles.

The number of names of cities on the plate must, of course, depend on the size of the watch. On one of the size of the above cut fifty may be put. This is sufficient for the United States and Canada. Other plates may have only a few American cities, and the important European cities. Others can be made exclusively for Europe, or for the extensive British possessions, and others can be arranged for the most important cities of the world. This invention can be applied also to stem winding watches and to large clocks. On the latter the plate bearing the spiral is placed in front of the middle part of the face.

Mr. Uhrmacher said the method of finding the correct time at any city named on the dial was ingenious and convenient, but in order to do that it was necessary to lose the time on the standard or front dial, by turning those hands with the one at the back. To be sure,

they could then be turned back again to obtain the time of the original place, but that could not be done with exactness—probably not nearer than a quarter or half of a minute. Besides, frequent turning of the hands backward and forward is always objectionable, at least in fine timepieces. It would be a good idea, therefore, for Mr. Schultz to arrange some means to indicate the time on the back dial, without disturbing the positions of the hands in front. Thus equipped, a watch would be extremely useful to all travelers and business men.

MARTIN'S NEW WATCH OILER.

Mr. Clerkenwell then exhibited the above named tool. It consists of a glass handle, for containing the oil, with coin silver mountings at the ends. In one end is fixed a long, slender, hollow tube of spring steel. The oil flows from the reservoir to the end of this tube by capillary attraction, and is there delivered upon any object by touching it with the point of the tube. There are no valves, springs or mechanism, but the whole operation is performed by the capillary attraction of this fine tube. The manufacturers, Messrs. Nordman Bros., of San Francisco, state that it will divide a drop of oil, and deliver a one-five-hundredth part of it upon the pivot, and that it delivers an exactly equal quantity every time. More can of course be put on by touching the pivot as often as may be desired. It is sold at \$1.25 each, with a neat box, and seems to be a desirable addition to the list of watchmaker's conveniences.

ABOUT TELEPHONES.

Secretary of Horological Club:

I take the liberty of asking you to post me, if you can, about telephones. I have been selling the Elgin, but want something larger; have tried one of L. G. Tillotson & Co., but it is a sham. I want one that will work $\frac{1}{2}$ mile or more, and have magneto call bells. Have seen Bennett's advertised for \$15 a pair, with bells, but can get no answer from them. I have a circular of J. B. Holcomb & Co., but they are too high-priced, \$15 per pair for the instruments and \$15 more for the call bells.

If you could put me on the track of something similar to enclosed card, with bells, for about \$15 a pair, I would be greatly obliged.

Yours, respectfully,
M. L. MERRIMAN.

Copenhagen, N. Y.

Mr. Electrode said that the writer seemed to have already tried all of the principal mechanical or acoustic telephones before the public. There was a new one advertised by Wm. J. Bowen, Norwalk, Ohio, who claims great advantages for it, but we have no knowledge of its value. Mr. M. could easily obtain a circular from him. The speaker's preference was for the magneto telephones, and if Mr. M. failed to find something satisfactory in the acoustic line, he had better try this kind.

ABOUT 18-K. GOLD.—ERROR CORRECTED.

Secretary of Horological Club:

In the August number of THE JEWELERS' CIRCULAR, on page 212, is an article ("Advice to Watchmakers' Apprentices"), in which the author says: "A good composition for 18-k. is, if we use pure gold, 18 dwts. gold, 2 $\frac{1}{2}$ dwts. silver coin, 3 $\frac{1}{2}$ dwts. copper. If we use, say, a twenty dollar gold coin weighing 516 grains, we have 464.4 grains pure gold, 51.6 grains alloy (equal parts silver and copper), to which must be added 40 grains copper and 23 grains silver, producing the same alloy as above." This is hardly correct. Adding the amounts of alloy as given, we have gold 19.18+k. fine. We should add, instead, 38.7 grains of silver and 64.5 grains copper. As the article might mislead some, I thought perhaps you might wish to correct it.

Respectfully yours,

ROBERT B. HOLDEN & Co., 13 Hanover St.

Providence, R. I.

CLEANING AND OILING CLOCKS.

Secretary of Horological Club:

I send you a clipping from a newspaper on the subject of oiling clocks. Do you endorse it as correct? AMATEUR.

"Sometimes a clock is pretty clean and stops, owing to the oil getting thick on the actions; here even persons in the trade blunder in trying to remedy this evil by adding a new supply. The best thing to do in such cases is to apply some common paraffine oil with a feather; it possesses the property of blending with the thickened



oil and so restoring it, but if the amateur has cleaned a clock by my first method, I would advise him to apply no oil to the actions if the clock will do without it, for oils are only temporary in effect, and, applied to mechanism, soon thicken with dust and dirt produced by the friction of parts themselves, be they ever so well screened from outward influence. I have an American clock going without oil and badly screened; it stands on a kitchen mantel-shelf, amid much flying dust and smoke. When it stops from dust, etc., I have only to blow the bellows smartly through the works, give them a careless brushing, and she is clean again, and goes as well as ever. Had the actions been oiled this little artifice would doubtless have been useless."

Mr. McFuzee read the extract, and said it was first rate as far as it went, but it didn't go far enough to touch the spot. In fact it almost stopped before it started, so to speak. Now, anybody could see that it would be impossible to get on oil enough with a feather; that is, enough to do any good. You should get a locomotive engineer's oiling cup, holding a quart; then you could hope to do some execution. You could stand outside and squirt it in where it would do the most good, without taking the clock to pieces, which would be a great saving of time and botheration. The idea of blowing the dust out with a pair of bellows was equally short-sighted. It might carry off a small part of the dust, but the best portion of it would still be on hand ready for business. To make a thorough job of it, get a strong piece of steam hose, lay it from the boiler of a steam engine to an opening into the clock case, and turn a full head of steam through the running gears and things for a few minutes. There would be some sense in that, for it would make a sure thing of it. What is the use of doing things half way anyhow? If you are going to fix a clock, don't try bellows, and feathers, and such antiquated ways as that, but employ modern scientific labor-saving apparatus, and do a job worthy of the advanced civilization of the age we live in.

Sight.

WHAT THE OPTICIAN SHOULD KNOW ABOUT OPTICS.

Based upon an extensive hospital experience in Austria, Germany, England and New York. By C. A. BUCKLIN, M. D., New York. Author of Detection and Correction of Visual Imperfections, Cause and Cure of Cross Eyes, Effects of Color on Distance, and Monograph on Astigmatism.

Continued from Page 250.

IT MUST be supposed that the opticians of the country do not find so many perplexing phenomena in fitting troublesome cases with spectacles as they formerly found. For a long time the inquiries were very intelligent and to the point, but now they have ceased to ask questions. I am somewhat surprised that deviations of the eye *in or out*, commonly called squint or cross-eyed, have not attracted more attention.

The readers of THE CIRCULAR must remember that any information they desire on the subject of sight will be cheerfully furnished. I have at last, through the kindness of Miller Bros., of this city, obtained a very good wood cut of an ophthalmoscope, which I publish in this number, with a description of the same.

OPHTHALMOSCOPE.

It consists of a frame holding a concave mirror perforated in its center. The mirror in the cut is turned from you. Behind this mirror is a disc the margin of which is perforated with small holes containing a collection of concave and convex lenses. The axis of this disc is so situated, that as the disc revolves the perforations in it containing the lenses come opposite the opening in the mirror. At the side of the ophthalmoscope is a simple disc which is used as a covering to the lenses to exclude dust and dirt. When this disc is applied to the ophthalmoscope the upper opening allows one to look through the mirror, while the lower opening displays the number of each lens as the disc revolves. There is also a handle to the instrument about four inches long.

To examine the right eye of the patient he is directed to look at

some distant object which is a few feet to the left of a line passing straight from him. The light is slightly behind and to the right of him. Take the ophthalmoscope in your hand and reflect the light from the lamp into the pupil of his eye; at a little distance you will simply see a red reflex, but if the little dark shadow caused by the opening in the mirror be brought to bear on the dark pupil, and the instrument be brought to within half an inch of the person's eye, a bright clear image of the optic nerve and blood vessels supplying the retina will be seen. To examine the left eye, the position of the lamp and the direction of the person's glance is simply changed.

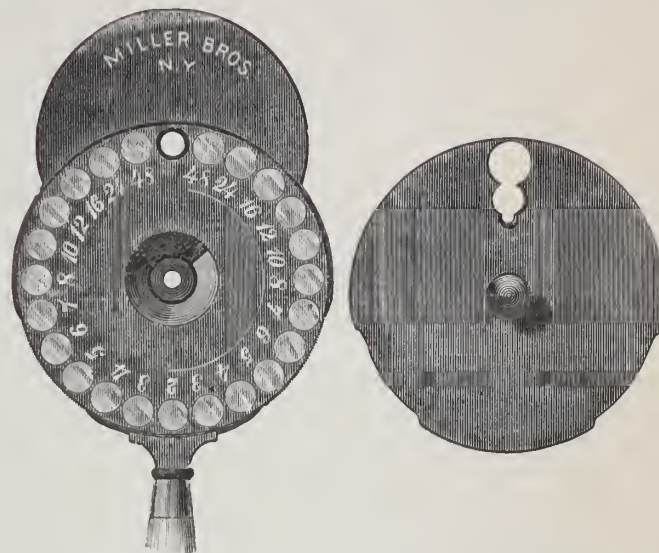

If your eye is not normal a proper glass should be placed behind the instrument to allow for the defect of your own eye. If your eye is normal and you require a convex glass to see the optic nerve distinctly the strongest convex lens through which you can see the fine blood vessels distinctly represents the amount of far-sight the person has. It will be the number of convex glass required to cure weak vision if it exists, or it will be the glass required to cure a child's cross-eye, if the trouble be curable by glasses. In small children the question of glasses can be settled by the ophthalmoscope, independent of the statements of the child. If concave glasses are required, the weakest concave glass through which the small vessels can be seen distinctly is the glass which will be required for the distance. With practice one may become very expert in the use of the ophthalmoscope as a measurer of visual imperfections. Those who simply wish to examine the eye, to detect diseased conditions without regard to the refractive condition, usually hold the ophthalmoscope at about fourteen inches from the eye to be examined, and place a convex No. Ten lens behind the instrument. To examine the left eye direct the person to look at your left ear, your position being straight in front of the person examined. Throw the light in the pupil from the mirror as directed before; when you see a red reflex place with your other hand a 2½ inch convex lens *about* one inch in front of the observed eye, and while moving this lens backward and forward slightly, observe the red reflex and you will soon see a clear inverted image of the retina. This method can be carried out very rapidly with practice, but it does not detect and measure errors of refraction.

Views of Correspondents.

This department of THE CIRCULAR is open for communications relating to the jewelry trade, but the editor does not hold himself responsible for the sentiments expressed by contributors. We invite correspondence, but require that it shall be free from all personalities, and the writer's integrity guaranteed by the disclosure of his true name to the editor. Anonymous communications will not be noticed.

DUTY ON PRECIOUS STONES.

To the Editor of the Jewelers' Circular:

I wish to know the duty imposed by the Government upon precious stones, such as garnets, pearls, opals, etc. J. E. M. Alledo, Ill.

[A duty of 10 per cent. is levied upon all precious stones imported into this country, and 50 per cent. upon beads strung or unstrung.—ED].

HOW TO STOP TRAVELING AUCTIONS.

To the Editor of the Jewelers' Circular:

"H. C. H.'s." complaint in the October number of THE CIRCULAR is just, and this may help him, if not rid him, of the nuisance entirely. I enclose a copy of a law of our State, which I fathered last winter as a member of the Senate.

The village trustees, or the city council, can make the "traveling auctioneer" give bonds—pay his license, \$150, and pay his five per cent. on sales. If "H. C. H.," and all merchants who are interested in legitimate business, will talk to their members of their own State Legislature, we can have a law of this kind in every State in the Union:

SECTION 1. Section 1,590 of the revised statutes is hereby amended so as to read as follows: Section 1,590. The common council of any city and the board of trustees of any village, are authorized to regulate uniformly, by ordinances passed according to law, the sale by auction of goods, wares and merchandise, or other property, within their respective cities or villages; and thereby may prohibit, under proper fines or penalties, any sales at auction therein by any person without license, and require quarterly or monthly reports, verified by affidavit, to be made by every auctioneer to the municipal clerk, and require sufficient bonds from the licensee for compliance with any such ordinance, and require the payment of a license fee of not less than five (5) nor more than one hundred and fifty (150) dollars per year, in addition to any percentage they may fix, not exceeding five per centum upon the gross amount of sales made; but they shall not require the payment of any duty in the cases excepted in section 1,585.

SEC. 2. This act shall take effect and be in force from and after its passage and publication.

Approved March 27, 1883.

Milwaukee, Wis.

WM. S. S., JR., of S. & C.

A MIXED STOCK PAYS.

To the Editor of the Jewelers' Circular:

I have been east to buy my fall and winter stock. I have also concluded to try your proposed plan of carrying a mixed stock of goods, and I must say that I am well pleased, for I now sell many goods that I heretofore would not sell at any price, at good profits, and I think it is a good idea, and would advise all my country brethren to try it, and I know they will be highly pleased.

Yours very respectfully, FRED G.

Somerville, Tenn.

To the Editor of the Jewelers' Circular:

Through the columns of THE JEWELERS' CIRCULAR I would like to say a few words to Brother R. O. U. in answer to his communication in the September number. Some time ago a gentleman came to me and showed me his plain gold ring, which he bought some eighteen years ago as a wedding ring. It was black as coal, and to clean it I had to go through the same process as if polishing a new ring. This is the first time that it ever turned black. He was very much worried, but upon questioning him, I soon found out that he had been taking calomel for several days. Now it must have been the cause, as he had worn the ring eighteen years and it was the first time it happened. I have frequently sold watches (gold and silver), and in a few days the customers would come back and want to know why their watches got so black. I asked them if they had matches in their pockets, and upon looking it was the case. Now they thought they had been swindled. If Brother R. O. U. will show this answer to his customer, I think he will be satisfied.

I would like, through the columns of THE JEWELERS' CIRCULAR, to throw a hint to the manufacturers of nickel clocks. I have never received a lot that I did not have to do some repairing before I

could sell them. Some had the hour hand in the wrong place, that is, between the hours; some had the balance wheel hanging from between the plates, when by tightening the screws a little, they would not be in such a fix; some the alarm hand does not agree with the time hands. Now to remedy all this I have to take the entire clock to pieces, and while doing this I could clean a watch; moreover, the profit on them is so small that it scarcely pays to handle them, not alone repair them, before selling. I am of the same opinion as you are in regard to the Aurora Watch Company, and think that your remarks *just hit the nail on the head*. I would state that one of the most active men in the concern, who was in the jewelry business and issues no catalogues but circulars, with illustrations and net prices attached, and says in his advertisement (to the trade only), but to-day I saw a letter written by him to a druggist of my town, asking him to let them send him a selection package—now don't that beat catalogues. If any brother wants to know who he is or who the firm is, I will cheerfully inform him by addressing me.

Wishing THE JEWELERS' CIRCULAR success, I am as ever,
Bayou Sara, La. GUS BROWN.

Problems in the Detached Lever Escapement.

BY DETENT.

WE WILL now consider the laying out of our pallets with equidistant locking faces, drawing first the pallets at exactly the right angles, and then describe how to make the pallets adjustable, so as to use them as circular ones by changing the parts which represent the pallet jewels. I described in my last article how to establish the center of the pallet action. In fig. 1, at *a*, will be seen a tooth resting on the pallet; this pallet is called the entrance pallet. As I remarked early in these papers, we shall consider our pallets as having 10 degrees pallet action. We have laid out at fig. 2 one arc of 60 degrees (the radius of our scape wheel) and divided it so as to get degrees. We take 10 degrees in our dividers, and letting our point rest at the point of the tooth *a*, lay off 10 degrees on the circle *b d*, which represents the circle of the tips of the scape wheel teeth, and draw the line *c e*. Now the point on the periphery of the scape wheel where the line *c e* crosses is exactly where the tooth *a* of the scape wheel will leave the entrance pallet; after the tooth *a* leaves the pallet, it falls 2 degrees farther until it reaches the part indicated by the dotted curve *f*. This fall or drop is allowed to make up for the inaccuracies of construction, and also to clear the back of the tooth. If we draw a line from *k*, the center of the pallet action,

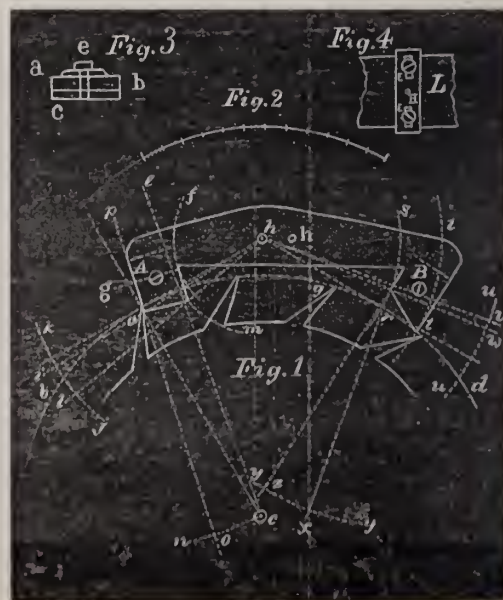

through where the line *c e* crosses the circle *b d*, we shall establish the line *h i*. We now take our scape wheel radius and sweep the circle *k j*; we next take 10 degrees from fig. 2 and lay off 10 degrees

from i , on the curve $k j$, and establish the point l . Draw the line $l h$, and where this line crosses the circle m , will be located the inner angle of the entrance pallet. We next set our dividers on the point of the tooth a , and with radius in our dividers sweep the circle $c n$; on this circle we lay off 12 degrees from c to o , and draw a line from the point of the tooth a to o , continuing the line outside of the circle $b d$ as shown. This line defines the locking face of the entrance pallet and gives the pallet about the right amount of *draw*. The locking face of the pallet should extend about 2 degrees inside of the circle $b d$, giving the actual impulse face of the pallet 8 degrees. Some escapement makers give less lock and some more; but in actual practice it will be found that the locking face embraces three or more degrees; but if anything like well made pallets are used, 2 degrees lock is enough. The line $i h$ corresponds so near to the space, that we will assume that it is 2 degrees from the line drawn from the point of the tooth a to h . If a line is drawn from where the line $a o$ intersects the line $i h$ to where the line $l h$ crosses the circle m , we define the impulse face of the entrance pallet. We continue the line $a o$ to p , and we have the locking face of the entrance pallet; we draw a line parallel to this from where the line $c e$ crosses $h l$, and we define the inner face of this pallet. To define the exit or egress pallet, we take our radius ($a c$) and establish the point r on the periphery of our scape wheel; this embraces $2\frac{1}{2}$ teeth. We next take 10 degrees from fig. 2 and establish the point t on the circle $b d$; this point (t) locates the extreme angle of the exit pallet. We now draw the line $h r$, extending it beyond r as shown. We again take radius in our dividers and sweep the circle $u u$; we next take 10 degrees in our dividers and from where the line $h r$ (extended) crosses the circle $u u$, lay off 10 degrees to the point v and draw the line $v h$. We now take 2 degrees from the arc u and draw the line $h w$. We now draw a line from the point where the circle $r s$ intersects the line $h w$ to where the circle $t t$ intersects the periphery of the scape wheel $b d$, and define the impulse face of the exit pallet. We next draw a line ($r x$) at right angles to the line $h v$; by the rule given in October number of this journal, and with radius in your dividers, set one leg on the point where the line $h v$ intersects the circle $r s$, and sweep the circle $y y$, and lay off 12 degrees on this circle, as shown, and draw the line $r z$, and it defines the locking face of the exit pallet; draw a line parallel to it and it defines the outer face of this pallet as shown. The shape of the pallets, aside from the forms given, is a matter of taste. We have now the forms of scape wheel and pallets delineated in a correct manner, and it only remains to realize them in brass and steel. In making such a model as has been described, it is well to make the pallets of No. 16 brass; take a piece large enough to lay out the work as described, then saw out the pallets to near the form, then file and finish to exact sizes. In cutting out such work with a saw, it is well to go over the outline of the work in hand with a graver, defining the piece you wish to cut out with stronger and deeper lines. Any person who will try filing to a line cut with a graver in comparison to one simply scratched, will soon take the extra trouble to *outline* with a graver. The portions of the pallet arms below the dotted lines shown at $A B$, fig. 1, would be best made of steel and secured by screws as shown. The pieces $A B$ should be about $\frac{1}{8}$ of an inch thick and shaped as shown. The hole through which the screws go should be larger than the screw and have a washer between the screw head and the pallet. At fig. 3 is shown a vertical section of the pallet A , fig. 1, on the line g . In this cut (fig. 3) e represents the screw, a the washer, b the pallet, c the brass pallet arm. This system of arrangement will enable you to solve practically many of the problems in the detached lever escapement. The brass piece C should be cut to the exact shape of the correct pallet form, or have the form delineated on it and graver outlined, so that we can judge accurately of any change in the manner of setting the pallet. In making the model it is well to make the pivot holes in which the scape wheel pivots run so they can be set further away or closer to the pallets for the sake of experimenting with the depths between

the scape wheel and pallet. This can be done by fitting a slide on the bridge over the scape wheel, shown in cut in September number of this journal. The manner of making the slide is shown at fig. 4, where L represents the bridge, and II the slide with two screws $E E$. The board on which the model is mounted should also have a slide arranged in the same way, so as to keep the scape wheel arbor upright. We have got now so we can begin to consider the problems which are the great object of these papers. We are often told that some things are all right in theory, but will not do in practice. Now this is all nonsense. If the theory is sound, *i. e.*, based on correct principles, the practical part must come, the great obstacles to be overcome being mechanical imperfections. Here we have the opportunity to mechanically test our theories. Suppose we set our scape wheel so that we know that the depth is too shallow with the pallets, by moving the slide described above, then set the steel pallets, which move on the screws $A B$, so as to be equivalent to drawing out the pallet stone, and see how the motion compares with the motion when we know the pallet action is as it should be. The steel pallets $A B$ should be hardened and the locking and impulse faces polished. The writer has not the space in this article to give the rules for drawing and making the fork and roller action, consequently must put this over to our next article, as it seems to be sound policy to let each lesson complete such portions as seem complete in themselves, as, for instance, in this article we have described the method of drawing a ratchet toothed lever pallet with equi-distant locking faces. We would suggest to the student, after he has drawn the present escapement—a moment's digression—the watchmaker who wishes to become perfect in his art should *draw* it, not merely read and understand it, but go at it and draw it out just as described. It is a good deal for this reason the writer simplified the rules and got the drawing instruments down to three—a pair of dividers, a straight-edge and a needle scratch point. A piece of zinc, such as people put under stoves, is an excellent thing to draw on with the above mentioned instruments, and for accuracy a metal surface is a great deal more exact and accurate than paper. As a problem to be solved, I would ask how will it affect the locking and impulse angles if the center of pallet action should be changed from h to n . Let the pupil draw the escapement with this change, and if principles given above are understood, the pupil can delineate the pallets so as to have a locking angle of 12 degrees, a locking face of 2 degrees, and an impulse face of 8 degrees action after the center is changed from h to n .

Depthings.

[By J. RAMBAL, teacher of Horological School of Geneva, in
Allg. Journ. d. Uhrm.]

Continued from page 277.

II.—PRACTICAL PART.—(See Illustrations in No. 9).

CONTENTS:—15. The height of the addendum is a part of the pitch diameter of the driven pinion. Explanation of the sketched depthing. 16. Determination of the dimension of a pinion. Three methods generally employed for this purpose. 17. Plan for altering the third method. Table of the intervals, which correspond to the different numbers of the pinion leaves. 18. Small change according to the proportions of the number of teeth and according to the form of the rounding of the pinion leaf. 19. Test of the activity of the depthing. Utility of large models.

15. According to this method a greater security is therefore obtained without enlarging the pitch circles, as has been proposed by Camus. Again, with the altered curve, all dimensions of wheel and pinion may be calculated with as great an exactness as by the use of the epicycloid, provided that the height of the addendum is known. This proportion is, for the same number of pinion leaves, always the same, and decreases in the ratio with the increase of the number of leaves.

Next follow the statements for the depthings represented in figures

11, 12, 13 and 14, and, beside this, those for a 10-leaf pinion, such as they have been, obtained from sketches on a large scale.

Wheel.	Pinion.	Strength of the wheel teeth (expressed in fractional parts of the division).	Height of the addendum (expressed in fractional parts of original radius of pinion).	Proportion between the full dimensions of wheel and pinion.	Radius of the changed curve of the addendum (expressed in fractional parts of the division).
60	6	0.573	0.512	8.95	0.573
70	7	0.564	0.456	9.096	0.606
80	8	0.549	0.406	9.2	0.720
80	10	0.527	0.347	7.556	Epicycloid.

From pinions of 12 leaves downward the strength of the wheel tooth may be taken as equal to the interval, the driving thereby ends a little before the point of the tooth. Already from a 10-leaf pinion on, the epicycloid may with full confidence be reassumed; it might safely be used yet for pinions with 8 leaves (figure 10), because the commencement of the driving would then take place about 7° before the line of centers, and would therefore be a little less than half the thickness of a leaf. Beside this, this latter quantity may still be decreased somewhat, if the strength of the tooth is made according to the dimensions of above table.

The employment of the altered curve would therefore be limited to pinions with 6 and 7 leaves.

16. In practice it is often necessary to determine the dimension of a pinion which is to correspond to a given wheel.

This ascertaining can be performed in several manners with greater or less exactness. The surest way to establish the size of the pinion is by calculation, by which the result may be verified with a gauge provided with vernier.

For instance, the size of a pinion with 6 leaves, which stands in depth with a wheel of 60 teeth, is to be calculated. Let us assume that the wheel has been measured as containing a diameter of 5.2 millimeters. If this sum is divided with 8.95, therefore with the proportion in which the dimensions of wheel and pinion should stand to each other, according to column 5 of the preceding table, 0.58 mm. is obtained as diameter of the pinion.

17. We propose another method:

1. To take the point of the tooth as starting point for the measurement; and, 2. To designate by the appellation of *interval* the distance from one tooth point to the other, and to determine furthermore the whole units as well as fractional parts of intervals, which form an arc, the chord of which corresponds to the desired diameter of the pinion.

If the roundings of the pinion leaves are semi-circular, then the diameter will correspond to the following number of intervals:

Pinions with	Wheel of	Intervals.
6	60	2.15
7	70	2.455
8	80	2.77
10	80	3.38
12	96	4.07

If, therefore, it is necessary to measure a pinion of 6 leaves, the pinion gauge is to be placed upon the point of a leaf, and from thence 2.15 intervals, or a little more than the distance between three adjoining leaf points, is to be spanned.

18. These ratios alter, even if only a little, as soon as the proportion of the tooth number of wheel and pinion changes from that in above table; this difference becomes most noticeable in the case of many-leaved pinions, because they embrace a greater part of the wheel circle. For a wheel with 48 teeth for instance, a 6-leaf pinion must measure 2.125 interval, therefore only a very little less than the amount for 60 teeth given in the table.

For the case that the pinion leaf, instead of ending in a semi-circle should have a somewhat elongated form, the above given distances are far too short. Such a pinion will easily appear too large, while it is proportioned to the requirements of the wheel, since the rounding alone has been altered; its pitch radius, also, is in as correct a proportion as with the semi-circular rounding. The pinions of English watches, which to us appear too large, are based upon this system; the barley corn-shaped leaf shows a rounding of a very elongated form.

19. It is very difficult to judge of the depthings in watches, in consequence of the very short distance for which the two parts remain in contact. In order to obtain a thorough knowledge of this process it is advisable for the student to provide himself with models, which must be manufactured on a sufficiently large scale that the irregularities inherent to them exert no influence upon the result.

Such models are generally constructed of wood or zinc, since they are rather costly, wherefore their use is generally confined to horological schools. It would, however, be of a great advantage if the young workmen were to procure a set and study its effect.

(To be Continued.)

Watch Trials at Neuchatel.

FROM THE Report of Dr. Hirsch, Director of the Neuchatel Observatory, we learn that 306 watches were deposited there for trial during 1882. Leclle contributed 118; Brenets, 40; Chaux-de-Fonds, 35; Neuchatel, 19; Fleurien, Ponts, and St. Imier, 2 each; Ste. Croix, 1; and 15 from foreign countries. 234, or 77 per cent., obtained certificates. Of these, 30 were first-class certificates, the watches being observed for six weeks in five positions, showing an average mean daily variation of 0.48 sec. 114 were second-class certificates, the watches being observed for one month in two positions, with an average mean daily variation of 0.52 sec. 90 were third-class certificates, the watches being observed for fifteen days in one position, and at ordinary temperature, with an average mean daily variation of 0.57 sec.

The mean daily temperature of—

191 watches with lever escapement	was	0.52 sec.
39 " pivoted detent	"	0.66 sec.
2 " spring detent	"	0.775 sec.
2 " tourbillon	"	0.425 sec.

Dr. Hirsch also gives a comparison of the results with these escapements during the last 31 years, as follows:—

	Lever.	Pivoted Detent.	Spring Detent.	Tourbillon.
Number of pieces on trial	2177	720	189	87
Average mean daily variation	0.576	0.681	0.602	0.621

These figures have a special interest just now, in presence of the recent discussions as to the comparative value of the chronometer and lever escapements, though it would be idle to assume that they demonstrated the superiority of the lever. A more prolonged trial than that under notice would be needed for the peculiar features of each escapement to be detected in the going of the watches, and even then disparities might probably be due to a want of uniformity in the quality of the escapement, or in the springing; for we notice in the same report, that the only three marine chronometers deposited for trial were withdrawn because their going was not satisfactory.

212 of the watches obtaining certificates, or 91 per cent. of the whole, had balance springs with terminal curves based on the theory of M. Phillips; 9 springs were of palladium; and for the first time in the Neuchatel trials, the spherical form of balance spring, with terminal curves, deduced from the theories of Mr. J. Grossmann, Director of the Locle Horological School, was introduced.

The mean variation of watches with volute springs having Breguet terminal curves was 0.52 sec., against 0.53 sec. the mean variation of those with Phillips' curves; volute springs, with double theoretical

curves, showed a mean variation of 0.62 sec.; the Phillips' helical springs, 0.72 sec.; the ordinary form of helical spring, 0.64 sec. This, however, is a result in great measure contrary to the average of the last twelve years, which gives a mean of 0.46 sec. for Phillips' helical, 0.49 for Phillips' double curve, and 0.54 for Phillips' volute. Generally, over this period, the springs with theoretical curves have a mean variation of 0.53 sec. against 0.58 sec. for the older forms of curves.

A comparison of the ten years during which watches undergoing the trial for the first-class certificates have been subjected to observation in five positions, shows that with 184 pieces tried with volute springs having Phillips' terminal curves, the average mean variation was 7.81 sec.; with 100 pieces having volute springs with Phillips' double curve, the average was 7.77 sec.; 18 with Phillips' helical, 8.43 sec.; 17 with ordinary helical, 7.09 sec.; 20 with Breguet's springs, 11.30 sec.; 5 with spherical springs, 11.56 sec. This gives altogether for the 302 pieces with Phillips' springs a general average of the four variations amounting to 7.83 secs., against 9.62 secs. for the others. It would appear, though, that helical springs with Phillips' curves are not so favorable for position timing.

Fashions in Jewelry.

CHOICE JEWELRY and gem settings are of more than usual interest this season. These articles of personal adornment have been so arranged as to agree in tone with the great display of color effects in rich textiles. The fancy for brilliant stones of contrasting hues given on a single design is now one of the leading features in expensive jewelry. Pendants are again fashionable; among the favorite models are blossoms, and there are many fanciful devices, and not a few of the patterns are of antique workmanship. A pendant formed of a violet, the petals studded with gems, a diamond sparkles in the center. A star pendant formed wholly of opals from the size of a pin's head to a $\frac{3}{4}$ -karat stone is a brilliant ornament and wonderfully effective. Among the choice novelties in jewelry are tourmalines. One of these gems, a rare beauty of a clear deep green hue, forms the center of a pendant composed wholly of clustered gems—the topaz, pearls, diamonds, and spinals, pink and blue. The Brazilian topaz is a favorite stone this season; it is given in various combinations, and particularly is this gem showy when placed with brown spinals and olive green tourmalines with diamonds alternating. Gold lace pins are brought out in very handsome and showy patterns. The favorite shape is long and slender; the designs are quite varied, some of which possess a genuine artistic value. There are small flowers in exquisite enameling, where the natural colors are accurately portrayed; these are elaborately studded with tourmalines of various hues, spinals, blue, pink and brown, peridots, sapphires, diamonds and chrysoberyls. Lace pins are frequently used as shoulder ornaments, to fasten a lace scarf, ribbon bow, or hold in place a cluster of natural flowers. Black pearls are very effective with diamond settings; the contrast is a striking one, and wondrously showy by gas light. "Full sets" are not so fashionable now as they have been; the idea now is odd pieces, the styles in jewelry following the modes in matchless household goods and toilet contrastings in colors. There is considerable filigree work in plain gold jewelry. Indian molten gold is artistically neat with delicate tracings of leaves and scroll work. There is a great demand for bracelets; this fashion of ornament was never more in vogue than now, all owing, doubtless, to the prevailing styles in sleeves, which are worn so short that some sort of ornament is necessary to relieve the length between the hand and where the sleeve terminates. There are a number of styles presented in bracelets, the patterns showing heavy twisted wires of antique workmanship, with gems sunk in the gold. Chain and half-hoop bracelets are favorites; these are beautifully adorned with gems of all kinds; frequently there are

as many as seven or eight different kinds of stones in one setting. The extension bangles are very handy, they are so easily put on.

In rings there are shown many odd styles; real old fashions are brought forward once more in the clustering of stones; very little gold is seen around the settings; the center stone is usually a diamond, encircling which are rubies, pearls, etc., alternately, or the circlet may be composed of one kind of gem. There is considerable favoritism shown for those rings with settings of tourmalines. It is a curious fact that these precious stones are so unlike each other, those of the same shade, that a "match set" cannot be made of them. Ear rings are made to fit the ears closely; there are a few pendant styles, but the former mode is the general one. Gems composing ear rings are diamonds and pearls, although all kinds of precious stones are seen in a more or less degree. Gold collar buttons for ladies are sometimes finished with a neat setting.

Linked sleeve buttons are once more fashionable. Dissimilar buttons are shown in some of the new sets. Hammered gold links in the grotesque styles are favored. These novelties are richly set with gems. Antique Indian gold designs are extremely artistic. There are floral patterns in pierced gold links. The antique designs are chiefly composed of enamel. Upon plain links the initials or monogram is often seen. Gentlemen are wearing more jewelry than they have for many years, in fact, more than they ever wore in this country. There are for gentlemen rings of various kinds. The favorite style is a heavy circuit of gold, finished in the antique style, and set with a sunken stone, either a diamond, tourmaline, sapphire, or ruby. Scarf pins are more fashionable than studs. These pins are brought out in a variety of styles. Some of the designs are exceedingly unique. There are heads of dogs, horses, tigers, snakes, etc. These devices are gotten up in precious stones—and there are jockey caps, whips, canes and horseshoes; also blossoms of all kinds beautifully enameled, the petals studded with gems. Seals, locket and pendants are wrought in a variety of styles, and are enriched with the opaque stones, such as onyx, bloodstone, "tiger-eye," etc. The vest chains are worn in various ways; the most favored is the watch guard.

Electricity Not a Form of Magnetism.

PROFESSOR HUGHES has recently advanced views about magnetism which, if accepted, will largely modify the position which science assigns to this property. He asserts that where there is no apparent magnetism, or the magnetism is neutral, there is not, as had been supposed, an indifferent turning of the molecules in all directions, with consequent balancing of influence, but, on the contrary, there is a perfect symmetrical arrangement, the molecules (or their polarities) arranging themselves so as to satisfy their mutual attraction by the shortest path, and thus form a complete closed circuit of attraction. When magnetism becomes evident, the molecules (or their polarities) have all rotated symmetrically in a given direction, but the symmetry of arrangement is such that the circles of attraction are not completed except through an external armature joining both poles. Again, he shows that we have permanent magnetism when the molecular rigidity retains the molecules or their polarities in a given direction, and transient magnetism whenever the molecules are comparatively free. Professor Hughes also shows that the inherent polarity or magnetism of each molecule is, like gravity, a constant quantity which can neither be generated nor augmented nor diminished nor destroyed. Neither can magnetism be changed to any other form of force or property of matter. It must be, therefore, dissociated from electricity, as certainly as gravitation must be dissociated from heat and light. Electricity may be generated by magnetism just as light and heat (as is the case of the sun) may be generated by gravitation; but electricity is not a form of magnetism, any more than heat or light is a form of gravity.—*Contemporary Review*.

Soldering Without an Iron.

THE FOLLOWING method, without the use of a soldering iron, is given in *Der Techniker*: The parts to be joined are made to fit accurately, either by filing, or on a lathe. The surfaces are moistened with the soldering fluid, a smooth piece of tinfoil laid on, and the pieces pressed together and tightly wired. The article is then heated over the fire, by means of a lamp, until the tinfoil melts. In this way two pieces of brass can be soldered together so nicely that the joint can scarcely be found.

With good soft solder, nearly all kinds of soldering can be done over a lamp, without the use of a "bit." If several places have to be soldered on the same piece, it is well to use solder of unlike fusibility. If the first piece is soldered with fine solder, composed of 2 parts of lead, 1 of tin, and 2 of bismuth, there is no danger of its melting when another piece near it is soldered with bismuth solder, consisting of 4 parts of lead, 4 of tin, and 1 of bismuth, for their melting points differ so much that the former will not melt when the latter does. Many solders do not form a malleable compound.

In soldering together copper, brass or iron, hard solder must be employed; for example, a solder made of equal parts of brass and silver. For iron, copper or brass of high melting point, a good solder is obtained by rolling a silver coin out thin, for it furnishes a tenacious compound, and one that is not too expensive, since silver stretches out well. Borax is the best flux for hard soldering. It dissolves the oxides which form on the surface of the metal, and protects it from further oxidization, so that the solder comes into actual contact with the surfaces of the metal. For soft soldering, the well known fluid, made by saturating equal parts of water and hydrochloric acid with zinc, is to be used. In using common solder, rosin is the cheapest and best flux. It has also this advantage, that it does not rust the articles on which it is used.

Cameos.

THE ART of gem cutting owes its origin to the old superstition that man could render himself proof against the dangers of witchcraft and human ill-will by suspending upon his person gems and precious stones. Beside the transparent and lustrous jewels, diamond, ruby, emerald, etc., which were employed less often, we find especially the translucent and opaque ones, opal, turquoise, agate, etc., sometimes ordinary rocks, granite, syenite, basalt, etc., and animal productions, ivory, coral, pearl shells, amber, or metals, employed for the purpose. The Greeks, who had learned the art of gem cutting from the Orient, excelled in it; they adorned with cameos many dishes and vessels, and cut entire vessels cameo-like, which were of great beauty and artistic finish, for instance, the Portland vase in the British Museum in London. Also the ancient Romans, who learned the art from the Greeks, have left many pieces of a highly artistic merit. During the first centuries of Christianity, the art was chiefly followed in Constantinople, while it appears not to have been introduced into the European countries. The art was carried only in the 15th century by Greek workmen from Constantinople to Italy, where it was cultivated at the time of the Renaissance in the 16th century, and the art of cutting vessels from rare stones was practiced with the greatest artistic skill.

The cabinets of gems in Paris and Florence, the imperial treasure at Vienna, the treasure in Munich, and especially the *Grüne Gewölbe* contain a great number of these works, executed by Italian, French and German artists. In the 17th century, in the Thirty Years' War, at which time all art was paralyzed and retrogressed, also that of gem cutting shared the common fate, and with the exception of a short spasmodic rally in the 18th century, not much has been done in this line.

The art of cameo cutting is at present followed chiefly in Genoa, Rome and Paris, as an industry. While for 40 years the cutting of cameos was solely confined to Rome and Italy, Genoa entered

recently into competition, and possesses at present 30 cameo cutters, Rome 80, while it is said that in Paris more than 300 persons are engaged in it. As material for the present cameo cutting, besides jewels and shells, also lava is used. Certain kinds of univalves are peculiarly well adapted for cameos, since their substance consists of several differently colored layers, and possesses a difference of texture and hardness. The workman treats this kind of shell thus that the direction of the leaf of the central layer is seen lengthwise. By these cameos, the central layer forms the body of the relief, the lower one serves as the background, and the outer third differently colored one is used for the surface of the figure, whereby this receives a different appearance, or special framing, as it were. Of shells with three layers, the cutter picks out such in which the layers hang together, the central layer is thick, and the different colors of the three layers differ from one another, and the inner layer is of a color that is adapted to the purposes.

In cutting, the mussel or shell is, with diamond dust and a splitting arrangement, or with a steel knife and emery and a supply of water, cut in such dimensions as are necessary for the manufacture of cameos. These pieces are ground in suitable shapes—square, round or oval, and the rims are polished with oilstone; they are next cemented upon a piece of wood, which is to serve as a handle, by means of which the artist manipulates the blank work, while he draws upon it the figure or design with a needle. These strokes are traced afterward with a sharp-pointed instrument, with which the requisite contours are worked out, after which work is continued with more delicate instruments of steel wire, which is smooth and hardened at one end, and then with files and gravers, in order to remove the superfluous parts of the enamel. The surface of the cameo is elaborated as much as possible with cutting instruments, since by polishing, the sharp contours of the figure would be injured. After the figure has been cut in relief, it receives a final polish, with a little dry putty and a small stiff brush, whereby great attention must be paid not to scratch the surface. The cameo is then loosened from the handle and is ready for sale.

Soldering and Melting.

TO *hard solder* gold, silver, or other metal articles which have previously been *soft soldered*, or to melt old gold or silver for re-working, it is absolutely necessary to most carefully remove even the smallest traces of soft solder from the articles, as the heat required for hard soldering would burn the soft solder into the article, and occasion irreparable blemishes, and in melting would make the metal brittle and unworkable. It is, however, not always an easy task to entirely remove the soft solder by mechanical means such as scraping, filing, or cutting, especially when the solder has run into hollows, interstices, engravings, or chasings, which places are very difficult to be reached with ordinary tools; in these instances the following manipulation is applied with good results:

The articles to be cleaned are first heated over the flame of a lamp until the solder begins to fuse, when as much as possible is brushed off with a stiff tooth brush, the heating and brushing to be repeated until no more solder can be removed in this way; the articles are then placed in a heated solution of the following composition, which will dissolve all the remaining solder:

Two ounces of sulphate of iron (copperas) and one ounce of saltpeter are finely powdered, and boiled in a cast iron vessel in ten ounces of water, until about one-fourth of the solution has evaporated; the vessel is then set aside for cooling, when most of the solution will turn into crystals. After two or three hours, the remaining solution, not yet crystalized, is poured off, boiled again, and set by for crystalizing, and the process repeated until all the solution is thus disposed of.

The crystals are then dissolved in muriatic acid, in the proportion of one part of crystals to eight parts of acid; of this solution one part is diluted with four parts of water, heated, and the articles to be cleaned immersed therein, when all the solder will dissolve without injuring or discoloring the most delicate piece of work.—*Allg. Uhrm. Ztg.*

Some Things of Old Spain.

A TRULY Oriental custom existed in those days, which was often attended with much inconvenience. If one inadvertently praised any article belonging to another, the latter was bound to urge its acceptance on the admirer. The Countess Danois chanced to compliment Don Antonio of Toledo, son to the Duke of Alva, on the beauty of his harness, which was of an Isabella color. He replied that he laid them at her feet, and that same evening she was informed that his six horses were in her stable, and it was with great difficulty that she induced him to take them back again. She herself, at the very outset, had a disagreeable experience of this custom. She was in the habit of winding up her watch at noon, the ordinary dinner hour, and one of her women brought it to her as usual for that purpose. It was a striking watch of Tompion's make, and cost fifty louis d'or. Her banker, who was seated beside her, expressed curiosity to look at it. Whereupon she handed it to him with a few words of civility. To her dismay he rose, made her a profound reverence, avowed his unworthiness to receive such a favor, and protested that he would never part with the watch under any circumstances. He then kissed it, and dropped it into his capacious pocket.

In the matter of jewelry Spanish ladies were very extravagant. Precious stones, however, were badly set, being over-framed in gold. It was not enough, as in France, to possess one costly set. Fashion demanded that a Spanish lady should have eight or ten sets, some of diamonds, others of rubies, emeralds, pearls and turquoises. "The ladies," as we learn from the Countess Danois, "wear at the top of their stays a broad knot of diamonds, from whence there hangs a chain of pearls, or ten or twelve knots of diamonds, which they fasten at the other end to their sides. They never wear any necklace, but they wear bracelets, rings, and pendants, the latter of which are longer than a person's hand and so heavy that I have wondered how they could carry them without tearing out the lobes of their ears, to which they add whatever they think pretty. I have seen some have large watches hanging there, others padlocks of precious stones, and even your fine-wrought English keys and little bells. They also carry upon their sleeves, their shoulders, and all about their clothes, Agnus Deis and small images. They have their heads stuck full of bodkins, some made of diamonds in the shape of a fly, and others like butterflies, whose colors are distinguished by various stones."—*All the Year Round*.

The "Setting" of Scape Wheels.

IT IS well known that a large scape wheel will set easier than a small one, since more power is required to propel a large wheel than a small one; and in case of an anchor movement, the pallets are set farther from the center of the wheel; mechanics teach that the farther any part is from a given center the more force it will require to move a given weight. We may express it in different words and say that a less pressure will stop a wheel, when it is large, simply because the contact is further from the center. This can easily be demonstrated by placing one's finger against any wheel in the train of a clock or at the tip of scape wheel teeth, when it will be found that the least touch will cause a stoppage. Should we try to hold the pinion, however, we will find that it requires much more pressure. It will, perhaps, be useful to give the relative proportions of this pressure in proportion to the size of wheels and pinions. It will assist in understanding the subject. Let us suppose that we have a wheel three inches in diameter, and on the same axis we attach another wheel one inch in diameter, place a piece of cord round the largest diameter and hang a 1-pound weight on the cord; now wind another cord, the contrary way on the small diameter, and it will be found that it requires a 3-pound weight to hold the other in equilibrium; hence, we see that if one wheel is three times larger than another, it will of necessity require three times more pressure before it can acquire its proper propelling force. Of course, we are aware that the scape wheels of watches do not vary

as much as this, but we simply make use of this illustration to be more readily understood.

Now, when we consider these proportions from the barrel wheel to escape wheel, we can easily understand what a vast difference a slight variation in the size of the scape wheel will make in its propelling force, and this is the reason why we frequently see such strong mainsprings used in some of the inferior grade watches. Were the makers to study well the relative proportions of wheels and pinions, it is certain that they would not employ such strong springs.

After this short digression, let us return to the subject. We must remember that a wheel, if too small, is also very detrimental, since, as it were, it seems too quick for the other parts of the escapement, and being so much under control of the other wheels, it is rather obstinate, and not so willing to make its retrograde motion at the proper time. Of course, when the balance revolves so as to unlock the pallet, the wheel is forced to make this backward motion, but since the pressure is much stronger in a small wheel, when it is extra small, it must lock very hard, and it therefore is very liable to make a bad action, the same as would be produced by a deep depthing. I think I will be understood what I mean by saying that the wheel is too quick, for, with such a pressure it drops into the pallet jewel sooner than it would otherwise, and it is therefore really in advance of the lever and balance. Under these circumstances it is very liable to cut the pallet jewels or get its teeth exceedingly worn. A short time ago I had an escapement of this description under repairs; it had a very broad escape wheel, and the pallet jewels were very round, so that only a small portion came in contact with the wheel, which was perfectly flat, so that the jewels caught each tooth exactly in the center. The watch had only been going about eighteen months, but the pallets had "pitted" the wheel, owing to the excessive force, that all the front parts of the teeth were quite worn out of position.

This will also occasionally happen when a particle of oilstone dust or any similar substance gets on the wheel teeth or pallets. When the wheel has sufficient metal, this can be remedied by carefully filing the front part of the teeth until the "pits" are taken out; but it requires care, as the file must be held exactly in the same position with the angle of the teeth. If this is not observed, the wheel will most probably be ruined, since no good action can be expected of a watch when the angle of its scape wheel teeth has been disarranged.

Japanese Division of Time and Clocks.

LONG BEFORE Japan was opened to foreigners, did the Japanese possess eminent astronomical knowledge and a Zodiac of their own.

Their year began with our 1st of February, and had 12 months. The day was divided in different manners; the military counted, like our sailors, by "watches;" the priests by "divisions," which were marked by the striking of very large bells suspended in their high temples, a custom which is still in vogue, and, finally, the lay element, the population, reckoned by "hours."

They began the day, which was divided into 12 hours, at sunrise, and ended it after sunset. Since the length of the day is a constantly varying one, each month was, for simplification, calculated into a mean length, and this length of day established for the whole month; the Japanese evinced a high degree of science by these calculations.

Their clocks were of two kinds: the so-called "long clock," with hand fastened to the descending weight, and marking time upon an upright dial, and the "round clock," with movable dial and fixed hand, or fixed dial and movable hand.

To regulate the division of hours for the varying length of the different months, many very ingenious contrivances and constructions were used. The matter was comparatively easy with the long

clock. Six dials, shortened according to the falling height of the weight or hand, were each divided into two parts, corresponding to the length of day and night; each of these parts into twelve subdivisions, the hours. Only six such dials were necessary, since, by reversion, a dial used for a summer month could be used for the opposite winter month. At the beginning of every month, the corresponding dial was inserted under the hand connected with the falling weight, and replaced by the next following at the end.

The greatest length of day was 15 and the shortest 9 of our hours, and owing to the contracted space of the falling weight, it had to be wound every morning. To use the clock during night time, the dial was reversed, and the weight wound up.

It is singular that the Japanese, in spite of their clock furnished with ratchet wheel, pendulum, and weights, did not employ the spring as a motive power, but simply used it for striking on clock bells.

The round clocks were provided with weights slideable upon levers, for retarding or accelerating motion, to correspond to the different lengths of days. It is said that these constructions were very excellent, and very correctly going clocks were produced therewith.

Crocus for Polishing Steel.

[By HERMAN BUSH, Hull.]

THE COMMERCIAL crocus does not all times possess the properties necessary for polishing the different metals, and it is advisable, therefore, for the consumer to manufacture it himself, and the manipulations to effect this are easy. Take pure and the clearest obtainable sulphate of iron (iron vitriol, green vitriol, copperas), heat it in an iron pan up to fusion, and permit to remain over the fire, while constantly stirring it with an iron spatula, until it is thoroughly dry, and drops into a pale yellow powder. This is then triturated in a mortar and sifted, placed in a new crucible and left in the fire of a smelting furnace or calcined until no more vapors are evolved. After cooling, the powder appears as a handsome red material, which represents the crocus for the use of gold and silversmiths, etc. The crocus is found in several color gradations, from pale red to brown red, blue and violet. The cause of the diversity of its colors is due to the different degrees of heat made use of in its manufacture; the darkness of the color increases with the degree of heat, and the hardness of the crocus also increases thereby, for which reason a pale red (rouge) is used for gold and silver, while violet is employed for polishing steel, and known under the name of "steel red." Each one of the different kinds of crocus, in order to obtain a favorable result, must be ground as fine as possible, and then washed in water. Three clean glasses are used for the purpose, one of which is filled with water, and a quantity of the crocus is well stirred in with a wooden stick, and left to stand for about one-half minute the fluid is then carefully decanted from the sediment gathered in the glass into the second; after it has stood in this for about two minutes the fluid is again poured into the third glass, and left in it for several hours, to permit the complete settling of the powder. The sediment of the first glass is useless; that of the second is a crocus of an inferior quality, while that of the third is crocus of the best grade. It simply requires to dry slowly to be fit for use. It is also advisable to moisten the dried powder with alcohol, and in some iron vessel to ignite it, whereby the last traces of fat contained in it are destroyed.

The Invention of the Thermometer.

THE FIRST incentive for the invention of the thermometer was given by Cornelius Drebbel, of Alkmar, in the beginning of the 17th century. He took a glass balloon, drew it out into a long tube, heated it and dipped the open end of the tube into a vessel filled with alcohol. According as the sides cooled, and the enclosed air became denser, the fluid rose in the tube. This experiment of

Drebbel dates back to 1603. His apparatus became universally known, especially in Italy, although the instruments could only be provided with arbitrary scales, no fixed unalterable points being known between which a scale could be graduated. At least one such a point was after a while found by the speculative members of the Accademie del Cimenti, and it is highly probable that Galileo suggested it. A small bulb, attached to a narrow glass tube, was partly filled with alcohol, the tube opening was then closed, the bulb inserted in a vessel with snow or ice, and the point to which the alcohol sank was noted. This was at least one point determined, while a second one was still wanting, until discovered by Halley, in 1693, who found that mercury as well as alcohol always rose to the same height in the thermometer tube, when dipped into boiling water. This made it possible to graduate all thermometers alike, but another 40 years elapsed before a regular system was introduced. Fahrenheit, of Dantzic, employed mercury for filling the tubes, established the melting point of ice as the 32d degree, and divided the space between the latter and the boiling point of water into 180 degrees. The zero point of his scale corresponded to the coldest weather which occurred in Dantzic in the winter of 1709. Réaumur divided it into 80 equal parts. Celsius preferred the decimal division, and introduced the centigrade scale. These three scales are the most used in civilized countries. England and France adhere to Fahrenheit's, France uses exclusively that of Celsius, while Germany gives the preference to Réaumur's scale.

The Fahrenheit scale is apparently the most senseless of the three, still it offers two advantages not possessed by any other scale, first, by its minute division, it being necessary with the others, by close observations, to use the fractional parts, since their scales are wider. The second advantage is that it is unnecessary in our moderate climate to affix plus or minus, as the cold does not essentially fall below 0 F.

Colored Films on Metals.

ACCORDING to the prevailing fashion, the small metallic articles used for ladies' ornaments, such as buttons, buckles, clasps, etc., have different colored films produced on them by various methods. (Some of these are known as "oxidized silver.")

Rainbow colors are produced on brass buttons by stringing them on a copper wire by the eyes, and dipping them in a bath of plumbate of soda, freshly prepared by boiling litharge in caustic soda and pouring it into a porcelain dish. A linen bag of finely pulverized litharge or hydrated oxide of lead is suspended in the solution, so as to keep up the original strength of the solution. While the buttons are in this solution, they are touched one after the other with a platinum wire connected with the positive pole of a battery until the desired color appears. The galvanic current employed must not be too strong. The colors are more brilliant if they are heated after they have been rinsed and dried.

Colored films are more conveniently produced upon bright brass by different chemicals, by painting with them or by immersion. For example:

Golden yellow.—By dipping in a perfectly neutral solution of acetate of copper.

Dull grayish green.—Repeatedly painting with very dilute solution of chloride of copper.

Purple.—Heating them hot and rubbing over with a tuft of cotton saturated with chloride of antimony.

Golden red.—A paste made of four parts of prepared chalk and one of mosaic gold.

In covering an article with any colored bronze in powder, it is first rubbed with a very little linseed oil, and the bronze dusted evenly over it from a dust bag. It is afterward heated in an iron pan to about 480° Fahr.

In recent times small articles are also roughened by dipping in strong nitric acid, and, after washing and drying, they are coated with a rapidly drying alcohol varnish that has been colored yellow with picric acid, red with fuchsine, purple with methyl violet, or dark blue with an aniline blue. This gives the desired color with a beautiful metallic luster. These latter colors are not very durable, and are used for inferior goods.

Obituary.

LOUIS A. CUPPIA.

We sincerely regret to record the death of Louis A. Cuppia, a gentleman who had numerous warm friends in the jewelry trade. The deceased was a native of Milan, Italy, and came to this country at a very early age. Mr. Cuppia has always been identified with the jewelry business, and at the time of his death was an extensive manufacturer of gold and silver filigree goods in this city. During the latter part of the summer Mr. Cuppia was stricken down with pneumonia, which rapidly developed consumption and a complication of distressing diseases from which recovery was impossible. Death finally released him from his earthly sufferings, and his remains were tenderly laid away in his family vault at Woodlawn. The deceased leaves a wife and two young children, to whom the sympathy of those who knew the husband and father is extended.

ALEXANDER M. HAYS.

Alexander M. Hays, a well known importer of fancy goods, bronzes, etc., died Oct. 14th at his residence in this city after a protracted illness, in the forty-fifth year of his age. Mr. Hays was born in New York, and at 19 became a salesman in a jewelry and fancy goods firm at No. 23 Maiden Lane. He afterward bought out the business, and five years ago he removed to the corner of Sixteenth street and Broadway, Union Square. Last spring he retired from business, though he retained an interest in the house of Camerden & Forster, who became his successors. His health was much broken by a domestic affliction two years ago, and he never recovered entirely. Among those present at the funeral were a number of gentlemen representing the principal jewelry firms of this city. The remains were placed on board a special train and conveyed to Woodlawn Cemetery for interment.

Gilding Watch Parts According to the Swiss Method.

[By OTTO BEHREND in *Deutsche Uhrmacherzeitung*.]

LET US ENTER into the department for gilding watch parts. The workshop of the gilder is always separated from the main building of the watch factory, on account of the injurious acid vapors, which would cause rusting. Its arrangement is as follows:

Under the faucet of the water pipe, which is a veritable blessing in gilding, on account of the great quantity of water used, we see upon a table several wooden tubs, large flat pieces of corkwood and large stiff short-haired brushes, scratch brushes and rubbing irons—all of them being utensils employed in cold silvering, with which the graining is effected.

Well-closed glass bottles with nitric acid stand upon a shelf, also prussiate of potash, cyanide of potash, purified potash (carbonate of potash), cream of tartar and table salt.

Beneath a second table stand two galvanic batteries, the conduit wires of which lead into the baths upon the table. These are contained in porcelain, or well-glazed earthen vessels, provided with covers, and similar to soup dishes. For sake of suspending as many objects as possible, we see a frame, from which radiate many wires, uniting in a common center, and combined in such a manner as to form one whole.

So as not to be misunderstood, we would explain that two batteries are necessary, in order not to interrupt the progress of the work. When, for instance, a quantity of articles have been suspended in bath No. 1, the already gilt parts are taken out of bath No. 2. A third quantity is being ground, cleaned and silvered, and introduced into the just now emptied bath, during which time the articles in bath No. 1 have become gilt.

There is another, a third, battery kept in reserve, to be used in case one of the former should get into disorder.

When we have next inspected the various glass funnels, porcelain mortars, filtering paper, water stones, grinding coals and the vise, in which a piece of corkwood is always fastened, we have seen the whole internal arrangement of a gilder's workshop.

Our next business will be to observe the manipulations. It is universally known that in order to produce a faultless gilding, it is indispensably necessary to grind the objects perfectly smooth; in the contrary case, every little scratch remains visible after gilding.

After the grinding, the articles are boiled in a strong solution of purified potash or soda, so as to remove every trace of fat or filth adhering to them; they are sometimes merely laid into the solution, next dipped into a mixture of nitric and sulphuric acids and cooking salt, and then plentifully rinsed in clean water.

The pinions, together with the pivots, are previously coated with a substance consisting of shellac, wax and turpentine, and completely covered with it, to prevent the acid from attacking them.

The articles are next fastened with pins upon a large piece of corkwood, and grained, that is, silvered.

For silvering, a fairly stiff paste of silver powder or chloride of silver, cream of tartar, and cooking salt (not much depends upon its exact quantities—moreover we have repeatedly published exact formulas in the Workshop Notes of THE CIRCULAR). Salt is generally the largest component, next cream of tartar, while the silver is the smallest portion.

The silver powder may be purchased in commerce, although the operator can also prepare it himself, if he prefers it. The process is as follows: Pure silver is first rolled into very thin strips, cut into small pellets, and then dissolved in nitric acid. The same purpose is effected if in place of the pure silver, nitrate of silver is employed, which is easily soluble in water (best is rain water).

The silver contained in this solution is precipitated by introducing a sheet of copper, to which the silver clings as powder, or a little salt is added to the solution, whereby the silver precipitates, and forms the chloride of silver.

The latter process is the more simple. After precipitation has taken place completely, the water is decanted, fresh water added, and the procedure is continued (always stirring the entire contents with a glass rod, and waiting until all has deposited) until even the most trifling acid or salt percentage has been eliminated. So as to be secure, the final portions of water must be tasted, and the last one must be without any trace of taste.

With the first-mentioned process, so as to obtain the silver as metallic powder, it is necessary to filter the solution. A glass funnel and the best filtering paper are used for this. The silver adhering to the copper is returned into the vessel with the dissolving fluid, of course, by very carefully using a fine (best is a two-rowed) brush, so that nothing is lost, and after it has settled, all is poured upon the filter, adding from time to time enough of water, until every trace of acid has disappeared. The residue upon the paper is then dried, after which it represents the silvering powder.

When using the chloride of silver, it must be remembered that it can only be employed in a freshly-prepared state, since it decomposes very quickly. It must not be exposed to daylight, as this at once causes decomposition.

The above mentioned three components for silvering, the highly pulverized cooking salt, cream of tartar and chloride of silver, or the silver powder, are next well ground together with water in a porcelain mortar, so as to form a stiff paste. This is applied upon the articles wetted with water and fastened upon the corkwood, and as nearly as possible equally divided with a brush of medium stiffness, which must also be constantly wet. As soon as the silvering adheres to the article, the beginning of which can be noticed by its becoming visible in grey spots, which soon cover the entire surface, another large, very stiff short-haired brush is taken, wetted, and more paste is applied to the constantly wetted articles, which are well belabored, until they assume a uniform neat white appearance.

They are then taken from the corkwood, laid into clean water, and singly scratch-brushed with soap and water. Those parts, however, which are to be grained upon both sides, such as plates and the bridges under the dial, are reversed, fastened upon the corkwood, and grained upon the reverse side.

Some gilders make a decoction, others merely immerse the soap root in rain water, and use it in this condition. The purpose of this procedure is to impart a certain luster to the articles, which is effected in both these ways.

Several, again, use the ordinary brass scratch-brush, while others prefer the glass scratch-brush. The latter are objectionable, however, for the reason that they wear quickly, whereby they are too dear for steady use, and the former time-honored article is preferable therefore.

This must always be unwrapped about $2\frac{1}{2}$ to 3 centimeters ($\frac{3}{4}$ to 1 inch), its wires are separated, and lengthwise rubbed well upon the rubbing iron. The wires divide in the manner of a brush hereby, and become more elastic. This rubbing must be repeated as soon as the ends turn round.

When this, the last procedure, the scratch-brushing is finished, the articles are again rinsed with clean water, and are then ready for gilding, after which they are suspended on the wires of the above mentioned frame, so as not to touch each other.

As far as the wheels are concerned, we would mention that they are not everywhere silvered and grained in the same manner as the plates and badges. Many gilders employ the less troublesome and time-consuming method for current sorts, by the use of which, however, not the handsome, lustrous grain can be produced, as by the above described method. It is less recommendable, therefore.

After the pinions have been well coated with the aforesaid mass of ashes, shellac, wax and oil of turpentine, the wheels are laid for a few minutes in a mixture of 100 parts nitric acid, 50 parts sulphuric acid, 2 parts white vitriol and 1 part cooking salt, for the purpose of producing the mat, and after taking out, repeatedly and copiously rinsed in water.

The longer they are left in this bath, the more intense becomes the mat.

In order to increase the grain, the wheels, *but only for an instant*, are dipped in the following mixture, at once withdrawn, and quickly and copiously rinsed with water. This bath consists of: Equal parts of nitric and sulphuric acids and a very small portion of salt.

Many gilders omit the first bath and only use the latter. A few add lamp-black and decrease by one-half the quantity of sulphuric acid.

It must also be remembered that both mixtures must be prepared at least 12 hours before use, so as to be completely cold. The hereby generated vapors are very injurious, wherefore the work is to be performed in open air.

The amalgamating bath follows next. It consists of 5 kg. (11 pounds) water, 2 grams (1 dwt. 6.86 grains) nitrate of mercury and 5 grains (3 dwts. 5.16 grains) either nitric or sulphuric acid. (Still less nitrate of mercury may be employed.)

This bath is for the purpose of causing a more intimate union, and, in consequence of which, a firmer adhesion of the gilding upon the articles.

The wheels are left in this at most 2 seconds, and they obtain thereby a lustrous silver-white coating, similar to silvering. Should it be specked, however, it is a proof that they were not thoroughly clean.

The wheels, now ready for gilding, are, like the other parts of the movement, stored in a vessel with water, until to be suspended in the gold bath.

I presume it is barely worth mentioning that the articles must, in all these operations for which acids are used, not be touched with steel or iron utensils, nor with bare fingers, but must *only* be handled with brass instruments, or fastened to a brass wire.

Before we proceed, it is well to mention a very objectionable trick made use of by many manufacturers of ordinary goods, in order to save gold, which consists in coppering the parts after silvering and before gilding.

If we consider that with 10 grams (6 dwts. 10.32 grains) of fine gold 100 movements may be gilt nicely in all their parts, in fact, that a greater number is generally gilt with this quantity, it is simply a cause of wonder to hear manufacturers complain of the great consumption of gold.

That such a, as it were, breathed-on film of gilding can by simple handling with perspiring hands, or by a brushing, no matter how careful, be made to disappear, is self-apparent. If, now, the piece has only been silvered, as is and should be done, it becomes white, by the silver making its appearance; if offence has been added to injury, and the piece has been coppered after silvering, it will assume a mat, dirty reddish appearance.

Generally speaking, articles treated in this manner will never have the brilliant, fiery appearance as those gilt directly upon silver.

We now come to the preparation of the chloride of gold and the gold baths.

The fine gold to be employed, in case it cannot be obtained in the beaten condition (as gold foil in books), must be rolled as thin as can be done, and be repeatedly glow-heated during the process, so as to remove all the adhering impurities. It is then to be cut into small pellets, which are bent thus that they do not lay flat upon each other, whereby the process would become very much retarded. Since the pieces are often seized with not over clean tongs, a final glow-heating is necessary.

Thus prepared, they are put into a small retort or porcelain dish, and *aqua regia* (nitro-muriatic acid), composed of 1 part nitric and 2 or 3 parts muriatic acid, according to their degree of strength, is poured over them.

It is not exactly necessary to heat the glass retort or dish during the process of dissolving, which generally progresses sufficiently quick, still the operation may be accelerated thereby.

The dissolving of the gold having been effected completely, the acid is driven off. For this purpose, the vessel with contents are heated above an alcohol lamp, or placed in hot water, or upon hot sand. These latter methods require more time, but are surer, since no chloride can be destroyed thereby, which easily takes place by heating over free flame. The chief condition to be successful is an equal, not unduly strong heat, which is to be continued until no more vapors are evolved, when the solution is of a syrupy condition and has assumed a dark brown color.

The vessel is then removed from the lamp, or water, or sand bath, and left to cool. The residuum appears in circular red-brown crystals, and is the chloride of gold.

If they are dark yellow, or pale red, they were heated too little, but if very dark brown, too much heat has been applied, and, in the language of the gilders, the gold has been burnt. By reason of unduly strong heating, or by drying the solution altogether, the chloride decomposes, and passes into a soluble chloruret, and next into metallic, pulverulent gold. The work has been useless, and must be commenced anew—that is, the gold must be re-dissolved and evaporated.

The ready chloride of gold is now poured over with a little distilled water, in which it dissolves at once, and is then filtered through best white filtering paper laid into a glass funnel. The bottle intended to receive the fluid is to be cleaned in the most careful manner. The filtering is for the purpose of separating any little silver percentage still contained in the gold.

Since chloride of gold decomposes in light, it is to be stored in dark bottles provided with ground-in glass stoppers.

Many gilders use, in place of the chloride, the oxide of gold and ammonia. This is formed in a heavy deposit, if to the gold solution an excess of ammonia (volatile alkali) is added. It is repeatedly washed, or filtered, and used for the bath in a moist condition, since, when dry, it easily explodes. The evaporation of the acid is saved by this process, which, after the precipitate has settled, is decanted.

We will next become acquainted with the preparation of the baths for galvanic gilding, and specify a few recipes of those most commonly used.

The Swiss gilder exclusively uses cold baths of the most simple composition and very delicate condition. They are preferable to the hot and strong baths for the following reasons:

First, the gilding progresses slower, whereby the deposit upon the article becomes more uniform, and therewith also the color;

Second, by the use of the cold bath, the articles may be quietly suspended therein, while, together with the anode, they must, in the hot bath, be constantly moved to and fro, in order to obtain a uniform tone of color. This process, however, cannot be employed in the manufacture of watches, since all the parts of a half-dozen of movements are gilt at once.

(To be Continued.)

Lathes and Lathe Work.

BY THE MODEL WATCHMAKER.

EARLY IN THIS series of papers I gave cuts and description of a lathe altered from the ordinary turns or bow lathe, in which there was a loose pulley fitted to one of the arbors, so as to use it with foot power; since then an apprentice working with the writer, has fitted himself up a going arbor lathe from a good set of turns that I deem well worth the space in this journal to describe, together with the attachments. It does a great range of work, and is extremely accurate; runs with great ease, and if I was called upon to do nothing but pivoting, or new work, such as staffs and pinions, I would take it as quick as any lathe I know, for one reason if no other, and this is it runs so very light. The lathe is mounted on a stand $3\frac{1}{2}$ inches high above the bench, and is driven by a 16-pound foot wheel beneath the bench, and in cost was as follows: Lathe (bought second-handed), a very good set of English turns, or bow lathe, cost \$1.50; foot wheel, \$3.25; brass castings, 60 cents. Of course the fitting up he done himself; but it is so contrived that it is neither difficult or expensive. The stand or support for the lathe is made of two parts, for the convenience of fitting up. They are cast of red brass, and can be made in two ways. If you have the use of a good-sized foot lathe that you can turn the brass pieces in, this is the most expeditious way; if not they can be cast square and filed up. In the illustrations we give we shall assume the parts

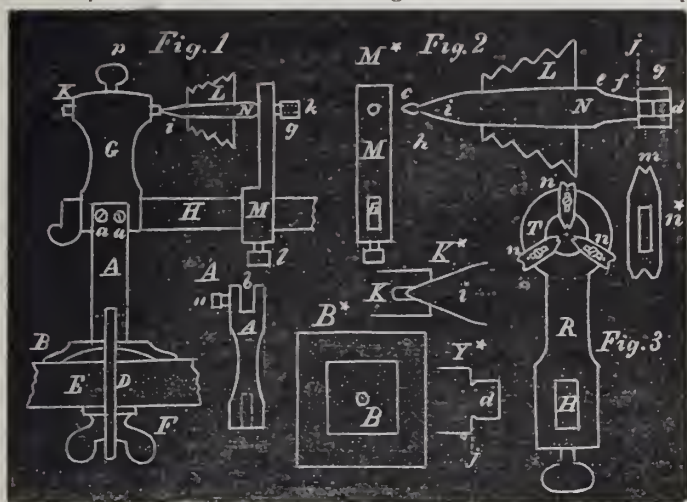

A B are square Fig 1 shows the stand or upright piece for holding the lathe; this should be shaped as shown, and should be when first cast, $\frac{7}{8}$ of an inch square, and concaved, as shown in diagram *A**, both for brightness and elegance. The piece *B* is hollowed out on the lower side to lighten it, and also to enable the screw *D* to hold it flat to the bench. The lower end of *A* is only squared to fit flat on *B*. The idea is the screw *D* is tapped into *A*, as shown, and extends downward through the bench *E* to the thumb nut *F*. It will be seen that, if the thumb nut *F* is drawn up tight, the upright piece *A* will be held rigidly in place. At the top of *A* is a slot shown in diagram *A** at *b*; into this goes the part of the bow lathe that you ordinarily put into the vise; and the set screws *a a* serve to hold it in place. Now comes the live spindle; this is made of a piece of $\frac{3}{8}$ Stubs' steel $1\frac{1}{2}$ inches long, and can be turned up in the lathe you are altering with a drill bow; but it would be better to get the spindle roughed out before trying to turn with the bow. After the spindle is turned into the general form shown in fig. 2, it can be put in the bow lathe and carefully fitted or fashioned into the shape shown. I say put into the bow lathe and finished, for indeed it must be a *very* true live spindle lathe which will turn exactly round. The end at *d* should be drilled and taper countersunk for a cone center to go into; the opposite end at *c* is turned down to near a perfect cone, so that if brken off the part broken will be smaller than the bearing surface of the hollow cone. The idea will be got from an inspection of diagram *K**, where *K* represents a portion (magnified) of one of the centers into which the live spindle runs, as shown at *K*, fig. 1. It will be seen on inspec-

tion of diagram *K**, that if the spindle broken off at *h* runs in a conical countersink in which a hole is drilled larger than the broken cross-section at *h*, that the spindle will run true on the conical part at *i*. The opposite end of the spindle shown at *e f*, is turned to cone bearings, as shown at fig. 2; the cone at *e* being 45° and the part at *f* 6° . On the dotted line *j* is turned a shoulder, and a cylindrical part at *d*, on which a screw is cut. The dotted outline at *g* represents a hollow steel cylinder tapped on the inside to fit the screw at *d*; it will be seen that the screw *d* only extends half way through the piece *g*, consequently chucks can be secured into the hollow screw at *k*, fig. 1. The piece *M* is of brass and made to fit the bar of the lathe *H*; the upright part through which the spindle *N* goes should be about $\frac{3}{16}$ of an inch thick. When finished, and if of cast brass, the pattern need be $\frac{1}{4}$ of an inch in thickness. The hole through the piece *M* should be made to fit the spindle at both the conical bearings shown at *e f*. A little care in fitting up will make all the centers line, and the loose sliding head carrying the other arbor can be used as a back center. A back rest shown at fig. 3, is an indispensable adjunct to such a lathe. Such a back rest was described in one of the early articles of this series, but as many of my readers have not these back numbers we seek to make each article as complete in itself as possible.

This back rest is shaped as shown in fig. 3, and has a socket which fits and slides on the bar *H* like *M*. At the upper end is a ring, shown at *T*. This ring should be about half an inch in diameter on the inside, and have three pieces, shown at *n n n*, fastened to *T*, with screws working in slots. Between the pieces *n* and the heads of the screws should be a little stud washer. One of the pieces *n*, is shown at *n**, of the right size for actual use. It will be seen that one end (at *m*) is smaller—this is for smaller work; while the opposite end is intended for larger jobs, say from $\frac{1}{8}$ up to $\frac{3}{16}$, or even $\frac{1}{4}$ of an inch. Such a back rest will point up the pivots of a lever clock to perfection, as will be described hereafter. To make the piece *g*, a piece of the same steel as is used for the spindle *N* is cut $\frac{1}{2}$ an inch long, and drilled and tapped to fit the screw on the spindle *N* at *d*, and it will be seen that the part on which the screw *d* is to be cut is smaller on the line *j*, and also the shoulder on this line should be undercut. The screw on *d* should run easily into the hollow screw in *g*. After the spindle *N* is made and the slide *M* is all fitted, so as to afford a complete bearing for the forward end of the spindle *N*. It will be seen that the idea is that the spindle *N* will go through the piece *M*, and if the cone bearings are fitted to match on *e f*, if we push the arbor *K* in the head *G* forward, all the lost motion must be taken up, when we fasten it by the nut screw *r*. Now, if the hollow screw *g* is screwed on *d*, we have a live spindle lathe with a hollow screw at *k*, into which we can insert any quantity of screw chucks. But to properly fit *g* and *d* together, let the piece *g* run on *d* so as to strike the shoulder on the line *j*; do not force it, only let it rest against the shoulder strong enough to turn off *g* on the line *j*, turning it down to *f*. Now, on removing *g*, the little ring corresponding in size to *f*, can be filed off flat. This process may have to be repeated once or twice before the shoulder of the spindle *N* and the inner face of *g* comes full flat together. As soon as they do, however, the outer end of *g* is to be turned off true and flat. It is well to harden *g*, reducing it to a good spring temper. A piece of good hard wood—boxwood or *lignum-vitæ*—will make the pulley *L*. The lathe is set up on the bench about 5 inches back, and the band from the driving or foot wheel below the bench comes directly to the pulley *L*, without any countershaft. Although a small countershaft is used to work a wig-wag for polishing, but the supplementary arbor is worked from a band running from the pulley *L*. This matter will be taken up as the attachments are described. The writer does not think that this style of lathe will ever supersede a first class American with all the attachments which are now offered by the many makers; but he does believe and knows that excellent work can be done with one, and that many an apprentice can make a lathe of this kind help earn the money to buy a first class American lathe. The attachments which can be adapted to such a lathe are almost unlimited. But foremost are the various wax chucks, both of the hollow cone form and the flat faced; to these can be added split grasping chucks. These will be described in a subsequent article.

Foreign Gossip.

SWISS WATCH TRADE.—The watch trade in Switzerland employs more hands than any other industry in that country. According to the most recent statistics, the number employed in the manufacture of watches is 40,000.

CALCUTTA EXHIBITION.—Our exchanges all concur in thinking that the Calcutta exhibition bids fair to be a great success. Every inch of space has been taken, and applications from firms who are desirous to exhibit keep pouring in daily, and arrangements are being made for the extension of the annexes. We sincerely hope that the United States manufacturer of all lines of goods will participate.

NICKEL CRUCIBLES.—M. Mermet, in the *Chronique Industrielle*, recommends the use of nickel crucibles, in place of silver ones, for the use of chemists and others. They are slightly attacked, it is true, by melted potash, but silver is liable to the same objection. Their first cost is far below that of silver ones, and, beside this, they have the great advantage of melting at a higher temperature. It often happens that inexperienced chemists melt their silver crucibles in heating them over a gas lamp; this accident need not be anticipated with nickel crucibles.

UNIFORM MERIDIAN OF TIME.—At an early meeting this year of the Paris Académie des Science, the French Minister of Public Instruction asked the opinion of that body as to the reply to be made to the proposal of the American Government for an international conference with a view to the adoption of a uniform meridian and a universal time. The Commission appointed to consider the matter has expressed an opinion favorable to the conference, and has requested the minister to appoint the members to represent France at the Washington Conference.

DISCOVERY OF GOLD IN THE URAL.—A Russian exchange, the name of which, if our readers will permit us 24 hours' time, we will write down for their philological study, is *Jekaterinoslav Nedelja* (there, that's all of it), informs us that important discoveries of gold have lately been made in the Uspenskij portion of the Ural Range, which are said to be very rich. Twenty-two nuggets were found on the first day, four of which together weighed more than a Russian pound, the largest one weighing as much as 1 pound 2½ ounces. The most remarkable feature of this discovery, however, is not alone the gold, but also its peculiar shape, since it occurs in a state of crystallization.

ARCHIMEDES ROBBED OF HIS HONORS.—According to later discoveries, says the *Allg. Journ. d'Uhrm.* (which we quote as our authority, since we do not desire the faintest credit even of trying to wrest the long-worn laurel from the brow of Mr. Archimedes), the Hindoos had formed an expression long before him, which gives the ratio of diameter to circumference as 1,250 to 3,927, and which only varies from the most correct ratio by 0.000074. This was only superseded in the 17th century by the ratio (113:355), given by Huelius Mota. Apart from this, the Hindoos possess a great number of progressions used in analytical geometry expressed, and the applications of which are shown in Sanscrit verses.

THE DIAMOND NOT A CARBON.—The *Journal de Pharmacie et de Chimie* says that an important discovery has been made by M. Berthelot, the celebrated French chemist. From his researches he is led to suspect that the true element carbon is unknown, and the diamond and graphite are substances of a different order. Elementary carbon ought to be gaseous at the ordinary temperature, and the various kinds of carbon which occur in nature are in reality diverse combinations of the true element carbon included under one general formula. Spectrum analysis is thought to confirm this view; and it is supposed that the second spectrum seen in a Geissler tube belongs to gaseous carbon. This spectrum, which has been recognized along with that of hydrogen in the light of the tails of comets, indicates a carbide, probably acetylene.

WATCH INDUSTRY OF BESANCON.—The annual report of the Besançon Chamber of Commerce states that the watch and clock industry of France is on the increase. Over 500,000 watches were manufactured in said town last year—an increase of 50,000 over 1881. The proportion of gold to silver cases is at the ratio of 1:2. Taking the average sales' price of a gold watch at 60 francs, and of a silver one at 20 francs, we would obtain a grand total of 18,000,000 francs. The importation of watches into Besançon is diminishing yearly. In 1881, 32,056 gold and 60,554 silver watches were obtained from other places—chiefly from Switzerland—while last year this number had decreased to 28,218 and 48,704 respectively. The total number of timepieces manufactured in France, in 1882, was 568,722, of which 86 per cent. are credited to Besançon.

THE ORIGIN OF AMBER.—Messrs. Goeppert and Menge lately made some very interesting researches on the flora of the amber-bearing formations of East Prussia. In ancient times there must have been in this part of Europe a group of conifers composing specimens from almost all parts of the world. Among the splendid specimens of the California coniferæ were the red wood, the sugar pine, and the Douglas spruce; and of the examples of the Eastern States were the bald cypress, red cedar, thya, and the *pinus regida*, etc. It appears that the deposits of amber, for which the Baltic is noted, are the product of generations of these resin-bearing trees. The richest deposits lie along a strip of coast between Memel and Dantzic, although the real home of amber has been supposed to lie in the bed of the Baltic between Bornholm and the main-land. It rests upon cretaceous rocks, and consists chiefly of their *débris*, forming a popular mixture known as blue earth, which appears to exist throughout the province of Samland at a depth of from 80 to 100 feet, and to contain an almost inexhaustible supply of amber. Immense quantities are washed out to sea from the coast, or brought down by creeks, and cast up again during storms or in certain winds. The actual yield by quarrying is from 200,000 to 300,000 pounds a year, or five times the quantity estimated to be cast up by the waves on the strip of coast above mentioned.

SCHLIEMANN'S RESEARCHES.—The skill in beating out and inlaying gold and other metals, to which Homer so often alludes, is attested by the remains found in the tombs at Mycenæ, of which, perhaps, the most Homeric are the designs on the scabbards of swords, which, at the time when Dr. Schliemann's book appeared, were too much incrustated with rust to be made out, but which have been recently engraved and described by Mr. Koumanoudes. The subjects represented on these scabbards are a lion hunt, a lion attacking a herd of deer, winged monsters, fish and plants. The manes of the lions are of red gold, their bodies are of paler gold, probably electrum. So with the flowers—the stalks, leaves, and branches are of gold, the calyxes of electrum. The same distinction of color is observed between the sea and the fish swimming in it, and also in representing the birds—in which the color of the blood flowing from their wounds is discriminated from the color of their feathers. Further variety is obtained by the use of enamel in portions of the background. In the description of the ploughing, on the shield of Achilles, the poet says that the furrow behind the ploughman was black, as ploughed land is, although being of gold. Probably to produce a change of color a dark enamel, such as that found in the scabbards, was combined in the gold. Homer, therefore, so far from inventing the shield of Achilles out of his imagination, as was formerly urged, derived many details, both of subject and technical execution, from works of art which he had actually seen, and which inspired him with the conception of what a work by the god Hephæstos himself might have been. So, again, in regard to the choice of subjects on these scabbards, and throughout the Mycenæan antiquities, they prove that when Hesiod describes the crown of Pandora as ornamented with "all manner of creatures, such as the sea and the land breed," he borrowed these ornaments from the art of his own time.

Workshop Notes.

ALABASTER CEMENT.—Melt alum and dip the fracture faces into it; then put them together as quickly as possible. Remove the exuding mass with a knife.

CLEANING GILT FRAMES.—Gilt frames may be cleaned by applying heated alcohol, with a sponge, until all stains are effaced. The alcohol is then allowed to dry off gradually; under no circumstances rub with a cloth.

EXCELLENT CEMENT.—A cement for fastening glass upon wood is prepared by dissolving 1 part caoutchouc in 64 parts chloroform, to which 16 parts mastic have been added. Let the mixture stand until dissolved. It is then applied with a brush.

KNIFE SUSPENSION.—If a very exact rate is expected from a knife suspension of the pendulum, it stands to reason that neither at the polished edge nor in the pan the least rust must be visible, and the only way to prevent it is by slightly oiling the parts. This is especially true of steeple clocks, since they are very much exposed to the action of the atmosphere.

SMOOTHING OIL STONES.—Oil stones are apt to wear hollow, and it is necessary to smooth them. For this purpose take coarse emery and water upon a slate or marble slab, and with a circular motion grind the oil stone. Another very good way is to nail a piece of coarse emery paper upon a board, and treat it in the aforesaid manner. Paper is best, because the grains of emery remain stationary, while, when loose upon the slab, they roll round, and therefore are less effective.

NEW METHOD FOR ANNEALING.—In the oil bath, in which the annealing of the tempered utensils is to be performed, lay a metallic ball of about the size of a pea and consisting of an alloy of 2 parts lead and 1 part tin. This alloy melts at 232° C., and therefore indicates the correct time when the small tools are to be taken out of the bath. Alloys of 3 parts lead and 1 part tin, and 4 parts lead and 1 part tin, melt at 259° or 260° C., at which temperature the utensils become softer.

RAPIDLY SILVER PLATING.—Dr. Burger recommends the following for rapidly silver plating: Prepare a powder of 3 parts of chloride of silver, 20 parts carefully pulverized cream of tartar, and 15 parts pulverized cooking salt; mix it into a thin paste with water, and rub it upon the well cleaned metallic surface with blotting paper. After you are certain that all parts of the article have been touched alike, rub it with very fine chalk powder or dust upon wadding or other soft cloth, wash with clean water and dry with a cloth.

BROWN COLOR UPON IRON OR STEEL.—To produce a brown color upon iron or steel, dissolve 2 parts crystallized chloride of iron, 2 parts chloride of antimonium, and 1 part gallic acid, in 4 parts water, and apply this fluid upon the article with a sponge or cloth, and let it dry in air. The treatment is to be repeated according to the depth of tone desired. The article is next washed off with water and dried, and finally rubbed in with linseed oil. The metal obtains a brown tone in this manner, which resists the influence of the air. The antimonium chloride must be as little acid as possible.

BRASS FOR WATCHES.—Brass intended for watch plates, wheels, etc., must be brought to its highest degree of hardness by equal hammering. French watchmakers use for their watches the brass from old kettles—that is, brass which has for a long time been exposed to different temperatures. It is by them considered unsurpassable. When to be used for watch movements it is hammered until it begins to scale off, when it is supposed that the greatest degree of hardness has been produced. The watchmaker who has heretofore performed the work of hard hammering, knows by experience when the greatest degree of hardness has been obtained, and he need not wait for the scaling.

MINERAL OIL FOR STEEPLE CLOCKS.—Well purified mineral oil is excellent for steeple clocks. For 200 parts ordinary heavy tar oil take 4 parts chloride of lime, and stir it together well with the oil in a glass vessel. Next add 6 parts ordinary hydrochloric acid and stir diligently for about one quarter of an hour. After the mixture has been left to stand for about 5 or 6 hours in complete rest, decant the oil which has collected on top of the watery fluid, wash it several times with clean water, and again treat it with 10 parts soda lye, whereby the oil loses the last traces of impurities. It is then carefully decanted and preserved. I would finally add that the mixture must only be stirred with a porcelain or glass rod (say an old barometer tube).

HARDENING AND ANNEALING SPRINGS.—In order to give push and fly springs a good temper, which they are to retain without being inclined to break easily, I use the following method: The ready spring is first heated and well rubbed with soap in its hot state. I next heat it to a cherry-red (not a white heat), and temper it in petroleum, which does not ignite from the heated steel. The black crust formed on the spring is easily brushed off, and need not be ground off, as is the case with other methods of tempering. The spring is then annealed to a light blue upon the annealing plate of, say, a broad clock spring, and at once rubbed in with tallow, after which it is left to slowly cool upon the annealing plate. A spring treated in this fashion will render good services and be durable.

OVER-ACTIVE COMPENSATION.—*Question:* How can I correct the defect of an otherwise well going anchor watch, with compensated balance, if the compensation is too active? The watch goes faster in warm weather than in cold. *Answer.*—The screws must be set farther back toward the balance arms. Supposing, however, that the removal of the screws be not possible, then the weight of the screws is to be lessened, in order to affect compensation in this manner. The regulating anew of the movement is necessary in this case, since it will now advance in mean temperature. This can be effected either by means of the balance spring or by the increase of weight of the two screws opposite the balance arms. When any correction whatever is made to the screws, carefully re-establish the equipoise of the balance.

A BROWN BRONCING OF BRASS.—Dip the thoroughly cleaned and polished brass article for one-half a minute into a cold solution of 10 grams hypomanganate of potash, 50 gr. sulphate of iron, 5 gr. hydrochloric acid in 1 liter of water, rinse it off well and dry in fine, soft sawdust. If the color has become too dark, or if a more reddish-brown color is desired, dip the article, as soon as it is taken out of the above described fluid, for about a minute into a solution, heated to about 60° C., consisting of 10 gr. chromic acid, 10 gr. ch'oric acid, 10 gr. hypomanganate of potash, and 50 gr. sulphate of copper, in 1 liter of water, and treat it as described above. By the sole use of the second fluid a lighter, darker yellow, or reddish-brown color is obtained. The article may afterward be heated in a drying furnace, whereby it is said it increases in intensity of color.

INGOLD FRAISES.—I have worked for years with the ingold fraises and will say that they are better suited for the manufacture than the repair of watches, in order to give the already rounded tooth the highest attainable perfection of form. The cutter cannot be dispensed with, since they only attack the rounding not the flank of the tooth. The latter only happens if the fraise employed does not suit to the tothing of the wheel, but is coarser, in consequence of which a shoulder is produced at the tooth flank. Be it understood, therefore, that the wheel cannot be made thinner with them, although the wheel may be made a trifle smaller; when the teeth are cut sufficiently deep it is well to turn the wheel down a little. When using the fraise, let it at first attack very moderately, and gradually set the depthing tool narrower until the tooth is thoroughly pointed. A large assortment of them is necessary, in order to be well provided for all repairs, and yet it has happened to me repeatedly, with a set of 84 pieces, at a price of 250 francs, that for fourth wheels of 19-line watches I had no suitable fraise.

Trade Gossip.

The sale of the Spencer Optical Manufacturing Co.'s new celluloid spectacles and eye-glasses is unprecedented.

Giles, Bro. & Co., of Chicago, have recently added a diamond cutting and polishing department to their establishment.

F. S. Dangerfield, of Auburn, N. Y., has introduced a very useful and novel match safe that many jewelers can handle to advantage.

The patent grain initial ring introduced by Freund & Oppenheimer is a neat and taking design and rapidly growing in public favor.

The business of L. A. Cuppia, deceased, will be conducted by C. Cuppia, executor and trustee for the estate, and under the late L. A. Cuppia's name.

W. E. White & Co. have, in addition to their superb line of band bracelets, just brought out a new chain bracelet that is attracting considerable attention.

The mortal remains of Marcus Kronberg, at one time a prominent jobbing jeweler in Chicago, has been cremated in accordance with his dying request.

S. Marks, of the firm of A. Marks & Bro., of Lawrence, Kansas, was in the city recently purchasing goods, and displayed excellent judgment in his selections.

The ninth annual banquet of the New York Jewelers' Association will be held at Delmonico's on the evening of the 8th, and promises to be a very brilliant affair.

A. S. Herzog & Co. have purchased the entire stock of H. J. King & Co.'s rings, consisting of a hundred different designs, which they offer to the trade at a bargain.

The Executive Committee of the Jewelers' Club are negotiating with various celebrities with a view to giving a grand concert, for the benefit of the Club, early in January.

Wheeler Bros. have given up their store at Hallowell, and have established themselves in the jewelry business at Augusta, Me., under the firm name of Wheeler & Lord.

Walter Jones, with Messrs. Heller & Bardel, has just patented a saw-frame possessing many substantial advantages that will doubtless be appreciated by practical workmen.

The greatest pawnbroker's shop in the world is the Mont de Piete, in Paris. It charges only one and a quarter per cent. a month, and it does a business of over 30,000,000 francs a year.

The crockery trade and those tea stores that give presents of glassware and crockery with purchases of tea are glowering at each other, and pretty soon they will be throwing things.

The firm of Wheeler Bros., formerly of Hallowell and Winthrop, Me., has been dissolved by mutual consent. The business at Winthrop will hereafter be conducted by A. E. Wheeler.

The last observations indicate that we are distant from the sun about 92,700,000 miles. These are the figures obtained as near as may be from the observations of the last Venus transits.

The Toronto *Globe* offers a calamity, which they call a watch, to every subscriber of that paper, and the pickpockets of Canada say that if this thing continues their business won't be worth a cent.

S. F. Myers & Co.'s horological novelty is attracting considerable attention. It is a 19 line nickel open face watch with an alarm attachment and operates on the principle of a regular alarm clock.

The alleged editor of the *British Jeweler and Metal Worker* is making a brilliant record for himself by stealing every article from the columns of THE JEWELERS' CIRCULAR he can lay his shears on.

Among articles of new fancy jewelry are buckles of Rhine pebbles. Many old-fashioned brooches and miniatures are used for belt buckles. Long pendants are mounted in pins and used to fasten lace jabots.

Simpson, Hall, Miller & Co. have just completed an extensive addition to their factories at Wallingford, Ct. The new wing, which is of brick, just completed, is 120 feet long, 40 feet wide, and four stories high.

E. M. Howes, of Clinton, Iowa, has been to town in search of novelties for the fall and holiday trade, and the good people of that enterprising town will, in consequence, be treated to a rich display of artistic goods.

The Custom House examiner at the Post Office recently seized a parcel containing 132 diamonds, 200 sapphires and 85 rubies, valued at \$10,000. The parcel arrived in the foreign mail and was addressed to a firm in this city.

A. Bernhard & Co. will shortly issue a very useful catalogue of designs, showing numerous illustrations of diamond settings especially desirable for manufacturers, to whom a copy of the work will be forwarded upon application.

A Custom House inspector recently went to the Post Office and took possession of a package containing moonstones and a general assortment of gems. The goods were taken to the seizure room of the Custom House for further examination.

Sleeve buttons, which have been but little worn of late by ladies, owing to the peculiar style of dress sleeve in vogue, are revived and promise to be worn during the winter season. The link buttons are the fashionable style for both ladies and gentlemen.

Two remarkable and curious walking sticks are in the possession of Robert Tale, of Norwich, Chenango county, N. Y. The walking sticks contain 1,400 separate pieces ingeniously wrought. The cane contains 2,000 pieces, many of them relics from historical spots.

Ellison & Vester are making an attractive line of woven chain bracelets in rolled plate. These goods are neat and showy, and, by a patented process, the edges are made of the same quality plate as the body of the bracelet, so as to impart a uniform wearing surface.

The enterprising firm of Wheeler, Parsons & Hayes still maintains that character that has made the house famous, and in its transactions keeps fully abreast of the progress of the age. They carry a very complete and well assorted stock of all the latest novelties in their line.

D. L. Safford's Mercantile Agency has been incorporated into a stock company, and will hereafter be known as the Jewelers' Mercantile Agency, Limited. The officers of the Company are D. L. Safford, President; C. H. Swonds, Treasurer; W. H. Bowers, Secretary.

G. C. Booth, with Fowler Bros., was recently presented with a handsome diamond stud by his employers in token of their appreciation of his services. "Cliff" is one of the most popular men on the road. Fowler Bros. are noted for their liberality towards their employees.

So great is the popularity of colored gems, they are in demand for engagement rings. Stones competing with solitaire diamonds for a place in the betrothal ring are the sapphire and the ruby. For the engagement ring any shank may be used that is simple or odd in its construction.

The Derby Silver Company is now comfortably settled in their up-town branch store at No. 3 Union Square. The decorations are, without exception, the most artistic and beautiful that we have ever seen. The Company will continue to occupy its down-town store at No. 25 Maiden Lane.

The furor for fancy stones has greatly increased both the demand and money value of what were formerly termed semi-precious stones. Stones of fine color or brilliancy are desirable at the present time, even though they fail to possess the characteristics that mark, in the mineralogist's estimation, a true gem.

The electric clocks in Paris number 15, and 7 are upon one circuit and 8 upon another. But their working is not quite satisfactory. During the past year they have gone out of order from various causes and lost as much as two seconds from the effect of the vibrations of the streets upon the regulators.

Women are working their way into all branches of industry in Russia. They are now seen in clockmakers' and jewelers' shops, but especially in the workrooms of china painters. The last development is attributed to the influence of the drawing school of the Society for the Encouragement of Artists.

Many of the new bracelets are little more than gold pins connected here and there with a gem. Fancy stones are much employed on bracelets, different colored stones being often set in the same bracelet. The gems are also set at irregular intervals; anything like uniformity of color or setting is avoided.

Rings are still worn by ladies, to some extent, on the little finger, but pendants no longer find a place on them. These rings are set with colored stones, which are often selected according to their language. Sapphires, emeralds and stones of a transparent nature are the sort patronized for gentlemen's finger rings.

A watchmaker named Robert Schmidt, recently received from a wholesale house in Maiden Lane, a number of gold watches to be put in order. It was subsequently discovered that Schmidt had pawned and otherwise disposed of them, and had fled to Cedar Keys, Florida, where he was arrested and brought to this city.

Jeanne Bros. have introduced another unique novelty in settings for diamonds, etc., the crown of which is so constructed that the gem rests surrounded by platinum while the wearing surface on the outside is of gold. The stone in the setting is therefore prevented from borrowing reflected lights, an objection to be found in gold settings.

A little present, in the strictest sense of the phrase, has been lately made to the German Crown Prince and Princess, in the shape of a "fairy tea service." The tea tray has been beaten out of an old Prussian half-penny. The tea pot is made out of a German farthing. The tiny cups are made from coins of different German principalities.

At the State banquet given to the German Emperor in the Palm Garden at Frankfort, the Imperial table was ornamented by a magnificent display of gold plate lent by Baron Rothschild. In the middle was the famous center-piece purchased from the city of Nuremberg, which is valued at £36,000. The whole service is worth over £100,000.

G. W. Washburn, with Messrs. Randel, Baremore & Billings, has just received letters patent for an ingenious ear ring fastening, designed for the better protection of jeweled ear rings; they are easily adjusted in the ear of the wearer, and cannot be accidentally or surreptitiously detached, but are readily removed at the sweet will of the wearer.

The opal is fast losing its reputation as an ill-omened stone and gaining in approbation all the time. Hungarian opals are the sort most highly prized, and are often associated with diamonds. The turquoise is going out of style; only the large specimens attract notice now either from seller or buyer. The tourmaline is a popular stone and it comes in many distinct shades.

C. M. Kinsel, formerly of Wittich & Kinsel, Columbus, Ga., retired from business some two years since with a view of passing the remainder of his days in his native land. But tiring of the monotony of his old home has returned to Columbus to join his former partner, and the two worthy gentlemen are again in business under the old firm name of Wittich & Kinsel.

All precious stones which have any associations with ancient superstitions, mythological or historic interest, are prized. It is quite the fashion, in selecting birthday presents, to choose one of the so-called zodiac stones, each of which is supposed to represent one of the twelve months of the year. There is also a fancy for regarding the language of stones in their selection.

The matrimonial fever is raging violently at the American Watch Co.'s factory, at Waltham, Mass., and quite a number of its fair employees are reported to have succumbed to its contagious influence; many others are seriously affected, but their friends are hopeful of their ultimate recovery. The local jewelers in the meantime are doing a land office business in wedding rings.

The firm of J. T. Scott & Co. have leased the premises No. 4 Maiden Lane, increasing business having crowded them out of their old quarters. The store on the ground floor, which they expect to occupy about February 1st, will be refitted with every convenience necessary for the display of goods and comfort of buyers. Especial accommodations will be provided for their friends, who are cordially invited to make their store a business home during their stay in town.

Broad finger rings are a thing of the past, and in their place have come rings with what are termed among jewelers a "round wire shank," a "half-round ring," and "half-round paper shank." The half-round ring is the form patronized for the wedding ring, which is quite plain in character. Fancy stones are largely employed in finger rings, and there is a decided tendency to blend colors in one setting. The stones are set low and show no gold. The English form of setting is the favored one.

During the last month two jewelry stores were robbed. One was that of F. Ralshoven, of Detroit, the thieves securing \$15,000 worth of goods. The other was that of G. E. Cannon, of Johnstown, N. Y., the loss being \$4,000 in cash and fifty watches. In each instance the thieves forced the safes and got away with the goods successfully. It is evident that several gangs of thieves are working different sections of the country, and the trade should adopt every precaution to prevent their depredations.

Ear rings have regained a high state of popularity, especially solitaires for evening wear. The screw ring is the leading style, and the only other sort fashionable are the short rings. Solitaires of fine color and uniform shape are in active demand for ear rings. The fashion of wearing different colored stones in the same pair of rings, seen occasionally last season, is perhaps a little on the increase.

Leroy W. Fairchild has just issued an illustrated catalogue of new designs in gold pens, charm pencils, match safes, whistles, and a variety of other objects of personal adornment that is really a work of art. The grouping of the illustrations is most graceful, while the typographical appearance of the work is all that could be desired. The catalogue will be forwarded to members of the trade upon application.

An extraordinary pearl has been found at Nichol Bay. It is composed of nine distinct pearls about the size of peas, of a fine luster and firmly bedded together in the form of a perfect cross about an inch and a half long. It is a perfectly unique curiosity and is expected, says the Melbourne *Argus*, to fetch a fabulous price, owing to the extraordinary coincidence of its perfectly representing the symbol of Christianity.

An eastern manufacturer of cheap jewelry recently conceived the idea of decorating neck chains with imitation five-cent coins of the new issue. One of his workmen informed him that there was a penalty against making imitations of United States money, and the jeweler consulted Chief Drummond on the subject. The Chief informed him that he "had certainly had a narrow escape from arrest for counterfeiting," but he would not arrest him providing he would deliver all of the medals and the dies from which they were made, at the Secret Service Office in this city. The jeweler lost no time in complying with the suggestion, and the coins were sent to Washington for destruction.

The lace pin has figured conspicuously in jewelry for ladies' wear the past three or four years. It has proven immensely convenient, and is susceptible of a great variety of ornamentation—reasons sufficient, perhaps, for its continued favor. The round brooch disappeared entirely during the reign of the lace pin, but this season brings it back in fancy patterns. Then, too, there is a pretty fashion in pins adapted from the French and consisting of two scarf pins with a festoon or chain of diamonds or pearls between. Ladies, by the way, have taken of late a fancy for wearing the ordinary scarf pin designed for gentlemen. With all these styles, however, the lace pin continues to attract, in new designs, which are for a large part odd and fanciful. Limoges enamel is much used in its decoration. So are fine gems.

The success of the pearl fishery in the Gulf of Mexico has, during the last six or eight months, been so extraordinary that people are now flocking to the spot just as years ago they flocked to the gold fields of California. A report has been circulated in England that numerous phenomenally large pearls have been found. This, however, is not so. The biggest pearl that has been hitherto discovered in the Gulf of Mexico was fished up in December last, and weighed 75 carats. It was immediately sold for \$14,000, and has since been resold for about twice that sum. The only other pearls of remarkable size that have been obtained are two weighing 40 and 47 karats respectively. But almost every oyster that is brought to the surface contains a pearl of some kind; and it is the comparative certainty of reward—though possibly the reward is not be great—that is attracting so many adventurers to the fisheries.

In our September issue will be found the counterfeit presentment of a fair but frail damsel perched upon the precarious edge of a flop-over button. She is gracefully holding in her outstretched hand a flap-jack turner, while her magnetic blond locks kiss the gentle heifers (zephyrs we should say) as they gracefully float on the soft sighing breeze of a dreamy one light-undershirt-and-no-suspenders evening. We are not disposed to criticize too closely the anatomy of this young lady, but cannot refrain from remarking that such attenuated extremities as presented in the picture, are positively disreputable. We have known Howard for many years, and always regarded him as a man of superb taste and exquisite fancy, but those legs destroy this fond delusion. In the present number our friend presents a picture of the offspring of this misalliance whose paternity will be recognized at a glance. It will be observed that what the maternal relative lacked in pedal extremities is fully compensated for in the limbs of her cherub, who is seen triumphantly sitting upon the top of the world holding in one hand a seven and a half pound American Lever sleeve button, while with the other he is endeavoring to arrange that garment which is deemed indispensable to infancy. Lest these illustrations should be misunderstood, we deem it necessary to furnish this explanation of them.

Terrence McDonald, of Jersey City, obtained a pair of diamond ear rings, valued at \$475, on memorandum, from Otis Anderson, a diamond merchant at No. 6 John street, on January 3, under the representation that he could find a customer for them. He did not return with diamonds or money, nor would he give any satisfactory account of them. Mr. Anderson caused his arrest and indictment, and when the case came to trial McDonald was convicted of grand larceny in the second degree, and awaits sentence. This case is one of interest to the trade, being the first where a conviction has been obtained against a person for embezzling goods trusted to him on memorandum. Other cases have been brought before the courts, but the accused person always found some loop-hole through which he escaped. Assistant District Attorney O'Byrne is entitled to much credit for the manner in which he conducted this case.

In Switzerland as in other countries there are a certain class of unscrupulous manufacturers who, when they see an article of merit achieve a deserved popularity, immediately get up a cheap imitation with intent to deceive. We are continually hearing of depredations on the trade of this nature, and regret that it should be so. It is a fact that of late a great number of cheap, thrashy watches of Swiss manufacture have been sent to this country which are a disgrace to that country and its manufacturers—they are so bad that not even a pickpocket of any self respect would be caught stealing one if he could help it. One of the most recent and flagrant instances is a cheap imitation of a well-known Swiss movement, which closely resembles the original in everything save intrinsic merit. The trade should be on its guard in respect to this deceptive movement, for the retail dealer has his reputation to preserve equally with the manufacturer, and he cannot afford to deceive his customers by selling spurious grades.

"What time was it when you tripped up the old gentleman in Grand Street?" he was asked. "About thirty-seven o'clock, your honor," he replied with a sober face. "About what?" "Thirty-seven o'clock, or thereabouts!" "What sort of a watch do you carry?" "Ordinary one, sir; but I'm a brakeman on the Pennsylvania Railroad. The company talks of adopting the system of measuring the day by twenty-four hours, instead of beginning over again at noon." "So you've put it in practice in advance of your employers?" "That is it, your honor." "But how do you arrive at thirty-seven o'clock?" "That's according to—— When I get home at two in the morning, she calls it fourteen o'clock—and so on. Now, I get off on a spree occasionally, and then she figures the time by hours right along until I come in. Yes, sir; it must have been nigh thirty-seven when I had the accident with this gentleman." The prisoner's funny thought saved his ten dollars. The complainant laughed forgivingly, and the magistrate said: "Go home and regulate yourself by conventional time."—

In many small shops in the Bowery for the sale of jewelry, etc., may be seen the sign, "Pawnbrokers' tickets bought and sold." On inquiry it was found that 10 per cent. of the face of the ticket is generally paid by these dealers, who thus obtain their stock at a low value and make large profits. A watch, for instance, worth \$30 is pawned for \$10—the usual rate. For this the dealer in tickets pays the impecunious seller \$1, and on redeeming the watch pays \$10.50, say—getting a watch which he can sell for \$20 and clear \$9.50 profit. So far so good. But in selling tickets there sometimes occur cases of exceedingly sharp practice. A young man recently, desirous of obtaining a bargain, purchased a ticket of a dealer in the vicinity of Great Jones street for a gold watch pawned for \$7, for which the dealer had paid 70 cents, or 10 per cent., and which he sold to the young man for \$1, saying he had seen the watch and it was all right. Filled with the idea of possessing a good gold watch for the moderate sum of \$8.50 or thereabouts, the purchaser hied him to the pawnbroker's and redeemed the article, paying \$7.60. But to his disgust the watch proved to be entirely worthless as such, a mere worn-out shell of gold, with an old set of brass works rattling about loosely inside, no crystal, and in a generally dilapidated condition. A jeweler offered him \$5 for it as "old gold." He returned to the pawnbroker's and offered it in pledge, when the same man from whom he had just redeemed it for \$7.60 said the most he could lend on it was \$3, and denied ever having seen it, although it had left his hands only half an hour before. On consulting a policeman the purchaser found he had no remedy but to sell the watch for what he could get, and he therefore accepted the offer made him of \$5—being \$3.60 out of pocket, but a gainer of perhaps his money's worth of experience in "Bowery tricks."

There have been more retail dealers in the city recently, making purchases for the fall trade, than ever before. The retail trade is evidently awaking to the importance of visiting New York once or twice a year for the purpose of seeing the styles if for nothing else. Among the most recent dealers we notice Mr. Thomas, of Charleston; James Allan, of Charleston; Mr. Bonstell, of Levison Bros, San Francisco; Mrs. L. Kupfer, Dillon, Montana; Sol Marks, of A. Marks & Bro., Lawrence, Kan.; C. L. Bird, Memphis, Tenn.; W. F. Fisher, Chattanooga, Tenn.; E. O. Zadek, Mobile, Ala.; B. A. Bell, J. H. Bell & J. N. Bell, N. C.; F. A. Robbins, Pittsfield, Mass.; J. F. Harsch, Vincennes, Ind.; J. A. Webb, of Webb & Hall, Janesville, Wis.; Foltz & Frank, Akron, Ohio; J. W. Eddy, Kewanee, Ill.; M. V. B. Elson, Freeport, Ill.; B. O. Hagen, Newton, Kansas; Mr. Chas. Broglie, of Broglie, Spear & Co., Honolulu, Hawaii; Kenneth Melrose, of W. K. Vaaderslice & Co., San Francisco, and numerous others.

The convention of railroad magnates which recently met at Chicago to discuss Mr. Allen's new system of national standard time have adopted that gentleman's ideas, and the new system will take effect Nov. 18th. The Harvard Observatory is fully in accord with this new departure, and promises to furnish telegraphic signals conforming to the minutes and seconds of the proposed standard. Under the new system, instead of running the various systems and divisions of systems by as many local standards of time, the continent is to be divided into five broad belts, running north and south, the time for each of which will be one hour slower than that of the next division to the eastward and one hour faster than that of the next division to the westward. By this plan the minute hand of a traveler's watch will not have to be changed, however far he may have to travel or in whatever direction; but his watch will be just one hour slow when he crosses the imaginary line into the next division to the east, or one hour fast when he crosses the line into the next division to the west. The time now furnished by the Harvard Observatory is the mean solar time for the Boston State-house. The new time will be 15 minutes 44.5 seconds—practically 15¾ minutes—slower, and will be the average time for this division, which includes the New England States, New York and Pennsylvania, and the greater part of Canada. North of Lake Erie the division extends west to Detroit, while south of Lake Erie Pittsburg is practically on the western boundary of this division. Thus in the region north of the lake the standard time will be five hours slow by Greenwich, and south of Lake Erie and west of Pittsburg it will be six hours slow by Greenwich.

"That was an expensive set of jewelry," remarked a reporter of the Boston *Globe* to a resident dealer alluding to a set of diamonds a young lady had just taken with her. "It is the most expensive set we have in the store," was the reply; "but she has only hired them." "Is that a common thing?" asked the newspaper man. "Most certainly. Most of our best customers hire a set of jewelry for an evening, and for a comparatively small price excite the envy and jealousy of their friends. I wonder you have never heard of it before. We take our costliest gems and reset them to please our customers, and then rent them. Of people whom we know we never require any security, but a stranger would, of course, have to deposit the full value of the gems. A funny thing happened in connection with this branch of our business. There was to be a large german, and a young lady, well known in this city, came to make arrangements about a set of diamonds. I was not in the store at the time and knew nothing of the matter, so when I came in I let out the same set to another young belle. In the afternoon No. 1 came in and asked significantly if her diamonds had been cleaned. While she was talking, No. 2 put the same question to me. The situation was very awkward, but I explained the matter and all was finally settled in favor of No. 1, the young ladies pledging each other and me to eternal secrecy. 'I wouldn't have it get out for the world, you know,' explained No. 1. Another branch of our business is to rent silver services. These were very well paid for. Most of the designs are antique, and some of them have figured in many Boston homes as highly-treasured heirlooms. At weddings we frequently furnish large collections of bric-à-brac and other articles to swell the number of 'gifts' and make a fine display. We rarely get much for this, as the jeweler's name is frequently published whenever there is anything particularly beautiful given as a present, and the advertising compensates us."



THE
JEWELERS' CIRCULAR AND HOROLOGICAL REVIEW

The recognized organ of the Trade, and the official representative of the Jewelers' League.

A Monthly Journal devoted to the interests of Watchmakers, Jewelers, Silver-smiths, Electro-plate Manufacturers, and those engaged in the kindred branches of art industry.

SUBSCRIPTION:

To All Parts of the United States and Canada,
\$2.00 Per Annum; Postage paid.

To Great Britain, France, Switzerland, Germany, the West Indies, Mexico, the Republics of South America, and Australia, \$3.00 per annum. Postage paid.

All communications should be addressed to D. H. HOPKINSON, 42 Nassau Street, New York. Advertising rates made known on application.

THE JEWELERS' CIRCULAR AND HOROLOGICAL REVIEW enters upon the Fifteenth year of its publication with the issue of the February number. In accordance with an established custom, all Subscriptions terminating with the present volume, ending January, 1884, will be discontinued if not renewed. We hope to have all our old friends continue with us, and to add many new names to our list of Subscribers. Of late we have received several complaints from Subscribers stating that they do not get their paper regularly; we can only say THE CIRCULAR is forwarded promptly each issue to Subscribers. We hope that our friends will notify us at once if THE CIRCULAR fails to reach them on its monthly mission; on so doing we will forward the missing copies.

Diversified Stocks.

WE CONTINUE to receive many letters from retail dealers commending the articles that have appeared in THE CIRCULAR advising them to introduce other lines of goods in their stocks for the purpose of meeting and counteracting the outside dealers. Those who have tried the experiment report that it has been successful, introducing to them many new customers, who have not only bought of these "outside" goods, but have purchased many articles from their regular stock of jewelry. They find little difficulty in purchasing the goods they want, and some of those who bought a few things experimentally, propose to add many others during the winter. One dealer says: "I did not at first approve of your suggestion, believing that, according to the old adage, the shoemaker should stick to his last, but your articles convinced me that the outsiders had not only got a firm footing in the jewelry trade, but were extending their business, and that manufacturers and jobbers were aiding and abetting them. You also convinced me that the manufacturers and jobbers would continue to do this, because the outsiders buy more liberally and pay

more promptly. So I said to myself, that adage about the shoemaker is all well enough, but by sticking to *my* last I am losing trade. I am a watchmaker, trying to become a merchant, in a small way, by retailing jewelry, and am gradually starving to death; why not enlarge my opportunities as a merchant? I see lots of persons pass my door who want to buy something; if I put what they want before them in an attractive manner, why won't they buy of me? They *do* want something and they *don't* want jewelry—why not offer them stationery? I did so. I obtained a small lot of attractive stationery and displayed it conspicuously in my show window, and, as people passed, I heard such remarks as 'Hello! Jones is making a show; got some new goods; getting enterprising,' etc., and soon they came in, and my sales increased very materially during the first month. I then put in more varieties of goods, and now my store is not only the most attractive in the place, but the best patronized, while my sales of legitimate goods have increased 25 per cent. or more. I believe in a diversified stock." Other letters are of similar import.

A dealer writes to a Western publication taking the other side of the question. He says: "That plan may be all well enough for jewelers who have more money than they can profitably invest in their regular stock; but for the ordinary dealer I think it would add to his trouble rather than lessen it, for he would be obliged to make more accounts with new houses, and in these lines the credit given, if given at all, is shorter, and, as a rule, the jobbers are not half so accommodating as those in the jewelry or silverware line. I say a jeweler must show himself to be a man of honor, worthy of patronage, and competent to do the work entrusted to him in a workmanlike manner, and I am sure the citizens, yes, the merchants of his town, will, as a rule, rather help him to trade than attempt to take it away, as it must be remembered that the regular jeweler has almost every advantage over an outside dealer by being well posted in his business."

This critic has, unconsciously, stumbled on the principal reason why manufacturers and jobbers cater to the outside trade, and that lies in the fact that retail jewelers ask such long credit and are such slow pay. In other lines, "the credit given, if given at all, is shorter." If retail dealers had not asked such long credit, they would not have the outsiders to contend with. These came to the manufacturers and jobbers and offered the same prices, "spot cash," for goods that the retail trade wanted at four months' time, and the temptation was too great to be resisted. But our critic's remark about citizens and merchants helping the dealer to trade is absurd. It is well known that every citizen, as it is his duty to do, will buy where he can buy cheapest. There is no sentiment in business, but if a dry goods man sells boots cheaper than the bootmaker does, the jeweler will buy of the dry goods man every time, other things being equal. If an outsider sells jewelry for a less price than the jeweler does, he will get the trade, and citizens are not going around with tears in their fists and their eyes doubled up, trying to persuade their neighbors to patronize the regular dealer. What merchants will do in the matter is shown by the way so many of them have set up in opposi-

tion to the retail dealer instead of trying to help him. The idea of there being sympathy in trade is all poppy-cock. The motto England has made so famous has been universally adopted by mankind—"buy in the cheapest market and sell in the dearest," and it is a very good rule for retail dealers to follow. They will find a cash market always much cheaper than a credit market, a fact realized by all good merchants.

We have not claimed that a diversified stock was the great cure-all for the evils from which the trade suffers. We recommended it as a means of meeting the competition forced on retail dealers by the outsiders—fighting fire with fire. In many instances the plan has been successful, and we have not heard of a single case where the effect was otherwise. We have reported where outsiders have given up selling jewelry the moment the regular dealer introduced goods that encroached on their specialties. There are many dealers who cannot, for various reasons, introduce outside lines of goods; it would not be good business policy for them to do so, and to such our advice does not apply. But the fact remains that outsiders have built up a strong competition in the retail jewelry business; their patronage is so desirable that manufacturers and jobbers, being human, cannot and will not refuse it. What, then, is the best method of meeting this growing evil? We have suggested as one remedy the introduction by retail dealers of other and attractive lines of goods for the purpose of catching the eye and the dollars of the public. Dealers themselves will devise other methods suitable to their surroundings and their business. Our purpose was accomplished when we called the attention of the trade to the necessity of doing something.

Small Trade Worth Looking After.

AT ONE OF the banquets recently given to Chief Justice Coleridge, of England, in this city, he remarked, substantially, that he was not particularly impressed with the vastness of this country, for he had previously known about how much land lay between the Atlantic and the Pacific; but whether this should be the "great country" we are so fond of boasting about, depended entirely upon the character and quality of the people. Regarding these he had formed a most favorable opinion. Had our honored and honorable visitor extended his journey into the far West, he would have received a more vivid impression as to the progressive spirit of the people. He would there have found that an immense wilderness has recently been reclaimed from its natural condition, and that where, ten years ago, there was but a dreary waste, there is now one of the most fertile regions on the continent, abounding in well cultivated farms, teeming with agricultural products, and swarming with cattle of all kinds. He would have found a region where, but recently, flour was worth \$20 to \$30 a barrel, now exporting millions of bushels of wheat, corn, etc., every year. As this vast region has been developed, there have sprung up in its midst hundreds of flourishing villages and cities, each the center of a large and productive agricultural district, while many of them are enriched by the close proximity of rich mines of various precious metals. Trade and commerce flourish in these pioneer cities to an extent that cannot be fully appreciated except by those who have visited them, many of them being much more progressive in their tendencies than some of the older cities of the East. In some of these, standing where, ten or fifteen years ago, the buffalo and the Indian roamed unmolested, the streets are lighted by the electric light, street cars run from one end to the other, telephones are common, and the places of business display the same kinds of goods that are to be seen in Broadway or Maiden Lane.

In each of these hundreds of new villages or cities there is always to be found retail jewelers in numbers proportionate to the population. They are nearly all watchmakers, good mechanics, hard working, conscientious young business men, who have taken Mr. Greeley's advice and gone West to grow up with the country. They have not,

as a rule, large amounts of surplus capital, but they carry such goods as they can afford, and contrive, in the course of a year, to work off a fair amount. Their patrons are the prosperous miners, farmers and business men in their vicinity, who, having made their money easily, spend it lavishly. These young retail dealers, however, do not receive so great an amount of their patronage as they would if they had a larger variety of goods to show. A great portion of their sales, which are mostly fine goods, have to be specially ordered because they cannot afford to keep them in stock. In this respect they have not had the facilities accorded them by the trade that they are legitimately entitled to. Eastern men are apt to regard these Western cities as "paper towns," and the dealers located in them as men of little weight—sort of peripatetic adventurers, here to-day and likely to be somewhere else to-morrow. This is a very erroneous view to take of the situation. The greatest development this country will see during the next century will come from the region West of the Mississippi River, and the pioneer tradesmen of that section are slowly but surely assuming a degree of importance that Eastern merchants cannot afford to ignore. On the contrary, they should do all in their power to encourage and aid them. There is a vast amount of trade to be secured there, in small amounts, possibly, but, nevertheless, worth good hard money. As it is a fact that some of the best, most enterprising and progressive men of the day are to be found among the business men of these pioneer cities, so it is true, also, that the business men of those places will average as well in capacity and integrity as the same classes in the Eastern States. They are good men to cultivate, to make friends with, to aid and encourage. It would be a good thing for the jewelry trade to extend to these struggling retail dealers in the frontier towns greater facilities for doing business; place more goods at their disposal; send commercial missionaries among them with sample trunks, and see that they are supplied with the latest novelties. When they send orders for goods, do not pass them over as of little account, but fill them promptly and liberally. They have a constituency to cater to that is liberal almost to profligacy, and the retail dealers should be in a position to fill all their wants in the jewelry line. This is a good trade to cater to, even in its present volume, while its future prospects are illimitable. We entreat liberal treatment for the pioneer retail dealers.

Memorandum Victims.

IN OUR issue of last month we alluded to the conviction of Terrence McDonald on a charge of larceny for having disposed of goods that he obtained from Otis Anderson on memorandum and failed to account for. Subsequently the court sentenced McDonald to two and a half years' imprisonment. This conviction has an important bearing upon the trade, especially upon dealers in diamonds, who have been quite extensively victimized by persons calling themselves brokers. These individuals have frequently obtained valuable goods on memorandum under the pretense that they had a customer for them, and, having sold or pawned them, have defied the dealers to prosecute them. Heretofore some flaw has been found in the law by which they have contrived to escape, but now the court holds that, under the new Code, this offence is no longer a simple breach of trust, but is plain, vulgar larceny, to be punished by imprisonment. Dealers can now feel assured that they have some more definite hold on memorandum goods than ever before, while those who avail themselves of the memorandum privileges will understand that they must honestly account for the goods entrusted to them. The fact that the law was undefined on this point, has led dealers at times to refuse memorandum privileges to persons who were really entitled to them, and where to have given them would have been to their own advantage. There are many salesmen, for instance, temporarily unemployed, who are entirely trustworthy, who have opportunities for disposing of diamonds occasionally, and who could do a

good bit of trade if they had the advantages of the memorandum system. So long as the system is recognized at all, these salesmen, possessed of character and integrity, might advantageously be included among those enjoying its privileges. But the line should be closely drawn so as to include only those who are legitimately connected with the trade. Those so-called brokers, whose reputations are somewhat clouded, should no longer be permitted to abuse the memorandum system. They have wormed themselves into a questionable identification with the trade, and are certainly no credit to it, even though they do not positively disgrace it by dishonest acts. Some of the dealers have shown a remarkable degree of recklessness in this matter, and now that the abuse of the memorandum idea has been defined by the courts, they can well afford to be more discriminating. Mr. Anderson is entitled to great credit for having pressed the case against McDonald to a conviction, in the face of many threats made against him and considerable political influence exerted in behalf of the accused. It is a good thing to have it established that the failure to account for goods obtained on memorandum constitutes larceny.

Jewelers' Safes.

DURING the past year an unprecedented number of jewelers' safes have been despoiled by burglars. Scarcely a day passes that the telegraphic dispatches do not contain accounts of one or more robberies of this nature. If the aggregate amount of plunder thus acquired by the thieves could be estimated, it would be found to run well up into the hundreds of thousands of dollars. Months ago we received information that a number of professional burglars had organized into gangs to work the jewelry trade in different sections of the country, and we then put the trade on its guard. Notwithstanding this notice, the robberies of jewelry safes have been more numerous than were ever before reported in a similar space of time, owing to the increasing number of retail jewelers and the better organization of the depredators. Jewelers are not, as a rule, protected as they should be from burglars, especially in country places. It is not a difficult matter for an expert thief to gain access to the average country store, and, once inside, with the modern tools of the trade, they very soon get at the contents of the safe. Retail dealers in the country, living in quiet communities where there is comparatively little crime, apparently think that what they must guard against especially is fire; so that any sort of an iron box, called a safe, that will resist a moderate amount of fire will answer for the protection of their goods. But a safe that will resist a good hot fire will yield readily to the approved burglar implements now in use. Give an enterprising burglar half an hour without interruption to operate on a safe, and, in nine cases out of ten, the contents are "his meat." Once in possession of the valuables, and the gang takes a hurried departure to other fields and pastures new. In this way burglars have been going through the country this summer, each success seeming to embolden them. Retail dealers should adopt every precaution to prevent such robberies. This they alone can do—no one can prevent burglars attacking them if they choose. But the Jewelers' Alliance can assist them in recovering their goods and in prosecuting the thieves. This organization is maintained for precisely this purpose, as we have previously explained. Its membership embraces dealers in every section of the country, and should include every one. It costs but a small sum to secure the protection it offers, which is to assume the cost of following up any burglars who rob a jeweler's safe, to recover the goods, if possible, and to secure the conviction of the thieves when that can be done.

The Jewelers' Association Banquet.

THE NINTH annual banquet of the Jewelers' Association was given at Delmonico's, on the evening of the 8th of November. The members were out in full force, and a goodly array of invited

guests were present to do honor to the occasion. With each returning year the annual banquet of the jewelers becomes a more important event, not only to those who participate, but to the entire trade, inasmuch as it serves as a medium for the cultivation of more intimate social relations between those who hold positions of influence in the trade. The good feeling thus engendered bears fruit throughout the year, and has a beneficial influence upon business transactions, softening the asperities and lessening the friction caused by active competition, and teaching every one a better appreciation of the men who are their active competitors. Like all its predecessors, the ninth annual banquet was a social and gastronomic success. The rooms were elegantly decorated with rare and beautiful flowers, bunting, and emblematic designs in flags, flowers and confections; music delighted the ear at frequent intervals, and while cheering wine and fragrant cigars were moderately indulged in, lively, witty and pertinent speeches were made by numerous gentlemen who were in thorough sympathy with the occasion. Elsewhere we present a report of the proceedings, but cold type fails to represent the spirit of good fellowship that prevailed, or to convey a proper sense of the appropriate jestures and enticing surroundings that gave special point to the witticisms of the speakers, and made their special application to the occasion so keenly relished. The luxuries of the table, so lavishly set forth by Delmonico, were greatly enjoyed, and the Committee of Arrangements was congratulated warmly on the degree of perfection they had achieved in providing for the entertainment of the company. A feature of the event was the cards which designated the seat of each person. Beside each plate lay a beautiful water-color painting, usually a free-hand portrait of the individual himself, indicating some peculiarity of habit. Most of these were good likenesses, and will be carefully preserved as souvenirs of a highly enjoyable evening.

Various suggestions have been made as to varying in the future somewhat the programme for these annual reunions; some have suggested that members be requested to bring their wives, daughters or sweethearts; others have proposed extending the invitations more generally to members of the trade who are not included in the membership of the Association, and to rely rather upon the trade for responses to toasts than upon after-dinner speakers who are not identified with the trade. These and various other suggestions have been made, and will, no doubt, be given due consideration. But the fact remains that many varieties of entertainment for business men have been tried by various professions and trades, and none have been found so satisfying as the banquet, and all finally come back to this. Club life in prominent cities is especially adapted to prepare the average man of business to thoroughly enjoy a genial banquet, and under no other circumstances does he thaw out so completely and become a social instead of a business animal as when seated at the festive board, surrounded by his companionable fellows, with a bounteous repast before him, and the seductive aroma of good wines, good cigars and general good fellowship floating around him. Under these circumstances he crawls out of his shell, built of everyday business cares, and gives free rein to his social qualities. The banquet is, unquestionably, the most popular form of entertainment that can be devised; the arrangement and development thereof is simply a matter of detail.

Sharp Practice.

GERMANY has adopted stringent laws against peddlers, and, of course, human ingenuity is at once set to work for providing ways and means to evade them. Solon, Lycurgus, and various antiquated old fogies have been handed down to us as benefactors of the human race in devising laws for its government, but we believe that if they had lived in this, the 19th, century, they would have become the butt of every third and fourth-rate lawyer of Center

street. By the way, there must have been no boys in the days of Diogenes; if this worthy old fossil had set up his tub here in New York, say on Bowery, he would have found himself sprawling in the gutter within five minutes after occupying his lodging, and while attempting to replace his ash barrel, some one would have stolen his lantern. But this is irrelevant, and irreverent.

The peddlers are highly taxed in Germany, and to evade this tax two of them, belonging to different places, agree to sell their goods. One travels ahead with the stock, while the other, armed with a legal judgment, follows him, and, of course, both meet in the place agreed on. A row occurs between them, the debtor creates all sorts of difficulties, but the tyrannical creditor levies upon the goods, and with magnanimity unheard of, cancels a part of the debt, when both agree finally to have the goods sold by law. This, of course, is the bait to draw a crowd. A forced sale takes place, in which principally the purchaser is sold, and vendor and vendee laugh at the fools.

Verily, we live in an astute age.

A SHORT TIME since H. A. Scofield, traveler for the Lincoln & Bacon Manufacturing Company, was taken sick at the Palmer House, Chicago, with typhoid fever. Many of the other guests in the house were alarmed in consequence, and some of them threatened to leave unless he was removed. The proprietor of the house replied that Mr. Scofield was his guest and entitled to all the consideration that any one of the others was, and, from the fact of his illness, was more entitled to his care and attention, concluding by saying that if any of the guests wanted to leave, they were privileged to do so, but Mr. Scofield was entitled to remain until he got well. A special room was fitted up for him, and he was supplied with every comfort and attention possible in a public house. He was confined for six weeks, and during the whole time the proprietor and his assistants were unremitting in their kindness and attention. While this was nothing more than was to be expected of a gentleman of such high character as Mr. Palmer, it is none the less worthy of recognition. The Palmer House has always been a popular one with commercial travelers, who have been made to feel that they were at home there. All who have heard of the treatment Mr. Scofield received are loud in their commendation of Mr. Palmer's course, and are grateful to him for the consideration shown to one of their number. But the kindness lavished upon the sick guest was not all the delicate consideration exhibited by Mr. Palmer. Knowing, as he did, how costly such a prolonged sickness is, when Mr. Scofield came to settle his bill, he found a very liberal reduction had been made in his behalf. It is so usual a thing for landlords to take advantage of the necessities of traveling men, that such humane treatment of one of their number by Mr. Palmer should not be forgotten, but should make his house more popular than ever with the trade, and, indeed, with travelers in any branch of commerce.

RETAIL DEALERS in the country are frequently imposed upon by manufacturers and jobbers, who have a special line of goods to dispose of, by the offer of what is termed "special privileges." That is, the jobber or manufacturer promises that if the dealer will buy his goods liberally, he shall have the exclusive privilege of selling them in his special locality. This would seem to be giving him an advantage over his competitors, but it usually turns out, if the goods prove attractive, that after the privileged dealer has introduced them and worked up a demand for them, he finds all his competitors freely supplied with them. The "special privilege" thus amounts to nothing when the other fellow finds it to his advantage to ignore it. This little game has been played quite extensively by some par-

ties, the "special privilege" being hawked about a city till every dealer had been taken in by it. But "special privileges" are not confined to the jewelry trade; it is a favorite game played by speculators in the stock of prospective mining companies, "ground floor" and "basement privileges" being the stock in trade of the projectors of mining schemes that promise so well—on paper. Such tricks of trade are unworthy of respectable dealers at the present day. Whatever advantages may have originally attached to "special privileges" have been more than counterbalanced by the deceptions practiced under their guise. Retail dealers usually find that they pay more for goods obtained under such "privileges" than they otherwise would, and instead of being protected in handling them, are used as a medium for introducing them for some one else to reap the profit. The time has come when the dealers should look with suspicion on any one who offers them "special privileges."

WE HAVE received a printed report, issued by W. H. Thorp, Secretary, of the proceedings of the third annual meeting of the Wisconsin Retail Jewelers' Protective Association, held at Madison, Aug. 29. We made a notice of the meeting at the time, and only refer to it now for the purpose of complimenting the Association on the straightforward, business-like report it has sent out. It is a model of brevity and succinctness, containing the pith of the proceedings and omitting the vast amount of chaff incident to such meetings. It shows at a glance the numerical and financial standing of the Association, and we are glad to note that its condition is far from impecunious. Its membership is respectable in numbers, and embraces the names of some of the most respectable and responsible dealers in the State. The Wisconsin Association has always been the most promising of the State organizations, because its members have sought to conduct it upon business principles. If all were like it, and self-seeking men were kept out of them, these Associations could be made a power for good in the trade. We congratulate the Wisconsin Association on the progress it has made, and on the promise it gives of future usefulness.

The Jewelers' League.

President, GILBERT T. WOGLON.....Of Woglom & Miller.
 First Vice-President, JAMES P. SNOW.....Of G. & S. Owen & Co.
 Second Vice-President, HENRY HAVES.....Of Wheeler, Parsons & Hayes.
 Third Vice-President, WM. C. KIMBALL.....Of H. F. Barrows & Co.
 Fourth Vice-President, AUG. KURTZBORN.....Of L. Bauman Jewelry Co. St. Louis, Mo.
 Secretary and Treasurer, WILLIAM L. SEXTON.....Of Sexton & Cole.

EXECUTIVE COMMITTEE.

JOHN D. LYON, Chairman.....Of Lyon & Hardy.
 JOSEPH B. BOWDEN.....Of J. B. Bowden & Co.
 JAMES D. YERRINGTON.....Of J. D. Yerrington & Co.
 ROBERT A. JOHNSON.....Of Colby & Johnson.
 SAMUEL W. SAXTON.....Of Saxton, Smith & Co.
 CLEMENT B. BISHOP.....Of Carrow, Bishop & Co.

EXAMINING FINANCE COMMITTEE.

CHARLES G. LEWIS.....Of Randel, Baremore & Billings.
 CHAS. G. ALFORD.....Of C. G. Alford & Co.
 GEORGE R. HOWE.....Of Carter, Sloan & Co.

THE JEWELERS' CIRCULAR is the exclusive official paper of the Jewelers' League, and has been selected for the publication of all matters of interest pertaining thereto. Letters or inquiries pertinent to its business or purposes, and which might interest the trade or inquirers, will herein be answered. Address *Jewelers' League, Box 3,444, P. O., New York*, or the office of THE CIRCULAR.

In the last number of THE JEWELERS' CIRCULAR we characterized some associations as scalping insurance companies, posing as mutual benefit societies. One of these associations, with an impressively high-sounding title, for the fiscal year ending December 31st, 1882, paid to beneficiaries \$34,250; it used for salaries, agents' fees and other extravagances \$112,191.30. In other words, it spent \$3.28 to place each single dollar in the hands of the beneficiaries. Its original

plan was to place the whole of the death fund in bank, to be used solely in the payment of death claims, which was good evidence of a determination that the fund should not be diverted from the purpose for which it was paid; however, under the plea that the members were, in some sections of the country, taxed for the business done by the association in those places, the managers of that close corporation had its constitution so amended that they could, before depositing the moneys collected for the death fund, deduct "the expenses incurred in collecting the same, state and county taxes, legal and other expenses," etc. What a lovely bonanza for the greedy ex-insurance officials and harpies who are running the institution. The real life insurance people, through their periodicals and pamphlets, are handling that concern and its fellow "scalpers" without gloves. One happy purpose accomplished by these scalpers has been to divert the attention and attacks of the life insurance interest from the actual mutual benefit and benevolent societies, to the scalpers themselves. These latter have, in the course of events been, not of their own volition however, interposed as a shield upon which all the attacks of the "old line" companies are now to be directed; the League and similar benevolent societies may now sit upon the fence and witness the other boys pulling each other's hair and calling each other hard names.

An interesting compilation has been made by Secretary Sexton, showing the distribution of the membership of the League; the Eastern States have 384, Massachusetts leading with 243; Middle States 1504, including New York City and Brooklyn's 1041, of which Tiffany & Co. have 65 and Philadelphia 128; Southern States 176; Western States 683, including Chicago's 199; Canada 20; Paris, France, 2, and London, Eng., 1.

The officers and members of the Executive Committee swing through their work with an ability and a thoroughness which is acquired only by experience. The man who carried a pet calf up and down a flight of stairs night and morning, so gradual was the growth of the animal, that the man was in fact carrying a full grown bull before he was made aware of it by the astonishment expressed at his display of strength. Several of the officers and committeemen who have been with the League since its birth, would find a considerable contrast between their efforts necessary to the transaction of the business if they were to step into the management now without the experience so gradually and almost imperceptibly acquired. As it will be impracticable for the present system of able management to be continued unless at least as able and as interested men are chosen, it will be at once apparent to the members that great care should be used in the choice of successors to those whose terms of office expire at the annual meeting on January 15th next.

There should be a large attendance at the annual meeting, if for no other purpose than to indicate to the officers an interest and watch-care by the members. THE JEWELERS' CIRCULAR echoes the words of a notice of a former annual meeting: "The attendance of every member of the League is earnestly desired, as its future depends in a large measure upon the ability and prudence of the gentlemen selected as managers. Absentees will have only themselves to blame if the officers do not come up to their standard of ability. This meeting is not everyone-else's business, it is your own. Each one of you respectively has a vital interest in its substantial and continued prosperity, and your voice is required in selecting its management." Sound advice. Come yourself and select good men; and in that connection just let THE JEWELERS' CIRCULAR whisper in your ear: After you have selected intelligent, faithful men, who make your interests their study, do not "sit down" on them and their recommendations as inconsiderately as you did at the last annual meeting.

Among the visitors to the office of the League during the past few months we noted the names of Chas. D. Hosley, Springfield, Mass.; H. Frank Payton, Thos. W. Manchester, C. E. Hancock and A. Mesaler, Providence, R. I.; F. W. Pitschman, Brenham, Tex.; A. J. Rand, Holyoke, Mass.; A. J. Warner, R. A. Boyer, Minneapolis, Min.; W. H. Morris, Westfield, N. J.; Wm. A. Bigler, Chicago; E.

W. Clarke, Tallahassee, Fla.; Chas. J. Cook, Emanuel Gattle, Jno. N. Taylor, T. A. Ramage, J. J. Rutan, Newark, N. J.; Frank P. Iannarone, Washington, D. C.; T. B. Lewis, Binghamton, N. Y.; C. E. Rose, Corsicana, Tex.; Adolph Yerger, Hawkinsville, Ga.; Jos. Weisbauer, Buffalo, N. Y.; F. B. Watson, Three Rivers, Mich.; D. H. Robinson, S. Attleboro, Mass.; E. T. James, Sing Sing, N. Y.

At the regular meeting of the Executive Committee, held on November 2d, there being present Messrs. Kimball, Johnson, Bowden, Bishop and Sexton, the following 51 applicants were admitted to membership:

L. L. Deneville, B. P. Traitel, W. Mount, O. M. Farrand, New York City; A. Plenthner, Buffalo, N. Y.; F. Mongin, Oswego, N. Y.; W. H. Bullard, Watertown, N. Y.; M. Weill, F. M. Reynolds, J. M. Parshall, R. Mathewson, H. W. Hartman, I. Bernstein, Chicago, Ills.; S. S. Wood, Elgin, Ills.; J. P. Weatherstone, La Grange, Ills.; C. J. Dunbar, Princeton, Ills.; H. T. Kent, H. B. Michie, T. Cook, Cincinnati, Ohio; H. N. McKean, T. A. Simons, Columbus, Ohio; D. I. Murray, Middletown, Ohio; A. H. Brunner, Cleveland, Ohio; T. H. Watson, Dayton, Ohio; D. A. Hubbard, Akron, Ohio; G. B. L. Pearson, Boston, Mass.; H. Gornley, Attleboro Falls, Mass.; C. J. Bowder, North Attleboro, Mass.; J. N. Webster, Springfield, Mo.; S. Morris, Warrenton, Mo.; E. Hayter, Kansas City, Mo.; E. R. Zahm, Lancaster, Pa.; J. A. Mahaffey, Pittsburgh, Pa.; C. J. Cooke, Philadelphia, Pa.; J. C. Walk, S. S. Goldberry, Indianapolis, Ind.; G. Chillias, Toronto, Can.; B. F. Chadwick, Winnipeg, Manitoba; C. D. Taylor, Mankato, Minn.; F. C. Mallory, Tracy, Minn.; C. O. E. Hartung, New Haven, Conn.; C. H. Laird, Camden, N. J.; H. Kretschmar, Omaha, Neb.; H. W. Lyon, Richmond, Va.; J. R. Broadstreet, Talladega, Ala.; L. H. Bosworth, Providence, R. I.; H. A. Goldbach, Des Moines, Iowa; E. B. Dikeman, Grand Rapids, Mich.; M. Steinberg, Savannah, Ga.; Thos. W. Ward, San Francisco, Cal.; making a total membership at this time of 2,887.

Two applications were rejected and twenty were laid over for investigation; seven requests were granted for change of beneficiary; 28 members were deficient in promptness of response to assessment No. 21 within the prescribed time, and were dropped from the roll; of these, 25 were re-instated after satisfying the Committee by explanation of their delinquency, and one is under consideration. A reasonable excuse is always entertained by the Committee, but a few, happily a very few, chronic late men, may, one or more of them try the patience of the Committee beyond the point of official endurance.

The Treasurer reported \$3,838.05 in the general fund and \$5,355 in the benefit fund.

A double assessment, Nos. 22 and 23, was ordered on account of the deaths of W. J. Doherty and L. A. Cuppia, and the notices were sent out to the members about Nov. 8th. On Nov. 7th a check for \$5,000 was paid to the beneficiary of W. J. Doherty.

[Copyright Secured.]

The Cup—Its Art and Customs.

[BY JOHN W. MILES.]

Continued from page 309.

THERE ARE three other *pateras* in the same collection, one bearing a figure beaten up in high relief of the infant Hercules strangling the snakes sent to destroy him, the second having a bust of a deity, and the third with a bust of Cybele, mother of the gods and of nature. A beautiful example of Greek art is a silver cup formerly in the museum of the Collegio Romano in Rome, and now belonging to Sir William Drake. Quoting the South Kensington Museum description, "the bowl is a half egg in shape, with a plain torus moulding round the mouth, a slightly expanding foot with a similar moulding round it. It measures four inches and three-eighths by three inches. Round the body of the cup are three full-length

figures. One is a half-draped woman, seated; she has her hands on the head and beard of a small terminal figure, a sort of sylvan deity, having the attributes of Hercules, pouring a libation round itself. A post with a mug (perhaps a cap) on the top of it, is behind the terminal figure, and the whole is overshadowed by a tree. In front, on and under a square table supported on turned legs, are wine cups and vases of different sizes, elegantly shaped, and some on a scale so small as to be less than a quarter of an inch high. All differ in outline, and seem to range from the *crater* to the smallest drinking vessel and such as would be used for pouring the libations with which a meal was prefaced by the ancients. As we see them they seem to be offerings to the sylvan deity. The other figures are a bacchante and a male figure, both under the influence of the wild orgies of the worship of Bacchus. The woman is dancing, her head raised and turned upwards, and her arms gracefully extending the veil or scarf which is held by the two hands. The man is also dancing or moving to a measured step, holding a *thyrsus* and the skin of a leopard. These figures are gracefully posed, and the limbs and other details are worked out with a perfect knowledge of the human figure. They represent traditional attitudes handed down from the designs of Scopas or perhaps rather of Praxiteles. It was found at Vicarello near Rome in the Aquæ Apollinæ. It is not probably of earlier date than the Augustan age, and is the work of Greek artists of that period."

Water was the primitive beverage of the Greeks. When wine was introduced it was universally diluted with water in the proportion of two of wine to five of water, and the mixture was often highly perfumed. At the conclusion of a banquet fresh tables (*cilibantum*) were provided, upon which were arranged the censers, the goblets and the ladles of silver or gold for filling the smaller cups. A chief called the King of the Feast was then selected, sometimes by throwing the *astragali* (a sort of dice), sometimes by popular choice, who exercised supreme power over all present, and determined how much or how little each man should drink. He also decreed the proportions in mixing the wine, imposed fines and directed the dancing, music, feats of agility or other diversions. Large bowls or *craters* of wine duly mingled with water were placed upon a sideboard, when the cup bearers, provided with ladles, filled the goblets of the guests. When the froth rose above the brim the goblets were said to be "crowned." Small cups were served at the beginning, with larger ones reserved for those who were fined, but before the close of the symposium the larger goblets were used exclusively. Of the latter some were of a capacity sufficient to hold a quart, and instances are mentioned of some holding half a gallon. They had to be emptied without taking breath. Among the Doric Greeks, as with the Ptolemies of Egypt, female cup bearers seem to have been preferred, and the people of Tarentum, passing through every phase of luxury, at length chose to be served at table by the most beautiful young girls entirely nude. These were ordinarily slaves, but it does not appear that the service was at all derogatory to those of noble blood. Beauty was an imperative necessity, and the pleasure derived from its contemplation was purely of an æsthetic nature, although among the young such a custom undoubtedly provoked additional sacrifices to Aphrodite. When the goblets were crowned the Master of the Feast began drinking the health of his guests, beginning with the most distinguished. At first whoever drank to the health of another drained his cup, but later it became the custom to merely sip a portion of the wine, while the recipient of the toast finished the cup or drank one of equal size. Among the most popular diversions of the symposium was the *Cottabus*. This game consisted in throwing wine out of a cup into a brazen basin so arranged that the weight of the wine would cause it to descend, and, striking against a small bronze statue called the *manes*, produce a certain sound, or, by a similar throwing of wine, to drown little bowls swimming upon the surface of the water. Cups were appropriated for prizes in this game, and success was considered a good omen in love matters.

The ordinary drinking cups of the Greeks were small, and among

the Spartans particularly, where abstemiousness was universally observed, they were very diminutive. When they wished to indulge themselves they had larger goblets than those commonly used. At every entertainment, temperate or otherwise, the gods were not forgotten by this deeply religious people, nor was the dinner served without the opening ceremony of the libation of wine. Following the gods absent friends were remembered, and these, placed nearly on a level with the divinities, were pledged in undiluted wine. Among the young, in whose affections a mistress naturally ruled paramount, a quaint custom prevailed of pledging their beloved in as many cups as there were letters in her name, which, if unusually long, would prove dangerous to sobriety. The dilution of the wine and the remembrance of things connected with the highest and holiest emotions of both mind and heart would seem to indicate that the Athenian Greeks, at least, quaffed their wine less for its own sake than for the poetical sentiments which it conveyed, but among the Macedonians these considerations had little force. Accordingly, drinking bouts were not uncommon in Macedonia. Plutarch briefly describes one of these occurring after the death of Kalanos the Hindu Yogi. Alexander, entertaining a number of his friends and generals, proposed a drinking contest, offering a crown of gold to the victor. The winner was Promachos, who drank two gallons, and died in three days. The number of guests is not given, but forty-one of them died from the effects of the indulgence on the spot, and six more afterwards in the tents. Alexander himself possessed a remarkable power of drinking, in which he indulged to excess. In one of his drunken fits he stabbed his most intimate friend Clytus, and his own death, in fact, was indirectly caused by intemperance. Being at Babylon, where the climate allows few excesses, he attempted to pledge Proteas, another heavy drinker, in a goblet more like a pail than a drinking cup. The wine was taken, but the goblet dropped from his hand, his head fell back upon the couch, and a fever ensued that in a few days overthrew the "Conqueror of the world."

Cups, goblets and other drinking utensils were very popular gifts among the Greeks. At marriage feasts especially the first article served was a silver beaker of wine, the cup and contents being a present to the guest, and later on it was often arranged that every man should reckon as his own the bowl whose contents he could drink. Yet they were not, as a people, dissipated. On the contrary, drinking to excess was considered disgraceful, and drunkards were accounted infamous. Especially was this true among the Spartans, who often compelled a slave to drink himself into a state of beastly intoxication, as an example to their youth of the evils of intemperance.

After the battle of Corinth, Greece became in reality a part of the Roman empire, and the genius of that sensitive race, that under the consciousness of freedom and independence created such marvellous and beautiful works of art, began to degenerate. When the character of a nation declines, all the qualities of mind and heart that flourish under a refined and cultivated condition of society, decline also. Large quantities of their productions were transferred to Rome and were highly valued by their new possessors. "If the Greek was unable to live without art, the Roman was but little less so. What one craved as an intellectual enjoyment the other required as an attribute and symbol of his magnificence." Every form of art, therefore, poured constantly into Rome, the greatest quantity at any one time being caused by a real or feigned debt owing by the people of Sicily, the entire production of that ancient and prosperous school being taken in liquidation. Everything that was of Greek production had an immense value, more especially if it was the work of the older masters. The rage for the antique was a passion exceeding anything of modern times. We learn that Lucius Crassus the orator had two silver goblets chased by the hand of Mentor (who worked nearly three hundred years previously) that cost him one hundred thousand sesterces, and other instances are common where fabulous sums were paid for specimens of Greek workmanship executed when Grecian art was at its zenith.

Most of the forms and principles of classic art have come down to us through the channel of Roman transmission, and so clearly defined are the lines of difference between Greece and Rome that wherever the latter has combined her own ideas with those of the former the innovation can be easily detected. Compare the Grecian classic vase in figure 14 with the Roman work in figure 15. Observe the beautiful ovoid lines of the former in all their purity of symmetry and

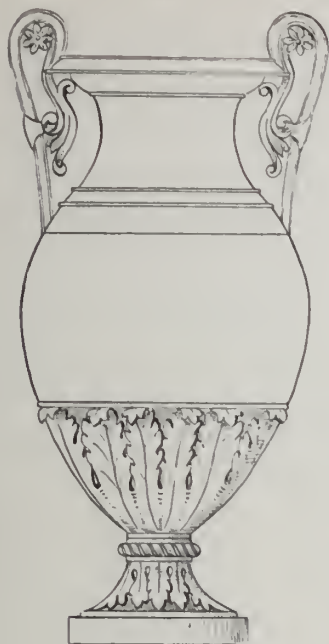

Figure 14.

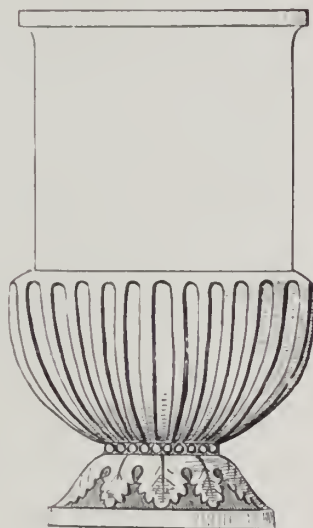

Figure 15.

grace and the lack of refinement and attractiveness in the latter becomes still more strikingly apparent. In fact Rome was entirely destitute of originality. Although the Romans derived their first knowledge of art through the Etruscans, it soon became essentially Greek, and the few productions of Roman artists were mainly copies from the Grecian masters, and often devoid of the sentiment which only the original genius could impart. The Roman patrician was certainly often highly educated, and fully realized what art was, but he was wholly unable to create it. Rome, therefore, became full of Greek artists, who produced the larger portion of articles in gold and silver besides what may have been imported from their native cities, but though some portion of their skill still remained, sad as it may seem, it did not exceed their abject servility.

Chalices with a low foot, figure 16, were made of glass as well as silver and gold, and drinking cups were in use having the interiors filled with concave facets, like mirrors, so that one who drank could see reflected a multitude of persons. But these productions were by Greek artists under Roman dictation. Rome herself was destitute of the genius of creation. The constant employment of her resources, both material and mental, in almost continuous warfare, debarred her from the leisure necessary to the development of perfect ideals. Under the kings, the ordinary wants of life and outside wars occupied them during two centuries or more, while, under the consuls, their attention was directed not only to foreign conquests but also to the internal dissensions between the patrician and plebian classes. After the second Punic war a gradual change of manners and habits took place at the imperial capital. Fifty years had chronicled the conquest and sack of many Grecian cities, including Carthage, and the homes and temples of Rome were filled with not only the material wealth but also the art and culture of Greece. But absorbed in the "arts of war," Rome had neglected to cultivate the "arts of peace." "Mistress of the World" she might be in arms, majestic in the power of her government, and magnificent in the display of her enormous wealth, but in acquiring these things she failed to acquire also the knowledge of how to rightly use them. Elated with the success of her legions, inordinately enriched with the spoils of numerous conquests, and with morals corrupted by long periods of unrestrained pillage of conquered countries, she could form no higher

conceptions of pleasure than those of the voluptuary and sensualist. Articles of use or ornament were valued, irrespective of every other consideration, solely upon the basis of cost. The most rare and expensive food was served at their banquets in vessels of gold, while the guests reclined upon the most luxurious couches of gold or silver. The palace of Nero fairly blazed with the multitude of jewels, and the houses of the noblemen had ceilings of ivory, so contrived that they could be opened and admit showers of perfumes and flowers. Halls were hung with cloth of gold enriched with jewels, and floors were covered with carpets imported from Babylon at enormous



Roman Chalice, Figure 16.

expense. Apicius, having wasted over two million dollars in these extravagancies, committed suicide because the four hundred thousand dollars he had left would not allow him to continue the indulgence; and Verus, having invited eleven friends to supper, afterwards presented each with living animals or birds similar to those which had been served, together with the costly cups of gold or crystal from which they had drunk and the page who had served each guest. They were also sent home, each in a splendid carriage, which, with the mules and driver, was a gift. But society was not merely extravagant, it was licentious. Greek forms, in all their purity of outline, were debased with decorations of the lowest and most obscene character. In cups, especially, the Romans took delight in engravings of libidinous subjects, or figures in relief of most indecent forms, and this abasement of taste eventually ruled in the shapes of the articles themselves. The nude, which, in the hands of the Greek, insinuated naught but chaste and pure emotions—lifting them above the material into the spiritual—suggested to the Romans the vilest thoughts of lasciviousness and debauch. The excavations at Hercolaneum and Pompeii have yielded many objects unfit for public exhibition, but in the later days of Rome such articles were far from uncommon. Such was the native art of Rome, too feeble to earn a distinctive classification, and too base for enumeration before ears polite.

Regarding the drinking customs of the Romans little can be written. The gallants had a habit of drinking as many glasses as there were letters in the names of their mistresses;

"Six cups to Naevia's health go quickly round,
And be with seven the fair Justina's crown'd." *

but this was also a custom of the Greeks. In fact the later days of Rome were characterized by the adoption of all forms of foreign dissipation, while her principal men racked their ingenuity to devise still lower practices. The wine was often cooled by passing it through

* Martial.

strainers filled with snow or small pieces of ice. Healths were drunk to friends and sentiments, and, under circumstances especially enthusiastic, the chaplets crowning the brows of the guests were thrown into the wine, and this was called "drinking the crowns." Previous to the battle of Actium, Anthony, suspecting that Cleopatra intended to poison him, refused to partake of anything from her table without she herself first tasted it. Cleopatra, laughing at his fears, provided herself with a wreath of poisoned flowers, and, after supper, proposed to drink the crowns. Anthony gallantly threw her's into his cup and was about to drink when she arrested his hand and apprised him of the danger, thus proving her honesty. The chaplets were not always of flowers. They were often of ivy, vervian or parsley, these plants having, they believed, the property of preventing intoxication.

Gluttony was indulged to an excess, requiring emetics to relieve an overburdened stomach, in order that eating might be continued. Tongues of peacocks and nightingales, heads of parrots and pheasants, livers and brains of small singing birds, were served in profusion upon their tables. Pearls were dissolved in wine and served to guests. Viands especially provocative of thirst were also served.

"Stew'd shrimps and Afric's cocks shall excite
A jaded drinker's languid appetite."

Also,

"Grapes and apples with the lees of wine,
White pepper, common salt and herring-brine." †

while Pliny states that the men of best society, having drunk to repletion, still continued to take goblet after goblet in order to provoke nausea, and, having regorged, began again, repeating the operation several times at the same sitting. The few feeble voices raised against such extravagant beastiality were unheard. The wild and drunken gibes of the Roman youth who irreverently held the cup of fiery wine to the marble lips of a sculptured Cæsar received no rebuke from his maudlin companions. Respect for genius of any kind no longer dignified the minds of men, and the greatest glory lay in the deepest and most costly forms of licentiousness. The "noble Roman" became ignoble, and constantly enervating himself with excesses slowly but surely undermined that astonishing power that once electrified the world. Weakened into effeminacy by indulgences, the Romans were no longer able to bear their armour, and the frugal barbarian tribes, taking up the discarded shields, step by step overthrew the empire.

But while Rome resounded with the ribald shouts of drunken orgies a little child was born and humbly cradled in a manger. Art was to receive a new life and purpose in a different religion, fresh themes and symbols were to replace the old, and failing genius was to receive a new inspiration. For three centuries the light of Christianity slowly permeated society, shining, now brightly now dimly, yet ever surely, and constantly supplied with fuel in the blood of its martyrs. The debased and cruel pleasures of Rome had sent many of its votaries into the arena of wild beasts or to meet death in other forms of most excruciating torture, but after the cross in the sky flashed before the eyes of Constantine the new religion gained strength and spread its influence over not only the hearts but also the imaginations of men, and we find the old mythological beliefs slowly fading away and becoming less and less a religious inspiration, giving place to the new creed. Classic art, fast decaying under the influence of the depraved and vitiated taste of Rome, received but a slight revival from the protection of Constantine. The thoughts of men turned into new channels had not time during his reign to accommodate themselves to the new order of things. The new capitol established at Constantinople absorbed the larger portion of the magnificence of Rome in articles of *vertu*, but the art established there was but the mere shadow of the old Greece-Roman genius. The light, graceful forms that once pleased the Grecian eye were supplanted by more complicated shapes and outlines. Human figures no longer revealed the passions and emotions of mankind, nor did the idealized beauty of the human form represent the perfection of gods and goddesses.

† Horace.

The austerities of the new religion found expression rather in the wasted forms of martyrs, prophets and apostles. The sorrows of the virgin, the temptations or triumphs of the saints, and the mysteries of the cross served as an inspiration for the artists of Byzantium. In the 5th century gold and silver was very abundant. The silver column of Theodosius, appropriated by Justinian, weighed seven thousand and four hundred pounds; the offering of Pope Symmachus to the basilica of St. Peters at Rome amounted to one hundred and thirty pounds of gold and seventeen hundred of silver, and the basilica of St. Sophia at Constantinople contained forty thousand pounds weight of silver. The great amount of the precious metals thus poured into the churches was in different forms, or was made into articles for sacred use in the cloisters, where gold and silver work appears to have been confined. Altars, censers and other vessels used in the services were of the most valuable materials, and it is, therefore, in the sanctuaries that we must seek for illustrations of art during an age unable to entirely overcome old traditions, and too weak in capacity to thoroughly establish the new inspiration. An Abyssinian chalice of massive gold, figure 17, now in the museum of South Ken-



Abyssinian Chalice, Figure 17.

sington, has been accepted as a type of the art work of this early Christian period. The cup is a wide, shallow basin beaten out into a flat rim at the edge, which is slightly waved. The outside is plain, but around the upper surface are two lines of inscription rudely engraved in Amharic characters. The stem contracts below the basin, a row of double C-shaped ornament coupled together running around the uppermost band at this part. The base of the foot bears a second legend. It is a lingering tradition of the *patena* and a striking example of the inability of the early Christian artists to entirely free themselves from the hated art of paganism. During the Romanesque period we find much more attention given to ornamentation than to form, a great part of the work being in highly colored enamels and rich in symbolism. The delicate simplicity of Grecian design and workmanship gave place to a style solemn and



Tassilo Cup, Figure 18.

severe, although complex and set off with the utmost magnificence and richness of material. But the beautiful works of classic art were no longer possible. The genius that produced good designs and refined details had long since passed away. A German chalice

in the monastery of Krems münster, figure 18, belonging to the 8th century, and presented by the founder Duke Tassilo, shows every possible point taken up with symbolic and elaborate decoration, while the shape is cumbersome heavy and ungraceful.

(To be Continued.)

The Spherical Clock.

A LATE NUMBER of the *Revue Chronométrique* contains a description by M. Paul Garnier of a highly remarkable old clock, the cuts accompanying the article, which we reproduce, and which, on account of its great rarity, will doubtlessly be of interest to our readers. We do not believe that a second one is extant, at least we have never seen or read the description of one.

The clock is of French construction, dating to the beginning of the 17th century, and is propelled by its own weight, being contrived

is fastened upon the surface. An arbor, which forms the prolongation of the sphere's axis, issues from the lower hemisphere. This arbor makes one revolution per hour, and carries a hand which stands before a small dial, divided into four quarters, being the quarter hours, as will be seen in the cut. This hand also serves for setting right the hour hoop.

The wheel work is contained between two plates, fastened upon the inner helical frame. It consists of a drum with fusee snailing, together with a number of wheels and pinions, and is provided with a vertical escapement. A wheel, which moves the hoop as well as the axis in the ball, stands in depth with the train. The cord, which passes through a tube, and issues from the capsula above, is with one end fastened upon the drum; while the other end serves for suspending. The peculiarity in the arrangement of the drum provided with fusee snailing consists in that it serves at the same time as spring barrel, for which purpose it contains a mainspring. Now, while the sphere sinks by its own weight, whereby the drum is revolved, the cord unrolls and the spring is wound. After the sphere has, by the going of the clock, gradually sunk to a certain point, in other words, that the clock has run down, the sphere is raised again, when the tension of the spring will wind the cord, and the winding of the clock is performed in this manner without a key.

The balance is of iron and has two arms.

The scape wheel is of a large diameter, as is the case in all watches and clocks with escapements dating prior to the invention of the balance spring, when the weight of the balance was the sole regulator. The balance spring, with which the clock is provided at present, has doubtlessly been added at a later time, as can be seen from its arrangement and the hole drilled through the capsula for the passage of the arbor for regulating. The balance spring is of a very peculiar form; it barely has one coil and ends in a straight-line prolongation of 15 mm. (0.6 inch), which is fastened in a slide between two cheeks. This slide can be moved backward and forward.

The screw, which moves the slide, and whose end protrudes outside, served for regulating the amplitude of the balance when it did not yet possess a spring; this was a make-shift frequently employed at that time, especially with timepieces which, in place of a balance, were provided with a "foliot" (arbor with cross piece, upon which the regulating weights were hung in notches).

It is a pity that the piece carries not the name of the maker.

The cut will sufficiently explain the clock.

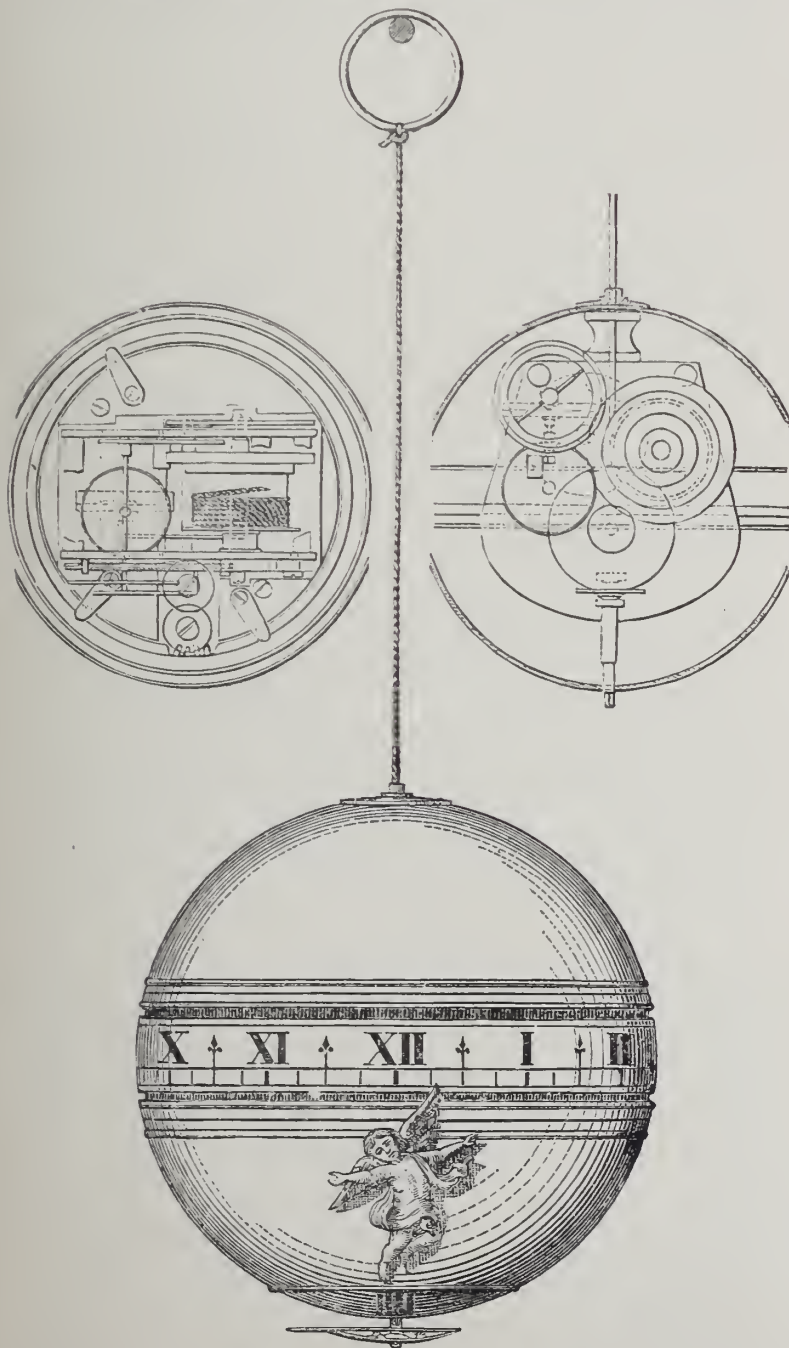

in such a manner that it can be suspended. It consists of two hemispherical capsulas, of gilt copper, which are fastened to an interior frame, in such a manner that a free space is left between the two, in which a ring or hoop can freely revolve. The quarter, half and full hours are engraved upon the surface of this ring. The hours and their fractions are indicated by the point of the angel's wing, which

Two Green China Jars.

A COLLECTOR'S TRIALS AND TRIUMPHS AND WHAT CAME OF THE STOPPING OF HIS BUHL CLOCK.

I.

A WORTHY burgher of Haarlem, an enthusiastic collector of curios, who flourished in the middle of the Chinese porcelain epoch of the last century, having purchased at a fancy price a green vase, took it home and placed it at one end of his chimney-piece. During a period of several days he admired his new possession with the intense admiration of a collector who has carried off a prize coveted by his rivals, but suddenly he was horror-stricken at the discovery that he did not possess a companion jar—that the opposite end of the mantelpiece was a howling wilderness, and the whole arrangement marred by a fatal lack of symmetry. Shuddering at the horrible prospect thus unfolded, the worthy burgher swore never to rest until he had found a match for his precious jar.

II.

It was only after several months of anxious research that he found the desired vase in the back shop of a Jew, at Antwerp, who made him pay two thousand mortal crowns for it. Yet, after all, this was not too much for the delight of possessing two green China jars, each as like the other as pea is like pea, and stamped with the mark

of the Ming dynasty. Hurrying back to Haarlem, he placed, with infinite precautions, the second vase upon the further corner of the mantelpiece, and sank back into his easy chair to observe the effect. At last he had them both, one at each end, equi-distant from the buhl timepiece in the middle; and the declining sun, envious of the sight, shot a ray of light in through a tiny pane in the leaden lattice and left a luminous spot dancing upon that nearest the window.

The good Dutchman, his countenance radiant, his eye beaming, sat in an ecstasy of enjoyment and closed his eyes in rapture and peeped again, and closed them again, till at last his breathing had the regular cadence of the grave notes of a violoncello. He was asleep.

Then—a thing strange to see—the two jars began to move slowly but steadily towards each other!

III.

Some thousands of years before the Christian era, as the young Emperor Tchin Tang was walking about his pavilion of lacquer work, he beheld crossing the Bridge of Jade the beautiful princess Tea Flower. Marveling at her beauty, he waved his fan towards her, but the young girl, blushing at the discovery that he was watching her, sprang lightly into her palanquin and was swiftly carried away by her four stout bearers.

Next morning the Princess reappeared upon the bridge, and Tchin Tang, hurrying to meet her, invited her to take a sail upon the bosom of the Yellow River. The Princess graciously accepted the invitation, and they entered the Emperor's boat, where she seated herself in the stern sheets beneath the shade of her parasol, while her lover kneeled amidships, and, strumming his melodious *kin*, sang to her the sad yet hopeful expression of his passion.

IV.

The beautiful Princess was deeply touched by his song, and tears fell from her gentle eyes like pearls.

Then the Emperor said, "O Tea Flower, how beautiful you are! Kneel with me before the altar of the great divinity Fo, and become the mother of the Tchin dynasty!"

But the Princess answered with a sigh, "O, my Prince, do not let us contract a union for time alone. The brightness of my eyes which dazzles you will not last longer than the color of these flowers. To-morrow, perchance, I may be nothing more than the dust of yonder roadway. For what has the poet said? 'Tread lightly, for the dust beneath thy feet is made of the snowy breasts, and the rosy lips, and the fair foreheads of the beautiful.'"

For all reply Tchin Tang seized her in his arms and embraced her so ardently that the frail bark keeled over, filled and went down, and at daybreak the next morning the mandarins found the Emperor and the Princess, locked in each other's arms, floating upon the waters of the Yellow River under the Bridge of Jade. Amid the lamentations of the whole people the remains of the two lovers were buried in a splendid temple upon the flank of the mountain of King-te-Chin.

V.

By the second century of our era, sixteen dynasties having meanwhile reigned over China, and the divinity Tai-Kai having replaced the god Fo, no trace remained of the mausoleum of Tchin Tang.

The famous ceramic artist Tchou, while exploring the mountain, was gratified beyond measure at the discovery that it presented an almost inexhaustible supply of the very finest quality of kaolin earth, and, establishing his factory at its foot, proceeded to the manufacture of those wonderful wares with which his name is identified by an admiring universe of collectors.

Not a vestige was left of the temple, the tomb, or its occupants. Time, the devourer of all things, had converted them all impartially into dust, and Tchou, the artist, made them all impartially into jars and dragons, buttons and gods—made the dust of Tea Flower into the first jar that had been purchased by the good burgher of Haarlem, and the dust of Tchin Tang into the match for it that he had found in the bric-à-brac shop at Antwerp.

VI.

To such of my readers as are familiar with the doctrine of Molecular Attraction and the Indestructibility of Matter, the fact that these two green China jars recognized each other will not seem in the least surprising. So powerful was the influence they exerted upon each other, that in the course of a couple of hours they had traversed a space that for jars like them was absolutely enormous. But, alas! as they neared the center of the mantelpiece they found their further progress barred by the interposition of the buhl clock, sluggish and wholly lacking in the sympathy due to sundered lovers, against which they pressed in vain, and round which they vainly strove to edge.

At this moment the good Dutchman awakened with a start. His first glance, naturally, was in the direction of his cherished jars, and great was his surprise to find them squeezed up against the clock! He could have sworn that he had placed them at different ends of the chimney-piece, and being ignorant of the doctrine of Molecular Attraction and of the identity of the two jars, he contented himself with remarking that he must have been dreaming; and restoring the jars to their former positions, he went off to bed, locking the door carefully behind him.

VII.

Great was the stupefaction of the good man when, on unlocking the door next morning, he found the two jars fairly glued against the clock!

Convinced that some member of his household was playing a trick upon him, he seized the two jars rudely and pushed them back to the corners of the chimney-piece so rudely that he jarred the clock, and it stopped.

There was nothing for it but to carry the clock to the clockmaker in the adjoining street, and, as the timepiece was one of Boule's masterpieces, and the Dutchman was prompt and methodical, he resolved to take it himself that very instant.

Accordingly, bestowing it under his arm, he went, carefully locking the door behind him.

VIII.

Scarcely had the key turned in the lock than a thrill shot through the two green China jars; they trembled visibly for an instant, then tipped and whirled with inconceivable rapidity across the mantelpiece. They met, they touched, they grew to each other. Soon there was but one jar, and as the particles sought each other to intermingle in closest union, it grew upwards, till instead of two jars at different ends of the mantelpiece, there was a single vase in the center, tall, slender, graceful, precious to the eye of any one but a collector whose specialty was green china, manufactured by Tchou under the Ming dynasty.

Tchin Tang and Tea Flower were re-united at last!

IX.

But the Dutchman, when he returned, dropped his precious clock and fell upon the tiled floor in a dead faint.

They bled him and dosed him and brought him to. But he was a hopeless madman.—*Translated freely from the French of Charles Richard.*

The Manufacture of Mainsprings.

[By M. GROSSMANN, in his *Notiz Kalender für 1884.*]

IT IS AN entirely unjustifiable feature of the Germans to regard everything emanating from their native soil as if inferior to that offered them by foreign countries. How often are we pained to see that the most worthy productions of German artistic pursuit can only be introduced under the guise of a foreign label, while the door remains closed to the introduction of the article, or at best it is regarded with depreciation, as soon as its origin is proclaimed openly and honestly.

Every man who has the good of his country at heart should con-

tribute with all the power at his command to discountenance this weakness of the nation, since it not alone detracts from our national honor, but renders home productions dearer, and assists in permitting legitimate profits to be shared by persons not entitled to them.

* * * * *

With this species of articles must be ranked the piercing saws and mainsprings of J. N. Eberle & Co. The business was established in 1836, from the most unassuming beginnings, starting only with piercing saws, which are an ancient article of manufacture of Augsburg. The first trials to manufacture mainsprings only date to 1857.

The use of steel springs for motive power of clock works must be very old, since they were a fundamental principle of the watches invented by Peter Hele toward the year 1510, while clocks were, without exception, actuated by weights.

The mainspring, which serves as the motive power of watches, and many of the clocks constructed at a later date, requires the finest and best rolled sheet steel. This is, up to date, manufactured only in England, France and Switzerland, and of these the productions of the two last named countries are especially famous on account of their handsome, uniform article.

The raw material is chiefly obtained from Sheffield, in the form of square or flat bars, and is in a glowing condition rolled out to a thickness of about 0.8 millimeter. These ribbons are rolled up and placed in cast iron, hermetically-closing receptacles of about 30 or 40 centimeters diameter, and about 20 centimeters high, which are then filled with charcoal dust, closed, and for 24 hours glow heated in large furnaces. This process is, in the course of cold rolling, repeated as often as necessary, so that the steel reduced to the desired thickness also retains the necessary elasticity. France and Austria at present manufacture their own bar steel.

There are only about ten such rolling works in France and Switzerland, which are propelled by large steam or water motive power of from 50 to 500 horse power. The firm of Eberle & Co. obtains its raw material from the best three of these rolling works. Nearly each one of these steel ribbons is of a breadth of from 50 to 80 mm., and a length of about 30 or 40 meters; is very uniformly rolled, soft and mild in quality, and in all respects of a condition rendering it eminently appropriate for its purposes.

Two kinds of springs are manufactured; they are: springs for watches and for large clocks. Both kinds were, in former years, almost exclusively obtained from France and Switzerland, until the firm above named commenced their manufacture in 1857.

The manufacture of watch mainsprings, again, is divided into those for cylinder and for anchor watches, and sometimes for the old verge, as well as for those of the English lever escapement, beside the American springs with hooks of various patterns.

Each of these kinds, from the condition of the above mentioned crude material down to being ready for shipment, has to pass through about 36 smaller and larger processes, and we will endeavor to describe them in the following, for which purpose I invite the reader to accompany me on a visit through the different rooms, so kindly thrown open to our inspection, and accompanied by the affable owner, who explained the different processes.

After a hasty tour to the counting-room, our thirst for knowledge is put to an additional stretch by the invitation of the gentleman to first fortify ourselves with a breakfast prepared for us by his kind wife. We therefore descend to the rooms of his stately mansion, and have the honor of becoming acquainted with his amiable spouse and two handsome children.

Breakfast dispatched, we commence our rounds, and first enter into a room in the basement of the large back building, in which we perceive a number of workmen, who cut, with very suitably constructed shears, the steel ribbons into springs of a prescribed length and breadth. It is extremely important to adhere with great fidelity to the directions, in order to save both labor and material, and very exact machinery is devised to effect this as closely as possible.

But in spite of all exactness, a very trifling difference of breadth exists between them, wherefore the springs are fastened by dozens in the filing machine, and drawn to and fro, under a slight pressure, between two stationary files, until the inequalities resulting from cutting are removed.

The next operation is the so-called "Mollmachen," (finishing). For this purpose, every spring is singly fastened into a bracket frame, and its flat sides are passed first through a filing and next through a grinding apparatus of lead, in which it is freed of its crust and oxide, by means of emery and oil, as well as from the burrs created by the previous working of the edges; at the same time the spring is well stretched.

When this has been done, the springs are bound together with fine wire, in such a manner that between the single coils sufficient room remains in which the oil or fat used for hardening can enter. The springs, tied thus very closely, resemble a cobweb; from six to twelve dozen, according to size, are united into one package.

These packages then enter into the hardening room. This is a strongly arched apartment, with a large furnace, which must be built with great care and have a good draught; that the springs do not come directly in contact with the fire or charcoal, but, at the same time, that they may be heated uniformly, they are laid in a muffle—that is, in a space which is surrounded by the flame, from which they are effectually excluded, however. After the furnace has been heated for about three hours, and the walls of the muffle have become red hot, a cast iron turning table is placed in and heated equally. When sufficiently hot, the package of springs is laid upon it, and, while constantly revolving the table, the springs are heated uniformly to a cherry-red heat.

This done, the package is annealed in a large kettle, filled with oil or tallow, whereby the contents of the kettle is left at the lowest possible temperature by coils of cold water pipes passing through.

The package is now taken out, the springs are loosened, cleaned, and both ends glow-heated. Each individual spring is next again fastened into an annealing apparatus, with two tongs, and annealed. For this purpose the workman has an arched plate of steel or copper before him; a gas flame, with Bunsen burner, burns in the arched part, whereby the apparatus is constantly heated. The workman draws the fastened spring over the plate, and so great is the dexterity of these people, that they know to a nicety how to impart a higher or lower degree by a quicker or slower motion, whereby the spring is annealed properly with only one draw.

Every watchmaker will readily understand that the hardening and the annealing are the most important operations in the entire manufacture, and these two processes can be confided only to experienced and conscientious workmen; by carelessness the entire product is rendered almost valueless, and the greatest attention in the subsequent treatment cannot correct the neglect.

After the springs have obtained the necessary pliability and elasticity by this annealing, they are polished. This is done by fastening them in the two tongs of the polishing bank, in which they are gradually drawn through jaws of lead and three different jaws of linden wood, with oil and emery of graduated fineness. To also finish their edges, they are drawn through three different boxes with six fine notches. The most careful polish of the faces and edges is desirable, not alone for the sake of good appearance, but it also increases the utility of the spring, while a badly polished article, by force of the friction of its coils, may directly lead to a standing still of the watch. The higher and the more carefully a watch spring is elaborated and polished, the tougher, more elastic and durable it will be in its action.

After the springs have been polished very highly, they are annealed again, whereby they receive a good, uniform color. This annealing is not for the purpose of altering their hardness, but to give them a good appearance and to protect against rust. It would be very erroneous to assume that the springs which are found in commerce, with a yellow color, are hardened and only annealed yellow. Such

springs would be far too hard, and would burst at the first winding, if not at the time of being wound in.

For this purpose are used the little gas furnaces which I described previously. They are the invention of this manufacturer, and cleaner and quicker work can be done with them than with any of the auxiliary means used by his competitors.

Here, again, we are forced to admire the marvellous skill and dexterity with which these workmen can anneal thousands of springs at the required shade of color. For many purposes and markets the springs are made of various colors—yellow, red, violet and dark blue—and these shades and colors are by no means an indication of the hardness of the spring, which, as has been said previously, is entirely regulated by the first annealing, while the second color is simply for ornament.

We next enter into a light, spacious room, in which both men and boys are occupied. The latter have to pass through a three years' apprenticeship, and in time Germany will possess a good body of efficient workmen. The springs are cut to their proper length here, and assorted with regard to their strength. The latter is no easy task, by any means, since the thicknesses of the springs range from 0.15 to 0.3 mm., and it requires a good deal of practice, as well as very exact utensils for measuring, to assort the different numbers with appropriate exactness.

According to an old rule of watchmakers, the mainspring, when put into the barrel, is to fill one-third of the space, while the thickness of the core is equal to another one-third; the remaining one-third corresponds to about 13 or 14 coils in the barrel, and consequently a thickness of from $\frac{1}{8}$ to $\frac{1}{4}$ of the interior barrel diameter, and a total development of the spring of 6 to 7 coils. The length which it must have by these proportions is easily found by calculation, and the springs which until now were rather long, are here shortened to their correct length, and glow-heated at both ends. They are next perforated with a stamp, the ends nicely rounded, and wound upon the spring winder for sake of test. If no error is found in this manipulation and in the subsequent one of letting it open, it is wound again, and pushed into a wire ring, the size of which corresponds to the diameter of the barrel.

The springs are in this condition again subjected to a closer scrutiny, and are then sent to the packing room, in which the work is principally performed by girls, and each spring is first calibrated according to height and diameter. They are next placed, one dozen each, between brown paper, and then packed between two small pieces of card-board and provided with labels.

In another workshop we see a number of stamping presses, with which the springs are perforated, and a number of small pieces of very varying shape are stamped out of the strips of spring. They go to the United States, and are used for the different systems of spring fastening in vogue there.

The manufacture of clock springs is essentially the same in its details, but, for self-apparent reasons, the same degree of skill is not required in their treatment.

The smallest springs belonging to this series are the musical-box springs, as well as those for alarm, mantel, and other clocks. They are all treated in about the same manner as the watch springs.

It is different, however, with the larger sorts of springs for French, Vienna and Black Forest clocks, as well as the closely-wound American springs and those for telegraphs. These sorts are treated in broad, long ribbons, placing them in a rolled-up condition, while keeping their single coils apart by means of wavy steel ribbon, into the furnace, after which they are tempered. The entire ribbon is then, by the use of a large furnace and a pressure of from 100 to 200 pounds, straightened and annealed. The spring receives its appropriate temper and elasticity thereby.

The ribbons are next placed in the polishing machine, and each two polished at one time. They pass through two rotating wheels, situated within a receptacle filled with emery and oil, and next pass through a cleaning box containing sawdust, whence they issue perfectly bright, after which they arrive to the rolling-up apparatus.

This work was formerly accounted to be one of the severest in the entire manufacture, since the ribbons had to be drawn to and fro by hand, until perfectly white, between the polishing wheels, while the present method of working taxes the muscular power of the workman only very slightly. The machinery requires three horse-power.

The flat sides having been handsomely polished, the ribbons are cut into strips of prescribed breadth. The small strips are then treated upon a rounding machine constructed for the purpose. It consists of a horizontally-revolving emery wheel and a continuously-working apparatus for rounding off the edges. The saving of labor against the old method is as 1:5—since the springs, of a length of $1\frac{1}{2}$ meters, had formerly to be treated by hand upon its flat sides as well as upon its edges—a process still in use in the French and Swiss factories.

When the spring has been nicely polished and rounded, it is cut off in appropriate lengths; both ends are glowd and punched. These ends are then again polished upon the machine, and the springs are finally placed either upon a gas or a coal furnace, for imparting color, according to thickness.

The remaining treatment is similar to that described for watch springs, with the exception that larger tools are used for the purpose.

The power of a spring, which to a certain degree is a matter of guess work, is ascertained as follows: A spring winder is located upon an inclined plane; the spring is slowly wound with the former, and when wound to one-third of its length, a weight of from 10 to 50 kilograms (1 kilog. = 2.205 pounds), is suspended at its outer end. If, now, the spring raises this weight, at the eighth or tenth turn, in such a manner that its different coils do not fold closely together above, it is said that the spring possesses a power of so many kilog. lift per second.

The so-called machinery watchwork springs are the largest sized ones, and are at once cut in their required breadth, tempered and elaborated as above described.

In proportion to their increasing strength they demand more care than the weaker sorts, until they are wound into a certain ring or diameter.

The factory of Eberle & Co. also manufactured the spring for Thomas' infernal machine. It was ordered by a firm in Leipzig, and had a diameter of 110 mm., breadth of 60 mm., thickness of 0.3 mm., and was 5 meters long. In its wound condition it developed about 150 kilog. power.

The instrument maker, Mr. Fuchs, of Bernburg, who made the mechanism, without suspecting its real purpose, has meanwhile used about 100 such springs for museums and exhibitions.

The largest spring manufactured at this place was for Southern Russia; it was 80 millimeters broad, 280 mm. diameter, and 1.6 mm. thick; its length was 17 meters, and its power 165 kilograms. The price of such a spring is 120 marks (about \$30).

A firm in Hamburg ordered springs 2 mm. thick, 130 mm. broad, and 25 meters long. The power of each was about 500 kg., and its price 300 marks.

It is seldom, perhaps, that the establishing of a factory has had to contend with greater difficulties than this one, because so many material dealers imagined that a good spring could be produced only out of the country.

It was of vital interest to render French competition impossible, which was done in the years 1870 and 1871. The Swiss spring factories, engaging only from five to twenty workmen, could not even approximately supply the demand, while the factory of Eberle & Co. was already excellently organized, and capable of turning out about 600 dozen of watch springs per week. The factory has lately been materially enlarged, and occupies about 210 workmen, 100 of whom are exclusively engaged in manufacturing watch springs. The factory turns out at present 4,000 dozen of the latter, and 6,000 pairs for mantel clocks per month, thus having excelled all its foreign competitors, and standing without a rival in the German Empire.

I was sorry to see two things which I deeply deplored. First, no rational method is adhered to in the calibring of the springs. The intelligent owners of the factory would willingly adopt some reasonable standard gauge, but of course they are forced to comply with the demands of the material dealers, who obstinately adhere to the gauge of Robert, Montagnon, and other antiquated horologists, and it will be long until a more rational standard will be adopted.

The second was that the excellent product has to be provided with French or English labels, thus giving it the appearance of a foreign article. Also, this is demanded by the middlemen, and is so closely adhered to that even the watchmakers of the very place do not know that springs for fine watches are manufactured in their immediate vicinity.

* * * * *

Repairing Watch Cases.

[By W. SCHWANATUS, Berlin, Prussia, in *Deutsche Uhrm. Zeitung.*]

Continued from page 321.

NEW JOINTS FOR THE DUST CAP.

THIS JOB becomes occasionally necessary for silver cases. When it occurs, file the hinges entirely away with a hinge file, and when sufficiently deep, finish with a fine round file; next spring the dust cap upon the edge and see whether there is sufficient room for the new hinges. Now take hinge wire of the size of the previous hinge, or else be guided by the size of the brass hinge still on the dust cap, nip off a piece of the entire length of the old hinge, and secure it with binding wire, paying strict attention, when doing it, that the joint is turned exactly downward. Also pay attention that you do not make the new hinge any longer than the old one has been, since it might easily happen that the ends of the hinges would lie against the bottom rim, whereby this cannot close at that place. We casemakers do not bind on the entire hinge, but divide it at once into two parts, bind on each part separately, and only leave as much free room as is necessary for the dust cap hinge. The first method is easier for the watchmaker, however. When the hinge has been soldered in place, pickle the middle piece and file out the hinge, that is, fit in the dust cap hinge into the soldered-on hinge, by filing this out. When done, the soldered-on hinge must with a broach be opened as much as that of the dust cap, after which the middle part is ground and polished, and the case is put together again.

It happens sometimes that the hinges on the middle piece are still in a state of good preservation, while that on the dust cap has either been damaged by overstraining, or been broken off on account of bad soldering. When this occurs on a brass dust cap with soldered hinge, the watchmaker may undertake the repairs himself, but should it be a silver or gold one, I would advise him not to undertake it, since the execution of this job, as the dust cap has to be nicely polished again, is connected with difficulties, and and, beside this, it is not without risk. If he wishes to solder the still well-conditioned broken-off hinge of a brass dust cap in place again, secure it with binding wire, its joints downward, binding it right firmly upon the place it has occupied, anoint the entire dust cap with well-ground borax, also put a little on the hinge to be soldered, then a little solder, and solder in the customary manner. It is well to drive a pretty strong iron wire in the coal, and to lay the dust cap firmly against it to keep it from falling off during the act of soldering. The preliminary moistening of the dust cap with borax, within as well as without, is done for the purpose of preserving its graining during soldering. If this soldering is to satisfaction, pickle the dust cap and broach the hinge. In case the old hinge should no longer be fit for use, and you are obliged to make a new one, of course make one of the same thickness of metal; remove also all remains of the old hinge with a round file, which, however, perform with all necessary attention, and do not file too much.

As is well known, the hinge of the dust cap in cheap watches is riveted in place, and it occurs frequently that such a hinge has become loose. In order to fasten it again, the majority of watchmakers, as well as casemakers, drive in new rivets, a process, however, which I cannot recommend, since hammering and filing the dust cap becomes necessary. The metal of the latter is generally very soft, and the consequence is that the place at the dust cap generally becomes raised by these violent means. The gilding of the dust cap also suffers by the filing and smoothing down of the riveting. The following method is far more expeditious, and the cap is preserved intact. If the hinge has become loose from the rivets, take out the hinge pin, and press the hinge firm into the rivets still within the dust cap. For sake of caution, the latter may also be laid upon a flat case stake, and impart a few careful taps upon the rivets with a small hammer. Then supply a little soldering fluid to the hinge with a fine wire, but very little, so that it cannot draw into the dust cap, place a small piece of tin from outside upon the extreme edge of the joint, introduce the dust cap into only a moderate flame, and let the tin flow between it and the hinge. The latter will obtain more solidity, and remain cleaner in this manner, than by the insertion of new rivets. If the job has been done carefully, nothing will be visible of the tin soldering, and the main thing is to preserve the gilding intact.

[The preceding article ends Chapter I., and in the next one the author enters into gold and silver plating. Since there are as many methods for doing this as there are gold and silver platers, and since, beside this, the subject has been repeatedly explained and discussed in the columns of THE CIRCULAR, we bring the article to a close.]

Gilding Watch Parts According to the Swiss Method.

[By OTTO BEHREND in *Deutsche Uhrmacherzeitung.*]

Continued from Page 334.

The following compositions of baths are used the most:

I.

Water.....1½ kilograms (3.307 pounds).*
Cyanide of potash.....45 grams (1 oz., 8 dwts., 22½ gr.)
Gold oxide-ammoniac..... 8 grams (5 dwts., 3.46 gr.)

II.

Water.....1½ kg. (3.307 pounds).
Cyanide of potash.....25 gr. (16 dwts., 1.8 gr.)
Gold Chloride..... 5 gr. (3 dwts., 5.16 gr.)

III.

Water.....1 kg. (2.205 pounds).
Cyanide of potash.....49 gr. (1 oz., 5 dwts., 17.3 gr.)
Chloride of gold.... 10 gr. (6 dwts., 10.32 gr.)
Ammoniac..... 2 gr. (1 dwt., 6.86 gr.)

IV.

Water.....5 kg. (11.023 pounds).
Ferrocyanide of potash.....100 gr. (3 ozs., 4 dwts., 7.2 gr.)
Purified carbonate of potash.... 75 gr. (2 ozs., 8 dwts., 5.18 gr.)
Sal ammoniac..... 15 gr. (9 dwts., 15.49 gr.)
Chloride of gold..... 8 gr. (5 dwts., 3.46 gr.)

The salts are dissolved in boiling water, the fluid is filtered, and the chloride of gold is then added by constant stirring.

For the above baths, the quantity of the water may be augmented or decreased at option, whereby a quicker or a slower gilding is effected. As previously mentioned, they have been tested and found useful.

A bath for wheels, which are to have the appearance of composition, or red gold wheels, is prepared by adding to an old or a fresh bath either a little sulphate of copper (copper vitriol), or acetate of copper (crystalized verdigris), and sufficient cyanide of potash solution, until the blue color has entirely disappeared.

*All these recipes are weighed like metals.

The greater the quantity of these salts added, the redder becomes the color. Should too much have been added, the bath may be made paler by adding a little of the silver bath described below, or else a little chloride of silver.

For the use of this copper bath, a stronger current is necessary than for the gold bath.

The wheels, as above mentioned, must be perfectly polished before immersing them in the bath, and they are subsequently re-polished with the sword file, to restore their high luster.

SILVERING BATH.

Water.....2½ kg. (5.512 pounds).
Chloride of silver.....25 gr. (16 dwts., 1.8 gr.)
Cyanide of Potash.....70 gr. (2 ozs., 5 dwts., 0.2 gr.)

Metalic silver is dissolved in nitric acid, precipitated by a few drops of hydrochloric acid, and added to the water in which the cyanide of potash has been dissolved. In its place, also, nitrate of silver may be added to the water, in which it dissolves at once and forms a strong precipitate. It re-dissolves by stirring, and the bath becomes as clear as water.

Green gilding is produced by adding a little chloride of silver to the ordinary gold bath, or a little of the previously described silver bath.

The ready baths may be preserved in well cleaned bottles, well closed with glass stoppers. When to be used, the necessary quantity is poured in porcelain or well glazed faience vessels, in which the conduit wires of the battery lead.

[THE END].

[From Our Special Correspondent.]

The National Exposition at Zurich.

Mr. Editor:—The exposition is about drawing to an end, and your correspondent is in duty bound to say that it has most worthily been undertaken, sustained, and is about being brought to an honorable closing. Switzerland is well entitled to the honor of speaking of its exhibition in terms of pride.

A few additional awards were made, and I complete the list of my last letter by adding the following recipients:

a. HORLOGERIE DE PRECISION.

F. Bronn; C. Degallier; J. E. Dufour & Cie.; H. R. Ekegren; A. Golay-Leresche & fils; L. Gostkowski; F. Monard; Patek, Philippe & Cie.; A. Pavid; H. F. Piguet; Fritz Piguet & Bachmann; H. Redard & fils; J. Rossel fils; Gustave Sandoz; C. L. Weidemann; Zentler frères.

MATERIALS AND DETACHED PIECES.

1. Oils—Fr. Piguet fils; Caspari Aug. Avenches.
2. Cases—Franc. Borgel.
3. Blank Works—Husson & Retor; V. Piguet & frères; A. Rannaz.
4. Detached Pieces—E. Balland & Cie. (stems and push buttons); J. Bastard & Redard (crystals); E. Berlie (mainsprings); Claude Collonnaz (anchor escapements); Cornioly fils (springs); Em. Cottier, of Carouge (medalions); C. H. Crausaz (compensated balances); J. Darier & Cie. (hands); Marc Gay (keys); Ed. Golay (compensated balances); A. Goy & Blanc (anchor escapements); A. Hillgrèn (balance springs); E. Klein (mainsprings); V. Leisenheimer & fils (hands); Moré & Méroz (dials); C. A. Paillard (palladium springs); P. Perrenod (anchor escapements); A. Piguet & fils (stamped pieces); P. Reymond (dials); Wagnon frères (hands).

Watchmakers' and Goldsmiths' Brushes—Tschumi, J. J., Geneva.

Haist, Rodolphe, Chaux-de-Fonds, for the excellence of his corundum powder and watch rubies.

Some time last year you published a "Stroll through a Swiss Balance Spring Factory," and we were pleased to meet with the gentlemen, Bahni Bros., of Biel, through whose establishment we were shown,

and who exhibit within their showcase everything worthy of notice in the manufacture of such springs. From the crude steel to the ready spring, all kinds of springs can be seen—the flat, the cylindrical, and the spherical. Their goods produce a lively interest in even non-horologists, and every one stops to examine and observe the functions of the balance spring. The owners exhibit a large balance, which is actuated by the spring, and it is one of the chief attractions of the place. They kindly furnished me with the following statistics as to the number of springs produced in their factory:

1876.....	10,676 gross =	1,534,608 pieces.
1877.....	11,015 " =	1,586,160 "
1878.....	12,156 " =	1,750,464 "
1879.....	14,930 " =	2,149,920 "
1880.....	19,221 " =	2,767,824 "
1881.....	20,537 " =	2,957,328 "
1882.....	22,970 " =	3,307,680 "

Total in 7 years... 111,486 gross = 16,053,984 pieces.

When placed end to end, these balance springs would span about one-eighth part of the globe. The factory does not alone furnish springs for fine watches, but also for the more current articles, clocks, gauges, aneroid-barometers, etc.

We pass by various show cases with jewels, material, utensils, and all the horological odds and ends, and join the crowd standing before the *vitrine* of an exhibitor who verily and firmly believes that his patented timepiece will eventually supersede all other devices in the shape of watch winding. This modest inventor is no less than the Knight von Löhr, whose peculiar system was duly mentioned in your *JEWELERS' CIRCULAR* several years ago. The watch is wound by the jar produced in walking—in fact, it is the same arrangement as that used for the pedometer; a finely-toothed ratchet wheel is set in motion, whereby the winding of the watch is effected.

Watches, watches everywhere, and I therefore do not pause to examine the cases, but wend my way over to the electric clocks of Dr. Hipp, who, I believe, received a medal also at the Philadelphia Centennial. I am so free as to borrow the description, written by an expert pen, from the Geneva horological periodical, *Journal Suisse d'Horlogerie*, which, by the way, is an excellent publication. The correspondent says as follows: "Mr. Favarger, an engineer of the establishment, gave me the following data: A notable piece of Hipp's exposition is an astronomical regulator, which is actuated by electricity, and whose mercury-compensated pendulum oscillates under an unvarying barometric pressure.

"It is a well established fact that the rate of a regulator is influenced not alone by the variation of temperature, but also by those of the density of the air, also called barometric variations.

"According to the experiences of Dr. Hipp, an increase in the atmospheric pressure of 1 millimeter corresponds to a retard of the 93-10,000th part of a second in the daily rate of a seconds pendulum; it would become necessary, therefore, to accompany the precision pendulum with a pressure device, acting in the same manner as the temperature compensators. Since, however, the making of auxiliaries necessary for the correction of such infinitesimal quantities is naturally very difficult, it was thought preferable to avoid this difficulty by withdrawing the regulator from the influence of the barometrical variations, and protecting it against the atmospheric air. Mr. Hipp has effected this isolation by means of a cylindrical glass bell, closed at its two ends by two plates provided with india-rubber rings, the upper one of which carries the different portions constituting the regulator, while the lower one is furnished with a stopcock, whereby the interior of the bell may be connected with an air pump.

"That the motion of the pendulum is sustained by electricity becomes of vital importance, since by its help the regulator can be isolated; it might be supposed that it would be necessary to wind up the actuating weights or spring every day, or every eight days; this could be done only by exposing the mechanism for that length of

time to the influence of the atmosphere. But by employing electricity, we have a motor which is perfectly independent from the regulator itself, and which may be sustained without producing any change whatever, either upon the motion of the pendulum or upon the condition of the always uniform density of air in which it moves.

"In order to make his regulator a veritable timepiece *de precision*, Mr. Hipp constructed the movement in such a manner that he dispensed as much as possible with the various frictions found in ordinary timepieces, which are liable to occasion greater variations of rate than those due to the pressure of the air, and which would render vain all the precautions taken, as specified in the preceding. He succeeded in dispensing with depths, pivots, and oils; his pendulum oscillates as freely as possible, and is disencumbered of all other functions except the one properly belonging to it, viz., that of governing the arrangement sustaining its motion (electric escapement), and emitting currents every second, which actuate the dummy clocks connected with it. These two mechanisms, one of which sustains the motion of the pendulum, while the other propels the dummy clocks, are constructed in such a manner that they require only a minimum of the moving power of the pendulum; they are set into action by a very simple device, whereby friction is reduced to an exceedingly trifling quantity."

It is unnecessary to mention various other mechanisms, pertaining to all branches of the electric department, constructed by Dr. Hipp. As this gentleman is quite a successful inventor and indefatigable worker, and enjoys a world's fame, he is doubtless as well known to your readers in America as he is here in Europe. The world has need of such men.

The random notes of this and the preceding letters, Mr. Editor, comprise about everything notable and interesting to your American readers. Let it not be said by this, that I have mentioned *everything* of interest. Far from it. But I have purposely abstained from tiring the interest of your readers by specifying everything to be seen at this truly great Swiss exhibition, and I have purposely only mentioned the names of those who really endeavored to contribute with their goods to enhance the beauty of the exhibition, and who therefore were worthy of a special mention for their laudable efforts and products.

Hoping that my jottings have contributed to interest one or the other of your subscribers, I sign myself
JAN.
ZURICH, Sept. 28, 1883.

Watch Manufacture in England.

[From the London *Times*.]

THE SUMMARY recently given by the *Times*' Geneva correspondent of the progress of the watch trade in Switzerland may be usefully followed by some account of the present position of the same industry in England. The extent of the English watch trade is broadly indicated by the watch cases marked at Goldsmith's Hall and the assay offices at Birmingham and Chester. A deduction has to be made for cases and movements of foreign origin, but some materials for this discrimination are available. In 1880, the latest year for which complete returns have been published, the total number of watches hall-marked was 206,000. The proportion of foreign cases and of foreign movements cased in England, included in these returns, cannot be estimated at less than 25,000. At Chester, where a distinguishing record has been kept, the foreign cases have averaged 13,000 per annum. Making the allowance required by these considerations, the total annual production of watches in England cannot be estimated at more than 180,000. If we contrast with this the fact that in 1796 191,700 watches were marked in Goldsmith's Hall alone (complete returns for the whole country cannot now be obtained), it will be seen that the industry, viewed relatively to increase of population and general commercial expansion, has been suffering from distinct atrophy.

Side by side with this fact must be noted the creation of the American watch trade, which, within 30 years, has probably attained three times the proportions of the English trade; the growth of Besançon, which has placed France among the most important watch-producing nations; and the immense development of the art in Switzerland. The English trade has now no pretensions to occupying the home market. English watch manufacturers find their most profitable business in the colonies; 100 years ago they probably did not export 5 per cent. of their goods; the proportion is now about 50 per cent. At the same time the demand for watches at home has by no means slackened, but has kept pace with our national prosperity. This demand has been met and stimulated by the foreigner, and above all, by the Swiss, who are the great makers of watches for the million, and therefore the great makers of cheap watches. The tendency in the price of English watches is nevertheless downwards. Since 1870 the form in which the trade returns have been recorded does not admit of a comparison on this head, but the figures of previous years show that the average price of English watches exported fell from £6.76 in 1867 to £4.76 in 1870. There is no reason to believe that this tendency has been arrested, and on its development the future of the English watch trade largely depends. This condition is not inconsistent with the production of high-priced watches of superior quality; but it requires that the wants of unambitious buyers shall also be met. In this field foreign manufacturers, and notably the Swiss, have a practical monopoly: During the past five years our total importation of foreign watches (excluding foreign imports re-exported) has fluctuated between £400,000 and £500,000. In 1867 the import was only £186,000. Taking the four years from 1867 to 1870—data for a later survey are wanting—Mr. Edward Rigg, of the Royal Mint, has shown that the mean price of foreign watches imported for English consumption was £1.60; the average price of foreign watches re-exported was £2.86. The latter estimate compares most fitly with the average price of the exported English watch, which, for the same period, has been calculated at £5.41. English manufacturers would do well to consider whether this marked difference in price is justified by a corresponding difference in quality.

The causes that retard the development of English watchmaking may be traced to defective organization and defective appliances. The method of manufacture and the tools employed are not substantially different from the method and the tools of 100 years ago. It is a natural consequence that the trade has shown no elasticity, and that in latter years it has found little custom at home. English watches are not made in sufficient quantities to justify the production on a large scale of any one particular type; the trade is for the most part in the hands of "small men," who make certain sizes in dozens and half-dozens. In the Swiss and American factories a particular type, if it be considered worth making, is made by thousands; everything is organized for production on a large scale. Confining the contrast to English and American methods, the principal point upon which it is necessary to insist is that in America the 12 or 14 trades which constitute watchmaking are aggregated under one roof and form one compact organization. By the older method still pursued in England, and until recently almost the rule in Switzerland, the different parts are transported from one workshop to another in different quarters of the town, and even from one part of the country to another. Under the new method the *maximum* of efficiency and individual responsibility is obtained by the minute subdivision of every process; the loss of time in the transfer from one department to another is so minimized as to be practically non-existent. In the United States one company alone employs a capital of £400,000, and with 2,300 hands produces 200,000 watches annually—an output equal to the entire English trade. There are no official returns of Swiss manufacture, but the best authorities estimate its growth during the past five years at 1,000,000 watches, the total standing to-day at 3,500,000. Besançon, the center of the French trade, shows an equally remarkable progress. During the

five years 1845-9, the average annual production of watches in France was 47,800; it now exceeds half a million. About 90 per cent. of the watches made in France come from Besançon.

It may be taken that an expenditure of £50,000 is scarcely sufficient to aggregate the different branches of watchmaking under one roof, and to supply the new and improved appliances which, during the last 50 years, have been brought to bear upon the art. It would be mockery to tell a small and struggling tradesman that he must organize his business and make a hundred watches instead of one; combination is the only conceivable means by which, in the majority of cases, so radical a change could be effected. To this solution the jealousies and isolation of small manufacturers, their conservative instincts and love of independence, present obstacles that may be regarded as practically insurmountable. In the United States the capital required for associated enterprise has been easily found, because the field had not been previously occupied, and no trade traditions stood in the way.

If this were the conclusion of the whole matter, the prospect would be hopeless indeed. Fortunately, efforts are being made in England to cope with the situation. A plant of machinery for the manufacture of the keyless type of watch has in recent years been established in London; an American plant has been put down in Birmingham for the production of both key-winding and keyless watches; a second firm in Birmingham is working an organization for the production of the ordinary English watch in demand in the colonies; and in Coventry modern treatment has been grafted on an old-established business, and is working side by side with old methods of manufacture. The financial results of such new enterprises may not at first be wholly satisfactory. In American watchmaking much money has been lost; out of a dozen companies four only can be considered prosperous, while, so far as the original shareholders are concerned, several companies have ceased to exist. The experience thus gained, though not directly profitable to those who have borne the cost, has added to the general stock of knowledge; and putting aside special impediments, the chief of which may be said to be the existence of a large number of manufacturers with limited means, the necessary transition might be accomplished in this country in much more favorable circumstances than attended the planting of the industry in the United States.

American Gems and Precious Stones.

A Paper presented to the United States Geological Survey by George F. Kunz.

PRECIOUS STONES.

Domestic production.—Although so many varieties of gem stones are known to occur in the United States, many of which afford fine specimens, while a few valuable stones are exclusively indigenous, the annual output is still very small in comparison with the prospective extent of the field. It is impossible to obtain exact statistics of the product, but an extensive correspondence with experts and dealers justifies an estimate of between \$50,000 and \$60,000 as the sales in 1882 of cut gem stones of domestic production, exclusive of the gold quartz souvenirs, which should be credited to precious metal mining. The value of the stones before cutting was much less—probably little above \$10,000, as about four-fifths of the market value of the stones represents the enhancement due to cutting. This applies more strictly to the common gem stones; and in the case of agates and moss-agates the value of the uncut stones is often not one per cent. of the price of the gems after cutting. The amount stated as the value of uncut stones is of those sold to be cut; besides which, as shown in the accompanying paper by Mr. Kunz, there are sales of small amounts, to tourists and collectors, of stones which are valued merely as specimens, and which do not reach the gem market.

Few persons are familiar with the appearance of gem stones in their native state; so that while quartz pebbles are often mistaken for rough diamonds, garnets for rubies, illmenite for black diamonds, etc., on the other hand it is quite probable that many valuable occurrences have escaped notice. The competition of the cheap foreign cutting is also a disadvantageous factor.

Imports and re exports.—The following tables show the values of foreign stones imported and re-exported during a series of years. They probably include small quantities of American stones, as these are sometimes cut in Europe and thus lose their identity.

Precious Stones imported into the United States during the fiscal years specified (specie values).

	[Dutiable.]	Values.
1872.....		\$3,053,595
1873.....		2,870,690
1874.....		2,274,790
1875.....		3,399,593
1876.....		2,480,214
1877.....		2,114,704
1878.....		2,975,512
1879 ..		3,842,007
1880.....		6,698,488
1881.....		8,332,511
1882.....		8,444,525
Calendar year 1882.....		8,154,397

Precious Stones of foreign production exported from the United States during the fiscal years specified.

1872.....	\$34,438
1873.....	9,393
1874.....	102,932
1875.....	185,231
1876.....	79,631
1877.....	51,730
1878.....	15,569
1879.....	5,785
1880.....	7,605
1881.....	64,256
1882.....	85,001
Calendar year 1882.....	93,537

An annual importation of \$8,000,000 worth of precious stones (to say nothing of the considerable quantities smuggled, which escape the record), shows that this country is an exceptionally heavy purchaser—as would be supposed even in the absence of statistics. The imports vary greatly in different periods and are largely determined, as may be seen by a comparison of the years cited, by changes in the general prosperity or by speculative profits. The new tariff law fixes the duty on precious stones of all kinds at 10 per centum ad valorem.

AMERICAN GEMS AND PRECIOUS STONES.*

BY GEO. F. KUNZ.

In the United States, systematic mining for gems and precious stones is being carried on at only two places, viz., Paris, Maine, and Stony Point, North Carolina. In other cases where gems are found they are either met with accidentally, or occur in connection with other materials that are being mined, or in small veins which are only occasionally met with. They are often gathered with little system on the surface, as is the case with the sapphire, garnet, and olivine found in Montana and New Mexico; or from the beds of streams and decomposing rock, as the moss-agate from Colorado; or on beaches, as the agate, chlorastrolite and thomsonite from Lake Superior.

Nearly all the gems found in these ways are sent to the large cities in small parcels, or are sold at the localities to tourists, or are sent to other localities to be sold as having been found in the

*This paper is the result of an application by Mr. Williams to Messrs. Tiffany & Co., of New York City, for the purpose of obtaining certain facts relative to the gems and precious stones of the United States. I may here state that whatever information is presented is due to the usual courtesy and generosity of that firm, whenever they can assist in advancing science or art, in placing at my disposal not only all the facts and material at their command, but also the time required by me in collecting whatever other existing data there might be relative to this subject. In view of the little that has been published and the paucity of reliable facts, it is hoped that the deficiencies in this article may be overlooked.—G. F. K.

vicinity. Many of the gems are known only locally, some to mineralogists only, and others that are mentioned here are known only to a certain few who constitute the gem collectors of the United States, and whose one object is to find something that possesses the qualities of a gem or precious stone, for the purpose of enriching their cabinets; still, a list of this kind will be of interest and value to the mineralogist and to the many others who may have never known of their existence in this country, to whom this knowledge may have a commercial value, should some of these minerals be met with in sufficient quantities and of good quality; it may also direct attention to what has a value and has not heretofore been utilized. Wherever a gem is mentioned from the sale of which a small amount has been realized, it is mentioned merely to note its occurrence in this country, whereas in other countries the gem is often found of better quality and in larger quantities. A list is added of the principal gems that have not been found in this country, and also a list of those that have not been found elsewhere.

We know that the mound builders have worked the turquoise mines of New Mexico, that they have made arrow and spear points of rock crystal, smoky quartz, and obsidian, and that they have buried crystals of quartz with their dead; that the fluorite of Hardin county, Illinois, was by them worked into ornaments, and that some of the most beautiful agatized and opalized woods, agates, jaspers, and obsidian were by them worked into arrow-points, and now after a long time are mounted as ornaments by the white man, the precious stones thus serving a double purpose.

Diamonds.—Diamonds have been occasionally found at a number of localities in the United States, but as yet at no place has more than an occasional crystal occurred, never enough to warrant any extended mining for them. The diamond found at Manchester, opposite Richmond, Virginia, weighing after it was cut over 10 karats, is worthy of mention. An occasional stone has also been found at the Portis mine, North Carolina, Hall county, Georgia,† and with platinum in Oregon. They are also reported from Idaho, San Juan county, Colorado, and from Cherokee Flat and several other localities in Butte county, California. A beautiful crystal that cut a remarkably fine three-eighths karat stone was found near San Francisco. Two crystals weighing over 2 karats each are on exhibition at a jeweler's in Indianapolis, and are said to have been found in Indiana. Within the past year a diamond is reported to have been found in Missouri by a hunter who was stopping to take a drink of water at a small brook. This diamond weighs 2½ karats, and by some experienced judges is pronounced of Brazilian origin, so that the occurrence is somewhat doubtful.

Many experienced geologists hold to the opinion that so many of the associations of the diamond are present in North Carolina that they have hopes of their being found there. The garnet districts of Arizona and New Mexico may also be looked upon as favorable for the occurrence of this gem.

No estimate can be put on the annual amount found. Many reported finds of diamonds of large value in the newspapers are either myths or are based on the finding of rock crystal or even glass, and a diamond value is attached, as in the case of the Missouri diamond mentioned above. It would be possible for diamonds to occur and be for a long time overlooked in a district inhabited or frequented by no one who really knows the diamond in its rough state, whereas rock crystal is often mistaken for diamond.

[Mr. John H. Tyler, Sr., of Richmond, Va., furnishes the following account of the large diamond found at Manchester:

"This diamond was found in Manchester, Chesterfield county, just opposite Richmond, by a laborer engaged in grading one of the streets. It was brought to me to ascertain its character and value. I pronounced it at once a very valuable diamond, and recommended the finder to keep it carefully and to see me again about it. I did not know his name, and have not seen him since. The next I heard of this stone it was on exhibition at Ball, Black & Co.'s store in

New York, and that it had been sold by the finder to some one in New York for \$1,800, though I could have got for him \$5,000 for it. I understand that it was sent to Germany to be cut. It was an octohedron, and had had only one small black spot near one of the points, thus enabling it to be cut to great advantage. I was the first to examine and pronounce upon it."]

Sapphires and rubies—Sapphires and rubies have been found at Vernon, New Jersey, but always more or less opaque, and although a number have been cut from this locality, the probability is that there has not been a single gem.

At the Jenks mine, Franklin, Macon county, North Carolina, where corundum mining was being carried on some years ago and has recently been resumed, the mineral being mined for use as a grinding and polishing substance, fully fifty gems were found, some of them weighing two karats. Only about one-half of these were of good color, most of which were really gems in every sense of the word.‡ The colors were rich blue, violet blue, ruby red, light red, pink and yellow; and others were colorless. No one of these gems had a higher value than possibly \$100. The smaller ones were the richest in color.

The principal locality for sapphires in the United States is in the garnet districts near Helena, Montana; Santa Fé, New Mexico; southern Colorado and Arizona. Here they occur in the sand, associated with peridot, pyrope and almandine garnet. From this district they are sent to the cities in odd lots, as they happen to be met with, and no regular searching for them is carried on. They are often found with the associated gems on ant-hills, which abound in this district. Two gems § from here may be mentioned, although weighing only one-eighth of a karat each, one of which was a true ruby red, and the other a sapphire blue, colors rarely met with. The gems are usually of a light green, greenish blue, light blue, bluish red, light red and red; also, of all the intermediate shades. They are usually dichroic, and often blue in one direction and red in another, or when viewed through the length of the crystal, and frequently all the colors mentioned will assume a red or reddish tinge by artificial light. A very interesting piece of jewelry || was made of these stones in the form of a crescent; at one end the stones were red, shaded to a bluish red in the center and blue at the other end; by artificial light the color of all turned red. Perfect gems of from four to six karats each are frequently met with. Occasionally crystals are found which would afford ruby and sapphire asterias of a poor quality.

The value of the gems that are cut of material found in this district amounts to fully \$2,000 per annum. There are, however, a great many found that are never cut, owing to the higher cost of cutting, and the greater skill required in cutting this gem.

Spinel.—Spinel has been only occasionally met with in gem form in the United States. From the locality near Hamburg, Sussex county, New Jersey, may be mentioned specimens of a smoky-blue, a velvety-green, and a dark-tinted claret color; they are all very good gems and weigh about two karats each.* Some half-dozen very fine ones from San Luis Obispo, California, of very good quality and weighing about two karats each, are also worthy of note.†

Topaz.—Topazes have been found in Arizona, New Mexico, and occasionally in southern Colorado. Those from the last named locality are of a beautiful light-blue color, and one ‡ of them weighed over 30 karats. They have also been found at Pike's Peak, § Colorado, and more recently at Stoneham, || Maine. At both

‡ Collection of Dr. Jos. Leidy.

§ Collection of G. F. Kunz.

|| Collection of Tiffany & Co.

* Collection of Rev. Alfred Free.

† Collection of James W. Beath.

‡ Collection of Tiffany & Co.

§ *American Journal of Science*, October, 1882.

|| *American Journal of Science*, III., XLV., No. 146, p. 161; and New York Academy of Sciences, November 7, 1882.

† *American Journal of Science*, II., ii., 253, and xv., 373.

the last named localities they occur in large crystals, but if cut into gems would afford only small stones of little value. The color of the Pike's Peak topaz is light blue, and it is quite clear. The price of such stones is regulated by the color, perfection and size. The supply yields less than \$100 a year at present; but it is probable that this amount will be increased in the near future by the Pike's Peak production.

Beryl, emerald, aquamarine.—Emerald has been found at Stony Point,* Alexander county, North Carolina, in crystals, some from eight to ten inches in length associated with hiddenite, rutile and garnet. The crystals as a rule have a white core, and although as mineral specimens they are grand, yet few gems have been found up to the present time, and these of second grade. Future developments may, however, bring some fine gems to light. Beryl, spodumene, and the associated minerals have been found on the Lyons property, adjoining that of the Emerald and Hiddenite Mining Company.

Aquamarine has been found at a number of localities in America, the principal among them being Royalston, Massachusetts; Actworth, New Hampshire; Grafton, Vermont; Burke county and Stony Point, North Carolina; Paris, Maine; Fitchburg, Massachusetts; and Avondale, Pennsylvania. The richest known gems from any known locality have been found at Royalston,† Massachusetts, and although small are almost as blue as the sapphire. Large clear gems of a light-blue and sea-green tint have been found at Actworth, Grafton and Stony Point, at the latter locality shading into the beryl-emerald. At Stoneham, Maine, two fine crystals have been found in a pasture; one of which will furnish a fine blue gem over 20 karats in weight. The crystal, of which only one-half was found, is 5 inches long and 1 inch across; it is equal in color to any from Siberia, but has been badly broken by frost or by the hand of some one who was ignorant of its value.

The entire amount of beryl gems found in the United States in the last ten years would not bring over \$2,000, and they are scarcely known to others than collectors.

(To be Continued.)

Artistic Oddities.

"The customers who visit us most frequently," remarked a dealer in bric-à-brac, "are those who have a passion for the quaint and odd in art playthings. We are careful to call their attention at once to any oddity we may pick up. Each of them seems to infer that he alone has had a sight of it, and if we can show that it is as unique as it is odd, we do not have to wait long for a customer."

"Do you often meet with articles which are really unique?"

"No, we do not. Practically, in this business, an article is unique when, the demand for it not being large, we do not often run across it. People often believe, if they have a bronze article differing in some striking point from others of the sort, that it is the only one of its kind. They do not know that elastic moulds are used for certain kinds of quaint bric-à-brac. The maker casts his first figure as the mould stands; then by altering the mould slightly after each cast he produces a large variety of figures. Some makers do not use changeable moulds, but cast large numbers of their specialties and ship them to various points in assorted lots, not permitting more than a dozen of a kind to go to any particular place. This is the sort of stuff that admirers of the odd pay considerable prices for.

"A man showed me one of these quaint and so-called ancient bronzes the other day, for which he had paid \$250. The subject was 'The Morning Bath,' and the bronze was signed 'Roma, P. fec.' It purported to have been dug up in the Campagna. Incrustations

of soil were to be seen here and there; the metal was oxidized in places, and verdigris lent its aid to the effect. But the design was of to-day, the soil was of New York origin, and the green tints and oxidations were artificially produced. The 'odd' characteristic of this little bronze was the fact that a boy in the piece had the legs of a satyr. Otherwise the piece would have been a wholesome piece of design, a quality which would have ruined it for searchers of the queer in art.

"Do I consider the taste for oddities a healthy one? Not when it is carried as far as it is by those who make it a specialty. I had a customer once whose taste in art was ruined by his fancy in this direction. I had placed in my window a very curious old print of Abraham and Isaac. On account of a slip of the engraver's burin, Abraham's nose was so enormously large as to interfere with the solemn nature of his intentions touching his son. The young man I speak of was fascinated by this picture. I held it at a prohibitory price, \$75. He determined to buy the print, and deposited \$25 on it, begging me to hold it for him. After a while he took his prize away, and has been buying things of that kind ever since.

"A man I used to sell old snuff boxes to, dates his passion for art oddities from the time I sold him a large metal bowl, which he still regards as the gem of his collection. It is a basin about 18 inches in diameter, surrounded by animals who are engaged in swallowing each other. A whale, with his tail bent upward so as to form a handle, is taking in a crocodile, who in his turn is disposing of a big-headed donkey; the latter animal is making way with a gorilla, who is straining every nerve to swallow a struggling goat; and so on till we come to a goose who is gobbling up a snake, who consoles himself by hoisting in a frog. A young devil, who forms the other handle, looks on with a grim smile, while he displays a scroll, on which is written: 'Ye big fishes swallow ye little.' This piece cost its owner \$3,500.

"This person had an old punch bowl of Yungching ware, on the edges of which there sat astride a number of curious figures in various stages of intoxication; one of them appeared about toppling over into the bowl, another had fallen over on the outside, but was preserving his neck by hanging with one toe caught on the edge of the article.

"Another of my old customers cared most for oddities which included some kind of a battle. He had a funny thing called 'Dwarfs Fighting.' Their idea of a knock out was pulling each other around by the ears, which stretched enormously. He had a piece for which he paid \$800. This man had a little old painting, which was more than quaint or odd. The design, as it appeared three feet away, was of a young and beautiful woman, very richly dressed. I was charmed with the effect, and withdrew for a better perspective. As I moved away, the magnified draperies merged into a dull mass of color, and I could distinguish through all the finery the bones of a skeleton occupying the place of the figure. It was a very skillful piece of painting, and cost the owner \$1,700. He bought it in Antwerp."

A Pendulum Fork.

[By HERMANN SIEVERT, in *Deutsche Uhrmacherzeitung*.]

IN THE accompanying cuts I am so bold as to offer two improvements in pendulum forks to my colleagues.

Figure 1 shows a new arrangement for regulating the drop. The fork *a* sits with its lining *b* revolvable, but well fitting, upon a shoulder of the anchor staff, and is retained by the piece *c*, which is firmly connected with the anchor staff. The piece *c* carries a set-screw *d* below, and on the other side a rather strong spring *f*, which presses against the pin *g*, fastened to the fork. The fork is, therefore, retained in place determined by the set-screw *d*. This arrangement of the screw between *g* and *b* excludes every unsteadiness in the con-

*Cf. paper by Mr. W. E. Hidden, p. 500, of this report, and *American Journal of Science*, xxii, 489, 1881.

† Collection of G. F. Kunz.

nection of the fork with the anchor staff, if the lining *b* is fitted on tight, best is with gentle friction. The arrangement does not overburthen the fork, especially not at the lower end.

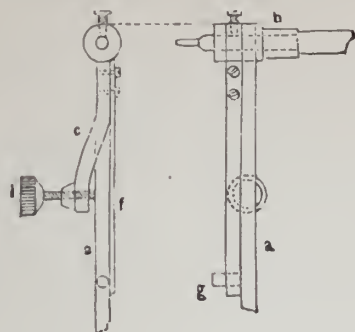

FIG. 1.

Figure 2 is a peculiar pendulum driving. The piece *k* is screwed to the pendulum rod *p*; the former carries the two discs *h h* upon two pivots. Upon these discs rests the driving pin *i*, the carrier of which, with the lining *l*, is movable around a pivot of the fork rod. Upon the bent-down end of the driving pin is screwed a ball *m*,

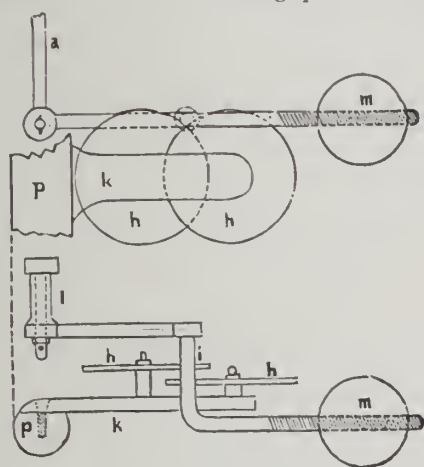

FIG. 2.

which serves for the equilibrium of the fork, and thus removes the weight from the pivots of the anchor staff. The three points *m i l* are arranged in a straight line, in order to lessen the pivot friction at *l* as much as possible. Although the driving pin *i*, with the discs *h h*, may also be located toward the other side, in the oscillating plane of the fork pin; but the impulsion for the pendulum takes place at a less favorable spot.

The following are the favorable points of this arrangement: By the revolvable discs *h h* an accidental friction is reduced to a minimum, and the guidance pin will not adhere, especially since it is without oil. The slight pressure upon the places of contact will prevent any side shake; the entire lifting, therefore, operates upon the pendulum, which is very important in clocks with small lifting. Finally, the arrangement prevents the damaging of the tooth points of the scape wheel, because the guidance pin passes to one side by the standing still of the clock, that is, it is lifted by one of the discs.

Echoes from the Bench.

To the Editor of the Jewelers' Circular:

Having read with absorbing interest many articles in your beautiful paper, relating to our trade, by an able corps of writers, and notably those on "Watch Repairing," from which I have culled many useful ideas, and, while there is evidently no lack of system in any or all of these, it has occurred to me that it might be profitable to call more special attention to this feature of improvement, and say something about *it* alone; so as to develop it where existing, and deepen the impressions concerning its value where it does not exist.

And while it must not be expected that everyone can send such

streams of information as a Dr. Bucklin, in the exceedingly attractive form you have now placed it, on optics, or a "Chordal" in the *Am. Machinist*, still let us hope that each little rill aids in swelling this richly irrigating river, if it does prefer to run a CIRCULAR course.

SYSTEM

is or ought to be to the good mechanic what the chart is to the mariner, warning him of a sunken rock here, a dangerous shoal there, etc. When I used to cross and re-cross daily by your ferryboats, and saw the crowds make a rush to get on before the present load of passengers could get off, the conclusion was irresistible that a *botch* controlled matters there. The lifting-gates show system *now*. On a voyage to India, an iron vessel, the *Sarah Sands*, burnt not only to the water's edge but literally gutted her—of the 2,000 soldiers on board not a soul was lost, nor so much as a finger scratched, possession was again taken of the hulk and all safely landed. Compare the contrast at the East River Bridge. These are sufficient to illustrate the point, the only difference being this, that the consequences of the one involve life, the other merely pecuniary loss.

Our lamented President Garfield, in an address to the students, eulogized the value of the margin; he said the model merchant, beyond that anxiety natural to men, cared not and counted not so much on what a thing cost, but how much of a margin could be had. Now this system gives to the mechanic a similar margin, that is, he has a margin of time saved, which the one without system has not; and he can utilize these marginal or saved moments in numberless ways, either in reviewing his work, or devising improvements, or doing more of other work.

Some of the old soldiers who served in the wars under the Duke of Wellington used to tell me, when a boy, how harsh and exacting in *drill* they thought their great commander was, but when the fierce charges of Waterloo came they changed their opinions very emphatically—their drill even Napoleon eulogized!

And so, when all is smooth sailing, and wind and tide favorable, even a green log goes fast, but it takes the steamer with its internal and *reserve power* to head against all these and still rate 15 to 20 knots an hour.

Young men, if ever misfortunes overtake you, you will find that this *system* will count more than a legion of those you had counted on as friends, who can furnish more criticisms than cash, because it costs less. You will not have to look far to see a goodly number of men who fail in middle life, and, because of the want of a trade as useful as ours, never come up again. If system guides you after properly acquiring our craft, and your *pluck* be equal to the emergency, you can soon rise again, aye, and even extort appreciation from your enemies, although they may be too proud to own it at once. You compel them to carry the burden of such a conviction wherever they go.

System develops self-reliance, which, like autumnal fruit, is the outcome of honest application.

No one doubts the necessity of a manufacturer with 600 hands whose rules demand exact time, seeing that the loss of *one* minute on the whole number is the equivalent of one man's day's labor. If, therefore, it be an imperative necessity in a factory, why not have one's tools arranged so as to have it as near as possible a similitude of the system on which the factories run, viz.: division of labor. And is it not logical to say this, if a manufacturer, wealthy enough to have so many hands, finds it a necessity to adhere to this rule so strictly, can one who has to *labor* in a sphere requiring so much skill afford to risk what the men of wealth cannot?

One of the afflictions to which a journeyman "on the wing" is subjected is the changing of benches; it takes quite a while to locate every tool and piece of material; for weeks at a time is he thus handicapped, and his employer, unless a workman himself, cannot be expected to allow for or sympathize with him in such a matter, having had no such experience.

After running the gauntlet of this experience, it was my privilege to be allowed to work upon a portable bench belonging to one of my

employers. This opportunity so favorably impressed me with its value that I had one constructed on a similar plan, with all left out which retarded and all put in which would facilitate work.

I now, without any bias, would very strongly urge upon every young man to save in other things, if he has not such an one, and get one similar to or better; you will eventually place the same value on it which the pioneer attaches to his gun near the frontiers of an Indian settlement. I do not propose to recommend it because it is mine, but because of its utility. And while it is doubtless true that there exists a wide chasm between the excellence of some workmen and others, the extremes, still although it may be considered an odd belief, I still believe that, with the great mass of workmen who average well, when they *will*, the greatest point of difference is in this, the one knows *how*, but *does not*—the other knows too, but *does his work conscientiously*. A convenient and systematic work bench comes in as a timely aid to brace a weak resolution. And who shall doubt the results? If you are able to infuse constantly more labor into each job than your rival, especially when we know that it sometimes amounts to two and even three hundred per cent.! And now let us make some

COMPARISONS.

The sedentary nature of our calling develops tendencies to dyspepsia. The owner of the bench alluded to being an excellent workman himself, evidently had this in view, as its height implied that all work which could be done standing ought to be—for it was convenient for this. What was its height need not be answered here, because of the varieties existing, not only in workmen actually, but in their tastes, for two of the same height might not agree on this. And, for convenience, we will call the bench I tried No. 1, and that of my own No. 2. No. 1 has a blunder in principle in common with too many others, the lathe occupies its left-hand end and thus usurps the room so invaluable for drawers; not only has the band to run through this, but the wheel is there too, and produced on my left side or knee a most sensible chill, which I dared not ignore, a fact more stubborn than even my own will! To compensate for the absence of this drawer room, so needful, No. 1 has on the right, besides all that can be crammed into the middle, a whole tier of drawers down to the bottom board, each drawer very properly becoming deeper as it nears the base. I do not remember if it had the usual mode of locking them all up as numbers do, by having the drawer fronts recede from the front of the bench to give room for the cover-all-board, which, like an old-fashioned window shutter, covers all up, thus absorbing an inch or more of the entire drawer front, and every time one gets a tool out he loses this inch or more out, and in also, ere he reaches what is wanted. I am too lazy to do so much for nothing. Now notice this other point with No. 1: When I rose up to wait on a customer the seat I sat on had to be pushed back while I poised myself, for to swing to the right was impossible because of the drawers, nor to the left for the wheel, at the same leaning forward to get rid of my own weight on the stool, and, when sitting was resumed, all these motions reversed had to be gone through with, while hauling the seat after me. Drawers in sets are usually made with a cross bar or front between each other. Considering this an unprofitable plan I avoided this in No. 2. My seat being a very solidly made stool with three legs, and a very large screw with brass nut of some three inches in depth, with the seat solidly upholstered. Once set down in its place I aimed at such a construction of bench as should admit of the stool's standing where it was placed, and that whoever should work on this stool should, like a certain noted politician, be able "to swing around the circle," with the knees under all the drawers, and, by resuming the seat a little sideways, its convenience is all that can be desired. By this arrangement you will see the policy of running the drawers on slides or tongues on their sides, thus avoiding the waste caused by cross pieces between them, the aim being to have every available inch of surface for tools, and also to have that surface as near the top as it were possible, thus leaving ample room below for the knees to get under.

And now let us revert back again to No. 1. The drawers that are lower down than the knees are like the others in this respect, growing deeper in order to hold larger and consequently heavier tools, and as the base is neared it is found possible to open and close these drawers only by rising from the seat and stooping to get the tool wanted, and if such tool be in the way it has to be replaced by the same loss of time and energy. All this is avoided in No. 2.

But the question spontaneously springs to the lips, where do you put your lathe in No. 2? On the left end of the bench, with a special arrangement to hold it as per cut.

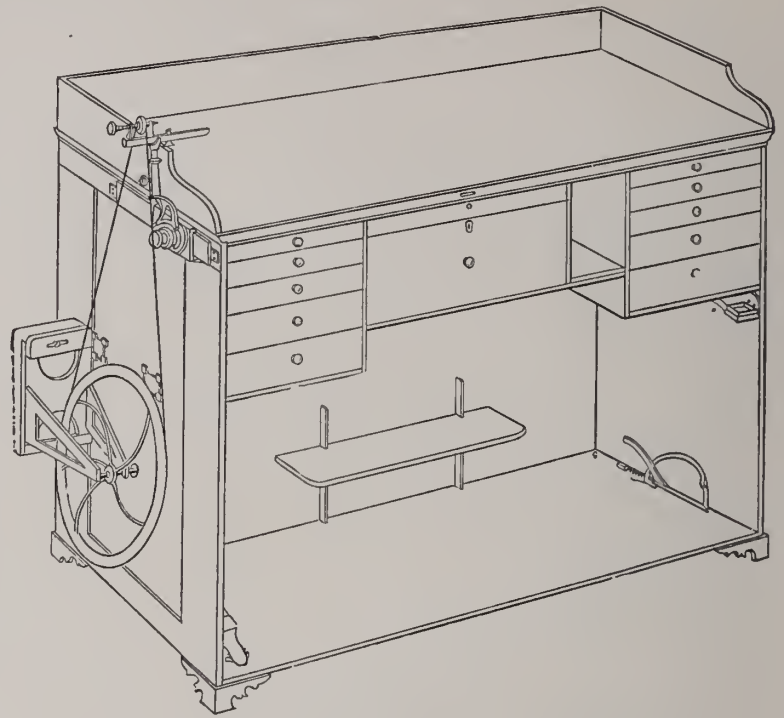

DESCRIPTION.

This No. 2 is 4 feet long; 21 inches wide; 3 feet, 10 inches high; each tier of five drawers is a foot wide, the middle ones being 15½ inches, and the catch-all slide beneath these 18½. The inside of the front bar of this slide has recesses cut out, and holds four bench keys, 1, 2, 7 and 8, which a notch of rubber holds in place well. Upper middle drawer 1¼ deep (inside), has two rows of phials holding materials in homeopathic doses, which betimes ferments into allopathic charges, and thus furnishes our working margin. By boring a series of holes edgewise through a board, the width of which is less than the length of the phials and thus furnishes room for the fingers to seize quickly, and by making these holes of a size large enough for these to pass through, then saw the board through the middle of the holes edgewise and you have two rows of corrugated tops that, when covered with bright glazed green paper, always look clean, cheerful and attractive, a duty every man who loves to make home happy owes his family, and why not himself and his bench, at which so many of his hours of life are spent? It is just 15 inches from top of board to bottom of drawers. Under those at the right the usual slide for chalk, etc. The foot rest or shelf cannot be made to show its points in the drawing; these two uprights contain notches like a book-shelf, for raising or lowering it to suit. A shaft (lengthwise) is controlled by a lever, which operates the two spring-clicks at once, and is the original idea, with some two or three years of priority for a claim on that now in use on the Crescent St. watch and others, for letting down the mainspring, which was very unceremoniously appropriated and patented, and, had I but retained copy of letters sent, would have resulted differently. The position of lathe will almost explain itself, as it slides along the slide to any desired point of convenience. Every morsel of it and the wheel's appointments can be dissected in *half a minute*. The way by which the casting holding the wheel is secured is by a thumb-screw operating like the Swiss dial-screw. The socket holding the lathe shank contains a spiral spring to tighten band, and a set screw, as shown, to keep it there.

It was made of (black walnut) lumber seasoned some five years outside and six months around a stove in-doors before making, and of course not a seam has ever started. Anticipating this question, would you not prefer to sit at your lathe, at least part of time, when on a fine job? Yes, I would; and this is a long contemplated improvement, and the only one of any gain worth noting after a fifteen years' trial of it; but still the great bulk of lathe work I would do as now—but would have all improvements interchangeable—that is, the new plan in view would allow lathe to be worked as now or change it momentarily to the board or back again at pleasure.

Next lathe I get, and that will be soon, if I cannot escape from the dyspeptic bench (however good), shall have made in this way: Instead of the usual shank with a screw threaded some half way down, and going through the bench board, shall have a short projection under the usual broad base (which is necessary to give firmness), say three-fourths of an inch, which shall go down into a socket, this socket let into the bench, not through it, but well secured and to remain there, and barely flush with its surface; then have this short projection split like a chuck, only let its tightening be the reverse of the chuck, viz.: to spread instead of to contract; of course this socket would correspond to a dovetail, widest at the bottom. Lots of devices can be furnished by eccentrics or otherwise to operate this and tighten it. This socket and its corresponding projection to be round, so as to allow the lathe-bed to be swung round out of the way when not needed.

Of course it is now used without any countershaft, but when one is added said shaft will extend nearly the whole length of the bench, and convenience may call for more than one such socket on the board.

No. 2, with its ten drawers, all lock at once; this is quite a simple arrangement, but has to be well fitted to work well. The top is mahogany in one piece, but underneath that is another of cherry; in this cherry leaf is located a brass box, with two levers, pivoted midway of their length, both inner ends of which meet almost close together; both ends of each have a knee. When the key turns up the lock bolt of course both ends of the levers are tilted up, while their outer ends are depressed, and push a short bolt located directly under each other through the drawers down where each one tickles its neighbor; a spiral spring in each one returns it to its place when the lock bolt is turned back.

Being solid black walnut outside and in, of course it is heavy, and so to be handy, the drawing of a lever, seen at the bottom of right end, throws it up on casters, thus making it portable, and by pushing in a snap spring the lever is replaced and down goes the bench again. This seems a long story, doubtless, about one implement, but just look at the labor bestowed on the foundations of any modern house or store where convenience is expected and the results well justify the trouble and expense. You may turn it any way to suit the light; work in a new room every day and the relationship of tools and materials are still the same, so that there need be no diminution of effort or of speed.

The mode of detailing the tools in No. 2 would not be of such general interest to others as to warrant a description here, their arrangement ought to be left to each one's own judgment, as, for instance, a left-handed man would reverse the usual order of things.

The drawers are partitioned as one intends to locate tools, for instance, in No. 2 the upper right-hand drawer has files alone, and divided into four parts; the one below this a row of plyers and cutting nippers occupy the front, as they are most used, tweezers and other small fry further back; all located with this purpose in view, that none or at least as few as possible shall have to be laid on the top of each other. On the left broaches, gravers, etc. for lathe work, then one next the bottom on the left holds mainsprings and all their appointments, and naught else; and directly under this the lathe is laid in every night, with a full-sized box of chucks for the same, and so on.

In some communities when a lad leaves school the conception that

he is *perfect* because he has graduated precludes that possibility for improvement which ought to exist at least up to eighty years. Where I hail from the idea was sought to be infused into the young that what was received at school was merely rudimental, and that whatever training was had merely whetted the appetite for more mental aliment. Following up in the spirit of this teaching, let me assure you, sir, and your readers, that this is not intended for a boast or a challenge, but with the hope that it may animate others to *post* us on their own and very likely better modes, and so be mutually beneficial, and thus stimulate a file of correspondence which shall supply to our craft, through your attractive columns, a similar and a ten-fold higher, because more useful, pleasure, than one when in younger days, at a certain spot, the stage-coach with its load of twenty-four was usually stopped to give us the chance to hear some three or five distinct echoes of the "Guard's" horn from the surrounding wooded hills. Then may "Echoes from the Benches" give forth no uncertain sound, and every contributor shall aid with his best efforts in helping to elevate the horological platform to a yet higher plane than when he began its study or practice.

You may have heard of the old Scotch preacher who boasted of having preached for two hours without stopping. And were you not tired? O, no; *I did not mind it*; but it would have done your soul good to have seen how tired the congregation were! Being afraid of a similar inference must defer adding more now, but may, if desirable, give some applications again. Respectfully yours,
Rochester, N. Y.

I. H.

Practical Treatise on the Adjustment of a Four-Jewel Cyl- inder Watch.

[First-Prize Essay by HERMANN HÖRRMANN.]

Continued from page 313.

86. A straight fastening of the pin for the male stop is the most secure; it is to be provided with a very small notch, cut in with the screw-head file. In many cases, and especially when the hole for the fastening pin has been drilled very deep, the notch should be cut with a small toothed disc, since the solidity of the tooth is injured by too deep a notch, and defects are easily generated thereby.

87. In order to replace a star, pick out one that comes nearest in size, from those on hand. After it has been glow-heated, before working on it, fit first the hole to the boss, provided that this be good and capable of offering the sufficient amount of resistance, while in a contrary case, turn a new sink upon another part of the cover, and leave the boss as heavy as possible.

Turn the sink before you have tapped the hole, since in the latter case the tap will come out of true.

88. If, when replacing the star, its hole is very small, it is advisable to at once widen it with a suitable drill. One only a trifle smaller is broached by turning the broach always to one side, otherwise the hole would easily be shifted out of center. When broaching, remove the burr from time to time.

89. After the hole is suitable with regard to size, file or grind the star flat underneath, and lack it with shellac upon the barrel cover. This is then fastened in the clamp-head of the universal tool, and the sink is then turned for the screw head, sufficiently deep that the graver touches the boss.

90. After both parts have been cleaned from shellac by boiling in alcohol, the stop-star screw is made. It is best to manufacture the screw one's self, as the same thread can be cut in the boss, and the head of the screw can be turned to a suitable size. On account of despatch, many watchmakers prefer the screw found in commerce.

I believe that it is unnecessary to mention that the screw-head must be flat and occupy the entire space of the sink; also, that it must be as low as possible, in order not to scrape on the dial, or, with double bridge, not to scrape upon the lower one, and that, finally, the screw-end do not protrude upon the inner side of the cover.

91. After the stop mechanism has been corrected, and any accidental pinchings are most suitably remedied by grinding both parts with oilstone powder and oil, it is to be tempered and annealed dark blue.

92. After tempering, it is necessary to grind the frictional faces of the male stop lengthwise, also to slightly round off the corners of the tooth points of the star, so as to remove the sharp edges.

93. As is the case with any other steel part, a handsome grinding makes a show superior to a bad polish. It is well, therefore, to round off the corners of the stop-work parts with a good oilstone, and to polish afterward, for which purpose a burnishing steel suffices; finally, give a good stroke with emery upon both parts.

94. In case the stop work square of the spring arbor does not protrude sufficiently, and where the thickness of the cover does not admit of turning a sink, a small shoulder, reaching down to the bottom of the square, is left to stand under the male stop, but

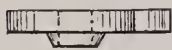

FIG. 11.

care must be taken that the stop does not touch the cover.

On the other hand, it is necessary, with an over-long square, to set it somewhat deeper, so that stop and star stand at the same height.



FIG. 12.

95. It is often found in new watches that the hole for the fastening pin is burst open or drilled from the side, so that the pin cannot be fastened securely in the ordinary manner. It is therefore best to fill a bursted hole with a brass pin, which is to be soldered in, and next to drill a smaller hole in the appropriate place.

96. With an oblique hole there is no other remedy than to drill another one from the opposite side—except it be that the hole offers

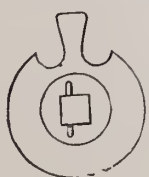

FIG. 13.

a firm hold for a pin and that the stop can be fairly strong, in which case a sink is turned in the middle, which permits the pin to be fastened, and to place the stop in position in a four-fold manner, according to necessity.

97. Finally, if the square is too short to admit of the drilling of a hole for the pin, make a thin steel bridge, which is fastened with two sunk screws, over the stop work; one of the screws is placed in the boss of the star, the other upon the opposite side of the cover.

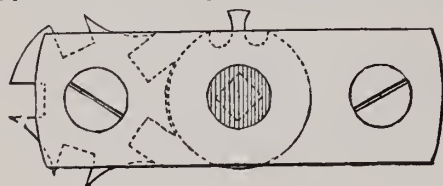

FIG. 14.

CHAPTER IX. THE DEPTHING.

98. In order not to repeat the same remarks at each depthing, it will be best to preface these paragraphs with a general practical method of investigation, suitable for all deptings, and the manner of improving them.

As is known, the deptings of watches are generally investigated by feeling them, since they can frequently not be seen. It demands an experience of years to judge a depthing by the touch, and it may occur after all that the repairer is deceived by a shallow one. Whenever it is practicable, small inspecting holes should be filed in, so as to satisfy one's self both by seeing and feeling. Also the trying of a depthing in the tool after an exactly set distance of centers is advisable. (See Art. 105).

99. As unconditionally necessary for a good depthing is, first, that the pinion fits to the wheel, that is, that their respective proportions are correct; second, that both parts run true; third, that the division is exact, and, fourth, that the wheel teeth, as well as the pinion leaves, are of fitting form.

The deptings are passed through by pressing with a pegwood, held in the left hand, pretty strongly against the pivot of the pinion at the upper side of the hole of the wheel pivot to be driven, so that the wheel moves, while the right hand guides it with a thin and pointed pegwood, several revolutions in the direction in which the watch moves. Now, observe whether the driving takes place gently and without scratching and side friction, and test the shake of the teeth at different places.

100. If the depthing is visible, pay attention to the following points: 1. That the entrance of the wheel tooth into the pinion take place freely and with sufficient shake between the back of the wheel tooth and the next pinion leaf.

101. 2—That the first engagement, or the exact point of the beginning of the driving, takes place upon the line of centers. This, however, is possible only with the center pinion in cylinder watches, as 10-leaf pinion, and with all those of a higher number, since by pinions with a smaller number of leaves an entering friction is necessarily present, increasing in quantity with the decrease of leaves. If the driving commences too far from the line of centers, it may be due either to too large a pinion, unduly strong pinion leaves, insufficiently pointed rounding, and finally to too shallow a depthing.

102. As previously remarked, the tooth, in whatever position it be, must have sufficient shake in the pinion. The depthing of the scape pinion is given a little more shake, to cause it to pass more easily, and not be so easily choked up by dust and fibers getting into; it while, on the other hand, it is not hurtful to give less shake to the barrel depthing; in this case it depends rather upon the strength of the tothing, so that by the bursting of the mainspring the teeth be not injured.

103. During the driving, the rubbing surfaces must, as it were, unwind themselves from each other with uniformity. When the progress is closely watched with the magnifier, it is not difficult to perceive when one slides off too quickly, which is due either to a badly formed rounding or to a pinion which is not of the correct diameter, or else to too deep or shallow a depthing.

104. It is also important to observe the end of the driving. It is often found that a rapid sliding or drop takes place here. It is generally caused by too small a pinion, too shallow a depthing, or rounding either too short or badly formed.

105. If in doubt concerning a depthing which cannot be observed closely in the plate, it is advisable to try it exactly in the same distance of centers as found in the plate in the depthing tool, by passing the driven wheel rather tightly between the centers of the tool. If it also performs badly here, ascertain the reason, whether the mutual proportions are incorrect, whether both parts do not perhaps run untrue, whether the division is incorrect, or whether the wheel contains thick and thin teeth at the same time, and, finally, whether the forms of teeth and leaves are suitable to each other.

106. When examining the proportion of wheel and pinion, only the pitch diameter is to be measured. Since this can be done only with difficulty, the proportional circle is generally made use of, or the ordinary method of measuring the full diameter of the pinion with the pinion gauge.

According to this, the 10-leaf center pinion must measure 4 full teeth of the barrel, the third wheel pinion, if of 10 leaves, also 4 full teeth of the center wheel, but if of 8 leaves, 4 teeth at the points less $\frac{1}{4}$ of the space; the fourth wheel pinion the same; the 6-leaf pinion of the cylinder scape wheel is to measure 3 teeth over the points, or a little more.

The following cut represents the measurement; a 7-leaf pinion has been added, the diameter of which is to be a little less than 3 full teeth; it is almost exclusively found only in anchor watches:

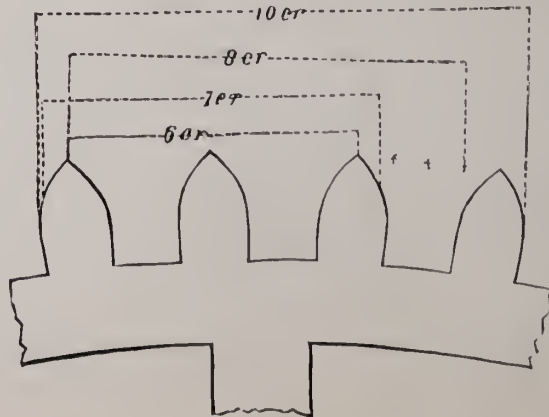

FIG. 15.

I would also add here that the diameter of a 12-leaf pinion ascer-

tained in this manner with the guage is to measure 5 teeth over the points (or better $4\frac{1}{2}$ teeth).

This method cannot lay claim to be exact, but simply serves as a starting point.

107. If a pinion is too small, and is not to be replaced, the repairer may have recourse to prolonging the straight flask on the side where the tooth attacks, as is shown at *a b* in fig. 16.

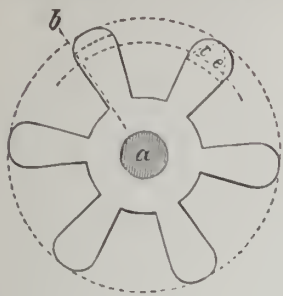

FIG. 16.

This is effected by laying the pinion upon a filing wood, and suitably scraping it with a sharp graver. The drop of the wheel tooth is thereby retarded and is weakened. A moderate drop is less hurtful than butting and side friction with too large a pinion. These faults of an over-large pinion are moderated by making the rounding of the leaves with the graver more into a pointed form, as shown at *c, c'*.

108. The butting occurring with an unduly large pinion, completely annuls the effect of the depthing. The side friction uselessly consumes a part of the motive power, causes the rapid destruction of the frictioning faces, and sometimes the standing of the watch.

The drop, with too small a pinion, also causes a loss of power and a wear, but to a less degree only; and it will never produce the standing still of the watch.

109. With too large a pinion, the depthing is improved by bringing the motion centers of wheel and pinion closer together, or, in other words, if the depthing is set deeper. With too small a pinion, however, the depthing must be retained rather shallow, to insure a better passing through.



FIG. 17.

110. After having previously set the barrel, click work and stop work in order, we find as next in order the inspecting and correcting of the depthing in the center wheel. For this purpose, file into the plate, in the vicinity of the center wheel hole, two small inspecting holes, but in such a way as not to jeopardize the solidity of the pivot hole, in case it requires to be bushed. This is done for the obvious reason of observing the depthing from below through the two holes.

111. Now mount the barrel and center wheel together in the plate, and drive this depthing, both ocularly observing and feeling it. If it is too shallow, you will be compelled to move the barrel nearer to the center wheel; while, in the case when it is too deep, the barrel simply requires an additional rounding.

112. When I served my time, the occasion often arose to make the barrel depthing deeper; my employer required me to close upon the one side of the bridge as well the hole for the screw as that for the foot pin in the plate, and to bite off the pin with the nipper.

The barrel was then displaced and moved until the depthing was correct. After this the hole for the screw was drilled, and then that for the foot pin in another place.

113. In another workshop in which I was employed afterward, this method was far too tedious for my employer. He acquainted me with his system of doing the job, and I must confess that it was an improvement. After the center wheel had been taken down, the screws of the barrel bridge were somewhat loosened, and the click spring also taken down. A brass punch was then taken, and slight taps were struck upon both sides of the bridge as well as in its center. The center wheel was mounted again, and I was surprised

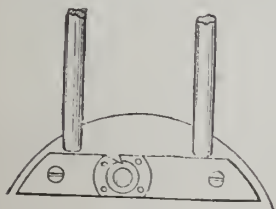

FIG. 18.

when I saw that the depthing had been set in order by the three taps

114. Since that time I have often corrected the barrel depthing in this manner, provided that the depthing was not either unduly shallow or deep. By this manipulation the bridge is bent in the center, and also its foot pins are bent. If the screw holes in the bridge are

very small, file them somewhat elongated in the direction opposite to which the bridge is to be moved. Also chamfer the holes for the foot pins in the plate above with a three-cornered chamferer, so as to procure space for the bending of these pins.

115. The improvements of depthing with a double bridge barrel are not quite as facile. When you have such a watch, examine first whether the barrel stands straight. If it is oblique, ascertain which hole it is best to bush to obtain a correct depthing, whether the upper or the lower one. Next fasten the plate in the universal tool, center it according to the correct hole, open the hole by turning, and bush it in the same manner as was described for the center wheel holes. (Art. 40).

116. Should the depthing be either much too deep or too shallow, make the hole in the lower bridge longer by filing it with a round file in the corresponding direction, broach it, bush it, and by this turn open the upper hole, which is then to be bushed in the known manner, and observe that the spring arbor receives its requisite quantity of end shake, and the barrel is placed at the correct height.

If the holes are otherwise serviceable and the barrel stands straight, but the depthing is too deep, place the barrel in the engine and round it. Of course, not much is to be taken off at a time, and it is advantageous to make use of a metric gauge, so as to thoroughly control the quantity, whereby the repeated and disagreeable mounting and taking down of the barrel parts is avoided.

117. It may happen with ordinary watches that when the center wheel pinion is too low, and often, in order to obtain room for the free motion of the center wheel, this has been filed thinner, although above the pinion a shoulder of the reduced center wheel is left standing. Now, if the center wheel and barrel go right close together, the barrel teeth rub and butt upon this shoulder. "Of two evils choose the lesser," also holds good



FIG. 19.

in this instance, and if the barrel, so as to correspond with the pinion, is not to be placed lower, either a new and longer pinion is to be turned in, or else the teeth of the bridge must be beveled off somewhat. (Art. 13).

118. This is done upon a turning tool, by holding a sharp file with a very fine cut against the barrel, fastened upon a turning arbor with left thread, and afterward causing the beveled tooth circumference to pass on an oilstone, whereby the burr is removed from the teeth, and the beveling assumes a gold-like color.

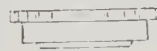

FIG. 20.

119. But pay particular attention that the barrel moves free in all directions in the plate, and it is advisable, in case of scant shake and distance, to turn out a little.

When this depthing has been set to order, the barrel is left in the plate, and the minute work inspected.

(To be Continued.)

The New York Jewelers' Association.

NINTH ANNUAL BANQUET AT DELMONICO'S.

THE REPRESENTATIVE manufacturing jewelers of New York assembled in one of the spacious parlors of Delmonico, at Fifth avenue and Twenty-sixth street, on the evening of November 8, for a few hours' social intercourse and recreation, driving for a while from their minds all trade thoughts and troubles of a personal nature, meeting together as members of the New York Jewelers' Association, with confidence in each other as members of a fraternity representing one of the most important interests in the country, and coming together to converse over the social board, free from insidious distrust and asperities smacking of the shop. The occasion was the annual dinner of the New York Jewelers' Association. The dinner began at seven o'clock, when the assembled jewelers, about 150 in number, including the invited guests, marched

into the banquet room and sat down to elegant, well-provisioned and elaborately decorated tables. The guests' table was on the platform at the western side of the room, and was presided over by the President of the Association, Mr. Thomas G. Brown. The other four tables, arranged at right angles to this, were occupied by the members of the Association. Adolph Bernstein's orchestra, from the balcony over the banquet room, welcomed the company as they entered, and throughout the evening contributed to the enthusiasm of the occasion with enlivening strains from "Patience," "The Pirates of Penzance," "The Mascot," and other popular operas and operettas.

The room decorations, which had been provided by the Committee of Arrangements, did these gentlemen full credit, and were elaborate and artistic. The jewelers, as a craft, are artistic lovers of nature, and the Committee, catering to this taste, resorted largely to the garden and hot-house for the decorations of their festival room. Vases containing a profusion of cut flowers, tropical plants and palms, could be seen all around the spacious, well-proportioned apartment, and pots of various species of ferns and flowers outdid the brilliant chandeliers and candelabra, the patriotic bunting and artistic confectionery, in lending enchantment to the room. In front of the guests' table was a double row of blooming plants of rare species, many of them blossoming profusely. The effect was artistic and most pleasing to the eyes of the cultured gentlemen seated around the tables, and reflected great credit upon the excellent taste of John M. Hodgson, the well-known florist, of Fifth avenue. A large banner, bearing the coat of arms of the United States, and another of New York State, set off with flags, added to the adornments of the room, and clusters of flags and brilliant shields increased the effect. Magnificent lamps, with colored globes, and confectionery decorations of unique and elaborate design, contributed to the charm and beauty of the tables. The wine and viands, it is scarcely necessary to say, were of Delmonico's best, and gave abundant satisfaction. Following was the menu:

MENU

Huitres		
POTAGES		
Consommé Sevigné		Bisque d'écrevisses
Olives		Celeri
HORS D'ŒUVRE		
Timbales à la Périgordine		
POISSON		
Aiguillettes de bass à la Venitienne		
RELEVÉ		
Filet de bœuf à la Maréchale		
ENTREES		
Ailes de volaille aux truffes		
Mignons de chevreuil à la Royale		
Crabes farcies		
SORBET		
Young America		
ROTTIS		
Perdreux flanqués d'ortolans		
Salade		
ENTREMETS		
Haricots verts	Tomates	Pettis pois
SUCRES		
Croûte aux ananas		
Gelée Reine Claude		Charlotte à la Russe
Bavaroise d'abricots		Cornet à la Crème
Petits fours		Gateaux variés
Pièces Montées		
Napolitaine		Soufflé aux marrons
Fruits and Dessert		
Café		

Le 8 Novembre 1883

DELMONICO.

The names of members and their guests were as follows:

ASSOCIATION GUESTS.

Rev. W. F. Watkins, D. D., Rev. J. R. Paxton, D. D., Hon. Noah Davis, Hon. Isaac H. Bailey, Hon. Theo. Roosevelt, E. T. Bartlett, Esq., R. G. Rolston, Esq., J. Seaver Page, Esq., D. H. Hopkinson, Chas. L. Tiffany, Esq., Algernon S. Sullivan, Esq., H. Olmstead, Esq.

MEMBERS AND GUESTS.

D. F. Appleton, E. C. Fitch, A. C. Smith, N. Matson, T. B. Bynner, Henry N. Fisher, F. R. Appleton, W. H. Hennegan, R. N. Peterson, D. Valentine, Chas. N. Rosenfeld, Geo. C. White, Jr., H. Béguelin, J. W. Beacham, A. Unkles, E. Holbrook, W. C. Spencer, Geo. Wilkinson,

Wm. Thurber, Geo. H. Houghton, Thos. G. Brown, Thos. B. Brown, Wm. A. Brown, Aug. L. Brown, H. Tilden, Jr., H. Semken, Louis LeLong, H. D. Lowd, A. H. Whitehouse, Benj. Shreve, Jos. F. Chatellier, David C. Dodd, Jr., J. A. Dodd, J. W. Bailey, A. Carter, Jr., A. K. Sloan, C. E. Hastings, Geo. R. Howe, C. Weaver, H. S. Cozzens, J. T. Bailey, G. H. Ford, S. B. Sanford, Edwin Harris, J. H. Brazier, W. C. Kendrick, A. H. Smith, W. N. Vogell, C. J. Greene, G. C. Taylor, N. Taylor, W. L. Rich, R. H. Galbraith, E. Lomdelet, R. C. Black, Leon Barre, J. E. Read, C. Picks'ey, C. A. Starr, J. G. Bacon, J. W. Miles, H. B. Dominick, L. B. Haff, Alexander Dominick, W. N. LeCoto, H. S. Woodbury, W. F. Michael, S. Cottle, Dr. Shreve, C. H. Crump, H. C. Ostrander, P. T. Tunison, Jas. P. Snow, Jos. B. Bowden, D. H. Buell, W. W. Wattles, F. S. Douglas, A. O. Headley, R. C. Green, J. C. Aikin, Jno. B. Shea, Isaac M. Miller, Jas. W. Miller, Hon. Henry Long, Geo. H. Fish, Thos. LeBoutillier, Bolton Hall, W. R. Alling, Alex. Stowell, Jas. H. Hart, Wm. S. Hedges, Jas. Hedges, Geo. A. French, A. B. Carlton, David F. Conover, C. E. Breckenridge, Jas. M. Andrews, N. H. White, C. G. Alford, H. C. Hardy, C. H. Brahe, Henry Molineux, W. H. Atwater, Jno. C. Atwater, W. H. Stevens, F. B. Jennings, A. O. Jennings.

While the coffee was passing around, President Thomas G. Brown, beaming benignantly on the assembled guests and members, rapped his gavel on the table for silence, and proceeded to address the company as follows:

ADDRESS OF PRESIDENT BROWN.

Gentlemen of the New York Jewelers' Association:

It is my privilege and province to-night to represent and speak for those who, for the most part, or rather in some degree, have been early taught, like myself, to express their thoughts in the silent but eloquent language of form and color rather than in the choice words of the scholar and the accomplished speaker, such as we have with us here to-night. And so I come up here at this time with some m'sgivings on my own part. Feeling that although it is one of the pleasantest, it is at the same time, and in a certain sense, one of the hardest duties of the President of this Association, after enjoying the good things that Mr. Delmonico has provided for us, to stand up in this place amid these (to him) novel surroundings, in the glare of these lights, with these distinguished and learned gentlemen on either side of him, and these very industrious gentlemen of the press before him, and the members of this Association and their friends smiling at him, to make what by courtesy may be called a speech. But the march of events is inevitable, and, as the time drew nigh for your annual gathering, I knew that something had to be done—some words, and thoughts, and sentences arranged that might in some small degree, at least, be satisfactory to the speaker and appropriate to the occasion. Not thinking of anything that would exactly "fill the bill," as we sometimes say in business, I ventured to ask a friend of mine what kind of a speech ought to be made. "Well," said he "that depends very much on what you want to say,"—a remark that he no doubt considered very profound. "Although I can't very well tell you what to say, I can perhaps tell you what not to say, if you will allow me. First of all, don't be long-winded; don't try to make the great effort of your life; don't say anything about those tanned hides from Tewksbury; don't allude, however remotely, to the Goldsmiths' Guild, of London; and, of all things, don't try to say anything smart or funny—leave the funny business to the speakers of the evening, they are used to it and can stand it, and you can't; you may be serious and even pathetic, and get laughed at, as you probably will, but if you try to say anything funny, and fail, it will be a 'cold day' for you." Well, I thanked my complimentary and good-natured friend, and said to him that I could not very well be long-winded or make the great effort of my life, for indeed I had nothing or very little to say. In regard to those tanned hides from Tewksbury, I hear that a distinguished guest with us to-night, interested in the leather trade, intends alluding to those hides in his speech to-night. As for the Goldsmiths' Guild, of London, it has done duty in this Association for the last six years, and I propose to give it a rest. As for saying anything funny, I have often tried, but I never have succeeded (but once) in saying a funny thing in my life. The distinguished counsel of the Association, Mr. Bartlett, found it out, and got it away from me, and I hear intends using it in his speech this evening. But, be all this as it may, time gallops apace. The season has come round again, our vacations, like all pleasant things, have come to an end, and are well nigh forgotten. The harvest moon no longer lends its beauty to the evening sky, the corn has ripened and been gathered into barns and elevators, and other convenient places. The autumn leaves have withered and fallen, and the autumn wind whistles through the dry branches, and these signs in nature and elsewhere remind us that the serious business of the year is about to commence, and it is high time that the jewelers have their frolic, and so we come to celebrate the ninth anniversary of the Jewelers' Association.

I am glad to meet you, fellow-members, and your friends with you. Time seems to have dealt kindly with you since we last met. I am glad to see you look so comfortable and happy. I am aware that many, and in fact most of you, rarely or never take anything stronger than water. Still, I trust you may find the menu and the cuisine in other respects to your satisfaction, and that you may also find sufficient inspiration in the events of the evening, as they transpire, to make the occasion an enjoyable one. As one of the earliest, and, moreover, I am sorry to say, the oldest living member of this Association, my immediate predecessor (save one), ex-President Appleton, alone excepted, I have watched its progress from the day of its formation through all these years, I have seen it grow in numbers, in strength, in wealth and influence. I have seen the unremitting and patient labor that has been bestowed upon it day by day. I have seen its arms stretched out, gathering in and building up, little by little, until at

last you have an institution, or an organization rather, of which you may well be satisfied, of which you may well be proud. Moreover, you have founded a system as nearly perfect as earnest endeavor can make it, which, as the means to an end, and that end the help and guidance of the business man through the devious ways and the dark by-ways of trade, stands to-day among kindred associations without a rival, and so as this Association, and others like it, shall grow and prosper and multiply, and material prosperity shall follow in the footsteps of earnest and patient endeavor, and leisure and comfort and culture shall follow in the footsteps of both, and at last find their true expression in the higher and various forms of industrial art and artistic beauty—so shall the jeweler, and the silversmith, and the watchmaker, and the bronzer, and the potter with his ever-restless wheel, and the moulder, and the modeler, and the forger, and all the various workers in gold, and silver, and copper, and bronze, and brass, and iron, way back through all time to that early dawn when

“Old Tubal Cain, the man of might,
In the days when the earth was young,
By the fierce red light of the furnace bright,
The strokes of his hammer rung.”

I have omitted to mention in their proper place two workers in metal, familiar figures in almost every household, high and low—I mean those two distinguished artisans, the plumber and his faithful helper, like Don Quixote and his trusty squire. These, as well as the others I have mentioned, shall find that there is an æsthetic as well as a material side to every calling, both high and lowly, and all together shall be lifted up to a higher plane, and a broader and loftier aim and purpose. So, fellow-members, stand by your Association, continue to give it your constant and earnest support. It is a tree of your own planting, see to it that it does not wilt or wither, or decay from neglect or cold indifference on your part. Give it a little more of your time, now and then, from the leisure and even from the busy hours of the day, and like the Egyptians of old who cast their bread upon the falling waters of the Nile, it will come back to you as it did to them in many ways and after many days. And now I have to speak the pleasant word of welcome to our guests to-night. I am glad to see the familiar faces of some old friends with us again. They are welcome now, as ever and always; I am pleased to see the faces of some new friends. Both old and new, each and all, in the name of this Association, I give you all a warm and cordial greeting. One other word and I have done. Although this is in all probability the last time I shall speak to you from this place, I hope to be with the boys down there again, and perhaps many times. But life is uncertain, and be the times few or many, I trust we may all meet, members, friends and guests, in that city where walls are sapphire, and where gates are pearl.

The remarks of Mr. Brown were frequently interrupted by applause and laughter, his witty hits being highly relished by his hearers.

Mr. Henry Simpken, of Washington, then proposed the health of President Brown. Mr. Simpken said: “Gentlemen—Not being a member of this association, but simply an honored guest, I propose the health of your worthy President, Mr. Thomas G. Brown.”

The President's health was drunk with three hearty cheers and a “tiger.”

PRESIDENT BROWN—I am now to propose the first regular toast of the evening,

“The President of the United States, Chester A. Arthur.”

[The President read a letter from President Arthur, regretting his inability to be present at the banquet].

THE PRESIDENT (*continuing*)—The next regular toast is

“Our Nation; an indestructible Union composed of indestructible States.”

Mr. Carl Schurz was to have answered to this toast, but he is not present here this evening.

“The Empire State”

is the next regular toast. The Governor of this State we expected to be with us to-night, but the Secretary heard from him to-day that he is not very well. (Laughter).

The next toast is

“Competition; He that wrestles with us strengthens our nerves and sinews and sharpens our skill. Our antagonist is our helper.”

It is scarcely necessary for me to introduce to this company Hon. Algernon S. Sullivan (Loud cheers and clapping).

ADDRESS OF ALGERNON S. SULLIVAN.

Mr. President and Members of the New York Jewelers' Association:

If any other dinner party during this winter wants to enter into competition with this one for efficiency in hand clapping, I will bet my money on this club. Ever since I came here to-night I have been struck with the effect of association with you gentlemen in producing a spirit of competition among those gentlemen who are your guests. I do not wish to make remarks about my neighbors, but it has been very evident during the

evening that the spirit of competition in this line on my right has been in very active operation. [Mr. Sullivan sat at the extreme left end of the table of honor; next to him in successive order were Rev. Dr. Wilbur F. Watkins, Mr. C. L. Tiffany, Judge Noah Davis, Mr. Thomas G. Brown, Rev. John R. Paxton, Hon. I. H. Bailey, Mr. R. E. Ralston, Hon. Theodore Roosevelt, and Mr. E. T. Bartlett on the extreme right.] The Chief Justice of the Supreme Court of this district has shown that he was determined on his part that Mr. Tiffany should never clean his platter more thoroughly than the head of the New York bench should do it, and as to the number of bottles that has been disposed of, the competition between Mr. Bailey and the entire body along one line of the table in front of him has been very active indeed. And that reminds me of a story on the subject of competition that came to my ears last year when I was here, and has been mentioned again to-night by one of the sober, conservative members of the Association, showing that he was uneasy about Mr. Bailey. He belongs to a fishing club—this gentleman—and he showed me just how he could look, and Mr. Fitch and Mr. Sloan could look, when they were off on a fishing party and came in sight of a trout brook on the road, and suddenly seeing a sign reading, “Fishing not allowed on these premises.” If you could have seen their countenances you would say that was as good as any feast that Delmonico ever gave. But it was not for that that I alluded to the cards which have been passed around—particularly of the sketch of Mr. Fitch, whose knees showed they needed stiffening. Those gentlemen tell me that once in Maine they got on a train, and as they entered the car they were immediately attracted by seeing the back of a man in which you could read that he was intensely absorbed in the business in hand. (Laughter). It was evident, if any man in the world knew what a flush was, the man who had that back knew what it was. The man on the other side of the table was a more innocent-looking man. He looked very much like a New York jeweler. (Laughter and applause). He looked like one of these men that knew the difference between rough diamonds and cut diamonds. Still it was evident that on his face there was anxiety and care, and that originated from a desire to learn what his opponent was going to do. Well, the fishermen concluded that they would go over and see who it was who was giving this man so much misery. Fishermen, you know, are friendly to everybody and thing except fish. They wanted to find out who this back belonged to. Now, this is not to be told, but Bailey was the man who had the back. (Loud laughter). Mr. Bailey at this time gave a good illustration of wrestling with competition. But as to fishing. What is it that interests people, after all, in fishing? The interest is all culminating at the critical moment; there is a worm there that happens to have a hook in him, and a man at the other end of the line, and, as is usual in competition, one side happens to get pulled out, either the fish or the fisherman, but it is generally the man who gets the trout.

Well, there is competition in a great many things in these days. There is at this time great competition going on between the dudes of the world, and now I have heard that there are too many in this country, and that the English dude must go because the Yankee doodle-do. (Laughter and applause) I ask my reverend neighbor what he thinks about this, and he says, “I think that that will do it.” I am glad that he has that feeling about it, and that he is not disposed to be vexed with me, and to cuss and to swear about it, because I got that from him, and I am very glad to know that he is amiable under the circumstances, and that he is not disposed to abuse me, and will not curse to the last day of his life, which, however, would not be as bad as that man of whom I have heard who was the most precocious illustration of infantile profanity that is on record. I refer to Job, who cursed the day that he was born. (Laughter).

I pause a moment after that, because I observe that Judge Davis was asking where the point of that was. He asked Tiffany, and that reminds me of my theme, competition. At the bar one of the greatest troubles we have is to make the Judge see the point. (Laughter). I think that one of the greatest benefits that can result in the maintenance of the New York Jewelers' Association will be the teaching, in this inadvertent and unimportant way, that it behooves the Judge to be wide awake because the point may get away from him, for after all there have been such things known as some one connected with the jewelers' trade getting before the Oyer and Terminer (and the Chief Justice in this city presides at the Oyer and Terminer). And from this time on let us all feel that if the Court will learn the lesson of seeing where the laugh comes in it will see where the wisdom comes in.

I suppose that there have been more things said in this square, well-proportioned and neatly decorated room—said in the way of pleasantries—there have been more good things said in this way, and without even a word of bitterness, but touching on politics, touching on theology, touching on philosophy, touching on individuals, than have been said when the undertaking was from the pulpit or the platform. When the faces of the handsome company are rosy like the curtain of June, when there was something passing around the tables, and the spirit of humor pervaded everything. I have heard the best things said on these occasions that ever I have heard said in the city of New York, and I have heard every man in New York who was worth listening to. I tell you that at some associations, like this, when the burgundy has come in and the fun has started, the best things that ever I have heard in New York are said. (Applause).

PRESIDENT BROWN—We have letters of regret from Hon. Carl Schurz, Hon. William M. Evarts, Hon. Chauncey M. Depew, Gen. Horace Porter, Thomas N. McCarter, James H. Goldey, Actuary of the Hardware Board of Trade, and Otto Young, President of the Chicago Jewelers' Association.

I will now give you the next regular toast of the evening:

"Our annual festival; A good dinner lubricates business."

It is hardly worth while for me to introduce to you the Hon. Isaac H. Bailey. (Cheers of greeting).

ADDRESS OF HON. I. H. BAILEY.

Mr. President and Gentlemen of the New York Jewelers' Association:

I am very sorry that I have been called at this stage of the evening, because I am unwilling to produce any feeling of sadness in this company, and it is quite impossible for me, under the circumstances, to produce any other feeling. (Laughter). My peace of mind was destroyed in the opening remarks of the Chairman when he alluded to my calling, and I felt at that time, and have felt ever since, like a poor relation at a Christmas feast. Gentlemen, I do not think that I should be disturbed, but since we are on this matter I may as well remind you that I represent an interest which is financially depressed, and that the only trade gatherings that I am permitted to enjoy, except the annual dinners of the Jewelers' Association, are meetings at which there are no refreshments (laughter); are meetings in which the menu consists of a schedule of liabilities and extremely limited assets; at meetings where every man is as sad as I am to-night in memory of it, and where there is a disposition to frown down any attempt at humor, if such an attempt should be made. Now, gentlemen, you can understand how a man coming from such associations feels in a presence like this, surrounded by luxuries which are altogether unknown to him except when he can enjoy them here; participating in festivities which he can by no possibility reciprocate unless he should have a much better credit with the jewelers than I have ever succeeded in getting. It is a painful subject, and it is therefore necessary that I should call your attention to the misery of your fellow beings who are largely occupied in finding out what dividends they can get out of the unfortunate credits they have been engaging in. If you can, under these circumstances, find anything out you are an exceptional class. I dare say a good many of the misfortunes of these creditors have been the result of indulging too freely in the luxuries of your trade. But if we could only find some of the precious stones which have been laid aside for a rainy day by these people. Unfortunately it is of the nature of portable property which we cannot find. But after the matter has been settled and the creditor discharged, these jewels will be returned to you.

I was very much struck with the opening remarks of my friend, Mr. Sullivan, on the subject of competition—struck with them because it seemed to me that Mr. Sullivan was introducing subjects here with which none of us were acquainted. He began by alluding to the drinking at different parts of the tables. As there has been no drinking at my part of the table, I naturally conclude that Mr. Sullivan is in such a condition that he sees double. (Laughter). Then Mr. Sullivan introduced something about cards—poker. I do not suppose any of you know what that means. I did hear something about the exploits of three fishermen out there in Maine—I did not happen to be in the party—but I understand that my friend Sloan, who lately launched into the matrimonial world, did perform an exploit that was not put down in the books, and when my friend Sullivan alluded to him as a man who is friendly to everything except fish, he ought to have exempted loons, for I am told that Sloan poured many shots into a poor loon up there. (Laughter).

Now I must confess for my own part that I have had some new acquaintances with jewelers since the last meeting—our friend from Chicago, Mr. Matson, for instance, and I understand that there they have Kings in the jewelers' trade. But I think that the most interesting gentleman in the jewelers' trade I have met lately was a gentleman from New Haven, Mr. Ford. Now, gentlemen, if you have never seen Ford go to New Haven, New Haven is thought to be notable only as a classical spot, but Ford has got jewels there equal to any place in the world. Now, gentlemen, I am very sorry that the peculiar circumstances under which I have been brought here have compelled me to say that I am very sorry that I cannot share in your felicity, but I want to say that I feel that I have been under the ministrations of Dr. Paxton, and can contemplate your prosperity without envy, and I tell you that as long as I am invited to attend your annual dinners I shall come. (Applause).

PRESIDENT BROWN—The next regular toast is:

"Citizenship; Whatever makes men good Christians makes them good citizens."

Dr. Wilbur F. Watkins will respond to this toast.

ADDRESS OF REV. DR. WATKINS.

Mr. President and Gentlemen of the Jewelers' Association:

It gives me, I assure you, no ordinary pleasure to be present at your annual banquet this evening, and to respond in terms which, whether fitting or not, I can promise you, shall be few to the sentiment which has just been proposed. I am not left to select a theme, but one is assigned to me by the courtesy of your Committee, and one which, perhaps, had I had my own selection, would have hardly been ventured upon, because it seems to me dangerously in the order of a text, and there is very great peril, therefore, that, true to the ruling passion, I may fall into a spirit of sermonizing, which would be quite out of place here.

If I were to allow myself to wander at all from the text for a moment I might refer to some of the remarks that have been made by the distinguished friend at my side (Mr. Sullivan). It has afforded me, I may say, very great gratification to observe what an admirable specimen of the good seed sown in good ground my friend is; for some of the remarks that I made incidentally in the course of the evening were incorporated in the course of his remarks, and I quite agree with Mr. Tiffany that they constituted the best part of

his speech. (Laughter). But, gentlemen, I think it a good thing that the business men of New York—those representing so large and so honorable and so useful a branch of industry as the members of this Association—should recognize the relation which my profession has for all secular interests, a relationship which has not been always sufficiently recognized. I think we have not mingled as often as we ought to have done. I will not presume to say on which side the burden of the blame rests, but I am quite willing to assume, as the representative of my profession, our full share of blame. It has been too commonly assumed that the men of the ministry, and the things for which they contend, have no special interest in or connection with affairs and men of affairs, and men of my profession and yours, therefore, instead of meeting and mingling, have looked askance at each other. Perhaps the best opportunities we have for looking at each other without prejudice is to come to the social board. It has been assumed that there is no compatibility between spiritual things and the things which you represent. A great veil has been drawn between the temple and the market place—a veil which is impassable. Many men suppose the principles of Christianity not compatible with commercial success, leave their religion outside of the place of business, and never dream of taking it with them to the counter or the office. And men of my cloth have fancied if they came into too close contact with men and things it would not be safe, and have dwelt aloof by themselves. I have no sympathy with any such high churches as that. The time has been, and it is passing away, I think, when that course has been regarded as the proper thing. In olden times the Puritan strove to make religion an austere thing, and, as a consequence, having no dealings with secular matters, he took to hunting down Quakers and burning witches as a pastime.

But I remember that the theme that I have to speak to is the relation between Christianity and good citizenship. We are all citizens of no mean city—I mean most of us—there are some few unfortunate persons here, I believe, who are not citizens of New York; but I will not say anything that will add to the poignancy of their grief. As citizens of no mean city we will take it that that which underlies our prosperity is Christian principle. If you were to bring a stranger here what would you point him to as proof of the greatness of New York—this Queen of the West, admired as she is seen by the eyes of all the people of the earth? Not the magnificent mansions of our millionaires, not the buildings which hold the beauty of the art and industry of the world, not Wall street with its exchanges and brokers, and the madness of its operations; but rather, I think, we would point the stranger to those two great institutions, the school house and the church. (Applause.) I have no faith, gentlemen, in the permanence of our institutions that are not rooted and founded on the Rock of Ages, and I take it that the brightest gem which adorns the diadem of this Association is not the diamond or the ruby, but the brilliancy of that star which sparkled in heaven's constellation over the plains of Bethlehem.

While the present condition of our city causes us to hang our heads here in New York, I will not refer to politics, for I know that people are very sensitive about their politics—very much like the person in the time of the war who, in his sympathy with the current feeling for the South, stayed away from church lest his feelings should be hurt on this point by any remarks of the preacher. One day a friend of his sued him to go to church, and so earnest was his friend in his entreaty that at last this man consented to go to church. After the sermon this friend asked him if he was pleased. He replied no, his feelings had been injured. "Why, there was nothing in the sermon about politics," said the friend. He retorted, "There was nothing in the sermon, but in the first prayer the parson prayed that the wickedness of the wicked might come to an end, and didn't he mean the Democratic party?" (Laughter) With such an example as that I will not dare to wound the tenderest conscience here; yet surely, in all seriousness, I may be allowed to say that one of the evils of our time is the fact that our citizens allow national issues to enter the municipal elections, and that the time ought to come, and it must come soon, when good men of both parties will agree to combine in the matters of local interest, not for any other purpose than the selection of the right man for the right place. (Applause). How absurd it is that we should allow party politics to interfere with the elections which control our own local interests. Surely men should rise above partisanship in the matter of local elections. I have already extended these remarks much beyond the point where I intended to stop, but I would like to say before closing that if I were called upon to build the structure which should fitly symbolize the relations of Christianity with good citizenship, I would lay first its foundation in Utility. Upon this should rise in Egyptian proportions—broad, magnificent and firm—columns adding strength and dignity to the structure. These should be surmounted with tabature, supported by arches, which would give beauty and strength to the building. This should represent Sound Government. But above these, adding completeness to the whole, there should rise a magnificent dome, like that of the building in Washington, which I was permitted to see yesterday, lighted up with the last rays of the setting sun, and which, after a five months' absence in Europe, I regard as the grandest building in its beauty the world contains. I say above this structure should rise a dome, radiant with glowing gems, catching the rays of the rising and the setting sun, and crowning everything, proclaiming the coming of the millenium glory, and this should be Christian Principle. I thank you, gentlemen, for the patience and kindness with which you have listened to my remarks. (Applause).

PRESIDENT BROWN—I want to pause a moment now and propose the health of the first President of this Association, Moses G. Baldwin, who is not with us to-night.

The toast was drunk in silence.

PRESIDENT BROWN (*continuing*)—The next regular toast is:

"The Judiciary; Where law ends, tyranny begins."

I have the pleasure of introducing to you the Honorable Judge Davis.

ADDRESS OF JUDGE NOAH DAVIS.

Mr. President and Gentlemen of the New York Jewelers' Association:

My first duty, as it is also my great pleasure, is to tender my thanks to this Association for giving me the opportunity to participate in this excellent dinner. It revives our veneration for that well known toast of the Mohawk Dutchman, who, speaking from the depths of his heart, said: "Nothing tastes so good to a man as what he eats himself." If I had been called to follow Sullivan and Bailey, under the inspiration of apollinaris, I should have given you a temperance speech. Those gentlemen would have furnished me the text, not as examples, but as warnings. (Laughter). I recollect an anecdote of a very distinguished Judge of the Supreme Court of this State, who, before his elevation, was in the habit of becoming elevated in another way. His friends thought his promotion would operate as a cure for his failing, but the Judgeship does not always cure vices, and this honorable man could not always refrain from his nips, and so his friends waited upon him, and one said: "Judge, now that you are on the bench, we think it your duty to be an example in the community." "Example, sir," said he, "I am no example, by Jove, I am a warning." And so I could have used my friends, as they turned State's evidence against each other, but I forbear; for the good sermon that has intervened has produced emotions which lead me in a little different direction. I must, however, say a word to my friend Sullivan, who complains that the courts do not see his points. He forgets that at the bar—in court—he does not sit with a half-dozen bottles before him, and does not talk under the inspiration of champagne, and, more than that, he never has the Rev. Dr. Watkins by his side to help him. (Laughter). Unfortunately, when he appears at the bar he has the misfortune of producing insomnia on the bench, the result of which is that his criticism is true—his points are not easily to be seen. (Renewed laughter). And as to my friend Bailey, why I wouldn't, without a sense of pain, make any allusion to his indulgence here to-night, a pleasure which he seems to have been deprived of for some time before. His speech reminded me of those old lines which you will pardon me for quoting:

"Pity the soul of a poor old tanner,
Whose trembling limbs have brought him to your door;
He knows himself what is the matter with Hannah,
And don't seem to know much more."

But to pass these things which do not seem to have much to do with my text—and I will confess that I am very much in the condition of clergymen—some clergymen—who are in the habit of giving out a text with an emphasis which impresses the congregation with the idea that there is really no other text in the Bible but that, and yet, when the sermon is closed, leaves the conviction that, after all, doubtless, there is no text of that sort in the Bible. I am afraid you will get that impression of my toast. What was the toast, Mr. President? (Laughter. The President repeats the toast). I presume that is so. I don't know what kind of law it alludes to. (Laughter). Does it allude to the law of fashion? Well, tyranny does not allude to her, for the law of fashion produces the tyranny of jewelers. There is no body of men in the community I think so subject to the laws of fashion, and yet so powerful to create them, as the jewelers. Here is my friend Tiffany; if he should set himself about establishing the fashion for ladies to wear a silver bangle in the nose, in thirty days half of New York—the ladies I mean—would appear in the streets with such a bangle over their mouths and chins. But that is a species of tyranny that the jewelers would begin when the law ends, for no bangle could hang from a woman's nose without being opposed by the law, which prohibits any interference with the osculatory pleasures of the masculine portion of mankind, and in defence of this law there would be a speedy insurrection. Now, as to the law of time, I see a gentleman here who, in point of time, can beat Maud S., Jay Eye See, Vanderbilt, or anybody else, and that is my friend Appleton, who can turn out eleven hundred watches a day. He not only supplies the American market, but, as I read recently in an English newspaper, he is absolutely crowding out the English manufacturers. This is the law of trade. But I presume this toast has something to do with the position or occupation which I hold. I will say this, that I am extremely gratified to know that in that branch of the Court which Mr. Sullivan said that I am in the habit of holding—the Oyer and Terminer—it is a rare thing to see a jeweler. I never had a man stand up to receive sentence who gave as his occupation that he was a jeweler. (Applause). I heard a fellow once, in western New York, who was told he would be permitted in prison to follow his usual occupation, claim that he was a stage driver (laughter), but never in my life have I seen a jeweler in that fix. But your President alluded to two classes of the guild with which I am somewhat familiar—the forger for one, and the burglar or plumber, I don't know the difference, for the other. (Laughter and applause). The forger is not at all entitled to be a jeweler, although he turns out some splendid work. Gentlemen, I am proud to be able to say that as far as my administration of the law goes, it has never been my misfortune to meet any of you in any branch of the Court, unless it was in the jury box. There I should like to see you very often. I wish you could sit on the grand jury and investigate for the purpose of finding out where the tyranny of your public officers begins. When they deviate from the path of honesty and begin plundering the public, I earnestly wish that many of you might be called on to discharge the duty of investigation. But, gentlemen, when I got up to talk here, I really had no speech, which I suppose you have discovered by this time. I am glad I came to-night. Although I was disappointed very much to remain away in consequence of what I regarded as a

justifiable excuse, yet I am glad I came to have the privilege of saying these few words, which may make our acquaintance, I hope, more pleasant and agreeable to you as they certainly will to me.

PRESIDENT BROWN—Gentlemen, the next regular toast for the evening is:

"The Jeweler; His imperial fancy has laid all nature under tribute, and has collected riches from every scene of the creation and every walk of art."

I have the pleasure of introducing to you the Rev. John R. Paxton, D. D. Dr. Paxton, after a few apologetic remarks for using notes, said:

ADDRESS OF DR. PAXTON.

Mr. President and Gentlemen of the New York Jewelers' Association:

I am glad enough to do honor to the imperial fancy of the jeweler, which has laid all nature under tribute, and ransacked earth and seas for gems and gold; but what I do not like, am not glad of—indeed, what I complain of—is that the speakers at the annual dinners of your Association in years past have likewise laid history, art, tombs and prehistoric man under tribute; in other words, have exhausted the subject and left nothing new or fresh to be said. There is not a Cyprian collection left me, not one Etruscan tomb, not a memory of Egypt, not even the famous ring of Cheops, and worse than all, Mr. Depew last year left the famous diamond necklace; he did not entertain you with the great suits at law concerning renowned jewels in Europe, his own proper sphere, and encroached on my preserves, stole my thunder, and did not even leave me Demetrius, who surely belonged to my profession. (Laughter). So, too, St. John's picture of the New Jerusalem—a true Jew was he in this respect, that his Oriental imagination was fond of gorgeous colors and resplendent jewels—here even this resource has been denied me; we have already applauded it.

But there is one great name connected with your art, and in my text-book, the Bible, I have failed to see mentioned—and, by the way, you ought to erect an altar to him, name a child for him, call your guild after him, for what Elijah, John the Baptist, and St. Paul are to me, a preacher, Bezaleel, the son of Uri, the son of Hur, of the tribe of Judah, is to you.

Gentlemen, all men who are exceptionally endowed and passionately devoted to their work in the world may be said to be called of God, and inspired to do it, if it is good work and worth being done. In the Bible I read that soldiers and goldsmiths, judges and strong men, as well as prophets and kings, were called of God. The spirit of the Lord came upon Othniel, and he went out to war; came upon Samson, and made him strong; upon Moses, and made him wise; and upon Bezaleel, the son of Uri, and made him a cunning workman. "And the Lord said unto Moses, I have called Bezaleel and filled him with the spirit of God, to devise cunning works, to work in gold and silver and cutting of stones." The Pope of Rome traces his apostolic dignity back to St. Peter. You have yours, not to Solomon, as Free Masons do, but nearer the first man. You are older than Masons, than the Christian Church, for Bezaleel, who built and adorned the Tabernacle in the wilderness, was your original jeweler, and directly inspired of God; so I put you down among the holy and inspired callings of men. You got your commission from God. Bezaleel is your patron saint, your tutelary deity, your craft god, for he was inspired by the spirit of God to embellish the tabernacle, and held his commission from God equal with Moses and Joshua. I propose his name for honorary membership, and will gladly join you in drinking to his glorious memory—the first inspired goldsmith. (Applause). Gentlemen, in the division of labor of the world it has fallen to your lot to embellish, beautify and adorn the world. Many men rise up in history whose mission, it seems, has been to conquer the world—Cæsar, Alexander, Napoleon; other men rise up who advance the world—Pythagoras, Plato, Bacon and Newton; others to enrich the world with essays and dramas and cathedrals. Your mission is to adorn the world, and in the prosecution of this noble task your imperial fancy has searched the bottom of Indian seas for pearls, you have ransacked the ends of the earth and dug deep in her bowels for diamonds, you have left no nook or corner unexplored where a possible chance existed of finding a precious stone or a bit of gold. Therefore we honor you as among the benefactors of your fellow men. Scientists seek to make human life increasingly useful and safe. You seek to adorn and to beautify homes, society and the individual, and, after all is said, ornamentation comes first, utility second. I once gave a negro woman a dollar to buy bread. I saw her soon after with a flaming bandana on her head. She went hungry to feed her love of ornament. Some things, some trades, some callings are outgrown—left behind in the march of progress; but the jeweler came in before history began to be written, is still here, and will remain to the end of time, and possibly be in demand in heaven if the apocalyptic vision of St. John be true to the facts. For the love of ornament is planted in the constitution of human nature. There have been tribes found without religion or law; people exist who do not know morals or anything that belongs to civilized society; but no tribe, or clan, or barbarous people have yet been found who did not practice the art of adornment, according to his light and ability—the Indian in paint and feathers, the African with rings in his nose, teeth of elephants and claws of beasts strung over his body. Yes, you have hold of mankind by its strongest, in short, most universal trait or disposition, the love of adornment. Some people won't have a doctor, others will not go to law, others never come to church, but the man and woman is not yet found who does not pay tribute to your art in some way or other. And nobly have you responded to this inborn love of ornament in man. Your genius and fancy and

research have taxed the whole world as Cæsar did. You have studied botany more closely than those who are professors of it; you have ransacked the natural world for your models and conceits; you have outdone Cesnola and Schliemann in research into ancient history, and out of the ruins of time dug the treasures of the dead ages to serve or make for your production. (Applause). It used to be said that to read the New York *Tribune* or the *Times* was a liberal education for a man who had not the good fortune to go to college in his early life, or who lived in the benighted towns of the country, remote from this great and glorious metropolis. And truth in it there is, I think. But it may be sincerely said that Tiffany's, or Howard's, or Starr's, or a dozen more stores, are a liberal education in the arts, in natural history, in the antique, in the course of progress, in invention and discovery; then in their rich museum you see the duplicate of the ring King Cheops wore, who built the great pyramid; you see fac-similes of the roses that adorned the houses of the Pompeiano; you see enamel finer than any Palissy ever dreamed of; you see shields of silver such as Achilles carried in the siege of Troy; you see drinking cups used in the days of Cæsar in Roman taverns. Then leaving the department devoted to the antique, you can study botany from a delicate fern leaf to an Oscar Wilde sunflower, done in gold or silver; you can see dogs in metals that rival Landseer's creation in canvas, and every bug, or insect, or animal that creeps, crouches, flies or works in all creation. Of a truth, the imperial fancy of the jeweler has laid all nature under tribute, and has reproduced the beauty of every scene of the creation and every work of art. Therefore, I greet the Jewelers' Association as one of the great educational and refining forces or institutions of the modern world. (Applause). We all pay tribute to the jeweler. If we love, he knows it, and shares our joy when we ask to see, carelessly, "some plain gold rings," and then *sotto voce*, "ladies' size." (Laughter). If we have a streak of good fortune in Wall street, or come into an inheritance, the jeweler knows it, for diamond ear rings come before carpets from Sloan's or a carriage from Brewster's. Now a word for you, gentlemen, as American jewelers. What strides you have made in manufactures in ten years! Yankee clocks and watches keep time for all the world. You have driven Manchester and Sheffield out of the markets, and to-day the American eats with his own knife, if he has not the fear of Mr. Arnold in his soul. In art, colors, and nicety of finish and originality of design, in jewelry, in clocks and watches, cutlery and plated ware, you are leading the world. As a patriot I rejoice in that, and wish you enlarged and wider success, and I pray and wish from my heart that you may go on and supply the whole world with the products of taste, skill and invention.

Mr. President, when God made the monkey, a philosopher of France said He must have had a sense of the ridiculous and He meant man to laugh. When God made a lion, He must have had a sense of the terrible. But when God made diamonds, pearls, sapphires, rubies and opals, He must have had a sense of the beautiful, and meant man to wear them, to delight in them, and put them on the breasts of the fair. You in your noble art and calling are thus fulfilling a purpose of God, and my hearty wish and sincere prayer for you all is this: That each of you may build for himself that noblest, grandest, most beautiful and enduring house—a human character, pure, true, good—a character like the gems you work with, made of gold, silver, precious stones, not of wood and hay and stubble, but a fine, true character, that fire cannot consume, nor death destroy, nor eternity wear out—a character that shall endure amid the wreck of matter and the conflagration of a world. (Applause).

PRESIDENT BROWN—Gentlemen, the next toast is:

"The Hub."

"Solid men of Boston banish strong potations,
Solid men of Boston make no long orations."

This toast was intended for Mr. Chauncey M. Depew. We shall have to pass it unless some gentleman from Boston will respond to it.

Mr. Benjamin Shreve was called for, and briefly responded as follows:

Gentlemen: I have only a few words to say. We have redeemed Massachusetts from Butler. As an old resident, I would say that we have a Robinson instead of a Butler, and have reason to rejoice. (Applause).

MR. BROWN—The next toast is:

"Statesmanship; A disposition to preserve, and an ability to improve, taken together, would be the standard of a Statesman."

Hon. Theodore Roosevelt will respond to this sentiment.

ADDRESS OF HON. THEODORE ROOSEVELT.

Mr. President and Gentlemen of the New York Jewelers' Association:

I think any remarks upon Statesmanship in New York will sound a little like the famous chapter upon "Snakes in Ireland," which read: "There are no snakes in Ireland." Dr. Watkins spoke of the many magnificent buildings that this city has, of the many things that we have to be proud of, of the many things that distinguished us from other cities, but I think he omitted reference to our most unique institution—our Board of Aldermen—the wise Aldermen, the unutterably preposterous Aldermen, our ridiculous Aldermen. (Laughter). Certainly there is nothing like our Board of Aldermen. Now, gentlemen, having excellent examples in some which have spoken before me, I will not stick to my text. I have been warned here that one must not speak of politics, but, judging from the aspect of the table, there is one party I think I can attack, and that is the Prohibitionists. (Laughter) About two years ago, my brother and myself went

out to Iowa to shoot prairie chickens. We reached our shooting grounds on Thursday. It rained all that day, all Friday, and all Saturday; Sunday was a very bright day. No church was within twenty miles of us, but there were lots of prairie chickens. Our morality held out beautifully until about ten o'clock, A. M., when we sallied forth with guns on our shoulders. Toward the end of the day I felt rather repentant—my ammunition was about exhausted—and thought we ought to do something to strike a kind of average, so I suggested that we have some hymns in the evening. There was one lady in the house where we stopped who cooked for us—and I have always considered it a special dispensation of Providence that I survived her cooking. When we had gathered together our books, my brother asked this pastoral lady: "Are you a soprano?" and she replied, to our astonishment: No, sir; I was raised a Methodist, but I have been to the Baptist church recently." (Laughter). Now, gentlemen, the only application of that story is, that having been asked to speak to Statesmanship, I am going to speak of the preliminaries instead. I must say that I think the respectable citizens, and nobody else, are to blame for the present condition of affairs in New York as regards politics. It has come to be rather a discreditable thing to take any share in politics in this city, either at the primaries or at the polls. Just before election, the other day, a friend of mine remarked to me that the condition of the city was perfectly scandalous, and yet when I asked him to come to the polls and work on election day, he replied that he was going quail shooting, and could not do it. I will take the liberty of telling you a little story that I heard the other night. During the late war, at a cotton blockade, an officer was stationed at a certain point at which the cotton had accumulated very largely. One day he found a check for ten thousand dollars in his desk. He read it and tore it up. A week went by and cotton was still more valuable, and he received another check for twenty thousand dollars. He wrote to the man who sent the check if he received anything more like that he would arrest him. Shortly after that he received a check for twenty-five thousand dollars, and he telegraphed to Washington to be relieved. No notice was taken of his request. Ten days after that he received a check for thirty thousand dollars, and he forthwith telegraphed on to Washington: "I must be relieved at all hazards, it is getting too damned near my price." (Laughter). While a portion of our public men will serve disinterestedly, the majority of them want their figure to induce them to assist their country. Until respectable citizens will see that they are represented by honest men, there will be very little chance in being able to speak of statesmanship in New York City.

PRESIDENT BROWN—Gentlemen, the next regular toast is:

"Woman; She is adorned amply that in her husband's eye looks lovely, the truest mirror that an honest wife can see her beauty in."

I have the pleasure of introducing to you R. G. Rolston, Esq.

ADDRESS OF MR. R. G. ROLSTON.

Mr. President and Gentlemen of the New York Jewelers' Association:

When I heard the remarks made by my esteemed friend, Mr. Sullivan, I felt that his words were very true, for there was great competition at this end of the table at any rate. So great a competition that the friend upon my right, the Honorable Mr. Roosevelt, was obliged to leave the room in order that the rest of us might catch up with him—and we did. It reminded me, in consequence of the exertion which was made, of the story which I heard of the negro whose master supposed that he had not gone to church, and wanted to reprimand him for it. He said to him, "Sambo, you didn't go to church to-day." "Oh, yes, massa," Sambo replied, "I was at church." "Well, what was the text?" "It wuz—it wuz de miracle of de five towsand loaves and five towsand fishes that war fed to the apostles." "Well, sir," said the master, "I do not see any miracle in that." "Oh, yes, massa," said Sambo; "de miracle was that dose apostles didn't bust." And that is the miracle here to-night.

You can imagine how surprised I was to-night when I learned that I was to respond to the toast of woman, a theme which scholars and sages of all nations and in all ages have dwelt upon, and all with signal failure. And for me, not a speaker, to be placed in such a position was, I assure you, a great surprise, a surprise equal to that of the statesman who went to the office of the county clerk and said, "Me name is Mallony. I conthrol thirty votes in the ward. Me cellar is full of wather and I'm afraid that the hins will get dhrowned." The county clerk said that he had nothing to do with that, and advised him to go to the mayor. Reluctantly this statesman left the office. In a few days he returned again, and the county clerk not recognizing him, said with his customary suavity, "What can I have the pleasure of doing for you?" "Me name is Mallony. I conthrol thirty votes in the ward. Me cellar—" The official interrupted him with, "Why the devil didn't you go to the mayor as I told you?" "Sure, sir, I want to the mayor, and I tohld him that me name was Mallony. I conthrol thirty votes in the ward, and me cellar was full of wather, and I was afraid that the hins would get dhrowned, and he said, well, why the deuced don't you kaap ducks." (Laughter).

But what, Mr. President, was the toast? Woman; she is adorned amply that in her husband's eyes look lovely. Now, the converse. What woman, Mr. President, does not look lovely in her husband's eyes so adorned. You take the golden hair of the blonde, or the rich locks of the brunette, arranged in the artistic skill for which they are so adept; the beautiful, soft neck, the well shaped arms, the tapering fingers, surrounded by emeralds and sapphires and rubies, certainly she looks beautiful in anybody's eyes—except, perhaps, Ben Butler's. But, Mr. President, I think this toast, woman, smacks of the shop, for it seems to me that if it were not for woman, with her tastes and her beautiful desires, you would have been deprived of attending these pleasant occasions for the last nine years,

for I doubt very much if the institution could exist were it not for woman. But, Mr. President, there exists in woman other jewels than those which we get from the earth. There is the pure heart, the desire to please, to help to live, which places her in a position above man. When sickness lays us low what medicine is so soothing as the care of woman; or when adversity draws near what consolation is there like woman's? I have been listening to the remarks made to-night with much interest. The imperial fancy of the jeweler was well set forth with the remarks of the reverend gentleman who responded. I should like to have been introduced to the original jeweler, Bezaleel. [Judge Davis: "He was the son of Hur."] (Laughter). But, gentlemen, I will not detain you longer. I suppose that more speeches are to follow, and will bid you good-night.

PRESIDENT BROWN—Gentlemen, The next regular toast is :

"The Bar; Bold of your worthiness, we single you as our best moving fair solicitor."

I have the pleasure of introducing to you the Counsel for the Association, Mr. E. S. Bartlett.

ADDRESS OF MR. E. S. BARTLETT.

Mr. President and Gentlemen of the New York Jewelers' Association :

In responding to the toast of "The Bar," one should feel quite at his ease in this presence. You have manifested on this occasion, and upon others, a disposition to practice at the Bar in a way that would have astonished Kent and Blackstone, and that is calculated to convince the ordinary legal luminary that you are "bone of his bone, and flesh of his flesh." The artists may seek to claim you as their particular patrons by reason of your frequent purchases of *Bar reliefs*, yet, after all, your kinship to the legal profession is at least cousin-german. With this relationship existing, it ought not to be difficult to interest you in things legal, and to engage you at once in the contemplation of those great principles of natural justice that underlie the superstructure of the State, and society in general. But, before starting in, as I shall soon do, upon a very lengthy essay on the rights of persons, the rights of things and the law of contingent remainders, I have a bone to pick with you, and we might just as well stop here as anywhere and have it out.

Layman-like, you have imbibed the prejudices of the world at large—the generation in which you live, and class lawyers—mentally, at least, if you do not confess it before men, with the plague, pestilence, famine and all the other "ills that flesh is heir to." You associate the payment of their fees with those of the undertaker and doctor, and count it an evil day when you are enrolled in the noble army of plaintiffs or defendants. Now, it would be an easy task to convince you that all this is a sad mistake, and a wicked persecution of the greatest benefactors of mankind.

History lies open before us, and we have but to draw from its inexhaustible supply of facts, figures and arguments to satisfy you that you have been led to a false conclusion, and that gross injustice has been done to a learned and honorable profession. But this course would involve considerable mental effort on our part, and as a profession we lawyers have resolved on a line of action quite as effectual and far less fatiguing. All things come to him who can but wait. Now, statistics have established one great fact that may well cause your cheeks to blanch, and your pocket-books to close convulsively. This fact, unfortunately for you, is as fixed as the law of gravitation or the precession of the equinoxes, and it is this: All the estates on Manhattan Island pass through the Surrogate's office at least once in every thirty-three years, and many of them much oftener.

Now an estate always has to be assisted through the process of probate. It matters not how able the Surrogate may be—he may have the learning and the executive ability of the learned Chief Justice who now does me the honor to listen to these remarks—yet attorney and counsel must be called in, and a large percentage of your estates finds its way into the pockets of the long-suffering and much-abused lawyers. There is something beautiful to contemplate in this inexorable law of nature that can thus right a wrong with a certainty that is truly refreshing. The lawyer can say to all who misrepresent him: "I bide my time."

That we are justified in thus revenging ourselves is demonstrated by all literature. In the drama and the novel we have been compelled to sit in the stocks of public opinion, while you made merry at our expense. Dickens never wearied in "going for us," as the boys say, and you have laughed with the rest of mankind over Dodson & Fogg and their proceedings in the leading case of *Bardell vs. Pickwick*, wherein their exploits have been handed down to us. You have also, in common with others, formed your estimate of our profession from Tulkington in "Bleak House," Sampson Brass in "Old Curiosity Shop," and Jagers in "Great Expectations."

I doubt not, however, that Dickens, like yourselves, had underneath his broad caricatures a genuine respect for all that which was worthy of admiration in the legal profession. We can forgive him much, on our part, when he accompanies his attack with such delicious humor as is found in the scene between Blow and Bumble in "Oliver Twist." You will recall, Bumble had been present when his wife destroyed certain trinkets, and Blow assured him he was the guiltier of the two, as in the eye of the law Bumble's wife acted under his directions. Bumble said: "If the law supposes that the law is an ass—an idiot. If that is the eye of the law, the law is a bachelor, and the worst I can wish the law is that his eye may be opened by experience." As I yet linger in the shining ranks of the bachelors, I am led to infer from this bit of revelation—this confession of a benedict made frank by exasperation—that in the marriage state there has been a reversal of the old judgment rendered by Lord Coke that "man and wife are one, and the man is that one." It is painfully evident that Puffendorf has it otherwise, I

doubt not our friend Bumble would have appreciated the story of the old Quaker who was traveling through the country with his wife, she being mounted on a large, fine-looking horse, while he rode a little runt of a pony. A man by the way accosted the Quaker, saying he did not understand how he could be content to ride the pony while his wife had the large horse. The Quaker responded: "Friend, when thee is married thee wilt know." The Quaker would have seen the force of the recent newspaper squib stating that in a certain foreign locality college students were allowed two wives each. The narrator adds this is the local mode of hazing.

After all, what we read in the literature of the past, what we hear in the current opinion of the present reflecting upon the law and its disciples, is aimed only at its abuses and excrescences, and is really most friendly criticism. As one of the humblest members of that priesthood who minister at the altar of justice, and who stand evermore in the presence of her whose hand holds aloft the impartial scales, and whose eyes are blinded that she may perceive neither friend nor foe, I should be recreant to the high trust imposed on me did I not declare in this presence, and in every presence, that to be a lawyer of standing at the Bar is to be a man of the highest integrity—the most undoubted probity. And why should it not be so? The lawyer has ever before him the impressive lessons of his professional experience, and he of all men realizes that it is only possible for the State to exist in its perfection when its foundations rest upon those great legal principles which have been established by the wisdom of the fathers, and when the Courts administer the law with firmness, with ability, with absolute purity.

Common law is said to be common sense, and in no country under the sun has there been a sturdier development of that characteristic than here, where the blood of the Puritan, the Huguenot and the Dutch runs in the veins of a race that may point to their fair land and exclaim with England's laureate:

"There the common sense of most shall hold a fretful realm in awe,
And the kindly earth shall slumber lapt in universal law."

(Applause).

PRESIDENT BROWN—Gentlemen, the last toast of the evening is our

"Guests and Customers; You have come with us to be our guests; you will give us joy, and we will do all in our power to honor you."

I don't see the gentleman that was to reply to this toast, so you will please to select some one yourself. (Cries for Dodd. Mr. Dodd responded by calling upon Mr. Wilkinson).

MR. WILKINSON—Gentlemen, you surely cannot mean me. I didn't come here to speak, but to listen. There are other gentlemen here that are better able to speak to this toast than I. In fact I have nothing to say about our customers. Those of them that I see here to-night are, I am happy to say, men of remarkable intelligence. But there is one thing I would like to have said. As a representative body there is one thing that we ought to do. With us at present there are gentlemen assembled who are employers of perhaps twenty thousand men. This large number of men should be instructed in the artistic manufacture of jewelry for your benefit, and for the benefit of the community at large. I ask, what are we doing to that end? The reply comes, nothing. Our duty is to put ourselves into condition whereby this Association shall be a power in the education of our workmen for the better furtherance of our trade. (Applause). It is uncomfortable to consider that we are standing still and permitting ourselves to float on, failing to do what it is our duty to do. (Applause).

PRESIDENT BROWN—Gentlemen, the time has come for us to separate. I hope you have all enjoyed yourselves as I have, and I bid you good-night, trusting that good digestion may wait on appetite, and health on both.

On the Road.

CINCINNATI, Nov. 20, 1883.

To the Editor:—Leaving New York last week for a short trip through the country, I have stopped at various places and visited the trade, with the view of getting the expression of dealers as to the general outlook. In Philadelphia I found the trade complaining of present dullness, but sanguine that the aggregate of the year's business would compare favorably with that of last year. They have had no special rushes of orders, but business has been coming to them in a steadier flow and more even volume. I found considerable interest manifested in the exploits of a young man of elegant appearance and good address who has run a brief and brilliant career as a swindler in this city under the name of Benjamin A. Johnston. He assumed to be a junior member of the firm of Adam Johnston & Son, of the Franklin Iron Works, Reading, Pa., and secured a diamond ring from J. E. Caldwell & Co. on a check bearing the forged

signature of the Reading firm, and a cluster scarf pin from Bailey, Banks & Biddle on a similar check. The piano manufacturing firm of Schomacker & Co. was called on by the same young man on the same day that the jewelers were victimized, from whom he ordered a piano for \$500. On the following day a letter was received by the firm, directing the piano to be got ready for shipment immediately. In the meantime the piano firm had written to Reading, and had received a letter from the genuine firm of Johnston & Son, in which they disclaimed all knowledge of or connection with Benjamin A. Johnston, and the piano was not shipped. He attempted to swindle other firms, but failed and then fled. A lot of bank checks signed by Adam Johnston & Co. have been found in the Schuylkill River, near Gray's Ferry Bridge, which are supposed to have been thrown from the car window when the swindler was leaving the city. No steps for his arrest have been taken.

From Philadelphia I "skipped" to Pittsburg, which I found as smoky as ever, but manifesting considerable business activity. Pittsburg is a live, active, thriving and growing place, and whoever picks it up for a sleepy customer will "get left." Here I met the traveling missionaries in full force; they are as busy as bees, and if they do not give good accounts of their labors, it will not be their fault, for they are certainly industrious and persevering, never losing an opportunity to catch a customer. They report business generally as fair, but by no means "booming." Retail dealers buy in only limited quantities, but express confidence in a fair year's business. The travelers have to work all the harder when business is dull to keep up their average, and if any one thinks it a pleasant thing to be "on the road," they are respectfully invited to come and try it. I have called on the dealers in Pittsburg very generally, and find they are a live, enterprising class of men, keenly alive to all that is going on, and ready at all times to take advantage of whatever novelties come up in their line. Hodge, Slemmons & Co. have just published a very complete price list of American movements, cases, tools, materials, etc., which they design for the legitimate trade. Wm. D. Smith has just patented an alarm for an eight-day clock, which is one of the best things that has been brought out lately. The old house of G. B. Barrett & Co. is doing a large business, and all hands are kept busy, while Goddard, Hill & Co. are pressing along with more enterprise than ever. The following circular, which was handed me here, meets the approval of all dealers:

WALTHAM, MASS., November, 1883.

To the Employés:—Dealing in our watches on the part of the employés has come to such proportions and is so great an interference and injury to our interests that we can no longer allow it. The retail traders throughout New England are constantly complaining that they are undersold by our own factory hands, and many of them have, in consequence, become disaffected to us and have abandoned the trade in our goods. They are in many cases led to believe that our hands get their supplies direct from us, that the goods so supplied are selected watches and better than the regular manufacture, and that the trade is carried on with our approval. And the watches being bought from jobbers are in fact sold at retail for about the price retailers are obliged themselves to pay. All this tends not only to the direct injury of our business, but brings us into disrepute. It is very properly resented by the legitimate retailers, who have a right to feel that the Company, so far from encouraging such an illegitimate business, should protect them against it. Our employés at the factory, like the clerks in our agent's offices, who are forbidden to buy or sell a watch for private profit, are hired to assist the Company in its operations, and should not interfere with and demoralize its market. We therefore call upon every one in our employ who has been engaged in this business, to abandon it. We feel sure we have but to make the request of all those who are loyal to the Company, and would wish to advance the interests by which we all live, in order to secure a ready and cheerful compliance.

R. E. ROBBINS, *Treasurer.*

From Pittsburg to Cincinnati is but a short ride, and coming over with Ben Ellison, President of the New York Jewelers' Club, made the distance seem much shorter. Ellison is one of the most popular travelers who visits the West, and as entertaining as he is popular. The picture gallery he carries in his pocket, embracing as it

does many portraits of the royal family, is an interesting compilation, but it costs money to understand it as Ben explains it. If I have to draw on you from here it will be because the instructions given me by Ben have exceeded the limits of my pocket-book. If Pittsburg is a busy place, Cincinnati is doubly so. There seems to be a diversity of opinion as to the catalogue schemes, some dealers being in favor and others opposed to it. Clemens Hellebush has issued the following circular to the trade:—

In answer to the many requests received by me for illustrated catalogues of jewelry, I would say that I do not, nor have I ever, issued any, believing it detrimental to the legitimate jewelry trade. Their former promiscuous distribution has been the cause of great dissatisfaction among the jewelers, as they so often found their way into the hands of firms and individuals not entitled to them. *Another point!* It takes fully six months (after a pattern has already been put on the market) to get up an illustrated catalogue, and by the time it is even ready for distribution, the designs and patterns are so ancient that no wide-awake jeweler would dream of having them. My aim has been, and will be, to keep the trade constantly supplied with the newest and latest patterns and designs put on the market, and which will fill the requirements of the trade. I shall at all times take great pleasure in sending out packages on selection to such parties furnishing good and undoubted references. I am confident that the legitimate and wide-awake jeweler will bear me out in the assertion that all jewelry selected from catalogues should be purchased in *job lots* to suit the purchaser.

The fact that Mr. Hellebush is now doing a larger business than ever is an indication that the trade endorses the position he has taken.

The Dueber Watch Case Company is driven with business, and are working incessantly to their fullest capacity. They are overwhelmed with orders for their new filled cases, and it seems impossible for them to catch up with them. The company advertises "Dueber silver cases," and recently a country dealer wrote to know what "Dueber silver" is. He was informed that it was simply sterling silver, which is the standard in the manufacture of Dueber cases.

Lodwick & Nolting have recently issued a very neat catalogue, containing illustrations of everything in the watch, clock and jewelry business. It is very neatly arranged and does not expose prices, a feature that retail dealers will appreciate.

A. & J. Plaut, the "wide-awake jewelers," as they are called here, in addition to carrying a general line of watches and jewelry, make a specialty of masonic emblems.

Business generally in the city seems good, and the trade, although not jubilant, is satisfied and hopeful. I am off for Chicago to night.

J. W. S.

Proceedings of the Horological Club.

A DISTINGUISHED BODY OF WATCH AND CLOCK MAKERS.

One hundred and fourteenth discussion.—Communicated by the Secretary.

[NOTICE.—Correspondents should write all letters intended for the Club separate from any other business matters, and headed "Secretary of the Horological Club." Direct the envelope to D. H. Hopkinson, Esq. Write only on one side of the paper, state the points briefly, mail as early as possible, as it must be received here not later than the eighth day of the month, in order to be discussed and reported in the CIRCULAR for the next month.

ABOUT 18-KARAT GOLD AGAIN.

Secretary of Horological Club:

In the November number of THE CIRCULAR, page 324, a jeweler of Providence corrects the author of "Advice to Watchmakers' Apprentices," in regard to alloying 18 k. gold, and, as he is not exactly correct, it is no more than right he should be corrected. The amount of alloy to be added to a twenty-dollar gold coin should be 34.4 grains of silver and 68.8 grains copper. As he gives 38.7 grains silver and 64.5 grains copper, it might "mislead some." I have taken a deep interest in the aforesaid articles. I have just completed a

punch-press as described in the June number, and I am much pleased with it. I have used quite a number, but none I like as well.

DUDLEY L. TICE.

Mr. Rolliver said he was glad to notice the general desire for correctness. There was nothing in the world like being correct. He might even say that correctness was the only thing that was correct, or ever by any possibility could be correct. By all means let us have a correction of whatever is not correct. He hoped our friends would persevere in correcting whatever was incorrect, until they had got everything corrected up correctly. Then he believed he would take a hand in himself, and correct the whole lot.

RUBBER WATCH PROTECTORS.

Mr. W. F. A. Woodcock, of Cumberland, Md., sends to the Club samples of a very ingenious protector for openface Swiss watches, or any thin openface watches. It consists of an elastic rubber cap or bag, arranged to entirely cover the back and edge, and reach down somewhat over the dial. The rim has a band of thicker rubber, to allow for wear, etc. There is also a hole in the rim for the stem. It is apparently pulled down over the stem, then the bag is drawn over the case, when it contracts again, and encloses the whole of the watch, except the interior of the dial and the pendant bow. For those who are liable to get water in their watches, or who perspire so freely as to blacken the cases of their watches, this would be very convenient and useful. We infer that Mr. W. sells them, although he does not say so, nor does he name the cost of them.

LARGE STREET TIMEPIECES.

Secretary of Horological Club:

With this I take the liberty to send you a photograph of my new street timepiece, representing a *large gold openface stemwinder*. It is of my own construction and my own make, and I don't think you have seen one like this before. The full height is $5\frac{1}{2}$ feet, case 42 inches, dial 34 inches, and the thickness only 7 inches. The hands are so balanced, invisibly, that an 8-day American clock (drop octagon) drives it. I improved the escapement, and it varied during the last four weeks $\frac{1}{2}$ m. slow. The hands are from ebony wood. The dial is drawn on paper by myself. The time can be seen very distinctly as far as you can see the dial, and the time is correct on both sides at the figures 3, 6, 9, 12 inside of $\frac{1}{2}$ minute. The big watch is of course perfectly water tight. It proved itself so thus far, as we had during the last 8 weeks several rainy nights and days, and I hope it will do the same in the future. Would be pleased to hear from you, what you think about it.

ADOLPH STAIB, Practical Watchmaker.

Baltimore, Md., Oct. 15, 1883.

Mr. Clerkenwell regretted that Mr. Staib did not send us a wood-cut of his watch sign, for it was really a handsome piece of work, judging from the photograph. As such a sign would be very desirable for many watchmakers, in both city and country, we would be pleased to receive a description of how the clock works are arranged, to make them drive the hands correctly on both sides of the sign-watch. Are the hands outside, exposed to the weather, or covered by glass? If the former is the case, it evidently would not answer for our northern winters—but that point could, of course, be added wherever necessary. If it seemed practicable, this kind of street watch would perhaps be made by many of our readers, and full particulars might therefore be very interesting to them.

IMPORTANT DISCOVERIES BY A WATCHMAKER AND MEMBER OF THE CLUB.

The Chairman then said that he desired to congratulate the Club upon the rising reputation of one of its members. He was pleased to observe that our talented friend, Mr. CHARLES E. FRITTS, of this city, is earning a European fame for his inventions in electrical matters. He had noticed, a few days ago, an article of the same import as the one below, in a German exchange, and the English periodical, *Engineering*, of Oct. 19, says that "At a recent meeting of the American Association for the Advancement of Science, Professor Mendenhall announced the formation of selenium cells of very low resistance by Mr. C. E. FRITTS, of New York. Low resistance

selenium cells are a *desideratum*, and Mr. Fritts' cells, the full construction of which was not explained by Professor Mendenhall, attain their end by means of large surfaces of selenium, instead of narrower surfaces, as in the older cells. Another peculiarity, which involves a new observation, is that the light in the Fritts cell is allowed to fall on the selenium in the same direction as the electric current passes, and not at right angles to the direction of the current. This is a very important point, demanding further investigation, and, now that selenium can be manufactured more cheaply, it will probably be largely experimented with. The cells of Mr. Fritts can be made 9 to 10 ohms. resistance. They can, moreover, be easily repaired on breaking down."

He sincerely hoped that this highly valuable invention would, beside the well-merited honor, bring to Mr. FRITTS an adequate recompense in the shape of "filthy lucre." But he was particularly pleased to recall that it was upon his motion that Mr. Fritts had been elected an honorary member of the club several years ago. The old members would remember his articles upon the chronometer balance, the compensation of pendulums in fine regulators, and other subjects, showing him to be well versed in the science and practice of horology. For some years our pages frequently contained suggestive and well-considered articles from his pen, which were highly valued by the trade throughout the country. But latterly his name did not appear in THE CIRCULAR, and, whenever urged to contribute, his reply was, "Too busy to write." It was understood that he was working at some electrical inventions, but he did not seem to care about making it known, saying that some time his work would speak for him. It appears to be speaking now, and, judging from what is said in the technical journals, in very complimentary terms. He did not understand electricity, and therefore did not clearly comprehend the exact nature of Mr. Fritts' discoveries. But he believed that Mr. Electrode, who was an expert in that science, and well acquainted with Mr. Fritts, could inform us upon that point, and suggested that he should do so. First, however, he would again express his gratification that it was one of our own members that was the author of these inventions, and a former follower of our craft. Although he no longer follows it, practically, we still claim the right to rejoice in his successes and good fame, as those of "one of us."

Mr. Electrode then explained to the Club that selenium is a metalloid, which has the singular property of changing its electrical conductivity under the action of light. This remarkable attribute has been known for about ten years, and during that time has been experimented with by many, if not most, of the leading electricians and scientists, so that that field has been considered pretty well worked over—in fact, worked out. But, notwithstanding the duty and labor expended upon it, the substance showed itself so inconstant and unreliable as to be utterly unmanageable for any practical purpose, and selenium cells were consequently dropped out of use, and generally regarded as of very little real value for actual work, or even for scientific research.

When, about two years ago, Mr. Fritts established his electrical laboratory and experimental rooms in this city, for the purpose of practically developing some inventions of his own, he determined to find the cause of the anomalous behavior of selenium, well knowing that, if its action could be made uniform, it would at once be utilized in every department of electrical science, both technical and theoretical.

With the thoroughness which characterizes his work, he began at the beginning, and studied the chemical purification of the substance. He succeeded in separating the product into portions having properties so distinct from each other as to lead to the conclusion that ordinary selenium is not a simple element, as supposed, but a compound, consisting of different allotropic forms, or else of selenium and some new element yet unknown. This point will doubtless attract the attention of chemists everywhere as soon as his results are published.

Having devised an entirely new form of selenium cells, and constructed them with the selenium of his preparation, he proceeded to investigate its properties. He naturally experimented first with its behavior in light, and obtained results which almost pass belief. The most sensitive cell ever made, heretofore, was one by Dr. Werner Siemens, of Germany, who probably has no superior as an electrician. His cell had about fifteen times as much conductivity in sunlight as in dark, while Mr. Fritts has produced cells which had *more than eighty times* as much! It seems hardly credible that so great a change could be possible in the conductivity of a substance, simply from exposure to sunlight, yet several of our most eminent scientists have called at his laboratory and become convinced, and are taking a deep interest in his work.

Nor did he stop there, but went on making original discovery after discovery, all in the supposed worked-out field, and he says the end is not yet. It would not be necessary to describe his later results, as they could only be comprehended by electricians, but they are of a nature so surprising and unexpected that we may anticipate very important modifications in the present accepted ideas concerning electrical conductivity and resistance. Some of these discoveries will shortly be announced in the leading scientific journals, and will doubtless make quite a stir in scientific circles, both here and abroad.

The investigation of the properties of selenium is, however, only a small part of the work which Mr. Fritts has been carrying on. As his other experiments relate to the practical development of inventions not yet patented, particulars concerning them are not vouchsafed to visitors—in fact, visitors are only allowed, at all, in exceptional cases. But enough is already known of his work to entitle him to an honorable rank among the scientific discoverers of the day. We watchmakers feel a pardonable pride in the fact that our ranks have contributed not a few of the names enrolled upon the annals of fame, and those of us who are acquainted with Mr. Fritts' thorough mastery of whatever he undertakes, and his thoroughness, industry and perseverance in working it out, may well hope that, if his health is spared, he will yet make a record not inferior to any of those who have gone before him.

How to Make and Engrave Silver Bangles.

BY EXPERT.

FROSTED or matted silver and gold grounds for bangles is very popular; by ground I mean after the dime or gold coin is polished the surface is frosted by means of a scratch brush, or some other method, thus leaving a frosted or matted surface on the metal, on which bright cutting shows to great advantage. To do this with a scratch brush requires a high velocity of the lathe, and more particularly a steady motion or rate of speed, for which a foot lathe is not well adapted. A small machine standing about 5 inches high for doing such work is shown at fig. 1. It is not difficult to make and is very useful to a watchmaker or jeweler, as it frosts watch plates, stem-winding wheels or jewelry works, and for laying mezzotint grounds cannot be equaled. An elevation of the machine is shown at fig. 2; this is a side view, and shows the general form very well. The principle on which it roughens the face of the coin or other metal surface is by means of steel points so arranged that they vibrate back and forth with an intense velocity, each point striking the metal about 8,000 to 10,000 times in one minute. To understand the principle, we will suppose that fig. 1 at *a a* shows the longitudinal section of a tube, and *A* a pointed solid cylinder laying in it; we will first assume that we apply our mouth to the end of the tube at *C* and suck, the pointed cylindrical piece *A* will be drawn back until it strikes the stud *b*. Now, by alternate sucking and blowing the piece *A* would vibrate back and forth between the stud *b* and the object *d*. To utilize this idea, we construct a cylinder

with a piston to alternately exhaust or suck and blow, and also provide an arrangement so that when the object *d* is removed the point *A* cannot be ejected from the tube. The machine stands on a piece of $\frac{1}{2}$ -inch board 5 or 6 inches square, shown at *F*. The piece *D* can be of cast brass and shaped as shown in fig. 2. At *E* is shown an edge or side view in the direction of the arrow *c*. This piece should be about $\frac{3}{8}$ thick when first cast, so that when finished up it will be a trifle over $\frac{1}{8}$ of an inch thick. The piece *D* has a base, shown at *e*, fig. 1 (and also in the edge view at *E*), for fastening to the base board *F*; this base has four holes for screws as shown. There are two other flanges (shown at *f f* in the same cuts) for fastening the plate *G*, to which the cylinder *H* and the pulley *I* are secured. This plate *G* should be about $\frac{1}{8}$ of an inch thick, and serves as a bed piece to fasten the working parts of the machine to. As the driving power will generally be supplied from the foot wheel which drives a lathe, we have assumed that the pulley *I* is about 5 inches above the bench. The writer presumes that nine-tenths of his readers who may wish to construct such a frosting device will either use a jeweler's polishing lathe or a watchmaker's foot lathe; consequently a height of about 5 inches will answer for

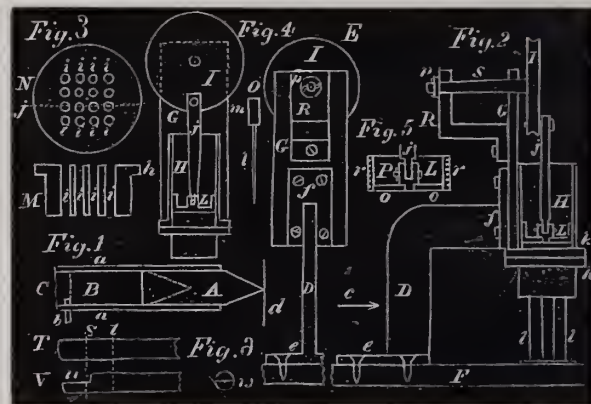

both. If you use a counter shaft on your bench, you can connect the pulley *I* directly with it; or if your band runs directly from the foot wheel to the lathe, you can use the spindle of your lathe as a counter-shaft. For such persons as are exclusively engravers, a train of gear wheels turning by hand would answer the best; but in such an arrangement the last transfer of power to the pulley *I* should be by a band. A train of about four wheels would answer; but it is imperative that the pulley *I* should revolve from 100 to 150 times a second. For reference sake we will give the sizes for most of the parts and say that fig. 2 is $\frac{1}{3}$ the real size, though other cuts of parts may be larger or smaller than this. The cylinder *H* is one and one-half inches long, and can be made of a piece of brass tube $\frac{3}{4}$ of an inch inside diameter. The kind of tube to use is seamless, and is drawn on a mandril and perfectly smooth and true on the inside. The lower end of the tube should have a flange or ring soldered on to it with soft solder for securing the box holding the vibrating points. This box is shown at fig. 3, where *M* is a vertical section and *N* a top view; it should be made of cast brass $\frac{5}{8}$ of an inch deep, measured in the direction of the cylinder *H*, to which it is attached by screws. This piece is pierced with 16 holes, as shown at *N*, fig. 3; as *M* is a vertical section, it only shows 4 of these holes at *i i i i*. These holes should be about $\frac{1}{16}$ of an inch in diameter, and each provided with a plunger or vibrator. One of these plungers or vibrators is shown separate at *O, l* representing a No. 8 sewing needle, and *m* a plug of metal (brass or steel). These plugs should be $\frac{3}{8}$ of an inch long, and turned to fit holes *i* as close as possible consistent with moving easily. I would say here that the writer never used any pieces *m* which worked as well as those turned up of ivory and drilled to receive the needle *l*. The reader should understand that the idea is that these pieces, working in the holes shown at *i*, work up and down every time the piston *L* moves up and down. There are some more of the details of these parts which must be spoken of subsequently; but it is better for the present to speak of the other parts of the machine. The upright plate *G*, fig.

4. is 3 inches long and $1\frac{1}{2}$ wide, and secured to the flange f with 4 screws, and is $\frac{3}{8}$ of an inch thick. The manner of arranging the pulley I and arbor S must be evident on inspection, except to say that the arbor S is slightly taper to fit holes broached out in the plate G and cock R , and that the arbor S is held in place by a washer and pin shown at p . A front view is shown at fig. 4, showing how the pulley I and connecting rod J and piston L are connected. The pulley I has several holes into which the screw attaching the connecting rod J and pulley I together can be changed so as to make longer and shorter stroke of the piston L . This is important, as it gives a greater or less energy to the vibrators O . Thus, if we desired to make a coarser surface, *i. e.*, deeper indentations, we would put the screw into hole the giving the greater stroke to the piston; or if we desired to make a lighter or more delicate frosting, we would set the piston to a short stroke. The piston L is of peculiar construction, and is shown separately at fig. 5; the sides shown at $r r$ are made of a short piece of tube which exactly fits the cylinder H ; the piece of tube for a piston should be $\frac{1}{2}$ an inch long in the direction of its axis, and a head o soldered into it as shown; riveted into the disc o is the joint piece P for attaching the piston to the connecting rod J . This joint works on a taper pin with a hole in the end, into which a bent wire is inserted to prevent its working out by the violent shaking it is subjected to. It will be seen that, as the joint in the piston is in its center (considered in all directions), that there will be no tendency to cramp in the cylinder, and that it does away with any necessity for a cross-head. The piece shown in fig. 3 should be carefully drilled, so that the holes will be perfectly straight and true on the inside. In drilling such holes a Morse twist drill is the best, and after the drilling is done the hole should be enlarged and trued out with what machinists term a "hog-nosed" reamer; for the benefit of those who do not know or understand what a hog-nosed reamer is like, we will give a cut of one. A piece of steel wire (in this case) is turned to nearly fit the hole to be enlarged; we will say in this case that the piece should be left $\frac{1}{32}$ of an inch larger. At fig. 6 is shown at T such a reamer as first turned up. There is some skill and judgment required in turning such a reamer; it should taper a trifle from the end to the dotted line s , a true cylinder from s to t , when it should diminish about $\frac{1}{32}$, and then remain a true cylinder the rest of the length. The end at V is half cut away to a little back of the dotted line s , and the cutting edge of the reamer (counting the direction in which the reamer is to turn) is beveled as shown at w . If the holes are carefully drilled and afterward reamed out with such a reamer as just described, the holes i will be, for all practical purposes, perfectly true. It will be necessary to let a portion of the description of this little instrument run into our next.

Imitation Stained Glass.

A PROCESS BY WHICH THE GENUINE ARTICLE IS SUCCESSFULLY COUNTERFEITED.

AMONG the many uses of the printing press none is more novel than the production of imitation stained glass. Designs for any pattern desired are engraved on wood. The blocks of wood are placed on an old-fashioned hand press, and then are inked with oil colors compounded with special reference to the use for which they are intended. Then a sheet of very thin hand-made porous paper is laid on, and a prolonged impression given, in order that the color may thoroughly permeate the paper. Each color is, of course, printed at a separate impression. Having completed the printing process, the different pieces of paper which compose the design are soaked in warm water half an hour, taken out, the water sponged off, and then coated on one side with a thin cement. A similar coat of cement is given the glass to which the paper is to be applied, and then the paper is laid on in place, and varnished over. The plain

glass window becomes at once, to all appearances, a window of stained glass. The effects of the lead lines, the irregular pieces of colored glass, the heads of saints and soldiers, the antique, or the modern Japanese designs are all to be had as brilliant in color as the genuine glass.

"Will the stuff last?" was asked of a Broadway dealer.

"We have had it in all sorts of places, where it was subject to the action of frost, moisture, the direct rays of the sun, and artificial heat for five years. We warrant it for ten years, if the owner of the glass will varnish it as often as he would a piece of furniture."

"Suppose it gets dirty?"

"Use soap and water as you would on any other varnished surface. Its merits are only now becoming known because of a prejudice against imitations, and a fear among some people that the frost will ruin it. But within a year we have applied over 40,000 square feet of it. Our customers include the best Long Branch and Saratoga hotels, owners of new business blocks on Broadway, fashionable churches in New York and Brooklyn, and apartment houses. When the reporter of a Brooklyn paper wrote up one of the churches there as having magnificent new stained glass windows, when, in fact, the old six by nine glass in the old frames had been covered with our paper, we naturally hopped on to the top rail of the fence, flapped our wings and crowed."

"How does the cost compare with genuine glass?"

"It costs about one-tenth as much. We put a large window in a country church for \$11. A real glass window opposite cost \$165. Members of the congregation have assured us that ours is more admired than the other. The cost of decorating a window is 75 cents a foot if we do the work. We will sell the designs, and the parties can put them on at a less cost. Any one can do the work."

Standard Railroad Time.

THE CHANGE of time that went into effect on all the railroads of the country on the 18th ult. completely revolutionizes railroad time, and, generally speaking, the local time in different sections of the country. It will prove a great convenience to all who are much given to railroad traveling, and to business men in general, inasmuch as it gives a fixed standard by which the time can be reckoned very easily. From a horological or legal standpoint the change effects nothing whatever, for the science of horology is based upon exact facts, and is not governed by the arbitrary dictum of any body of men or railroad corporations, and as Congress has not approved the new standard, the old will be maintained in all cases where correct time forms an element of controversy.

The new standard grows out of the confusion occasioned by the numerous railroads operating on time reckoned from different meridians. It required unanimous action on their part to effect a change, and this was obtained at a meeting of railroad representatives held in Chicago last spring. Mr. Allen, identified with the "Official Railway Guide," was largely instrumental in securing the adoption of the plan. It consists in the division of the continent into five time belts, each of fifteen degrees in width, and in each of which the time is to be the same from its eastern to its western boundary. The division time is that of its central meridian; and thus five standards, each differing from that of the contiguous territory by exactly one hour, will serve the entire country. Practically, but four will be used in the United States. Minutes and seconds are thrown out of the reckoning, and on the roads adopting the plan no change of time will be made of more or less than one hour between one point and another. The advantage to them in the simplification of time tables and the preparation of running schedules is appreciable at a glance. It will save about as much time as the adoption of phonetic spelling would to one attempting to learn the English language. To that small fraction of the public which

uses the railroads seldom or never, of course it is immaterial whether the change is made or not. But the millions who do use them have but to ascertain railroad time at any given point and then keep the boundary lines of the division fixed in mind, in order to be absolutely sure of accurate railroad time in any portion of the country. The marking of these lines by a broad band on the maps usually found upon time tables, which will probably be made, will facilitate the process of learning where the hands are to be set backward or forward one hour.

Following is a clear showing of the territory embraced in the five divisions, which any one can easily trace upon a map:

The intercolonial division begins at the sixtieth meridian, a short distance east of the extreme limit of Nova Scotia, and extends about two degrees west of the seventieth meridian, Quebec, Canada, being on the dividing line between the intercolonial and eastern divisions. The intercolonial embraces Nova Scotia, New Brunswick, a portion of the province of Quebec, and a small section of Northern Maine. Intercolonial time is based upon the sixtieth meridian, and is one hour faster than eastern time.

The eastern division takes in the States of South Carolina, North Carolina and Virginia (excepting a small slice off the southwestern corner of each), West Virginia, Maryland, Delaware, District of Columbia, Pennsylvania (excepting a very narrow western strip), New York, Rhode Island, Connecticut, Massachusetts, Vermont, New Hampshire, Maine (excepting a bit of northern territory), and that portion of Canada between lines drawn due north and south through Quebec, and almost due north from Detroit through Sault Ste Marie. Eastern time is based upon the seventy-fifth meridian, which is an hour slower than intercolonial time, or four minutes slower than New York city solar time.

The Central division takes in Manitoba to the western limit defined by a line drawn due north of Fort Clarke, Dak., and an eastern limit defined by a line drawn almost due north of Sault Ste Marie, Mich.; all that portion of Dakota west of a line drawn almost due north and south through Fort Clarke and Bismarck; the States of Minnesota, Wisconsin, Michigan, Iowa, Illinois, Indiana, Ohio; a very small western fraction of Pennsylvania; Kentucky, Tennessee, Georgia, Florida, Alabama, Mississippi, Louisiana, Arkansas, Missouri, the Indian Territory, three fourths of Nebraska, the whole of Kansas (excepting a small northwestern corner), the State of Texas, excepting a few miles of territory off the northwestern corner. Some of the prominent cities in the central division are: St. Paul, Minneapolis, Chicago, St. Louis, Indianapolis, Cincinnati, Milwaukee, Louisville, Detroit, New Orleans, Memphis, Kansas City, Cleveland, Omaha and Toledo. Central time is based upon that of the ninetieth meridian, which is one hour slower than eastern division time.

The Mountain division embraces all that portion of British Columbia lying west of the borders of Manitoba, and east of the one hundred and fifteenth meridian (or Mount Head); that portion of Dakota west of a line drawn north and south through Fort Sully and Bismarck; one-fourth of the western portion of Nebraska; small portions off the northwestern corners of Kansas and Texas; about two-thirds of Lower California—the southern section; Arizona (excepting a very small western slice); New Mexico (excepting a cut off the southwestern corner); Colorado, Wyoming, Montana (excepting a small piece off the extreme northwestern corner); the southwestern portion of Idaho—about one-third the territory; Utah (excepting a small cut-off on the northwestern corner). Mountain time is based on the one hundred and fifth meridian, and is one hour slower than central time, and two hours slower than eastern division time.

The Pacific division includes that portion of British Columbia west of Mount Head on the one hundred and fifteenth meridian; Washington Territory and all the northern and western portion of Idaho, Oregon, California, Nevada, a portion of the northwestern

section of Utah, the northern part of Lower California. Pacific time is based up on the one hundred and twentieth meridian, and is one hour slower than Mountain time, two hours slower than Central, and three hours slower than Eastern.

Following the example of the railroads, most of the cities and villages have changed their local time to correspond with the railroad standard—that is to say, the time of the central meridian in each division is adopted as the standard time throughout the entire division. We can conceive how many perplexities are to arise out of this arbitrary method of reckoning local time. For instance, when it is precisely noon on the 90th meridian it will be 12.30 at the eastern limit of the central division and 11:30 at the western limit; yet by this arbitrary decree it is to be 12 o'clock everywhere within the division. We can conceive of many legal complications that might arise under this arrangement. For instance, where property was destroyed by fire at noon of the standard time, and the policy covering it expired at noon, the insuring company might refuse to pay the loss, when, by actual local time, the policy would have some minutes to run—sufficient time, in fact, to make the loss the company's rather than the individual's. But Congress has not yet legalized this change, and, consequently, exact local time will be recognized by the courts in any litigation where the question of exact time forms a material feature of the controversy. The new standard will be a great convenience for all persons who are at all dependent upon the railroads, but horologists, who view the matter from a scientific standpoint, will scarcely relish a change that ignores exactness, and substitutes therefor the arbitrary dictum of railway officials.

James M. Smith, of Gibsonville, says the *North Carolina Patriot*, while ploughing on his farm, turned up an irregular-shaped, smooth-faced stone, the size of a hen's egg, which he took to a Greensboro jeweler, who pronounced it a genuine emerald. The jeweler was also of the opinion that smaller crystals clinging to the center stone were diamonds. These alleged facts created considerable interest among jewelers and mineralogists, and is said to have induced a diamond miner who visited Mr. Smith to offer him \$1,000 for the stone, which he unwisely refused. Mr. Smith, thinking that he had a veritable bonanza, brought the stone on to New York, and intrusted it to Mr. R. W. Donnell, a banker, who took it to Mr. G. F. Kunz, the well-known expert of Tiffany & Co., for examination, and his report of this alleged gem was read before the meeting of the New York Academy of Sciences, October 22. Mr. Kunz said that after subjecting the stone to various tests, he found it to be a crystal of quartz, penetrated by long, hair-like crystals of green actinolite or byssolite, and containing strings of small cavities filled with liquid. It was only valuable as a mineralogical specimen for cabinet purposes, and was worth for such use about \$5. The report was accepted, and the crystal was returned to Mr. Donnell, to be sent back to the expectant Mr. Smith. At the same meeting of the Academy, Mr. Kunz reported on the "Georgia Marvel," or the "Blue Ridge Sapphire," as it is called, which was found a little over a year ago in a brook in that State. The stone weighed about half an ounce, and was supposed to be worth about \$50,000. This valuation is alleged to have been placed upon it by Prof. Dana, who, as a matter of fact, had never seen it. The discovery of this stone, and the romance surrounding it, created even greater interest than did that of the North Carolina emerald. So much so that two well-known Southern jewelers did not hesitate to declare it a genuine stone. Consequently, it was forwarded to this city for a crucial test. Mr. Kunz, after a brief examination, found it to be a piece of blue bottle glass which had been rolled in the brook until the action of the water and gravel had effaced all marks of the bottle, and had imparted a natural sapphire appearance.

Problems in the Detached Lever Escapement.

BY DETENT.

WE HAVE NOW arrived at the fork and roller action of our escapement, and it would be well for at least the younger members of the fraternity of watchmakers to give this subject careful thought and attention, for there is no portion of the lever escapement that so often suffers at the hands of the botch—*cross-roads watchmaker—soft solder artist*—as the fork of the lever. He opens wide the banking pins, files the fork into the shape of a swallow's tail, and then, after all this work and attention, wonders what the dickens is the reason the watch does not have a better motion. He next applies the universal panacea for such cases—of watches with poor motion—puts in a four-horse power mainspring; and if the watch goes until it gets into the pocket of the customer he heaves a sigh of relief, and thinks he is about the only man living who could have made a timepiece of such a watch. There has been a good deal of discussion with the craft in regard to which is the best, a long or short lever. By a long or short lever I mean the length from the pallet staff to the roller table, or roller, as it is more correctly termed. It must be understood that a longer lever necessitates the use of a larger roller. We stated early in these articles that we should assume ten degrees as the extent of pallet (and consequently fork) action, and thirty degrees of roller action; so we will proceed to lay out our fork and roller, taking three times the length of the pallet arms as the length of our fork, although there is no reason for this except it is a convenient number. The principal objection urged against a short fork is that if it is so short as to necessitate the axis of the pallet staff coming under the balance, it follows that we must use a short pallet staff in all $\frac{3}{4}$ plate watches; but this surely is no valid objection if the work is well and accurately done; and a lever twice the length of the pallet arms, if the pivots to the pallet staff are closely fitted to good jewels, will perform well. The great object to work for in all watches is a light train. This will be more evident if we stop to think how often the entire inertia of the weight of the train has got to be overcome. Let us analyze the action of a lever escapement: We will suppose a tooth rests on one of the pallets, and the jewel pin enters the fork and unlocks the tooth from the locking face of the pallet; as we have shown, there is a *draw* to the locking face of the pallet, consequently, in the act of unlocking the scape wheel will have to make a retrograde motion; very slight, it is true, but still it is a backward motion, and every particle of matter composing the train has to be aroused from a state of repose, moved backward even to the extreme inner end of the mainspring every time the escapement is unlocked. After the tooth is freed from the locking face, the energy of the mainspring has to force the train forward in time for the tooth just freed to act on the impulse face of the pallet and impart a certain amount of force to the balance. The action just considered explains or answers a query made in a former article of why it was that we would often find the impulse face of English lever pallets pitted a short distance from the angle formed by the meeting of the impulse and locking face, as shown in fig. 1, where *A* represents the pallet, *b* a tooth, *a* the position where we generally find a pit worn. It is evident on inspection that, as the pallet moves away in the act of unlocking, the scape wheel retrogrades, and after the tooth is actually free from the locking face, it takes an appreciable time to overcome, not only the inertia of the train, but an actual reverse motion. To make it still plainer, we will take the motions involved in their order, the direction being indicated by the arrows, and the order by the numerals, *i. e.*, 1st motion of the pallet indicated by arrow 1; this produces retrograde motion of the tooth *b*, indicated by arrow 2; motion 3d, indicated by arrow 3, is produced by the mainspring, but it does not overcome motion 2 until motion 1 has carried the pallet so far away that the tooth *b* strikes the pallet at the point indicated at *a*.

We will now consider the roller action in conjunction with pallet action, as they modify each other in no small degree. At fig. 2 is shown a roller and fork. For the present we will only consider the actions involved, but subsequently we will give the formula for drawing the fork and roller correctly. It is of course understood that the unlocking or opening of the escapement is produced by the action of the jewel pin in the fork, and in this problem the motion indicated by arrow 4, fig. 2, acting on one of the prongs of the fork shown at *d*, is simultaneous with the motion indicated by arrow 1, fig. 1. In fig. 2 the jewel pin *c* engages the fork prong *d*, and carries the fork forward in the direction of arrow 5, for 2 degrees of pallet and fork action. Now, according to theory (as some persons would say), the pallet should be unlocked, for, if you will consult the last number of this journal, you will see we designed the locking face to embrace two degrees of the ten of pallet action. At this point the tooth should commence to act on the incline of the impulse face; but, in actual fact, it does not commence until the jewel pin has carried the fork some distance farther. The dotted lines *k l*, fig. 2, indicate the two degrees of pallet action, and when the fork arrived at *l* the tooth should commence to carry the fork forward, but in actual practice, the fork is carried forward to the dotted line *m* before the tooth commences to act—or, in other words, when the jewel pin has

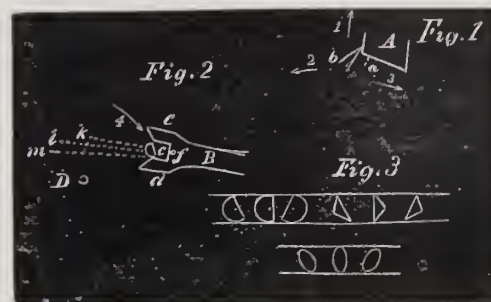

carried the fork forward to *m*, fig. 2, the tooth *b* has arrived at *a* on the impulse face of the pallet *A*. And not even now does the actual act of impulse commence; for there must be a small side shake to the jewel pin in the fork, and also a small side shake in the pivots to the pallet staff; and it is only after all these discounts that the real work of impulse commences. When we give the method of drawing the fork we will give the exact form for the prongs. A few words on the form of jewel pins. The best form is the one shown in fig. 2, which is a cylinder with $\frac{2}{3}$ ths cut away; this gives a free entrance to the fork, and, being a circle, presents always the same diameter to the slot in the fork. At fig. 3 is shown the round jewel pin with $\frac{2}{3}$ ths cut away; it will be seen it fills the space from line to line, whether oblique or otherwise, while the oval and triangular jewel pins have side shake in the fork except when the jewel pin is on the line of centers. In regard to the proportion of size of the balance to the scape wheel, this has, as well as the proportionate length of lever mentioned above, been the subject of much discussion. But if we establish certain grounds or premises for our investigations we can only arrive at one conclusion. To illustrate, let us ask and answer a few questions bearing on the question. In making an escapement, what is it we wish to accomplish? It is plainly this: We desire to control our train in a regular manner, so that it will indicate correct intervals of time. In pocket watches what has been found to be the best governing or controlling power? A balance and pendulum spring. What are the elements or principles involved in the balance and pendulum spring? The answer to this question can be given in this way: A balance and pendulum spring should be considered as the antagonism of two equal forces employed against each other, with a mechanical device which alternately gives one an advantage over the other, thus perpetuating the struggle for mastery. Or, in other words, the momentum of the balance (put in motion) is checked by the force of the pendulum spring, this force being again

imparted to the balance on its return vibration. We must defer our consideration of balance diameter to our next article, as we are full up to our allotted space, and our editor is too just not to let all stars shine according to their magnitude, even to a sixth order, like the writer, perhaps

Advice to Watchmakers' Apprentices.

BY A MAN WHO HAS SPENT TWENTY YEARS AT THE BENCH

IN casting many articles of gold, charcoal is superior to any method, as it can be carved into almost any form. The kind of charcoal to use is willow coal; it is soft, close grained and does not split and snap like many coals; the next best is bass-wood. As an illustration of work which can be done in casting in charcoal, we will take a ring and carry it through the process of casting. It is not to be understood that this is the best or only way to make such a ring, for to nine-tenths of my readers it is much better and cheaper to buy them already made by those who make a specialty of such work. Still there are many jobbing jewelers who would like to make a ring for themselves, or if not very busy make one to sell, for it is a poor employment which is not better than being idle. In this illustration, we will suppose it is a box top ring for a cameo or similar stone. The lower part (shank) is cast nearly straight and afterward bent to suit the finger. We will take a good-sized piece of charcoal and saw it in half, then lay a piece of fine sand paper on a piece of plate glass and rub the sawn face of the two bits of coal until they come flat together; a few rubs together makes a perfect joint. We next lay out the form of the lower part of our ring, shaped as shown at *A*, fig. 1; the

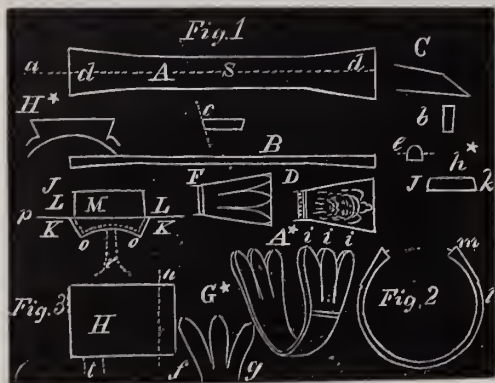

instrument to use in recessing the coal is a flat bottom graver shaped as shown at *C**, *b* being a cross-section of the graver. The entire outline should be cut around with a keen thin point of a knife blade to insure safety from splintering. The ends at *dd* can be cut out to facilitate subsequent ornaments, as shown at *DF*. A little, or rather a good deal of care can well be spent on the carving of such molds; for, if two precautions are observed, the castings can be produced very perfect. The first of these are to heat the coal before casting up to about 400° F., and the second is to have the inlet by which the metal is poured deep enough to produce pressure of the metal sufficient to fill every interstice of the mold. A soft camel's hair pencil should be used to brush away the dust; but it is well to not be too particular about removing all the dust; some can be left remaining to fill the pores of the coal. A caution should be given in regard to cutting the outline with the knife point; the cutting should be done with a knife held nearly perpendicular, about at the angle shown at the dotted line at *c*, fig. 1, where a cross-section of *A* is shown. In selecting ornaments for ends like *DF*, judgment should be used to select such as will finish readily into good shapes. Suppose such an end as *F* is chosen; if the three ornaments (call them leaves if you will) at the end are intended to be convex, as shown at *c*, although it is quite easy to cut such forms into the charcoal mold, still when it comes to finishing in the metal it will be found difficult, except by swedging; and for this reason it is better for an end of this form to give some indications of the form in the casting; but leave the ends

to be finished after the piece is bent, as shown in fig. 2. It can now be twisted until in the form shown in diagram *A**, when the ends can be sawn, as shown at *iii*, diagram *A**, by spreading these pieces, as shown at *G**; the edges can now be filed and beveled, leaving the outer edges at *gf* to be finished after the digits are bent back. In finishing all such work, the edges can be filed and cut with gravers; and, although imperfect in form, still if the broad flat surface is finely lapped and polished the imperfections in the beveled edges are not noticed. Of course it is understood that all file marks are to be stoned and burnished out, leaving the edge comparatively true and smooth. To illustrate what I mean, we will suppose that diagram *N** is an enlarged cross-section of one of the pieces *i*, diagram *A**. The edges *kj* can be imperfect in form if only bright, while the surface *h* should be dead flat and perfect by lapping and polishing. The portion of the ring from *l* to *m*, fig. 2, is best made flat for lapping, a process we will speak of subsequently. In casting the box or setting for the stone more skill will be required. We proceed in preparing our two pieces of coal as before directed, and unite the two pieces with large dressing pins for steady pins, so that they can be taken apart and joined again in exactly the same position to each other. Our next work is to recess into one of the pieces of coal a sink of the shape and form of our box top, as shown at *H*, fig. 3. At diagram *J** is shown a vertical section of *H* on the line *n*; the curved line *oo* corresponding to the curved line *o* in diagram *H**; the line *p* is supposed to represent the line on which the two pieces of charcoal join. In this diagram (*J**) *L* and *K* represent the two pieces of coal, and *oo* the recess or sink or the shape of the box top to be cast. The dotted line above *oo* shows the thickness we wish to cast the box. We could hardly attach a piece of coal to the surface of *L* which would form or fashion the inside of the box; consequently, we recess the piece of coal represented by *L*, as shown at *M*, and insert a block as shown at *M*. To transfer the exact form of the box, mold recesses into *K*; to *L* we can put some dry whiting or plaster of paris into the recess in *K*, into which we are going to cast one box top. Not enough whiting or plaster should be used to entirely fill the recess—say about half fill it. The upper piece of coal, *L*, should now be united to *K* by the steady pins mentioned above. Care should be used in joining the pieces *L* and *K* so that none of the whiting or plaster get out of the recess. After the two pieces *L* and *K* are joined, gently shake the united pieces, and replace them (as shown) so that *K* shall be below. Now remove *L* upward, and on inspection of the surface you will find a perfect outline of the recess in *K*. We now mortise out *L* for the piece *M* (diagram *J**) and curve it so it will leave the space shown at *oo*, diagram *J**. Good judgment, with a few measurements, will generally tell how much to reduce *M* so as to leave the right amount of space to be filled in with the melted metal. A good idea can be got by forming the inlet *r* by which the metal is to be poured, and reverse the mold from the position shown (turning it over), and fill the inlet with dry plaster of paris, when, by gentle tapping, the plaster will fill the space at *oo*, and on taking *L* and *K* apart a good idea can be got of the thickness and form of the subsequent casting. But, if good judgment is used, this last-mentioned test can be dispensed with. In casting the part shown in fig. 1, the inlet through which the metal is poured should connect near the center (*s*), and this inlet should be between the two pieces of coal. The same course can be pursued with the box top; the inlet can be at *t*, fig. 3. Such parts of rings can be cast in sand or fine pumice stone, as directed in former article, but it would require a metal pattern in such cases, whereas, with charcoal, the form can be cut out in the coal; as, for instance, an antique head, as shown at *D*. Such a head can be carved in coal very easily to a fair degree of perfection, leaving the graver and chasing tools to add the final finishing touches. For such work, the portion on which the head (or similar ornament) is to be wrought should be cast concave on the inside so as to need no bending. A few trials of something simpler in casting in charcoal molds will give the experimenter confidence as well as practice.

Foreign Gossip.

—THE INTERNATIONAL EXHIBITION at Amsterdam closed on the 15th of October.

NEW PEARL BEDS.—Reports say that pearls of a magnificent quality have lately been found in the Gulf of Mexico; one weighed 75 karats, and sold for \$14,000.

LISBON EXHIBITION POSTPONED.—Lisbon, Portugal, intended to hold an exhibition this year, but things not moving with that celerity we are accustomed to see here with us, it has postponed the interesting show until May 2, 1884, at which time, it is hoped, the buildings will have been erected.

DENSE STATE OF IGNORANCE.—An exchange says that a Kabyle woman's jewelry belongs entirely to herself, and cannot be claimed by her husband in case of divorce. Naturally she is extremely particular about its shape and quality.

The above is an additional reason why we should be thankful for the high state of civilization we enjoy.

CALCUTTA EXHIBITION.—India will open its exhibition at Calcutta, December 4, 1883. The ceremony will be performed by the Viceroy, and the Duke and Duchess of Connaught will leave England in the beginning of November, to be present. Various native princes, all the principal English officers, as well as the Governors of Bombay and Madras, have accepted the Viceroy's invitation to be present.

REVIVAL OF ANCIENT METAL WORK.—Vice-Consul di Zuccato states that the ancient art of fusing metals which flourished at Venice in the time of the Renaissance, has been revived in Italy with great success. Thirteen factories are now producing, after ancient models, artistic bronzes, candelabras, plates, swords, armor, etchings, chiseled work, etc. There is a considerable demand for these articles for foreign as well as for home sale.

—Three exquisite little statues of bronze and silver have been found at Pompeii. They belonged to a set of seven on the steps of a private altar in a dwelling. One had been removed. The others are an Apollo with the lyre, a Mercury to which the clothing and attributes of Æsculapius had been given after being finished, a Hercules, another Mercury, and two Lares. Some are coated with the patina produced by long burial, and are sapphire blue.

DECIMAL WATCHES.—The sanguinary old *sans culottes* of the French Revolution, not content with decimating the heads of the nobility, went so far in their hatred to all established institutions that they also sought to decimate old Father Time, obliterate all traces of the seventh day of rest as prescribed by the Christian religion, etc. They caused a quantity of watches to be made dividing time according to the decimal system, and the *Revue Chronométrique* says that the Marquis Turgot possesses a number of them showing ten hours, each at one hundred minutes and seconds.

THE WORLD MOVES.—Things must have come to a pretty pass if the staid English *Horological Journal* depreciates home institutions and prefers the method pursued in Hamburg for testing chronometers. It says that "the practice pursued at Hamburg closely resembles that at Greenwich, with two or three exceptions. At the former the trial is divided into periods of ten days each, instead of a week, as at the latter; then, at Hamburg, the chronometers are subjected gradually to the high temperature by movements of five degrees C. This is a more natural arrangement than taking them suddenly from the ordinary temperature to almost the highest extreme, and is more favorable to the chronometers, which are sure to be a little unsteady with sudden alteration of temperature, because the balance spring is sooner effected than the mass of the balance, if for no other reason. There is another point rather in favor of the chronometers at Hamburg. The range of temperature (5 to 30 deg. C.) is known to the adjuster beforehand, who avails himself of this knowledge in preparing his instrument for trials." Verily, the British lion is losing his grip!

RAPID INCREASE IN VALUE.—A suit of armor which once belonged to King Francis I. of France (1494 to 1547), was purchased by Sir Anthony Rothschild for \$500, and sold to Lord Ashburnham for \$5,000. This gentleman sold it to an antiquarian for \$20,000, who, on the same day, sold it again for \$85,000. It was exposed in the Museum of Antiquities in London, which was destroyed by fire, and the armor was buried under the débris. When the spot was cleared, the armor was sold to a junk dealer for old iron. He subjected it to a renovating process, after which it was bought by a Mr. Spitzer, of Paris, for \$60,000, who is at present offering it for sale at \$100,000.

GRAVITY BAROMETER.—We learn from the *Comptes Rendus* that M. Mascart has invented a barometer in which the variations of weight are shown and measured by the changes of height in a column of mercury which is in equilibrium with the pressure of a mass of gas. The instrument has been tested under shocks of every kind to which it would be exposed in traveling in Paris, Hamburg, Stockholm, Drontheim, and Tromsö. It was found to be readily transportable, and its precision did not appear to be inferior to that of the pendulum. It requires no other observation than that of the temperature and the level of the mercury, and the preparation can be made in less than an hour in a hotel chamber.

A NOVEL COMPASS.—Captain Magnagni has invented a new compass, which has been introduced in the Italian navy. Its needle floats upon a pool of water, tintured with spirits of wine to prevent freezing. The water is contained in a glass vessel, with an elastic bottom to allow its expansion and contraction without breaking the vessel. The needle consists of six bundles of fine magnets, built up of cast ribbon steel, and fixed on a cord. It is inclosed in a hermetically sealed case, which is delicately poised on a brass pivot. The pivot has a sapphire top and a jade point, all highly polished to diminish friction. The advantage of the compass is that the resistance of the water being great to rapid movements, is comparatively slight to slower ones, and hence the ordinary movements of the needle are free enough, whereas those due to sudden shocks from without are resisted, with a consequent steadying of the indications. Tried on board the *Duillo*, it is found that the discharge of a 100-ton gun, or the motion of the screw, does not affect the reading of the compass. The effects of the rolling and pitching of the vessel are also guarded against by suspending the floating case a very little above its center of gravity.

THE WEALTH OF MEXICO.—The French *Revue de la Finance* says that since the conquest of the country by Europeans there has been no cessation of work in the gold and silver mines of Mexico. While it was under Spanish rule—that is, from 1537 to 1821—the value of silver produced exceeded 10,431,348,515 francs, and of gold 343,842,055 francs; but since its independence, dating from 1821 to 1880, the value of silver extracted amounted to 4,503,291,545 francs, and of gold 247,068,930 francs, making the total value of the gold and silver produced in Mexico during the period comprised between the years 1537 and 1880 amount to 15,525,551,045 francs, the average annual production being about 45,300,000 francs. It appears that the State of Chihuahua is the most prolific of the whole of Mexico in precious metals. This State is divided into twenty cantons, in which there are 120 mining districts, with 575 mines, which have been regularly worked since the Spanish conquest. It has been found necessary to suspend work in mines which yield more than three and a half kilograms of silver to the ton of ore, on account of the difficulty experienced in transport and the want of proper machinery. According to the *Revue de la Finance*, it only requires an improved method of extracting and treating the ore to raise Mexico to the first rank among precious metal producing countries—a position which she held previous to the year 1848. It is expected that the completion of the central railway traversing the State of Chihuahua, which is now in course of construction, will materially contribute to the result.

Workshop Notes.

STAMPING ZINC ORNAMENTS.—For stamping zinc ornaments, the sheet zinc is heated to 140 degrees, when it can be stamped.

NEW ALLOY—AROUZOID.—The following new alloy is reported from England as a substitute for silver; it resembles old silver, and works like it: Tin, 4.03; lead, 3.54; copper, 55.78; nickel, 13.41; zinc, 23.20; iron, a trace.

ELECTRO-PLATING IN BRONZE.—To electro-plate in bronze, make a solution composed of 50 parts carbonate of potash, 2 parts chloride of copper, 4 parts sulphate of zinc, 25 parts nitrate of ammonia, and use a bronze plate as the positive electrode.

TEMPERING SMALL STEEL PARTS.—I temper pinions and other small steel parts in the following simple manner: I take a thin piece of copper, say from an old dial, scrape soap upon it, bend it together, and lay the article between; I then bend the sheet firmly together, make it red hot upon a coal, and then anneal it in oil. Not even the most delicate object will warp in this manner.

COMPOSITION FILES.—These files, which are frequently used by watchmakers and other metal workers, for grinding and polishing, and the color of which resembles silver, are composed of 8 parts copper, 2 parts tin, 1 part zinc, 1 part lead. They are cast in forms and treated upon the grinding stone; the metal is very hard, and therefore worked with difficulty with the file.

LUBRICANT FOR ARKANSAS STONES.—I have found that even when good and liquid oil is used for the hard Arkansas stones, they in time get so hard as to be unsatisfactory in use. It may not be known to all that the best lubricant for all kinds of stones is a drop of petroleum, applied now and then. It makes the stone cut very much sharper, is much cleaner than oil, and does not dry so quickly.

WHITE METAL POLISHER FOR STEEL.—If the steel is of moderately good temper, use a zinc polished with diamantine; for soft steel a tin polisher is better. The diamantine should be mixed on glass, using a beater also of glass, with very little watch oil. Diamantine, mixed with ordinary oil, becomes gummy and quite unfit for use in a day or two, and if brought into contact with metal in mixing, turns black.

CEMENT FOR RUBBER AND METAL.—For cementing rubber or gutta percha to metal, Mr. Grossmann says to take pulverized shellac, dissolved in ten times its weight of pure ammonia. In this way the mixture will be of the required consistency. The ammonia penetrates the rubber, and enables the shellac to take a firm hold; but as it all evaporates in time, the rubber is immovably fastened to the metal, and neither gas nor water will remove it.

WASHABLE COATING FOR GYPSUM FIGURES.—According to C. Puscher, 3 parts caustic potash are dissolved in 36 parts hot water, 9 parts stearic acid are added, and the obtained soap paste is diluted with the same quantity water and 95 per cent. alcohol. The warm solution is applied upon the warmed gypsum cast, and this, after a few hours, is repeated with a wet sponge. The casting becomes still handsomer if, in place of potash, a corresponding quantity of ammonia is used. Old casts are first cleaned with a 3 per cent. caustic potash solution.

CLEANING WATCH CHAINS.—Gold or silver watch chains can be cleaned in a very excellent manner—no matter whether they be mat or lustrous—by laying them for a few seconds in pure aqua ammonia; they are then rinsed in alcohol, and finally shaken in clean sawdust, free from sand. Imitation and plated chains are first cleaned in benzine, they are then rinsed in benzine, and afterward shaken in dry sawdust. Ordinary chains are first to be dipped in the following pickle: Pure nitric acid is mixed with concentrated sulphuric acid, at the rate of 10 parts of the former and 2 parts of the latter; a little cooking salt is mixed to this. The chains are boiled up in this mixture; they are then rinsed several times with water, finally in alcohol, and dried in sawdust.

TARNISH ON ELECTRO-PLATE GOODS.—This tarnish can be removed by dipping the article from one to fifteen minutes—that is, until the tarnish shall have been removed—in a pickle of the following composition: Rain water, 2 gallons, and potassa cyanuret $\frac{1}{2}$ pound; dissolve together, and fill into a stone jug or jar, and close tightly. The article, after having been immersed, must be taken out and thoroughly rinsed in several waters, then dried with fine, clean sawdust. Tarnished jewelry can speedily be restored by this process; but be careful to thoroughly remove the alkali, otherwise it will corrode the goods.

AN ELASTIC LACQUER.—A lacquer, said to be of great elasticity, perfectly supple and not liable to peel off, is made in the following manner: About 120 pounds of oil varnish is heated in one vessel, and 23 pounds of quicksilver is put into 22 pounds of water in another. As soon as the lime causes an effervescence, 55 pounds of melted india-rubber are added. This mixture is stirred, and then poured into the vessel of hot varnish. The whole is then stirred, so as to be thoroughly mixed, and then strained and allowed to cool, when it has the appearance of lead. When required for use, it is thinned with the necessary quantity of varnish, and applied with the brush, hot or cold, preferably the former. This lacquer is useful for wood or iron, and for walls; it will also render waterproof cloth, paper, etc.

RESTORING BURNT STEEL.—I. The *Maschinenbauer* publishes the following recipe for restoring burnt steel: Melt 3 parts by weight of pure colophony in a crucible, and when it has become fluid, add, while slowly stirring, 2 parts by weight of well-boiled linseed oil, but be very careful in your manipulations, otherwise the mixture is apt to ignite. A dark brown mass of a syrupy consistency is finally obtained, which contains the property that any piece of cast steel, no matter how burnt, dipped in a red-hot condition into it, at once resumes its original quality, and if the operation is repeated several times, a quality of steel is produced superior to the original one. It is really surprising to see how a piece of steel, burnt until quite useless, when immersed in this mixture, may be hammered out to an invisible point, without splitting or cracking. Tempering is best done dark red, and in rain water. II. The *Metallarbeiter* gives another method, as follows: To restore steel which has been mixed by overheating, it must several times be slowly heated to red heat, and after each heating be dipped into almost boiling water. The glowing steel may also be inserted in a mixture composed of 4 parts tallow, 4 parts pitch, 3 parts sal ammoniac, and 1 part yellow prussiate of potash, in which mixture the steel is allowed to cool.

TO PROVIDE IRON WITH BRONZE-COLORED COATING.—Leopold Mayer says, in a correspondence to the *Chemiker Zeitung*: It is possible to provide iron articles with a handsome bronze-colored oxide coating, which resists pretty effectively the influence of humidity, at the same time the operator has it in his power to vary the color of the bronzing. The article, which has previously been made bright, is for from two to five minutes exposed to the vapors of a heated mixture of concentrated muriatic and nitric acids (1:1), and then, without touching it unnecessarily, heated to a temperature of 300 to 350 degrees. The heating is continued until the bronze color becomes visible upon the article; then this is cooled off, and well rubbed in with petroleum jelly, when the article is again heated until the jelly begins to melt. The article is next cooled, and again rubbed with petroleum jelly. When the vapors of a mixture of concentrated muriatic and nitric acids are permitted to operate upon the article, light red-brown color tones are obtained. But if acetic acid is mixed with the nitric acid, the vapors of which are caused to operate upon the iron, oxide castings of a handsome bronze-yellow color may be produced. By different mixtures of acids, all the possible shades, ranging from red-brown to bronze-yellow, may be obtained. The author has, for ten months, exposed rods of iron, treated in this manner, to the acid vapors of his laboratory, and they show no visible trace of deterioration.

Trade Gossip.

Peter Miller, formerly of Clarendon, Pa., is now located in Kingman, Kan.

H. A. Reineman, of Pittsburg, has bought out J. Koenig & Bro.'s jewelry establishment.

Grinberg, Goodman & Pollack offer a very attractive line of diamond goods for the holiday trade.

C. W. Lucius & Co. is the name of a new firm recently started in the jewelry business at Cincinnati, O.

H. S. Brodie & Co., of Denver, Colorado, have failed, and their affairs are now in the hands of their creditors.

The thief who stole the ten watches from a Maiden lane house must be a perfect monument of procrastination and evil impulses.

The Dueber Watch Case Company's cases have achieved a great success. The demand for them pushes their factory to its utmost capacity.

The jewelry store of G. L. Darling, at Simcoe, Ont., was recently entered by burglars and robbed of watches and jewelry said to be valued at \$12,000.

S. S. Wheeler, of the firm of Wheeler & Lord, jewelers, of Augusta, Me., was united in marriage to Miss Lizzie H. Lowell, of Hallowell, Nov. 31st.

Isaiah Vale, of Providence, R. I., has the reputation of being one of the most expert die-sinkers in the country, and some of his work is really artistic, and as near perfection as can be.

Sending watches through the mails is not the proper thing to do; moreover, they will be seized and confiscated when found, as were those two from Europe in the post office a few days ago.

Messrs. Kahn, Hanover & Co. have published a very useful work on optical, meteorological, electrical and mathematical instruments. It is copiously illustrated, and contains much information valuable to the trade.

A thief in Cincinnati recently threw a stone through a window of the jewelry store of J. Wolf, and secured a valuable lot of diamonds. He then jumped into a buggy and drove off rapidly, since which time he has not been seen.

Mr. D. Valentine, for many years a prominent jeweler in Syracuse, but now settled in New York, recently arrived from Europe with a select line of Patek, Philippe & Co. and J. J. Badollet & Co.'s celebrated watches, in all sizes.

Aikin, Lambert & Co. have issued a very neat and attractive price list of American and Swiss watches and movements; also gold and silver cases. The work is very conveniently arranged, and is the highest style of typographical art.

Vacheron & Constantin, the celebrated Swiss horologists of Geneva, have just issued a new low-price movement, called the Horse Shoe grade, possessing many of the attractive features of their other goods so universally popular in the market.

Letters patent have been granted to Robbins & Appleton for their 10-karat gold cases, fully securing the many novel features embodied in this case. In connection with this the patentees have issued a circular cautioning the trade against infringement.

A. Pickins, a well-known and enterprising jeweler at Bristol, Tenn., will occupy his new store early in December. Mr. Pickins has also two branch establishments—one in Abingdon and another in Roanoke, Va.—both doing a prosperous business.

Messrs. Robbins & Appleton will bring out early in the new year their new dust-proof hunting cases, for which they have been granted letters patent. These cases contain several novel and valuable features, which must render them exceedingly popular.

G. Seifert, of Quebec, has just received a testimonial from Her Royal Highness, Princess Louise, in recognition of the excellent work done for her by him during her residence in Canada. It consists of a photograph of the Princess, bearing her autograph, and fittingly inscribed to Mr. Seifert.

A number of jewelers in Providence and Attleboro are contemplating the organization of a Jewelers' Exchange. A committee has been appointed to communicate with the jeweler's associations of New York and Chicago, with a view to interesting them in the matter. These associations will require an intelligent and definite plan of organization before committing themselves to it.

It is stated that the commercial travelers are preparing for a united demand on the railroad companies on Jan. 1 for special tickets at rates lower than at present given them, special privilege in the way of extra-weight baggage free, reduced rate on excess of baggage, and special Saturday rates from all points.

In ornaments, diamonds have come within reach of all, and the art of extending the superficial area of gold has been carried so far that a saying is that in Rhode Island, where the manufacture of jewelry is large and fine, a manufacturer will take a five-dollar gold piece and spread over the whole State.

There is a great scarcity at the present time of good, competent workmen. It has come to be required in the trade almost generally that a watchmaker should also be an engraver, and the workman who is an adept in both branches of the art can command a permanent situation and liberal compensation.

Mr. Marcus, of Tiffany & Co., is reported to have one of the most beautiful summer residences in this country. It is located in New England, and contains some of the most elegant works of art, bric-à-brac, etc., that can be found anywhere. The house itself is a gem, both in its exterior and interior appointments.

Miller Bros. have introduced several new and unique designs in jewelry. One of these is a finely proportioned owl, with an old mine stone in its breast. How *owld* the stone is we are not informed. They have many other attractive goods in diamonds from original designs, that cannot fail to commend themselves to the trade.

The brass band, composed of workmen in the Waltham factory, accompanied the Waltham Guards in their visit to this city on Thanksgiving Day. The military portion of the New York office turned out in full. The honors of the parade were about equally divided between the Guards and the Band, although the latter made the most noise.

Louis C. Bernays has one of the handsomest jewelry stores in Arkansas. It is well stocked with everything that is new in artistic jewelry, silver, bronze, plated ware and articles of vertu and oriolu. Mr. Bernays is regarded as a very careful and critical buyer, possessing excellent taste, and is keenly alive to the requirements of the good people of his state.

M. F. Lewis, for several years in the employ of W. G. Bailey, of Helena, Montana, has been admitted into the firm, which will hereafter be known as W. G. Bailey & Co. Mr. Lewis is very highly spoken of by his late employer, and we congratulate the gentleman on the good fortune that has befallen him, which, we are assured, is as deserving as it is great.

Wilhelm & Graef, importers of ceramic specialties especially adapted for the fine jewelry trade, have in their collection some of the most superb works of art ever seen in this city. A glance at their advertisement will convey an idea of the class of goods offered by them, but falls far short of describing the artistic excellence and magnificence of their collection.

A man was recently arrested in Pittsburg while attempting to pawn a diamond stud valued at \$800. He attempted to draw a revolver, but was prevented. In his possession were found diamonds valued at \$3,000, including a scroll-shaped brooch, a cluster ring, and stones which had evidently been mounted. The goods are supposed to have been the result of a robbery in New York.

L. Luckhardt, of Johnstown, Pa., went to a barber shop to get shaved, and while absent from his store some thief made way with a tray of diamonds he had just purchased. This tray of diamonds did not break up his hand, however, as he had two good pairs left, which, we are told, in the hands of an expert possess intrinsic worth, the value of which is regulated by the size of the potlet.

Simple morals would say that the corruption of things touches the finer sensibilities. What is to become of taste and talk of art if the idea shall become prevalent that the antique things, curious relics of the wonderful handiwork of strange people, and all those things that the woman who began to learn art after her husband had made a fortune in butchering called "articles of bigotry and virtue" are cheap counterfeits?

We call attention to the advertisement of the American Watch Company announcing their readiness to supply the trade with their new watch dial, which marks the hours from one to twelve or one to twenty-four consecutively. This has been brought out to conform to the new twenty-four hour system of marking time adopted by some of the railroads. Several of the clock companies are making dials to conform to the new system.

A new clock has been erected in the tower of the Royal Courts of Justice, London. The dial was set up a fortnight ago, and the four quarter-bells are probably now in their places. These bells weigh respectively, 12, 15, 21, and 47 hundred-weight. The hour bell weighs 68 hundred-weight. From the height of the tower and the size of the bells it is expected that the striking of the hours will be distinctly heard all over London.

L. S. Stowe & Co.'s jewelry store at Springfield, Mass., was recently robbed of some \$10,000 worth of watches, diamonds and jewelry. The safe was broken open and rifled of its contents. The robbery was committed between 4 and 6 o'clock by a gang of professionals, who left behind them a fine kit of burglars' tools. An entrance was gained through a back cellar window. The burglary was not discovered until 10 o'clock, and the burglars are supposed to have left this city on the 6.05 A. M. train going east.

Captain W. R. Smith, of the steamer *Delaware*, plying between New York and New London, recently observed that whenever he came near the compass the needle flew around and pointed to him. This caused him considerable annoyance, and in seeking for the cause he discovered that his watch was magnetized. He then recalled that a short time before he had been examining an electric light dynamo machine, and it was while so doing that his watch was magnetized. He took the watch to Mathey Bros. & Mathez, who demagnetized it, and restored it to its original condition, much to the delight of the captain.

Recently a letter arrived at the post office in this city addressed to "the largest and most reliable manufacturers of silver plated ware." One of the letter carriers, with that degree of recklessness that characterizes his tribe, delivered it to Rogers & Brother, 690 Broadway, but Mr. White, Jr., with that modesty that has made him famous, hesitated to receive it, but the carrier said that he had been packing it around several hours, and as none of the other fellows wanted it, he insisted on leaving it. This quieted the alleged conscience of Mr. White, Jr., and on opening the letter found an order for a respectable quantity of goods, intended for that house.

There are rumors that after the first of January there will be a change in the policy of certain watch companies that will insure the production of a greater percentage of cheap movements. Dame Rumor also asserts that improvements in the processes of manufacture have been made by means of which the standard of quality has been advanced in these movements, while the capacity for their production has been materially increased. As these are but rumors as yet, the trade must take them for what they are worth, but it is fair to assume that they are forebodings of a coming change that is greatly to be desired. In connection with these rumors we can state that the American Watch Company's new movement will be ready to issue early in the coming year.

The retail trade has reason to be thankful to the Jewelers' Security Alliance for the success that has attended their efforts in breaking up the organized gangs of burglars that have been at work throughout the country, regarding whom we have given such frequent warning. Pinkerton's detectives, encouraged by the Alliance, recently arrested several of the most notorious of these burglars, and they are now in custody. It is known that these and their associates have robbed twenty-six jewelry stores within the past few months. Their capture, however, does not break up the gangs entirely, by any means. There are other thieves quite as enterprising to take their places, and it is known that they are still on the road and at work. The Alliance should have the hearty support and co-operation of every retail jeweler.

A young Russian electrician is reported to have invented a watch which goes by electricity, and with scarcely any movement; it is therefore simple in construction and easy to handle; it is cheap, and, above all, keeps correct time. Herr Chwolson, Professor of Physics at the University of St. Petersburg, has written an article on the subject in the *Nowosti*, in which he says: "In its remarkable simplicity this invention can only be compared with the Jablochkoff system of electric lighting. The watches are without any springs, and consist solely of two wheels. Besides being true, they have the advantage of the second hand moving in single momentary leaps, as is usually the case only in very costly watches, and which is of the utmost utility for astronomical observations. These watches can also set in motion a certain number of watches of the same construction, so that they all keep exact time. The invention has convinced me that watches can be used for the purpose of telegraphy." After naming several other advantages, Professor Chwolson describes the invention as a wonder which will cause an entire revolution in the manufacture of watches. Herr Schisgall is the son of a Jewish watchmaker in Berditschew.

M. Bréguet, the distinguished electrician and horologist, died recently. His ancestors were Huguenots, whom the revocation of the edict of Nantes compelled to seek refuge in Switzerland. There they became famous chronometer makers, but on France becoming again open to them they settled in Paris. The deceased's grandfather, who died in Paris in 1823, made important improvements in watchmaking. The deceased was born in 1814, was for three years at the Swiss chronometer factory, and on his father's retirement became the head of the Paris house. Turning his attention to electricity, he published a treatise on it in 1845, became a member of the Board of Longitude, and in 1874 entered the Academy of Sciences. His only son, who died two years ago, also took a leading part in organizing the Electric Exhibition.

"What! seventeen dollars and fifty cents for that clock!" exclaimed an old lady in a down-town store, the other day, while endeavoring to get an imported clock at half price. "Why, I thought clocks were down!" "So they are," replied the salesman, "and seventeen dollars and a half is the reduced price for that clock." "Why, I heard all the clockmakers in Europe had failed, and that clocks could be bought for almost nothing," said the old lady. "Madame, in the last two months death has laid his hand upon as many as twenty-five young 'uns in this town." "Yes, poor things." "But are nursing bottles any cheaper than three months ago?" "No," she slowly admitted. "Of course not, madame. The laws of trade are immutable. The best I can do is to throw in an extra clock-key if you take the clock at that price." And she took it.

The trade is cautioned against a person named J. J. Walker, who is traveling about the country, claiming to represent one or another well-known firms, and making drafts upon them without authority. Mr. Walker was formerly in the employ of different New York houses, but lost his positions because of his dissipated habits. He has been an excellent salesman, and now presumes upon his familiarity with the trade to obtain money from dealers. When last heard from he was in Texas, and drafts drawn by him upon firms he claimed to represent have of course been dishonored. He may have samples with him, which have been loaned him to sell on commission, but this fact does not make the owners of such goods responsible for his bills. It is greatly regretted by his old employers that Mr. Walker has forfeited their confidence, but his recent operations make this warning to the trade necessary.

Mr. Charles S. Crossman, a practical watchmaker of this city, announces that he is preparing a Complete History of Watchmaking in America, together with biographical sketches of some of the men who have been prominently identified with this industry. The author announces that it is his purpose to give an exhaustive and detailed account of the manufacture of watches in this country from its earliest infancy to the present time, and to notice all the improvements both in the watches and the machinery used in their manufacture. A work of this character, prepared with care and judgment, free from prejudice, and dealing only with facts, will be interesting to all watchmakers and dealers. There is nothing of the kind now in print, and should Mr. Crossman succeed in making a complete and accurate history of the watchmaking industry he will place the trade under obligations, and, doubtless, reap a handsome pecuniary reward.

A thief named Lobley, with several aliases, who succeeded, some time since, in victimizing several diamond houses, has at last been captured in Canada. He has had an eventful career, having first begun business as a boy in Adams Express Company's office in this city. The company having lost several packages, although they had no positive proof, suspected young Lobley, and dispensed with his services, after which the stealing from the company stopped. Lobley then went into the business of taking from the order books of the companies (which lie exposed in their offices) the names and addresses of persons who had left orders for packages to be called for. He would then call at these houses under the guise of an express employé and get any goods they had to ship. For this he was arrested, but escaped from the custody of an officer. He then went to Boston, where he engaged in the trade of getting hold of broken-down horses, doctoring them up, and then selling them as fast trotters. For this he was arrested, convicted, and sentenced to three years in State Prison, the charge being obtaining money under false pretences. Immediately after getting out he went to New York, where he swindled diamond dealers out of several thousand dollars' worth of diamonds. Other dealers in other parts of this country and England are numbered among his victims. He was finally captured by Pinkerton's detectives, and will be taken to England to answer charges pending against him.



VOLUME XIV.

NEW YORK, JANUARY, 1884.

NO. 12.

THE JEWELERS' CIRCULAR AND HOROLOGICAL REVIEW

The recognized organ of the Trade, and the official representative of the Jewelers' League.

A Monthly Journal devoted to the interests of Watchmakers, Jewelers, Silversmiths, Electro-plate Manufacturers, and those engaged in the kindred branches of art industry.

SUBSCRIPTION:

To All Parts of the United States and Canada,
\$2.00 Per Annum; Postage paid.

To Great Britain, France, Switzerland, Germany, the West Indies, Mexico, the Republics of South America, and Australia, \$3.00 per annum. Postage paid.

All communications should be addressed to D. H. HOPKINSON, 42 Nassau Street, New York. Advertising rates made known on application.

THE JEWELERS' CIRCULAR AND HOROLOGICAL REVIEW enters upon the Fifteenth year of its publication with the issue of the February number. In accordance with an established custom, all Subscriptions terminating with the present volume, ending January, 1884, will be discontinued if not renewed. We hope to have all our old friends continue with us, and to add many new names to our list of Subscribers. Of late we have received several complaints from Subscribers stating that they do not get their paper regularly; we can only say THE CIRCULAR is forwarded promptly each issue to Subscribers. We hope that our friends will notify us at once if THE CIRCULAR fails to reach them on its monthly mission; on so doing we will forward the missing copies.

End of Volume XIV.

WITH THE February issue, THE JEWELERS' CIRCULAR enters upon its fifteenth volume. Since its first establishment, this journal has enjoyed to an unequaled and most flattering extent the confidence of the jewelry trade, as has been manifested by its large subscription list and by its advertising columns. That this is so is to be attributed to the fact that it has always sought to promote the welfare of the trade, and has never pandered to unscrupulous tricksters who would prostitute the jewelers' art to the level of confidence operations. Our editorial columns have fearlessly expressed the opinions of the editor, and have not been given up to paid puffery or any men or combination of men. That our editorial space cannot be purchased is a fact so well known that of late the temptation to sell it has not been presented to us. It is because of our independent and fearless position that THE CIRCULAR has obtained a circulation and an influence that none of its contemporaries can hope to equal. In entering upon our fifteenth year of publication we make no promises for the future, save to assure our readers that the

policy that has dictated our course in the past will be continued; that the same corps of writers will contribute to its columns, and that the welfare of the trade will always be the chief object of our solicitude. While thanking our patrons for the liberal patronage bestowed upon us heretofore, we solicit a continuance of their favors, and trust to be found worthy of their confidence. Those in the trade who are not already included in our subscription list, will find it an advantage to commence their subscriptions with the beginning of the new volume, and we cordially invite them to send in their names during the present month.

A Glance at the Past Year.

THE YEAR just closed was one that the jewelry trade can look back upon with considerable satisfaction. If it was not remarkable for the volume of business it brought to manufacturers, neither will it pass into history as one noted for stagnation or depression. If there have been no periods when, in the vernacular of the day, business was "booming," neither have there been periods of utter inactivity. As so often predicted in these columns, the days for rushes of business at certain seasons of the year and remarkable dullness at others, have passed, and the transactions in the trade have become more uniform throughout the year. Those who anticipated a great influx of orders in the spring and fall have been disappointed, and have filled the air with their sorrowful cries of dull times; yet, so far as we can ascertain, the volume of business transacted during the entire year will aggregate quite as much as in previous years when the transactions were more spasmodic and fitful, orders coming in with a rush in the spring and fall, and intermitting during the summer and winter. It is better for the trade that this is so; when the volume of business flows evenly and steadily, it gives manufacturers a better opportunity to meet the requirements of the trade, to study its demands, and to supply themselves with those classes of goods that are most easily marketed. In the fitful seasons, they prepare for a rush at certain times, and pile up large quantities of goods on speculation, without really knowing whether or not the public will buy them. With the current of trade steady and even, they are not called upon to take such risks, but can meet the demands of the trade as they arise. During the past year this has been the condition of business to a more marked degree than ever before, yet dealers, while expressing surprise at the dullness, have found at the end of each month that the aggregate of their sales would compare favorably with the corresponding month of the previous year. It needed no special gift to predict that trade would take on this phase; it follows naturally upon the development of increased facilities for inter-communication. The telegraph, telephone and railroads now connect New York with every city, village and hamlet in the country; the peripatetic commercial traveler visits every dealer several times in the course of the year, exhibiting his samples, and keeping

him informed as to what is going on in the world that is of interest to him. The extraordinary facilities we now enjoy for inter-communication, bring the producer and consumer closer together, and enable the former to supply the wants of the latter at short notice, and also do away largely with the necessity for his manufacturing a large supply of goods in advance of orders. All this tends to even up the trade, spreading over a period of twelve months the orders that were formerly received in two or three, at the beginning of spring and fall.

During the past year, manufacturers of standard goods and desirable novelties did a fair and healthy business; their orders compare favorably with those of the previous year, but the margin of profit was whittled down to a pretty fine edge by excessive competition. They are, however, generally satisfied with the result. There are other manufacturers, who may be termed speculative, that are not so well pleased. These are in the habit of making up a large quantity of goods from special designs, and planting them indiscriminately among dealers, hoping to force a market for them, whether they are desirable or not. Many goods were sent out by them during the year on consignment or on memorandum, and the "returns from the back counties" are not all in yet. Many of these goods will be sent back, and some manufacturers, whose safes have been comparatively empty for a month, and who have congratulated themselves on having done a large volume of business, will find themselves stocked up again with returned goods for which there is no demand, and which can only be worked off in the future at a sacrifice. Manufacturers having these speculative tendencies, who are determined to overstock dealers whenever possible, are a positive detriment to the trade, and the conservative element is not likely to mourn greatly when this speculative ambition has a boomerang attachment and returns to plague its owner.

Retail dealers generally throughout the country are believed to be in better shape than they have been before in several years. They have gradually been going through a process of liquidation, have paid off much of their indebtedness, and are more nearly the absolute owners of their stocks than is customary. The fact that they can order goods as they need them has prevented many from running up large bills at intervals, and has had a tendency to prevent overstocking. Most of them have become better merchants, consulting the requirements of their localities more closely, and generally becoming more cautious in their dealings. They have become more prompt, too, in meeting their bills, so that collections have not been so hard to make as usual. There are still some dealers, however, who cannot say no to a traveler, or refuse goods offered on memorandum, and, as a consequence, find themselves loaded down with unsalable goods at a season when they should have fresh and desirable stocks. There are some manufacturers and jobbers who cater only to the present, regardless of the future welfare of their customers, and will use all their persuasion to overstock them with goods they know they cannot sell. This is a positive injury to the entire trade, and should be discouraged by everyone. The more nearly the supply can be made to approximate the demand, the better it is for all.

The competition growing out of the outside trade did not materially increase during the past year, but fairly held its own. That it did not increase is largely due to the disposition manifested by many dealers to "carry the war into Africa," and, by diversifying their stocks, intimidating the fancy goods dealers and the gents' furnishing goods merchants, lest the jeweler should encroach upon their specialties. Diversified stocks in many instances tended to supply a public want, and to prevent others from taking up these outside lines and, possibly, adding a stock of jewelry. But the outside dealers already established have got too firm a foothold to be dislodged, so that during the holidays the proprietors of all the well-known bazaars were found carrying their usual lines of jewelry. When our own retail dealers cater more definitely to a general trade, and keep whatever goods will catch the public eye, they will be able to hold their own with the outsiders.

The state associations of retail dealers have flattered themselves that they had pretty effectually broken up the catalogue nuisance, but in this they were mistaken. Catalogues, with price list accompaniments, have been scattered broadcast over the country by that same class of covetous jobbers who are ambitious to do not only a jobbing business, but also to steal the retail trade away from their own customers. So they have distributed their circulars freely, beseeching everybody—the butcher, the baker, the candlestick maker—to send in their orders and buy at retail at wholesale prices direct at headquarters. Western jobbers, so-called, are mainly guilty of this practice, although the little state of Rhode Island can boast not a few who are equally intent upon ruining their best customers, the retail dealers. The action of the several state associations for a time put a check to the catalogue evil, but when those organizations fell into the hands of a few self-seeking men, their influence for good became abortive. The retail dealers having thus shown their incompetency to deal with this vital evil, it might be well for the respectable manufacturers and jobbers to express their disapproval of it. It might do some good if these catalogue fiends were sent to Coventry by those engaged in the same lines of business, but who are too honorable to resort to such unbusinesslike practices to ruin the trade of their own customers.

On the whole, 1883 may be said to have dealt kindly with the jewelry trade, and there will be few members of it who will care to heap reproaches on the year that has passed away forever. Some who had been oversanguine about the volume of trade will be disappointed, but with the majority, there will be found a small balance on the right side of the ledger when the books of the year are finally balanced. There were fewer failures than usual during 1883, the trade was, as a rule, at its close, in a better condition than a year ago, and the prospects for 1884 are as full of promise for a good trade as they were at the close of 1881. Let us hope the present year may deal as kindly with us all as did the last.

The Supremacy of New York.

WE RECENTLY commented on the fact that as our frontier is extended and the great west grows more populous, many thriving, striving business centers are developed, and in them there soon spring up wholesale dealers of all kinds who cater to the retailers of adjacent cities and towns. This jobbing trade in these new business centers is becoming immense, the quantity of goods now shipped to them from this market being beyond calculation. Chicago at one time expected to control this growing jobbing trade of the west, as it has heretofore largely controlled a goodly portion of the retail trade of that section. But the evidence is accumulating that in this the ambitious city on the lake is egregiously mistaken. This is partly due to the selfishness of some of her jobbers, who have sought to rob the retailers of their patrons by offering them goods at wholesale prices, and by various unbusinesslike and questionable practices, that have tended to disgust the entire western trade with them; but is due in the greater part to the advantages which New York possesses for controlling the trade that Chicago can never hope to rival. Chicago will, no doubt, grow considerably, and always be a thriving business city, but she must be content to be fed by New York, and to act as a distributing center for a small section of country in her immediate vicinity. The great west, will, as Chicago does, come to New York for the goods requisite to supply the growing demand for the necessaries and luxuries of life. This is inevitable, for New York is the greatest manufacturing city in the United States, and in addition the great receiving and distributing point for the products of other sections as well as for all our importations from other countries. The capital of New York city conducts the chief enterprises of American industry. She has long maintained among the commercial cities of the continent, and must

inevitably continue to do so, a secure and unchallenged pre-eminence. Seated by the sea at the eastern edge of the population of the country, surrounded by her magnificent rivers and bay, making one of the largest and most secure harbors in the world—the focussing point of a net-work of railroads extending in every direction to the most distant portions of the country—she controls the trade of the country to its remotest exterior through the marvelous fertility of her resources, and attracts to her market a countless multitude of buyers from every portion of the continent by the irresistible attraction of her enterprise. Her power is felt everywhere; her manufactures, her commerce, her wealth, her arts and sciences, her social, journalistic and political influence combine to entitle her to the proud title of the Empire City.

In the complex myriad lines of trade and thought which radiate from her over all the world, she is not only the heart and life-pulse of the nation, but an important factor in the political economy of the whole civilized world. But apart from her civic greatness and the extent of her general resources; apart from her famous dry goods district, her Wall street, her docks, and her immense commercial facilities, she wins our most direct consideration from the fact of her acknowledged supremacy in the jewelry interests of the country. In this she is unrivaled and unapproachable. In New York are located the head offices of the principal factories of the East; here are located a greater number of wholesale dealers in watches, diamonds, jewelry and all that pertains to the jewelers' special industry than are contained in all the other cities of the United States. In the quality of stock carried and the volume of business done by them, their supremacy cannot be questioned even by the most envious of her would-be competitors. Rarely has any city centered within herself such facilities for the successful prosecution of any special industry as New York has for prosecuting and controlling the jewelry trade of the country. In the workshops of Maiden Lane, John street, Broadway and Bond street and other thoroughfares, are thousands of skilled artisans, contributing by their industry and art to enhancing the value of the precious metals and adding intrinsically to the beauty of rare gems. The golden product of California finds its choicest uses here; the skilled craftsmen of the art to which Benvenuto Cellini lent his brilliant genius, in the workshops of New York, to-day exert their most versatile and cunning skill; the market teems with their exquisite creations; designers vie with each other in giving tangible form to their artistic fancies, while improved machinery gives birth in a single day to more examples of their advanced ideas than would have employed for a year all the hard-working goldsmiths of the Middle Ages.

The men who introduce the products of these hundreds of workshops into the avenues of commerce, include among them the most substantial and conspicuous names known in the trade. Many of them have been established over a quarter of a century, while linked inseparably and in natural association with their names are fair dealing, liberality and enterprise. The enterprising diamond dealers, who lead the trade not only in America, but throughout the world; the manufacturers of watches, who distribute the products of their factories in all quarters of the globe, and who have made American watches famous everywhere; their compeers, who bring from abroad the Swiss rivals of these watches; the widely-known firms who lead in the manufacture of fine jewelry; the famous silverware companies whose artistic ingenuity has achieved such unexampled results; the great clock and fancy goods houses, all these are concentrated in New York and, from their combined wealth and unequalled resources, supply the dealers of the land. These, by their enterprise, honorable methods and liberal management, have won for New York that distinguished pre-eminence in their respective lines that is admitted and honored everywhere. Mention is also due in this connection to that princely retail house on Union Square, the treasures of whose establishment constitute an elaborate art collection which it is always a pleasure to visit and a liberal education to inspect. The good work done by this enterprising firm in elevat-

ing the goldsmiths' art and educating the public taste to a just appreciation of its choicest products, cannot be too highly estimated. Its influence has permeated and elevated alike the wholesale and retail trade as well as the public, and no jeweler should be content until he has paid a visit to this vast collection of the treasures of the goldsmiths' art.

But while it is gratifying to be prosperous and eminent, the ambition that has achieved these can never rest idly content upon any height attained. The lead New York so early and so easily won by reason of her many natural advantages and opportunities, will be maintained in the future by the energy, enterprise and capability of those to whose lot it falls to administer her interests. The prestige of long success is hers; her past achievements are her guarantees of future progressive development. So long as New York continues to be the producing center of this country, and the great reservoir into which flows for distribution the choicest products of the whole world, so long will she continue to be the Mecca to which all progressive Americans must make pilgrimages with greater or less frequency. We do not disparage the enterprise and commendable zeal of our neighbors of Philadelphia, Boston, Chicago, or even Rockford; we admire their ingenuity, and are frequently spurred to action by their peculiar "vim" in business competition; we wish them constant and increasing prosperity; nevertheless, neither one can be New York, and New York is the loadstone that attracts both the curious and the intelligent. No retailer in a distant city, who has been doing a moderate business, supplying himself mainly from the trunks of travelers, but, when he eventually visits New York, realizes faintly the well-defined limitations of the system upon which he has been dependent. The retail dealer from Iowa, Minnesota, or the far south and west finds it to his direct advantage to visit the great jewelry houses of New York, to enjoy their courtesies, to inspect the manifold specialties, novelties and attractive goods they keep, and which are only to be seen in the metropolis. Even the smallest dealer, whose purchases are necessarily restricted, derives unexpected benefits on such occasions by the acquisition of new ideas which he carries home and utilizes at his leisure. For a time there was an apathy in this direction. The dullness that succeeded the panic had a tendency to make dealers content with the facilities afforded them by commercial travelers, and the stagnant condition of trade offered little inducement for an extended search for novelties. But all this has been changed of late years. Ordinary staples are a drug; the demand everywhere is for fancy goods, something unique, choice, out of the old rut of commonplace. Jewelry no longer means simply "pins and ear rings." The jeweler is compelled, by sheer stress of dullness and by active competition, to seek keenly after new styles of goods that will attract his reluctant customers. If he would not fall behind his neighbors he is obliged to acquaint himself with the latest and most desirable products of the goldsmiths' art, and to profit by the enterprise of his competitors. The dealers of the country fully appreciate the many advantages they obtain by visiting the headquarters of the jewelry trade, and the influx of buyers during the past season surpassed that of all previous years. Merchants from the shipbuilding towns of Maine, and the wheat fields of the great northwest, met in the jobbing houses of New York their cousins from the cotton-growing south, while over their counters the swarthy Mexican, who is just developing into a prosperous customer, made his purchases by the side of dealers from every state in the Union. Those who are inclined to lament the decadence of old customs, and to insist that the golden era in the trade was in the bygone days when the "head of the house" was familiar with the face and voice of every customer whose name was on his ledger, must find ample consolation in the present tendency of buyers to visit New York frequently, and to make themselves familiar with what is being done at the fountain head. It is a change we are glad to see, and one that contributes to the general welfare.

To a very great extent the commercial traveler is a success. He was originally a casual experiment, but to-day he is universal,

ubiquitous and a stern necessity. Great credit must be accorded to the faithful and efficient men on the road, but the scope of their achievements is limited. No system of carrying goods to the trade, no matter how well it may be adapted to special lines, can supersede the advantages to be derived from a personal inspection of the immense and varied stocks carried by New York firms, or compensate a dealer for the loss of that personal acquaintance with the men who supply him with goods, give him credit and watch over his welfare. Other cities may make satisfactory exhibits of certain lines of goods, but in New York alone can the dealers of the country find concentrated everything required to make their stocks complete and to keep them fully abreast of the progressive spirit of the age.

THE SIGNS of the times indicate that there is an impending revolution in the manufacture of watch cases. Cheap and tawdry cases are no longer acceptable even to the cheap trade, and the time has come when slop-shop goods must go. The artistic taste of the people has been educated up to a higher standard than existed ten years ago; they have been led to expect novelties in all classes of goods, and the jewelers of the country have shown commendable alacrity and enterprise in meeting this expectation. This is a progressive age, and the case makers must keep abreast of it if they would be successful. Some of them have caught the progressive spirit, and are already catering to the demand for a better class of goods than were formerly produced, but there are others who still travel in the old ruts and wonder why their sales are falling off. Those manufacturers who have ridden into notoriety on the coat tail of a philanthropist, and imagine that their peculiar process or manufacture produces a case little inferior to 18-karat gold, will be brought to a proper estimate of their true merits by the revolution in the popular taste that is silently going on. Those manufacturers who make the best and most attractive cases are the ones who will capture the bulk of the trade. During the past few years there have been many improvements made in the processes of manufacturing cases, while the art of engraving has been greatly advanced and the cost of artistic embellishment materially reduced. Manufacturers who have taken advantage of these facts, and have improved the quality of their productions, have found their reward in such liberal orders that they are now forced to run their factories overtime to fill them, while those who still plod along in the old ruts, weep over safes full of old style cases for which there is no demand. During the past year the trade has been inundated with cheap printed matter extolling the merits of a certain class of pretentious goods; this mass of paper, however, cannot be said to have been printed up in vain, for it has served to light the fires of dealers and gave employment to some worthy printers. The public taste demands novelties and better grades of goods in all lines the jewelry trade handles, and while other manufacturers are promptly and enterprisingly meeting this demand the case makers cannot hope to stand still and make no improvements in their goods. The public has become critical and exacting, and what would satisfy them a few years ago is not acceptable now. Those manufacturers who fail to recognize the revolution in public taste had better put up their shutters at once without wasting more capital in the attempt to force a market for goods that are not wanted.

A FEW DAYS since some ugly rumors affecting the financial standing of certain well-known out-of-town houses in the trade were freely bandied about Maiden Lane and John street, and, as they passed from mouth to mouth, they were enlarged upon, until half a dozen or more firms were included in the injurious reports. Inquiry in the proper quarters soon established the fact that the stories were utterly without foundation, and that the houses referred

to were never in better condition than at present. These rumors had an extensive circulation, and cannot fail to do more or less injury to the firms thus brought under discussion, and this, too, without the slightest cause for it. There was a feeling of relief when the actual facts were made known, and none were louder in denouncing the author of the reports than some of those who had most industriously circulated them without taking the trouble to investigate them. The reputation of a business firm is too important and sensitive a thing for idle tongues to make light of; an unfounded rumor of financial embarrassment might readily bring a rush of creditors upon a house that would result in its ruin. We frequently see this done with banking institutions, when a sudden run upon it compels it to close its doors even when it is possessed of a surplus of assets. But the assets of a bank cannot be realized upon at a moment's notice, nor can those of a mercantile house, without a great sacrifice. There are comparatively few houses in business that could meet all their liabilities at short notice, and if forced into liquidation a large majority of them would be compelled to make heavy losses. Rumors affecting the financial standing of any firm should only be credited upon convincing evidence, and should never be repeated without such evidence. It is an easy matter to start false reports, but no one can predict to what results they may lead. We trust the experience gained by many through the reports circulated recently will tend to check idle gossip in future on so important a matter as the reputation of reputable and honorable firms.

Lacquer Ware.

A DESCRIPTION OF THE PROCESS BY A JAPANESE.

THE LACQUER ware, or Japan ware, as it is sometimes called in America and Europe, claims and takes the first place among our art industries. The finest and most valuable examples of Japanese art works are mostly to be found in lacquer ware. Nothing can surpass or even equal the finest piece of lacquer ware in its beauty, delicacy, finish or perfection of detail. Sir R. Alcock, speaking of a lacquer cabinet, says in his "Art and Art Industries of Japan" that "the best and most skilled hands employed in producing the objets de Paris—charming evidences as these afford of artistic taste and skill of hand, or the most deft of the art manufacturers of Vienna or Florence—could not match it by any effort, single or combined, if the same materials were supplied to their hand." Dr. Dresser in his lecture at the Society of Art remarks that "perhaps the most beautiful art of Japan is the lacquer manufacture," and further says that "some are unequaled by any works, so far as I know, that any other people have produced."

In Japan the finest pieces of lacquer ware are valued and admired more than any other works of art. All the best and old specimens of lacquer ware are eagerly bought, should any be found in market at home, regardless of their extraordinary price, and it is the fact that the best specimen of lacquer ware to-day brings more than its weight in gold. It is impossible to convey by engravings, as Sir R. Alcock says, any idea of the beauty of effect of lacquer ware, because that depends in no small degree on the polish of the surface, the brilliancy and harmony of superimposed colors and variety of textures, forming either pictures or basso relieves, together with the refined delicacy of touch displayed in the work.

The art of lacquering is distinctly Japanese in its origin, and it is already more than twelve hundred years old. The pieces made in those olden times are still extant in the country. The oldest specimen of lacquer is the scabbard of an imperial sword worn by Emperor Shioum, and supposed to have been made about twelve hundred years ago and dedicated to the temple of Todaiji of Nara, the old capital of Japan, by Emperor Koken, in the year 749, A. D. There are beside this several specimens of the oldest lacquer pieces in the temples of Todaiji and Saidiji of Nara.

The art of lacquering, we may say, was in its infancy until the periods of 1174, A. D., and 1185, when many celebrated makers, such as Norisuye, Sadayasu, Sukemasa, Sadamitz, Suyetsune, and their pupils, made some great improvements in manufacturing lacquer ware, and introduced into it many new devices. During the interval from 1185 to 1600, there were some slight changes in lacquer ware, but no great advancement was noticeable until the period of one hundred years between 1600, A. D., and 1700, when the master pieces of lacquer ware were made by Haritsu or Ritsuo, Hon-Ami Kowyetsu, Komono Kihaku, Kagigawa (The First), Yamamoto Shiunsei, Korin (Ogata Korin), Seikai Jiuhichl and Mochidsuki Hanzan. Later after 1800, A. D., the names of Komano Kausai, Enouye Hakusai, Hara Yeoyusai, Shibata Zashin, Iketa Taishiu, Nakayama Komin and Oagawa Shiomin are well known.

A short description of the manner in which lacquering is done may be of interest to the readers of THE CIRCULAR and here we will describe it as briefly as possible. The operation depends, of course, on the peculiar properties of the lacquer, and the effect to be produced. The raw lacquer, chiefly the *Seshime urushi*, is used for priming, with an addition of burnt clay dust, or fine stone powder, so as to produce a coating of the utmost hardness. The prepared lacquer, after having been strained, is slightly transparent when applied in thin layers, and possesses a color similar to that of shellac; this transparency is occasionally increased by a small addition of drying oil, which, by mere hardening, produces a sufficient glossiness of the surface, whereas the pure lacquer has to be polished. For coloring the lacquer is mixed with cinnabar or pigment, red oxide of iron or Prussian blue, etc.

The black lacquer is prepared in the following manner: It is effected without any addition of solid particles, such as lampblack or similar substances, but merely by stirring the crude lacquer for a day or two in the open air, whereupon it assumes a very dark brown color. Toward the end of the operation a small quantity of water, which has been kept standing for a few days, mingled with iron filings or a gall nut infusion darkened by the addition of iron, is added, and the whole stirred again until part of the water has evaporated; then the lacquer acquires proper consistence and color. The addition of this water is said to cause the highest brilliancy and blackness of lacquer. Sometimes the colored lacquer is used when the final coating is required to be of a transparent nature. Either the unmixed, strained lacquer, or that peculiar kind of lacquer which has been thinned by an addition of oil, is used.

The mixing of lacquer with hardening or coloring powders is generally effected by the lacquerer himself on a wooden board with a wooden spatula just before using it. Finally, the thick mixture is forcibly strained through a piece of paper called *yoshinogami*. Should the lacquer become too stiff for use, some bits of camphor are crushed and thoroughly mixed with the lacquer by spatula, and then it becomes more liquid. Before beginning to lacquer, the artist often lines the exterior of the objects, and especially the joints and corners, with linen gauze or *yoshinogami* pasted on with raw lacquer so as to give the objects greater solidity and to prevent its breaking.

The primary coatings are put on with a mixture of raw lacquer and burnt clay powder and afterward stone powder. When hardened they are rubbed with a grindstone to smooth and polish the surface. The next two or three layers are done with inferior kinds of the black or colored lacquer, according to the color to be produced. The lacquer is applied in the first place with a wooden spatula and afterward with a very stiff, flat brush, so as to smoothen and spread the lacquer equally. The surface is then ground with water and charcoal, of which latter two kinds are used, the one coarse and hard and the other light and soft. As a peculiarity it may be stated that the freshly lacquered objects are placed in large wooden boxes, the inside of which has been sprinkled or washed with water, so that the process of hardening takes place in a dark and damp atmosphere. According to the statement of the professionals, this

precaution is absolutely necessary to produce the speedy hardening and fine appearance of the lacquer.

The final coating is done with the best lacquer of the kind required in the particular case, and after having been carefully ground it is polished with deer horn powder. The black lacquer, when finished, is repeatedly rubbed with a ball slightly in the *Seshime* lacquer, and each time carefully polished with powder made of deer horn. The gold sprinkled lacquer, called *Nashiji* (literally pear surface), is produced by sifting a certain amount of gold leaf cut into small pieces on to a fresh coating of *Seshime* lacquer. When hardened, the surface is smoothed and then coated with a choice quality of lacquer, called the *Nashiji urushi*, which is prepared by carefully straining and mixing it with a small quantity of gamboge. The lacquer, when applied in thick layers, is opaque, and only becomes transparent in thin layers; so that, by grinding the final coating with charcoal, the gold sprinkles underneath can be made more or less visible, according to the will of the artist.

Finally, after being carefully polished, the object receives a very thin coating of the same lacquer to produce the glossiness. For common ware, tinfoil is used instead of gold leaf, but owing to the yellow color of the *Nashiji urushi*, the tinfoil has a gold-like appearance. The method of lacquering always remains the same, but the number of coatings can be reduced. The priming may be done with cheaper materials, or the lacquer may be of inferior quality. The final process of decorating the objects is one which admits an almost infinite variety of devices, and consists either of paintings or of incrustations of mother of pearl, metals, etc., or else of a peculiar preparation on the surface.

The relief paintings are done with a mixture of red oxide of iron and lacquer, upon which fine charcoal powder is brought to bear before the lacquer has hardened. This again is coated with lacquer and colcothar, the operation being repeated until the required relief works have been produced.

The metallic powders, viz., gold, silver, bronze, etc., are applied to the final coating while the lacquer is still in viscous condition, so that the powders being, so to say, soaked into the fresh lacquer, a thick layer, chiefly composed of metal, is produced. After the lacquer has become hard the painter removes the surplus of the powders, and either polishes the painting or simply rubs it over, according to the result desired. It is unnecessary to add that lacquer painting is an art which admits almost of as many different methods of producing a certain effect as that of oil painting. Indeed, although the painter in lacquer has only a very limited number of bright colors at his disposition, he can make use of a larger number of dark brown and neutral tints, and also of various metallic powders, besides which he has it in his power to modify the surface as he pleases, viz., making it dull or brilliant, smooth or grained, producing relief or flat pictures. The lacquer can be carved, and finally the artisan can incrustate mother of pearl, ivory, thin metal or anything he likes into the lacquer.

By mixing a sort of paste made of bean powder or the white of eggs with the lacquer, he can then thicken it to such an extent as to give it a kind of plasticity, admitting the possibility of making impressions which remain visible after hardening. This is done, for instance, with the so-called *Tsugaru* lacquer, which presents a marbled appearance, with red, brown and green veins. The first coating is done in black lacquer, which is mingled with white of eggs, and by tamping with a ball of cotton, or some similar operation, the surface is made to present a mass of irregular depressions, which remain after hardening.

The latter are partially ground down, and a second coating of a different color is applied and similarly treated. After having finished the coating with variously colored lacquers, the surface is ground until all the successive layers appear again in veins of different colors. It would take too long, and would even be impossible, to describe all the devices made use of by Japanese artists for their finest specimens of lacquer.

To appreciate the really beautiful creations of this art to their full value, it is necessary to examine the pieces, down even to the smallest details, to compare the common pieces with those of the best workmanship, and in this manner to educate the eye to a certain extent. There is little doubt that anybody who has had such opportunities will become more and more fond of these products, which combine the most varied devices of technical as well as artistical ingenuity so admirably. It need scarcely be added that the ordinary lacquer does not present all the features of the fine specimens. For this purpose the different methods of lacquering and painting have been considerably modified in order to produce cheaper articles; nevertheless, the nature of the material gives a beautiful appearance even to such inferior ware.

The finest lacquer is made in Kioto, Tokio and Osaka; the cheaper articles are mostly manufactured in the interior, as, for instance, in the provinces of Aidsu, Yechizen, Wakasa, etc. A peculiar kind of lacquer is the so-called Wakasa ware, having a marbled surface of chiefly green and red lacquer, or showing brown colors, with a sort of metallic luster produced by the foils beneath the final coating. The art of carving lacquer was introduced into Japan by a Chinese artist; several hundred years after, some Chinese came to Japan to learn the art of lacquering. The carvings mostly represent flowers, birds and figures, and they are done either in red lacquer or black lacquer. We may also place the Guribori under the carved lacquers. It is made in the following manner, viz.: Thick layers of various colored lacquers are successively applied, one upon the other, the last one being always of a dark brown color; broad, meandering lines are thereupon engraved with inclined faces, upon which the different layers reappear in parallel lines.

The *Shunker urushi* should also be mentioned here, which being transparent and of a yellowish tint, is used to produce upon wood an effect similar to that of French polish. When Shunkei ware is made the surface is first prepared with a primary coating of glue and alum so as to fill up all the pores, and is then polished and sometimes painted with gamboge or safflower, together with the sap of unripe persimmons, which gives it a brighter appearance. Afterward the coating of varnish is applied with a stiff brush, and as a certain percentage of oil has been mixed with the lacquer it requires no polishing, but acquires the brilliancy by mere hardening. The most celebrated lacquer of this kind is made in Akita, and it is said the process is effected at sea on board ships so as to avoid all dust and to allow the lacquer to harden in moist atmosphere, which produces gloss of remarkable beauty.

In conclusion, it should be remarked that the best lacquer wares manufactured to-day are as fine as those of former years in every respect, though it would be too much to assert that they equal the masterpieces made by the celebrated artists of olden times.

American Gems and Precious Stones.

A Paper presented to the United States Geological Survey by George F. Kunz.

Continued from Page 358.

Phenakite.—Phenakite has recently been found at Pike's Peak, Colorado,* in crystals of sufficient size and quality to furnish fair gems. Some fair sized crystals of remarkable clearness were found here recently. They are equal in point of quality to any found elsewhere, and further finds may produce crystals equal in size to those from Siberia. Though rare, this gem is colorless, and hence its value is almost purely mineralogical.

Zircon.—Zircon has not yet been found in this country in pieces sufficiently large or good to warrant cutting. Some very small crystals of good color have been found in Burke county, North Carolina, and the ends of some of the Saint Lawrence county, New York,

zircon might cut into very small imperfect gems; but nothing further of more than mineralogical value has been found.

Garnets.—The garnets found in New Mexico and Southern Colorado, and there called "rubies," are as fine as those from any other known locality, the blood-red being the most desirable. Very fine almandine, hyacinth yellow, and other colors are also found associated with olivine and sapphire. Chester county, Pennsylvania, has afforded some fair gems, and some quite fine ones have been found at Stony Point, North Carolina, and at other localities, but the only ones used as gems are from New Mexico, Arizona, and Colorado, which yield annually about \$5,000 worth of cut stones. As an example of their quality, a remarkably fine one was sold to a gem connoisseur for \$50, but equally good stones have often sold for much less.

Essonite (cinnamon garnet).—Essonite has been found in very fine crystals at Phippsburg and Warren, New Hampshire; Raymond, Maine; and at many other points in America. Yet only occasionally crystals are found that will cut gems even of value to collectors.

Grossularite has recently been found in perfect, opaque crystals in Gila cañon, Arizona.

Tourmaline.—The principal source of tourmaline in the United States is the famous locality, Mount Mica, Paris, Maine, which place has from time to time produced some of the handsomest achroites, rubellites, indicolites, and green tourmalines known. The tints of the green, blue, pink, and yellow tourmalines found here are usually of the light and most desirable shades.† Work is now being carried on. The yield for 1882 was something over \$2,000, and the entire quantity of gems that have from time to time been taken from this locality, at the higher rate asked for them as American gems, would possibly amount to from \$50,000 to \$65,000.

Colored tourmalines have been found at Hebron, Norway, and Auburn, Maine. Extended work may bring as fine gems to light here as at Paris, Maine, as the indications are equally good at all these places.

Colorless and brown tourmalines, which cut into fair gems,‡ have been found at De Kalb, New York. The fine black from Pierpont and the fine brown from Gouverneur, in the same State, have no value as gems.

Iolite.—Iolite has been found at Haddam, Connecticut, in pieces of a dark-blue color and sufficiently clear to cut small gems, but these were of local and mineralogical value only, owing to their small size.

Spodumene.—Spodumene has been found transparent at two localities in the United States, the variety hiddenite or "lithia emerald" at Stony Point, Alexander county, North Carolina, and a variety of amethystine color at Branchville, Connecticut.

Hiddenite§ or "lithia emerald," is found associated with emerald, beryl, rutile, and garnet; the more valuable is the rich grass-green, and is rarely met with. Quite perfect gems of good color, weighing 2½ karats, have been cut. The light-green, yellow, yellow-green and colorless have a lower value. The green is a new and strictly American gem, and the demand exceeds the supply. This and the tourmaline are the only gems that are being actively mined at present. The total sale of gems found and sold from the beginning of operations in August, 1880, to the close of 1882, amounted to about \$7,500, the yield in 1882, during which only preparatory work was being done, being about \$2,000 worth of gems.

The Branchville spodumene|| would afford only very small gems of a light amethystine color. The alterations in color which have taken place have entirely changed it to what might almost be called a defunct gem, which would otherwise have afforded material for gems over one inch in thickness and several inches in length. The

† Collections of Dr. A. C. Hamlin, Dr. Joseph Leidy, and Prof. C. U. Shepard.

‡ Collection of Dr. Joseph Leidy.

§ Cf. paper by Mr. W. E. Hidden, p 502 of this report.

|| *American Journal of Science*, i., 318, 1879.

* *American Journal of Science*, October, 1882.

color before the alteration was probably much richer. The Branchville variety has only a mineralogical value.

Danburite.—Danburite* has been found in considerable abundance at Russell, New York. Only an occasional crystal is clear enough to cut even a small gem. The color is usually wine-yellow, honey-yellow, or yellowish brown. It has not yet been used as a gem.

Rock crystal (quartz).—Rock crystal is found at a great many localities in America. In Herkimer county, at Lake George, and throughout the adjacent regions in New York State, the calciferous sandstone contains single crystals, and at times cavities are found filled with doubly terminated crystals often of remarkable perfection and brilliancy; these are collected in numbers, cut, and often uncut are mounted in jewelry and sold to tourists under the name of "Lake George diamonds." Those sold in large cities under the same name are, however, often simply paste or glass, which possess more brilliancy but have not the same durability. Of the Herkimer crystals possibly \$3,000 worth are sold per annum. In Arkansas, at Crystal Mountain and in the region for about forty miles around Hot Springs, large veins of quartz are frequently met with. The quartz is taken to Hot Springs and Little Rock by the wagon load by the farmers, who often do blasting to secure the crystals, looking for them at such times as their crops need no attention. In the course of a year possibly 100 loads are sold, principally as mementos, to the visitors at these resorts. Crystals are also sent to other localities for sale. Usually only one-half of the crystal is clear, and a clear space over two inches square is quite uncommon. The sale of the uncut ones from this region amounts to fully \$10,000 per annum.

At Hot Springs clear, rolled pebbles are often sold, that have been found on the banks of the Ouachita; these are more highly prized than the crystal, as the common fallacy prevails that they cut clearer gems. The scarcity of these and the demand for them has so worked upon the cupidity of some that they have learned to produce rolled pebbles by putting numbers of the crystals in a box which is kept revolving for a few days by a water power. Any expert, however, can discern the difference, since the artificial ones are a little whiter on the surface.

Many localities in Colorado furnish fine specimens, and all along the New Jersey coast, at Long Branch, Atlantic City, Cape May, and other places, transparent pebbles are found in the sand, and are sought after and found by the visitors, who often have them cut as souvenirs.

Large masses of clear rock crystal have been found in North Carolina, and would be of use in the arts.

At all of these places large quantities of the quartz cut in gems, seals, and all manner of ornaments are sold as having been found in the vicinity. Sometimes even the stones that have been found by the visitors and brought by them to be cut are exchanged for those already cut and brought here from Bohemia, Oldenburg, and the Jura, where cutting is done on a large scale and by cheap labor; the cut stones costing delivered in America not more than one-tenth of the price of cutting done here, as the rock crystal in the articles really costs very little.

The annual sale of cut stones and money expended in cutting, at the different localities, may amount to \$20,000 or more per annum, and the sale of specimens to as much more.

The clear crystal for optical purposes used in this country is almost entirely Brazilian, not that the American is not fine enough, but the good material found here rarely reaches the proper channels, and the Brazilian is cheap and is used from custom.

Smoky quartz or cairngorm.—Smoky quartz, smoky topaz, or cairngorm, is found in large quantities at and near Pike's Peak, Colorado. It is also found to some extent at Anteros Summit, Colorado; Magnet Cove, Arkansas; Burke and Alexander counties, North Carolina, and at other points. The Pike's Peak material is sent abroad in large quantities for cutting, and the larger part is returned

to be sold in tourists' jewelry, principally at Denver and Colorado Springs, Colorado; Hot Springs, Arkansas, and other western cities and resorts. The sum realized from the cut material amounts to fully \$7,500 annually, and the crystals sold to fully \$2,500 more.

Rose quartz.—Rose quartz occurs in large masses at Albany and Paris, Maine; Southbury, Connecticut, and at many other places in America, but as yet it has not been used at all in the arts or as a gem.

Gold quartz.—Rich pieces of gold quartz are worked into jewelry and souvenirs on a considerable scale in San Francisco, and to a less extent in many of the larger towns in the mining regions. Some of the gold mines in California, Oregon, Idaho, and Montana have furnished very fine specimens, which are especially handsome when the quartz is clear and the gold penetrates it in compact stringers. Gold miners, however, often have a prejudice against what are known as "specimen mines;" that is, mines furnishing ore of this class. A few years ago it was estimated that \$50,000 worth of this gold quartz was thus manufactured annually, but both the demand and the supply have latterly declined.—A. W., Jr.]

Amethyst.—Amethyst has been found on Deer Hill, at Stowe, in a vein fully one-quarter of a mile long, and at other places in Oxford county, Maine; Chester county, Pennsylvania; in Colorado and Virginia and other regions, although not affording as large fine gems as the Brazilian or the Siberian. It is not used except for mineralogical gem collections. There are a great many amethyst crystal groups sold to tourists and collectors, and the sales from this source may amount to from \$1,500 to \$2,000 per annum.

Sagenite.—Sagenite, "rutile in quartz," "*flèche d'amour*," or "Venus' hair stone," is found at many localities in the United States. The principal supply comes from Iredell, Alexander, and other counties in North Carolina. The rich red, golden yellow, brown, and intervening shades are often cut into oval seals and charms for use as jewelry. The stone gives a very pleasing effect by sun or gaslight. The quantity used annually will amount to over \$250 as gems, and as much more for mineral specimens.

Thetis hair stone.—Thetis hair stone, near Sneach Pond at Cumberland, Rhode Island, is occasionally met with in fair pieces, and is used to a limited extent in jewelry, probably less than \$100 per annum.

Hornblende in quartz is found at Diamond Hill, Rhode Island, and is used to some extent in jewelry, principally in the cheaper grades. The amount used annually is probably worth about \$500.

Agate and chalcedony.—Agate and chalcedony are found in a great many localities in America. Among them may be named Agate bay, Lake Superior, where large numbers of small banded agates, usually of a red color, are found. These are quite extensively cut and are sold to tourists who visit Lake Superior. Some fine large agates are found in different parts of Colorado and through the Rocky mountains, many of them very beautiful; though only a small proportion are cut or polished, owing to the cheapness of the agates from Brazil and Uruguay, which are cut and sold at so much lower rates in Germany. Nearly all the polished agate specimens sold in America are from the German market. Possibly \$2,000 worth of American agates are sold annually.

Moss agate.—Of all the American stones used in jewelry there is no other which is sold so cheaply, and of which so much is sold, as the moss agate. Those found in the brooks and streams called "river agates" are the most desirable. Nearly all are sent abroad for cutting and then most of them are returned for home use. When this stone was fashionable fine ones were worth from \$10 upwards, and as many as \$20,000 worth were sold a year, but at present they are used only in cheap and tourists' jewelry. The principal sources of supply are Utah, Colorado, Montana, and Wyoming Territory. At present the moss agates collected amount to about \$12,000 to \$15,000 worth per annum, and the demand is declining.

Silicified wood.—Wood agate, wood opal, and silicified woods of all kinds are found in great abundance in Colorado, California, and

* *American Journal of Science*, III., XX., III., 1880.

others of the western States and Territories. For colors, variety, and the polish they admit, they are unequalled elsewhere; a great many articles of cheap jewelry and a variety of fancy articles are made from this material and are sold principally to tourists. Some pieces having a marked and desirable peculiarity or beauty are often sold at fancy prices. The quantity annually cut and sold amounts to nearly \$10,000, and besides a large quantity is sold as cabinet specimens.

Jasper.—Jasper is found at many localities and in a great variety of colors in the United States. A fine green jasper is reported to have been found at Norman's Kill,† New York, fine red, yellow, and brown at Murphy's, Calaveras county, California, in great variety, and also in parts of Colorado. Near Colyer, Graham county, Kansas, is a bed of banded jasper; the colors are mainly red and yellow, with bands of white, and these bands are so remarkably even that the stone would furnish an excellent material for cameo work. Should this style of jewelry come into vogue again this may prove of considerable value; as it is, the beautiful red and yellow are so strikingly relieved by the white that it makes a fine ornamental stone. Jasper is very little used in the arts, for so common a stone, and the entire annual sales would not be more than \$1,000.

Novaculite.—Novaculite is found at Hot Springs, Arkansas, and has been used to a very limited extent for cutting figures, such as owls and birds, for jewelry. It is pure white, and makes a very pretty ornamental stone. The amount sold is now less than \$100 worth per annum.

Epidote.—Epidote, although found in many localities in the United States, and in very large crystals, ranging from brown to green in color, is only translucent or semi-opaque when in very minute crystals, and no American gems of this mineral have come to our notice.

Idocrase.—Idocrase, although found in fine crystals of a dark-brown color at Warren, New Hampshire, Sanford and Raymond, Maine, and other localities, rarely occurs with sufficient transparency to cut even small desirable gems.

Chrysolite, olivine, peridot.—Peridot is found of very good quality in small, olive-green, pitted grains or pebbles, associated with garnet and sapphire, in the sands of Arizona, New Mexico, Colorado, and Montana. This material affords smaller gems than those from the Levant, and as the demand seems to be for the large peridots and also the richer olive-green color peculiar to these, and not the American, for these reasons only a smaller number of the American are cut into gems, and \$500 will fully cover the amount sold annually.

Rutile.—Rutile has been found of sufficient compactness and luster in Alexander county, North Carolina, and at Graves mountain, Georgia, to be used as a gem.‡ The rutile from the former locality, when cut, more closely resembles the black diamond in color and luster than any other known gem. If enough could be found fit for cutting, it would become popular as a rich mourning gem. The rutile from Graves mountain, when cut, more nearly approaches the garnet in color, and is therefore not as desirable.

Hematite.—Hematite, although found at many localities in the United States, is rarely compact enough for cutting, and is not used for that purpose, owing to the cheapness of the foreign mineral and cheap-cut gems sent to this country. Some exceptionally small richly-colored pieces have been found near Gainesville, Georgia. The cut specimens sold at the Lake Superior resorts are almost entirely of foreign stone and cutting.

(To be Continued.)

Lathes and Lathe Work.

BY THE MODEL WATCHMAKER.

IN SUCH a lathe as described in last article, *i. e.*, one made from a bow lathe, you can use all of the taper and screw arbors which are so convenient with the bow lathe, as one of the slides for carry-

ing the lathe centers can be used as a tail stock. At fig. 1 is shown such a lathe, with a screw arbor, such as you would use with a bow lathe to true up the barrel for a fusee watch. Of course taper arbors for turning up center pinions for Swiss watches can be used in a similar manner. A chuck must be fitted up to go into the live spindle, as shown at *a*, fig. 1. An enlarged view of such a chuck is shown at diagram *A**, where *E* represents the chuck, as seen in fig. 1, while *F* shows a face view as seen in the direction of the arrow at *c*. The face plate *a* has a slot, shown at *d*, to receive a pin from the pulley on the taper arbor. At diagram *H** is shown (enlarged) a common taper arbor; here *s* represents the pulley for the gut cord when used with the bow, *j* the taper arbor, *g* a pin driven into a hole drilled into the pulley *f*. At diagram *K** is

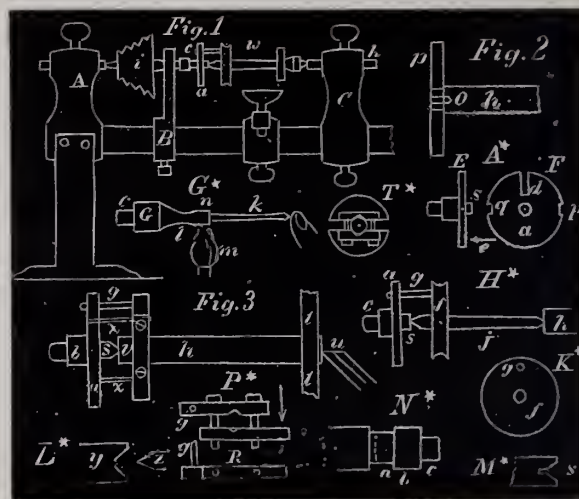

shown a face view of the pulley *f*, seen in the direction of the axis, showing the position of the pin *g*. The slot in the plate face shown at *d* being cut deep, will take the pin (*g*) from all sizes of pulleys. It is but a small job to drill the pulleys on all your arbors, as such a lathe is as near perfection for drilling as any reasonable man can ask. It will, if the pulley *i*, fig. 1, is made $1\frac{1}{4}$ inches in diameter, carry a drill $\frac{1}{16}$ of an inch in diameter rapidly through any substance it will cut. A good chuck for holding drills is shown at diagram *G**; the part *G* is made of brass, the piece *c* screws into the spindle of the lathe, at *l* the chuck is turned down as small as is consistent with strength, while the part at *n* is drilled to receive the back end of the drill. The drills are secured in *n* with soft solder by heating the part at *n* with the alcohol lamp flame shown at *m*. The drills should be *tinned* with soft solder. To set the drill while the lathe is in motion apply the finger as shown, letting the lathe revolve. The process of setting is very much like truing anything up in a wax chuck, except the solder is not so plastic, as when it sets it sets all at once. A little practice will soon enable one to center a drill perfectly true, and when they are set there is no coming loose. For drilling straight or upright a device shown at fig. 2 is good; it is a piece of wire just like one of the centers which goes into *C*, fig. 1, with a face plate shown at *p*; *n* is drilled into a little at *o* to receive the point of the drill. This face plate will hold any job so that it will be presented at right angles to the drill. To make such a face plate the disc *p* should be soft soldered on *n*, and turned off flat and true. The back rest described in last number of this journal should be used to center the piece of wire used for attaching the face plate *p* to. The method of doing this is to take a piece of brass wire long enough to make such a tail piece, and drill a shallow hole in one end; this shallow hole is to let the cone center of the live spindle of your lathe go into; you next fasten on a dog to the piece of wire, and let the dog pin go into the notch *d*. Now put the back rest on the lathe so the end just protrudes, and with your graver turn in a center pit and drill the hole *o*, fig. 2. If you desire to be very accurate, you may change ends with the piece you are turning, and turn in a new center at the end now resting against the cone center of the live spindle. To make this matter perfectly plain we will go over it again, commencing with making the

† A fine specimen of heliotrope or bloodstone is reported to have been found here, but the same finder reported a similar and entirely unreliable occurrence in Texas, and the stones from both are evidently of foreign origin.

‡ *American Journal of Science*, III., xxi., 1881, i., 227.

plate face and chuck shown at diagram *A**. Take a piece of brass wire fully $\frac{1}{4}$ of an inch in diameter and an inch and one-half long, center this at each end, drilling slightly at each counter-sink; put on this piece of wire one of your large split screw collets, as shown at diagram *T**; put this into your bow lathe and turn up the wire until shaped as shown at diagram *N**, where *c* represents the part on which the screw is to be cut which is to screw into the spindle of your new lathe. When of the right size, cut a screw on *c* to fit into your live spindle at *c*, fig. 1. The shoulder shown at *a*, diagram *N**, is to receive the face plate *a*, diagram *A**; the chuck should now be sawn off at the dotted line in diagram *N**, when it can be screwed into the live spindle shown in last number of this journal, and also at *c*, fig. 1, present number. After centering and drilling for the steel centers, the part on which the face plate goes should be slightly turned up, and the face plate *a* riveted and soft soldered on; turn up the face, and cut the slot *d*. The steel center *s* can be screwed in, using a smaller top than for the screw at *c*. It is better to make two of these face plates, one having a positive cone center, and the other with a hollow cone, than to try and use one face plate for both centers. You will find there will be less likelihood of being out of true. These steel centers should be hardened and then run down to a good spring temper so they can be trued up by turning with the graver. The hollow cone should be drilled as shown at *s*, diagram *M**. In fact, you should make it a rule never to use a hollow cone except it has a hole drilled at the bottom, as shown at *s*, diagram *M**. We have got back now to centering by means of the back rest. This is something so important that I shall describe the details minutely. I gave a description of a universal dog in a former article, but as there may be some of my readers who have not these numbers, I will describe it again. It is made of two pins of hard brass or steel, about $\frac{1}{8}$ of an inch square and $\frac{1}{2}$ an inch long, coupled together with two screws, as shown at diagram *P**, *R* being a view seen in the direction of the arrow, and *g* the pin to go into the slot *d*, diagram *A**. Suppose now we have a piece of wire we wish to center very accurately, we will say it is for *u*, in fig. 2. We cut it off square at each end, and guess at the center as near as we can; we drill in at one end, say $\frac{3}{8}$ of an inch. We put on the universal dog (shown at *P**) as shown at *R*, fig. 3, and apply the back rest (described in last number) shown at *t*, and with the graver *u* we turn in a center absolutely true. If now we reverse ends (after drilling a small hole in center turned by the graver at *u*) and turn out the center at *v*, drilling a new hole, we shall have our piece of wire centered perfectly accurate. If we now remove our back rest and put the piece of wire we have just centered into the lathe in place of the screw arbor shown at *w*, fig. 1, we can turn up the shoulder against which the plate *p*, fig. 2, goes; then take it out of the lathe and solder *p* on to *u*, when we can restore it to the lathe face off *p*, and feel sure that our work is so far true. I have dwelt somewhat at length on the manner of using a back rest for getting accurate centers, but it is very important for some jobs—suppose, for instance, a new punch for a Hall staking tool; this method would make one absolutely correct. Some difficulty may be experienced in keeping the piece of wire *u*, fig. 3, in the lathe, or, rather, to keep the cone center *s*, fig. 3, in place, and the job coming away from it. It will be seen at *q*, diagram *A**, that the face plate *a* has two shallow notches; these notches are to keep in place a light rubber band, one of the smallest used being quite sufficient. The position of this band is indicated at *x*, fig. 3; it is passed over both, so as to exert a constant pressure on each, tending to keep *v* pressed on *s*. The method of making the ordinary cone wax chuck is too well known to need remarks except to say you must be sure no little point remains sticking up, as shown at diagram *L**. This leaving a positive cone at the bottom of a wax chuck is something done oftener than many who work with, and use daily, such a chuck would believe; but if they will take the trouble to examine with a double eye-glass, they will be convinced that what they supposed was a perfect hollow cone is really shaped as shown at *y*, diagram *L**. This defect can be

remedied by using a hardened steel point, turned to a perfect point, and polished as shown at *z*. The angle of this point should be a trifle more acute than the hollow cone, and it is used by pressing it into the hollow cone as the lathe revolves; one end resting against a back center and the other pressed into the hollow cone. The piece *z* should be held and the lathe revolved. Of course it is to be understood that the hollow cone is tuned as near perfect as possible before *z* is used.

Sight.

WHAT THE OPTICIAN SHOULD KNOW ABOUT OPTICS.

Based upon an extensive hospital experience in Austria, Germany, England and New York. By C. A. BUCKLIN, M. D., New York. Author of Detection and Correction of Visual Imperfections, Cause and Cure of Cross Eyes, Effects of Color on Distance, and Monograph on Astigmatism.

Continued from Page 325.

I regret that our enquiries are not more numerous, but the letters received show that the opticians of this country have done more thinking during the past year than they have before for a series of years. The following letters most decidedly show that they are written by intelligent and thinking persons.

PULASKI, N. Y., Nov. 30, 1883.

DR. C. A. BUCKLIN:

Dear Sir:—I use to read lenses No. 60 concave cylindrical axis horizontal. To use for watch work I have two magnifying glasses, one $\frac{7}{8}$ inch diameter double convex 3 inch focus, the other $\frac{7}{8}$ inch diameter, and about $\frac{7}{8}$ inch focus double convex. Do not use spectacles for watch work, they are in the way, although my eyes do not become tired so quick with them on. Please advise me if I cannot have made two magnifying glasses to use in place of above which will combine the advantages of my spectacles. O. V. D.

I cannot be sure that his No. 60 concave cylindrical lens axis horizontal is the best he could obtain for reading. He can, however, combine the lenses so as to obtain the combined advantage of both magnifying glass and spectacles. You can have a magnifying glass of three such focal distance combined with a concave sixty cylindrical so that the two form one lens. The eye piece in which this lens is mounted should be marked so that you would know the instant you take it up just where the axis of the cylindrical lens stood. This has been done before and is to some persons a very valuable combination, enabling them to do work which they never could do in any other way.

Our friend from New Orleans fairly states his case, and I am convinced is sincere in his convictions.

NEW ORLEANS, Sept. 14, 1883.

DR. C. A. BUCKLIN, New York:

Dear Sir:—Your interesting article in "THE JEWELERS' CIRCULAR" drew my attention to your publication "Detection and Correction of Visual Imperfection," sent to me lately by Mr. Spencer. I read your book very carefully and with great satisfaction; but what you say of "Pebbles" (page 59), is in my opinion premature. I have seen the same repulsive sentence already some 10 years ago in an essay of a French doctor, and concluded that time to investigate into the merits of pebbles some way or other. I take the pleasure, dear doctor, to describe here *one* of my different experiments, and you may judge yourself that the merits of pebbles have not yet been tested sufficiently by scientific men, as the importance of this very object well deserves.

I selected six very sensitive and accurately working thermometers, which I suspended so that neither the temperature of the walls, nor the radiating heat from the street would have any action upon their rising or falling; the outside case was removed leaving only the plate with the glass tube and bulb of mercury. I took then a stiff, straight paste-board, cut into it six equal sized round holes and fastened behind each hole a spectacle lens, all of $\frac{1}{10}$. I selected for this purpose a very common lens quality 3, one white lens quality 1, a faultless pebble, a light smoke, blue and green lens. A suitable screen with a few wires running over it for the support of the six thermometers and the board with lenses in front of them, completed

the preliminary preparations for this rough test. By exposing this contrivance to the direct rays of the sun (after a good many careful adjustments in diverting the focus in each lens to the middle of each mercury ball) the instrument was ready for a test. On a cloudless morning, assisted by a young man with a watch in his hand, I exposed this machine to the action of the sunlight, marking down after 1, 3 and 5 minutes the different heights of the thermometers.

I am sorry that I lost the record of these observations in the course of time, but the result of repeated trials was always that the thermometer behind the pebble was the lowest of all, and that one behind the common white lens was the highest.

Now, dear sir, it is well known to all physiologists that heat is one of the causes of fatigue, and we all know that the eyes get sooner tired by the use of inferior lenses than by a lens of a good quality. If the light transmitted through pebbles is the coolest, I should think the pebbles are preferable to any glass, even to the best one, which transmits more heated rays than pebbles.

I wish, for the benefit of the public at large, this question to be thoroughly investigated by you or other scientific men, and like to see this blundering mistake corrected in all medical books, so often consulted by the trusting opticians.

Very respectfully,

W. SOHNE, Optician.

I give this text he refers to page 59—"Detection and Correction of Visual Imperfections." Remember this was only an expression of my honest convictions to men who are dealing in glasses, and was never published in any "public print."

CHAPTER XII.

SPECTACLES IN GENERAL.

"They are manufactured from glass or native crystal. Where glass is used, pure white glass free from bubbles of air or spots is the best. Natural crystal, commonly called pebbles, should also be free from specks, it is much harder than glass, much more difficult to find, and consequently more expensive. They have only a single advantage over glass, they are so hard that they are not easily scratched. Pebbles disperse the colors stronger than glass, consequently in strong glasses the rainbow colors are much more likely to show in a pebble spectacle than in the purest white optical glass. The only practical advantage of pebbles over glass which has always kept them in the American and English market is, they enable us with all honesty to gratify persons who do not know what they want, but simply wish to pay more than the usual price or more than their friend did for their spectacles."

Pebbles justly gained their prestige over glass in the days when we did not know how to make perfect plate glass; we now, however, make plate glass of such a uniform density. It is a well-known fact that a lens ground with the same surfaces from a pebble is a little stronger than a glass lens having same surfaces. The chromatic aberration of a pebble lens is greater than of a glass lens. Heat rays will not penetrate or pass through a pebble lens as freely as a glass lens. This fact I know to be so although the rude experiment made to demonstrate the fact would not give like results at different observations, one thermometer standing very possibly in the light focus of the lens, while the other was just far enough away to fall in the heat or chemical focus of the lens, widely varying results must be the result of this experiment.

The fact claimed, however, remains true; heat rays do not pass through natural crystal as readily as they pass through glass. This is, however, true of green bottle glass and many specimens of glass which in optical properties are decidedly inferior to plate glass. A pebble being so hard to grind is much more liable to have irregularities in its curve surfaces than a glass lens, which grinds so easily, that its spherical surfaces are much more liable to be regular. It is almost impossible to grind complicated lenses from pebbles. The fact that the lens is cooler does not give it an advantage over glass because the lens when worn must become about the same temperature of the vapor constantly escaping from the skin, otherwise the lenses would be constantly covered with condensed vapor.

If one believe that the difference between pebble and glass lenses consists in their not scratching and not allowing the usual amount of

heat rays to pass through their substance, and can really convince himself that these advantages are decided, no one will object to his advocating pebbles. I never have been able to convince myself of their practical advantage—unless it be in a case where the lenses prescribed can be worn a long time without change, and the person is going to a region where he cannot duplicate his glasses; in such a case they have a *practical* advantage, they do not scratch, neither do they break easily. The author has proposed an optical device for correcting visual defects, a full description of which will soon appear.

Clock Trains.

Continued from Page 317.

Second Example.—To find the number of teeth in a train of 5 wheels, of which the latter pinion is to make 4,400 revolutions:

The pinions having been assumed at 10, 8, 8, 6, 6, their product will be $10 \times 8 \times 8 \times 6 \times 6 = 23,040$. This result is to be multiplied with the given number of revolutions— $23,040 \times 4,400 = 101,376,000$; let us next find the prime factors:

Divisor.	Quotients.	Divisor.	Quotients.
101,376,000	$\div 2 = 50,688,000$	99,000	$\div 2 = 49,500$
	$\div 2 = 25,344,000$		$\div 2 = 24,750$
	$\div 2 = 12,762,000$		$\div 2 = 12,375$
	$\div 2 = 6,336,000$		$\div 3 = 4,125$
	$\div 2 = 3,168,000$		$\div 3 = 1,375$
	$\div 2 = 1,584,000$		$\div 5 = 275$
	$\div 2 = 792,000$		$\div 5 = 55$
	$\div 2 = 396,000$		$\div 5 = 11$
	$\div 2 = 198,000$		$\div 1 = 1$
	$\div 2 = 99,000$		

The following 5 portions may be made from these prime factors:

$$\begin{aligned} 5 \times 5 \times 2 &= 50 \\ 5 \times 3 \times 3 &= 45 \\ 11 \times 2 \times 2 &= 44 \\ 2 \times 2 \times 2 \times 2 \times 2 &= 32 \\ 2 \times 2 \times 2 \times 2 \times 2 &= 32 \end{aligned}$$

These results, 50, 45, 44, 32 and 32 give the required number of revolutions for the reason specified further above.

$$\begin{aligned} 50 \div 10 &= 5 \\ 45 \div 8 &= 5\frac{5}{8} \\ 44 \div 8 &= 5\frac{1}{2} \\ 32 \div 6 &= 5\frac{1}{3} \\ 32 \div 6 &= 5\frac{1}{3} \end{aligned}$$

By multiplying these amounts we find the number of revolutions, $5 \times 5\frac{5}{8} \times 5\frac{1}{2} \times 5\frac{1}{3} \times 5\frac{1}{3} = 4,400$.

These prime factors might also be arrayed in another manner, about as follows:

$$\begin{aligned} 11 \times 3 \times 2 &= 66 \\ 5 \times 5 \times 2 &= 50 \\ 5 \times 2 \times 2 \times 2 &= 40 \\ 2 \times 2 \times 2 \times 2 \times 2 &= 32 \\ 3 \times 2 \times 2 \times 2 &= 24 \end{aligned}$$

The same number of revolutions is also produced by these numbers, because

$$\begin{aligned} 66 \div 10 &= 6\frac{3}{5} \\ 50 \div 8 &= 6\frac{1}{4} \\ 40 \div 8 &= 5 \\ 32 \div 6 &= 5\frac{1}{3} \\ 24 \div 6 &= 4 \\ 6\frac{3}{5} \times 6\frac{1}{4} \times 5 \times 5\frac{1}{3} \times 4 &= 4,400 \end{aligned}$$

The above is, therefore, the general method for finding the number of teeth in any train; we add a few examples specially applicable to watches.

2. Calculation of the pinions and wheels, with special application to watches, according to Lepaute.

RULE.—It is immaterial whether a pinion is driven by a wheel, or the latter by the former, the number of the revolutions of the wheel, multiplied with that of its teeth, is equal to the number of revolutions made by the pinion at the same time, multiplied with the number of its leaves, so that the number of the simultaneous revolutions both of the wheel and of the pinion stand to each other in proportion to the number of the teeth.

Let it be supposed that the number of teeth of wheel *A* and of leaves of pinion *F* were expressed by the capitals *A, F*. The number of their simultaneous revolutions, however, were represented by the small letters *a, f*. We then must demonstrate that $a \times A = f \times F$, and consequently, $a : f = F : A$.

1. Since the number of teeth of the wheel have been assumed = *A*, its teeth will gear *A* times into the leaves of the pinion. While, therefore, it makes a number of revolutions, which = *a*, its teeth will seize $a \times A$ into the pinion.

2. *F* representing the number of the pinion leaves, then by each revolution of the pinion a number of leaves which = *F* will gear into the wheel. While, therefore, the pinion makes a number of revolutions, which we express by *f*, its leaves will seize $f \times F$ into the wheel.

But while the wheel and the pinion make their revolutions at the same time, as many teeth of the wheel will gear into the pinion as pinion leaves gear into the wheel. We thereby obtain $a \times A = f \times F$; and if we consider the two terms of the first couplet of this equation as the product of the last terms, and the two terms of the second couplet as the product of the means of a geometric proportion, we obtain $a : f = F : A$, which we proposed from the beginning.

We can see by this demonstration that when we have a train composed of an optional number of wheels and the same number of pinions, which successively gear into each other, the same rule will hold equally good for each part of the train. Let us suppose four wheels, expressed by the four letters *A, B, C, D*, and four pinions, designated by the four letters *F, G, H, I*; let us next designate by the small letters *a, f, g, h, i*, the number of simultaneous revolutions of the wheel *A*, and of the pinions *F, G, H, I*; we will obtain according to the aforementioned proportions for each wheel gearing into its corresponding pinion the four proportions:

1. $a : f = F : A$;
2. $f : g = G : B$;
3. $g : h = H : C$;
4. $h : i = I : D$.

If we multiply these four proportions in their order, that is, the first terms of each proportion among themselves, also the second terms among themselves, according to the rules of arithmetic, by canceling in the antecedents and consequents of each proportion the quantities which are repeated in them; the quantities of the first proportion are reduced to two: *a* and *i*, since the quantities *f, g* and *h* are repeated in the first and second terms of this couplet, and we therefore have the following proportion:

$$a : i = F \times G \times H \times I : A \times B \times C \times D,$$

whence follows the equation:

$$a \times A \times B \times C \times D = i \times F \times G \times H \times I,$$

and therefore:

$$i = \frac{a \times A \times B \times C \times D}{F \times G \times H \times I}$$

or, in other words: the number of the revolution *i* of the last pinion *I* will be equal to the number of the revolutions *a* of the first wheel *A*, multiplied with the product of the number of teeth of all wheels and divided by the product of the numbers of the leaves of all pinions, so that, if we make $a = 1$, that is, if we assume that the wheel *A* makes only one revolution, the result of this equation will give the number of the revolutions *i*, which the pinion *I* accomplishes, while the wheel *A* makes one revolution.

It also follows from this illustration that, if in a train which is to be made, we had one or two wheels and as many pinions more or less than the four which we have assumed in the above example, it would suffice to add to or deduct from the four proportions, which were produced by the course of our demonstration, the requisite number, in order to have only one for each wheel and for each pinion.

After this general rule has been well understood, the student may apply it without exception to the calculation of all trains required for the ordinary wants of horology, as will be seen from the following example:

First Example.—To find the number of wheel teeth and pinion leaves, which the wheels and pinions of a watch are to have, which is to vibrate in seconds, that is, the balance of which is required to make 3,600 vibrations per hour.

Common use has, for watches, established the number of wheels and pinions at four. Let us designate these wheels with the four capital letters, *A, B, C, D*; wheel *A* gears into pinion *G*, which carries the wheel *B*; the second wheel gears into the pinion *H*, which carries the wheel *C*; this third wheel gears into the pinion *I*, which stands in connection with the wheel *D*; this fourth wheel *D* seizes into no pinion, but its motion is intermittedly arrested by each tooth of the escapement part, the construction and effect of which is to be drawn into consideration.

There are three kinds of escapements used in watches: 1. The recoil escapements; 2. The dead beat escapements; 3. The free escapements. In those of the first two classes each tooth of the escape wheel produces two vibrations if the wheel is a single one, that is, if the wheel teeth stand upon the circumference of the wheel; but when the teeth stand alternately upon the two places of the same wheel, such as the pin escapement, each tooth causes only one vibration.

The escapement with free vibrations, such as, for instance, that of Arnold, and that of constant force, permit only one tooth to escape during two vibrations. It is important, therefore, in order to solve the problem which we have propounded, to first come to a definite understanding what kind of escapement we intend to use, because it is an essential factor in the calculation. We are forced, therefore, to give two solutions, each one of which is applicable to each case.

First Case.—That is, when each tooth causes two vibrations. According to the general rule the first couplet of the equation which we desire to ascertain would be:

$$\frac{A \times B \times C \times D}{G \times H \times I}$$

but since each tooth of the wheel *D* produces two vibrations, we must multiply *D* by 2, and this first couplet becomes

$$\frac{A \times B \times C \times 2 D}{G \times H \times I}$$

in consequence of a condition of the problem, however, the watch is to make 3,600 vibrations; this number must, therefore, become the second couplet of the equation, and we obtain

$$\frac{A \times B \times C \times 2 D}{G \times H \times I} = 3,600$$

Now, when we divide the second couplet by 2, in order to liberate *D* of its co-efficient, and by way of multiplication cause the divisor $G \times H \times I$ to pass over into the second couplet, we obtain

$$A \times B \times C \times D = \frac{3,600}{2} \times G \times H \times I,$$

and by performing the division we obtain

$$A \times B \times C \times D = 1,800 \times G \times H \times I.$$

Now, since it stands in our power to give to the pinion any number of leaves we please, we choose for each one the number of 10, whereby our equation becomes transferred into

$$A \times B \times C \times D = 1,800 \times 10 \times 10 \times 10.$$

It is only necessary to decompose these four numbers into all their factors, by dividing them successively with 2 as long as possible, then by 3, and finally by 5, because these are, in this instance, the

smallest divisors which we can employ. In this manner we obtain from 1,800 the divisors 2, 2, 2, 3, 3, 5, 5, to which sum the pinions also contribute each a 2 and a 5, so that all the factors are 2, 2, 2, 3, 3, 5, 5, 2, 5, 2, 5, 2, 5.

If the escapement is to have a vertical wheel, the number of teeth is limited, and must be an odd one. The limits are from 11 to 17. But since among all factors found, we have no number which could form one of these products, we take 3 and 5, which make 15, for the number of teeth of the vertical wheel *D*.

It now only remains to divide the other factors into three portions, the products of which will give the number of the teeth, which the three wheels, *A*, *B*, *C*, are to have.

We divide them in the following manner:

1. $2 \times 2 \times 3 \times 5 = 60$ for wheel *A*;
2. $2 \times 5 \times 5 = 50$ for wheel *B*;
3. $2 \times 2 \times 2 \times 5 = 40$ for wheel *C*.

Our train is therefore composed as follows:

	Teeth.	Pinions.	Revolutions.
A	60		2
B	50	10	6
C	40	10	30
D	15	10	120

But now, since each tooth of the wheel *D* causes two vibrations, we obtain, when we multiply the 120 revolutions with 30, or double the number of teeth, the product of 3,600 vibrations, as was demanded of us.

Second Case.—That is, if the scape-wheel unlocks a tooth at each vibration. The wheel *D* must not then have a co-efficient in the first term of the original equation, and, consequently, the first term of the second number can have no divisor. The equation will then be

$$A \times B \times C \times D = 3,600 \times 10 \times 10 \times 10,$$

and if we proceed as was specified in the first case, we will have a 2 more among the factors than in the preceding case. If we again take the scape wheel with 15 teeth, and each pinion with 10 leaves, we obtain as the number of teeth, *A*=80, *B*=60, *C*=50, *D*=15. By executing the above given operation, we will find that the wheel *D* makes 240 revolutions, while *A* makes 1, and by multiplying 240 with 15, the number of vibrations which the wheel causes by each of its revolutions, we will, as formerly, obtain as product 3,600 vibrations per hour.

REMARKS—If one-half of the scape wheel teeth are upon one place and one-half upon the other place, as by the pin escapement, the calculation may be performed in a two-fold manner. 1. By counting only the teeth upon one side, the calculation is performed as above specified, by giving the co-efficient to wheel *D*. 2. By counting the teeth upon each side and adding them, or multiplying the teeth upon one side with 2, which is the same; the calculation is performed in the latter case without giving a co-efficient to the wheel *D*.

This rule is general and without exception, it being immaterial whatever be the number of the vibrations which the watch is to make. The number at present in use is either 14,000, that is, four vibrations per second, or 18,000 for 5 vibrations per second. It is only necessary to substitute one of these numbers for 3,600, or any other, and to alter the number of leaves according to option; the remaining part of the calculation is entirely as we have specified. The same calculation and the same process must be observed to find the number of teeth and leaves, if the watch or clock is to go longer than 30 hours; for instance, 8 days, 1 month, 1 year. The number of days intended is multiplied with 24—the number of hours—and the equation is formed. Let us suppose the clock was to go 8 days, which is 192 hours, or revolutions which the center wheel *A* must make during one revolution of the wheel *P*, and we obtain the equation: $P \times Q = 192 \times 16 \times 12$, etc., provided that for this case two wheels and two pinions are employed, when the process is as above specified.

(To be Continued.)

Depthings.

[By J. RAMBAL, teacher of Horological School of Geneva, in *Allg. Journ. d. Uhrm.*]

Continued from page 328.

20. The distance of the centers, that is whether they are too close together or too far apart, is a very essential point with depthings. In the first case the tooth will operate at the end of its driving, by means of its fine point, and since this in the last moment slides off very quickly from the pinion leaf, the next following tooth falls upon the leaf to be driven instead of applying itself against it without an injurious drop. If, however, the depthing is too shallow, the driving takes place far too early before the line of centers, and occasions a butting.

The altered tooth curve has the advantage of enlarging the limits, within which a good depthing may take place.

21. At the conclusion of this article we wish to add a method for calculating the measures of a wheel of 60 teeth and a pinion of 6 leaves, whereby the distance of centers is supposed with 3.75 millimeters, which would approximate the scape wheel depthing of a 13 line watch.

Since, now, the proportion between the pitch radius and the number of teeth must be retained, the pitch radius of each part will require a length of the center line in tenor with the tooth number. We therefore will use for the wheel $\frac{60}{66}$ of this distance, while the other $\frac{6}{66}$ remain for the pinion. It will be seen that the denominator of these fractions is obtained by adding the number of teeth and leaves. Therefore is

$$\frac{60 \times 3.75}{66} = 3.409$$

the pitch radius of the wheel, and

$$\frac{6 \times 3.75}{66} = 0.341$$

the pitch diameter of the pinion.

The height of the addendum of the tooth was a part of the pitch radius of the pinion, and it is found according to the table given heretofore. $0.341 \times 0.512 = 0.17459$ = the height of the addendum. Also is the full radius of the wheel equal to the pitch radius, increased by the height of the addendum, we therefore have: $3.409 + 0.17459 = 3.58359$ as full radius of the wheel, and $3.58359 \times 2 = 7.167$ millimeters as full diameter of the wheel.

As we have assumed a semi-circular rounding for the pinion leaf, we obtain the full diameter of the pinion by adding one-half the size of pinion to the pitch radius.

The thickness of a pinion leaf is found by calculating the length of the pitch circumference, after which this length is divided according to the number of leaves and their proportion to the interval.

By proceeding in the indicated manner, it will be found that also the full diameter will be obtained if the pitch diameter were to be multiplied with a proportionate number which is unchangeable for one and the same number of pinion leaves. (For 6 leaf pinions this proportion is 2.349.) We therefore have $0.341 \times 2.349 = 0.801$ as the full diameter of the pinion.

The proportion between the full measurements of wheel and pinion, which was mentioned previously in this article, is obtained by dividing the full wheel diameter with that of the pinion. Therefore 7.167 divided by $0.801 = 8.95$ is the proportion between wheel and pinion.

These calculations offer no difficulties whatever for readers who desire to examine this matter more thoroughly, and for this purpose we would recommend the labors of the late Swiss, H. Schouffelberger, "Ten tables for ascertaining the magnitude of wheel and pinion." Also a table of corrections for proportional circles will be found in it, together with directions on the use of this instrument.

Since the tables given by Schouffelberger are on the basis of the uniformity of tooth and space, and calculated for the epicycloidal curve, it will be found that the value given in them for above-stated

example will be a little smaller than that given by us. The full diameter of the wheel, therefore, amounts to 7.135 in place of 7.167, and the difference amounts to about three hundred millimeters, which is only due to the smallest height of the addendum.—*Journal suisse d'Horlogerie*

[THE END]

The New Time Standard.

SINCE THE adoption of standard time in this country, about 400 applications have been filed with the patent office for clock dials and other devices intended to present the 24 hours in a convenient form. A large number of these applications have been rejected, upon evidence found in a musty old volume that Prince Soltykoff once possessed a watch, made in the year 1547, upon the dial of which appeared the hours from 1 to 24, arranged in two concentric circles, so that the applicant for a patent was 100 late by 336 years.

* * *

Judge Holmes, of the Mass. Supreme Court, in the case of Clapp against Jenkins, directed a writ of prohibition to issue against the defendant to prevent him from further proceedings against the plaintiff under the poor debtor law. Clapp was cited to appear before Jenkins, Commissioner of Insolvency, Nov. 19, between 9 and 10 A. M. On the morning of Nov. 19 Clapp appeared at the office of Jenkins at 9.45, according to the new time. The magistrate refused to recognize the new time standard, and as it was 10.01 by the old time Jenkins defaulted the debtor. Judge Holmes decided that Clapp had a right to be governed by the new standard, which, by its universal adoption, became the usage of the community the day it went into effect.

* * *

The Detroit *Evening Journal* is the first newspaper to follow the example of the Cleveland, Mount Vernon and Delaware Railroad and schedule its operations by "sidereal time," or what is otherwise called the twenty-four o'clock idea. Our venturesome contemporary seems to have been captivated by the recent expositions of the practical advantages of this idea, and will henceforth issue its afternoon editions at fourteen o'clock, fifteen o'clock and seventeen o'clock, and ring up the local stage curtains at twenty o'clock. As its tendency to prevent collisions is alleged to be its principal recommendation for railroads, it is to be hoped that this innovation may have a correspondingly pacific influence upon the journalism of Detroit.

* * *

The scene is a German corner-grocery. It is 8 o'clock in the evening. An Irish workingman is finishing some small purchases, and the blue-eyed, good-humored Teuton is disposed to be entertaining to his customer. Dennis delivers himself thus: "It's a dale curious, now, ain't it, about the toime! We've lost foive minutes in the shop, an' the boss sets the ould clock back and rings the bell at 12 o'clock, foive minutes ahead. So it's noon, and it aint noon, by foive minutes all at once! Now wat d'ye say to that?"

The Teuton smiles blandly: "Vy, I shoost say to dot, somebodies foolin' dot boss; else mebbe he's took grazy like—vot you calls grank! Dwelve a'glock's dwelve a'glock every time, an' don' you vorgit!"

"But," says Dennis, "it's all down in the paypers, and there's a divil of a fuss and bother forninst the whole bizniss. Shure an' there's a dead loss of foive minutes somehow!"

The argument doesn't convince the unimpressive Teuton: "Daint no such ding! Dem noosebapers is all a pack o' lies, don' you vorgit, vell! No vide-awake man dakes stock in dem lying bapers!"

Dennis reddens up: "Ony hoo, the five minutes is gone shure, faith! and I'd loike to know how they shlypt out. And I hear it's in all the paypers."

"Dem noosebapers," shouted the smiling salesman, "I say, is all a pack o' lies, every vun; you shoost mind. Dot glock up dere, you sees, he goes dick, dick mit mine vader twenty years in Chermenny, all de same. I pring him here. He aint lost no dime! Shoost put dot behind your pack, my vrend. Can't lost no vife minnits, dots blane enuff! It's all a shoke, I guess!"

Dennis, with a dazed look, takes his parcel and beats a retreat.

* * *

Owing to the universal adoption of the new standard time in this city, the regulation of the immense number of public and private clocks that are regularly cared for by experts from the various large establishments in the city was necessary. The city time is regulated by a paid official, and the time of the Stock Exchange by Mr. Ladd. More than 400 clocks each are regulated by Tiffany & Co. and Benedict Brothers. Most of these are private clocks, varying in value from \$100 to \$1,500, and they are regulated every week. Mr. Lindauer of Tiffany & Co. said: "We regulate fine clocks in the houses of Mr. William H. Vanderbilt and his son, Mr. William K. Vanderbilt. The Messrs. Lorillard have exquisite clocks, which we will regulate, and so have the Astors. The finest and most expensive clock in the country is that in the Parker house, at Sixth avenue and Thirty-second street. It has a clear ringing Westminster chime of great value. It registers the movements of the planets, the rise and fall of the tides, and does not miss leap year, so perfect is its calendar. It marks sunrise and sunset, and gives the time in the principal places in the world. It is something of a job to set that clock. Then Mr. Brown, the carriage manufacturer, has a superb clock with chimes in his residence, at 49 West Thirty-second street. These four little minutes mean a great deal of careful work for us, and it will be several days before the task is accomplished."

Mr. W. E. Taylor of the Ansonia Clock Company, who has charge of the clocks regulated by Benedict Brothers, said: "We wind, regulate, and keep in repair about 450 clocks. Some of these clocks control the motions of a great many people, such as the clocks of the New Jersey Central, the Delaware and Lackawanna, the American Express Company, Altman, Macy, McCreery, and other large stores where large numbers of men are employed. Take the Delamater Iron Works, for instance, where there are 900 men. If the clock varies a minute a day, the variation in the time of the force employed is equal to the time of one man for a day and a half. When I went to put the clock back to meet the standard time, the men said I ought to have gone in the morning when they began work. We generally wind our clocks once a week. It is a common thing for me to wind and regulate about 120 clocks in a day. I believe old Mr. Benedict was the first to make a business of winding clocks, and, although Mr. Hammond and Mr. Ladd have charge of a considerable number, the greater portion of bankers', brokers' and insurance offices' clocks down town are attended to by the Benedicts. If you have a nice clock, it pays in the long run to have it handled only by an expert. A bungler can do a good deal of damage to a fine clock in a very short time."

How to Make and Engrave Silver Bangles.

BY EXPERT.

IN MY description in last number of the machine for frosting or matting the surface of bangles, I left the machine with the vibrators made and ready to go into the holes in which they were to vibrate, but did not show any mechanism for holding them in place, or rather to keep them from being blown out. At *A*, figs. 1 and 2, are shown the brass cylinder spoken of in my last number, and shown in the cut of that number at *M*. This is pierced in the direction of its axis with 16 hooks as shown in fig. 2. At *c*, fig. 1, is shown one of the vibrators with its matting needle *d*; at *a*, *b*, are shown the stopping pieces for arresting the motion of the vibrator *c*. One of these

pieces is shown enlarged at fig. 3; it will be seen that it is merely a strip of brass extending between two rows of holes and secured to *A* by small screws. These pieces should extend over the holes only enough to securely stop the vibrator *c* at each end of its motion. In fig. 3 *a a* represents the strip, and *c c* the vibrators. Of course it is understood that strips *a* and *b* are alike and secured alike, except one is on the top and the other on the bottom of the piece *A*. At fig. 4 is shown an elevation of the complete machine standing on the bed piece *C*, *f* indicating the needles in the vibrators. The points of these needles can be varied in shape for producing different surfaces; the form shown at *D* (magnified), is about what is required for bangle and jewelry work, in conjunction with the change of the length of stroke of the piston described in last article.

This is further illustrated at *E*, where the pulley shown at *i*, fig. 4, is shown enlarged. In this diagram *j* shows the center, *g* the holes for the crank-pin screw, which will be seen on inspection to gradually sweep away in a curve from the center *j*. For the benefit of any mezzo-tint engraver who may wish to use such a machine for laying grounds, I would say grind the point of the needle chisel-shape as shown at *F*, and it will make an incision shaped as shown at *n*, and a very even ground, far superior to hand laid grounds. The manner of using the frosting machine is to put say a dime into a piece of brass as shown at *B*, where *c* represents the dime to be frosted; and the part *k* can be used as a handle to move the dime about under the needle points shown at *f*, fig. 4. The needle points

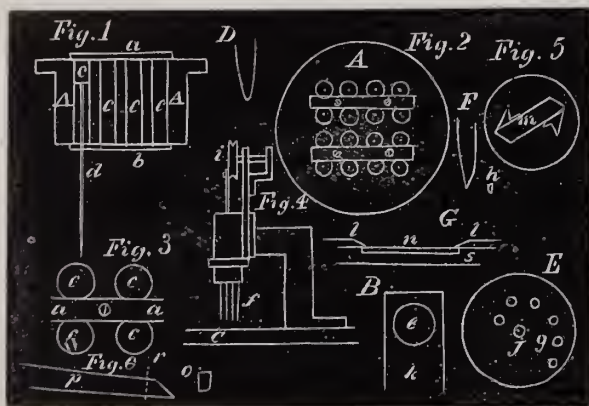

should be set so they will just reach the surface of the dime, and the motion of the piece *k* should be quite rapid as one can readily see, as the needles at *f* each strike the face of the dime about 150 times in one second; but still the slight side shake to the vibrator *c* will prevent the points striking exactly twice in a place if the coin is moved any way rapidly. Many ornamental effects can be made by covering a portion of the face of the dime with some protecting substance, as for instance in fig. 5 the scroll *m* could be cut out of paper and gummed on; this would protect the surface of the dime, and when the paper was washed off the polished scroll would be bright and clean and could be used as a panel for a name. The margin lines could be cut with a graver and a very clean, bright effect obtained. For such surfaces as require no bright polished panels or the like, the dime needs no polish it being quite smooth enough from the lathe for the frosting. Gum shellac, if the vibrators are light enough (say made of ivory as suggested in former article), will protect the surface. The gum should be dissolved in alcohol, and if allowed to dry to the right consistence will perfectly protect the surface. But for all ordinary work paper gummed on one side like a postage stamp, and cut to shape and wet and applied to the surface answers best. For the common cheap monogram, take the surface from the lathe, frost and engrave it, and it is done in less time than a good polish can be obtained. In turning off the face when it is to be frosted the raised margin of the dime can be left, and the dime put under a cover to protect the edge as shown at *G*, where *s* represents the holder shown at *B*; *l* a level edged cover and *n* the dime. This cover is simply a thin piece of brass with a hole cut through of the size of the flat part of the dime. The cut at *G* shows the

method; it will be seen that the sloping surface at *l* extends over the outer and raised edge of the dime so the frosting needles only roughen or frost the flat surface turned off on the dime. There is no reason why the motion to the piece *k* could not be automatic, and the dime moved about under the needles at *f*, fig. 4, either regular or with an irregular movement; but such mechanism would hardly pay for the work, as one soon gets accustomed to it and can quickly frost a dime—one or two minutes even for the finest surface being ample time. The points of the needle *d*, fig. 1, can be made of iridium or even small splinters of diamond; but a blunted steel point nicely polished for bangles and jewelry is quite good enough. In engraving on frosted or matted surfaces the graver should be polished as bright as possible, and all the cuts made clean without any ragged edges. Gold coins can be colored after they are frosted and then the bright cutting shows to great advantage. Sometimes certain designs in broad effects on large surfaces (by large here I mean something larger than a dime, or from the size of a quarter up), can be engraved before the frosting. Such work is difficult to show with a wood cut, as it needs a metallic surface to give an idea of the effect. The idea is to cut into the surface to be matted broad lines and leaves, then going over the surface with the needles produces an effect similar to relief; in fact it bears the same relation to relief that intaglio does to cameo. I only refer to this as an idea, and give it a mere passing consideration, for it will only succeed in the hands of a skillful designer and engraver. Round bottom and flat bottom gravers are the ones to use in such work. The flat bottom ones have the angles ground off as shown in fig. 6, where *o* is a transverse section of *p* on the line *r*. Such gravers are of great value in broad leaves and for all kinds of bright cutting as well as for the purpose just spoken of.

It is well for persons who have ambitious views in engraving to study the samples of such work that our traveling men have, although the goods may be such as one would not feel justified in purchasing. When you see a job of ornamental engraving on any piece of jewelry, ask yourself how was this effect produced, and how was the graver managed to get this or that result. And if you see any design that you think can be of use to you make a rapid hand sketch of it; no traveling man would object even if you were only a moderate customer. But of course judgment should be used in trespassing on the patience of the *best natured fellows in the world*.

[Copyright Secured.]

The Cup—Its Art and Customs.

[BY JOHN W. MILES.]

Continued from page 349.

DURING THE Middle Ages the church was the mother of the arts, and articles in gold and silver were produced almost exclusively in the monasteries and by the monks. Thus the best part of the art work of that period was devoted to the service of the church, and was not only rich and elaborate but also of a quantity so immense as to be almost beyond belief. This abundance continued until the Reformation. In 847 it was decreed by the council of Rheims that chalices should be of pure silver, if not of gold, and no other material was allowed, except where gold or silver could not be obtained, when tin might be used, but it is doubtful if any church at that time was without a considerable store of the precious metals.

From the 11th to the 13th centuries the prevailing style of ornamentation remained the same, but some attempts were made to acquire more beauty of form. The bowls were half globes resting upon a large round base, while, for the greater convenience of the celebrante, the stem had a knob also decorated. Such is the chalice of St. Remigius, preserved in the national library in Paris, figure 19. It is of gold bound round with enameled bands of filigree gold and inlaid with precious stones. It is a beautiful example of the late

Romanesque style. These gold and enameled chalices were often made with two handles, as in the illustration of the one from Wilton

sides, and with an unusually large knop. The foot bears four circular medallions, in which are represented the Annunciation, the Nativity, the Scourging of the Lord, and the Crucifixion. The second example, figure 23, is a German chalice, also of silver gilt,



Cup of St. Remigius, Figure 19.

in Tyrol, dating at the end of the 12th century, figure 20; but handles appear to have been abandoned about this time. Passing rap-



Chalice of Gold and Enamel, Figure 20.

idly over ground so nearly barren of objects which have escaped destruction, we arrive in the 13th century at the Gothic period, and the influence of an increased appreciation of the beautiful becomes at once apparent. The bowl assumes a more symmetrical shape, and the redundant ornamentation is largely restricted. Here also occurs two centuries with but little change. The chalice of the 13th century, figure 21, still bearing emblems of christianity, which were

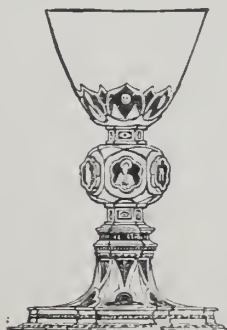

13th Century Chalice, Figure 21.

never entirely abandoned, nevertheless exhibits a refinement and grace in the shape of the bowl greatly in advance of the previous illustrations. Here appears also an effort after architectural effects with but a slight subordination of design to the uses of the article. For the 14th century we have three examples. The first, figure 22, of French manufacture, is of silver gilt, with straight funnel-shaped



Figure 22, French.

Figure 23, German.

Figure 24, Italian.

14th Century Chalices.

and nearly as tall as the French illustration ($6\frac{7}{8}$ inches). The cup is round, with a six-sided stem and a six-foiled foot. The cresting is decorated with hammered work of rich foliage, representing alternately tall and short leaves. The third and last example of 14th century ecclesiastical work is from Italy, figure 24. It is $8\frac{5}{8}$ inches in height, with an egg-shaped cup and with a round stem checkered in lozenges, which are covered with translucent enamel. Around the spring of the stem at the foot is a circle of angels in relief. The foot is round, having a band of milled work at its outer edge, while its upper surface is covered with circular medallions. The influence of the Gothic period upon art work in silver and gold was exceed-

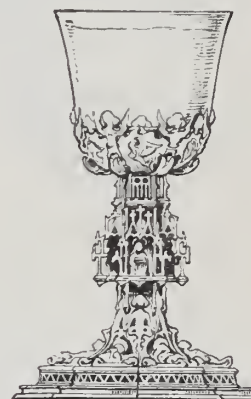

15th Century Chalice, Figure 25.

ingly strong. Architectural decoration was applied to almost every object, and the results were often rich and effective. Small niches surmounted with the pointed arch and surrounded with elaborate tabernacle work served to contain figures of saints or apostles, while the plain surfaces were covered with the most beautiful enameling. A silver gilt chalice of the 15th century, figure 25, is one of the finest examples of the extent to which this style was carried. The entire chalice from bowl to base is one mass of rich architectural design, elaborately worked out with the most careful attention to details and



Spanish Chalice, A. D. 1549, Figure 26.

abundantly supplied with church emblems. The lapse of another century brings us to the renaissance, when the influence of higher taste and more beautiful designs revolutionized ecclesiastical art. In

countries where the Reformation obtained the strongest foothold we find a substitution of simpler forms and cheaper materials, but in Italy and Spain the church still retained articles of great magnificence, and made constant additions of works bearing the high standard belonging to the period. Such is the Spanish chalice represented in figure 26. But religious art, which had fostered the cultivation of taste through the legathic centuries of the Middle Ages, had accomplished its mission. From about 1450 gold and silver work was no longer confined to the monasteries. Goldsmiths' guilds had been established, and, becoming strong in both material wealth and in talent, produced large quantities of plate for secular uses.

Returning to household utensils we must not forget that other nations, Britain, Gaul, etc., each had their style of cups and goblets

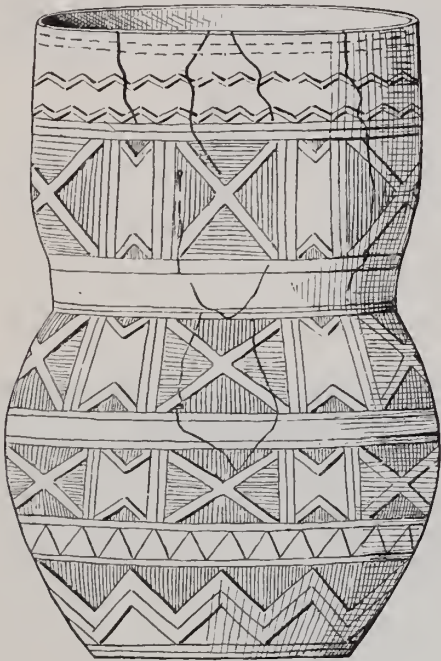

British Cup (Stone Age), Figure 27.

before either Greek or Roman influence was felt by them. In fact cups have been found in British tumuli believed to belong to the anti-metallic period. They are 6½ to 9 inches high, globular below, contracted in the middle and expanding at the top, figure 27. They were carefully formed by hand of fine clay tempered with sharp sand and well baked. They were generally ornamented with the popular parallel and zig-zag lines. A vinous liquor extracted from honey called mead was the usual drink among the ancient Celts, and it was not uncommon to take it from the skull of a slain enemy. Warnefrid, in *De Gestis Longobard*, says: "Albin slew Cuminum, and, having carried away his head, converted it into a drinking vessel,



Horn of Ulphus, Figure 28.

which kind of cup with us is called Schala." The same thing is said of the Boii by Livy, of the Scythians by Herodotus, of the Scordisci by Rufus Festus, of the Gauls by Diodorus Siculus and of the Celts by Silius Italicus. The custom is proven by chronicles to have been in use as late as the 10th century. The drinking horn was a popular utensil in the early days of nearly every nation, and the Anglo-Saxons were no exception to the rule. They lived in constant fear of poison, and usually provided covers for all utensils into which poison might be introduced. Meats and drinks were tasted by the server before they were partaken of by the master, and eventually small cups called "cups of assay" were used for this purpose. Not

only that, but it was believed that certain substances had the property of detecting poison. Turquoises were supposed to turn a paler blue, crystals to become clouded and horn to evince agitation in the presence of poison. Hence these substances were often used in some portion of the cups, and the popularity of the drinking horn may have been due to this superstition. Representations of the horn frequently occur in the illuminations, and it was undoubtedly in common use. Perhaps the earliest specimen of these extant is the Horn of Ulphus (Wulf) preserved in the Cathedral of York, figure 28.

The tankard was also extensively used. This cup was of considerable size, holding two or three quarts. They sometimes had a whistle attached to the brim, which could be sounded when the cup required replenishing. In rare cases the whistle was ingeniously contrived to sound its own note when the cup was empty. In order to restrain the intemperance consequent upon drinking from so large a vessel as the tankard, King Edgar, in the 10th century, ordained that pins or nails should be fastened into the cups or horns at stated intervals, and whoso should drink beyond these marks should be punished. Thus arose the famous Peg-Tankard, which eventually defeated its own object. The one illustrated here, figure 29, is in



Peg Tankard, Figure 29.

the Ashmolean Museum at Oxford, and belongs to the 15th century. It is of wood and very light weight. It holds two quarts, and has on the inside a row of eight pins, one above the other. This would give to each person drinking a gill of liquor, the first drinking to the top peg, the second to the next, and so on. It was often arranged, however, that if one drank short of the peg or beyond it he was obliged to drink again, hence if he chose to intentionally miscalculate he might drink the entire contents. The consequences of two or three such errors can be imagined. In fact so greatly did the use of this cup increase dissipation that the priests, who appear to have been *par excellence* the *bon vivants* of the day, were enjoined by the canons of Archbishop Anselm not to attend drinking bouts or "drink to pegs."

(To be Continued.)

Sir William Siemens.

THERE ARE but few occasions when THE CIRCULAR will step outside of its plainly defined path to take cognizance of anything save that which belongs to its own proper sphere. It departs

from this, its well-known custom, to chronicle the death of a man who did not pertain to one profession or nation, but who was in his life the preceptor of science and trade and the citizen of every clime, who was a great man in the sense in which Humboldt, and Watt, and Faraday, and Arago were great, we speak of Sir William Siemens, who departed this life on the 19th of November last, and who has left an indelible impress upon the science and industry of his age and of the future.

Sir William Siemens was returning from a meeting of the Royal Institution, when not noticing in time the curbstone of a pavement after crossing a street, fell heavily with his left arm under him; he was a good deal shaken by the fall; the next and several successive days, however, he attended to his duties. But the exertion proved too great, and he was compelled to lay up. The injury inflicted gradually assumed graver proportions, congestion of the lungs set in, pain of the heart, etc., which culminated in his death.

Sir William Siemens was perhaps one of the most indefatigable workers of England. His secretary was with him at nine o'clock very nearly every working day of the year; there was work for one society or another to be done, proofs of the abstracts of the Institution of Civil Engineers to be examined, letters or opinions on scientific subjects to be dictated, frequently also specifications of new inventions already schemed out. Then followed the walk across the park almost at racing speed to Westminster, where he had his office; the business of the Landore-Siemens Steel Company; of Messrs. Siemens Bros. & Co., Limited (of both which large undertakings he was chairman); the work in connection with the furnaces and metallurgical operations of which he was the inventor; visitors and inquirers to be seen, and in the afternoons attendance at council meetings of the learned societies or directors' meetings of various companies. The evenings, again, were spent at one or other of the learned societies. This gives a faint idea only of the way Sir William Siemens passed his weeks, and months, and years. Little wonder, then, that he broke down when he was just over sixty years.

It is useless to longer dwell upon the incredible quantity of work daily performed by him. He was heart and soul and mind an engineer, and an embodiment of his own great subject of ENERGY.

Charles William Siemens was born in Leathe, Hanover, April 4, 1823; he received his early education at Lübeck, and at the Polytechnic school at Magdeburg. In 1841 and 1842 he studied at the University of Göttingen, where he had the good fortune to sit under Professors Wöhler and Himly, and thus at nineteen years of age his academical career came to an end, shortly after which he went to England.

When barely twenty years of age he was brought into notice by the invention of a process of electro-gilding, which had been made by him and his brother, Dr. Werner Siemens, then a young lieutenant of artillery in the Prussian service. He afterward became a favorite of Faraday, by which means he was introduced into scientific circles.

We would enter into the most puzzling of labyrinths were we even to faintly trace out a part of the scientific work performed by Sir William. The task would exceed the limits of THE CIRCULAR, and we are forced to refer the student to other sources, while we concur in the general expressions of sorrow coming from all parts of the world, wherever science and industry flourish. Sir William died at a premature age, yet with fully deserved honors thick upon his brow, and he was at least not compelled to grieve at the tardy recognition of merit by the world which is oftentimes so niggardly doled out to other great minds.

BRONZING IRON.—The article should be heated to a greater degree than the hand can bear, and German gold, mixed with a small quantity of spirits of wine varnish, spread over it with a pencil; should the iron be already polished, you must heat it well, and moisten it with a linen rag dipped in vinegar.

The Jewelers' League.

President, GILBERT T. WOGLOM.....Of Woglom & Miller.
First Vice-President, JAMES P. SNOW.....Of G. & S. Owen & Co.
Second Vice-President, HENRY HAVES.....Of Wheeler, Parsons & Hayes.
Third Vice-President, WM. C. KIMBALL.....Of H. F. Barrows & Co.
Fourth Vice-President, AUG. KIRTZBORN.....Of L. Bauman Jewelry Co. St. Louis, Mo.
Secretary and Treasurer, WILLIAM L. SEXTON.....Of Sexton & Cole.

EXECUTIVE COMMITTEE.

JOHN D. LYON, *Chairman*.....Of Lyon & Hardy.
 JOSEPH B. BOWDEN.....Of J. B. Bowden & Co.
 JAMES D. YERRINGTON.....Of J. D. Yerrington & Co.
 ROBERT A. JOHNSON.....Of Colby & Johnson.
 SAMUEL W. SAXTON.....Of Saxton, Smith & Co.
 CLEMENT B. BISHOP.....Of Carrow, Bishop & Co.

EXAMINING FINANCE COMMITTEE.

CHARLES G. LEWIS.....Of Randel, Baremore & Billings.
 CHAS. G. ALFORD.....Of C. G. Alford & Co.
 GEORGE R. HOWE.....Of Carter, Sloan & Co.

THE JEWELERS' CIRCULAR is the *exclusive* official paper of the Jewelers' League, and has been selected for the publication of all matters of interest pertaining thereto. Letters or inquiries pertinent to its business or purposes, and which might interest the trade or inquirers, will herein be answered. Address *Jewelers' League, Box 3,444, P. O., New York*, or the office of THE CIRCULAR.

The Commercial Traveler, the organ of the Commercial Travelers' Association of the State of New York, in its November number says: "Five of the officers of the Jewelers' League are members of the C. T. A. of New York, namely: Gilbert T. Woglom, President; Wm. C. Kimball, Vice-President; Wm. L. Sexton, Secretary and Treasurer, and Messrs. James D. Yerrington and Clement B. Bishop of the Executive Committee." Yes, dear *Commercial Traveler*, but you left out Vice-President James P. Snow, and if you would look over the roll of members you would find a host of those who give willing allegiance to their *Alma Mater*, the C. T. A. One of the resolutions passed at the founding of the League, May 26th, 1877, was: "That our efforts be toward the forming of an association or league, which, in all its intents, purposes and interests, shall be brother to the Commercial Travelers' Association of the State of New York," and the result is the existence of a brother (we were about to write big brother, but with a membership of 3,000 we will modestly wait a few months more), at least of a sturdy one with an identity of interest which cements the two in a friendly brotherhood. If our readers had been at Albany during the winters of 1881 and 1882, they would have seen these two brothers shoulder to shoulder, knowing, like Ben Butler's widow, just what they wanted, and not afraid to ask for it; it is not recorded whether the widow secured her chap, but history goes further with these brothers, for they got what they wanted, namely, Chap. 256 and Chap. 175 of the Laws of 1881 and 1883 respectively.

On November 28th, the beneficiary of L. A. Cuppia was paid \$5,000, making the total payments to the widows and orphans of deceased members \$68,777.60. The magnitude of the purposes of the League may be appreciated by the knowledge that with the present membership, the benefits aggregate fifteen millions of dollars, or in insurance phraseology, the League is now insuring to the extent of fifteen millions of dollars.

William P. Jones, of Newburyport, is another of the milestones in the progress of the League, his membership number being 3,000.

The advantages of the plans adopted by the League may be demonstrated by showing their availability as they appear to men willing to avail themselves of them. The plan of the "old line" life insurance companies has been to fix the annual cost of insurance at sums graduated according to the ages of the insured at the time of their entrance, such sums to be paid uniformly each year throughout the life of the insured. That sum, or annual premium as it is called, is based upon their experiences of mortality, but the superstructure of annual premiums towers away above the base and is termed "loading," one purpose of which is for the expense of management, the other for the accumulation of a large reserve; for these two purposes the loading is uniformly 37½ per cent. more than the cost of the insurance. The "expense of management" we can readily under-

stand, especially if we pronounce it as if printed "expensive management." The "reserve" loading is in order to counterbalance the excessive cheapness of pure insurance in early life (viz.: cost, plus the expense of management), and is accomplished by taking from the insured a sum per annum larger than is requisite for the united purposes of insurance and expenses. Pure insurance was primitively so defective in its adjustment as not to be self-supporting as a business, and therefore a charge for insurance was made far above its costs, *i. e.*, loaded, part of the surplus creating a capital for a banking business, the profit of which was to supplement the deficit in the insurance department and relieve the insured from what might be burdensome rates in later life. We venture the assertion that, massing the mutual benefit associations with the old line life insurance companies of this country, there have been more serious wrecks caused by reckless banking than by defective insurance. The mutual benefit associations do not tax the young man because he is young, but leave with him this excess or "load" to be used as he sees fit, depending upon the good faith of the members, one toward the other, to pay later on what it actually costs to carry their risk, which, as shown in the last number of THE JEWELERS' CIRCULAR, will not even then be burdensome for the benefit secured. Now, if any of the members want to be better assured of their ability to carry their risks when they are older, and, in fact, more certain than if insured in the average old line company, let them go to the association that gives pure and simple insurance for their insurance, and to the institution that does pure and simple banking for their banking. No system of insurance can insure its patrons that its large accumulation of funds will be honestly and judiciously managed. (We do not wish to be understood as being averse to any fund whatever; we firmly believe in an adequate fund for use in possible adverse contingencies, and we hope the League may yet realize the importance of raising and having such a fund), but let the member who wishing to assure his insurance set aside each year the difference between his actual payments to the League, and the amount he would pay an old line company for the same amount of insurance at his current age, and deposit that difference regularly in a sound savings bank, and he will realize what it is to be a member of a mutual benefit association, having his own reserves and security where he can count and control them himself. One curious phase of trustful human nature is developed in the present system of security, become obsolete years ago in the banking interest, but as practised by the life insurance interest to-day: the old liner promises to pay, and as a guaranty asserts its assets and securities, but oddly enough, the promise to pay is made by the same party that holds the security; the security is held by the maker of the promise to pay, but not by the party who accepts the promise. The constituents of the old liners are very much like the apprehensive farmer who exacted a note from a tricky debtor, and in order that the debtor might be sure to remember the time when payable, the farmer insisted on the debtor holding his own note. The membership of the League is now sufficient to pay \$5,000 net for each death; during the last year there were four assessments, aggregating \$8. The premiums paid by a man between 25 and 30 years of age for an insurance of \$5,000 in a reputable insurance company would average for that *quinquennium* \$104.77; between the ages of 30 and 40 a man will have paid for that *decennium* an average annual premium of \$130.79; and from 40 to 45 years, an annual average premium of \$169; the members, therefore, who last year aged between 25 and 30 each saved \$96.77; those between 30 and 40 each saved \$122.79; and those between 40 and 45 each saved \$161; a member in the first-named *quinquennium* investing the saving of last year alone at the moderate interest of 4 per centum, when arrived at the age of 60 will be in possession of a reserve fund at simple interest, of \$224.48; a member in the *decennium* 30 to 40 years of age having saved and deposited his \$122.79 in a savings bank paying 4 per centum annually, will, when arrived at the age of 60, have a fund of his own of \$361.58; while a member in the *quinquennium* 40 to 45 years of age, if he had deposited the

amount he saved last year only, would have at the age of 60 at 4 per centum, simple interest, the sum of \$290. It will need but little further consideration of this line of thought to show that there are great possibilities in the plans of the League to those willing to avail themselves of them, by laying aside each successive year the amount they have saved by payments less than the premiums they would have paid an old line company for the same amount of insurance.

Within the past few months there have been many queries as to whether the League would pay a benefit of \$5,000 net, or \$5,000 less 5 per centum. The League does not guarantee the payment of \$5,000 absolutely, but promises the sum of two dollars from each member, less 5 per cent., not exceeding \$5,000. This latter provision was made in anticipation of the time, now arrived, when (the membership becoming so numerous that one assessment produces a sum in excess of \$5,000 benefit and the secretary's fees), the excesses would remain in the death-loss fund until the aggregate of such excesses would pay a death loss; the time is not far distant when, under the present laws, a death benefit will be paid without assessing for it.

The following is the text of a letter recently received by Secretary Sexton: "At the time of the receipt of the check from the Jewelers' League I was so prostrated I was not able to send even a word of thanks. * * * * I hope it is not too late now for me to assure you of my deep gratitude to the League for its prompt and generous payment to me. I do thank you more than I can express. May God bless the Jewelers' League with richest blessings, is the prayer of one who will ever take a deep interest in it." Signed by the widow of a recently deceased member.

At the regular meeting of the Executive Committee, held on Dec. 7th, there were in attendance Doctor Wilbur, Committeemen Yerrington, Bishop, Saxton, Bowden and Johnson, Secretary Sexton, Vice-President Kimball and President Woglom.

A Special Committee was authorized to engage for the annual meeting, on January 15th next, Horticultural Hall, situated on 28th street near Broadway.

The Committee was notified of proposed amendments to the Constitution providing for an additional section of membership, with a limited benefit of \$1,000, and the assessments to be graduated according to age in that section. Also to provide a "contingent fund" to be used in the present membership in case the death rate should exceed the normal death rate in any one year, by drawing on that fund; also to provide for voting by proxy at the annual meetings. These topics for discussion will render the meeting an important and interesting one.

The following named candidates were admitted to membership, their application having undergone the usual close scrutiny by the Committee:

Dan'l Adams, C. E. Breckenridge, W. M. Cooper, J. M. Dayton, Chauncey Ives, C. W. Kelly, M. Lyon, F. G. Miller, J. Miller, F. W. Sander, W. F. Ackerman, N. Y. City; F. Koehler, Astoria, L. I., N. Y.; A. H. Rose, Auburn, N. Y.; G. A. Carpenter, F. A. Conant, F. H. French, Boston, Mass.; R. Gilmour, W. Medford, Mass.; Wm. P. Jones, Newburyport, Mass.; A. E. Rogers, Fitchburg, Mass.; Jas. W. West, Attleboro, Mass.; G. W. Ball, Hartford, Conn.; C. A. Mager, T. Pieper, Newark, N. J.; I. T. Abelseth, C. Reis, J. L. Shepherd, Phila., Pa.; G. Satterthwaite, Urbana, Ohio; B. C. Barnes, C. H. Bisson, Wm. Hirsch, S. Meyer, T. W. Phillips, F. Purdy, S. H. Upson, Chicago, Ill.; G. Weimer, Carrollton, Ill.; J. Braun, Two Rivers, Wis.; C. R. Hoffman, Waupaca, Wis.; P. J. Elinquist, Morris, Minn.; L. Strouse, McGregor, Iowa; H. H. Waldin, Burlington, Iowa; J. Van Brown, Hannibal, Mo.; E. R. Decker, St. Louis, Mo.; C. De Witt, Louisiana, Mo.; G. Beutelspacher, Newport, Ky.; J. W. Jones, Mt. Sterling, Ky.; G. M. Gill, G. J. Heinrich, W. I. Robinson, New Orleans, La.; G. V. Brady, Washington, Pa.; W. H. Davis, York, Pa.; S. J. Hayden, Pottsville, Pa.; D. A. Shiffert, Pottstown, Pa.; J. E. Tyler, H. Tyler, Richmond, Va.; F. A. Balthis, Charlottesville, Va.; E. F. Jakeman, Norfolk, Va.; W. H. Allardyce,

Galveston, Tex.; M. L. Freeman, Augusta, Ga.; Wm. Gibbs, Helena, Mon. T.; H. H. Henning, San Francisco, Cal.; P. A. Mix, J. H. Wehn, Staunton, Va.; C. B. Duckworth, Pawtucket, R. I.; G. W. Rutherford, Providence, R. I.; W. H. Cowles, Cincinnati, Ohio; L. M. Lea, Sandusky, Ohio.

Eight changes of beneficiaries were granted, 18 applications were laid on the table for investigation, 12 were rejected, and the above named 67 were admitted, making the present membership 2,950.

The following correspondence needs no further explanation than it carries with it in the reading, but is suggestive of the idea that the workings and the capabilities of the League are beginning to be appreciated as a factor of much good in our trades:

NEW YORK, Dec. 12th, 1883.

Mr. G. T. Woglom, President, The Jewelers' League.

DEAR SIR:—In accordance with a resolution passed at a meeting of the New York Jewelers' Club, held Dec. 11th, I take great pleasure in enclosing you a check for fifty dollars, as a donation from said Club to the League, to be known as a "help fund" and to be placed in the hands of your Executive Committee to be dispensed by them in the payment of assessments of worthy members who are unable to keep up their assessments.

Very Respectfully Yours,

J. W. SENIOR, Secretary.

NO. 61 NASSAU STREET, NEW YORK, Dec. 13th, 1883.

The New York Jewelers' Club, Mr. J. W. Senior, Secretary.

GENTLEMEN:—I hasten to acknowledge your favor of 12th inst., enclosing therewith your check for fifty dollars, a donation from the Jewelers' Club to the Jewelers' League, to be known as a "help fund," and to be dispensed by the Executive Committee in the payment of assessments of worthy members who are unable to keep up their assessments.

May I be permitted to express the opinion that the thought which actuated this gift is manly, is womanly. Manly, in that you stop and turn aside in the midst of a season when each of you has his head and hand pre-occupied by business to give to your troubled fellow a helping, encouraging hand. Womanly, in the tenderness of sentiment and intuitive prescience which looks so far into the future as to desire to help those who, dependent now upon a helpless man, in the event of his death without the benefits of the League, would then be entirely at the mercy of an unsympathizing world.

Your thoughtfulness is appreciated also as evincing a fraternal feeling between the two organizations, and thus it should always be.

I shall take pleasure in conveying to our Treasurer and to our Executive Committee your check and your kindly letter, and I now have pleasure in acknowledging and heartily thanking you for your generous gift.

Very Respectfully Yours,

GILBERT T. WOGLOM, President.

The efforts of President Woglom to acquire, for the permanent fund of the League, a portion of the unused balance of the Chicago Fire Fund has finally culminated in the favor of the League. The fund was subscribed on October 13th, 1871, and on October 13th, 1881, the President issued a circular inviting the co-operation of the members and soliciting the donation of their interests to the League by such subscribers as could see enough merit in the Jewelers' League to warrant them in doing so. The following named houses assigned their interest to the President:

J. A. Abry, (now C. L. Abry); H. F. Barrows; Albert Berger & Co.; Victor Bishop, (now Victor Bishop & Co.); A. Bernhard & Co.; Philip Bissinger; Bliss & Dean; Erhard Bissinger; Th. Bloch & Bros., (now Bloch Bros.); F. F. Brailard; Brainerd, Goddard & Steele, (now Brainerd & Steele); Estate of Paul A. Brez; John D. Brez; Brooklyn Watch Case Factory; Brown, Cook & Co., and Maas, Groeschel & Co., (now Cook, Groeschel & Co.); D. Bruhl, (now D. & M. Bruhl); Bruno & Son, (now C. Bruno & Son); Buckenham, Cole & Hall, (now E. G. Buckenham); T. B. Bynner & Co.; Samuel W. Chamberlain; H. A. & G. M. Church; William Cohen, (now Cohen & Co.); Colby & Johnson; Cooper, Fellows & Co.; Cox & Sedgwick; H. E.

Droz; E. C. Dunning & Co.; Estates of L. Durr & Bro.; Earle & Franklin; Samuel Eichberg; Eisenmann Bros.; A. Errico (now Errico Bros.); Joseph Fahys; Fellows & Co.; M. Fox & Co.; Charles Francke & Co. (now C. J. Francke); Freund, Goldsmith & Co., (now Max Freund & Co.); Julien Gallet; Giles, Wales & Co.; Henry Ginnel; Hayward & Briggs; Henle Bros.; Hessels & Ludeke; Wm. S. Hicks; Hodenpyl, Tunison & Shiebler, (now Hodenpyl, Tunison & Co.); John E. Hyde's Sons; Jacobs & Pratt; J. W. Johnson; L. & M. Kahn; Ketcham Bros. & Co., (now Ketcham & McDougall); R. Kipling & Son; F. Kroeber; Julius Levin; S. M. Lewis, (now S. M. Lewis & Co.); Lincoln, Tiffit & Co.; Albert Lorsch; Estate of George A. Mathewson; H. D. Merritt; J. B. Mathewson & Co.; Rachel Merrill, two-thirds of the interest of the firm of Merrill, Fitch & Allin; Miller Bros., J. M. Morrow; Nordmann Bros.; E. Obermeyer & Bro., (now H. Obermeyer); Palmer & Capron; Geo. W. Platt, (now Jas. W. Todd); J. W. Pooler & Co., (Courvoisier, Wilcox & Co.); Geo. W. Pratt & Co.; J. W. Richardson & Co.; Stephen Richardson & Co.; E. Ira Richards & Co.; John A. Riley & Co.; P. E. Robinson; Saltzmann & Co.; Robert Schell & Co.; J. E. Spencer & Co.; J. T. Scott & Co.; Silcocks & Cooley; Smith & Hedges, (now Wm. S. Hedges & Co., and Alfred H. Smith & Co.); Herman Sonntag; E. & D. H. Stites, (now E. Stites' Sons and D. H. Stites & Son); L. Strasburger & Co.; Geo. O. Street & Son; Sussfeld, Lorsch & Co., (now Sussfeld, Lorsch & Nordlinger); Vulcanite Jewelry Co.; A. Wallach & Co.; Wheeler, Parsons & Co., (now Wheeler, Parsons & Hayes); Whiting Mfg. Co.; D. H. Wickham and Wood & Hughes.

Upon the refusal of the Trustees, Enos Richardson and Henry Randel, to surrender the share to which the League had become thus entitled, suit was instituted before Judge Lawrence in the Supreme Court of the State of New York, and judgment has been rendered in favor of the President of the League. The sale of the bonds in which the trustees had invested the fund took place on December 19th, and the share to which the League is entitled will be in the possession of President Woglom before the 15th of the present month. The President has spent much thought and time upon this matter of infinite detail and tedious prosecution, and the Counsel of the League, George A. Miller, is as well entitled to unstinted praise for the vigor and thoroughness with which he went to the bottom of the case, developing a means at law by which title could be acquired, and in all the multitude of details necessary to its prosecution showing industry, and in forcing a victory his ability must be patent to all, especially in view of the fact that the Trustees of the fund had already consulted eminent counsel who had advised them that they could not be relieved of their trust except by an act of the State Legislature. The sum which will accrue to the League will be nearly if not quite \$5,000.

Advice to Watchmakers' Apprentices.

BY A MAN WHO HAS SPENT TWENTY YEARS AT THE BENCH.

A COMMON style of ornamentation to rings is beaded work, as shown enlarged at diagram *A*,* where *A* shows the round bosses in a continuous row, somewhat resembling a string of beads. These are produced by cutting with the graver in such a manner as to admit of the beading punch. We will suppose the row of beads or bosses shown at *A* extend across the shank of a ring; and now for the manner of producing them. First two lines are cut across as at *a a*; these are intersected by lines *b b*, which divides the space up into (say) six squares. These squares are the basis of the beads, and if the squares are quite small and the lines *a a* and *b b* close together the beading punch can be directly applied. The method of using the punch can be varied, *i. e.*, it can be struck with a hammer or used with a handle, giving it a rotary motion. To give the details: The beading punch is a short piece of steel wire of suitable size proportionate to the work to be done, and about $2\frac{1}{4}$ inches

long. It is shaped at the acting end into a concave as shown at *C* in vertical section; the point *d* is shaped as shown (magnified). The concave point at *d* can be either a flat hollow cone or a concave boss. These are shown in vertical section at diagram *D** where *c* represents a flattened cone and *f* a convex boss. The shape of the bead depends on the tool used, and of course the tools have to be made accordingly; if a conical bead is required the style of punch shown at *C* is needed; if a convex bead is wanted the form shown at *E* is used. In cutting the squares shown at *B*, the graver lines corresponding to *a a* and *b b* should be cut to facilitate the action of the beading punch, and a good idea of the proportion for a vertical section is shown at *F*. If the beads are quite large the squares formed by the graver lines can be again cut away as shown at diagram *B**. The cutting should be done with a flat bottom graver in the direction of the arrow *g*, making the central part *i* eight square. Much jewelry is now made with wire of a sort of knife edge form, a cross-section of which is shown at *G**; such wire can be drawn but for a small amount it can be more conveniently scraped. Such a scraping machine can be very simply made as shown at fig. 1, in which *H* represents a piece of brass or iron, about two inches long, by $\frac{1}{2}$ inch wide, and $\frac{1}{4}$ inch thick; into this is made a slot $\frac{3}{4}$ of an inch long by $\frac{1}{8}$ of an inch wide. This slot or mortise extends through the piece *H* as shown at the dotted lines *j j*, fig. 1. Into the mortise are

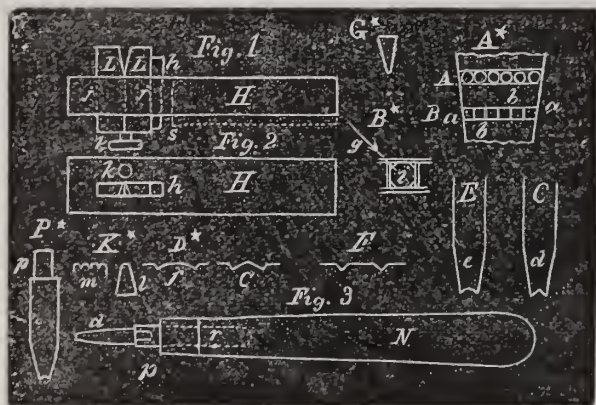

fitted two pieces of steel for scrapers shaped as shown at *L L*. Beside one at *n* is a wedge of brass or steel to fit or press the two pieces *L L* together. The upper ends of *L* are cut away so as to form a V-shaped notch which serves to shape the wire. The gold or silver wire to be made V-shaped can be flattened between the rolls, or a strip can be cut from a piece of flat sheet gold as wide as required, and the two ends grasped in a common saw frame to keep it taut, when it can be drawn between the two pieces *L L* which scrapes away each side. At *k* is shown a screw; this screw is gradually drawn back or down as the scraping proceeds, to prevent unequal cutting. This screw in fact serves as a guide to prevent the gold wire from entering the V-shaped slot too fast and unequally. The beading tools spoken of above are frequently used in conjunction with such edged wire. To do this the wire on the edge is filed or cut away until somewhat thickened at the edge as shown at diagram *K**, where *l* represents the wire cut across and the edge filed off, and *m* shows it filed into notches which are subsequently to be formed into beads. A good form of beading tool is shown at fig. 3; it consists of a nice ordinary tool handle, with a steel socket *o* fitted into it; this socket extends well up into the handle *N* as shown at the dotted line *r*. The beading points, consisting of a set of different sizes, are screwed into *o* as shown at *d*. An enlarged view of the beading points are shown at diagram *P**, *p* showing the screw which goes into *o*. This handle (*N*) can be used to produce the beading by gently tapping it with a hammer, or what is better, press it firmly on the bead and give it a turning motion. Of course it is to be understood that the squares cut by the graver as shown at *B*, diagram *A**, and the notches filed at *m*, diagram *K**, must be proportionate to the size of the beading tool. These tools can be turned up in a lathe, and if one has an American lathe it is very little work to make such a tool. When the tool shown in fig. 1 is used, it is put

into the bench vise with one end extending away from the jaws and laying horizontal. It should be put in the vise so that all embraced by the dotted line *s* should go into the vise. In my last article I referred to lapping certain surfaces: this is a beautiful mode of finish and entirely different from the process called (*lapping*) mentioned in several works on the jewelers' art, and applied to chains and lockets. The process I refer to is one now much used by diamond setters for producing a brilliant flat surface with absolute sharp angles and, all the flat surfaces dead flat and as brilliant as a mirror. To do this perfectly one would have to apprentice themselves to a practical workman and *take it the natural way*. Still enough can be told to help one into the way of doing such a job with credit. In such polishing, as in all other jobs of polishing, the great bane must be guarded against; and this is in the transitions from one part of the process to another, the greatest care should be taken to perfectly get rid of the grit of the material which does the grinding before attempting a polish, and in no instance is it more imperative than in the present case. We first have to produce a dead flat surface entirely devoid of any deep scratches—in fact, a perfect flat surface which only needs polishing to become brilliant. Suppose, for instance, we should use emery to grind our surface flat; no matter how fair it was it would not produce a polished surface, it would only leave a surface dead flat; we should have to apply some other material to get a polish. And now comes the rub; we cannot wash the surface free from small particles of emery actually embedded into the surface. Scratch brushing will help, but in this case the process will to some extent mar the angles. A composition lap of tin and lead, two parts of the former to one of the latter, makes the composition lap used for bright gold in chains, lockets, etc., but this, although holding the emery well (being a softer metal than the gold), still it leaves some scratches. The finest hone or whet slate leaves its scratches behind; consequently we must resort to other methods. A piece of Scotch stone ground flat on plate glass must be used to do the stoning; then with tin laps we must get the polish. Diamond with oil make a good paste to use, but it is only after repeated failures that one can expect to do perfect work, but patience and practice will accomplish it.

Problems in the Detached Lever Escapement.

BY DETENT.

THERE have been lengthy discussions among the craft in regard to balances, particularly compensation balances, as to relative size of balance and the number of vibrations which such balance should make to the second. Naturally one would imagine this question would soon settle itself, but it does not seem to; consequently we shall proceed to analyze it a little. No person will deny the proposition that for a pocket watch a certain size or strength of pivot is necessary for a certain weight of balance.

In conjunction with the consideration of this subject, I would call attention to the requirements of a balance—first it is a governing power, a mass of matter moving in alternate directions controlled by a balance spring. The greatest weight of the balance is of course in the rim, and it is the *peripheral* velocity which controls the action. To illustrate, suppose we have a balance half an inch in diameter; every time the balance makes a full revolution the rim or periphery of the balance passes through a little more than one and one-half inches of space; now, if the balance has one and one-fourth revolution of motion, and it beats one-fifth seconds, the rim of the balance must pass through nearly nine and three-eighths inches of space in every second. Now, the peripheral velocity is not a steady motion of $9\frac{3}{8}$ inches in a second, for the balance has to stop and start five times in the one second of time; consequently the maximum velocity is three or four times this rate. To carry this problem a little farther we will consider a balance $\frac{3}{4}$ of an inch in diameter, making

its motion of $1\frac{1}{4}$ revolutions, and we have a periphial motion of almost 3 inches (over $2\frac{7}{8}$ inches). Hence, if we give one watch four beats to the second, we have almost 12 inches of periphial velocity, an acceleration quite equal to giving the $\frac{1}{2}$ inch balance six vibrations to the second. If our balances are of the same weight we can certainly make our pivots of the same size. These facts would seem to indicate that the large balance with its high periphial velocity had the greatest advantages, for we have less pivot friction saving one vibration (a revolution and one-quarter), also saving the friction of one pallet action. And no doubt if the watch was left undisturbed it would be; but when subjected to the shake and jar of railway trains or even the motion of the human body, the quicker beat with smaller balances have given better results. One fact must be kept in mind, and that is, above a certain velocity of periphery the resistance of the air becomes a factor of great importance. I think most practical men will agree with me in saying that from 15 to 18 inches of periphial velocity to the second of time will give best results.

To resume the drawing of our roller action: We will assume for our model that we take a scape wheel diameter which is 5 inches for the length of one fork. On our drawing we use one-half this size and run the line diagonal for two reasons; first for economy of space, secondly, it is well to impress the idea firmly on the mind that it makes not the slightest difference whether a lever runs at right

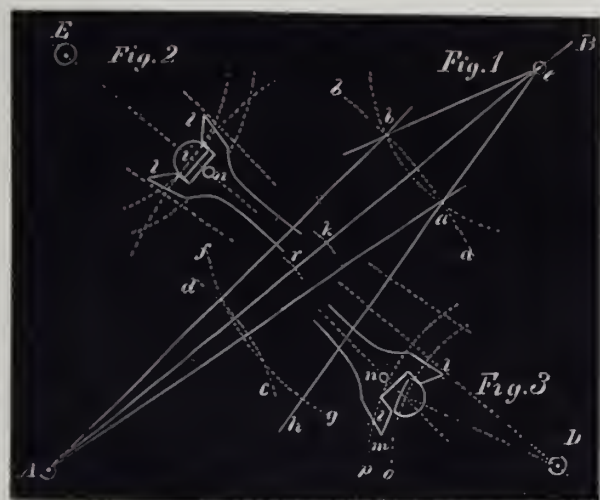

angles or not. We draw the line *A, B*, which is supposed to pass through the center of the pallet and balance staffs. It is supposed that we retain our first division of degrees made from a radius of $2\frac{1}{2}$ inches and shown in the cuts at half size, *i. e.*, $1\frac{1}{4}$ inches (see Oct., 1883, number). Because we have degrees on this scale we sweep the circle *c d*, and lay off 5 degrees on each side and draw the lines *A b* and *A a*, through the points established on the circle *c d*. These lines are 10 degrees apart, and the circle *a b* indicates the *pitch line* of the fork as engaging the jewel pin on the pallet staff, for the roller and fork action is only if correctly considered, a gear of one tooth which performs its functions and is then disengaged for a great portion of its circuit. We have now to establish the center of our pallet staff at such a point that 30 degrees of roller action will be equivalent to 10 degrees of fork action. We must now go about getting the position of our balance staff, and as was stated early in these papers we used no drawing instruments except dividers (compasses), straight edge and fine scratch point; we call to our assistance some geometry. It is well known to every person that the sum of the angles of any triangle equal two right angles or 180 degrees. The angle between the lines *A B* and *A a* must be 5 degrees (half of ten), and the angle contained between the lines *a e* and *e A* must be 15 degrees (half of 30). If we add these two angles together we have 20 degrees as the sum of these two angles, consequently the angle *A a e* is 180 less 20 or 160 degrees. If we now take $1\frac{1}{4}$ inches (our old measure) in our dividers, and set one leg of the dividers at *a* (or *b*) and sweep the circle *f*

g, we can on this circle establish our *A a e*. As the last named angle (*A a e*) contains 160 degrees, the complimentary angle must be 20 degrees; consequently we set off 20 degrees on the circle *g f*, and draw the line *n e*, and where this line crosses the line *A B*, is the center of the pallet staff. To make assurance more sure the process can be reversed, and *b* can be also used as a center, and where *a e* and *b e* cross is the center of the pallet staff. In laying out such work (as has already been urged), the greatest care must be used—your dividers must have perfect points, your straight edge must be perfectly true, and the tracing point very finely pointed. It is well to lay out the pallets and fork with roller action on a separate piece of brass or zinc, and then transfer the parts to the actual working pieces as you make them; by this means you keep a working record of the parts as they are made. In the accompanying cuts, fig. 1 is supposed to be a diagram of the action, and extends from the center of the pallet staff at *A* to *b*, the center of the balance staff. But in figs. 2 and 3 the ends are supposed to be reversed to show the action, as for instance in fig. 2 the center of the pallet is supposed to be at *D* and the balance staff at *E*. While in fig. 3 the ends are reversed the center of the pallet being at *E*, and the center of the balance staff at *D*. Fig. 2 shows the jewel pin *i* between the prongs of the fork *ll*. In regard to the proper relative size of a jewel pin about 4 degrees seem to give good results, and have all the necessary strength if the lever banks on pins, a system of banking now almost universally adopted. In speaking of 4 degrees I should have said measured on the arc of lever action. There is no rule for the form of the lever except to make it as light as possible consistent with strength. The ends of the fork should be shaped as shown in fig. 3. The ends of the prongs of the fork should be beveled at such an angle as to ensure the entrance of the jewel pin into the slot. In fig. 3 the dotted line *o* represents arc which the center of the jewel pin describes in its vibrations. We will suppose by some accident the guard pin *n* should rest against the table roller; if the end of the prong is shaped as shown at *m*, the jewel pin will pass the extreme angle at *m* and slide down the face at *l*, and enter the jewel notch correctly. But if the *draw* on the pallets is all right the guard pin will never touch the table except in extreme cases. In no case in examining such an escapement should the guard pin permit the fork to pass inward so as to allow the jewel pin to touch the angle at *m*. In the cut the lever is shown rather long, and it could to advantage be shortened to the circles *k* or *r*, that is, reduced in length $\frac{1}{4}$ or $\frac{1}{3}$. The same rules of drawing except the circle shown *a b* would be transferred to *k* or *r*.

Proceedings of the Horological Club.

A DISTINGUISHED BODY OF WATCH AND CLOCK MAKERS.

One hundred and fifteenth discussion.—Communicated by the Secretary.

[NOTICE.—Correspondents should write all letters intended for the Club separate from any other business matters, and headed "Secretary of the Horological Club." Direct the envelope to D. H. Hopkinson, Esq. Write only on one side of the paper, state the points briefly, mail as early as possible, as it must be received here not later than the eighth day of the month, in order to be discussed and reported in the CIRCULAR for the next month.

BENZINE FOR CLEANING WATCHES.

Secretary of Horological Club:

I noticed some time ago in THE CIRCULAR, benzine recommended by a watchmaker as very fine for cleaning watches. Having used several solutions in the past for this purpose with unsatisfactory results, excepting alcohol, I tried it, and was well pleased with it at first, until I had several watches (also clocks) returned, stopped, and found the oil gummy and hard at the pivots, although I was careful to peg out each hole well and brushed all parts after removing them from the liquid.

Is the fault probably in the quality of benzine? Or is it not advisable to use it at all? If well, where in New York can I procure the desired quality, and how would I designate it when ordering?

WATCH.

Mr. Horologer replied that only the purest of benzine should be used, as the ordinary qualities contain numerous hydrocarbons which do not evaporate readily, but remain on the metal soaked in them, and combine with the oil subsequently applied, making it thick and gummy as described by our correspondent. Pure benzine should evaporate completely. If the slightest smell can be detected on a piece of brass dipped in it, after exposure to the air of a room for one minute, it is entirely unfit for use on either watches or clocks. It is always well to *warm* all articles cleaned in benzine to insure its complete evaporation, and afterwards to thoroughly clean out the holes with soft peg wood as usual. Any first-class material house in New York will supply the right article. In ordering, call for *prepared benzine* for cleaning watches. If there is any doubt about the quality of the article you have, it will be safer to not use it at all, but employ pure alcohol in its place. As for the common benzine sold in drug stores, groceries, and similar places, it is not fit for any use in a watch repairer's line. And especially to be avoided is benzine put up in little bottles for removing grease, etc. Such are not only of cheap and impure benzine, but generally have some other ingredient mixed with it to make it "take hold." Benzine for watchmakers' uses can be bought with safety only from reputable and intelligent dealers in watch repairers' supplies. If the right article can be obtained with certainty, it will be very useful. Otherwise it is safer to have nothing to do with it.

OILING THE DETACHED LEVER ESCAPEMENT.

Secretary of Horological Club:

Will you please inform me about oiling the *escapement* of a *detached* lever watch? Should the roller pin jewel or the fork of the lever be oiled?

M. W. F.

Mr. Ruby Pin said that the fork of the lever should never be oiled. If it is properly shaped and polished, and of the proper size for the ruby pin which plays into it, no oil should be required, and if applied it would do more harm than good. As for oiling the lever pallets and escape wheel teeth, it is considered a mark of poor workmanship to oil them in a fine watch. But in cheap movements it is often found better to oil them than to let them run dry. Where it is a choice of evils, the workman may be allowed to do things which in other cases would be entirely out of place. But only a very little oil should be used in any case—just sufficient to lubricate the surfaces, but hardly enough to be perceptible with the eye-glass. When the escape wheel teeth run very close up under the lever fork above the pallets, particular care must be taken to avoid any surplus of oil, as it would soon gather dirt and clog the passing teeth.

SATIN FINISH ON SILVER—SOLDERING BRITANNIA.

Secretary of Horological Club:

I would like to be informed as to the best way of producing the "satin finish" upon small articles of silver. Also how to make the best working fluid for uniting common britannia metal and the solder which should be used with it. In answering these questions you will much oblige

JONES.

Mr. McFuzee said satin finish was produced by the use of the scratch brush. On the large scale the "sand-blast" is often employed. Small articles may have a fine dead white appearance given them by heating them to a "cherry redness" or dull red heat, and then allowing them to cool, when they are soaked in very dilute sulphuric acid solution, say about 5 parts of acid in 100 parts of water. Leave it there for a couple of hours. If the surface is not sufficiently uniform, rinse in hot water, dry, and again heat it and pickle as before. It should be quite cold before putting it into the acid. Rinse in perfectly clean hot water, and dry in clean boxwood sawdust.

For soldering britannia, use the usual chloride of zinc soldering fluid with a little salammiac in it. An easy-flowing solder can be made of tin, one part; bismuth, $\frac{1}{2}$ of one part; lead, one part; carefully melted together at a low heat.

EXCELSIOR'S WORKS WANTED.

Secretary of Horological Club:

I have "A Practical Treatise on Balance Springs" by Excelsior, published at the office of THE CIRCULAR, dated 1876, which is of great value to me. So much so, that if you have published any more of his works I must have them if possible. Please inform me about the matter. Please also send me a copy of "THE JEWELERS' CIRCULAR" with the terms. I have a copy Vol. IV., No. 5, "yearly subscription \$1;" I have reason to believe it different now.

F. F.

Mr. Uhrmacher thought our correspondent would have reason to regret that he had not become a subscriber to THE CIRCULAR from the number named by him. Excelsior had written a great deal since the publication of his "Treatise," but it had not yet been published in book form, and could only be obtained by purchasing the back numbers of THE CIRCULAR containing them, from 1876 to 1881. The general call for those back numbers had long ago exhausted the supply, and we can only answer Mr. F. the same way as the multitude of other inquirers, that no way remains but to advertise for some old subscriber who is willing to part with his file of the journal at some price or other.

Since the date mentioned THE CIRCULAR has been changed in form and enlarged from year to year, so that each number now makes a portly volume by itself, filled with practical information in all the branches of the watch, clock, jewelry, silver and plated wares, and other kindred trades, and business announcements from all the prominent manufacturers and jobbing houses, making it at once the recognized organ of those trades in this country, and the handsomest and best trade journal in our time anywhere. Mr. F. should by all means subscribe, and his life in the great Pacific will seem brighter with his monthly CIRCULAR to instruct and cheer him up.

THE GOING WATCH-SIGN AGAIN.

Secretary of Horological Club:

Looking over the last number of the Proceedings of the Horological Club, I was pleased to see that you mentioned my new street timepiece, representing a large open face stem winder. How the clock moves, I can only say that the driving 8-day American clock hangs in the middle of my store, right above my bench, and moves the outside clock through a thin wooden rod. How the clock is constructed inside I must keep for the present to myself, but as there is no falling of the hands on one side and the contrary on the other, therefore the clock is always correct. The hands are under the glass. About the wood-cut I have only a small one of it like the one enclosed, for the daily papers. I will try to send you a better one this week yet if possible.

ADOLPH STAIB.

Mr. Clerkenwell regretted that Mr. Staib had not felt free to describe how the outside clock was moved by the one within the store, but hoped he would favor us with full particulars on that point at another time.

ABOUT PATENTS AND CAVEATS.

Secretary of Horological Club:

I would like to ask a few questions, and come to you for information. 1st. Can an article be safely manufactured and sold under a "caveat?" In such case how should it be stamped. 2d. Do the *small tools* brought out by the trade and patented, pay as a general thing in case they are thoroughly practical and adapted to the use intended? 3d. How can I secure a caveat without paying a patent attorney about twice as much as I would have to pay for the caveat? Could I send direct to the commissioners of patents, and would the papers get through in the course of an ordinary lifetime? S.

Mr. Clerkenwell said that a caveat gave no protection to a manufacturer. It is a description of an invention filed by the inventor in the patent office, and gives him the right to be notified by the office if anyone else files an application for a patent for the same thing, or nearly like it. In that case he will have to make application for patent within three months. The rules of the patent office require: "192. The caveat must comprise a specification, oath, and, when the nature of the case admits of it, a drawing, and, like the application, must be limited to a single invention or improvement."

"193. The same particularity of description is not required in a caveat as in an application for patent; but the caveat must set forth

the object of the invention and the distinguishing characteristics thereof, and it should be sufficiently precise to enable the office to judge whether there is a probable interference when a subsequent application is filed. If upon examination a caveat is found defective in this respect, amendment will be required." The caveator will not be entitled to notice without compliance with all other rules relating thereto.

"195. When practicable, the caveat should be accompanied by full and accurate drawings, separate from the specification, well executed on tracing muslin or paper that may be folded." The drawings must be of same character as for application for patent.

"196. If at any time within one year after the filing or renewal of a caveat another person shall file an application with which such caveat would in any manner interfere, and if, within the year, the application shall be found patentable, then such application will be suspended, and notice thereof will be sent to the person filing the caveat, who, if he shall file a complete application within the prescribed time, will be entitled to an interference with the previous application, for the purpose of proving priority of invention, and obtaining the patent if he be adjudged the prior inventor. The caveator, if he would avail himself of his caveat, must file his application within three months from the expiration of the time regularly required for the transmission to him of the notice deposited in the Post Office at Washington; and the day when the time for filing expires will be mentioned in the notice or indorsed thereon."

"197. The caveator will not be entitled to notice of any application pending at the time of filing his caveat, nor of any application filed after the expiration of one year from the date of the filing or renewal thereof. The caveat may be renewed by the payment of a second caveat fee of ten dollars, and it will continue in force for one year from the date of the payment of such second fee. Subsequent renewals may be made with like effect."

"198. A caveat confers no rights and affords no protection except as to notice of an interfering application filed during its life, giving the caveator the opportunity of proving priority of invention if he so desires. It may be used as evidence in contests, as provided in Rule 150 (6)."

It will be seen that there is nothing to do but to *file* the papers. They then continue in force for one year. An applicant may, of course, file his own papers, and dispense with the services of an attorney, just as he may defend his own lawsuit in any court in the land, provided he is sufficiently well informed to do so. If not, he had better employ a professional to prepare his papers properly, and attend to the business for him. Any small tool which is thoroughly practical and adapted for general use, ought to pay if properly placed before the trade. It may be manufactured and sold, but at the risk of the inventor. He has no exclusive right until it is *patented*. He may stamp the articles "caveat filed," but as that would be equivalent to saying "Not yet patented nor applied for," it would be better not to stamp it at all. If the invention is completed, our advice would be not to file a caveat, but a regular application for patent, and so secure it as soon as possible.

Echoes from the Bench.

REMINISCENCES—EXPERIENCES—SUGGESTIONS—WANTS, ETC.

To the Editor of the Jewelers' Circular:

As a corollary to my attempted description of a model bench, allow me to say that even such a handy arrangement as this affords is of small avail unless its advantages are lived up to. Before it was my privilege to see such an one, and when working as a jour., whenever a new shop was reached, the following was about the first effusions—after an introduction: Now, gents, I wish you to know that there is not a tool in my possession but what every one of you are heartily welcome to the use of—but one condition must be

insisted on—well what is that? That such tool or tools must be put back to their place whenever you get through with their use, not even waiting until you can do so conveniently, but *immediately*, in case that some other one may need them—so that they may be found invariably where they belong, a vowel among the vowels, thus avoiding a mixture with the consonants, to the end that every second of time may be utilized. If ye cannot agree to this, then do not touch them, for you will not be welcome—and more—shall certainly have to read the riot act to you. That's fair! That's fair! was the usual response. A few stern examples soon cured the neglectful, and aroused them enough to see an advantage therefrom and follow it.

You, sir, and your readers have, no doubt, often seen men who did work quickly and still have their tools all littered over the bench, but the very same workmen would astonish themselves should they give the other system a fair trial. It *seems* such a waste of time, but it is only a *seeming* hindrance—the time of all times I realize it the most is when tools accumulate on the board, that I am losing time, for it cannot be denied that the tendency to accumulate is natural. About a year ago, when at work on a very fine watch worth some \$500, concentrated attention being called for, my right hand went mechanically twice to one drawer and thrice to another for tools and *replaced* them ere I was aware of what had transpired, and in a momentary soliloquy said mentally, that's handy!

If we are to be controlled by a habit, will not all say it were better to be a good one. Some workmen are naturally slow—memory reverts to one who was always reliable—would not adopt a botch plan on any account, but his best gait was but "two miles in the three hours," and woe to any one who sought to urge him faster, while another could in a push double or even treble his usual pace, slighting nothing—and not be nervous, nor did we need to tell him what is true of some; that he was handy to have around in a slack time, for if the watch did not need repairing when it came in, it *would* before it went out, if he had the handling of them!

Now every shop has its times of hurry, when the impatience of customers tries workmen. At such a time a well-ordered kit tells amazingly! Nor is this the only causistry traceable here. Can any one say truthfully that the training here alluded to and recommended shall stop at the tools; will not this habit so possess one's mind that every item connected therewith shall be influenced by it? Shall not the plans which were considered as *models* when younger pass, like the spelling-book of the school-boy merely as a step-ladder up to the higher grades of thought and of action?

And lest it be forgotten, let me mention this to young men: wherever I worked, this purpose was invariably kept before me, I *shall* have more wages next year—but—but—this purpose also accompanied it, like two parallel rails: I shall make my services of such value *now*, the present *now*, that he or they cannot afford to say *no* when the demand is made. If ever refused, I do not remember the time. When through fair agitation, such as may come through such happy mediums as these columns and others of other publishers, in the interest of our craft, the time comes that employers will see it to be to their interest as well as to their workmen, they will pay them by piece-work, this, with rare exceptions, usually sifts the botches—the sheep from the goats. Who ever saw a botch in search of work that refused to accept a job because it was not piece-work—where all his "stoppers" should be cured of their tricks *out of his own time!*

When a painter, or rather an artist, who understands human nature, tries to sell a picture, he finds that his customer, who is not altogether lacking in taste, is not up to his own standard of culture, he calls attention to each point, and patiently waits for the appreciation to overtake the buyer ere he expects to make a profitable sale. Are we not often placed in a similar position in respect to watch repairing—and in selling too? How unreasonable then it is to see some of our craft become impatient at a customer's apparent stupidity, in a trade so full of intricacies, and at whose mercy every customer lies—being so fully in his power. The art of taking in

work advantageously is the best part of one's duty sometimes—having succeeded a workman once whose situation never commanded over \$15 or \$20 a week, while the employer declared he had never cleared over \$10 or \$12 on any of them, and when asked how I wanted to work? Piece-work—and that only. I don't understand *how*, said he. Well, the cost of materials is to be counted out first, then equal halves, and all stoppers cured out of my own time. When could you come? To-morrow morning. Come! come! In a few months the trade developed so that we had each \$40 a week—and seldom used artificial light either. Death claimed him, or should never have left such a cheerful and just man as he was. And every item was fair schedule prices, as charged across the river in New York. To mention this to the craft may appear as egotistical, were it not that the back-ground of the picture has yet to come, and that is this: but a *very short time* before this had worked for a New York firm still in existence, and very greenly trusted that a fair equable wage would be paid me—being on probation. A week or two's sickness and my place was filled—they crawling out with the excuse that they knew not that my tools were still there, and settled on the basis of six dollars a week! !

Another illustration will show the high sense of fair play some have. At my left sat a man over fifty on piece-work, on the right one of the best I ever saw work—an Englishman at that—the wages he was working for, coming out incidentally, so surprised me that I offered to get him just *three* times that sum to begin with, if he would say the word that he would go to an inland city but some twelve hours distant. This eye-opener developed higher and yet higher wages, until he absolutely refused to work longer but on an equal footing with the rest of the men, who were all on piece-work. And to show also how one may be wrongly estimated—all the other hands thought him the slowest workman there! And yet all came intuitively to him for advice when a difficult problem was to be solved—but because his poise and self-command was so great they set him down as slow, why, it were difficult to say, unless this, the entire absence of fuss. Meantime, full of good humor, would tell me, with a face as grave as an owl, when bothered with a stopper, that "It goes fast, and slow, and occasionally stops!" Well, at the end of two weeks, although not fully supplied with piece-work, he got about seventy-eight dollars! Should have liked to have been there to see how their eyes bilged who held one in such low esteem—while his head continually preceded his hands.

Physiologists maintain that the *laws* of ill-health are as beautiful as those of good health, only they are more distasteful to follow. The confinement to twelve hours of daily work coming on so suddenly, when an apprentice, bore its natural fruit, viz., sick head-ache, which very nearly averaged two entire days, weekly, and the necessity of leaving a business I loved, because of this, was just all but forced upon me; however, stick-to-it-ive grit overcame all. And as it is such a common trouble in every business of a sedentary nature, notably in ours, if it might benefit some who read this if similarly afflicted—should consider *that* apology enough to those who are blest with exemption therefrom. For none will deny the importance of being in prime *condition* for bench-work. Had more of physiology been taught at the schools my parents and 'prentice boss attended, what a painful legacy I might have missed. What apology can expiate the effects of over-dosing with nauseous drugs? calomel, etc.—a mere battle to remove effects—without any relation to the cause, for every effect must have a cause. The food fed me being about the best that could have been selected to develop the billiousness which overtook me, and although physicians without number of all schools have been consulted, their prescriptions are all or nearly all relating more to the effects, rather than reaching back, as they ought to, to their cause.

And so I said: Mr. Mind, just stand out yonder, and look introspectively upon this machine, and now by dint of watching it—and the effect certain kinds of food has upon this same machine—the conditions are changed. A quack will give the same cure to all.

To avoid being suspected as such, will forbear stating any one thing—except this: my better half thinks it very poetical, you know! to be able to feed her jeweler on gems—not the pure carbon—but Graham-flour gems, three times a day the year round, and wonders that she cannot get him cloyed on them! As well try to sicken the watchmaker of using *good* watch oil, because Mr. Porpoise perfumes it—the irrigation is wisely proportioned. Result: sick headache and I are strangers now.

Nervous people have done a great deal for the world, and some of the best workmen existing are nervous men, but the best, the *very best* combination, is when we find the nervous man a man of nerve, "a distinction with a difference" emphatically. And when one finds he has been gifted with such a composition, has he any just right to abuse it? If the organ be out of tune can the player charm his audience? Is not that wonderfully intricate system worth some deference? Shall we ignore its rights and call ourselves intelligent because of its mysteries? And is not the nervous system related to the mind of its owner in some measure as the organ to the player?

The nerveless man takes the misfortunes of life out in fretting. The man of nerve refuses to yield to such a weakness; his every action says: "Let the rope go with the bucket," and pushes on to redeem the past by new acquirements.

When a hotel guest, deprived of sleep by the continual and excited walking of some one in the next room at two or three o'clock in the morning, called to ascertain the cause—Oh! good gracious, I have \$800 to meet at 10 o'clock, and know not where a dollar of it is to come from! You consummate fool! go to bed and *let the other fellow* do the walking, was the sage advice! The creditor of that man should have praised the soundness of his philosophy, because it would enable him to economize his strength to sustain or reclaim his credit.

Without attempting an essay on moral or mental philosophy, allow the liberty of calling attention to instances coming under my own observation with the hope that if none such exist now, I shall be forgiven for the obtrusion, and also encourage some hitherto silent man to post us with some of his experiences for comparison, either to profitably warn or to emulate.

And now, if columns like these are at our disposal, shall the *useful* or the merely popular phase preponderate? Was it not Demosthenes who rebuked his fellow citizens because they applauded him for simply doing his duty as he called it? Was his manhood not ahead of theirs, when by such rebuke he proved to them that the roots of his tree called for more nutrition than the soil or atmosphere which mere popularity could supply?

"That word *duty*," said Wellington, "has cost me more than all the other words in the dictionary."

The press have recently taken notice of the deterioration of the manufacture of fine cutlery, notably in razors, in some town or towns in England, and as it has been the drunken habits of the workmen that are the causes—may this note of warning be received profitably as from one who is friendly to our noble craft—to the end that no slavery to any appetite shall conquer the young manhood of our fine mechanics.

The one on my left was a well read Scotchman, and having a retentive memory could support his part of the discussion on almost any subject. He treated with contempt any shortage of less than \$35 or \$40 a week. He passed for a good workman with his employers, as none of them were practical workmen, and had very few "stoppers," but he could neither file nor polish flat to save his life, but merely gave his best attention to the essentials.

His plan was to repair six or eight watches the same day and then take them home in boxes, dangling in his pockets, clean them and put together at home, working to do so as late as 2 o'clock in the morning. Now, what was the result? An exhausted nervous system, which in that condition could furnish no "governor," and a spree was the next thing in order. If he worked one week would spree the next, or if two, then two were spent in dissipation, and so

on until *delirium tremens* ended the matter with the poor fellow. Now, had he realized this fact that everyone, however strong, has his limit of vitality—he would have been content with less wages, and more timely rest might have wholly averted, or at least greatly modified, what may have been the fruit of a hereditary legacy which he was not wholly responsible for. As many as fifteen or twenty very likely young men have I seen wholly incapacitated from learning our trade because of inability to restrain appetite—either stimulants or narcotics. None can love coffee better than I do, but the stimulation it affords is got at too great an expense thereafter to risk its use; weak tea, say the uncolored Japan, is far better, as it saves the waste of tissue the former does not.

A neighboring lady friend has several times had me join the hunt for her son, a confirmed inebriate, to reclaim him to their home from the saloons near midnight. While I never doubted the sincerity of certain professions she made, she would doubtless be sadly shocked were it hinted that something she had done had the remotest relation towards the procuring such a result. She was a confirmed coffee "toper" to the amount of several cups of the strongest at every meal, and such CANNOT transmit a healthy, but a shattered nervous organization to their offspring. "To the third and fourth generation" has a terrible significance if unheeded now! It cannot be denied that there are some constitutions on which its effects are not so visible, but the great bulk of our craft have as fine nervous systems as that of almost any other to be named, and the tendency is rather to heighten this susceptibility than to diminish it as years roll on. When the Babcock extinguisher was first shown here, they planted some twelve empty barrels with open ends facing a cold, keen wind, filling them with shavings, kerosene, etc. After firing up and extinguishing those barrels a number of times they were not very sightly! Could we get a glimpse of our own nervous system after a similar treatment of stimulant and sedative or narcotic, would we not be surprised at the comparative resemblance?

Last jour. I worked with, said you are the first man I ever worked with, where I did not have to shun the "dirty circle" as I neared him, or looked for a lost wheel or pinion. A responsible jeweler of Sixth avenue told me that his watchmaker after having dropped his eye-glass twice, stuck it on with such force the third time that his eye was black and blue, accompanying the act with expletives too strong for printer's ink to report. Query, was the coffee too strong for the tobacco? Or had it not had time to operate? "Mind conquers matter" could hardly apply here. After many useless appeals to a young man to reform when in the last year of his apprenticeship, I was greatly surprised one day to have him say, "I have been a great fool, but if you will overlook the past and forgive me for all the ingratitude I have shown, I will pledge myself to a sincere and manly reform, and will heed with deepest interest your counsels." It is needless to say that I heartily assented to this and labored for such an end—but his hands shook like a palsied old man, and he not twenty-one; he had to quit the business as a *botch*. It was not rum with him—only coffee, tobacco and late hours, and these combinations are all sufficient. A friendly rival of our craft, after playfully puffing his smoke in my face, said, "Why there is not so much harm as you describe;" replying, "I have no business to interfere with your habits further than mere persuasion, as every one may do as he pleases; but should your wife ask me for a drink of water, and I were rude enough to offer that in which I had just washed my hands you would say that I insulted her—and you would be right too! And still she at her option could refuse it—but she has no such option with you, for you just force the impure air from your filthy mouth down her throat, and laugh when she squirms! Now, who perpetrates the greatest insult?" He had the good sense to smile a silent assent. Had the GREAT MECHANIC who made us intended its use, would HE have left such a delicate piece of machinery without a convenient flue?

A truant memory prevents my locating what was but recently dished up by the press. An instance where such surprise was

awakened that the enquiry was made of the Prince, or whatever title adhered to him, how the members of his court were usually so healthy. It passes for a pagan court, too—he pleasantly replied that he paid his physicians to keep them *well*—they were *fined* for allowing one to get sick—and something else, now forgot, in proportion when one died! The impression created on me was that we were not so far ahead as we claim—unless it were false, or concocted by some one well in advance as his ideal of the future for man's necessities—a model of treatment that society is not ripe for.

This may seem very irrelevant matter to those who have always been gifted with health—but having suffered so much from well-meant ignorance—consider it but a friendly act to warn the young—to start them in the search for causes, and have *them* removed; effects will take care of themselves. Occasions may arise when even good physicians are limited by the same conditions as the contractor who must *flush the sewers*, the location being on a dead level will not permit it to be done by gravitation. As in our own craft occasions may arise when nothing but the universal lathe can make the necessary clearance; but it is botch work to pursue it, as good workmen will strain every nerve to have the staffs correctly uprighted knowing that the horizontals will come all right.

Trust to nature more and artifice less; when weary do not stimulate, but *take rest*; plan ahead for it, take it in some way. If fortunate enough to enjoy, or what is better, have the ability to practice music, try its soothing effects; the key which is most congenial to you at such a time will denote the condition of your nervous system, like a tell-tale clock. For you well know what dreary work it is to have to drag this weary body to do fine work with a yawn in the supremacy or lurking about the horizon.

The refreshing which nature furnishes when her wise laws are obeyed, when in the morning the heart goes bounding to its work, and idea after idea comes tripping along so timely, that the tough job left unfinished last night is half overcome by fresh plans ere you reach it—every organ in the system moving so gracefully that you are not aware of the existence of anyone—all being such a harmonious unit. Then—then bring your hateful narcotics, hug your chains—study the anomaly or paradox of a caged bird singing, "For freemen never shall be slaves," and re-assert as do the bird fanciers that the smaller the cage the more music is ground out of its poor occupant; would such logic affect the heaven-ward soaring lark?

Some blast their tobacco through a hideous pipe, others through a cigar, I prefer it through a pen. The editors will back you to a man; they are clean fellows, and will excuse this familiarity; just look at these columns and dare to imagine one of them defiled like the commoners!

It would not take a great stretch of the imagination, if, when a detachment of this dirty tuts, I mean this tobacco brigade, were to meet another brigade who used ipecac, sulphur, garlic, etc., and discharged the results of such combustion in *their* faces. All serene, would hardly fit there! Lead along to a hotel front, look at the pavement where they have loitered, what are the traits? Why a poulterer has bivouaced his herd here when on a migratory tour. Oh, no, you are mistaken; this is but the trade mark of *our own brigade*. What an honor! To which column do you cling, young man? Is true liberty a mere myth with you? Or if you are determined to hug your chains, do not say you have not had your attention called to it, although you number as seventeen to three, and still more do not call yourself a full freeman but rather classify yourself intelligently, as they probably rated the slaves, according to the fractions of white blood; state whether you are octoroon. If, when working ten hours, you are under some other influence than your own—if five hours—call it a half breed, half slave and half free or whatever the proportion you actually sustain. One good mechanic I know, of another craft, on his sixth and last attempt to leave off the use of tobacco, declared that he looked for over fifteen minutes to find his hammer, and found it on his bench *where it belonged!* Could our young men have heard the self-censure he uttered, and the heart-felt

regret he gave vent to upon his resumption of the slavery, they would pause, investigate, and resolve to be *free!* In fact, and in short, the only rival I should dread to compete with would be that man who could show such a practical instance of will power that he can conquer himself. It would create a somewhat similar impression on others, as that made on the British officer invited to dinner, who on finding that the patriotism of the American officer who invited him was so genuine, that he could not only dine but *live* on sweet potatoes, left off fighting against such sincerity of manhood, resigned his commission and went home.

All of the above, however, is but suggestive entreaty. And if it gives offense, am perfectly willing to be forgiven. And whether free or not, but especially if free, be sure to learn first of all to do your work *well*—so well, that if the maker of the watch were present he would sanction your handiwork. And secondly, after you learn the *how*, resolve that none shall surpass you for speed, carefully avoiding the very appearance of fuss. The fussy chap may beat you at a day's work, but that is not what tells. What *tells*, is the return of the same customers year by year with the aggregate of their influence added thereto—few so insignificant but what they exert some influence on a certain circle, and the impression created by work well done is not and cannot be counted merely and strictly in relation to the pay it brings, but bears profitably on the sale of goods—and very likely on watches—that portion of a carefully selected stock the least subject to fluctuations and consequent loss.

If an accident overtake you, be sure to keep cool; if you break a pivot and it be a very difficult job to do—do with your nerves what you would with your muscles if you had a twelve or fifteen feet ditch to jump—just collect your coolest strength, concentrate your nerve power, and you must succeed. In fact, the force of this habit of concentration so often practiced, if not well on your guard, may unfit the mind to put in practice what a *successful* employer usually has, viz., the ability to concentrate at pleasure without doing so at the expense of another equally or perhaps more important faculty—that of generalization. This is probably why some who are excellent workmen are but poor salesmen or merchants. Shall relate an instance of coolness—just occurs to me. When about taking leave of a friend with whom we had spent the evening, and while taking a drink of water he halted a moment to tell us something, when down went the beautifully decorated cup to the floor, water and all, out of his hand. Without moving a muscle of his face, he just set down one foot firmly on the pieces and *held it there* while he finished his story amid a roar of laughter from over a dozen of us! When he finished—confounded thing! should a trifle interrupt one in the full possession of his faculties?—he then heartily united with us. How much better than a useless fret.

And now, lest some young man grows faint-hearted when he reads so much advice from such a variety of sources, do not harbor the thought that all or even any of these writers have had all smooth sailing, and that no untoward accident is ever theirs. Some time lately I had to put a pivot into the lower staff of a fine Swiss lever watch, perhaps about 17 ligs, a Patek, Phillipe & Co., beautifully made; to avoid the risk of using an untried and new drill, I made one out of a small file which I knew to be good—made it in my lathe with the oilstone to avoid extracting its temper, as it had to be small, in fact the smallest I ever used. The staff had two rollers, the lower one of which I undertook to remove with a brass-lined plyers as usual. Well, it came off, but it was not of the “come off” kind legitimately like the coin plasters advertised. It had a confounded ragged edge left! but there was no use of praying, even internally, that light might be shed on the brain of the benighted workman who would make two rollers and one staff all out of the same piece! Let the prayers of the craft ascend in his behalf, that such a benighted cranium may be flooded with light so penetrating that he shall either reform or have said cranium converted into electricity—while time lasts—or ever thereafter be fed on Waterbury watches!

The upper roller containing a beautifully made ruby pin of triangular shape was just the thing of all things I dreaded to have further trouble with, and so the resolution rose equal to the occasion, and as “necessity is the mother of invention,” had recourse to a stratagem which may inure to the benefit of some one else. I took out the T-rest out of its socket (being an American lathe), and put in a German silver tube which happened to fit it, then placed a drill in the lathe, first having marked where to drill in the table, the top of which was left up a little higher than the lathe center; the rest was then securely tightened and the drill entered, when by slackening the binding screw of lathe head in which the drill was running, this allowed the head to be pushed along to make the feed come from the left hand, to get the hole correctly through the tube, by leaving the tube the same height as when drilled, all around where the hole entered, and by cutting down the right hand side half a little way, a rest was formed for the graver to finish the new pivot, and also to finish the staff where the “come off” occurred, preparatory to putting on a new roller that would come off when required. It will be readily implied that after the drill was removed the upper end of staff was held by a wire-split chuck, while the lower end ran in the hole drilled through the tube, being thus enabled to avoid all tendency to chattering, or springing, or breaking. It has also been found to be very handy to enlengthen a conical pivot when too short for the jewel hole. Again, after an hour's vain search for a scape wheel and pinion, the boy found fragments enough, to convince us of the folly of losing more time, in the sole of a customer's shoe recently in the store. Silent redeem the time energy took the place of the customary spree—so often practiced.

Such was the dread entertained of being dubbed a slow workman, when an apprentice would occasionally take a spurt, which might have been systematically sustained, had our sulky boss known enough to encourage us with a cheerful hint of appreciation, which never came but in the most indirect way.

One day the temptation occurred to have some fun and open the dummy's mouth. Having prepared every tool before he went to tea—and he certainly had a complete kit—I made a pair of barrels to an English clock from the rough castings, and had them ready for turning in just twenty-five minutes. Was wicked enough to provoke his ire to the highest pitch by committing what in his eye was an unpardonable sin, viz.: to loiter a few moments on the street *in his sight*. When he returned to the store—we had both left—he let more noise than music out of the door, the way he slammed it!

When well ready, the cause of the storm returned, when lo! what a transformation; he was like to eat me up with kindness. It was a lasting victory, although he most carefully avoided any direct allusion to that which tickled him. And owned freely to another that it would have taken him over four hours to repeat the same, being a very heavy man and lame at that, but as fine a mechanic as I have ever met.

At the risk of being called vain, I refer to this chiefly to call the attention of those having charge of the young as overseers of work, etc. I believe that a frank, generous acknowledgement discreetly given will inspire the young, frank, trusting nature, and do more to develop proficiency in their trade or calling than all the snarling begrudged compliments ever furnished since the craft began!

If the young man inclines to inflation, how easy to furnish him with a few tough jobs in succession, enough to reduce the swelling! Have always found it in the ratio of ten to one in favor of discriminating, not fulsome, praise, rather than censure. “Tom, here's another extra dollar because you kept your temper so well when that exasperating customer so sorely tried you!” Won't Tom do still better next time, and don't you make hasty Will envious to rate as high as Tom in his employer's esteem? Try this, ye that are skeptical.

Must close without being able to reach the wants, etc., as per heading. Shall try first spare moment to detail a watch-rack as a rival of the bench, and also try to pump some of your friendly contributors.

Very respectfully,
Rochester, N. Y.

J. H.

French Jewelry.

NOVEMBER and December are the great months for the Parisian jewelers and trinket makers. In view of the demand for New Year's gifts, they bring out their new models and dress their windows in the most tempting manner. As far as my observations go, and they go all over Paris, fashion in jewelry continues to be materialistic rather than decorative. Jewels, both in metal and in precious stones, are not made with a view to beauty of design; richness or chaste simplicity, elegance of line or delicacy of ornament are no longer aimed at by the designers of the moment. The great thing is to invent something amusing. It will be remembered that a year or two ago talismans or *porte bonheurs* in the form of a little golden pig had immense success; then the golden pig was ousted from favor by a humpbacked manikin, and the humpbacked manikin was threatened in his turn by a mushroom. The fashionable talisman now seems to be the owl and the owl's head. A beautiful brooch is made of an owl of diamond dust perched in a gold crescent moon, and framed in a wreath of flowers in diamonds or brilliants. Jeweled owls' heads are used as hat trimmings, as well as tufts of real owls' heads, which are also stuck on the front of the little surah or velvet or plush muff elaborately frilled with Chantilly lace. The new mantle agrafe consists of two medallions united by a curb chain; each medallion is a lizard of oxidized silver coiled round upon itself. The new hair or hat pin is a long gold skewer with, at one end, also in gold, a miniature Japanese open bamboo *écran* or hand screen, into the interstices of which are worked flower and other designs, relieved with enamel.

Two other new ideas are black silver jewelry—not to be confounded with oxidized silver—and mineral crystal jewelry. This latter is simply a thin spat of gold set irregularly with precious stones, as if a bit of molten gold had been dropped on the table and then strewn over with emeralds and rubies and diamonds. The spat is then mounted as brooch, ear rings, or what not. In another form of the mineral crystals the metal has the actual form of crystals, and amid the irregular mass of octohedric, hexagonal, rhomboidal, and other shapes of precious stones are set as above described. The fancy of the designers is generally divided between the animal and vegetable kingdoms, and the accessories of the table, the stable, the garden, and the carpenter's shop. You find brooches, ear droppers, pins, clasps, in the form of saws, hammers, blow pipes, watering-pots and spades. Whole scenes are reproduced in gold and precious stones. On a golden gable roof two swallows in diamonds are shown building their nest; the head of a terrier, in brilliants, emerges through the crevice of a golden board in pursuit of a silver rat; a couple of kittens, in diamonds and emeralds, playing with a big pearl, make a brooch; a clown in full costume, drawn and colored with gold and stones, or harlequin, pantaloons, and columbine, or clown's head alone, executed in the most brilliant stones, forms likewise a brooch. Diamond horses galloping through a horseshoe and diamond poodles leaping through hoops are also in high favor for buckles and brooches; so, too, are Skye terriers' heads executed in diamonds, and camels and elephants and all kinds of birds, and even toads. The skill with which the brilliants and colored stones are employed in accentuating the modeling of these objects is marvelous. Your toad, for instance, will be a simple mass of brilliants, and the mounting quite invisible. Besides these fantastic baubles, splendid work is done by the great jewelers now in making flowers and branches of foliage in diamonds, roses, clematises, a branch of diamond holly with coral berries and the like, all of exquisite perfection in modeling.

For deep mourning unpolished onyx jewelry is chosen. The long bar lace pins have several ball or cube pendants and have an oval or square surface. For second mourning there are beautiful pins, rings and bracelets of black polished onyx set with pearls. Many of the bar pins have fine pendants, either balls or cubes, the one on either end being smaller than those in the center. Seed pearls set in clover leaf, lily of the valley, tiny star and buttercup designs are shown on

some, others have a single row of pearls reaching nearly the length of the bar. Rings for the ears match the pins, or else are the screw rings which set on the ear and are held in place by a little flat gold wheel that fastens it at the back. In some of the ball rings is a single pearl with crown setting. Flat surfaced rings have stars or tiny flower designs in seed pearls. Watch chains or guards are of fine black silk braid or blocks, cubes or balls of faceted onyx fastened together with gold links, they are much stronger fastened in this way than with silk; the fastenings are arranged so as to show very little of the gold. Guards are also made of the unpolished onyx. Bracelets of faceted onyx are ornamented at the ends with caps of gold set with pearls.

The newest mourning note paper has a deep border of black, which is a perfect imitation of English crape, and is called crape mourning paper. Octavo size is generally preferred to the commercial, and may be had either ruled or plain. The French paper is thought to be the finest, but that of English and American manufacture is also shown. The width of border varies from a fine cord edge not more than 32-100ths of an inch to three-fourths of an inch. Note and invitation cards have borders from the very narrow to the extreme wide.

Black satin fans with appliqued flowers of crape are the newest; when spread these measure twenty-four inches from tip to tip; the sticks are of polished ebony or black pearl. Others without the appliqued figures have a fine feather edge.

NOT VERY long ago the French government discovered that they had been for years systematically swindled by certain watchmakers at Geneva. Until the discovery in question led to a change of system all articles of jewelry entering France from Switzerland were stamped at the frontier, and, when re-exported, a drawback equal to the duty was returned to the exporter. The stamp, or hall mark, was taken as proof that the duty had been duly paid, and beyond a declaration as to the ownership no formalities were required. This system suggested an ingenious and easily practised plan for getting the better of the French Custom House. Gold chains, brooches, watches and similar articles were sent openly over the frontier, stamped, and the duty paid. This was the first stage of the business. They were then taken to another custom house on the border, declared for export, and the drawback secured. The next procedure was to smuggle them back into France and get the drawback a second time (of course at another custom house), and so the ball was kept rolling—for nothing is easier than to smuggle jewelry—and it went on rolling until a jeweler at Geneva who had failed and been, as he thought, badly treated by his confederates, revealed his plot out of revenge. Several houses of alleged respectability in Geneva were implicated in the business, and those of them who had branches in France were heavily fined. The latest dodge is making bogus coin for circulation in Egypt and the East. A short time ago the Egyptian government prosecuted the counterfeiters, but were unable to get redress. The Geneva tribunals, before which the matter was brought, decided that as there exists no treaty between Switzerland and Egypt for the reciprocal punishment of fabricators of false money in their respective territories, the prosecution had no case. And even if this difficulty had not arisen, the defendants would probably have been acquitted all the same. In the East coins are used both as money and as ornaments. The coins fabricated in Geneva were called ornaments, and strung together in the shape of bangles and bracelets. The parties concerned might easily contend—did, in fact, contend—that it was not within their knowledge that the articles they were making were coins at all, or intended to be used as money. It is no part of a Switzer's duty to understand Arabic or be conversant with the coinage of the East; and when a Geneva jeweler receives an order, the only inquiry he is called upon to make is an inquiry touching the solvency of his customer.

Practical Treatise on the Adjustment of a Four-Jewel Cylinder Watch.

[First-Prize Essay by HERMANN HORMANN.]

Continued from page 363.

120. It frequently happens that when the center wheel holes have been bushed rather tightly, the center wheel, after mounting the center staff, will cramp in its pivot holes. The following is the reason: the sides of the pivot is in such cases very thin; the center staff ends above rather conically, and, when inserted into the canon it presses it a little apart without bursting it. This fault is corrected by fastening the staff in a hand vise and grinding or filing it somewhat thinner at the place where it endangers the pivot.

If the upper hand was bushed outside the center in order to place the center wheel straight, the cap will sometimes sit to one side, whereby the dirt plate rubs at the cap, and which, besides, prevents the key from fitting correctly upon the square. If the screw holes in the cap are rather small, they may be filed a little elongated; in a contrary case one or two holes are to be bushed in order to place the cap or dust plate concentric to the center staff.

121. The hand square must be thus that it can be turned with gentle friction, so that the watch do not stand when the hands are moved backwards. Should the staff move much too easy, it is to be replaced by a new one. It is permitted only in exceptional cases, either in a rapid adjustment or else with very inferior watches, to increase the friction of the staff by rolling it between two files or upon the filing wood so as to raise a certain kind of burr upon it. Should too much have been raised, fasten the square of the arbor in a hand vise, and polish it carefully to suit upon the filing wood.

When the staff moves to satisfaction, take the canon, place it upon the former, and with a hole punch drive it up to the pivot of the center wheel.

122. The canon pinion must sit firm upon the staff and not rub below upon the plate. If it moves here too scant, and if the turning out of the plate is not advisable, then the pinion must be rounded off from below, for which purpose the screw head polishing tool is employed; the canon is fastened in one of its tongs, revolving exactly true, and ground rounding with an oil stone, after which it is polished with a composition file and rouge or diamantine. After it has been cleaned and the burr removed from the leaves, it is mounted again in its place upon the center staff, and the depthing into the minute wheel is examined first by driving it with the barrel.



A defect occurs quite frequently that the canon pinion, in consequence of too long and too far projecting a center pinion pivot, stands too high, whereby the minute wheel can very easily pass underneath the canon. For correcting this fault, the center pinion pivot must correspondingly be turned shorter. (Article 31.)

123. The remarks previously made about the depthings of the running works (see article 99 to 109), is also applied here. The minute work is more grateful in so far as it sooner suffers a little incorrectness, for instance, the fourth wheel depthing. If the one or the other depthing is too deep, round the offending wheel upon the rounding machine until correct in size. It very frequently occurs with inferior watches that the minute wheel pinion runs untrue or is a little too large, which necessitates its being turned down, and to reproduce a rounding. It is more advisable, however, with such pinions, which, in consequence of their insufficient temper, have been beaten out of shape by riveting the wheel, or which cannot be riveted correctly, because their riveting was too short or turned too thin, or, finally, which has some other important defect to replace it together with the minute wheel.

If, however, the depthings are too shallow, one is forced to stretch either the minute and hour wheels, or to move the minute wheel pin a

little closer to the canon. It is solidly executed by opening the hole for the minute wheel pin a little by broaching, filing it cornered inside so that the bushing to be inserted cannot turn during the cutting of the thread, and it is then riveted nicely with a close bushing. After it has been turned again upon the universal tool, both the depthings are regulated with the depthing tool, by having placed the minute work upon turning arbors from which the pulleys have, for this purpose, been taken down.

124. If the repairer does not desire to bush the hole, file the screw thread in the plate somewhat elongated with a fine round file, set a half-round punch upon the edge of the hole upon the side opposite to the canon pinion, and with a few light taps with the hammer drive the hole a little over in this manner. It would be well at present to take a minute wheel pin with a stronger thread which is cut into the hole, after which a nice groove is turned around the latter upon the universal tool, by which the indentations caused by the punch are completely removed.

125. If only one of the two depthings is too shallow, or if the depthing is good otherwise, only that one or the other wheel runs a little untrue, it is permissible with the minute work to stretch it. For this purpose the wheel to be stretched is laid upon a flat anvil, and the taps with the flat of the hammer are directed less upon the toothed circumference of the wheel, but they are given more upon the full face of the wheel, whereby, if sufficiently thick, it is disfigured less, after which it is ground again. The wheel is next rounded upon the machine, and passed through with a suitable Ingold fraise.

126. The scraping of the minute wheel upon the barrel found in many watches and often occasioning their standing still, because the wheel teeth fasten in the notches of the cover, is remedied by rounding off the lower face of the minute wheel especially toward the teeth, a job which can be performed in the turning tool.

The same is true of the hour wheel, which frequently catches together with the tooth points of the star; this error may in many cases require the mounting of a smaller star.

127. It may also happen that by misconstructed watches the hour or minute wheel may scrape on the third wheel, because the centers of motion are placed too closely together, and the bottom in the plate is turned through. This can often be improved by raising somewhat the third wheel.

128. The hour wheel must not move so high that it can leave its depthing, or so low as to rub upon the third wheel. If the hour wheel moves too high in consequence of unduly high leaves of the minute pinion, the latter are made a little lower by grinding away from below if the canon is very long; in the contrary case it is turned off from above; else, with very thick hour wheels, a groove is turned on the lower side, in the middle, around the hole, a little larger than the diameter of the minute canon pinion.

129. A bushing is to be made in the hour canon when it shakes upon the minute canon, or if the wheel moves too low so that it is exposed to scraping, and in consequence of which the bushing is to project a little below; and, finally, if the minute canon runs very untrue, whereby the depthing of the hour wheel is altered.

In these cases the minute canon is turned round upon the turning tool, after which it is ground and polished again. The hour canon is then broached from below, a fairly cylindrical bushing turned in, and firmly beaten in, which is then broached with a very tapering broach, fitting to the minute canon, and turned true as well as above with regard to height and length. It is to be observed that after this work the hour hand is again to be fitted on, because the canon widens by the beating in of the bushing.

130. The hour as well as the minute wheel (the latter with its pinion) must have sufficient shake under the dial. In doubtful cases, therefore, it is well to again mount the dial, applying a little rouge to the minute pinion, while the shake of the hour canon can be felt. If there is too little shake, both parts are turned a little lower upon the turning tool, and the minute wheel pin is shortened thus that it projects a trifle beyond the pinion; or else a little of the enamel is taken off from the back of the dial with emery.

(To be Continued.)

Obituary.

CHARLES WOOD.

We are pained to record the death of Charles Wood, of the firm of Wood & Hughes, the well-known silverware manufacturers of this city under circumstances of a most painful and melancholy character. The deceased has for the past 27 years been the senior member of the house which bears his name, and was highly esteemed by all who knew him. For the last four months he was unable to attend to business in consequence of malarial and gastric derangement from which he had long suffered, and while in a fit of temporary aberration of mind induced by his ailments threw himself from the window of his residence, receiving injuries which terminated fatally. Mr. Wood leaves a wife and two children to whom the sympathy of a large circle of friends are extended.

drummers sell nickel watches and clocks as cheap to me as I can buy them for in Chicago, and will sell to any store keeper or blacksmith the same way; but such things don't hurt me. All I have to say is, try to do everything to please and get the confidence of your customers, and if any of them want a fine watch or chain they will call on you. Every store in my town keep watches and clocks for sale, and I assure you that I sell more of them than they do. About three years ago a drummer selling silverware come to my town selling common single plate stuff, representing it to be 3 and 4 plates; to-day I can buy all that he sold for one quarter of what it cost them. So you see they will in time get sick of handling jewelry, silverware and clocks. I have taken advantage of THE CIRCULAR'S suggestion and have replenished my store with fancy goods, such as pictures, frames, musical instruments, etc., and am very well satisfied. Wishing THE JEWELERS' CIRCULAR success, I am as ever, yours, etc.,

GUS. BROWN.

Views of Correspondents.

This department of THE CIRCULAR is open for communications relating to the jewelry trade, but the editor does not hold himself responsible for the sentiments expressed by contributors. We invite correspondence, but require that it shall be free from all personalities, and the writer's integrity guaranteed by the disclosure of his true name to the editor. Anonymous communications will not be noticed.

BAYOU SARA, LA., Nov., 1883.

To the Editor of the Jewelers' Circular:

I have noticed of late that a great deal is said in regard to auctions, traveling salesmen and salesmen for hardware trade interfering with the country jewelers. I would like to give my experience on this subject, and inform the trade how it is carried on down here in the cotton and cane regions. A few weeks ago I happened in the city of New Orleans. I walked up the principal street, within three blocks, and a stone's throw from one another I saw three jewelry auctions. I took the trouble to stop to see and listen. In the show cases they had some very fine watches and jewelry; the gold watches were marked, so as the audience could see the retail price, ranging from \$50 to \$300; the auctioneer would open the case, put his hand in the tray where the watches were, and pull out a gold plated (duplex) watch. Now that watch being among those fine ones, makes the bidder think it must be a fine gold watch although the auctioneer does not say so. The (capper) offers \$25 to start it. Some country fool bids as high as \$50 or \$60, and if the capper sees that he is anxious it is no telling where he will stop. I have stood by and have seen sleeve buttons that cost 60 cents a dozen pairs bring as high as \$1.50; fire gilt chains that cost \$6.50 to \$7.50 per dozen were sold for 18 karat rolled plate. Therefore, I say if this selection package business was stopped there would not be so many auctions, for this reason; some jewelry houses allow as much as fifteen days to return the goods, and in the meantime these auctions sell all they can and return all unsold. I hope that THE JEWELERS' CIRCULAR will succeed in stopping such business as selection packages. I think it is a good step, and I for one heartily indorse it, and trust that the wholesalers will take some steps *and aid the good cause of THE JEWELERS' CIRCULAR.*

In regard to traveling men for the hardware and cutlery trade, I would say this much: It cannot be stopped, and we must do the best we can. I have very little complaint to make about them. I will here state a little case: Some time ago a friend of mine asked me to order him a castor; the next day one of the hardware men happened in town, showed him his catalogue which contained silverware illustrations 40 per cent. discount on all of the prices; he told me not to order the castor as he could get one for \$5, which was cheaper than I or any other retail jeweler could sell it at. The castor will be shipped in with some other goods, so you see I could not say that I would let him have it at the same price. I would lose money by such a transaction. But I am still happy. Why, dry goods

The Jewelers' Security Alliance.

THE JEWELERS' Security Alliance, organized some months ago, for the protection of retail jewelers against the depredations of the criminal class and rendering them efficient detective service in case of safe burglaries at a time when they are less able to afford the expense of a thief chase, is constantly adding to its strength by the admission of new members.

The following applicants have been admitted to membership during the past month:

Wm. S. Taylor, Utica, N. Y.; Edwin P. Chapman, Oneonta, N. Y.; G. W. Fairchild, E. W. Button, Bridgeport, Conn.; T. V. Dickinson, Buffalo, N. Y.; Thos. B. Fanton, Danbury, Conn.; Geo. H. Ford, G. H. G. Durant, Geo. L. Struter, New Haven, Conn.; Ernest Schall, Deming Gundlach, D. H. Buell, Thos. Steele & Sons, David Mayer, Hartford, Conn.; D. C. Barrows, J. R. Robertson, Leander Freeman, Willemantic, Conn.; Andrew Hobron & Son, Hustace & Anderson, New London, Conn.; Geo. E. Shaw & Co., Putnam, Conn.; Milton Kohler, Hagerstown, Md.; Bingham & Wack, Indianapolis, Ind.; W. P. Jones, Safford & Lunt, Joseph Moulton, Newburyport, Mass.; Joseph H. Holister, Greenfield, Mass.; F. A. Knowlton, Worcester, Mass.; J. A. Robbins, Springfield, Mass.; Alvah Skinner & Son, John R. Knight, Wm. B. Parazina, Chapman Seabury, Harrigan & Freeman, C. F. Morrill & Co., Geo. H. Richards & Co., T. S. Davis, Boston, Mass.; C. W. Haskins, New Bedford, Mass.; L. B. Coe, Springfield, Mass.; H. F. Barrows & Co., North Attleboro, Mass.; Harry Raynor, Bacon Bros., Lowell, Mass.; S. C. Newhall, Lynn, Mass.; H. G. Hudson, Anusbury, Mass.; Trefsthon & Moore, Clarke & Brown, Manchester, N. H.; E. W. Folsom, Great Falls, N. H.; W. P. Hanna, Sharon, Pa.; J. C. Hanna & Son, New Castle, Pa.; C. H. Lamson, Portland, Me.; C. P. Eldred, Honesdale, Pa.; L. Nurcerean, Scranton, Pa.; Edward Bailey, Hamrick & Son, Philadelphia, Pa.; E. O. Zadek & Co., Mobile, Ala.; Giles, Bro. & Co., Chicago, Ill.; Chas. Hartdegen, J. Kendall Smith, Newark, N. J.; Isaac B. Kopper, Titusville, Pa.; C. N. Gunther, Geo. C. Schafuss, P. W. Taylor, Brooklyn, N. Y.; Whiting Manufacturing Co., New York; Sayton & Hendrick, St. Joseph, Mo.; Frank A. Robbins, Pittsfield, Mass.; Henry Rawlands, Albany, N. Y.; Geo. E. Sherwood, Waterloo, N. Y.; Hutchinson & Cobb, Hornellsville, N. Y.; Seely & Son, Ogdensburg, N. Y.; F. A. Ackerman, Canojoharie, N. Y.; Belknap & Crist, Newburg, N. Y.; Chas. M. Hoffman, White River Junction, Vt.; S. M. White, North Adams, Mass.; Taber & Chapman, A. Judson Rand, J. W. Meacham, Holyoke, Mass.; S. W. Fellows, Lawrence, Mass.; D. Greenleaf & Co., Jacksonville, Fla.; C. S. Sherwood, Portsmouth, Va.; F. L. Davis & Bro., Nashville, Tenn.; W. H. Evans, Red Oak Junction, Iowa; H. A. Heath & Co., Newport, R. I.; B. H. Brower, Toledo, O.; James Allan & Co., Charleston, S. C.; Edgar A. Brown, St. Paul, Minn.; J. L. Schweizer, Selma, Ala.; Addison Bros., Chelsea, Mass.

All communications should be addressed to H. W. Hiller, Box 3277, New York Post Office, or 12 John street, N. Y.

Workshop Notes.

STRATENA CEMENT.—The cement so frequently sold by this name on the street is the old, well-known American cement. It is so adhesive that it glues jewels. It is made by dissolving isinglass in alcohol with gum ammoniac. When correctly prepared it is perfectly transparent.

TO ENGRAVE ON COPPER. NEW METHOD.—Coat the copper with any of the silvering solutions frequently described in *THE CIRCULAR*, cover it with colored varnish, then draw the lines with a sharp point in the manner of using a diamond for stone engraving, and etch them in with perchloride of iron.

CLEANING SILVERWARE.—Professor Davenport reports in the *Pharmacist* that hyposulphate of soda is the simplest and most effective cleansing material for silverware. It operates quickly, is cheap, and has not yet been proposed for the purpose. A rag or a brush moistened with the saturated solution of the salt cleanses, without the use of cleaning powder, strongly oxidized silver surfaces within a few seconds.

TO HARDEN CASE SPRINGS.—In order to harden case and other pressure springs it is well to first heat them, then rub them over with soap, heat them to a cherry red (not a white heat because the steel would burn), dip them quickly in petroleum, anneal light blue, in place of oil rub them over with tallow, let it smoke off and cool on the annealing sheet. The tempering and smoking off is best performed outside the workshop, since a bad smell is created thereby.

COATING STEEL AND OTHER METALS.—According to P. Villiers the article to be coated is first washed with a feeble acid, next with water, and dried at 80°. It is then dipped into a fluid alloy of 90 parts tin, 9 parts lead, and 1 part silver, cooled in cold water and polished. In order to make the surface still more capable of resistance against acids, it is coated with an amalgam of 60 parts mercury, 39 parts tin, and 1 part silver, and may finally be gold or silver plated.

PRESERVING STEEL FROM RUST.—Mr. F. Grace Calvert some years ago drew attention to the fact that steel after immersion in caustic soda or caustic potash is preserved from liability to rust. This apparently valuable information does not seem to have been acted upon by chronometer makers and others. Balance springs of chronometers have been occasionally coated with collodion, but the thickness and rapid decay of this film interferes with the time-keeping qualities of the chronometer.

TO CLEAN BRASS.—On the authority of our European exchanges, we recommend the process in use in our United States arsenals to be the best in the world. And how could it be otherwise? A mixture is made of 1 part common nitric acid, and one-half part sulphuric acid in a stone jar, having also ready a pail of fresh water and a box of sawdust. The articles to be treated are dipped into the water, and finally rubbed with sawdust. This immediately changes them to a brilliant color. If the brass has become greasy, it is first dipped in a strong solution of potash and soda in warm water. This cuts the grease so that the acid has free power to act.

POLISHING WHEEL.—The best method is to grind the wheel well upon a cork, and to pay strict attention to remove all the burr from the limbs. Then polish with a zinc file which has been moistened with crocus and alcohol. After the wheel has been polished with it, take a sword file and finish polishing with it. Before using, the sword file is to be sharpened and rubbed with a little wax, after which the file is wiped off upon a piece of cloth, so that only a film of wax remains upon it. A brass wheel may also be polished in the following manner, viz.: by grinding it with slate stone and oil, and polishing with diamantine upon boxwood, with a few short strokes. For sharpening the sword file emery paper is much employed, after which the file is in gradation sharpened upon decreasing by finer emery.

CLEANING POWDER FOR SHOW WINDOWS.—A good cleaning powder which leaves no dirt in the joints, etc., is prepared by moistening calcined magnesia with pure benzine so that a mass is formed sufficiently moist to let a drop appear when pressed. The mixture is to be preserved in glass bottles with ground stoppers, in order to retain the easily volatile benzine. A little of the mixture, when to be used, is placed upon a lump of cotton and applied to the glass plate. The mixture may also be used for cleaning mirrors.

BLACK LACQUER FOR IRON.—A good black iron lacquer is composed of 10 parts by weight of copal or amber lacquer (the darkest, cheapest kinds), 1 part by weight of brown English dryer, and 3 parts by weight of best printer's ink. This lacquer, like any other, may be diluted with oil of turpentine, gives a handsome luster and covers well, and best adheres to articles when they are baked in a drying furnace; or asphalt is dissolved in turpentine; this dries quickly; if a little well-boiled linseed oil is added it is more durable but dries more slowly.

FLUID GLUE.—A fluid glue is prepared by dissolving in a water bath a certain quantity of glue with the same quantity of strong vinegar, one fourth alcohol and a little piece of alum. Owing to the vinegar, this glue also retains its fluidity in a cold condition. It is very handy for a number of small jobs for which an adhesive agent of great power is not necessary, since it is always ready for use and lasts for an indefinite time. Manufacturers of imitation pearls use it in large quantities; it is also useful for glueing mother-of-pearl, horn, etc., to wood or metal.

TO COLOR BRASS BLACK.—To very handsomely color brass black mix 180 grams carbonate of copper, 400 grams aqua ammoniac and 400 grams water. The cleansed brass articles are to be dipped into this mixture, frequently withdrawn to inspect them, and rinsed in water and dried in sawdust, and the process is repeated twice; the articles are then feebly rubbed in with a little linseed oil; the color will then be that of black ebony. The old process with silver is somewhat dearer, and another one of dipping, hot, into nitrate of copper is ruinous to delicately soldered articles, wherefore the first mentioned method is preferable.

TO PREVENT TARNISH OF SILVERWARE.—Table ware and other articles of silver, as well as plated, almost invariably tarnish, especially if stove coal are burned either in the house or neighborhood, because the sulphur contained in the former blacken the silver. This may be completely protected by coating it with a fine brush with collodion, which has previously been diluted pretty strongly with alcohol. This coating dries at once and forms a very thin, transparent and invisible protection which shields the silver completely, and, if necessary, may be washed off with hot water. This process is much employed in English silver stores.

PHOSPHOR BRONZE WIRE.—The experiments of Nystrom and Rothen show that phosphor bronze wires have an electric conductivity about one-fifth as great as that of copper, for one and a half times as great as that of iron. Bede has found that one kilometer (1093.633 yards) of phosphor bronze wire, two millimeters (0.0787 inch) in diameter, has a resistance of 28 ohms, while an iron wire of the same dimensions has a resistance of 40 ohms. A wire well hardened at the drawing plate has a tensile strength of 120 kilograms (264.55 pounds) per square millimeter, and stretches about one per cent. before breaking. A wire which is properly annealed stretches about 60 per cent., but the tensile strength is only about 40 kilograms per square millimeter. The rupture of a telegraphic or telephonic wire may cause accident to people or houses. Bede has shown that when a wire of phosphor bronze breaks, its elasticity brings the fragments toward the neighboring support before they have time to do any injury. In Brussels, a large number of telephonic lines have been supplied with phosphor bronze wire of $\frac{3}{16}$ millimeter (0.0315 inch) in diameter. In Ghent, nearly the whole telephonic net-work is laid with the same wire. This small diameter can be employed because the resistance of the wire to oxidation secures its durability.—*Ingen. Conseil.*

Trade Gossip.

There is quite a boom in wedding rings.

There was a great falling off in the holiday business.

Rubies are as popular as ever and quite as expensive.

Jewels are much in favor for the hair at evening parties and balls.

Bates & Bacon have perfected their filled case and will have a full line ready early this season.

The Jewelers' Club has decided to give a dinner at the Astor House early in the present month.

Amber-colored tortoise-shell has come into prominence in England for articles of personal adornment.

All the Executive Mansion clocks at Washington have been changed to correspond with the new time.

In the recent fire at Dubois, Pa., C. M. Powers' jewelry store and stock was damaged to the extent of \$1,500.

S. C. Jackson has issued his usual New Year's greeting to the trade in the form of a very useful and practical calendar.

A Maiden Lane house of prominence fell a victim to the bogus check scheme recently. Fortunately the amount was not large.

F. E. Eberhard, the young man who attempted to defraud several Bridgeport, Conn., jewelers, has been sent to jail for six months.

Louis Neresheimer, of E. Aug. Neresheimer & Co., and F. L. Martin, of Samuel Eichberg, sailed for Europe in the *Fulda*, Dec. 26th.

The firm of Hopper & Valentine has been dissolved by mutual consent, Mr. Valentine retiring. The firm will hereafter be Hopper & Wilson.

The most fashionable ornaments for the hair are crescents, stars, sprays and combs of Rhine crystals, often so fine as to be mistaken for diamonds.

Messrs. Stern & Stern meet with much sympathy in the recent bereavement they have sustained in the loss of their father, who died December 11th.

Some of the newest salad bowls are made of pale peacock blue and watercress green frosted glass, with scalloped brims, and have ladles of hammered silver.

A peacock made of carved brass, with a tail of real and very beautiful peacock feathers arranged in an upright position, is one of the latest devices for a screen.

The firm of Katon & Bauman, of St. Louis, has been dissolved. H. H. Katon has established himself in the watch material and optical business in this city.

Oxidized silver ornaments for household decorative purposes come in new and novel designs from Vienna, the models originating in the National Art Schools of that city.

J. L. Clark, traveler for C. G. Alford & Co., was robbed of a tray of chains while showing his stock to D. C. Callender & Co., of Waterbury, Conn. The thief made his escape.

Bacon & Co.'s jewelry store at Boston was recently entered by burglars and robbed of a quantity of watches, diamonds, jewelry and other goods. They were not members of the Alliance.

D. E. Oppenheimer, of the firm of Falkenau, Oppenheimer & Co., recently sailed for Europe in the *Alaska*, and will visit the diamond marts of the old world in search of goods for the spring trade.

Neapolitan jewelry, consisting of brooches, lace pins, rings, and bangles of silver filigree in all sorts of fanciful forms, such as tambourines, serpents, mandolines, violins and guitars are popular.

Harris, Van Nortwick & Co., of Providence, has dissolved, the firm will hereafter be known as Harris & Southwick, and will give their exclusive attention to the manufacture of fine gold jewelry and rings.

Shoplifters who put their spoils of jewelry in their mouths should never do business when they have colds. A woman of this class coughed up four valuable rings in a Philadelphia jewelry store and was caught.

J. M. Rutherford, the well-known jewelry auctioneer, has just conducted three very successful sales, one for W. Haight & Co., of Auburn, R. J. Manning, of Binghampton, and G. H. Van Winkle, of Hornellsville.

A jeweler living in Newark claims to have seen the enormous sea-serpent off the coast of New Jersey. Considering the potent efficacy of bottled lightning in that locality, it is a wonder more huge snakes are not seen.

Howard & Scherrieble and Hamilton & Hamilton, Jr., have leased offices on the second floor of No. 176 Broadway, which they have fitted up elegantly in cherry, all the furnishing and fittings being in exquisite taste.

Two young men recently entered the store of Barthman & Straats and asked to be shown some diamond rings. After their departure the clerk found they had taken a \$130 ring, leaving a paste diamond ring in its place.

F. W. Hall, a well-known traveler for Reed, Daily & Bettman, of Minneapolis, is one of the most popular travelers in the western country. He is a Green Mountain boy who went west to grow up with the country.

Gen. George H. Ford, of New Haven, has received an order for a watch from King Kalakaua, of the Sandwich Islands. It is to be a massive gold chronograph of elaborate design with dial showing three standards of time.

An almost closed ostrich feather fan in old silver, with a tiny thermometer on the uppermost stick, comes among Vienna novelties. It is a mural ornament, and has a cord and tassels also in old silver, with which to hang it up.

The Northwestern Watch Case Company has increased its facilities for producing the Climax case, and now offers special inducements to purchasers. This is a live, energetic company, and is conducted on sound business principles.

S. Rothchild, a jeweler doing business in Memphis, who recently failed four days after buying \$1,000 worth of goods from Hess & Schliesser, of this city, has been arrested for alleged fraud and subsequently indicted by the Grand Jury.

The imitations of iron and brass repoussé work in the forms of plaques of plaster, with a French composition back, are of such merit this year as to look like the real metal plaques of former seasons, while the designs are new and highly artistic.

F. Jenkel and his two sons, well-known jewelers of Dubuque, Iowa, were recently drowned by the upsetting of a boat. The party had been out hunting and were on the river returning home when a squall struck and swamped the boat, drowning the occupants.

In France every black poodle who respects itself wears a gold bracelet on each of his fore paws; the dog-collars are made of the most varied designs, with elegantly chased *grelots* or bells, or with pendants of medals or droppers, exactly like ladies' necklaces.

"Show me a thermometer—one of your best." Salesman: "This, ma'am, is one of our finest—Venetian glass and the best quicksilver." Mrs. Shoddy: "Silver. That would be nice for the kitching, but I want one for my booder. Haven't you one with quick gold?"

The Excelsior Sign Company, of Chicago, is out with several novelties, emblematic of the watch, clock and jewelry trade. The work of this company is regarded as standard in the trade. Their signs being not only novel and appropriate, but well made and lasting.

At a meeting of the New York Jewelers' Club held Dec. 11th, a resolution was passed donating fifty dollars from the Club to the Jewelers' League to be used to pay the indebtedness of members who, through misfortune, are unable to keep up their assessments.

Pierre, Dakota, is a growing place. It is scarcely three years old but gives employment to five watchmakers, three of whom carry stock valued at from \$3,000 to \$5,000 each. Trade in that section is reported to be in good condition and dealers are doing a fair business.

The novelties in black, silver and brass which come from Vienna this season embrace a wide range of objects from paper weights, writing and smoking sets to plaques and ash, card, and waste paper receivers, not to speak of match boxes and other small pieces in fanciful forms.

A gentleman in Brussels claims to have contrived a perpetual clock. It was started in the latter city about one year ago, and up to a recent date is said to have been running perfectly. An up draught is obtained in a tube or shaft by exposing it to the sun. This draught turns a fan, which winds up the weight of the clock until it reaches the top, when it actuates a brake that stops the fan, but leaves it free to start again after the weight has gone down a little, and thus the power is stored for keeping the clock in motion.

The prettiest designs for the heads of those dressy little lace pins that are used to decorate and fasten jabots and frills of lace are tiny leaves of the rose in various colors, on one side of which is a diamond dew drop or a diminutive abalone shell, with a pearl or diamond dropped on its iridescent tip.

Anthony Comstock has been making a raid on some of the tea stores where jewelry is alleged to be placed in certain of the packages sold. It is claimed that this proceeding is a violation of the law prohibiting lotteries. Mr. Comstock has made several arrests, but the men were paroled for examination.

One of the latest novelties is the literary bracelet. It is made of twelve tiny books, silver or gold, attached to each other by a double chain. Each little book bears the enameled name of a favorite poet or novelist. There are also musical bracelets of the same model, only they of course have the names of operas or composers.

Rogers Brothers some time ago obtained an injunction against C. Rogers & Brothers, prohibiting them from using the name of C. Rogers & Brothers on silverplated ware. An appeal was taken to the Superior Court, where the decision was made in favor of the defendants. The plaintiffs appealed to the Supreme Court.

R. Henrich has just introduced an ingenious device for changing the setting in seal or initial rings, by simply relieving the setting by a set screw under the box; the end pan slides out with the stone and any other charm can be substituted. A glance at Mr. Henrich's advertisement will convey an idea of the importance of this novelty.

Some weeks since \$10,000 worth of diamonds and jewelry were stolen from the safe of Mr. Darling, jeweler at Sonoco, Ont. Soon after the robbery two notorious cracksmen were arrested on suspicion, but one of them was acquitted. Counsel for the two men returned nearly all the diamonds and claimed the reward of \$2,000 which had been offered for the recovery of the goods stolen. It has been ascertained that when one of the thieves saw the other acquitted he threatened to turn informer.

Among the stationery novelties of the season may be mentioned menu cards, single and double, in various tints, emblematically designed; and larger menus on ivory Bristol board, tinted and white, with an elegant border in sepia, and gilt edges in a bevel. These last are made so as to stand on the table. There is also a condolence card, pale amber in tint, to fold, on which are emblematical designs, with suitable words in sepia, relieved by bands of silver, altogether with a very tender and pretty effect.

On Wednesday evening, Dec. 5th, Miss Beatrice Madeline Howard, daughter of S. P. Howard, of the firm of Howard & Mohle, was married to Mr. Ferdinand Van der Perren. The wedding occurred at the residence of the bride's parents, No. 433 East 58th street, Mr. Howard's friends in the trade being present. The bridegroom is of the firm of Forrest & Co. The happy couple left on the steamer *Para* for a wedding trip of about three months, during which time they will visit the West Indies and Mexico.

Howard & Co.'s, celebrated establishment on Fifth avenue makes an unusually brilliant display for the holidays. Some of the finest gems in this country are to be seen in their show windows, among which are diamonds, rubies, pearls, sapphires, etc., set simply and in combination. Each object of adornment is a gem in itself. The establishment is lighted by electricity, and the effect of the brilliant light, as reflected on the precious gems displayed, is wonderously beautiful. This display attracts the attention of all passers on Fifth avenue.

John Moore, alias Thompson, a professional burglar from New York, who was jointly indicted with Chas. H. Mayhan, alias Mason, for robbing the safe of Myron Dubois, a jeweler, at Ellenville, have been found guilty. Both Moore and Mayhan were sentenced to five years' imprisonment at Clinton State Prison. Moore is thirty-nine years old and was born in Ireland. Mayhan was born in Boston and is forty-two years old. Both are expert cracksmen and have served several terms in prisons in this and other States.

Quite an interesting discussion has been going on in the daily press relative to adapting watches to the twenty-four consecutive hour dials, and it is asserted that there have to be material changes made in the movements to accommodate the dial. It is amusing to note the "chunks of wisdom" that these self-styled experts give utterance to. The facts are simply that to make the change it is only necessary to change the number of teeth in the hour wheel and to make the pinion of the minute wheel conform to it. This can be done at trifling cost in Waltham watches.

It is suggested that at the annual meeting of the League, to be held on the 16th inst., absent members be permitted to vote by proxy. Before this can be done it will be necessary to amend the constitution and by-laws. The proxy business in the management of corporations, especially of one that is purely benevolent in its objects, is fraught with too much danger to be accepted without due consideration. In complying with it there would be a possibility of over-zealous men obtaining control and subverting objects for which it was organized. The present system has been found satisfactory thus far and should not be disturbed.

There is on foot a movement for the organization of a Jewelers' Mutual Insurance Company for the purpose of insuring goods in the hands of travelers against all hazards. This Association will probably be organized during the present month, and will include in its membership the leading houses in the trade. While the Jewelers' Protective Union throws a certain amount of protection around travelers, it does not indemnify owners of goods for their loss. It is the purpose of the proposed organization to do this. There is need for such an association, and we do not doubt but it will be a success, but would suggest that it be united with the Protective Union.

Mme. Vacheron-Chossat, the oldest inhabitant of Geneva, died on November 2d, in the one hundred and second year of her age, having been born on August 27th, 1782. She retained her faculties almost unimpaired to the last, and survived all her children. Mme. Vacheron (Chossat was her maiden name) belonged to one of the most respectable families of the canton; her father was Mayor of Carouge at the beginning of the First French Empire. She was married in 1810, and her son, M. Cesar Vacheron, was the founder of the first factory in Switzerland for making watches by machinery. Mme. Vacheron's grandchildren are past middle age, her great grandchildren are men and women, and there is the most ample evidence that she had reached the age assigned to her.

Three masked men, armed with revolvers, entered the house of Joseph B. Heckler, a jeweler doing business at Mainland, N. J., compelled the family to throw up their hands under the pain of instant death. Mr. Heckler, who was about entering the house at the time, started off for assistance, when he was met by a fourth masked man. Mr. Heckler grappled with the man, and during the struggle tore his mask off. He failed, however, to recognize him. He cried loudly for help and the burglars were frightened away. Mrs. Heckler was injured by being knocked down with a chair. The burglars did not succeed in getting any valuables. They were well armed and provided with ropes and gags. This is the second time in three months that Mr. Heckler's house has been visited by burglars. The first time they carried off a large amount of jewelry.

Samuel Newman, alias Goldstein, an old professional thief, has again come to grief. Newman recently went into Thomas Kirkpatrick's jewelry store, at Broadway and Twenty-second street, and asked to see some diamond jewelry as he was anxious to make some purchases for Christmas presents. Detective McCloskey, who is detailed in the store, recognized him immediately and watched his movements closely. One of the clerks displayed an assortment of jewelry to Newman, who, while examining the goods, threw his gloves on the show case in such a manner that they completely covered a diamond bracelet valued at \$450. None of the articles displayed appeared to suit him, and, as he picked up his gloves to leave the store, he took up with them the diamond bracelet. When he reached the door the detective arrested him and took the bracelet from him. The accused was remanded for examination. He has been recently discharged from Sing Sing Prison, where he served two years and a half for stealing.

The surplus of the Chicago Fire Fund, made up by the contributions of the members of the trade for the benefit of the sufferers by the great fire in that city, has at last been disposed of by order of the court. Through the persistent efforts of Mr. Woglom, the President of the League, he has secured for that society nearly \$5,000 of what remained of this fund, and the balance has been turned over to the City Chamberlain of New York. Those gentlemen who refused to devote their share to the League will have to bring suit against the Chamberlain for its recovery. Should any undertake this, they will find all sorts of legal obstacles interposed, and after trial and re-trial, appeals, orders and motions, they are liable to be beaten at last. They will find that it will be economy to give their claims to the lawyers at the outset as part payment for the work they will have to do to recover the money. Had they all united in assigning their claims to the League, they would all have been determined by one suit and the League, and consequently the trade would have enjoyed the money. Mr. Woglom is entitled to much credit for what he has accomplished in this matter. The trustees of the fund are happy to be finally relieved of this trust.

WATERBURY CLOCK CO.,

MANUFACTURERS OF

CLOCKS,

Novelties and Materials,

No. 10 CORTLANDT ST., N. Y.

— AND —

No. 63 WASHINGTON ST., CHICAGO.

Factories, **WATERBURY, CONN.**

M. BAILEY, Treasurer.

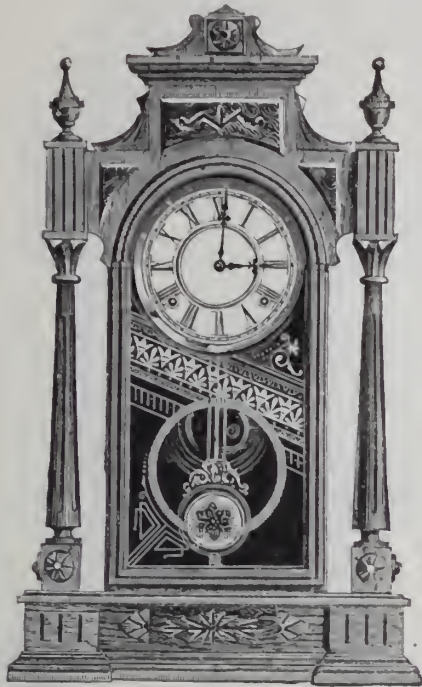

DUNKIRK.

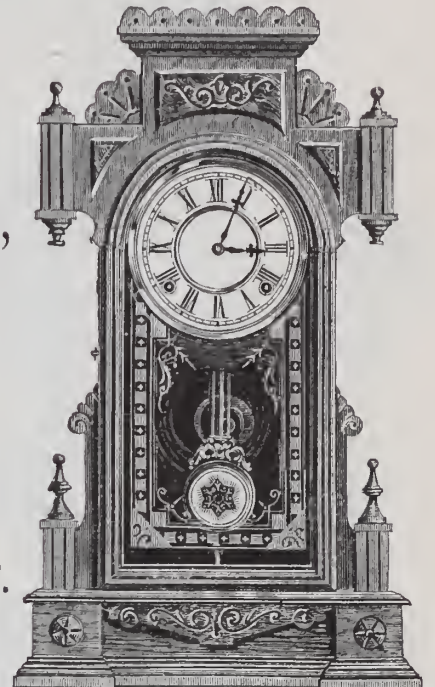

PAPIDAN.

The Ansonia Clock Co.,

Mantel Clocks.

Office Clocks.

Regulators.

Pillar Clocks.

Tower Clocks.

BRONZES.

Nickel Clocks.

Wood Clocks.

Iron Clocks.

Plush Clocks.

Marble Clocks.



"No. 8 MARBLEITE."

8-Day, Visible Escapement, Half-Hour Strike, Cathedral Gong, Back-Action Attachment.

MARBLEITE CLOCKS,

Richer in Appearance and
More Durable than
Black Marble.

The Natural Polish of the Material
Produces the Most Beautiful
Jet Black Surface.

IN A

VARIETY OF STYLES.

CHICAGO,
64 Washington St.

NEW YORK,
11 to 19 Cliff Street.

LONDON,
128 Minories.

W. L. GILBERT CLOCK CO.

GEORGE B. OWEN, General Manager.

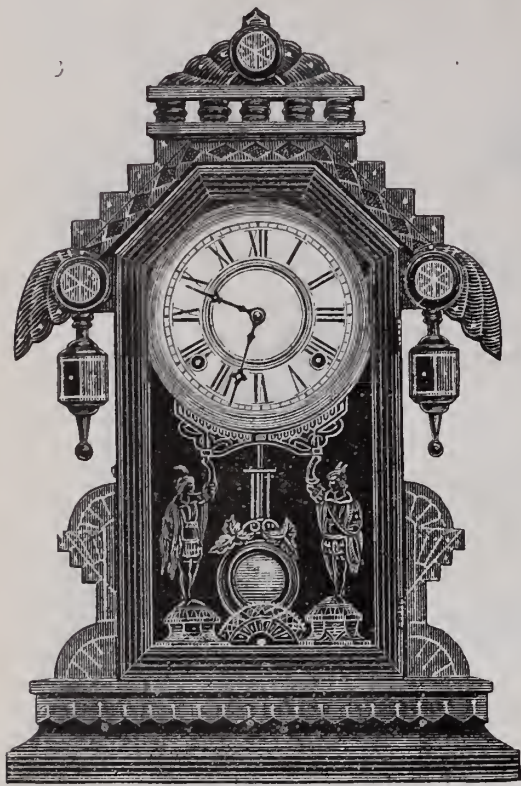

LEBANON.—Walnut.
8 Day Strike.
Height 20½ inches. 6 inch Dial.

Salesrooms:

No. 6 Murray St., N. Y.
54 & 56 Madison St., Chicago.

Factories:

WINSTED,
Conn.

MANUFACTURERS OF

Walnut, Veneered and Other Clocks

IMPORTERS OF

Marble and Cuckoo Clocks.

*Catalogue and Price List Fur-
nished upon application.*



ENID.—Walnut.
One Day Strike.
Height, 21½ inches. 6 inch Dial.

E. N. WELCH MF'G CO.

AND WELCH, SPRING & CO.

MANUFACTURERS OF

CLOCKS, REGULATORS, PERPETUAL CALENDARS.

6 Warren St., New York,

E. C. HINE, TREASURER.

NO. 2 REGULATOR

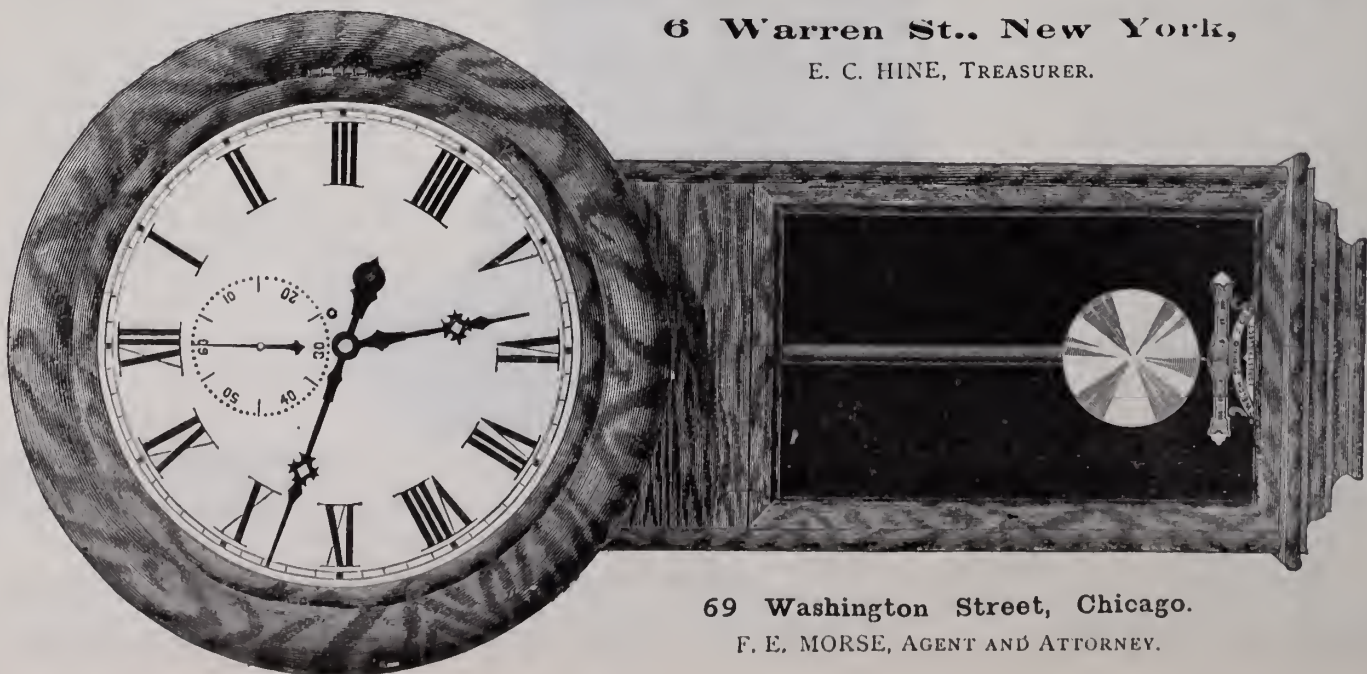

69 Washington Street, Chicago.

F. E. MORSE, AGENT AND ATTORNEY.

8 day.

18 inch Dial.

Height, 53 inches.
Weight.
Time.

"THE SARATOGA."—Patented.

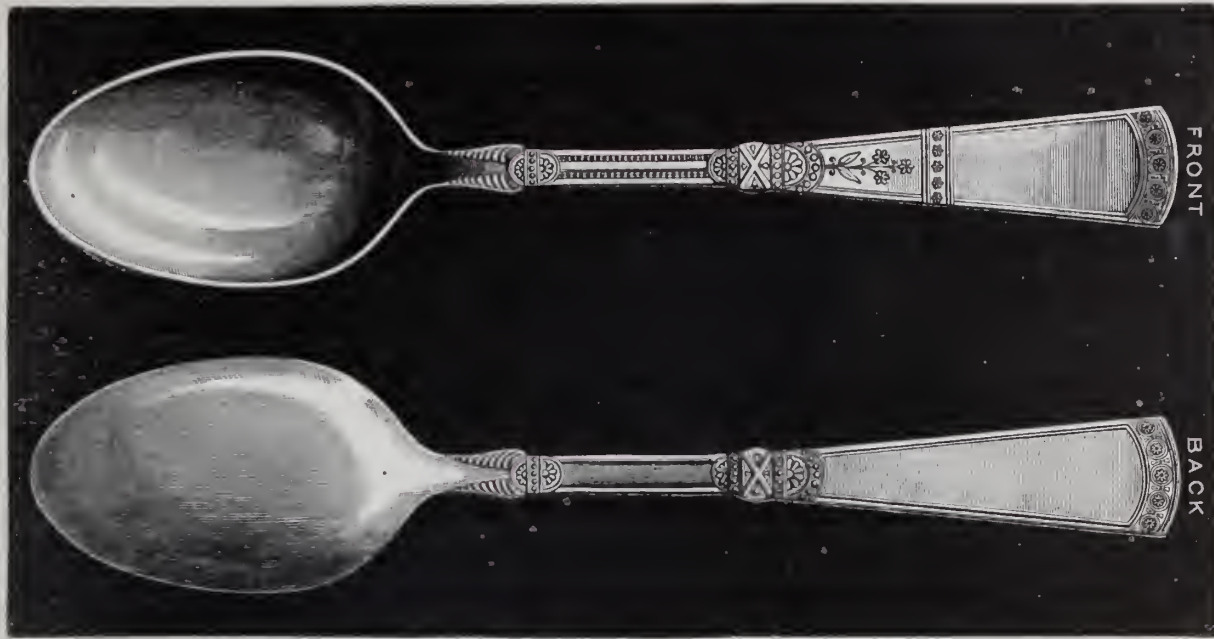

—: MADE BY :—

ROGERS & BROTHER,
690 BROADWAY, NEW YORK.
WORKS, WATERBURY, CONN.

CLEMENS HELLEBUSH,
MANUFACTURER, IMPORTER AND WHOLESALE JEWELER,
Dealer in everything required by the Jewelry Trade.

DIAMONDS.—Dealers will find in my stock an assortment of Diamonds unequalled in the West, embracing a choice variety of loose and mounted Stones in all qualities.
WATCH CASES.—In Gold and Silver, of all makers, to fit American Movements.
WATCH MOVEMENTS.—Include always a full stock of Waltham, Springfield, Hampden and Howard, together with a large assortment of fine and low-priced Swiss Watches.
SILVER PLATED WARE.—I have an unusually fine assortment of the choicest patterns of Flat and Hollow Ware of the best known manufacturers.
SOLID GOLD AND ROLLED PLATE JEWELRY.—This department is replete with Staple Goods and Novelties.
FRENCH CLOCKS.—Of our own importation, including all grades, with prices exceedingly low.
AMERICAN CLOCKS.—I am the General Agent in Cincinnati for the celebrated Seth Thomas Clocks, a full line of which will always be found in stock.
TOOLS AND MATERIALS.—In this department will be found everything required by Watch Makers.

Illustrated Catalogues sent to Dealers only upon Application.

CLEMENS HELLEBUSH,
77 West 4th Street, CINCINNATI, O.

—:o T H E o:—

BROOKLYN :: WATCH :: CASE :: CO.'S

EAGLE CASE.

The name was first used by this company seven years ago, to designate a case that was full 8-k. in all its parts, no piece, bearing, or joint, being used that was not full 8-k., or that would not stand the test of pure Nitric Acid without showing green. The Backs and Cap are absolutely free from solder, excepting what holds the joints. This Case has gradually won its way in the Trade, until its Standard of Quality is admitted to be just as reliable as that of gold dollars. To those who are disposed to investigate, it can be shown that no gold of less standard than 12-k. can compare at all favorably with the wearing properties of the

→* "B. W. C. CO.'S EAGLE CASE," *←

and cases can be shown that have been in use since 1875, which compare favorably with 14-k.; it is the Best Case ever offered the Trade for the money. All of these goods are stamped in the Cap with the trade mark (B. W. C. Co.) of the Company.

Any 8-k. red or yellow gold, except our Eagle quality, will not stand the acid test, and when kept in safe or show case will soon discolor, and when carried in the pocket will turn black.

This Company always has in stock the largest assortment in 18-k., 14-k., and Eagle Cases, of the latest designs and most desirable styles.

FOR SALE BY ALL THE PRINCIPAL JOBBERS.

LOUIS STRASBURGER & CO.

MANUFACTURERS OF

SWISS WATCHES AND MOVEMENTS.

IN ALL GRADES.

SPECIALTIES IN CHRONOGRAPHS, SPLIT CHRONOGRAPHS,
QUARTER SECOND SPLIT FLY-BACKS AND
REPEATING WATCHES.

Also a complete line of Chatelaines in Nickel, Silver and Gold, including the Latest Novelties in CHATELAINE WATCHES.

—AND—

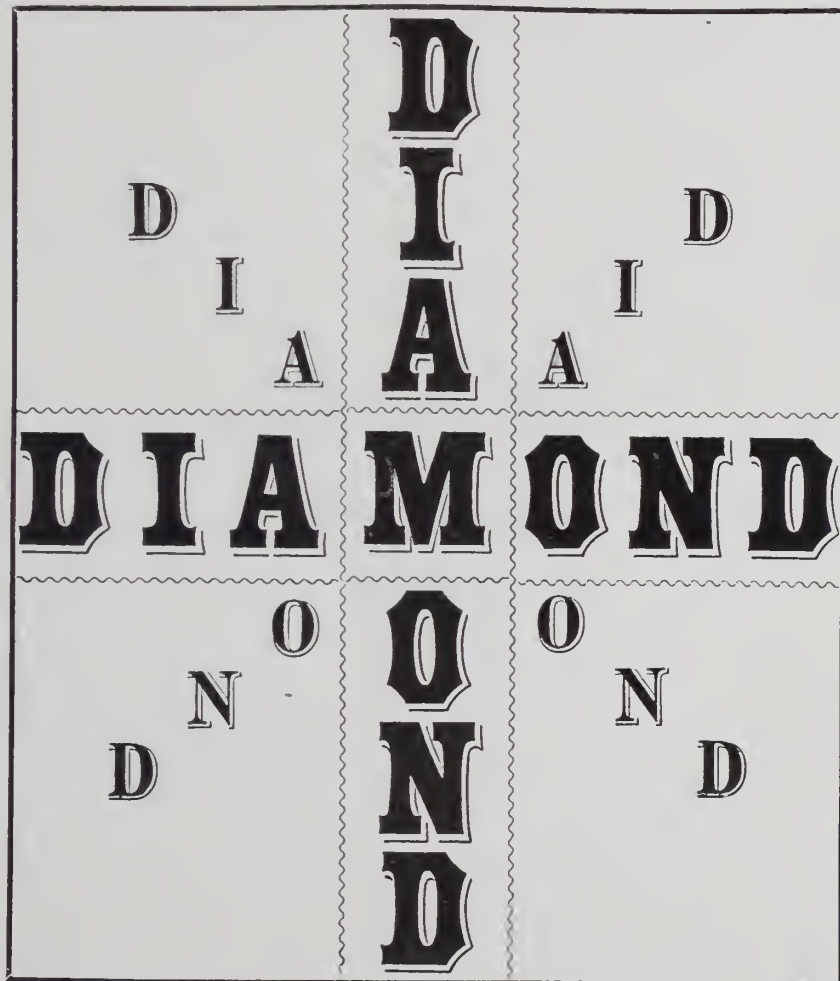

WATCH FACTORY,
11 RUE LEOPOLD ROBERT.
Chaux de Fonds, Switzerland.

DIAMOND ESTABLISHMENT,
30 BOULEVARD HAUSSMAN
Paris, France.

IMPORTERS.

We receive weekly regular invoices of New Goods, which enables us to present Fresh and Original Packages for Buyers to Select from.

15 MAIDEN LANE, NEW YORK.

JOSEPH FAHYS & CO.,
 MANUFACTURERS OF
 WATCH CASES,
 38 MAIDEN LANE,

78 Monroe Street, Chicago.

NEW YORK.

Attention is directed to the increased facilities introduced in our Factories for the manufacture of Watch Cases, and the superior class of goods we are now making. It is not too much to say that we are now producing the largest and most complete line of Silver Watch Cases in the country, and that for style, quality, workmanship and finish are not excelled by any other makers.



All cases of our manufacture are stamped with a fac-simile of this Trade Mark.

These goods are offered at a much lower price than any other cases sold in this market.

New styles and designs constantly appearing.

A Full Line of Cases always in Stock.

JOSEPH FAHYS & CO.,
 38 MAIDEN LANE, N. Y.

FOR SALE BY ALL THE LEADING JOBBERS IN THE COUNTRY.



Joseph Fahys & Co.'s Watch Case Factories at Sag Harbor, Long Island, N. Y.

ADOLPH GOLDSMITH,

SOLE AGENT FOR THE

RELIANCE WATCH COMPANY

38 MAIDEN LANE

NEW YORK.

Full Line of

Every Description of

Gold & Plated Jewelry

SWISS WATCHES
A SPECIALTY.



"RELIANCE,"
Nickel Stem Winder in all Sizes.



"RELIANCE,"
18 Size, to Fit Waltham Cases.



"RELIANCE,"
Ladies' 8 Size, to Fit Waltham Cases.

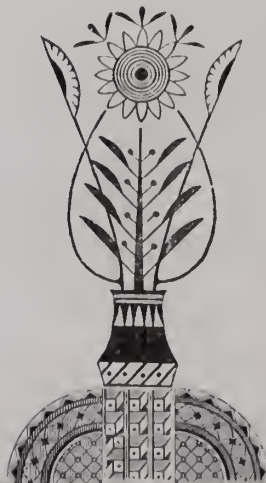

SPRING SEASON, 1883.
NEW DESIGNS NOW READY.

MIDDLETOWN



PLATE CO.

MANUFACTURERS OF

Superior Silver-Plated Ware.

In Tea Sets, Waiters, Berry Dishes, Baskets, Toilet Sets, Jewel Boxes, Presentation Goods, Epergnes, &c., of the Very Best Quality. Also Pitchers, Pitcher Sets, Swing Sets, Etc.

EVERY VARIETY OF HOLLOW AND FLAT WARE.

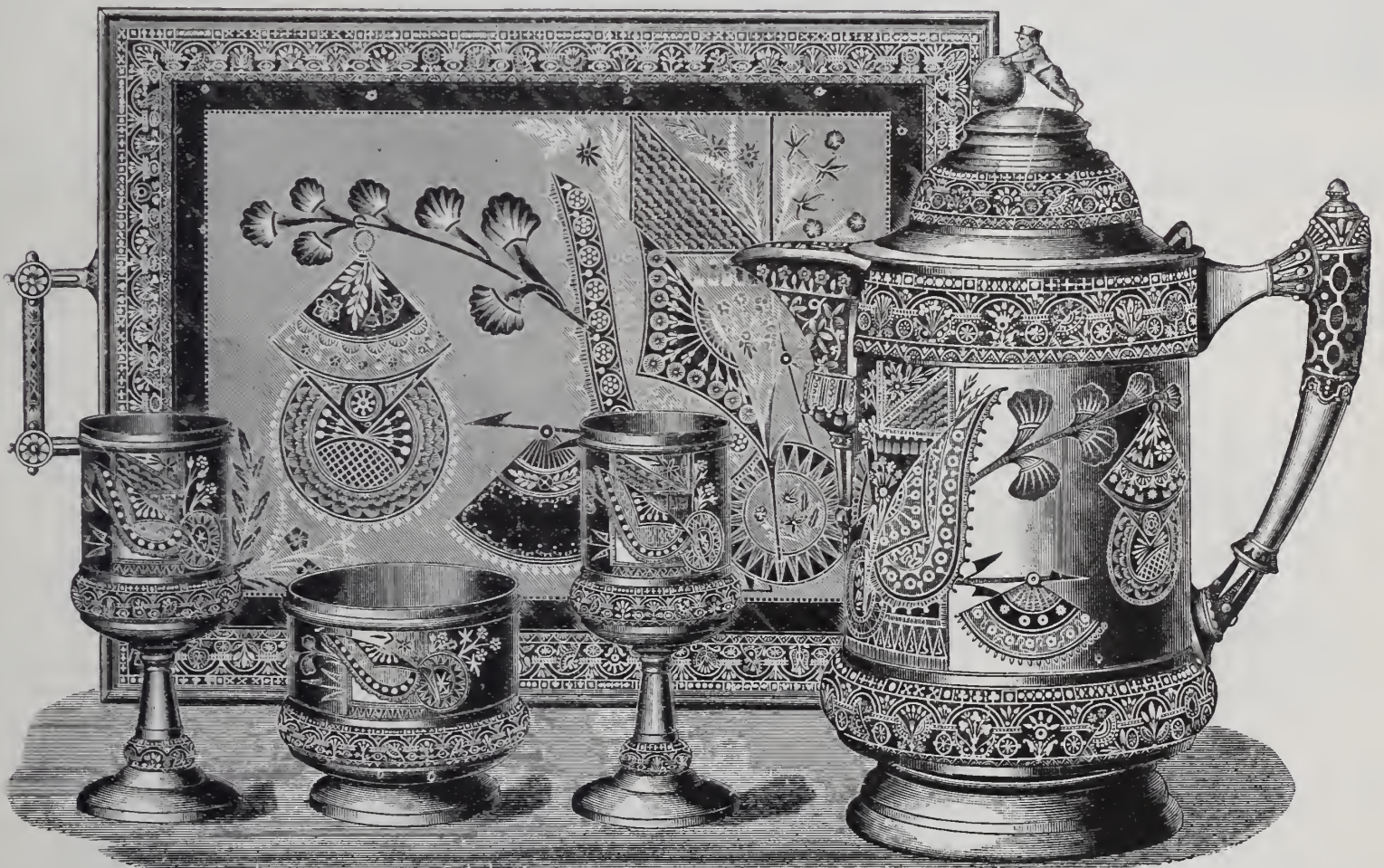

OFFICES.

*Middletown, Conn.,
120 Sutter Street, San Francisco, Cal.*

*13 John Street, New York,
101 & 103 State Street, Chicago, Illinois.*

Illustrated Catalogues and Photograph Albums sent to responsible Dealers.

→* 1883.*←

→* 1883.*←

THE DERBY SILVER COMPANY.

BIRMINGHAM, CONN.

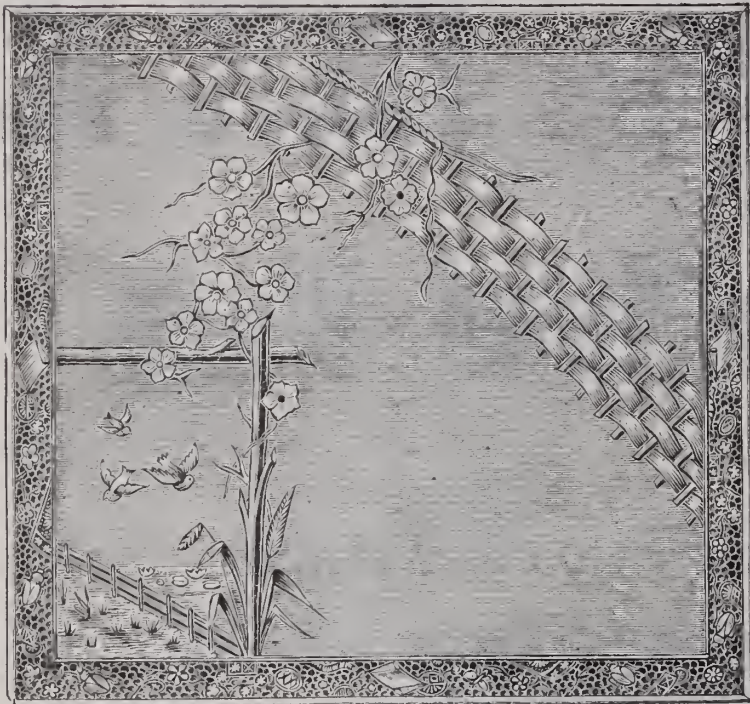

12 INCH WAITER.

→* MAKERS OF THE *

BEST QUADRUPLE PLATED WARE.

—o—

The immense rush of Holiday Trade has left us with **EMPTY SHELVES**, but we are now rapidly stocking up with a Large and Beautiful Assortment, partially represented in our New Illustrated Catalogue, which we furnished to the Trade upon application.

SIMONS, BROTHER & CO.,

MANUFACTURERS

A large decorative graphic featuring a central vertical column with the word "TIMBLES" written vertically in large, bold letters. Four diagonal banners radiate from the center, each containing a product category: "CANES" (top-left), "CHAIN" (top-right), "BRACELETS" (bottom-left), and "JEWELRY" (bottom-right). The entire graphic is framed by ornate, floral, and scrollwork borders.

→* Factory and Office *

611 Sansom St., Philadelphia →*

DAVID F. CONOVER & CO.

(SUCCESSORS TO WM. B. WARNE & CO.)

Manufacturers and Wholesale Dealers in

WATCHES and JEWELRY.

Wholesale Agents For

Rogers & Brother's Flat and Hollow Ware



Celluloid Eye-Glasses.

And Sole Agents for the

Patent Railroad Train Watch Chains, Nickel.

WHOLESALE AGENTS FOR

T. A. WILLSON & CO.'S Optical Goods.

Would invite attention to the following new grades of Steel Spectacles lately introduced in the market.

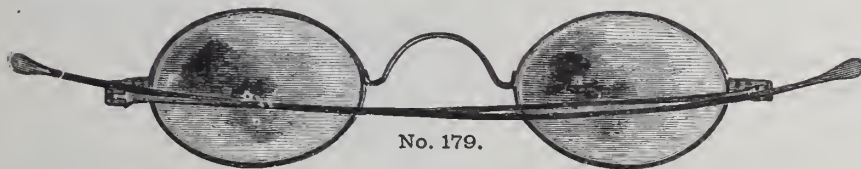

No. 179.

They are Steel, Full Tempered. Parts Interchangeable. Joints so constructed that wear is compensated for. Temple will not work loose and fall down as in old style joints. Nose-piece on No. 155 reinforced where it joins eye, giving extra strength with neatness.

PRIZE MEDALS AT ALL EXHIBITIONS WHERE EXHIBITED.

Patented July 31, 1877.

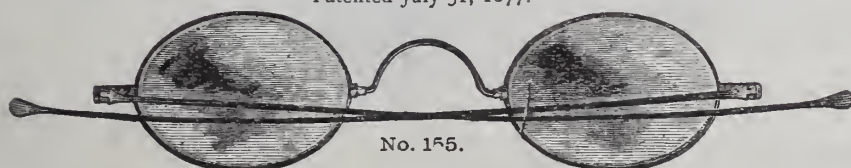

No. 155.

A SPECTACLE TEMPLE

THAT WILL

NOT WEAR LOOSE.

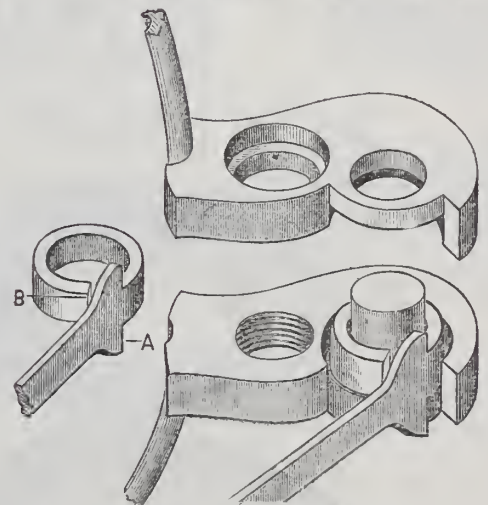

Patented May 13th, 1879, Re-issued June 8th, 1880.

A.—Stop for Temple, preventing Strain on Joint.

B.—Compensating eye, for taking up wear of joint. The eye of Temple is smaller than Stub Steel Joint Pin on which it works, and is left open at B, exerting a Spring Tension on Pin.

American Watch Wholesale Salesroom:

Southeast Cor. Chestnut and Seventh Sts., First Floor,

PHILADELPHIA.

DAVID F. CONOVER,
C. FRANK WILLIAMS
B. EDGAR RIGHTER.

SIMPSON, HALL, MILLER & CO.

WALLINGFORD, CONN.

MANUFACTURERS OF

ARTISTIC & USEFUL HOLLOW WARE,

→‡ ELECTRO PLATED UPON FINE HARD WHITE METAL. ‡←

Spoons, Forks, etc., plated upon the Finest Nickel Silver in Extra Double, Triple, and Sectional Plates Full lines of over Forty Staple and Fancy Pieces in each Pattern in Geneva, St. James, Countess, Windsor, Oval Thread, etc. Made under the supervision, and quality guaranteed and controlled by Wm. Rogers, formerly of Hartford and Meriden. (Wm. Rogers, Sr., died 1873).

WM. ROGERS, Wallingford, Conn.

No connection with any concern in Waterbury, Meriden or Hartford using name of Rogers in any form.

Store and Stock of Goods for Delivery in N. Y. and Vicinity, 36 East 14th St., Union Square.

Philadelphia, 506 Commerce St.—San Francisco, Cal., 530 Market St.—Montreal, Canada.—Baltimore, 6 German St.

JOBBER IN CINCINNATI, CHICAGO, ST. LOUIS, Etc.

BROWN & BROTHERS,

Finest Silver Plated Flat Ware,

SPRING TEMPERED SHANK. NEW AND CHOICE PATTERNS.



“FLORAL.”

We guarantee all our goods to be made of full quality 18 per cent. Nickel Silver, and weight of plate to be as indicated on the labels.

GOODS PACKED ONE DOZEN IN EACH BOX.

Factories, Waterbury, Conn.

Salesroom, 80 & 82 Chambers Street, N. Y.

THE MERIDEN BRITANNIA CO.,
MANUFACTURERS OF
FINE ELECTRO GOLD AND SILVER PLATED WARE,

Main Factories, MERIDEN, CONN.

BRANCH FACTORY, - - - - - HAMILTON, ONT.

SALESROOMS:

UNION SQUARE, N. Y.

154 STATE STREET, CHICAGO, ILLS.

134 SUTTER STREET, SAN FRANCISCO, CAL.

AND AT THE FACTORIES.

ESTABLISHED 1845.

WILLIAM H. BALL,

Successor to BALL & BARNARD.

—MANUFACTURER OF—

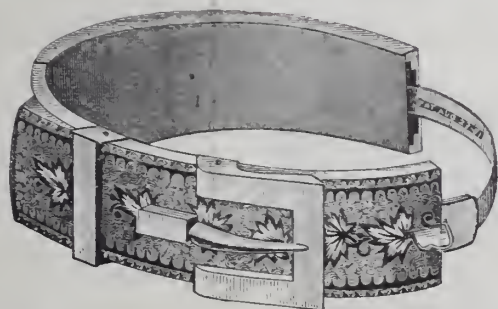

GOLD JEWELRY

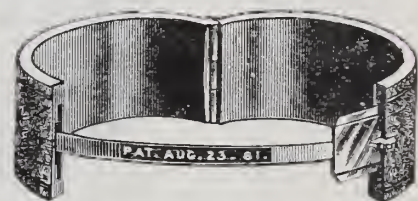

Specialty:—Bracelets,

Roman, Enameled and Engraved Band Bracelets, with the Safety Guard Attachment.
THIS SAFETY GUARD is GUARANTEED and costs nothing additional.

ALSO A FULL LINE OF

Bangle, Braided and Padlock Bracelets.

Office, 9 JOHN ST.,

Factory, Newark, N. J.

NEW YORK.

Goods Sent on Selection to Responsible Parties.

HOLMES, BOOTH & HAYDENS,

MANUFACTURERS OF

Electro-Silver Plated Spoons, Forks, Ladles, Fancy Pieces, Solid Handle Table Knives, Etc.,

OF THE FINEST QUALITY.

No. 49 CHAMBERS ST.,
NEW YORK.

No. 506 COMMERCE ST.,
PHILADELPHIA.
WORKS AT WATERBURY, CONN.

No. 18 FEDERAL ST.,
BOSTON.

The "Corona" Pattern.
NEW.

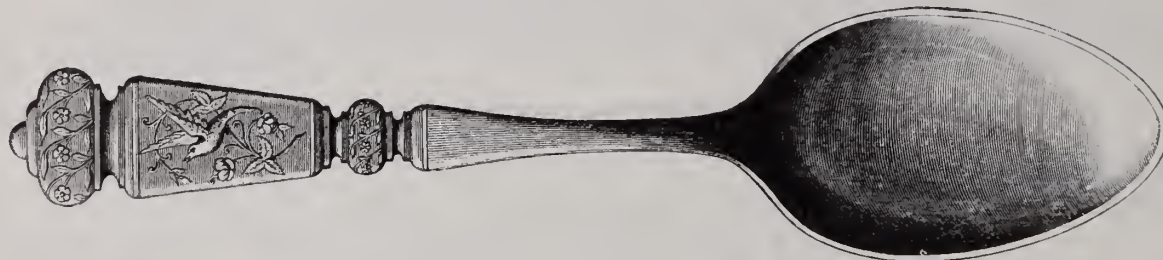

The "Corona" Pattern.
NEW.

The "Japanese" Pattern.

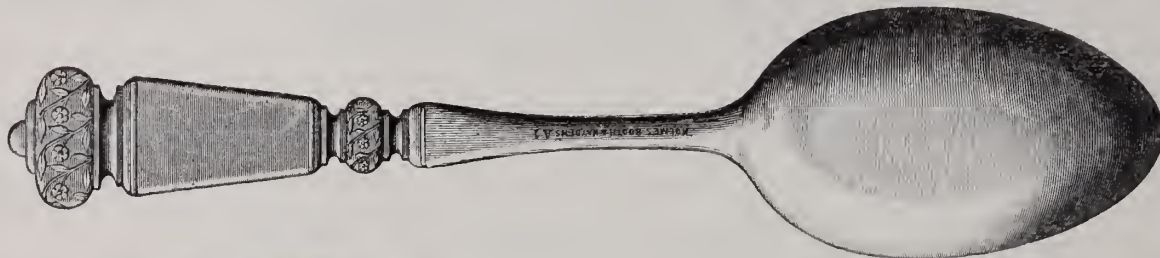

The "Japanese" Pattern.

The "India" Pattern.



The "India" Pattern.

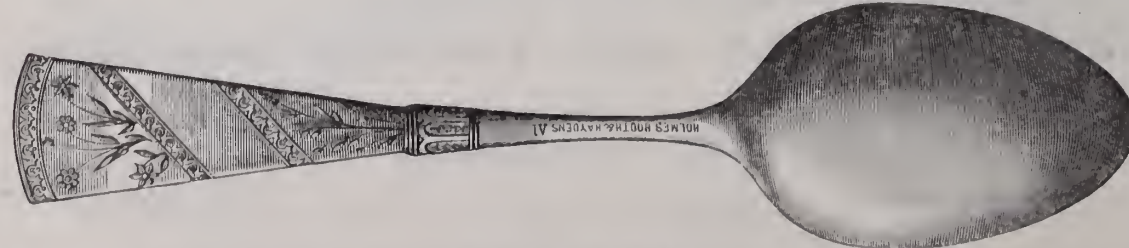

WE GUARANTEE OUR GOODS TO BE FIRST-CLASS IN EVERY RESPECT.

AMERICAN LEVER BUTTONS.

TO THE RETAIL TRADE :

It is a fact to be deprecated, that the purchases of certain Jobbers of Jewelry are influenced by low prices, rather than quality.

Such Jobbers very short-sightedly handle Lever Buttons of inferior quality, because they can make a larger profit, but they lose sight of the important fact, that what they make in the larger margin of profit, they lose in the smaller volume of business.

Not all Retail Dealers know just what make of Buttons they can rely upon, but the manufacturers of the AMERICAN LEVER BUTTONS beg to say in this connection, that

THEY GUARANTEE

ALL GENUINE HORSE-SHOE AND CLOVER GOODS

TO BE OF

SUPERIOR QUALITY, FINISH AND MECHANISM,

And authorize Retail Dealers to refund the purchase price in any case where the consumer has cause for dissatisfaction, and Jobbers are requested to furnish new buttons to their customers in exchange for any that may be returned as imperfect, the manufacturers guaranteeing to reimburse their jobbing friends for such outlay.

It will therefore be seen that it is to the interest of both JOBBER AND RETAILER to use the AMERICAN LEVER BUTTONS, and Retailers can always get these goods if they will ask their Jobber for them, and refuse to accept an inferior article.

Retail Dealers are reminded that the Caps or Linings to the Shoes of GENUINE AMERICAN LEVER BUTTONS are made of BRIGHT POLISHED ROLLED PLATE.

AS SHOWING THE DRIFT OF THE TRADE IN FAVOR OF

HANDLING GOODS OF WARRANTED STANDARD QUALITY,

AN EXTRACT FROM A LETTER DATED DECEMBER 12, 1882, FROM ONE OF THE LARGEST JOBBING HOUSES IN THE WEST, IS APPENDED BELOW :

* * * * "As for Spring Purchases, we have concluded to handle only one line of Plated Lever Buttons, and have a preference for the HORSE-SHOE AND CLOVER-LEAF BRAND. *Hereafter, your goods will have no competition in our stock.*" * * * * *

The above is an index of the sentiment which has been expressed either verbally or by letter, by quite a number of large and reputable Jobbing Firms throughout the country.

THE MANUFACTURERS SELL TO THE JOBBING TRADE ONLY.

THE BEST THE DUERBER



WATCH CASE

A WATCH CASE

As Good and as Perfect as

THE DUEBER WATCH CASE

Must be made in the same identical way we make them.



The Dieber Watch Case Manufacturing Co.,

NEW YORK

CINCINNATI

CHICAGO

ESTABLISHED 1847.

J. T. SCOTT & CO.,
 IMPORTERS, JOBBERS & MANUFACTURERS,
 No. 7 MAIDEN LANE, N. Y.

Would Respectfully Announce to the Trade that they this season offer a
 LARGE AND ATTRACTIVE STOCK OF DESIRABLE JEWELRY,
 of the latest and newest designs, and suitable to the requirements of all classes of
 dealers. Our Stock embraces a Full Line of

Lace Pins, Ear Rings, Rings, Bracelets, Bangles, Gold and Plated Chain,
 in fact, everything in the Jewelry line. Also Sole Importers of the celebrated

TRIUMPH-ROSKOPF WATCH,

universally acknowledged by Competent Workmen to be *the best Watch for the money made.*

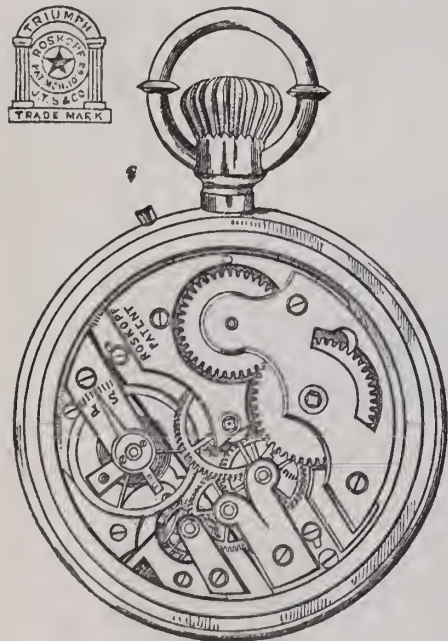

WITH INTERCHANGEABLE
 AND ADJUSTABLE
 ESCAPEMENT.

Cased in Superior Nickel, Open
 Faces, Stem Wind and Set.

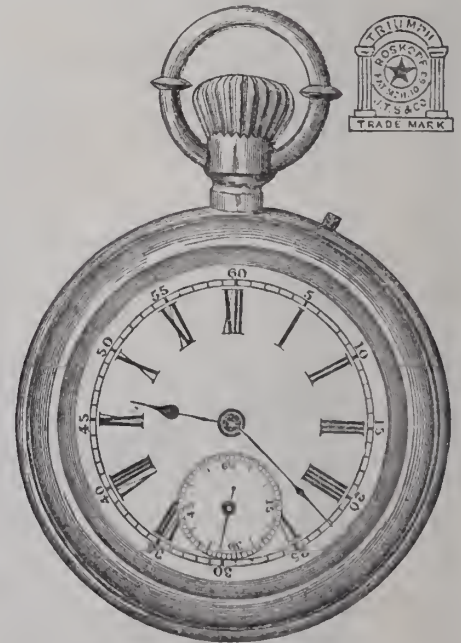
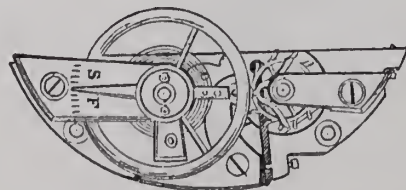

SOLE AGENTS OF THE OLD RELIABLE PATENT ROSKOPF WATCH.



A Full Line of American Movements and Cases.

All Orders committed to our care will Receive Prompt and Careful Attention.



© ROBERTS '86
Manufactory, 47, 49 & 51 Franklin Street, Newark, N. J.

MILLER BROS., JEWELERS,

7 MAIDEN LANE, NEW YORK.

SETS,
EAR RINGS,
CROSSES,
LOCKETS,
LACE PINS,
MEDALLIONS,

MOUNTED WITH

STUDS,
SCARF PINS,
COLLAR BUTTONS,
SCARF RINGS,
SLEEVE BUTTONS,
Etc., Etc., Etc.

Diamonds, Rubies, Sapphires, Pearls, Turquoise, Birds, Animal Heads and Fancy Ornamentations.

INITIAL GOODS A SPECIALTY.

All goods exclusively of our own manufacture, many of which are protected by MECHANICAL and DESIGN PATENTS.

CROSS & BEQUELIN,

21 MAIDEN LANE, N. Y.

IMPORTERS, MANUFACTURERS AND DEALERS IN

ALL GRADES OF WATCHES.

AGENTS FOR

CHAS. E. JACOT, J. ALFRED JURGENSEN

AND OTHER WELL-KNOWN SWISS MAKERS,

ALSO AGENTS FOR ALL AMERICAN WATCH COMPANIES.

Makers of the Centennial Watch, and Centennial Watch and Chronograph Combined; and the Centennial Callender Watch.

A FULL LINE OF WATCH TOOLS, MATERIALS, ETC.

ROGERS & BROS.' Plated Ware.

OPERA GLASSES, JEWELRY, ETC.

SOLE AGENTS IN NEW YORK FOR THE SALE OF THE ENGLE ENGRAVING MACHINE.

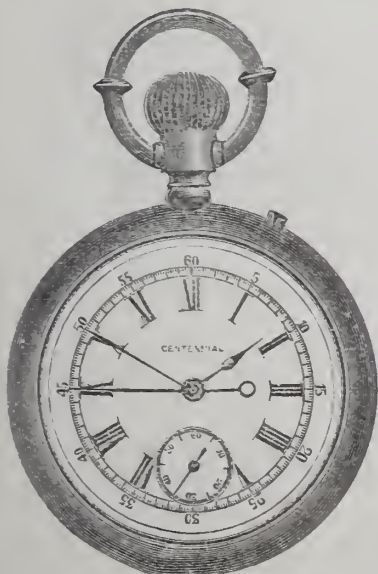

WM. SMITH & CO.,

MANUFACTURERS OF

GOLD and SILVER Chains & Jewelry,

Also a Large Line of SILVER RINGS.

OFFICE :

No. 25 Maiden Lane, New York.

MANUFACTORY—No 61 PECK STREET, PROVIDENCE, R. I.

W. & S. BLACKINTON,

MANUFACTURERS OF

ONLY

FINE ROLLED PLATE CHAINS,

Necklaces, Polished and Roman, of Latest Gold Designs. Also a Complete Line of Gents' and Ladies' Locketts and Pendants.

In consequence of the first-class reputation our goods have obtained, unscrupulous dealers have been selling goods of an inferior quality, represented as our manufacture. In order to protect ourselves, as well as dealers, all goods of our manufacture will hereafter bear this

TRADE MARK. **W&S-B** ★ TRADE MARK.

These Goods are for sale by all Wholesale Dealers.

CHAS. P. HEROLD,
MANUFACTURING JEWELER,
DIAMOND SETTER
AND DEALER IN
DIAMONDS.

916 CHESTNUT ST. PHILA.

N.B. A LARGE STOCK OF 18 Kt. DIAMOND MOUNTINGS,
SUCH AS CLUSTER AND SOLITAIRE RINGS, EARRINGS, LACE PINS,
SHAWL PINS, CROSSES, STUDS, AND GENTS' PINS,
&c, ALL OF WHICH ARE OF MY OWN DESIGNS AND
ARE MADE IN THE FINEST STYLE AND FINISH.

N. H. WHITE,

JOBBER IN

American-Waltham Watches,

Waltham Movements and Waltham Make of Gold and Silver Cases a Specialty.

A Full Stock of Ladd and Boss Filled Cases, also the New Patent Dust Proof Screw Bezel Filled Cases.

11 Maiden Lane, New York.

I not only advertise that I have the Waltham Goods, but HAVE CONSTANTLY ON HAND the Largest Stock carried by any jobber in the trade. To accommodate a constant demand, I carry a complete line of Cheap Gold Cases (8 karat, 10 karat, etc.), not made by the Waltham Co.

COMPLETE PRICE LIST OF ALL GOODS FURNISHED.

PATENT FOILED SOLID METAL BACK
RHINE STONE BRILL'S,
PATENTED FEB. 28, 1882.

PATENT FOILED
SOLID METAL BACK
RHINE STONE BRILL'S,
PAT. FEB. 28, 82.

Very Important to Jobbers and Retail Jewelers.

In buying White Stone Jewelry, be sure you get the "Patent Foil Solid Metal Back Rhine Stone Brilliant." The Cards must be stamped as above. The advantages over the PAINTED FOILS ARE:

- They are more Durable.
- are not affected by washing or dampness of air.
- retain their Lustre.
- preserve their Purity of Color.
- are sold at the same price as the Painted Foils.
- are sure to give satisfaction.

SEE THAT THE JEWELRY CARDS ARE STAMPED AS ABOVE.

E. E. KIPLING,
IMPORTER OF

PRECIOUS AND IMITATION STONES,
No. 6 MAIDEN LANE, N. Y.
Providence, WILCOX BUILDING, Weybosset St. Paris, 1 RUE RICHER.

Waltham, Elgin, Illinois,
Hampden, E. Howard & Co.
and Special Movements.

**392 WASHINGTON ST.,
BOSTON.**

P. O. Box 5259.

Watches, Jewelry,
Gold Chains, Gold,
Filled and Silver Cases,
Spectacles, Eye - Glasses,
Gold Head Canes, and Rogers &
Bro.'s Flat Ware.

**WHOLESALE
DEALERS.**

Price List of Movements and Cases
Sent on Receipt of Business Card.

ESTABLISHED 1837.

VICTOR BISHOP & CO.

IMPORTERS OF

DIAMONDS,

**Rubies, Sapphires,
Emeralds & Pearls.**

**Enamel Paintings, Roman Pearls,
Copper, Platinum and Iridium.**

33 MAIDEN LANE, NEW YORK.

House in Paris, 66 Boulevard de Sebastopol.

LOUIS A. SCHERR & CO.

Importers and Wholesale Dealers in

Watches, Jewelry,

WATCH MATERIALS, TOOLS, GLASSES, &c.

Spectacles, Silk Guards, &c.

Wholesale Agents for American Watches.

**No. 726 CHESTNUT STREET
PHILADELPHIA.**

AGENTS FOR THE WHITCOMB LATHE

AGENTS FOR W. F. NYE'S WATCH AND CLOCK OILS.

TO THE TRADE.

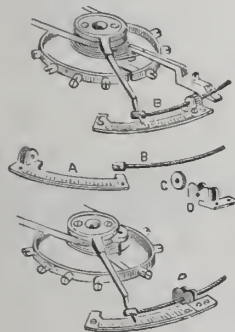

Your attention is called to the Improved Awalt Patent Watch Regulator, Style B. It is made of Nickel, Index and all combined, with Nut C and Screw B made of Fine Steel, to fit all full plate watches, by removing the Index and using the same screw holes and screws on the watch.

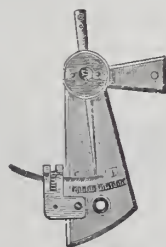

Style D Regulators have been improved in shape and finish, and fit both full plate and bridge watches, are made in Gilt and Nickel, with Nut C and Screw B of Fine Steel. Try them, and it will surprise you to find how much they will aid in making a watch realize you a nice profit.

JOHN A. AWALT, Manufacturer,

ALSO JOBBER IN

WATCHES, CLOCKS, JEWELRY, Etc.,

177 Vine Street,

CINCINNATI, OHIO.

ESTABLISHED 1834.

FOR THE SPRING TRADE.

E. IRA RICHARDS & CO.,

MANUFACTURERS (Exclusively) OF

FINE ROLLED PLATED JEWELRY.

The Largest and Choicest Stock in the Country.

SPECIALTY FOR THE COMING SPRING,
BAND & BANGLE BRACELETS & Extra Quality ROLLED PLATED CHAINS.

These Vest Chains are produced to meet the demand for a
ROLLED PLATED CHAIN
that will wear for years. Each Chain bears the initial letters of our firm.

No. 200 BROADWAY, NEW YORK.
2d STORY, FRONT.

GOODS SENT ON SELECTION TO RESPONSIBLE PARTIES.

JOHN W. STEELE,

MANUFACTURER OF

FINE GOLD JEWELRY,

—AND—

BRAINERD'S

PATENT

LOCKETS

Patented June 17, 1874.



No. 9 Maiden Lane, NEW YORK.

MATERIALS
AND
OPTICAL GOODS.

Agents for the

LANCASTER, PA., WATCHES.

A. FRIEDENTHAL & CO.

Manufacturing Jewelers,

AND IMPORTERS OF

WATCHES,

43 MAIDEN LANE, NEW YORK.

WHITE,
BLACK,
MOTTLED,
OR
BLOOD
STONE



Mounted in
GOLD,
SILVER,
OR
SOLID
NICKEL,

For all 18 Size American S. W. Movements.
Mounted in Gold and Silver for 14 and 16 Size.

Perfected and Warranted.

FOR SALE BY THE JOBBING TRADE

and by the Manufacturers,

Colby & Johnson, 17 Maiden Lane, N. Y.

DAY & CLARK,

MAKERS OF

FINE ROMAN GOODS,

BANGLES,

Plain and Ornamented Bead Necklaces.

Every style and size of Diamond Ear Ring Covers,

LACE PINS AND EAR DROPS.

STONE SEALS AND LOCKETS.

192 Broadway, cor. John Street,

FACTORY, NEWARK, N. J.

NEW YORK.

E. STITES' SONS,

White Stone Goods,

Bangle Bracelets, Rings,

AND

Bangle Charms

A SPECIALTY.

MANUFACTURING JEWELERS,

EAR RINGS,
BALL PINS,
SLEEVE BUTTONS,
COLLAR BUTTONS,
STUDS,
AND SCARF PINS.

14 JOHN STREET, N. Y. Factory, NEWARK, N. J.

SUSSFELD, LORSCH & NORDLINGER,

IMPORTERS OF

Optical and Mathematical Instruments,

Watchmakers' Tools, Materials, Etc.

SPECIALTIES:

BARDOU & SONS' Universal Opera Glasses. U. S. Army and Navy Glasses.
Rifle Range Telescopes, Etc., Etc.

LA REINE Opera and Marine Glasses.

CROWN Spectacles and Eye-Glasses.

PARADIS MAINSPRINGS.

PARAGON TOOLS.

13 MAIDEN LANE, NEW YORK.

16 Rue D'Enghien, PARIS.

LODWICK & NOLTING,

WHOLESALE JEWELERS,

Corner 4th and Walnut Streets,

CINCINNATI,

OHIO.

NO GOODS AT RETAIL.

SILLCOCKS & COOLEY,

MANUFACTURERS OF

JEWELRY.

IMITATION DIAMONDS AND BAND BRACELETS

A SPECIALTY.

Hereafter Our Bracelets will be Fitted with John A. Riley's Patent Spring,
thus avoiding the use of Chains.

OUR STOCK

Consists of a Large and Varied Assortment of FINE IMITATION DIA-
MOND GOODS, embracing all the Newest Designs, Exquisitely
Finished, and Equal to the Best Diamond Work.

ESPECIAL ATTENTION

Is directed to our FOIL BACKED GOODS, that have a Brilliancy only
equalled by the Genuine Stone. HAIR ORNAMENTS in Imitation
Stones, Mounted in the Most Attractive Styles.

No. 4 Maiden Lane,

New York.

FACTORY, No. 14 MAIDEN LANE



Sterling Silver Tablewares.

All Silverwares made by DUHME & CO. bear the mark



and are guaranteed 925-1000 FINE, the standard for English sterling.

DUHME & CO. are among the few prominent manufacturers of Sterling Silverwares in the United States who do not produce rolled or machine made wares, their entire product being hand made, hand engraved, and hand burnished, by which processes, only, can the best results be realized. Fourteen styles of Spoons and Forks, complete lines of larger pieces, also chests of Silver, constantly in stock, or made to order, at

DUHME & CO.'S,

Corner Fourth and Walnut Streets,
CINCINNATI, OHIO.

R. WALLACE & SONS M'FG CO.,

MANUFACTURERS OF

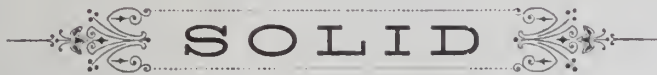

SILVERWARE,

GUARANTEED $\frac{1000}{1000}$ FINE.

WALLINGFORD, CONN.

H. P. HILDRETH,

MANUFACTURER OF

SOLID GOLD RINGS,

PLAIN AND ORNAMENTAL,

10 JOHN STREET, NEW YORK.

Factory, 1305 ATLANTIC AVENUE, Brooklyn.

Best Quality of Goods at Lowest Cash Prices.

Send for Price List, as I have no Agents.

COX & SEDGWICK,

26 JOHN STREET, N. Y.,

Makers of Patent Black Onyx Bracelets

Also Black Onyx Faceted Bead Bracelets,
AT THE LOWEST PRICES.

COLORED
AND

Turquoise

Lace Pins,
Ear Rings,
Lockets,
Bracelets,
Sleeve

Buttons,
Searf Pins,

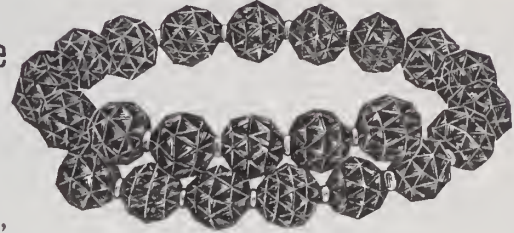

ONYX

Lace Pins,
Ear Rings,
Medallions,
Necklaces,
Chatelaines
Sleeve Buttons
Ladies & Gents
Vest and
Guard Chain.

Black Onyx Pins, Ear Rings and Lockets for 1, 3 and 5 Diamonds.

GOODS SENT ON APPROVAL TO RESPONSIBLE FIRMS.

WOOD & HUGHES,

STERLING

SILVERWARE MANUFACTURERS,

New York Agents for the Derby Silver Co.'s

Fine Quadruple Plated Ware,

No. 16 John Street, N. Y.

206 Kearney Street, San Francisco, Cal.

R. R. HASKELL, Agent.

J. B. & S. M. KNOWLES,

MANUFACTURERS OF

Sterling Silver Ware,

No. 20 MAIDEN LANE,

NEW YORK.

FACTORY, PROVIDENCE, R. I.



CARTER, SLOAN & CO.,
MANUFACTURERS OF ALL KINDS OF

GOLD JEWELRY,

BROADWAY AND FOURTH STREET,
NEW YORK.

A. CARTER, JR.
A. K. SLOAN,

C. E. HASTINGS,
G. R. HOWE.

BALDWIN, SEXTON & PETERSON,
MANUFACTURERS OF

FINE JEWELRY,
DIAMOND AND STONE CAMEO GOODS,

GOLD CHAINS, &C.,
Importers of Diamonds, Pearls, Emeralds, Rubies, &c.,
WHITING BUILDING,

Cor. Broadway & Fourth St., N. Y.
120 SUTTER STREET, SAN FRANCISCO, CAL.

J. F. Chatellier,
Manufacturing Jeweler,
692 & 694 Broadway,
New York.



TRADE

MARK.

STERLING.

Whiting Manufacturing Co.

SILVERSMITHS,

BROADWAY & FOURTH ST., N. Y.

ESTABLISHED 1837.

TAYLOR & BROTHER,

Old House READ, TAYLOR & CO.,

Importers of Diamonds and Pearls,

—)AND(—

MANUFACTURERS OF DIAMOND JEWELRY,

21 Holborn Viaduct, 676 Broadway,

LONDON.

NEW YORK.

ESTABLISHED 1813.

THOMAS G. BROWN & SONS,
Newark, N. J., & 5 Bond Street, New York.
MANUFACTURERS OF

ARTISTIC JEWELRY
FOR PRESENTATION,

including Prizes for ROWING, RIFLE SHOOTING, ARCHERY and
all ATHLETIC SPORTS.

COLLEGE SOCIETY PINS AND CLASS RINGS, ALSO BADGES FOR MILITARY
AND CIVIC BODIES IN ALL METALS.

Employing able Designers, and having all work, both in Designing and Manu-
facturing, done in our own factory, we can submit, for the inspection of those
interested, entirely original designs, appropriate in style, and not to be seen else-
where.

Estimates and Designs will be sent to Reputable Dealers when desired.

ALFRED H SMITH & CO.
IMPORTERS OF

DIAMONDS

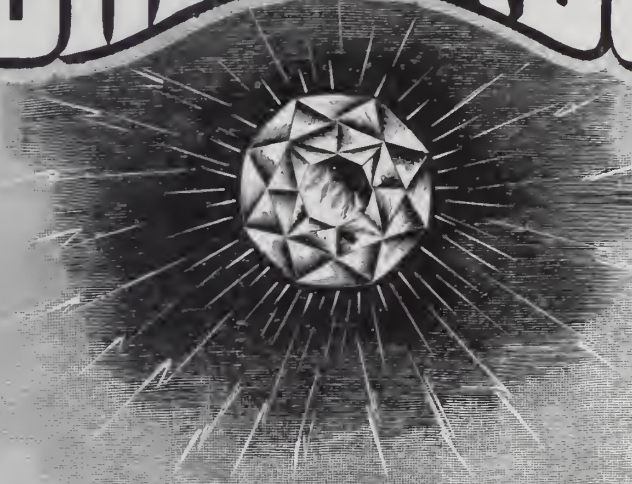

182 BROADWAY
COR OF JOHN ST.

NEW YORK

NO 125 STATE STREET CHICAGO
33 HOLBORN VIADUCT LONDON

S. J. COX SC. DEL. N. Y.

THE

NEW HAVEN CLOCK CO.

MANUFACTURERS,
IMPORTERS,
DEALERS.

FACTORIES.
NEW HAVEN, CONN.

GENERAL OFFICE AND SALESROOMS.
62 READE STREET,
New York.

WESTERN OFFICE AND SALESROOMS.
31 WASHINGTON ST.,
Chicago, Ill.

EUROPEAN OFFICE AND SALESROOMS.
16 PITT STREET,
Cleveland Sq., Liverpool,
England.

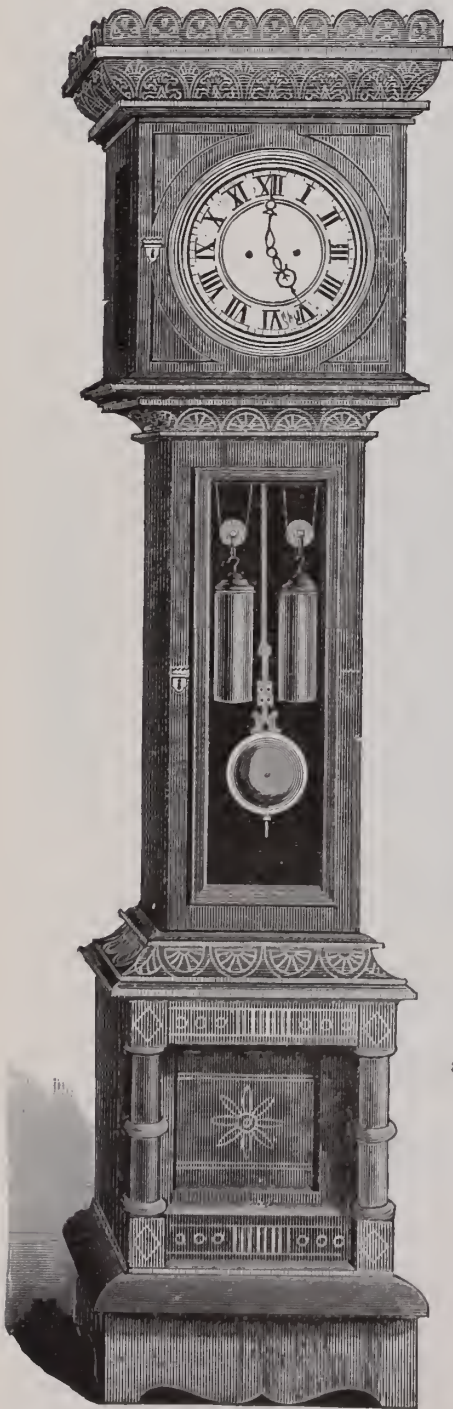
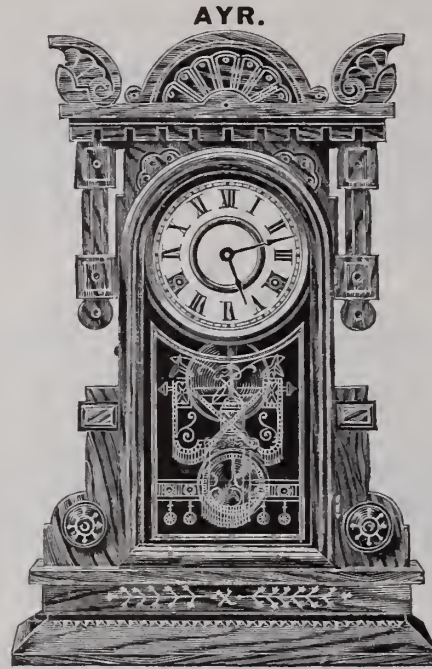

CARVED WOOD,
English Regulator.

WE have again introduced many Popular Improvements as well as New Designs, combining the most desirable effects and thorough construction with moderate prices. Among these will be found our new 8-day Pendulum Movements, striking hours and half hours on Gong Bells with Cathedral tones. By this means we bring within the reach of all the best selling points of the most expensive imported clocks.

We also call attention to the fact that we sell these Cathedral Gongs either separately or fitted in any of our Visible Pendulum Clocks at a moderate extra charge.

We now have the greatest facilities for

IMPORTING

all kinds of

French Clocks

and

BRONZES,

and are pleased to ask our patrons to give this fact their careful attention and allow us, by a trial, to show them that we can offer a better and cheaper assortment than any other house.

Send for Complete Catalogue of All Styles.



MARBLE,
Imported.

REED & BARTON,
Taunton, Mass.

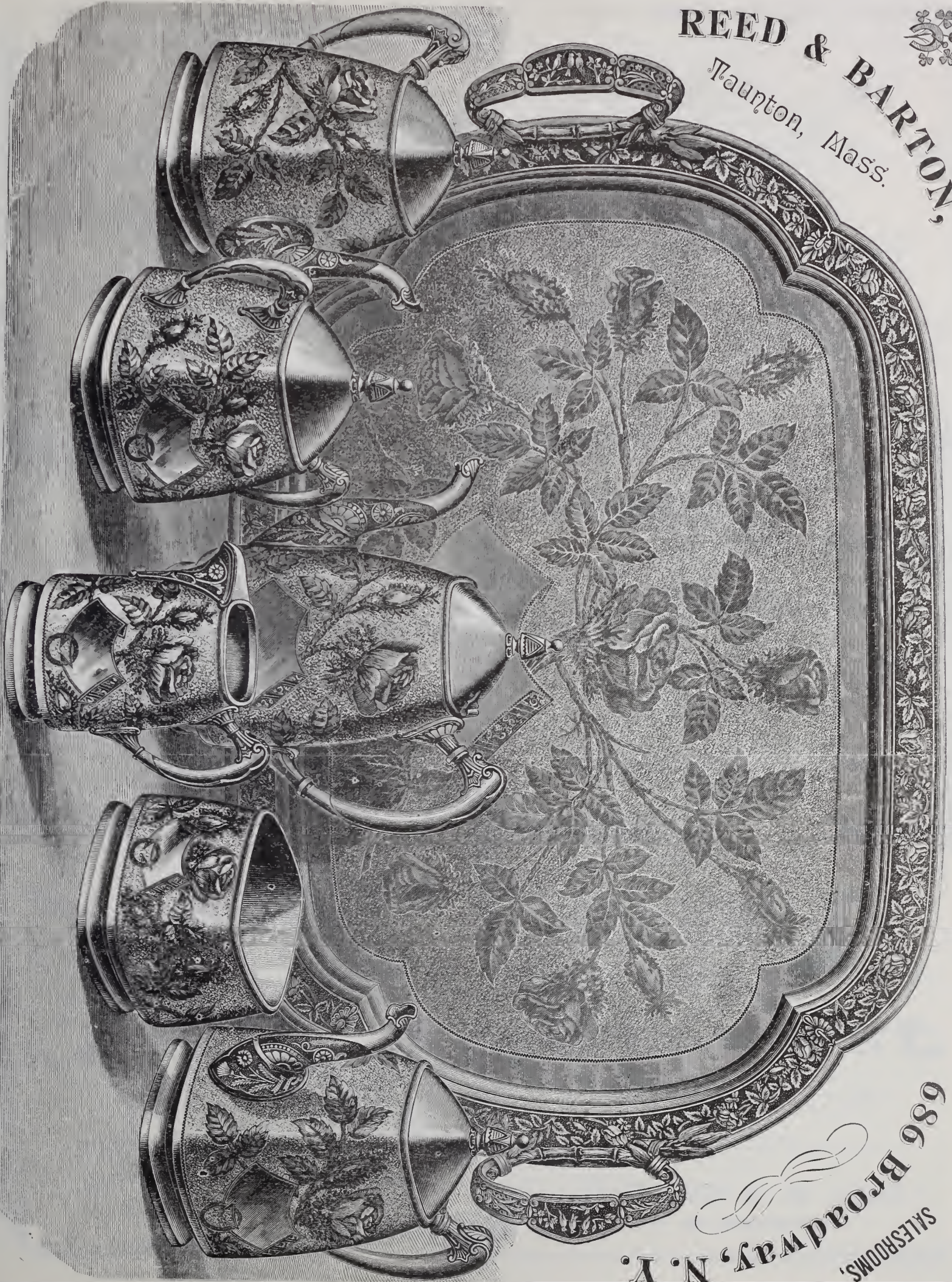

SALESHOOMS,
686 BROADWAY, N. Y.

ESTABLISHED 1834.

G. & S. OWEN & CO.,

—MAKERS OF—

FINE ROMAN JEWELRY, &c.

—& BOX and GLASS PINS,

—AND—

Black Onyx and Pearl Goods,
OF EVERY DESCRIPTION.

All Goods sold by us are exclusively of our own manufacture and
are warranted 14 K. Fine, and stamped as such when possible.

No. 3 Maiden Lane, New York.

W. H. SHEAFER & CO.,

MAKERS OF

Bangles, Buttons, Ear Rings, &c.,

ALSO

FINE WHITE STONE AND IMITATION
PEARL GOODS.

SPECIALTY:

Fine Gold Band Bracelets.

FACTORY:

612 Chestnut St., Philadelphia.

BRANCH OFFICE:

15 John St., New York.

RIPLEY, HOWLAND & CO.,

MAKERS OF

FINE JEWELRY.

SPECIALTIES:

DIAMOND MOUNTINGS, with Platinum Tips.
ENGRAVED RINGS, STONE RINGS,

OFFICE, 17 MAIDEN LANE,
NEW YORK.

FACTORY, 383 WASHINGTON ST.,
BOSTON, MASS.

SAXTON, SMITH & CO.,

Manufacturers of

GOLD CHAIN

SOLE AGENTS

FOR THE

NEW PATENTED CHAIN BAR,

Containing a Detachable Pencil.

FACTORY:
183 EDDY ST.,
PROVIDENCE, R. I.

OFFICE:
14 JOHN ST.,
NEW YORK.

A. J. HEDGES & CO.,

MANUFACTURING

JEWELERS,

No. 6 MAIDEN LANE,

NEW YORK.

Factory, No. 90 MECHANIC ST.,
NEWARK, N. J.

A. W. FABER'S

CELEBRATED

Gold Pens & Pencil Cases.
TOOTH PICKS AND NOVELTIES.

Manufactured by

EBERHARD FABER,

Nos. 718 and 720 Broadway,
NEW YORK.

J. B. BOWDEN & CO.,
 MANUFACTURERS OF
SOLID RINGS
 Of Every Description.
 No. 1 MAIDEN LANE,
 Cor. Broadway, NEW YORK.

MOORE & HORTON,
 No. 11 Maiden Lane,
 NEW YORK.

JEWELERS.

SPECIALTIES:
 Stone Cameo, Onyx, Amethyst, Topaz
 and Pearl Rings.
 Studs, Collar and Sleeve Buttons.
 Also our fac-simile of Fine African Diamonds,
 with Foile Back, Mounted in Rings, Studs,
 Pins, Ear Rings, Scarf Pins, Lace Pins, &c.

JOHN F. SAUNDERS,
 Of the late firm of Buckenham, Cole & Saunders.

CHAUNCEY IVES.

SAUNDERS & IVES,
 IMPORTERS OF
DIAMONDS, PEARLS,
 And Other Precious Stones.
 Manufacturers of Diamond Mountings.
 No. 26 MAIDEN LANE, NEW YORK.

A Large Stock of FINE DIAMONDS, Mounted and
 Unmounted, kept constantly on hand.
 Goods sent on approval to any part of the country on receipt of
 satisfactory reference. All our goods ARE IN-
 SURED by us while in transit.

PERRY BROS.,

WARRANTED
 JOBBERS IN
WATKINS

AND JEWELRY,
 N. E. COR. STATE AND MONROE STS.
 CHICAGO, ILLINOIS.

STOCK ENTIRELY NEW.

G. W. PRATT & Co.,
 Manufacturers and Dealers in
Watches and Jewelry
 OF EVERY DESCRIPTION.
 ELGIN AND ILLINOIS MOVEMENTS
 IN ALL GRADES.
 Gold, Silver and Ladd Patent Cases.
 No. 14 JOHN STREET, NEW YORK.

DORRANCE, EDGE & CO.,
 Sole Manufacturers of the Celebrated
Woven Fabric Gold Chain,
 Elegantly Mounted Bracelets, OPERA, LEONTINE.
VICTORIA WATCH GUARDS & NECKLACES
 In all the Newest Designs.
 Our Stock is unusually complete, and in addition to the above a
 variety of NECKLACES, from 1½ to 40 dwts. each, to
 which we invite the attention of buyers.
 CHILDREN'S BRACELETS A SPECIALTY.
 15 JOHN ST., NEW YORK.
 FACTORY, 46 GREENE ST., NEWARK, N. J.

ESTABLISHED 1850.

JOHN T. MAURAN,

MANUFACTURER OF

→ FINE ROLLED PLATE GOODS ←

15 MAIDEN LANE, NEW YORK.

SPECIALTIES FOR THE SPRING.

FULL LINE OF

STONE LACE PINS IN RUBY AND SAPPHIRE DOUBLETS,
GARNETS, AND FOILED WHITE STONES,

Jet Lace Pins, Sets and Ear Knobs, Solid Gold White Stone Knobs,

ALSO

Full Line of Coral and Wire Sets, Lace Pins, Knobs, &c.

These Goods which are so well and favorably known to the Trade, bear this



as well as the same being stamped on the cards.

JULIEN GALLET & CO.

IMPORTERS OF



OF EVERY GRADE.

No. 1 MAIDEN LANE,

NEW YORK.

Webster's Silver Solution,

PREPARED BY

E. G. WEBSTER & BROTHER,

(Established 1859.)

Manufacturers of Quadruple
Electro Silver Plated Ware

14 MAIDEN LANE, N. Y.,

Expressly for Cleaning Silver and Silver
Plated Ware.

Jewelers will find this a valuable adjunct for
cleaning their stock, and a reliable article to
recommend to their customers.

Guaranteed entirely free from Cyanide, Acid,
Grit, or anything detrimental to the Finest
Wares.

Packed in Boxes containing 2 Doz. Bottles.

Price, \$1.25 per Doz., NET.



LEROY W. FAIRCHILD,

MANUFACTURER OF

STRICTLY FIRST-CLASS

GOLD PENS AND PENCIL CASES,

TOOTH PICKS,

→ AND NOVELTIES IN CHARMS. ←

Office, No. 1 John Street,

Factory, Broadway & 4th Street,

NEW YORK.

CHESTER MANCHESTER & CO.,

MANUFACTURERS OF

Gold and Silver Chains,

No. 13 HANOVER STREET,

PROVIDENCE, R. I.

ESTABLISHED 1833.

WELCH & MILLER,

JEWELRY
CASE MANUFACTURERS,

OF MOROCCO, VELVET, RUSSIA, BROCADE AND PLUSH.

TRAYS OF ALL DESCRIPTIONS.

Telescope Sample Cases with Flexible Trays.

Agents for Jewelers' Cotton and Twine.

A Large Stock Always on Hand.

169 BROADWAY,

NEW YORK.

MANUFACTURERS
OF
Everything in
BLACK ONYX JEWELRY
PLAIN, and {Ornamented with
 { Pearls and
 { Diamonds.

Our manufacturing facilities have been for the past ten years devoted exclusively to the production of fine Black Onyx Jewelry. We carry in stock the largest variety of articles made in our specialty, well made, finely finished, uniformly 14 karats, at medium and low prices.

WOGLOM & MILLER,
Office & Factory, 32 & 34 JOHN STREET,
NEW YORK.

W. C. GREENE & Co.
GOLDSMITHS.
MANUFACTURERS OF
RICH SETS IN TAPER WIRE CORAL

Factory 95 PINE ST. Providence, R. I.
Stone Cameo Amethyst Coral Cameo Engraved Enamel Brooches Sleeve Buttons Studs & C. EAR DROPS
New York Office 192 BROADWAY.
WM. C. GREENE R. W. GREENE GEO. D. BRIGGS

TO LET.

Floors 45x90 with Power, in New Building, cor. of York and Washington Streets, Brooklyn. Suitable for Jewelers and Silversmiths. Light on all sides. Conveniences for Burning and Grinding Sweeps. A night watchman in building. Location near terminus of bridge.

KETCHAM & McDOUGALL,
4 LIBERTY PLACE, N. Y.
MANUFACTURERS OF
GOLD AND SILVER THIMBLES,
And the Automatic Eye-Glass Holder.

ESTABLISHED 1859.

STURDY BROS. & CO.
MANUFACTURERS OF
Fine Rolled Plate Jewelry,
GRADUATED WIRE CORAL GOODS,
STERLING SILVER JEWELRY.

Bangles, Sleeve Buttons, Cuff Buttons, Baby Pins, Sets in Stone, Cameo, Enamel, Chased, and Polished, Drops and Knobs, Bar Pins, Children's Sets, Locketts, Studs, Charms, Etc.

Only Wholesale Dealers' Trade Solicited. ATTLEBORO, MASS.

THOS. M. GUILBERT & CO.,
SUCCESSORS TO
CARROW, DUBOSQ & Co.
908 Chestnut Street,
PHILADELPHIA.

We still Manufacture
and Repair
Strung Pearl Jewelry.

OUR SPECIALTY,
FLEXIBLE WOVEN BRACELETS.

B. A. BALLOU & CO.,
61 Peck St., Providence, R. I.
MANUFACTURERS OF
GOLD JEWELRY.



We call special attention to our PATENT FASTENING FOR EAR RINGS, which is free from the objections raised to ordinary ear wire or screw fastenings. They present a very neat and attractive appearance, are perfectly secure, and much more convenient than ordinary ear wires which always annoy the wearer by catching the hair, veil, or lace about the neck. These Goods are for Sale by all Wholesale Dealers.

Gold Studs, Small Chains for Eye-Glasses, Bracelets, Etc. a Specialty.

JAMES J. FISHER,
DEALER IN
WATCHMAKERS' and JEWELERS' MATERIALS,
Files, Tools, Silk Guards, Watch Glasses, Spectacles, Rolled Plate, Fire Gilt, Nickel and Silver Chain, Charms, &c.

No. 697 BROADWAY,
Corner Fourth Street, NEW YORK.
All kinds of Job Work for the Trade Promptly attended to.

The "Acme" French Clock Movement Support.
(Pat. Nov. 1st, 1881.)
This Support is adapted to the holding in position of any French Clock Movement while regulating or adjusting, and will be found very desirable on account of its simplicity of action and the small space it occupies. To be had of any respectable jobbing house, or sent, post paid, to any address, on receipt of 60 cents.



McCarty & Hurlburt,
WHOLESALE DEALERS IN
WALTHAM, ELGIN & ILLINOIS
WATCHES.
MANUFACTURERS OF
Jewelry, Gold Spectacles, Silver Thimbles, &c
131 North Second St.,
PHILADELPHIA, Pa.

ESTABLISHED 1853.

**C
L
O
C
K
S**

**BRANCH
STORE,
827
MARKET
STREET.**

B. J. COOKE'S SONS,
137 N. 3d Street, Philadelphia.
Catalogues and Price Lists furnished to the Trade only, on application.

BOOZ & CO.,

MANUFACTURERS OF

Watch Cases & Jewelry,

And Dealers in **DIAMONDS.**

108 South Eighth St., (2d Story) Philadelphia.

Samples of our goods sent on approval, when satisfactory reference is furnished
Old Gold & Silver Bought or Exchanged.
PARTICULAR ATTENTION PAID TO REPAIRING.



The ORIGINAL GOLD CROWN
FILLED RINGS.

For the past thirteen years we have manufactured as a specialty, the well known "CROWN GOLD FILLED RING," with the high standing of which the trade is already perfectly familiar. In consequence of the above fact, and in justice to ourselves, we feel it a duty to make the announcement to the trade that there are now being offered in the market several other makes of filled rings, each of which has a CROWN in some way connected with its STAMP.

We Manufacture for the Jobbing Trade Only.

McCALL & NEWMAN,
625 Arch Street, Philadelphia

O. W. BULLOCK,
SPRINGFIELD, MASS.,

MANUFACTURER OF

FINE NICKEL PLATED WATCH & JEWELING TOOLS,

Watch Keys and Light Metallic Goods.



SEND FOR NEW ILLUSTRATED CATALOGUE AND PRICE LIST.

HERPERS BROS.,

MANUFACTURERS OF

SETTINGS, &c.

18 CRAWFORD STREET, NEWARK, N. J.

Send for **PATTERNS** and **PRICES.**

Established 1848.

HENRY HARRISON,
66 NASSAU ST., NEW YORK,

MANUFACTURER OF

**Gold Bangles,
Bangle Rings,**

AND

Gold Flat Band and Buckle

BRACELETS,

Both Engraved and Enameled.

ALSO DEALER IN WATCHES AND JEWELRY.

IMPORTER OF THE BEST G. S. CHAIN.

B. W. KOOPMAN,

MANUFACTURER AND PATENTEE OF THE CELEBRATED

AUTOMATIC FIRE LIGHTING CLOCK.

The Ninth Wonder of the World.

Already Introduced on both sides of the OCEAN.

Sample of our New Style of Clock
sent to Jewelers at a Reduced Price.



For Circular, containing full particulars,
with Terms to Dealers, Address

KOOPMAN'S PATENT CLOCK WORKS, Terre Haute, Ind.
Refer to any Commercial Agency in U. S.

William T. Smith,
ASSAYER, REFINER AND SWEEP SMELTER.

ESTABLISHED IN 1855.

Cor. Blackstone & Hawkins Sts

PROVIDENCE, R. I.



PROVIDENCE, R. I., Feb. 1st, 1881.

To whom it may Concern:

We take pleasure in recommending Mr. WM. T. SMITH. He has done the whole of our Refining ever since he has been in business, and we have ever found him prompt in making returns, and always to our satisfaction.

D. WILCOX & CO.

JEWELRY AND WATCHES.

ROGERS' SILVERWARE.

MATERIALS AND TOOLS.

S. F. MYERS & CO.,
Manufacturers and Jobbers,
179 BROADWAY, NEW YORK.

ILLUSTRATED CATALOGUE FOR THE TRADE.

W. E. WHITE & CO.,
Manufacturing Jewelers.

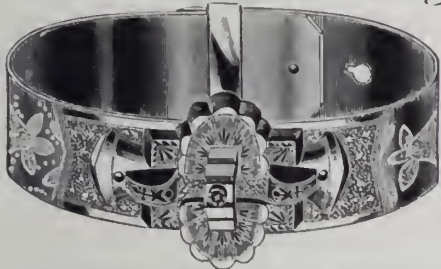

FINE
**ROLLED PLATE
GOODS.**

Bracelets---Engraved, Enamelled, Flat Band and Buckle.

Ladies' Goods—Lace Pins, Drops, Crosses, Sets, Collar Buttons, &c.

FOR SALE BY JOBBERS ONLY.

New York Office, 26 MAIDEN LANE, Corner Nassau Street.

Factory 54 Page St., Providence, R. I.

Represented by S. A. BALDWIN.

ALEX. MILNE,
Manufacturer of Stem-Winding Watch Crowns



ALSO GOLD AND SILVER THIMBLES.



19 Ward Street, NEWARK, N. J.

PFORZHEIMER, KELLER & CO.

MANUFACTURERS OF

FINE JEWELRY,

AND DEALERS IN

American and Swiss Watches,

No. 24 JOHN STREET,

NEW YORK.

I. PFORZHEIMER,
D. KELLER.

{I. B. ETINGER,
H. J. FINK.

Henry Fera,

Importer of Rough & Polished Diamonds,

DIAMOND CUTTING AND POLISHING WORKS:

21, 23, 25 Looijersgracht.

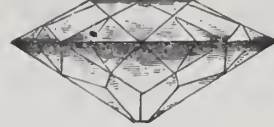

4 & 6 JOHN ST.,

Amsterdam, Holland.

New York.

Diamonds repaired and matched by some of the finest workmen in the world.

Diamond Bort and Powder always on hand.

ESTABLISHED 1850.

TRADE



MARK

PETER L. KRIDER,
MANUFACTURER OF
STERLING SILVERWARE

Medal and Diploma Awarded. &c. Striking Society
Medals in Gold, Silver or Bronze a Specialty.

Artisan Hall, 618 Chestnut St., Philadelphia.

BARNET BROS. & POWELL

Newark, N. J.,

— AND —

15 JOHN ST., NEW YORK.

R. & K.'S PATENT GAS FURNACES FOR MELTING, PLATING,
ENAMELING, ANNEALING, &c., &c.

Reichhelm & Koester,

Importers and Manufacturers of

Jewelers' Tools, Files, Materials, &c.,

Manufacturers of
Bristle Brushes of all kinds,
Cotton and Wool Buffs,
Felt Polishing Wheels,
Walrus Leather Polishing
Wheels,
Jewelers' Satin Finish and
Scratch Brushes,
Brass & Steel Wire Brushes
Jewelers' Standard Saw
Frames,
Plain & Fancy Draw Plates,
Improved Jewelers' Ingots,
R. & K.'s Jewelers' Combi-
nation Gas Burners.

80 Nassau St.

NEW YORK.

Importers of
French, English & German
Tools and Files,
Piercing Saws,
Renard & Vautier Gravers,
Steel and Brass Wires,
Vienna and Ruby Draw
Plates,
Alloying Copper Wire,
Felt, Walrus Leather,
Vienna Lime, Tripoli,
&c., &c., &c.

USE GOLD STOCK PLATED CHAINS

With Swivels Stamped

"R. F. S. & CO."

Every Chain Guaranteed by the Makers.

R. F. SIMMONS & CO.

ATTLEBORO FALLS, MASS.

Sold ONLY through Wholesale Houses.



HENRY ABBOTT,

7 MAIDEN LANE, NEW YORK.

MANUFACTURER

FOR SALE BY JOBBERS.

Patented November 18, 1873.

MORRISON'S Gold & Silver Solutions

For Electro-Plating Without a Battery.

Invaluable for Watchmakers and Jewelers. So simple that any one can use them.

Price, Gold Solution, - - \$3.00 Silver Solution, - - \$1.50

MANUFACTURED BY

ARTHUR B. MORRISON, Portland, Maine.

FOR SALE BY

Sussfeld, Lorsch & Co., New York; Henry Ginnel, New York; Cross & Beguelin, New York; Kearney & Swartchild, Chicago, Ill.; Louis A. Scherr & Co., Philadelphia, Pa.; Duhme & Co., Cincinnati, O.; Harwood Bros., A. Paul & Co., Palmer, Bachelder & Co. Boston, Mass., and material dealers generally.

BEWARE OF BASE IMITATIONS put up by unprincipled persons. None are genuine without the Trade Mark which consists of the letters A. B. M. in monogram and fac simile of Medal awarded by U. S. Centennial Commission.

JOSEPH STERN.

JACOB STERN.

SIMON STERN.

STERN & STERN,

Wholesale Dealers in

WATCHES & DIAMONDS

And Manufacturers of

GOLD JEWELRY,

6 MAIDEN LANE, NEW YORK.

AGENTS FOR THE CELEBRATED
MELVILLE & NEW BRIGHTON WATCHES.

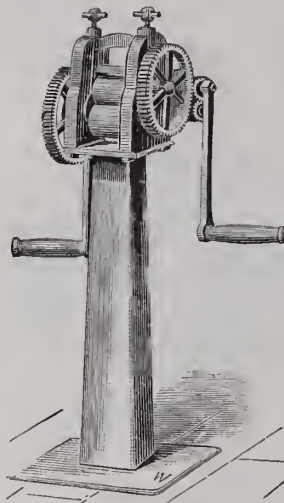

W. W. OLIVER,

MANUFACTURER OF

Hand and Power

Rolling Mills,

For Jewelers and Silversmiths.

The "Little Giant" Ring Bender

Hollow Spindle Lathes, Punching and Drop Presses, Polishing Heads, Dies, Metal Laps, Etc.

39 CLINTON STREET,

BUFFALO, NEW YORK.

Illustrated Price List mailed free upon application.

TRIER BROTHERS, IMPORTERS,

15 MAIDEN LANE, NEW YORK.

SPECIALTIES:

Bohemian Garnet, Whitby Jet, Steel and Amber Jewelry, Opera, Marine and Field Glasses, Telescopes, Pearl Oard Oases, Silk Guards, Etc.

Also a Complete Line of

GOLD AND GOLD PLATED JEWELRY.

FRESE'S PATENT ROLLER REMOVER

Patented April 10, 1877. Reissued November 16, 1880.

THE MOST CONVE-
NIENT TOOL FOR
THE PURPOSE.

PRICE, - \$2.50

FOR SALE BY ALL
DEALERS.

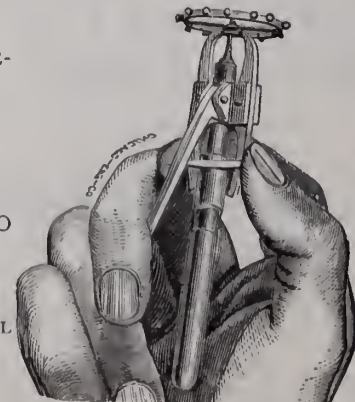

KEARNEY
&
SWARTCHILD

Chicago, Ill.

WHOLESALE
AGENTS.

TAKE NOTICE That my name and patent stamp is on the tool. Anyone offering a roller remover with a lever and jaws of any description that are adapted to receive and grasp a roller, infringes on my patent, and will be duly prosecuted.

B. FRESE, 99 Madison Street, Chicago.

WHEELER, PARSONS & HAYES,
 MANUFACTURERS OF
WATCH CASES, GOLD CHAINS & FINE JEWELRY

Importers of Diamonds and Manufacturers of Diamond Jewelry,
 And Dealers in American and Swiss Watches,
No. 2 MAIDEN LANE, NEW YORK.

ENOS RICHARDSON & CO.,

Manufacturers of
Gold Jewelry
 AND
CHAINS.



The Largest Stock
 of Gold Jewelry in the
 United States.

ESTABLISHED 1841.

Goods sent on Approval to
 Dealers in any part of the
 country upon receipt of order
 with satisfactory reference.

23 MAIDEN LANE, NEW YORK.

N. MATSON & CO.,
IMPORTING & WHOLESALE JEWELERS.

A full and complete Stock of the latest and most desirable styles.

ALL ORDERS PROMPTLY FILLED.

N. MATSON & CO.

166, 168, & 170 STATE STREET, CHICAGO, ILL.

Established 1828.

JACOB BENNETT & SON,
 Diamond Setters and Manufacturing Jewelers,
 No. 923 CHESTNUT STREET, PHILADELPHIA.

WE MANUFACTURE AND MAKE A SPECIALTY OF
 EVERY DESCRIPTION OF

DIAMOND MOUNTINGS,

SUPERIOR IN DESIGN AND WORKMANSHIP.



Dealers in

DIAMONDS

And all kinds of Precious Stones.

Of which we keep a Large Assortment Constantly on Hand.

Masonic Marks, Society and School Badges, Made to Order Only. Designs and Estimates Furnished.

PARTICULAR ATTENTION GIVEN TO ALL KINDS OF JOBBING.

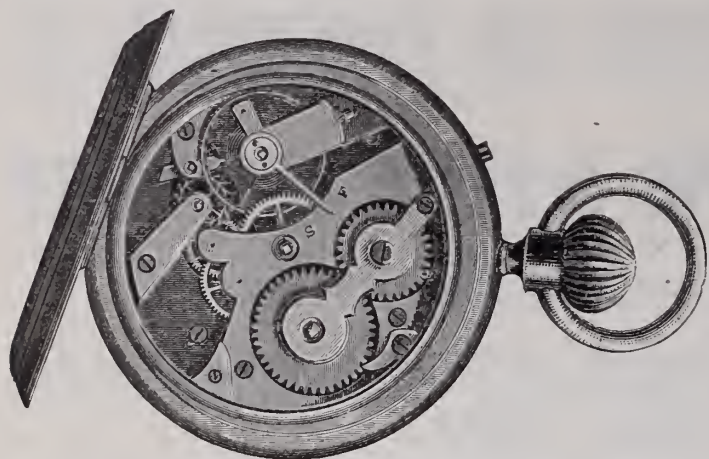

ESTABLISHED 1839:

HENRY GINNEL,

31 Maiden Lane, N.Y.

SOLE IMPORTER OF THE

PIONEER WATCH

Acknowledged by the Trade to be the best Watch for the money in the world.

They are for Sale by all the leading Houses throughout the land.

A. J. WARNER & CO.,

WHOLESALE JEWELERS,

309 Nicollet Avenue, Minneapolis, Minn.

We carry a Large and Elegant Stock of Jewelry, Watches, Cases, Etc., Etc.

North-western Agents of the WATERBURY CLOCK CO., and carry a Complete Line of their Goods.

OUR TRADE IS EXCLUSIVELY WITH THE JEWELERS.

WASHBURN'S PATENTS

SHUT OPEN

 SAFETY CATCH, Pat. Sept. 20, '81, Jan. 10, '82.

Safety Ear Fastening No. 1. Safety Ear Fastening No. 2.

 Patented May 10, 1881. Patented October 11, 1881.

Jointed Ear Wire and Bar between Cramp of Setting.

 Patented March 10, 1881.

ADOPTED AND IN USE BY
RANDEL, BAREMORE & BILLINGS,
 DIAMONDS,
 58 NASSAU STREET,
 NEW YORK.

Descriptive Circulars FURNISHED ON APPLICATION.

Address or Apply to
GEO. W. WASHBURN
 58 NASSAU ST.,
 NEW YORK.



ERRICO BROTHERS,

—IMPORTERS OF—

SILVER FILIGREE,

CORAL AND SHELL JEWELRY.

We call the SPECIAL ATTENTION of the Trade to the Latest Novelties in French and Italian Fancy Goods.

31 John Street, New York.

➤ **M. FOX & CO.,** ➤

Practical Lapidaries and Importers of

D I A M O N D S .

Rubies, Sapphires and Fancy Gems.

➤ **PEARLS, TURQUOISE, INTAGLIOS, ONYX, AMETHYST, ETC.** ➤

NO. 1 MAIDEN LANE, NEW YORK.



No. 1608.

Raised Initial in Diamonds
in Recessed Stone.

**SINNOCK & SHERRILL,
Seal and Stone Ring Manufacturers,**

Factory, Goldsmith Hall, Maple Place,
Green Street, Newark.

3 MAIDEN LANE, NEW YORK.

MANUFACTURE

Complete Lines in Cameo and Intaglio Rings; Amethyst, Plain and Incrusted; Garnet and Pearl, Turquoise and Pearl, and Turquoise and Diamond; Plain and Incrusted Topaz, Smoked Spanish, and Oriental. Also Sapphire and Diamond and Diamond Initial Rings both Raised and Incrusted.

SOLOMON, WEINBERG & CO.,
150 STATE STREET, CHICAGO, ILL.
JOBBER OF
American Gold and Silver Watches, Jewelry,
AND IMPORTERS OF ALL KINDS OF OPTICAL GOODS.

We have on hand the largest line of Opera, Field and Marine Glasses, Telescopes, Spectacles and Eye-Glasses to be found west of New York. We are headquarters for them as well as everything in the Jewelry line. Remember us when you need anything.

LEON JEANNE.

PAUL JEANNE

JEANNE BROTHERS

MANUFACTURERS OF

DIAMOND MOUNTINGS,

AND RICH JEWELRY.

NO. 1 MAIDEN LANE, NEW YORK

Designs Furnished and Estimates Given.

JEANNE BROS PAT. DIAMOND SETTINGS.

A PLATINUM SETTING WITH A GOLD SURFACE OUTSIDE

IN THIS WAY THE REFLECTION OF GOLD THROUGH THE DIAMOND IS ENTIRELY AVOIDED.

PAT. AUG. 15TH 1882



1028.



1026.



720.



1015.



1024.



1027.



1023.

→* FOR * SPRING * TRADE *←

HENRY C. HASKELL,

MAKER OF FINE GOLD JEWELRY.

No. 12 John St., New York.

Goods sent on approval to any part of the country, upon receipt of satisfactory references.

FINE DIAMOND, RUBY-SAPPHIRE RINGS,

PEARL AND TURQUOISE RINGS,

NOVELTIES IN SCARF PINS,

SEALS, LOCKETS, &C., &C.

Illustrated Plates of Designs for Portfolio sent only to Dealers upon request.

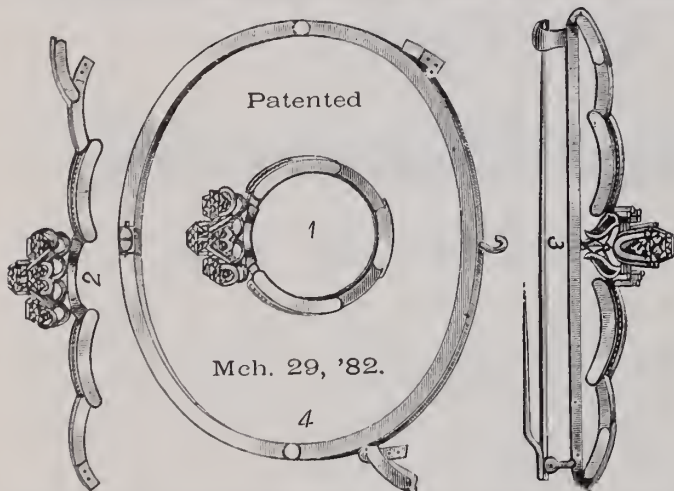

HELLER & BARDEL,

Manufacturers of

→DIAMOND * AND * PEARL * JEWELRY,←

No. 13 JOHN STREET, New York.

These Cuts represent a Novelty which we have introduced this season, viz.:

The Combination Ring, Lace Pin and Bracelet.

The advantages of this article of Jewelry will be readily appreciated, when taken into consideration that **One Piece of Jewelry** can be worn in three different forms.

Fig. 1 represents the Ring complete.

Fig. 2 represents the Ring open.

Fig. 3 represents the Lace Pin with Ring Attachment.

Fig. 4 represents the Bracelet to which Attachment can be made.

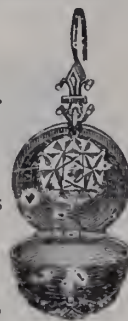

House Established 1837,

Successor to J. A. ABRY.

CHARLES LEO ABRY,

Importer and Manufacturer of all Grades of

SWISS WATCHES,

And dealer in Elgin, Springfield, Ill., and Lancaster Movements.

Specialties in Gilt, Nickered and Nickel Stem-Winding Movements, Ladies' Sizes, to Fit Elgin Cases.

IMPORTER OF THE FOLLOWING WELL-KNOWN SWISS WATCHES:

Geo. Mayor, A. Ames Droz, Chas. Estine, F. Richard, Huguenin Nardin and Ernest Duval, as well as all kinds of Watches for the Jobbing Trade, including Nickered, Open-Face and Hunting Stem-Winders, Anchors and Cylinders, 16, 18 and 19 lines. Silver Key and Stem-Winders, Hunting and Open Face, all sizes and qualities, from low to highest grades. Silver and Nickel 13 and 14 line Watches for Chatelaines, Gold, Silver, Nickel & Rolled Plate Chatelaines of good styles & designs always in stock.

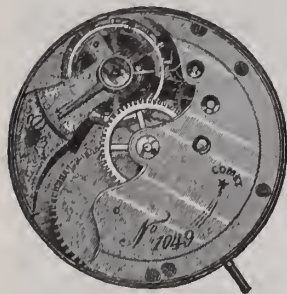

COMET.

SOLE IMPORTER.

Fits 8 Size Elgin Cases.

P. O. Box 611.

63 NASSAU STREET, NEW YORK.

Factory, Neuchatel, Switzerland.



A. BERNHARD & CO.
 MANUFACTURERS OF
DIAMOND & FINE JEWELRY
 ORNAMENTAL HAIRWORK

OFFICE & FACTORIES
 3, 4 & 5 FLOOR,
 P.O. BOX 111.

2
 Maiden Lane,
 NEW YORK.



WM. S. HEDGES & CO.,

IMPORTERS OF



COPYRIGHT SECURED. Entered According to Act of Congress in the year 1880, by WM. S. HEDGES & Co., in the Office of the Librarian of Congress, at Washington.

170 BROADWAY,

Corner Maiden Lane, New York.

CHOICE BRILLIANTS IN SINGLE STONES AND MATCHED PAIRS A SPECIALTY.

Fresh invoices of Goods in all Grades constantly arriving. Also, choice parcels of exceptionally Fine Gems ESPECIALLY Selected for critical purchasers. A full line of Mounted Goods, Artistically Designed.

GOODS SENT ON APPROVAL.

More Valuable Information for

The U. S. Mint Assay shows that Gold Case No. 8576, bought in Philadelphia for 18 karat, was below the quality stamped and paid for.

Stamped 18 Karat, Invoiced $53\frac{1}{2}$ dwts.

The buyer of this Case supposed that he was getting $53\frac{1}{2}$ dwts. of 18 karat gold, for which he paid \$42.80, instead of which he got $43\frac{1}{2}$ dwts. of $16\frac{1}{2}$ karat gold, worth \$32.19, and $8\frac{3}{4}$ dwts. of steel in Springs and Key Pipe, and $1\frac{3}{4}$ dwts. of brass in Crown, to which must be added the price paid for making.

The U. S. Mint Assay shows that Gold Case No. 6234, bought in New York for 14 karat gold, was below the quality stamped and paid for.

Stamped 14 Karat, Invoiced $40\frac{1}{2}$ dwts.

The buyer of this Case supposed that he was getting $40\frac{1}{2}$ dwts. of 14 karat gold, for which he paid \$25.92, instead of which he got 31 dwts. of $13\frac{1}{4}$ karat gold, worth \$18.91, and 8 dwts. of steel in Springs and Key Pipe, and 2 dwts. of brass in Crown, to which must be added the price paid for making.

The U. S. Mint Assay shows that Gold Case No. A7700, bought in New York for 14 karat, was below the quality stamped and paid for.

Stamped 14 Karat, Invoiced $42\frac{1}{4}$ dwts.

The buyer of this Case supposed that he was getting $42\frac{1}{4}$ dwts. of 14 karat gold, for which he paid \$27.04, instead of which he got 36 dwts. of $13\frac{1}{2}$ karat gold, worth \$22.32, and $5\frac{1}{4}$ dwts. of steel in Springs and Key Pipe, and 1 dwt. of steel in Crown, to which must be added the price paid for making.

Plump 14 Karat Gold is $583\frac{33}{100}$ Fine.

" 18 " " 750 "

By referring to the figures in opposite table and comparing them with the standards as shown above, the Buyer will see the difference between the quality as proven by assay and the actual value of the Gold furnished.

The above Assays were made at the U. S. Assay Office purpose, and it is proper to allow one-half of a karat for

Buyers of Gold Watch Cases.

The U. S. Mint Assay shows that Gold Case No. 15282, bought in San Francisco for 18 karat, was below the quality stamped and paid for.

The buyer of this Case supposed that he was getting 60½ dwts. of 18 karat gold, for which he paid \$48.40, instead of which he got 49⁸ dwts. of 15 karat gold, worth \$33.83, and 9 dwts. of steel in Springs and Key Pipe, and 1¾ dwts. of brass in Crown, to which must be added the price for making.

The U. S. Mint Assay shows that Gold Case No. 191233, bought in New York for 14 karat gold, was below the quality stamped and paid for.

The buyer of this Case supposed that he was getting 48½ dwts. of 14 karat gold, for which he paid \$31.04, instead of which he got 40¼ dwts. of 13 karat gold, worth \$24.15, and 7 dwts. of steel in Springs and Key Pipe, and 1¼ dwts. of brass in Crown, to which must be added the price paid for making.

Gold deposited at the U. S. Assay Office at New York.

DESCRIPTION.	GROSS WEIGHT.		FINENESS.	
	OUNCES.	DEC.	GOLD.	SILVER.
8576	690½
6234	554
15282	622½
191233	539
A7700	561½

Signed, J. F. WILDER, for Assayer.

in New York City. The entire Case was melted for the Solder, Joint Pins, etc.



Randel, Barmore & Billings,
Importers of
Diamonds
and Manufacturers of
Diamond Jewelry.

*58 Nassau Street,
8-29 Maiden Lane,
New York.*

*1 St. Andrews Street,
Holborn Circus,
London, E. C.*

ESTABLISHED 1859.

RINGS A SPECIALTY.

BRYANT & BENTLEY,

12 MAIDEN LANE, Up-Stairs, NEW YORK.

AMONG OUR LATEST PATTERNS OF FINE SOLID RINGS ARE



587



591



584



504



589



490

No. 587—Made in Topaz and Amethyst. No. 591—Cluster of Garnets, Doublets or Turquoise, with Pearls and Diamonds. No. 584—Cameo or Garnet with Pearls and Diamonds. No. 504—Misses' Turquoise Rings. Nos. 490 and 589—Represent two patterns only of our Engraved Band Rings.

We also continue to make a full line of our well known 16 K. HARD SOLDER RINGS.

Goods sent on approval to responsible parties.

Chapman's Patent Finger-Ring Measure.



PRICE, \$2.00.

DESCRIPTION.—The Sizes run from One to Thirteen, corresponding with U. S. Standard. By placing the finger in the circle at the top, as shown in cut, and drawing the small slide down the Dial or Indicator, it will give the exact size of the finger. It will remain at that size until relieved by a small thumb spring, which throws it back to Thirteen, or the largest size.

The Cut shows the exact size of a New, Novel Invention for taking the size of the finger, and does away with Ring Stick and Ring Sizes, and at same time corresponds with the Standard Ring Stick, being Neat and Well Finished for Jewelers' Use.

FOR SALE BY ALL JOBBERS.

The Trade Supplied by

GEO. WOLF & CO.,

Proprietors and Manufacturers,

LOUISVILLE, KY.

THEUERNER & CHURCH,
MANUFACTURERS OF FINE RINGS,

No. 9 MAIDEN LANE,

FACTORY, COR. MULBERRY & DURAND STS., NEWARK, N. J.

NEW YORK.

R. & L. FRIEDLANDER
264 BOWERY,

IMPORTERS OF

Watch Materials, Tools

AND OPTICAL GOODS,

And Wholesale Dealers in and Manufacturers of

Solid Gold and Plated Jewelry.

FACTORY, 50 BOND STREET.

Address Communications to 264 Bowery.

PRICES OF
Solid Gold
BANGLES.

No.	Per Doz.,	\$3.50
6,	"	1.75
7,	"	1.75
8,	"	3.50
9,	"	1.75
11,	"	3.50
13,	"	1.75
14,	"	1.75
21,	"	1.25
25,	"	1.25
26,	"	2.50
27,	"	2.50
28,	"	2.50

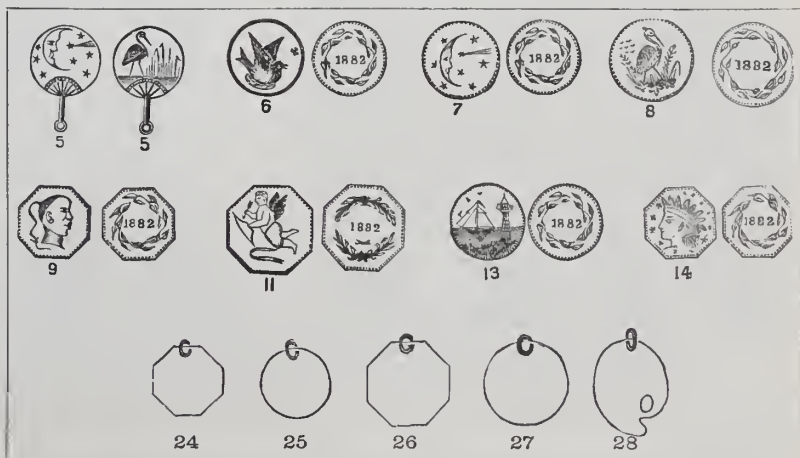

LUDWIG LEHMANN,

MANUFACTURER OF

JEWELERS' FINDINGS,

Paper Jewelry Boxes, Jewelers' Cards, Cotton of all Shades, a Rich Assortment of Cases in Plush, Velvet and Morocco.

Also Importer of the Celebrated Grass Bleached Tissue Paper, Mill 39.

Specialties:—Imitation Morocco Boxes and Cases, Plush and Satin Lined.

122 FULTON STREET, near Nassau, NEW YORK.

HOPKINS' PATENT IMPROVED PIVOTING CHUCK,

WITH PUMP CENTER.

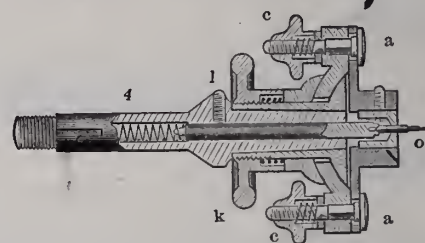
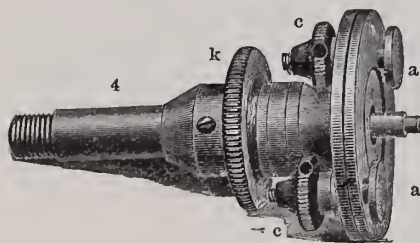

This Chuck, in accuracy of working, exceeds any other Chuck, either adjustable or self-centering, ever made, and is the only Chuck that, without the use of wax, will hold work to as perfect center and line as though held between dead centers.

HOPKINS WATCH TOOL CO.,

WALTHAM, MASS.

Send for full Descriptive Catalogue of our Manufactures.

ESTABLISHED 1810.

VACHERON & CONSTANTIN,

WATCH MANUFACTURERS,

GENEVA,

SWITZERLAND.

These celebrated Watches and Movements are adjusted to Heat, Cold and Position. Movements Fitting ready made Stem-winding, Open Face and Hunting Cases of Waltham and Elgin Sizes.

SOLE AGENT IN UNITED STATES AND CANADA,

CHAS. LEO ABRY,

P. O. BOX 611.

63 NASSAU STREET, NEW YORK.



S. W. HALE & CO.,

Successors to HALE & MULFORD,

MANUFACTURERS OF

FINE JEWELRY,

692 Broadway, New York.



E. AUG. NERESHEIMER
& Co
IMPORTERS
of
DIA MONDS
21 MAIDEN
LANE
NEW YORK

NO 66 SARPHATI STRAAT
AMSTERDAM HOLL.

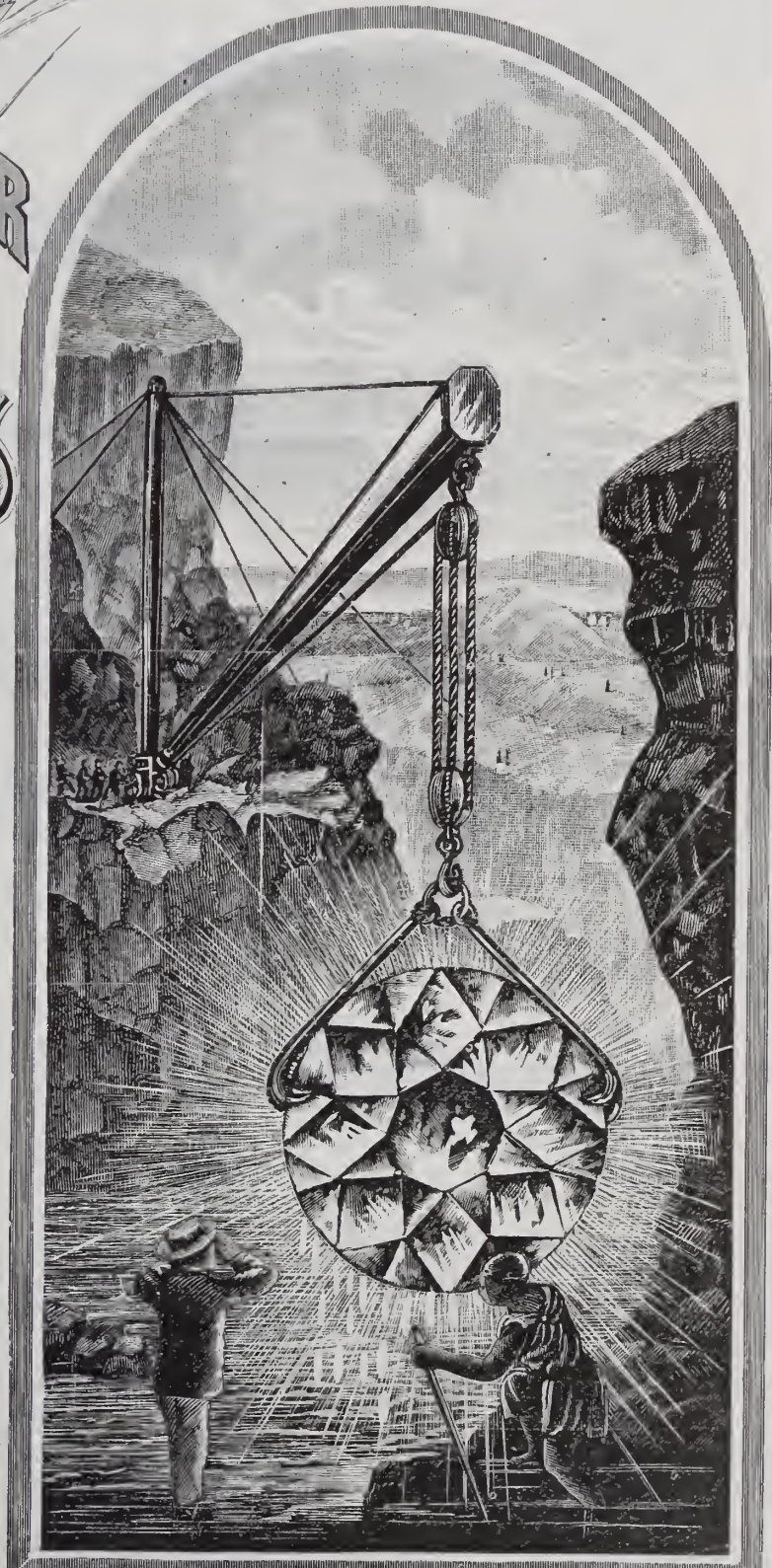

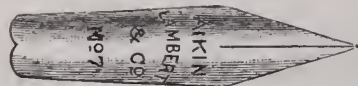

AIKIN, LAMBERT & CO.,
 23 MAIDEN LANE, NEW YORK.
 MANUFACTURERS OF
 GOLD PENS, PENCIL CASES, HOLDERS, PENCILS, TOOTH PICKS
 AND LATEST "NOVELTIES" IN PENCIL CHARMS.



NEW GOODS FOR SPRING TRADE.

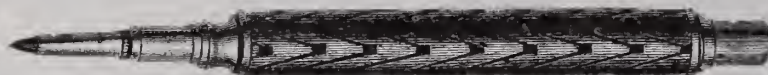

"GRAVITY" PENCIL.

In addition to our Large Assortment of Gold Pen and Pencil Goods, we offer this season many *New* and *Novel* Patterns, all of our *Exclusive* Manufacture and Sale.



Our Line of Richly *Ornamented Engraved* Holders in all styles, suitable for Presentation purposes, show many Patterns *New* to the Trade.



New Styles of Pencil Charms in *Solid* Gold, Silver and Rolled Plate.



Our Line in Tooth Picks embraces the *Latest* Designs in *Solid* Gold, Silver, Pearl, Celluloid (Fancy and Plain) and Plated.



Goods Sent on APPROVAL when desired.

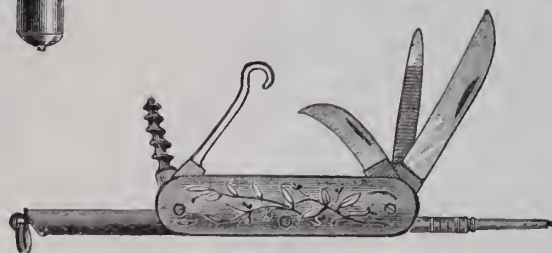

SEND FOR
Catalogue and Price List.



—:o ALSO IMPORTERS AND JOBBERS OF ALL GRADES OF o:—

WATCHES.

Including a Large Variety of *Desirable* Metal Cased Stem-Winders, and the *best* Low-Priced "Chronograph" Watch in the market.

Agents for *AGASSIZ* Movements fitting 8 and 16 Size Elgin Cases, and the *LONGINES* Movements fitting 18 Size Waltham Cases. Sole Agents for *PAUL BRETON* Celebrated Geneva Watches.

Jobbers of all kinds of *AMERICAN MOVEMENTS AND CASES*, including the Dueber and Keystone Silver Cases, and Boss' and Ladd's Filled Cases.

Manufacturers of *STONE RINGS*, all leading kinds, Band Rings, &c. Gold and Silver Thimbles, Plain, Chased, Octagon, &c. Bracelets, a large assortment in Gold and Plate. Gold and Plated Chains, Locketts, Seals, &c. A large variety of new and stylish Patterns in *GOLD* and *PLATED JEWELRY* are constantly being added to our stock. *Prompt attention to Orders and Repairs.*

JAS. C. AIKIN,
H. A. LAMBERT,
J. B. SHEA,
D. F. FOLEY.

Western Branch, 113 EAST MADISON STREET, CHICAGO, ILLS.

MATHEY BROS. & MATHEZ,**NO. 16 MAIDEN LANE.**

IMPORTERS OF ALL GRADES OF

Plain and Complicated Watches and Movements.

SOLE AGENTS FOR THE WELL-KNOWN

H. L. MATILE

Fine Watches of Astronomical Precision.



REPEATERS.



CHRONOGRAPHS.

The counsel of the Observatory of Neuchatel, Switzerland, have awarded Mr. H. L. Matile, of Locle,

THE GRAND PRIZE OF THE OBSERVATORY

for all his watches submitted for test, all having exceeded the required standard. This is the first diploma ever issued to any manufacturer by this Observatory. The first prize was also granted to Mr. Matile for movement No. 10,778 showing the closest rate during the rigid trials given by the Observatory.

RELIABLE COMPLICATED WATCHES,

In the production of which the finest watchmaking talent in Switzerland is employed, and the most perfect machinery known in the art of horology. These goods are made in conformity with a system of strict uniformity of parts, which insures regularity and absolute accuracy, while their workmanship and finish is unexcelled. Owing to our extraordinary facilities, we are enabled to furnish them at prices consistent with the character of the goods.

In order to facilitate the handling of our Stem-Winding Movements, we have adopted a standard of sizes to fit American Cases. Of these we have a complete line from the medium grade to the highest class goods of fine adjustment and precision. As all our Movements, complicated and plain, are perfectly uniform in quality according to their respective grades, we can furnish material for any parts that may be required, with the positive assurance of accurate interchangeability.

We have received for the Spring Trade a very fine stock of CHATELAINES, also Ladies' Watches, 12, 13, 14 and 15 Line, in Plain and Fancy Cases.

WATCHES DEMAGNETIZED.**Especial Attention Given to Demagnetizing Watches.**

In view of the great number of watches rendered useless by becoming magnetized, and the difficulty experienced by watchmakers in eradicating this mischievous element from the movement, we would state that we have a process which thoroughly destroys all traces of magnetism and restores the affected parts to their original condition.

Cases should always be sent with movement, as very frequently the lifting springs are also magnetized.

WE GUARANTEE A PERFECT CURE IN EVERY CASE.

TAYLOR & BROTHER,
676 BROADWAY, NEW YORK.
IMPORTERS OF
Diamonds and other Precious Stones,
Clocks, Bronzes and Fancy Goods,
 AND
MANUFACTURERS OF DIAMOND JEWELRY.



*Especial attention is directed to our Recent Invoices of FRENCH CLOCKS,
 Sold at EXTREMELY LOW PRICES.*

ORIGINAL PACKAGES OF DIAMONDS CONSTANTLY ARRIVING,

Falkenau Oppenheimer & Co.
Importers of
Diamonds



40 Maiden Lane N. Y.

Post Office Box 3314.



Our friends will please notice that we have removed
our Establishment to above address.



OPPENHEIMER BROS. & VEITH,
 WATCHES,
 DIAMONDS,
 JEWELRY.



We are the Manufacturers and Patentees of the Combination Slide, Pendant and Locket, and the Combination Necklacc, Lace Pin and Pendant.



We can furnish quite a variety of Styles, and are prepared to fill all Orders at once.

35 MAIDEN LANE, NEW YORK.

MARBLE CLOCKS.

In order to accommodate Wholesale Dealers who cannot select personally from our stock, we have prepared a Catalogue of some of the Better and More Striking Patterns from our large assortment—over **300** different styles—of

FRENCH MARBLE GONG CLOCKS.

This Catalogue is now ready and will be sent to the

JEWELRY AND CLOCK TRADE ONLY.

Dealers applying for it will confer a favor by sending their Business Card.

LE BOUTILLIER & CO.,

IMPORTERS AND JOBBERS,

3 UNION SQUARE,

NEW YORK.

LOUIS KAHN.

MOSES KAHN.

SAMUEL H. LEVY.

I. W. FRIEDMAN.

L. & M. KAHN,

IMPORTERS OF

Watches, Diamonds & Precious Stones,

10 MAIDEN LANE, NEW YORK.

11 Corrairie, Geneva, Switzerland.

17 Rue de Chateaudun, Paris.

WATCHES,*Stem and Key-Winding, from the Lowest Priced Nickel and Silver to the Finest Gold and Complicated.*

A Full Assortment of these Goods always in Stock.

DIAMONDS,*Loose and Mounted, in all Sizes and Qualities.**Gold, Silver, Nickel and Celluloid Chatelaines in Great Variety.***J. M. CHANDLER & CO.,**

—MANUFACTURERS OF THE—

PATENT EMBOSSED BRACELET.*These cuts represent examples of one of the many styles of our New Patent Embossed Bracelet.*

Chain Bracelets either in Gold or Plate are necessarily weak, as a small rivet is used to connect the links; when one rivet fails, the whole comes apart. The Embossed Bracelet is an exact imitation of a chain made from a solid piece of stock by a patent process, and while the goods are of the best quality, the price is much lower.

The stock from which these goods are made is plated in our factory, and we **GUARANTEE** each and every pair to wear and give satisfaction. They are adjustable and will fit any arm.

We will send Selection Packages of the Goods to Dealers on Approval.

ADDRESS ALL ORDERS TO

J. M. CHANDLER & CO.,

JOBBERS IN ALL KINDS OF

CLOCKS, WATCHES, JEWELRY, AND ALL KINDS OF TOOLS AND MATERIALS,

185 Superior Street, Cleveland. O.

T X E

E. HOWARD WATCH AND CLOCK CO.,

—MANUFACTURERS OF—

Fine Stem-Winding Watches,

**FINE REGULATORS, OFFICE CLOCKS, TOWER CLOCKS,
And Electric Watch Clocks.**



LADIES'
6 Size.

**STEM-WINDING
AND**



GENT'S
16 Size.

**Stem-Setting
Movements.**



GENT'S
18 Size.

114 TREMONT ST., BOSTON.

29 MAIDEN LANE, New York.

J. W. J. PIERSON, Agent.

CHARLES GLATZ,

MANUFACTURER OF

GOLD & SILVER WATCH CASES

A SPECIALTY OF

FULL WARRANTED 8 KARAT GOLD CASES,

Made in a Larger Variety than any other house, and Workmanship fully equal to the best in the Market.

JOBBER IN ALL AMERICAN MOVEMENTS.

We Call the Attention of the Trade to the Line of LOUIS XIV. Cases, in Gold and Silver, which we have Constantly on Hand.

10 MAIDEN LANE, N. Y. CITY.

EXCLUSIVELY FOR THE JOBBING TRADE.



TENTH AND CHESTNUT STREETS, PHILADELPHIA.

MORGAN & HEADLY,

MANUFACTURERS OF

GOLD, SILVER AND STEEL

EYE-GLASSES & SPECTACLES.

OUR TRADE GROWS Apace.

We are constantly improving our Patterns and Machinery, and Educating our Employees, thereby advancing the standard of our business.

The coming season will prove us to be still going ahead in our Special Line. With more extensive Stock and Facilities, and everything advanced except Prices, which are uniformly low, we invite a continuance of your patronage.

IMPORTERS OF DIAMONDS.

Keeping a full assortment, including matched pairs of fine quality, which we will send to the trade on memorandum, at low prices, on receipt of satisfactory reference.

MORGAN & HEADLY, Tenth and Chestnut Streets, Philadelphia.

ROGERS, SMITH & CO.,

MANUFACTURERS OF

ELECTRO GOLD

AND

Silver Plated

Ware.



SALESROOMS:

46 E. 14th Street,

UNION SQUARE, N. Y.

FOR THE TRADE ONLY.

FACTORY,

- - - -

MERIDEN, CONN.

FINISHED WATCH MATERIALS

For all Grades and Sizes of the Celebrated
 Longines and Agassiz Movements, can be
 obtained from all the Principal Jobbers
 and Watch Material Dealers throughout
 the country.

J. EUGENE ROBERT,

30 MAIDEN LANE, NEW YORK.

LONGINES,

AGASSIZ,

AND INTERCHANGEABLE PARTS.

ESTABLISHED 1844.

DENNISON MFG CO.,

BOSTON, NEW YORK, PHILADELPHIA, CHICAGO, CINCINNATI AND ST. LOUIS.

JEWELERS' FINDINGS.

PAPER JEWELRY BOXES IN ALL STYLES AND QUALITIES. IMITATION MOROCCO BOXES, SATIN LINED. TAGS, JEWELERS' CARDS, PINK AND WHITE COTTON, &c., &c.

MOROCCO CASES.

Manufacturing in our own Shops Every Description of Morocco, Plush and Velvet Jewelry and Silverware Cases in large quantities, we are enabled to sell lower than other goods of equal quality can be offered, and we carry in all our Stores FULL Stock of our whole line.

Catalogue on Application.

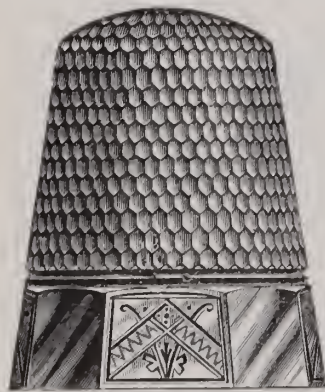

13 Maiden Lane,

NEW YORK.

FRANK S. KENNEDY,

Manufacturer and Wholesale Dealer in

JEWELRY

OF EVERY DESCRIPTION.



13 Maiden Lane,

NEW YORK.

In addition to my stock of Jewelry, which is complete in all lines of Gold, Silver and Roll Plate, I am now making a Full Assortment of

⚡: **THIMBLES**, :⚡

in Solid Silver, 10 karat and 14 karat Gold. These Thimbles are Superior in Finish to any now in the market, and are as near perfection as long practical experience can make them. Will send Samples if desired.

The Assortments of Jewelry I send on Memorandum for Special and Stock Orders have an increasingly high reputation.

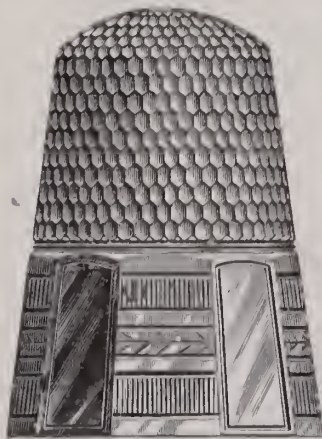

KREMENTZ & CO.

GOLDSMITHS,

No. 192 BROADWAY,

NEW YORK.

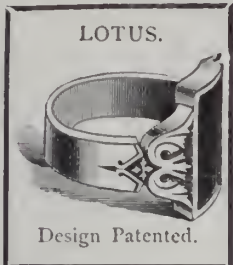

We offer for this Season's Trade a Full
Assortment of

DIAMOND, PEARL, ONYX, CAMEO & ROMAN GOLD JEWELRY

NOVELTIES IN LADIES' AND GENT'S RINGS.

ALSO A LARGE VARIETY OF DIAMOND MOUNTINGS,
ALL GOODS OF OUR OWN MANUFACTURE.

JOHN A. RILEY & CO.,

Nos. 7 and 9 Bond Street, New York,

Manufacturers of the PATENT SPRING BRACELETS,

Patented Oct. 25th, 1876; Nov. 12th, 1878; June 29th, 1880.
Reissued June 1st, 1880.

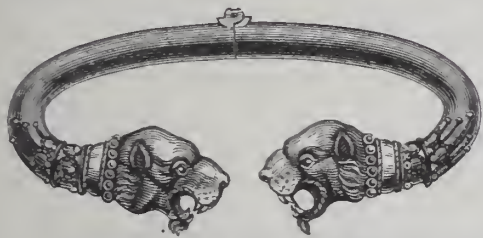

3251.

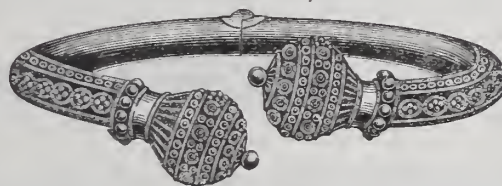

3432.

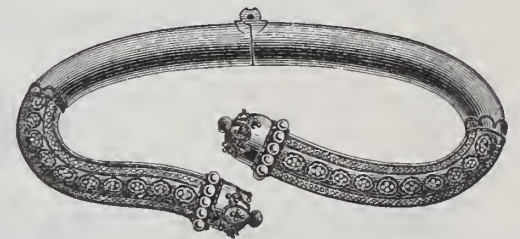

3418.

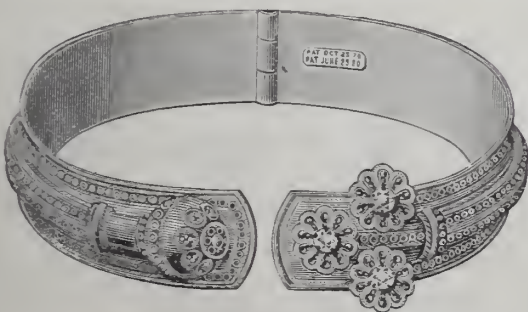

3755.

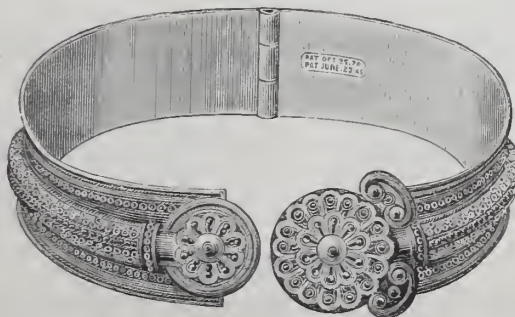

3753.

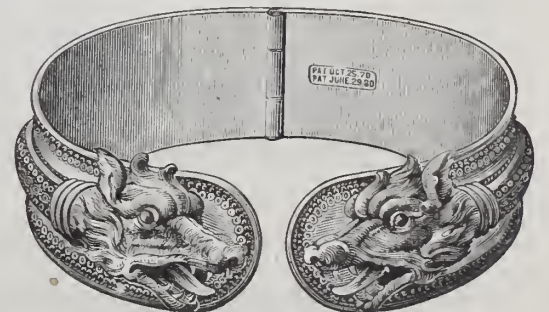

3694.

Rich Gold Jewelry, Novelties in Half Sets, Lace Pins, Scarf Pins, Ear Rings and Brooches, Engagement Padlock Bands and Hoop Ear Rings.

GOODS SENT ON MEMORANDUM TO RESPONSIBLE DEALERS.

ALL GOODS ARE OF OUR MANUFACTURE AND 14 KARAT FINE.

LOUIS AUDEMARS'



These Watches are made by the most Skilful Workmen in Switzerland, are Unexcelled in Workmanship and Finish, and have been accorded the

Highest Distinction of Merit

at the World's Expositions, and are universally acknowledged by the Most Eminent Makers to be the FINEST FINISHED MOVEMENTS MADE.



CHRONOGRAPHS AND CHRONOGRAPH SPLIT SECONDS

of an Improved Principle and unsurpassed for Accuracy and Precision.

MINUTE REPEATERS,

Minute Repeaters & Chronographs

and other Complicated and Intricate Movements.

All Movements of this Make are Cased in the Best Manner.



J. EUGENE ROBERT,

30 MAIDEN LANE,

NEW YORK.

1883

Announcement.

When (in 1879) we placed our improved BOSS' CASE upon the market, we thought we had the finest thing possible (and so it was at that time), but to-day (after a steady improvement of two years) we announce some grand improvements, and are able to offer as near a PERFECT Watch Case as can be made. These additions consist of A SOLID GOLD BOW, an ABSOLUTE DUST BAND, and JOINT BEARINGS of SOLID GOLD PLATE. Therefore all Cases made hereafter will have a Solid Gold Bow, and Joint Bearings of Solid Gold Plate, and all 16 size Hunting Cases a Dust Band (which will be adapted to other sizes as fast as possible)—and remember, that besides these new points, among the prominent features of the BOSS CASE, are the following: SOLID GOLD JOINTS, SOLID GOLD PLUGS, THE SAME CROWNS USED ON SOLID GOLD CASES, CLOSE-FITTING, ARTISTIC KNURLING OF CENTRES, ORNATE ENGRAVING, THE GOLD THE NATURAL COLOR, and NO GILDING (which is the bane and deception of other makes). We therefore christen it, JAMES Boss' PERFECT CASE.

Sincerely Yours,

HAGSTOZ & THORPE,

19TH AND BROWN STS.,

PHILADELPHIA, PA.

NEW YORK: 14 John Street.

CHICAGO: 67 Washington Street.

WHAT OTHERS SAY

—OF—

❖ T. A. WILLSON & CO.'S ❖

SYSTEM OF SPECTACLE MAKING.

* * * * "Permit me to compliment you on the **Excellency of Material and Superior Workmanship** of both Optical Part and Frames." * *

*F. A. P. Barnard, Pres. Columbia College,
New York City.*

* * * "Indeed, for **Accuracy and Beauty** of Finish of both **Glasses and Frames**, I have not seen your Workmanship surpassed and seldom equaled."

*C. S. Fenner, M. D.,
Author of "Vision—its Optical Defects," Louisville, Ky.*

* * * * "In the methods of constructing the Frames are secured the advantages of **Simplicity, Economy of Material, Elasticity and Strength.**"

Report of Juries, Centennial Commission, 1876.

* * * "The General Workmanship is **excellent**,—awarded **Silver Medal.**"

*Report of Committee on awards,
Franklin Institute, Phila.*

PARTS ALL INTERCHANGE,

LENSES, SCREWS, TEMPLES, &c.

All Spectacle Frames Have the Patent Compensating Temple Joint.

ADDRESS

ALBERT BERGER & CO.,

47 MAIDEN LANE,

NEW YORK.

Nos. 179 and 155 have the largest sale of any Spectacle in the U. S.

ASK YOUR JOBBER FOR THEM.

BIRCH'S PATENT WATCH KEYS.



2.-POCKET KEY.
(Brass.)



3.-POCKET KEY.
(Nickel Plated.)



4.-POCKET KEY.
(Nickel Plated, Hexagon Shell.)



5.-POCKET KEY.
(Heavy Rolled Gold Plate Mountings.)



6.-CELLULOID MOUNTED KEY.
(With Heavy Rolled Gold Plate Tips.)



12.-POCKET KEY.
(Heavy Rolled Gold Plate Mountings, Plain.)



13.-POCKET KEY.
(Sterling Silver Mountings, Plain.)



14.-POCKET KEY.
(Sterling Silver Mountings, Engine Turned.)



15.-POCKET KEY.
(Extra Heavy Rolled Gold Plate Mountings, 18 K., Plain.)



16.-POCKET KEY.
(Extra Heavy Rolled Gold Plate Mountings, 18 K., Engraved.)



17.-POCKET KEY.
(14 Karat Gold Mountings, Plain.)



18.-POCKET KEY.
(14 Karat Gold Mountings, Engraved.)



19.-POCKET KEY.
(Nickel Plated, with Heavy Rolled Gold Plate Ring and Push Pin.)



20.-POCKET KEY.
(Nickel Plated, with Black Wood Handle)



29.-POCKET KEY, CELLULOID M'T'G.
(Imitation Tortoise Shell, with Extra Heavy Rolled Gold Plate Tips, 18 Karat.)



21.-POCKET KEY.
(Brass.)



22.-POCKET KEY.
(Nickel Plated.)



23.-POCKET KEY.
(Nickel Plated, Hexagon Shell.)



24.-POCKET KEY.
(Same as No. 23, but with Fire Gilt Swivel and Ring.)

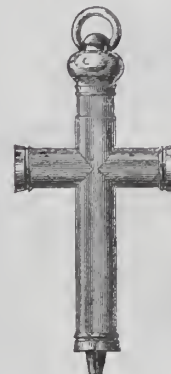

25.-CROSS KEY.
(Nickel Plated, with Heavy Rolled Gold Plate Tips.
Also in Heavy Rolled Gold Plate, No. 26)



36.-POCKET KEY.
(Sterling Silver Mountings, Plain.)



27.-CHARM KEY.
(Nickel Plated.)

Also in Heavy Rolled Gold Plate, No. 28

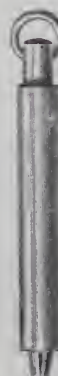

31.-POCKET KEY.
(14 K. Gold Mountings, Plain.)



32.-POCKET KEY.
(14 K. Gold Mountings, Engraved.)



33.-POCKET KEY.
(Extra Heavy Rolled Gold Plate Mountings, 18 K. Plain.)



34.-POCKET KEY.
(Extra Heavy Rolled Gold Plate Mountings, 18 K. Engraved.)



35.-POCKET KEY, CELLULOID MOUNTINGS.
(Imitation Malachite, with Extra Heavy Rolled Gold Plate Tips, 18 K.)



37.-POCKET KEY.
(Sterling Silver Mountings, Engine Turned.)



7.-BENCH KEY. (Brass Handle.)

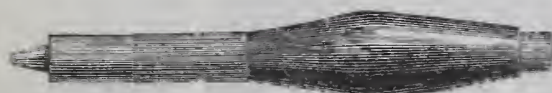

8.-SHORT WOOD HANDLE KEY.
(Nickel Plated, for Bench or Pocket Use.)

MADE IN

37 Different Patterns



9.-LONG WOOD HANDLE BENCH KEY.
(Nickel Plated.)

For Sale by the Jobbing Trade Generally. Circulars on Application,

J. S. BIRCH & CO.,

38 DEY STREET,

NEW YORK.

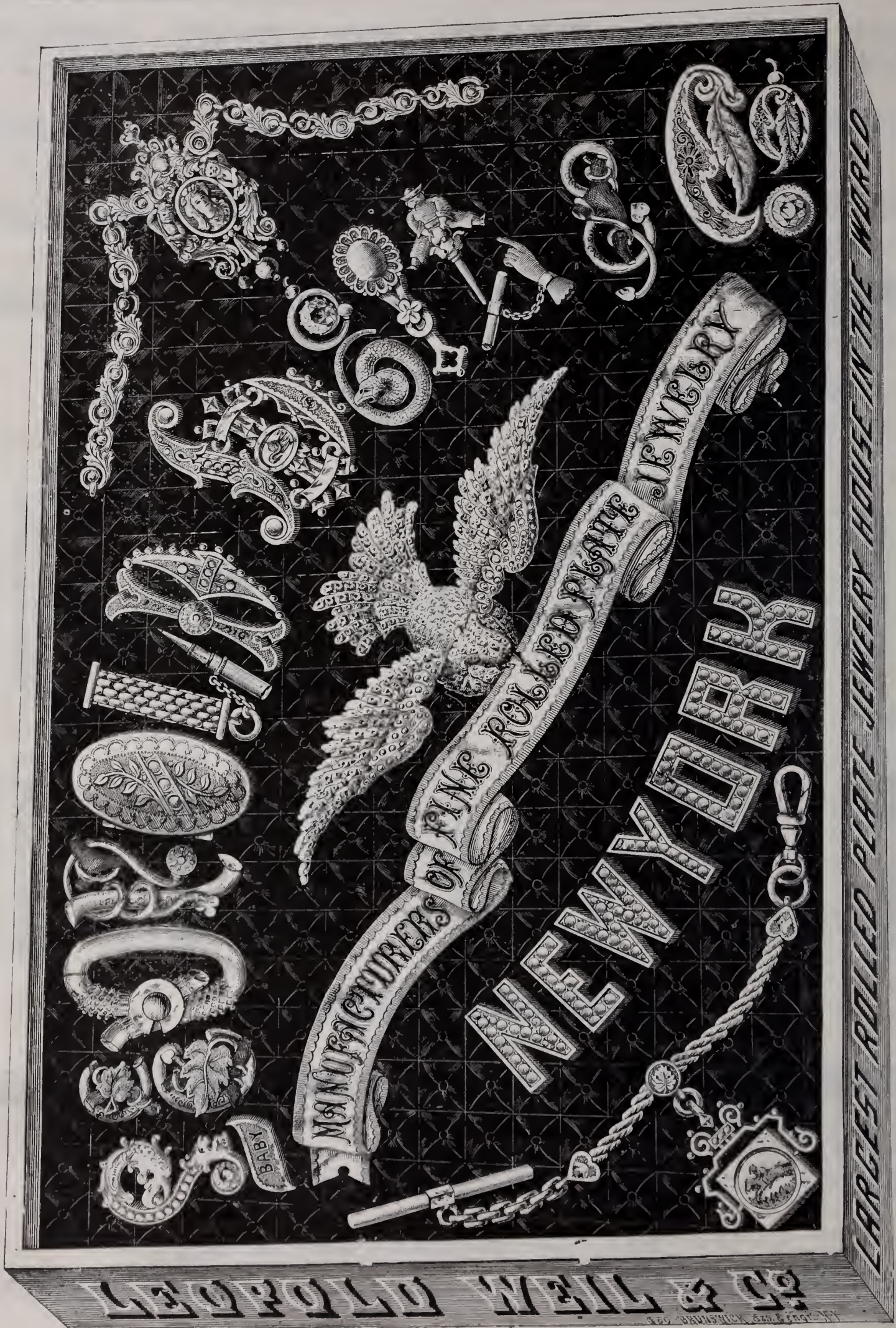

Copyright Secured.

LEOPOLD WEILL & Co



1380

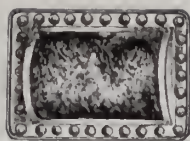

1162

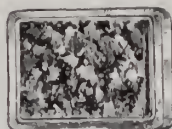

1687



93



1476



0027



864

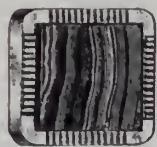

1206

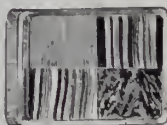

1479



0041



1234



0024



1420



1369



1239

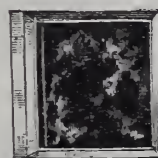

1321



1235



1340



017



93

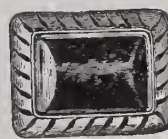

02

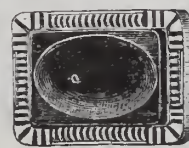

1182



634

THE

ACME LEVER BUTTON



OPEN.



CLOSED.



OPEN.



OPEN.



CLOSED.



CLOSED.



1257



1582



0025

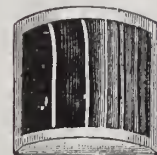

1003



020C



869



1437



1269

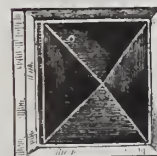

1502

Always was, is now, ever shall be
THE MOST CONVENIENT,
STRONG, RELIABLE and PERFECT SLEEVE BUTTON MADE

It Overcomes
ALL TROUBLE WITH STIFF CUFFS.

ASK YOUR JEWELER FOR THE
ACME LEVER SLEEVE AND COLLAR BUTTON,
AND TAKE NO OTHER.

For Sale by all Jobbers of Jewelry.



GEO. H. RICHARDS, JR.,
 383 WASHINGTON STREET,

BOSTON, MASS., U. S. A.



AMERICAN MOVEMENTS AND CASES A SPECIALTY.

We Guarantee to have ALL GRADES in Stock.

MOVEMENTS.

WALTHAM. SPRINGFIELD, ILLS. HAMPDEN.
 ELGIN. HOWARD.

→: **CASES.** :←

GOLD	*FILLED*	*SILVER*
WALTHAM.	"BOSS."	WALTHAM.
DUEBER.	CROWN.	DUEBER.
BROOKLYN.	LADD.	FAHYS.
G. H. R., Jr.		KEYSTONE.

Watches. Jewelry and Silver Plated Ware. Rogers & Bro.'s Flat Ware.
 HOLLOW AND FLAT WARE SOLD AT MANUFACTURERS' DISCOUNTS.

Our Stock is positively the Largest, Finest and Best Assorted of any Jobbing House in the Country. All Orders Promptly Executed.

GEO. H. RICHARDS, Jr., 383 Washington Street, Boston, Mass.

"The Waterbury." The New "Series B,"

With FULL DIAL and SOLID PLATES.

NEW SERIES B.

Bezel Off,

Showing Index Plate and Regulator.



NEW SERIES B.
Solid Plates and Full Dial.

In this new SOLID PLATE movement the position of the regulator has been changed; it will be found projecting beyond the plate, immediately under the bezel. The FULL DIAL enables the position of the hands to be readily seen.

The danger of injuring the Hair Spring in regulating is obviated in this new movement.

SERIES A.—Open Dial, Skeleton Plates, - - \$48.00 per doz.

SERIES B.—Full Dial, Solid Plates, - - - 48.00 "

Discount to the Trade.

We can supply either Pattern as ordered.

WATERBURY WATCH CO.,

WATERBURY, CONN.

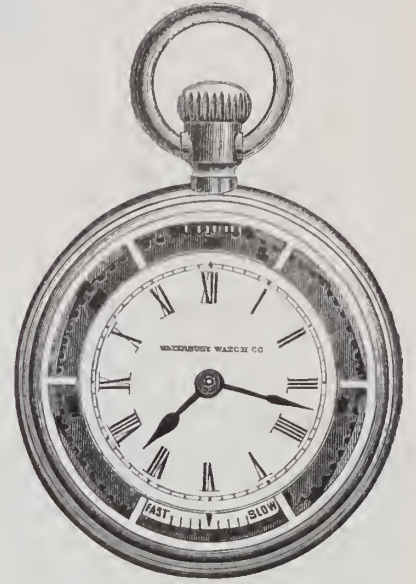

NEW YORK OFFICE, 4 MAIDEN LANE.

GEO. MERRITT, GENERAL SELLING AGENT,

To whom all Orders and Correspondence as to Prices and Terms should be addressed.

FOR SALE BY DEALERS GENERALLY.

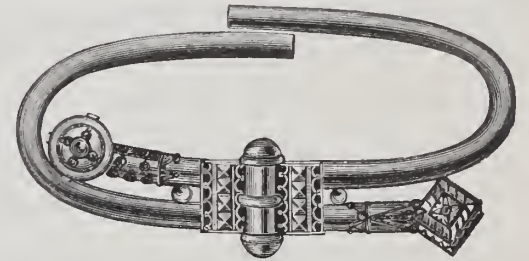
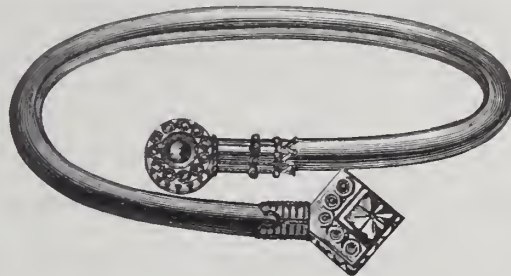
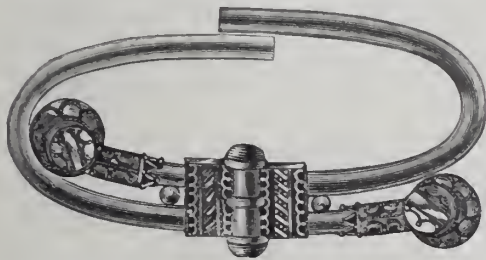

ELLISON & VESTER'S

PATENT

BAND AND BANGLE FINE ROLLED PLATE

BRACELETS,

For Sale by Every Jobber.

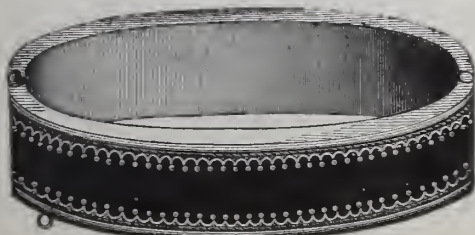





H. MUHR'S SONS,

PHILADELPHIA.



Important Announcement.

We have signalized the Opening of the New Year by making an

IMPORTANT REDUCTION

IN THE PRICE OF

CROWN FILLED CASES

In connection with this step, we take pleasure in announcing to the Trade that we have recently acquired ENTIRE CONTROL OF THE FACTORY, AND ARE NOW CONDUCTING THE PRODUCTION OF THE FILLED CASES UNDER OUR IMMEDIATE SUPERVISION, which fact enables us to offer the Improved Crown at better value than any Filled Case ever before placed upon the market.

The gold contained in Crown Cases, which are now being turned out under our supervision, IS FULLY EQUAL TO THAT OF ANY FILLED CASE ON THE MARKET.

This fact can be attested to the satisfaction of any dealer, who will go to the trouble of having one of these cases assayed, with one of corresponding size and style of ANY OTHER MAKE.

The United States Mint, at Philadelphia, will make a complete assay for the sum of one dollar each, and we will return a new case to the dealer in place of the one of our make destroyed, upon the receipt of the Assay Certificates and the gold contained in the Crown Case assayed.

Solid Gold Joints. Solid Gold Plugs.

CROWNS SAME AS USED IN SOLID GOLD CASES.

GOLD the Natural Color, absolutely no GILDING.

New York Office:

1½ MAIDEN LANE.

Chicago Office:

137 STATE STREET.



IMPROVED CROWN FILLED CASE.



Raised Gold Ornamentation.

SOLID

RAISED GOLD

ORNAMENTATION.



Raised Gold Ornamentation.

This feature, in connection with FILLED CASES, is entirely new; the Improved Crown, thus far, being the ONLY Filled Gold Case upon which this unique and attractive style of embellishment has ever been SUCCESSFULLY and ARTISTICALLY applied. Several new designs have recently been added; others will be announced soon.

On our regular line of ENGRAVED CASES we offer the Largest Variety of Original, Beautiful and Artistically Executed Designs ever presented to the Trade.

SOLD BY ALL LEADING JOBBERS.

H. MUHR'S SONS,
PHILADELPHIA.



Raised Gold Ornamentation.

NEW YORK OFFICE,
1½ Maiden Lane.

CHICAGO OFFICE,
137 State Street.



Raised Gold Ornamentation.

STANDARD WATCH CO.

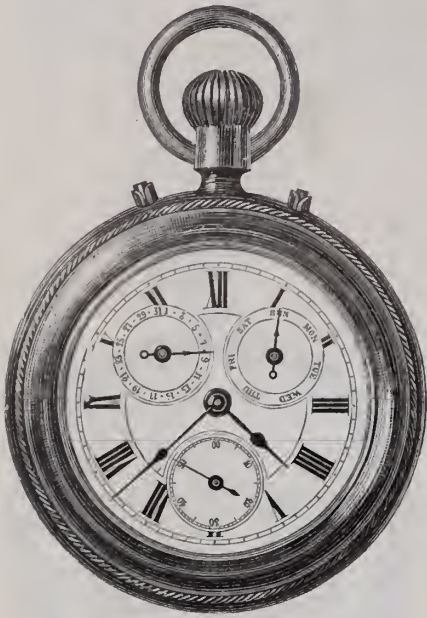

STANDARD CALENDAR

"STANDARD CALENDAR."

20 Line, Open Face, in Nickel and Silver, showing the date and day of the week, Full Jeweled, Finished Movement. The Latest Novelty offered.



"THE YALE."

18 Size, will fit Waltham Cases.



"THE JUNO."

Ladies' 8 Size, Full Jeweled, fits Waltham Cases.



"STANDARD."

8 Size, Full Jeweled, Ladies. Fits Waltham Cases.

REGISTERED.



"STANDARD."

Nickel, 17, 19 and 20 Line. Lever, Full Jeweled.

Max Freund & Co., Sole Agents, 8 Maiden Lane, New York.

All practical men who critically examine these Cases acknowledge this Process of Manufacture to be far superior to all others in all important features which constitute the Best Watch Case.

LADD PATENT

STIFFENED

GOLD WATCH CASES.

Sold by the Leading Jobbing Watch and Jewelry Houses at the Manufacturers' Wholesale Prices.



Design No. 588, in Flat.



Design No. 591, in Oval.



Design No. 593, in Flat.

THE STANDARD SINCE 1867.
FOR BEAUTY OF DESIGN AND ORNAMENTATION.
FOR STRENGTH OF FRAME AND COVERS. FOR SUPERIOR WORKMANSHIP.
FOR SATISFACTION THEY HAVE GIVEN IN WEAR AND DURABILITY.



Established
1841.



JOHN HOLLAND,

19 and 21 WEST 4th STREET,

CINCINNATI, OHIO.

Manufacturer of All Styles of Best Quality

GOLD PENS, PENCIL CASES, FINE PEN HOLDERS, GOLD TOOTH PICKS, &c.

A Large Variety of New Designs in Staples and Novelties.



Received the Award "For Great Elasticity and General Excellence of Gold Pens," at Phila. Ex., '76.

Catalogues mailed free. Handsome show cases loaned for display of goods.

STANDARD DUST-PROOF WATCH KEYS.

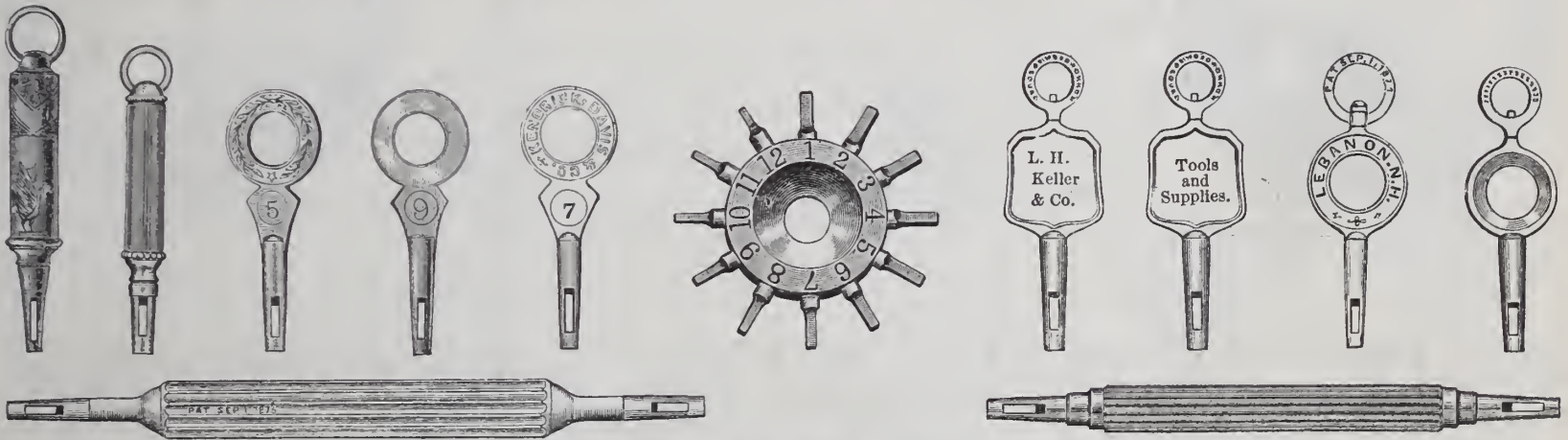

FOR SALE BY



THE TRADE.

KENDRICK, DAVIS & CO.

Sole Owners and Manufacturers, Lebanon, N. H.

ILLUSTRATED CATALOGUE AND PRICE LIST SENT ON APPLICATION.



GILES, BRO. & CO.
 Wholesale,
 Importing and
 Manufacturing
 JEWELERS,
 Cor. State & Washington Sts.,
 CHICAGO, ILLS.

Complete Illustrated Catalogue Furnished the
 Trade upon Application.

H. H. HEINRICH & CO.,

12 JOHN STREET, N. Y.

Sole Agents for the

Karl Zimmerman's Watch.

This Watch is an English Fusee Stem-Winder, with Index to show when it is wound up.

Having attached to it all the latest improvements in furtherance of close time-keeping, we are able to offer a Watch which cannot be excelled by any other in the market.

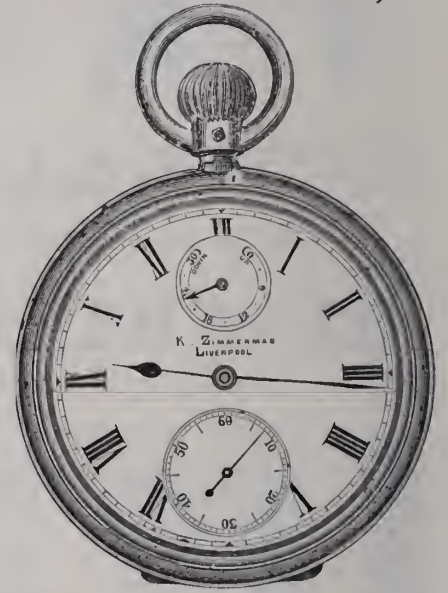

ESTABLISHED 1869.

THE JEWELERS' CIRCULAR AND HOROLOGICAL REVIEW,

THE RECOGNIZED ORGAN OF THE TRADE.

SUBSCRIPTION TO ALL PARTS OF THE UNITED STATES AND CANADA, \$2.00 PER ANNUM.

1883.



The XIV Volume of "THE JEWELERS' CIRCULAR AND HOROLOGICAL REVIEW" begins with the FEBRUARY ISSUE, and will surpass in interest all previous Volumes.

THE Olin Adjustable Chuck.

CONVENIENT, DURABLE, EFFICIENT.
THE ONLY CHUCK THAT ADJUSTS THE SPLIT CHUCK.

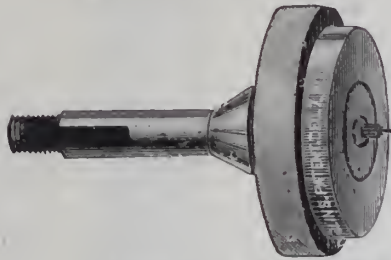

Emphatically THE chuck for accurate watch-work. Made of the finest steel and nickel plated. Can be applied to any watch-makers' lathe in use. Fitted free of charge. No chuck has ever been offered to the trade that so fully meets all the requirements as the OLIN.

Every wheel, pinion or staff in a watch is easily and quickly brought to a perfect center, and held true and firm.

Every One Warranted as Represented.

PRICES.

- Chuck complete, with combination for wheel chuck, nickel plated, with five split chucks, all in neat turned wood box, \$15.00
- Wheel chuck, put up the same way, 8.00
- Additional parts to make up complete chuck, 7.00
- Extra split chucks of any number, each, 1.00

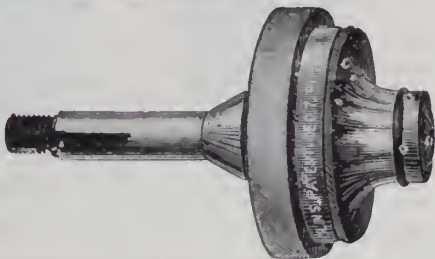

Our Split Chucks are all Tempered and Ground True.

Orders for Chucks to be fitted to American Lathes must be accompanied by a Split Chuck to fit by. If for Swiss Lathe, send the Lathe and Pulley Spindle.

Parties having Second Hand Lathes cheap, will find it to their advantage to address

THE OLIN CHUCK CO.,

MASON, MICH., U. S. A.

HUTCHISON & HUESTIS,
SOLID GOLD
RING MAKERS

SETTING PATENTED

FOR JOBBING TRADE

NEW YORK OFFICE, 196 BROADWAY.

FACTORY, 185 EDDY ST., PROVIDENCE, R.I.

WM. M. FISHER & CO.

Sole Manufacturers of the

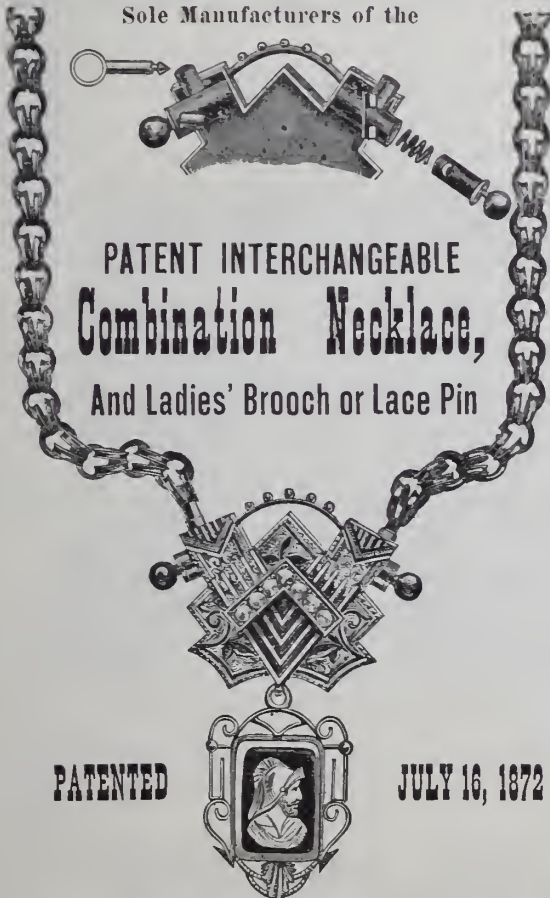

PATENT INTERCHANGEABLE
Combination Necklace,
And Ladies' Brooch or Lace Pin

GOLD
AND
SILVER
CHAINS,
—:—
Gold Chain
TRIMMINGS.
—:—

Complete
Assortment of

14-k.

Ribbon Fobs.

PATENTED

JULY 16, 1872

FOR SALE BY THE LEADING JOBBERS

The Burbank Manufacturing Company

Manufacturers of GOLD & SILVER



GOLD
SILVER,
STEEL,
RUBBER,
And SHELL,

Thimbles,



EYE GLASS
Self Adjusting.

SPECTACLES AND EYE-GLASSES



OF ALL DESCRIPTIONS.

SOLID GOLD RINGS

Office, 14 MAIDEN LANE, NEW YORK.

Manufactory, Springfield, Mass.

PETER B. SIMONS & CO.,

MANUFACTURERS AND IMPORTERS OF

FINE JEWELRY,

GOLD CHAIN,

Gold and Silver Thimbles, Canes, Sets, Etc.,

FOR THE TRADE ONLY.

No. 120 SUTTER STREET,
SAN FRANCISCO.

FACTORY:
611 & 613 SANSOM STREET,
PHILADELPHIA.

SALESROOM:
120 SUTTER STREET,
SAN FRANCISCO.

DEALERS IN AMERICAN AND IMPORTED

❖ GOLD ❖ AND ❖ SILVER ❖ WATCHES. ❖

KEY
Patented Jan. 25,
1881.

TAG
Patented Jan. 25,
1881.

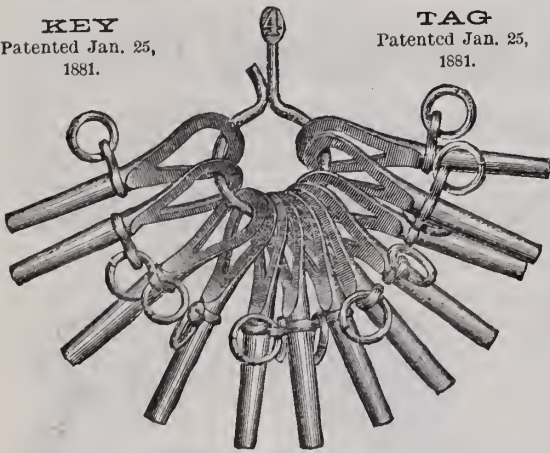

A. N. CLARK
PLAINVILLE,
CONN.,

Manufacturer of

Watch Case Springs, Watchmakers' & Jewelers' Bench Tools,
CROSBY'S JEWELING TOOLS, &c.

STOP IMPORTING KEYS!

For Low Price Key Use the

New Style Loop Key.



A plain Steel Key of good appearance, and excellent quality. It will not wear the pocket. It has a swivel, and is much better made than the imported plain steel or iron keys.

PRICE PER GROSS, FINE NICKEL FINISH, \$2.25
Postage, 10 Cents Per Gross Additional.

This Key is good and cheap enough to become universal. Send business card for illustrated price list. Enclose three cent stamp for sample key.

SOLD BY JOBBERS IN WATCH MATERIALS AND NOTIONS.

A. N. CLARK, Plainville, Conn.

PATENT CANE CASE.

Certain parties having infringed on our Patent for this most desirable Case, we now give notice that they can hereafter only be procured from us with safety.

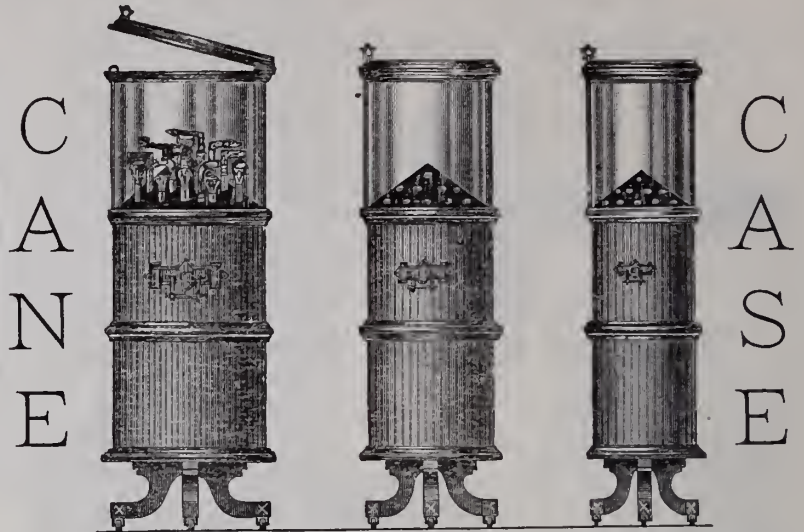

GOLD, SILVER and COPPER HEAD CANES in New Designs and Applied Work, in Greater Variety than can be found elsewhere.

SIMONS, BRO. & CO.,

611 & 613 Sansom St., PHILADELPHIA.

MANUFACTURERS OF

Cane Heads, Gold Chain, Bracelets, Thimbles and Fine Jewelry.

SWISS AUTOMATIC CLOCK PICTURES

Representing Various Pastoral Scenes and Landscapes with Animated Domestic Animals, Etc.

A Most Desirable and Attractive Picture for a Jewelry Store Window.



This cut represents the Automatic Clock Picture without the frame. They are framed in ornamental Gilt Frames and finished in various oil colors, resembling in appearance an oil painting. By winding the mechanical part the figures all move and the clock keeps correct time.

Size 21x25, \$21.60. Size 15x18, \$15.00. Net Cash

L. & M. KAHN,
SOLE IMPORTERS,

No. 10 MAIDEN LANE, NEW YORK.

ANNOUNCEMENT!

We desire to announce to the trade in general that we have REMOVED from 18 JOHN STREET to

NO. 9 MAIDEN LANE,

which we have fitted up with a view to our greater convenience and the better Display of Goods.

KELLER & UNTERMAYER, 9 MAIDEN LANE.

FOR SALE BY ALL JOBBERS.

FOR SALE BY ALL JOBBERS.

FOR SALE BY ALL JOBBERS.

THE P. O. D.
ROLLED GOLD

Vest Chain, Charm and Key.

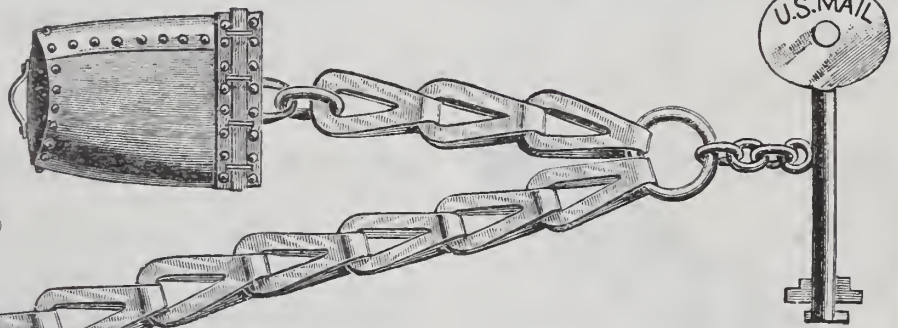

The Post Office Department Chain, Charm and Key is
Covered by Letters Patent,

And I hereby warn all manufacturers against manufacturing
the same.

TO THE TRADE

The above Chain is manufactured of Fine Rolled Plate, every link hand-
burnished and every chain warranted to give satisfaction.

C. W. LITTLE,

Patentee,

324 & 326 FIFTEENTH ST.,

DENVER, COLORADO.

FOR SALE BY ALL JOBBERS.

NEW YORK OPTICAL CO.,
Manufacturers of all kinds of
Spectacle Lenses, Spectacles,
—Eye-Glasses—
AND
SPECTACLE AND EYE-GLASS CASES.
OFFICE AND SALESROOM:
No. 43 MAIDEN LANE, N. Y.
FACORIES: BROOKLYN, N. Y.

BOYCE & WAINWRIGHT,
Manufacturing Jewelers
SOLID GOLD RINGS A SPECIALTY.
Our BAND RING Specialties for PRICE,
QUALITY and FINISH are not equaled by
any in the Trade.
383 Washington St., Room 26,
E. J. BOYCE.
W. H. WAINWRIGHT. **Boston, Mass.**

M. A. LOWENSTEIN,
IMPORTER OF
DIAMONDS,
PEARLS, PRECIOUS STONES & JEWELRY,
182 BROADWAY,
Cor. John Street, **NEW YORK.**

H. M. RAYNOR
No. 25 Bond St.,
New York.
PLATINUM WIRE
AND PLATE
FOR JEWELERS.
Scrap Purchased.



HENRY LEFORT,
Stem-Winding Watch Crown Manufacturer,
Crowns and Pushers in gold, all sizes, quality and color,
made to order. Silver crowns and pushers always on hand.
60 Arlington Street,
Corner William Street,
NEWARK, N. J.

JACOB STRAUSS,
WATCHES & JEWELRY
AT WHOLESALE.
18 JOHN STREET, NEW YORK.
Rings and Rolled Plated Chains
A SPECIALTY.

J. B. LAURENCOT,
IMPORTER OF
WATCH GLASSES,
Optical and Fancy Goods
French Clocks, Musical Boxes, &c.
No. 33 MAIDEN LANE.
5 Rue D'Enghen, PARIS. Box 2954, P. O. NEW YORK.

W. H. LUDEMAN,
No. 75 & 77 Nassau Street,
NEW YORK.
FINE AND COMPLICATED
WATCHES
Of every description repaired and regulated.
Stem Winding and Escape Wheels
Cut and finished to order with accuracy
and promptness.

J. J. COHN,
IMPORTER OF
—WHITBY JET—
MANUFACTURER OF
Gold & Rolled Plate Jewelry,
Bracelets, Charms & Locketts a Specialty
12 MAIDEN LANE, N. Y.
Goods Sent on Selection if Satisfactory References are
Given.

H. HOREND,
15 Maiden Lane, New York.
PUBLISHERS' AGENT
For Foreign Industrial and Art Publications concerning
watch and clock making and kindred arts. English,
German and French Periodicals. M. Grossman's and
other well known author's Horological works. M.
Grossmann's Fine Measuring Instruments based upon
the metric system, and his celebrated Models of
Escapements.
Price Lists on Application.

L. SAUTER.
1 MAIDEN LANE,
Manufacturer of
Fine and Diamond Jewelry
AS
Rings, Studs, Buttons, Scarf Pins, Etc.
Hair Jewelry in all its branches.
Jobbing of every description promptly attended to.

JOHN D. LENNON,
142 Fulton Street,
NEW YORK,
Manufacturing Jeweler,
Masonic Pins, Rings & Charms,
School, Athletic, Fine
Presentation Medals,
—AND—
JEWELS OF EVERY DESCRIPTION
Designs furnished free upon application.



HIBBARD G. GILL,
GOLD AND SILVER
Watch Case Manufacturer,
Dealer in Watches,
American Watch Movements Always on Hand.
618 Chestnut Street,
Fifth Floor. PHILADELPHIA.

HENRY TROEMNER,
710 Market Street,
PHILADELPHIA.
Manufacturer of Fine Gold Scales,
DIAMOND SCALES,
Bullion Balances and
Weights, in use at all the
U. S. Mints and Assay
Offices.
PRICED CATALOGUE ON APPLICATION.

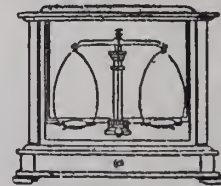

JNO. F. LUTHER,
MANUFACTURER OF
Masonic Jewelry.
79 Nassau Street, N. Y.
Illustrated Catalogue sent on application.

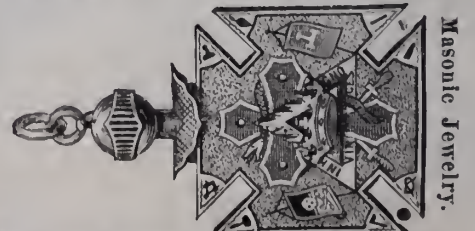

ESTABLISHED 1862.

A. LESSER & SON,
 Watchmakers' and Jewelers' Supply Depot,
 The Largest Jobbing House in Central New York!
 Elgin, Waltham, Springfield & Hampden MOVEMENTS.
GOLD AND SILVER CASES.
 A WELL-SELECTED STOCK OF FINE JEWELRY
 The Largest MATERIAL HOUSE Between New York and Chicago.
 We solicit the legitimate "Jewelers' Trade Only."
 Goods on approval require satisfactory reference
72 South Salina St., SYRACUSE, N. Y.

THEO. LESPERANCE,
 No. 1 Maiden Lane, (with Julien Gallet),
NEW YORK,
WATCHMAKER AND WHEEL CUTTER
 ALSO STONING NICKEL MOVEMENTS
 FOR THE TRADE.

Altering Watches from Key to Stem-Wind
 a Specialty. Also, Importer of Diamond Hands.

C. KNAPP,
 Manufacturer of
**Superior Band
 and Children's
 Stone & Fancy
 RINGS**
 And Enameled Goods,
**41 Maiden Lane,
 NEW YORK.**



Solid Gold Rings a Specialty.
WM. H. ELY,
SOLID GOLD RINGS,
 MANUFACTURER.
 Viz., Plain, Chased, Engraved, Enameled,
 Engine Turned, Shield and Scale. All
 qualities guaranteed. Orders
 Promptly Executed.
58 Nassau Street, New York.



C. B. WILKINSON,
 Manufacturing Jeweler,
8 JOHN ST., N. Y.
 Medals, Badges and
 Masonic Jewelry
A SPECIALTY.
 Designs furnished free
 upon application.

HESS & SCHLIESSER,
 IMPORTERS OF
DIAMONDS AND JEWELRY.

SPECIALTIES:
 Fine Novelties in French Goods, Gold and
 Blue Enameled Locketts, Charms
 and Crosses.
25 Maiden Lane, New York.

WM. RAWLINGS, JR.,
 Manufacturing Jeweler,
 FACTORY:
913 Arch Street, Phila.

FINE GOLD RINGS A SPECIALTY.

Goods sent on approval to any part of the
 country upon receipt of satisfactory reference.

THE JEWELER'S BOAT.



OSGOOD FOLDING CANVAS BOAT
 Is the boat to buy; you can fold it up and carry it in your buggy,
 or on your back; it is light, safe, and strong; it rows so easily,
 you can't blister your hands, or unset it without considerable
 effort; the best portable or sportsmen's boat made in the world.
SATISFACTION GUARANTEED. Send for Illustrated Circular,
 giving full particulars and references. Manufactured by
N. A. OSGOOD, Battle Creek, Mich.,
 DEALER IN—
Fine Jewelry, Diamonds & Sportsmen's Goods.



Print Your Own Cards,
 &c. Press \$3.
 Large sizes for circulars, &c., \$8 to \$90.
 For pleasure, money making, young or old.
 Everything easy; printed instructions. Send
 2 stamps for Catalogue of Presses, Type,
 Cards, &c. to the factory.
Kelsey & Co., Meriden, Conn.

H. WUNDOEHL,
GOLD & SILVER REFINER,
 Assayer and Sweep Smelter,
21 JOHN ST.,
 Bet. Broadway & Nassau St., **NEW YORK.**

The highest price paid for Gold, Silver and Platinum.
 Fine Gold, Silver and Copper always on hand.

JANDORF & BRO.,
Watches and Jewelry,

196 BROADWAY,
 Bet. John & Fulton Sts., **NEW YORK.**

We Publish No Price Lists.

WATCHMAN'S IMPROVED TIME DETECTORS,
 With Safety Lock Attachment.

U. S. Patents 1875-76-77-80-81-82.

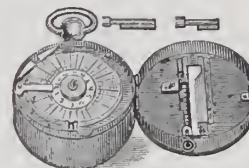

This instrument is supplied
 with 12 different keys for 12
 stations. It contains all
 Modern Improvements
 against the old style, and is
 the only
COMPLETE INSTRUMENT.

E. IMHAUSER,
 P. O. Box 2875. **212 Broadway, N. Y.**

THE ACME OF PERFECTION.



**ALWAYS have on
 Sale this Celebrated
 Match Case.**

It has No Equal on the
 Globe. No Lady's or Gentle-
 man's outfit complete with-
 out one.
Solid Nickel Silver, 50c
Bronze Silver (equal
to Coin Silver, - - - - - 75c
 PATD 1879, '80, & '81. Samples or Goods sent pre-
 paid to any part of the world
 on receipt of price. **F. S. DANGERFIELD,**
Sole Mfr., Auburn, N. Y., U. S. A.
 Goods sold by First-Class Dealers everywhere.

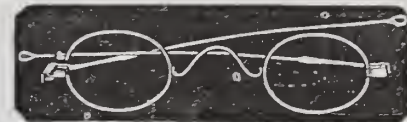

GEO. W. DUBOIS, F. N. NAUMAN.
GEO. W. DUBOIS & CO.,

IMPORTERS OF
WATCHES and OPTICAL GOODS,

GOLD, SILVER AND STEEL
SPECTACLES & EYE-GLASSES.

36 Maiden Lane, N. Y.

Regular styles of Gold, Silver and Steel
SPECTACLES.

Gold, Steel, Rubber and Tortoise Shell
EYE-GLASSES

Constantly in Stock.

All qualities kept in single numbers

Spectacle and Eye-Glass Cases of all
 Styles and qualities, lettered to order
 with names of Dealers.

Particular attention given to orders by
 mail. Send for price list and enclose
 business card.

SUCCESSING
FRANCIS DUBOIS & CO., Watches.
GEO. W. DUBOIS, Optical Goods.

Spencer Optical Man'fg Co.

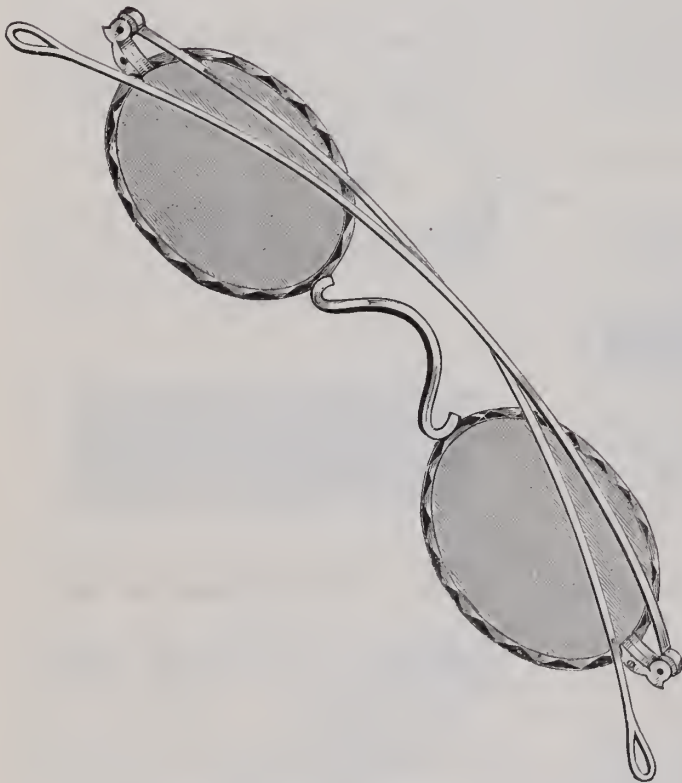
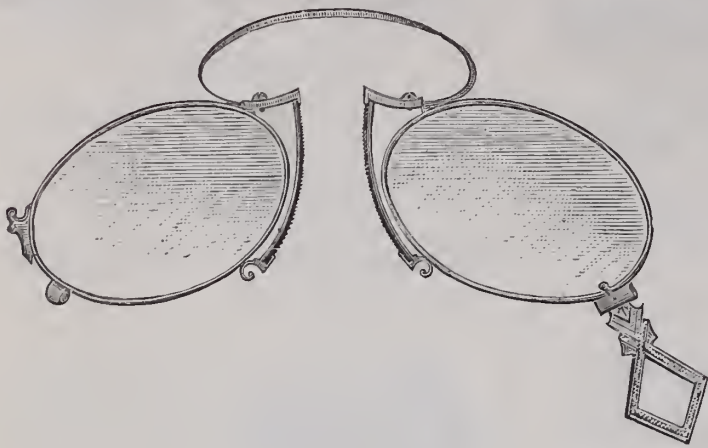

Gold Spectacles and Eye-Glasses

Are a Specialty with the SPENCER OPTICAL MAN'FG CO. They make a larger variety than any other house in the world. All of their Gold Spectacles have extra strengthening pieces at Nose-piece and End-pieces, also Gold Eye-Glasses at handles; this makes them much more durable than formerly. We have many new and original styles for the Holiday trade. All of our frames are made the Standard interchanging size. Our new Catalogue will be issued Dec. 1st, and will be sent free of charge on application and receipt of business card.

SPENCER OPTICAL M'F'G CO.,

Makers of all kinds of Spectacles and Eye-Glasses,

13 MAIDEN LANE, NEW YORK.

Established 1853.

L. H. KELLER & CO.

Successors to G. A. HUGUENIN,

IMPORTERS OF

WATCHMAKERS' and JEWELERS'

TOOLS AND MATERIALS.

GENERAL AGENTS FOR

The Philadelphia Watch Company,

— AND —

American Watch Tool Co.,

MANUFACTURERS OF

THE WHITCOMB LATHE.

SOLE AGENTS IN THE UNITED STATES FOR THE SALE OF

LUTZ'S

CELEBRATED ROLL HARDENED HAIR SPRINGS, MOEBIUS OIL

For Chronometers, Watches, Clocks, Telegraph Instruments and all other delicate machinery. Made from Pure Refined Neatsfoot Oil, and Warranted to Excel anything in the market as a Lubricator. SAMPLES GRATIS.

OUR OWN GRADUATED

AND JURGENSEN RECOILING MAINSPRINGS, pronounced by all experts Superior to all. Sold in Separate Strengths or Force.

Extra Fine Pinions cut from Solid Steel Wire. Gauged Hole Jewels of First-class Workmanship. A Full Line of Materials, for the PATEK, PHILIPPE & CO. GENEVA WATCHES, and all other Celebrated Makers.

THE BOLEY LATHES AND TOOLS,

Celebrated for their Practical, Substantial and Workmanlike Construction, Superior Design and Finish.

Our aim is to furnish nothing but First-class Serviceable Goods, especially manufactured for the Consumer, and not solely for the Market, like the cheap trash advertised in highly illustrated catalogues with which the country is flooded.

TREATISE ON MODERN HOROLOGY IN THEORY AND PRACTICE. By M. CLAUDIUS SAUNIER, Ex-Director of the School of Horology at Macon, France; Knight of the Legion of Honor, etc.; Hon. Sec. to the Paris Society of Horologists. Translated from the French by JULIEN TRIPPLIN, Besançon Watch Manufacturer, and EDWARD RIGG, M. A., Assayer in the Royal Mint, London.

This Work comprises 832 large octavo pages, with 78 wood cuts and 21 colored double-page copper-plate engravings. Bound in half calf, with an appropriate and handsome ornament in gold on front cover.

Price, \$15.00.

THE WATCHMAKER'S HAND BOOK. By the same author and translators. Intended as a companion to the Treatise. Bound in cloth.

PRICE, \$4.00.

64 Nassau Street,

NEAR MAIDEN LANE,

NEW YORK.

L. H. KELLER,
EDWARD HUNZIKER, }
F. J. BOESSE.

We do not publish Price Lists.

SPECIAL NOTICES.

REPAIRS for the trade undertaken and sound workmanship guaranteed by W. F. A. Woodcock, Cumberland, Md. Hull and Moseley tools, etc.

OFFICE TO LET—Half of front office, suitable for jeweler or watchmaker, good light. Apply to John A. Riley & Co., Nos. 7 and 9 Bond Street, N. Y. City.

FOR SALE—Volumes 1 to 4 inclusive of "American Horological Review," bound in half morocco, for years 1870 to 1874. Address C., care Jewelers' Circular.

FIRST-CLASS watchmaker, who can also engrave and act as salesman, can obtain a permanent situation and good wages by addressing "M," care Jewelers' Circular.

FOR SALE—J. Stark No. 3 combination lathe and jewel setting rest, \$95. Also other small watch lathes for pivoting. J. M. Graham, 250 S. Main Street, Providence, R. I.

WATCHMAKER and engraver wanted for a northwestern city. Good opportunity and wages given. Must be first-class. Apply to Bryant & Bentley, 12 Maiden Lane, N. Y.

TOOLS, stock and fixtures of an old established manufacturing jewelry concern for sale, together with three years' lease of store. Apply to Sillocks & Cooley, 4 Maiden Lane, N. Y.

WANTED—A first-class watchmaker and engraver for one of the largest jewelry stores in Wisconsin. Steady employment to the right party. Address Oshkosh, care Jewelers' Circular.

THOROUGH No. 1 watchmaker and engraver desires to make arrangements with some good house April 1, 1883. Correspondence solicited. Address "Adjusted," care Jewelers' Circular.

TO MANUFACTURING JEWELERS—To let, a fine loft, with 12 windows, 22x45, with or without steam power, suitable for manufacturing jewelers. F. Demmert & Son, 6 Maiden Lane, N. Y.

WANTED—A first-class watchmaker and engraver who is prompt and reliable. A permanent situation and good wages paid to the proper person. Address F. P. Loomis & Co., Ottumwa, Iowa.

WANTED—Situation by a young man of over 4 years' experience at the bench, of good morals, and strictly temperate. Can give satisfactory references. Address E. B. Wade, Fergusonville N. Y.

BRAZILIAN merchant wishes to receive catalogues of all American manufacturers, and specimens of Yankee notions free of cost. Direct to Francisco Jose Martins, Relojoaria Garantida, "Para Brazil."

SITUATION wanted by a young man under a first-class watchmaker to complete learning trade, has had 3 years' experience. Can give good references. Address Sidney Smith, Lafayette Sussex Co., New Jersey.

AN EXCELLENT chance is offered to a good jeweler or watchmaker with some capital. Location in best part of the city. Established trade over 30 years. For particulars apply to A. B. C., Jewelers' Circular.

FOR SALE—In a thriving, growing town of Jersey, stock and fixtures of jewelry store. No other jewelry store in town, good run of bench work. Small capital required. Address J. J. Cohn, 12 Maiden Lane, N. Y.

WANTED—An engagement by an experienced watchmaker. Has had 13 years' experience at the bench. Best of reference. Address W., P. O. Box 204, Superior City, Wis.; or, L. Trickey, West Hoboken, New Jersey.

FOR SALE—Jewelry store, stock, tools and fixtures, paying stand, no competition, new store. Will rent with privilege of buying store if parties wish, low rent. Stock, tools, etc., \$1,000 cash. Isaac W. Reed, Sharon, Conn.

AN EXCELLENT opportunity for a young man who has had two or three years' experience at the bench, to finish his trade. A good situation and moderate salary will be given. Address Oshkosh, care Jewelers' Circular.

MOSELEY & CO., Elgin, Ill., manufacturers of the "Moseley" Lathe, with full line of fixtures and attachments. Designed especially for the watchmaker and repairer. Combining accuracy, durability, convenience and style.

WANTED—A situation as an apprentice to a competent watchmaker, city or country. Have had 2 years' experience in repairing clocks and jewelry. Satisfactory references given. Address W. C. B., Lock Box 7, Danbury, Conn.

A YOUNG MAN who has learned the watch trade and wishes to improve, will find such a situation at a first-class watchmaker's. One that can engrave and repair jewelry is preferred. Address Nebraska, care Jewelers' Circular.

SITUATION wanted by a young man to complete his trade. Has had some experience at the bench, is sober and industrious, and can furnish satisfactory references. Would prefer either Chicago or New York. Address F. P. Allen, Louisville, Ga.

WANTED—Situation under a competent watchmaker and engraver to finish trade, by a young man of 3½ years' experience at bench and as salesman, can do letter engraving. Best of reference furnished. Address at once, G. W. C., Ashland, Ills., Box 1616.

FOR \$5.00 I will change to a stem wind and set, any American 18 size movement, except (Springfield, Mass.) This is a new patent device and is in no way inferior to any stem wind ever made. Send for circular to Reeves & Co., room 8, No. 713 Sansom street, Phila.

WANTED—Position in jewelry, diamond or plated ware house, either for office or road, by a young man with six years' experience on the Lane, and possessing a thorough knowledge of the business. Best of references given. Address Jewelry, care Jewelers' Circular.

FOR SALE—One-half interest in the leading jewelry store in the best town in the West. Established 11 years, business good, competition light. The best chance in the West for a man with four to five thousand capital. Loss of sight and health cause of selling. Address W. C. Burdick, Pueblo, Colo.

EUGENE C. HOLBROOK, formerly with the Whiting Manufacturing Co., now with John T. Vansant & Co., 611 Sansom Street, Philadelphia, is now carrying for the new house a full and handsome line of sterling silverware. Mr. Holbrook will be pleased to have his old friends remember him.

FOR SALE—A good paying jewelry business, established nine years, town of 5,000 population, near Chicago, two railroads, live town. Fresh stock, will involve with fixtures \$6,000. One competitor. Reason of selling out ill health. Address, if you mean business, D. L., care Jewelers' Circular.

FOR SALE—A new Kesselmiller's lathe, never been used, with all the attachments, back center, slide rest, jewelry attachment, and full set of chucks, purchased only November 20th, 1882, of Mr. Kesselmiller himself. Will sell complete for \$100. Address Milton Kohler, Hagerstown, Maryland.

GEORGE E. WILKINS, manufacturer and importer of cutters for watchmakers' use, stem-winding cutters of all the different forms, rounding up cutters of the finest quality, also ratchet cutters. A large stock of second hand and new marine chronometers. No. 21 South Salina street, Syracuse, N. Y.

FOR SALE—An old established jewelry store within 30 miles of New York. Stock and fixtures about \$15,000. Over \$20,000 business a year for past two years. Advertiser owns the premises and would give advantageous lease. Terms easy to responsible party. Address Fellows & Co., 17 Maiden Lane, N. Y.

WANTED—By a young man who has learned the watchmaker's trade, is a thorough jeweler and a first-class salesman, a situation with a practical and scientific workman, where the benefit derived will remunerate him for loss of time. References given and required. Address J., care Jewelers' Circular.

WANTED—Every Jeweler to know that the Pikes Peak Mineral Clock is composed of from fifty to one hundred choice specimens of Gold and Silver Ores, Petrified Woods, Topazes, Agates, etc. Delivered to any express office in the U. S. for \$7.25 each, cash. Send all orders to C. W. Little, wholesale manufacturing and importing jeweler, 324 & 326 15th street, Denver, Col.

FOR SALE—An established jewelry store in a southern city of 8,000 inhabitants, with large manufacturing interests. Stock of goods new and well bought for cash, together with safe, show cases, counter, regulator, etc., will invoice about \$6,000. Arrangements can be made to buy fixtures and part of stock for \$2,000, owner being engaged in the wholesale business in Nashville, Tenn. Address M. T. Graham, Nashville, Tenn.

FOR SALE—A jewelry store in one of the best towns in Colorado. Stock A1, invoice about \$8,000. Will sell tools and material or without, will rent the store, plate glass front, good location. We do not want to sell on account of either poor health or poor business, but simply because we have all the money we want, and have made it all right here in less than four years. None but cash buyers need apply to E. W. Reed, Fort Collins, Colorado.

FOR SALE—As I shall, in the near future, devote my entire attention to the wholesale business, I offer my present retail business for sale, located in a thriving western city of 35,000 population, numerous manufacturers, schools, colleges, railroads, steamboats, etc. Fine corner store, plate glass and iron front, cheap rent, fine show cases and fixtures, large safe, etc. All new less than a year ago, everything first-class and business well established. Sales have run over \$5,000 in a single month. Will sell fixtures, show cases, safe, etc., without stock if preferred, or will reduce stock down to \$5,000, including everything. Fixtures alone about \$2,000. Correspondence solicited from those meaning business. Address A. L. Hosmer, Opera House Jeweler, Quincy, Ills.

BUYERS' DIRECTORY.

NEW YORK.

Assayers and Sweep Smelters.

Wundoehl, H.—Gold and Silver Refiner, Assayer and Sweep Smelter. 21 John Street, N. Y.

Badges and Medals.

Stockwell & Newman—19 John Street. Manufacturers of Badges, Medals and Presentation Pieces in Gold and Silver. Also Jewelry and Mounters of Diamonds. Designs supplied.

Wilkinson, C. B.—Manufacturing Jeweler, 8 John Street, N. Y. Medals, Badges and Masonic Jewelry a Specialty. Designs furnished free upon application.

Band Rings.

Knapp, Charles, 41 Maiden Lane, N. Y. Specialty: Superior Band Rings, also Ring Shanks & Heads for Seal and Diamond Rings.

Bangles and Bangle Rings.

Harrison, Henry—Manufacturer of Gold Bangles and Bangle Rings. Also dealer in Watches and Jewelry. 66 Nassau Street, N. Y.

Black Onyx Jewelry.

Cox & Sedgwick—Manufacturers of Black Onyx Jewelry, No. 26 John St. New York.

Woglom & Miller—Manufacturers of (exclusively) Black Onyx Jewelry, 32 & 34 John St., N. Y.

Blue Enameled Locketts.

Bissinger, Philip & Co.—Importers of Diamonds, Pearls and Precious Stones. Agent for the Bohemian Garnet Goods. Blue Enameled Locketts, 22 John St., N. Y.

Hess & Schliesser—Importers of Diamonds, Fine Jewelry and Novelties in French Goods. Specialties: Gold and Blue Enameled Locketts, Charms and Crosses. 25 Maiden Lane.

Bohemian Garnet Jewelry.

Bissinger, Philip & Co.—Importers of Diamonds, Pearls and Precious Stones. Sole Agent for the Bohemian Garnet Jewelry. Blue Enameled Locketts. 22 John St.

Boxes, Wood Mailing and Nested.

Maine Manufacturing Co.—Successor to Swift Manufacturing Co., Makers of Wood Mailing and Nested Boxes for mailing and express purposes. No. 12 Courtland street, N. Y.

Castings.

C. H. Leonhardt—Manufacturer of Fine Jewelry and Charms. All kinds of Moulding and Casting in Gold and Silver done for the Trade; largest assortment of Models. 65 and 67 Nassau Street.

Clock Companies.

Ansonia Clock Co.—Manufacturers of every description of Clocks. 11 to 21 Cliff street, New York.

Kroeber, F.—Manufacturer and Dealer in American and French Clocks, No. 8 Cortlandt Street.

New Haven Clock Co.—62 Reade Street, N. Y.

Seth Thomas Clock Co.—20 Murray Street, N. Y.

Waterbury Clock Co.—M. Bailey, Treasurer, Manufs and Jobbers, No. 4 Cortland St., N. Y., and No. 197 State Street, Chicago.

Welch, E. N. Mfg Co.—6 Warren Street, New York. E. C. Hine, Treasurer and General Manager. 170 State Street, Chicago, F. E. Morse, Agent.

Wm. L. Gilbert Clock Co.—No. 6 Murray Street, Manufacturers of Clocks. Factories, Winsted, Conn.

Corals and Coral Jewelry.

Cuppia, L. A.—Importer of Coral and Silver Filigree Jewelry, 19 Union Square, N. Y.

Errico Bros.—Importers of Coral, Conch Shell and Silver Filigree Jewelry. Loose goods a specialty. 31 John Street, New York.

Cameo Cutters, Etc.

Peiter, Theodore—Cameo and Intaglio Engraver. Patentee of the Cameo-Intaglio. No. 2 Bond Street, near Broadway, Room 4 New York.

Charms & Gold Watch Keys.

Rupp & Held—Manufacturing Jewelers, Charms and Gold Watch Keys, with French and English Rachets, a specialty. 15 John St., N. Y.

Crucibles.

Berge, J. & H.—Established 1850, Manufacturers and Importers of Sand Crucibles, Covers, Chemical Porcelain, Glassware, and Jewelers' and Assayers' Supplies, 95 John Street, N. Y.

Berge, J. & Son—Importers of Sand Crucibles and Covers, Jewelers' Tools and Materials. Manufacturers of Berge's Improved Assay and Enamel Furnace, Assay and Enamel Muffles, &c. 112 William St., N. Y.

Cutlery.

Harrison Bros. & Howson—Manufacturers of Fine Ivory and Pearl Table and Pocket Cutlery, Carvers in Cases; Nutpicks, Nutteracks and goods suitable for the jewelry trade. 126 Chambers Street. W. C. Burkinshaw, Sole Agent.

Diamonds and Diamond Jewelry.

- Anderson, Otis**—Diamond Merchant and Broker, always ready to pay cash for bargains in Diamonds and Precious Stones, 4 & 6 John Street, N. Y.
- Bernhard, A. & Co.**—Importers of Diamonds and Manufacturers of First-Class Diamond Jewelry. Diamond Settings for Manufacturing Jewelers. Design Sheets for the Trade free of charge. 2 Maiden Lane, New York.
- Bernhardt, Richard**—Diamond Broker and Importer, 65 Nassau Street (Room 6), N. Y. Paris, 20, rue des Petites-Écuries.
- Bissinger, Philip & Co.**—Importers of Diamonds, Pearls and Precious Stones. Agent for the Bohemian Garnet Goods. Blue Enamelled Lockets. No. 22 John St., N. Y.
- Bornemann, Louis.**—Importer of Diamonds and Manufacturer of Rich Diamond Jewelry, 19 John Street, New York.
- Bruhl, D. & M.**—Established 1848. Importers of Diamonds and Precious Stones. 14 Maiden Lane, New York. Branch office, Paris. Also 111 Broad Street, Providence, R. I.
- Brunswick, S. & Co.**—Importers of Diamonds. 17 Maiden Lane, New York. Paris, Rue Lafayette. Amsterdam, Damstraat.
- Chalumeau, D.**—Diamond Jeweler and Manufacturer of Mountings. Novelties and Artistic Jewelry. No. 3 Maiden Lane, New York.
- Engelmann, M. & Co.**—Importers of Diamonds, Pearls and Precious Stones. Specialties in Fine Colored Stones. 192 Broadway and 1 and 3 John Street, N. Y. Paris, 1 Boulevard St. Denis.
- Faulkenau, Oppenheimer & Co.**—Manufacturers. Diamonds and Diamond Jewelry. 40 Maiden Lane, N. Y.
- Fera, Henry**—Importer of Diamonds, and Manufacturer of Fine Diamond Jewelry. 4 & 6 John Street, New York. Amsterdam, Holland, 23 Loojersgracht.
- Fox, M. & Co.**—Importers of Diamonds, Rubies, Sapphires and Fancy Gems. No. 1 Maiden Lane, New York.
- Friend S. & Son**—Brokers and dealers in Diamonds 33 John Street, cor. Nassau St. New York.
- Hedges, Wm. S. & Co.**—Importers of Diamonds, No. 170 Broadway, corner Maiden Lane.
- Heller & Bardel.**—Manufacturers of Diamond and Pearl Jewelry, and Dealers in Diamonds, Pearls, &c. 13 John Street.
- Herbert, R. J.**—Diamond Broker and Dealer, 26 Maiden Lane.
- Hirschberg, Sig.**—Manufacturer of Fine Diamond Mountings. No. 76 Nassau Street, New York.
- Kuhn, Doerflinger, & Co.**—Manufacturing Jewelers and Importers of Diamonds, 18 John Street, New York.
- Lacroix & Verpillier.**—Manufacturers of Fine Gold Jewelry, Diamonds a specialty. 19 East Fifteenth St., near Union Square, N. Y.
- Leberthon, L. M.**—Importer of diamonds and watches. Manufacturer of jewelry. 14 John St. Fine stones a specialty.
- Lowenstein, M. A.**—Importer of Diamonds, Pearls, Precious Stones and Jewelry. 182 Broadway, N. Y.
- Neresheimer, E. Aug. & Co.**—Importer of Diamonds. No. 21 Maiden Lane, New York.
- Mulford & Bonnet**—Jewelers and dealers in Diamonds. 21 Maiden Lane, New York.
- Randel, Baremore & Billings**—Importers of Diamonds, corner Maiden Lane and Nassau St.
- Schilling & Nissen**—Dealers in Diamonds and Diamond Jewelry. No. 51 Nassau Street, New York, near Maiden Lane.
- Smith, Alfred H. & Co.**—Importers of Diamonds, No. 182 Broadway.
- Stern & Stern**—Importers of Diamonds and Manufacturer of Diamond and other Jewelry. No. 6 Maiden Lane, N. Y.
- Taylor & Brother.**—Importers of Diamonds and Diamond Jewelry. 676 Broadway.
- Voelker, C. T.**—Manufacturer of 18-k. Diamond Mountings, Diamond Jewelry and Roller Chain Bracelets. 189 Broadway, New York.
- Wickham, D. H. & Co.**—Importer of Diamonds. No. 31 Holborn Viaduct, London, 24 Maiden Lane, New York.

Wolff, G. A.—Importer of Diamonds, Rubies, Sapphires, Pearls, and other Precious Stones, 35 Maiden Lane, New York. 12 Rue de Chateaudun, Paris.

Diamond and Pearl Setter, &c.

Archibald, Wm.—Diamond Setter for the Trade. Cameos, Pearls, Turquoises, Garnets, Amethysts, Doublets, Foil Backs, white and colored. Imitation Stones. 73 Nassau Street, N. Y., room 7.

Diamond Cutters.

Hermann, I.—Importer of Diamonds and Precious Stones. Diamond Cutter and Polisher. Manufacturer of Diamond Jewelry. 19 East 15th Street, New York.

Levy, Herman.—Importer, Cutter and Polisher of Diamonds. 105 Fulton Street, New York.

Dials, &c.

Farnsworth, C. E. & Co.—Successors to J. T. Gold, Enamel Watch Dial Makers. 81 Nassau Street, N. Y.

New York Dial Co.—Manufacturers of Fine Watch Dials. Henry Abbott, Agent, No. 7 Maiden Lane, N. Y.

Enamelled Clock Dials and Figures.

Caeser Bros.—Manufacturers of Enamelled Clock Dials, also letters and numbers for signs. 230 and 232 East 25th Street, New York.

Enamelers, Etc.

Nutt, J. D.—Enameler on Gold, Silver, and Copper. Linen finished Buttons and Studs. Enameling in colors. 32 and 34 John Street, New York.

Orr, J. C.—Enameler on Fine Jewelry. Enamelled in Colors. Linen Finished Buttons and Studs. Band Bracelets. No. 75 Nassau Street, N. Y.

Electroplaters, &c.

Jeandheur, F. & Son,—Gold and Silver Electro Platers & Fire Gilders, coloring Etruscan and Gold Jewelry a specialty. 125 Fulton St.

Engravers—Stone Seal, Etc.

Fackner, Edward—Carver, Engraver and Chaser on Jewelry and Pencil Cases, lettering, &c., 19 John Street.

Holland & Gosling—Stone Seal Engravers. Precious Stones inlaid and enerusted with Diamonds. No. 176 Broadway, New York, (fifth floor per elevator). Cameos cut and repaired.

Knapp, Chas. Engraver, Die Sinker & Stamper for Jewelry purposes. Ring Shanks & superior Band rings, 41 Maiden Lane, N. Y.

Meister, H.—Engraver and Chaser on Fine Jewelry, Badges, Monograms, Coats of Arms, etc.; also Enameling, Coloring and Polishing. No. 59 Nassau Street, New York.

Park, Wm.—The Stone Seal Engraver, Arms, Crests, Monograms, etc., engraved on precious stones, 26 John Street, New York.

Weston, James F.—Stone Seal Engraver and inluster of Precious Stones. Coats of Arms, Masonic, Odd Fellows, and other devices engraved. 32 John Street.

Fancy Goods, Clocks, Bronzes, Etc.

Le Boutillier & Co.—Importers of Fancy Goods, Clocks, Bronzes, &c., 3 Union Square.

Taylor & Bro.—Importers of French Clocks, Bronzes, etc. 676 Broadway, N. Y.

Gold and Silver Cane Heads.

Simons Bro. & Co.—Manufacturers of Gold Headed Canes. 611 and 613 Sansom street, Philadelphia.

Gold and Silver Plating, Etc.

Battle, A.—Gold and Silver Plating and Fire Gilding. 79 Nassau Street, Room 17, N. Y. Watches and Jewelry a Specialty.

Gold Band Bracelets.

Harrison, Henry.—Manufacturer of Gold Band and Buckle Bracelets. 66 Nassau Street, N. Y.

Gold Chains, Etc.

Beck, J. & Son, Manufacturers of Fine Gold Chains and Chain Bracelets, 10 Liberty Place, near Maiden Lane, N. Y.

Carter, Sloan & Co.—Manufacturers of Fine Gold Chain, Whiting Building, 4th St. and Broadway.

Dorrance, Edge & Co.—Manufacturers of the Celebrated Woven Fabric Gold Chain, No. 15 John Street.

Kaufmann Bros.—Manufacturers of Gold Chains, and Chain Bracelets, 26 John Street; Factory, 331 and 333 Bowery, N. Y.

Kohn, Alois & Co.—Manufacturers of Gold Chains. 9 Maiden Lane, N. Y.

Saxton, Smith & Co.—Manufacturers of Fine Gold Chain, No. 14 John Street, N. Y.

Smith, W. & Co.—Manufacturers of Gold and Silver Chains, Jewelry, etc. No. 25 Maiden Lane, N. Y.

Cold Goods.

Hale, S. W. & Co.—Manufacturers of Jewelry of Artistic Design. No. 694 Broadway, N. Y.

Gold Pens, Etc.

Aikin, Lambert & Co.—Manufacturers of Choice Gold Pens, Cases, Holders, Toothpicks, etc., 23 Maiden Lane, N. Y.

Faber, Eberhard,—Manufacturer of 16-karat Gold Pens and Pencil Cases, Nos. 718 and 720 Broadway, N. Y.

Johnson, E. S. & Co.—Manufacturers of Gold Pens, Pen Holders and Pencils. Cor. Maiden Lane and Nassau Street, New York.

Smith, H. M. & Co.—Manufacturers of Gold Pens and Holders, Tooth Picks, Pencils, etc. Sole Manufacturers of Sprague's Patent Gold Fountain Pen. Importers of Nickel and Silver Watches. 173 Broadway, New York.

Gold Rings.

Barnet Bros. & Powell—Manufacturers of Solid Gold Rings, 15 John Street, New York. Factory, Newark, N. J.

Bowden, J. B. & Co.—Manufacturing Jeweler.—Solid Gold Rings a specialty, 1 Maiden Lane.

Ely, W. H.—Manufacturer of Solid Gold Rings of every description. No. 58 Nassau Street.

Kroll, H.—Manufacturing Jeweler. 78 Nassau Street, New York. Specialty: Solid Gold Stone Rings. All kinds of Fine Jewelry made to order, also Repairing for the Trade.

Durlach, Henry—Manufacturing Jeweler. No. 75 & 77 Nassau St. Seal, Cameo, Amethyst and Garnet Rings a specialty.

Peckham, Wm. H.—Manufacturers of Solid Gold Seamless Rings, and Fancy Embossed Rings, Patent Spectacles, Jewelry, etc. No. 4 Liberty Place N. Y.

Radler, K.—Manufacturing Jeweler. Gold Rings and Lockets a specialty. No. 39 Maiden Lane, New York.

Sauter, L.—No. 1 Maiden Lane, New York, Manufacturer of Stone Rings of every description, as Diamond, Cameo, Onyx Turquoise, etc., Scarf Pins, Scarf Rings, Studs and Buttons.

Schnurbusch, H.—Manufacturer of Solid Gold Rings. Specialty: Seal, Cameo, Pearl, Turquoise, Amethyst, Onyx and Garnet Rings. No. 3 Maiden Lane, N. Y.

Shafer & Douglass.—Manufacturers of all kinds of Seal, Stone, Turquoise, and fancy rings. No. 7 Maiden Lane, N. Y.

Sinnock & Sherrill.—Manufacturers of Stone Rings. No. 3 Maiden Lane, N. Y.

Hair Jewelry.

Bernhard, A. & Co.—Manufacturers of Fine Hair Jewelry. Pattern Book of 2,700 designs free of charge to the First-class Trade. 2 Maiden Lane, New York.

Moutoux, Wm. E. & Co.—Manufacturers of Fine Hair Mountings in Gold. Grand catalogues for the trade. 81 Nassau St., Rooms 1 and 2. Finest work and lowest prices.

Sauter, L.—Manufacturer of Fine Gold and Hair Jewelry and Device Work. Pattern Book sent on application. No. 1 Maiden Lane, N. Y.

Schwencke O.—Manufacturer of Fine Hair Jewelry Orders from the country promptly attended to. No. 43 Maiden Lane.

Jewelry Cases, Fancy Boxes, Etc.

American Morocco Case Co.—7 and 9 Bond St., N. Y., make a specialty of Rich Jewelry and Silverware Cases for the fine Retail Trade. Also Improved Trays for Watches, Rings, etc.

Braun, Chr. E.—Manufacturer of Fine Jewelry Boxes and Trays for Show Cases and Trunks. No. 62 Chatham Street, New York. Trays for Show Cases and Trunks a Specialty.

Bricka & Keller—Manufacturers of Morocco Cases for Cutlery, Silverware, Jewelry, etc. Sample Cards and Rolls. Cases in Rosewood, Black Walnut, etc. 52 Nassau Street, New York.

Dennison Mfg Co.—Manufacturers of Morocco, Plush and Velvet Jewelry and Silverware cases. New York, Boston, Philadelphia, Chicago, Cincinnati and St. Louis.

Ettlinger, L. & Sons.—Manufacturers of Fine Cases for Jewelry, Watches and Silverware. Trays for Travelers and Show Cases. Cases to Order a Specialty. No. 80 Nassau St., N. Y.

Haensler, Chas. C.—Manufacturer of Fine Morocco Cases for Jewelry and Silverware. Toilet Boxes, etc. Trays for Show Cases and Windows. 14 John Street, New York.

Jackson, S. C., 180 Broadway, N. Y., Manufacturer of Fine Cases for Jewelry, Silverware, &c.

Kohn, Solomon & Co.—Manufacturers of Fine Morocco Cases for Jewelry, Watches, etc. 15 John Street, New York.

Kron & Krumpel—Manufacturers of Fine Morocco and Plush Cases for Watches, Jewelry, Silverware, etc. 169 William Street, Room 11, New York. Trays for Jewelers and Sample Trays for Travelers a specialty.

Lauten, Edw. A. & Co.—No. 4 Great Jones St., Manufacturers of fine Velvet, Brocade, Plush and Morocco Boxes, for Jewelry, Watches and Silverware, Patent Ring, Ear Ring and Gents' Scarf Pin Trays.

Loehr & Koerner—Manufacturers of Morocco, Velvet, Satin, Jewelry, Watches and Silverware Cases, Jewel, Work Boxes, etc., Fancy Trays and Store Fittings to order. 96 Liberty St.

New York Morocco Case Co.—Cases for Jewelry, Watches, Silverware. Boxes and Trays for Jewelers' Travelers. Show Cases and Window Fittings. No. 69 Nassau Street, New York.

Schien, Charles E.—Manufacturer of Cases for Jewelry and Silverware, No. 85 Nassau St., N. Y. Show Case Trays, etc., at short notice.

Schwarz, N.—Manufacturer of fine Cases for Jewelry and Silverware, 866 Broadway, near 17th street, N. Y.

Steinle, E.—Manufacturer of Cases for Jewelry of all kinds. Also Cases for Mathematical and Surgical Instruments and for Trays for Travelers' Trunks, etc. 66 Nassau Street, N. Y.

The Novelty Case Co.—Manufacturers of Jewelry and Silverware Cases of all description. Fancy boxes and specialties in great variety. No. 114 East 14th Street.

Welch & Miller—Manufacturers of Morocco, Velvet, and Satin Jewelry Cases, Trays, &c., Telescope Sample Cases with flexible Trays. Complete stock on hand. 169 Broadway

Wiggers & Froelick—No. 60 Nassau street—Manufacturers of Cases for Jewelry, &c., of every description. Trays for Show-cases, Stands for Show-windows, etc.

Jewelers' Findings.

Dennison Mfg Co.—Paper Jewelry Boxes, cards, tags, pink and white cotton, etc. New York, Boston, Chicago, Cincinnati, Philadelphia, St. Louis.

Ettlinger, L. & Sons.—Manufacturers of Jewelers' Paper Boxes and Findings. Morocco Paper, Satin or Plush Lined Wooden Corner Stops Jewelry and Silverware Boxes. 80 Nassau Street, New York.

Lehmann, Ludwig.—Manufacturer of Jewelers' Findings. Tags, Pink and White Cotton, and Tissue Paper. Specialty, Fine Paper Boxes for Jewelers and Silversmiths. 122 Fulton Street.

Valfer, S. & Co.—Manufacturers and Dealers in Jewelers' Boxes, Tags, Cards, Paper and Findings. Office and Salesroom, 66 Nassau street, New York.

Jewelry—Fine.

Aikin, Lambert & Co.—Manufacturers General stock of Reliable Jewelry, 23 Maiden Lane.

Alling & Co.—Manufacturing Jewelers, 170 Broadway.

Alford, C. G. & Co.—Manufacturers. General line fine and Reliable Goods. Specialties in Onyx Goods and Chain, 200 Broadway, New York.

Baldwin, Sexton & Peterson—Makers of Fine Jewelry and Importers of Diamonds, etc., corner Broadway and Fourth Street.

Ball, W. H.—Manufacturer of Gold Jewelry. Bracelets and Bangles of all kinds a specialty. 9 John Street, N. Y.

Barthman, Straat & Co.—Manufacturers of Fine Jewelry. Roman Goods, Rings, Diamonds. No. 43 Maiden Lane.

Bernhard, A. & Co.—Manufacturers of General Fine Work. Specialties: Diamond Jewelry, Diamond Settings, Hair Jewelry, Fancy Rings, Rose Diamond Monogram and Onyx Work. 2 Maiden Lane, New York.

Bissinger, Philip & Co.—Importers of Diamonds, Pearls and Precious Stones. Sole Agent for the Bohemian Garnet Jewelry, Blue Enameled Lockets. 22 John St., N. Y.

Brown, Thos. G. & Sons—Manfrs of Rich Jewelry Necklaces, Locketts, Bracelets, Sleeve Buttons, etc., 5 Bond Street, N. Y.

Bryant & Bentley—Manufacturing Jewelers. Kings a specialty. 12 Maiden Lane

Carter, Sloan & Co.—Manufacturing Jewelers Whiting Building, 4th St. and Broadway.

Champerois & Co.—No. 5 Maiden Lane, manufacturers of Engraved and Enameled Gold goods, in Sets, Ear Knobs, Bracelets, Studs, Lace and Shawl Pins, Jet cluster and Onyx goods, also "Best Lever" Sleeve Buttons.

Chatellier, Joseph F.—Manufacturing Jeweler, No. 604 Broadway, N. Y.

Churchill, Lewis & Co.—Manufacturers of Fine Jewelry. 692 Broadway, cor. Fourth St., N. Y.

Cohn, J. J.—Importer and Manufacturer of Whitby Jet, Rubber and Pearl goods. Gold and Rolled-plate Jewelry, etc. 12 Maiden Lane, New York.

Cook, Groeschel & Co.—Manufacturers of Fine Jewelry and Locketts, 191 Broadway (over Mercantile Bank,) N. Y.

Cottle S. Co.—Manufacturers of Fine Jewelry. Waltham Building, 5 Bond Street, N. Y.

Cox & Sedgwick—Manufacturers of fine Onyx and Colored Jewelry. 26 John St., New York

Day & Clark—Manufacturers of Fine Jewelry, Lace Pins, Ear Rings, Studs, Locketts, &c., 192 Broadway, cor. John St., New York.

Ephraim, L.—Wholesale Dealer in Fine Gold and Plated Jewelry. Also a Full Line of Materials, Tools and Optical Goods. Established 1870. No. 8 John Street, N. Y., P. O. Box 2258.

Geoffroy, Arthur R. & Co.—Manufacturing Jewelers. Novelties in Diamond Goods. No. 23 Maiden Lane, N. Y.

Goddard, John M.—Manufacturing Jeweler,—Seal Rings and Fine Locketts a specialty, No. 3 Maiden Lane, N. Y.

Goldsmith & Cohen—Manufacturing Jewelers, 3 Maiden Lane, New York.

Greason J. R. & Co.—Successors to Arthur, Rumrill & Co., 182 Broadway. Manufacturers of Fine Jewelry and Gold Chains, also Diamond Mountings.

Greene Wm. C. & Co.—Goldsmiths; Manufacturers of Rich Sets in Taper Wire Coral. Office, 192 Broadway.

Hale, S. W. & Co.—Manufacturers Rich Jewelry, Whiting Building, Broadway and 4th Street.

Hartje, G. & F.—Manufacturers of Diamond and Fine Jewelry, 860 Broadway, cor. 17th street, N. Y.

Hartmann, P.—Manufacturer & Importer of Fine Gold, Diamond, and Filigree Silver Jewelry, No. 36 Maiden Lane. P. O. Box 2,454.

Haskell, H. C.—Manufacturing Jeweler. Seal Rings a specialty. Special attention to Jobbing of every description. 12 John street.

Hedges, A. J. & Co.—Manufacturing Jewelers, 6 Maiden Lane.

Henderson & Winter—Jewelers, No. 15 Maiden Lane, New York. Specialties—Stone, Camco, Onyx, Amethyst, Topaz, Pearl and Turquoise Rings.

Hunt & Owen.—Manufacturing Jewelers. Office 3 Maiden Lane.

Jeanne Brothers.—Manufacturers of Diamond Mountings & Rich Jewelry. 1 Maiden Lane.

Kennedy, Frank S.—Manufacturer and Wholesale Dealer in Jewelry and Gold and Silver Thimbles. No. 13 Maiden Lane, New York.

Kremetz & Co.—Manufacturing Jewelers, No. 192 Broadway, N. Y.

Kuhn, Doerflinger & Co.—Manufacturers of Enameled and Roman Band Bracelets, also Fine Locketts Pendants and Lace Pins. 18 John street.

Lennon, John D.—Manufacturing Jeweler, 142 Fulton Street. Stone Locketts and Rings; also Badges and Emblems of all kinds.

Malliet, C. G. No. 9 John St., Jewelry to order and repairing of all kinds.

Marx Kossuth & Co.—Manufacturing Jewelers. 39 Maiden Lane.

Mayer, B.—Manufacturer of Fine Jewelry, and Dealer in Watches, 71 Nassau street, cor. John street, New York.

Mayer, Max.—Dealer in Gold and Fine Rolled Plate Jewelry of every description. 71 Nassau St., N. Y.

Milfer Bros.—Manufacturers of Fine Jewelry, Locketts, Sleeve Buttons, Studs, &c., 7 Maiden Lane, N. Y.

Moore & Horton.—11 Maiden Lane, Manufacturing Jewelers, Rings, Studs, Collars and Sleeve Buttons, Pins, Ear-rings, &c.

Muhr's, H., Sons.—Manufacturing Jewelers. Solid Gold and Filled Rings a specialty. Also Manufacturers of the celebrated Crown Filled Watch Case. 1½ Maiden Lane, N. Y.

Mulford & Bonnet—Jewelers and dealers in Diamonds. 21 Maiden Lane, New York.

Myers, S. F. & Co.—Manufacturing and Wholesale Jewelers—all grades—Illustrated Catalogues sent to the trade. 179 Broadway, N. Y.

Owen, G. & S. & Co.—Manufacturing Jewelers. Office, No. 3 Maiden Lane.

Richardson, Enos & Co.—Manufacturers of Fine Gold Jewelry, Gold Chains, Locketts, Crosses and Necklaces. Colored and Etruscan Work. No. 23 Maiden Lane, New York.

Richardson, J. W. & Co.—Manufacturers of Jewelry. Masonic and other Emblems. 196 Broadway, N. Y. Manufactory, Providence, R. I.

Riley, J. A. & Co.—Manufacturing Jewelers. Etruscan Gold and Roman Bracelets, Lace Pins, Ear Rings, Scarf Pins, Brooch Pins, etc. Nos. 7 and 9 Bond Street, N. Y.

Ripley, Howland & Co.—Manufacturers of Fine Jewelry and Platinum Tipped Diamond Settings. No. 17 Maiden Lane, N. Y.

Sauter, L.—Manufacturer of Fine Jewelry, Solid Stone Rings and Studs a specialty. Jobbing for the trade. 1 Maiden Lane, New York.

Sexton & Cole—Manufacturing Jewelers, Colored Gold and Onyx Goods a specialty. No. 30 Maiden Lane.

Shafer & Douglas, Manufacturing Jewelers—Roman Goods, Lace Pins, Cameo Sets, etc., Stone Rings, etc. No. 7 Maiden Lane, N. Y.

Sheafer, W. H. & Co.—Manufacturing Jewelers, Specialty Bangles and Bracelets, 15 John St., N. Y.

Steele, J. W.—Successor to Brainerd, Steele & Co., Manufacturer of Fine Jewelry and Brainerd's Patent Locketts. No. 9 Maiden Lane, N. Y.

Stites, D. H. & Son—Manufacturers of Fine Jewelry, Rolled Plated Goods and Chains, Parisian Diamond Rings, Studs and Earrings a specialty. 41 Maiden Lane, N. Y.

Stites' Sons, E.—Manufacturers of Fine Jewelry. No. 14 John Street, N. Y.

Strauss, Jacob.—Full Line of Gold and Plated Jewelry, and Importer of Watches. 18 John Street, New York.

Street, Geo. O. & Sons.—Established 1837. Makers of Fine Jewelry, strictly first-class goods of our own make. No. 15 John Street, New York.

Terhune, Charles F.—Manufacturing Jeweler, 194 Broadway, N. Y.

Thoma, Ernest—Manufacturer of Fine Jewelry, Sleeve Buttons, Rings, Ear-rings, &c. No. 173 Broadway, N. Y. Factory, Hackensack, N. I.

Trier Bros.—Importers of Garnet, Whitby Jet and Amber Jewelry, Silk Guards, Opera, Field and Marine Glasses, Pearl Card Cases. Also a full line of Gold and Plated Jewelry. 15 Maiden Lane, N. Y.

Unger Bros.—Makers of Fine Gold Jewelry, consisting of Lace Pins, Earrings, Collar Buttons, Band Rings White Enameled Studs, etc. Also Patent Onyx Brocelets, 9 Maiden Lane, N. Y.

Wheeler, Parsons & Hays.—Manufacturers of Fine Jewelry, Watch Cases, Gold Chains, &c. and Dealer in American and Swiss Watches, No. 2 Maiden Lane, N. Y.

Wienhold, Joseph.—Manufacturer of Fine Jewelry and Diamond Setter. 24 John St.

Ward, Thos. M.—Manufacturer of Fine Jewelry, Diamond Mountings a specialty. No. 25 John Street, N. Y.

Woglom & Miller.—Manufacturers of Black Onyx Goods exclusively. 32 & 34 John Street, N. Y.

Jewelry—Rolled Plate.

Frick, John & Co.—Fine Rolled Plate Jewelry of all kinds. Repairing of every description. 21 and 23 Maiden Lane, N. Y.

Mauran, J. T.—Manufacturer of Fine Rolled Plate Jewelry, No. 15 Maiden Lane, N. Y.

Richards, E. Ira & Co.—Manufacturers of Fine Rolled Plate Jewelry, No. 200 Broadway, N. Y.

Weil, Leopold & Co.—Manufacturers of Rolled Plate Jewelry of every description, 16 Maiden Lane, N. Y.

Jewelers' Tools, etc.

Fisher, James J.—Dealer in Watchmakers' and Jewelers' Materials, Files, Tools, Silk Guards, Spectacles, etc., 697 Broadway, N. Y.

Frasse & Co.—Importers of Stubb' French, Swiss, German and Sheffield Tools, Files and Steel Wire for Watchmakers, Jewelers, etc., 62 Chatham street, N. Y.

Friedenthal, A. & Co.—Importers and jobbers of Watchmakers' and Jewelers' Tools, Materials, etc. 43 Maiden Lane, N. Y.

Friedlander, R. & L.—264 Bowery—Importers of Watchmakers' tools and materials.

Kurtz, F. P.—Manufacturer of Jewelers Machinery, Tools, Rolling Mills, Presses, Polishing Lathes, &c. 97 Cliff St., N. Y.

Levy, Dreyfus & Co.—Importers and Jobbers of Watchmakers' and Jewelers' tools and materials of every description. 11 Maiden Lane, N. Y.

Reichhelm & Koester.—Importers of Jewelers' Tools, Files, etc. Manufacturers of Brushes and Buffing wheels; also Patent Gas Furnaces for Melting, Plating, Enamelling, Annealing, etc. 80 Nassau St., N. Y.

Lapidaries.

Fox, M. & Co.—Practical Lapidaries, No. 1 Maiden Lane, New York.

Graham & Co.—Practical Lapidaries, Cutters and Polishers of all kinds of Precious Stones. Miners' Relics Cut, Polished and Mounted. Miniature, Locket and Clock Glasses. 80 Nassau St., N. Y.

Kordmann & Michel.—Lapidaries. Dealers in Precious Stones. Cutting and Polishing Rubies, Sapphires and other Gems a specialty. Drilling done promptly. 59 Nassau St., N. Y.

Manufacturing Jewelers.

Waterman & Lehmann.—Manufacturing Jewelers and Dealers in Diamonds. Diamond Work, and Fine fancy Rings a specialty, any piece of single work made to order. 37 Maiden Lane, N. Y.

Masonic Jewelry.

Lennon, John D.—Manufacturer of Masonic, Odd Fellows, Athletic Clubs and other Jewelry, No. 142 Fulton Street, New York.

Luther, John F.—79 Nassau Street. Manufacturer of Fine Presentation Jewels for all Societies. Knights Templars, Crosses, Badges, &c.

Popper, H.—Manufacturer of Medals and Badges for Military, G. A. R., Shooting, Masonic, Odd Fellows, Knights of Pythias, etc. 91 Essex St., New York.

Wilkinson, C. B.—Manufacturing Jeweler, 8 John St., N. Y. Medals, Badges and Masonic Jewelry, a specialty. Designs furnished free upon application.

Optical Goods.

Friedlander, R. & L.—264 Bowery. Dealers in Optical Goods.

Opticians.

Burbank Man'g Co.—Manufacturers of Spectacles and Eye Glasses of all descriptions, in gold, silver, etc., 14 Maiden Lane, N. Y.

DuBois, Geo. W. & Co.—Importers of Watches and Optical Goods. 36 Maiden Lane, N. Y.

Kahn, Hanover & Co.—Importers of Spectacles, Eye-Glasses and Optical Goods generally, and Scientific Instruments of every description. 32 Maiden Lane, New York.

Laurencott, J. B.—Importer of Watch Glasses, Optical and Fancy Goods, Clocks, Bronzes, etc., 33 Maiden Lane, N. Y.

Levy, Dreyfus & Co.—Importers of Spectacles and Eye Glasses and Optical Instruments of every description, No. 11 Maiden Lane, N. Y.

Lorsch, Albert.—Manufacturer of the Patent Accommodating Spectacles and Eye Glasses in Gold, Silver and Steel, and other Optical Goods, 37 Maiden Lane, N. Y.

Major, W. E.—Importer of Optical and Fancy Goods, Spectacles, Eye-Glasses, Silk Guards, Opera Glasses, Field Glasses, Telescopes, Etc. Also Dealer in Chains and Jewelers' Findings. No. 42 Maiden Lane, New York.

New York Optical Co.—Manufacturers of Spectacles, Eye-Glasses and Cases, No. 43 Maiden Lane, New York. (P. O. Box 2309).

Spencer Optical Manufacturing Co.—Gold, Silver, Steel, Nickel and Plated Spectacles; Gold, Celluloid, Steel, Nickel and Rubber Eye Glass and Opera Glasses. 13 Maiden Lane, N. Y.

Precious Stones, &c.

Becker & Hahn.—Importers of Precious Stones. Cameos, Intaglios, Seals, Black Onyx, etc. 26 John Street, New York.

Bissinger, Philip & Co.—Importer of Diamonds, Pearls and Precious Stones. Agent for the Bohemian Garnet Goods. Blue Enameled Locketts. No. 22 John St., N. Y.

Bishop, Victor & Co.—33 Maiden Lane, Importers of Precious Stones, Cameos, &c. Also Manufacturers of Coral Jewelry.

Breidenbach, R. A.—Importer of Precious and Imitation Stones, Black Onyx, Cameos, Intaglios, Turquoise, Pearls, Bloodstones, Sardonyx, Nicolos, Topaz, etc. 85 Nassau St., New York.

Daue, Wm. & Co.—Importer of Precious and Imitation Stones. No. 202 Broadway New York.

Fox, M. & Co.—Importers of Diamonds and other Precious Stones, No. 1 Maiden Lane, N. Y.

Gruet, Jules.—Importer of Precious and Imitation Stones, Amethysts, Topazes, Cameos, Garnets, doublets, imitation diamonds, pastes, &c., No. 14 John Street.

Guntzburger Bros.—Manufacturers and importers of Precious Stones—Amethysts, Topaz, Cameos, Garnets, Imitation Diamonds, &c. No. 9 Maiden Lane.

Hahn & Co.—Importers of Precious Stones. Cameos, Onyx, Pearls, Intaglios, Amethysts, Garnets, etc. 64 Nassau Street, New York.

Kahn, L. & M.—Importers of precious and imitation stones. 10 Maiden Lane, N. Y.

Tannenbaum, L. & Co.—Manufacturers of Fine Jewelry, and always on hand a specialty of Precious Stones and all kinds for jobbing. 65 Nassau Street, New York.

Silverware.

Gorham Manufacturing Co.—Union Square.

Knowles, J. P. & S. M.—Manufacturers of Sterling Silverware, 20 Maiden Lane, N. Y. Factory, Providence, R. I.

Shiebler, Geo. W.—Manufacturer of Sterling Silverware. No. 8 Liberty Place, near Maiden Lane, N. Y.

Wood & Hughes.—Manufacturers of Fine Silverware. 16 John Street, N. Y.

Whiting Manufacturing Co.—Makers of Sterling Silver Ware. Broadway cor. 4th Street, N. Y.

Silver Filigree Jewelry.

Cuppia, L. A.—Manufacturer of Solid Silver Novelties, and Importer of Silver Filigree, 19 Union Square.

Errico Bros.—Importers of Silver Filigree Jewelry and Italian Works of Art, 31 John Street, N. Y.

Hartmann, P.—Manufacturer of Silver Filigree Jewelry. 36 Maiden Lane, N. Y.

Lauckhardt & Romer.—Manufacturers and Importers of Gold and Silver Filigree Jewelry. 75 and 77 Nassau Street, New York. Repairing and refinishing Filigree Jewelry a specialty.

Silver Plated Ware.

Holmes, Booth & Haydens.—Manufacturers of Silver-Plated Ware. 47 Chambers Street.

Manhattan Silver Plate Co.—Manufacturers of Silver Plated Ware. Showrooms, 23 John St. Factory, 301 to 305 East 22d St., cor. 2d Ave. Address all communications to Factory.

Meriden Britannia Co.—Manufacturers of Silver-Plated Ware. 46 East 14th Street, Union Square.

Meriden Silver Plate Co.—Manufacturers of Fine Silver Plated Ware. No. 30 E. 14th Street, New York.

Middletown Plate Co.—Manufacturers of Superior Electro-Plate. Factories, Middletown, Conn., salesroom, 13 John Street.

Rogers & Bro.—Manufacturers of the finest quality of Electro-Plated Ware. 690 Broadway.

Rogers, Smith & Co.—Manufacturers of Fine Electro Plated Ware. No. 46 E. 14th St., N. Y.

Simpson, Hall, Miller & Co.—Manufacturers of fine Silver-Plated Ware. No. 36 E. 14th Street.

Schade, Henry.—Manufacturer of White Metal and Plated Ware. No. 84 John St., N. Y. Price list and catalogue furnished on application.

Webster, E. G. & Bro.—Manufacturers of Fine Silver-Plated Ware. Office and warerooms, 14 Maiden Lane, N. Y.

Show Cases, Etc.

Hoffman, Geo. A.—Manufacturer of Show Cases. All the latest improved styles on hand and made to order. Celluloid show cases a specialty. Send for catalogue. 148 Chatham Street, New York.

Smith, B. & W. B.—Manufacturers of Patent Improved Dust Proof Show Cases, with Perpendicular Sliding Doors, No. 220 W. 29th St., N. Y.

Spectacle Case Manufacturers.

Bertine, P. D.—Manufacturer of Spectacle Cases, 139 William Street, near Fulton St., New York.

Koenen, A. & Bro.—Manufacturers of Leather Spectacle and Eye-Glass Cases. 81 Nassau St., N. Y.

Stem Winding Attachments.

Abbott, Henry Maker of Stem Winding Attachments, No. 7 Maiden Lane, N. Y.

Thermometers, Etc.

Tagliabue, Giuseppe.—manufacturer of Thermometers, Barometers and Hydrometers. Patentee and sole manufacturer of the U. S. Standard Hydrometer. 302 Pearl Street, near Beekman.

Thimble Manufacturers.

Barker Manufacturing Co.—Manufacturers of Patent Graduated Thimbles, Stiffened Gold, Filled Gold, and Rolled-Plate Gold. 36 Maiden Lane, N. Y. A. Lyons, Agent, Manufactory 19 Snow Street, Providence, R. I.

Burbank Manuf'g Co.—Manufacturers of Gold and Silver Thimbles, 14 Maiden Lane, N. Y.

Ketcham & McDougall.—Improved Gold and Silver Thimbles, Nos. 4 and 6 Liberty Place, near Maiden Lane, N. Y.

Simons Bro. & Co.—Manufacturers of Gold and Silver Thimbles. 611 and 613 Sansom Street, Philadelphia.

Woglom & Miller.—Sole Agents for the "Prime" Thimbles in Gold and Silver, manufactured by Ezra C. Prime. 34 John Street, N. Y.

Watch Companies.

American Watch Co.—Robbins & Appleton, No. 5 Bond Street, N. Y.

The E. Howard Watch and Clock Co.—Cor. Maiden Lane and Nassau Street, N. Y.

Waterbury Watch Co.—Manufacturers of the Waterbury Watch. Factory, Waterbury. Office, 4 Maiden Lane, N. Y.

Watch and Chronometer Jeweler.

Queen, James.—Watch and Chronometer Jeweler and Pallet Maker, 78 Nassau Street, room 8. Pivots inserted in Pinions, Balance, Staffs, etc.

Wennstrom, John.—Watch, Chronometer and Clock Jeweler, Balance and Cap Jewels set and turned down to fit all kinds of American Watches. No. 2 Dutch Street, New York.

Watch Importers, Etc.

Abry, Chas. Leo.—Importer and Manufacturer of Swiss Watches of all grades. 63 Nassau Street.

Aikin, Lambert & Co.—Importers of Watches. Sole Agents for Paul Breton & Chas. Latour, Geneva. A general line of reliable Swiss Watches, Watch Cases, etc. 23 Maiden Lane, N. Y.

Bartens & Rice—20 John Street, Importers of Watches and sole agents in the United States for the celebrated Nicole, Nielsen & Co. Watches.

Cross & Beguelin.—Importers of Watches, Watch Tools and Materials, dealers in American Watches, No. 21 Maiden Lane, N. Y.

Droz, Henry E.—Importer of Watches, and Watch Case Manufacturer. Agent for the "E. Perre-gaux" Watch, and jobber in American Watches. No. 92 Fulton Street, N. Y.

Durfey & Reynolds—Successors to Durfey & Shiebler, Watches, Diamonds, Jewelry. No. 9 John Street, (up-stairs) New York.

Freund Max & Co.—Importers of Watches, Jewelry and Precious Stones, 8 Maiden Lane, N. Y.

Gallet, Julien.—Importer of Watches. No. 1 Maiden Lane.

Ginnel, Henry—Importer of Watches, Tools and Materials, 31 Maiden Lane, N. Y. P.O. Box, 2967

Heinrich, H. H. & Co.—Sole Agents for the Karl Zimmerman Watch, and Importers of Fine Watches and Marine Chronometers. 12 John Street, N. Y.

Herzog, Louis & Co.—Importers of Watches, Dealers in Diamonds and Jewelry, 52 Maiden Lane, N. Y.

Hirsch Bros.—Dealers in Watches and Diamonds and Manufacturers of Jewelry, No. 23 Maiden Lane, N. Y.

Hyde's Sons, John E.—Wholesale Commission Agents, only for Jules Jurgensen, of Copenhagen; Jules Monard, of Geneva; and for other makers of all qualities of Watches, 22 Maiden Lane.

Jandorf, P. & Bro.—Importers of Watches and Jewelry, 196 Broadway.

Keller, L. H. & Co.—Successors to G. A. Huguenin, Importers of Fine Watch and French Clock Materials, No. 64 Nassau Street, N. Y.

Mathey Bros. & Mathez.—Importers of Fine Watches and Sole Agents for the **H. L. Matile's** Watches. No. 16 Maiden Lane.

Oppenheimer Bros. & Veith.—Dealers in Watches and Diamonds, and Manufacturing Jewelers, No. 35 Maiden Lane.

Robert, J. Eugene—No. 30 Maiden Lane, New York. Agent for Louis Audemar's celebrated watches.

Schwob, Adolphe—Manufacturer and Importer of Watches, 11 Maiden Lane, N. Y.

Stern Brothers & Co.—Importers of Swiss Watches and wholesale dealers in American Watches, &c., 39 Maiden Lane.

Scott, J. T. & Co.—Importers of Watches, and Manufacturers of Jewelry, and Jobbers of all Grades of American Watches, 11 Maiden Lane.

Strasburger, Louis & Co.—Importers and Makers of Watches of every description, 15 Maiden Lane.

Watch Cases.

Brown, J. A. & Co.—Manufacturers of the Ladd Patent Stiffened Gold Watch Cases, etc., 11 Maiden Lane, N. Y. Factory, 58 Eddy Street, Providence, R. I.

Dueber Watch Case Mfg Co.—Manufacturers of Gold and Silver Watch Cases. No. 16 Maiden Lane, N. Y. Factory, Newport, Ky.

Fahys, Joseph—Manufacturer of Watch Cases and Dealer in American Movements, 38 Maiden Lane.

Hagstoz & Thorpe.—Manufacturers of Keystone Silver and Boss' Patent Watch Cases. 14 John Street, New York.

Watch and Chronometer Repairers.

Cerf, B.—Practical Watchmaker and Repairer, No. 10 John Street, N. Y. Repairing and adjusting of Fine Watches done for the trade. All kinds of escape and stem-winding wheels cut to order.

Heinrich, H. H. & Co.—Sole Manufacturers of H. H. Heinrich's Patent Auxiliary Balance, and Adjusters and Repairers of Fine Watches and Chronometers. 12 John Street, N. Y.

Lesperance, Theo.—Watchmaker and Wheel Cutter. Also Stoning Nickel Movements. No. 1 Maiden Lane, New York. With Julien Gallet.

Ludeman, W. H.—Chronometer and Watch Maker. Repairing of every description for the trade, 75 and 77 Nassau Street.

Watch Case Repairers.

Feinier, Joseph A.—Watch Case Maker and General Repairer. Specialty in fine Gold and Silver Cases. Jobbing promptly attended to. Nos. 4 and 6 John St., N. Y.

Tarbox, Hiram—Watch Case Repairing, Springing, Polishing and Engine Turning, 79 Nassau Street, also Fourth Ave., bet. 176th and 177th Sts., N. Y.

Watch Glasses, Shades, Etc.

Brown, Edwin H.—No. 85 Nassau Street, Imported and Own Manufacture Watch Glasses, Flat, Flat Concave, Concave, Convex and fine Genevas. Fine fitting solicited.

Watches and Jewelry.

Friedman, Saml.—Wholesale Dealer in Watches and Jewelry, 42 Maiden Lane, N. Y.

Fry & Schieber—Manufacturers of Fine Gold and Plated Jewelry and Importers of Watches, 201 Broadway, N. Y.

Lissauer & Sondheim—Wholesale Jewelers and Jobbers in American Watches, No. 12 Maiden Lane, N. Y.

White, N. H.—Jobber in American Waltham Watches and Chronographs. Waltham make of 14-k. and 18-k. Gold and Sterling Silver Cases. Filled 10-k. and cheap Gold Cases. 11 Maiden Lane, N. Y.

Watch Tools, etc.

Gesswein, F. W.—Manufacturer of Machinery and Tools for Jewelers, Watch, Clock and Watch Case Makers, etc. 39 John Street, N. Y.

Keller, L. H. & Co.—Importers of Watchmakers' and Jewelers' Tools, Materials, etc. 64 Nassau Street, N. Y.

Zimmern, Henry—Importer of Watch Materials, Tools, and Optical Goods, No. 8 Maiden Lane, (first floor.) Sole Agent for A. Hugenin & Gravier. Mainsprings, New York.

PHILADELPHIA

Booz & Co.—Manufacturers of Gold and Silver Watch Cases and Jewelry, 108 South 8th St., Philadelphia.

Bennett, Jacob & Son.—Diamond Setters and Manufacturing Jewelers, 925 Chestnut St.

Bernard & Co.—Manufacturers of fine Roman and Etruscan Jewelry. Designs of every description made to order, 123 & 125 South Eleventh Street, Philadelphia.

Birmingham, Wm. & Co.—Morocco Case Manufacturers. Spectacle and Eye-Glass Cases a specialty, 626 Arch Street, Philadelphia, Pa.

Clark, J. L.—Gold and Silver Refiner and Assayer; Sweep Smelter. Gold and Silver or Platinum bought. 823 Filbert Street, Philadelphia.

Conover David F. & Co.—American Watches, Wholesale Salesroom, Southeast corner 7th and Chestnut Streets, Philadelphia.

Dubosq, J. Carrow—Manufacturer of Fine Jewelry. Particular attention given to repairing Strung Pearl work. 108 South Eighth St., Phila.

Fick, Chas. M.—Stone Seal Engraver. Coats of Arms, Crests, Monograms, Initial Letters and Masonic Emblems, and other devices engraved on all kinds of Precious Stones. Cameos cut and repaired. 618 Chestnut Street.

Goldsmith, M. I.—Importer and jobber of Watch Materials, Tools, etc. 722 Chestnut St., Philadelphia, Pa.

Guilbert, Thos. M. & Co.—Manufacturing Jewelers. Specialty; Flexible Woven Bracelets. 908 Chestnut Street, Philadelphia, Pa.

Hagstoz & Thorpe—Manufacturers of Gold, Silver and Boss' Patent Watch Cases. 19th and Brown Streets. New York office, 14 John St.

Herold, Chas P.—Successor to Hildebrandt, Herold & Co., Manufacturing Jeweler and Diamond Setter. Diamonds. 916 Chestnut Street.

Krieder, Peter L.—Manufacturer of Sterling Silver Ware. 618 Chestnut Street, Philadelphia.

McCarty & Hurlburt—Manufacturers of Gold Spectacles, Silver Thimbles and Plain Rings. Wholesale dealers in American Watches, Jewelry, etc. 131 North Second Street.

Morgan & Headly.—Manufacturing Jewelers, Cameo Sets, Gold Sets, Roman Locketts, Rings, Coral Sets and a general line of rich goods. Corner 10th and Chestnut Streets, Philadelphia.

Morgan, Charles V.—Manufacturer of Morocco and Hardwood Cases. 550 Chestnut Street, Philadelphia. Jewelry and Silverware Cases, Show Case Trays, Mathematical and Surgical Instrument Cases, etc.

Morris, William—Importer of Watch Materials, Tools, Glasses, Spectacles, White Metal and Plated Chains. The attention of the closest buyers is requested. 706 Chestnut St., Philadelphia.

Muhr's, H., Sons.—Manufacturing Jewelers. Solid Gold and Filled Rings a specialty. 633 and 635 Chestnut Street, Philadelphia. 1½ Maiden Lane, New York.

Peters, Reese S.—Manufacturer of Patent Rolled Plate or Filled Watch Cases, Dealer in American Movements, 308 Chestnut Street, Philadelphia.

Robeth, A.—Wholesale Optician, and Dealer in Fine and Plated Jewelry, also Diamonds and Swiss Watches. 825 Market St., Philadelphia.

Rowe, Geo. A.—Stone and Metal Seal Engraver, Die Sinker and Medalist, Intaglio Cutting. Special rates for large quantities to manufacturers. 1002 Walnut Street.

Rosenthal, G. F. C.—Manufacturing Jeweler and Diamond Setter. Engraving and Designing of Monograms a Specialty. No. 917 Sansom Street.

Scherr, L. A. & Co.—Wholesale Dealers in Watches Silver-Plated Ware, Spectacles, Fancy Goods, Watch Materials, etc. 726 Chestnut Street.

Sheafer, W. H. & Co.—Manufacturing Jewelers. Specialty: Band Bracelets. Factory and office—612 and 614 Chestnut street, Philadelphia. Branch office—15 John street, New York.

Simons, Brother & Co.—Manufacturers of Fine Jewelry, Canes, Thimbles, Chains. 611 and 613 Sansom Street.

Vansant, John T. & Co.—611 and 613 Sansom Street, Artisan Hall, Manufacturers and Wholesale Dealers in English Sterling Silverware. Specialties: Tea Sets, Knives, Forks, Spoons, Cups and Napkin Rings.

CHICAGO.

American Watch Company.—of Waltham, Mass. No. 170 State Street, Chicago.

Chicago Watch Case Co.—Manufacturers of Patent Dust Proof Screw Bezel Watch Cases. Cor. Madison Street and Michigan Avenue, Chicago, Ills.

Clapp, Caleb & Co.—Wholesale Jewelers, 63 and 65 Washington Street. Catalogue and price list issued to watchmakers and jewelers.

Cogswell & Wallis, Ag't—Dealers in Clocks, Watches, Jewelry, Silver and Plated Ware, Watch Tools, Materials and Optical Goods, 146 State Street, Chicago.

Dennison Manufacturing Co.—Manufacturers of Jewelers' Paper Boxes, Morocco Cases, Tags, Cards, Pink and White Cotton, Tissue Papers, Sealing Wax, &c., &c., 102 Madison St., Chicago. Boston, New York, St. Louis, and Philadelphia.

Excelsior Sign Co.—Manufacturers of Iron and Wood watch and clock signs. No. 126 Fifth Avenue, Chicago, Ills.

Frese, B.—Watchmaking and Repairing for the Trade promptly attended to. Stem-winding and Escape Wheels cut to order. No. 99 E. Madison Street, Chicago, Ill.

Gilbert, Wm. L., Clock Co.—Manufacturers of Clocks, Regulators, and Time Pieces, and Clock Material of every description, 54 and 56 Madison Street, Chicago.

Giles, Bro. & Co.—Manufacturers and Jobbers in Watches, all classes of Jewelry, Materials, Clocks, Silver Ware, &c. Illustrated catalogues furnished to dealers on application. State and Washington Streets.

Glickauf & Newhouse. 79 and 81 State Street. Importers of Watchmakers and Jewelers Supplies, Optical Goods, Watches, etc.

Hagstoz & Thorpe—Manufacturers of the Keystone Silver Cases and Boss' Patent Filled Cases. H. M. CARLE, Agent, 67 Washington St.

Kearney, Theodore—133 and 135 State Street. Importer and Jobber of Watchmakers' and Jewelers' Supplies, Watches, Jewelry, etc. Illustrated catalogue and price list sent on application and receipt of card.

- Matson, N. & Co.**—Importing and Wholesale Jewelers. 166, 168 and 170 State Street, Chicago, Ills.
- Norris, B. F. & Co.**—Wholesale Jewelers, and Dealers in Watchmakers' and Jewelers' Supplies. 101 and 103 State Street.
- Perry Bros.**—Wholesale Dealers in Watches, Jewelry, etc. N. E. corner State and Monroe Sts. Chicago, Ills.
- Rosenkrans & Weber**—182 State Street. Jobbers of Watches, Jewelry, and all Jewelers' Supplies.
- Solomon, Weinberg & Co.**—Jobbers of Watches, Fine Jewelry and Diamonds, also Importers of Optical goods. No. 150 State Street, Chicago, Ills.
- Stein & Ellbogen**—Wholesale Dealers in Watches and Jewelry, 127 State Street, Chicago, Ill. Specialty, repairing for the trade.
- Wathier, Joseph P.**—Watchmakers and Jewelers for the trade, and Wholesale Dealers in Watch Materials, Tools, etc. 178 West Madison Street, Chicago, Ill. Send for price list.
- Weich, E. N. Mfg. Co.**—6 Warren Street, New York, E. C. Hine, Treasurer and General Manager, 69 Washington Street, Chicago. F. E. Morse, Agt.
- Wendell, Charles & Son**—Wholesale Watches, Jewelry, etc. 170 State street, Chicago.

NEWARK.

- Alling, Isaac A. & Co.**—Manufacturers of Diamond and Fine Gold Jewelry, Sets, Lace Pins, Ear Rings, Studs, Rings and Buttons. Specialties: Wire Bracelets, Bangles and Scarf Pins. 50 Walnut Street, Newark.
- Baker & Co.**—Gold and Silver Refiners, Assayers and Sweep Smelters. 104 New Jersey Railroad Avenue, near Green St., Newark, N. J.
- Block & Bergfels.**—Manufacturing Jewelers. Novelties in Fancy Diamond and Pearl Rings and Knife Edge Lace Pins. Patentees of Pearl Setting without clamps. 336 Mulberry St., Newark.
- Diefenthaler Bros. & O'Donnell**—Manufacturers of Fine Jewelry, Lace Pins, Ear Rings and Patent Spring Bangles a Specialty. 36 Crawford Street, Newark, N. J.
- Fiedler, Herrman**—Successor to Kurze & Fiedler, Engraver, Die Sinker and Press Tool Maker, 363 Market Street, Opposite Pennsylvania R. R. Depot, Newark, N. J.
- Herpers Bros.**—Manufacturers of Settings, etc. 18 Crawford Street, Newark, N. J.
- Hopper & Valentine**—Manufacturers of Fine Jewelry, No. 8 Maple Place, Rear 44 Green St., Newark, N. J.
- Hüger & Heitlinger.**—Manufacturers to the Jobbing Trade only. Makers of Sets, Lace Pins and Ear Rings, Locketts a specialty. 477 Washington Street, Newark, N. J.
- Krippendorf, C. & Schuller, F.**—Machinists and Jewelers' Tool Makers. 19 Greene Street, Newark, N. J. Rolls, Dies, Cutters, and Draw-plates of every Description made and repaired.
- Lefort, Henry.**—Stem-winding Watch Crown Manufacturer. 60 Arlington Street.
- Lelong, L. & Bro.**—Gold and Silver Refiners Assayers and Sweep Smelters, Southwest corner of Halsey and Marshall Streets, Newark, N. J.
- Miller & Beam.**—Manufacturers of Enamelled Sets, Ear Rings, Lace Pins, etc. Guard Slides and Pendants a Specialty. 21 and 23 Green Street.
- Milne, Alex.**—Manufacturer of Stem-winding Watch Crowns. 19 Ward Street.
- Newark Steam Lapidary.**—Maple Place, Rear 46 Green Street, Newark, N. J. Re-cutting of all kinds of Precious and Imitation Stones, Locket Glasses, etc. Flush work of all kinds a specialty. J. Pollitt, Manager.
- Pollock, T. H.**—Manufacturer of Jewelers' and Silversmiths' Wheel Brushes, Buffs, etc. No. 36 Crawford Street, Newark, N. J.
- Regad, E. D.**—Lapidary. Specialty—Sardonyx, Black Onyx and Agates. 14 Oliver St., Newark.
- Stadmeyer & Felger**—Manufacturing Jewelers. Specialties:—Roman Band Bracelets, Bangles, Lace Pins, Scarf Pins, Ball and Fancy Ear Rings. No. 477 Washington Street, Newark, N. J.

PROVIDENCE

- Irons, Chas. F.**—Manufacturer of Solid Gold Jewelry. Specialty, Emblems, Pins and Charms, Masonic, Odd Fellows, etc. 102 Friendship St.
- Lederer, S. & B.**—Manufacturers of Fire Gilt, Nickel, Electro and Silver Plated Chains, Necklaces, Charms, etc. Opera, Matinee and Guard Chains. 66 to 72 Stewart St., Providence, R. I.
- Smith, Wm. T.**—Assayer, Refiner and Sweep Smelter. Established 1855. Blackstone and Hawkins Streets, Providence, R. I.
- Taylor, Geo. H. & Co.**—Watchmakers and Wholesale Dealers in Watches, Clocks, Watch and Clock Material, Tools, Spectacles, Eye Glasses, &c. Particular attention given to trade work. 136 Westminster Street (Room 1), Providence, R. I.

PAWTUCKET.

- Draper, J. O. & Co.**—Manufacturers of Jewelers' Fig Soap, adapted for Washing Jewelry, Scratch Brushing and Drawing Wire. Pawtucket, R. I.
- Fuller, Geo. H. & Son**—Jewelers' Findings, Gold, Silver, Gold Plated and Fire Gilt. Pin Stems, Joints, Catches, Split Rings, Chain Hooks and Swivels, Ear Wires, Chain Bars, etc. 99 Exchange Street, Pawtucket, R. I.
- Thayer, Ellis & Son**—Brush Manufacturers, and Wholesale Dealers in all kinds of Brushes. Sole manufacturers of Ellis Thayer's Patent Polishing Wheels. Manufacturing Jewelers' and Machine Brushes a Specialty. 80 North Main Street, Pawtucket, R. I.
- Thayer, P. E. & Co.**—Manufacturers of Brushes. Jewelry and Machine Brushes a Specialty. All kinds of Wire Scratch Brushes on hand. Orders by mail or otherwise promptly attended to. 34 East Avenue, Pawtucket, R. I.

CINCINNATI.

- Awalt, John A.**—Jobber in Watches, Clocks, Jewelry, etc., 173 Vine Street, Cincinnati.
- Duhme & Co.**—Goldsmiths, Silversmiths and Diamond Setters. 4th and Walnut Streets, Cincinnati, Ohio.
- Lodwick & Nolting**—Wholesale Jewelers, S. W. cor. 4th & Walnut Streets, Cincinnati.
- Noterman & Jonas**—Manufacturing Jewelers, cor. 4th and Main Streets. Manufacturers of the Ophir Diamond Jewelry.

BOSTON.

- Boyce & Wainwright**—Manufacturers of Solid Gold Jewelry. Rings a Specialty. 383 Washington Street, Boston, Mass.
- Smith, Wm. A.**—Importer of Diamonds and Precious Stones. Diamonds mounted and unmounted and Diamond Mountings. 383 Washington St., Boston, Mass.

SPRINGFIELD.

- Bullock, O. W.**—Springfield, Mass. Manufacturer of Fine Nickel Plated Watch and Jeweling Tools, Keys, and Light Metallic Goods.

NORTH ATTLEBORO.

- Whiting, F. M. & Co.**—Manufacturers of Sterling Silver Ware and Jewelry, North Attleboro, Mass.

LANCASTER.

- Bowman, E. F.**—Jobber in Watches, Clocks, Chains, Fine Tools and Materials. 20 East Chestnut Street, Lancaster, Pa.

PITTSBURGH.

- Goddard, Hill & Co.**—Wholesale Dealers in American Watches, Jewelry, Silverware, Clocks, Materials, &c., 43 Fifth Avenue, Pittsburgh, Pa.

BALTIMORE.

- Morris, Wm. & Co.**—Importers and Jobbers of Watch Materials, Tools, Optical Goods, Plated and White Metal Chains. Agents for American Lathes, &c. The attention of Southern Trade is requested. 207 and 209 West Baltimore Street.

CANADA.

- Ellis, P. W. & Co.**, No. 31 King street, East Toronto, Ontario, Manufacturing Jewelers, Watchmakers, importers and Jobbers of Watchmakers, and Jewelers' Tools, Materials, General Supplies and American Jewelry. Correspondence solicited with manufacturers of Novelties or specialties in American Tools and Jewelry.

POSITIVELY NO GOODS RETAILED.

BOWMAN & MUSSER,

SUCCESSORS TO

E. F. BOWMAN,

JOBBERS IN

Watches, Clocks, Chains,

Fine Tools and Materials,

20 E. CHESTNUT STREET,

Cpp. P. R. R. Passenger Depot,

LANCASTER, PA.

Selection Packages sent to Regular Jewelers on Request.

BARNES'

No. 4 LATHE,

For the Heavier Work of Jewelers.

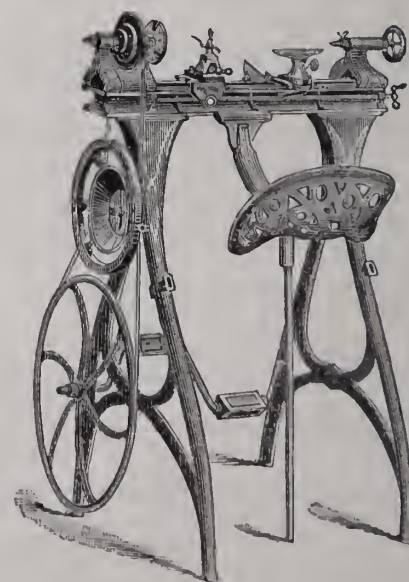

Barnes' Patent Foot and Steam Power Machinery. Complete outfits for Actual Workshop Business. Lathes for wood or metal. Circular Saws, Scroll Saws, Formers, Mortisers, Tenoners, etc., etc. Machines on trial if desired. Descriptive Catalogue and Price List Free.

W. F. & JOHN BARNES,

2088 Main Street, ROCKFORD, ILL.



Standard Marine Chronometer
FOR KEEPING CORRECT TIME.

JOHN BLISS & CO.,
Standard Marine
CHRONOMETERS AND TRANSITS
FOR WATCHMAKERS' USE.

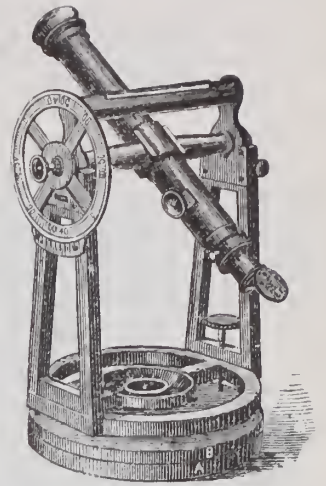

No. 10

128 FRONT STREET, NEAR WALL STREET, NEW YORK.

IMPORTANT NOTICE.—These Transits are readily set in position without the aid of strictly correct time as a basis for that purpose. Printed instructions, easily understood, accompany each Instrument, and no calculations are required preliminary to setting in position.

As a trial only is required to insure unqualified approval, we are induced to make the following **LIBERAL OFFER**—On receipt by us of satisfactory reference, and 10 per cent. of the price, we will send one of the foregoing Transit Instruments, on hire or trial, for one month, with full printed instructions for setting up and using the same, and if purchased after trial, we will allow the whole hire to apply in part payment, and sell the Instrument on approved note at four months for the balance. Special terms for payment by installments, after trial, on application. We do not make this offer merely to hire these instruments, but to insure a trial with a view to sales, the hire received being only sufficient to cover the cost of repolishing in case they are returned. Send for Illustrated Circular giving full description.

JOHN BLISS & CO., 128 Front Street, (between Wall and Pine Sts.) New York.

THE
Jewelers' Circular & Horological Review.

THE RECOGNIZED ORGAN OF THE TRADE.

Published Monthly, at - - \$2.00 per Annum.

D. H. HOPKINSON,

Editor and Proprietor.

42 NASSAU STREET, N. Y.

Volume XIV commences with this issue.

L. W. LEVY.

ED. DREYFUS.

PHILIP HECHT.

LEVY, DREYFUS & CO.,

No. 11 MAIDEN LANE,

P. O. Box 3567,

NEW YORK.

Exporters, Importers and Manufacturers.

Watchmakers' Fine Lathes and General Supplies. Imperial Spectacles and Eye-Glasses. Crescent Opera Glasses and Marine Glasses, Telescopes, Thermometers, Compasses, Microscopes, Drawing Instruments, and Optical Goods Generally.

ILLUSTRATED CATALOGUE MAILED TO ANY ADDRESS ON RECEIPT OF BUSINESS CARD.

MONOGRAM ALBUMS, \$5 & \$10 EACH.

SOLE AGENTS FOR THE MOST COMPLETE BOOK OF

COMBINATION MONOGRAMS

OF 3 and 4 LETTERS,

OF THE LATEST DESIGNS,

PRICE, - - - \$10.

One of 2 Letters and 35 Series of Alphabets, \$5.



PATENT IMPROVEMENT

— IN —

COUNTER SHOW CASES



WITH

PERPENDICULAR SLIDING DOORS.

DUST

PROOF.

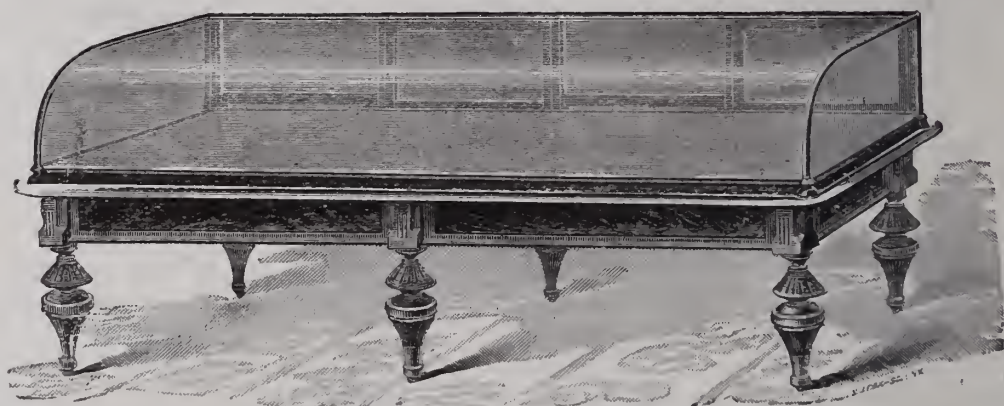

The Advantage and Convenience of these Show Cases will be apparent to everyone.

The doors are more conveniently opened and closed, less liable to get out of repair or broken, articles are more easily reached in wide cases, mirrors are more safe, it dispenses with hinges, economizes room, excludes dust, and is air tight when closed.

Drawings furnished and estimates given for fitting stores in cabinet work complete.

Letters Patent having been granted us for the construction of these doors, we shall prosecute all parties using Cases which infringe on our Patents.

REFERENCES:—Gorham Mfg Co., Rogers & Bro., Mitchell Vance & Co.,
Meriden Britannia Co., M. S. Smith & Co. Detroit, Mich.
D. Valentine, Syracuse, N. Y.

B. & W. B. SMITH,
220 West 29th Street, New York.

M. Anderson, No. 57 State Street, Chicago, has the exclusive right to manufacture and sell our Improved Cases for the States of Wisconsin, Illinois, Missouri, Mississippi, Arkansas, and all States West of same.

CATALOGUE OF STYLES SENT ON APPLICATION.

WATERBURY CLOCK CO.,

MANUFACTURERS OF

CLOCKS,

Novelties and Materials,

No. 10 CORTLANDT ST., N. Y.

— AND —

No. 63 WASHINGTON ST., CHICAGO.

Factories, **WATERBURY, CONN.**

M. BAILEY, Treasurer.

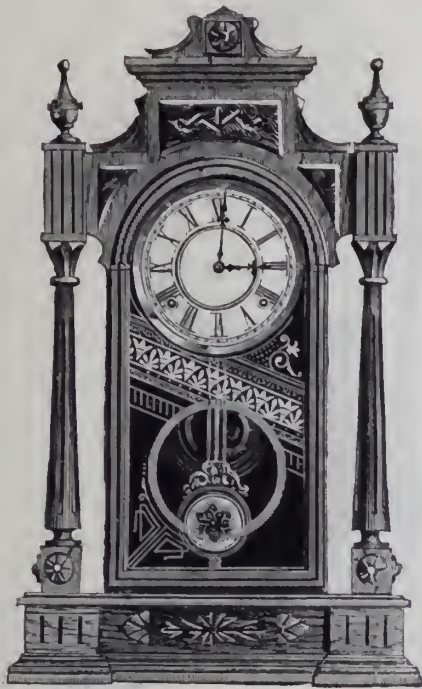

RAPIDAN.

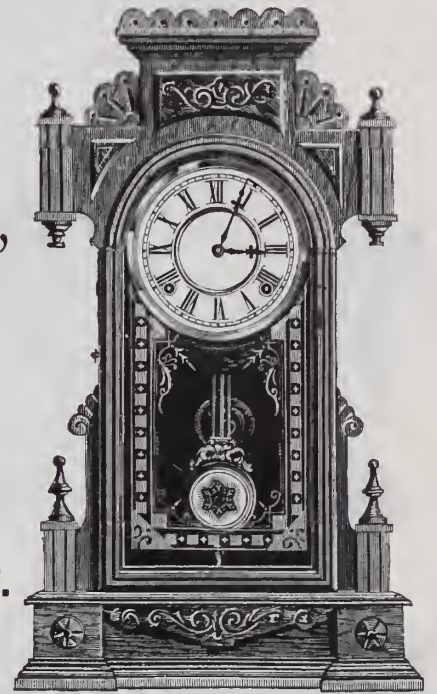

DUNKIRK.

The Ansonia Clock Co.,

- Mantel Clocks.
- Office Clocks.
- Regulators.
- Pillar Clocks.
- Tower Clocks.

BRONZES.

- Nickel Clocks.
- Wood Clocks.
- Iron Clocks.
- Plush Clocks.
- Marble Clocks.

CHICAGO,
64 Washington St.



"No. 8 MARBLEITE."

8-Day, Visible Escapement, Half-Hour Strike, Cathedral Gong, Back-Action Attachment.

NEW YORK,
11 to 19 Cliff Street.

MARBLEITE CLOCKS,

Richer in Appearance and
More Durable than
Black Marble.

The Natural Polish of the Material
Produces the Most Beautiful
Jet Black Surface.

IN A
VARIETY OF STYLES.

LONDON,
128 Minories.

W. L. GILBERT CLOCK CO.,

GEORGE B. OWEN, General Manager.



LEBANON.—Walnut.
8 Day Strike.
Height 20½ inches. 6 inch Dial.

Salesrooms:
No. 6 Murray St., N. Y.
54 & 56 Madison St., Chicago.

Factories:
WINSTED,
Conn.

MANUFACTURERS OF
Walnut, Veneered and Other Clocks

IMPORTERS OF
Marble and Cuckoo Clocks.



ENID.—Walnut.
One Day Strike.
Height, 21½ inches. 6 inch Dial.

Catalogue and Price List Furnished upon application.

E. N. WELCH MFG'G CO.

AND WELCH, SPRING & CO.

MANUFACTURERS OF

CLOCKS, REGULATORS, PERPETUAL CALENDARS.

6 Warren St., New York,

NO. 2 REGULATOR

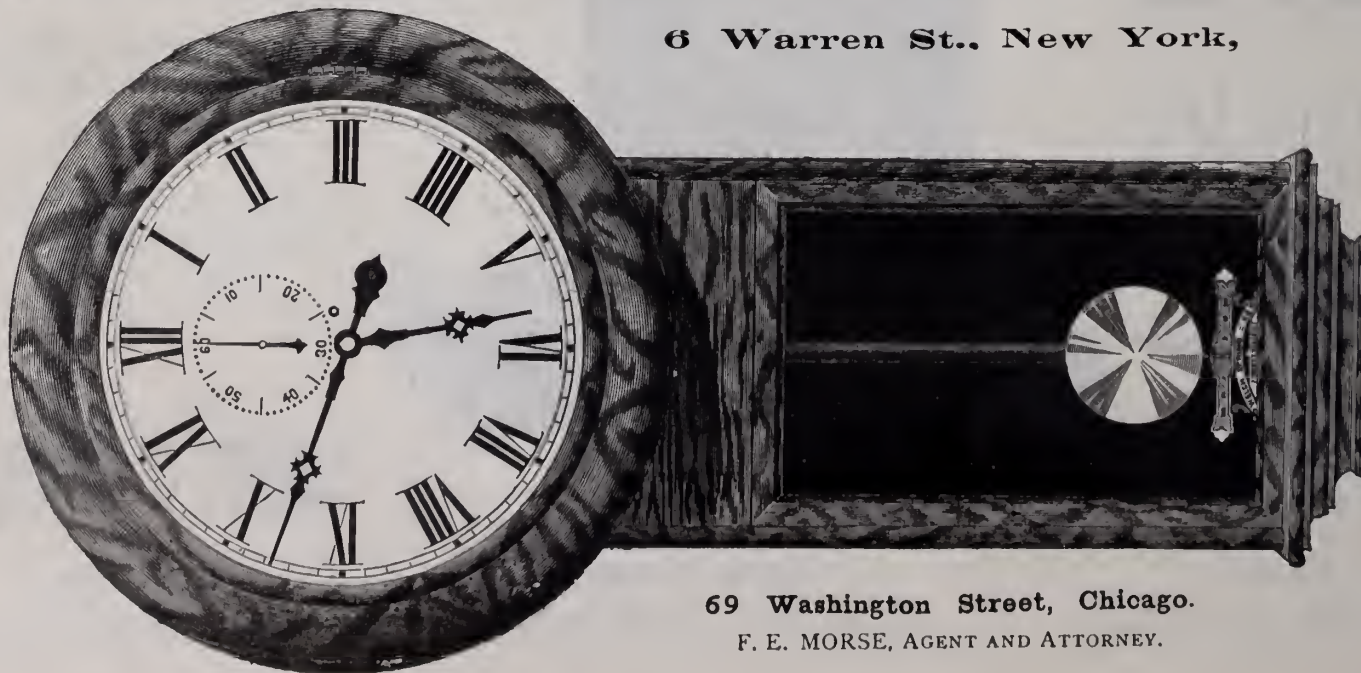

69 Washington Street, Chicago.
F. E. MORSE, AGENT AND ATTORNEY.

Height, 53 inches. 18 inch Dial. 8 day. Weight. Time.

"THE SARATOGA."—Patented.



—: MADE BY :—

ROGERS & BROTHER,
 690 BROADWAY, NEW YORK.
 WORKS, WATERBURY, CONN.

NICHOLAS MULLER'S SONS,
 MANUFACTURERS OF

CLOCKS AND BRONZES,



PATENT REGULATOR.

The above cut explains itself. Our New Regulating Attachment is so simple that a child will readily understand it. No small key needed. No stopping or moving of clock to regulate it.

117 Chambers St.,
 New York.

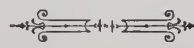

Novelties and Fancy
 Goods for the
 Jewelry Trade.



"CORINTH."

8 Day, 1/2 Hour Strike, Visible Escapement,
 Ruby Pallets.

LOUIS STRASBURGER & CO.

DIRECT IMPORTERS OF

WATCHES AND DIAMONDS,

WE MAKE EVERY KIND
OF WATCH IN
OUR OWN
FACTORY.

WE GET THE ROUGH
DIRECT AND CUT
OUR OWN
GOODS.

No. 15 MAIDEN LANE,

→ NEW YORK ←

Rue Leopold Robert,
CHAUX-DE-FONDS.

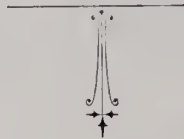

Boulevard Haussman, 30,
PARIS.

SPRING SEASON, 1883.
NEW DESIGNS NOW READY.

MIDDLETOWN



PLATE CO.

MANUFACTURERS OF

Superior Silver-Plated Ware.

In Tea Sets, Waiters, Berry Dishes, Baskets, Toilet Sets, Jewel Boxes, Presentation Goods, Epergnes, &c., of the Very Best Quality. Also Pitchers, Pitcher Sets, Swing Sets, Etc.

EVERY VARIETY OF HOLLOW AND FLAT WARE.

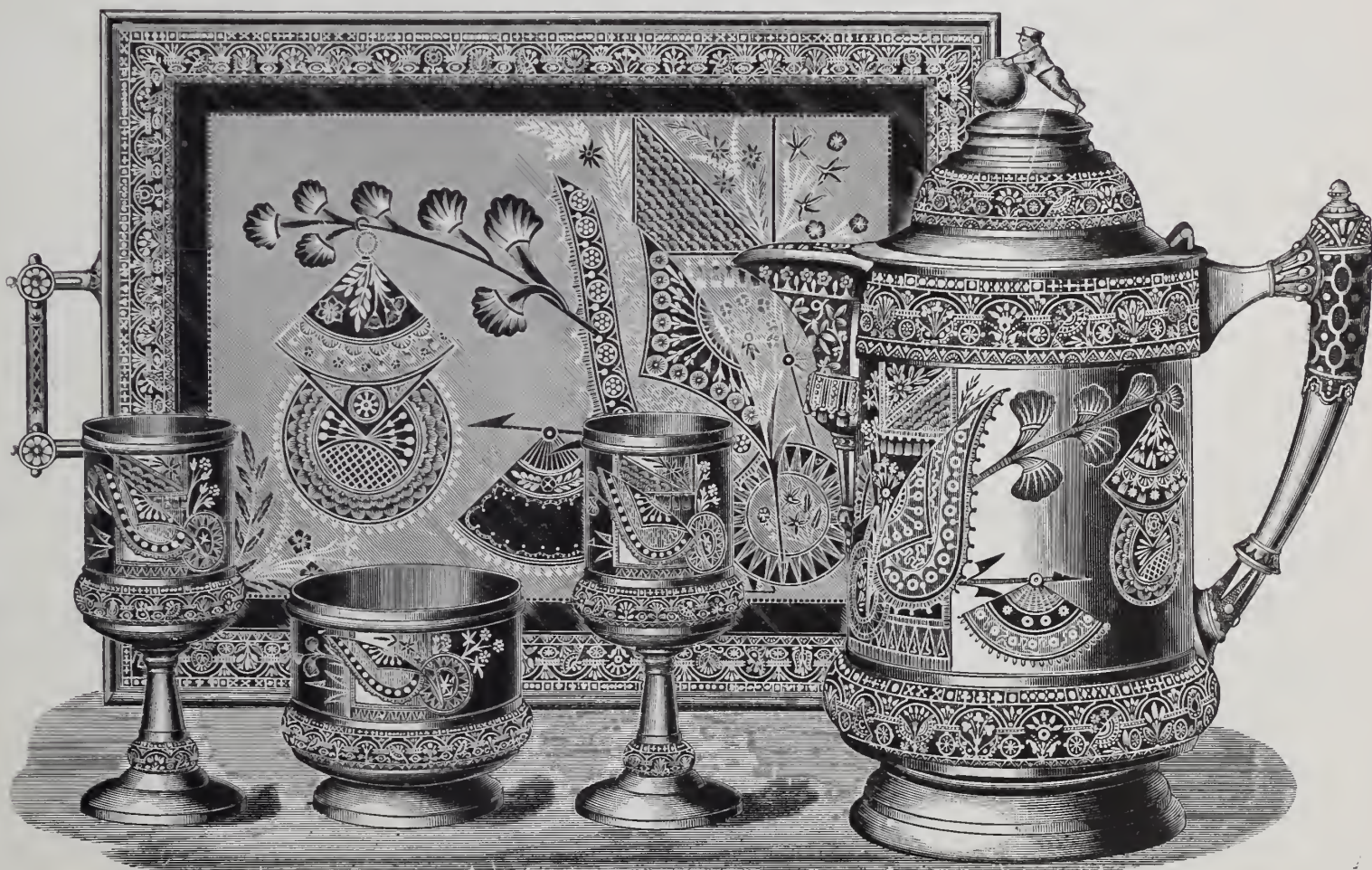

OFFICES.

*Middletown, Conn.,
120 Sutter Street, San Francisco, Cal.*

*13 John Street, New York,
101 & 103 State Street, Chicago, Illinois.*

Illustrated Catalogues and Photograph Albums sent to responsible Dealers.

JOSEPH FAHYS & CO.,
 MANUFACTURERS OF
 WATCH CASES,
 38 MAIDEN LANE,

78 Monroe Street, Chicago.

NEW YORK.

Attention is directed to the increased facilities introduced in our Factories for the manufacture of Watch Cases, and the superior class of goods we are now making. It is not too much to say that we are now producing the largest and most complete line of Silver Watch Cases in the country, and that for style, quality, workmanship and finish are not excelled by any other makers.



All cases of our manufacture are stamped with a fac-simile of this Trade Mark.

These goods are offered at a much lower price than any other cases sold in this market.

New styles and designs constantly appearing.

A Full Line of Cases always in Stock.

JOSEPH FAHYS & CO.,
 38 MAIDEN LANE, N. Y.

FOR SALE BY ALL THE LEADING JOBBERS IN THE COUNTRY.

—:o T H E o:—

BROOKLYN :: WATCH :: CASE :: CO.'S EAGLE CASE.

The name was first used by this company seven years ago, to designate a case that was full 8-k. in all its parts, no piece, bearing, or joint, being used that was not full 8-k., or that would not stand the test of pure Nitric Acid without showing green. The Backs and Cap are absolutely free from solder, excepting what holds the joints. This Case has gradually won its way in the Trade, until its Standard of Quality is admitted to be just as reliable as that of gold dollars. To those who are disposed to investigate, it can be shown that no gold of less standard than 12-k. can compare at all favorably with the wearing properties of the

→* "B. W. C. CO.'S EAGLE CASE," *←

and cases can be shown that have been in use since 1875, which compare favorably with 14-k.; it is the Best Case ever offered the Trade for the money. All of these goods are stamped in the Cap with the trade mark (B. W. C. Co.) of the Company.

Any 8-k. red or yellow gold, except our Eagle quality, will not stand the acid test, and when kept in safe or show case will soon discolor, and when carried in the pocket will turn black.

This Company always has in stock the largest assortment in 18-k., 14-k., and Eagle Cases, of the latest designs and most desirable styles.

FOR SALE BY ALL THE PRINCIPAL JOBBERS.

DAVID F. CONOVER & CO.

(SUCCESSORS TO WM. B. WARNE & Co.)

Manufacturers and Wholesale Dealers in

WATCHES and JEWELRY.

Wholesale Agents For

Rogers & Brother's Flat and Hollow Ware



Celluloid Eye-Glasses.

And Sole Agents for the

Patent Railroad Train Watch Chains, Nickel.

WHOLESALE AGENTS FOR

T. A. WILLSON & CO.'S Optical Goods.

Would invite attention to the following new grades of Steel Spectacles lately introduced in the market.

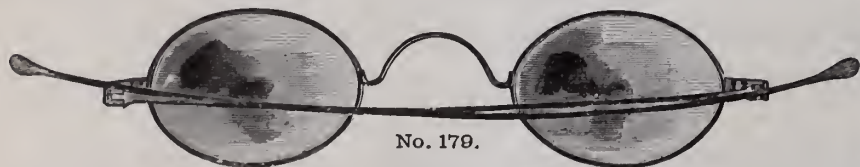

No. 179.

They are Steel, Full Tempered. Parts Interchangeable. Joints so constructed that wear is compensated for. Temple will not work loose and fall down as in old style joints. Nose-piece on No. 155 reinforced where it joins eye, giving extra strength with neatness.

PRIZE MEDALS AT ALL EXHIBITIONS WHERE EXHIBITED.

Patented July 31, 1877.

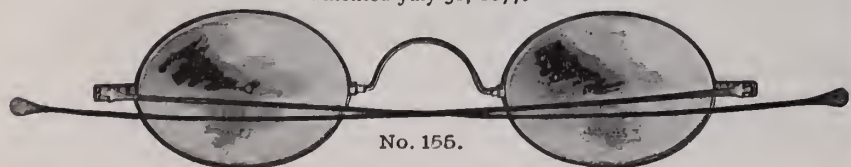

No. 155.

American Watch Wholesale Salesroom:

Southeast Cor. Chestnut and Seventh Sts., First Floor,

DAVID F. CONOVER,
C. FRANK WILLIAMS
B. EDGAR RIGHTER.

PHILADELPHIA.

A SPECTACLE TEMPLE

THAT WILL

NOT WEAR LOOSE.

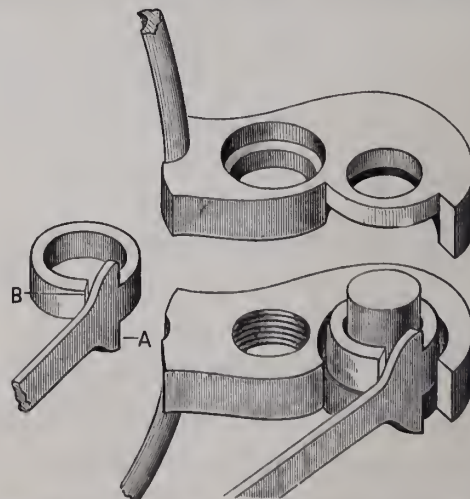

Patented May 13th, 1879. Re-issued June 8th, 1880.

A.—Stop for Temple, preventing Strain on Joint.

B.—Compensating eye, for taking up wear of joint. The eye of Temple is smaller than Stubb Steel Joint Pin on which it works, and is left open at B, exerting a Spring Tension on Pin.

TAYLOR & BROTHER,
676 BROADWAY, NEW YORK.
IMPORTERS OF
Diamonds and other Precious Stones,
Clocks, Bronzes and Fancy Goods,
AND
MANUFACTURERS OF DIAMOND JEWELRY.

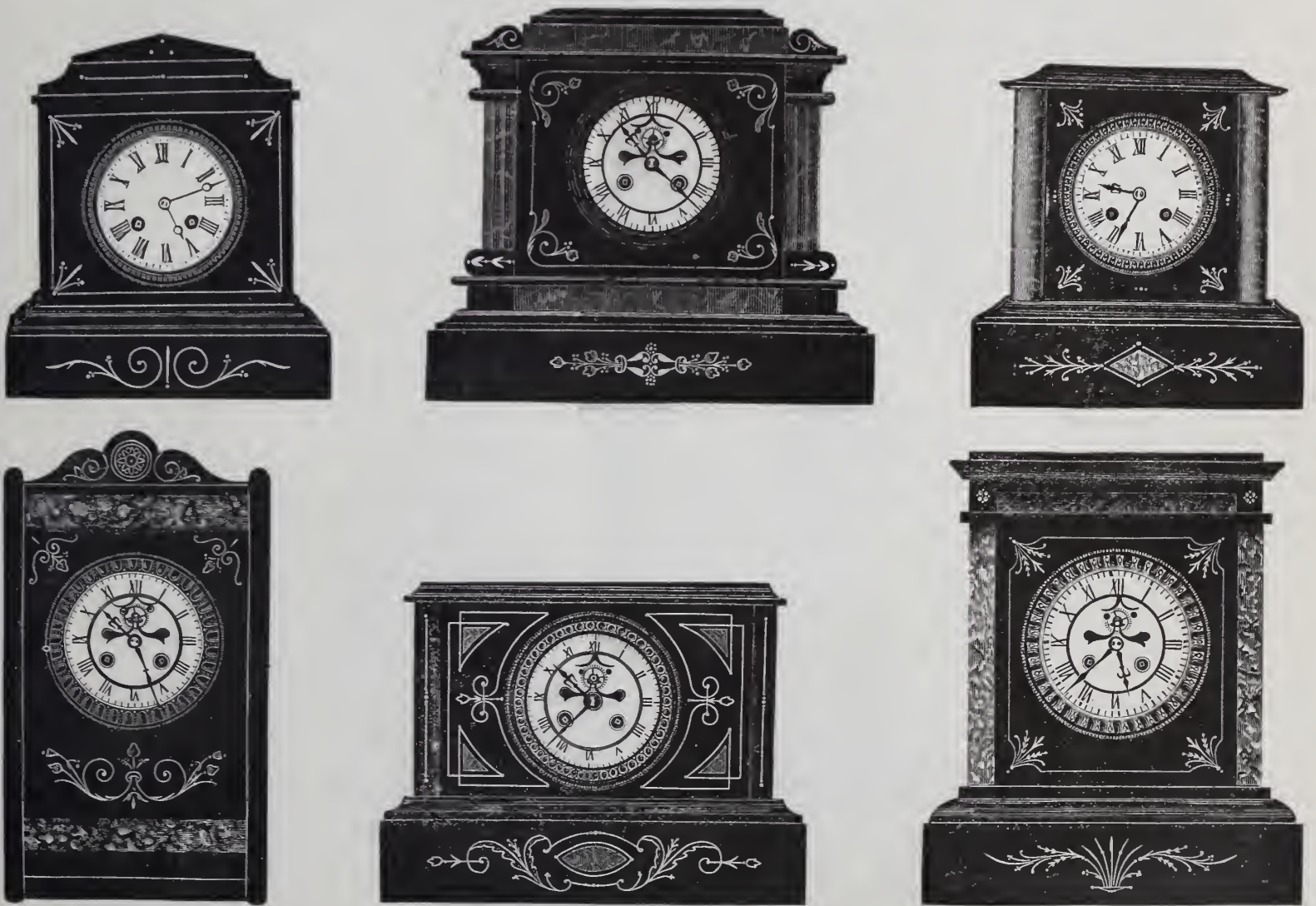

*Especial attention is directed to our Recent Invoices of FRENCH CLOCKS,
Sold at EXTREMELY LOW PRICES.*

ORIGINAL PACKAGES OF DIAMONDS CONSTANTLY ARRIVING,

THE BEST THE DUEBER



WATCH CASE

A WATCH CASE

As Good and as Perfect as

THE DUEBER WATCH CASE

Must be made in the same identical way we make them.



The Dieber Watch Case Manufacturing Co.,

NEW YORK

CINCINNATI

CHICAGO

SIMPSON, HALL, MILLER & CO.,

WALLINGFORD, CONN.

MANUFACTURERS OF

ARTISTIC & USEFUL HOLLOW WARE,

⇒: **ELECTRO PLATED UPON FINE HARD WHITE METAL.** ⇐:



Spoons, Forks, etc., plated upon the Finest Nickel Silver in **Extra Double, Triple, and Sectional Plates.** Full lines of over **Forty Staple and Fancy Pieces** in each Pattern in Geneva, St. James, Countess, Windsor, Oval Thread, etc. Made under the supervision, and quality guaranteed and controlled by Wm. Rogers, formerly of Hartford and Meriden. (Wm. Rogers, Sr., died 1873).

WM. ROGERS, Wallingford, Conn.

No connection with any concern in Waterbury, Meriden or Hartford using name of Rogers in any form.

Store and Stock of Goods for Delivery in N. Y. and Vicinity,

No. 36 East Fourteenth Street, Union Square.

Philadelphia, 506 Commerce St.—San Francisco, Cal., 530 Market St.

Montreal, Canada.—Baltimore, 6 German St.

JOBBER IN CINCINNATI, CHICAGO, ST. LOUIS, Etc.

BROWN & BROTHERS,

Finest Silver Plated Flat Ware,

SPRING TEMPERED SHANK. NEW AND CHOICE PATTERNS.



“FLORAL.”

We guarantee all our goods to be made of full quality 18 per cent. Nickel Silver, and weight of plate to be as indicated on the labels.

GOODS PACKED ONE DOZEN IN EACH BOX.

Factories, Waterbury, Conn.

Salesroom, 80 & 82 Chambers Street, N. Y.

HOLMES, BOOTH & HAYDENS,

MANUFACTURERS OF

Electro-Silver Plated Spoons, Forks, Ladles, Fancy Pieces, Solid Handle Table Knives, Etc.,

OF THE FINEST QUALITY.

No. 49 CHAMBERS ST.,
NEW YORK.

No. 506 COMMERCE ST.,
PHILADELPHIA.
WORKS AT WATERBURY, CONN.

No. 18 FEDERAL ST.,
BOSTON.

The "Corona" Pattern.
NEW.



The "Corona" Pattern.
NEW.

The "Japanese" Pattern.

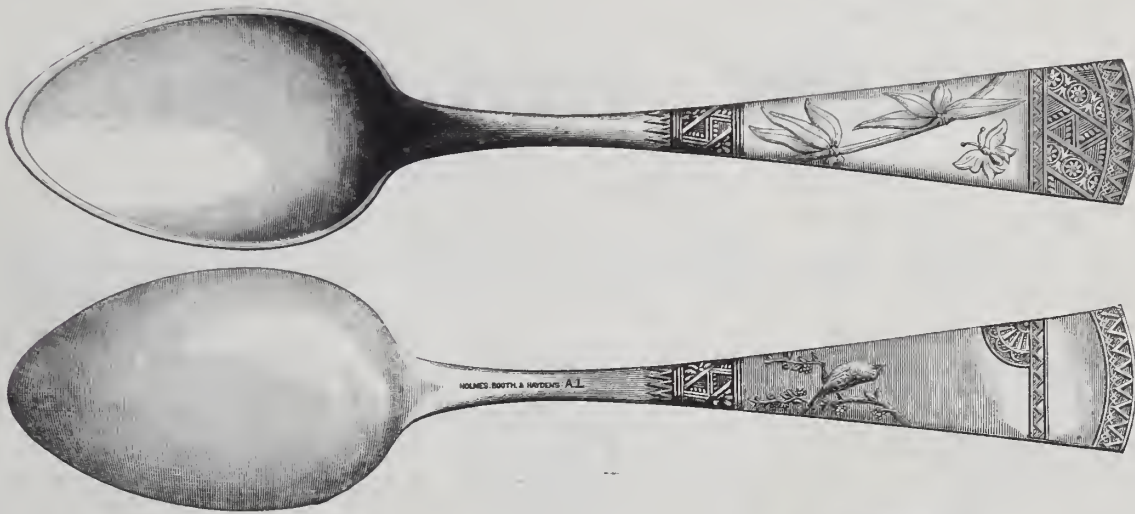

The "Japanese" Pattern.

The "India" Pattern.



The "India" Pattern.

WE GUARANTEE OUR GOODS TO BE FIRST-CLASS IN EVERY RESPECT.

THE
 DERBY SILVER CO.
 BIRMINGHAM, CONN.

MAKERS OF THE

BEST QUADRUPLE

PLATED WARE.

Illustrated Catalogues sent to Dealers upon Application.

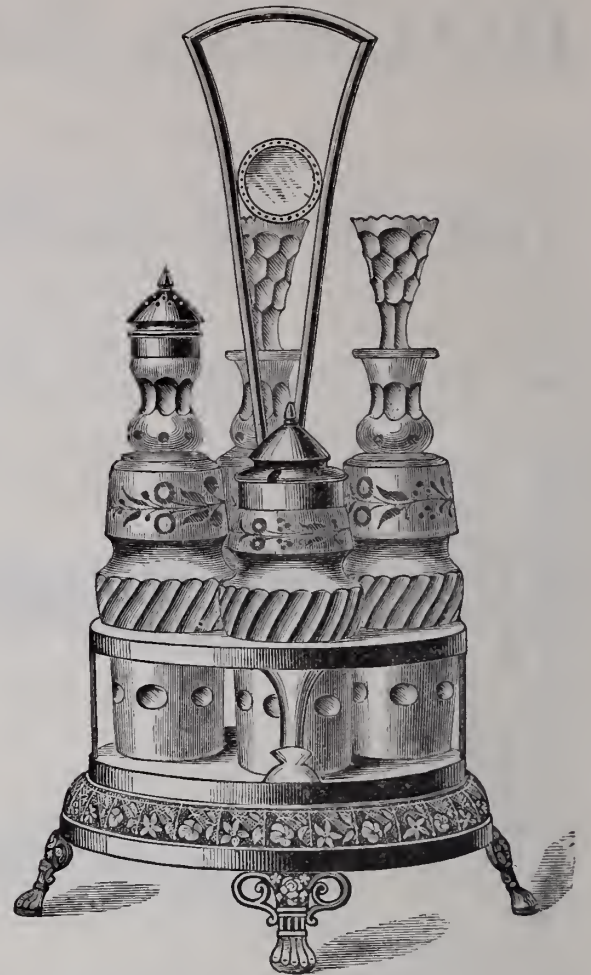

ADOLPH GOLDSMITH,

SOLE AGENT FOR THE

RELIANCE WATCH COMPANY,

38 MAIDEN LANE,

NEW YORK.

FULL LINE OF

Gold and Plated Jewelry.

EVERY DESCRIPTION OF

SWISS WATCHES

A SPECIALTY.



"RELIANCE,"
18 Size, to Fit Waltham Cases.



"RELIANCE,"
Nickel Stem Winder in all Sizes.



"RELIANCE,"
Ladies' 8 Size, to Fit Waltham Cases.

SIMONS, BROTHER & CO.

MANUFACTURERS.



TRADE MARK

CHAIN.



Fine Jewelry.

ILLUSTRATED CATALOGUE

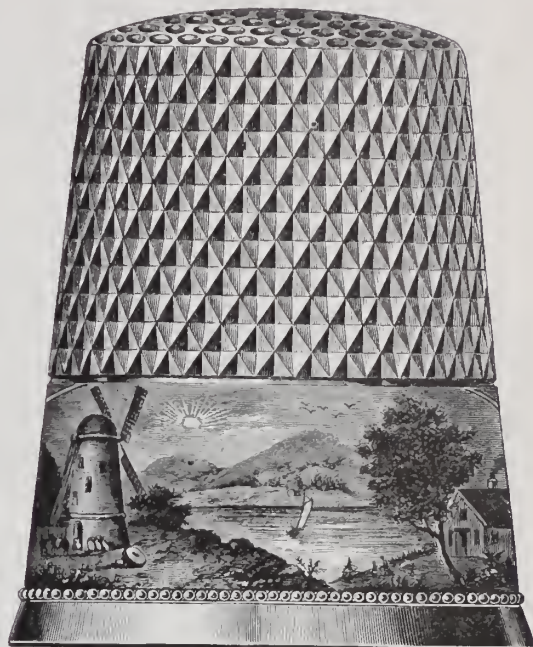

611 and 613 SANSOM STREET, PHILADELPHIA, OR NEAREST JOBBER.

ESTABLISHED 1845.

WILLIAM H. BALL,

Successor to BALL & BARNARD.

—MANUFACTURER OF—

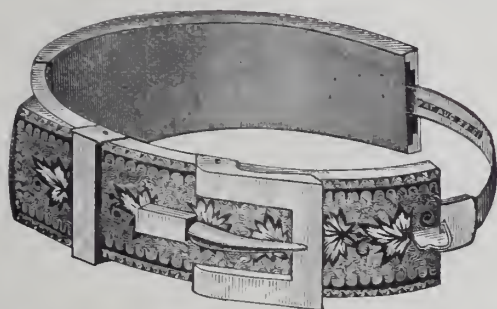

GOLD JEWELRY

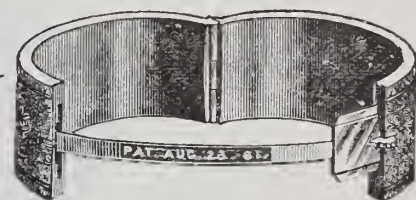

Specialty:—Bracelets,

Roman, Enameled and Engraved Band Bracelets, with the Safety Guard Attachment. THIS SAFETY GUARD is GUARANTEED and costs nothing additional.

ALSO A FULL LINE OF

Bangle, Braided and Padlock Bracelets.

Office, 9 JOHN ST.,

Factory, Newark, N. J.

NEW YORK.

Goods Sent on Selection to Responsible Parties.

FOR NEW METHOD OF CASE MAKING, SEE

Keystone Coin Silver Watch Cases.

A Jeweler having a large Railroad trade, says: "Your Full Bascine Beats the World, and the Keystone is the only Case that will not Spring in the Backs with hard use."

TO ILLUSTRATE:

FIG. 1.

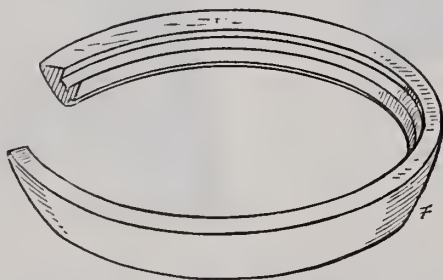

FIG. 1 Shows Bezel of Keystone Case, made from a Solid Piece of sheet Silver by swedging dies.

FIG. 2.

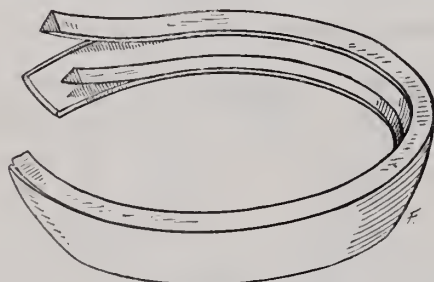

FIG. 2 Shows Bezel as commonly made with three pieces of Silver Soldered together.

FIG. 3.



FIG. 3 Shows Keystone Case brought to this state without a Particle of Solder, and composed of only Four pieces of Silver.

THE ADVANTAGES:

Increased Wear and Strength.

A Much Closer Fit.

Perfect Finish.

NOVELTIES IN AMERICAN × LEVER × BUTTONS

Follow each other in Rapid Succession.

The Manufacturers of these **Celebrated Goods** beg to announce to the Trade that they have Recently Introduced **Another New Initial Cuff Button**, which they have named the

ARABESQUE

→THE ALPHABET←

Of which the above letters are fac-similes, has been protected by **Design Patent**, and the Manufacturers have adopted the word itself as their **Trade-Mark** for this style of goods.

And all makers of Buttons are cautioned against infringing the same.

THE FAMOUS HORSE-SHOE AND CLOVER TRADE-MARK,
WHICH IS A GUARANTEE OF THE QUALITY, FINISH AND MECHANISM OF
AMERICAN LEVER GOODS,
WILL BE PRINTED UPON THE BUTTON CARDS.

Dealers are reminded that the Caps or Linings to the Shoes of **GENUINE AMERICAN LEVER BUTTONS** are made of **BRIGHT POLISHED ROLLED GOLD PLATE**.

ASK YOUR JOBBER FOR
THE AMERICAN LEVER ARABESQUE INITIAL.

ESTABLISHED 1847.

J. T. SCOTT & CO.,
 IMPORTERS, JOBBERS & MANUFACTURERS,
 No. 7 MAIDEN LANE, N. Y.

Would Respectfully Announce to the Trade that they this season offer a

LARGE AND ATTRACTIVE STOCK OF DESIRABLE JEWELRY,
 of the latest and newest designs, and suitable to the requirements of all classes of
 dealers. Our Stock embraces a Full Line of

Lace Pins, Ear Rings, Rings, Bracelets, Bangles, Gold and Plated Chain,
 in fact, everything in the Jewelry line. Also Sole Importers of the celebrated

TRIUMPH-ROSKOPF WATCH,

universally acknowledged by Competent Workmen to be *the best Watch for the
 money made.*

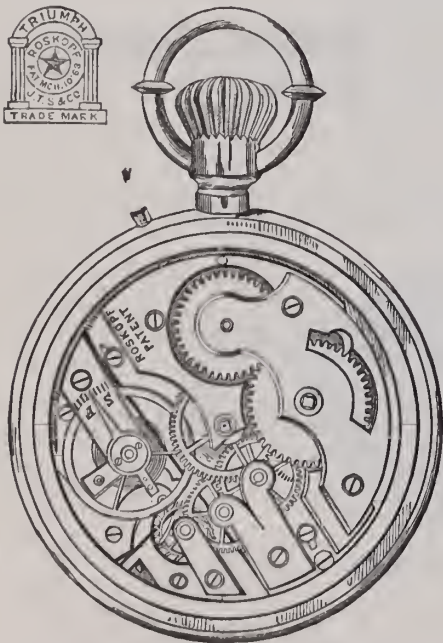

WITH INTERCHANGEABLE

AND ADJUSTABLE

ESCAPEMENT.

Cased in Superior Nickel, Open
 Faces, Stem Wind and Set.

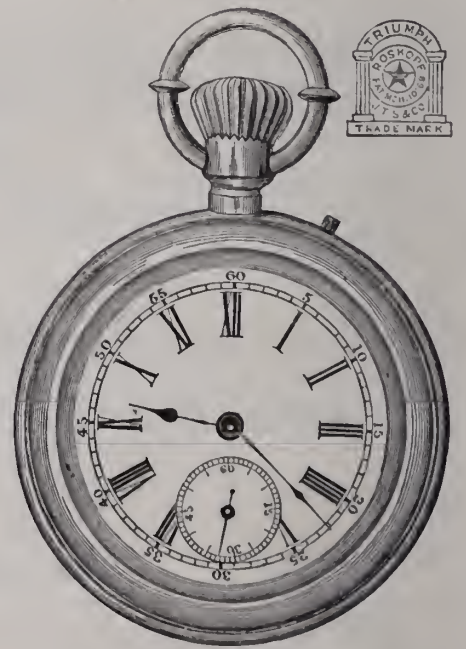
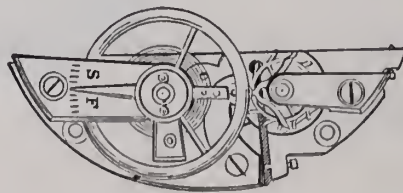

SOLE AGENTS OF THE OLD RELIABLE PATENT ROSKOPF WATCH.



A Full Line of American Movements and Cases.

All Orders committed to our care will Receive Prompt and Careful Attention.



Manufactory, 47, 49 & 51 Franklin Street, Newark, N. J.

MILLER BROS., JEWELERS,

7 MAIDEN LANE, NEW YORK.

SETS,
EAR RINGS,
CROSSES,
LOCKETS,
LACE PINS,
MEDALLIONS,

MOUNTED WITH

STUDS,
SCARF PINS,
COLLAR BUTTONS,
SCARF RINGS,
SLEEVE BUTTONS,
Etc., Etc., Etc.

Diamonds, Rubies, Sapphires, Pearls, Turquoise, Birds, Animal Heads and Fancy Ornamentations.

INITIAL GOODS A SPECIALTY.

All goods exclusively of our own manufacture, many of which are protected by MECHANICAL and DESIGN PATENTS:

CROSS & BEQUELIN,

21 MAIDEN LANE, N. Y.

IMPORTERS, MANUFACTURERS AND DEALERS IN

ALL GRADES OF WATCHES.

AGENTS FOR

CHAS. E. JACOT, J. ALFRED JURGENSEN

AND OTHER WELL-KNOWN SWISS MAKERS,

ALSO AGENTS FOR ALL AMERICAN WATCH COMPANIES.

Makers of the Centennial Watch, and Centennial Watch and Chronograph Combined; and the Centennial Calendar Watch.

A FULL LINE OF WATCH TOOLS, MATERIALS, ETC.

ROGERS & BROS.' Plated Ware.

OPERA GLASSES, JEWELRY, ETC.

SOLE AGENTS IN NEW YORK FOR THE SALE OF THE ENGLE ENGRAVING MACHINE.



WM. SMITH & CO.,

MANUFACTURERS OF

**GOLD and SILVER
Chains & Jewelry,**

Also a Large Line of SILVER RINGS.

OFFICE :

No. 25 Maiden Lane, New York.

MANUFACTORY—No 61 PECK STREET, PROVIDENCE, R. I.

W. & S. BLACKINTON,

MANUFACTURERS OF

ONLY

FINE ROLLED PLATE CHAINS,

Necklaces, Polished and Roman, of Latest Gold Designs. Also a Complete Line of Gents' and Ladies' Locketts and Pendants.

In consequence of the first-class reputation our goods have obtained, unscrupulous dealers have been selling goods of an inferior quality, represented as our manufacture. In order to protect ourselves, as well as dealers, all goods of our manufacture will hereafter bear this

TRADE MARK. **W&S.B** ★ TRADE MARK.*These Goods are for sale by all Wholesale Dealers.*

CHAS. P. HEROLD,
MANUFACTURING JEWELER,
DIAMOND SETTER
 AND DEALER IN
DIAMONDS.

916 CHESTNUT ST. PHILA.

N.B. A LARGE STOCK OF 18 KT. DIAMOND MOUNTINGS, SUCH AS CLUSTER AND SOLITAIRE RINGS, EARRINGS, LACE PINS, SHAWL PINS, CROSSES, STUDS, AND GENTS' PINS, &c. ALL OF WHICH ARE OF MY OWN DESIGNS, AND ARE MADE IN THE FINEST STYLE AND FINISH.

ESTABLISHED 1834.

FOR THE SPRING TRADE.

E. IRA RICHARDS & CO.,

MANUFACTURERS (Exclusively) OF

FINE ROLLED PLATED JEWELRY.

The Largest and Choicest Stock in the Country.

SPECIALTY FOR THE COMING SPRING,
BAND & BANGLE BRACELETS & Extra Quality ROLLED PLATED CHAINS.

These Vest Chains are produced to meet the demand for a

ROLLED PLATED CHAIN

that will wear for years. Each Chain bears the initial letters of our firm.

No. 200 BROADWAY, NEW YORK.
2d STORY, FRONT.

GOODS SENT ON SELECTION TO RESPONSIBLE PARTIES.

CHESTER MANCHESTER & CO.,

MANUFACTURERS OF

Gold & Silver Chains,**No. 13 HANOVER STREET,****PROVIDENCE, R. I.**Waltham, Elgin, Illinois,
 Hampden, E. Howard & Co.
 and Special Movements.**392 WASHINGTON ST.,**
BOSTON.

P. O. Box 5259.

Watches, Jewelry,
 Gold Chains, Gold,
 Filled and Silver Cases,
 Spectacles, Eye - Glasses,
 Gold Head Canes, and Rogers &
 Bro.'s Flat Ware.

Price List of Movements and Cases

Sent on Receipt of Business Card.

D. C. PERCIVAL & CO.,
WHOLESALE DEALERS.

ESTABLISHED 1837.

VICTOR BISHOP & CO.

IMPORTERS OF

DIAMONDS,

**Rubies, Sapphires,
Emeralds & Pearls.**

**Enamel Paintings, Roman Pearls,
Copper, Platinum and Iridium.**

33 MAIDEN LANE, NEW YORK.

House in Paris, 66 Boulevard de Sebastopol.

LOUIS A. SCHERR & CO.

Importers and Wholesale Dealers in

Watches, Jewelry,

WATCH MATERIALS, TOOLS, GLASSES, &c.

Spectacles, Silk Guards, &c.

Wholesale Agents for American Watches.

**No. 726 CHESTNUT STREET
PHILADELPHIA.**

AGENTS FOR THE WHITCOMB LATHE
AGENTS FOR W. F. NYE'S WATCH AND CLOCK OILS.

TO THE TRADE.

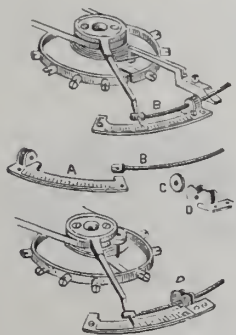

Your attention is called to the Improved Awalt Patent Watch Regulator, Style B. It is made of Nickel, Index and all combined, with Nut C and Screw B made of Fine Steel, to fit all full plate watches, by removing the Index and using the same screw holes and screws on the watch.

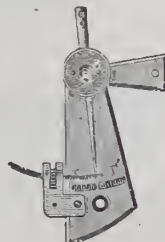

Style D Regulators have been improved in shape and finish, and fit both full plate and bridge watches, are made in Gilt and Nickel, with Nut C and Screw B of Fine Steel. Try them, and it will surprise you to find how much they will aid in making a watch realize you a nice profit.

JOHN A. AWALT, Manufacturer,

ALSO JOBBER IN

WATCHES, CLOCKS, JEWELRY, Etc.,

177 Vine Street,

CINCINNATI, OHIO.

Traitel Brothers, Gold Ring Manufacturers, will Remove, on or about March 10th, to their New Office, No. 40 Maiden Lane, New York.

JOHN W. STEELE,

MANUFACTURER OF

FINE GOLD JEWELRY,

—AND—

BRAINERD'S

PATENT

LOCKETS

Patented June 17, 1874.

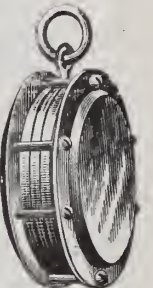

No. 9 Maiden Lane, NEW YORK.

MATERIALS
AND
OPTICAL GOODS.

Agents for the

LANCASTER, PA., WATCHES.

A. FRIEDENTHAL & CO.

Manufacturing Jewelers,

AND IMPORTERS OF

WATCHES,

43 MAIDEN LANE, NEW YORK.

THE BEST.
CELLULOID SHOW CASES.

REQUIRE NO CLEANING.

POLISH PERMANENT.

Send for Circular with Description, References, Testimonials,
 and List of Manufacturers.

CELLULOID SHOW CASE CO.,
 17 Maiden Lane, N. Y.

DAY & CLARK,
 —: MAKERS OF :—
FINE ROMAN GOODS,
BANGLES,
 Plain and Ornamented Bead Necklaces.
 Every style & size of Diamond Ear Ring Covers,
LACE PINS AND EAR DROPS.
STONE SEALS AND LOCKETS.
192 Broadway, cor. John Street,
FACTORY, NEWARK, N. J. NEW YORK.

OFFICE:
 14 JOHN STREET, NEW YORK.

E. STITES' SONS.

FACTORY:
 NEWARK, NEW JERSEY.

SUSSFELD, LORSCH & NORDLINGER,
 IMPORTERS OF
Optical & Mathematical Instruments,
 Watchmakers' Tools, Materials, Etc.

SPECIALTIES:

BARDOU & SONS' Universal Opera Glasses U. S. Army and Navy Glasses.
 Rifle Range Telescopes, Etc., Etc.

LA REINE Opera and Marine Glasses.

CROWN Spectacles and Eye-Glasses.

PARADIS MAINSPRINGS.

PARAGON TOOLS.

13 MAIDEN LANE, NEW YORK.

16 Rue D'Enghien, PARIS.

— 1883 —



New Goods in Novelties and Staple Lines.

—*LOW PRICES*—

AND ALL GOODS FULLY WARRANTED.

—*LUDWICK & NOLTING*—

Cincinnati's Exclusive Wholesale Jewelers.

DORRANCE, EDGE & CO.,

Sole Manufacturers of the Celebrated

Woven Fabric Gold Chain,

Elegantly Mounted Bracelets, OPERA, LEONTINE.

VICTORIA WATCH GUARDS AND NECKLACES
 In all the Newest Designs.

Our Stock is unusually complete, and in addition to the above a
 variety of NECKLACES, from 1½ to 40 dwts. each, to
 which we invite the attention of buyers.

CHILDREN'S BRACELETS A SPECIALTY.

No. 15 JOHN ST., NEW YORK.

FACTORY, 46 GREENE ST., NEWARK, N. J.

HELLER & BARDEL,

MANUFACTURERS OF

DIAMOND AND PEARL JEWELRY,

No. 13 John Street, New York.

A Novelty which we have introduced this season is

The Combination Ring, Lace Pin and Bracelet.

The advantages of this article of Jewelry will be readily appreciated, when taken into consideration that **One Piece of Jewelry** can be worn in three different forms.

R. WALLACE & SONS M'FG Co.,

MANUFACTURERS OF



SILVERWARE,

GUARANTEED $\frac{925}{1000}$ FINE.

WALLINGFORD, CONN.

H. P. HILDRETH,

MANUFACTURER OF

SOLID GOLD RINGS,

PLAIN AND ORNAMENTAL,

10 JOHN STREET, NEW YORK.

Factory, 1305 ATLANTIC AVENUE, Brooklyn.

Best Quality of Goods at Lowest Cash Prices.

Send for Price List, as I have no Agents.

COX & SEDGWICK,

26 JOHN STREET, N. Y.,

Makers of Patent Black Onyx Bracelets

Also Black Onyx Faceted Bead Bracelets,

AT THE LOWEST PRICES.

COLORED
AND

Turquoise

Lace Pins,
Ear Rings,
Lockets,
Bracelets,
Sleeve
Buttons,
Scarf Pins,

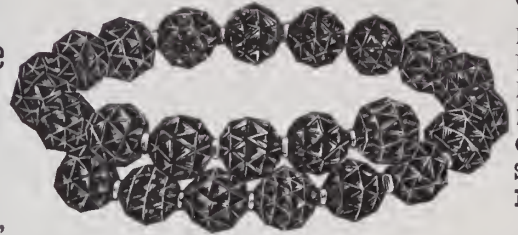

ONYX

Lace Pins,
Ear Rings,
Medallions,
Necklaces,
Chatelaines
Sleeve Buttons
Ladies & Gents
Vest and
Guard Chain.

Black Onyx Pins, Ear Rings and Lockets for 1, 3 and 5 Diamonds.

GOODS SENT ON APPROVAL TO RESPONSIBLE FIRMS.

WOOD & HUGHES,

STERLING

SILVERWARE MANUFACTURERS,

New York Agents for the Derby Silver Co.'s

Fine Quadruple Plated Ware,

No. 16 John Street, N. Y.

206 Kearney Street, San Francisco, Cal.

HASKELL & MUEGGE, Agents.

J. B. & S. M. KNOWLES,

MANUFACTURERS OF

Sterling Silver Ware,

No. 20 MAIDEN LANE,

NEW YORK.

FACTORY, PROVIDENCE, R. I.

GORHAM MFG COMPANY,

SILVERSMITHS,

37 UNION SQUARE, NEW YORK.

Factory, Providence, R. I.

Chicago Office, 170 State Street.

California Office, 120 Sutter Street, San Francisco.

SOLID SILVER.

HOLLOW WARE. In great variety, including Tea Sets, Dinner Ware, Epergnes, Fruit Sets, Pitchers, making the most complete assortment of Large Wares ever shown by one manufacturer.

SMALL WARES. Including Lunch Sets, Peppers, Salts in Pairs, and for Individual Use in Sets of 6 and 12, Butter Plates, Tea Bells, Card Trays, Olive Dishes, Bon Bon Dishes. Also a large assortment of Children's Wares. Among the latter will be found many specimens of the now famous Nursery Cups, Cup Sets, Bowls, and Complete Sets Handsomely Cased.

SPOONS AND FORKS. Our Latest Patterns in this line, the EMPRESS and the DOMESTIC have become successful to a remarkable degree, and we have recently added, for Spoons, Forks and Fancy Pieces, THE TUDOR, decorated by Hand Chasing, making a pattern very rich and elegant, suited to those desiring something superior to the ordinary stamped or rolled patterns. The prices for the Tudor will be found reasonable, when the decoration is considered.

CASES. We have given special care to the Casing of our Wares for the coming season, and as we have every possible facility for the manufacture of Cases, we are enabled to offer a superior article in this line to what is made by the ordinary case makers. We have, in this department, largely increased our facilities for the manufacture of Plate Chests and large Cabinets in Wood for Spoons and Forks.

GORHAM PLATE. We are constantly increasing this branch of our business, and our later patterns will be found very moderate in price when the quality is taken into consideration. We have entirely new designs in Tea and Dinner Ware, of entirely different character from what has heretofore been offered. Our line of Plated Spoons and Forks in the Old English, Roman, and Princess Louise Patterns are becoming very popular with the Trade and Public, and we offer them as a superior article to what has heretofore been made in this line.

ALFRED H. SMITH & CO.
IMPORTERS OF
DIAMONDS

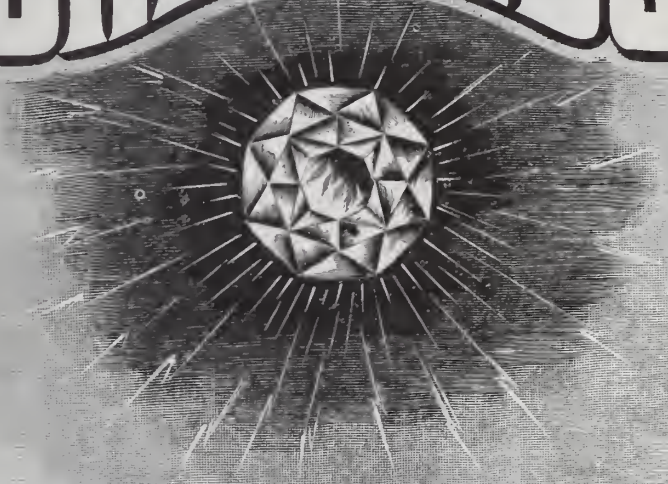

182 BROADWAY
COR OF JOHN ST.
NEW YORK

• CHICAGO • No 125 STATE STREET • 33 HOLBORN VIADUCT • LONDON •

S. J. COX SS. DEL. N. Y.

THE

NEW HAVEN CLOCK CO.

MANUFACTURERS,

IMPORTERS,

DEALERS.

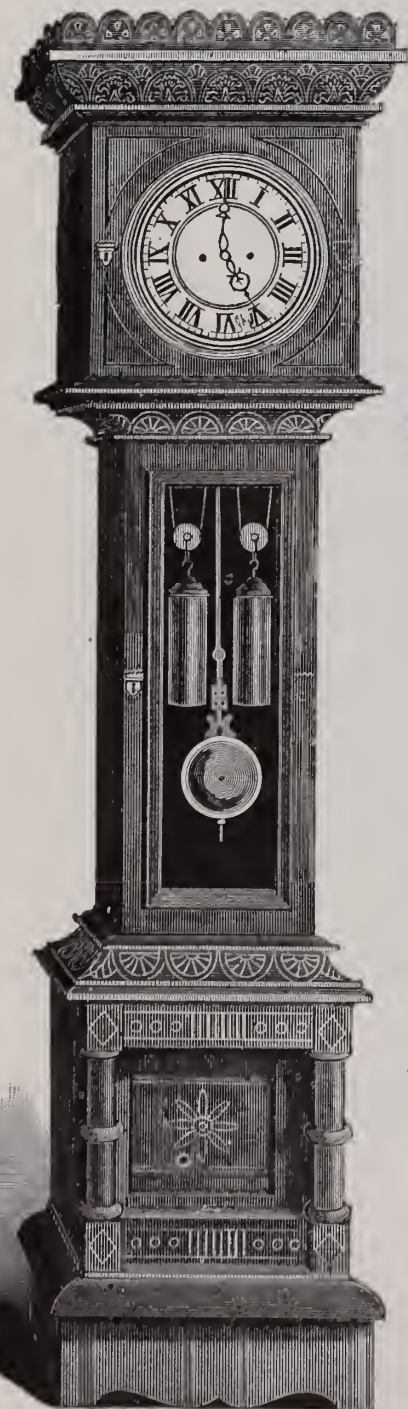

CARVED WOOD,
English Regulator.

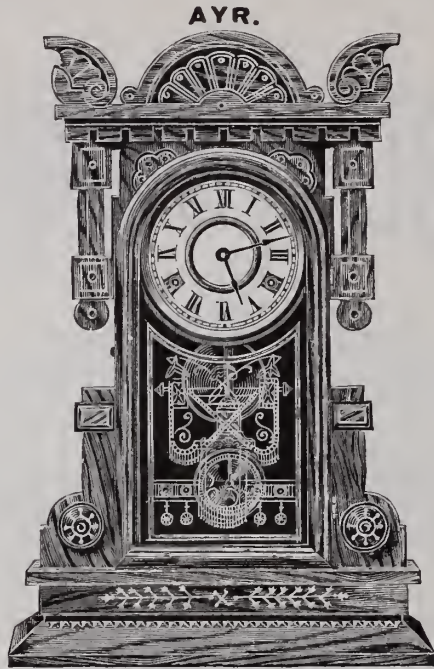

AYR.

FACTORIES.
NEW HAVEN, CONN.

GENERAL OFFICE AND SALESROOMS.
62 READE STREET,
New York.

WESTERN OFFICE AND SALESROOMS.
31 WASHINGTON ST.,
Chicago, Ill.

EUROPEAN OFFICE AND SALESROOMS.
16 PITT STREET,
Cleveland Sq., Liverpool,
England.

WE have again introduced many Popular Improvements as well as New Designs, combining the most desirable effects and thorough construction with moderate prices. Among these will be found our new 8-day Pendulum Movements, striking hours and half hours on Gong Bells with Cathedral tones. By this means we bring within the reach of all the best selling points of the most expensive imported clocks.

We also call attention to the fact that we sell these Cathedral Gongs either separately or fitted in any of our Visible Pendulum Clocks at a moderate extra charge.

We now have the greatest facilities for

IMPORTING

all kinds of

French Clocks

and

BRONZES,

and are pleased to ask our patrons to give this fact their careful attention and allow us, by a trial, to show them that we can offer a better and cheaper assortment than any other house.

Send for Complete Catalogue of All Styles.

No. 1035.



MARBLE,
Imported.

W. H. SHEAFER & CO.,
15 JOHN STREET,
—NEW YORK.—



Warranted.

SPECIAL NOTICE.

New York, January 31st, 1883.

To the Trade:

Hereafter all of our Goods will be stamped with our Trade Mark, as above,  and we guarantee the Gold to be strictly 14 Karats Fine (583/1000 assay). We this year add a full line of all Black Enamelled Bands, Plain Black Enamelled, Gold Figured, Plain Black with Settings for Diamonds "Kily of the Valley" in Pearls, and many other fancy patterns set with Pearls. These, with our Engraved, Engraved and Enamelled "Stiffened" Roman and Solid Roman Bracelets, we shall offer to the trade at as Close Prices as strictly 14 Karat Bracelets can be made. Price Lists sent to the Trade upon application. Goods sent on memorandum selection upon receipt of satisfactory references.

Truly Yours, etc.,

W. H. Sheaffer & Co

Factory: Philadelphia, Pa.



CARTER, SLOAN & CO.,
 MANUFACTURERS OF ALL KINDS OF
GOLD JEWELRY,
 BROADWAY AND FOURTH STREET,
 NEW YORK.
 C. E. HASTINGS,
 G. R. HOWE.
 A. CARTER, JR.
 A. K. SLOAN,

BALDWIN, SEXTON & PETERSON,
 IMPORTERS OF
DIAMONDS and all **PRECIOUS STONES,**
 MANUFACTURERS OF
 DIAMOND AND RICH JEWELRY.
 Cutters and Polishers of
DIAMONDS
 692 & 694 BROADWAY, NEW YORK.
 120 SUTTER ST., SAN FRANCISCO, CAL.

J. F. Chatellier,
 Manufacturing Jeweler,
 692 & 694 Broadway,
 New York.



TRADE MARK.
 STERLING.
Whiting Manufacturing Co.
 SILVERSMITHS,
 BROADWAY & FOURTH ST., N. Y.

ESTABLISHED 1837.
TAYLOR & BROTHER,
 Old House READ, TAYLOR & CO.,
Importers of Diamonds and Pearls,
 —)AND(—
 MANUFACTURERS OF DIAMOND JEWELRY,
 21 Holborn Viaduct, 676 Broadway,
 LONDON. NEW YORK.

ESTABLISHED 1813.
THOMAS G. BROWN & SONS,
 Newark, N. J., & 5 Bond Street, New York.
 MANUFACTURERS OF
ARTISTIC JEWELRY
 FOR PRESENTATION,
 Including Prizes for **ROWING, RIFLE SHOOTING, ARCHERY** and
 all **ATHLETIC SPORTS.**
 COLLEGE SOCIETY PINS AND CLASS RINGS, ALSO BADGES FOR MILITARY
 AND CIVIC BODIES IN ALL METALS.
 Employing able Designers, and having all work, both in Designing and Manu-
 facturing, done in our own factory, we can submit, for the inspection of those
 interested, entirely original designs, appropriate in style, and not to be seen else-
 where.
 Estimates and Designs will be sent to Reputable Dealers when desired.

ESTABLISHED 1834.

G. & S. OWEN & CO.,

—MAKERS OF—

FINE ROMAN JEWELRY, &c.

—&c. BOX and GLASS PINS,

—AND—

Black Onyx and Pearl Goods,

OF EVERY DESCRIPTION.

All Goods sold by us are exclusively of our own manufacture and are warranted 14 K. Fine, and stamped as such when possible.

No. 3 Maiden Lane, New York.

W. H. SHEAFER & CO.,



15 John St., New York.

FACTORY, PHILADELPHIA.

RIPLEY HOWLAND M'F'G CO.,

MAKERS OF

FINE JEWELRY,

SPECIALTIES:

DIAMOND MOUNTINGS, with Platinum Tips.
ENGRAVED RINGS, STONE RINGS,

OFFICE, 17 MAIDEN LANE,
NEW YORK.

FACTORY, 383 WASHINGTON ST.,
BOSTON, MASS.

SAXTON, SMITH & CO.,

Manufacturers of

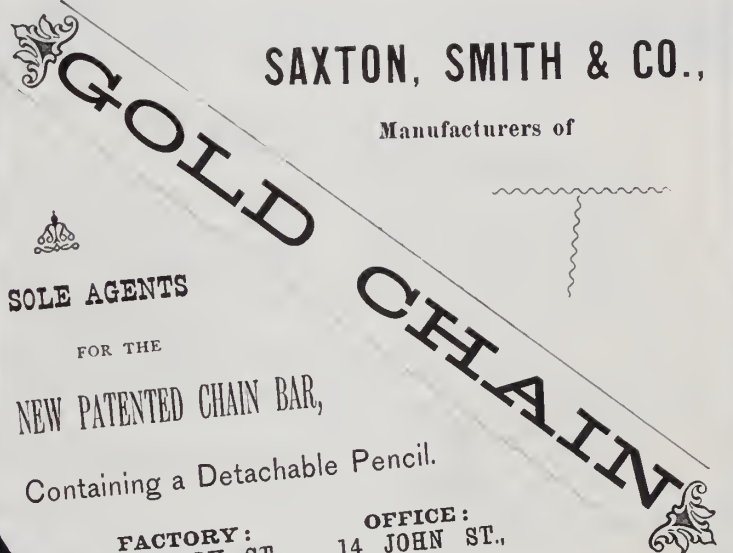

SOLE AGENTS

FOR THE

NEW PATENTED CHAIN BAR,

Containing a Detachable Pencil.

FACTORY:
183 EDDY ST.,
PROVIDENCE, R. I.

OFFICE:
14 JOHN ST.,
NEW YORK.

A. J. HEDGES & CO.,

MANUFACTURING

JEWELERS,

No. 6 MAIDEN LANE,

NEW YORK.

Factory, No. 90 MECHANIC ST.,
NEWARK, N. J.

A. W. FABER'S

CELEBRATED

Gold Pens & Pencil Cases.
TOOTH PICKS AND NOVELTIES.

Manufactured by

EBERHARD FABER,

Nos. 718 and 720 Broadway,
NEW YORK.

J. B. BOWDEN & CO.,

MANUFACTURERS OF

SOLID RINGS

Of Every Description.

No. 1 MAIDEN LANE,

Cor. Broadway,

NEW YORK.

MOORE & HORTON,

No. 11 Maiden Lane,

NEW YORK.

JEWELERS

SPECIALTIES:

Stone Cameo, Onyx, Amethyst, Topaz
and Pearl Rings.

Studs, Collar and Sleeve Buttons.

Also our fac-simile of Fine African Diamonds,
with Foile Back, Mounted in Rings, Studs,
Pins, Ear Rings, Scarf Pins, Lace Pins, &c.

JOHN F. SAUNDERS,
Of the late firm of Buckenham, Cole & Saunders.

CHAUNCEY IVES.

SAUNDERS & IVES,
IMPORTERS OF

DIAMONDS, PEARLS,
And Other Precious Stones.

Manufacturers of Diamond Mountings.

No. 26 MAIDEN LANE, NEW YORK.

A Large Stock of FINE DIAMONDS, Mounted and
Unmounted, kept constantly on hand.

Goods sent on approval to any part of the country on receipt of
satisfactory reference. All our goods ARE IN-
SURED by us while in transit.

CHAMPENOIS & CO,
NO. 5 MAIDEN LANE, NEW YORK.

Manufacturers of Solid Gold Jewelry,
AND THE

"BEST  LEVER"

SLEEVE AND COLLAR BUTTON.

Also Sets, Ear Knobs, Bracelets, Studs, Lace and Cuff
Pins, Onyx and Jet Cluster Goods.

Specialty:—Engraved and Enameled Goods.

G. W. PRATT & Co.,

Manufacturers and Dealers in

Watches and Jewelry

OF EVERY DESCRIPTION.

ELGIN AND ILLINOIS MOVEMENTS
IN ALL GRADES.

Gold, Silver and Ladd Patent Cases.

No. 14 JOHN STREET, NEW YORK.

C. ROSSWOG & SON,

MANUFACTURERS OF

Rich Jewelry and Diamond Goods,

NOS. 5 & 7 MAIDEN LANE,

—NEW YORK.—

ESTABLISHED 1850.

JOHN T. MAURAN,

MANUFACTURER OF

→ **FINE ROLLED PLATE GOODS,** ←

15 MAIDEN LANE, NEW YORK.

SPECIALTIES FOR THE SPRING.

FULL LINE OF

STONE LACE PINS IN RUBY AND SAPPHIRE DOUBLETS,
GARNETS, AND FOILED WHITE STONES,

Jet Lace Pins, Sets and Ear Knobs, Solid Gold White Stone Knobs,

ALSO

Full Line of Coral and Wire Sets, Lace Pins, Knobs, &c.

These Goods which are so well and favorably known to the Trade, bear this

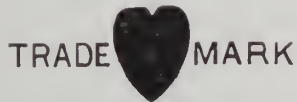

as well as the same being stamped on the cards.

JULIEN GALLET & CO.
IMPORTERS OF

WATCHES

OF EVERY GRADE.

No. 1 MAIDEN LANE,

NEW YORK.

Webster's Silver Solution,

PREPARED BY

E. G. WEBSTER & BROTHER,

(Established 1859.)

Manufacturers of Quadruple
Electro Silver Plated Ware

14 MAIDEN LANE, N. Y.,

Expressly for Cleaning Silver and Silver
Plated Ware.

Jewelers will find this a valuable adjunct for
cleaning their stock, and a reliable article to
recommend to their customers.

Guaranteed entirely free from Cyanide, Acid,
Grit, or anything detrimental to the Finest
Wares.

Packed in Boxes containing 2 Doz. Bottles.

Price, \$1.25 per Doz., NET.



S. W. HALE & CO.,

SUCCESSORS TO HALE & MULFORD,

MANUFACTURERS OF

FINE JEWELRY,

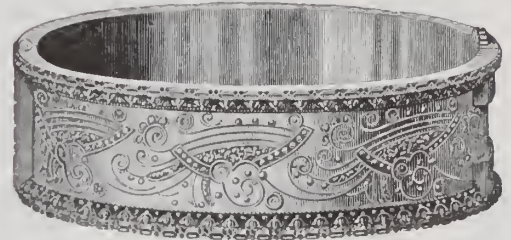

692 Broadway, New York.

SETH W. HALE.

WILLIAM A. LEE.

WILLIS H. HOWES.

USE GOLD STOCK PLATED CHAINS

With Swivels Stamped

"R. F. S. & CO."

Every Chain Guaranteed by the Makers.

R. F. SIMMONS & CO.

ATTLEBORO FALLS, MASS.

Sold ONLY through Wholesale Houses.

ESTABLISHED 1855.

WELCH & MILLER,

JEWELRY
CASE MANUFACTURERS,

OF MOROCCO, VELVET, RUSSIA, BROCADE AND PLUSH.

TRAYS OF ALL DESCRIPTIONS.

Telescope Sample Cases with Flexible Trays.

Agents for Jewelers' Cotton and Twine.

A Large Stock Always on Hand.

169 BROADWAY,

NEW YORK.

CHAS. F. TERHUNE & CO.,

ROLLED PLATE CHAINS, and
GOLD and PLATED JEWELRY.

MANUFACTURING JEWELERS,

Terhune's Patent Slide Buttons.



194 BROADWAY,



NEW YORK.

ESTABLISHED 1867.

F. JEANDHEUR, Jr.,

125 FULTON STREET, N. Y.

Gold and Silver Electro-Plating.

Mr. Jeandheur begs to notify the Trade that he has made more improvements with his new process of Electro-Plating Watches, Jewelry, Etc. By having introduced an Electro-Plating Machine instead of using the old method of plating with Chemical Battery, he is able to plate with a far greater depth of gold than before, and for wear it is equal to rolled plate. The Trade can rely on this statement, as a trial will abundantly prove, and his well-earned reputation amongst the leading houses in the Trade will be sustained.

P. S.—He also begs to notify the Trade that he has no connection with any other house or person using his name, for the purpose of soliciting work.

PRICE LISTS SENT UPON APPLICATION.

Patented November 18, 1873.

**MORRISON'S
Gold & Silver Solutions**

For Electro-Plating Without a Battery.

Invaluable for Watchmakers and Jewelers. So simple that any one can use them.

Price, Gold Solution, - - \$3.00 Silver Solution, - - \$1.50

MANUFACTURED BY

ARTHUR B. MORRISON, Portland, Maine.

FOR SALE BY

Sussfeld, Lorsch & Co., New York; Henry Ginnel, New York; Cross & Beguelin, New York; Kearney & Swartchild, Chicago, Ill.; Louis A. Scherr & Co., Philadelphia, Pa.; Duhme & Co., Cincinnati, O.; Harwood Bros., A. Paul & Co., Palmer, Bachelder & Co. Boston, Mass., and material dealers generally.

BEWARE OF BASE IMITATIONS put up by unprincipled persons. None are genuine without the Trade Mark which consists of the letters A. B. M. in monogram and fac simile of Medal awarded by U. S. Centennial Commission.

PEARCE & HOAGLAND,

MANUFACTURERS OF

Gold Pens, Pencils, Pen Holders, Tooth Picks,
OF EVERY DESCRIPTION.



CLOSED

SOLE MANUFACTURERS OF THE

QUILL RESERVE TOOTH PICK,



OPEN



CLOSED

The Only Pick that will not Injure the Teeth.

FOR SALE BY ALL JOBBERS.

Office and Factory, 29 Point Street, Providence, R. I.

JAMES W. TODD,

SUCCESSOR TO GEO. W. PLATT,

Wholesale Dealer in

WATCHES & JEWELRY,

GOLD AND SILVER SPECTACLES

And Eye-Glasses,

No. 6 LIBERTY PLACE,

NEW YORK.

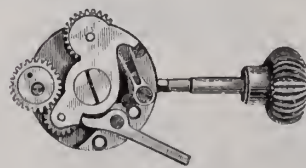

For AMERICAN
18 Size Watches.

ABBOTT'S
PATENTS.

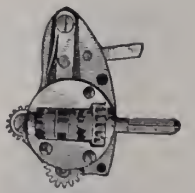

For HOWARD
16 & 18 Size Watches.

HENRY ABBOTT,

7 MAIDEN LANE,

NEW YORK.

MANUFACTURER

FOR SALE BY JOBBERS.

MANUFACTURERS
OF
Everything in
BLACK ONYX JEWELRY
PLAIN, and {Ornamented with
 { Pearls and
 { Diamonds.

Our manufacturing facilities have been for the past ten years devoted exclusively to the production of fine Black Onyx Jewelry. We carry in stock the largest variety of articles made in our specialty, well made, finely finished, uniformly 14 karats, at medium and low prices.

WOGLOM & MILLER,
Office & Factory, 32 & 34 JOHN STREET,
NEW YORK.

W. C. GREENE & CO.
GOLDSMITHS.
MANUFACTURERS of

RICH SETS IN TAPER WIRE CORAL

Factory 95 PINE ST. Providence, R. I.
Stone Cameo
Amethyst
Coral Cameo
Engraved
Enamel Sets
Brooches
Sleeve Buttons
Stud Buttons
Ear Drops
&c. New York Office 192 BROADWAY.

WM. C. GREENE. B. W. GREENE. GEO. D. BRIGGS

TO LET.

Floors 45x90 with Power, in New Building, cor. of York and Washington Streets, Brooklyn. Suitable for Jewelers and Silversmiths. Light on all sides. Conveniences for Burning and Grinding Sweeps. A night watchman in building. Location near terminus of bridge.

KETCHAM & McDOUGALL,

4 LIBERTY PLACE, N. Y.

MANUFACTURERS OF

GOLD AND SILVER THIMBLES,

And the Automatic Eye-Glass Holder.

ESTABLISHED 1859.

STURDY BROS. & CO.
MANUFACTURERS OF

Fine Rolled Plate Jewelry,
GRADUATED WIRE CORAL GOODS,
STERLING SILVER JEWELRY.

Bangles, Sleeve Buttons, Cuff Buttons, Baby Pins, Sets in Stone, Cameo, Enamel, Chased, and Polished, Drops and Knobs, Bar Pins, Children's Sets, Lockets, Studs, Charms, Etc.

Only Wholesale Dealers' Trade Solicited. ATTLEBORO, MASS.

Flexible Bracelets,
Diamond Mountings,
Strung Pearl Work,
Repairing,

Flexible Braided
Bracelets,
White Stone Goods,
Strung Pearl Repa'ng

Thos. W. Guilbert & Co.,

SUCCESSORS TO CARROW, DUBOSQ & Co.

908 Chestnut Street, Philadelphia, Pa.

B. A. BALLOU & CO.,

61 Peck St., Providence, R. I.

MANUFACTURERS OF

GOLD JEWELRY.

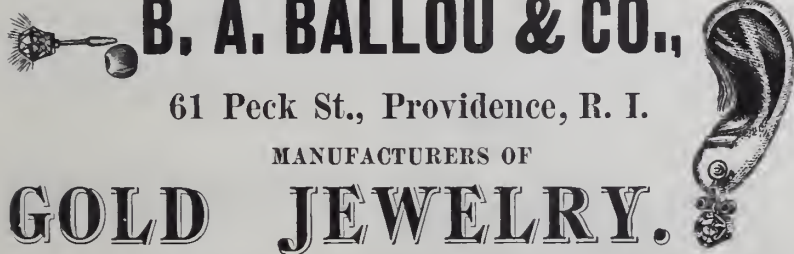

We call special attention to our PATENT FASTENING FOR EAR RINGS, which is free from the objections raised to ordinary ear wire or screw fastenings. They present a very neat and attractive appearance, are perfectly secure, and much more convenient than ordinary ear wires which always annoy the wearer by catching the hair, veil, or lace about the neck. These Goods are for Sale by all Wholesale Dealers.

Gold Studs, Small Chains for Eye-Glasses, Bracelets, Etc. a Specialty.

JAMES J. FISHER,
DEALER IN
WATCHMAKERS' and JEWELERS' MATERIALS,

Files, Tools, Silk Guards, Watch Glasses, Spectacles, Rolled Plate, Fire Gilt, Nickel and Silver Chain, Charms, &c.

No. 697 BROADWAY,
Corner Fourth Street, NEW YORK.
All kinds of Job Work for the Trade Promptly attended to.

The "Acme" French Clock Movement Support.
(Pat. Nov. 1st, 1881.)

This Support is adapted to the holding in position of any French Clock Movement while regulating or adjusting, and will be found very desirable on account of its simplicity of action and the small space it occupies. To be had of any respectable jobbing house, or sent, post paid, to any address, on receipt of 60 cents.



McCarty & Hurlburt,
WHOLESALE DEALERS IN
WALTHAM, ELGIN & ILLINOIS
WATCHES.
MANUFACTURERS OF
Jewelry, Gold Spectacles, Silver Thimbles, &c
131 North Second St.,
PHILADELPHIA, Pa.

C
L
O
C
K
S

ESTABLISHED 1853.



AMERICAN

AND

FRENCH CLOCKS

AND

BRONZES.

B. J. COOKE'S SONS,137 N. 3d Street, PHILADELPHIA.
Catalogues and Price Lists furnished to the Trade only, on application.**BOOZ & CO.,**

MANUFACTURERS OF

FINE GOLD

Watch Cases



AND

PLAIN GOLD

RINGS.

Jobbers in American Movements.

DIAMONDS.

108 South Eighth St., (2d Story) Philadelphia.

Samples of our goods sent on approval when satisfactory reference is furnished.
Old Gold and Silver Bought or Exchanged.

PARTICULAR ATTENTION PAID TO REPAIRING.

The ORIGINAL GOLD CROWN
FILLED RINGS.

For the past thirteen years we have manufactured as a specialty, the well known "CROWN GOLD FILLED RING," with the high standing of which the trade is already perfectly familiar. In consequence of the above fact, and in justice to ourselves, we feel it a duty to make the announcement to the trade that there are now being offered in the market several other makes of filled rings, each of which has a CROWN in some way connected with its STAMP.

We Manufacture for the Jobbing Trade Only.

McCALL & NEWMAN,

625 Arch Street, Philadelphia

O. W. BULLOCK,

SPRINGFIELD, MASS.,

MANUFACTURER OF

FINE NICKEL PLATED WATCH & JEWELING TOOLS,

Watch Keys and Light Metallic Goods.



SEND FOR NEW ILLUSTRATED CATALOGUE AND PRICE LIST.

HERPERS BROS.,

MANUFACTURERS OF

SETTINGS, &c.

18 CRAWFORD STREET, NEWARK, N. J.

Send for PATTERNS and PRICES.

Established 1848.

HENRY HARRISON,

66 NASSAU ST., NEW YORK,

MANUFACTURER OF

Gold Bangles,**Bangle Rings,**

AND

Gold Flat Band and Buckle**BRACELETS,**

Both Engraved and Enameled.

ALSO DEALER IN WATCHES AND JEWELRY.

IMPORTER OF THE BEST G. S. CHAIN.

B. W. KOOPMAN,

MANUFACTURER AND PATENTEE OF THE CELEBRATED

AUTOMATIC FIRE LIGHTING CLOCK.

The Ninth Wonder of the World.

Already Introduced on both sides of the OCEAN.

*Sample of our New Style of Clock
sent to Jewelers at a Reduced Price.*For Circular, containing full particulars,
with Terms to Dealers, Address**KOOPMAN'S PATENT CLOCK WORKS,** Terre Haute, Ind.

Refer to any Commercial Agency in U. S.

William T. Smith,
ASSAYER, REFINER AND SWEEP SMELTER.

ESTABLISHED IN 1855.

Cor. Blackstone & Hawkins Sts

PROVIDENCE, R. I.

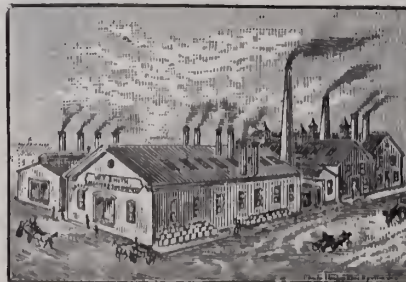

PROVIDENCE, R. I., Feb. 1st, 1881.

To whom it may Concern:

We take pleasure in recommending Mr. WM. T. SMITH. He has done the whole of our Refining ever since he has been in business, and we have ever found him prompt in making returns, and always to our satisfaction.

D. WILCOX & CO.

ROGERS' SILVERWARE.

MATERIALS AND TOOLS.

JEWELRY AND WATCHES.

S. F. MYERS & CO.,
Manufacturers and Jobbers,
 179 BROADWAY, NEW YORK.

ILLUSTRATED CATALOGUE FOR THE TRADE.

W. E. WHITE & CO.,
 Manufacturing Jewelers.

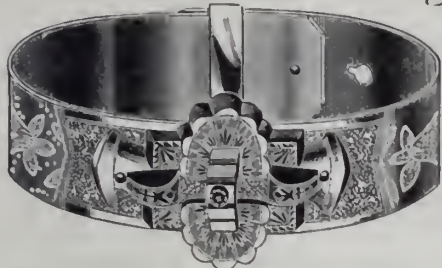

**FINE
 ROLLED PLATE
 GOODS.**

Bracelets---Engraved, Enamelled, Flat Band and Buckle.

Ladies' Goods—Lace Pins, Drops, Crosses, Sets, Collar Buttons, &c.

FOR SALE BY JOBBERS ONLY.

New York Office, 26 MAIDEN LANE, Corner Nassau Street.

Factory 54 Page St., Providence, R. I.

Represented by S. A. BALDWIN.

ALEX. MILNE,
 Manufacturer of Stem-Winding Watch Crowns



ALSO GOLD AND SILVER THIMBLES.



19 Ward Street, NEWARK, N. J.

PFORZHEIMER, KELLER & CO.

MANUFACTURERS OF

FINE JEWELRY,

AND DEALERS IN

American and Swiss Watches,

No. 24 JOHN STREET,

I. PFORZHEIMER,
 D. KELLER.

NEW YORK.

{I. B. ETTINGER,
 {H. J. FINK.

Henry Ford,

Importer of Rough & Polished Diamonds,

DIAMOND CUTTING AND POLISHING WORKS:

21, 23, 25 Looijersgracht,  4 & 6 JOHN ST.,
 Amsterdam, Holland. New York.

Diamonds repaired and matched by some of the finest workmen in the world.

Diamond Bort and Powder always on hand.

ESTABLISHED 1850.



TRADE MARK

PETER L. KRIDER,
 MANUFACTURER OF
STERLING SILVERWARE

Medal and Diploma Awarded. &c. Striking Society
 Medals in Gold, Silver or Bronze a Specialty.

Artisan Hall, 618 Chestnut St., Philadelphia.

BARNET BROS. & POWELL

Newark, N. J.,

— AND —

15 JOHN ST., NEW YORK.

R. & K.'S PATENT GAS FURNACES FOR MELTING, PLATING,
 ENAMELING, ANNEALING, &c., &c.

Reichhelm & Koester,

Importers and Manufacturers of

Jewelers' Tools, Files, Materials, &c.,

Manufacturers of
 Bristle Brushes of all kinds,
 Cotton and Wool Buffs,
 Felt Polishing Wheels,
 Walrus Leather Polishing
 Wheels,
 Jewelers' Satin Finish and
 Scratch Brushes,
 Brass & Steel Wire Brushes
 Jewelers' Standard Saw
 Frames,
 Plain & Fancy Draw Plates,
 Improved Jewelers' Ingots,
 R. & K.'s Jewelers' Combi-
 nation Gas Burners.

80 Nassau St.

NEW YORK.

Importers of
 French, English & German
 Tools and Files,
 Piercing Saws,
 Renard & Vautier Gravers,
 Steel and Brass Wires,
 Vienna and Ruby Draw
 Plates,
 Alloying Copper Wire,
 Felt, Walrus Leather,
 Vienna Lime, Tripoli,
 &c., &c., &c.

Send for Illustrated Catalogue.

SOMETHING NEW!!



Extra Fine Screwdriver, 35 cents Each.
Set of Five, \$1.50.

Send for 36 Page Catalogue of Fine Watch-makers' Tools, manufactured by

J. G. HALL MFG. CO.,
ROXBURY, VERMONT.

GEO. W. DUBOIS. F. N. NAUMAN.

GEO. W. DUBOIS & CO.,
IMPORTERS OF

Watches & Optical Goods.

ALL STYLES AND QUALITIES OF
SPECTACLES AND EYE-GLASSES.

LONGINES' WATCHES AND MOVEMENTS.

The Watches in Gold, Silver and Nickel Cases of New and Handsome Patterns. The Movements fit 18 size Waltham Stem Winding Hunting Cases.

36 MAIDEN LANE, NEW YORK.

Orders by Mail Receive Prompt Attention.

THE
Jewelers' Circular & Horological Review.

THE RECOGNIZED ORGAN OF THE TRADE.

Published Monthly, at - - \$2.00 per Annum.

D. H. HOPKINSON,
Editor and Proprietor.
42 NASSAU STREET, N. Y.

Volume XIV commenced with the February Issue.

JOSEPH STERN. JACOB STERN. SIMON STERN.

STERN & STERN,
Wholesale Dealers in
WATCHES & DIAMONDS
And Manufacturers of
GOLD JEWELRY,
6 MAIDEN LANE, NEW YORK.

AGENTS FOR THE CELEBRATED
MELVILLE & NEW BRIGHTON WATCHES.

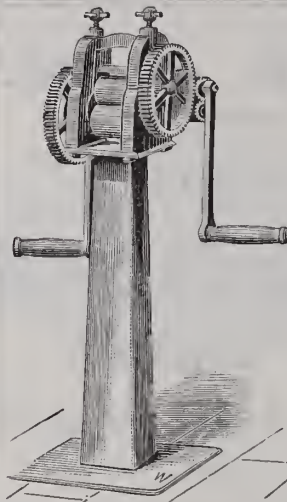

W. W. OLIVER,

MANUFACTURER OF

Hand and Power
Rolling Mills,

For Jewelers and Silversmiths.

The "Little Giant" Ring Bender

Hollow Spindle Lathes, Punching and Dro Presses, Polishing Heads, Dies, Metal Laps, Etc.

39 CLINTON STREET,
BUFFALO, NEW YORK.

Illustrated Price List mailed free upon application.

EXCELSIOR'S
PRACTICAL TREATISE ON THE
Balance Spring,

INCLUDING MAKING AND FITTING HAIR SPRINGS,
REGULATING, ETC.

Also containing the Adjustment of Watches and Chronometers for Isochronism, Positions, Heat and Cold and Rate.

Price, \$3.50.

D. H. HOPKINSON,
42 Nassau St., New York.

L. W. LEVY. ED. DREYFUS. PHILIP HECHT.

LEVY, DREYFUS & CO.,
No. 11 MAIDEN LANE,

P. O. Box 3567, NEW YORK.
MONOGRAM ALBUMS, \$5 & \$10 EACH.

SOLE AGENTS FOR THE MOST COMPLETE BOOK OF

COMBINATION MONOGRAMS
OF 3 and 4 LETTERS,

OF THE LATEST DESIGNS,

PRICE, - - - \$10.

One of 2 Letters and 35 Series of Alphabets, \$5.



WHEELER, PARSONS & HAYES,
 MANUFACTURERS OF
WATCH CASES, GOLD CHAINS & FINE JEWELRY

Importers of Diamonds and Manufacturers of Diamond Jewelry,
And Dealers in American and Swiss Watches,
No. 2 MAIDEN LANE, NEW YORK.

Established 1841.

Enos Richardson & Co.,
 Manufacturers of Gold Jewelry and Chains,
 23 Maiden Lane, New York.

Goods sent on approval to Dealers in any part of the U. S. upon receipt of order with satisfactory references.

San Francisco Office, 206 Kearny St., Haskell & Muegge, Agents,
 Where a full line of our goods can always be found at Eastern Prices.

THE
 "POTTER WATCH."

ALBERT H. POTTER & CO.,
 7 RUE DU MONT BLANC,
 GENEVA.

BURGER & CO.,
 12 JOHN STREET,
 NEW YORK.

Established 1828.

JACOB BENNETT & SON,
 Diamond Setters and Manufacturing Jewelers,
 No. 923 CHESTNUT STREET, PHILADELPHIA.

WE MANUFACTURE AND MAKE A SPECIALTY OF
 EVERY DESCRIPTION OF

DIAMOND MOUNTINGS,

SUPERIOR IN DESIGN AND WORKMANSHIP.



Dealers in

DIAMONDS

And all kinds of Precious Stones.

Of which we keep a Large Assortment Constantly on Hand.

Masonic Marks, Society and School Badges, Made to Order Only. Designs and Estimates Furnished.

PARTICULAR ATTENTION GIVEN TO ALL KINDS OF JOBBING.

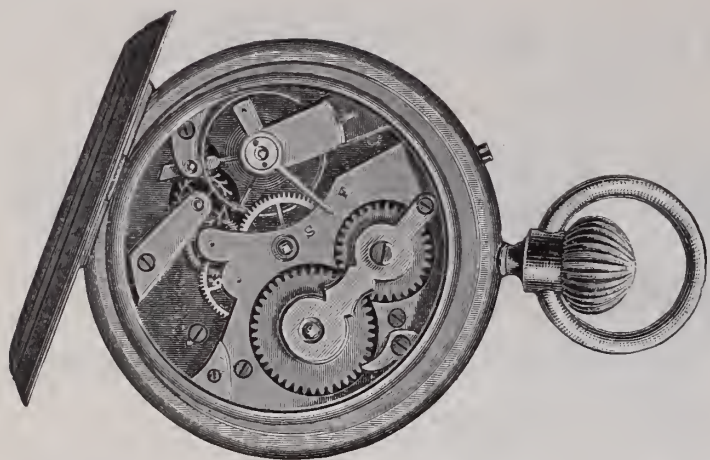

ESTABLISHED 1839.

HENRY GINNEL,
31 Maiden Lane, N.Y.

SOLE IMPORTER OF THE

PIONEER WATCH

Acknowledged by the Trade to be the best Watch for the money in the world.

They are for Sale by all the leading Houses throughout the land.

A. J. WARNER & CO.,
WHOLESALE JEWELERS,

309 Nicollet Avenue, Minneapolis, Minn.

We carry a Large and Elegant Stock of Jewelry, Watches, Cases, Etc., Etc.

North-western Agents of the WATERBURY CLOCK CO., and carry a Complete Line of their Goods.

OUR TRADE IS EXCLUSIVELY WITH THE JEWELERS.

WASHBURN'S PATENTS

SHUT OPEN
SAFETY CATCH, Pat. Sept. 20, '81, Jan. 10, '82.

Safety Ear Fastening No. 1. Patented May 10, 1881.

Jointed Ear Wire and Bar between Cramp of Setting. Patented March 10, 1881.

Safety Ear Fastening No. 2. Patented October 11, 1881.

ADOPTED AND IN USE BY
RANDEL, BAREMORE & BILLINGS,
DIAMONDS,
58 NASSAU STREET,
NEW YORK.

Address or Apply to
GEO. W. WASHBURN
58 NASSAU ST.,
NEW YORK.

Descriptive Circulars FURNISHED ON APPLICATION.

N. H. WHITE,

JOBBER IN

American-Waltham Watches,
EXCLUSIVELY.

Waltham make of gold and silver cases a Specialty. Ladd, Boss, and the Patent Screw Bezel Filled Cases to fit Waltham movements only

No. 11 MAIDEN LANE, NEW YORK.

I not only advertise that I have the Waltham Goods, but **have constantly on hand** the Largest Stock carried by any jobber in the trade. Gold Cases of all Weights and Styles. Memorandum Packages with pleasure.

COMPLETE PRICE LIST FURNISHED TO THE TRADE.

W. M. S. HEDGES & CO.,

IMPORTERS OF

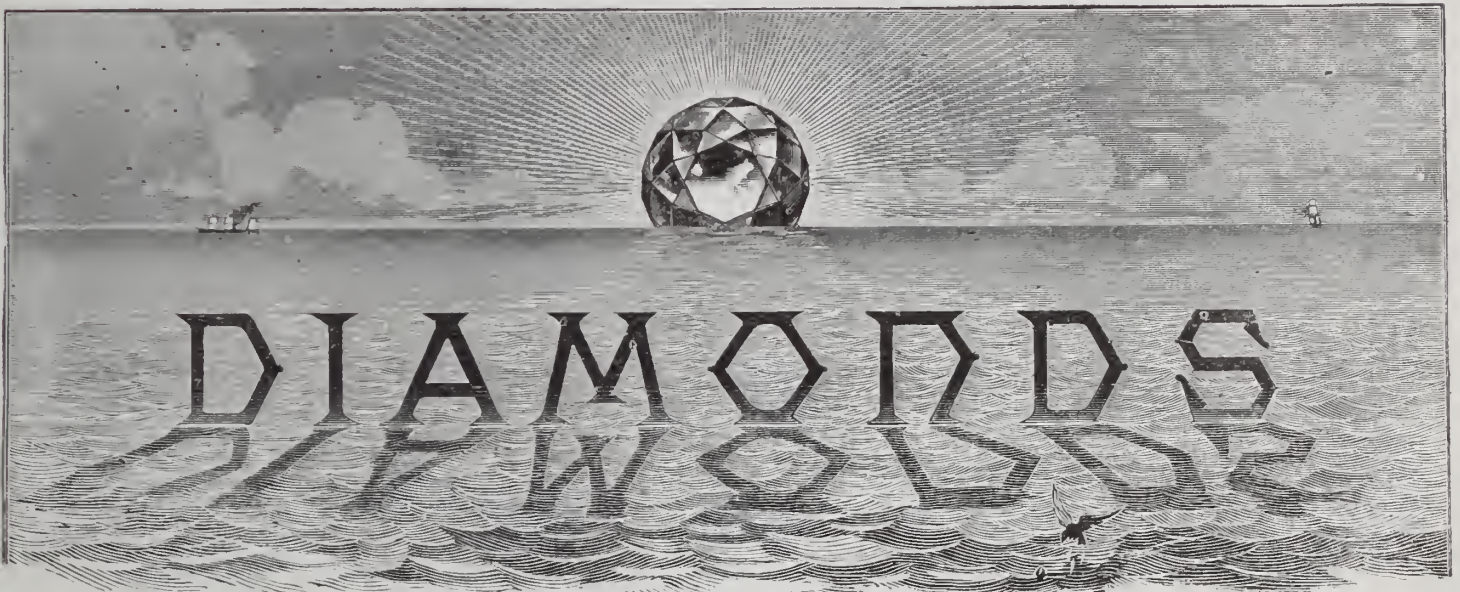

COPYRIGHT SECURED.

Entered According to Act of Congress in the year 1880, by W. M. S. HEDGES & CO., in the Office of the Librarian of Congress, at Washington.

No. 170 BROADWAY,

Corner Maiden Lane, New York.

Choice Brilliants in Single Stones and Matched Pairs a Specialty.

Fresh invoices of Goods in all Grades constantly arriving. Also choice parcels of exceptionally Fine Gems Especially selected for critical purchasers. A full line of Mounted Goods Artistically Designed.

GOODS SENT ON APPROVAL.

More Valuable Information for

The U. S. Mint Assay shows that Gold Case No. 8576, bought in Philadelphia for 18 karat, was below the quality stamped and paid for.

Stamped 18 Karat, Invoiced $53\frac{1}{2}$ dwts.

The buyer of this Case supposed that he was getting $53\frac{1}{2}$ dwts. of 18 karat gold, for which he paid \$42.80, instead of which he got $43\frac{1}{2}$ dwts. of $16\frac{1}{2}$ karat gold, worth \$32.19, and $8\frac{1}{4}$ dwts. of steel in Springs and Key Pipe, and $1\frac{3}{4}$ dwts. of brass in Crown, to which must be added the price paid for making.

The U. S. Mint Assay shows that Gold Case No. 6234, bought in New York for 14 karat gold, was below the quality stamped and paid for.

Stamped 14 Karat, Invoiced $40\frac{1}{2}$ dwts.

The buyer of this Case supposed that he was getting $40\frac{1}{2}$ dwts. of 14 karat gold, for which he paid \$25.92, instead of which he got 31 dwts. of $13\frac{1}{4}$ karat gold, worth \$18.91, and 8 dwts. of steel in Springs and Key Pipe, and 2 dwts. of brass in Crown, to which must be added the price paid for making.

The U. S. Mint Assay shows that Gold Case No. A7700, bought in New York for 14 karat, was below the quality stamped and paid for.

Stamped 14 Karat, Invoiced $42\frac{1}{4}$ dwts.

The buyer of this Case supposed that he was getting $42\frac{1}{4}$ dwts. of 14 karat gold, for which he paid \$27.04, instead of which he got 36 dwts. of $13\frac{1}{2}$ karat gold, worth \$22.32, and $5\frac{1}{4}$ dwts. of steel in Springs and Key Pipe, and 1 dwt. of steel in Crown, to which must be added the price paid for making.

Plump 14 Karat Gold is $583\frac{33}{100}$ Fine.

" 18 " " 750 "

By referring to the figures in opposite table and comparing them with the standards as shown above, the Buyer will see the difference between the quality as proven by assay and the actual value of the Gold furnished.

The above Assays were made at the U. S. Assay Office purpose, and it is proper to allow one-half of a karat for

Buyers of Gold Watch Cases.

The U. S. Mint Assay shows that Gold Case No. 15282, bought in San Francisco for 18 karat, was below the quality stamped and paid for.

The buyer of this Case supposed that he was getting 60½ dwts. of 18 karat gold, for which he paid \$48.40, instead of which he got 49³ dwts. of 15 karat gold, worth \$33.83, and 9 dwts. of steel in Springs and Key Pipe, and 1¼ dwts. of brass in Crown, to which must be added the price for making.

The U. S. Mint Assay shows that Gold Case No. 191233, bought in New York for 14 karat gold, was below the quality stamped and paid for.

The buyer of this Case supposed that he was getting 48½ dwts. of 14 karat gold, for which he paid \$31.04, instead of which he got 40¼ dwts. of 13 karat gold, worth \$24.15, and 7 dwts. of steel in Springs and Key Pipe, and 1¼ dwts. of brass in Crown, to which must be added the price paid for making.

Gold deposited at the U. S. Assay Office at New York.

DESCRIPTION.	GROSS WEIGHT.		FINENESS.	
	OUNCES.	DEC.	GOLD.	SILVER.
8576	690½
6234	554
15282	622½
191233	539
A7700	561½

Signed, J. F. WILDER, for Assayer.

in New York City. The entire Case was melted for the Solder, Joint Pins, etc.



Randel, Baremore & Billings,

Importers of

Diamonds

and Manufacturers of

Diamond Jewelry.

*58 Nassau Street,
8 29 Maiden Lane,
New York.*

*1 St. Andrews Street,
Holborn Circus,
London, E. C.*



HENRY C. HASKELL,

MAKER OF FINE GOLD JEWELRY.

No. 12 John St., New York.

Goods sent on approval to any part of the country, upon receipt of satisfactory references.

→* FOR * SPRING * TRADE * ←

INTAGLIOS IN NEW DESIGNS AT REDUCED PRICES.

NOVELTIES IN SCARF PINS,

SEALS, LOCKETS, &C., &C.

Illustrated Plates of Designs for Portfolio sent only to Dealers upon request.

House Established 1837,

Successor to J. A. ABRY.

CHARLES LEO ABRY,

Importer and Manufacturer of all Grades of

SWISS WATCHES,

And dealer in Elgin, Springfield, Ill., and Lancaster Movements.

Specialties in Gilt, Nicked and Nickel Stem-Winding Movements, Ladies' Sizes, to Fit Elgin Cases.

IMPORTER OF THE FOLLOWING WELL-KNOWN SWISS WATCHES:

Geo. Mayor, A. Ames Droz, Chas. Estine, F. Richard, Huguenin Nardin and Ernest Duval, as well as all kinds of Watches for the Jobbing Trade, including Nicked, Open-Face and Hunting Stem-Winders, Anchors and Cylinders, 16, 18 and 19 lines. Silver Key and Stem-Winders, Hunting and Open Face, all sizes and qualities, from low to highest grades. Silver and Nickel 13 and 14 line Watches for Chatelaines, Gold, Silver, Nickel & Rolled Plate Chatelaines of good styles & designs always in stock.



COMET.

SOLE IMPORTER.

Fits 8 Size Elgin Cases.

P. O. Box 611.

63 NASSAU STREET, NEW YORK.

Factory, Neuchatel, Switzerland.

→* M. FOX & CO., *←

Practical Lapidaries and Importers of

D I A M O N D S .

Rubies, Sapphires and Fancy Gems.

→* PEARLS, * * TURQUOISE, * * INTAGLIOS, * * ONYX, * * AMETHYST, * * ETC. *←

No. 1 MAIDEN LANE, NEW YORK.

LEON JEANNE.

PAUL JEANNE

JEANNE BROTHERS

MANUFACTURERS OF

DIAMOND MOUNTINGS,

AND RICH JEWELRY.

No. 1 MAIDEN LANE, NEW YORK

Designs Furnished and Estimates Given.

JEANNE BROS PAT. DIAMOND SETTINGS.

A PLATINUM SETTING WITH A GOLD SURFACE OUTSIDE

IN THIS WAY THE REFLECTION OF GOLD THROUGH THE DIAMOND IS ENTIRELY AVOIDED.

PAT. AUG. 15TH 1882

ESTABLISHED 1859.

RINGS A SPECIALTY.

BRYANT & BENTLEY,

12 MAIDEN LANE, Up-Stairs, NEW YORK.

AMONG OUR LATEST PATTERNS OF FINE SOLID RINGS ARE



587



591



584



504



589



490

No. 587—Made in Topaz and Amethyst. No. 591—Cluster of Garnets, Doublets or Turquoise, with Pearls and Diamonds. No. 584—Cameo or Garnet with Pearls and Diamonds. No. 504—Misses' Turquoise Rings. Nos. 490 and 589—Represent two patterns only of our Engraved Band Rings.

We also continue to make a full line of our well known 16 K. HARD SOLDER RINGS.

Goods sent on approval to responsible parties.

HENRY ZIMMERN,

IMPORTER OF

Watch Materials,

TOOLS,

AND OPTICAL GOODS,

No. 8 Maiden Lane, New York.

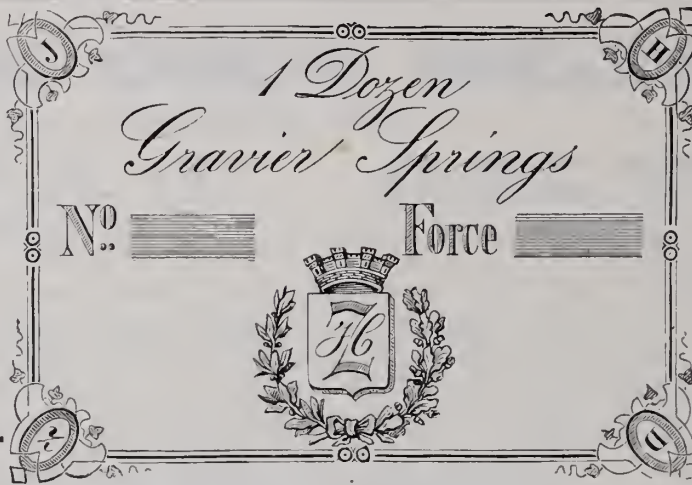

WHITE METAL CHAINS A SPECIALTY.

SOLE AGENT FOR THE CELEBRATED GRAVIER MAINSPRINGS.

The cut is a fac simile of trade mark with my monogram on wrapper, adopted by me to prevent the trade from being imposed upon with imitation springs. A brass tag attached to each spring indicates the number and strength according to Dennison's United States Standard Gauge. These Springs are to be obtained at all leading Jobbing Houses.

THEUERNER & CHURCH, MANUFACTURERS OF FINE RINGS,

No. 9 MAIDEN LANE,

NEW YORK.

FACTORY, COR. MULBERRY & DURAND STS., NEWARK, N. J.

A. BERNHARDT & CO.
MANUFACTURERS OF
DIAMOND & FINE JEWELRY
ORNAMENTAL HAIRWORK

OFFICE & FACTORIES
3, 4 & 5 FLOOR,
P.O. BOX 111.

2
MAIDEN LANE,
NEW YORK.

LUDWIG LEHMANN,

MANUFACTURER OF

JEWELERS' FINDINGS,

Paper Jewelry Boxes, Jewelers' Cards, Cotton of all Shades, a Rich Assortment of Cases in Plush, Velvet and Morocco.

Also Importer of the Celebrated Grass Bleached Tissue Paper, Mill 39.

Specialties:—Imitation Morocco Boxes and Cases, Plush and Satin Lined.

122 FULTON STREET, near Nassau, NEW YORK.

TEMPORARILY REMOVED TO 283 PEARL STREET.

HOPKINS' PATENT IMPROVED PIVOTING CHUCK,

WITH PUMP CENTER.

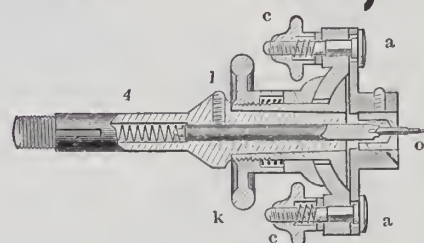
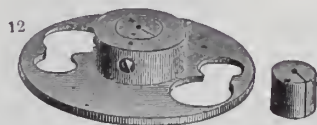
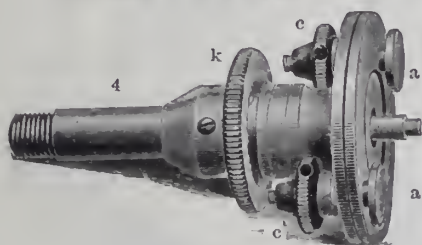

This Chuck, in accuracy of working, exceeds any other Chuck, either adjustable or self-centering, ever made, and is the only Chuck that, without the use of wax, will hold work to as perfect center and line as though held between dead centers.

HOPKINS WATCH TOOL CO.,

WALTHAM, MASS.

Send for full Descriptive Catalogue of our Manufactures.

ESTABLISHED 1810.

VACHERON & CONSTANTIN,

WATCH MANUFACTURERS,

GENEVA, SWITZERLAND.

These celebrated Watches and Movements are adjusted to Heat, Cold and Position. Movements Fitting ready made Stem-winding, Open Face and Hunting Cases of Waltham and Elgin Sizes.

SOLE AGENT IN UNITED STATES AND CANADA,

CHAS. LEO ABRY,

P. O. BOX 611.

63 NASSAU STREET, NEW YORK.

Design Patent No. 12,700, Washington, Feb. 2, 1883.



No. 1463.

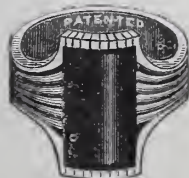

No. 1538.



Patented.

New York, February 15th, 1883.

Having obtained a Patent from the United States Government on above design of ring setting, we warn all dealers against buying or selling any ring infringing on above, as we shall protect our rights to the full extent in this matter.

We have taken the liberty of calling attention to this fact because an infringement is being made by certain parties. We therefore exhibit drawings so that you may know the design, in the manufacture of which we are protected by the government.

SINNOCK & SHERRILL, No. 3 MAIDEN LANE.



E. AUG. NERESHEIMER
& Co
IMPORTERS
of
DIA MONDS
21 MAIDEN
LANE
NEW YORK

NO 66 SARPHATI STRAAT
 AMSTERDAM HOLL.



Falkenau Oppenheimer & Co.
Importers of
Diamonds



40 Maiden Lane N. Y.

Post Office Box 3314.



Our friends will please notice that we have removed
our Establishment to above address.



OPPENHEIMER BROS. & VEITH,
 WATCHES,
 DIAMONDS,
 JEWELRY.

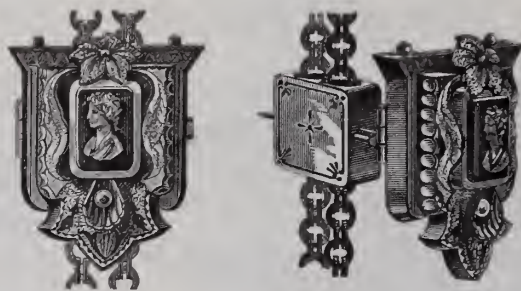

We are the Manufacturers and Patentees of the Combination Slide, Pendant and Locket, and the Combination Necklace, Lace Pin and Pendant.



We can furnish quite a variety of Styles, and are prepared to fill all Orders at once.

35 MAIDEN LANE, NEW YORK.



Our Catalogue of FRENCH MARBLE GONG CLOCKS is now ready, and will be sent to the trade ONLY on application.

LE BOUTILLIER & CO.,

Importers and Jobbers,

3 Union Square,

NEW YORK.

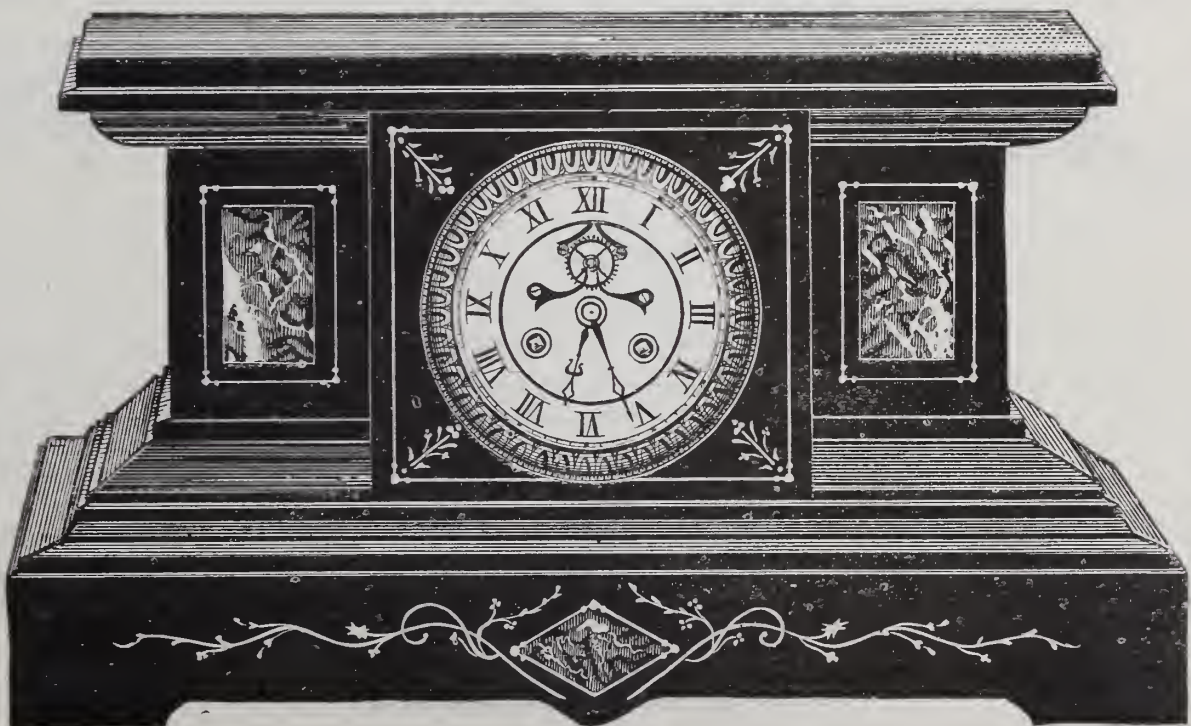

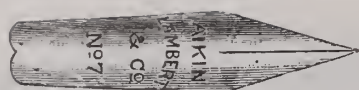

AIKIN, LAMBERT & CO.,

23 MAIDEN LANE, NEW YORK.

MANUFACTURERS OF

GOLD PENS, PENCIL CASES, HOLDERS, PENCILS, TOOTH PICKS

AND LATEST "NOVELTIES" IN PENCIL CHARMS.



NEW GOODS FOR SPRING TRADE.



"GRAVITY" PENCIL.

In addition to our Large Assortment of Gold Pen and Pencil Goods, we offer this season many *New* and *Novel* Patterns, all of our *Exclusive* Manufacture and Sale.



Our Line of Richly *Ornamented Engraved* Holders in all styles, suitable for Presentation purposes, show many Patterns *New* to the Trade.



New Styles of Pencil Charms in *Solid Gold*, *Silver* and *Rolled Plate*.



Our Line in Tooth Picks embraces the *Latest* Designs in *Solid Gold*, *Silver*, *Pearl*, *Celluloid* (Fancy and Plain) and *Plated*.



Goods Sent on APPROVAL when desired.

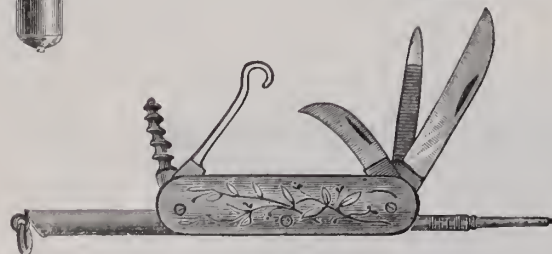

SEND FOR
Catalogue and Price List.



—:o ALSO IMPORTERS AND JOBBERS OF ALL GRADES OF o:—

WATCHES.

Including a Large Variety of *Desirable* Metal Cased Stem-Winders, and the *best* Low-Priced "Chronograph" Watch in the market.

Agents for *AGASSIZ* Movements fitting 8 and 16 Size Elgin Cases, and the *LONGINES* Movements fitting 18 Size Waltham Cases. Sole Agents for *PAUL BRETON* Celebrated Geneva Watches.

Jobbers of all kinds of *AMERICAN MOVEMENTS AND CASES*, including the Dueber and Keystone Silver Cases, and Boss' and Ladd's Filled Cases.

Manufacturers of *STONE RINGS*, all leading kinds, Band Rings, &c. Gold and Silver Thimbles, Plain, Chased, Octagon, &c. Bracelets, a large assortment in Gold and Plate. Gold and Plated Chains, Locketts, Seals, &c. A large variety of new and stylish Patterns in *GOLD* and *PLATED JEWELRY* are constantly being added to our stock. *Prompt attention to Orders and Repairs.*

JAS. C. AIKIN,
H. A. LAMBERT,
J. B. SHEA,
D. F. FOLEY.

Western Branch, 113 EAST MADISON STREET, CHICAGO, ILLS.

W. WESLEY MOORE

hopes to add to his many friends in Ohio, Tennessee, Arkansas, Kentucky, Missouri, Illinois, Iowa, Kansas, Nebraska, Colorado, New Mexico, Wyoming, Utah, Montana, Nevada, California, Arizona and Oregon.

NEW DESIGNS.

Mr. BRADLEY

will call at regular intervals in

Illinois, Wisconsin, Michigan, Minnesota, Dakota, Montana, Iowa and Indiana.

Headquarters, Chicago, - - Illinois.



J. L. CLARK

hopes to receive the favors of his patrons in New York, Massachusetts, Connecticut and Vermont.

We, the undersigned, representatives of the above well-known house, would announce to our respective friends that we will show them this Spring many new attractions, in addition to our usually large and varied stock.

We aim to merit your continued patronage and confidence.

Veru Respectfully,

J. C. ANDRESS

will continue to call on his friends in Maryland, Delaware, District Columbia, Virginia, W. Virginia, North Carolina, South Carolina, Georgia, Florida, Alabama, Mississippi, Louisiana, Texas Tennessee, Kentucky and Ohio.

W. Wesley Moore
Mr. Bradley
J. L. Clark
J. C. Andress
H. C. Barnum
H. S. Colyer

H. C. BARNUM

will renew his many acquaintances in Massachusetts, New York, Ohio, Indiana, Illinois and Michigan. Headquarters, Syracuse, - - - N. Y.

ATTRACTIVE GOODS.

FRESH STOCK.

LOW PRICES.

H. S. COLYER

will represent the house in Massachusetts, Maine, New Hampshire, New Jersey, Pennsylvania, Ohio and West Virginia.

CHARLES GLATZ,

MANUFACTURER OF

GOLD & SILVER WATCH CASES

WARRANTED

COIN



A SPECIALTY OF FULL WARRANTED 8 KARAT GOLD CASES,

Made in a Larger Variety than any other house, and Workmanship fully equal to the best in the Market.

JOBBER IN ALL AMERICAN MOVEMENTS.

We Call the Attention of the Trade to the Line of LOUIS XIV. Cases, in Gold and Silver, which we have Constantly on Hand.

10 MAIDEN LANE, N. Y. CITY.

EXCLUSIVELY FOR THE JOBBING TRADE.

LOUIS AUDEMARS'

CELEBRATED WATCHES.

PLAIN GENT'S STEM-WINDERS IN VARIOUS SIZES.

Also a FULL LINE of all the Complicated Styles of Watches made by this Distinguished House.

All Movements are Cased in the Very Best Manner.

J. EUGENE ROBERT,

SOLE AGENT,

30 MAIDEN LANE,

NEW YORK.

THE
E. HOWARD WATCH AND CLOCK CO.,
 —MANUFACTURERS OF—
Fine Stem-Winding Watches,
 FINE REGULATORS, OFFICE CLOCKS, TOWER CLOCKS,
And Electric Watch Clocks.



LADIES'
6 Size.

STEM-WINDING
AND



GENT'S
16 Size.

Stem-Setting
Movements.



GENT'S
18 Size.

114 TREMONT ST., BOSTON.

29 MAIDEN LANE, New York.

J. W. J. PIERSON, Agent.



WILLEMIN WATCH CASE CO.,

109 Sands Street, Brooklyn, N. Y.

In response to numerous enquiries respecting prices of our Cases, would say that we have made no change from prices of last year.

We do not care to compete with houses whose productions are but little better than Blacking Boxes. The Willemmin Case is strictly hand made, and are not Engine Turned by Steam-power Lathes.

The E. Howard Watch Co. use our cases exclusively, which fact is a sufficient guarantee of their superior style, quality and finish.

MATHEY BROS. & MATHEZ,

NO. 16 MAIDEN LANE.

IMPORTERS OF ALL GRADES OF

Plain and Complicated Watches and Movements

SOLE AGENTS FOR THE WELL-KNOWN

H. L. MATILE

Fine Watches of Astronomical Precision.



REPEATERS.



CHRONOGRAPHS.

In order to facilitate the handling of our Stem-Winding Movements, we have adopted a standard of sizes to fit American Cases. Of these we have a complete line from the medium grade to the highest class goods of fine adjustment and precision. As all our Movements, complicated and plain, are perfectly uniform in quality according to their respective grades, we can furnish material for any parts that may be required, with the positive assurance of accurate interchangeability.

CHRONOGRAPHS.

WATCHES DEMAGNETIZED.

TENTH AND CHESTNUT STREETS, PHILADELPHIA.

MORGAN & HEADLY,

MANUFACTURERS OF

↳ GOLD, SILVER AND STEEL ↳

EYE-GLASSES & SPECTACLES.

OUR TRADE GROWS Apace.

We are constantly improving our Patterns and Machinery, and Educating our Employees, thereby advancing the standard of our business.

The coming season will prove us to be still going ahead in our Special Line. With more extensive Stock and Facilities, and everything advanced except Prices, which are uniformly low, we invite a continuance of your patronage.

IMPORTERS OF DIAMONDS.

Keeping a full assortment, including matched pairs of fine quality, which we will send to the trade on memorandum, at low prices, on receipt of satisfactory reference.

MORGAN & HEADLY, Tenth and Chestnut Streets, Philadelphia.

ROGERS, SMITH & CO.,

MANUFACTURERS OF

Electro Gold
AND
Silver Plated
Ware.



SALESROOMS :

46 EAST 14th STREET,

UNION SQUARE, N. Y.

FOR THE TRADE ONLY.

FACTORY, - - - - MERIDEN, CONN.

FINISHED WATCH MATERIALS

For all Grades and Sizes of the Celebrated Longines and Agassiz Movements, can be obtained from all the Principal Jobbers and Watch Material Dealers throughout the country.

J. EUGENE ROBERT,

30 MAIDEN LANE, NEW YORK.

AND INTERCHANGEABLE PARTS.

LONGINES,

AGASSIZ,

ESTABLISHED 1844.

DENNISON MFG CO.,

BOSTON, NEW YORK, PHILADELPHIA, CHICAGO, CINCINNATI AND ST. LOUIS.

JEWELERS' FINDINGS.

PAPER JEWELRY BOXES IN ALL STYLES AND QUALITIES. IMITATION MOROCCO BOXES, SATIN LINED. TAGS, JEWELERS' CARDS, PINK AND WHITE COTTON, &c., &c.

MOROCCO CASES.

Manufacturing in our own Shops Every Description of Morocco, Plush and Velvet Jewelry and Silverware Cases in large quantities, we are enabled to sell lower than other goods of equal quality can be offered, and we carry in all our Stores FULL Stock of our whole line.

Catalogue on Application.

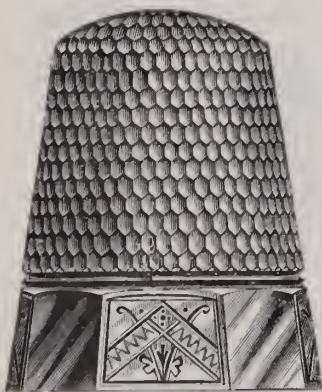

13 Maiden Lane,
NEW YORK.

FRANK S. KENNEDY,

Manufacturer and Wholesale Dealer in

JEWELRY

OF EVERY DESCRIPTION.



13 Maiden Lane,
NEW YORK.

In addition to my stock of Jewelry, which is complete in all lines of Gold, Silver and Roll Plate, I am now making a Full Assortment of

THIMBLES,

in Solid Silver, 10 karat and 14 karat Gold. These Thimbles are Superior in Finish to any now in the market, and are as near perfection as long practical experience can make them. Will send Samples if desired.

The Assortments of Jewelry I send on Memorandum for Special and Stock Orders have an increasingly high reputation.

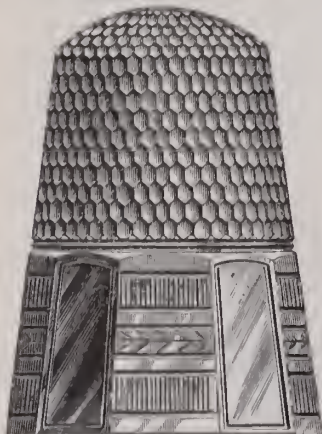

KREMENTZ & CO.

GOLDSMITHS,

No. 192 BROADWAY,

NEW YORK.



We offer for this Season's Trade a Full
Assortment of

DIAMOND, PEARL, ONYX, CAMEO & ROMAN GOLD JEWELRY

NOVELTIES IN LADIES' AND GENT'S RINGS.

ALSO A LARGE VARIETY OF DIAMOND MOUNTINGS,
ALL GOODS OF OUR OWN MANUFACTURE.

JOHN A. RILEY & CO.,

Nos. 7 and 9 Bond Street, New York,

Manufacturers of the PATENT SPRING BRACELETS,

Patented Oct. 25th, 1876; Nov. 12th, 1878; June 29th, 1880.
Reissued June 1st, 1880.

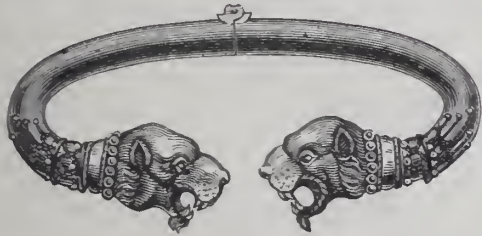

3284.

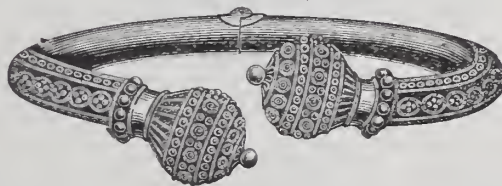

3432.

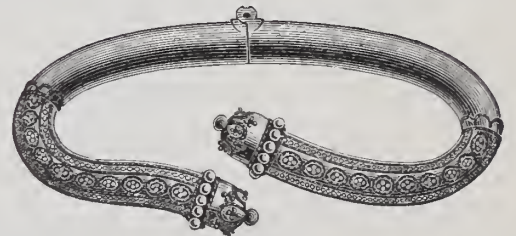

3418.

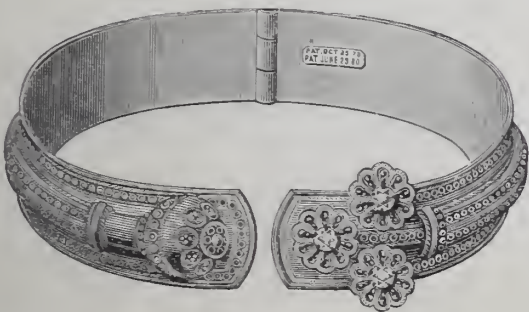

3755.

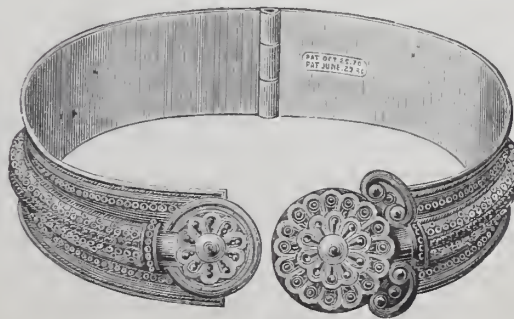

3753.



3694.

Rich Gold Jewelry, Novelties in Half Sets, Lace Pins, Scarf Pins, Ear Rings and Brooches, Engagement Padlock Bands and Hoop Ear Rings.

GOODS SENT ON MEMORANDUM TO RESPONSIBLE DEALERS.

☞ ALL GOODS ARE OF OUR MANUFACTURE AND 14 KARAT FINE. ☜



GEO. H. RICHARDS, JR.,
 383 WASHINGTON STREET,

BOSTON, MASS., U. S. A.



AMERICAN MOVEMENTS AND CASES A SPECIALTY.

We Guarantee to have ALL GRADES in Stock.

MOVEMENTS.

WALTHAM.

SPRINGFIELD, ILLS.

HAMPDEN.

ELGIN.

HOWARD.

→: CASES. :←

❖GOLD❖

❖FILLED❖

❖SILVER❖

WALTHAM.

"BOSS."

WALTHAM.

DUEBER.

CROWN.

DUEBER.

BROOKLYN.

LADD.

FAHYS.

G. H. R., Jr.

KEYSTONE.

Watches, Jewelry and Silver Plated Ware. Rogers & Bro.'s Flat Ware.

HOLLOW AND FLAT WARE SOLD AT MANUFACTURERS' DISCOUNTS.

Our Stock is positively the Largest, Finest and Best Assorted of any Jobbing House in the Country. All Orders Promptly Executed.

GEO. H. RICHARDS, Jr., 383 Washington Street, Boston, Mass.

ANNOUNCEMENT.

The New Price List for complete 3-4 plate, 8, 14 and 16-size Gold Watches, issued under date of February 1st, 1883, by the American Watch Co., of Waltham, is now ready for distribution. We will forward a copy upon application, accompanied by business card, from any regular dealer in watches.

Jobbers who wish copies sent to their customers will please notify us by sending the names and addresses of the same, but such customers must be regular Watch Dealers. We shall take special precaution in the distribution of this list, in order to keep it out of the hands of the general public, and we beg to request that the Trade will co-operate with us in this undertaking, it being entirely in their interests.

We also beg to call particular attention to the fact that the cases quoted in this list are entirely of our own manufacture, and that we are directly responsible for the quality of the same.

By 18 K. or 14 K. or 10 K. we mean 18 K. or 14 K. or 10 K., and not 16½ K. or 12 K. or 8 K. We offer you actual value for your money.

ROBBINS & APPLETON,

NEW YORK:

5 BOND STREET.

BOSTON, MASS.:

403 WASHINGTON STREET.

CHICAGO, ILL.:

170 STATE STREET.

LONDON, ENGLAND:

HOLBORN CIRCUS.

AUSTRALIA:

SYDNEY, NEW SOUTH WALES.

H. MUHR'S SONS,
PHILADELPHIA.

Important Announcement.

We have signalized the Opening of the New Year by making an
IMPORTANT REDUCTION
IN THE PRICE OF

CROWN FILLED CASES

In connection with this step, we take pleasure in announcing to the Trade that we have recently acquired ENTIRE CONTROL OF THE FACTORY, AND ARE NOW CONDUCTING THE PRODUCTION OF THE FILLED CASES UNDER OUR IMMEDIATE SUPERVISION, which fact enables us to offer the Improved Crown at better value than any Filled Case ever before placed upon the market.

The gold contained in Crown Cases, which are now being turned out under our supervision, IS FULLY EQUAL TO THAT OF ANY FILLED CASE ON THE MARKET.

This fact can be attested to the satisfaction of any dealer, who will go to the trouble of having one of these cases assayed, with one of corresponding size and style of ANY OTHER MAKE.

The United States Mint, at Philadelphia, will make a complete assay for the sum of one dollar each, and we will return a new case to the dealer in place of the one of our make destroyed, upon the receipt of the Assay Certificates and the gold contained in the Crown Case assayed.

Solid Gold Joints. Solid Gold Plugs.

CROWNS SAME AS USED IN SOLID GOLD CASES.

GOLD the Natural Color, absolutely no GILDING.

New York Office:

1½ MAIDEN LANE.

Chicago Office:

137 STATE STREET.

IMPROVED CROWN FILLED CASE.



Raised Gold Ornamentation.

SOLID

RAISED GOLD

ORNAMENTATION.



Raised Gold Ornamentation.

This feature, in connection with FILLED CASES, is entirely new; the Improved Crown, thus far, being the ONLY Filled Gold Case upon which this unique and attractive style of embellishment has ever been SUCCESSFULLY and ARTISTICALLY applied. Several new designs have recently been added; others will be announced soon.

On our regular line of ENGRAVED CASES we offer the Largest Variety of Original, Beautiful and Artistically Executed Designs ever presented to the Trade.

SOLD BY ALL LEADING JOBBERS.

H. MUHR'S SONS,

PHILADELPHIA.



Raised Gold Ornamentation.

NEW YORK OFFICE,
1½ Maiden Lane.

CHICAGO OFFICE,
137 State Street.



Raised Gold Ornamentation.



1380

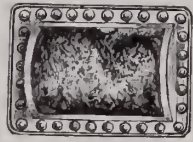

1162



1687



93



1476



0027



864

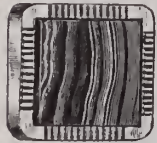

1206



1479



0041



1234



0024



1420



1369



1239

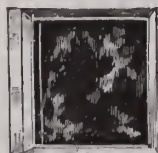

1321



1235



1340



017



93



02

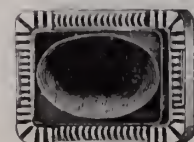

1182



634

THE ACME LEVER BUTTON



OPEN.



CLOSED.



OPEN.



OPEN.



CLOSED.



CLOSED.



1257



1582



0025



1003



0200

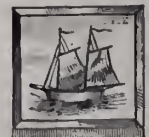

869



1457



1269

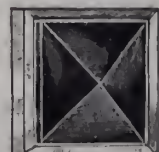

1502

KELLER & UNTERMAYER,

No. 9 Maiden Lane, New York,

MAKERS OF

ARTISTIC GOLD WATCH CASES,

Have secured the exclusive right to manufacture Gold, Silver and Filled Inlaid Decorated Cases under W. C. Edge's improved methods, secured by Letters Patent.

Heretofore the beautiful effects produced by inlaying one metal with another have only been reached at a great expenditure of labor and time. Mr. Edge has devised a new process for producing inlaid work, which not only materially reduces the cost, but gives more effective results. It consists in intimately connecting the metals desired to be used in slices, and then, by an embossing process, bringing the lower slices into the plane of the upper ones, where they can be worked as desired.

Many New and Attractive Designs, Rich and Unique in Ornamentation, are now ready, and are, without exception, the

❖ Most Artistic Watch Cases Made. ❖

1883

Without a Rival.

JAS. BOSS' PERFECTED GOLD WATCH CASE.

SOLID GOLD BOW.

New and Exceedingly Fine Full Engravings.

The great success of this NEW Case is to be attributed to the fact that to it is applied the same TALENT that is to all the products of the Keystone Factory, and so it is the common saying,

"It Beats the World!"

MANUFACTURERS
 OF THE
 JAS. BOSS' PATENT PERFECTED GOLD

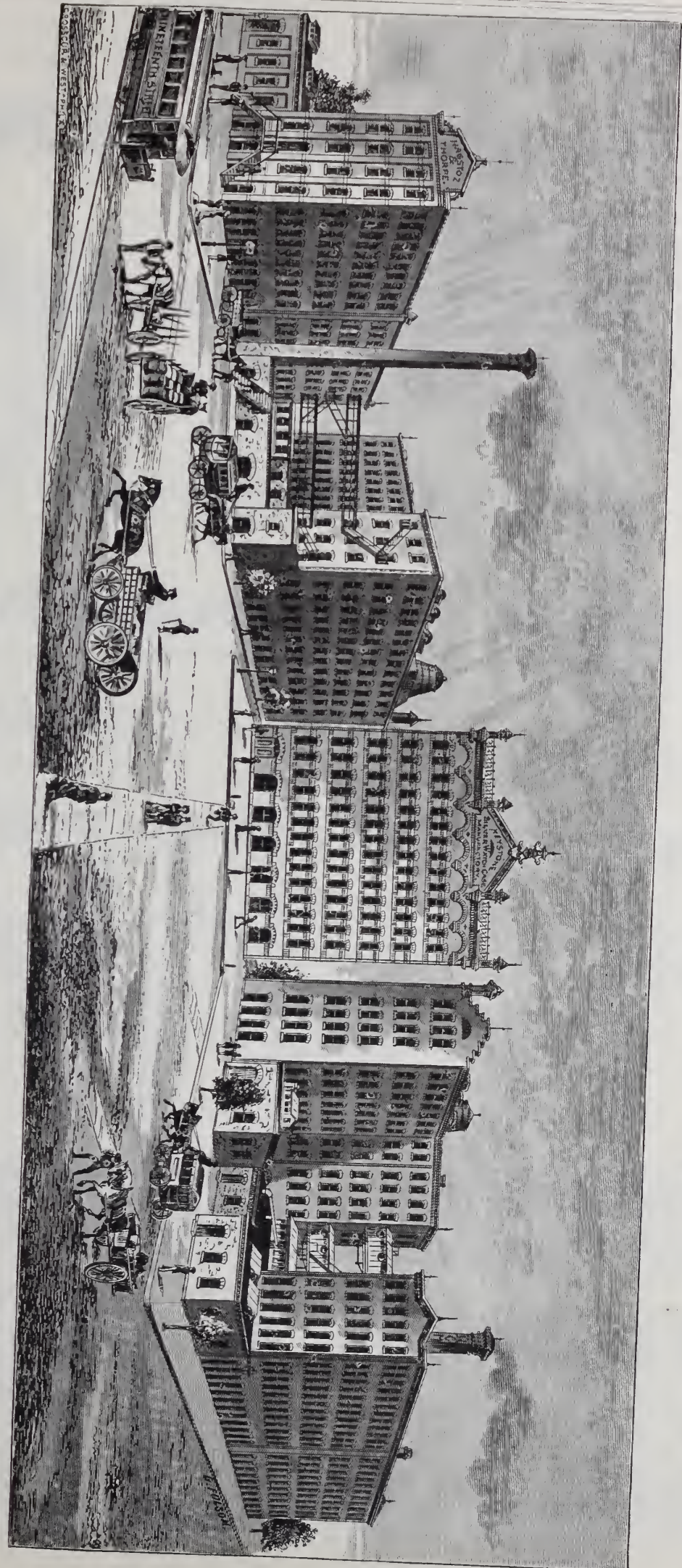

AND

KEYSTONE IMPROVED COIN SILVER WATCH CASES.

LOUIS KAHN.

MOSES KAHN.

SAMUEL H. LEVY.

I. W. FRIEDMAN.

L. & M. KAHN,

IMPORTERS OF

Watches, Diamonds & Precious Stones,

10 MAIDEN LANE, NEW YORK.

11 Corrairie, Geneva, Switzerland.

17 Rue de Chateaudun, Paris.

WATCHES,

Stem and Key-Winding, from the Lowest Priced Nickel and Silver to the Finest Gold and Complicated.

A Full Assortment of these Goods always in Stock.

DIAMONDS,

Loose and Mounted, in all Sizes and Qualities.

Gold, Silver, Nickel and Celluloid Chatelaines in Great Variety.

STANDARD DUST-PROOF WATCH KEYS.

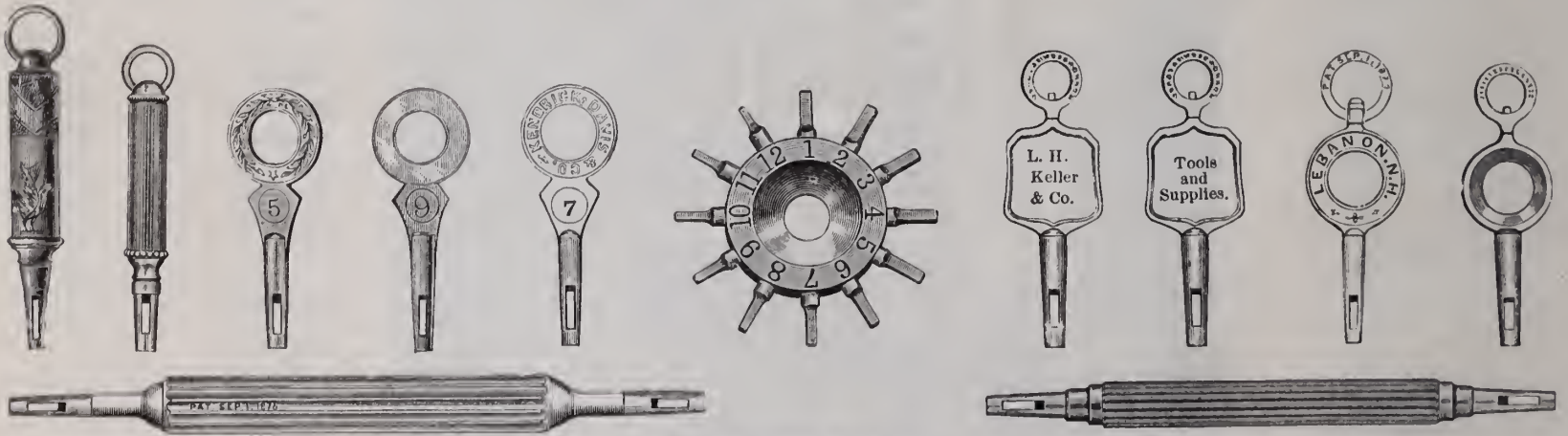

FOR SALE BY

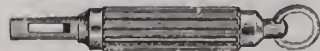

THE TRADE.

KENDRICK & DAVIS,

Sole Owners and Manufacturers, Lebanon, N. H.

ILLUSTRATED CATALOGUE AND PRICE LIST SENT ON APPLICATION.

"The Waterbury." The New "Series B,"

With FULL DIAL and SOLID PLATES.

NEW SERIES B.
Bezel Off,
Showing Index Plate and Regulator.



NEW SERIES B.
Solid Plates and Full Dial.

In this new SOLID PLATE movement the position of the regulator has been changed; it will be found projecting beyond the plate, immediately under the bezel. The FULL DIAL enables the position of the hands to be readily seen.

The danger of injuring the Hair Spring in regulating is obviated in this new movement.

SERIES A.—Open Dial, Skeleton Plates, - - \$48.00 per doz.
SERIES B.—Full Dial, Solid Plates, - - - 48 00 "

Discount to the Trade.

We can supply either Pattern as ordered.

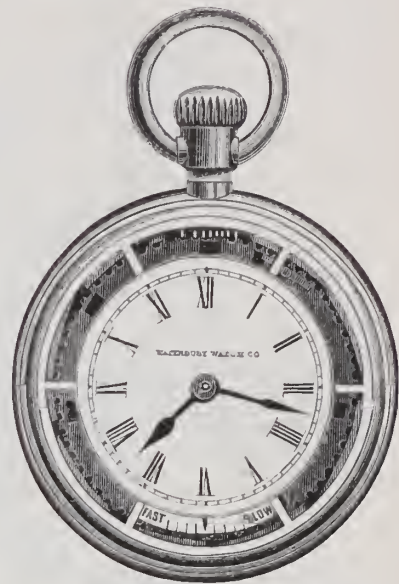

WATERBURY WATCH CO.,
WATERBURY, CONN.

NEW YORK OFFICE, 4 MAIDEN LANE.

GEO. MERRITT, GENERAL SELLING AGENT,

To whom all Orders and Correspondence as to Prices and Terms should be addressed.

FOR SALE BY DEALERS GENERALLY.

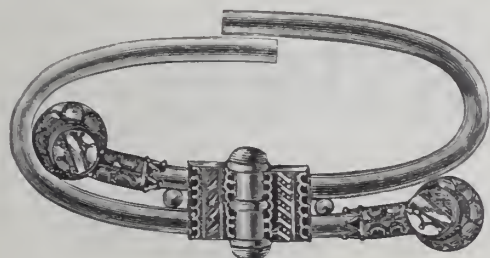

225

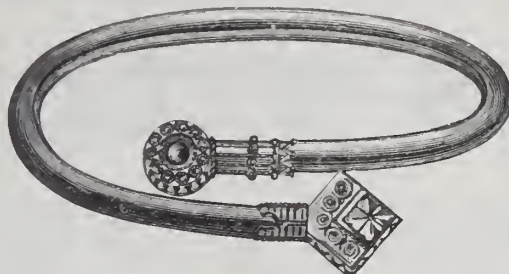

214

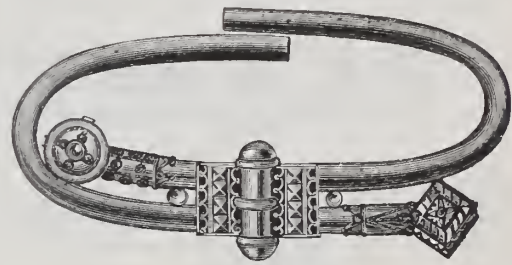

222

ELLISON & VESTER'S
PATENT

BAND AND BANGLE FINE ROLLED PLATE
BRACELETS,

For Sale by Every Jobber.

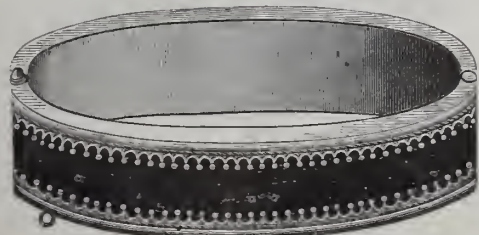

179

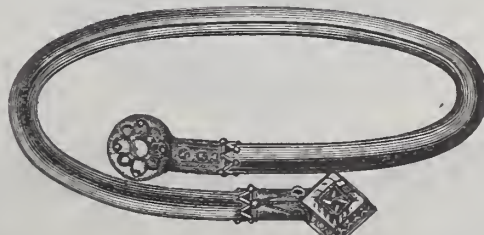

213

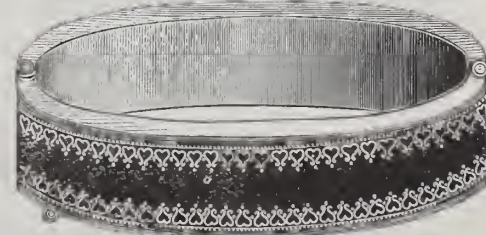

178

L. A. CUPPIA,

Manufacturing Jeweler,

19 Union Square, N. Y.

SILVER CANE HEADS,

A Large and Comprehensive Assortment of New and Original Designs.

AND IMPORTER OF



Embracing a Large and Varied Assortment of Popular Designs.



SILVER BRACELETS A SPECIALTY.

SELECTION PACKAGES SENT ON APPROVAL.

CLEMENS HELLEBUSH,

MANUFACTURER, IMPORTER AND WHOLESALE JEWELER,

Dealer in everything required by the Jewelry Trade.

DIAMONDS.—Dealers will find in my stock an assortment of Diamonds unequalled in the West, embracing a choice variety of loose and mounted Stones in all qualities.

WATCH CASES.—In Gold and Silver, of all makers, to fit American Movements.

WATCH MOVEMENTS.—Include always a full stock of Waltham, Springfield, Hampden and Howard, together with a large assortment of fine and low-priced Swiss Watches.

SILVER PLATED WARE.—I have an unusually fine assortment of the choicest patterns of Flat and Hollow Ware of the best known manufacturers.

SOLID GOLD AND ROLLED PLATE JEWELRY.—This department is replete with Staple Goods and Novelties.

FRENCH CLOCKS.—Of our own importation, including all grades, with prices exceedingly low.

AMERICAN CLOCKS.—I am the General Agent in Cincinnati for the celebrated Seth Thomas Clocks, a full line of which will always be found in stock.

TOOLS AND MATERIALS.—In this department will be found everything required by Watch Makers.

Illustrated Catalogues sent to Dealers only upon Application.

CLEMENS HELLEBUSH,

77 West 4th Street,

CINCINNATI, O.

STANDARD WATCH CO.



STANDARD CALENDAR

"STANDARD CALENDAR."

20 Line, Open Face, in Nickel and Silver, showing the date and day of the week. Full Jeweled, Finished Movement. The Latest Novelty offered.

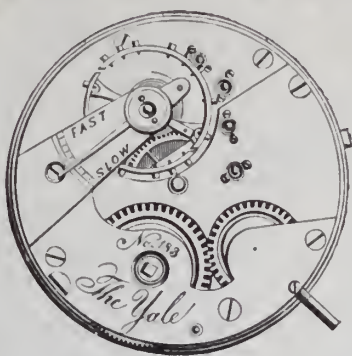

"THE YALE."

18 Size, will fit Waltham Cases.



"THE JUNO."

Ladies' 8 Size, Full Jeweled, fits Waltham Cases



"STANDARD."

8 Size, Full Jeweled, Ladies. Fits Waltham Cases.



REGISTERED.



"STANDARD."

Nickel, 17, 19 and 20 Line. Lever, Full Jeweled.

Max Freund & Co., Sole Agents, 8 Maiden Lane, New York.

All practical men who critically examine these Cases acknowledge this Process of Manufacture to be far superior to all others in all important features which constitute the Best Watch Case.

LADD PATENT
STIFFENED

GOLD WATCH CASES.

Sold by the Leading Jobbing Watch and Jewelry Houses at the Manufacturers' Wholesale Prices.



Design No. 588, in Flat.



Design No. 591, in Oval.



Design No. 593, in Flat.

THE STANDARD SINCE 1867.
FOR BEAUTY OF DESIGN AND ORNAMENTATION.
FOR STRENGTH OF FRAME AND COVERS. FOR SUPERIOR WORKMANSHIP.
FOR SATISFACTION THEY HAVE GIVEN IN WEAR AND DURABILITY.



GILES, BRO. & CO.

Wholesale,
Importing and
Manufacturing

→ JEWELERS, ←

Cor. State & Washington Sts.,

CHICAGO, ILLS.

Complete Illustrated Catalogue Furnished the
Trade upon Application.

LANCASTER WATCH CO.

MANUFACTURERS OF

A. BETNER'S
Patent.

DUST PROOF WATCHES,

Patented
Nov. 28, 1882.

Fine Nickel and Gilt Stem-Winders.

These Watches meet a want long felt by the Trade generally. The balance being entirely closed meets the point taken by Jurgensen in his remarks upon the Resistance of the Air, as found in the CIRCULAR AND REVIEW, January No., 1883, page 414. This movement is guaranteed to be Dust-Proof, no matter in what case it may be placed. It is interchangeable with our regular case, or can be put into the Regular 18-size cases in the hands of Jewelers or Watch Dealers everywhere.

FOR SALE BY LEADING JOBBERS THROUGHOUT THE UNITED STATES.

ESTABLISHED 1869.

THE JEWELERS' CIRCULAR AND HOROLOGICAL REVIEW,

THE RECOGNIZED ORGAN OF THE TRADE.

SUBSCRIPTION TO ALL PARTS OF THE UNITED STATES AND CANADA, \$2.00 PER ANNUM.

1883.

The XIV Volume of "THE JEWELERS' CIRCULAR AND HOROLOGICAL REVIEW" began with the FEBRUARY ISSUE, and will surpass in interest all previous Volumes.

E. E. KIPLING,
 — IMPORTER OF —
PRECIOUS AND IMITATION STONES,
No. 6 Maiden Lane, New York.

For the protection of the trade I find it necessary to issue the following **TRADE MARK.**

Very Important to Jobbers and Retail Jewelers.

In buying White Stone Jewelry, be sure to get "Patent Foil Solid Metal Back Rhine Stone Brilliant." The Cards must be stamped as above. The advantages over the PAINTED FOILS ARE:



- They are more Durable.
- " are not affected by washlog or dampness of air.
- " retain their Lustre.
- " preserve their Purity of Color.
- " are sold at the same price as the Painted Foils.
- " are sure to give satisfaction.

which will hereafter be embossed or printed on all cards containing Jewelry in which is set my Patent Foiled Solid Metal Back Rhine Stone Brilliants, in place of the below stamps, which were formerly employed and which have been **ABOLISHED.**

See that all the Jewelry Cards are Stamped with my Trade Mark.

All violations of my rights, whether under my patent or my trade mark, will be prosecuted to the full extent of the law.

My customers are respectfully requested to inform me of any infringements that may come to their knowledge, so that I may be the better able to protect them from unlawful competition.

PATENT FOILED SOLID METAL BACK
 RHINE STONE BRILL'S,
 PATENTED FEB. 28, 1882.

PATENT FOILED SOLID METAL BACK
 RHINE STONE BRILL'S
 PAT. FEB. 82.

PATENT FOILED
 SOLID METAL BACK
 RHINE STONE BRILL'S.
 PAT. FEB. 28, 82.

All Jewelry containing my Patent Foils, made after this date, will bear my **TRADE MARK.**

E. E. KIPLING.

J. M. CHANDLER & CO.,

—MANUFACTURERS OF THE—

PATENT EMBOSSED BRACELET.



These cuts represent examples of one of the many styles of our New Patent Embossed Bracelet.



Chain Bracelets either in Gold or Plate are necessarily weak, as a small rivet is used to connect the links; when one rivet fails, the whole comes apart. The Embossed Bracelet is an exact imitation of a chain made from a solid piece of stock by a patent process, and while the goods are of the best quality, the price is much lower.

The stock from which these goods are made is plated in our factory, and we **GUARANTEE** each and every pair to wear and give satisfaction. They are adjustable and will fit any arm.

We will send Selection Packages of the Goods to Dealers on Approval.

ADDRESS ALL ORDERS TO

J. M. CHANDLER & CO.,

JOBBER IN ALL KINDS OF

CLOCKS, WATCHES, JEWELRY, AND ALL KINDS OF TOOLS AND MATERIALS,

185 Superior Street, Cleveland, O.

TRADE MARK



Of Our Plain Filled RINGS.

STERN BROS. & CO.

Manufacturers of

FINE

JEWELRY.

Gold and Silver Thimbles,

STONE RINGS & LOCKETS A SPECIALTY.

30 Maiden Lane, New York.

Factory, 17 and 19 John Street.

GOODS SENT ON SELECTION TO RESPONSIBLE PARTIES.

The special attention of the trade is directed to our

Plain Gold Oval and Flat Filled Rings.

Cut Sections showing their construction mailed upon application.

Birch's Patent Self-Adjusting Watch Keys.

FOR SALE BY THE TRADE GENERALLY.



2.—POCKET KEY.
(Brass.)



3.—POCKET KEY.
(Nickel Plated.)



4.—POCKET KEY.
(Nickel Plated, Hexagon Shell.)



5.—POCKET KEY.
(Heavy Rolled Gold Plate Mountings.)



6.—CELLULOID MOUNTED KEY.
(With Heavy Rolled Gold Plate Tips.)



35.—POCKET KEY.
CELLULOID MOUNTINGS.
(Imitation Malachite, with Extra Heavy Rolled Gold Plate Tips. 18. K.)



7.—BENCH KEY. (Brass Handle.)



8.—SHORT WOOD HANDLE KEY.
(Nickel Plated, for Bench or Pocket Use.)



9.—LONG WOOD HANDLE BENCH KEY. (Nickel Plated.)

Made in 37 Styles. Circulars on Application.

J. S. BIRCH & CO., 38 Dey Street, N. Y.

THE

LIGHTENING

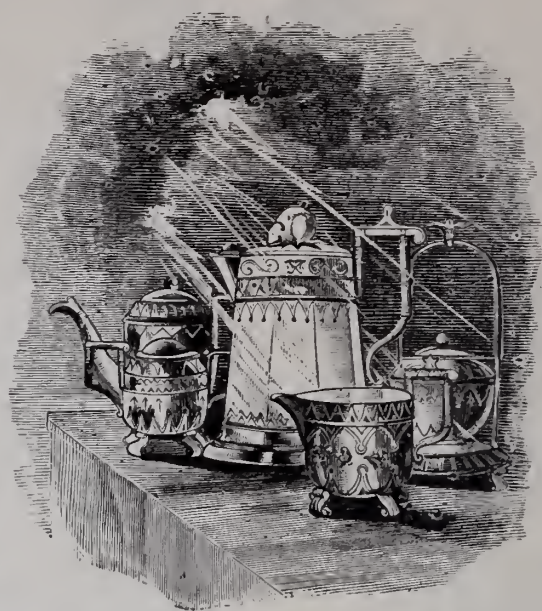

CLEANSER

FOR ABSORBING TARNISH

FROM GOLD, SILVER PLATED WARE, CHASED GOODS AND NICKEL.

The striking peculiarity of this "CLEANSER" is that it does its work by absorption, and does not require rubbing and labor to get the article cleansed.

It contains no Poison, Acid or Alkali (including Ammonia and Cyanide), and is warranted to give entire satisfaction or money refunded.

MANUFACTURED BY

W. M. SCOTT & CO., Philadelphia, Pa.

And for Sale by Jobbers and Manufacturers of Silverware.

Price Per Gross reduced to \$12.00; or One Dozen sent, post paid, to any address in the United States on receipt of \$1.50; or One Package 25 Cents.

BARNES'

NO. 4 LATHE,

For the Heavier Work of Jewelers.

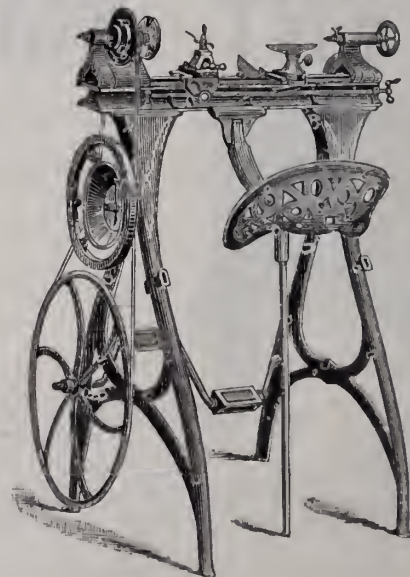

Barnes' Patent Foot and Steam Power Machinery. Complete outfits for Actual Workshop Business. Lathes for wood or metal. Circular Saws, Scroll Saws, Formers, Mortisers, Tenoners, etc., etc. Machines on trial if desired. Descriptive Catalogue and Price List Free.

W. F. & JOHN BARNES,

2088 Main Street, ROCKFORD, ILL.

THE JEWELERS' CARD AND TAG CABINET,

Patented Jan. 23d, 1883.



A new and useful device for the keeping of Cards and Tags, is so constructed to accommodate the various sizes of cards, which can be found at a glance when wanted. It is neatly finished and a most convenient thing for Jewelers. As every Jeweler must be aware that he is annually wasting a certain amount of cards for want of a proper place for keeping of same. All Jewelers are obliged to keep a certain amount of

Cards and Tags; these are kept in some drawer and when wanted are generally found scattered about and soiled so as to make them unfit for use. Cards kept in this Cabinet are always clean and cannot get soiled, which is of the greatest importance. When closed the Tag Tray will fit over all cards, and top of Cabinet closing up over the Tag Tray; this, when closed, will prevent the dust from penetrating into the Cabinet. The price of this new and useful device is so low that the smallest dealer will not do without it, as it will repay him in a short time by the saving of cards. This Cabinet can also be used for various other purposes in connection with Cards and Tags.

Will be forwarded to any part of the United States or Canada on receipt of . . . \$1.00.
Filled with Cards and Tags, . . . 4.50

ADDRESS

S. WIESBAUER & CO.,

414 MAIN ST., BUFFALO, N. Y.

ALSO FOR SALE BY LEADING JOBBERS.

WM. M. FISHER & CO.

Sole Manufacturers of the



PATENT INTERCHANGEABLE
Combination Necklace,
And Ladies' Brooch or Lace Pin

GOLD
AND
SILVER
CHAINS.

Gold Chain
TRIMMINGS.

Complete
Assortment of

14-k.

Ribbon Fobs.

FOR SALE BY THE LEADING JOBBERS

The Burbank Manufacturing Company

Manufacturers of GOLD & SILVER



Thimbles,



SPECTACLES AND EYE-GLASSES



OF ALL DESCRIPTIONS.

SOLID GOLD RINGS

Office, 14 MAIDEN LANE. NEW YORK.

Manufactory, Springfield, Mass.

PETER B. SIMONS & CO.,

MANUFACTURERS AND IMPORTERS OF

FINE JEWELRY,

GOLD CHAIN,

Gold and Silver Thimbles, Canes, Sets, Etc.,

FOR THE TRADE ONLY.

No. 120 SUTTER STREET,
SAN FRANCISCO.

FACTORY:
611 & 613 SANSOM STREET,
PHILADELPHIA.

SALESROOM:
120 SUTTER STREET,
SAN FRANCISCO.

DEALERS IN AMERICAN AND IMPORTED

❖ GOLD ❖ AND ❖ SILVER ❖ WATCHES. ❖

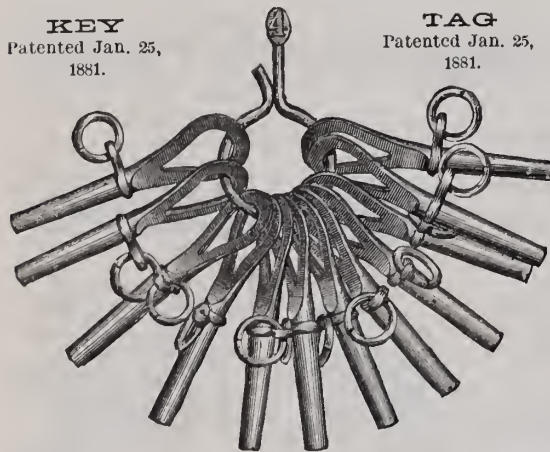

KEY
Patented Jan. 25,
1881.

TAG
Patented Jan. 25,
1881.

A. N. CLARK
PLAINVILLE,
CONN.,

Manufacturer of

Watch Case Springs, Watchmakers' & Jewelers' Bench Tools,
CROSBY'S JEWELING TOOLS, &c.

STOP IMPORTING KEYS!

For Low Price Key Use the

New Style Loop Key.



A plain Steel Key of good appearance, and excellent quality. It will not wear the pocket. It has a swivel, and is much better made than the imported plain steel or iron keys.

PRICE PER CROSS, FINE NICKEL FINISH, \$2.25
Postage, 10 Cents Per Cross Additional.

This Key is good and cheap enough to become universal. Send business card for illustrated price list. Enclose three cent stamp for sample key.

SOLD BY JOBBERS IN WATCH MATERIALS AND NOTIONS.

A. N. CLARK, Plainville, Conn.

PATENT CANE CASE.

Certain parties having infringed on our Patent for this most desirable Case, we now give notice that they can hereafter only be procured from us with safety.

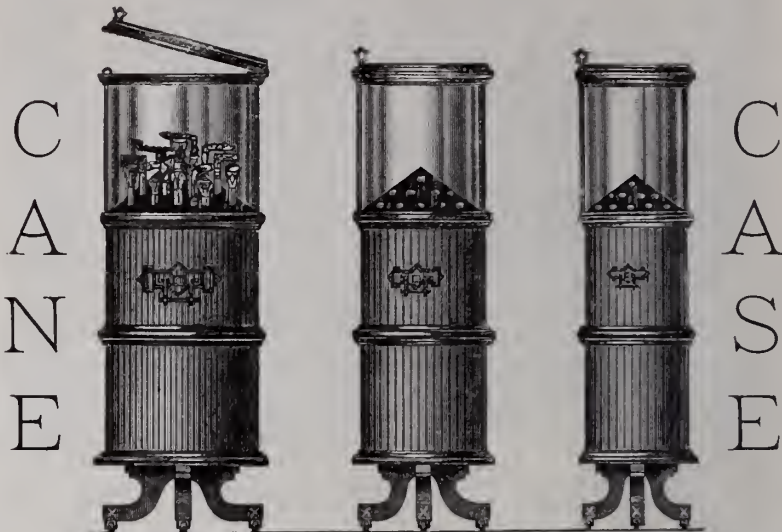

GOLD, SILVER and COPPER HEAD CANES in New Designs and Applied Work, in Greater Variety than can be found elsewhere.

SIMONS, BRO. & CO.,

611 & 613 Sansom St., PHILADELPHIA.
MANUFACTURERS OF

Cane Heads, Gold Chain, Bracelets, Thimbles and Fine Jewelry.

AMERICAN WATCH TOOL CO.,
WALTHAM, MASS.

P. O. Box 909.

Manufacturers of the Whitcomb Lathe, and Machinery for Watch, Watch Case and Clock Making.

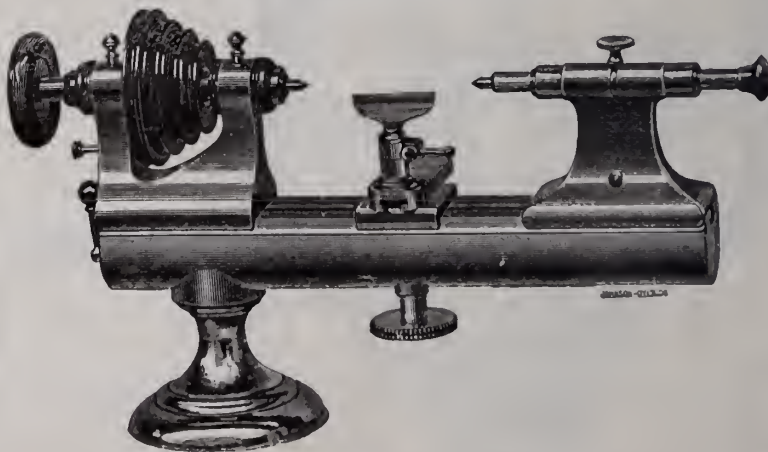

SEND FOR NEW CATALOGUE.

Our No. 1 1/2 Lathes are Fast Superceding all other Sizes.

Soft Lathes have Hard Mouths, Hard Wire Chucks and Hard Tail Stock Spindles.

Revised PRICE-LIST Just Issued.

R. & L. FRIEDLANDER,

PRINCIPAL SALESROOMS,

65 & 67 Nassau Street, N. Y.

Branch, 264 Bowery—Factory, 50 Bond Street.

IMPORTERS OF

WATCHMAKERS' AND JEWELERS' SUPPLIES

AND OPTICAL GOODS.

We keep on hand a fine line of Rare Material not to be had from other importers, and patrons can rely upon securing what they order, since all our Material orders are selected by experienced watchmakers. We have also a complete stock of everything in the Optical line, such as Spectacles, Eye-Glasses, Field Glasses, Telescopes, Barometers, Etc., Etc.

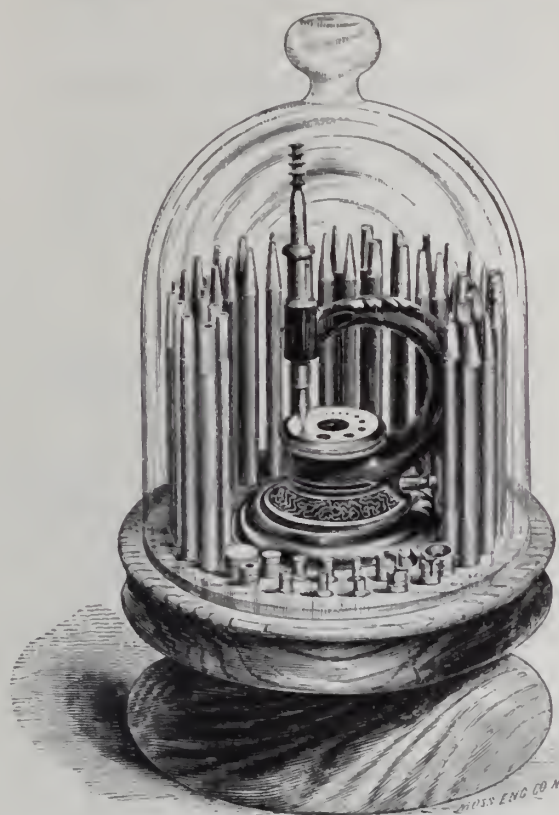

Staking Tool, \$13.50.

Address Communications to 65 and 67 Nassau Street, New York.

FOR SALE BY ALL JOBBERS.

FOR SALE BY ALL JOBBERS.

FOR SALE BY ALL JOBBERS.

THE P. O. D.

ROLLED GOLD

Vest Chain, Charm and Key.

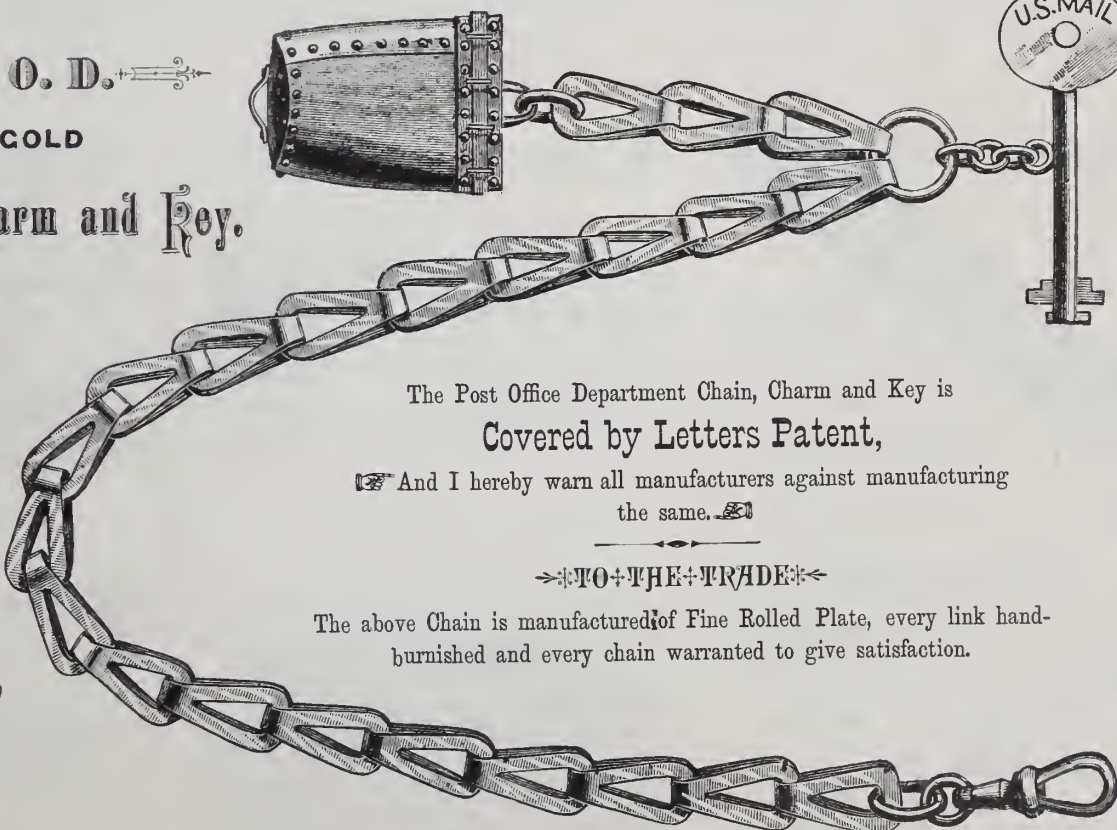
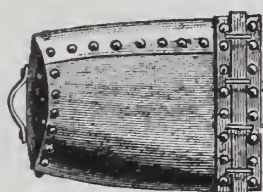

The Post Office Department Chain, Charm and Key is Covered by Letters Patent,

And I hereby warn all manufacturers against manufacturing the same.

TO THE TRADE

The above Chain is manufactured of Fine Rolled Plate, every link hand-burnished and every chain warranted to give satisfaction.

C. W. LITTLE,

Patentee,

324 & 326 FIFTEENTH ST.,

DENVER, COLORADO.

FOR SALE BY ALL JOBBERS.

NEW YORK OPTICAL CO.,
Manufacturers of all kinds of
Spectacle Lenses, Spectacles,
—Eye-Glasses—
AND
SPECTACLE AND EYE-GLASS CASES.
OFFICE AND SALESROOM:
No. 43 MAIDEN LANE, N. Y.
FACTORIES: BROOKLYN, N. Y.

BOYCE & WAINWRIGHT,
Manufacturing Jewelers
SOLID GOLD RINGS A SPECIALTY.
Our BAND RING Specialties for PRICE,
QUALITY and FINISH are not equaled by
any in the Trade.
383 Washington St., Room 26,
E. J. BOYCE.
W. H. WAINWRIGHT. **Boston, Mass.**

M. A. LOWENSTEIN,
IMPORTER OF
DIAMONDS,
PEARLS, PRECIOUS STONES & JEWELRY,
182 BROADWAY,
Cor. John Street, **NEW YORK.**

H. M. RAYNOR
No. 25 Bond St.,
New York.
PLATINUM WIRE
AND PLATE
FOR JEWELERS.
Scrap Purchased.

H. WUNDOEHL,
GOLD & SILVER REFINER,
Assayer and Sweep Smelter,
21 JOHN ST.,
Bet. Broadway & Nassau St., **NEW YORK.**

The highest price paid for Gold, Silver and Platinum.
Fine Gold, Silver and Copper always on hand.

JACOB STRAUSS,
WATCHES & JEWELRY
AT WHOLESALE.
18 JOHN STREET, NEW YORK.
Rings and Rolled Plated Chains
A SPECIALTY.

J. B. LAURENCOT,
IMPORTER OF
WATCH GLASSES,
Optical and Fancy Goods
French Clocks, Musical Boxes, &c.
No. 33 MAIDEN LANE.
5 Rue D'Enghien, PARIS. Box 2954, P. O. NEW YORK.

W. H. LUDEMAN,
No. 75 & 77 Nassau Street,
NEW YORK.
FINE AND COMPLICATED
WATCHES
Of every description repaired and regulated.
Stem Winding and Escape Wheels
Cut and finished to order with accuracy
and promptness.

J. J. COHN,
IMPORTER OF
—WHITBY JET—
MANUFACTURER OF
Gold & Rolled Plate Jewelry,
Bracelets, Charms & Lockets a Specialty.
12 MAIDEN LANE, N. Y.
Goods Sent on Selection if Satisfactory References are
Given.

H. HOREND,
15 Maiden Lane, New York.
PUBLISHERS' AGENT
For Foreign Industrial and Art Publications concern-
ing watch and clock making and kindred arts.
English, German and French Periodicals. M.
Grossman's and other well known author's Horo-
logical works. M. Grossmann's Fine Measuring
Instruments based upon the metric system, and his
celebrated Models of Escapements.

Price Lists on Application.

L. SAUTER.
1 MAIDEN LANE,
Manufacturer of
Fine and Diamond Jewelry
AS
Rings, Studs, Buttons, Scarf Pins, Etc.
Hair Jewelry in all its branches.
Jobbing of every description promptly attended to.

JOHN D. LENNON,
142 Fulton Street,
NEW YORK,
Manufacturing Jeweler,
Masonic Pins, Rings & Charms,
School, Athletic, Fine
Presentation Medals,
—AND—
JEWELS OF EVERY DESCRIPTION
Designs furnished free upon ap-
plication.



HIBBARD G. GILL,
GOLD AND SILVER
Watch Case Manufacturer,
Dealer in Watches,
American Watch Movements Always on Hand.
618 Chestnut Street,
Fifth Floor. PHILADELPHIA.

HENRY TROEMNER,
710 Market Street,
PHILADELPHIA.
Manufacturer of Fine Gold Scales,
DIAMOND SCALES,
Bullion Balances and
Weights, in use at all the
U. S. Mints and Assay
Offices.
PRICED CATALOGUE ON APPLICATION.

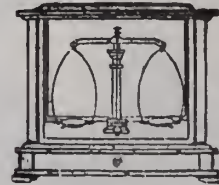

JNO. F. LUTHER,
MANUFACTURER OF
79 Nassau Street, N. Y.
Illustrated Catalogue sent on application.

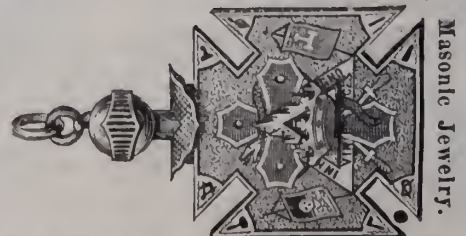

ESTABLISHED 1862.

A. LESSER & SON,
 Watchmakers' and Jewelers' Supply Depot,
 The Largest Jobbing House in Central New York!
 Elgin, Waltham, Springfield & Hampden MOVEMENTS.
GOLD AND SILVER CASES.
 A WELL-SELECTED STOCK OF FINE JEWELRY
 The Largest MATERIAL HOUSE Between New York and Chicago.
 We solicit the legitimate "Jewelers' Trade Only."
 Goods on approval require satisfactory reference
72 South Salina St., SYRACUSE, N. Y.

THEO. LESPERANCE,
 No. 1 Maiden Lane, (with Julien Gallet),
NEW YORK,
WATCHMAKER AND WHEEL CUTTER
ALSO STONING NICKEL MOVEMENTS
FOR THE TRADE.
 Altering Watches from Key to Stem-Wind
 a Specialty. Also, Importer of Diamond Hands.

C. KNAPP,
 Manufacturer of
Superior Band
and Children's
Stone & Fancy
RINGS
 And Enameled Goods,
41 Maiden Lane,
NEW YORK.

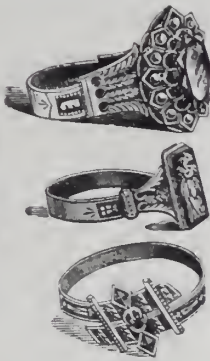

Solid Gold Rings a Specialty.
WM. H. ELY,
SOLID GOLD RINGS,
 MANUFACTURER.
 Viz., Plain, Chased, Engraved, Enameled,
 Engine Turned, Shield and Scale. All
 qualities guaranteed. Orders
 Promptly Executed.
58 Nassau Street, New York.



C. B. WILKINSON,
 Manufacturing Jeweler,
8 JOHN ST., N. Y.
 Medals, Badges and
 Masonic Jewelry
A SPECIALTY.
 Designs furnished free
 upon application.

HESS & SCHLIESSER,
 IMPORTERS OF
DIAMONDS
 AND JEWELRY.
Specialties:—Fine Novelties in French Goods,
 Gold and Blue Enameld Locketts, Charms,
 Crosses, Garnet and Silver Filigree Goods.
25 MAIDEN LANE, NEW YORK.

WM. RAWLINGS, JR.,
 Manufacturing Jeweler,
FACTORY:
913 Arch Street, Phila.
FINE GOLD RINGS A SPECIALTY.
 Goods sent on approval to any part of the
 country upon receipt of satisfactory reference.

Mansard English Geneve Louis XV.

HENRY LEFORT,
Stem-Winding Watch Crown Manufacturer,
 Crowns and Pushers in gold, all sizes, quality and color,
 made to order. Silver crowns and pushers always on hand.
60 Arlington Street,
 Corner William Street,
NEWARK, N. J.

Print Your Own Cards, &c. Press \$3.
 Large sizes for circulars, &c., \$8 to \$90.
 For pleasure, money making, young or old.
 Everything easy; printed instructions. Send
 2 stamps for Catalogue of Presses, Type,
 Cards, &c. to the factory.
Kelsey & Co., Meriden, Conn.

THE JEWELER'S BOAT.



OSGOOD FOLDING CANVAS BOAT
 Is the boat to buy; you can fold it up and carry it in your buggy,
 or on your back; it is light, safe, and strong; it rows so easily,
 you can't blister your hands, or unset it without considerable
 effort; the best portable or sportsmen's boat made in the world.
SATISFACTION GUARANTEED. Send for Illustrated Circular,
 giving full particulars and references. Manufactured by
N. A. OSGOOD, Battle Creek, Mich.
 —DEALERS IN—
 Fine Jewelry, Diamonds & Sportsmen's Goods.

P. JANDORF & BRO.,
Watches and Jewelry,
196 BROADWAY,
 Bet. John & Fulton Sts., **NEW YORK.**
We Publish No Price Lists.

WATCHMAN'S IMPROVED TIME DETECTORS,
 With Safety Lock Attachment.
U. S. Patents 1875-76-77-80-81-82.

 This instrument is supplied
 with 12 different keys for 12
 stations. It contains all
 Modern Improvements
 against the old style, and is
 the only
COMPLETE INSTRUMENT.
E. IMHAUSER,
 P. O. Box 2875.
212 Broadway, N. Y.

THE ACME OF PERFECTION.
ALWAYS have on
Sale this Celebrated
Match Case.
 It has No EQUAL on the
 Globe. No Lady's or Gentle-
 man's outfit complete with-
 out one.
Solid Nickel Silver, 50c
Bonanza Silver (equal
to Coin Silver, - - - - - 75c
 Samples or Goods sent pre-
 paid to any part of the world
 on receipt of price.
F. S. DANGERFIELD,
Sole M'fr, Auburn, N. Y., U. S. A.
 Goods sold by First-Class Dealers everywhere.

The Finest Line of High-Class English
Watches in the U. S.

GEO. E. WILKINS,
SYRACUSE, N. Y.
 Agent for the Celebrated Watches of
Chas. Frodsham & Co., London,
W. G. Schoof, London,
Karl Zimmerman, Liverpool.
Timing and Adjusting done for the Trade.
Correspondence Solicited from the Trade.

H. WASELL,
RUBBER STAMPS,
BRASS STAMPS,
Brushes, Inks, &c.
 Stencil Plates,

 Burning Brands,
SEALS & PRESSES,
No. 7 North William St.
 First house South of East River Bridge, N. Y.
FINE STEEL STAMPS A SPECIALTY.

Spencer Optical Man'fg Co.

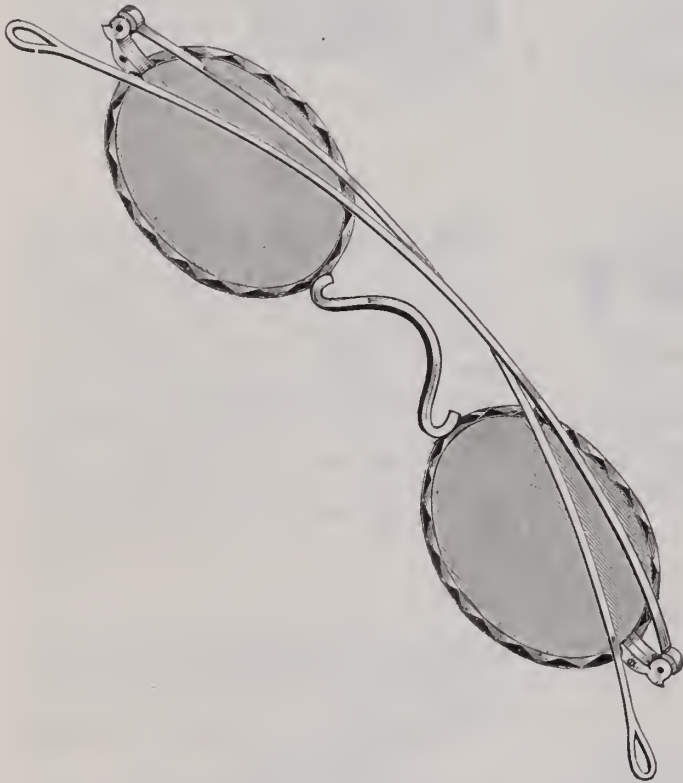
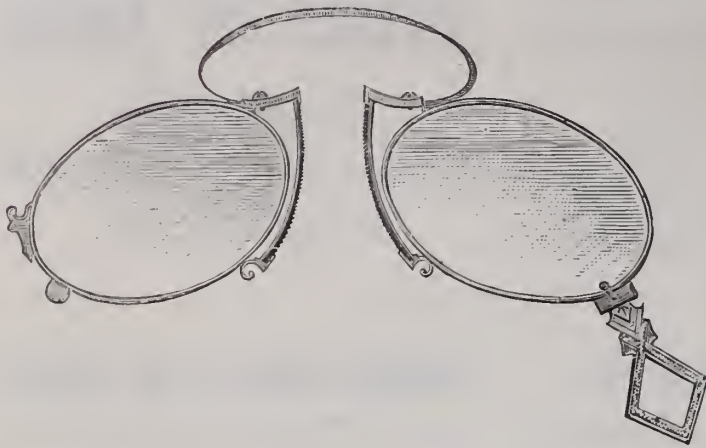

Gold Spectacles and Eye-Glasses

Are a Specialty with the SPENCER OPTICAL MAN'FG CO. They make a larger variety than any other house in the world. All of their Gold Spectacles have extra strengthening pieces at Nose-piece and End-pieces, also Gold Eye-Glasses at handles; this makes them much more durable than formerly. We have many new and original styles for the Holiday trade. All of our frames are made the Standard interchanging size. Our new Catalogue will be issued Dec. 1st, and will be sent free of charge on application and receipt of business card.

SPENCER OPTICAL M'FG CO.,

Makers of all kinds of Spectacles and Eye-Glasses,

13 MAIDEN LANE, NEW-YORK.

Established 1853.

L. H. KELLER & CO.

Successors to G. A. HUGUENIN,

IMPORTERS OF

WATCHMAKERS' and JEWELERS'

TOOLS AND MATERIALS.

GENERAL AGENTS FOR

The Philadelphia Watch Company,

— AND —

American Watch Tool Co.,

MANUFACTURERS OF

THE WHITCOMB LATHE.

SOLE AGENTS IN THE UNITED STATES FOR THE SALE OF

LUTZ'S

CELEBRATED ROLL HARDENED HAIR SPRINGS, MOEBIUS OIL

For Chronometers, Watches, Clocks, Telegraph Instruments and all other delicate machinery. Made from Pure Refined Neatsfoot Oil, and Warranted to Excel anything in the market as a Lubricator. SAMPLES GRATIS.

OUR OWN GRADUATED

AND JURGENSEN RECOILING MAINSPRINGS, pronounced by all experts Superior to all. Sold in Separate Strengths or Force.

Extra Fine Pinions cut from Solid Steel Wire. Gauged Hole Jewels of First-class Workmanship. A Full Line of Materials, for the PATEK, PHILIPPE & CO. GENEVA WATCHES, and all other Celebrated Makers.

THE BOLEY LATHES AND TOOLS,

Celebrated for their Practical, Substantial and Workmanlike Construction, Superior Design and Finish.

Our aim is to furnish nothing but First-class Serviceable Goods, especially manufactured for the Consumer, and not solely for the Market, like the cheap trash advertised in highly illustrated catalogues with which the country is flooded.

TREATISE ON MODERN HOROLOGY IN THEORY AND PRACTICE. By M. CLAUDIUS SAUNIER, Ex-Director of the School of Horology at Macon, France; Knight of the Legion of Honor, etc.; Hon. Sec. to the Paris Society of Horologists. Translated from the French by JULIEN TRIPLIN, Besançon Watch Manufacturer, and EDWARD RIGG, M. A., Assayer in the Royal Mint, London.

This Work comprises 832 large octavo pages, with 78 wood cuts and 21 colored double-page copper-plate engravings. Bound in half calf, with an appropriate and handsome ornament in gold on front cover.

Price, \$15.00.

THE WATCHMAKER'S HAND BOOK. By the same author and translators. Intended as a companion to the Treatise. Bound in cloth.

PRICE, \$4.00.

64 Nassau Street,

NEAR MAIDEN LANE,

NEW YORK.

L. H. KELLER,
EDWARD HUNZIKER, }
F. J. BOESSE.

We do not publish Price Lists.

SPECIAL NOTICES.

FOR SALE—Jeweler's safe, with drawers and iron cash box, good order. H. Carter, 176 Broadway, New York City.

WATCHMAKER of fifteen years' experience is open to an engagement. Address Watchmaker, care Jewelers' Circular.

WATCHMAKER and engraver wishes situation where a competent workman is required. Address A. G. White, care Jewelers' Circular.

WANTED—An experienced traveler, with a good material trade, to travel for a house in this city. Address B., care Jewelers' Circular.

REPAIRS for the trade undertaken and sound workman-ship guaranteed by W. F. A. Woodcock, Cumberland Md. Hall and Mosley tools, etc.

SECOND HAND watchmakers' and jewelers' tools and a small lot of materials for sale cheap for cash. E. S. Cowles, Executor, 45 Montgomery street, Jersey City, N. J.

WANTED—A young man in office, with view for salesman, prefer one who has had some experience with a manufacturing jeweler. Address Box 3554, P. O., N. Y. City.

WANTED—situation to sell goods for a good house, by a gentleman of thirteen years' experience at bench and counter. Best of reference given. Address Lock Box 113, Fulton, N. Y.

WANTED—Position with a number one jewelry house to sell goods to an established trade in Iowa, Wisconsin and Minnesota. Address Traveler, care *Jewelers' Journal*, Chicago.

WANTED—A situation in a first-class jewelry establishment as an apprentice, with one year's experience. Can furnish good references. Address C. A. Keene, Box 15, Boudolnham, Maine.

AMERICAN HOROLOGICAL JOURNAL wanted.—Nos. 2, 3, 4, 5, 6, 7, 8, 9 and 10. Vol. 2. No. 1, Vol. 3. Nos. 3, 4, 5, 6, 7, 8, 9, 10, 11 and 12. Vol. 5. Address, stating price, J. Walker, Box 141, N. Y. P. O.

WANTED—A first-class workman of temperate habits to do clock work and jewelry repairing. A single man, with best of references, is what I want at once. U. W. Frink, 101 Main street, Brattleboro, Vt.

MOSELEY & CO., Elgin, Ill., manufacturers of the "Moseley" Lathe, with full line of fixtures and attachments. Designed especially for the watchmaker and repairer. Combining accuracy, durability, convenience and style.

FOR SALE—In a prospering town of 4,000 inhabitants in north-western Iowa, stock and fixtures of jewelry store, invoice \$2,000. Can be reduced. Desires to sell inside 60 days. Address Jeweler, care of 743 Clay street, Dubuque, Iowa.

WANTED—A situation as an apprentice to a competent watchmaker, city or country. Have had 2 years' experience in repairing clocks and jewelry. Satisfactory references given. Address Courtney Adkin, Mt. Sterling, Brown Co., Ills.

FOR SALE—Jewelry business in flourishing town of 5,000 inhabitants. Good fixtures, with any quantity of stock wanted, good location and an excellent opening for a young man. Only one competitor. Address W. H. F., care Jewelers' Circular.

WANTED—situation to work under instructions for one year, in New York, with some house where I can get plenty of fine work to work at. Have worked four years at the trade and can furnish good references. Address T., care Jewelers' Circular.

SITUATION WANTED—As traveler, by a person well acquainted in the trade in the United States and Canada. Can handle watches, diamonds, jewelry, opticians' goods, jewelers' and watchmakers' tools and findings. Address Hamilton, care Jewelers' Circular.

FOR \$5.00 I will change to a stem wind and set, any American 18 size movement, except (Springfield, Mass.) This is a new patent device and is in no way inferior to any stem wind ever made. Send for circular to Reeves & Co., room 8, No. 713 Sanson street, Phila.

YOUNG MAN who has learned the watchmaker's trade desires a situation in a first-class jewelry store where he may have an opportunity to improve under a competent workman. Best of reference given if required. Address Sidney Smith, Jr., Lafayette, Sussex Co., New Jersey

WATCHMAKER of 14 years' experience in wholesale and retail stores, desires a situation, is sober and steady and fully competent to take charge of work in any store, has a fine set of tools, a quick and rapid workman, and a good salesman. Large city preferred. Ed. L. White, Wadsworth, Ohio.

GEORGE E. WILKINS, manufacturer and importer of cutters for watchmakers' use, stem-winding cutters of all the different forms, rounding up cutters of the finest quality, also ratchet cutters. A large stock of second hand and new marine chronometers. No. 21 South Salina street, Syracuse, N. Y.

FOR SALE—A snug jewelry business in north-western Iowa, in a growing city. Stock and fixtures will invoice about \$3,000. Not a dollar's worth of old stock. Modern show cases and fixtures, and cheap rent. Repairing will run about \$100 per month. Bad health the cause of selling. Address "Business," care this office.

FACING STONES.—Every watchmaker in the United States and foreign countries sending the piece will receive a finely finished stone to produce that fine flat polish upon jewel settings and scape wheels in a few seconds. Stone alone, \$1.50. In case, \$2. Full instructions given with each one. H. B. Weiland, Watchmaker, Lancaster, Pa.

SPECIAL NOTICE.—I am closing up business here and will leave this place without a watchmaker or stock of goods. Population of county 12,000. No other store in county. Annual sales about \$8,000, good run of work. Business established 43½ years. A good place for a man with small capital. All questions promptly answered. Address S. O. Ebersole, Minneapolis, Kans.

WANTED—Every Jeweler to know that the **Pikes Peak Mineral Clock** is composed of from fifty to one hundred choice specimens of Gold and Silver Ores, Petrified Woods, Topazes, Agates, etc. Delivered to any express office in the U. S. for \$7.25 each, cash. Send all orders to C. W. Little, wholesale manufacturing and importing jeweler, 324 & 326 15th street, Denver, Col.

FOR SALE AT A BARGAIN—A clean stock of jewelry, watches, clocks, etc. Fixtures and all involving about \$7,000. Best location in the city of Denver, well established, doing a good paying business, and largest run of fine watch repairing in the city. For sale only for cash. Satisfactory reasons for selling. Parties meaning business address Max. Kuncer, 267 16th street, Denver, Colorado.

LATHE FOR SALE.—A combination lathe, made by J. Stark, consisting of chuck, pivoting and universal heads, slide and jewelry rests, grinding, open and screw tail stocks, pivot polisher, file rest, improved staking tool, back counter, wheel and treadle in black walnut, bench, 26 wire chucks, 4 wheel or step chucks, 1 taper and lap and 1 dog chuck. Address E. P., Lock Box Q, So. Waltham.

FOR SALE—An established jewelry store in a southern city of 8,000 inhabitants, with large manufacturing interests. Stock of goods new and well bought for cash, together with safe, show cases, counter, regulator, etc., will invoice about \$6,000. Arrangements can be made to buy fixtures and part of stock for \$2,000, owner being engaged in the wholesale business in Nashville, Tenn. Address M. T. Graham, Nashville, Tenn.

WANTED—By a competent watchmaker, engraver and salesman (American), a situation in a western city, Chicago preferred, no objection to New York. Highest references furnished. Worked at the bench 17 years. Thoroughly understands the business. Present salary eighteen hundred dollars per annum. Will purchase stock, fixtures and good will from one wishing to retire from business. Address K. K., care Jewelers' Circular.

BUYERS' DIRECTORY.

NEW YORK.

Assayers and Sweep Smelters.

Wundoehl, H.—Gold and Silver Refiner, Assayer and Sweep Smelter. 21 John Street, N. Y.

Badges and Medals.

Stockwell & Newman—19 John Street. Manufacturers of Badges, Medals and Presentation Pieces in Gold and Silver. Also Jewelry and Mounters of Diamonds. Designs supplied.

Wilkinson, C. B.—Manufacturing Jeweler, 8 John Street, N. Y. Medals, Badges and Masonic Jewelry a Specialty. Designs furnished free upon application.

Band Rings.

Knapp, Charles, 41 Maiden Lane, N. Y. Specialty: Superior Band Rings, also Ring Shanks & Heads for Seal and Diamond Rings.

Bangles and Bangle Rings.

Harrison, Henry—Manufacturer of Gold Bangles and Bangle Rings. Also dealer in Watches and Jewelry. 66 Nassau Street, N. Y.

Black Onyx Jewelry.

Cox & Sedgwick—Manufacturers of Black Onyx Jewelry, No. 26 John St. New York.

Woglom & Miller—Manufacturers of (exclusively) Black Onyx Jewelry, 32 & 34 John St., N. Y.

Blue Enameled Locketts.

Bissinger, Philip & Co.—Importers of Diamonds, Pearls and Precious Stones. Agent for the Bohemian Garnet Goods. Blue Enameled Locketts. 22 John St., N. Y.

Hess & Schliesser—Importers of Diamonds, Fine Jewelry and Novelties in French Goods. Specialties: Gold and Blue Enameled Locketts, Charms and Crosses. 25 Maiden Lane.

Bohemian Garnet Jewelry.

Bissinger, Philip & Co.—Importers of Diamonds, Pearls and Precious Stones. Sole Agent for the Bohemian Garnet Jewelry. Blue Enameled Locketts. 22 John St.

Boxes, Wood Mailing and Nested.

Maine Manufacturing Co.—Successor to Swift Manufacturing Co., Makers of Wood Mailing and Nested Boxes for mailing and express purposes. No. 12 Courtland street, N. Y.

Wiesbauer, J.—Manufacturer of the Sliding Cover Wood Mailing Boxes. All Sizes Made to Order. Buffalo, N. Y.

Castings.

C. H. Leonhardt—Manufacturer of Fine Jewelry and Charms. All kinds of Moulding and Casting in Gold and Silver done for the Trade; largest assortment of Models. 65 and 67 Nassau Street.

Clock Companies.

Ansonia Clock Co.—Manufacturers of every description of Clocks. 11 to 21 Cliff street, New York.

Kroeber, F.—Manufacturer and Dealer in American and French Clocks, No. 8 Cortlandt Street.

New Haven Clock Co.—62 Reade Street, N. Y.

Seth Thomas Clock Co.—20 Murray Street, N. Y.

Waterbury Clock Co.—M. Bailey, Treasurer, Manuf. and Jobbers, No. 4 Cortland St., N. Y., and No. 197 State Street, Chicago.

Welch, E. N. Mfg Co.—6 Warren Street, New York. E. C. Hine, Treasurer and General Manager. 170 State Street, Chicago, F. E. Morse, Agent.

Wm. L. Gilbert Clock Co.—No. 6 Murray Street, Manufacturers of Clocks. Factories, Winsted, Conn.

Corals and Coral Jewelry.

Cuppia, L. A.—Importer of Coral and Silver Filigree Jewelry, 19 Union Square, N. Y.

Cameo Cutters, Etc.

Peiter, Theodore—Cameo and Intaglio Engraver. Patentee of the Cameo-Intaglio. No. 2 Bond Street, near Broadway, Room 4 New York.

Charms & Gold Watch Keys.

Rupp & Held—Manufacturing Jewelers, Charms and Gold Watch Keys, with French and English Ratchets, a specialty. 15 John St., N. Y.

Crucibles.

Berge, J. & H.—Established 1850, Manufacturers and Importers of Sand Crucibles, Covers, Chemical Porcelain, Glassware, and Jewelers' and Assayers' Supplies, 95 John Street, N. Y.

Berge, J. & Son—Importers of Sand Crucibles and Covers, Jewelers' Tools and Materials, Manufacturers of Berge's Improved Assay and Enamel Furnace, Assay and Enamel Muffles, &c. 112 William St., N. Y.

Cutlery.

Harrison Bros. & Howson—Manufacturers of Fine Ivory and Pearl Table and Pocket Cutlery, Carvers in Cases; Nutpicks, Nutcracks and goods suitable for the jewelry trade. 126 Chambers Street. W. C. Burkinshaw, Sole Agent.

Diamond Brokers.

Anderson, Otis—Diamond Merchant and Broker, always ready to pay cash for bargains in Diamonds and Precious Stones, 4 & 6 John Street, N. Y.

Bernhardt, Richard—Diamond Broker and Importer, 65 Nassau Street (Room 6), N. Y. Paris, 20, rue des Petites-Écuries.

Friend S. & Son—Brokers and dealers in Diamonds 33 John Street, cor. Nassau St. New York.

Herbert, R. J.—Diamond Broker and Dealer. 26 Maiden Lane.

Diamond Importers.

Bissinger, Philip & Co.—Importers of Diamonds, Pearls and Precious Stones. Agent for the Bohemian Garnet Goods. Blue Enameled Locketts. No. 22 John St., N. Y.

Bruhl, D. & M.—Established 1848. Importers of Diamonds and Precious Stones. 14 Maiden Lane, New York. Branch office, Paris. Also 111 Broad Street, Providence, R. I.

Brunswick, S. & Co.—Importers of Diamonds, 17 Maiden Lane, New York. Paris, Rue Lafayette. Amsterdam, Damsstraat.

Citroen, L. B. & Co.—Diamonds. 21 John St., N. Y. Cutting Works, 57 & 61 Rapenburgerstraat, Amsterdam. House in Paris, 44 Rue Laffitte.

Engelmann, M. & Co.—Importers of Diamonds, Pearls and Precious Stones. Specialties in Fine Colored Stones. 192 Broadway and 1 and 3 John Street, N. Y. Paris, 1 Boulevard St. Denis.

Faulkenau, Oppenheimer & Co.—Manufacturers. Diamonds and Diamond Jewelry. 40 Maiden Lane, N. Y.

Fera, Henry—Importer of Diamonds, and Manufacturer of Fine Diamond Jewelry. 4 & 6 John Street, New York. Amsterdam, Holland, 23 Loojersgracht.

Fox, M. & Co.—Importers of Diamonds, Rubies, Sapphires and Fancy Gems. No. 1 Maiden Lane, New York.

Hedges, Wm. S. & Co.—Importers of Diamonds, No. 170 Broadway, corner Maiden Lane.

Kuhn, Doerflinger, & Co.—Manufacturing Jewelers and Importers of Diamonds, 18 John Street, New York.

Lowenstein, M. A.—Importer of Diamonds, Pearls, Precious Stones and Jewelry. 182 Broadway, N. Y.

Neresheimer, E. Aug. & Co.—Importer of Diamonds. No. 21 Maiden Lane, New York

Randel, Baremore & Billings—Importers of Diamonds, corner Maiden Lane and Nassau St.

Saunders & Ives—Importers of Diamonds and other Precious Stones. No. 26 Maiden Lane.

Smith, Alfred H. & Co.—Importers of Diamonds, No. 182 Broadway.

Taylor & Brother—Importers of Diamonds and Diamond Jewelry. 676 Broadway.

Wickham, D. H. & Co.—Importer of Diamonds. No. 31 Holborn Viaduct, London, 24 Maiden Lane, New York.

Wolff, G. A.—Importer of Diamonds, Rubies, Sapphires, Pearls, and other Precious Stones, 35 Maiden Lane, New York. 12 Rue de Chateaudun, Paris.

Diamond Jewelry.

Bernhard, A. & Co.—Importers of Diamonds and Manufacturers of First-Class Diamond Jewelry. Diamond Settings for Manufacturing Jewelers. Design Sheets for the Trade free of charge. 2 Maiden Lane, New York.

Bornemann, Louis—Importer of Diamonds and Manufacturer of Rich Diamond Jewelry, 19 John Street, New York.

Chalumeau, D.—Diamond Jeweler and Manufacturer of Mountings. Novelties and Artistic Jewelry. No. 3 Maiden Lane, New York.

Hartje, G. & F.—Manufacturers of Diamond and Fine Jewelry, 860 Broadway, cor. 17th street, N. Y.

Heller & Bardel—Manufacturers of Diamond and Pearl Jewelry, and Dealers in Diamonds, Pearls, &c. 13 John Street.

Jeanne Brothers—Manufacturers of Diamond Mountings & Rich Jewelry. 1 Maiden Lane.

Lacroix & Verpillier—Manufacturers of Fine Gold Jewelry. Diamonds a specialty. 173 Broadway, N. Y.

Schilling & Nissen—Dealers in Diamonds and Diamond Jewelry. No. 51 Nassau Street, New York, near Maiden Lane.

Voelker, C. T.—Manufacturer of 18-k. Diamond Mountings, Diamond Jewelry and Roller Chain Bracelets. 189 Broadway, New York.

Waterman & Lehmann—Manufacturing Jewelers and Dealers in Diamonds. Diamond Work, and Fine fancy Rings a specialty, any piece of single work made to order. 37 Maiden Lane, N. Y.

Diamond and Pearl Setter, &c.

Archibald, Wm.—Diamond Setter for the Trade. Cameos, Pearls, Turquoises, Garnets, Amethysts, Doublets, Foil Backs, white and colored, Imitation Stones. 73 Nassau Street, N. Y., room 7.

Diamond Cutters.

Hermann, I.—Importer of Diamonds and Precious Stones. Diamond Cutter and Polisher. Manufacturer of Diamond Jewelry. 19 East 15th Street, New York.

Levy, Herman—Importer, Cutter and Polisher of Diamonds. 105 Fulton Street, New York.

Dials, &c.

Farnsworth, C. E. & Co.—Successors to J. T. Gold, Enamel Watch Dial Makers. 81 Nassau Street, N. Y.

New York Dial Co.—Manufacturers of Fine Watch Dials. Henry Abbott, Agent, No. 7 Maiden Lane, N. Y.

Enameled Clock Dials and Figures.

Caesar Bros.—Manufacturers of Enameled Clock Dials, also letters and numbers for signs. 230 and 232 East 25th Street, New York.

Enamelers, Etc.

Nutt, J. D.—Enameler on Gold, Silver, and Copper. Linen finished Buttons and Studs. Enameling in colors. 32 and 34 John Street, New York.

Orr, J. C.—Enameler on Fine Jewelry. Enameled in Colors. Linen Finished Buttons and Studs. Band Bracelets. No. 75 Nassau Street, N. Y.

Electroplaters, &c.

Jeandheur, F. & Son—Gold and Silver Electro Platers & Fire Gilders, coloring Etruscan and Gold Jewelry a specialty. 125 Fulton St.

Engravers—Stone Seal, Etc.

Fackner, Edward—Carver, Engraver and Chaser on Jewelry and Pencil Cases, lettering, &c., 19 John Street.

Holland & Gosling—Stone Seal Engravers. Precious Stones inlaid and encrusted with Diamonds. No. 176 Broadway, New York, (fifth floor per elevator). Cameos cut and repaired.

Knapp, Chas.—Engraver, Die Sinker & Stamper for Jewelry purposes. Ring Shanks & superior Band rings, 41 Maiden Lane, N. Y.

Meister, H.—Engraver and Chaser on Fine Jewelry, Badges, Monograms, Coats of Arms, etc.; also Enameling, Coloring and Polishing. No. 59 Nassau Street, New York.

Park, Wm.—The Stone Seal Engraver. Arms, Crests, Monograms, etc., engraved on precious stones, 26 John Street, New York.

Weston, James F.—Stone Seal Engraver and in-cruster of Precious Stones. Coats of Arms, Masonic, Odd Fellows, and other devices engraved. 32 John Street.

Fancy Goods, Clocks, Bronzes, Etc.

Le Boutillier & Co.—Importers of Fancy Goods, Clocks, Bronzes, &c., 3 Union Square.

Taylor & Bro.—Importers of French Clocks, Bronzes, etc. 676 Broadway, N. Y.

Gold and Silver Cane Heads.

Simons Bro. & Co.—Manufacturers of Gold Headed Canes. 611 and 613 Sansom street, Philadelphia.

Gold and Silver Plating, Etc.

Bantle, A.—Gold and Silver Plating and Fire Gilding. 79 Nassau Street, Room 17, N. Y. Watches and Jewelry a Specialty.

Gold Band Bracelets.

Harrison, Henry—Manufacturer of Gold Band and Buckle Bracelets. 66 Nassau Street, N. Y.

Gold Chains, Etc.

Beck, J. & Son, Manufacturers of Fine Gold Chains and Chain Bracelets, 10 Liberty Place, near Maiden Lane, N. Y.

Carter, Sloan & Co.—Manufacturers of Fine Gold Chain, Whiting Building, 4th St. and Broadway.

Dorrance, Edge & Co.—Manufacturers of the Celebrated Woven Fabric Gold Chain, No. 15 John Street.

Kaufmann Bros.—Manufacturers of Gold Chains, and Chain Bracelets, 26 John Street; Factory, 331 and 333 Bowery, N. Y.

Kohn, Alois & Co.—Manufacturers of Gold Chains. 9 Maiden Lane, N. Y.

Nordt, Charles—Successor to Nordt & Schlag, manufacturer of Gold Chains and Chain Bracelets. Jobbing and Refilling Old Chains promptly attended to. No. 17 Maiden Lane, N. Y.

Saxton, Smith & Co.—Manufacturers of Fine Gold Chain, No. 14 John Street, N. Y.

Schlag, Chas.—Late Nordt & Schlag, Manufacturer of Gold Chains, Chain Bracelets, and Fine Jewelry, 177 Broadway, N. Y.

Smith, W. & Co.—Manufacturers of Gold and Silver Chains, Jewelry, etc. No. 25 Maiden Lane, N. Y.

Cold Goods.

Hale, S. W. & Co.—Manufacturers of Jewelry of Artistic Design. No. 694 Broadway, N. Y.

Gold Pens, Etc.

Aikin, Lambert & Co.—Manufacturers of Choice Gold Pens, Cases, Holders, Toothpicks, etc., 23 Maiden Lane, N. Y.

Faber, Eberhard—Manufacturer of 16-karat Gold Pens and Pencil Cases, Nos. 718 and 720 Broadway, N. Y.

Johnson, E. S. & Co.—Manufacturers of Gold Pens, Pen Holders and Pencils. Cor. Maiden Lane and Nassau Street, New York.

Smith, H. M. & Co.—Manufacturers of Gold Pens and Holders, Tooth Picks, Pencils, etc. Sole Manufacturers of Sprague's Patent Gold Fountain Pen. Importers of Nickel and Silver Watches. 173 Broadway, New York.

Gold Rings.

Barnet Bros. & Fowell—Manufacturers of Solid Gold Rings, 15 John Street, New York. Factory, Newark, N. J.

Bowden, J. B. & Co.—Manufacturing Jeweler.—Solid Gold Rings a specialty, 1 Maiden Lane.

Ely, W. H.—Manufacturer of Solid Gold Rings of every description. No. 58 Nassau Street.

Kroll, H.—Manufacturing Jeweler. 78 Nassau Street, New York. Specialty: Solid Gold Stone Rings. All kinds of Fine Jewelry made to order, also Repairing for the Trade.

Durlach, Henry—Manufacturing Jeweler. No. 75 & 77 Nassau St. Seal, Cam.o, Amethyst and Garnet Rings a special y.

Peckham, Wm. H.—Manufacturers of Solid Gold Seamless Rings, and Fancy Embossed Rings, Patent Spectacles, Jewelry, etc. No. 4 Liberty Place N. Y.

Radler, K.—Manufacturing Jeweler. Gold Rings and Locketts a specialty. No. 39 Maiden Lane, New York.

Sauter, L.—No. 1 Maiden Lane, New York, Manufacturer of Stone Rings of every description, as Diamond, Cameo, Onyx Turquoise, etc., Scarf Pins, Scarf Rings, Studs and Buttons.

Schnurbusch, H.—Manufacturer of Solid Gold Rings. Specialty: Seal, Cameo, Pearl, Turquoise, Amethyst, Onyx and Garnet Rings. No. 3 Maiden Lane, N. Y.

Shafer & Douglass—Manufacturers of all kinds of Seal, Stone, Turquoise, and fancy rings. No. 7 Maiden Lane, N. Y.

Sinnock & Sherrill—Manufacturers of Stone Rings. No. 3 Maiden Lane, N. Y.

Hair Jewelry.

Bernhard, A. & Co.—Manufacturers of Fine Hair Jewelry. Pattern Book of 2,700 designs free of charge to the First-class Trade. 2 Maiden Lane, New York.

Moutoux, Wm. E. & Co.—Manufacturers of Fine Hair Mountings in Gold. Grand catalogues for the trade. 81 Nassau St., Rooms 1 and 2. Finest work and lowest prices

Sauter, L.—Manufacturer of Fine Gold and Hair Jewelry and Device Work. Pattern Book sent on application. No. 1 Maiden Lane, N. Y.

Schwencke O.—Manufacturer of Fine Hair Jewelry Orders from the country promptly attended to. No. 43 Maiden Lane.

Jewelry Cases, Fancy Boxes, Etc.

American Morocco Case Co.—7 and 9 Bond St., N. Y., make a specialty of Rich Jewelry and Silverware Cases for the fine Retail Trade. Also Improved Trays for Watches, Rings, etc.

Braun, Chr. E.—Manufacturer of Fine Jewelry Boxes and Trays for Show Cases and Trunks. No. 62 Chatham Street, New York. Trays for Show Cases and Trunks a Specialty.

Bricka, C. A. & Co.—Manufacturers of Morocco Cases for Cutlery, Silverware, Jewelry, etc. Sample Cards and Rolls. Cases in Rosewood, Black Walnut, etc. 52 Nassau Street, New York.

Dennison Mfg Co.—Manufacturers of Morocco, Plush and Velvet Jewelry and Silverware cases. New York, Boston, Philadelphia, Chicago, Cincinnati and St. Louis.

- Ettlinger, L. & Sons.**—Manufacturers of Fine Cases for Jewelry, Watches and Silverware. Trays for Travelers and Show Cases. Cases to Order a Specialty. No. 80 Nassau St., N. Y.
- Haensler, Chas. C.**—Manufacturer of Fine Morocco Cases for Jewelry and Silverware. Toilet Boxes, etc. Trays for Show Cases and Windows. 14 John Street, New York.
- Jackson, S. C.**, 180 Broadway, N. Y., Manufacturer of Fine Cases for Jewelry, Silverware, &c.
- Kohn, Solomon & Co.**—Manufacturers of Fine Morocco Cases for Jewelry, Watches, etc. 15 John Street, New York.
- Kron & Krumpel**—Manufacturers of Fine Morocco and Plush Cases for Watches, Jewelry, Silverware, etc. 169 William Street, Room 11, New York. Trays for Jewelers and Sample Trays for Travelers a specialty.
- Lauten, Edw. A. & Co.**—No. 4 Great Jones St., Manufacturers of fine Velvet, Brocade, Plush and Morocco Boxes, for Jewelry, Watches and Silverware, Patent Ring, Ear Ring and Gents' Scarf Pin Trays.
- Loehr & Koerner**—Manufacturers of Morocco, Velvet, Satin, Jewelry, Watches and Silverware Cases, Jewel, Work Boxes, etc., Fancy Trays and Store Fittings to order. 96 Liberty St.
- New York Morocco Case Co.**—Cases for Jewelry, Watches, Silverware. Boxes and Trays for Jewelers' Travelers. Show Cases and Window Fittings. No. 69 Nassau Street, New York.
- Schien, Charles E.**—Manufacturer of Cases for Jewelry and Silverware, No. 85 Nassau St., N. Y. Show Case Trays, etc., at short notice.
- Schwarz, N.**—Manufacturer of fine Cases for Jewelry and Silverware, 866 Broadway, near 17th street, N. Y.
- Steinle, E.**—Manufacturer of Cases for Jewelry of all kinds. Also Cases for Mathematical and Surgical Instruments and for Trays for Travelers' Trunks, etc. 66 Nassau Street, N. Y.
- The Novelty Case Co.**—Manufacturers of Jewelry and Silverware Cases of all description. Fancy boxes and specialties in great variety. No. 114 East 14th Street.
- Welch & Miller**—Manufacturers of Morocco, Velvet, and Satin Jewelry Cases, Trays, &c., Telescope Sample Cases with flexible Trays. Complete stock on hand. 169 Broadway
- Wiggers & Froelick**—No. 60 Nassau street—Manufacturers of Cases for Jewelry, &c., of every description. Trays for Show-cases, Stands for Show-windows, etc.
- Jewelers' Findings.**
- Dennison Mfg Co.**—Paper Jewelry Boxes, cards, tags, pink and white cotton, etc. etc. New York, Boston, Chicago, Cincinnati, Philadelphia, St. Louis.
- Ettlinger, L. & Sons.**—Manufacturers of Jewelers' Paper Boxes and Findings. Morocco Paper, Satin or Plush Lined Wooden Corner Stops Jewelry and Silverware Boxes. 80 Nassau Street, New York.
- Lehmann, Ludwig.**—Manufacturer of Jewelers' Findings. Tags, Pink and White Cotton, and Tissue Paper. Specialty, Fine Paper Boxes for Jewelers and Silversmiths. 122 Fulton Street.
- Valfer, S. & Co.**—Manufacturers and Dealers in Jewelers' Boxes, Tags, Cards, Paper and Findings. Office and Salesroom, 66 Nassau street, New York.
- Jewelry Manufacturers.**
- Aikin, Lambert & Co.**—Manufacturers General stock of Reliable Jewelry, 23 Maiden Lane.
- Alford, C. G. & Co.**—Manufacturers. General line fine and Reliable Goods. Specialties in Onyx Goods and Chain. 200 Broadway, New York.
- Alling & Co.**—Manufacturing Jewelers, 170 Broadway.
- Baldwin, Sexton & Peterson**—Makers of Fine Jewelry and Importers of Diamonds, etc., corner Broadway and Fourth Street.
- Ball, W. H.**—Manufacturer of Gold Jewelry. Bracelets and Bangles of all kinds a specialty. 9 John Street, N. Y.
- Barthman, Straat & Co.**—Manufacturers of Fine Jewelry. Roman Goods, Rings, Diamonds. No. 43 Maiden Lane.
- Bernhard, A. & Co.**—Manufacturers of General Fine Work. Specialties: Diamond Jewelry, Diamond Settings, Hair Jewelry, Fancy Rings, Rose Diamond Monogram and Onyx Work. 2 Maiden Lane, New York.
- Brown, Thos. G. & Sons**—Man'rs of Rich Jewelry Necklaces, Locketts, Bracelets, Sleeve Buttons, etc., 5 Bond Street, N. Y.
- Bryant & Bentley**—Manufacturing Jewelers. Rings a specialty. 12 Maiden Lane
- Carter, Sloan & Co.**—Manufacturing Jewelers Whiting Building, 4th St. and Broadway.
- Champenois & Co.**—No. 5 Maiden Lane, manufacturers of Engraved and Enameled Gold goods, in Sets, Ear Knobs, Bracelets, Studs, Lace and Shawl Pins, Jet cluster and Onyx goods, also "Best Lever" Sleeve Buttons.
- Chatellier, Joseph F.**—Manufacturing Jeweler, No. 694 Broadway, N. Y.
- Churchill, Lewis & Co.**—Manufacturers of Fine Jewelry. 692 Broadway, cor. Fourth St., N. Y.
- Cook, Groeschel & Co.**—Manufacturers of Fine Jewelry and Locketts, 191 Broadway (over Mercantile Bank.) N. Y.
- Cottle S. Co.**—Manufacturers of Fine Jewelry. Waltham Building, 5 Bond Street, N. Y.
- Cox & Sedgwick**—Manufacturers of fine Onyx and Colored Jewelry. 26 John St., New York
- Day & Clark**—Manufacturers of Fine Jewelry, Lace Pins, Ear Rings, Studs, Locketts, &c., 192 Broadway, cor. John St., New York.
- Geoffroy, Arthur R. & Co.**—Manufacturing Jewelers. Novelties in Diamond Goods. No. 23 Maiden Lane, N. Y.
- Goddard, John M.**—Manufacturing Jeweler,—Seal Rings and Fine Locketts a specialty, No. 3 Maiden Lane, N. Y.
- Goldsmith & Cohen**—Manufacturing Jewelers, 3 Maiden Lane, New York.
- Greason J. R. & Co.**—Successors to Arthur, Runrill & Co., 182 Broadway. Manufacturers of Fine Jewelry and Gold Chains, also Diamond Mountings.
- Greene Wm. C. & Co.**—Goldsmiths; Manufacturers of Rich Sets in Taper Wire Coral. Office, 192 Broadway.
- Hale, S. W. & Co.**—Manufacturers Rich Jewelry, Whiting Building, Broadway and 4th Street.
- Hartmann, P.**—Manufacturer & Importer of Fine Gold, Diamond, and Filigree Silver Jewelry, No. 36 Maiden Lane. P. O. Box 2,454.
- Haskell, H. C.**—Manufacturing Jeweler. Seal Rings a specialty. Special attention to Jobbing of every description. 12 John street.
- Hedges, A. J. & Co.**—Manufacturing Jewelers, 6 Maiden Lane.
- Henderson & Winter**—Jewelers, No. 15 Maiden Lane, New York. Specialties—Stone, Cameo, Onyx, Amethyst, Topaz, Pearl and Turquoise Rings.
- Hunt & Owen.**—Manufacturing Jewelers. Office 3 Maiden Lane.
- Kennedy, Frank S.**—Manufacturer and Wholesale Dealer in Jewelry and Gold and Silver Thimbles. No. 13 Maiden Lane, New York.
- Kremetz & Co.**—Manufacturing Jewelers, No. 192 Broadway. N. Y.
- Kuhn, Doerflinger & Co.**—Manufacturers of Enameled and Roman Band Bracelets, also Fine Locketts Pendants and Lace Pins. 18 John street.
- Lennon, John D.**—Manufacturing Jeweler, 142 Fulton Street. Stone Locketts and Rings; also Badges and Emblems of all kinds.
- Miller Bros.**—Manufacturers of Fine Jewelry, Locketts, Sleeve Buttons, Studs, &c., 7 Maiden Lane, N. Y.
- Moore & Horton.**—11 Maiden Lane, Manufacturing Jewelers, Rings, Studs, Collars and Sleeve Buttons, Pins, Ear-rings, &c.
- Muhr's, H., Sons.**—Manufacturing Jewelers. Solid Gold and Filled Rings a specialty. Also Manufacturers of the celebrated Crown Filled Watch Case. 1½ Maiden Lane, N. Y.
- Owen, G. & S. & Co.**—Manufacturing Jewelers. Office, No. 3 Maiden Lane.
- Richardson, Enos & Co.**—Manufacturers of Fine Gold Jewelry, Gold Chains, Locketts, Crosses and Necklaces. Colored and Etruscan Work. No. 23 Maiden Lane, New York.
- Richardson, J. W. & Co.**—Manufacturers of Jewelry. Masonic and other Emblems. 196 Broadway, N. Y. Manufacturing, Providence, R. I.
- Riley, J. A. & Co.**—Manufacturing Jewelers. Etruscan Gold and Roman Bracelets, Lace Pins, Ear Rings, Scarf Pins, Brooch Pins, etc. Nos. 7 and 9 Bond Street, N. Y.
- Ripley, Howland & Co.**—Manufacturers of Fine Jewelry and Platinum Tipped Diamond Settings. No. 17 Maiden Lane, N. Y.
- Sauter, L.**—Manufacturer of Fine Jewelry, Solid Stone Rings and Studs a specialty. Jobbing for the trade. 1 Maiden Lane, New York.
- Sexton & Cole**—Manufacturing Jewelers, Colored Gold and Onyx Goods a specialty. No. 30 Maiden Lane.
- Shafer & Douglas,** Manufacturing Jewelers—Roman Goods, Lace Pins, Cameo Sets, etc., Stone Rings, etc. No. 7 Maiden Lane, N. Y.
- Sheafer, W. H. & Co.**—Manufacturing Jewelers, Specialty Bangles and Bracelets, 15 John St., N. Y.
- Steele, J. W.**—Successor to Brainerd, Steele & Co., Manufacturer of Fine Jewelry and Brainerd's Patent Locketts. No. 9 Maiden Lane, N. Y.
- Stites, D. H. & Son**—Manufacturers of Fine Jewelry, Rolled Plated Goods and Chains, Parisian Diamond Rings, Studs and Earrings a specialty. 41 Maiden Lane, N. Y.
- Stites' Sons, E.**—Manufacturers of Fine Jewelry. No. 14 John Street, N. Y.
- Street, Geo. O. & Sons.**—Established 1837. Makers of Fine Jewelry, strictly first-class goods of our own make. No. 15 John Street, New York.
- Terhune, Charles F.**—Manufacturing Jeweler, 194 Broadway, N. Y.
- Thoma, Ernest**—Manufacturer of Fine Jewelry, Sleeve Buttons, Rings, Ear-rings, &c. No. 173 Broadway, N. Y. Factory, Hackensack, N. I.
- Unger Bros.**—Makers of Fine Gold Jewelry, consisting of Lace Pins, Earrings, Collar Buttons, Band Rings White Enameled Studs, etc. Also Patent Onyx Bracelets, 9 Maiden Lane, N. Y.
- Ward, Thos. M.**—Manufacturer of Fine Jewelry, Diamond Mountings a specialty. No. 25 John Street, N. Y.
- Wheeler, Parsons & Hays.**—Manufacturers of Fine Jewelry, Watch Cases, Gold Chains, &c. and Dealer in American and Swiss Watches, No. 2 Maiden Lane, N. Y.
- Wiendhold, Joseph**—Manufacturer of Fine Jewelry and Diamond Setter. 24 John St.
- Woglom & Miller**—Manufacturers of Black Onyx Goods exclusively. 32 & 34 John Street, N. Y.
- Jewelry—Rolled Plate.**
- Frick, John & Co.**—Fine Rolled Plate Jewelry of all kinds. Repairing of every description. 21 and 23 Maiden Lane, N. Y.
- Mauran, J. T.**—Manufacturer of Fine Rolled Plate Jewelry, No. 15 Maiden Lane, N. Y.
- Richards, E. Ira & Co.**—Manufacturers of Fine Rolled Plate Jewelry, No. 200 Broadway, N. Y.
- Weil, Leopold & Co.**—Manufacturers of Rolled Plate Jewelry of every description, 16 Maiden Lane, N. Y.
- Jewelers' Tools, etc.**
- Fisher, James J.**—Dealer in Watchmakers' and Jewelers' Materials, Files, Tools, Silk Guards, Spectacles, etc., 697 Broadway, N. Y.
- Frasse & Co.**—Importers of Stubb' French, Swiss, German and Sheffield Tools, Files and Steel Wire for Watchmakers, Jewelers, etc., 62 Chatham street, N. Y.
- Friedenthal, A. & Co.**—Importers and jobbers of Watchmakers' and Jewelers' Tools, Materials, etc. 43 Maiden Lane, N. Y.
- Friedlander, R. & L.**—264 Bowery—Importers of Watchmakers' tools and materials.
- Kurtz, F. P.**—Manufacturer of Jewelers Machinery, Tools, Rolling Mills, Presses, Polishing Lathes, &c. 97 Cliff St., N. Y.
- Levy, Dreyfus & Co.**—Importers and Jobbers of Watchmakers' and Jewelers' tools and materials of every description. 11 Maiden Lane, N. Y.
- Reichhelm & Koester.**—Importers of Jewelers' Tools, Files, etc. Manufacturers of Brushes and Buffing wheels; also Patent Gas Furnaces for Melting, Plating, Enamelling, Annealing, etc. 80 Nassau St., N. Y.

Lapidaries.

- Fox, M. & Co.**—Practical Lapidaries, No. 1 Maiden Lane, New York.
- Graham & Co.**—Practical Lapidaries, Cutters and Polishers of all kinds of Precious Stones. Miners' Relics Cut, Polished and Mounted. Miniature, Locket and Clock Glasses. 80 Nassau St., N. Y.
- Kordmann & Michel.**—Lapidaries. Dealers in Precious Stones. Cutting and Polishing Rubies, Sapphires and other Gems a specialty. Drilling done promptly. 59 Nassau St., N. Y.

Masonic Jewelry.

- Lennon, John D.**—Manufacturer of Masonic, Odd Fellows, Athletic Clubs and other Jewelry, No. 142 Fulton Street, New York.
- Luther, John F.**—79 Nassau Street. Manufacturer of Fine Presentation Jewels for all Societies. Knights Templars, Crosses, Badges, &c.
- Popper, H.**—Manufacturer of Medals and Badges for Military, G. A. R., Shooting, Masonic, Odd Fellows, Knights of Pythias, etc. 91 Essex St., New York.
- Wilkinson, C. B.**—Manufacturing Jeweler, 8 John St., N. Y. Medals, Badges and Masonic Jewelry, a specialty. Designs furnished free upon application.

Optical Goods.

- Friedlander, R. & L.**—264 Bowery. Dealers in Optical Goods.

Opticians.

- Burbank Manf'g Co.**—Manufacturers of Spectacles and Eye Glasses of all descriptions, in gold, silver, etc., 14 Maiden Lane, N. Y.
- DuBois, Geo. W. & Co.**—Importers of Watches and Optical Goods. 36 Maiden Lane, N. Y.
- Kahn, Hanover & Co.**—Importers of Spectacles, Eye-Glasses and Optical Goods generally, and Scientific Instruments of every description. 32 Maiden Lane, New York.
- Laurencott, J. B.**—Importer of Watch Glasses, Optical and Fancy Goods, Clocks, Bronzes, etc., 33 Maiden Lane, N. Y.
- Levy, Dreyfus & Co.**—Importers of Spectacles and Eye Glasses and Optical Instruments of every description, No. 11 Maiden Lane, N. Y.
- Lorsch, Albert**—Manufacturer of the Patent Accommodating Spectacles and Eye Glasses in Gold, Silver and Steel, and other Optical Goods, 37 Maiden Lane, N. Y.
- Major, W. E.**—Importer of Optical and Fancy Goods, Spectacles, Eye-Glasses, Silk Guards, Opera Glasses, Field Glasses, Telescopes, Etc. Also Dealer in Chains and Jewelers' Findings. No. 42 Maiden Lane, New York.
- New York Optical Co.**—Manufacturers of Spectacles, Eye-Glasses and Cases, No. 43 Maiden Lane, New York. (P. O. Box 2309).
- Spencer Optical Manufacturing Co.**—Gold, Silver, Steel, Nickel and Plated Spectacles; Gold, Celluloid, Steel, Nickel and Rubber Eye Glass and Opera Glasses. 13 Maiden Lane, N. Y.

Precious Stones, &c.

- Becker & Hahn.**—Importers of Precious Stones. Cameos, Intaglios, Seals, Black Onyx, etc. 26 John Street, New York.
- Bissinger, Philip & Co.**—Importer of Diamonds, Pearls and Precious Stones. Agent for the Bohemian Garnet Goods. Blue Enamelled Locketts. No. 22 John St., N. Y.
- Bishop, Victor & Co.**—33 Maiden Lane, Importers of Precious Stones, Cameos, &c. Also Manufacturers of Coral Jewelry.
- Breidenbach, R. A.**—Importer of Black Onyx, Cameos, Turquoise, Pearls, Sardonyx, Amethysts, Topaz, Garnets, Opals, Rubies, Sapphires, Cat's Eyes, Hematites, Brilliants, Doublets, etc. 85 Nassau St., N. Y., and 209 Friendship St., Providence, R. I.
- Daue, Wm. & Co.**—Importer of Precious and Imitation Stones. No. 202 Broadway New York.
- Fox, M. & Co.**—Importers of Diamonds and other Precious Stones, No. 1 Maiden Lane, N. Y.
- Gruet, Jules.**—Importer of all Grades of Real and Imitation Stones. 14 John St., N. Y.

Guntzburger Bros.—Manufacturers and importers of Precious Stones—Amethysts, Topaz, Cameos, Garnets, Imitation Diamonds, &c. No. 9 Maiden Lane.

Hahn & Co.—Importers of Precious Stones. Cameos, Onyx, Pearls, Intaglios, Amethysts, Garnets, etc. 64 Nassau Street, New York.

Kahn, L. & M.—Importers of precious and imitation stones. 10 Maiden Lane, N. Y.

Kipling, E. E.—Importer of Precious and Imitation Stones. Manufacturer of the Patent Foil Solid Metal Back Rhine Stone Brilliant. No. 6 Maiden Lane, N. Y.

Tannenbaum, L. & Co.—Manufacturers of Fine Jewelry, and always on hand a specialty of Precious Stones and all kinds for jobbing. 65 Nassau Street, New York.

Silverware.

- Gorham Manufacturing Co.**—Union Square.
- Knowles, J. B. & S. M.**—Manufacturers of Sterling Silverware, 20 Maiden Lane, N. Y. Factory, Providence, R. I.
- Shiebler, Geo. W.**—Manufacturer of Sterling Silverware. No. 8 Liberty Place, near Maiden Lane, N. Y.
- Wood & Hughes.**—Manufacturers of Fine Silverware. 16 John Street, N. Y.
- Whiting Manufacturing Co.**—Makers of Sterling Silver Ware. Broadway cor. 4th Street, N. Y.

Silver Filigree Jewelry.

- Cuppia, L. A.**—Manufacturer of Solid Silver Novelties, and Importer of Silver Filigree, 19 Union Square.
- Hartmann, P.**—Manufacturer of Silver Filigree Jewelry. 36 Maiden Lane, N. Y.

Silver Plated Ware.

- Holmes, Booth & Haydens**—Manufacturers of Silver-Plated Ware. 47 Chambers Street.
- Manhattan Silver Plate Co.**—Manufacturers of Silver Plated Ware. Showrooms, 23 John St. Factory, 301 to 305 East 22d St., cor. 2d Ave. Address all communications to Factory.
- Meriden Britannia Co.**—Manufacturers of Silver-Plated Ware. 46 East 14th Street, Union Square.
- Meriden Silver Plate Co.**—Manufacturers of Fine Silver Plated Ware. No. 30 E. 14th Street, New York.
- Middletown Plate Co.**—Manufacturers of Superior Electro-Plate. Factories, Middletown, Conn., salesroom, 13 John Street.
- Rogers & Bro.**—Manufacturers of the finest quality of Electro-Plated Ware. 690 Broadway.
- Rogers, Smith & Co.**—Manufacturers of Fine Electro Plated Ware. No. 46 E. 14th St., N. Y.
- Simpson, Hall, Miller & Co.**—Manufacturers of fine Silver-Plated Ware. No. 36 E. 14th Street.
- Schade, Henry.**—Manufacturer of White Metal and Plated Ware. No. 84 John St., N. Y. Price list and catalogue furnished on application.
- Webster, E. G. & Bro.**—Manufacturers of Fine Silver-Plated Ware. Office and warerooms, 14 Maiden Lane, N. Y.

Show Cases, Etc.

- Hoffman, Geo. A.**—Manufacturer of Show Cases. All the latest improved styles on hand and made to order. Celluloid show cases a specialty. Send for catalogue. 148 Chatham Street, New York.
- Smith, B. & W. B.**—Manufacturers of Patent Improved Dust Proof Show Cases, with Perpendicular Sliding Doors, No. 220 W. 29th St., N. Y.

Spectacle Case Manufacturers.

- Bertine, P. D.**—Manufacturer of Spectacle Cases, 139 William Street, near Fulton St., New York.
- Koenen, A. & Bro.**—Manufacturers of Leather Spectacle and Eye-Glass Cases. 81 Nassau St., N. Y.

Stem Winding Attachments.

- Abbott, Henry** Maker of Stem Winding Attachments, No. 7 Maiden Lane, N. Y.

Thermometers, Etc.

Tagliabue, Giuseppe.—manufacturer of Thermometers, Barometers and Hydrometers. Patentee and sole manufacturer of the U. S. Standard Hydrometer. 302 Pearl Street, near Beekman.

Thimble Manufacturers.

- Barker Manufacturing Co.**—Manufacturers of Patent Graduated Thimbles, Stiffened Gold, Filled Gold, and Rolled-Plate Gold. 36 Maiden Lane, N. Y. A. Lyons, Agent, Manufactory 19 Snow Street, Providence, R. I.
- Burbank Manufg Co.**—Manufacturers of Gold and Silver Thimbles, 14 Maiden Lane, N. Y.
- Ketcham & McDougall.**—Improved Gold and Silver Thimbles, Nos. 4 and 6 Liberty Place, near Maiden Lane, N. Y.
- Simons Bro. & Co.**—Manufacturers of Gold and Silver Thimbles. 611 and 613 Sansom Street, Philadelphia.
- Woglom & Miller.**—Sole Agents for the "Prime" Thimbles in Gold and Silver, manufactured by Ezra C. Prime. 34 John Street, N. Y.

Watch Companies.

- American Watch Co.**—Robbins & Appleton, No. 5 Bond Street, N. Y.
- The E. Howard Watch and Clock Co.**—Cor. Maiden Lane and Nassau Street, N. Y.
- Waterbury Watch Co.**—Manufacturers of the Waterbury Watch. Factory, Waterbury. Office, 4 Maiden Lane, N. Y.

Watch and Chronometer Jeweler.

- Queen, James.**—Watch and Chronometer Jeweler and Pallet Maker, 78 Nassau Street, room 8. Pivots inserted in Pinions, Balance, Staffs, etc.
- Wenstrom, John.**—Watch, Chronometer and Clock Jeweling, Jewel Guages, Ruby and Sapphire Draw Plates; Diamonds Dressed; Polishing Stones for Jewel Settings. 2 Dutch St., N. Y.

Watch Importers, Etc.

- Abry, Chas. Leo**—Importer and Manufacturer of Swiss Watches of all grades. 63 Nassau Street.
- Aikin, Lambert & Co.**—Importers of Watches. Sole Agents for Paul Breton & Chas. Latour, Geneva. A general line of reliable Swiss Watches, Watch Cases, etc. 23 Maiden Lane, N. Y.
- Bartens & Rice**—20 John Street, Importers of Watches and sole agents in the United States for the celebrated Nicole, Nielsen & Co. Watches.
- Cross & Beguelin.**—Importers of Watches, Watch Tools and Materials, dealers in American Watches, No. 21 Maiden Lane, N. Y.
- Droz, Henry E.**—Importer of Watches, and Watch Case Manufacturer. Agent for the "E. Perregaux" Watch, and jobber in American Watches. No. 92 Fulton Street, N. Y.
- Durfey & Reynolds**—Successors to Durfey & Shiebler, Watches, Diamonds, Jewelry. No. 9 John Street, (np-stairs) New York.
- Freund Max & Co.**—Importers of Watches, Jewelry and Precious Stones, 8 Maiden Lane, N. Y.
- Gagnebin, Chas.**—Importer of all kinds of Swiss, and Dealer in American Watches. 4 Maiden Lane, N. Y. Agent for Ulyse Breting's Fine Chronometers, Chronographs, Anchors, &c.
- Gallet, Julien.**—Importer of Watches. No. 1 Maiden Lane.
- Ginnel, Henry**—Importer of Watches, Tools and Materials, 31 Maiden Lane, N. Y. P. O. Box, 2067
- Heinrich, H. H. & Co.**—Sole Agents for the Karl Zimmerman Watch, and Importers of Fine Watches and Marine Chronometers. 12 John Street, N. Y.
- Herzog, Louis & Co.**—Importers of Watches, Dealers in Diamonds and Jewelry, 52 Maiden Lane, N. Y.
- Hirsch Bros.**—Dealers in Watches and Diamonds and Manufacturers of Jewelry, No. 23 Maiden Lane, N. Y.
- Hyde's Sons, John E.**—Wholesale Commission Agents, only for Jnles Jurgensen, of Copenhagen; Jules Monard, of Geneva; and for other makers of all qualities of Watches, 22 Maiden Lane.

Jandorf, P. & Bro.—Importers of Watches and Jewelry, 196 Broadway.

Keller, L. H. & Co.—Successors to G. A. Huguenin, Importers of Fine Watch and French Clock Materials, No. 64 Nassau Street, N. Y.

Mathey Bros. & Mathez.—Importers of Fine Watches and Sole Agents for the **H. L. Matile's** Watches. No. 16 Maiden Lane.

Oppenheimer Bros. & Veith.—Dealers in Watches and Diamonds, and Manufacturing Jewelers, No. 35 Maiden Lane.

Robert, J. Eugene—No. 30 Maiden Lane, New York. Agent for Louis Audemar's celebrated watches.

Schwob, Adolphe—Manufacturer and Importer of Watches, 11 Maiden Lane, N. Y.

Stern Brothers & Co.—Importers of Swiss Watches and wholesale dealers in American Watches, &c., 39 Maiden Lane.

Scott, J. T. & Co.—Importers of Watches, and Manufacturers of Jewelry, and Jobbers of all Grades of American Watches, 11 Maiden Lane.

Strasburger, Louis & Co.—Importers and Makers of Watches of every description, 15 Maiden Lane.

Watch Cases.

Brown, J. A. & Co.—Manufacturers of the Ladd Patent Stiffened Gold Watch Cases, etc., 11 Maiden Lane, N. Y. Factory, 58 Eddy Street, Providence, R. I.

Dueber Watch Case Mfg Co.—Manufacturers of Gold and Silver Watch Cases. No. 16 Maiden Lane, N. Y. Factory, Newport, Ky.

Fahys, Joseph—Manufacturer of Watch Cases and Dealer in American Movements, 38 Maiden Lane.

Hagstoz & Thorpe—Manufacturers of Boss' Patent Gold and Keystone Silver Cases. 14 John Street, New York.

Keller & Untermeyer.—Manufacturers of Watch Cases with Raised Gold Ornaments. 9 Maiden Lane, N. Y.

Willemin Watch Case Co.—Makers of Gold Watch Cases. Raised Gold Ornamentation and Jurgensen style of Engine Turning. 109 Sands Street, Brooklyn, N. Y.

Watch and Chronometer Repairers.

Cerf, B.—Practical Watchmaker and Repairer, No. 10 John Street, N. Y. Repairing and adjusting of Fine Watches done for the trade. All kinds of escape and stem-winding wheels cut to order.

Heinrich, H. H. & Co.—Sole Manufacturers of H. H. Heinrich's Patent Auxiliary Balance, and Adjusters and Repairers of Fine Watches and Chronometers. 12 John Street, N. Y.

Lesperance, Theo.—Watchmaker and Wheel Cutter. Also Stoning Nickel Movements. No. 1 Maiden Lane, New York. With Julien Gallet.

Ludeman, W. H.—Chronometer and Watch Maker. Repairing of every description for the trade, 75 and 77 Nassau Street.

Watch Case Repairers.

Feinier, Joseph A.—Watch Case Maker and General Repairer. Specialty in fine Gold and Silver Cases. Jobbing promptly attended to. Nos. 4 and 6 John St., N. Y.

Tarbox, Hiram—Watch Case Repairing, Springing, Polishing and Engine Turning, 79 Nassau Street, also Fourth Ave., bet. 176th and 177th Sts., N. Y.

Watch Glasses, Shades, Etc.

Brown, Edwin H.—No. 85 Nassau Street, Imported and Own Manufacture Watch Glasses, Flat, Flat Concave, Concave, Convex and fine Geneva's. Fine fitting solicited.

Watches, Jewelry, etc.

Cohn, J. J.—Importer and Manufacturer of Whitby Jet, Rubber and Pearl goods. Gold and Rolled-plate Jewelry, etc. 12 Maiden Lane, New York.

Friedman, Saml.—Wholesale Dealer in Watches and Jewelry, 42 Maiden Lane, N. Y.

Fry & Schieber—Manufacturers of Fine Gold and Plated Jewelry and Importers of Watches, 201 Broadway, N. Y.

Leberthon, L. M.—Importer of diamonds and watches. Manufacturer of jewelry. 14 John St. Fine stones a specialty.

Lissauer & Sondheim—Wholesale Jewelers and Jobbers in American Watches, No. 12 Maiden Lane, N. Y.

Marx, Kossuth & Co.—Importers of Watches and Dealers in Jewelry. 39 Maiden Lane, N. Y.

Mayer, B.—Manufacturer of Fine Jewelry, and Dealer in Watches, 71 Nassau street, cor. John street, New York.

Mayer, Max.—Dealer in Gold and Fine Rolled Plate Jewelry of every description. 71 Nassau St., N. Y.

Myers, S. F. & Co.—Manufacturing and Wholesale Jewelers—all grades. Importers of Watches. Illustrated Catalogue to the trade. 179 Broadway, N. Y.

Stern & Stern—Dealers in Watches, Jewelry and Diamonds. No. 6 Maiden Lane, N. Y.

Strauss, Jacob.—Full Line of Gold and Plated Jewelry, and Importer of Watches. 18 John Street, New York.

Trier Bros.—Importers of Garnet, Whitby Jet and Amber Jewelry, Silk Guards, Opera, Field and Marine Glasses, Pearl Card Cases. Also a full line of Gold and Plated Jewelry. 15 Maiden Lane, N. Y.

White, N. H.—Jobber in American Waltham Watches and Chronographs. Waltham make of 14-k. and 18-k. Gold and Sterling Silver Cases. Filled 10-k. and cheap Gold Cases. 11 Maiden Lane, N. Y.

Watch Tools, etc.

Gesswein, F. W.—Manufacturer of Machinery and Tools for Jewelers, Watch, Clock and Watch Case Makers, etc. 39 John Street, N. Y.

Keller, L. H. & Co.—Importers of Watchmakers' and Jewelers' Tools, Materials, etc. 64 Nassau Street, N. Y.

Zimmern, Henry—Importer of Watch Materials, Tools, and Optical Goods, No. 8 Maiden Lane, (first floor.) Sole Agent for A. Huguenin & Gravier. Mainsprings, New York.

PHILADELPHIA

Booz & Co.—Manufacturers of Gold and Silver Watch Cases and Jewelry, 108 South 8th St., Philadelphia.

Bennett, Jacob & Son.—Diamond Setters and Manufacturing Jewelers, 925 Chestnut St.

Bernard & Co.—Manufacturers of fine Roman and Etruscan Jewelry. Designs of every description made to order, 123 & 125 South Eleventh Street, Philadelphia.

Birmingham, Wm. & Co.—Morocco Case Manufacturers. Spectacle and Eye-Glass Cases a specialty, 626 Arch Street, Philadelphia, Pa.

Clark, J. L.—Gold and Silver Refiner and Assayer; Sweep Smelter. Gold and Silver or Platinum bought. 823 Filbert Street, Philadelphia.

Conover David F. & Co.—American Watches, Wholesale Salesroom, Southeast corner 7th and Chestnut Streets, Philadelphia.

Dubosq, J. Carrow—Manufacturer of Fine Jewelry. Particular attention given to repairing Strung Pearl work. 108 South Eighth St., Phila.

Fick, Chas. M.—Stone Seal Engraver. Coats of Arms, Crests, Monograms, Initial Letters and Masonic Emblems, and other devices engraved on all kinds of Precious Stones. Cameos cut and repaired. 618 Chestnut Street.

Goldsmith, M. L.—Importer and jobber of Watch Materials, Tools, etc. 722 Chestnut St., Philadelphia, Pa.

Guilbert, Thos. M., & Co.—Manufacturing Jewelers. Flexible Bracelets and Strung Pearl Repairing. 908 Chestnut St., Philadelphia.

Hagstoz & Thorpe—Manufacturers of Boss' Patent Gold and Keystone Silver Cases. 19th and Brown Streets, Phila. New York office, 14 John St.

Herold, Chas P.—Successor to Hildebrandt, Herold & Co., Manufacturing Jeweler and Diamond Setter. Diamonds, 916 Chestnut Street.

Krieder, Peter L.—Manufacturer of Sterling Silver Ware. 618 Chestnut Street, Philadelphia.

McCarty & Hurlburt—Manufacturers of Gold Spectacles, Silver Thimbles and Plain Rings. Wholesale dealers in American Watches, Jewelry, etc. 131 North Second Street.

Morgan & Headly.—Manufacturing Jewelers, Cameo Sets, Gold Sets, Roman Lockets, Rings, Coral Sets and a general line of rich goods. Corner 10th and Chestnut Streets, Philadelphia.

Morgan, Charles V.—Manufacturer of Morocco and Hardwood Cases. 550 Chestnut Street, Philadelphia. Jewelry and Silverware Cases, Show Case Trays, Mathematical and Surgical Instrument Cases, etc.

Morris, William—Importer of Watch Materials, Tools, Glasses, Spectacles, White Metal and Plated Chains. The attention of the closest buyers is requested. 706 Chestnut St., Philadelphia.

Muhr's, H. Sons.—Manufacturing Jewelers. Solid Gold and Filled Rings a specialty. 633 and 635 Chestnut Street, Philadelphia. 1½ Maiden Lane, New York.

Peters, Reese S.—Manufacturer of Patent Rolled Plate or Filled Watch Cases, Dealer in American Movements, 308 Chestnut Street, Philadelphia.

Robeth, A.—Wholesale Optician, and Dealer in Fine and Plated Jewelry, also Diamonds and Swiss Watches. 825 Market St., Philadelphia.

Rowe, Geo. A.—Stone and Metal Seal Engraver, Die Sinker and Medalist, Intaglio Cutting. Special rates for large quantities to manufacturers. 1002 Walnut Street.

Rosenthal, G. F. C.—Manufacturing Jeweler and Diamond Setter. Engraving and Designing of Monograms a Specialty. No. 917 Sansom Street.

Scherr, L. A. & Co.—Wholesale Dealers in Watches Silver-Plated Ware, Spectacles, Fancy Goods, Watch Materials, etc. 726 Chestnut Street.

Sheafer, W. H. & Co.—Manufacturing Jewelers. Specialty: Band Bracelets. Factory and office—612 and 614 Chestnut street, Philadelphia. Branch office—15 John street, New York.

Simons, Brother & Co.—Manufacturers of Fine Jewelry, Cans, Thimbles, Chains. 611 and 613 Sansom Street.

Vansant, John T. & Co.—611 and 613 Sansom Street, Artisan Hall, Manufacturers and Wholesale Dealers in English Sterling Silverware. Specialties: Tea Sets, Knives, Forks, Spoons, Cups and Napkin Rings.

CHICAGO.

American Watch Company,—of Waltham, Mass. No. 170 State Street, Chicago.

Chicago Watch Case Co.—Manufacturers of Patent Dust Proof Screw Bezel Watch Cases. Cor. Madison Street and Michigan Avenue, Chicago, Ills.

Clapp, Caleb & Co.—Wholesale Jewelers, 63 and 65 Washington Street. Catalogue and price list issued to watchmakers and jewelers.

Cogswell & Wallis, Ag't—Dealers in Clocks, Watches, Jewelry, Silver and Plated Ware, Watch Tools, Materials and Optical Goods, 146 State Street, Chicago.

Dennison Manufacturing Co.—Manufacturers of Jewelers' Paper Boxes, Morocco Cases, Tags, Cards, Pink and White Cotton, Tissue Papers, Sealing Wax, &c., &c., 102 Madison St., Chicago. Boston, New York, St. Louis, and Philadelphia.

Excelsior Sign Co.—Manufacturers of Iron and Wood watch and clock signs. No. 126 Fifth Avenue, Chicago, Ills.

Gilbert, Wm. L., Clock Co.—Manufacturers of Clocks, Regulators, and Time Pieces, and Clock Material of every description, 54 and 56 Madison Street, Chicago.

Giles, Bro. & Co.—Manufacturers and Jobbers in Watches, all classes of Jewelry, Materials, Clocks, Silver Ware, &c. Illustrated catalogues furnished to dealers on application. State and Washington Streets.

Hagstoz & Thorpe—Manufacturers of Boss' Patent Gold and Keystone Silver Cases. H. M. CARLE, Agent, 67 Washington St.

Kearney, Theodore—133 and 135 State Street. Importer and Jobber of Watchmakers' and Jewelers' Supplies, Watches, Jewelry, etc. Illustrated catalogue and price list sent on application and receipt of card.

Stein & Ellbogen—Wholesale Dealers in Watches and Jewelry, 127 State Street, Chicago, Ill. Specialty, repairing for the trade.

Wathier, Joseph P.—Watchmakers and Jewelers for the trade, and Wholesale Dealers in Watch Materials, Tools, etc. 178 West Madison Street, Chicago, Ill. Send for price list.

Welch, E. N. Mfg. Co.—6 Warren Street, New York, E. C. Hine, Treasurer and General Manager, 69 Washington Street, Chicago. F. E. Morse, Agt.

Wendell, Charles & Son—Wholesale Watches, Jewelry, etc. 170 State street, Chicago.

NEWARK.

Alling, Isaac A. & Co.—Manufacturers of Diamond and Fine Gold Jewelry, Sets, Lace Pins, Ear Rings, Studs, Rings and Buttons. Specialties: Wire Bracelets, Bangles and Scarf Pins. 50 Walnut Street, Newark.

Baker & Co.—Gold and Silver Refiners, Assayers and Sweep Smelters. 104 New Jersey Railroad Avenue, near Green St., Newark, N. J.

Diefenthaler Bros. & O'Donnell—Manufacturers of Fine Jewelry, Lace Pins, Ear Rings and Patent Spring Bangles a Specialty. 36 Crawford Street, Newark, N. J.

Felger, F. & F.—Manufacturing Jewelers. Specialties:—Roman Band Bracelets, Lace Pins, Scarf Pins, Ball and Fancy Ear Rings. No. 477 Washington Street, Newark, N. J.

Fiedler, Herrman—Successor to Kunze & Fiedler, Engraver, Die Sinker and Press Tool Maker, 303 Market Street, Opposite Pennsylvania R. R. Depot, Newark, N. J.

Herpers Bros.—Manufacturers of Settings, etc. 18 Crawford Street, Newark, N. J.

Hopper & Valentine—Manufacturers of Fine Jewelry, No. 8 Maple Place, Rear 44 Green St., Newark, N. J.

Hüger & Heitlinger.—Manufacturers to the Jobbing Trade only. Makers of Roman Stone, Engraved and Enameled Locketts, also Sets, Lace Pins and Ear Rings. Rear 477 Washington St.

Krippendorf, C. & Schuller, F.—Machinists and Jewelers' Tool Makers. 19 Greene Street, Newark, N. J. Rolls, Dies, Cutters, and Drawplates of every Description made and repaired.

Lefort, Henry.—Stem-winding Watch Crown Manufacturer. 60 Arlington Street.

Lelong, L. & Bro.—Gold and Silver Refiners, Assayers and Sweep Smelters, Southwest corner of Halsey and Marshall Streets, Newark, N. J.

Miller & Beam.—Manufacturers of Enameled Sets, Ear Rings, Lace Pins, etc. Guard Slides and Pendants a Specialty. 21 and 23 Green Street.

Milne, Alex.—Manufacturer of Stem-winding Watch Crowns. 19 Ward Street.

Pollock, T. H.—Manufacturer of Jewelers' and Silversmiths' Wheel Brushes, Buffs, etc. No. 36 Crawford Street, Newark, N. J.

Regad, E. D.—Lapidary. Specialty—Sardonyx, Black Onyx and Agates. 14 Oliver St., Newark.

PROVIDENCE

Irons, Chas. F.—Manufacturer of Solid Gold Jewelry. Specialty, Emblems, Pins and Charms, Masonic, Odd Fellows, etc. 102 Friendship St.

Lederer, S. & B.—Manufacturers of Fire Gilt, Nickel, Electro and Silver Plated Chains, Necklaces, Charms, etc. Opera, Matinee and Guard Chains. 66 to 72 Stewart St., Providence, R. I.

Pearce & Hoagland.—Manufacturers of Gold Pens, Holders, Pencils, Tooth Picks, etc. Also the Quill Reserve Tooth Pick. 29 Point Street, Providence, R. I.

Smith, Wm. T.—Assayer, Refiner and Sweep Smelter. Established 1855. Blackstone and Hawkins Streets, Providence, R. I.

Taylor, Geo. H. & Co.—Watchmakers and Wholesale Dealers in Watches, Clocks, Watch and Clock Material, Tools, Spectacles, Eye Glasses, &c. Particular attention given to trade work. 136 Westminster Street (Room 1), Providence, R. I.

PAWTUCKET.

Draper, J. O. & Co.—Manufacturers of Jewelers' Fig Soap, adapted for Washing Jewelry, Scratch Brushing and Drawing Wire. Pawtucket, R. I.

Fuller, Geo. H. & Son—Jewelers' Findings, Gold, Silver, Gold Plated and Fire Gilt. Pin Stems, Joints, Catches, Split Rings, Chain Hooks and Swivels, Ear Wires, Chain Bars, etc. 99 Exchange Street, Pawtucket, R. I.

Thayer, Ellis & Son—Brush Manufacturers, and Wholesale Dealers in all kinds of Brushes. Sole manufacturers of Ellis Thayer's Patent Polishing Wheels. Manufacturing Jewelers' and Machine Brushes a Specialty. 80 North Main Street, Pawtucket, R. I.

Thayer, P. E. & Co.—Manufacturers of Brushes. Jewelry and Machine Brushes a Specialty. All kinds of Wire Scratch Brushes on hand. Orders by mail or otherwise promptly attended to. 34 East Avenue, Pawtucket, R. I.

CINCINNATI.

Awalt, John A.—Jobber in Watches, Clocks, Jewelry, etc., 173 Vine Street, Cincinnati.

Dahme & Co.—Goldsmiths, Silversmiths and Diamond Setters. 4th and Walnut Streets, Cincinnati, Ohio.

Lodwick & Nolting—Wholesale Jewelers, S. W. cor. 4th & Walnut Streets, Cincinnati.

Noterman & Jonas—Manufacturing Jewelers, cor. 4th and Main Streets. Manufacturers of the Ophir Diamond Jewelry.

BOSTON.

Boyce & Wainwright—Manufacturers of Solid Gold Jewelry. Rings a Specialty. 383 Washington Street, Boston, Mass.

Smith, Wm. A.—Importer of Diamonds and Precious Stones. Diamonds mounted and unmounted and Diamond Mountings. 383 Washington St., Boston, Mass.

SPRINGFIELD.

Bullock, O. W.—Springfield, Mass. Manufacturer of Fine Nickel Plated Watch and Jewelery Tools, Keys, and Light Metallic Goods.

NORTH ATTLEBORO.

Whiting, F. M. & Co.—Manufacturers of Sterling Silver Ware and Jewelry, North Attleboro, Mass.

LANCASTER.

Bowman & Musser—Jobbers in Watches, Clocks, Chains, Fine Tools and Materials. 20 East Chestnut Street, Lancaster, Pa.

PITTSBURGH.

Goddard, Hill & Co.—Wholesale Dealers in American Watches, Jewelry, Silverware, Clocks, Materials, &c., 43 Fifth Avenue, Pittsburgh, Pa.

BALTIMORE.

Morris, Wm. & Co.—Importers and Jobbers of Watch Materials, Tools, Optical Goods, Plated and White Metal Chains. Agents for American Lathes, &c. The attention of Southern Trade is requested. 207 and 209 West Baltimore Street.

CANADA.

Ellis, P. W. & Co., No. 31 King street, East Toronto, Ontario, Manufacturing Jewelers, Watchmakers, importers and Jobbers of Watchmakers, and Jewelers' Tools, Materials, General Supplies and American Jewelry. Correspondence solicited with manufacturers of Novelties or specialties in American Tools and Jewelry.

POSITIVELY NO GOODS RETAILED.

BOWMAN & MUSSER,

SUCCESSORS TO

E. F. BOWMAN,

JOBBERS IN

Watches, Clocks, Chains,

Fine Tools and Materials,

20 E. CHESTNUT STREET,

Cop. P. R. R. Passenger Depot,

LANCASTER, PA.

Selection Packages sent to Regular Jewelers on Request.

Twenty-Third Annual Statement OF THE

Washington Life Insurance Company,

W. A. BREWER, Jr., President.

Net Assets, December 31, 1881.....	\$5,826,712 19
Receipts during the year for	
Premiums.....	\$1,278,000 56
For interests, rents, &c.....	351,969 17
	1,630,969 73

7,456,681 92

Disbursements:	
Claims by death.....	\$157,930 03
Matured and discounted endowments	138,263 59
Surrendered policies, cash dividends and return premiums..	466,650 83
Annuities.....	1,419 29
	\$1,064,263 74
Taxes	11 202 63
Committed commissions	34,214 28
Profit and loss.....	6,586 54
Dividends to Stockholders.....	8,653 75
Expenses, rent, commission, salaries, postage, Advertising, medical examinations, &c.....	236,571 11
	1,361,492 05

Net Assets, Dec. 31, 1882.....\$6,095,189 87

ASSETS.	
U. S. and N. Y. city stocks.....	\$1,291,921 30
Bonds and mortgages, being first liens on real estate valued by the Insurance Department at \$3,793,750.....	3,885,613 02
Real estate.....	487,499 70
Cash on hand, in banks and Trust Co.....	322,483 64
Loans on collaterals.....	65,117 36
Agents' balances.....	39,574 85
	\$6,095,189 87

Add excess of market value of Stocks over cost.....	249,311 20
Market value real estate in excess of cost as per department valuation.....	27,015 66
Interest accrued, and due and unpaid.....	41,825 35
Deferred and unpaid premiums less 20 per cent.....	160,647 92
	\$6,574,020 00

Gross assets Dec. 31, 1882.....\$6,574,020 00

LIABILITIES.	
Reserve by N. Y. Standard Company's valuation.....	\$5,591,839 00
Unsettled claims.....	41,566 57
Premiums paid in advance.....	4,611 16
Unpaid dividends to Stockholders.....	271 25
Unpaid expenses.....	2,540 00
Surplus as regards policy-holders.....	930,192 02
	6,574,020 00

Policies issued in 1882.....	2,828
Policies issued in 1881.....	2,076
Amount of insurance in 1882.....	\$6,457,795
Amount of insurance in 1881.....	4,681,460
Total number of policies in force.....	13,395
Total amount insured, with additions.....	29,374,019

W. HAXTON, Vice-President and Secretary.
 CYRUS MUNN, Assistant Secretary.
 E. S. FRENCH, Supt of Agencies. I. C. PIERSON, Actuary.
 B. W. MCCREADY, M.D., Medical Examiner
 FOSTER & THOMSON, Attorneys.

To lessen losses by forfeiture, when premiums are due and unpaid, this Company voluntarily applies as premium, in all cases, the cash value of the dividends to the credit of each policy, to the continuance of such policy for days, months, or years, as the case may be; and during that time the insured may resume his payments without a re-examination.

This is a protection which no other Company affords.



Copyright Secured.

PATENT IMPROVEMENT IN
COUNTER + SHOW + CASES,
 WITH PERPENDICULAR SLIDING DOORS. DUST PROOF.



The Advantage and Convenience of these Show Cases will be apparent to everyone.

The doors are more conveniently opened and closed, less liable to get out of repair or broken, articles are more easily reached in wide cases, mirrors are more safe, it dispenses with hinges, economizes room, excludes dust, and is air tight when closed.

Drawings furnished and estimates given for fitting stores in cabinet work complete.

Letters Patent having been granted us for the construction of these doors, we shall prosecute all parties using Cases which infringe on our Patents.

REFERENCES:—Gorham Mfg Co., Rogers & Bro., Mitchell Vance & Co.,
 Meriden Britannia Co., M. S. Smith & Co., Detroit, Mich.
 D. Valentine, Syracuse, N. Y.

B. & W. B. SMITH,
220 West 29th Street, New York.

M. Anderson, No. 37 State Street, Chicago, has the exclusive right to manufacture and sell our Improved Cases for the States of Wisconsin, Illinois, Missouri, Mississippi, Arkansas, and all States West of same.

CATALOGUE OF STYLES SENT ON APPLICATION.

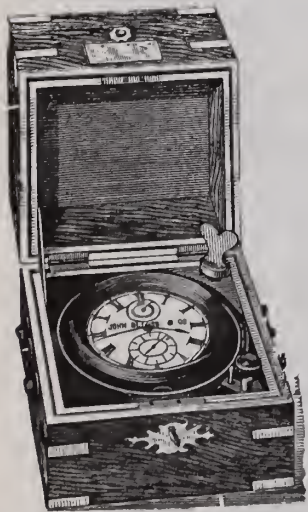

Standard Marine Chronometer
 FOR KEEPING CORRECT TIME.

JOHN BLISS & CO.,
Standard Marine
CHRONOMETERS AND TRANSITS
FOR WATCHMAKERS' USE.

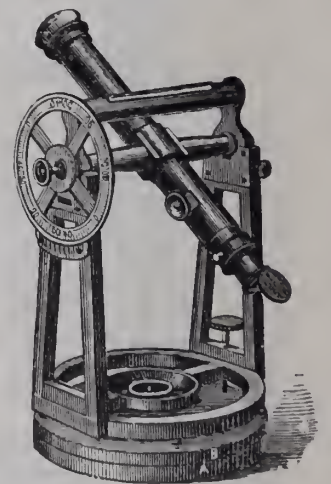

No. 10

128 FRONT STREET, NEAR WALL STREET, NEW YORK.

IMPORTANT NOTICE.—These Transits are readily set in position without the aid of strictly correct time as a basis for that purpose. Printed instructions, easily understood, accompany each Instrument, and no calculations are required preliminary to setting in position.

As a trial only is required to insure unqualified approval, we are induced to make the following **LIBERAL OFFER**—On receipt by us of satisfactory reference, and 10 per cent. of the price, we will send one of the foregoing Transit Instruments, on hire or trial, for one month, with full printed instructions for setting up and using the same, and if purchased after trial, we will allow the whole hire to apply in part payment, and sell the Instrument on approved note at four months for the balance. Special terms for payment by installments, after trial, on application. We do not make this offer merely to hire these instruments, but to insure a trial with a view to sales, the hire received being only sufficient to cover the cost of repolishing in case they are returned. Send for Illustrated Circular giving full description.

JOHN BLISS & CO., 128 Front Street, (between Wall and Pine Sts.) New York.

"THE JEWELERS' MERCANTILE AGENCY."

D. L. SAFFORD,

Mercantile and Collection Agency

214 & 216 BROADWAY, N. Y.

AND 5 CUSTOM HOUSE ST.,

PROVIDENCE, R. I.

OUR REFERENCE BOOK CONTAINS the names of nearly every Jeweler in the United States, with ratings of Capital and Credit; street addresses in cities, &c.

WE FURNISH TO SUBSCRIBERS a Weekly sheet of changes and corrections, and special detailed Reports as to financial standing and credit of customers.

CONFINING OUR BUSINESS entirely to the Jewelry and kindred trades, we feel that we are qualified to furnish more accurate Reports than other Agencies.

OUR SYSTEM OF RATINGS is different from other Agencies, as we give especial attention to ratings for Credit, which we believe should not be based or dependent on Capital alone.

*Our Terms of Subscription are less than those of other Agencies,
and will be made known on application.*

ESTABLISHED 1869.

THE JEWELERS' CIRCULAR

—AND—

HOROLOGICAL REVIEW.

THE RECOGNIZED ORGAN OF THE

Watch, Clock, Jewelry and Kindred Organizations of the U. S.

*Published Monthly at \$2.00 Per Annum to all parts of the United States and
Canada, and \$3.00 Per Annum to all Foreign Countries.*

To the Country Dealer THE JEWELERS' CIRCULAR affords thorough, correct and perfect information as to Staple and Original Articles of Trade. From it he can learn what to order and where to obtain supplies, he can discover the best source of materials in common use, while the latest novelties are without exception first announced in its columns.

To the Practical Workman THE JEWELERS' CIRCULAR is invaluable as a Text-Book and Work of Reference. It furnishes him with the Latest Scientific and Mechanical Ideas, set forth in plain, comprehensive language by specialists of ability and experience. The technical information contained in its columns represents the progress of the age, and every intelligent workman in the country acknowledges the advantages resulting from a study of its pages.

The 14th Volume of THE JEWELERS' CIRCULAR commenced with the February, 1883, issue, and will surpass in interest all previous volumes.

D. H. HOPKINSON,

Editor and Proprietor,

42 NASSAU STREET, N. Y.

WATERBURY CLOCK CO.,

MANUFACTURERS OF

CLOCKS,

Novelties and Materials,

No. 10 CORTLANDT ST., N. Y.

— AND —

No. 63 WASHINGTON ST., CHICAGO.

Factories, **WATERBURY, CONN.**

M. BAILEY, Treasurer.

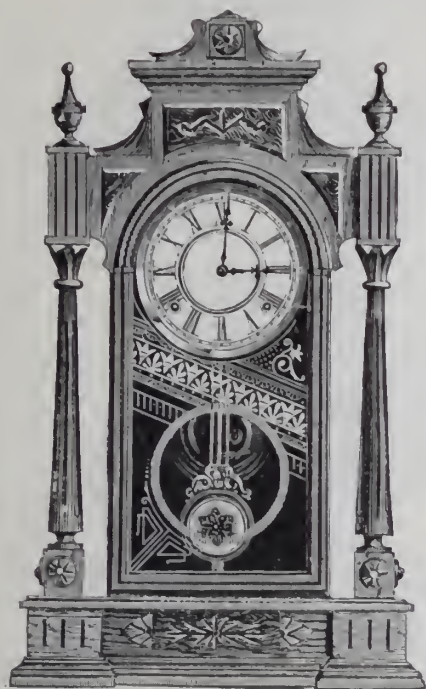

RAPIDAN.

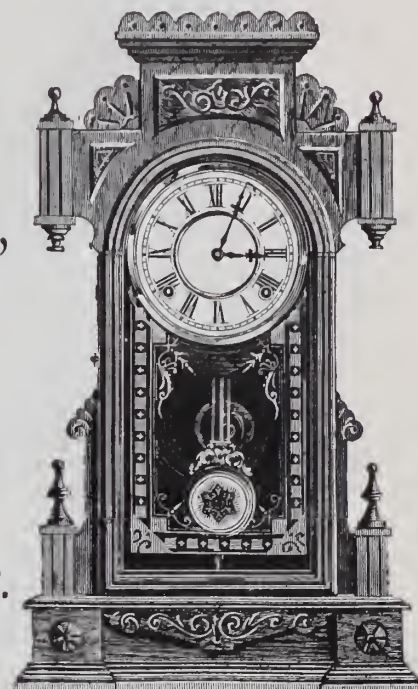

DUNKIRK.

The Ansonia Clock Co.,

Nickel Clocks.

Wood Clocks.

Iron Clocks.

Marbleite Clocks.

Pillar Clocks.

Tower Clocks.

Catalogue and Price List

FOR 1883

Sent on Application.

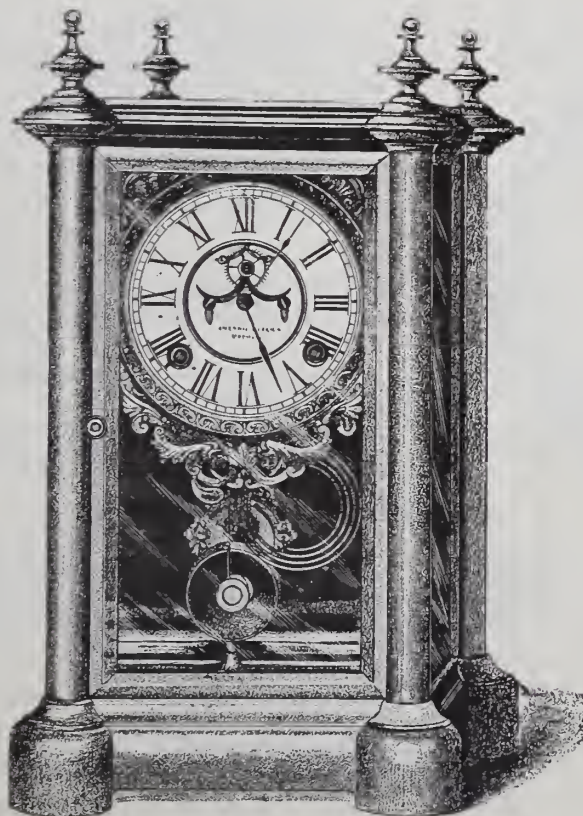

SYMBOL EXTRA.

BRONZES.

CHICAGO,
64 Washington St.

LONDON,
128 Minories.

NEW YORK,
11 to 19 Cliff Street.

W. L. GILBERT CLOCK CO.,

GEORGE B. OWEN, General Manager.



LEBANON.—Walnut.
8 Day Strike.
Height 20½ inches. 6 inch Dial.

Salesrooms:

No. 6 Murray St., N. Y.
54 & 56 Madison St., Chicago.

Factories:

WINSTED,
Conn.

MANUFACTURERS OF

Walnut, Veneered and Other Clocks

IMPORTERS OF

Marble and Cuckoo Clocks.

*Catalogue and Price List Fur-
nished upon application.*



ENID.—Walnut.
One Day Strike.
Height, 21½ inches. 6 inch Dial.

Grout's Excelsior Louis XIV.

WATCH SIGN,

Manufactured only by the

Excelsior Sign Co.,

CHICAGO.

Finished with the Best

XX GOLD LEAF,

AND

WARRANTED

To Stand in

Any Climate.



Handsome,

Cheap

AND

Durable.

SIZES AND PRICES.

12 Inch.....	\$6 00	24 Inch.....	\$13 50
14 ".....	7 50	26 ".....	16 00
16 ".....	9 50	28 ".....	18 50
18 ".....	10 50	30 ".....	19 50
22 ".....	11 75	36 ".....	27 00

A Full Line of these Signs now on hand and for Sale by

R. & L. FRIEDLANDER,

65 & 67 Nassau St., N. Y. City.

GROUT'S EXCELSIOR CARVED IRON OCTAGON SPECTACLE SIGN

Carved in the Most Beautiful Manner and Finished with Best XX Gold Leaf.

Everyone



Warranted.

SIZES

And PRICES

18 Inches, Glass Panels.....	\$2 50	48 Inches, Glass Panels.....	\$9 00
24 " " " ".....	4 00	60 " " " ".....	13 00
36 " " " ".....	6 75	EXCELSIOR SIGN CO., CHICAGO.	

GROUT'S EXCELSIOR IRON NOSE GLASS SIGN,

Gilded with the

GLASS PANELS.

Best XX Gold Leaf.

EXCELSIOR SIGN CO.,

CHICAGO.

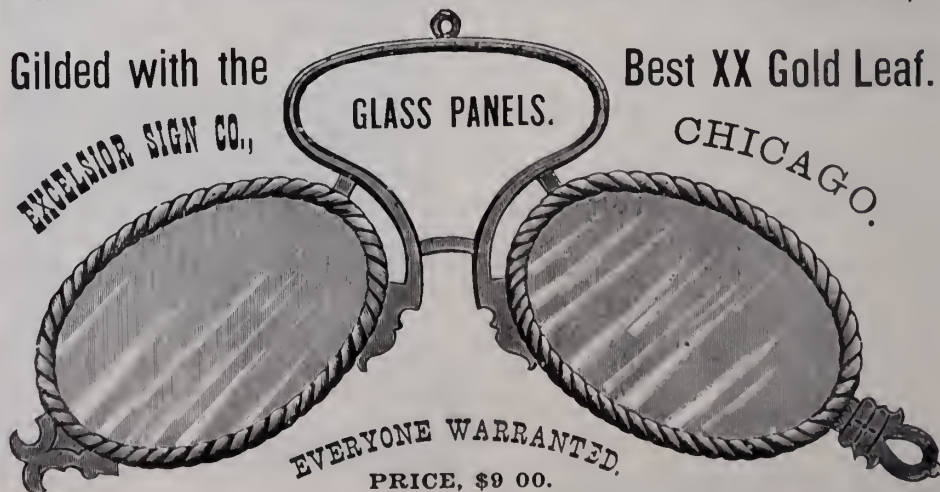

EVERYONE WARRANTED.
PRICE, \$9 00.

"THE SARATOGA."—Patented.

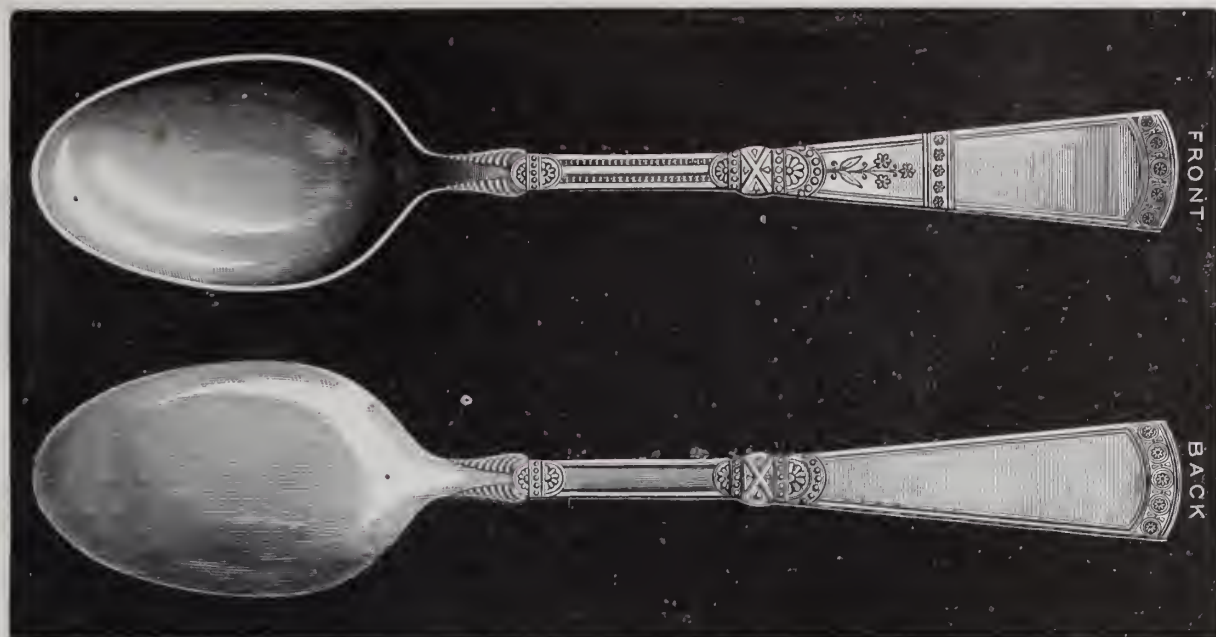

—: MADE BY :—

ROGERS & BROTHER,

690 BROADWAY,

NEW YORK.

WORKS, WATERBURY, CONN.

FIRE! FIRE!

We respectfully notify the Trade that there will be no further interruption to our business, consequent upon the fire in our Ware-rooms last week, as we are disposing of all stock which was in the least damaged, at extremely low cash prices, only to buyers who can inspect the stock while in the city.

All Mail Orders will be filled from **FRESH STOCK OF GOODS.**

NICHOLAS MULLER'S SONS,

MANUFACTURERS OF

CLOCKS AND BRONZES,

117 CHAMBERS ST., NEW YORK.

LOUIS STRASBURGER & CO.

DIRECT IMPORTERS OF

WATCHES AND DIAMONDS,

WE MAKE EVERY KIND
OF WATCH IN
OUR OWN
FACTORY.

WE GET THE ROUGH
DIRECT AND CUT
OUR OWN
GOODS.

No. 15 MAIDEN LANE,

→ NEW YORK ←

Rue Leopold Robert,
CHAUX-DE-FONDS.



Boulevard Haussman, 30,
PARIS.

SPRING SEASON, 1883.

NEW DESIGNS NOW READY.

MIDDLETOWN



PLATE CO.

MANUFACTURERS OF

Superior Silver-Plated Ware.

In Tea Sets, Waiters, Berry Dishes, Baskets, Toilet Sets, Jewel Boxes, Presentation Goods, Epergnes, &c., of the Very Best Quality. Also Pitchers, Pitcher Sets, Swing Sets, Etc.

EVERY VARIETY OF HOLLOW AND FLAT WARE.



OFFICES.

*Middletown, Conn.,
120 Sutter Street, San Francisco, Cal.*

*13 John Street, New York,
101 & 103 State Street, Chicago, Illinois.*

Illustrated Catalogues and Photograph Albums sent to responsible Dealers.

JOSEPH FAHYS & CO.,
 MANUFACTURERS OF
 WATCH CASES,
 38 MAIDEN LANE,

78 Monroe Street, Chicago.

NEW YORK.

Attention is directed to the increased facilities introduced in our Factories for the manufacture of Watch Cases, and the superior class of goods we are now making. It is not too much to say that we are now producing the largest and most complete line of Silver Watch Cases in the country, and that for style, quality, workmanship and finish are not excelled by any other makers.



All cases of our manufacture are stamped with a fac-simile of this Trade Mark.

These goods are offered at a much lower price than any other cases sold in this market.

New styles and designs constantly appearing.

A Full Line of Cases always in Stock.

JOSEPH FAHYS & CO.,
 38 MAIDEN LANE, N. Y.

FOR SALE BY ALL THE LEADING JOBBERS IN THE COUNTRY.

—:o T H E o:—

BROOKLYN :: WATCH :: CASE :: CO.'S EAGLE CASE.

The name was first used by this company seven years ago, to designate a case that was full 8-k. in all its parts, no piece, bearing, or joint, being used that was not full 8-k., or that would not stand the test of pure Nitric Acid without showing green. The Backs and Cap are absolutely free from solder, excepting what holds the joints. This Case has gradually won its way in the Trade, until its Standard of Quality is admitted to be just as reliable as that of gold dollars. To those who are disposed to investigate, it can be shown that no gold of less standard than 12-k. can compare at all favorably with the wearing properties of the

→* "B. W. C. CO.'S EAGLE CASE," *←

and cases can be shown that have been in use since 1875, which compare favorably with 14-k.: it is the Best Case ever offered the Trade for the money. All of these goods are stamped in the Cap with the trade mark (B. W. C. Co.) of the Company.

Any 8-k. red or yellow gold, except our Eagle quality, will not stand the acid test, and when kept in safe or show case will soon discolor, and when carried in the pocket will turn black.

This Company always has in stock the largest assortment in 18-k., 14-k., and Eagle Cases, of the latest designs and most desirable styles.

FOR SALE BY ALL THE PRINCIPAL JOBBERS.

DAVID F. CONOVER & CO.

(SUCCESSORS TO WM. B. WARNE & Co.)

Manufacturers and Wholesale Dealers in

WATCHES and JEWELRY.

Wholesale Agents For

Rogers & Brother's Flat and Hollow Ware



Celluloid Eye-Glasses.

And Sole Agents for the

Patent Railroad Train Watch Chains, Nickel.

WHOLESALE AGENTS FOR

T. A. WILLSON & CO.'S Optical Goods.

Would invite attention to the following new grades of Steel Spectacles lately introduced in the market.

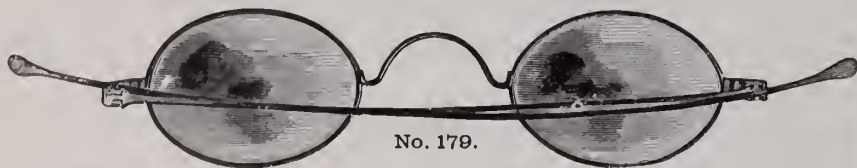

No. 179.

They are Steel, Full Tempered. Parts Interchangeable. Joints so constructed that wear is compensated for. Temple will not work loose and fall down as in old style joints. Nose-piece on No. 155 reinforced where it joins eye, giving extra strength with neatness.

PRIZE MEDALS AT ALL EXHIBITIONS WHERE EXHIBITED.

Patented July 31, 1877.

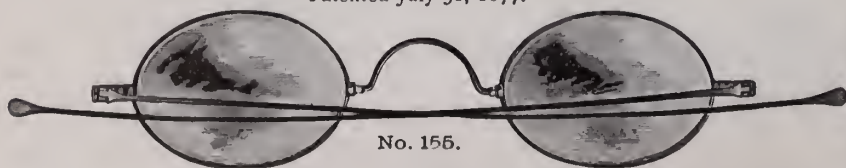

No. 155.

A SPECTACLE TEMPLE

THAT WILL

NOT WEAR LOOSE.

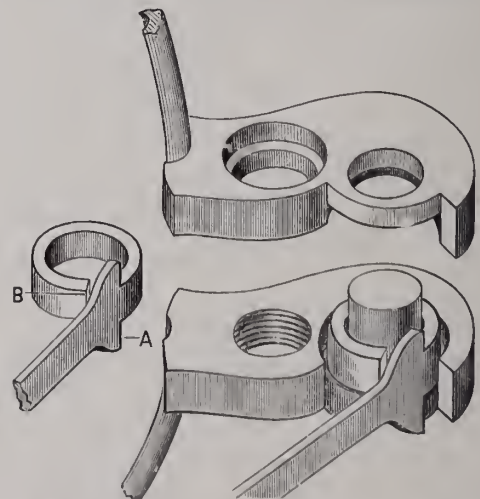

Patented May 13th, 1879. Re-issued June 8th, 1880.

- A.**—Stop for Temple, preventing Strain on Joint.
B.—Compensating eye, for taking up wear of joint. The eye of Temple is smaller than Stubb Steel Joint Pin on which it works, and is left open at **B**, exerting a Spring Tension on Pin.

American Watch Wholesale Salesroom:

Southeast Cor. Chestnut and Seventh Sts., First Floor,

PHILADELPHIA.

DAVID F. CONOVER.
 C. FRANK WILLIAMS
 B. EDGAR RIGHTER.

OPPENHEIMER BROS. & VEITH, WATCHES, DIAMONDS, JEWELRY.

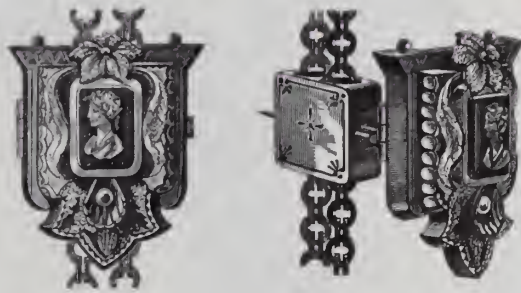

We are the Manufacturers and Patentees of the Combination Slide, Pendant and Locket, and the Combination Necklace, Lace Pin and Pendant.



We can furnish quite a variety of Styles, and are prepared to fill all Orders at once.

35 MAIDEN LANE, NEW YORK.

THE BEST THE DUEBER



WATCH CASE

A WATCH CASE

As Good and as Perfect as

THE DUEBER WATCH CASE

Must be made in the same identical way we make them.



The Duerber Watch Case Manufacturing Co.,

NEW YORK

CINCINNATI

CHICAGO

HOLMES, BOOTH & HAYDENS,

MANUFACTURERS OF

Electro-Silver Plated Spoons, Forks, Ladles, Fancy Pieces, Solid Handle Table Knives, Etc.,

OF THE FINEST QUALITY.

No. 49 CHAMBERS ST.,
NEW YORK.

No. 506 COMMERCE ST.,
PHILADELPHIA.
WORKS AT WATERBURY, CONN.

No. 18 FEDERAL ST.,
BOSTON.

The "Corona" Pattern.
NEW.

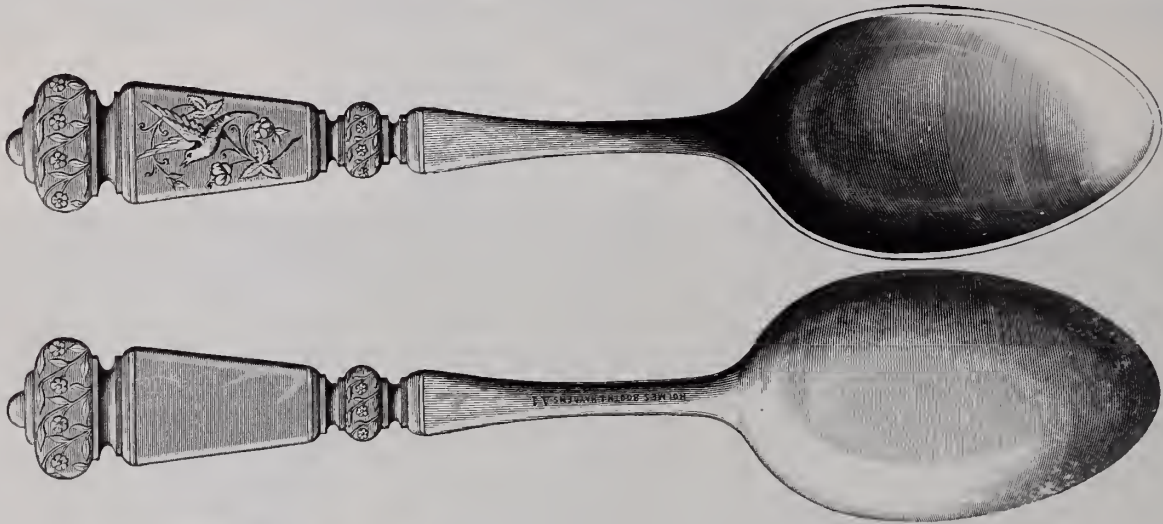

The "Corona" Pattern.
NEW.

The "Japanese" Pattern.



The "Japanese" Pattern.

The "India" Pattern.



The "India" Pattern.

WE GUARANTEE OUR GOODS TO BE FIRST-CLASS IN EVERY RESPECT.

REMOVAL.

On or about April 1st, from

No. 1 JOHN ST., to

No. 18 JOHN ST.,

NEW YORK.

LERROY W. FAIRCHILD.

MANUFACTURER OF

Gold Pens,

Pen and Pencil Cases, Tooth

Picks, Charms, Whistles, &c., in

Solid Gold, Gold and Platinum, Sterling

Silver, Fine Rolled Gold Plate, Etc., Etc.

CHARLES GLATZ,

MANUFACTURER OF

GOLD & SILVER WATCH CASES

WARRANTED

COIN



A SPECIALTY OF FULL WARRANTED 8 KARAT GOLD CASES,

Made in a Larger Variety than any other house, and Workmanship fully equal to the best in the Market.

JOBBER IN ALL AMERICAN MOVEMENTS.

We Call the Attention of the Trade to the Line of LOUIS XIV. Cases, in Gold and Silver, which we have Constantly on Hand.

10 MAIDEN LANE, N. Y. CITY.

EXCLUSIVELY FOR THE JOBBING TRADE.

TAYLOR & BROTHER,
676 BROADWAY, NEW YORK.
 IMPORTERS OF
Diamonds and other Precious Stones,
Clocks, Bronzes and Fancy Goods,
 AND
 MANUFACTURERS OF DIAMOND JEWELRY.



*Especial attention is directed to our Recent Invoices of FRENCH CLOCKS,
 Sold at EXTREMELY LOW PRICES.*

ORIGINAL PACKAGES OF DIAMONDS CONSTANTLY ARRIVING.

SIMPSON, HALL, MILLER & CO.,

WALLINGFORD, CONN.

MANUFACTURERS OF

ARTISTIC & USEFUL HOLLOW WARE,

→: ELECTRO PLATED UPON FINE HARD WHITE METAL. ←:



Spoons, Forks, etc., plated upon the Finest Nickel Silver in **Extra Double, Triple, and Sectional Plates.** Full lines of over **Forty Staple and Fancy Pieces** in each Pattern in Geneva, St. James, Countess, Windsor, Oval Thread, etc. Made under the supervision, and quality guaranteed and controlled by Wm. Rogers, formerly of Hartford and Meriden. (Wm. Rogers, Sr., died 1873).

WM. ROGERS, Wallingford, Conn.

No connection with any concern in Waterbury, Meriden or Hartford using name of Rogers in any form.

Store and Stock of Goods for Delivery in N. Y. and Vicinity,
No. 36 East Fourteenth Street, Union Square.

Philadelphia, 506 Commerce St.—San Francisco, Cal., 530 Market St.
Montreal, Canada.—Baltimore, 6 German St.

JOBBER IN CINCINNATI, CHICAGO, ST. LOUIS, Etc.

BROWN & BROTHERS,

Finest Silver Plated Flat Ware,

SPRING TEMPERED SHANK. NEW AND CHOICE PATTERNS.



“FLORAL.”

We guarantee all our goods to be made of full quality 18 per cent. Nickel Silver, and weight of plate to be as indicated on the labels.

GOODS PACKED ONE DOZEN IN EACH BOX.

Factories, Waterbury, Conn.

Salesroom, 80 & 82 Chambers Street, N. Y.

THE DERBY SILVER COMPANY, Birmingham, Conn.,

MAKERS OF THE
BEST QUADRUPLE



Illustrated Catalogues sent to Dealers upon Application.

ADOLPH GOLDSMITH,

SOLE AGENT FOR THE

RELIANCE WATCH COMPANY,

38 MAIDEN LANE,

NEW YORK.

FULL LINE OF

Gold and Plated Jewelry.

EVERY DESCRIPTION OF

SWISS WATCHES

A SPECIALTY.

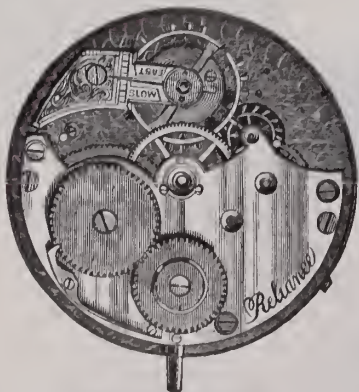

"RELIANCE,"
18 Size, to Fit Waltham Cases.



"RELIANCE,"
Nickel Stem Winder in all Sizes.



"RELIANCE,"
Ladies' 8 Size, to Fit Waltham Cases.

The American Lever,

THE FAULTLESS CUFF AND COLLAR BUTTON,
HAS BEEN SINCE ITS FIRST INTRODUCTION, AND WILL ALWAYS REMAIN

COCK OF THE WALK!



ASK YOUR JOBBER FOR THE MOST SALABLE BUTTON IN THE MARKET, AND IF HE IS NOT INTERESTED IN PUSHING THE SALE OF AN INFERIOR ARTICLE,

☞ HE WILL RECOMMEND **THE AMERICAN LEVER,** ☞
EVERY TIME!

ESTABLISHED 1847.

J. T. SCOTT & CO.,

IMPORTERS, JOBBERS & MANUFACTURERS,
No. 7 MAIDEN LANE, N. Y.

Would Respectfully Announce to the Trade that they this season offer a

LARGE AND ATTRACTIVE STOCK OF DESIRABLE JEWELRY,
of the latest and newest designs, and suitable to the requirements of all classes of
dealers. Our Stock embraces a Full Line of

Lace Pins, Ear Rings, Rings, Bracelets, Bangles, Gold and Plated Chain,
in fact, everything in the Jewelry line. Also Sole Importers of the celebrated

TRIUMPH-ROSKOPF WATCH,

universally acknowledged by Competent Workmen to be *the best Watch for the
money made.*



WITH INTERCHANGEABLE
AND ADJUSTABLE
ESCAPEMENT.

Cased in Superior Nickel, Open
Faces, Stem Wind and Set.

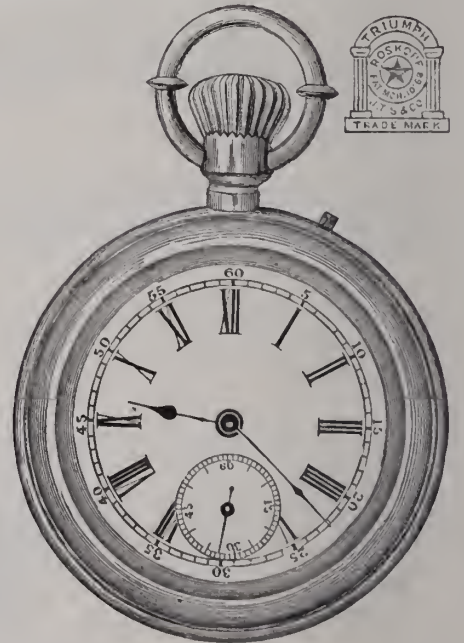
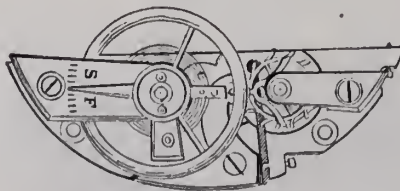

SOLE AGENTS OF THE OLD RELIABLE PATENT ROSKOPF WATCH.



A Full Line of American Movements and Cases.

All Orders committed to our care will Receive Prompt and Careful Attention.



Manufactory, 47, 49 & 51 Franklin Street, Newark, N. J.

MILLER BROS., JEWELERS,

7 MAIDEN LANE, NEW YORK.

SETS,
EAR RINGS,
CROSSES,
LOCKETS,
LACE PINS,
MEDALLIONS,

MOUNTED WITH

STUDS,
SCARF PINS,
COLLAR BUTTONS,
SCARF RINGS,
SLEEVE BUTTONS,
Etc., Etc., Etc.

Diamonds, Rubies, Sapphires, Pearls, Turquoise, Birds, Animal Heads and Fancy Ornamentations.

INITIAL GOODS A SPECIALTY.

All goods exclusively of our own manufacture, many of which are protected by MECHANICAL and DESIGN PATENTS.

CROSS & BEGUELIN,

21 MAIDEN LANE, N. Y.

P. O. BOX No. 531.

MANUFACTURERS OF THE CENTENNIAL

CHRONOGRAPH

THE BEST AND CHEAPEST HORSE TIMER

AND THE

Most Accurate Time Keeper in the World for the Money.

IN GOLD AND SILVER CASES.

CHEAP AND RELIABLE.

See Cut. THE EXACT SIZE.



WHOLESALE DEALERS IN ALL GRADES OF

AMERICAN AND SWISS WATCHES, JEWELRY, MATERIALS, ETC.

SOLE AGENTS IN NEW YORK FOR THE SALE OF THE ENGLE ENGRAVING MACHINE.

WM. SMITH & CO.,

MANUFACTURERS OF

GOLD and SILVER Chains & Jewelry,

Also a Large Line of SILVER RINGS.

OFFICE :

No. 25 Maiden Lane, New York.

MANUFACTORY—No 61 PECK STREET, PROVIDENCE, R. I.

W. & S. BLACKINTON,

MANUFACTURERS OF

ONLY

FINE ROLLED PLATE CHAINS,

Necklaces, Polished and Roman, of Latest Gold Designs. Also a Complete Line of Gents' and Ladies' Locketts and Pendants.

In consequence of the first-class reputation our goods have obtained, unscrupulous dealers have been selling goods of an inferior quality, represented as our manufacture. In order to protect ourselves, as well as dealers, all goods of our manufacture will hereafter bear this

TRADE MARK. **W&S B** ★ TRADE MARK.

These Goods are for sale by all Wholesale Dealers.

ESTABLISHED 1873.

DIAMOND JEWELRY.

CHAS. P. HEROLD,

916 CHESTNUT STREET,

PHILADELPHIA,

(SECOND FLOOR).

Manufacturer of

18 K.

DIAMOND

MOUNTINGS

A SPECIALTY.

And Exclusively of my own Designs.

ESTABLISHED 1833.

FOR THE SPRING TRADE.

E. IRA RICHARDS & CO.,

MANUFACTURERS (Exclusively) OF

FINE ROLLED PLATED JEWELRY.

The Largest and Choicest Stock in the Country.

SPECIALTY FOR THE COMING SPRING,

BAND & BANGLE BRACELETS & Extra Quality ROLLED PLATED CHAINS.

These Vest Chains are produced to meet the demand for a

ROLLED PLATED CHAIN

that will wear for years. Each Chain bears the initial letters of our firm.

**No. 200 BROADWAY, NEW YORK.
2d STORY, FRONT.**

GOODS SENT ON SELECTION TO RESPONSIBLE PARTIES.

CHESTER MANCHESTER & CO.,

MANUFACTURERS OF

Gold & Silver Chains,

No. 13 HANOVER STREET,

PROVIDENCE, R. I.

Waltham, Elgin, Illinois,
Hampden, E. Howard & Co.
and Special Movements.

**392 WASHINGTON ST.,
BOSTON.**

P. O. Box 5259.

D. C. PERCIVAL & CO., WHOLESALE DEALERS.

Watches, Jewelry,
Gold Chains, Gold,
Filled and Silver Cases,
Spectacles, Eye Glasses,
Gold Head Canes, and Rogers &
Bro.'s Flat Ware.

Price List of Movements and Cases
Sent on Receipt of Business Card.

ESTABLISHED 1837.

VICTOR BISHOP & CO.

IMPORTERS OF

DIAMONDS,

**Rubies, Sapphires,
Emeralds & Pearls.**

Enamel Paintings, Roman Pearls,
Copper, Platinum and Iridium.

33 MAIDEN LANE, NEW YORK.

House in Paris, 66 Boulevard de Sebastopol.

LOUIS A. SCHERR & CO.

Importers and Wholesale Dealers in

Watches, Jewelry,

WATCH MATERIALS, TOOLS, GLASSES, &c.

Spectacles, Silk Guards, &c.

Wholesale Agents for American Watches.

**No. 726 CHESTNUT STREET
PHILADELPHIA.**

AGENTS FOR THE WHITCOMB LATHE

AGENTS FOR W. F. NYE'S WATCH AND CLOCK OILS.

TO THE TRADE.

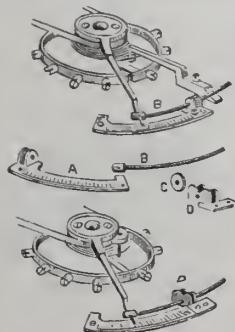

Your attention is called to the Improved Awalt Patent Watch Regulator, Style B. It is made of Nickel, Index and all combined, with Nut C and Screw B made of Fine Steel, to fit all full plate watches, by removing the Index and using the same screw holes and screws on the watch.

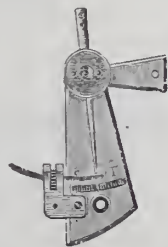

Style D Regulators have been improved in shape and finish, and fit both full plate and bridge watches, are made in Gilt and Nickel, with Nut C and Screw B of Fine Steel. Try them, and it will surprise you to find how much they will aid in making a watch realize you a nice profit.

JOHN A. AWALT, Manufacturer,

ALSO JOBBER IN

WATCHES, CLOCKS, JEWELRY, Etc.,

177 Vine Street,

CINCINNATI, OHIO.

LORD & CO.

MANUFACTURERS OF

FINE JEWELRY,

No. 44 HILL STREET,

NEWARK,

NEW JERSEY.

JOHN W. STEELE,

MANUFACTURER OF

FINE GOLD JEWELRY,

—AND—

BRAINERD'S

PATENT

LOCKETS

Patented June 17, 1874.



No. 9 Maiden Lane, NEW YORK.

MATERIALS
AND
OPTICAL GOODS.

Agents for the

LANCASTER, PA., WATCHES.

A. FRIEDENTHAL & CO.

Manufacturing Jewelers,

AND IMPORTERS OF

WATCHES,

43 MAIDEN LANE, NEW YORK.

THE BEST.
CELLULOID SHOW CASES.

REQUIRE NO CLEANING.

POLISH PERMANENT.

Send for Circular with Description, References, Testimonials,
 and List of Manufacturers.

CELLULOID SHOW CASE CO.,
 17 Maiden Lane, N. Y.

DAY & CLARK,
 —: MAKERS OF :—
FINE ROMAN GOODS,
BANGLES,
Plain and Ornamented Bead Necklaces.
 Every style & size of Diamond Ear Ring Covers,
LACE PINS AND EAR DROPS.
STONE SEALS AND LOCKETS.
192 Broadway, cor. John Street,
FACTORY, NEWARK, N. J. NEW YORK.

ESTABLISHED 1858.

WELCH & MILLER,

Jewelry Case Manufacturers,

OF MOROCCO, VELVET, RUSSIA, BROCADE AND PLUSH.
 TRAYS OF ALL DESCRIPTIONS.
 TELESCOPE SAMPLE CASES with FLEXIBLE TRAYS.

Agents for Jewelers' Cotton and Twine.
 A LARGE STOCK ALWAYS ON HAND.

169 BROADWAY, NEW YORK.

SUSSFELD, LORSCH & NORDLINGER,
 IMPORTERS OF
Optical & Mathematical Instruments,
Watchmakers' Tools, Materials, Etc.

SPECIALTIES:

BARDOU & SONS' Universal Opera Glasses U. S. Army and Navy Glasses,
 Rifle Range Telescopes, Etc., Etc.

LA REINE Opera and Marine Glasses.

CROWN Spectacles and Eye-Glasses.

PARADIS MAINSPRINGS.

PARAGON TOOLS.

13 MAIDEN LANE, NEW YORK.

16 Rue D'Enghien, PARIS.

JAMES W. TODD,
 SUCCESSOR TO GEO. W. PLATT,
 →* Wholesale Dealer in *←
WATCHES & JEWELRY,
GOLD AND SILVER SPECTACLES
And Eye-Glasses,
No. 6 LIBERTY PLACE,
NEW YORK.

DORRANCE, EDGE & CO.,

Sole Manufacturers of the Celebrated

Woven Fabric Gold Chain,

Elegantly Mounted Bracelets, OPERA, LEONTINE.

VICTORIA WATCH GUARDS AND NECKLACES
 In all the Newest Designs.

Our Stock is unusually complete, and in addition to the above a
 variety of NECKLACES, from 1½ to 40 dwts. each, to
 which we invite the attention of buyers.

CHILDREN'S BRACELETS A SPECIALTY.

No. 15 JOHN ST., NEW YORK.

FACTORY, 46 GREENE ST., NEWARK, N. J.

HELLER & BARDEL,

MANUFACTURERS OF

DIAMOND AND PEARL JEWELRY,

No. 13 John Street, New York.

A Novelty which we have introduced this season is

The Combination Ring, Lace Pin and Bracelet.

The advantages of this article of Jewelry will be readily appreciated, when taken into consideration that **One Piece of Jewelry** can be worn in three different forms.

R. WALLACE & SONS M'FG CO.,

MANUFACTURERS OF

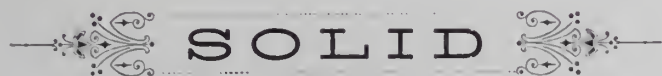

SILVERWARE,

GUARANTEED $\frac{925}{1000}$ FINE.

WALLINGFORD, CONN.

H. P. HILDRETH,

MANUFACTURER OF

SOLID GOLD RINGS,

PLAIN AND ORNAMENTAL,

10 JOHN STREET, NEW YORK.

Factory, 1305 ATLANTIC AVENUE, Brooklyn.

Best Quality of Goods at Lowest Cash Prices.

Send for Price List, as I have no Agents.

COX & SEDGWICK,

26 JOHN STREET, N. Y.,

Makers of Patent Black Onyx Bracelets

Also Black Onyx Faceted Bead Bracelets,
AT THE LOWEST PRICES.

COLORED

AND

Turquoise

Lace Pins,
Ear Rings,
Lockets,
Bracelets,
Sleeve
Buttons,
Scarf Pins,

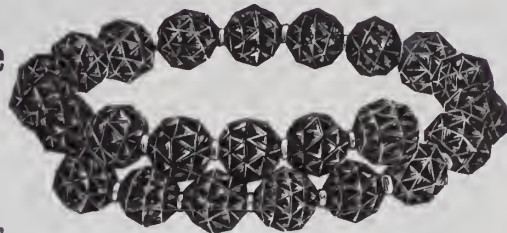

ONYX

Lace Pins,
Ear Rings,
Medallions,
Necklaces,
Chatelaines
Sleeve Buttons
Ladies & Gents
Vest and
Guard Chain.

Black Onyx Pins, Ear Rings and Lockets for 1, 3 and 5 Diamonds.

☞ GOODS SENT ON APPROVAL TO RESPONSIBLE FIRMS. ☞

WOOD & HUGHES,

STERLING

SILVERWARE MANUFACTURERS,

New York Agents for the Derby Silver Co.'s

Fine Quadruple Plated Ware,

No. 16 John Street, N. Y.

206 Kearney Street, San Francisco, Cal.

HASKELL & MUEGGE, Agents.

J. B. & S. M. KNOWLES,

MANUFACTURERS OF

Sterling Silver Ware,

No. 20 MAIDEN LANE,

NEW YORK.

FACTORY, PROVIDENCE, R. I.

GORHAM M'FG CO.
SILVERSMITHS **37 UNION SQUARE,**
NEW YORK.



STERLING SILVER TEA SERVICE



MAKERS
 GORHAM M'FG CO SILVERSMITHS
 PROVIDENCE & NEW YORK.

Small, faint text at the bottom right corner, possibly a date or reference number.

ALFRED H. SMITH & CO.
IMPORTERS OF

DIAMONDS



182 BROADWAY
COR OF JOHNST.

NEW YORK

No 125 STATE STREET · 33 HOLBORN VIADUCT.

·CHICAGO·

·LONDON·

S. J. COX SC. DEL. N. Y.

THE

NEW HAVEN CLOCK CO.

MANUFACTURERS,

IMPORTERS,

DEALERS.



FACTORIES.
NEW HAVEN, CONN.

GENERAL OFFICE AND SALESROOMS.
62 READE STREET,
New York.

WESTERN OFFICE AND SALESROOMS.
31 WASHINGTON ST.,
Chicago, Ill.

EUROPEAN OFFICE AND SALESROOMS.
16 PITT STREET,
Cleveland Sq., Liverpool,
England.

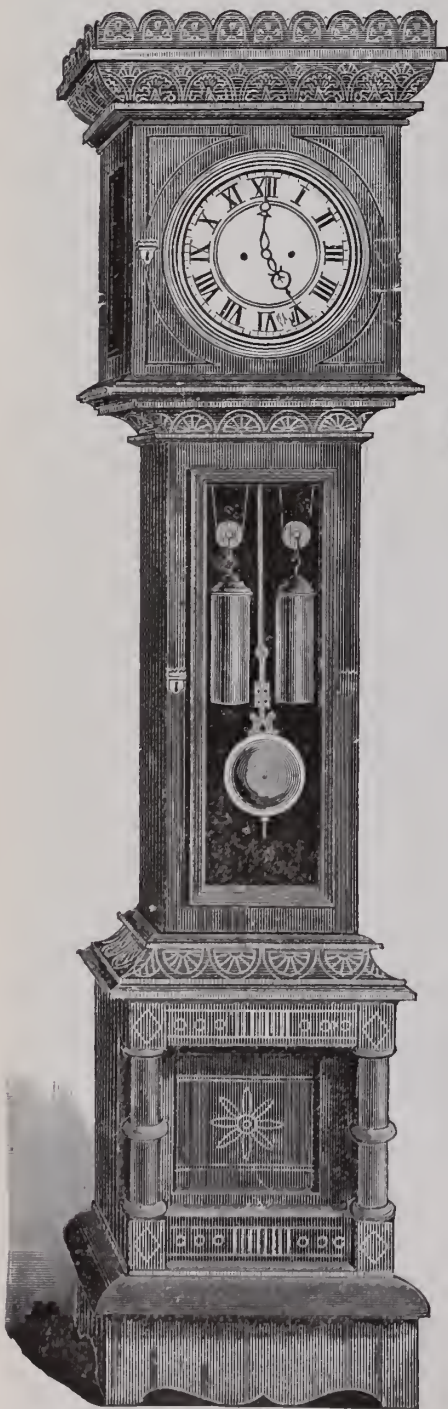

CARVED WOOD,
English Regulator.

WE have again introduced many Popular Improvements as well as New Designs, combining the most desirable effects and thorough construction with moderate prices. Among these will be found our new 8-day Pendulum Movements, striking hours and half hours on Gong Bells with Cathedral tones. By this means we bring within the reach of all the best selling points of the most expensive imported clocks.

We also call attention to the fact that we sell these Cathedral Gongs either separately or fitted in any of our Visible Pendulum Clocks at a moderate extra charge.

We now have the greatest facilities for

IMPORTING

all kinds of

French Clocks

and

BRONZES,

and are pleased to ask our patrons to give this fact their careful attention and allow us, by a trial, to show them that we can offer a better and cheaper assortment than any other house.

Send for Complete Catalogue of All Styles.



No. 1035.

MARBLE,
Imported.

FRIED & BARTON, *Makers* Manufacturers of Fine Silver Plated Table Ware,

Factories, TAUNTON, MASS.

Salesrooms, 686 BROADWAY, N. Y.



WATER SET No. 1933, - - - -

PRICE, \$62.00.



CARTER, SLOAN & CO.,
 MANUFACTURERS OF ALL KINDS OF
GOLD JEWELRY,
 BROADWAY AND FOURTH STREET,
 NEW YORK.
 A. CARTER, JR.
 A. K. SLOAN,
 C. E. HASTINGS,
 G. R. HOWE.

BALDWIN, SEXTON & PETERSON,
 IMPORTERS OF
DIAMONDS and all **PRECIOUS STONES,**
 MANUFACTURERS OF
 DIAMOND AND RICH JEWELRY.
 Cutters and Polishers of
DIAMONDS
 692 & 694 BROADWAY, NEW YORK.
 120 SUTTER ST., SAN FRANCISCO, CAL.

J. F. Chatellier,
 Manufacturing Jeweler,
 692 & 694 Broadway,
 New York.



TRADE MARK.
 STERLING.
Whiting Manufacturing Co.
 SILVERSMITHS,
 BROADWAY & FOURTH ST., N. Y.

ESTABLISHED 1837.
TAYLOR & BROTHER,
 Old House READ, TAYLOR & CO.,
Importers of Diamonds and Pearls,
 —)AND(—
 MANUFACTURERS OF DIAMOND JEWELRY,
 21 Holborn Viaduct, 676 Broadway,
 LONDON. NEW YORK.

ESTABLISHED 1813.
THOMAS G. BROWN & SONS,
 Newark, N. J., & 5 Bond Street, New York.
 MANUFACTURERS OF
ARTISTIC JEWELRY
 FOR PRESENTATION,
 Including Prizes for **ROWING, RIFLE SHOOTING, ARCHERY** and
 all **ATHLETIC SPORTS.**
 COLLEGE SOCIETY PINS AND CLASS RINGS, ALSO BADGES FOR MILITARY
 AND CIVIC BODIES IN ALL METALS.
 Employing able Designers, and having all work, both in Designing and Manu-
 facturing, done in our own factory, we can submit, for the inspection of those
 interested, entirely original designs, appropriate in style, and not to be seen else-
 where.
 Estimates and Designs will be sent to Reputable Dealers when desired.

ESTABLISHED 1834.

G. & S. OWEN & CO.,

—MAKERS OF—

FINE ROMAN JEWELRY, &c—

—&c— BOX and GLASS PINS,

—AND—

Black Onyx and Pearl Goods,

OF EVERY DESCRIPTION.

All Goods sold by us are exclusively of our own manufacture and are warranted 14 K. Fine, and stamped as such when possible.

No. 3 Maiden Lane, New York.

W. H. SHEAFER & Co.,

MAKERS OF

BRACELETS,

BANGLES,

LACE PINS,

SCARF PINS, ETC.

No. 15 JOHN STREET,

NEW YORK.

RIPLEY HOWLAND M'F'G CO.,

MAKERS OF

FINE JEWELRY,

SPECIALTIES:

DIAMOND MOUNTINGS, with Platinum Tips.

ENGRAVED RINGS, STONE RINGS,

OFFICE, 17 MAIDEN LANE,
NEW YORK.

FACTORY, 383 WASHINGTON ST.,
BOSTON, MASS.

SAXTON, SMITH & CO.,

Manufacturers of

GOLD CHAIN

SOLE AGENTS

FOR THE

NEW PATENTED CHAIN BAR,

Containing a Detachable Pencil.

FACTORY:
183 EDDY ST.,
PROVIDENCE, R. I.

OFFICE:
14 JOHN ST.,
NEW YORK.

A. J. HEDGES & CO.,

MANUFACTURING

JEWELERS,

No. 6 MAIDEN LANE,

NEW YORK.

Factory, No. 90 MECHANIC ST.,

NEWARK, N. J.

A. W. FABER'S

CELEBRATED

Gold Pens & Pencil Cases.

TOOTH PICKS AND NOVELTIES.

Manufactured by

EBERHARD FABER,

Nos. 718 and 720 Broadway,
NEW YORK.

J. B. BOWDEN & CO.,

MANUFACTURERS OF

SOLID RINGS

Of Every Description.

No. 1 MAIDEN LANE,

Cor. Broadway,

NEW YORK.

MOORE & HORTON,

No. 11 Maiden Lane,

NEW YORK.

JEWELERS

SPECIALTIES:

Stone Cameo, Onyx, Amethyst, Topaz and Pearl Rings.

Studs, Collar and Sleeve Buttons.

Also our fac-simile of Fine African Diamonds, with Foile Back, Mounted in Rings, Studs, Pins, Ear Rings, Scarf Pins, Lace Pins, &c.

JOHN F. SAUNDERS,
Of the late firm of Buckenham, Cole & Saunders.

CHAUNCEY IVES.

SAUNDERS & IVES,
IMPORTERS OF

DIAMONDS, PEARLS,
And Other Precious Stones.

Manufacturers of Diamond Mountings.
No. 26 MAIDEN LANE, NEW YORK.

A Large Stock of FINE DIAMONDS, Mounted and Unmounted, kept constantly on hand.

Goods sent on approval to any part of the country on receipt of satisfactory reference. All our goods ARE INSURED by us while in transit.

CHAMPENOIS & CO,

No. 5 MAIDEN LANE, NEW YORK.

Manufacturers of Solid Gold Jewelry,
AND THE

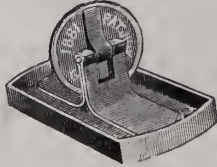
"BEST  LEVER"

SLEEVE AND COLLAR BUTTON.

Also Sets, Ear Knobs, Bracelets, Studs, Lace and Cuff Pins, Onyx and Jet Cluster Goods.

Specialty:—Engraved and Enameled Goods.

G. W. PRATT & Co.,

Manufacturers and Dealers in

Watches and Jewelry

OF EVERY DESCRIPTION.

ELGIN AND ILLINOIS MOVEMENTS
IN ALL GRADES.

Gold, Silver and Ladd Patent Cases.

No. 14 JOHN STREET, NEW YORK.

C. ROSSWOG & SON,

MANUFACTURERS OF

Rich Jewelry and Diamond Goods,

NOS. 5 & 7 MAIDEN LANE,

NEW YORK.

CHAS. F. TERHUNE & CO.,
Rolled Plate Chains and Gold and Plated Jewelry,

MANUFACTURING JEWELERS.

Terhune's Patent Slide Buttons.



194 Broadway,



NEW YORK.

S. W. HALE & CO.,

SUCCESSORS TO HALE & MULFORD,

MANUFACTURERS OF

FINE JEWELRY

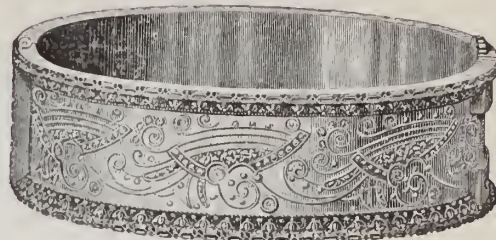

692 BROADWAY, N. Y.

SETH W. HALE.

WILLIAM A. LEE.

WILLIS H. HOWES.

JULIEN CALLET & CO.,
IMPORTERS OF

WATCHES

OF EVERY GRADE,

No. 1 MAIDEN LANE,

NEW YORK.

SPECIAL NOTICE.

Office of **JOHN T. MAURAN,**

Manufacturing Jeweler,
15 MAIDEN LANE.

New York, February 1st, 1883.
The business of Manufacturing Jewelry, founded by the late John T. Mauran, will be continued without change by the undersigned, retaining the old office at No. 15 Maiden Lane, New York.

Thanking you for your generous favors of the past, we hope, by keeping the stock up to its old standard of quality and excellence, and by continued addition of **New Designs**, to merit a continuance of your patronage.

H. C. CRANSTON,

Administrator and Representative of the Heirs.

SMITH & KNAPP,

WHOLESALE DEALERS IN

AMERICAN AND SWISS WATCHES,

DIAMONDS.

Gold & Plated Pencils and Gold Chain,

No. 182 BROADWAY,

COR. OF JOHN STREET,

NEW YORK.

OFFICE:
14 JOHN STREET, N. Y.

E. STITES' SONS.

FACTORY:
NEWARK, NEW JERSEY.

TRAITEL BROTHERS,

40 Maiden Lane, New York.

MAKERS OF

STANDARD QUALITIES

T X B

10-k.

TRADE MARKS.

T 14 K B

14-k.

SOLID GOLD RINGS.

Ask your Jobber for our Standard Qualities.

ESTABLISHED 1867.

F. JEANDHEUR, Jr.,

125 FULTON STREET, N. Y.

Gold and Silver Electro-Plating.

Mr. Jeandheur begs to notify the Trade that he has made more improvements with his new process of Electro-Plating Watches, Jewelry, Etc. By having introduced an Electro-Plating Machine instead of using the old method of plating with Chemical Battery, he is able to plate with a far greater depth of gold than before, and for wear it is equal to rolled plate. The Trade can rely on this statement, as a trial will abundantly prove, and his well-earned reputation amongst the leading houses in the Trade will be sustained.

P. S.—He also begs to notify the Trade that he has no connection with any other house or person using his name, for the purpose of soliciting work.

PRICE LISTS SENT UPON APPLICATION.

Webster's Silver Solution,

PREPARED BY

E. G. WEBSTER & BROTHER,

(Established 1859.)

Manufacturers of Quadruple

Electro Silver Plated Ware

14 MAIDEN LANE, N. Y.,

Expressly for Cleaning Silver and Silver Plated Ware.

Jewelers will find this a valuable adjunct for cleaning their stock, and a reliable article to recommend to their customers.

Guaranteed entirely free from Cyanide, Acid, Grit, or anything detrimental to the Finest Wares.

Packed in Boxes containing 2 Doz. Bottles.

Price, \$1.25 per Doz., NET.



PEARCE & HOAGLAND,

MANUFACTURERS OF

Gold Pens, Pencils, Pen Holders, Tooth Picks,

OF EVERY DESCRIPTION.



CLOSED

SOLE MANUFACTURERS OF THE

QUILL RESERVE TOOTH PICK,



OPEN



CLOSED

The Holder of this Case is made in various styles in Gold Plate, Celluloid, Ivory, etc., while the Pick is of ordinary Goose Quill, and can be easily replaced by a new one, at any time, from the Reserve in the end of the Holder, and is the only Pick that will not injure the Teeth.

FOR SALE BY ALL JOBBERS.

Office and Factory, 29 Point Street, Providence, R. I.

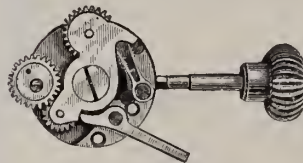

For AMERICAN
18 Size Watches.

ABBOTT'S
PATENTS.

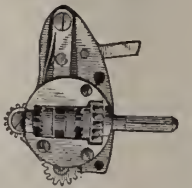

For HOWARD
16 & 18 Size Watches.

HENRY ABBOTT,

7 MAIDEN LANE,

NEW YORK.

MANUFACTURER

FOR SALE BY JOBBERS.

Patented November 18, 1873.

MORRISON'S

Gold & Silver Solutions

For Electro-Plating Without a Battery.

Invaluable for Watchmakers and Jewelers. So simple that any one can use them.

Price, Gold Solution, - - \$3.00 Silver Solution, - - \$1.50

MANUFACTURED BY

ARTHUR B. MORRISON, Portland, Maine.

FOR SALE BY

Sussfeld, Lorsch & Co., New York; Henry Ginnel, New York; Cross & Beguelin, New York; Kearney & Swartchild, Chicago, Ill.; Louis A. Scherr & Co., Philadelphia, Pa.; Duhme & Co., Cincinnati, O.; Harwood Bros., A. Paul & Co., Palmer, Bachelder & Co. Boston, Mass., and material dealers generally.

BEWARE OF BASE IMITATIONS put up by unprincipled persons. None are genuine without the Trade Mark which consists of the letters A. B. M. in monogram and fac simile of Medal awarded by U. S. Centennial Commission.

MANUFACTURERS
OF
Everything in
BLACK ONYX JEWELRY
PLAIN, and {Ornamented with
 { Pearls and
 { Diamonds.

Our manufacturing facilities have been for the past ten years devoted exclusively to the production of fine Black Onyx Jewelry. We carry in stock the largest variety of articles made in our specialty, well made, finely finished, uniformly 14 karats, at medium and low prices.

WOGLOM & MILLER,
Office & Factory, 32 & 34 JOHN STREET,
NEW YORK.

TO LET.

Floors 45x90 with Power, in New Building, cor. of York and Washington Streets, Brooklyn. Suitable for Jewelers and Silversmiths. Light on all sides. Conveniences for Burning and Grinding Sweeps. A night watchman in building. Location near terminus of bridge.

KETCHAM & McDOUGALL,

4 LIBERTY PLACE, N. Y.

MANUFACTURERS OF

GOLD AND SILVER THIMBLES,

And the Automatic Eye-Glass Holder.

Flexible Bracelets,
Diamond Mountings,
Strung Pearl Work,
Repairing,

Flexible Braided
Bracelets,
White Stone Goods,
Strung Pearl Repairing

Thos. M. Guilbert & Co.,

SUCCESSORS TO CARROW, DUBOSQ & Co.

908 Chestnut Street, Philadelphia, Pa

B. A. BALLOU & CO.,

61 Peck St., Providence, R. I.

MANUFACTURERS OF

GOLD JEWELRY.



We call special attention to our PATENT FASTENING FOR EAR RINGS, which is free from the objections raised to ordinary ear wire or screw fastenings. They present a very neat and attractive appearance, are perfectly secure, and much more convenient than ordinary ear wires which always annoy the wearer by catching the hair, veil, or lace about the neck. These Goods are for Sale by all Wholesale Dealers.

Gold Studs, Small Chains for Eye-Glasses, Bracelets, Etc. a Specialty.



Wm. C. GREENE & Co.
GOLDSMITHS.

MANUFACTURERS OF

RICH SETS IN TAPER WIRE CORAL

Factory 95 PINE ST. Providence, R. I.

Stone-Cameo
Amethyst
Coral Cameo
Engraved
Enamel Sets
Sleeve Buttons
Stud Buttons
EAR DROPS
& C. New York Office
192 BROADWAY.

WM. C. GREENE. B. W. GREENE. GEO. D. BIGGS.

ESTABLISHED 1859.

STURDY BROS. & CO.

MANUFACTURERS OF

Fine Rolled Plate Jewelry,

GRADUATED WIRE CORAL GOODS,
STERLING SILVER JEWELRY.

- Bangles,
- Sleeve Buttons,
- Cuff Buttons,
- Baby Pins,
- Sets in Stone, Cameo, Enamel, Chased, and Polished.
- Drops and Knobs,
- Bar Pins,
- Children's Sets,
- Locketts,
- Studs,
- Charms,
- Etc.

Only Wholesale Dealers' Trade Solicited. ATTLEBORO, MASS.

JAMES J. FISHER,

DEALER IN

WATCHMAKERS' and JEWELERS' MATERIALS,

Files, Tools, Silk Guards, Watch Glasses, Spectacles, Rolled Plate, Fire Gilt, Nickel and Silver Chain, Charms, &c.

No. 697 BROADWAY,

Corner Fourth Street, NEW YORK.

All kinds of Job Work for the Trade Promptly attended to.

The "Acme" French Clock Movement Support.

(Pat. Nov. 1st, 1881.)

This Support is adapted to the holding in position of any French Clock Movement while regulating or adjusting, and will be found very desirable on account of its simplicity of action and the small space it occupies. To be had of any respectable jobbing house, or sent, post paid, to any address, on receipt of 60 cents.



McCarty & Hurlburt,

WHOLESALE DEALERS IN

WALTHAM, ELGIN & ILLINOIS

WATCHES.

MANUFACTURERS OF

Jewelry, Gold Spectacles, Silver Thimbles, &c

131 North Second St.,

PHILADELPHIA, Pa.

C
L
O
C
K
S

ESTABLISHED 1853.



AMERICAN

AND

FRENCH CLOCKS

AND

BRONZES.

B. J. COOKE'S SONS,137 N. 3d Street, PHILADELPHIA.
Catalogues and Price Lists furnished to the Trade only, on application.**BOOZ & CO.,**

MANUFACTURERS OF

FINE GOLD

AND

PLAIN GOLD

Watch Cases  RINGS.

Jobbers in American Movements.

DIAMONDS.

108 South Eighth St., (2d Story) Philadelphia.

Samples of our goods sent on approval when satisfactory reference is furnished.
Old Gold and Silver Bought or Exchanged.

PARTICULAR ATTENTION PAID TO REPAIRING.

The ORIGINAL GOLD CROWN
FILLED RINGS.

For the past thirteen years we have manufactured as a specialty, the well known "CROWN GOLD FILLED RING," with the high standing of which the trade is already perfectly familiar. In consequence of the above fact, and in justice to ourselves, we feel it a duty to make the announcement to the trade that there are now being offered in the market several other makes of filled rings, each of which has a CROWN in some way connected with its STAMP.

We Manufacture for the Jobbing Trade Only.

McCALL & NEWMAN,
625 Arch Street, Philadelphia**O. W. BULLOCK,**

SPRINGFIELD, MASS.,

MANUFACTURER OF

FINE NICKEL PLATED WATCH & JEWELING TOOLS,

Watch Keys and Light Metallic Goods.

SEND FOR NEW ILLUSTRATED CATALOGUE AND PRICE LIST.

BLANCARD & OBERLANDER,

MANUFACTURERS OF

Settings and Galleries,

IN THE LATEST STYLE.

BALL WIRE, Solid and Hollow, in 14 and 10 karat, also single Hollow Balls without joint, of all sizes, in Silver and 14 karat alloy and upwards.
Made in any thickness of Gold to order.

Platinum, Platinum-Lined and Fancy Settings a Specialty.

PLATINUM SCRAPS EXCHANGED OR PURCHASED.

36 & 38 JOHN STREET, N. Y.

PLEASE SEND FOR SAMPLE CARD.

Established 1848.

HENRY HARRISON,

66 NASSAU ST., NEW YORK,

MANUFACTURER OF

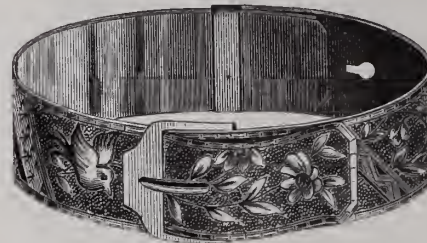
**Gold Bangles,
Bangle Rings,**

AND

Gold Flat Band and Buckle

BRACELETS,

Both Engraved and Enameled.

ALSO DEALER IN WATCHES AND JEWELRY.

IMPORTER OF THE BEST G. S. CHAIN.

B. W. KOOPMAN,

MANUFACTURER AND PATENTEE OF THE CELEBRATED

AUTOMATIC FIRE LIGHTING CLOCK.

The Ninth Wonder of the World.

Already Introduced on both sides of the OCEAN.

*Sample of our New Style of Clock
sent to Jewelers at a Reduced Price.*For Circular, containing full particulars,
with Terms to Dealers, Address**KOOPMAN'S PATENT CLOCK WORKS,** Terre Haute, Ind.

Refer to any Commercial Agency in U. S.

William T. Smith,
ASSAYER, REFINER AND SWEEP SMELTER.

ESTABLISHED IN 1855.

Cor. Blackstone & Hawkins Sts

PROVIDENCE, R. I.

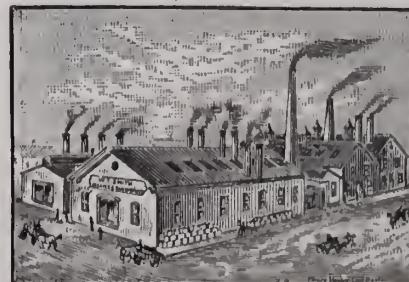

PROVIDENCE, R. I., Feb. 1st, 1881.

To whom it may Concern :

We take pleasure in recommending Mr. WM. T. SMITH. He has done the whole of our Refining ever since he has been in business, and we have ever found him prompt in making returns, and always to our satisfaction.

D. WILCOX & CO.

JEWELRY AND WATCHES.

ROGERS' SILVERWARE.

MATERIALS AND TOOLS.

S. F. MYERS & CO.,
Manufacturers and Jobbers,
179 BROADWAY, NEW YORK.

ILLUSTRATED CATALOGUE FOR THE TRADE.

W. E. WHITE & CO.,
Manufacturing Jewelers.



FINE
**ROLLED PLATE
GOODS.**

Bracelets---Engraved, Enamelled, Flat Band and Buckle.

Ladies' Goods—Lace Pins, Drops, Crosses, Sets, Collar Buttons, &c.

FOR SALE BY JOBBERS ONLY.

New York Office, 26 MAIDEN LANE, Corner Nassau Street.

Factory 54 Page St., Providence, R. I.

Represented by S. A. BALDWIN.

ALEX. MILNE,
Manufacturer of Stem-Winding Watch Crowns



ALSO COLD AND SILVER THIMBLES.



19 Ward Street, NEWARK, N. J.

PFORZHEIMER, KELLER & CO.

MANUFACTURERS OF

FINE JEWELRY,

AND DEALERS IN

American and Swiss Watches,

No. 24 JOHN STREET,

I. PFORZHEIMER,
D. KELLER.

NEW YORK.

I. B. ETINGER,
H. J. FINK.

Henry Ford,

Importer of Rough & Polished Diamonds.

DIAMOND CUTTING AND POLISHING WORKS:

21, 23, 25 Looijersgracht,



4 & 6 JOHN ST.,

Amsterdam, Holland.

New York.

Diamonds repaired and matched by some of the finest workmen in the world.

Diamond Bort and Powder always on hand.

ESTABLISHED 1850.

TRADE



MARK

PETER L. KRIDER,
MANUFACTURER OF
STERLING SILVERWARE

Medal and Diploma Awarded. &c. Striking Society
Medals in Gold, Silver or Bronze a Specialty.

Artisan Hall, 618 Chestnut St., Philadelphia.



KING JAMES,
MARQUIS, } RINGS.
GLOVE, }

Quality Guaranteed.
Prices Close.

BARNET BROS. & POWELL,

—Manufacturers,—

Newark, N. J., & 15 JOHN ST., NEW YORK.

R. & K.'S PATENT GAS FURNACES FOR MELTING, PLATING,
ENAMELING, ANNEALING, &c., &c.

Reichhelm & Koester,

Importers and Manufacturers of

Jewelers' Tools, Files, Materials, &c.,

Manufacturers of
Bristle Brushes of all kinds,
Cotton and Wool Buffs,
Felt Polishing Wheels,
Walrus Leather Polishing
Wheels,
Jewelers' Satin Finish and
Scratch Brushes,
Brass & Steel Wire Brushes
Jewelers' Standard Saw
Frames,
Plain & Fancy Draw Plates,
Improved Jewelers' Ingots,
R. & K.'s Jewelers' Combi-
nation Gas Burners.

80 Nassau St.

NEW YORK.

Importers of
French, English & German
Tools and Files,
Piercing Saws,
Renard & Vautier Gravers,
Steel and Brass Wires,
Vienna and Ruby Draw
Plates,
Alloying Copper Wire,
Felt, Walrus Leather,
Vienna Lime, Tripoli,
&c., &c., &c.

Send for Illustrated Catalogue.

WILLIAM S. HICKS
MANUFACTURER OF
GOLD PENS & PENCIL CASES.
KNOWN AND SOLD IN BOTH HEMISPHERES AS

ESTABLISHED 1848.

Office and Factory: **No. 20 Maiden Lane, New York.**
BR. OFFICE, No. 8 Snow Hill, London.

"STANDARD" GOODS FOR OVER THIRTY YEARS.

JOSEPH STERN. JACOB STERN. SIMON STERN.

STERN & STERN,
Wholesale Dealers in
WATCHES & DIAMONDS
And Manufacturers of
GOLD JEWELRY,
6 MAIDEN LANE, NEW YORK.

AGENTS FOR THE CELEBRATED
MELVILLE & NEW BRIGHTON WATCHES.

TRIER BROTHERS,
IMPORTERS,

15 MAIDEN LANE, NEW YORK.

SPECIALTIES:

Bohemian Garnet, Whitby Jet, Steel and Amber Jewelry, Opera, Marine and Field Glasses, Telescopes, Pearl Card Cases, Silk Guards, Etc.

Also a Complete Line of
GOLD AND GOLD PLATED JEWELRY.

GEO. W. DUBOIS.

F. N. NAUMAN.

GEO. W. DUBOIS & CO.,

IMPORTERS OF

Watches & Optical Goods.

ALL STYLES AND QUALITIES OF
SPECTACLES AND EYE-GLASSES.

LONGINES' WATCHES AND MOVEMENTS.

The Watches in Gold, Silver and Nickel Cases of New and Handsome Patterns. The Movements fit 18 size Waltham Stem Winding Hunting Cases.

36 MAIDEN LANE, NEW YORK.

Orders by Mail Receive Prompt Attention.

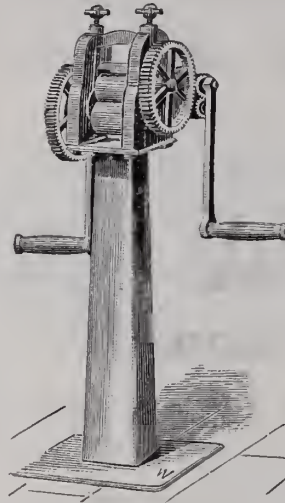

W. W. OLIVER,

MANUFACTURER OF

Hand and Power
Rolling Mills,

For Jewelers and Silversmiths.

The "Little Giant" Ring Bender

Hollow Spindle Lathes, Punching and Dro Presses, Polishing Heads, Dies, Metal Laps, Etc.

39 CLINTON STREET,

BUFFALO, NEW YORK.

Illustrated Price List mailed free upon application.

NEW YORK DIAL COMPANY,

HENRY ABBOTT,

SOLE AGENT,

NO. 7 MAIDEN LANE, NEW YORK.

MANUFACTURERS OF

Fine GLASS ENAMEL DIALS for WATCHES.

S. KOHN & CO.,

15 JOHN ST.,

NEW YORK.

Manufacturers of
Fine Morocco, Plush and
Velvet Boxes.



Trays and Silverware
Boxes of all Description
Made to Order.

A Full Line of Boxes Constantly on Hand, and Samples sent on Selection.

ORDERS FROM THE JOBBING TRADE RESPECTFULLY SOLICITED.

WHEELER, PARSONS & HAYES,
 MANUFACTURERS OF
WATCH CASES, GOLD CHAINS & FINE JEWELRY

Importers of Diamonds and Manufacturers of Diamond Jewelry,
And Dealers in American and Swiss Watches,
No. 2 MAIDEN LANE, NEW YORK.

Established 1841.

Enos Richardson & Co.,
 Manufacturers of Gold Jewelry and Chains,
 23 Maiden Lane, New York.

Goods sent on approval to Dealers in any part of the U. S. upon receipt of order with satisfactory references.

San Francisco Office, 206 Kearny St., Haskell & Muegge, Agents,
 Where a full line of our goods can always be found at Eastern Prices.

Established 1828.

JACOB BENNETT & SON,
 Diamond Setters and Manufacturing Jewelers,
 No. 923 CHESTNUT STREET, PHILADELPHIA.

WE MANUFACTURE AND MAKE A SPECIALTY OF
 EVERY DESCRIPTION OF

DIAMOND MOUNTINGS,

SUPERIOR IN DESIGN AND WORKMANSHIP.



Dealers in

DIAMONDS

And all kinds of Precious Stones.

Of which we keep a Large Assortment Constantly on Hand.

Masonic Marks Society and School Badges, Made to Order Only. Designs and Estimates Furnished.
 PARTICULAR ATTENTION GIVEN TO ALL KINDS OF JOBBING.

EDWIN A. THRALL,

1 MAIDEN LANE,

NEW YORK.

—• JOBBER IN —•

American Watches, Diamonds, Fine Jewelry, Etc.

AT LOW PRICES, AND FOR CASH ONLY.

I employ no Travelers, therefore can furnish select goods of the newest designs at the very lowest market price. Every Watch warranted to keep time when delivered. The new system introduced by the American Watch Co., of selling a complete watch, will be adopted. Agent for the new Mascot Bracelet, Patented. Orders filled immediately on receipt. Repairing and Adjusting Fine Watches and Chronometers for the Trade a Specialty.

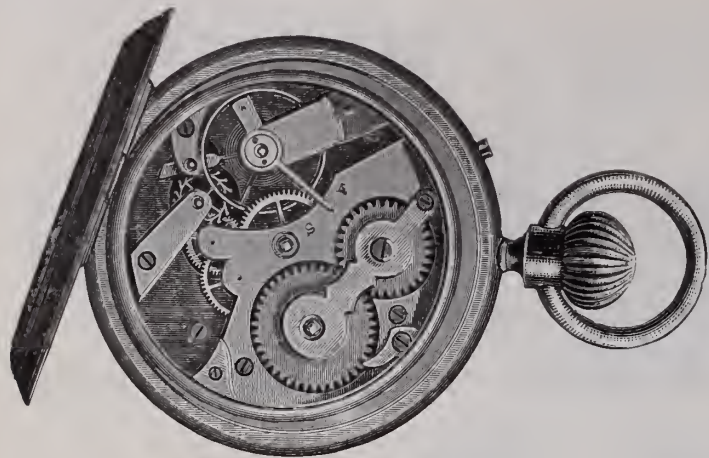

ESTABLISHED 1839.

HENRY GINNEL,

31 Maiden Lane, N.Y.

SOLE IMPORTER OF THE

PIONEER WATCHAcknowledged by the Trade to be the best Watch for the money
in the world.

They are for Sale by all the leading Houses throughout the land.

A. J. WARNER & CO., WHOLESALE JEWELERS,

309 Nicollet Avenue, Minneapolis, Minn.

We carry a Large and Elegant Stock of Jewelry, Watches, Cases, Etc., Etc.
North-western Agents of the WATERBURY CLOCK CO., and carry a Complete
Line of their Goods.

OUR TRADE IS EXCLUSIVELY WITH THE JEWELERS.

WASHBURN'S

SHUT OPEN

SAFETY CATCH, Pat. Sept. 20, '81, Jan. 10, '82.

PATENTS

Safety Ear Fastening No. 1.

Patented May 10, 1881.

Jointed Ear Wire and Bar between Cramp of Setting.
Patented March 10, 1881.

Safety Ear Fastening No. 2.

Patented October 11, 1881.

Descriptive Circulars
FURNISHED,
ON APPLICATION.

ADOPTED AND IN USE BY
RANDEL, BAREMORE & BILLINGS,
DIAMONDS,
58 NASSAU STREET,
NEW YORK.

Address or Apply to
GEO. W. WASHBURN
58 NASSAU ST.,
NEW YORK.

N. H. WHITE,

JOBBER IN

AMERICAN-WALTHAM WATCHES, EXCLUSIVELY.

Waltham make of gold-and silver cases a Specialty. Ladd, Boss, and the Patent Screw Bezel Filled Cases to fit Waltham movements only
No. 11 MAIDEN LANE, NEW YORK.

I not only advertise that I have the Waltham Goods, but **have constantly on hand** the Largest Stock carried by any jobber
in the trade. Gold Cases of all Weights and Styles. Memorandum Packages with pleasure to dealers furnishing satisfactory reference.

COMPLETE PRICE LIST TO THE TRADE.

W.M. S. HEDGES & CO.,

IMPORTERS OF



COPYRIGHT SECURED.

Entered According to Act of Congress in the year 1880, by W.M. S. HEDGES & Co., in the Office of the Librarian of Congress, at Washington.

No. 170 BROADWAY,

Corner Maiden Lane, New York.

Choice Brilliants in Single Stones and Matched Pairs a Specialty.

Fresh invoices of Goods in all Grades constantly arriving. Also choice parcels of exceptionally Fine Gems Especially selected for critical purchasers. A full line of Mounted Goods Artistically Designed.

GOODS SENT ON APPROVAL.

—+—+ NEW +—+—

CHRONOGRAPH

STOP WATCHES,

—+—+ MADE TO +—+—

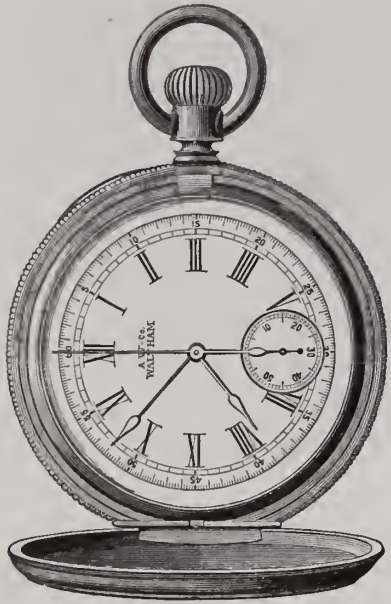

START, STOP AND FLY BACK,

With or Without Split Seconds,

MANUFACTURED BY THE

AMERICAN WATCH CO.,

WALTHAM, MASS.



By Patented Improvements in Construction, and considerable Diminution of the Parts required, as well as by the application of American Machinery, the AMERICAN WATCH CO. has so simplified the manufacture of Chronograph Watches as to greatly reduce their cost. They can now be obtained at prices which make them the MOST DESIRABLE timepieces for Sporting Purposes, AS WELL AS FOR GENERAL USE. Dealers can depend upon these goods giving satisfaction, as they will not require the constant repairs, nor subject the dealer to the annoyance experienced in most of the foreign watches of this class. In case of accidents, Duplicates of Broken Parts can be furnished by return mail. Cased complete in 16 Size Gold and Silver Open Face and Hunting Cases. (Open Face made to wind at figure XII).

SPECIAL NET PRICE LIST,

Issued for the TRADE ONLY, will be sent on application, which will not be regarded unless accompanied by Business Card.

ANNOUNCEMENT.

The New Price List for complete 3-4 plate, 8, 14 and 16-size Gold Watches, issued under date of February 1st, 1883, by the American Watch Co., of Waltham, is now ready for distribution. We will forward a copy upon application, accompanied by business card, from any regular dealer in watches.

Jobbers who wish copies sent to their customers will please notify us by sending the names and addresses of the same, but such customers must be regular Watch Dealers. We shall take special precaution in the distribution of this list, in order to keep it out of the hands of the general public, and we beg to request that the Trade will co-operate with us in this undertaking, it being entirely in their interests.

We also beg to call particular attention to the fact that the cases quoted in this list are entirely of our own manufacture, and that we are directly responsible for the quality of the same.

By 18 K. or 14 K. or 10 K. we mean 18 K. or 14 K. or 10 K., and not 16½ K. or 12 K. or 8 K. We offer you actual value for your money.

ROBBINS & APPLETON,

NEW YORK:

5 BOND STREET.

BOSTON, MASS.:

403 WASHINGTON STREET.

CHICAGO, ILL.:

170 STATE STREET.

LONDON, ENGLAND:

HOLBORN CIRCUS.

AUSTRALIA:

SYDNEY, NEW SOUTH WALES.



Randel, Baremore & Billings,

Importers of

Diamonds

and Manufacturers of

Diamond Jewelry.

*58 Nassau Street,
8 29 Maiden Lane,
New York.*

*1 St. Andrews Street,
Holborn Circus,
London, E. C.*

THE
"POTTER WATCH."

ALBERT H. POTTER & CO.,
7 RUE DU MONT BLANC,
GENEVA.

BURGER & CO.,
12 JOHN STREET,
NEW YORK.



SINNOCK & SHERRILL,
THE LARGEST MANUFACTURERS OF SEAL AND STONE RINGS
(Making that a Specialty and Manufacturing Nothing Else.)
IN THE UNITED STATES.

The first and most important thing to be looked after in buying Rings is the **Quality**. If that is not as represented, customers are lost, and much trouble may follow.

Dealers buying our Rings, will find each one which is sold for 14 K. stamped $\frac{584}{1000}$ fine, or when there is not room for that, 14 K. fine or 14 K., but never 14 alone, and all are guaranteed to assay $\frac{584}{1000}$ fine, which is a fraction over 14 K. by a United States Assay.

The second most important thing is the **Design**. If the design is inappropriate or ungainly, the sale of the Ring cannot be effected, no matter how fine the quality; and thirdly, perfection must be sought after in the **Finish** of the Ring.

If the stone is wrongly or unevenly set, if the shank is imperfectly soldered, badly engraved or poorly polished, the quality goes for nothing, the beauty of the design is lost and the Ring cannot be sold. Combining the most complete machinery with the best skilled labor, our customers will find the three above objects sought after by us and **GENERALLY** attained.

New York Office, No. 3 MAIDEN LANE.

Factory, NEWARK, N. J.

Western Office, CHICAGO, ILLS.

→ † M. FOX & CO., † ←

Practical Lapidaries and Importers of

D I A M O N D S .

Rubies, Sapphires and Fancy Gems.

→ † PEARLS, † † TURQUOISE, † † INTAGLIOS, † † ONYX, † † AMETHYST, † † ETC. † ←

No. 1 MAIDEN LANE, NEW YORK.

LEON JEANNE.

PAUL JEANNE

JEANNE BROTHERS

MANUFACTURERS OF

DIAMOND MOUNTINGS,

AND RICH JEWELRY.

No. 1 MAIDEN LANE, NEW YORK

Designs Furnished and Estimates Given.

JEANNE BROS PAT. DIAMOND SETTINGS.

A PLATINUM SETTING WITH A GOLD SURFACE OUTSIDE

IN THIS WAY THE REFLECTION OF GOLD THROUGH THE DIAMOND IS ENTIRELY

PAT. AUG. 15TH 1882 **AVOIDED.**

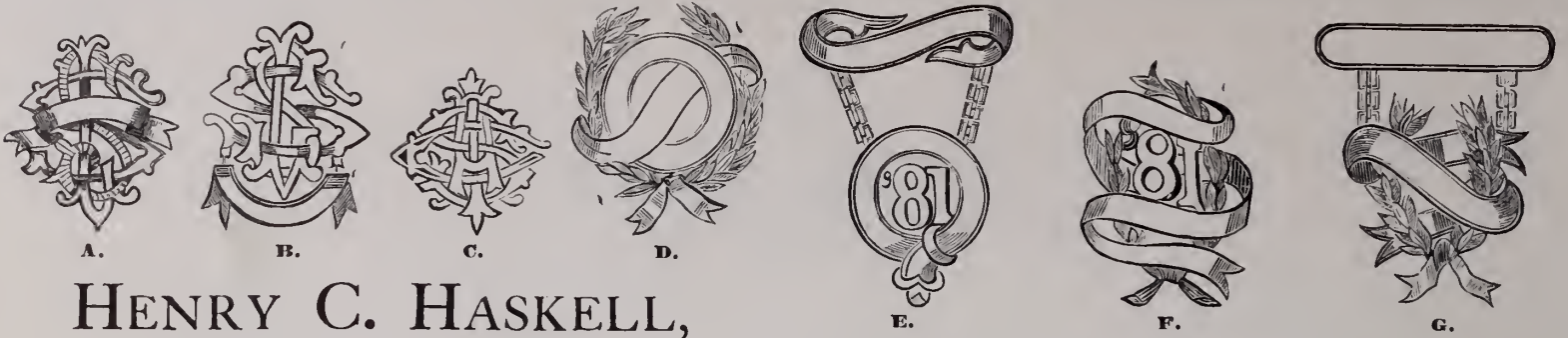

HENRY C. HASKELL,

MAKER OF FINE GOLD JEWELRY.

No. 12 John St., New York.

Goods sent on approval to any part of the country, upon receipt of satisfactory references.

BADGES, CLASS PINS, RINGS, MEDALS,

MADE TO ORDER FROM ORIGINAL DESIGNS.

Illustrated Plates of Designs for Portfolio sent only to Dealers upon request.

House Established 1837,

Successor to J. A. ABRY.

CHARLES LEO ABRY,

Importer and Manufacturer of all Grades of

SWISS WATCHES,

And dealer in Elgin, Springfield, Ill., and Lancaster Movements.

Specialties in Gilt, Nicked and Nickel Stem-Winding Movements, Ladies' Sizes, to Fit Elgin Cases.

IMPORTER OF THE FOLLOWING WELL-KNOWN SWISS WATCHES:

Geo. Mayor, A. Ames Droz, Chas. Estine, F. Richard, Huguenin Nardin and Ernest Duval, as well as all kinds of Watches for the Jobbing Trade, including Nicked, Open-Face and Hunting Stem-Winders, Anchors and Cylinders, 16, 18 and 19 lines. Silver Key and Stem-Winders, Hunting and Open Face, all sizes and qualities, from low to highest grades. Silver and Nickel 13 and 14 line Watches for Chatelaines, Gold, Silver, Nickel & Rolled Plate Chatelaines of good styles & designs always in stock.



COMET.

SOLE IMPORTER.

Fits 8 Size Elgin Cases.

P. O. Box 611.

63 NASSAU STREET, NEW YORK.

Factory, Neuchatel, Switzerland.

JOHN A. RILEY & CO.,

Nos. 7 & 9 BOND STREET,
MANUFACTURERS OF

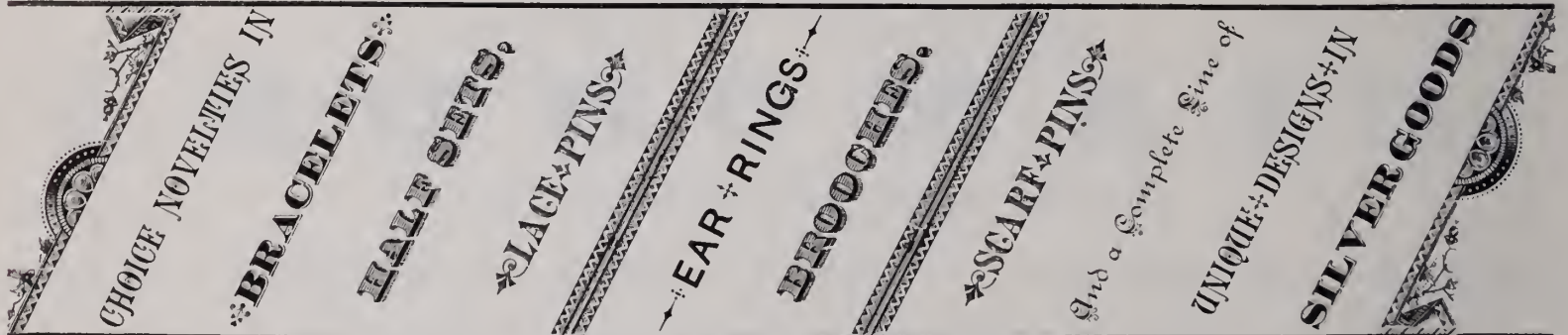

ALL GOLD GOODS ARE OF OUR MANUFACTURE AND 14 K. FINE.

A. BERNHARDT & CO.
MANUFACTURERS OF
DIAMOND & FINE JEWELRY
ORNAMENTAL HAIRWORK
OFFICE & FACTORIES
3, 4, & 5 FLOOR,
P.O. BOX 1111.
MAIDEN LANE,
NEW YORK.

LUDWIG LEHMANN,

MANUFACTURER OF

JEWELERS' FINDINGS,

Paper Jewelry Boxes, Jewelers' Cards, Cotton of all Shades, a Rich Assortment of Cases in Plush, Velvet and Morocco.

Also Importer of the Celebrated Grass Bleached Tissue Paper, Mill 39.

Specialties:—Imitation Morocco Boxes and Cases, Plush and Satin Lined.

122 FULTON STREET, near Nassau, NEW YORK.

TEMPORARILY REMOVED TO 283 PEARL STREET.

HOPKINS' PATENT IMPROVED PIVOTING CHUCK,

WITH PUMP CENTER.

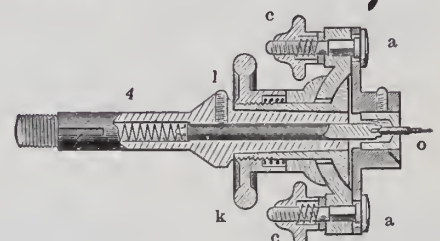
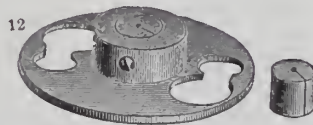
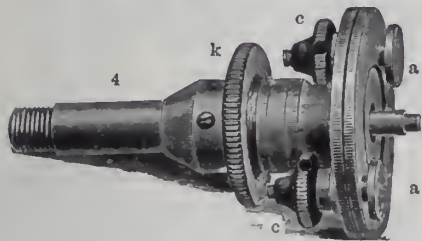

This Chuck, in accuracy of working, exceeds any other Chuck, either adjustable or self-centering, ever made, and is the only Chuck that, without the use of wax, will hold work to as perfect center and line as though held between dead centers.

HOPKINS WATCH TOOL CO.,

WALTHAM, MASS.

Send for full Descriptive Catalogue of our Manufactures.

ESTABLISHED 1810.

VACHERON & CONSTANTIN,

WATCH MANUFACTURERS,

GENEVA,

SWITZERLAND.

These celebrated Watches and Movements are adjusted to Heat, Cold and Position. Movements Fitting ready made Stem-winding, Open Face and Hunting Cases of Waltham and Elgin Sizes.

SOLE AGENT IN UNITED STATES AND CANADA,

CHAS. LEO ABRY,

P. O. BOX 611.

63 NASSAU STREET, NEW YORK.

1883



LUDWIG & NOLTING

Cincinnati's Exclusive Wholesale Jewelers.

New Goods in Novelties and Staple Lines.

LOW PRICES

AND ALL GOODS FULLY WARRANTED.

THEUERNER & CHURCH, MANUFACTURERS OF FINE RINGS, No. 9 MAIDEN LANE,

FACTORY, COR. MULBERRY & DURAND STS., NEWARK, N. J.

NEW YORK.

ESTABLISHED 1859.

RINGS A SPECIALTY.

BRYANT & BENTLEY,

12 MAIDEN LANE,

Up-Stairs,

NEW YORK.

AMONG OUR LATEST PATTERNS OF FINE SOLID RINGS ARE



587



591

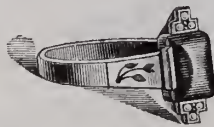

584



504



589



490

No. 587—Made in Topaz and Amethyst. No. 591—Cluster of Garnets, Doublets or Turquoise, with Pearls and Diamonds. No. 584—Cameo or Garnet with Pearls and Diamonds. No. 504—Misses' Turquoise Rings. Nos. 490 and 589—Represent two patterns only of our Engraved Band Rings.

We also continue to make a full line of our well known 16 K. HARD SOLDER RINGS.

Goods sent on approval to responsible parties.

ESTABLISHED 1874.

JOSEPH P. WATHIER,

Successor to JOSEPH P. WATHIER & BRO.,

178 WEST MADISON ST., CHICAGO, ILL.

WHOLESALE JEWELER & WATCHMAKER & JEWELER FOR THE TRADE,

Changing of Key Winding Movements into Stem Winding and Hand Setting,

AND MAKING STEM WINDING PARTS A SPECIALTY.

All Work Intrusted to me will receive PROMPT ATTENTION, and Satisfaction Warranted, at Prices Always the Lowest.

HENRY ZIMMERN,

IMPORTER OF

Watch Materials,

TOOLS,

AND OPTICAL GOODS,

No. 8 Maiden Lane, New York.

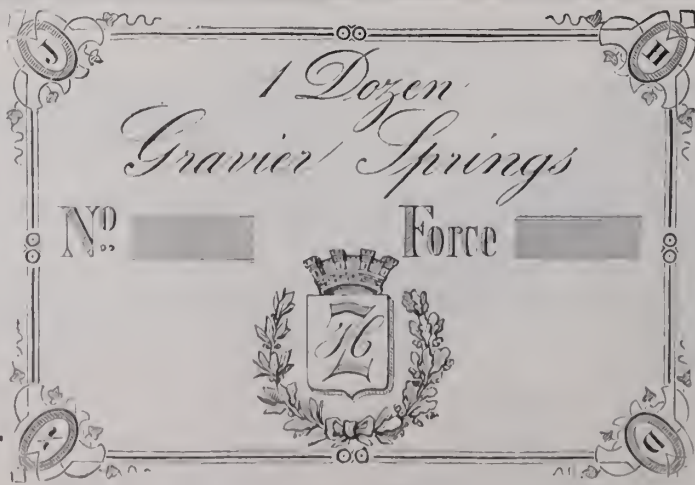

SOLE AGENT
FOR THE CELEBRATED
GRAVIER
MAINSPRINGS.

The cut is a fac simile of trade mark with my monogram on wrapper, adopted by me to prevent the trade from being imposed upon with imitation springs. A brass tag attached to each spring indicates the number and strength according to Dennison's United States Standard Gauge. These Springs are to be obtained at all leading Jobbing Houses.

WHITE METAL CHAINS A SPECIALTY.

E. AUG. NERESHEIMER
& Co

IMPORTERS
of

DIAMONDS

21 MAIDEN
LANE
NEW YORK

NO 66 SARPHATI STRAAT
AMSTERDAM HOLL.

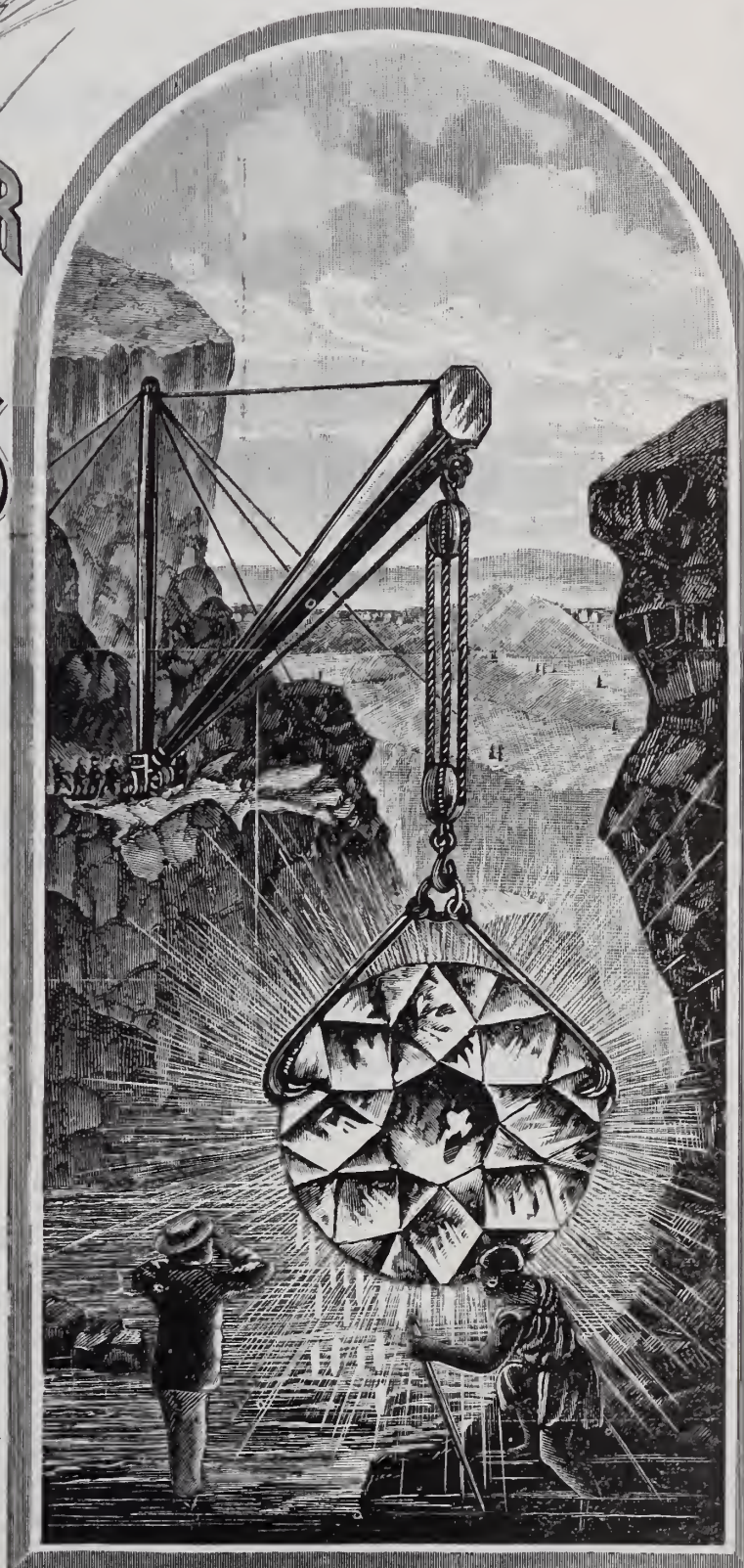

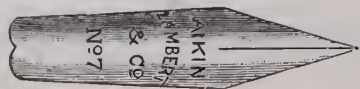

AIKIN, LAMBERT & CO.,

23 MAIDEN LANE, NEW YORK.

MANUFACTURERS OF

GOLD PENS, PENCIL CASES, HOLDERS, PENCILS, TOOTH PICKS

AND LATEST "NOVELTIES" IN PENCIL CHARMS.



NEW GOODS FOR SPRING TRADE.



"GRAVITY" PENCIL.

In addition to our Large Assortment of Gold Pen and Pencil Goods, we offer this season many New and Novel Patterns, all of our *Exclusive* Manufacture and Sale.



Our Line of Richly *Ornamented Engraved* Holders in all styles, suitable for Presentation purposes, show many Patterns *New* to the Trade.



New Styles of Pencil Charms in *Solid* Gold, Silver and Rolled Plate.



Our Line in Tooth Picks embraces the *Latest* Designs in *Solid* Gold, Silver, Pearl, Celluloid (Fancy and Plain) and Plated.

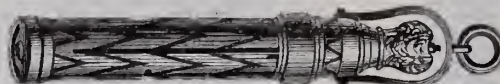

Goods Sent on APPROVAL when desired.

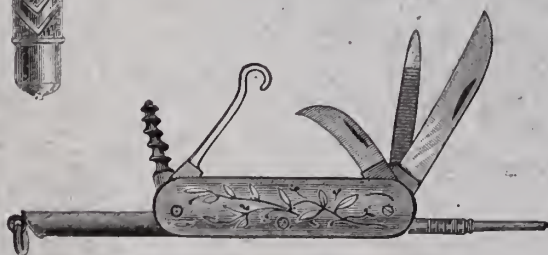

SEND FOR
Catalogue and Price List.



—:o ALSO IMPORTERS AND JOBBERS OF ALL GRADES OF o:—

WATCHES.

Including a Large Variety of *Desirable* Metal Cased Stem-Winders, and the *best* Low-Priced "Chronograph" Watch in the market.

Agents for *AGASSIZ* Movements fitting 8 and 16 Size Elgin Cases, and the *LONGINES* Movements fitting 18 Size Waltham Cases. Sole Agents for *PAUL BRETON* Celebrated Geneva Watches.

Jobbers of all kinds of *AMERICAN MOVEMENTS AND CASES*, including the Ducber and Keystone Silver Cases, and Boss' and Ladd's Filled Cases.

Manufacturers of *STONE RINGS*, all leading kinds, Band Rings, &c. Gold and Silver Thimbles, Plain, Chased, Octagon, &c. Bracelets, a large assortment in Gold and Plate. Gold and Plated Chains, Locketts, Seals, &c. A large variety of new and stylish Patterns in *GOLD* and *PLATED JEWELRY* are constantly being added to our stock. *Prompt attention to Orders and Repairs.*

JAS. C. AIKIN,
H. A. LAMBERT,
J. B. SHEA,
D. F. FOLEY.

Western Branch, 113 EAST MADISON STREET, CHICAGO, ILLS.

Falkenau Oppenheimer & Co.
Importers of
Diamonds

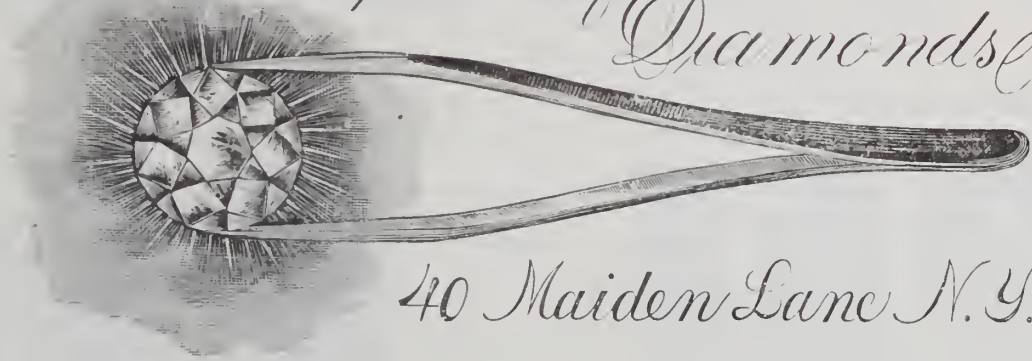

40 Maiden Lane N. Y.

Post Office Box 3314.



Our friends will please notice that we have removed
our Establishment to above address.



SIMONS, BROTHER & CO., Manufacturers.



**F
I
N
E
J
E
W
E
L
R
Y**

ENGRAVED AND ENAMELED.

ENGRAVED AND ENAMELED BUCKLE.

**T
H
I
M
B
L
E
S**



112 3/4 in. 113 5/8 in. 114 1/2 in. 115 3/8 in. 102 3/4 in. 103 5/8 in. 104 1/2 in. 105 3/8 in.

BLACK ENAMEL AND GOLD.

BLACK ENAMELED BUCKLES.



BEST
Bracelets
FOR THE
MONEY MADE.

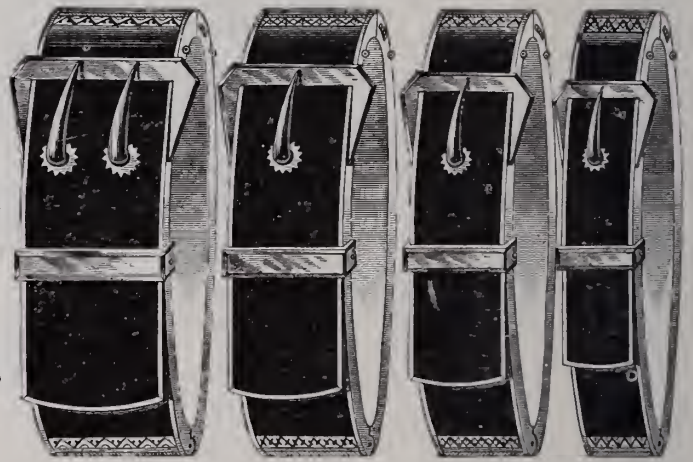

152 3/4 in. 153 5/8 in. 154 1/2 in. 155 3/8 in. 132 3/4 in. 133 5/8 in. 134 1/2 in. 135 3/8 in.

BLACK ENAMEL AND PEARL.

PLAIN BLACK ENAMELED.

**C
H
A
I
N**

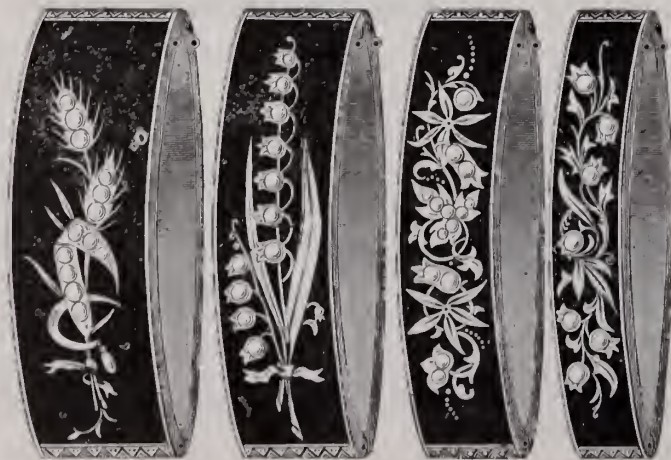

142 3/4 in. 143 5/8 in. 144 1/2 in. 145 3/8 in. 162 3/4 in. 163 5/8 in. 164 1/2 in. 165 3/8 in.

**C
A
N
E
S**

611 and 613 SANSON STREET, PHILADELPHIA.

W. WESLEY MOORE

hopes to add to his many friends in Ohio, Tennessee, Arkansas, Kentucky, Missouri, Illinois, Iowa, Kansas, Nebraska, Colorado, New Mexico, Wyoming, Utah, Montana, Nevada, California, Arizona and Oregon.

NEW DESIGNS.

Mr. BRADLEY

will call at regular intervals in Illinois, Wisconsin, Michigan, Minnesota, Dakota, Montana, Iowa and Indiana. Headquarters, Chicago, - - Illinois.



J. L. CLARK

hopes to receive the favors of his patrons in New York, Massachusetts, Connecticut, and Vermont.

We, the undersigned, representatives of the above well-known house, would announce to our respective friends that we will show them this Spring many new attractions, in addition to our usually large and varied stock.

We aim to merit your continued patronage and confidence.

Very Respectfully,

*W. Wesley Moore
Mr. Bradley
J. L. Clark
J. C. Address
H. C. Barnum
H. S. Colyer*

J. C. ADDRESS

will continue to call on his friends in Maryland, Delaware, District Columbia, Virginia, W. Virginia, North Carolina, South Carolina, Georgia, Florida, Alabama, Mississippi, Louisiana, Texas Tennessee, Kentucky and Ohio.

H. C. BARNUM

will renew his many acquaintances in Massachusetts, New York, Ohio, Indiana, Illinois and Michigan. Headquarters, Syracuse, - - - N. Y.

ATTRACTIVE GOODS.

FRESH STOCK.

LOW PRICES.

H. S. COLYER

will represent the house in Massachusetts, Maine, New Hampshire, New Jersey, Pennsylvania, Ohio and West Virginia.

CLEMENS HELLEBUSH,

MANUFACTURER, IMPORTER AND WHOLESALE JEWELER,

Dealer in everything required by the Jewelry Trade.

DIAMONDS.—Dealers will find in my stock an assortment of Diamonds unequalled in the West, embracing a choice variety of loose and mounted Stones in all qualities.

WATCH CASES.—In Gold and Silver, of all makers, to fit American Movements.

WATCH MOVEMENTS.—Include always a full stock of Waltham, Springfield, Hampden and Howard, together with a large assortment of fine and low-priced Swiss Watches.

SILVER PLATED WARE.—I have an unusually fine assortment of the choicest patterns of Flat and Hollow Ware of the best known manufacturers.

SOLID GOLD AND ROLLED PLATE JEWELRY.—This department is replete with Staple Goods and Novelties.

FRENCH CLOCKS.—Of our own importation, including all grades, with prices exceedingly low.

AMERICAN CLOCKS.—I am the General Agent in Cincinnati for the celebrated Seth Thomas Clocks, a full line of which will always be found in stock.

TOOLS AND MATERIALS.—In this department will be found everything required by Watch Makers.

Illustrated Catalogues sent to Dealers only upon Application.

CLEMENS HELLEBUSH,

77 West 4th Street,

CINCINNATI, O.



MELVILLE STEM-WINDER.
In Coin Silver Hunting Cases, 1½ and 2 oz.
Boys' and Girls' Sizes.

Fit 8 Size Elgin Cases.

Each Movement Warranted by Special Certificate.

MELVILLE KEY-WINDER.
In Coin Silver Hunting Cases, 1½, 2 and 3 oz.
Boys' and Girls' Sizes.

These Watches are Undoubtedly Superior to any in the market offered for the money.

HENRY MAY,

WHOLESALE JEWELER,

Importer of WATCHES and DIAMONDS, and Dealer in all AMERICAN MOVEMENTS,

19 JOHN STREET, near Broadway, NEW YORK.

N. B.—Goods sent on approval to any Responsible House.

T H E

E. HOWARD WATCH AND CLOCK CO.,

—MANUFACTURERS OF—

Fine Stem-Winding Watches,

FINE REGULATORS, OFFICE CLOCKS, TOWER CLOCKS,
And Electric Watch Clocks.



LADIES'
6 Size.

STEM-WINDING
AND



GENT'S
16 Size.

Stem-Setting
Movements.



GENT'S
18 Size.

114 TREMONT ST., BOSTON.

29 MAIDEN LANE, New York.

J. W. J. PIERSON, Agent.



WILLEMIN WATCH CASE CO.,

109 Sands Street, Brooklyn, N. Y.



In response to numerous enquiries respecting prices of our Cases, would say that we have made no change from prices of last year.

We are not in competition with houses whose productions contain more copper than conscience. But we do make an honest Case that will stand criticism and the assay of the United States Mints.

Our Factory is taxed to its utmost capacity to keep up with orders; our friends will, therefore, kindly not ask us to send goods on approval.

All our Cases are fully warranted to be as represented, and prices are as low as is consistent with quality, workmanship and finish.

MATHEY BROS. & MATHEZ,

NO. 16 MAIDEN LANE.

IMPORTERS OF ALL GRADES OF

Plain and Complicated Watches and Movements

SOLE AGENTS FOR THE WELL-KNOWN

H. L. MATILE



REPEATERS.

Fine Watches of Astronomical Precision.



CHRONOGRAPHS.

In order to facilitate the handling of our Stem-Winding Movements, we have adopted a standard of sizes to fit American Cases. Of these we have a complete line from the medium grade to the highest class goods of fine adjustment and precision. As all our Movements, complicated and plain, are perfectly uniform in quality according to their respective grades, we can furnish material for any parts that may be required, with the positive assurance of accurate interchangeability.

An Extensive Line of all Grades of

CHRONOGRAPHS, SPLIT SECONDS AND REPEATERS. WATCHES DEMAGNETIZED.

TENTH AND CHESTNUT STREETS, PHILADELPHIA.

MORGAN & HEADLY,

MANUFACTURERS OF

↳ GOLD, SILVER AND STEEL ↳

EYE-GLASSES & SPECTACLES.

OUR TRADE GROWS APACE.

We are constantly improving our Patterns and Machinery, and Educating our Employees, thereby advancing the standard of our business.

The coming season will prove us to be still going ahead in our Special Line. With more extensive Stock and Facilities, and everything advanced except Prices, which are uniformly low, we invite a continuance of your patronage.

IMPORTERS OF DIAMONDS.

Keeping a full assortment, including matched pairs of fine quality, which we will send to the trade on memorandum, at low prices, on receipt of satisfactory reference.

MORGAN & HEADLY, Tenth and Chestnut Streets, Philadelphia.

ROGERS, SMITH & CO.,

MANUFACTURERS OF

Electro Gold
AND
Silver Plated
Ware.

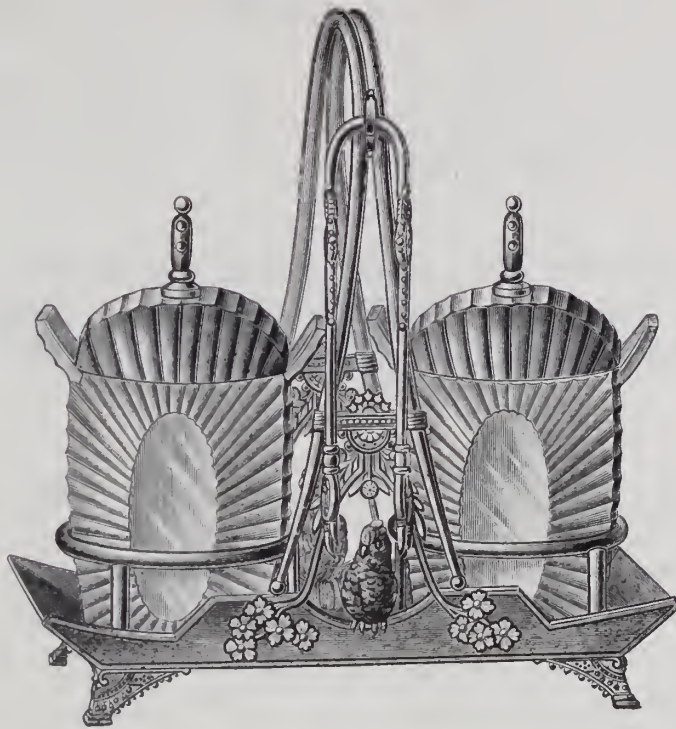

SALESROOMS:

46 EAST 14th STREET,
UNION SQUARE, N. Y.

FOR THE TRADE ONLY.

FACTORY, - - - MERIDEN, CONN.

INVALUABLE.



Patented March 20th, 1883.



SELF SIZING,

WITHOUT CUTTING or SOLDERING.

Simple, Durable, Handsome, Inexpensive.

MANUFACTURED BY

R. HENRICH,

35 Maiden Lane, NEW YORK.

FOR SALE BY ALL JOBBERS.

ESTABLISHED 1844.

DENNISON MFG CO.,

BOSTON, NEW YORK, PHILADELPHIA, CHICAGO, CINCINNATI AND ST. LOUIS.

JEWELERS' FINDINGS.

PAPER JEWELRY BOXES IN ALL STYLES AND QUALITIES. IMITATION MOROCCO BOXES, SATIN LINED. TAGS, JEWELERS' CARDS, PINK AND WHITE COTTON, &c., &c.

MOROCCO CASES.

Manufacturing in our own Shops Every Description of Morocco, Plush and Velvet Jewelry and Silverware Cases in large quantities, we are enabled to sell lower than other goods of equal quality can be offered, and we carry in all our Stores FULL Stock of our whole line.

Catalogue on Application.



13 Maiden Lane,

NEW YORK.

FRANK S. KENNEDY,

Manufacturer and Wholesale Dealer in

JEWELRY

OF EVERY DESCRIPTION.



13 Maiden Lane,

NEW YORK.

In addition to my stock of Jewelry, which is complete in all lines of Gold, Silver and Roll Plate, I am now making a Full Assortment of

⚡ **THIMBLES.** ⚡

in Solid Silver, 10 karat and 14 karat Gold. These Thimbles are Superior in Finish to any now in the market, and are as near perfection as long practical experience can make them. Will send Samples if desired.

The Assortments of Jewelry I send on Memorandum for Special and Stock Orders have an increasingly high reputation.

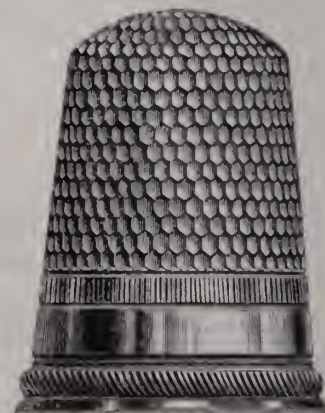
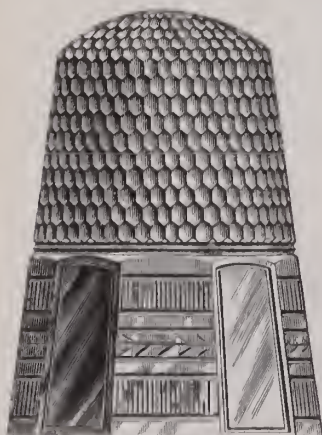



KREMENTZ & CO.



MANUFACTURING JEWELERS,

OFFICE:

FACTORY:

192 BROADWAY, N. Y.

NEWARK, N. J.

Rings, Pins, Ear-Drops, Seals, Locketts, Charms.

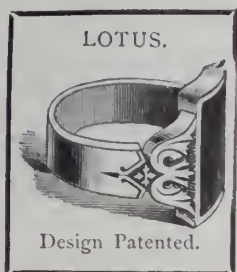

Diamond, Pearl, Onyx and Roman Gold Jewelry.



DIAMOND MOUNTINGS.

LONGINES CHRONOGRAPHS



Fly-Back & Horse-Timing

STEM-WINDING

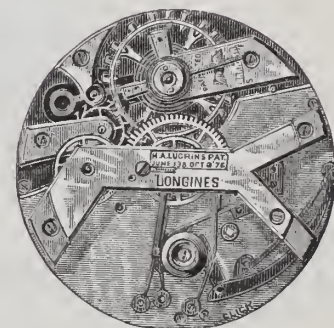

The most reliable, accurate and substantial LOW PRICE Timing Watch made. The improved method of mechanism in their construction renders these goods superior to any low price Timing Watch in the market, and the Best Selling Goods offered to the Trade.

J. EUGENE ROBERT,

30 MAIDEN LANE,

NEW YORK.

FOR SALE BY THE LEADING JOBBERS.

Duplicate Parts and Finished Material for these Goods always in Stock.



GEO. H. RICHARDS, JR.,
 383 WASHINGTON STREET,

BOSTON, MASS., U. S. A.



AMERICAN MOVEMENTS AND CASES A SPECIALTY.

We Guarantee to have ALL GRADES in Stock.

MOVEMENTS.

WALTHAM.

SPRINGFIELD, ILLS.

HAMPDEN.

ELGIN.

HOWARD.

→: CASES. :←

GOLD

WALTHAM.
 DUEBER.
 BROOKLYN.
 G. H. R., Jr.

FILLED

"BOSS."
 CROWN.
 LADD.

SILVER

WALTHAM.
 DUEBER.
 FAHYS.
 KEYSTONE.

Watches, Jewelry and Silver Plated Ware. Rogers & Bro.'s Flat Ware.

HOLLOW AND FLAT WARE SOLD AT MANUFACTURERS' DISCOUNTS.

Our Stock is positively the Largest, Finest and Best Assorted of any Jobbing House in the Country. All Orders Promptly Executed.

GEO. H. RICHARDS, Jr., 383 Washington Street, Boston, Mass.

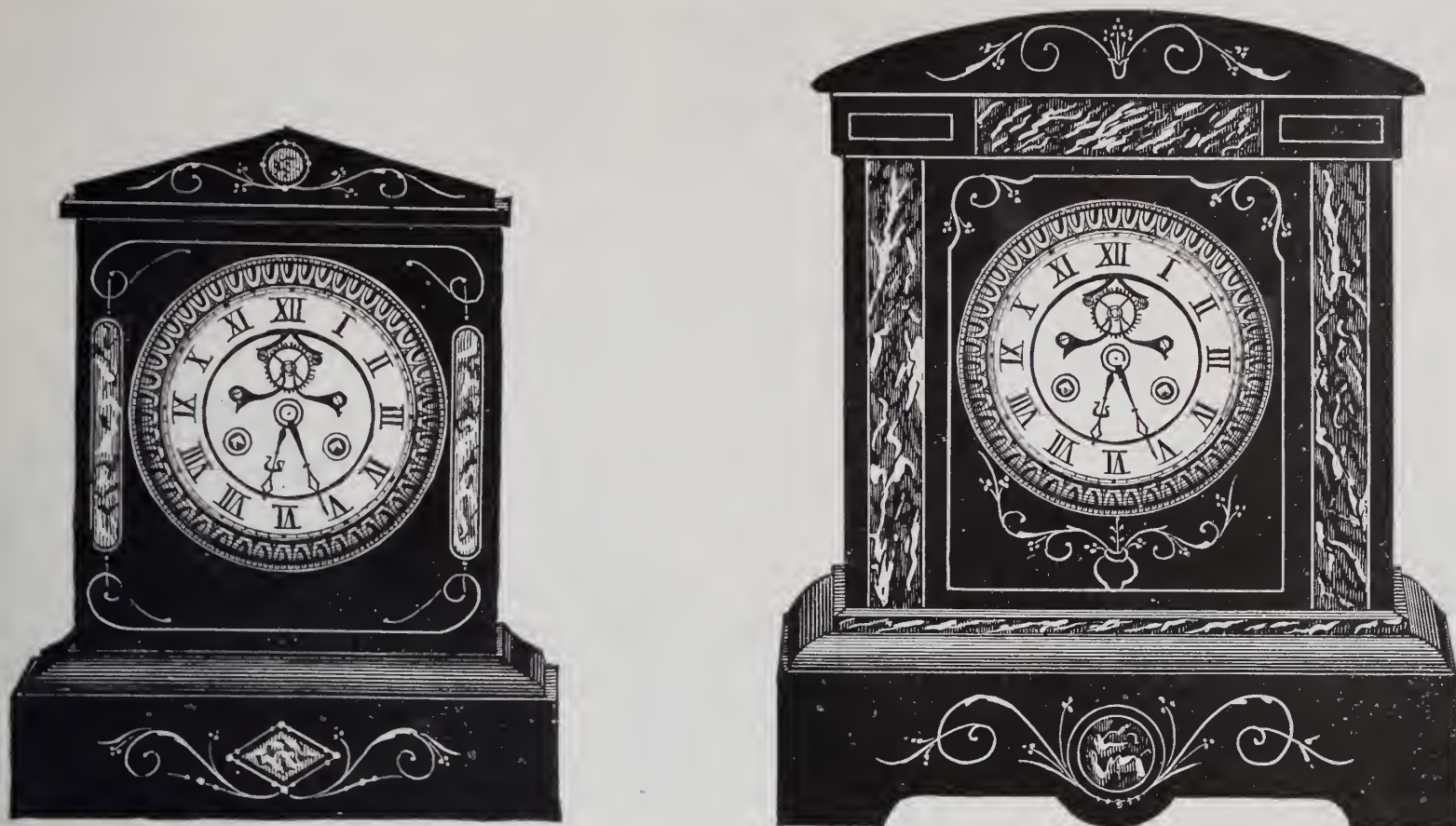

Our Catalogue of FRENCH MARBLE GONG CLOCKS is now ready, and will be sent to the trade ONLY on application.

LE BOUTILLIER & CO.,

Importers and Jobbers,

3 Union Square,

NEW YORK.

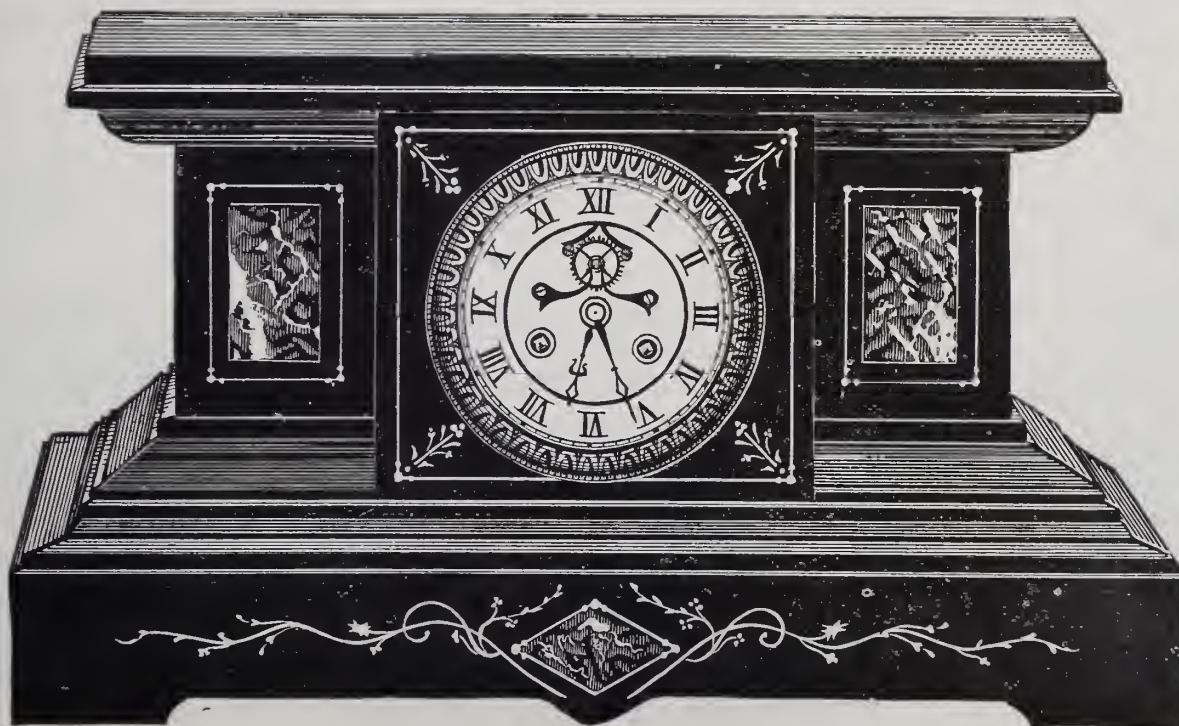

IMPROVED CROWN FILLED CASE.



Raised Gold Ornamentation.

THE BEST

FOR THE

Least Money.



Raised Gold Ornamentation.

The Gold contained in the Crown Cases which are now being turned out under our supervision IS FULLY EQUAL TO THAT OF ANY FILLED CASE ON THE MARKET.

This fact can be attested to the satisfaction of any dealer who will go to the trouble of having one of these Cases assayed with one of corresponding size and style of ANY OTHER MAKE.

The United States Mint at Philadelphia will make a complete assay for the sum of one dollar each, and we will return a New Case to the dealer in place of the one of our make destroyed, upon receipt of the Assay Certificates and the gold contained in the Crown Case assayed.

SOLID GOLD JOINTS.

SOLID GOLD PLUGS.

GOLD THE NATURAL COLOR.

ABSOLUTELY NO GILDING.

SOLD ONLY BY THE JOBBING TRADE.

H. MUHR'S SONS,
PHILADELPHIA.



Raised Gold Ornamentation.

NEW YORK OFFICE,
1½ Maiden Lane.

CHICAGO OFFICE,
137 State Street.



Raised Gold Ornamentation.



1380



1162



1687



93



1476



0027



864

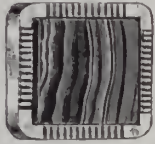

1206



1479



0041



1234



0024



1420

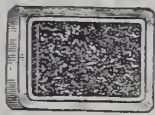

1369



1239

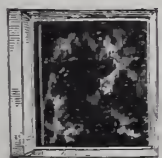

1321



1235



1340

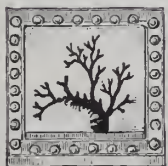

017



93

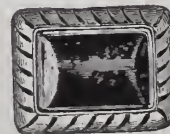

02

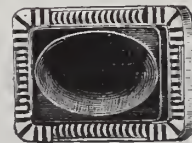

1182



634

THE

ACME LEVER BUTTON



OPEN.



CLOSED.



OPEN.



OPEN.



CLOSED.



CLOSED.



1257

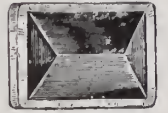

1582



0025



1003



020C



869



1437



1269



1502

Always was, is now, ever shall be
THE MOST CONVENIENT,
STRONG, RELIABLE and PERFECT SLEEVE BUTTON MADE

It Overcomes
ALL TROUBLE WITH STIFF CUFFS.

ASK YOUR JEWELER FOR THE
ACME LEVER SLEEVE AND COLLAR BUTTON,
AND TAKE NO OTHER.

For Sale by all Jobbers of Jewelry.

E. E. KIPLING,
 — IMPORTER OF —
PRECIOUS AND IMITATION STONES,
No. 6 Maiden Lane, New York.

For the protection of the trade I find it necessary to issue the following **TRADE MARK.**



which will hereafter be embossed or printed on all cards containing Jewelry in which is set my Patent Foiled Solid Metal Back Rhine Stone Brilliants, in place of the below stamps, which were formerly employed and which have been **ABOLISHED.**

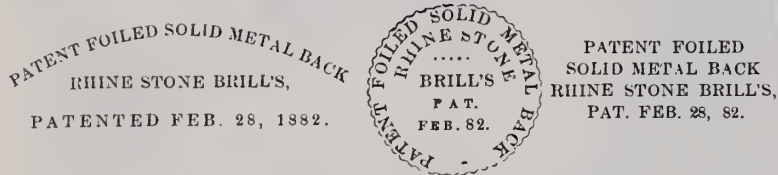

All Jewelry containing my Patent Foils, made after this date, will bear my **TRADE MARK.**

Very Important to Jobbers and Retail Jewelers.

In buying White Stone Jewelry, be sure to get "**Patent Foil Solid Metal Back Rhine Stone Brilliant.**" The Cards must be stamped as above. The advantages over the **PAINTED FOILS** ARE:

- They are more Durable.**
- " are not affected by washing or dampness of air.
- " retain their Lustre.
- " preserve their Purity of Color.
- " are sold at the same price as the Painted Foils.
- " are sure to give satisfaction.

See that all the Jewelry Cards are Stamped with my Trade Mark.

All violations of my rights, whether under my patent or my trade mark, will be prosecuted to the full extent of the law.

My customers are respectfully requested to inform me of any infringements that may come to their knowledge, so that I may be the better able to protect them from unlawful competition.

E. E. KIPLING.

J. M. CHANDLER & CO.,

—MANUFACTURERS OF THE—

PATENT EMBOSSED BRACELET.

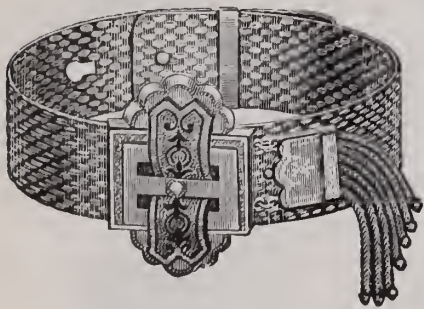

These cuts represent examples of one of the many styles of our New Patent Embossed Bracelet.



Chain Bracelets either in Gold or Plate are necessarily weak, as a small rivet is used to connect the links; when one rivet fails, the whole comes apart. The Embossed Bracelet is an exact imitation of a chain made from a solid piece of stock by a patent process, and while the goods are of the best quality, the price is much lower.

The stock from which these goods are made is plated in our factory, and we **GUARANTEE** each and every pair to wear and give satisfaction. They are adjustable and will fit any arm.

We will send Selection Packages of the Goods to Dealers on Approval.

ADDRESS ALL ORDERS TO

J. M. CHANDLER & CO.,

JOBBERS IN ALL KINDS OF

CLOCKS, WATCHES, JEWELRY, AND ALL KINDS OF TOOLS AND MATERIALS,

185 Superior Street, Cleveland. O.



EVERY ONE KNOWS THAT THIS STANDS FOR STRENGTH.

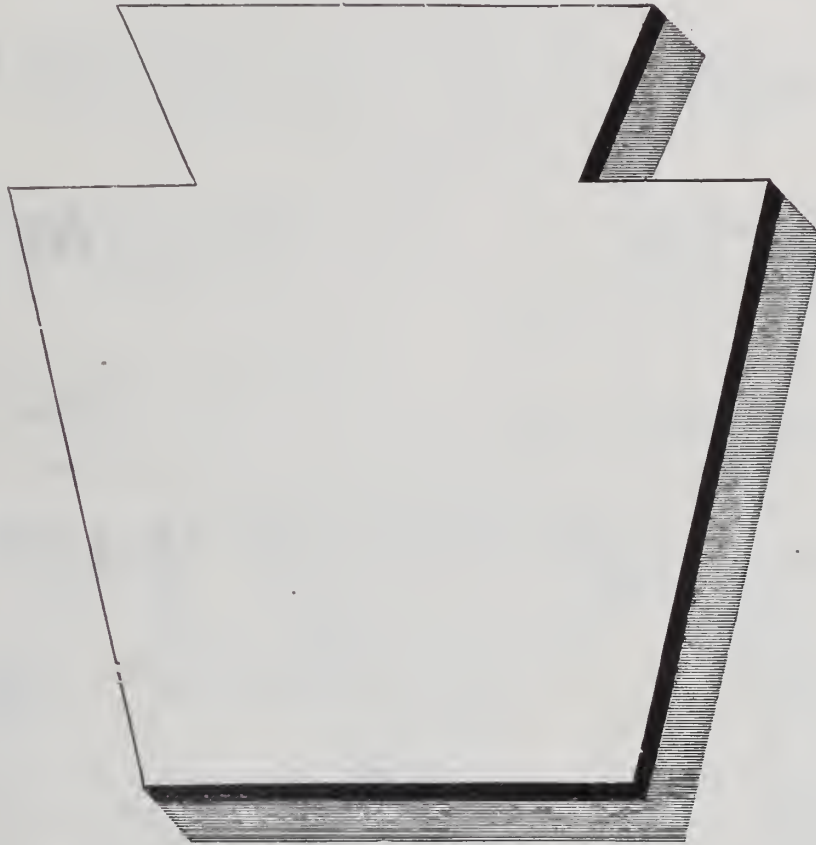

Every one will say if they will examine the

*Keystone Improved Coin Silver Watch Case,
as a Practical Man recently did, "That they are the Strongest
Case made," and they will also find the Full Bascine the most
Perfect Case.*

*→*Examine Them.*←*

LOUIS KAHN.

MOSES KAHN.

SAMUEL H. LEVY.

I. W. FRIEDMAN.

L. & M. KAHN,

IMPORTERS OF

Watches, Diamonds & Precious Stones,

10 MAIDEN LANE, NEW YORK.

11 Corratere, Geneva, Switzerland.

17 Rue de Chateaudun, Paris.

WATCHES,

Stem and Key-Winding, from the Lowest Priced Nickel and Silver to the Finest Gold and Complicated.

A Full Assortment of these Goods always in Stock.

DIAMONDS,

Loose and Mounted, in all Sizes and Qualities.

Gold, Silver, Nickel and Celluloid Chatelaines in Great Variety.

STANDARD DUST-PROOF WATCH KEYS.

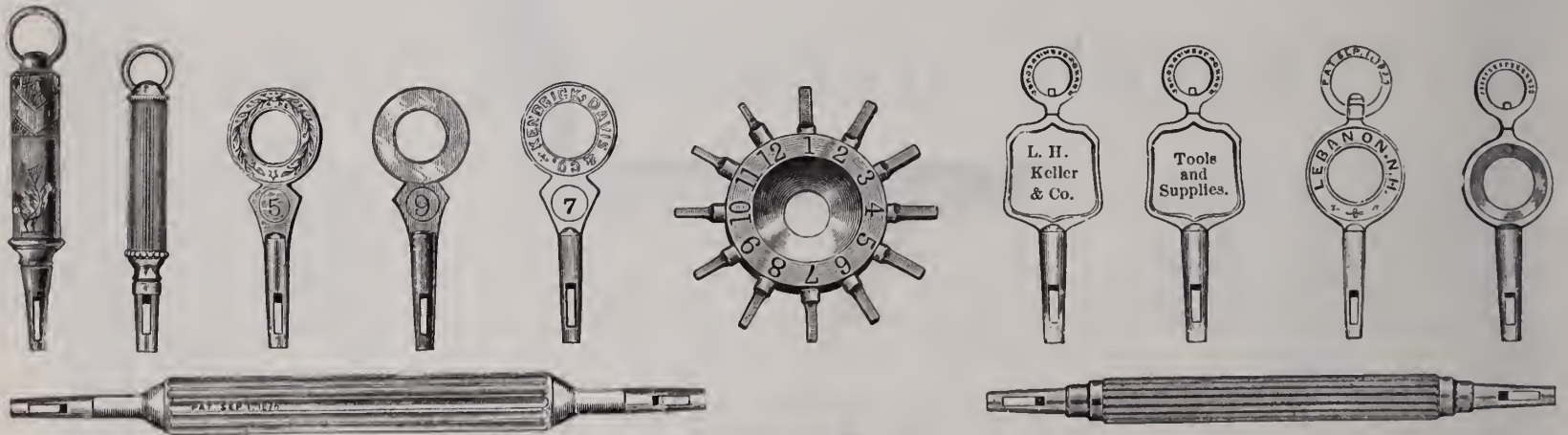

FOR SALE BY



THE TRADE.

KENDRICK & DAVIS,

Sole Owners and Manufacturers, Lebanon, N. H.

ILLUSTRATED CATALOGUE AND PRICE LIST SENT ON APPLICATION.

"The Waterbury." The New "Series B,"

With FULL DIAL and SOLID PLATES.

NEW SERIES B.
Bezel Off,
Showing Index Plate and Regulator.

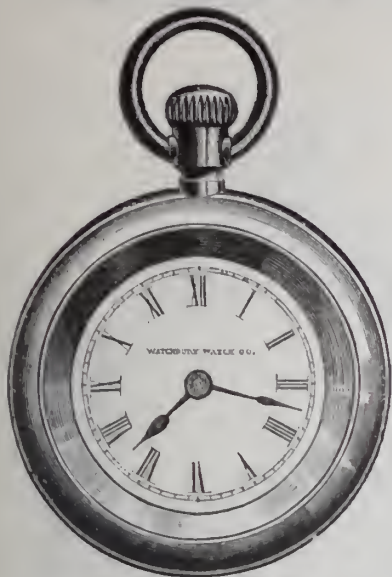

NEW SERIES B.
Solid Plates and Full Dial.

In this new SOLID PLATE movement the position of the regulator has been changed; it will be found projecting beyond the plate, immediately under the bezel. The FULL DIAL enables the position of the hands to be readily seen.

The danger of injuring the Hair Spring in regulating is obviated in this new movement.

SERIES A.—Open Dial, Skeleton Plates, - \$48.00 per doz.
SERIES B.—Full Dial, Solid Plates, - - - 48 00 "

Discount to the Trade.

We can supply either Pattern as ordered.

WATERBURY WATCH CO.,
WATERBURY, CONN.

NEW YORK OFFICE, 4 MAIDEN LANE.

GEO. MERRITT, GENERAL SELLING AGENT,

To whom all Orders and Correspondence as to Prices and Terms should be addressed.

FOR SALE BY DEALERS GENERALLY.

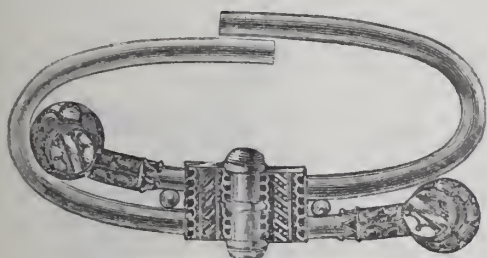

225

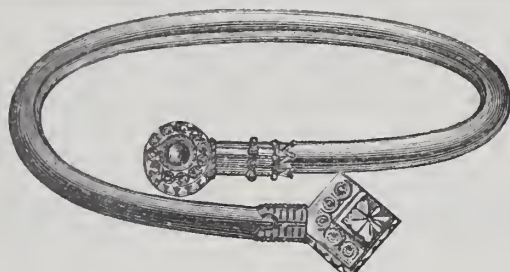

214

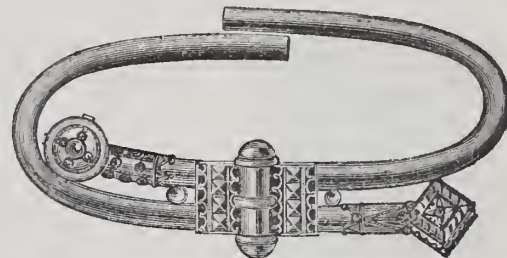

222

ELLISON & VESTER'S
PATENT

BAND AND BANGLE FINE ROLLED PLATE
BRACELETS,

For Sale by Every Jobber.

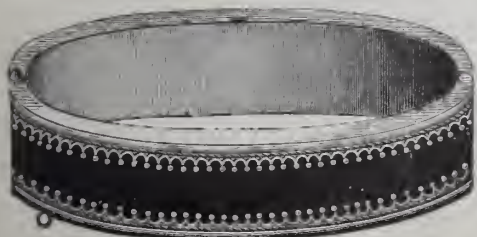

179

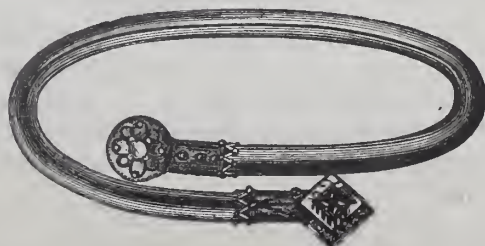

213



178

THE WINDSOR SLEEVE LINK

PATENTED MARCH 13, 1883.

The Manufacturers of the Windsor Lever Sleeve Button have just introduced this Elegant, Novel and Unique Sleeve Link, named

The Windsor Sleeve Link,
THE MOST CONVENIENT AND PERFECT SLEEVE LINK MADE.

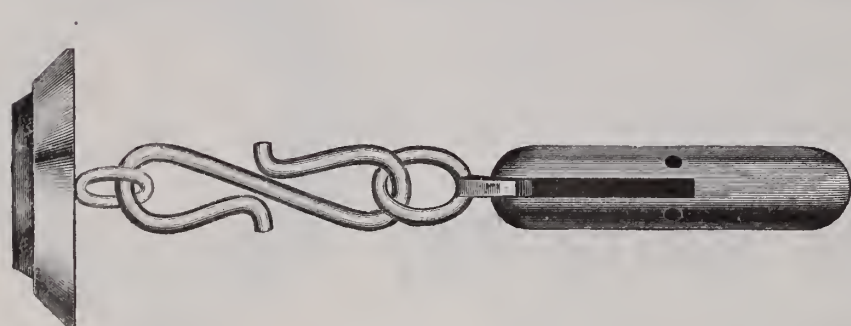

OPENED.

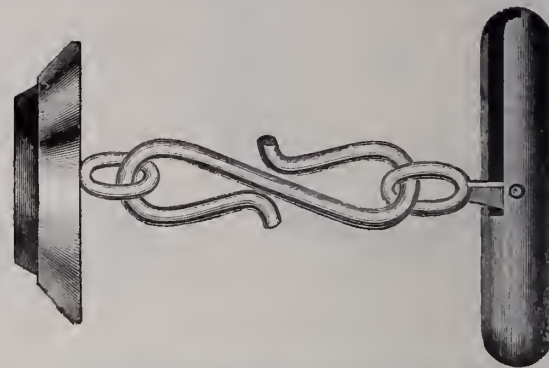

CLOSED.

The above Illustrations show the slotted bar open ready for entering in the cuff, and closed after being secured in place.

These Sleeve Links are made of Fine Rolled Plate and Warranted to Give Satisfaction.

SOLD BY ALL LEADING JOBBERS.

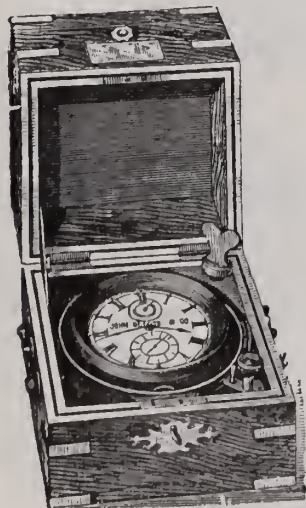

Standard Marine Chronometer
FOR KEEPING CORRECT TIME.

JOHN BLISS & CO.,
Standard Marine
CHRONOMETERS AND TRANSITS
FOR WATCHMAKERS' USE.

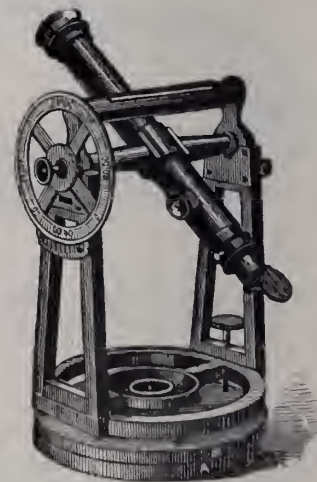

No. 10

128 FRONT STREET, NEAR WALL STREET, NEW YORK.

IMPORTANT NOTICE.—These Transits are readily set in position without the aid of strictly correct time as a basis for that purpose. Printed instructions, easily understood, accompany each Instrument, and no calculations are required preliminary to setting in position.

As a trial only is required to insure unqualified approval, we are induced to make the following **LIBERAL OFFER**—On receipt by us of satisfactory reference, and 10 per cent. of the price, we will send one of the foregoing Transit Instruments, on hire or trial, for one month, with full printed instructions for setting up and using the same, and if purchased after trial, we will allow the whole hire to apply in part payment, and sell the Instrument on approved note at four months for the balance. Special terms for payment by installments, after trial, on application. We do not make this offer merely to hire these instruments, but to insure a trial with a view to sales, the hire received being only sufficient to cover the cost of repolishing in case they are returned. Send for Illustrated Circular giving full description.

JOHN BLISS & CO., 128 Front Street, (between Wall and Pine Sts.) New York.

STANDARD WATCH CO.



STANDARD CALENDAR

"STANDARD CALENDAR."

20 Line, Open Face, in Nickel and Silver, showing the date and day of the week, Full Jeweled, Finished Movement. The Latest Novelty offered.



"STANDARD."

18 Size, Low Price Movement, will fit Waltham and Elgin Cases.

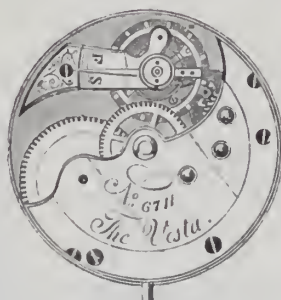

"VESTA."

8 Size, Low Price Movement, fits Elgin Cases.



"STANDARD."

8 Size, Full Jeweled, Ladies. Fits Waltham Cases.

REGISTERED.



"STANDARD."

Nickel, 17, 19 and 20 Line. Lever, Full Jeweled.

Max Freund & Co., Sole Agents, 8 Maiden Lane, N. Y.

ESTABLISHED 1858.

THE

ORGANIZED 1883.

LADD WATCH CASE COMPANY

Successors to J. A. Brown & Co.,

MANUFACTURERS OF THE

Ladd Patent Gold Watch Cases

Office & Salesroom:

No. 11 Maiden Lane,
New York City.

Unequaled for **WORKMANSHIP, STYLE,**
DURABILITY and **FINISH.**

Manufactory:

No. 104 Eddy Street,
Providence, R. I.

Examine our New Model ACME Ladd Case, which is universally pronounced on sight, to be the Most Elegant and the Best article in this line yet brought out.

It has all the Late Improvements, including Solid Gold Linings and Solid Gold Bows, and the shape is such as to allow the Most Elaborate Ornamentation, or any intermediate style, down to the plainest, without loss of effectiveness, according to the taste of the purchaser.

KELLER & UNTERMAYER,

NO. 9 MAIDEN LANE,

—‡ New York. ‡—

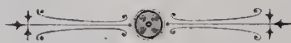

MAKERS OF

ARTISTIC GOLD WATCH CASES,

In Raised Ornamentation, Inlaid and other Unique Decorations,
and in New and Original Designs.

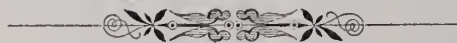

The New Styles of Embellishments introduced in these Cases
render them the Most Effective and Popular Goods made.

Every Design is a Work of Art in itself, and is worked out
with a Perfection of Detail never before seen in Watch Cases.

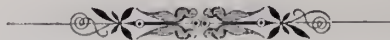

Especial and Appropriate

—‡ DESIGNS ‡—

suitable for PRESENTATION and
other purposes.



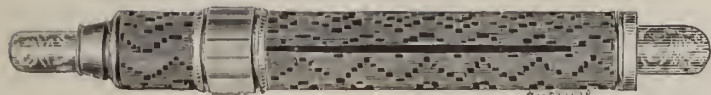

Established
1841.



JOHN HOLLAND,

19 and 21 WEST 4th STREET,

CINCINNATI, OHIO.

Manufacturer of All Styles of Best Quality

GOLD PENS, PENCIL CASES, FINE PEN HOLDERS, GOLD TOOTH PICKS, &c.

A Large Variety of New Designs in Staples and Novelties.



Received the Award "For Great Elasticity and General Excellence of Gold Pens," at Phila. Ex., '76.
Catalogues mailed free. Handsome show cases loaned for display of goods.

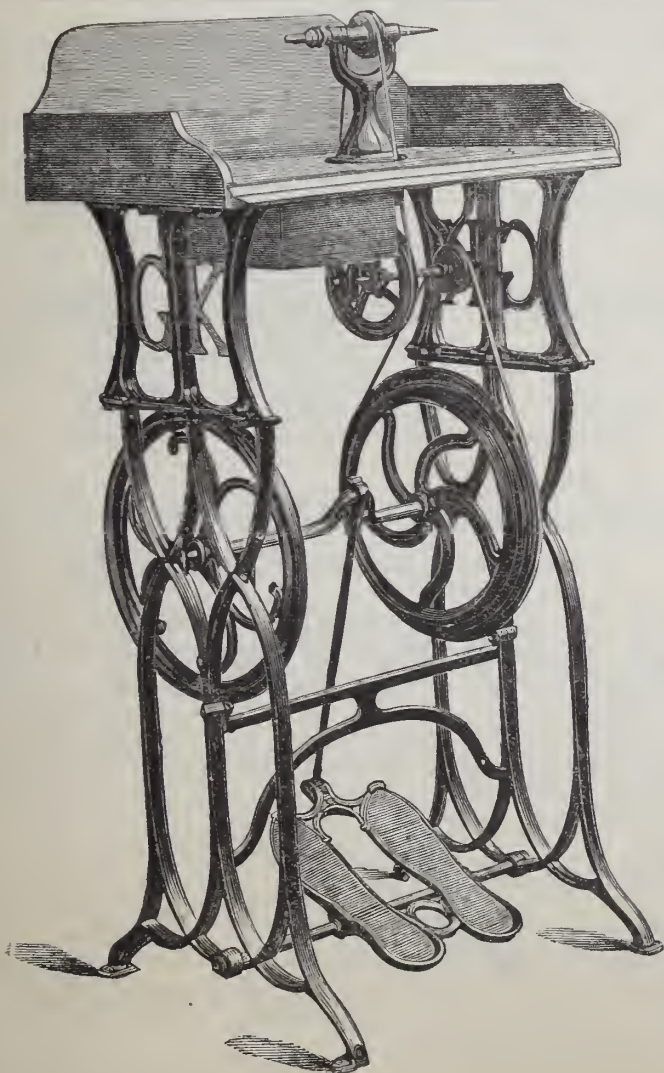

This Cut represents the
Latest Design in

Watch Glass Cases.

—o—		
PRICE OF CASE		
With 9 Drawers,	\$9.00	
" 11 "	10.00	
" 13 "	11.00	

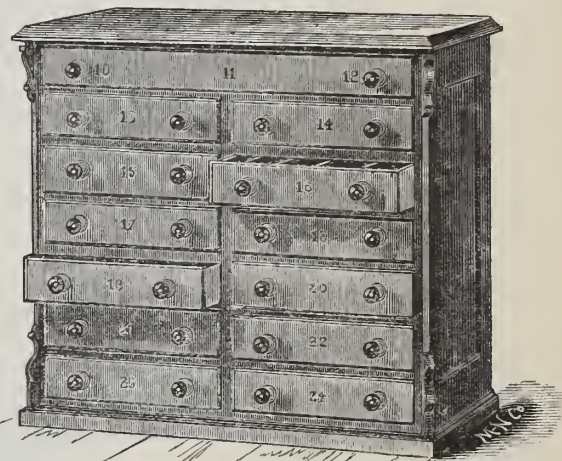

R. & L. FRIEDLANDER,

IMPORTERS OF

Watchmakers' and Jewelers' Supplies,

OPTICAL GOODS, ETC.

SOLE AGENT for the G. & K. POLISHING LATHE, Price \$10.50.

65 & 67 NASSAU STREET,

Branch, 264 Bowery,

Factory, 50 Bond Street,

NEW YORK.



GILES, BRO. & CO.

Wholesale,
Importing and
Manufacturing

JEWELERS,

Cor. State & Washington Sts.,

CHICAGO, ILLS.

Complete Illustrated Catalogue Furnished the
Trade upon Application.

LANCASTER WATCH CO.

MANUFACTURERS OF

A. BETNER'S
Patent.

DUST PROOF WATCHES,

Patented
Nov. 28, 1882.

Fine Nickel and Gilt Stem-Winders.

These Watches meet a want long felt by the Trade generally. The balance being entirely closed meets the point taken by Jurgensen in his remarks upon the Resistance of the Air, as found in the CIRCULAR AND REVIEW, January No., 1883, page 414. This movement is guaranteed to be Dust-Proof, no matter in what case it may be placed. It is interchangeable with our regular case, or can be put into the Regular 18-size cases in the hands of Jewelers or Watch Dealers everywhere.

FOR SALE BY LEADING JOBBERS THROUGHOUT THE UNITED STATES.

WILLIAM H. BALL,

Successor to BALL & BARNARD,

—MANUFACTURER OF—

GOLD JEWELRY.

Roman, Enameled and Engraved Band Bracelets, with the Safety Guard Attachment. This Safety Guard is Guaranteed and costs nothing additional.

ALSO A FULL LINE OF

Bangle, Braided and Padlock Bracelets.

OFFICE, 9 JOHN ST., N. Y.

SAN FRANCISCO OFFICE, 120 SUTTER ST.

FACTORY, NEWARK, N. J.

Goods Sent on Selection to Responsible Parties.

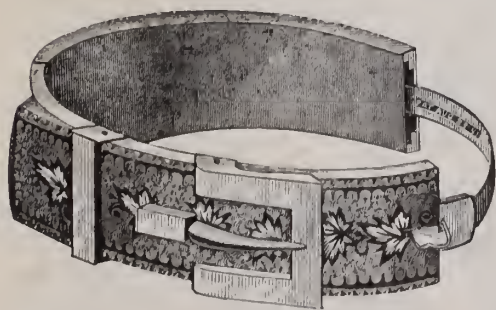

PETER B. SIMONS & CO.,

MANUFACTURERS AND IMPORTERS OF

FINE JEWELRY,

GOLD CHAIN,

Gold and Silver Thimbles, Canes, Sets, Etc.,

FOR THE TRADE ONLY.

No. 120 SUTTER STREET,
SAN FRANCISCO.

FACTORY:
611 & 613 SANSON STREET,
PHILADELPHIA.

SALESROOM:
120 SUTTER STREET,
SAN FRANCISCO.

DEALERS IN AMERICAN AND IMPORTED

❖ GOLD ❖ AND ❖ SILVER ❖ WATCHES. ❖

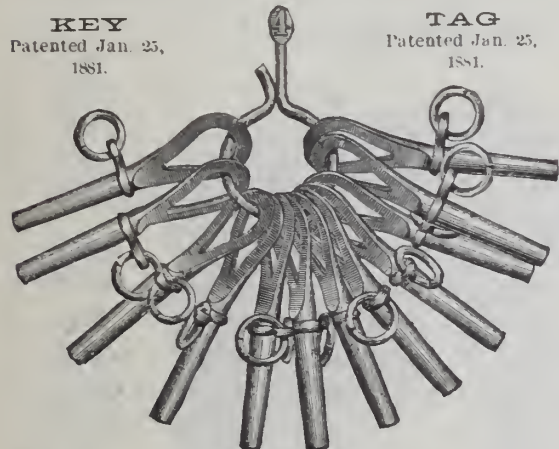

KEY
Patented Jan. 25,
1881.

TAG
Patented Jan. 25,
1881.

A. N. CLARK
PLAINVILLE,
CONN.,

Manufacturer of

Watch Case Springs, Watchmakers' & Jewelers' Bench Tools,
CROSBY'S JEWELING TOOLS, &c.

STOP IMPORTING KEYS!

For Low Price Key Use the

New Style Loop Key.

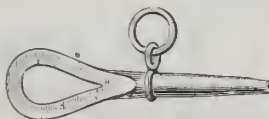

A plain Steel Key of good appearance, and excellent quality. It will not wear the pocket. It has a swivel, and is much better made than the imported plain steel or iron keys.

PRICE PER GROSS, FINE NICKEL FINISH, \$2.25
Postage, 10 Cents Per Gross Additional.

This Key is good and cheap enough to become universal. Send business card for illustrated price list. Enclose three cent stamp for sample key.

SOLD BY JOBBERS IN WATCH MATERIALS AND NOTIONS.

A. N. CLARK, Plainville, Conn.

PATENT CANE CASE.

Certain parties having infringed on our Patent for this most desirable Case, we now give notice that they can hereafter only be procured from us with safety.

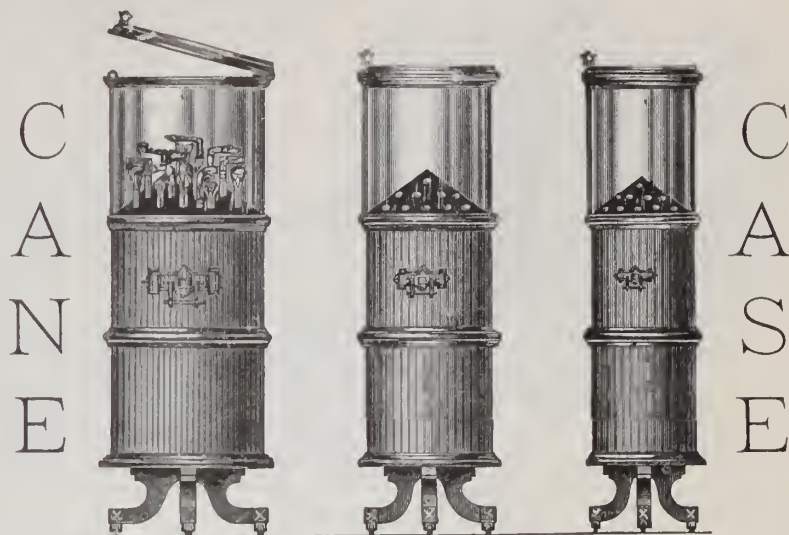

GOLD, SILVER and COPPER HEAD CANES in New Designs and Applied Work, in Greater Variety than can be found elsewhere.

SIMONS, BRO. & CO..

611 & 613 Sansom St., PHILADELPHIA.

MANUFACTURERS OF

Cane Heads, Gold Chain, Bracelets, Thimbles and Fine Jewelry.

AMERICAN WATCH TOOL CO.,

WALTHAM, MASS.

P. O. Box 999.

Manufacturers of the Whitecomb Lathe, and Machinery for Watch, Watch Case and Clock Making.

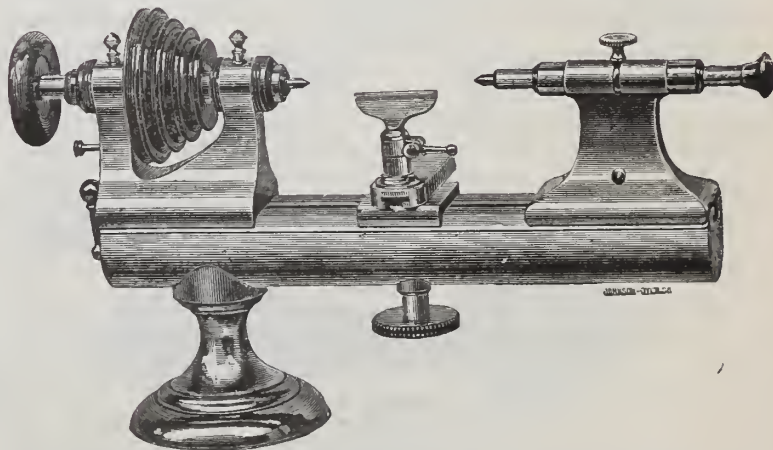

SEND FOR NEW CATALOGUE.

Our No. 1½ Lathes are Fast Superseding all other Sizes.

Soft Lathes have Hard Mouths, Hard Wire Chucks and Hard Tail Stock Spindles.



PRICES OF
CARVED FLANGE
Watch Signs.

9 Inch.....	\$5.00
12 ".....	7.00
14 ".....	8.00
16 ".....	9.00
18 ".....	11.00
22 ".....	14.00

Our Watch Signs are made of Metal and consequently more durable than those made of Wood, as there is no danger of them checking or warping the same as Wooden Watch Signs.

We make our Dials Black, with White Figures, unless otherwise ordered. Our Watches and Flanges are Gilded with Pure Gold Leaf. Jewelers' and Opticians' Signs a Specialty. Discount to the Trade.

W. L. WASHBURNE & CO.

THE ORIGINAL SIGN AND WEATHERVANE MANUFACTURERS,
90 NASSAU STREET, N. Y.

SEND FOR ILLUSTRATED CATALOGUE.

Birch's Patent Self-Adjusting Watch Keys.

FOR SALE BY THE TRADE GENERALLY.



2.-POCKET KEY.
(Brass.)



3.-POCKET KEY.
(Nickel Plated).



4.-POCKET KEY.
(Nickel Plated, Hexagon Shell.)



5.-POCKET KEY.
(Heavy Rolled Gold Plate Mountings.)



6.-CELLULOID MOUNTED
KEY.
(With Heavy Rolled Gold Plate Tips.)



35.-POCKET KEY.
CELLULOID MOUNTINGS.
(Imitation Marachite, with Extra Heavy
Rolled Gold Plate Tips. 18. K.)



7.-BENCH KEY. (Brass Handle.)



8.-SHORT WOOD HANDLE KEY.
(Nickel Plated, for Bench or Pocket Use.)



9.-LONG WOOD HANDLE BENCH KEY. (Nickel Plated.)

Made in 37 Styles. Circulars on Application.

J. S. BIRCH & CO., 38 Dey Street, N. Y.

MARTINS & TISSOT,

Manufacturers of

GOLD WATCH CASES,

AND JOBBERS IN AMERICAN MOVEMENTS,

15 MAIDEN LANE, NEW YORK.

8 KARAT CASES A SPECIALTY.



Our 8 Karat Cases are of Superior

STYLE,

CONSTRUCTION

AND FINISH

to any now made, (as our constantly increasing production will attest), and are made also in large variety of styles.

LARGE STOCK

Constantly on Hand.

JOBGING TRADE SOLD ONLY.

THE

L
I
C
H
T
N
I
N
G

C
L
E
A
N
S
E
R

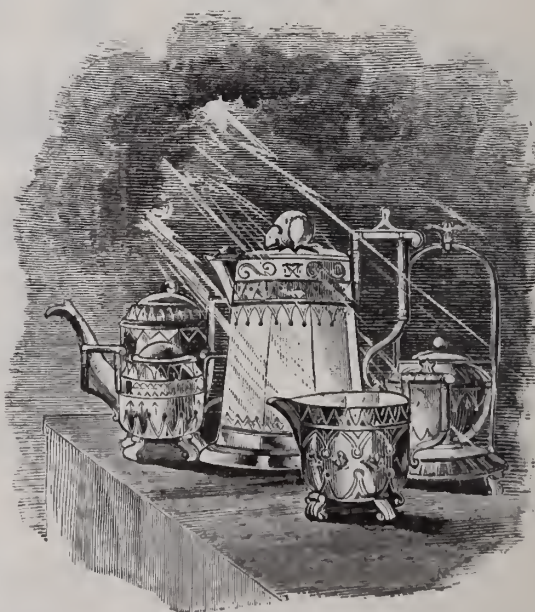

FOR ABSORBING TARNISH

FROM GOLD, SILVER PLATED WARE, CHASED GOODS AND NICKEL.

The striking peculiarity of this "CLEANSER" is that it does its work by absorption, and does not require rubbing and labor to get the article cleansed.

It contains no Poison, Acid or Alkali (including Ammonia and Cyanide), and is warranted to give entire satisfaction or money refunded.

MANUFACTURED BY

W. M. SCOTT & CO., Philadelphia, Pa.

And for Sale by Jobbers and Manufacturers of Silverware.

Price Per Gross reduced to \$12.00; or One Dozen sent, post paid, to any address in the United States on receipt of \$1.50; or One Package 25 Cents.

TRADE MARK

STERN BROS. & CO.
 Manufacturers of
FINE
JEWELRY.

Gold and Silver Thimbles,
 STONE RINGS & LOCKETS A SPECIALTY.

30 Maiden Lane, New York.

Factory, 17 and 19 John Street.

GOODS SENT ON SELECTION TO RE-POSSIBLE PARTIES.

The special attention of the trade is directed to our

Plain Gold Oval and Flat Filled Rings.

Cut Sections showing their construction mailed upon application.

WM. M. FISHER & CO.

Sole Manufacturers of the

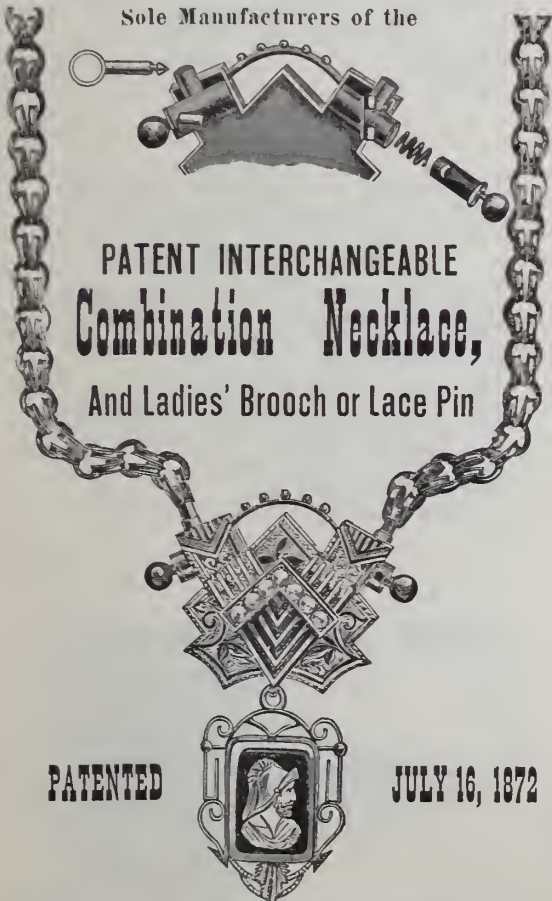

PATENT INTERCHANGEABLE
Combination Necklace,
 And Ladies' Brooch or Lace Pin

GOLD
 AND
 SILVER
 CHAINS.
 —:—
 Gold Chain
 TRIMMINGS.
 —:—

Complete
 Assortment of

14-k.

Ribbon Fobs.

PATENTED

JULY 16, 1872

FOR SALE BY THE LEADING JOBBERS

HUTCHISON & HUESTIS,

❖ SOLID ❖ GOLD ❖

RING MAKERS

QUALITY
 GUARANTEED.

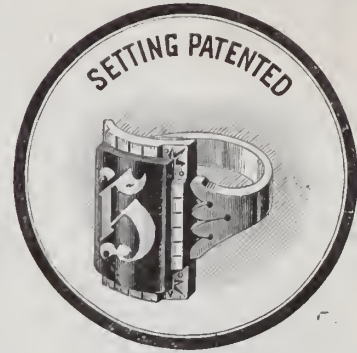

FOR
 JOBBERS ONLY.

No. 185 EDDY STREET,
 —❖ PROVIDENCE, R. I. ❖—

New York Office, . . . 196 Broadway.

The Burbank Manufacturing Company

Manufacturers of GOLD & SILVER

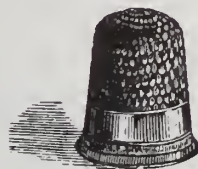

GOLD
 SILVER,
 STEEL,
 RUBBER,
 And SHELL,

Thimbles,



EYE GLASS
 Self Adjusting.

SPECTACLES AND EYE-GLASSES



OF ALL DESCRIPTIONS.

SOLID GOLD RINGS

Office, 14 MAIDEN LANE. NEW YORK.

Manufactory, Springfield, Mass.

NEW YORK OPTICAL CO.,
 Manufacturers of all kinds of
 Spectacle Lenses, Spectacles,
 Eye-Glasses
 AND
SPECTACLE AND EYE-GLASS CASES.
 OFFICE AND SALESROOM:
 No. 43 MAIDEN LANE, N. Y.
 FACTORIES: BROOKLYN, N. Y.

BOYCE & WAINWRIGHT,
Manufacturing Jewelers
 SOLID GOLD RINGS A SPECIALTY.
 Our BAND RING Specialties for PRICE,
 QUALITY and FINISH are not equaled by
 any in the Trade.
383 Washington St., Room 26,
 E. J. BOYCE.
 W. H. WAINWRIGHT. **Boston, Mass.**

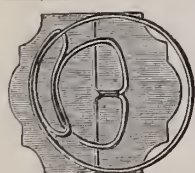

The "J. W." Safety Stud
 OR
CUFF BUTTON.
 Patented December 26th, 1882.

Its Shoe and Post are made of one continuous piece of wire. On its shoe there are two over-lapping lips, one turned outward and the other turned inward, which cause great ease to attach it to or detach the same from any shirt front or cuff. To attach, you insert the outer lip into the button-hole and turn the button to the right, and to detach, you insert the inner lip into the button-hole and turn the button to the left. There is no hinge, no lever and no separation about it, and is always ready for action and cannot get out of order as others do. *The Sole Right to Manufacture the above Button is for sale.* For a sample of the Button and particulars in full address the inventor.

JULIUS WEIS, 124 S. Clark St.,
 ROOM 13, **CHICAGO.**

H. M. RAYNOR
 No. 25 Bond St.,
 New York.
PLATINUM WIRE
AND PLATE
FOR JEWELERS.
 Scrap Purchased.

H. WUNDOEHL,
GOLD & SILVER REFINER,
 Assayer and Sweep Smelter,
21 JOHN ST.,
 Bet. Broadway & Nassau St., **NEW YORK.**
 The highest price paid for Gold, Silver and Platinum.
Fine Gold, Silver and Copper always on hand.

JACOB STRAUSS,
WATCHES & JEWELRY
AT WHOLESALE.
18 JOHN STREET, NEW YORK.
 Rings and Rolled Plated Chains
A SPECIALTY.

J. B. LAURENCOT,
 IMPORTER OF
WATCH GLASSES,
Optical and Fancy Goods
 French Clocks, Musical Boxes, &c.
No. 33 MAIDEN LANE.
 5 Rue D'Enghien, **PARIS.**
 Box 2954, P. O. **NEW YORK.**

W. H. LUDEMAN,
 No. 75 & 77 Nassau Street,
NEW YORK.
FINE AND COMPLICATED
WATCHES
 Of every description repaired and regulated.
Stem Winding and Escape Wheels
 Cut and finished to order with accuracy
 and promptness.

J. J. COHN,
 IMPORTER OF
 WHITBY JET,
 MANUFACTURER OF
Gold & Rolled Plate Jewelry,
 Bracelets, Charms & Locketts a Specialty.
12 MAIDEN LANE, N. Y.
 Goods Sent on Selection if Satisfactory References are
 Given.



THE JEWELER'S BOAT.
OSGOOD FOLDING CANVAS BOAT
 Is the boat to buy; you can fold it up and carry it in your buggy, or on your back; it is light, safe, and strong; it rows so easily, you can't blister your hands, or unsettle without considerable effort; the best portable or sportsmen's boat made in the world.
SALES AGENTS (U.S.A.) Send for Illustrated Circular, giving full particulars and references. Manufactured by
N. A. OSGOOD, Battle Creek, Mich.,
 —DEALER IN—
Fine Jewelry, Diamonds & Sportsmen's Goods.

L. SAUTER.
1 MAIDEN LANE,
 Manufacturer of
Fine and Diamond Jewelry
 AS
 Rings, Studs, Buttons, Scarf Pins, Etc.
Hair Jewelry in all its branches.
Jobbing of every description promptly attended to.

JOHN D. LENNON,
 142 Fulton Street,
NEW YORK,
Manufacturing Jeweler,
 Masonic Pins, Rings & Charms,
 School, Athletic, Fine
 Presentation Medals,
 —AND—
JEWELS OF EVERY DESCRIPTION
Designs furnished free upon application.



HIBBARD G. GILL,
GOLD AND SILVER
Watch Case Manufacturer,
 Dealer in Watches,
 American Watch Movements Always on Hand.
618 Chestnut Street,
 Fifth Floor. **PHILADELPHIA.**

HENRY TROEMNER,
710 Market Street,
PHILADELPHIA.
 Manufacturer of Fine Gold Scales,
DIAMOND SCALES,
 Bullion Balances and
 Weights, in use at all the
 U. S. Mints and Assay
 Offices.
PRICED CATALOGUE ON APPLICATION.

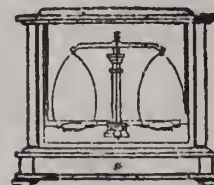

JNO. F. LUTHER,
79 Nassau Street, N. Y.
 Illustrated Catalogue sent on application.
 MANUFACTURER OF
 Masonic Jewelry.



PLATINUM

—FOR—

Scientific and Mechanical Purposes,

IMPORTED AND FOR SALE BY

The S. S. White Dental Manufacturing Co.

SCRAP PURCHASED.

PHILADELPHIA, Chestnut St., cor. Twelfth.
 NEW YORK, - 767 and 769 Broadway.
 BOSTON, - - - 160 Tremont Street.
 CHICAGO, - - 13 and 14 E. Madison St.

TO LET!

A Room 28½ x 14½, suitable for a

❖JEWELER'S OFFICE,❖

on the 2d Floor of the new

BRYANT BUILDING,

corner of Nassau and Liberty Sts.,
 New York.

C. KNAPP,
 Manufacturer of
 Superior Band
 and Children's
 Stone & Fancy
RINGS
 And Enameled Goods,
 41 Maiden Lane,
NEW YORK.



Solid Gold Rings a Specialty.
WM. H. ELY,
SOLID GOLD RINGS,
 MANUFACTURER.
 Viz., Plain, Chased, Engraved, Enameled,
 Engine Turned, Shield and Scale. All
 qualities guaranteed. Orders
 Promptly Executed.
 58 Nassau Street, New York.

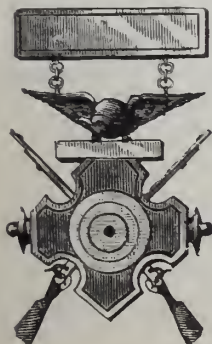

C. B. WILKINSON,
 Manufacturing ❖ Jeweler,
 S JOHN ST., N. Y.
 Medals, Badges and
 Masonic Jewelry
A SPECIALTY.
 Designs furnished free
 upon application.

HESS & SCHLIESSER,

IMPORTERS OF

DIAMONDS

AND JEWELRY.

Specialties:—Fine Novelties in French Goods,
 Gold and Blue Enamel Locketts, Charms,
 Crosses, Garnet and Silver Filigree Goods.

25 MAIDEN LANE, NEW YORK.

WM. RAWLINGS, JR.,
 Manufacturing ❖ Jeweler,

FACTORY:

913 Arch Street, Phila.

FINE GOLD RINGS A SPECIALTY

Goods sent on approval to any part of the
 country upon receipt of satisfactory reference.



HENRY LEFORT,
 Stem-Winding Watch Crown Manufacturer,
 Crowns and Pushers in gold, all sizes, quality and color,
 made to order. Silver crowns and pushers always on hand.
 60 Arlington Street,
 Corner William Street,
NEWARK, N. J.

We give **Special Attention** to effecting
 Settlements by **Compromise** between
 Debtor and Creditor.

COLLECTIONS.



BANKING AND COLLECTION HOUSE OF
HENRY McCABE & CO.,
 Principal Office:
 287 BROADWAY, Cor. Reade St.
 Attorneys and Correspondents at Every Point.

The Collection of Notes, Drafts, Current
 and Overdue Accounts made in all
 parts of the United States and
 Canada by our unrivaled system.

UNEXCEPTIONABLE REFERENCES AS TO
PROMPTNESS and RESPONSIBILITY.

P. JANDORF & BRO.,
Watches and Jewelry,

196 BROADWAY,

Bet. John & Fulton Sts., NEW YORK.

We Publish No Price Lists.

WATCHMAN'S IMPROVED TIME DETECTORS,

With Safety Lock Attachment.

U. S. Patents 1875-76-77-80-81-82.

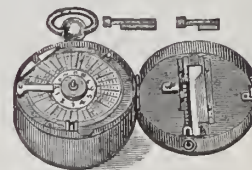

This instrument is supplied
 with 12 different keys for 12
 stations. It contains all
 Modern Improvements
 against the old style, and is
 the only
COMPLETE INSTRUMENT.

P. O. Box 2875.

E. IMHAUSER,
 212 Broadway, N. Y.

THE ACME OF PERFECTION.

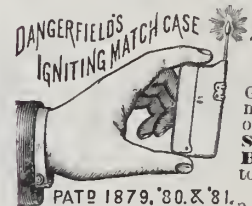

ALWAYS have on
 Sale this Celebrated
Match Case.

It has No EQUAL on the
 Globe. No Lady's or Gentle-
 man's outfit complete with-
 out one.

Solid Nickel Silver, 50c
Bronza Silver (equal
to Coin Silver, - - - - 75c

Samples or Goods sent pre-
 paid to any part of the world
 on receipt of price.

F. S. DANGERFIELD,
 Sole Mfr., Auburn, N. Y., U. S. A.
 Goods sold by First-Class Dealers everywhere.

The **Finest Line of High-Class English**
Watches in the U. S.

GEO. E. WILKINS,
SYRACUSE, N. Y.

Agent for the Celebrated Watches of

Chas. Frodsham & Co., London,
 W. G. Schoof, London,
 Karl Zimmerman, Liverpool.

Timing and Adjusting done for the Trade.

Correspondence Solicited from the Trade.

H. WASELL,

RUBBER STAMPS,
BRASS STAMPS,
 Brushes, Inks, &c.

Stencil Plates,

STEEL STAMPS.

Burning Brands,

SEALS & PRESSES,

No. 7 North William St.

First house South of East River Bridge, N. Y.

FINE STEEL STAMPS A SPECIALTY.

All parts furnished separately when desired. The Springs will never rust, and are much more durable than steel.



Please note a reduction of 50 cents per dozen on 286 and 288 Celluloid Eye-Glasses, No. 7 Catalogue.

The above cut represents a fine bust of Lord Byron, about twenty-five inches high, which will be furnished to parties purchasing 6 dozen Celluloid Eye-Glasses. It is securely packed, ready for shipment, and will make a very handsome ornament for the show window.

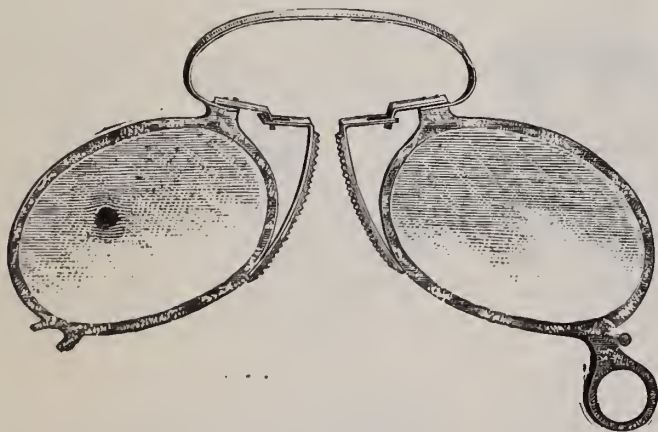

The above cut represents No. 306 Eye-Glass with an Adjustable Nose Piece, which we make in

Gold, Nickel, Celluloid, Rubber, Steel and Frameless.

This style of Eye-Glass is very popular. We make many NEW and EXCLUSIVE Styles that give a Dealer handling our goods an immense advantage over those who sell the ordinary line of goods in the market.

Special Goods, with Trade Mark, made for Dealers to Order.

Great Variety! Novel Styles! Attractive Goods!

While many houses have complained of dull trade this Spring, we have been increasing our force.

ACTIONS SPEAK PLAINER THAN WORDS.

Spencer Optical Manufacturing Co.,

13 MAIDEN LANE, NEW YORK.

Established 1853.

L. H. KELLER & CO.

Successors to G. A. HUGUENIN,

IMPORTERS OF

**WATCHMAKERS' and JEWELERS'
TOOLS AND MATERIALS.**

GENERAL AGENTS FOR

The Philadelphia Watch Company,

— AND —

American Watch Tool Co.,

MANUFACTURERS OF

THE WHITCOMB LATHE.

SOLE AGENTS IN THE UNITED STATES FOR THE SALE OF

**LUTZ'S
CELEBRATED ROLL HARDENED HAIR SPRINGS,
MOEBIUS OIL**

For Chronometers, Watches, Clocks, Telegraph Instruments and all other delicate machinery. Made from Pure Refined Neatsfoot Oil, and Warranted to Excel anything in the market as a Lubricator. **SAMPLES GRATIS.**

OUR OWN GRADUATED

AND JURGENSEN RECOILING MAINSPRINGS, pronounced by all experts Superior to all. Sold in Separate Strengths or Force.

Extra Fine Pinions cut from Solid Steel Wire. Gauged Hole Jewels of First-class Workmanship. A Full Line of Materials, for the PATEK, PHILIPPE & CO. GENEVA WATCHES, and all other Celebrated Makers.

THE BOLEY LATHES AND TOOLS,

Celebrated for their Practical, Substantial and Workmanlike Construction, Superior Design and Finish.

Our aim is to furnish nothing but First-class Serviceable Goods, especially manufactured for the Consumer, and not solely for the Market, like the cheap trash advertised in highly illustrated catalogues with which the country is flooded.

TREATISE ON MODERN HOROLOGY IN THEORY AND PRACTICE. By M. CLAUDIUS SAUNIER, Ex-Director of the School of Horology at Macon, France; Knight of the Legion of Honor, etc.; Hon. Sec. to the Paris Society of Horologists. Translated from the French by JULIEN TRIPPLIN, Besançon Watch Manufacturer, and EDWARD RIGG, M. A., Assayer in the Royal Mint, London.

This Work comprises 832 large octavo pages, with 78 wood cuts and 21 colored double-page copper-plate engravings. Bound in half calf, with an appropriate and handsome ornament in gold on front cover.

Price, \$15.00.

THE WATCHMAKER'S HAND BOOK. By the same author and translators. Intended as a companion to the Treatise. Bound in cloth.

PRICE, \$4.00.

64 Nassau Street,

NEAR MAIDEN LANE,

NEW YORK.

L. H. KELLER,
EDWARD HUNZIKER,
F. J. BOESSE.

We do not publish Price Lists.

SPECIAL NOTICES.

WANTED—A first-class watchmaker. Apply to Max L. Gutman, Rochester, N. Y.

FOR SALE—Jeweler's safe, with drawers and iron cash box, good order. H. Carter, 176 Broadway, New York City.

WANTED—A competent watchmaker and engraver. Must be temperate. Good reference required. Address L. K. L., care Jewelers' Circular.

WANTED—A good watchmaker that can engrave. Must come well recommended. State experience. Address Geo. W. Ludwig, Chambersburg, Pa.

FOR SALE—A retail jewelry store near this city. Good run of trade and a large line of work. Stock about \$3,000. Address E. Tillotson, 1269 Broadway, N. Y.

WANTED—A first-class watchmaker and engraver to go to the west. Must be a first-class man and furnish references. Address L., care Jewelers' Circular.

A GOOD CHANCE, for a jeweler with some means, to buy out a business in one of the most thriving towns in Michigan. Address Trier Bros., 15 Maiden Lane, N. Y.

SKILLED watchmaker, with one of the finest set of tools in U. S., wants an apprentice who can give security and work one year free of charge. Address Watchmaker, 70 N. 2d street, Phila.

WANTED—By a young man, a situation under a first-class watchmaker to finish his trade. Has had two years' experience. Can give good references. Address Sidney Smith, Lafayette, Sussex Co., N. J.

COMMERCIAL TRAVELER'S situation wanted by the undersigned. City and near by trade preferred. Address (care Jewelers' Circular) Wm. Jenilngs. Late with Messrs. Fitch & Harriman, to whom I refer.

WRITE TO W. F. A. WOODCOCK, Cumberland, Md., who is doing so much fine watch work for the trade, and see how quick you can get packages of work to and from him to your place. You will be astonished.

WANTED—A reliable and experienced travelling salesman to travel for a first-class jobbing house. One who is familiar with the jewelry trade in N. Y., Penn. and Ohio. Address A. and C., care Jewelers' Circular.

WANTED—A first class letter and monogram engraver, who can also do watch work. Can offer a good man a permanent place and good wages, in a healthy southern city. Address "Engraver," care Jewelers' Circular.

MOSELEY & CO., Elgin, Ill., manufacturers of the "Moseley" Lathe, with full line of fixtures and attachments. Designed especially for the watchmaker and repairer. Combining accuracy, durability, convenience and style.

WANTED—May 1st, a young man who has had two or three years' experience at the bench, to complete his trade. A good chance for the right man with references as to character and ability. Address Geo. E. Wilkins, Syracuse, N. Y.

WANTED—An experienced man by a diamond importing house. One who has an established trade on the road. State full particulars about previous employment, etc., which will be kept strictly confidential. Address Box 2405, P. O., New York.

FOR SALE—The stock and fixtures of an old established and first-class jewelry store in the city of Cohoes, N. Y. Population 20,000. Must be sold at once and will sell at a bargain. Satisfactory reasons for selling. Address W. D. McLean, Cohoes, N. Y.

A MANUFACTURING jeweler, having a patent on the process of manufacturing the Flush Rings, desires to increase his business by an agreement to manufacture some for some house using large quantities. Address Manufacturer, care Jewelers' Circular.

SITUATION wanted by a thorough, reliable and competent watchmaker, 10 years' experience in all kinds of work, 28 years of age and strictly temperate. Nothing but a good situation and good pay will be accepted. Address A. H. Sweet, care Jewelers' Circular.

FOR SALE—Jewelry store, stock tools and fixtures at cost, with good will. Stock, tools and fixtures about \$1,000. Good paying stand and good chance to increase business. No competition, population 3,000. Can rent store if parties wish. Address Isaac W. Reed, Sharon, Conn.

GEORGE E. WILKINS, manufacturer and importer of cutters for watchmakers' use, stem-winding cutters of all the different forms, rounding up cutters of the finest quality, also ratchet cutters. A large stock of second hand and new marine chronometers. No. 21 South Salina street, Syracuse, N. Y.

A FIRST-CLASS retail jewelry store, in a rapidly growing neighborhood in the immediate vicinity of New York City, for sale cheap. Business in a very prosperous condition. An excellent opportunity for a practical watchmaker with a few thousand dollars capital. Address C. E., care Jewelers' Circular.

FOR SALE—A first-class jewelry store in a growing town of 3,000 inhabitants in the State of Michigan. The business is in a good and flourishing condition, and stock is new and desirable, and is offered for sale because the owner is obliged to change location for reasons entirely independent of business. For particulars inquire of Oppenheimer Bros. & Voth, 35 Maiden Lane, New York.

FOR SALE—An old established jewelry store within 30 miles of New York. Stock and fixtures about \$15,000. Over \$20,000 business a year for past two years. Advertiser owns the premises and would give advantageous lease. Terms easy to responsible party. Address J. H. T., care Fellows & Co., 17 Maiden Lane, N. Y.

WE WANT—All jewelers and watchmakers to know that we manufacture the best and cheapest iron watch and spectacle signs in the world. All finished with the best XX gold leaf, and every one warranted. See illustrations on page 11, and be sure to ask for Grou's Excelsior signs. Excelsior Sign Co., Chicago.

WANTED—Situation as salesman and watchmaker, by a young man (Canadian). Have had sole charge of a branch store for nearly a year. Can furnish references from my present employer and others that must prove satisfactory. Strictly temperate. Present salary \$15 per week. W. C. Shaw, North Clarendon, Warren Co., Pa.

WATCH AND JEWELRY business for sale.—An excellent one for a good watchmaker. Stock new and clean, will invoice about \$2,100 including fixtures; work enough for two, no competition. Growing town, junction of four railroads. Rent low, gas and steam heat in store. Address Chas. M. Hoffman, Lock Box 6, White River Junction, Vt.

FOR SALE OR EXCHANGE—One of Bliss' best transits (cost \$125), is perfect and in good condition. Also one cutting engine, having two arbors and 24 cutters, well assorted and in good order. Part of cutters are improved kind, cutting and rounding up at same time. Both will be sold low for cash. Address Box 65, Kennett Square, Chester Co., Pa.

SHOW CASES FOR SALE—Handsome upright center show case on table, ebony and plate glass on all sides, nine feet long, eight feet high, suitable for an exhibition case or center of store. One black walnut wall case, eight feet long, nine feet high; one same pattern five feet long. Will be sold cheap for want of use. Address George H. Ford, New Haven, Conn.

WANTED—Every Jeweler to know that the Pike's Peak Mineral Clock is composed of from fifty to one hundred choice specimens of Gold and Silver Ores, Petrified Woods, Topazes, Agates, etc. Delivered to any express office in the U. S. for \$1.25 each, cash. Send all orders to C. W. Little, wholesale manufacturing and importing jeweler, 324 & 326 15th street, Denver, Col.

FOR SALE—An old established and well paying watch and jewelry business, with store and house for family to live in, in a town of Illinois; the only jeweler there, and the town is the county seat. Will sell store and house without stock, but should prefer to sell the whole. The reason for selling is: The desire to commence a larger business in a larger city. At least \$3,000 in money required. Address F. C. B., care Jewelers' Circular.

FOR SALE—The stock and fixtures of the leading jewelry store in an Iowa town of 8,000 inhabitants. Stock of watches, clocks, jewelry, silverware, and optical goods. Fixtures—fire and burglar proof safe, fine show cases, regulators, etc. All the work two men can do. Four railroads, coal mining and manufacturing. Doing paying business, but will sell at bargain in order to change climate, on account of asthma. Address M. T. W., care Jewelers' Circular.

FOR SALE—An old established jewelry store and loan office, in the best city in the south, 60,000 population, makes \$5,000 a year clear. You need not buy a dollar's worth of the stock, only the fire and burglar proof safe and fixtures, and pay bonus for the transfer of the pledges, which consist only of diamonds and gold and silver watches worth three times the amount advanced. The opportunity of a lifetime. The owner must take his family to Europe on account of ill health. Address immediately X. Y. Z., care Jewelers' Circular.

BUYERS' DIRECTORY.

NEW YORK.

Assayers and Sweep Smelters.

Wundoehl, H.—Gold and Silver Refiner, Assayer and Sweep Smelter. 21 John Street, N. Y.

Badges and Medals.

Stockwell & Newman—19 John Street. Manufacturers of Badges, Medals and Presentation Pieces in Gold and Silver. Also Jewelry and Mounters of Diamonds. Designs supplied.

Wilkinson, C. B.—Manufacturing Jeweler, 8 John Street, N. Y. Medals, Badges and Masonic Jewelry a Specialty. Designs furnished free upon application.

Band Rings.

Knapp, Charles, 41 Maiden Lane, N. Y. Specialty: Superior Band Rings, also Ring Shanks & Heads for Seal and Diamond Rings.

Bangles and Bangle Rings.

Harrison, Henry—Manufacturer of Gold Bangles and Bangle Rings. Also dealer in Watches and Jewelry. 66 Nassau Street, N. Y.

Black Onyx Jewelry.

Cox & Sedgwick—Manufacturers of Black Onyx Jewelry, No. 26 John St. New York.

Woglom & Miller—Manufacturers of (exclusively) Black Onyx Jewelry, 32 & 34 John St., N. Y.

Blue Enameled Locketts.

Bissinger, Philip & Co.—Importers of Diamonds, Pearls and Precious Stones. Agent for the Bohemian Garnet Goods. Blue Enameled Locketts. 22 John St., N. Y.

Hess & Schliesser—Importers of Diamonds, Fine Jewelry and Novelties in French Goods. Specialties: Gold and Blue Enameled Locketts, Charms and Crosses. 25 Maiden Lane.

Bohemian Garnet Jewelry.

Bissinger, Philip & Co.—Importers of Diamonds, Pearls and Precious Stones. Sole Agent for the Bohemian Garnet Jewelry. Blue Enameled Locketts. 22 John St.

Boxes, Wood Mailing and Nested.

Maine Manufacturing Co.—Successors to Swift M'fg Co., makers of Wood Mailing and Nested Boxes for Mailing and Express purposes. J. Spencer Taylor, Agent, 18 Courtlandt St., N. Y.

Wirsbauer, J.—Manufacturer of the Sliding Cover Wood Mailing Boxes. All Sizes Made to Order. Buffalo, N. Y.

Castings.

C. H. Leonhardt—Manufacturer of Fine Jewelry and Charms. All kinds of Moulding and Casting in Gold and Silver done for the Trade; largest assortment of Models. 65 and 67 Nassau Street.

Clock Companies.

Ansonia Clock Co.—Manufacturers of every description of Clocks. 11 to 21 Cliff street, New York.

Kroeber, F.—Manufacturer and Dealer in American and French Clocks, No. 8 Cortlandt Street.

New Haven Clock Co.—62 Reade Street, N. Y.

Seth Thomas Clock Co.—20 Murray Street, N. Y.

Waterbury Clock Co.—M. Bailey, Treasurer, Manufs and Jobbers, No. 4 Cortlandt St., N. Y., and No. 197 State Street, Chicago.

Wm. L. Gilbert Clock Co.—No. 6 Murray Street. Manufacturers of Clocks. Factories, Winsted, Conn.

Corals and Coral Jewelry.

Cuppia, L. A.—Importer of Coral and Silver Filigree Jewelry, 19 Union Square, N. Y.

Cameo Cutters, Etc.

Peiter, Theodore—Cameo and Intaglio Engraver. Patentee of the Cameo-Intaglio. No. 2 Bond Street, near Broadway, Room 4 New York.

Charms & Gold Watch Keys.

Rupp & Held—Manufacturing Jewelers, Charms and Gold Watch Keys, with French and English Ratchets, a specialty. 15 John St., N. Y.

Crucibles.

Berge, J. & H.—Established 1850, Manufacturers and Importers of Sand Crucibles, Covers, Chemical Porcelain, Glassware, and Jewelers' and Assayers' Supplies, 95 John Street, N. Y.

Berge, J. & Son.—Importers of Sand Crucibles and Covers, Jewelers' Tools and Materials. Manufacturers of Berge's Improved Assay and Enamel Furnace, Assay and Enamel Muffles, &c. 112 William St., N. Y.

Cutlery.

Harrison Bros. & Howson—Manufacturers of Fine Ivory and Pearl Table and Pocket Cutlery, Carvers in Cases; Nutpicks, Nutcracks and goods suitable for the jewelry trade. 126 Chambers Street. W. C. Burkinshaw, Sole Agent.

Diamond Brokers.

Anderson, Otis—Diamond Merchant and Broker, always ready to pay cash for bargains in Diamonds and Precious Stones, 4 & 6 John Street, N. Y.

Bernhardt, Richard—Diamond Broker and Importer, 65 Nassau Street (Room 6), N. Y. Paris, 20, rue des Petites-écuries.

Friend S. & Son—Brokers and dealers in Diamonds 33 John Street, cor. Nassau St. New York.

Herbert, R. J.—Diamond Broker and Dealer. 26 Maiden Lane.

Diamond Importers.

Bissinger, Philip & Co.—Importers of Diamonds, Pearls and Precious Stones. Agent for the Bohemian Garnet Goods. Blue Enameled Locketts. No. 22 John St., N. Y.

Bruhl, D. & M.—Established 1848. Importers of Diamonds and Precious Stones. 14 Maiden Lane, New York. Branch office, Paris. Also 111 Broad Street, Providence, R. I.

Brunswick, S. & Co.—Importers of Diamonds. 17 Maiden Lane, New York. Paris, Rue Lafayette. Amsterdam, Damsstraat.

Citroen, L. B., & Co.—Diamonds. 21 John St., N. Y. Cutting Works, 57 & 61 Rapenburgerstraat, Amsterdam. House in Paris, 44 Rue Laffitte.

Engelmann, M. & Co.—Importers of Diamonds, Pearls and Precious Stones. Specialties in Fine Colored Stones. 192 Broadway and 1 and 3 John Street, N. Y. Paris, 1 Boulevard St. Denis.

Faulkenau, Oppenheimer & Co.—Manufacturers. Diamonds and Diamond Jewelry. 40 Maiden Lane, N. Y.

Fera, Henry—Importer of Diamonds, and Manufacturer of Fine Diamond Jewelry. 4 & 6 John Street, New York. Amsterdam, Holland, 23 Loojersgracht.

Fox, M. & Co.—Importers of Diamonds, Rubies, Sapphires and Fancy Gems. No. 1 Maiden Lane, New York.

Hedges, Wm. S. & Co.—Importers of Diamonds, No. 170 Broadway, corner Maiden Lane.

Kuhn, Doerflinger, & Co.—Manufacturing Jewelers and Importers of Diamonds, 18 John Street, New York.

Neresheimer, E. Aug. & Co.—Importer of Diamonds. No. 21 Maiden Lane, New York.

Randel, Baremore & Billings—Importers of Diamonds, corner Maiden Lane and Nassau St.

Saunders & Ives.—Importers of Diamonds and other Precious Stones. No. 26 Maiden Lane.

Smith, Alfred H. & Co.—Importers of Diamonds, No. 182 Broadway.

Taylor & Brother.—Importers of Diamonds and Diamond Jewelry. 676 Broadway.

Wickham, D. H. & Co.—Importer of Diamonds. No. 31 Holborn Viaduct, London, 24 Maiden Lane, New York.

Wolff, G. A.—Importer of Diamonds, Rubies, Sapphires, Pearls, and other Precious Stones, 35 Maiden Lane, New York. 12 Rue de Chateaudun, Paris.

Diamond Jewelry.

Bernhard, A. & Co.—Importers of Diamonds and Manufacturers of First-Class Diamond Jewelry. Diamond Settings for Manufacturing Jewelers. Design Sheets for the Trade free of charge. 2 Maiden Lane, New York.

Bornemann, Louis.—Importer of Diamonds and Manufacturer of Rich Diamond Jewelry, 19 John Street, New York.

Chalumeau, D.—Diamond Jeweler and Manufacturer of Mountings. Novelties and Artistic Jewelry. No. 3 Maiden Lane, New York.

Hartje, G. & F.—Manufacturers of Diamond and Fine Jewelry, 860 Broadway, cor. 17th street, N. Y.

Heller & Bardel.—Manufacturers of Diamond and Pearl Jewelry, and Dealers in Diamonds, Pearls, &c. 13 John Street.

Jeanne Brothers.—Manufacturers of Diamond Mountings & Rich Jewelry. 1 Maiden Lane.

Lacroix & Verpillier.—Manufacturers of Fine Gold Jewelry. Diamonds a specialty. 173 Broadway, N. Y.

Schilling & Nissen.—Dealers in Diamonds and Diamond Jewelry. No. 51 Nassau Street, New York, near Maiden Lane.

Voelker, C. T.—Manufacturer of 18-k. Diamond Mountings, Diamond Jewelry and Roller Chain Bracelets. 189 Broadway, New York.

Waterman & Lehmann.—Manufacturing Jewelers and Dealers in Diamonds. Diamond Work, and Fine fancy Rings a specialty, any piece of single work made to order. 37 Maiden Lane, N. Y.

Diamond and Pearl Setter, &c.

Archibald, Wm.—Diamond Setter for the Trade. Cameos, Pearls, Turquoises, Garnets, Amethysts, Doublets, Foil Backs, white and colored, Imitation Stones. 73 Nassau Street, N. Y., room 7.

Diamond Cutters.

Hermann, I.—Importer of Diamonds and Precious Stones. Diamond Cutter and Polisher. Manufacturer of Diamond Jewelry. 19 East 15th Street, New York.

Levy, Herman.—Importer, Cutter and Polisher of Diamonds. 105 Fulton Street, New York.

Dials, &c.

Farnsworth, C. E. & Co.—Successors to Jno. T. Gold, Manufacturers and Jobbers in Fine Watch Dials. 81 Nassau St., N. Y.

New York Dial Co.—Manufacturers of Fine Watch Dials. Henry Abbott, Agent, No. 7 Maiden Lane, N. Y.

Enameled Clock Dials and Figures.

Caeser Bros.—Manufacturers of Enameled Clock Dials, also letters and numbers for signs. 230 and 232 East 25th Street, New York.

Enamelers, Etc.

Nutt, J. D.—Enameler on Gold, Silver, and Copper. Linen finished Buttons and Studs. Enameling in colors. 32 and 34 John Street, New York.

Orr, J. C.—Enameler on Fine Jewelry. Enameled in Colors. Linen Finished Buttons and Studs. Band Bracelets. No. 75 Nassau Street, N. Y.

Electroplaters, &c.

Jeandheur, F. & Son.—Gold and Silver Electro Platers & Fire Gilders, coloring Etruscan and Gold Jewelry a specialty. 125 Fulton St.

Engravers—Stone Seal, Etc.

Fackner, Edward—Carver, Engraver and Chaser on Jewelry and Pencil Cases, lettering, &c., 19 John Street.

Holland & Gosling—Stone Seal Engravers. Precious Stones inlaid and encrusted with Diamonds. No. 176 Broadway, New York, (fifth floor per elevator). Cameos cut and repaired.

Knapp, Chas. Engraver, Die Sinker & Stamper for Jewelry purposes. Ring Shanks & superior Band rings, 41 Maiden Lane, N. Y.

Meister, H.—Engraver and Chaser on Fine Jewelry, Badges, Monograms, Coats of Arms, etc.; also Enameling, Coloring and Polishing. No. 59 Nassau Street, New York.

Park, Wm.—The Stone Seal Engraver. Arms, Crests, Monograms, etc., engraved on precious stones, 26 John Street, New York.

Weston, James F.—Stone Seal Engraver and inlaid of Precious Stones. Coats of Arms, Masonic, Odd Fellows, and other devices engraved. 32 John Street.

Fancy Goods, Clocks, Bronzes, Etc.

Le Boutillier & Co.—Importers of Fancy Goods, Clocks, Bronzes, &c., 3 Union Square.

Taylor & Bro.—Importers of French Clocks, Bronzes, etc. 676 Broadway, N. Y.

Gold and Silver Cane Heads.

Simons, Bro. & Co.—Manufacturers of Gold Headed Canes, 611 and 613 Sansom street, Philadelphia.

Gold and Silver Plating, Etc.

Bantle, A.—Gold, Silver and Electro-Plating, 130 Fulton and 89 Nassau Streets, cor. Fulton Street, (Room 36,) N. Y. Watch Case Polishing.

Gold Band Bracelets.

Harrison, Henry.—Manufacturer of Gold Band and Buckle Bracelets. 66 Nassau Street, N. Y.

Gold Chains, Etc.

Beck, J. & Son, Manufacturers of Fine Gold Chains and Chain Bracelets, 10 Liberty Place, near Maiden Lane, N. Y.

Carter, Sloan & Co.—Manufacturers of Fine Gold Chain, Whiting Building, 4th St. and Broadway.

Dorrance, Edge & Co.—Manufacturers of the Celebrated Woven Fabric Gold Chain, No. 15 John Street.

Kaufmann Bros.—Manufacturers of Gold Chains, and Chain Bracelets, 26 John Street; Factory, 331 and 333 Bowery, N. Y.

Kohn, Alois & Co.—Manufacturers of Gold Chains. 9 Maiden Lane, N. Y.

Nordt, Charles.—Successor to Nordt & Schlag, manufacturer of Gold Chains and Chain Bracelets. Jobbing and Refilling Old Chains promptly attended to. No. 17 Maiden Lane, N. Y.

Saxton, Smith & Co.—Manufacturers of Fine Gold Chain, No. 14 John Street, N. Y.

Schlag, Chas.—Late Nordt & Schlag, Manufacturer of Gold Chains, Chain Bracelets, and Fine Jewelry, 177 Broadway, N. Y.

Smith, W. & Co.—Manufacturers of Gold and Silver Chains, Jewelry, etc. No. 25 Maiden Lane, N. Y.

Gold Goods.

Hale, S. W. & Co.—Manufacturers of Jewelry of Artistic Design. No. 694 Broadway, N. Y.

Gold Pens, Etc.

Aikin, Lambert & Co.—Manufacturers of Choice Gold Pens, Cases, Holders, Toothpicks, etc., 23 Maiden Lane, N. Y.

Faber, Eberhard.—Manufacturer of 16-karat Gold Pens and Pencil Cases, Nos. 718 and 720 Broadway, N. Y.

Fairchild, Leroy W.—Manufacturer of Gold Pens, Pencil Cases, Tooth Picks and Novelties in Charms. No. 18 John St., N. Y.

Johnson, E. S. & Co.—Manufacturers of Gold Pens, Pen Holders and Pencils. Cor. Maiden Lane and Nassau Street, New York.

Smith, H. M. & Co.—Manufacturers of Gold Pens and Holders, Tooth Picks, Pencils, etc. Sole Manufacturers of Sprague's Patent Gold Fountain Pen. Importers of Nickel and Silver Watches. 173 Broadway, New York.

Gold Rings.

Barnet Bros. & Powell—Manufacturers of Solid Gold Rings, 15 John Street, New York. Factory, Newark, N. J.

Bowden, J. B. & Co.—Manufacturing Jeweler.—Solid Gold Rings a specialty, 1 Maiden Lane.

Durlach, Henry—Manufacturing Jeweler. No. 75 & 77 Nassau St. Seal, Cameo, Amethyst and Garnet Rings a specialty.

Ely, W. H.—Manufacturer of Solid Gold Rings of every description. No. 58 Nassau Street.

Hildreth, H. P.—Manufacturer of Solid Gold Rings, Plain and Ornamental. No. 10 John St.

Kroll, H.—Manufacturing Jeweler. 78 Nassau Street, New York. Specialty: Solid Gold Stone Rings. All kinds of Fine Jewelry made to order, also Repairing for the Trade.

Peckham, Wm. H.—Manufacturers of Solid Gold Seamless Rings, and Fancy Embossed Rings, Patent Spectacles, Jewelry, etc. No. 4 Liberty Place N. Y.

Radler, K.—Manufacturing Jeweler. Gold Rings and Locketts a specialty. No. 39 Maiden Lane, New York.

Sauter, L.—No. 1 Maiden Lane, New York, Manufacturer of Stone Rings of every description, as Diamond, Cameo, Onyx Turquoise, etc., Scarf Pins, Scarf Rings, Studs and Buttons.

Schnurbusch, H.—Manufacturer of Solid Gold Rings. Specialty: Seal, Cameo, Pearl, Turquoise, Amethyst, Onyx and Garnet Rings. No. 3 Maiden Lane, N. Y.

Shafer & Douglass.—Manufacturers of all kinds of Seal, Stone, Turquoise, and fancy rings. No. 7 Maiden Lane, N. Y.

Sinnock & Sherrill.—Manufacturers of Stone Rings. No. 3 Maiden Lane, N. Y.

Thuerner & Church—Manufacturers of Fine Gold Rings. No. 9 Maiden Lane, N. Y.

Hair Jewelry.

Bernhard, A. & Co.—Manufacturers of Fine Hair Jewelry. Pattern Book of 2,700 designs free of charge to the First-class Trade. 2 Maiden Lane, New York.

Moutoux, Wm. E. & Co.—Manufacturers of Fine Hair Mountings in Gold. Grand catalogues for the trade. 81 Nassau St., Rooms 1 and 2. Finest work and lowest prices

Sauter, L.—Manufacturer of Fine Gold and Hair Jewelry and Device Work. Pattern Book sent on application. No. 1 Maiden Lane, N. Y.

Schwencke O.—Manufacturer of Fine Hair Jewelry Orders from the country promptly attended to. No. 43 Maiden Lane.

Jewelry Cases, Fancy Boxes, Etc.

American Morocco Case Co.—7 and 9 Bond St., N. Y., make a specialty of Rich Jewelry and Silverware Cases for the fine Retail Trade. Also Improved Trays for Watches, Rings, etc.

Braun, Chr. E.—Manufacturer of Fine Jewelry Boxes and Trays for Show Cases and Trunks. No. 62 Chatham Street, New York. Trays for Show Cases and Trunks a Specialty.

Bricka, C. A. & Co.—Manufacturers of Morocco Cases for Cutlery, Silverware, Jewelry, etc. Sample Cards and Rolls. Cases in Rosewood, Black Walnut, etc. 52 Nassau Street, New York.

Dennison Mfg Co.—Manufacturers of Morocco, Plush and Velvet Jewelry and Silverware cases. New York, Boston, Philadelphia, Chicago, Cincinnati and St. Louis.

Ettlinger, L. & Sons.—Manufacturers of Fine Cases for Jewelry, Watches and Silverware, Trays for Travelers and Show Cases. Cases to Order a Specialty. No. 80 Nassau St., N. Y.

Haensler, Chas. C.—Manufacturer of Fine Morocco Cases for Jewelry and Silverware. Toilet Boxes, etc. Trays for Show Cases and Windows. 14 John Street, New York.

Jackson, S. C., 180 Broadway, N. Y., Manufacturer of Fine Cases for Jewelry, Silverware, &c.

Kohn, Solomon & Co.—Manufacturers of Fine Morocco Cases for Jewelry, Watches, etc. 15 John Street, New York.

Kron & Krumpf—Manufacturers of Fine Morocco and Plush Cases for Watches, Jewelry, Silverware, etc. 169 William Street, Room 11, New York. Trays for Jewelers and Sample Trays for Travelers a specialty.

Lauten, Edw. A. & Co.—No. 4 Great Jones St., Manufacturers of fine Velvet, Brocade, Plush and Morocco Boxes, for Jewelry, Watches and Silverware, Patent Ring, Ear Ring and Gents' Scarf Pin Trays.

Loehr & Koerner—Manufacturers of Morocco, Velvet, Satin, Jewelry, Watches and Silverware Cases, Jewel, Work Boxes, etc., Fancy Trays and Store Fittings to order. 96 Liberty St.

Metropolitan Fancy Box and Leather Goods Manufactory—Makers of Plush, Velvet, Satin and Leather Cases for Watches, Jewelry, Silverware, etc. 75 and 77 Nassau Street, N. Y.

New York Morocco Case Co.—Cases for Jewelry, Watches, Silverware. Boxes and Trays for Jewelers' Travelers. Show Cases and Window Fittings. No. 69 Nassau Street, New York.

Schien, Charles E.—Manufacturer of Cases for Jewelry and Silverware, No. 85 Nassau St., N. Y. Show Case Trays, etc., at short notice.

Schwarz, N.—Manufacturer of fine Cases for Jewelry and Silverware, 866 Broadway, near 17th street, N. Y.

Steinle, E.—Manufacturer of Cases for Jewelry of all kinds. Also Cases for Mathematical and Surgical Instruments and for Trays for Travelers' Trunks, etc. 66 Nassau Street, N. Y.

Welch & Miller—Manufacturers of Morocco, Velvet, and Satin Jewelry Cases, Trays, &c., Telescope Sample Cases with flexible Trays. Complete stock on hand. 169 Broadway

Wiggers & Froelick—No. 60 Nassau street—Manufacturers of Cases for Jewelry, &c., of every description. Trays for Show-cases, Stands for Show-windows, etc.

Jewelers' Findings.

Dennison Mfg Co.—Paper Jewelry Boxes, cards, tags, pink and white cotton, etc. etc. New York, Boston, Chicago, Cincinnati, Philadelphia, St. Louis.

Ettlinger, L. & Sons.—Manufacturers of Jewelers' Paper Boxes and Findings. Morocco Paper, Satin or Plush Lined Wooden Corner Stops Jewelry and Silverware Boxes. 80 Nassau Street, New York.

Lehmann, Ludwig.—Manufacturer of Jewelers' Findings. Tags, Pink and White Cotton, and Tissue Paper. Specialty, Fine Paper Boxes for Jewelers and Silversmiths. 122 Fulton Street.

Valfer, S. & Co.—Manufacturers and Dealers in Jewelers' Boxes, Tags, Cards, Paper and Findings. Trays a specialty. Office and Salesroom, 66 Nassau street, New York.

Jewelry Manufacturers.

Aikin, Lambert & Co.—Manufacturers General stock of Reliable Jewelry, 23 Maiden Lane.

Alford, C. G. & Co.—Manufacturers. General line fine and Reliable Goods. Specialties in Onyx Goods and Chain. 200 Broadway, New York.

Baldwin, Sexton & Peterson—Makers of Fine Jewelry and Importers of Diamonds, etc., corner Broadway and Fourth Street.

Ball, W. H.—Manufacturer of Gold Jewelry. Bracelets and Bangles of all kinds a specialty. 9 John Street, N. Y.

Barthman, Straat & Co.—Manufacturers of Fine Jewelry. Roman Goods, Rings, Diamonds. No. 43 Maiden Lane.

Bernhard, A. & Co.—Manufacturers of General Fine Work. Specialties: Diamond Jewelry, Diamond Settings, Hair Jewelry, Fancy Rings, Rose Diamond Monogram and Onyx Work. 2 Maiden Lane, New York.

Brown, Thos. G. & Sons—Man'rs of Rich Jewelry Necklaces, Locketts, Bracelets, Sleeve Buttons, etc., 5 Bond Street, N. Y.

Bryant & Bentley—Manufacturing Jewelers. Rings a specialty. 12 Maiden Lane

Carter, Sloan & Co.—Manufacturing Jewelers Whiting Building, 4th St. and Broadway.

Champenois & Co.—No. 5 Maiden Lane, manufacturers of Engraved and Enameled Gold goods, in Sets, Ear Knobs, Bracelets, Studs, Lace and Shawl Pins, Jet cluster and Onyx goods, also "Best Lever" Sleeve Buttons.

Chatellier, Joseph F.—Manufacturing Jeweler, No. 694 Broadway, N. Y.

Churchill, Lewis & Co.—Manufacturers of Fine Jewelry. 692 Broadway, cor. Fourth St., N. Y.

Cook, Groeschel & Co.—Manufacturers of Fine Jewelry and Locketts, 191 Broadway (over Mercantile Bank,) N. Y.

Cottle S. Co.—Manufacturers of Fine Jewelry. Waltham Building, 5 Bond Street, N. Y.

Cox & Sedgwick—Manufacturers of fine Onyx and Colored Jewelry. 26 John St., New York

Day & Clark—Manufacturers of Fine Jewelry, Lace Pins, Ear Rings, Studs, Locketts, &c., 192 Broadway, cor. John St., New York.

Geoffroy, Arthur R. & Co.—Manufacturing Jewelers. Novelties in Diamond Goods. No. 23 Maiden Lane, N. Y.

Goddard, John M.—Manufacturing Jeweler,—Seal Rings and Fine Locketts a specialty, No. 3 Maiden Lane, N. Y.

Goldsmith & Cohen—Manufacturing Jewelers, 3 Maiden Lane, New York.

Greason J. R. & Co.—Successors to Arthur, Rumrill & Co., 182 Broadway. Manufacturers of Fine Jewelry and Gold Chains, also Diamond Mountings.

Greene Wm. C. & Co.—Goldsmiths; Manufacturers of Rich Sets in Taper Wire Coral. Office, 192 Broadway.

Hale, S. W. & Co.—Manufacturers Rich Jewelry, Whiting Building, Broadway and 4th Street.

Hartmann, P.—Manufacturer & Importer of Fine Gold, Diamond, and Filigree Silver Jewelry, No. 36 Maiden Lane. P. O. Box 2,454.

Haskell, H. C.—Manufacturing Jeweler. Seal Rings a specialty. Special attention to Jobbing of every description. 12 John street.

Hedges, A. J. & Co.—Manufacturing Jewelers, 6 Maiden Lane.

Henderson & Winter—Jewelers, No. 15 Maiden Lane, New York. Specialties—Stone, Cameo, Onyx, Amethyst, Topaz, Pearl and Turquoise Rings.

Hunt & Owen.—Manufacturing Jewelers. Office 3 Maiden Lane.

Kennedy, Frank S.—Manufacturer and Wholesale Dealer in Jewelry and Gold and Silver Thimbles. No. 13 Maiden Lane, New York.

Krementsz & Co.—Manufacturing Jewelers, No. 192 Broadway. N. Y.

Kuhn, Doerflinger & Co.—Manufacturers of Enameled and Roman Band Bracelets, also Fine Locketts Pendants and Lace Pins. 18 John street.

Lennon, John D.—Manufacturing Jeweler, 142 Fulton Street. Stone Locketts and Rings; also Badges and Emblems of all kinds.

Miller Bros.—Manufacturers of Fine Jewelry, Locketts, Sleeve Buttons, Studs, &c., 7 Maiden Lane, N. Y.

Moore & Horton.—11 Maiden Lane, Manufacturing Jewelers, Rings, Studs, Collars and Sleeve Buttons, Pins, Ear-rings, &c.

Muhr's, H., Sons.—Manufacturing Jewelers. Solid Gold and Filled Rings a specialty. Also Manufacturers of the celebrated Crown Filled Watch Case. 1½ Maiden Lane, N. Y.

Owen, G. & S. & Co.—Manufacturing Jewelers. Office, No. 3 Maiden Lane.

Richardson, Enos & Co.—Manufacturers of Fine Gold Jewelry, Gold Chains, Locketts, Crosses and Necklaces. Colored and Etruscan Work. No. 23 Maiden Lane, New York.

Richardson, J. W. & Co.—Manufacturers of Jewelry. Masonic and other Emblems. 196 Broadway, N. Y. Manufactory, Providence, R. I.

Riley, J. A. & Co.—Manufacturing Jewelers. Etruscan Gold and Roman Bracelets, Lace Pins, Ear Rings, Scarf Pins, Brooch Pins, etc. Nos. 7 and 9 Bond Street, N. Y.

Ripley, Howland & Co.—Manufacturers of Fine Jewelry and Platinum Tipped Diamond Settings. No. 17 Maiden Lane, N. Y.

Sauter, L.—Manufacturer of Fine Jewelry, Solid Stone Rings and Studs a specialty. Jobbing for the trade. 1 Maiden Lane, New York.

Sexton & Cole—Manufacturing Jewelers, Colored Gold and Onyx Goods a specialty. No. 30 Maiden Lane.

Shafer & Douglas, Manufacturing Jewelers—Roman Goods, Lace Pins, Cameo Sets, etc., Stone Rings, etc. No. 7 Maiden Lane, N. Y.

Sheafer, W. H. & Co.—Manufacturing Jewelers, Specialty Bangles and Bracelets, 15 John St., N. Y.

Steele, J. W.—Successor to Brainerd, Steele & Co., Manufacturer of Fine Jewelry and Brainerd's Patent Locketts. No. 9 Maiden Lane, N. Y.

Stites, D. H. & Son—Manufacturers of Fine Jewelry, Rolled Plated Goods and Chains, Parisian Diamond Rings, Studs and Earrings a specialty. 41 Maiden Lane, N. Y.

Stites' Sons, E.—Manufacturers of Fine Jewelry. No. 14 John Street, N. Y.

Street, Geo. O. & Sons.—Established 1837. Makers of Fine Jewelry, strictly first-class goods of our own make. No. 15 John Street, New York.

Terhune, Charles F.—Manufacturing Jeweler, 194 Broadway, N. Y.

Thoma, Ernest—Manufacturer of Fine Jewelry, Sleeve Buttons, Rings, Ear-rings, &c. No. 173 Broadway, N. Y. Factory, Ilackensack, N. I.

Unger Bros.—Makers of Fine Gold Jewelry, consisting of Lac Pins, Earrings, Collar Buttons, Band Rings White Enameled Studs, etc. Also Patent Onyx Brocelets, 9 Maiden Lane, N. Y.

Ward, Thos. M.—Manufacturer of Fine Jewelry, Diamond Mountings a specialty. No. 25 John Street, N. Y.

Wheeler, Parsons & Hays.—Manufacturers of Fine Jewelry, Watch Cases, Gold Chains, &c. and Dealer in American and Swiss Watches, No. 2 Maiden Lane, N. Y.

Wienhold, Joseph—Manufacturer of Fine Jewelry and Diamond Setter. 24 John St.

Woglom & Miller—Manufacturers of Black Onyx Goods exclusively. 32 & 34 John Street, N. Y.

Jewelry—Rolled Plate.

Frick, John & Co.—Fine Rolled Plate Jewelry of all kinds. Repairing of every description. 21 and 23 Maiden Lane, N. Y.

Mauran, J. T.—Manufacturer of Fine Rolled Plate Jewelry, No. 15 Maiden Lane, N. Y.

Richards, E. Ira & Co.—Manufacturers of Fine Rolled Plate Jewelry, No. 200 Broadway, N. Y.

Weil, Leopold & Co.—Manufacturers of Rolled Plate Jewelry of every description, 16 Maiden Lane, N. Y.

Jewelers' Tools, etc.

Fisher, James J.—Dealer in Watchmakers' and Jewelers' Materials, Files, Tools, Silk Guards, Spectacles, etc., 697 Broadway, N. Y.

Frasse & Co.—Importers of Stubb' French, Swiss, German and Sheffield Tools, Files and Steel Wire for Watchmakers, Jewelers, etc., 62 Chatham street, N. Y.

Friedenthal, A. & Co.—Importers and jobbers of Watchmakers' and Jewelers' Tools, Materials, etc. 43 Maiden Lane, N. Y.

Friedlander, R. & L.—264 Bowery—Importers of Watchmakers' tools and materials.

Kurtz, F. P.—Manufacturer of Jewelers Machinery, Tools, Rolling Mills, Presses, Polishing Lathes, &c. 97 Cliff St., N. Y.

Levy, Dreyfus & Co.—Importers and Jobbers of Watchmakers' and Jewelers tools and materials of every description. 11 Maiden Lane, N. Y.

Reichhelm & Koester.—Importers of Jewelers' Tools, Files, etc. Manufacturers of Brushes and Buffing wheels; also Patent Gas Furnaces for Melting, Plating, Enamelling, Annealing, etc. 80 Nassau St., N. Y.

Lapidaries.

- Fox, M. & Co.**—Practical Lapidaries, No. 1 Maiden Lane, New York.
- Graham & Co.**—Practical Lapidaries, Cutters and Polishers of all kinds of Precious Stones. Miners' Relics Cut, Polished and Mounted. Miniature, Locket and Clock Glasses. 80 Nassau St., N. Y.
- Kordmann & Michel.**—Lapidaries. Dealers in Precious Stones. Cutting and Polishing Rubies, Sapphires and other Gems a specialty. Drilling done promptly. 59 Nassau St., N. Y.

Masonic Jewelry.

- Lennon, John D.**—Manufacturer of Masonic, Odd Fellows, Athletic Clubs and other Jewelry, No. 142 Fulton Street, New York.
- Luther, John F.**—79 Nassau Street. Manufacturer of Fine Presentation Jewels for all Societies. Knights Templars, Crosses, Badges, &c.
- Popper, H.**—Manufacturer of Medals and Badges for Military, G. A. R., Shooting, Masonic, Odd Fellows, Knights of Pythias, etc. 91 Essex St., New York.
- Wilkinson, C. B.**—Manufacturing Jeweler, 8 John St., N. Y. Medals, Badges and Masonic Jewelry, a specialty. Designs furnished free upon application.

Optical Goods.

- Friedlander, R. & L.**—264 Bowery. Dealers in Optical Goods.

Opticians.

- Burbank Manf'g Co.**—Manufacturers of Spectacles and Eye Glasses of all descriptions, in gold, silver, etc., 14 Maiden Lane, N. Y.
- DuBois, Geo. W. & Co.**—Importers of Watches and Optical Goods. 36 Maiden Lane, N. Y.
- Kahn, Hanover & Co.**—Importers of Spectacles, Eye-Glasses and Optical Goods generally, and Scientific Instruments of every description. 32 Maiden Lane, New York.
- Laurencott, J. B.**—Importer of Watch Glasses, Optical and Fancy Goods, Clocks, Bronzes, etc., 33 Maiden Lane, N. Y.
- Levy, Dreyfus & Co.**—Importers of Spectacles and Eye Glasses and Optical Instruments of every description, No. 11 Maiden Lane, N. Y.
- Lorsch, Albert**—Manufacturer of the Patent Accommodating Spectacles and Eye Glasses in Gold, Silver and Steel, and other Optical Goods, 37 Maiden Lane, N. Y.
- Major, W. E.**—Importer of Optical and Fancy Goods, Spectacles, Eye-Glasses, Silk Guards, Opera Glasses, Field Glasses, Telescopes, Etc. Also Dealer in Chains and Jewelers' Findings. No. 42 Maiden Lane, New York.
- New York Optical Co.**—Manufacturers of Spectacles, Eye-Glasses and Cases, No. 43 Maiden Lane, New York. (P. O. Box 2309).
- Spencer Optical Manufacturing Co.**—Gold, Silver, Steel, Nickel and Plated Spectacles; Gold, Celluloid, Steel, Nickel and Rubber Eye Glass and Opera Glasses. 13 Maiden Lane, N. Y.

Precious Stones, &c.

- Bishop, Victor & Co.**—33 Maiden Lane, Importers of Precious Stones, Cameos, &c. Also Manufacturers of Coral Jewelry.
- Bissinger, Philip & Co.**—Importer of Diamonds, Pearls and Precious Stones. Agent for the Bohemian Garnet Goods. Blue Enameled Locket. No. 22 John St., N. Y.
- Breidenbach, R. A.**—Importer of Black Onyx, Cameos, Turquoise, Pearls, Sardonyx, Amethysts, Topaz, Garnets, Opals, Rubies, Sapphires, Cat's Eyes, Hematites, Brilliants, Doublets, etc. 85 Nassau St., N. Y.
- Daue, Wm. & Co.**—Importer of Precious and Imitation Stones. No. 202 Broadway New York.
- Fox, M. & Co.**—Importers of Diamonds and other Precious Stones, No. 1 Maiden Lane, N. Y.
- Gruet, Jules.**—Importer of all Grades of Real and Imitation Stones. 14 John St., N. Y.
- Guntzburger Bros.**—Manufacturers and importers of Precious Stones—Amethysts, Topaz, Cameos, Garnets, Imitation Diamonds, &c. No. 9 Maiden Lane.
- Hahn & Co.**—Importers of Precious Stones. Cameos, Onyx, Pearls, Intaglios, Amethysts, Garnets, etc. 64 Nassau Street, New York.
- Kahn, L. & M.**—Importers of precious and imitation stones. 10 Maiden Lane, N. Y.

Kipling, E. E.—Importer of Precious and Imitation Stones. Manufacturer of the Patent Foil Solid Metal Back Rhine Stone Brilliant. No. 6 Maiden Lane, N. Y.

Kipling, R. A.—Precious and Imitation Stones, No. 24 Maiden Lane, N. Y. Manufacturer Cameos, Agates, Onyx, Etc. Oberstein, Germany. Commission Merchant, 49 Rue De L'Echiquier, Paris.

Tannenbaum, L. & Co.—Importers of Diamonds and Precious Stones. Steam Lapidary Works. Oriental Stones Cut and Polished a specialty. 65 Nassau St., N. Y.

Silverware.

- Gorham Manufacturing Co.**—Union Square.
- Knowles, J. P. & S. M.**—Manufacturers of Sterling Silverware, 20 Maiden Lane, N. Y. Factory, Providence, R. I.
- Shiebler, Geo. W.**—Manufacturer of Sterling Silverware. No. 8 Liberty Place, near Maiden Lane, N. Y.
- Wood & Hughes.**—Manufacturers of Fine Silverware. 16 John Street, N. Y.
- Whiting Manufacturing Co.**—Makers of Sterling Silver Ware. Broadway cor. 4th Street, N. Y.

Silver Filigree Jewelry.

- Cuppia, L. A.**—Manufacturer of Solid Silver Novelties, and Importer of Silver Filigree, 19 Union Square.
- Hartmann, P.**—Manufacturer of Silver Filigree Jewelry. 36 Maiden Lane, N. Y.

Silver Plated Ware.

- Holmes, Booth & Haydens**—Manufacturers of Silver-Plated Ware. 47 Chambers Street.
- Manhattan Silver Plate Co.**—Manufacturers of Silver Plated Ware. Showrooms, 23 John St. Factory, 301 to 305 East 22d St., cor. 2d Ave. Address all communications to Factory.
- Meriden Britannia Co.**—Manufacturers of Silver-Plated Ware. 46 East 14th Street, Union Square.
- Meriden Silver Plate Co.**—Manufacturers of Fine Silver Plated Ware. No. 30 E. 14th Street, New York.
- Middletown Plate Co.**—Manufacturers of Superior Electro-Plate. Factories, Middletown, Conn., salesroom, 13 John Street.
- Rogers & Bro.**—Manufacturers of the finest quality of Electro-Plated Ware. 690 Broadway.
- Rogers, Smith & Co.**—Manufacturers of Fine Electro Plated Ware. No. 46 E. 14th St., N. Y.
- Simpson, Hall, Miller & Co.**—Manufacturers of fine Silver-Plated Ware. No. 36 E. 14th Street.
- Schade, Henry.**—Manufacturer of White Metal and Plated Ware. No. 84 John St., N. Y. Price list and catalogue furnished on application.
- Webster, E. G. & Bro.**—Manufacturers of Fine Silver-Plated Ware. Office and warerooms, 14 Maiden Lane, N. Y.

Show Cases, Etc.

- Smith, B. & W. B.**—Manufacturers of Patent Improved Dust Proof Show Cases, with Perpendicular Sliding Doors. No. 220 W. 29th St., N. Y.

Spectacle Case Manufacturers.

- Bertine, P. D.**—Manufacturer of Spectacle Cases, 139 William Street, near Fulton St., New York.
- Koenen, A. & Bro.**—Manufacturers of Leather Spectacle and Eye-Glass Cases. 81 Nassau St., N. Y.

Stem Winding Attachments.

- Abbott, Henry** Maker of Stem Winding Attachments, No. 7 Maiden Lane, N. Y.

Thermometers, Etc.

- Tagliabue, Giuseppe.**—manufacturer of Thermometers, Barometers and Hydrometers. Patentee and sole manufacturer of the U. S. Standard Hydrometer. 302 Pearl Street, near Beekman.

Thimble Manufacturers.

- Barker Manuf'g Co.**—Makers of Patent Graduated Thimbles, Stiffened Gold, Filled Gold and Rolled Gold, 36 Maiden Lane, N. Y. A. Lyons, Ag't. Factory, 129 Eddy St., Providence, R. I.
- Burbank Manuf'g Co.**—Manufacturers of Gold and Silver Thimbles, 14 Maiden Lane, N. Y.
- Ketcham & McDougall.**—Improved Gold and Silver Thimbles, Nos. 4 and 6 Liberty Place, near Maiden Lane, N. Y.

Simons Bro. & Co.—Manufacturers of Gold and Silver Thimbles, 611 and 613 Sansom Street, Philadelphia.

Woglom & Miller.—Sole Agents for the "Prime" Thimbles in Gold and Silver, manufactured by Ezra C. Prime. 34 John Street, N. Y.

Watch Companies.

- American Watch Co.**—Robbins & Appleton, No. 5 Bond Street, N. Y.
- The E. Howard Watch and Clock Co.**—Cor. Maiden Lane and Nassau Street, N. Y.
- Waterbury Watch Co.**—Manufacturers of the Waterbury Watch. Factory, Waterbury. Office, 4 Maiden Lane, N. Y.

Watch and Chronometer Jeweler.

- Queen, James.**—Watch and Chronometer Jeweler and Pallet Maker, 78 Nassau Street, room 8. Pivots inserted in Pivots, Balance, Staffs, etc.
- Wennstrom, John.**—Watch, Chronometer and Clock Jeweling, Jewel Gauges, Ruby and Sapphire Draw Plates; Diamonds Dressed; Polishing Stones for Jewel Settings. 2 Dutch St., N. Y.

Watch Importers, Etc.

- Abry, Chas. Leo**—Importer and Manufacturer of Swiss Watches of all grades. 63 Nassau Street.
- Aikin, Lambert & Co.**—Importers of Watches. Sole Agents for Paul Breton & Chas. Latour, Geneva. A general line of reliable Swiss Watches, Watch Cases, etc. 23 Maiden Lane, N. Y.
- Bartens & Rice**—20 John Street, Importers of Watches and sole agents in the United States for the celebrated Nicole, Nielsen & Co. Watches.
- Cross & Beguelin.**—Importers of Watches, Watch Tools and Materials, dealers in American Watches, No. 21 Maiden Lane, N. Y.
- Droz, Henry E.**—Importer of Watches, and Watch Case Manufacturer. Agent for the "E. Perregaux" Watch, and jobber in American Watches. No. 92 Fulton Street, N. Y.
- Durfey & Reynolds**—Successors to Durfey & Shiebler, Watches, Diamonds, Jewelry. No. 9 John Street, (up-stairs) New York.
- Freund Max & Co.**—Importers of Watches, Jewelry and Precious Stones, 8 Maiden Lane, N. Y.
- Gagnebin, Chas.**—Importer of all kinds of Swiss, and Dealer in American Watches. 4 Maiden Lane, N. Y. Agent for Ulysse Breting's Fine Chronometers, Chronographs, Anchors, &c
- Gallet, Julien.**—Importer of Watches. No. 1 Maiden Lane.
- Ginzel, Henry**—Importer of Watches, Tools and Materials, 31 Maiden Lane, N. Y. P. O. Box 2967
- Heinrich, H. H. & Co.**—Sole Agents for the Karl Zimmerman Watch, and Importers of Fine Watches and Marine Chronometers. 12 John Street, N. Y.
- Herzog, Louis & Co.**—Importers of Watches, Dealers in Diamonds and Jewelry, 52 Maiden Lane, N. Y.
- Hirsch Bros.**—Dealers in Watches and Diamonds and Manufacturers of Jewelry, No. 23 Maiden Lane, N. Y.
- Hyde's Sons, John E.**—Wholesale Commission Agents, only for Jules Jurgensen, of Copenhagen; Jules Monard, of Geneva; and for other makers of all qualities of Watches, 22 Maiden Lane.
- Jandorf, P. & Bro.**—Importers of Watches and Jewelry, 196 Broadway.
- Keller, L. H. & Co.**—Successors to G. A. Huguenin, Importers of Fine Watch and French Clock Materials, No. 64 Nassau Street, N. Y.
- Mathey Bros. & Mathez.**—Importers of Fine Watches and Sole Agents for the H. L. Matile's Watches. No. 16 Maiden Lane.
- Oppenheimer Bros. & Veith.**—Dealers in Watches and Diamonds, and Manufacturing Jewelers, No. 35 Maiden Lane.
- Robert, J. Eugene**—No. 30 Maiden Lane, New York. Agent for Louis Audemar's celebrated watches.
- Schwob, Adolphe**—Manufacturer and Importer of Watches, 11 Maiden Lane, N. Y.
- Stern Brothers & Co.**—Importers of Swiss Watches and wholesale dealers in American Watches, &c., 39 Maiden Lane.
- Soott, J. T. & Co.**—Importers of Watches, and Manufacturers of Jewelry, and Jobbers of all Grades of American Watches, 11 Maiden Lane.
- Strasburger, Louis & Co.**—Importers and Makers of Watches of every description, 15 Maiden Lane.

Watch Cases.

- Brown, J. A. & Co.**—Manufacturers of the Ladd Patent Stiffened Gold Watch Cases, etc., 11 Maiden Lane, N. Y. Factory, 58 Eddy Street, Providence, R. I.
- Dueber Watch Case Mfg Co.**—Manufacturers of Gold and Silver Watch Cases. No. 16 Maiden Lane, N. Y. Factory, Newport, Ky.
- Fahys, Joseph**—Manufacturer of Watch Cases and Dealer in American Movements, 38 Maiden Lane.
- Hagstoz & Thorpe**—Manufacturers of Boss' Patent Gold and Keystone Silver Cases. 14 John Street, New York.
- Keller & Untermeyer**—Manufacturers of Watch Cases with Raised Gold Ornaments. 9 Maiden Lane, N. Y.
- Willemin Watch Case Co.**—Makers of Gold Watch Cases. Raised Gold Ornamentation and Jurgensen style of Engine Turning. 109 Sands Street, Brooklyn, N. Y.

Watch and Chronometer Repairers.

- Cerf, B.**—Practical Watchmaker and Repairer, No. 10 John Street, N. Y. Repairing and adjusting of Fine Watches done for the trade. All kinds of escape and stem-winding wheels cut to order.
- Heinrich, H. H. & Co.**—Sole Manufacturers of H. H. Heinrich's Patent Auxiliary Balance, and Adjusters and Repairers of Fine Watches and Chronometers. 12 John Street, N. Y.
- Lesperance, Theo.**—Watchmaker and Wheel Cutter. Also Stoning Nickel Movements. No. 1 Maiden Lane, New York. With Julien Gallet.
- Ludeman, W. H.**—Chronometer and Watch Maker. Repairing of every description for the trade, 75 and 77 Nassau Street.

Watch Case Repairers.

- Feinier, Joseph A.**—Watch Case Maker and General Repairer. Specialty in fine Gold and Silver Cases. Jobbing promptly attended to. Nos. 4 and 6 John St., N. Y.
- Tarbox, Hiram**—Watch Case Repairing, Springing, Polishing and Engine Turning. 1874 North Fourth Ave., bet. 176th and 177th Sts., N. Y.

Watch Glasses, Shades, Etc.

- Brown, Edwin H.**—No. 85 Nassau Street, Imported and Own Manufacture Watch Glasses, Flat, Flat Concave, Concave, Convex and fine Geneva's. Fine fitting solicited.

Watches, Jewelry, etc.

- Cohn, J. J.**—Importer and Manufacturer of Whitby Jet, Rubber and Pearl goods. Gold and Rolled-plate Jewelry, etc. 12 Maiden Lane, New York.
- Friedman, Saml.**—Wholesale Dealer in Watches and Jewelry, 42 Maiden Lane, N. Y.
- Fry & Schieber**—Manufacturers of Fine Gold and Plated Jewelry and Importers of Watches, 201 Broadway, N. Y.
- Lieberthson, L. M.**—Importer of diamonds and watches. Manufacturer of jewelry. 14 John St. Fine stones a specialty.
- Lissauer & Sondheim**—Wholesale Jewelers and Jobbers in American Watches, No. 12 Maiden Lane, N. Y.
- Marx, Kossuth & Co.**—Importers of Watches and Dealers in Jewelry. 39 Maiden Lane, N. Y.
- Mayer, B.**—Manufacturer of Fine Jewelry, and Dealer in Watches, 71 Nassau street, cor. John street, New York.
- Mayer, Max.**—Dealer in Gold and Fine Rolled Plate Jewelry of every description. 71 Nassau St., N. Y.
- Myers, S. F. & Co.**—Manufacturing and Wholesale Jewelers—all grades. Importers of Watches. Illustrated Catalogue to the trade. 179 Broadway, N. Y.
- Stern & Stern**—Dealers in Watches, Jewelry and Diamonds. No. 6 Maiden Lane, N. Y.
- Strauss, Jacob.**—Full Line of Gold and Plated Jewelry, and Importer of Watches. 18 John Street, New York.
- Thrall, E. A.**—Wholesale Dealer in Watches and Jewelry. No. 1 Maiden Lane, N. Y.
- Trier Bros.**—Importers of Garnet, Whitby Jet and Amber Jewelry, Silk Guards, Opera, Field and Marine Glasses, Pearl Card Cases. Also a full line of Gold and Plated Jewelry. 15 Maiden Lane, N. Y.

White, N. H.—Jobber in American Waltham Watches and Chronographs. Waltham make of 14-k. and 18-k. Gold and Sterling Silver Cases. Filled 10-k. and cheap Gold Cases. 11 Maiden Lane, N. Y.

Watch Tools, etc.

- Gesswein, F. W.**—Manufacturer of Machinery and Tools for Jewelers, Watch, Clock and Watch Case Makers, etc. 39 John Street, N. Y.
- Keller, L. H. & Co.**—Importers of Watchmakers' and Jewelers' Tools, Materials, etc. 64 Nassau Street, N. Y.
- Zimmern, Henry**—Importer of Watch Materials, Tools, and Optical Goods, No. 8 Maiden Lane, (first floor.) Sole Agent for A. Hugenin & Gravier, Mainsprings, New York.

PHILADELPHIA

- Booz & Co.**—Manufacturers of Gold and Silver Watch Cases and Jewelry, 108 South 8th St., Philadelphia.
- Bennett, Jacob & Son**—Diamond Setters and Manufacturing Jewelers, 925 Chestnut St.
- Bernard & Co.**—Manufacturers of fine Roman and Etruscan Jewelry. Designs of every description made to order, 123 & 125 South Eleventh Street, Philadelphia.
- Birmingham, Wm. & Co.**—Morocco Case Manufacturers. Spectacle and Eye-Glass Cases a specialty, 626 Arch Street, Philadelphia, Pa.
- Clark, J. L.**—Gold and Silver Refiner and Assayer; Sweep Smelter. Gold and Silver or Platinum bought. 823 Filbert Street, Philadelphia.
- Conover David F. & Co.**—American Watches, Wholesale Salesroom, Southeast corner 7th and Chestnut Streets, Philadelphia.
- Dubosq, J. Carrow**—Manufacturer of Fine Jewelry. Particular attention given to repairing Strung Pearl work. 108 South Eighth St., Phila.
- Fick, Chas. M.**—Stone Seal Engraver. Coats of Arms, Crests, Monograms, Initial Letters and Masonic Emblems, and other devices engraved on all kinds of Precious Stones. Cameos cut and repaired. 618 Chestnut Street.
- Goldsmith, M. I.**—Importer and jobber of Watch Materials, Tools, etc. 722 Chestnut St., Philadelphia, Pa.
- Guilbert, Thos. M., & Co.**—Manufacturing Jewelers. Flexible Bracelets and Strung Pearl Repairing. 908 Chestnut St., Philadelphia.
- Hagstoz & Thorpe**—Manufacturers of Boss' Patent Gold and Keystone Silver Cases. 19th and Brown Streets, Phila. New York office, 14 John St.
- Herold, Chas P.**—Successor to Hildebrandt, Herold & Co., Manufacturing Jeweler and Diamond Setter. Diamonds. 916 Chestnut Street.
- Krieder, Peter L.**—Manufacturer of Sterling Silver Ware. 618 Chestnut Street, Philadelphia.
- McCarty & Hurlburt**—Manufacturers of Gold Spectacles, Silver Thimbles and Plain Rings. Wholesale dealers in American Watches, Jewelry, etc. 131 North Second Street.
- Morgan & Headly.**—Manufacturing Jewelers, Cameo Sets, Gold Sets, Roman Locketts, Rings, Coral Sets and a general line of rich goods. Corner 10th and Chestnut Streets, Philadelphia.
- Morgan, Charles V.**—Manufacturer of Morocco and Hardwood Cases. 550 Chestnut Street, Philadelphia. Jewelry and Silverware Cases, Show Case Trays, Mathematical and Surgical Instrument Cases, etc.
- Morris, William**—Importer of Watch Materials, Tools, Glasses, Spectacles, White Metal and Plated Chains. The attention of the closest buyers is requested. 706 Chestnut St., Philadelphia.
- Muhr's, H. Sons.**—Manufacturing Jewelers. Solid Gold and Filled Rings a specialty. 633 and 635 Chestnut Street, Philadelphia. 1½ Maiden Lane, New York.
- Peters, Reese S.**—Manufacturer of Patent Rolled Plate or Filled Watch Cases, Dealer in American Movements, 308 Chestnut Street, Philadelphia.
- Robeth, A.**—Wholesale Optician, and Dealer in Fine and Plated Jewelry, also Diamonds and Swiss Watches. 825 Market St., Philadelphia.

Rowe, Geo. A.—Stone and Metal Seal Engraver, Die Sinker and Medalist, Intaglio Cutting. Special rates for large quantities to manufacturers. 1002 Walnut Street.

Rosenthal, G. F. C.—Manufacturing Jeweler and Diamond Setter. Engraving and Designing of Monograms a Specialty. No. 917 Sansom Street.

Scherr, L. A. & Co.—Wholesale Dealers in Watches Silver-Plated Ware, Spectacles, Fancy Goods, Watch Materials, etc. 726 Chestnut Street.

Sheafer, W. H. & Co.—Manufacturing Jewelers. Specialty: Band Bracelets. Factory, 612 and 614 Chestnut street, Philadelphia. Office, 15 John street, New York.

Simons, Brother & Co.—Manufacturers of Fine Jewelry, Canes, Thimbles, Chains. 611 and 613 Sansom Street.

Vansant, John T. & Co.—611 and 613 Sansom Street, Artisan Hall, Manufacturers and Wholesale Dealers in English Sterling Silverware. Specialties: Tea Sets, Knives, Forks, Spoons, Cups and Napkin Rings.

CHICAGO.

- American Watch Company**,—of Waltham, Mass. No. 170 State Street, Chicago.
- Chicago Watch Case Co.**—Manufacturers of Patent Dust Proof Screw Bezel Watch Cases. Cor. Madison Street and Michigan Avenue, Chicago, Ills.
- Clapp, Caleb & Co.**—Wholesale Jewelers, 63 and 65 Washington Street. Catalogue and price list issued to watchmakers and jewelers.
- Cogswell & Wallis, Ag't**—Dealers in Clocks, Watches, Jewelry, Silver and Plated Ware, Watch Tools, Materials and Optical Goods, 146 State Street, Chicago.
- Dennison Manufacturing Co.**—Manufacturers of Jewelers' Paper Boxes, Morocco Cases, Tags, Cards, Pink and White Cotton, Tissue Papers, Sealing Wax, &c., &c., 102 Madison St., Chicago. Boston, New York, St. Louis, and Philadelphia.
- Excelsior Sign Co.**—Manufacturers of (Grout's Excelsior) Iron Watch and Spectacle Signs. 124 Fifth Avenue, Chicago, Ills.
- Gilbert, Wm. L., Clock Co.**—Manufacturers of Clocks, Regulators, and Time Pieces, and Clock Material of every description, 54 and 56 Madison Street, Chicago.
- Giles, Bro. & Co.**—Manufacturers and Jobbers in Watches, all classes of Jewelry, Materials, Clocks, Silver Ware, &c. Illustrated catalogues furnished to dealers on application. State and Washington Streets.
- Hagstoz & Thorpe**—Manufacturers of Boss' Patent Gold and Keystone Silver Cases. H. M. CARLE, Agent, 67 Washington St.
- Kearney, Theodore**—133 and 135 State Street. Importer and Jobber of Watchmakers' and Jewelers' Supplies, Watches, Jewelry, etc. Illustrated catalogue and price list sent on application and receipt of card.
- Stein & Ellbogen**—Wholesale Dealers in Watches and Jewelry, 127 State Street, Chicago, Ill. Specialty, repairing for the trade.
- Wathier, Joseph P.**—Watchmakers and Jewelers for the trade, and Wholesale Dealers in Watch Materials, Tools, etc. 178 West Madison Street, Chicago, Ill. Send for price list.
- Welch, E. N. Mfg. Co.**—6 Warren Street, New York, E. C. Hine, Treasurer and General Manager, 69 Washington Street, Chicago. F. E. Morse, Agt.
- Wendell, Charles & Son**—Wholesale Watches, Jewelry, etc. 170 State street, Chicago.

NEWARK.

- Alling, Isaac A. & Co.**—Manufacturers of Diamond and Fine Gold Jewelry, Sets, Lace Pins, Ear Rings, Studs, Rings and Buttons. Specialties: Wire Bracelets, Bangles and Scarf Pins. 50 Walnut Street, Newark.
- Baker & Co.**—Gold and Silver Refiners, Assayers and Sweep Smelters. 408 New Jersey Railroad Avenue, cor. Murray St., Newark, N. J.

Diefenthaler Bros. & O'Donnell—Manufacturers of Fine Jewelry, Lace Pins, Ear Rings and Patent Spring Bangles a Specialty. 36 Crawford Street, Newark, N. J.

Felger, F. & F.—Manufacturing Jewelers. Specialties:—Roman Band Bracelets, Lace Pins, Scarf Pins, Ball and Fancy Ear Rings. No. 477 Washington Street, Newark, N. J.

Fiedler, Herrman—Successor to Kunze & Fiedler, Engraver, Die Sinker and Press Tool Maker, 363 Market Street, Opposite Pennsylvania R. R. Depot, Newark, N. J.

Hopper & Valentine—Manufacturers of Fine Jewelry, No. 8 Maple Place, Rear 44 Green St., Newark, N. J.

Huger & Heitlinger—Manufacturers to the Jobbing Trade only. Makers of Roman Stone, Engraved and Enameled Lockets, also Sets, Lace Pins and Ear Rings. Rear 477 Washington St.

Krippendorf, C. & Schuller, F.—Machinists and Jewelers' Tool Makers. 19 Greene Street, Newark, N. J. Rolls, Dies, Cutters, and Draw-plates of every Description made and repaired.

Lefort, Henry.—Stem-winding Watch Crown Manufacturer. 60 Arlington Street.

Lelong, L. & Bro.—Gold and Silver Refiners Assayers and Sweep Smelters, Southwest corner of Halsey and Marshall Streets, Newark, N. J.

Miller & Beam—Manufacturers of Enameled Sets, Ear Rings, Lace Pins, etc. Guard Slides and Pendants a Specialty. 21 and 23 Green Street.

Milne, Alex.—Manufacturer of Stem-winding Watch Crowns. 19 Ward Street.

Plumb & Marcus—Manufacturers of Traveling and Marine Clocks, Electric Appliances. 289 Washington St., Newark, N. J.

Pollock, T. H.—Manufacturer of Jewelers' and Silversmiths' Wheel Brushes, Buffs, etc. No. 36 Crawford Street, Newark, N. J.

Regad, E. D.—Lapidary. Specialty—Sardonyx, Black Onyx and Agates. 14 Oliver St., Newark.

PROVIDENCE

Irons, Chas. F.—Manufacturer of Solid Gold Jewelry. Specialty, Emblems, Pins and Charms, Masonic, Odd Fellows, etc. 102 Friendship St.

Lederer, S. & B.—Manufacturers of Fire Gilt, Nickel, Electro and Silver Plated Chains, Necklaces, Charms, etc. Opera, Matinee and Guard Chains. 66 to 72 Stewart St., Providence, R. I.

Pearce & Hoagland—Manufacturers of Gold Pens, Holders, Pencils, Tooth Picks, etc. Also the Quill Reserve Tooth Pick. 29 Point Street, Providence, R. I.

Smith, Wm. T.—Assayer, Refiner and Sweep Smelter. Established 1855. Blackstone and Hawkins Streets, Providence, R. I.

Taylor, Geo. H. & Co.—Watchmakers and Wholesale Dealers in Watches, Clocks, Watch and Clock Material, Tools, Spectacles, Eye Glasses, &c. Particular attention given to trade work. 136 Westminster Street (Room 1), Providence, R. I.

PAWTUCKET.

Draper, J. O. & Co.—Manufacturers of Jewelers' Fig Soap, adapted for Washing Jewelry, Scratch Brushing and Drawing Wire. Pawtucket, R. I.

Fuller, Geo. H. & Son—Jewelers' Findings, Gold, Silver, Gold Plated and Fire Gilt. Pin Stems, Joints, Catches, Split Rings, Chain Hooks and Swivels, Ear Wires, Chain Bars, etc. 99 Exchange Street, Pawtucket, R. I.

Thayer, Ellis & Son—Brush Manufacturers, and Wholesale Dealers in all kinds of Brushes. Sole manufacturers of Ellis Thayer's Patent Polishing Wheels. Manufacturing Jewelers' and Machine Brushes a Specialty. 80 North Main Street, Pawtucket, R. I.

Thayer, P. E. & Co.—Manufacturers of Brushes, Jewelry and Machine Brushes a Specialty. All kinds of Wire Scratch Brushes on hand. Orders by mail or otherwise promptly attended to. 34 East Avenue, Pawtucket, R. I.

CINCINNATI.

Awalt, John A.—Jobber in Watches, Clocks, Jewelry, etc., 173 Vine Street, Cincinnati.

Hellebusch, Clemens—Manufacturer, Importer and Wholesale Dealer in everything required by the Jewelry Trade. 77 W. Fourth St., Cincinnati, O.

Lodwick & Nolting—Wholesale Jewelers, S. W. cor. 4th & Walnut Streets, Cincinnati.

Noterman & Jonas—Manufacturing Jewelers, cor. 4th and Main Streets. Manufacturers of the Ophir Diamond Jewelry.

BALTIMORE.

Gruebel & Kesmodel—Manufacturers of Fine Diamonds, Etruscan, Enameled, Plain and Rhine Stone Jewelry to order. Have an assortment of Diamond Lace Pins, Rings, Ear Rings and Stud Mountings always on hand. The repairing of Fine Enameled and Etruscan Jewelry a specialty. Orders by Mail solicited. Repairing Promptly Done. 212 & 214 W. Baltimore St., Balto., Md.

Morris, Wm. & Co.—Importers and Jobbers of Watch Materials, Tools, Optical Goods, Plated and White Metal Chains. Agents for American Lathes, &c. The attention of Southern Trade is requested. 207 and 209 West Baltimore Street.

BOSTON.

Boyce & Wainwright—Manufacturers of Solid Gold Jewelry. Rings a Specialty. 383 Washington Street, Boston, Mass.

Smith, Wm. A.—Importer of Diamonds and Precious Stones. Diamonds mounted and unmounted and Diamond Mountings. 383 Washington St., Boston, Mass.

BUFFALO.

King & Eisele—Manufacturers of Solid Gold Jewelry, and Agents for American and Foreign Watches; also Jobbers in Roll Plate Jewelry. Office and Salesrooms, 283 Main St. Factory, 2, 4, 6 and 8 Swan St.

CLEVELAND.

Chandler, J. M. & Co.—Manufacturers of the Patent Embossed Bracelet and Jobbers in all kinds of Clocks, Watches, Jewelry, Tools, Materials, etc. 185 Superior St., Cleveland, O.

NORTH ATTLEBORO.

Whiting, F. M. & Co.—Manufacturers of Sterling Silver Ware and Jewelry, North Attleboro, Mass.

LANCASTER.

Bowman & Musser—Jobbers in Watches, Clocks, Chains, Fine Tools and Materials. 20 East Chestnut Street, Lancaster, Pa.

PITTSBURGH.

Goddard, Hill & Co.—Wholesale Dealers in American Watches, Jewelry, Silverware, Clocks, Materials, &c., 43 Fifth Avenue, Pittsburgh, Pa.

SPRINGFIELD.

Bullock, O. W.—Springfield, Mass. Manufacturer of Fine Nickel Plated Watch and Jeweling Tools, Keys, and Light Metallic Goods.

CANADA.

Ellis, P. W. & Co., No. 31 King street, East Toronto, Ontario, Manufacturing Jewelers, Watchmakers, importers and Jobbers of Watchmakers, and Jewelers' Tools, Materials, General Supplies and American Jewelry. Correspondence solicited with manufacturers of Novelties or specialties in American Tools and Jewelry.

POSITIVELY NO GOODS RETAILED.

BOWMAN & MUSSER,

SUCCESSORS TO

E. F. BOWMAN,

JOBBERS IN

Watches, Clocks, Chains,

Fine Tools and Materials,

20 E. CHESTNUT STREET,

Opp. P. R. R. Passenger Depot,

LANCASTER, PA.

Selection Packages sent to Regular Jewelers on Request.

BARNES'

No. 4 LATHE,

For the Heavier Work of Jewelers.

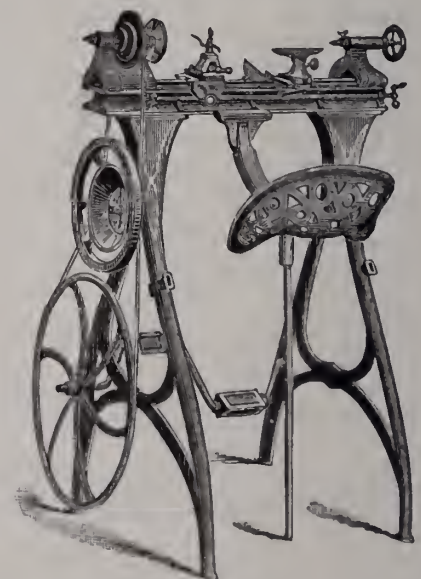

Barnes' Patent Foot and Steam Power Machinery. Complete outfits for Actual Workshop Business. Lathes for wood or metal. Circular Saws, Scroll Saws, Formers, Mortisers, Tenoners, etc., etc. Machines on trial if desired. Descriptive Catalogue and Price List Free.

W. F. & JOHN BARNES,

2088 Main Street, ROCKFORD, ILL.

KOSSUTH MARX & CO.,

— THE —

AMERICAN SILK GUARD M'F'G CO.

MANUFACTURERS OF THE

Largest, Most Complete and Durable
line of

SILK GUARDS

in the market. All styles and lengths.

39 Maiden Lane, New York.

PATENT IMPROVEMENT IN COUNTER + SHOW + CASES,

WITH PERPENDICULAR SLIDING DOORS. DUST PROOF.

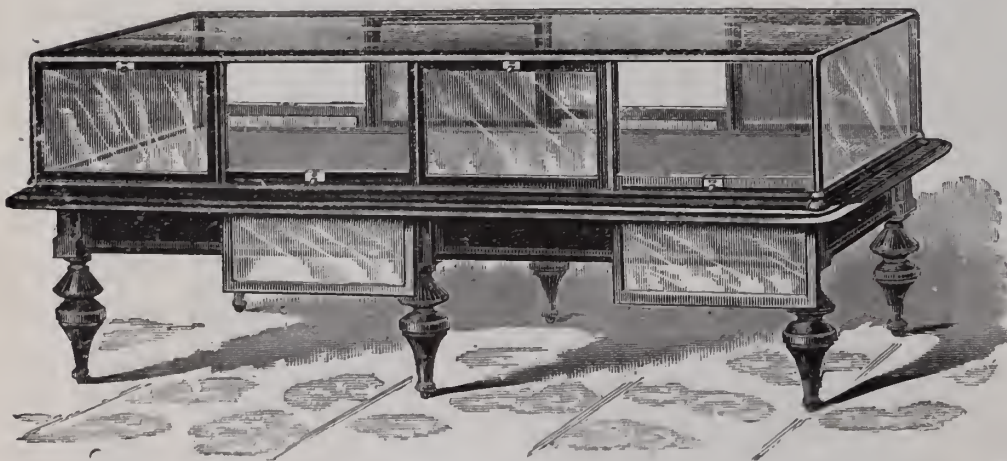

The Advantage and Convenience of these Show Cases will be apparent to everyone.

The doors are more conveniently opened and closed, less liable to get out of repair or broken, articles are more easily reached in wide cases, mirrors are more safe, it dispenses with hinges, economizes room, excludes dust, and is air tight when closed.

Drawings furnished and estimates given for fitting stores in cabinet work complete.

Letters Patent having been granted us for the construction of these doors, we shall prosecute all parties using Cases which infringe on our Patents.

REFERENCES:—Gorham M'g Co., Rogers & Bro., Mitchell Vance & Co.,
Meriden Britannia Co., M. S. Smith & Co., Detroit, Mich.
D. Valentine, Syracuse, N. Y.

B. & W. B. SMITH,
220 West 29th Street, New York.

CATALOGUE OF STYLES SENT ON APPLICATION.

WATERBURY CLOCK CO.,

MANUFACTURERS OF

CLOCKS,

Novelties and Materials,

No. 10 CORTLANDT ST., N. Y.

— AND —

No. 63 WASHINGTON ST., CHICAGO.

Factories, **WATERBURY, CONN.**

M. BAILEY, Treasurer.

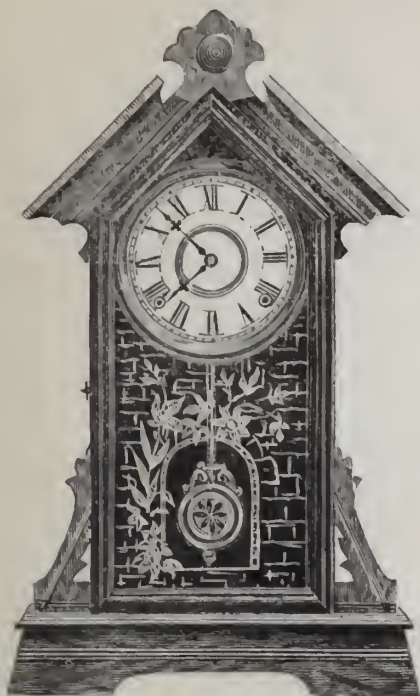

SNOWDEN.



BARNET.

The Ansonia Clock Co.,

Nickel Clocks.

Wood Clocks.

Iron Clocks.

Marbleite Clocks.

Pillar Clocks.

Tower Clocks.

Catalogue and Price List

FOR 1883

Sent on Application.

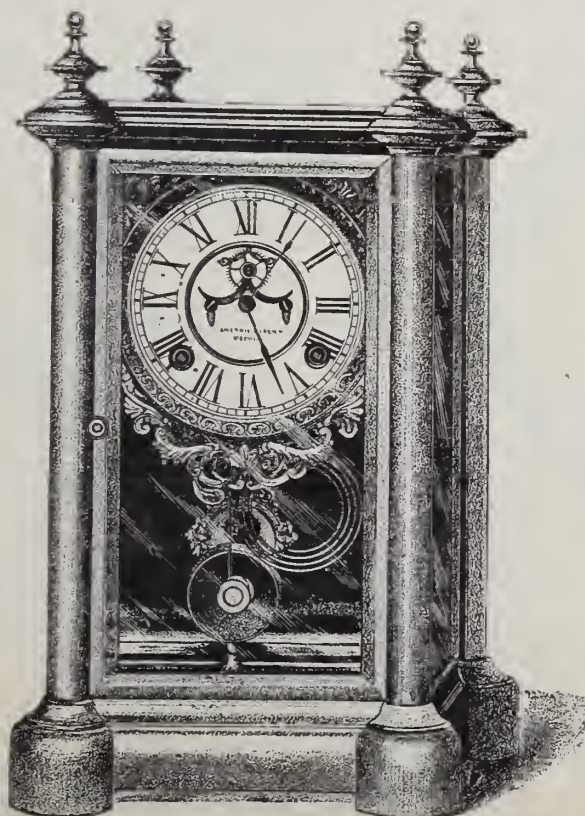

SYMBOL EXTRA.

BRONZES.

CHICAGO,
64 Washington St.

LONDON,
128 Minories.

NEW YORK,
11 to 19 Cliff Street.

W. L. GILBERT CLOCK CO.,

GEORGE B. OWEN, General Manager.



LEBANON.—Walnut.
8 Day Strike.
Height 20½ inches. 6 inch Dial.

Salesrooms:
No. 6 Murray St., N. Y.
54 & 56 Madison St., Chicago.

Factories:
WINSTED,
Conn.

MANUFACTURERS OF

Walnut, Veneered and Other Clocks

IMPORTERS OF

Marble and Cuckoo Clocks.



ENID.—Walnut.
One Day Strike.
Height, 21½ inches. 6 inch Dial.

Catalogue and Price List Furnished upon application.

Grout's Excelsior Louis XIV.

WATCH SIGN,

Manufactured only by the

Excelsior Sign Co.,

CHICAGO.

Finished with the Best

XX GOLD LEAF,

AND

WARRANTED

To Stand in

Any Climate.



Handsome,
Cheap
AND
Durable.

SIZES AND PRICES.

12 Inch.....	\$6 00	24 Inch.....	\$13 50
14 ".....	7 50	26 ".....	18 00
16 ".....	9 50	28 ".....	18 50
18 ".....	10 50	30 ".....	19 50
22 ".....	11 75	36 ".....	27 00

A Full Line of these Signs now on hand and for Sale by

A. I. HALL & SON,

SAN FRANCISCO, CAL.

GROUT'S EXCELSIOR CARVED IRON OCTAGON SPECTACLE SIGN

Carved in the Most Beautiful Manner and Finished with Best XX Gold Leaf.

Everyone



Warranted.

SIZES
And **PRICES**

18 Inches, Glass Panels.....	\$2 50	48 Inches, Glass Panels.....	\$9 00
24 " " ".....	4 00	60 " " ".....	13 00
36 " " ".....	6 75	EXCELSIOR SIGN CO., CHICAGO.	

GROUT'S EXCELSIOR IRON NOSE GLASS SIGN,

Gilded with the

GLASS PANELS.

Best XX Gold Leaf.

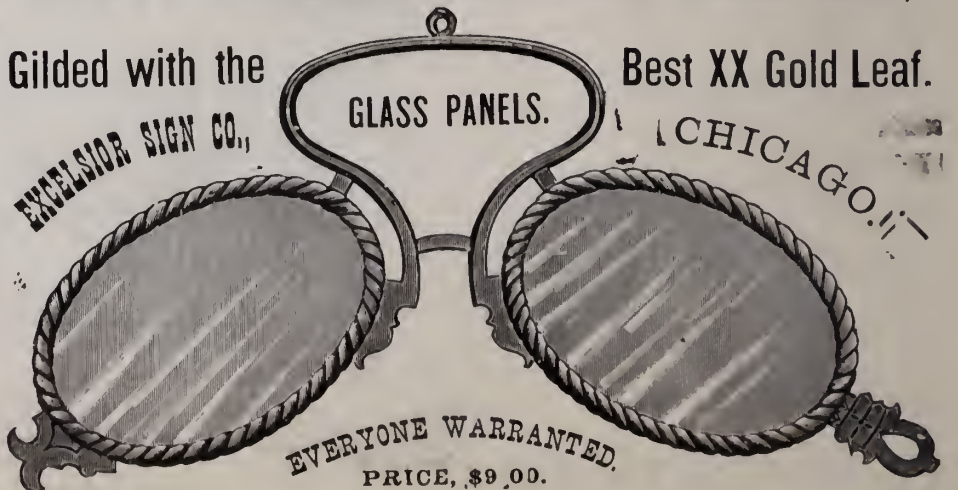

EXCELSIOR SIGN CO.,

CHICAGO!!

EVERYONE WARRANTED.
PRICE, \$9.00.

"THE SARATOGA."—Patented.



—: MADE BY :—

ROGERS & BROTHER,

690 BROADWAY,

NEW YORK.

WORKS, WATERBURY, CONN.

SIMONS, BRO. & CO.

MANUFACTURERS.



CHAIN.



Fine Jewelry.

ILLUSTRATED CATALOGUE



611 and 613 SANSOM STREET, PHILADELPHIA, OR NEAREST JOBBER.

LOUIS STRASBURGER & CO.

DIRECT IMPORTERS OF

WATCHES AND DIAMONDS,

WE MAKE EVERY KIND
OF WATCH IN
OUR OWN
FACTORY.

WE GET THE ROUGH
DIRECT AND CUT
OUR OWN
GOODS.

No. 15 MAIDEN LANE,

NEW YORK.

Rue Leopold Robert,

CHAUX-DE-FONDS.



Boulevard Haussman, 30,

PARIS.

A LARGE ASSORTMENT OF
NEW DESIGNS FOR SPRING OF 1883.

MIDDLETOWN



PLATE CO.

MANUFACTURERS OF

Superior Silver-Plated Ware.

In Tea Sets, Waiters, Berry Dishes, Baskets, Toilet Sets, Jewel Boxes, Presentation Goods, Epergnes, &c., of the Very Best Quality. Also Pitchers, Pitcher Sets, Swing Sets, Etc.

EVERY VARIETY OF HOLLOW AND FLAT WARE.



PATENTED.

Has above CHINA Lining.
Metal Lined \$3.00 LESS.



NO. 54 PITCHER, \$15.75.

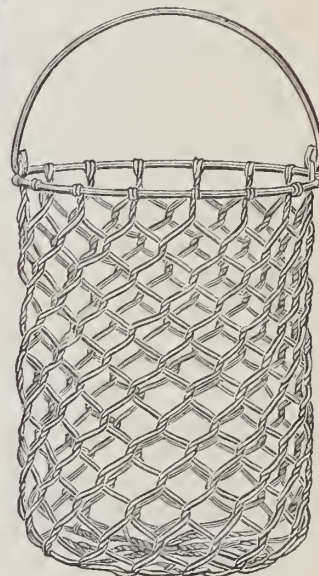

PATENTED.

Bucket to go inside No. 54,
For Ice, \$1.50 extra.

OFFICES.

Middletown, Conn.,
120 Sutter Street, San Francisco, Cal.

13 John Street, New York,
101 & 103 State Street, Chicago, Illinois.

Illustrated Catalogues and Photograph Albums sent to responsible Dealers.

JOSEPH FAHYS & CO.,
 MANUFACTURERS OF
 WATCH CASES,
 38 MAIDEN LANE,

78 Monroe Street, Chicago.

NEW YORK.

Attention is directed to the increased facilities introduced in our Factories for the manufacture of Watch Cases, and the superior class of goods we are now making. It is not too much to say that we are now producing the largest and most complete line of Silver Watch Cases in the country, and that for style, quality, workmanship and finish are not excelled by any other makers.

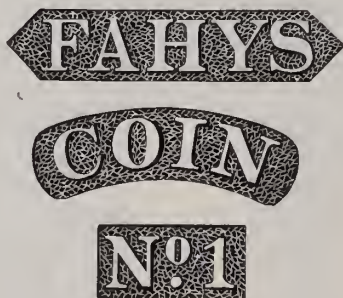

All cases of our manufacture are stamped with a fac-simile of this Trade Mark.

These goods are offered at a much lower price than any other cases sold in this market.

New styles and designs constantly appearing.

A Full Line of Cases always in Stock.

JOSEPH FAHYS & CO.,
 38 MAIDEN LANE, N. Y.

FOR SALE BY ALL THE LEADING JOBBERS IN THE COUNTRY.

—:o T H E o:—

BROOKLYN :: WATCH :: CASE :: CO.'S EAGLE CASE.

The name was first used by this company seven years ago, to designate a case that was full 8-k. in all its parts, no piece, bearing, or joint, being used that was not full 8-k., or that would not stand the test of pure Nitric Acid without showing green. The Backs and Cap are absolutely free from solder, excepting what holds the joints. This Case has gradually won its way in the Trade, until its Standard of Quality is admitted to be just as reliable as that of gold dollars. To those who are disposed to investigate, it can be shown that no gold of less standard than 12-k. can compare at all favorably with the wearing properties of the

→* "B. W. C. CO.'S EAGLE CASE," *←

and cases can be shown that have been in use since 1875, which compare favorably with 14-k.; it is the Best Case ever offered the Trade for the money. All of these goods are stamped in the Cap with the trade mark (B. W. C. Co.) of the Company.

Any 8-k. red or yellow gold, except our Eagle quality, will not stand the acid test, and when kept in safe or show case will soon discolor, and when carried in the pocket will turn black.

This Company always has in stock the largest assortment in 18-k., 14-k., and Eagle Cases, of the latest designs and most desirable styles.

FOR SALE BY ALL THE PRINCIPAL JOBBERS.

DAVID F. CONOVER & CO.

(SUCCESSORS TO WM. B. WARNE & Co.)

Manufacturers and Wholesale Dealers in

WATCHES and JEWELRY.

Wholesale Agents For

Rogers & Brother's Flat and Hollow Ware



Celluloid Eye-Glasses.

And Sole Agents for the

Patent Railroad Train Watch Chains, Nickel.

WHOLESALE AGENTS FOR

T. A. WILLSON & CO.'S Optical Goods.

Would invite attention to the following new grades of Steel Spectacles lately introduced in the market.

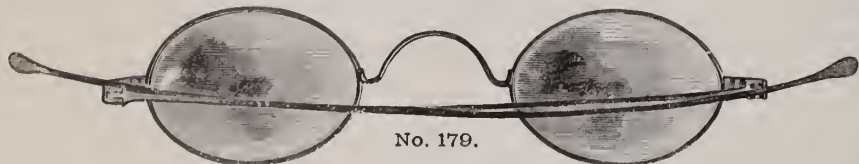

No. 179.

They are Steel, Full Tempered. Parts Interchangeable. Joints so constructed that wear is compensated for. Temple will not work loose and fall down as in old style joints. Nose-piece on No. 155 reinforced where it joins eye, giving extra strength with neatness.

PRIZE MEDALS AT ALL EXHIBITIONS WHERE EXHIBITED.

Patented July 31, 1877.

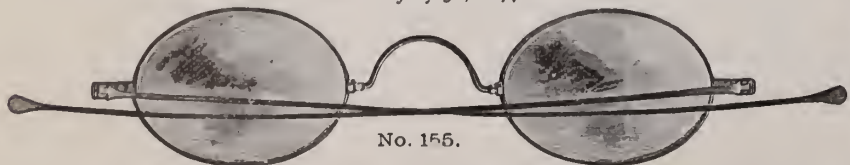

No. 155.

A SPECTACLE TEMPLE THAT WILL NOT WEAR LOOSE.

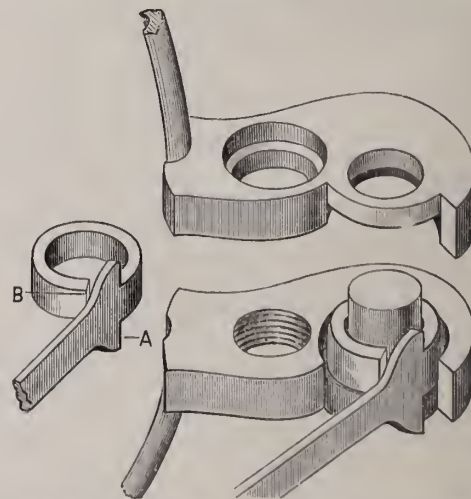

Patented May 13th, 1879. Re-issued June 8th, 1880.

- A.—Stop for Temple, preventing Strain on Joint.
- B.—Compensating eye, for taking up wear of joint. The eye of Temple is smaller than Stubb Steel Joint Pin on which it works, and is left open at B, exerting a Spring Tension on Pin.

American Watch Wholesale Salesroom:
Southeast Cor. Chestnut and Seventh Sts., First Floor,

PHILADELPHIA.

DAVID F. CONOVER,
C. FRANK WILLIAMS
B. EDGAR RIGHTER.

OPPENHEIMER BROS. & VEITH, WATCHES, DIAMONDS, JEWELRY.



We are the Manufacturers and Patentees of the Combination Slide, Pendant and Loeket, and the Combination Necklace, Lace Pin and Pendant.



We can furnish quite a variety of Styles, and are prepared to fill all Orders at once.

35 MAIDEN LANE, NEW YORK.

THE BEST THE DUEBER



WATCH CASE

A WATCH CASE

As Good and as Perfect as



Must be made in the same identical way we make them.

Office of JOHN H. GINGRICH,

DEALER IN

WATCHES, CLOCKS, JEWELRY AND PLATED WARE,

Moberly, Mo., March 16, 1883.

The Dueber Watch Case Manuf'g Co.,

Gents:

At the time of the terrible bridge disaster at St. Charles, Mo., Dec., 1881, Mr. Jack Kirksby went down with his engine and his body was not recovered until the eighth day after. On his person was found his watch, an Elgin Movement cased in a *5 ounce Dueber Bascine Case*. The watch was brought to me after the inquest, and *not a drop of water had penetrated the case*, as the movement was in perfect order. Having sold your cases and no others for many years, believing them to be the best case in the world, I wish to add my testimony to their merits as above.

Yours Respectfully,

JOHN H. GINGRICH.

The Dueber Watch Case Manufacturing Co.,

NEW YORK.

CINCINNATI.

CHICAGO.



1380

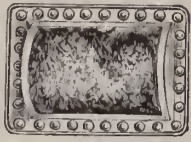

1162



1687



93



1476



0027



864

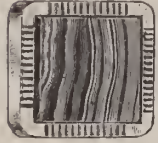

1206



1479



0041



1234



0024



1420



1369

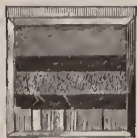

1239

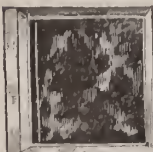

1321



1235



1340



017



93

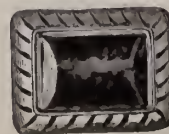

02

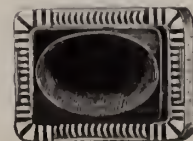

1182



634

THE

ACME LEVER BUTTON



OPEN.



CLOSED.



OPEN.



OPEN.



CLOSED.



CLOSED.



1257

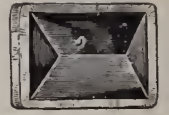

1582



0025

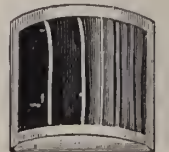

1003



020C



869



1437



1269



1502

THE PERFECT.



105

ROSS PAT.

Spring Season, 1883.

200 NEW DESIGNS OF ENGRAVING.

SPECIAL FEATURES.

SOLID GOLD
BOW,
CROWN,
JOINTS,
PLUGS,
THUMB CATCHES.

HAS REMOVED

from

No. 1 JOHN ST., to

No. 18 JOHN ST.,

NEW YORK.

LERROY W. FAIRCHILD.

MANUFACTURER OF

Gold Pens,

Pen and Pencil Cases, Tooth

Picks, Charms, Whistles, &c., in

Solid Gold, Gold and Platinum, Sterling

Silver, Fine Rolled Gold Plate, Etc., Etc.

CHARLES GLATZ,

MANUFACTURER OF

GOLD & SILVER WATCH CASES

Formerly 10 MAIDEN LANE,

NOW,

N. W. Cor. Nassau & Liberty Sts.

Half Block from Maiden Lane.



BRANCH OFFICE:

100-104 STATE ST.,

Jewelers' Exchange,

CHICAGO, ILL.

S. GOLDSMITH, Manager.

A SPECIALTY OF FULL WARRANTED 8 KARAT GOLD CASES,

Made in a Larger Variety than any other house, and Workmanship fully equal to the best in the Market.

JOBBER IN ALL AMERICAN MOVEMENTS.

We Call the Attention of the Trade to the Line of LOUIS XIV. Cases, in Gold and Silver, which we have Constantly on Hand.

N. W. COR. NASSAU and LIBERTY STREETS, Bryant Building, N. Y. CITY.

EXCLUSIVELY FOR THE JOBBING TRADE.

SIMPSON, HALL, MILLER & CO.,

WALLINGFORD, CONN.

MANUFACTURERS OF

ARTISTIC & USEFUL HOLLOW WARE,

→* ELECTRO PLATED UPON FINE HARD WHITE METAL. *←



Spoons, Forks, etc., plated upon the Finest Nickel Silver in **Extra Double, Triple, and Sectional Plates.** Full lines of over **Forty Staple and Fancy Pieces** in each Pattern in Geneva, St. James, Countess, Windsor, Oval Thread, etc. Made under the supervision, and quality guaranteed and controlled by Wm. Rogers, formerly of Hartford and Meriden. (Wm. Rogers, Sr., died 1873).

WM. ROGERS, Wallingford, Conn.

No connection with any concern in Waterbury, Meriden or Hartford using name of Rogers in any form.

Store and Stock of Goods for Delivery in N. Y. and Vicinity,

No. 36 East Fourteenth Street, Union Square.

Philadelphia, 506 Commerce St.—San Francisco, Cal., 530 Market St.

Montreal, Canada.—Baltimore, 6 German St.

JOBBER IN CINCINNATI, CHICAGO, ST. LOUIS, Etc.

BROWN & BROTHERS,

Finest Silver Plated Flat Ware,

SPRING TEMPERED SHANK. NEW AND CHOICE PATTERNS.

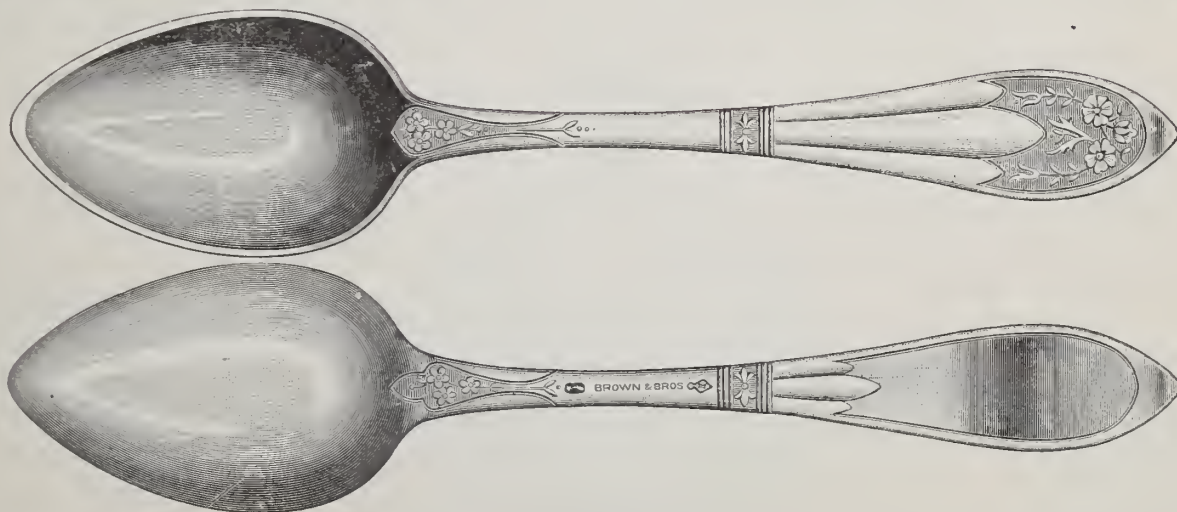

"FLORAL."

We guarantee all our goods to be made of full quality 18 per cent. Nickel Silver, and weight of plate to be as indicated on the labels.

GOODS PACKED ONE DOZEN IN EACH BOX.

Factories, Waterbury, Conn.

Salesroom, 80 & 82 Chambers Street, N. Y.

THE DERBY SILVER COMPANY,

Birmingham, Conn.,

MAKERS OF THE
BEST QUADRUPLE

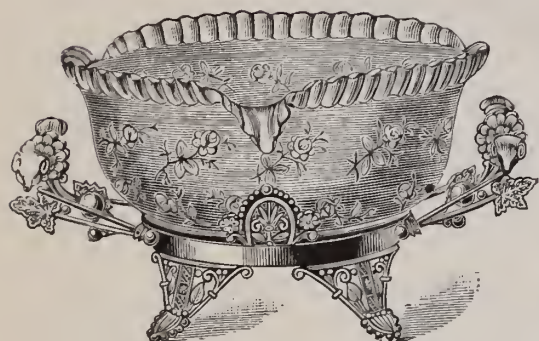

Illustrated Catalogues sent to dealers upon application.

TENTH AND CHESTNUT STREETS, PHILADELPHIA.

MORGAN & HEADLY,

MANUFACTURERS OF

GOLD, SILVER AND STEEL

EYE-GLASSES & SPECTACLES.

OUR TRADE GROWS APACE.

We are constantly improving our Patterns and Machinery, and Educating our Employees, thereby advancing the standard of our business.

The coming season will prove us to be still going ahead in our Special Line. With more extensive Stock and Facilities, and everything advanced except Prices, which are uniformly low, we invite a continuance of your patronage.

IMPORTERS OF DIAMONDS.

Keeping a full assortment, including matched pairs of fine quality, which we will send to the trade on memorandum, at low prices, on receipt of satisfactory reference.

MORGAN & HEADLY, Tenth and Chestnut Streets, Philadelphia.

OFFICE OF
ADOLPH GOLDSMITH,
Importer of Watches,

5 RUE LEOPOLD ROBERT,
Chaux de Fonds.

38 MAIDEN LANE,
New York.

ANNOUNCEMENT.

New York, May 1st, 1883.

Owing to overproduction and in consequence of dull trade, several large consignments of

Swiss Watches and Movements to fit American Cases,

*have been received by me to be sold at **SPECIAL** low figures before **JUNE 1st**. It will be worth your while to call and inspect, or write for samples.*

Respectfully yours,

ADOLPH GOLDSMITH,
38 MAIDEN LANE.

ADOLPH GOLDSMITH,

SOLE AGENT FOR THE

RELIANCE WATCH COMPANY,

38 MAIDEN LANE,

NEW YORK.

FULL LINE OF

Gold and Plated Jewelry.

EVERY DESCRIPTION OF

SWISS WATCHES

A SPECIALTY.

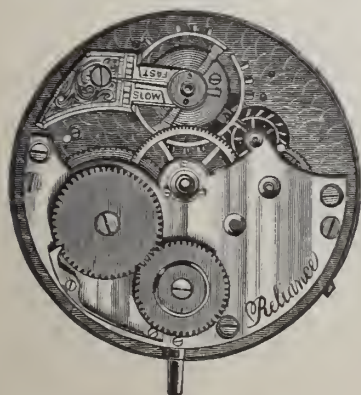

"RELIANCE,"
18 Size, to Fit Waltham Cases.



"RELIANCE,"
Nickel Stem Winder in all Sizes.



"RELIANCE,"
Ladies' 8 Size, to Fit Waltham Cases.

ESTABLISHED 1847.

J. T. SCOTT & CO.,
7 MAIDEN LANE, N. Y.

Importers of Watches and Wholesale Dealers in all grades of American Movements and Cases, **JEWELRY, CHAINS, DIAMONDS, &c.**, and also Importers of the Celebrated

TRIUMPH-ROSKOPF WATCH,



WITH INTERCHANGEABLE
AND ADJUSTABLE
ESCAPEMENT.

Cased in Superior Nickel, Open
Faces, Stem Wind and Set.

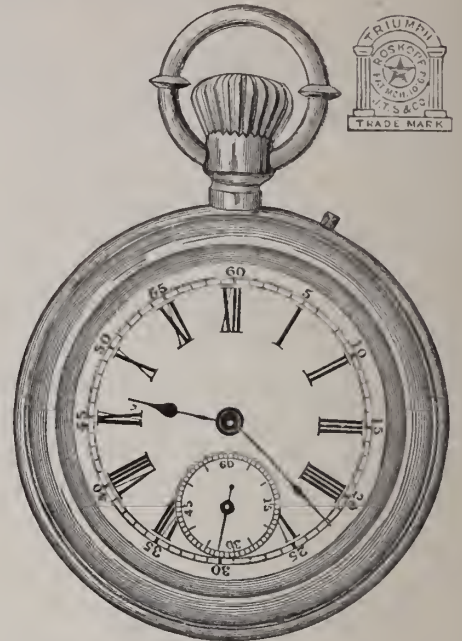

ALSO THE OLD RELIABLE
ROSKOPF WATCH.



All Orders Committed to our Care will receive Prompt and Careful Attention.

MATHEY BROS. & MATHEZ,
NO. 16 MAIDEN LANE.

IMPORTERS OF ALL GRADES OF

Plain and Complicated Watches and Movements

SOLE AGENTS FOR THE WELL-KNOWN

H. L. MATILE

Fine Watches of Astronomical Precision.



REPEATERS.



CHRONOGRAPHS.

In order to facilitate the handling of our Stem-Winding Movements, we have adopted a standard of sizes to fit American Cases. Of these we have a complete line from the medium grade to the highest class goods of fine adjustment and precision. As all our Movements, complicated and plain, are perfectly uniform in quality according to their respective grades, we can furnish material for any parts that may be required, with the positive assurance of accurate interchangeability.

An Extensive Line of all Grades of

CHRONOGRAPHS,
SPLIT SECONDS AND REPEATERS.

WATCHES DEMAGNETIZED.



Manufactory, 47, 49 & 51 Franklin Street, Newark, N. J.

MILLER BROS., JEWELERS,

7 MAIDEN LANE, NEW YORK.

	<p>SETS, EAR RINGS, CROSSES, LOCKETS, LACE PINS, MEDALLIONS,</p>	
MOUNTED WITH		
	<p>STUDS, SCARF PINS, COLLAR BUTTONS, SCARF RINGS, SLEEVE BUTTONS, Etc., Etc., Etc.</p>	

Diamonds, Rubies, Sapphires, Pearls, Turquoise, Birds, Animal Heads and Fancy Ornamentations.

INITIAL GOODS A SPECIALTY.

All goods exclusively of our own manufacture, many of which are protected by MECHANICAL and DESIGN PATENTS.

CROSS & BEQUELIN,

21 MAIDEN LANE, N. Y.

P. O. BOX No. 531.

MANUFACTURERS OF THE CENTENNIAL

CHRONOGRAPH

THE BEST AND CHEAPEST HORSE TIMER

AND THE

Most Accurate Time Keeper in the World for the Money.

IN GOLD AND SILVER CASES.

CHEAP AND RELIABLE.

See Cut. THE EXACT SIZE.



WHOLESALE DEALERS IN ALL GRADES OF

AMERICAN AND SWISS WATCHES, JEWELRY, MATERIALS, ETC.

SOLE AGENTS IN NEW YORK FOR THE SALE OF THE ENGLE ENGRAVING MACHINE.

WM. SMITH & CO.,

MANUFACTURERS OF

GOLD and SILVER Chains & Jewelry,

Also a Large Line of SILVER RINGS.

OFFICE :

No. 25 Maiden Lane, New York.

MANUFACTORY—No 61 PECK STREET, PROVIDENCE, R. I.

W. & S. BLACKINTON,

MANUFACTURERS OF

ONLY

FINE ROLLED PLATE CHAINS,

Necklaces, Polished and Roman, of Latest Gold Designs. Also a Complete Line of Gents' and Ladies' Locketts and Pendants.

In consequence of the first-class reputation our goods have obtained, unscrupulous dealers have been selling goods of an inferior quality, represented as our manufacture. In order to protect ourselves, as well as dealers, all goods of our manufacture will hereafter bear this

TRADE MARK. **W&S.B**★ TRADE MARK.

These Goods are for sale by all Wholesale Dealers.

ESTABLISHED 1873.

CHAS. P. HEROLD,

916 CHESTNUT STREET,

PHILADELPHIA,

(SECOND FLOOR).

Manufacturer of

DIAMOND JEWELRY.
18 K.
DIAMOND MOUNTINGS
A SPECIALTY.
And Exclusively of my own Designs.

ESTABLISHED 1833.

FOR THE SPRING TRADE.

E. IRA RICHARDS & CO.,

MANUFACTURERS (Exclusively) OF

FINE ROLLED PLATED JEWELRY.

The Largest and Choicest Stock in the Country.

SPECIALTY FOR THE COMING SPRING,
BAND & BANGLE BRACELETS & Extra Quality ROLLED PLATED CHAINS.

These Vest Chains are produced to meet the demand for a

ROLLED PLATED CHAIN

that will wear for years. Each Chain bears the initial letters of our firm.

No. 200 BROADWAY, NEW YORK.

2d STORY, FRONT.

GOODS SENT ON SELECTION TO RESPONSIBLE PARTIES.

CHESTER MANCHESTER & CO.,

MANUFACTURERS OF

Gold & Silver Chains,

No. 13 HANOVER STREET,

PROVIDENCE, R. I.

Waltham, Elgin, Illinois,
Hampden, E. Howard & Co.
and Special Movements.

392 WASHINGTON ST.,

BOSTON.

P. O. Box 5259.

D. C. PERCIVAL & CO.,
WHOLESALE DEALERS.

Watches, Jewelry,
Gold Chains, Gold,
Filled and Silver Cases,
Spectacles, Eye - Glasses,
Gold Head Canes, and Rogers &
Bro.'s Flat Ware.

Price List of Movements and Cases

Sent on Receipt of Business Card.

ESTABLISHED 1837.

VICTOR BISHOP & CO.

IMPORTERS OF

DIAMONDS,

**Rubies, Sapphires,
Emeralds & Pearls.**

**Enamel Paintings, Roman Pearls,
Copper, Platinum and Iridium.**

33 MAIDEN LANE, NEW YORK.

House in Paris, 66 Boulevard de Sebastopol.

LOUIS A. SCHERR & CO.

Importers and Wholesale Dealers in

Watches, Jewelry,

WATCH MATERIALS, TOOLS, GLASSES, &c.

Spectacles, Silk Guards, &c.

Wholesale Agents for American Watches.

**No. 726 CHESTNUT STREET
PHILADELPHIA.**

AGENTS FOR THE WHITCOMB LATHE
AGENTS FOR W. F. NYE'S WATCH AND CLOCK OILS.

TO THE TRADE.

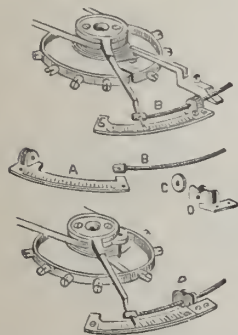

Your attention is called to the Improved Awalt Patent Watch Regulator, Style B. It is made of Nickel, Index and all combined, with Nut C and Screw B made of Fine Steel, to fit all full plate watches, by removing the Index and using the same screw holes and screws on the watch.

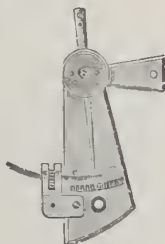

Style D Regulators have been improved in shape and finish, and fit both full plate and bridge watches, are made in Gilt and Nickel, with Nut C and Screw B of Fine Steel. Try them, and it will surprise you to find how much they will aid in making a watch realize you a nice profit.

JOHN A. AWALT, Manufacturer,

ALSO JOBBER IN

WATCHES, CLOCKS, JEWELRY, Etc.,

177 Vine Street,

CINCINNATI, OHIO.

USE GOLD STOCK PLATED CHAINS

With Swivels Stamped

"R. F. S. & CO."

Every Chain Guaranteed by the Makers.

R. F. SIMMONS & CO.

ATTLEBORO FALLS, MASS.

Sold ONLY through Wholesale Houses.

JOHN W. STEELE,

MANUFACTURER OF

FINE GOLD JEWELRY,

—AND—

BRAINERD'S

PATENT

LOCKETS

Patented June 17, 1874.

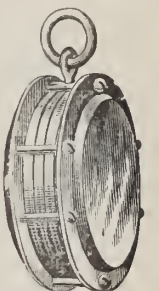

No. 9 Maiden Lane, NEW YORK.

**MATERIALS
AND
OPTICAL GOODS.**

Agents for the

LANCASTER, PA., WATCHES.

A. FRIEDENTHAL & CO.

Manufacturing Jewelers,

AND IMPORTERS OF

WATCHES,

43 MAIDEN LANE, NEW YORK.

COLBY & JOHNSON,

Manufacturers and Jobbers,
17 MAIDEN LANE, NEW YORK.

WATCH CASES,
FINE JEWELRY,
AMERICAN WATCHES.

SOLE MANUFACTURERS OF

CELLULOID WATCH CASES,

MOUNTED IN
GOLD, SILVER OR NICKEL.

DAY & CLARK,

MAKERS OF

FINE ROMAN GOODS,

BANGLES,

Plain and Ornamented Bead Necklaces.

Every style & size of Diamond Ear Ring Covers,

LACE PINS AND EAR DROPS.

STONE SEALS AND LOCKETS.

192 Broadway, cor. John Street,

FACTORY, NEWARK, N. J.

NEW YORK.

ESTABLISHED 1833.

WELCH & MILLER,

JEWELRY
Case Manufacturers,

Of Morocco, Velvet, Russia, Brocade and Plush.

SHOW CASE TRAYS OF ALL DESCRIPTIONS.

LOCK RING TRAYS FOR DIAMOND RINGS.

Agénts for Jewelers' Cotton and Twine.

All Goods of our Own Manufacture, and a Large Stock
Always on Hand.

169 BROADWAY, NEW YORK.

SUSSFELD, LORSCH & NORDLINGER,

IMPORTERS OF

Optical & Mathematical Instruments,

Watchmakers' Tools, Materials, Etc.

SPECIALTIES:

BARDOU & SONS' Universal Opera Glasses U. S. Army and Navy Glasses.
Rifle Range Telescopes, Etc., Etc.

LA REINE Opera and Marine Glasses.

CROWN Spectacles and Eye-Glasses.

PARADIS MAINSPRINGS.

PARAGON TOOLS.

13 MAIDEN LANE, NEW YORK.

16 Rue D'Enghien, PARIS.

JAMES W. TODD,

SUCCESSOR TO GEO. W. PLATT,

→* Wholesale Dealer in *←

WATCHES & JEWELRY,

GOLD AND SILVER SPECTACLES

And Eye-Glasses,

No. 6 LIBERTY PLACE,

NEW YORK.

DORRANCE, EDGE & CO.,

Sole Manufacturers of the Celebrated

Woven Fabric Gold Chain,

Elegantly Mounted Bracelets, OPERA, LEONTINE.

VICTORIA WATCH GUARDS AND NECKLACES

In all the Newest Designs.

Our Stock is unusually complete, and in addition to the above a
variety of NECKLACES, from 1½ to 40 dwts. each, to
which we invite the attention of buyers.

CHILDREN'S BRACELETS A SPECIALTY.

No. 15 JOHN ST., NEW YORK.

FACTORY, 46 GREENE ST., NEWARK, N. J.

HELLER & BARDEL

MANUFACTURERS OF



JEWELRY,

13 John St., New York.

A Full Line of DIAMONDS, Mounted and Unmounted, Always on hand, which we will send for Selection to Responsible Houses.

All Goods Ordered on Selection or for Stock are Insured while in the Hands of the Express Companies.

R. WALLACE & SONS M'FG Co.,

MANUFACTURERS OF



SILVERWARE,

GUARANTEED $\frac{925}{1000}$ FINE.

WALLINGFORD, CONN.

H. P. HILDRETH,

MANUFACTURER OF

SOLID GOLD RINGS,

PLAIN AND ORNAMENTAL,

10 JOHN STREET, NEW YORK.

Factory, 1305 ATLANTIC AVENUE, Brooklyn.

Best Quality of Goods at Lowest Cash Prices.

Send for Price List, as I have no Agents.

COX & SEDGWICK,

26 JOHN STREET, N. Y.,

Makers of Patent Black Onyx Bracelets

Also Black Onyx Faceted Bead Bracelets,
AT THE LOWEST PRICES.

COLORED

AND

Turquoise

Lace Pins,
Ear Rings,
Locketts,
Bracelets,
Sleeve

Buttons,

Scarf Pins,

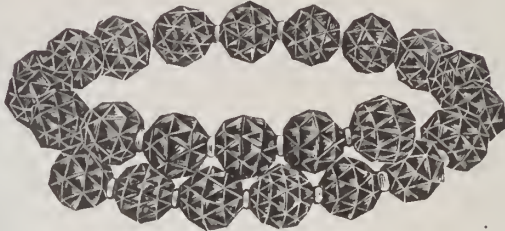

ONYX

Lace Pins,
Ear Rings,
Medallions,
Necklaces,
Chatelaines
Sleeve Buttons
Ladies & Gents
Vest and
Guard Chain.

Black Onyx Pins, Ear Rings and Locketts for 1, 3 and 5 Diamonds.

GOODS SENT ON APPROVAL TO RESPONSIBLE FIRMS.

WOOD & HUGHES,

STERLING

SILVERWARE MANUFACTURERS,

New York Agents for the Derby Silver Co.'s

Fine Quadruple Plated Ware,

No. 16 John Street, N. Y.

206 Kearney Street, San Francisco, Cal.

HASKELL & MUEGGE, Agents.

J. B. & S. M. KNOWLES,

MANUFACTURERS OF

Sterling Silver Ware,

No. 20 MAIDEN LANE,

NEW YORK.

FACTORY, PROVIDENCE, R. I.



Gorham M'f'g Co.,

SILVERSMITHS.

→*NEW YORK,*←
 37 Union Square.

→*CHICAGO,*←
 170 State Street.

→*SAN FRANCISCO,*←
 120 Sutter Street.

ALFRED H. SMITH & CO.
IMPORTERS OF

DIAMONDS



182 BROADWAY
COR OF JOHN ST.

NEW YORK

No 125 STATE STREET · 33 HOLBORN VIADUCT.

·CHICAGO·

·LONDON·

S. J. COX SC. DEL. N. Y.

T H E

NEW HAVEN CLOCK CO.

MANUFACTURERS,
IMPORTERS,
DEALERS.

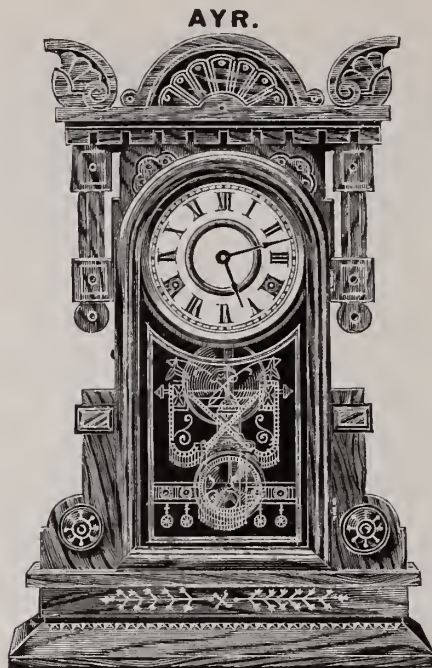

FACTORIES.
NEW HAVEN, CONN.

GENERAL OFFICE AND SALESROOMS.
62 READE STREET,
New York.

WESTERN OFFICE AND SALESROOMS.
31 WASHINGTON ST.,
Chicago, Ill.

EUROPEAN OFFICE AND SALESROOMS.
16 PITT STREET,
Cleveland Sq., Liverpool,
England.

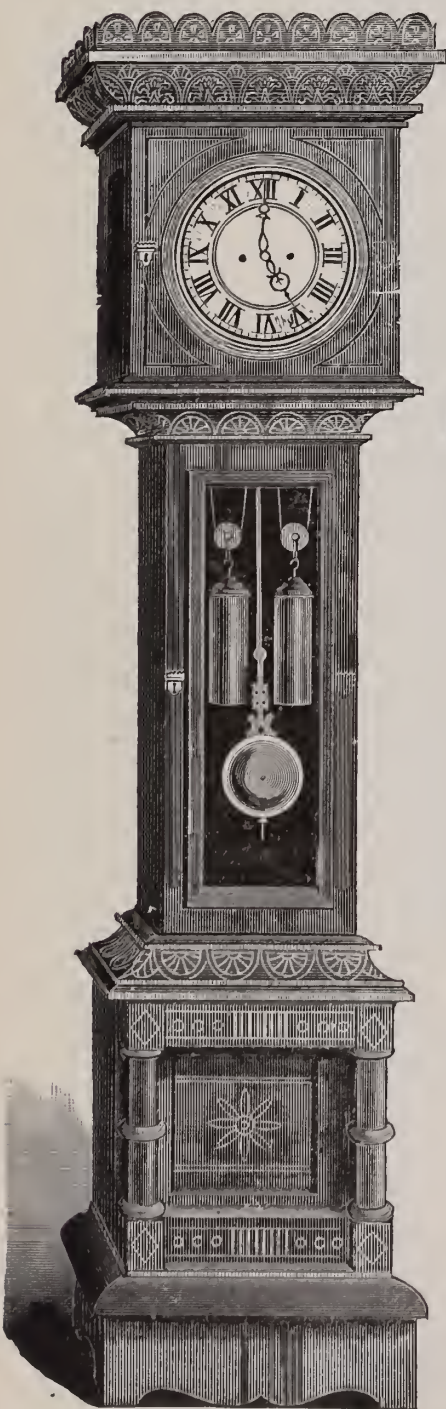

CARVED WOOD,
 English Regulator.

WE have again introduced many Popular Improvements as well as New Designs, combining the most desirable effects and thorough construction with moderate prices. Among these will be found our new 8-day Pendulum Movements, striking hours and half hours on Gong Bells with Cathedral tones. By this means we bring within the reach of all the best selling points of the most expensive imported clocks.

We also call attention to the fact that we sell these Cathedral Gongs either separately or fitted in any of our Visible Pendulum Clocks at a moderate extra charge.

We now have the greatest facilities for

IMPORTING

all kinds of

French Clocks

and

BRONZES,

and are pleased to ask our patrons to give this fact their careful attention and allow us, by a trial, to show them that we can offer a better and cheaper assortment than any other house.

Send for Complete Catalogue of All Styles.



MARBLE,
 Imported.

Carter, Sloan & Co.

HAVE REMOVED TO

No. 15 Maiden Lane,

New York.

May 1st, 1883.



CARTER, SLOAN & CO.,
MANUFACTURERS OF ALL KINDS OF

GOLD JEWELRY,

No. 15 MAIDEN LANE,
NEW YORK.

A. CARTER, JR.
A. K. SLOAN,

C. E. HASTINGS,
G. R. HOWE.

BALDWIN, SEXTON & PETERSON,

IMPORTERS OF

DIAMONDS and all PRECIOUS STONES,

MANUFACTURERS OF

DIAMOND AND RICH JEWELRY.

Cutters and Polishers of

DIAMONDS

692 & 694 BROADWAY, NEW YORK.

120 SUTTER ST., SAN FRANCISCO, CAL.

J. F. Chatellier,
Manufacturing Jeweler,

692 & 694 Broadway,

New York.



TRADE

MARK.

STERLING.

Whiting Manufacturing Co.

SILVERSMITHS,

BROADWAY & FOURTH ST., N. Y.

ESTABLISHED 1837.

TAYLOR & BROTHER,

Old House READ, TAYLOR & CO.,

Importers of Diamonds and Pearls,

—)AND(—

MANUFACTURERS OF DIAMOND JEWELRY,

21 Holborn Viaduct, 676 Broadway,

LONDON.

NEW YORK.

ESTABLISHED 1813.

THOMAS G. BROWN & SONS,
Newark, N. J., & 5 Bond Street, New York.

MANUFACTURERS OF

ARTISTIC JEWELRY
FOR PRESENTATION,

Including Prizes for ROWING, RIFLE SHOOTING, ARCHERY and
all ATHLETIC SPORTS.

COLLEGE SOCIETY PINS AND CLASS RINGS, ALSO BADGES FOR MILITARY
AND CIVIC BODIES IN ALL METALS.

Employing able Designers, and having all work, both in Designing and Manu-
facturing, done in our own factory, we can submit, for the inspection of those
interested, entirely original designs, appropriate in style, and not to be seen else-
where.

Estimates and Designs will be sent to Reputable Dealers when desired.

ESTABLISHED 1834.

G. & S. OWEN & CO.,

—MAKERS OF—

FINE ROMAN JEWELRY, &c.

—&c. BOX and GLASS PINS,

—AND—

Black Onyx and Pearl Goods,
OF EVERY DESCRIPTION.

All Goods sold by us are exclusively of our own manufacture and are warranted 14 K. Fine, and stamped as such when possible.

No. 3 Maiden Lane, New York.

W. H. SHEAFER & Co.,

MAKERS OF

BRACELETS,

BANGLES,

LACE PINS,

SCARF PINS, ETC.

No. 15 JOHN STREET,
NEW YORK.

RIPLEY HOWLAND M'FG CO.,

MAKERS OF

FINE JEWELRY,

SPECIALTIES:

DIAMOND MOUNTINGS, with Platinum Tips.
ENGRAVED RINGS, STONE RINGS,
OFFICE, 17 MAIDEN LANE,
NEW YORK.

FACTORY, 383 WASHINGTON ST.,
BOSTON, MASS.

SAXTON, SMITH & CO.,

Manufacturers of

GOLD CHAIN

SOLE AGENTS

FOR THE

NEW PATENTED CHAIN BAR,

Containing a Detachable Pencil.

FACTORY:
183 EDDY ST.,
PROVIDENCE, R. I.

OFFICE:
14 JOHN ST.,
NEW YORK.

A. J. HEDGES & CO.,

MANUFACTURING

JEWELERS,

No. 6 MAIDEN LANE,

NEW YORK.

Factory, No. 90 MECHANIC ST.,
NEWARK, N. J.

A. W. FABER'S

CELEBRATED

Gold Pens & Pencil Cases.
TOOTH PICKS AND NOVELTIES.

Manufactured by

EBERHARD FABER,

Nos. 718 and 720 Broadway,
NEW YORK.

FOWLER BROS.,

MANUFACTURERS OF

JET & ONYX JEWELRY.

Offer a large and varied stock of desirable goods of original designs, especially manufactured for the coming Fall Trade. These goods are elegant in design, beautifully finished, and must be seen to be appreciated.

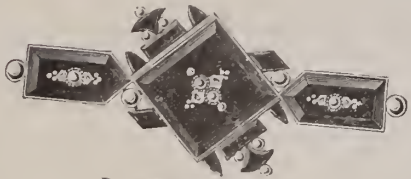

Pat. March 27, 1883.



Pat. March 27, 1883.

Are carried

by all the leading

Jobbing Houses

throughout the country.

MOORE & HORTON,

No. 11 Maiden Lane,

NEW YORK.

JEWELERS,

SPECIALTIES:

Stone Cameo, Onyx, Amethyst, Topaz and Pearl Rings.

Studs, Collar and Sleeve Buttons.

Also our fac-simile of Fine African Diamonds, with Foile Back, Mounted in Rings, Studs, Pins, Ear Rings, Scarf Pins, Lace Pins, &c.

CHAUNCEY IVES.

JOHN F. SAUNDERS,
Of the late firm of Buckenham, Cole & Saunders.

SAUNDERS & IVES,

IMPORTERS OF

DIAMONDS, PEARLS,

And Other Precious Stones.

Manufacturers of Diamond Mountings.

No. 26 MAIDEN LANE, NEW YORK.

A Large Stock of FINE DIAMONDS, Mounted and Unmounted, kept constantly on hand.

Goods sent on approval to any part of the country on receipt of satisfactory reference. All our goods ARE INSURED by us while in transit.

CHAMPENOIS & CO,

NO. 5 MAIDEN LANE, NEW YORK.

Manufacturers of Solid Gold Jewelry,

AND THE

"BEST LEVER"

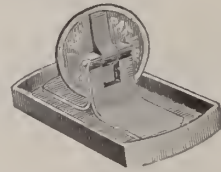

SLEEVE AND COLLAR BUTTON.

Also Sets, Ear Knobs, Bracelets, Studs, Lace and Cuff Pins, Onyx and Jet Cluster Goods.

Specialty:—Engraved and Enameled Goods.

G. W. PRATT & Co.,

Manufacturers and Dealers in

Watches and Jewelry

OF EVERY DESCRIPTION.

ELGIN AND ILLINOIS MOVEMENTS

IN ALL GRADES.

Gold, Silver and Ladd Patent Cases.

No. 14 JOHN STREET, NEW YORK.

C. ROSSWOG & SON,

MANUFACTURERS OF

Rich Jewelry and Diamond Goods,

Nos. 5 & 7 MAIDEN LANE,

NEW YORK.

CHAS. F. TERHUNE & CO.,

Rolled Plate Chains and Gold and Plated Jewelry,

MANUFACTURING JEWELERS.

Terhune's Patent Slide Buttons.



194 Broadway,



NEW YORK.

S. W. HALE & CO.,

SUCCESSORS TO HALE & MULFORD,

MANUFACTURERS OF

FINE JEWELRY

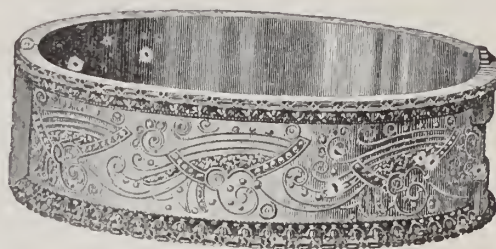

692 BROADWAY, N. Y.

SETH W. HALE.

WILLIAM A. LEE.

WILLIS H. HOWES.

JULIEN GALLET & CO.,
IMPORTERS OF

WATCHES

OF EVERY GRADE,

No. 1 MAIDEN LANE,

NEW YORK.

SPECIAL NOTICE.

Office of JOHN T. MAURAN,

Manufacturing Jeweler,

15 MAIDEN LANE.

NEW YORK, February 1st, 1883.

The business of Manufacturing Jewelry, founded by the late John T. Mauran, will be continued without change by the undersigned, retaining the old office at No. 15 Maiden Lane, New York.

Thanking you for your generous favors of the past, we hope, by keeping the stock up to its old standard of quality and excellence, and by continued addition of New Designs, to merit a continuance of your patronage.

H. C. CRANSTON,

Administrator and Representative of the Heirs.

SMITH & KNAPP,

WHOLESALE DEALERS IN

AMERICAN AND SWISS WATCHES,

DIAMONDS.

Gold & Plated Jewelry & Gold Chain,

No. 182 BROADWAY,

COR. OF JOHN STREET,

NEW YORK.

OFFICE:
14 JOHN STREET, N. Y.

E. STITES' SONS.

FACTORY:
NEWARK, NEW JERSEY.

TRAITEL BROTHERS,

40 Maiden Lane, New York.

MAKERS OF

STANDARD QUALITIES

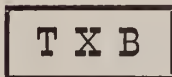

10-k.

TRADE MARKS.



14-k.

SOLID GOLD RINGS.

Ask your Jobber for our Standard Qualities.

REMOVAL.

NOAH MITCHELL,

Manufacturer of

Diamond Jewelry and Mountings,

From 694 BROADWAY

TO

No. 52 MAIDEN LANE,

NEW YORK.

MAY 1ST, 1883.

Webster's Silver Solution,

PREPARED BY

E. G. WEBSTER & BROTHER,

(Established 1859.)

Manufacturers of Quadruple

Electro Silver Plated Ware

14 MAIDEN LANE, N. Y.,

Expressly for Cleaning Silver and Silver Plated Ware.

Jewelers will find this a valuable adjunct for cleaning their stock, and a reliable article to recommend to their customers.

Guaranteed entirely free from Cyanide, Acid, Grit, or anything detrimental to the Finest Wares.

Packed in Boxes containing 2 Doz. Bottles.

Price, \$1.25 per Doz., NET.



PEARCE & HOAGLAND,

MANUFACTURERS OF

Gold Pens, Pencils, Pen Holders, Tooth Picks,

OF EVERY DESCRIPTION.



CLOSED

SOLE MANUFACTURERS OF THE

QUILL RESERVE TOOTH PICK,

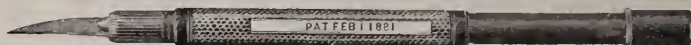

OPEN



CLOSED

The Holder of this Case is made in various styles in Gold Plate, Celluloid, Ivory, etc., while the Pick is of ordinary Goose Quill, and can be easily replaced by a new one, at any time, from the Reserve in the end of the Holder, and is the only Pick that will not injure the Teeth.

FOR SALE BY ALL JOBBERS.

Office and Factory, 29 Point Street, Providence, R. I.

Removal of New York Office.

YALE CLOCK CO.,

NEW HAVEN, CONN.,

MANUFACTURERS OF

NOVELTIES IN CLOCKS.

A. I. HALL & SON, General Agents.

New York Office Removed to 52 Maiden Lane.

528 & 530 Market St., San Francisco, Cal.

Patented November 18, 1873.

MORRISON'S

Gold & Silver Solutions

For Electro-Plating Without a Battery.

Invaluable for Watchmakers and Jewelers. So simple that any one can use them.

Price, Gold Solution, - - \$3.00 Silver Solution, - - \$1.50

MANUFACTURED BY

ARTHUR B. MORRISON, Portland, Maine.

FOR SALE BY

Sussfeld, Lorsch & Co., New York; Henry Ginnel, New York; Cross & Beguelin, New York; Kearney & Swarthild, Chicago, Ill.; Louis A. Scherr & Co., Philadelphia, Pa.; Duhme & Co., Cincinnati, O.; Harwood Bros., A. Paul & Co., Palmer, Bachelder & Co. Boston, Mass., and material dealers generally.

BEWARE OF BASE IMITATIONS put up by unprincipled persons. None are genuine without the Trade Mark which consists of the letters A. B. M. in monogram and fac simile of Medal awarded by U. S. Centennial Commission.

MANUFACTURERS OF Everything in

BLACK ONYX JEWELRY

PLAIN, and {Ornamented with Pearls and Diamonds.

Our manufacturing facilities have been for the past ten years devoted exclusively to the production of fine Black Onyx Jewelry. We carry in stock the largest variety of articles made in our specialty, well made, finely finished, uniformly 14 karats, at medium and low prices.

WOGLOM & MILLER,
Office & Factory, 32 & 34 JOHN STREET,
NEW YORK.



W.M. GREENE & Co.
GOLDSMITHS

MANUFACTURERS of

RICH SETS IN TAPER WIRE CORAL

Factory 95 PINE ST. Providence, R. I.

Stone Cameo
Amethyst
Coral Cameo
Engraved
Enamel Sets
Sleeve Buttons
Stud Buttons
EAR DROPS
&c. New York Office 192 BROADWAY.

WM C GREENE R. W GREENE GEO. D. BRIGGS

KETCHAM & McDOUGALL,
Bryant Building, (55 Liberty St.) New York.

MANUFACTURERS OF
COLD AND SILVER THIMBLES.



THE AUTOMATIC EYE-GLASS HOLDER,
It Reels Up Cord Itself.
A—Shows position of Glasses with cord Reeled up.

ESTABLISHED 1859.

STURDY BROS. & CO.

MANUFACTURERS OF

Fine Rolled Plate Jewelry,

GRADUATED WIRE CORAL GOODS,
STERLING SILVER JEWELRY.

Bangles,
Sleeve Buttons,
Cuff Buttons,
Baby Pins,
Sets in Stone, Cameo, Enamel,
Chased, and Polished,
Drops and Knobs,
Bar Pins,
Children's Sets,
Locketts,
Studs,
Charms,
Etc.

Only Wholesale Dealers' Trade Solicited. ATTLEBORO, MASS.

Flexible Bracelets,
Diamond Mountings,
Strung Pearl Work,
Repairing,

Flexible Braided Bracelets,
White Stone Goods,
Strung Pearl Repa'ng

Thos. M. Guilbert & Co.,

SUCCESSORS TO CARROW, DUBOSQ & Co.

908 Chestnut Street, Philadelphia, Pa.

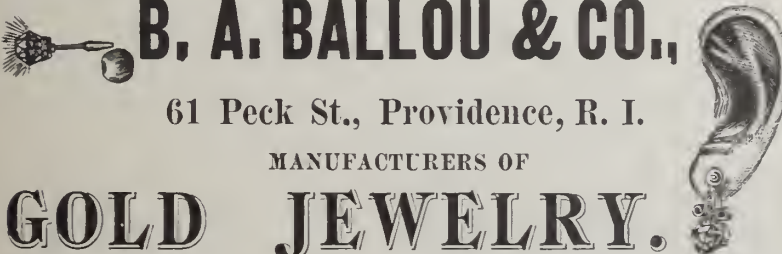

B. A. BALLOU & CO.,

61 Peck St., Providence, R. I.

MANUFACTURERS OF

GOLD JEWELRY.

We call special attention to our PATENT FASTENING FOR EAR RINGS, which is free from the objections raised to ordinary ear wire or screw fastenings. They present a very neat and attractive appearance, are perfectly secure, and much more convenient than ordinary ear wires which always annoy the wearer by catching the hair, veil, or lace about the neck. These Goods are for Sale by all Wholesale Dealers.

Gold Studs, Small Chains for Eye-Glasses, Bracelets, Etc. a Specialty.



This cut represents the exact size and style of the Jewelers' League Badge.

as adopted by the League at the last annual meeting. Badges can be had by sending \$3.00 to JOHN FRICK & CO., 23 MAIDEN LANE, (P. O. Box 2070), NEW YORK.

The circle is blue enamel, and the League number can be added, if required, on a small piece of gold affixed to the bottom of the badge.

ORDERS FOR MEDALS, BADGES, ETC., SOLICITED.

McCarty & Hurlburt,

WHOLESALE DEALERS IN

WALTHAM, ELGIN & ILLINOIS

WATCHES.

MANUFACTURERS OF

Jewelry, Gold Spectacles, Silver Thimbles, &c

131 North Second St.,

PHILADELPHIA, Pa.

CLOCKS

ESTABLISHED 1853.



AMERICAN
AND
FRENCH CLOCKS
AND
BRONZES.

B. J. COOKE'S SONS,
137 N. 3d Street, PHILADELPHIA.
Catalogues and Price Lists furnished to the Trade only, on application.

BOOZ & CO.,

MANUFACTURERS OF
FINE GOLD
Watch Cases
AND
PLAIN GOLD
RINGS.
Jobbers in American Movements.
DIAMONDS.



108 South Eighth St., (2d Story) Philadelphia.
Samples of our goods sent on approval when satisfactory reference is furnished.
Old Gold and Silver Bought or Exchanged.
PARTICULAR ATTENTION PAID TO REPAIRING.



The ORIGINAL GOLD CROWN
FILLED RINGS.

For the past thirteen years we have manufactured as a specialty, the well known "CROWN GOLD FILLED RING," with the high standing of which the trade is already perfectly familiar. In consequence of the above fact, and in justice to ourselves, we feel it a duty to make the announcement to the trade that there are now being offered in the market several other makes of filled rings, each of which has a CROWN in some way connected with its STAMP.

We Manufacture for the Jobbing Trade Only.
McGALL & NEWMAN,
625 Arch Street, Philadelphia

Vol. XIV. ESTABLISHED 1869. Vol. XIV.

THE
JEWELERS' CIRCULAR

AND HOROLOGICAL REVIEW.

The XIV Volume began with the February Issue.

\$2.00 per Annum to all parts of the United States and Canada,
and all Foreign Subscriptions \$3.00.

D. H. HOPKINSON,
42 Nassau Street, NEW YORK.

BLANCARD & OBERLANDER,
MANUFACTURERS OF
Settings and Galleries,
IN THE LATEST STYLE.

BALL WIRE, Solid and Hollow, in 14 and 10 karat, also single Hollow Balls without joint, of all sizes, in Silver and 14 karat alloy and upwards.
Made in any thickness of Gold to order.

Platinum, Platinum-Lined and Fancy Settings a Specialty.
PLATINUM SCRAPS EXCHANGED OR PURCHASED.
36 & 38 JOHN STREET, N. Y.
PLEASE SEND FOR SAMPLE CARD.

Mansfield Watch Tool Co.

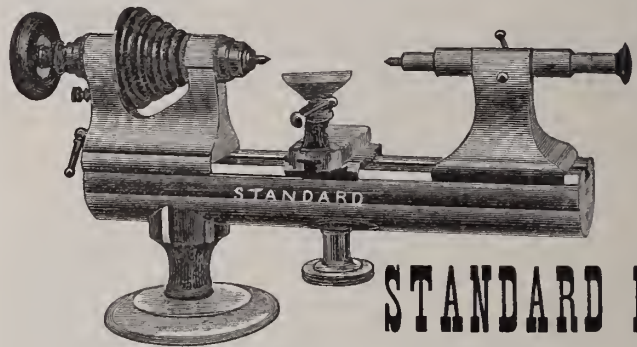

Mansfield
MASS.,
Makers of the

STANDARD LATHE,

Chucks, and Watchmakers' FINE Tools of all kinds.
SEND FOR NEW PRICE LIST.

REMOVAL.
HENRY CARTER,
DIAMONDS, WATCHES, JEWELRY.
TO BRYANT BUILDING,
Cor. Nassau and Liberty Streets, NEW YORK.
CELEBRATED H. C.
★ BRAND ROLLED GOLD CHAINS.

William T. Smith,
ASSAYER, REFINER AND SWEEP SMELTER.



ESTABLISHED IN 1855.

Cor. Blackstone & Hawkins Sts

PROVIDENCE, R. I.

BOSTON, Mar. 15, 1883.

To whom it may Concern:

Mr. Wm. T. Smith, of Providence, R. I., has done refining for us for years, as well as his father before him, and we take pleasure in saying we have never received anything but satisfaction in our dealings with him.

RIPLEY HOWLAND MFG. CO., R. Crosby, Treasurer.

JEWELRY AND WATCHES.

ROGERS' SILVERWARE.

MATERIALS AND TOOLS.

S. F. MYERS & CO.,
Manufacturers and Jobbers,
179 BROADWAY, NEW YORK.

ILLUSTRATED CATALOGUE FOR THE TRADE.

W. E. WHITE & CO.,
Manufacturing Jewelers.



**FINE
ROLLED PLATE
GOODS.**

Bracelets---Engraved, Enamelled, Flat Band and Buckle.

Ladies' Goods—Lace Pins, Drops, Crosses, Sets, Collar Buttons, &c.
FOR SALE BY JOBBERS ONLY.

New York Office, 26 MAIDEN LANE, Corner Nassau Street.

Factory 54 Page St., Providence, R. I.

Represented by S. A. BALDWIN.

ALEX. MILNE,
Manufacturer of Stem-Winding Watch Crowns



ALSO GOLD AND SILVER THIMBLES.



19 Ward Street, NEWARK, N. J.

PFORZHEIMER, KELLER & CO.

MANUFACTURERS OF

FINE JEWELRY,

AND DEALERS IN

Diamonds, American and Swiss Watches,

No. 24 JOHN STREET,

NEW YORK.

I. PFORZHEIMER, }
D. KELLER.

{ I. B. ETTINGER,
{ H. J. FINK.

Henry Ford,

Importer of Rough & Polished Diamonds,

DIAMOND CUTTING AND POLISHING WORKS:

21, 23, 25 Looijersgracht.

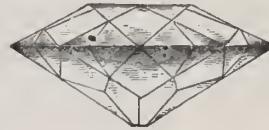

4 & 6 JOHN ST.,

Amsterdam, Holland.

New York.

Diamonds repaired and matched by some of the finest workmen in the world.

Diamond Bort and Powder always on hand.

ESTABLISHED 1850.

TRADE



MARK

PETER L. KRIDER,
MANUFACTURER OF
STERLING SILVERWARE

Medal and Diploma Awarded. &c. Striking Society
Medals in Gold, Silver or Bronze a Specialty.

Artisan Hall, 618 Chestnut St., Philadelphia.



KING JAMES, }
MARQUIS, } RINGS.
GLOVE, }

Quality Guaranteed.
Prices Close.

BARNET BROS. & POWELL,
—Manufacturers,—

Newark, N. J., & 15 JOHN ST., NEW YORK.

R. & K.'S PATENT GAS FURNACES FOR MELTING, PLATING,
ENAMELING, ANNEALING, &c., &c.

Reichhelm & Koester,

Importers and Manufacturers of

Jewelers' Tools, Files, Materials, &c.,

Manufacturers of
Bristle Brushes of all kinds,
Cotton and Wool Buffs,
Felt Polishing Wheels,
Walrus Lea her Polishing
Wheels,
Jewelers' Satin Finish and
Scratch Brushes,
Brass & Steel Wire Brushes
Jewelers' Standard Saw
Frames,
Plain & Fancy Draw Plates,
Improved Jewelers' Ingots,
R. & K.'s Jewelers' Combina-
tion Gas Burners.

80 Nassau St.

NEW YORK.

Importers of
French, English & German
Tools and Files,
Piercing Saws,
Remard & Vautier Gravers,
Steel and Brass Wires,
Vienna and Ruby Draw
Plates,
Alloying Copper Wire,
Felt, Walrus Leather,
Vienna Lime, Tripoli,
&c., &c., &c.

JOSEPH STERN.

JACOB STERN.

SIMON STERN.

STERN & STERN,
Wholesale Dealers in
WATCHES & DIAMONDS
And Manufacturers of
GOLD JEWELRY,
6 MAIDEN LANE, NEW YORK.

AGENTS FOR THE CELEBRATED
MELVILLE & NEW BRIGHTON WATCHES.



ESTABLISHED 1848.

GEO. W. DUBOIS.

F. N. NAUMAN.

GEO. W. DUBOIS & CO.,

IMPORTERS OF

Watches & Optical Goods.

ALL STYLES AND QUALITIES OF
SPECTACLES AND EYE-GLASSES.

LONGINES' WATCHES AND MOVEMENTS.

The Watches in Gold, Silver and Nickel Cases of New and Handsome Patterns. The Movements fit 18 size Waltham Stem Winding Hunting Cases.

36 MAIDEN LANE, NEW YORK.

Orders by Mail Receive Prompt Attention.

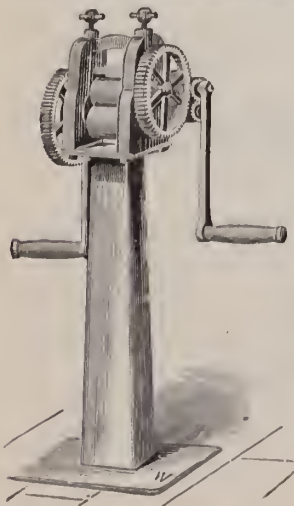

W. W. OLIVER,

MANUFACTURER OF

Hand and Power
Rolling Mills,

For Jewelers and Silversmiths.

The "Little Giant" Ring Bender

Hollow Spindle Lathes, Punching and Drop Presses, Polishing Heads, Dies, Metal Laps, Etc.

39 CLINTON STREET,
BUFFALO, NEW YORK.

Illustrated Price List mailed free upon application.

ESTABLISHED 1867.

F. JEANDHEUR, Jr.,

125 FULTON STREET, N. Y.

Gold and Silver Electro-Plating.

Mr. Jeandheur begs to notify the Trade that he has made more improvements with his new process of Electro-Plating Watches, Jewelry, Etc. By having introduced an Electro-Plating Machine instead of using the old method of plating with Chemical Battery, he is able to plate with a far greater depth of gold than before, and for wear it is equal to rolled plate. The Trade can rely on this statement, as a trial will abundantly prove, and his well-earned reputation amongst the leading houses in the Trade will be sustained.

P. S.—He also begs to notify the Trade that he has no connection with any other house or person using his name, for the purpose of soliciting work.

PRICE LISTS SENT UPON APPLICATION.

EXCELSIOR'S

PRACTICAL TREATISE ON THE

Balance Spring,

INCLUDING MAKING AND FITTING HAIR SPRINGS,
 REGULATING, ETC.

Also containing the Adjustment of Watches and Chronometers for Isochronism, Positions, Heat and Cold and Rate.

Price, \$3.50.

D. H. HOPKINSON,

42 Nassau St., New York.

JAMES J. FISHER,

DEALER IN

WATCHMAKERS' and JEWELERS' MATERIALS,

Files, Tools, Silk Guards, Watch Glasses, Spectacles, Rolled Plate, Fire Gilt, Nickel and Silver Chain, Charms, &c.

No. 697 BROADWAY,

Corner Fourth Street,

NEW YORK.

All kinds of Job Work for the Trade Promptly attended to.

The "Acme" French Clock Movement Support.
 (Pat. Nov. 1st, 1881.)

This Support is adapted to the holding in position of any French Clock Movement while regulating or adjusting, and will be found very desirable on account of its simplicity of action and the small space it occupies. To be had of any respectable jobbing house, or sent, post paid, to any address, on receipt of 60 cents.



WHEELER, PARSONS & HAYES,
 MANUFACTURERS OF
WATCH CASES, GOLD CHAINS & FINE JEWELRY

Importers of Diamonds and Manufacturers of Diamond Jewelry,
And Dealers in American and Swiss Watches,
No. 2 MAIDEN LANE, NEW YORK.

Established 1841.

Enos Richardson & Co.,
 Manufacturers of Gold Jewelry and Chains,
 23 Maiden Lane, New York.

Goods sent on approval to Dealers in any part of the U. S. upon receipt of order with satisfactory references.

San Francisco Office, 206 Kearny St., Haskell & Muegge, Agents,
 Where a full line of our goods can always be found at Eastern Prices.

Established 1828.

JACOB BENNETT & SON,
 Diamond Setters and Manufacturing Jewelers,
 No. 923 CHESTNUT STREET, PHILADELPHIA.

WE MANUFACTURE AND MAKE A SPECIALTY OF
 EVERY DESCRIPTION OF

DIAMOND MOUNTINGS,
 SUPERIOR IN DESIGN AND WORKMANSHIP.

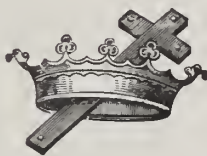

Dealers in

DIAMONDS

And all kinds of Precious Stones.

Of which we keep a Large Assortment Constantly on Hand.

Masonic Marks Society and School Badges, Made to Order Only. Designs and Estimates Furnished.
 PARTICULAR ATTENTION GIVEN TO ALL KINDS OF JOBBING.

EDWIN A. THRALL,
 1 MAIDEN LANE, NEW YORK.

—• JOBBER IN —•

American Watches, Diamonds, Fine Jewelry, Etc.

AT LOW PRICES, AND FOR CASH ONLY.

I employ no Travelers, therefore can furnish select goods of the newest designs at the very lowest market price. Every Watch warranted to keep time when delivered. The new system introduced by the American Watch Co., of selling a complete watch, will be adopted. Agent for the new Mascot Bracelet, Patented. Orders filled immediately on receipt. Repairing and Adjusting Fine Watches and Chronometers for the Trade a Specialty.

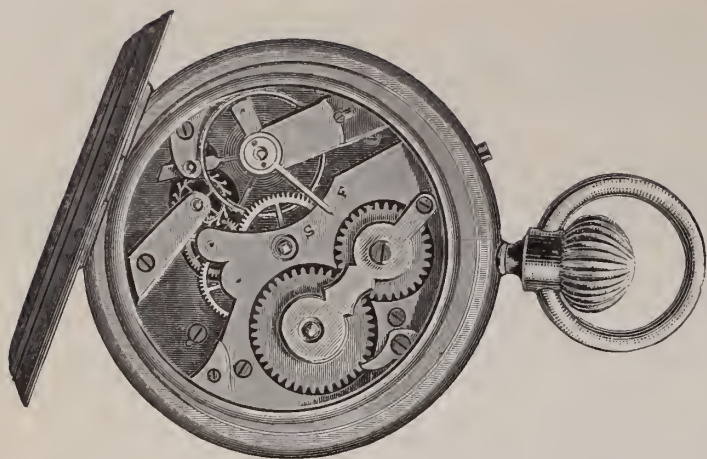

HENRY GINNEL & CO.,

31 MAIDEN LANE, N. Y.

IMPORTERS AND MANUFACTURERS OF THE

❖ PIONEER WATCH ❖

In Nickel and Silver Cases with Calendar and Chronograph Attachments. Every one a Timer and guaranteed to satisfy.

Full Line of AMERICAN MADE WATCHES Constantly in Stock.

A. J. WARNER & CO.,

WHOLESALE JEWELERS,

309 Nicollet Avenue, Minneapolis, Minn.

We carry a Large and Elegant Stock of Jewelry, Watches, Cases, Etc., Etc.

North-western Agents of the WATERBURY CLOCK CO., and carry a Complete Line of their Goods.

OUR TRADE IS EXCLUSIVELY WITH THE JEWELERS.

ESTABLISHED 1810.

VACHERON & CONSTANTIN, WATCH MANUFACTURERS,

GENEVA,

SWITZERLAND.

These celebrated Watches and Movements are adjusted to Heat, Cold and Position. Movements Filling ready made Stem-winding, Open Face and Hunting Cases of Waltham and Elgin Sizes.

SOLE AGENT IN UNITED STATES AND CANADA,

CHAS. LEO ABRY,

P. O. BOX 611.

63 NASSAU STREET, NEW YORK.

N. H. WHITE,

JOBBER IN

AMERICAN-WALTHAM WATCHES, EXCLUSIVELY.

Waltham make of gold and silver cases a Specialty. Ladd, Boss, and the Patent Screw Bezel Filled Cases to fit Waltham movements only

No. 11 MAIDEN LANE, NEW YORK.

I not only advertise that I have the Waltham Goods, but **have constantly on hand** the Largest Stock carried by any jobber in the trade. Gold Cases of all Weights and Styles. Memorandum Packages with pleasure to dealers furnishing satisfactory reference.

COMPLETE PRICE LIST TO THE TRADE.

WM. S. HEDGES & CO.,

IMPORTERS OF



COPYRIGHT SECURED. Entered according to Act of Congress in the year 1880, by WM. S. HEDGES & Co., in the Office of the Librarian of Congress, at Washington.

170 BROADWAY,

Corner Maiden Lane, New York.

CHOICE BRILLIANTS IN SINGLE STONES AND MATCHED PAIRS A SPECIALTY.

Fresh invoices of Goods in all Grades constantly arriving. Also choice parcels of exceptionally Fine Gems ESPECIALLY Selected for critical purchasers. A full line of Mounted Goods. Artistically Designed.

GOODS SENT ON APPROVAL.

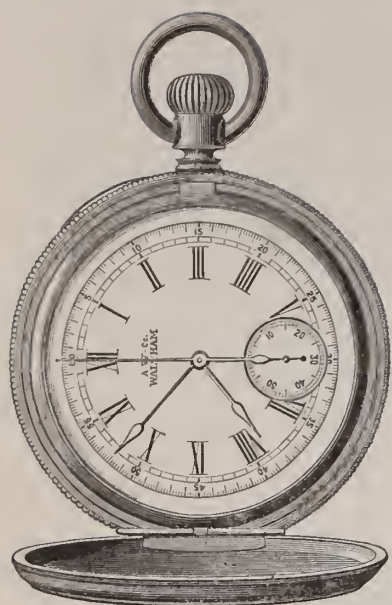

—+ NEW +—

CHRONOGRAPH

STOP WATCHES.



—+ MADE TO +—

START, STOP AND FLY BACK,

With or Without Split Seconds,

MANUFACTURED BY THE

AMERICAN WATCH CO.,

WALTHAM, MASS.



By Patented Improvements in Construction, and considerable Diminution of the Parts required, as well as by the application of American Machinery, the AMERICAN WATCH CO. has so simplified the manufacture of Chronograph Watches as to greatly reduce their cost. They can now be obtained at prices which make them the MOST DESIRABLE timepieces for Sporting Purposes, AS WELL AS FOR GENERAL USE. Dealers can depend upon these goods giving satisfaction, as they will not require the constant repairs, nor subject the dealer to the annoyance experienced in most of the foreign watches of this class. In case of accidents, Duplicates of Broken Parts can be furnished by return mail. Cased complete in 16 Size Gold and Silver Open Face and Hunting Cases. (Open Face made to wind at figure XII).

SPECIAL NET PRICE LIST,

Issued for the TRADE ONLY, will be sent on application, which will not be regarded unless accompanied by Business Card.



ANNOUNCEMENT.



The New Price List for complete 3-4 plate, 8, 14 and 16-size Gold Watches, issued under date of February 1st, 1883, by the American Watch Co., of Waltham, is now ready for distribution. We will forward a copy upon application, accompanied by business card, from any regular dealer in watches.

Jobbers who wish copies sent to their customers will please notify us by sending the names and addresses of the same, but such customers must be regular Watch Dealers. We shall take special precaution in the distribution of this list, in order to keep it out of the hands of the general public, and we beg to request that the Trade will co-operate with us in this undertaking, it being entirely in their interests.

We also beg to call particular attention to the fact that the cases quoted in this list are entirely of our own manufacture, and that we are directly responsible for the quality of the same.

By 18 K. or 14 K. or 10 K. we mean 18 K. or 14 K. or 10 K., and not 16½ K. or 12 K. or 8 K. We offer you actual value for your money.

ROBBINS & APPLETON,

NEW YORK:

5 BOND STREET.

BOSTON, MASS.:

403 WASHINGTON STREET.

CHICAGO, ILL.:

170 STATE STREET.

LONDON, ENGLAND:

HOLBORN CIRCUS.

AUSTRALIA:

SYDNEY, NEW SOUTH WALES.

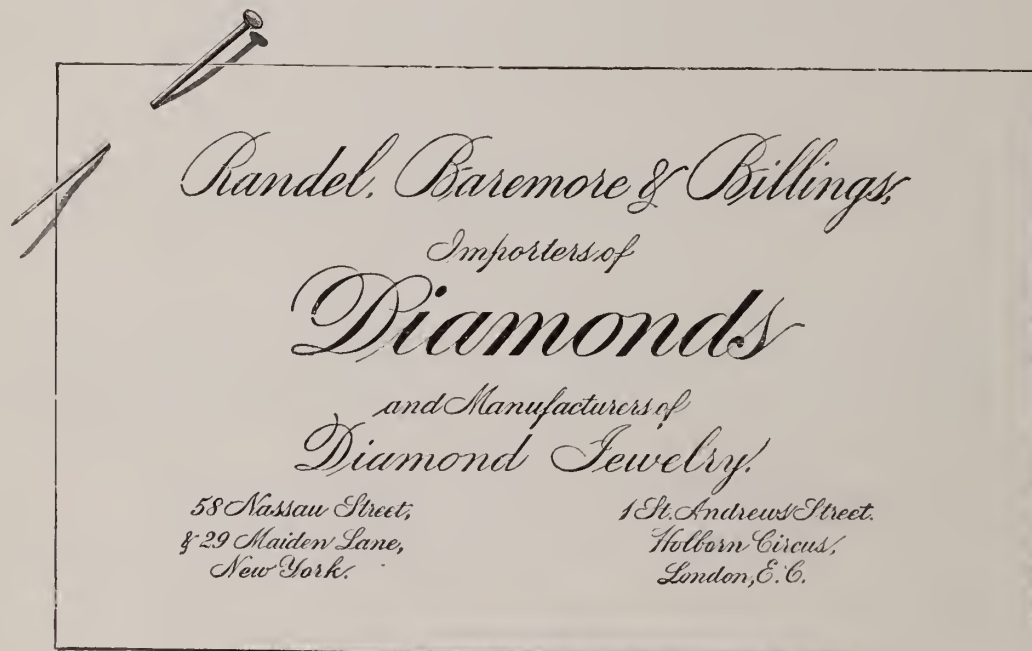

Randel, Barmore & Billings
Importers of
Diamonds
and Manufacturers of
Diamond Jewelry

*58 Nassau Street,
8-29 Maiden Lane,
New York.*

*1 St. Andrews Street,
Holborn Circus,
London, E. C.*



SINNOCK & SHERRILL,
THE LARGEST MANUFACTURERS OF SEAL AND STONE RINGS
 (Making that a Specialty and Manufacturing Nothing Else.)
IN THE UNITED STATES.

The first and most important thing to be looked after in buying Rings is the **Quality**. If that is not as represented, customers are lost, and much trouble may follow.

Dealers buying our Rings, will find each one which is sold for 14 K. stamped $\frac{584}{1000}$ fine, or when there is not room for that, 14 K. fine or 14 K., but never 14 alone, and all are guaranteed to assay $\frac{584}{1000}$ fine, which is a fraction over 14 K. by a United States Assay.

The second most important thing is the **Design**. If the design is inappropriate or ungainly, the sale of the Ring cannot be effected, no matter how fine the quality; and thirdly, perfection must be sought after in the **Finish** of the Ring.

If the stone is wrongly or unevenly set, if the shank is imperfectly soldered, badly engraved or poorly polished, the quality goes for nothing, the beauty of the design is lost and the Ring cannot be sold. Combining the most complete machinery with the best skilled labor, our customers will find the three above objects sought after by us and **GENERALLY** attained.

New York Office, No. 3 MAIDEN LANE.

Factory, NEWARK, N. J.

Western Office, CHICAGO, ILLS.

M. FOX & CO.,

Practical Lapidaries and Importers of

DIAMONDS.

Rubies, Sapphires and Fancy Gems.

→ **PEARLS, TURQUOISE, INTAGLIOS, ONYX, AMETHYST, ETC.** ←

No. 1 MAIDEN LANE, NEW YORK.



181



193



PATENT APPLIED FOR
193

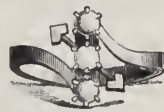

214



218



219



812

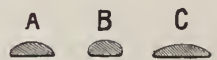

THE ABOVE CUTS ARE THREE DIFFERENT SHAPES IN THE SAME WEIGHT OF PLAIN RINGS. TO BE USED IN ORDERING.

J. B. BOWDEN & Co.,

MANUFACTURERS OF SOLID RINGS

OF EVERY DESCRIPTION.

No. 1 MAIDEN LANE, cor. Broadway, NEW YORK.

LEON JEANNE.

PAUL JEANNE

JEANNE BROTHERS

MANUFACTURERS OF

DIAMOND MOUNTINGS,

AND RICH JEWELRY.

No. 1 MAIDEN LANE, NEW YORK

Designs Furnished and Estimates Given.

JEANNE BROS PAT. DIAMOND SETTINGS.

A PLATINUM SETTING WITH A GOLD SURFACE OUTSIDE

IN THIS WAY THE REFLECTION OF COLD THROUGH THE DIAMOND IS ENTIRELY AVOIDED.

PAT. AUG. 15TH 1882



347R.



278D.
Patented.



389.
Patented.



351D.



251.

SPECIAL LINE INITIAL RINGS, SEALS, ETC.

INCURSTED—DIAMOND—PEARL—OR RUSTIC LETTERS.

DESIGNS PATENTED.

Illustrated Plate sent to Dealers upon request.

HENRY C. HASKELL,

MAKER OF FINE GOLD JEWELRY.

No. 12 John St., New York.

Goods sent on approval to any part of the country, upon receipt of satisfactory references.

House Established 1837,

Successor to J. A. ABRY.

CHARLES LEO ABRY,

Importer and Manufacturer of all Grades of

SWISS WATCHES,

And dealer in Elgin, Springfield, Ill., and Lancaster Movements.

Specialties in Gilt, Nickered and Nickel Stem-Winding Movements, Ladies' Sizes, to Fit Elgin Cases.

IMPORTER OF THE FOLLOWING WELL-KNOWN SWISS WATCHES:

Geo. Mayor, A. Ames Droz, Chas. Estine, F. Richard, Huguenin Nardin and Ernest Duval, as well as all kinds of Watches for the Jobbing Trade, including Nickered, Open-Face and Hunting Stem-Winders, Anchors and Cylinders, 16, 18 and 19 lines. Silver Key and Stem-Winders, Hunting and Open Face, all sizes and qualities, from low to highest grades. Silver and Nickel 13 and 14 line Watches for Chatelaines, Gold, Silver, Nickel & Rolled Plate Chatelaines of good styles & designs always in stock.

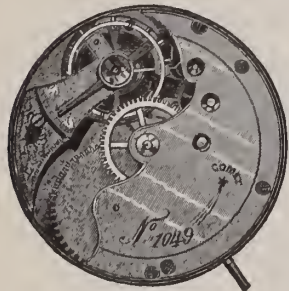

COMET.

SOLE IMPORTER.

Fits 8 Size Elgin Cases.

P. O. Box 611.

63 NASSAU STREET, NEW YORK.

Factory, Neuchatel, Switzerland.

JOHN A. RILEY & CO.,

MANUFACTURING JEWELERS,

NOS. 7 & 9 BOND STREET,

NEW YORK.



A. BERNHARD & CO.
 MANUFACTURERS OF
DIAMOND & FINE JEWELRY
 ORNAMENTAL HAIRWORK

OFFICE & FACTORIES
 3, 4 & 5 FLOOR,
 P. O. BOX 1111.

2
**MAIDEN LANE,
 NEW YORK.**



LUDWIG LEHMANN,

MANUFACTURER OF

JEWELERS' FINDINGS,

Paper Jewelry Boxes, Jewelers' Cards, Cotton of all Shades, a Rich Assortment of Cases in Plush, Velvet and Morocco.

Also Importer of the Celebrated Grass Bleached Tissue Paper, Mill 39.

Specialties:—Imitation Morocco Boxes and Cases, Plush and Satin Lined.

122 FULTON STREET, near Nassau, NEW YORK.

THE HOPKINS LATHE.

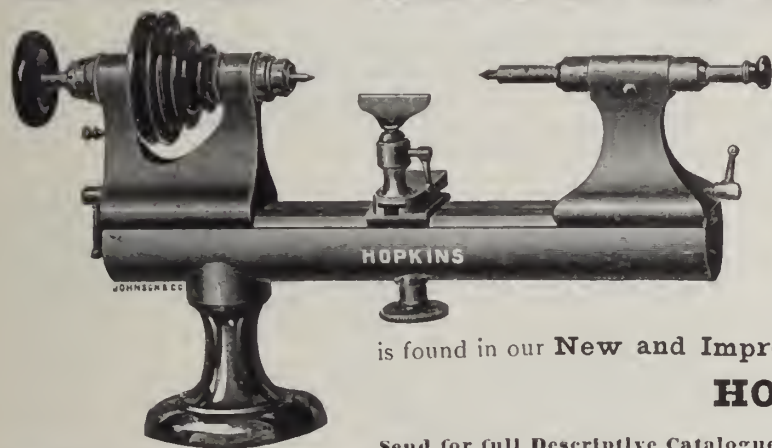

These Lathes are Unsurpassed in Quality and Workmanship.

In Special Features of Practical Value, peculiarly adapted to Watch Repairing, they excel all others. The attachments are made **interchangeable** in all the sizes.

The only absolute substitute for wax, in Watch Repairing,

is found in our **New and Improved Pivoting Chuck**, represented in the above sectional view.

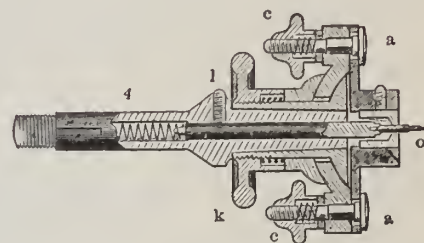

HOPKINS WATCH TOOL CO.,

WALTHAM, MASS.

Send for full Descriptive Catalogue.

S. KOHN & CO.,

43 MAIDEN LANE,

NEW YORK.

*Manufacturers of
Fine Morocco, Plush and
Velvet Boxes.*

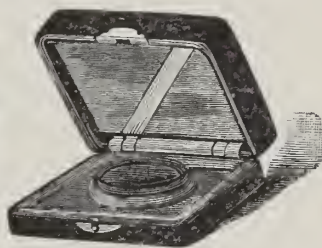

*Trays and Silverware
Boxes of all Description
Made to Order.*

A Full Line of Boxes Constantly on Hand, and Samples sent on Selection.

ORDERS FROM THE JOBBING TRADE RESPECTFULLY SOLICITED.

1883



New Goods in Novelties and Staple Lines.

LOW PRICES

LUDWIG & NOLTING

Cincinnati's Exclusive Wholesale Jewelers.

AND ALL GOODS FULLY WARRANTED.

THEUERNER & CHURCH, MANUFACTURERS OF FINE RINGS, No. 9 MAIDEN LANE,

FACTORY, COR. MULBERRY & DURAND STS., NEWARK, N. J.

NEW YORK.

ESTABLISHED 1859.

RINGS A SPECIALTY.

BRYANT & BENTLEY,

12 MAIDEN LANE,

Up-Stairs,

NEW YORK.

AMONG OUR LATEST PATTERNS OF FINE SOLID RINGS ARE



587



591



584



504



589



490

No. 587—Made in Topaz and Amethyst. No. 591—Cluster of Garnets, Doublets or Turquoise, with Pearls and Diamonds. No. 584—Cameo or Garnet with Pearls and Diamonds. No. 504—Misses' Turquoise Rings. Nos. 490 and 589—Represent two patterns only of our Engraved Band Rings.

We also continue to make a full line of our well known 16 K. HARD SOLDER RINGS.

Goods sent on approval to responsible parties.

ESTABLISHED 1874.

JOSEPH P. WATHIER,

Successor to JOSEPH P. WATHIER & BRO.,

178 WEST MADISON ST, CHICAGO, ILL.

WHOLESALE JEWELER & WATCHMAKER & JEWELER FOR THE TRADE,

Changing of Key Winding Movements into Stem Winding and Hand Setting,

AND MAKING STEM WINDING PARTS A SPECIALTY.

All Work Intrusted to me will receive PROMPT ATTENTION, and Satisfaction Warranted, at Prices Always the Lowest.

HENRY ZIMMERN,

IMPORTER OF

Watch Materials,

TOOLS,

AND OPTICAL GOODS,

No. 8 Maiden Lane, New York.

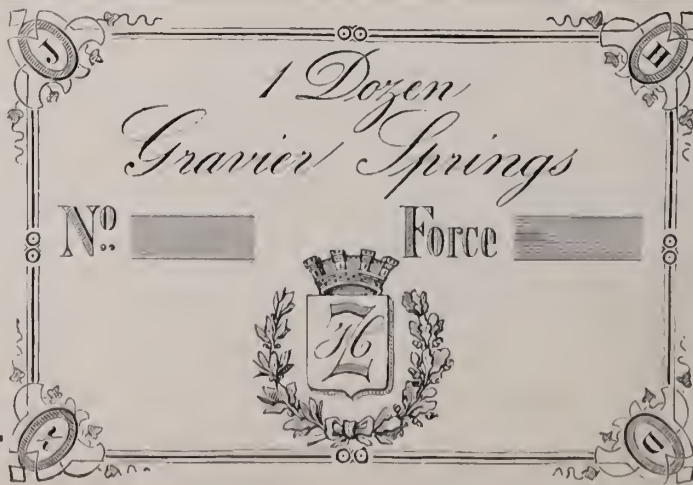

SOLE AGENT

FOR THE CELEBRATED

GRAVIER

MAINSPRINGS.

The cut is a fac simile of trade mark with my monogram on wrapper, adopted by me to prevent the trade from being imposed upon with imitation springs. A brass tag attached to each spring indicates the number and strength according to Dennison's United States Standard Gauge. These Springs are to be obtained at all leading Jobbing Houses.

WHITE METAL CHAINS A SPECIALTY.

E. AUG. NERESHEIMER
& Co

IMPORTERS
of

DIA MONDS

21 MAIDEN
LANE
NEW YORK

NO 66 SARPHATI STRAAT
AMSTERDAM HOLL.



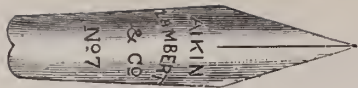

AIKIN, LAMBERT & CO., 23 MAIDEN LANE, NEW YORK.

MANUFACTURERS OF

GOLD PENS, PENCIL CASES, HOLDERS, PENCILS, TOOTH PICKS

AND LATEST "NOVELTIES" IN PENCIL CHARMS.



"GRAVITY" PENCIL.

In addition to our Large Assortment of Gold Pen and Pencil Goods, we offer this season many *New* and *Novel* Patterns, all of our *Exclusive* Manufacture and Sale.



Our Line of Richly *Ornamented Engraved* Holders in all styles, suitable for *Presentation* purposes, show many *Patterns New* to the Trade.



New Styles of Pencil Charms in *Solid Gold*, *Silver* and *Rolled Plate*.



Our Line in *Tooth Picks* embraces the *Latest* Designs in *Solid Gold*, *Silver*, *Pearl*, *Celluloid* (*Fancy* and *Plain*) and *Plated*.



Goods Sent on *APPROVAL* when desired.

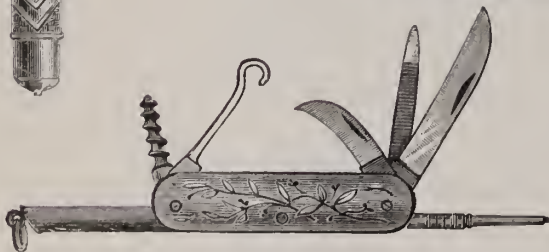

SEND FOR
Catalogue and Price List.



—:o ALSO IMPORTERS AND JOBBERS OF ALL GRADES OF o:—

WATCHES.

Including a Large Variety of *Desirable* Metal Cased *Stem-Winders*, and the *best* Low-Priced "*Chronograph*" Watch in the market

Agents for *AGASSIZ* Movements fitting 8 and 16 Size *Elgin* Cases, and the *LONGINES* Movements fitting 18 Size *Waltham* Cases. Sole Agents for *PAUL BRETON* Celebrated *Geneva* Watches.

Jobbers of all kinds of *AMERICAN MOVEMENTS AND CASES*, including the *Dueber* and *Keystone* *Silver* Cases, and *Boss'* and *Ladd's* *Filled* Cases.

Manufacturers of *STONE RINGS*, all leading kinds, *Band Rings*, &c. *Gold* and *Silver* *Thimbles*, *Plain*, *Chased*, *Octagon*, &c. *Bracelets*, a large assortment in *Gold* and *Plate*. *Gold* and *Plated* *Chains*, *Locketts*, *Seals*, &c. A large variety of new and stylish *Patterns* in *GOLD* and *PLATED JEWELRY* are constantly being added to our stock. *Prompt attention to Orders and Repairs.*

JAS. C. AIKIN,
H. A. LAMBERT,
J. B. SHEA,
D. F. FOLEY.

Western Branch, 113 EAST MADISON STREET, CHICAGO, ILLS.

Falkenau Oppenheimer & Co.
Importers of Diamonds



40 Maiden Lane N. Y.

Post Office Box 3314.

W. WESLEY MOORE

hopes to add to his many friends in Ohio, Tennessee, Arkansas, Kentucky, Missouri, Illinois, Iowa, Kansas, Nebraska, Colorado, New Mexico, Wyoming, Utah, Montana, Nevada, California, Arizona and Oregon.

NEW DESIGNS.

Mr. BRADLEY

will call at regular intervals in

Illinois, Wisconsin,
Michigan, Minnesota,
Dakota, Montana,
Iowa and Indiana.

Headquarters,
Chicago, . . . Illinois.



We, the undersigned, representatives of the above well-known house, would announce to our respective friends that we will show them this Spring many new attractions, in addition to our usually large and varied stock.

We aim to merit your continued patronage and confidence.

Very Respectfully,

W. Wesley Moore
Mr. Bradley
J. L. Clark
J. C. Address
H. C. Barnum
H. S. Colyer

J. C. ADDRESS

will continue to call on his friends in Maryland, Delaware, District Columbia, Virginia, W. Virginia, North Carolina, South Carolina, Georgia, Florida, Alabama, Mississippi, Louisiana, Texas Tennessee, Kentucky and Ohio.

J. L. CLARK

hopes to receive the favors of his patrons in

New York,

Massachusetts,

Connecticut

and Vermont.

H. C. BARNUM

will renew his many acquaintances in

Massachusetts,

New York, Ohio,

Indiana, Illinois

and Michigan.

Headquarters,

Syracuse, . . . N. Y.

ATTRACTIVE GOODS.

FRESH STOCK.

LOW PRICES.

H. S. COLYER

will represent the house in

Massachusetts,

Maine,

New Hampshire,

New Jersey,

Pennsylvania,

Ohio and

West Virginia.



WHITING M'F'G CO.,

SILVERSMITHS,

BROADWAY & FOURTH STREET,

NEW YORK.

THE CLIMAX REVERSIBLE WATCH CASES,

Manufactured by the Northwestern Watch Case Co., of Rockford, Illinois.

Patented April 3d, 1883, No. 275,251.



OPEN FACE.



REVERSIBLE



HUNTING.

ABSOLUTELY DUST PROOF AND POSSESSING REAL MERIT.
A MARVEL OF INGENUOUS MECHANISM.
 DESCRIPTIVE CIRCULARS FURNISHED UPON APPLICATION.

CLEMENS HELLEBUSH,

MANUFACTURER, IMPORTER AND WHOLESALE JEWELER,

Dealer in everything required by the Jewelry Trade.

DIAMONDS.—Dealers will find in my stock an assortment of Diamonds unequalled in the West, embracing a choice variety of loose and mounted Stones in all qualities.

WATCH CASES.—In Gold and Silver, of all makers, to fit American Movements.

WATCH MOVEMENTS.—Include always a full stock of Waltham, Springfield, Hampden and Howard, together with a large assortment of fine and low-priced Swiss Watches.

SILVER PLATED WARE.—I have an unusually fine assortment of the choicest patterns of Flat and Hollow Ware of the best known manufacturers.

SOLID GOLD AND ROLLED PLATE JEWELRY.—This department is replete with Staple Goods and Novelties.

FRENCH CLOCKS.—Of our own importation, including all grades, with prices exceedingly low.

AMERICAN CLOCKS.—I am the General Agent in Cincinnati for the celebrated Seth Thomas Clocks, a full line of which will always be found in stock.

TOOLS AND MATERIALS.—In this department will be found everything required by Watch Makers.

Illustrated Catalogues sent to Dealers only upon Application.

CLEMENS HELLEBUSH,

77 West 4th Street,

CINCINNATI, O.

Important Notice to the Jewelry Trade.

FINDING that many of the general designs for art wonders given in the pages of THE ART AMATEUR are used freely by jewelers, and recognizing that no publication in this country furnishes special designs for that very important body of art workers, the publisher has determined to supply the want. With this view, he has engaged the services of Mr. Henri L. Bouché, (with Messrs. Tiffany & Co.) one of the best jewelry designers in the United States. Beginning with the May number, this gentleman will furnish exclusively for publication in this magazine practical models for Pins, Bracelets, Bangles, Chains, Locketts, Pencil Cases, etc.

A complete series of very artistic Monograms, including the most varied simple combinations, is now running through THE ART AMATEUR, at least a page of them being given each month.

In addition to the original designs for jewelry, carefully selected designs will be given from the best foreign sources.

The May number (which will be sent to any address on receipt of 35 cents,) contains, besides its usual wealth of information relating to art matters in general, fourteen original and very attractive designs by Mr. Bouché, all easy of execution. The first lace pin would be appropriate for an engagement pin; the center is a Roman Coin, but a cameo or a fine enamel could easily be used instead; two pearls and two diamonds form part of this jewel, the whole being entwined with a bow of chased gold. The locket next to it is in the shape of a fruit with the leaves as ornaments, the whole chased on gold; the ground is rough, but produces a very rich effect. Silver

lace pins will be much in demand for summer wear. The grass-hopper design, oxidized of different colors, would have a pleasing effect on a light dress. The two scarf pins may have a ground of dark blue champlevé enamel, or of silver with the ornament in soft enamel. The central design is for a pendant attached to a necklace, and is made of diamonds and gold. Of the two lozenge-shaped pendants, one is made of gold of different colors, with laurel leaves as ornaments; in shape it is somewhat Gothic, and entirely new. The other is of a Roman character, with a beautiful coin in the center. Both should be chased. The bracelet, through which passes a vine of flowers, would make an attractive wedding present, the gold chain being an emblem of marriage and the flowers of happiness. The two other bracelets may be executed in either gold or silver with fine effect. The two pairs of gold sleeve-links are entirely new in design and easily made. Designs appropriate for bridesmaids are often asked for. The pin made of the links of a chain, ornamented with orange blossoms, would answer very well for this purpose.

Some very interesting illustrations of jewelry, prepared especially for the Vanderbilt ball, are given in the May number; and also a page of valuable suggestive bits taken from the most artistic models and useful to the jeweler for a variety of purposes.

In the June issue of THE ART AMATEUR, Mr. Bouché's designs will include ideas for badges, class-pins and rings.

Subscription, \$4.00 a year; single copies, 35 cents.

MONTAGUE MARKS, Publisher, 23 Union Square, New York.



13 Maiden Lane,
NEW YORK.

FRANK S. KENNEDY,
Manufacturer and Wholesale Dealer in
JEWELRY
OF EVERY DESCRIPTION.



13 Maiden Lane,
NEW YORK.

In addition to my stock of Jewelry, which is complete in all lines of Gold, Silver and Roll Plate, I am now making a Full Assortment of

THIMBLES,

in Solid Silver, 10 karat and 14 karat Gold. These Thimbles are Superior in Finish to any now in the market, and are as near perfection as long practical experience can make them. Will send Samples if desired.

The Assortments of Jewelry I send on Memorandum for Special and Stock Orders have an increasingly high reputation.

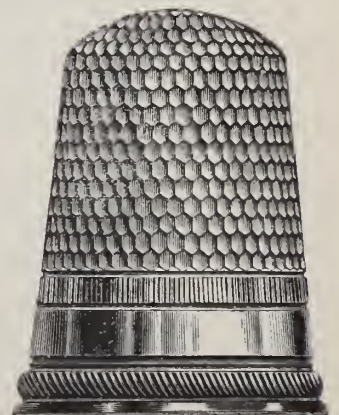
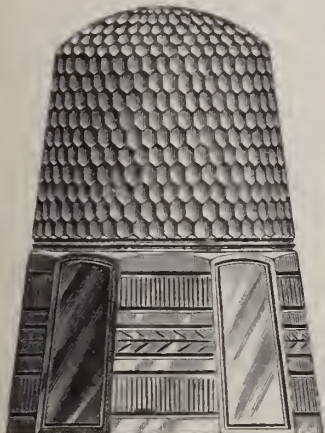

T H E

E. HOWARD WATCH AND CLOCK CO.,

—MANUFACTURERS OF—

Fine Stem-Winding Watches,

FINE REGULATORS, OFFICE CLOCKS, TOWER CLOCKS,

And Electric Watch Clocks.



LADIES'
6 Size.

**STEM-WINDING
AND**



GENT'S
16 Size.

**Stem-Setting
Movements.**



GENT'S
18 Size.

114 TREMONT ST., BOSTON.

29 MAIDEN LANE, New York.

J. W. J. PIERSON, Agent.



WILLEMIN WATCH CASE CO.,

109 Sands Street, Brooklyn, N. Y.

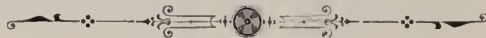

Our Engine Turned (Jurgensen Cases), a Specialty with us, have achieved a high reputation in the Trade, and are, without any exception, the Best Made and Cleanest Cut Engine Turned Cases made.

We ask you to compare these Cases with those of any other manufacture, as they are made to stand the closest criticism. We also invite especial attention to our Raised Gold Ornamentation Work, Escalloped, Enameled and other styles of decoration.

NEW YORK OFFICE, 11 MAIDEN LANE, N. Y.

ROGERS, SMITH & CO.,

MANUFACTURERS OF

Electro Gold
AND
Silver Plated
Ware.



SALESROOMS:

46 EAST 14th STREET,

UNION SQUARE, N. Y.

FOR THE TRADE ONLY.

FACTORY, - - - MERIDEN, CONN.

INVALUABLE.



Patented March 20th, 1883.



SELF SIZING,

WITHOUT CUTTING or SOLDERING.

Simple, Durable, Handsome, Inexpensive.

MANUFACTURED BY

R. HENRICH,

Manufacturer of SEAL and STONE RINGS in all Varieties.

35 Maiden Lane,

NEW YORK.

FOR SALE BY ALL JOBBERS.

ESTABLISHED 1844.

DENNISON MFG CO.,

BOSTON, NEW YORK, PHILADELPHIA, CHICAGO, CINCINNATI AND ST. LOUIS.

JEWELERS' FINDINGS.

PAPER JEWELRY BOXES IN ALL STYLES AND QUALITIES. IMITATION MOROCCO BOXES, SATIN LINED. TAGS, JEWELERS' CARDS, PINK AND WHITE COTTON, &c., &c.

MOROCCO CASES.

Manufacturing in our own Shops Every Description of Morocco, Plush and Velvet Jewelry and Silverware Cases in large quantities, we are enabled to sell lower than other goods of equal quality can be offered, and we carry in all our Stores FULL Stock of our whole line.

Catalogue on Application.

THE LATEST DESIGN IN SEAL RINGS.

THE "PRINCESS," THE "PRINCESS," THE "PRINCESS,"

Design Patented, No. 13,840.

Design Patented, No. 13,840.

Design Patented, No. 13,840.

RAISED INITIALS IN DIAMONDS on a Curved or Dome Shaped Stone.

The demand from all over the country for these Rings has led Manufacturing Jewelers

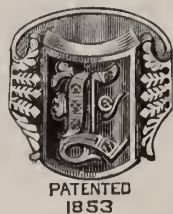

generally to carry them. The Patent consists of a RAISED INITIAL on a curved or dome shaped stone, regardless of style of shank. Any dealer handling this Ring, unless stamped "Patented April 3, 1883," renders himself liable to prosecution.

The growing popularity of the "Princess" Ring renders them the most desirable goods for dealers to carry. They are Unique, Beautiful and Attractive, entirely new and moderate in price.

FOR SALE BY MANUFACTURERS AND JOBBERS.



KREMENTZ & CO.



MANUFACTURING JEWELERS,

REMOVED

TO

182 BROADWAY, COR. JOHN ST.,

NEW YORK.

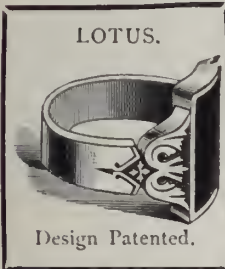

Elevator Entrance, - John Street.



LONGINES CHRONOGRAPHS

Fly-Back & Horse-Timing



STEM-WINDING

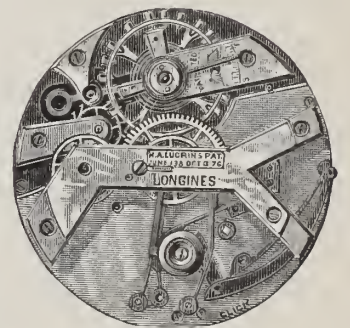

The most reliable, accurate and substantial LOW PRICE Timing Watch made. The improved method of mechanism in their construction renders these goods superior to any low price Timing Watch in the market, and the Best Selling Goods offered to the Trade.

J. EUGENE ROBERT,

30 MAIDEN LANE,

NEW YORK.

FOR SALE BY THE LEADING JOBBERS.

Duplicate Parts and Finished Material for these Goods always in Stock.



GEO. H. RICHARDS, JR.

383 WASHINGTON STREET,

BOSTON, MASS., U. S. A.



AMERICAN MOVEMENTS AND CASES A SPECIALTY.

We Guarantee to have ALL GRADES in Stock.

MOVEMENTS.

WALTHAM.

SPRINGFIELD, ILLS.

HAMPDEN.

ELGIN.

HOWARD.

→: CASES. :←

•GOLD•

•FILLED•

•SILVER•

WALTHAM.

"BOSS."

WALTHAM.

DUEBER.

CROWN.

DUEBER.

BROOKLYN.

LADD.

FAHYS.

G. H. R., Jr.

KEYSTONE.

Watches, Jewelry and Silver Plated Ware. Rogers & Bro.'s Flat Ware.

HOLLOW AND FLAT WARE SOLD AT MANUFACTURERS' DISCOUNTS.

Our Stock is positively the Largest, Finest and Best Assorted of any Jobbing House in the Country. All Orders Promptly Executed.

GEO. H. RICHARDS, Jr., 383 Washington Street, Boston, Mass.



Our Catalogue of FRENCH MARBLE GONG CLOCKS is now ready, and will be sent to the trade ONLY on application.

LE BOUTILLIER & CO.,

Importers and Jobbers,

3 Union Square,

NEW YORK.

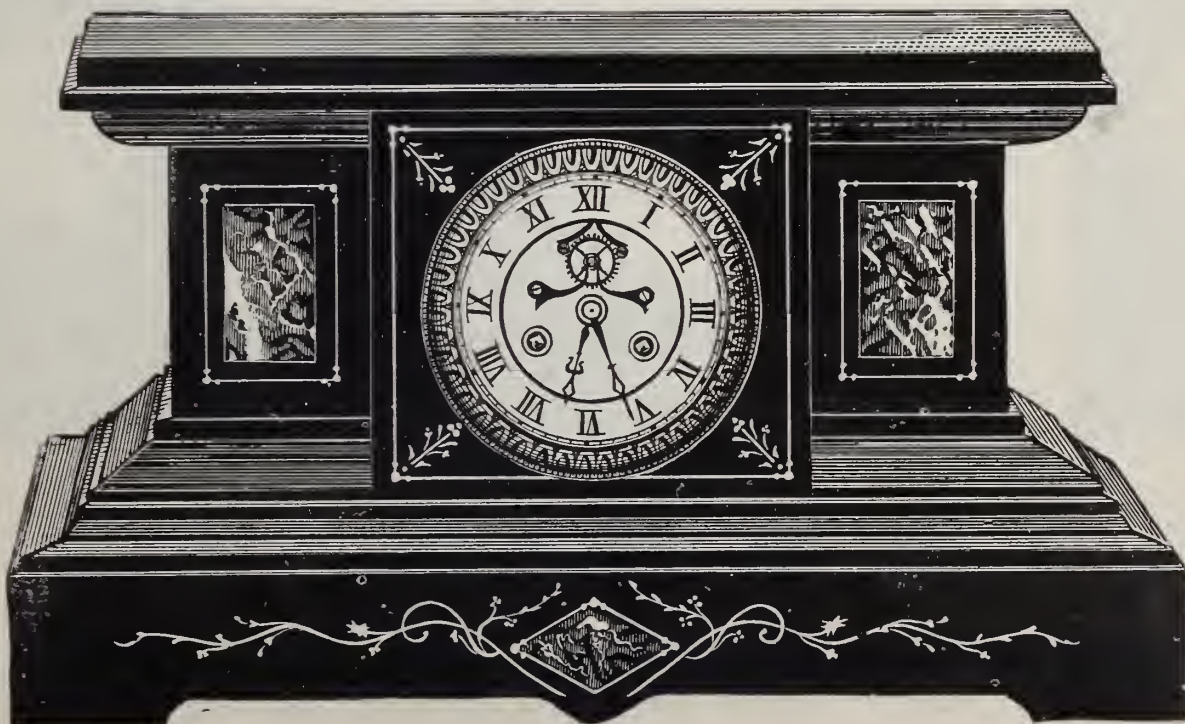

TAYLOR & BROTHER,
676 BROADWAY, NEW YORK.
IMPORTERS OF
Diamonds and other Precious Stones,
Clocks, Bronzes and Fancy Goods,
AND
MANUFACTURERS OF DIAMOND JEWELRY.



*Especial attention is directed to our Recent Invoices of FRENCH CLOCKS,
Sold at EXTREMELY LOW PRICES.*

ORIGINAL PACKAGES OF DIAMONDS CONSTANTLY ARRIVING.

L. A. CUPPIA,

Manufacturing Jeweler,

19 Union Square, N. Y.

SILVER CANE HEADS,

A Large and Comprehensive Assortment of New and Original Designs.

AND IMPORTER OF



Embracing a Large and Varied Assortment of Popular Designs.



SILVER BRACELETS A SPECIALTY.

SELECTION PACKAGES SENT ON APPROVAL.

E. E. KIPLING,

— IMPORTER OF —

PRECIOUS AND IMITATION STONES,

No. 6 Maiden Lane, New York.

For the protection of the trade I find it necessary to issue the following TRADE MARK.

Very Important to Jobbers and Retail Jewelers.

In buying White Stone Jewelry, be sure to get "Patent Foil Solid Metal Back Rhine Stone Brilliant." The Cards must be stamped as above. The advantages over the PAINTED FOILS ARE:

TRADE MARK.



which will hereafter be embossed or printed on all cards containing Jewelry in which is set my Patent Foiled Solid Metal Back Rhine Stone Brilliants, in place of the below stamps, which were formerly employed and which have been ABOLISHED.

- They are more Durable.
- are not affected by washing or dampness of air.
- retain their Lustre.
- preserve their Purity of Color.
- are sold at the same price as the Painted Foils.
- are sure to give satisfaction.

See that all the Jewelry Cards are Stamped with my Trade Mark.

All violations of my rights, whether under my patent or my trade mark, will be prosecuted to the full extent of the law.

My customers are respectfully requested to inform me of any infringements that may come to their knowledge, so that I may be the better able to protect them from unlawful competition.

PATENT FOILED SOLID METAL BACK
RHINE STONE BRILL'S.
PATENTED FEB. 23, 1882.



PATENT FOILED
SOLID METAL BACK
RHINE STONE BRILL'S.
PAT. FEB. 23, 82.

All Jewelry containing my Patent Foils, made after this date, will bear my TRADE MARK.

E. E. KIPLING.

THE WINDSOR SLEEVE LINK.

PATENTED MARCH 13, 1883.

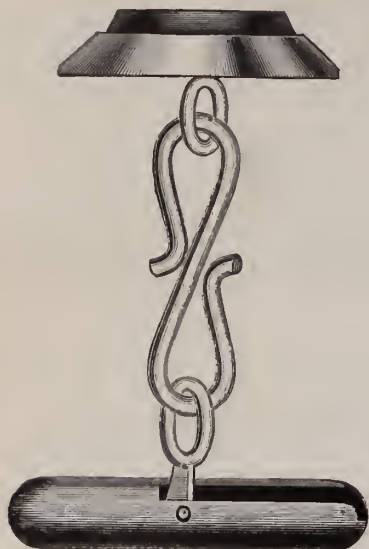

This Cut represents the Button with the Eye properly adjusted in the center of the Bar.

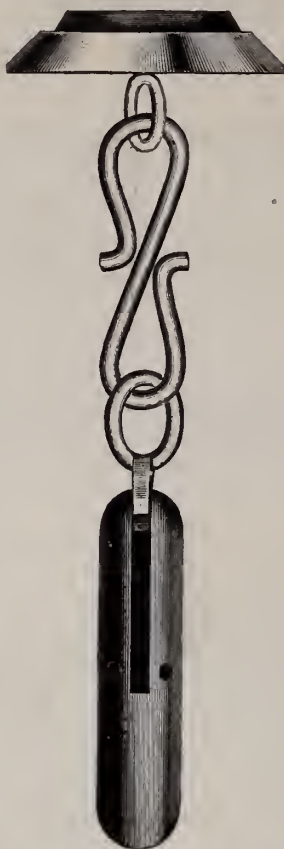

OPENED.

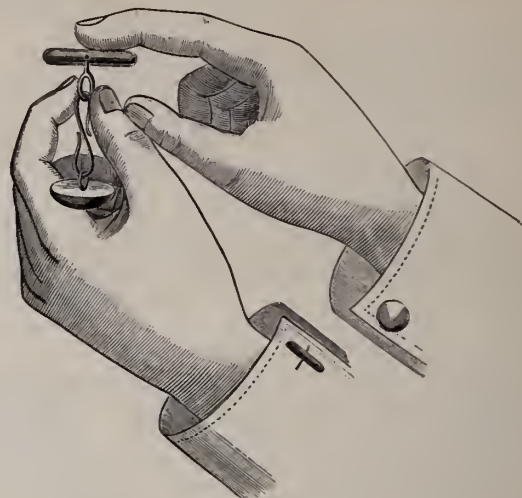

This Cut represents the proper manner of detaching the Eye and sliding the same to the end of the Bar.

SOLD BY ALL LEADING JOBBERS.



Standard Marine Chronometer, FOR KEEPING CORRECT TIME.

JOHN BLISS & CO.,
Standard Marine
 CHRONOMETERS AND TRANSITS
 FOR WATCHMAKERS' USE.

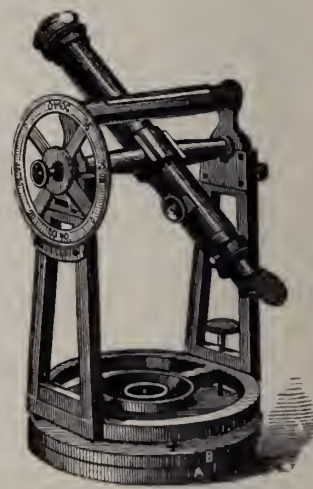

No. 10.

128 FRONT STREET, NEAR WALL STREET, NEW YORK.

IMPORTANT NOTICE.—These Transits are readily set in position without the aid of strictly correct time as a basis for that purpose. Printed instructions, easily understood, accompany each Instrument, and no calculations are required preliminary to setting in position.

As a trial only is required to insure unqualified approval, we are induced to make the following **LIBERAL OFFER**:—On receipt by us of satisfactory reference, and 10 per cent. of the price, we will send one of the foregoing Transit instruments, on hire or trial, for one month, with full printed instructions for setting up and using the same, and if purchased after trial, we will allow the whole hire to apply in part payment, and sell the Instrument on approved note at four months for the balance. Special terms for payment by installments, after trial, on application. We do not make this offer merely to hire these instruments, but to insure a trial with a view to sales, the hire received being only sufficient to cover the cost of repolishing in case they are returned. Send for Illustrated Circular giving full description.

JOHN BLISS & CO., 128 Front Street, (between Wall and Pine Sts.) New York.

LOUIS KAHN.

MOSES KAHN.

SAMUEL H. LEVY.

I. W. FRIEDMAN.

L. & M. KAHN,

IMPORTERS OF

Watches, Diamonds & Precious Stones,

10 MAIDEN LANE, NEW YORK.

11 Corrairie, Geneva, Switzerland.

17 Rue de Chateaudun, Paris.

WATCHES,

Stem and Key-Winding, from the Lowest Priced Nickel and Silver to the Finest Gold and Complicated.

A Full Assortment of these Goods always in Stock.

DIAMONDS,

Loose and Mounted, in all Sizes and Qualities.

Gold, Silver, Nickel and Celluloid Chatelaines in Great Variety.

STANDARD DUST-PROOF WATCH KEYS.

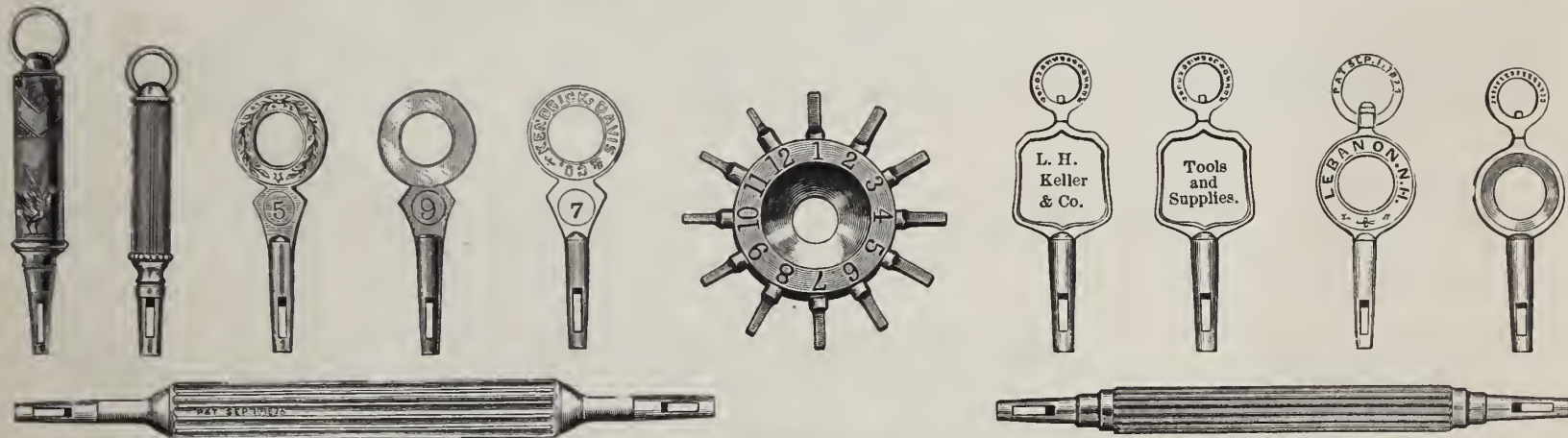

FOR SALE BY



THE TRADE.

KENDRICK & DAVIS,

Sole Owners and Manufacturers, Lebanon, N. H.

ILLUSTRATED CATALOGUE AND PRICE LIST SENT ON APPLICATION.

"The Waterbury." The New "Series B,"

NEW SERIES B.

Bezel Off,

Showing Index Plate and Regulator.

With FULL DIAL and SOLID PLATES.

In this new SOLID PLATE movement the position of the regulator has been changed; it will be found projecting beyond the plate, immediately under the bezel. The FULL DIAL enables the position of the hands to be readily seen.

The danger of injuring the Hair Spring in regulating is obviated in this new movement.

SERIES A.—Open Dial, Skeleton Plates, - - \$48.00 per doz.

SERIES B.—Full Dial, Solid Plates, - - - 48 00 "

Discount to the Trade.

We can supply either Pattern as ordered.

WATERBURY WATCH CO.,

WATERBURY, CONN.

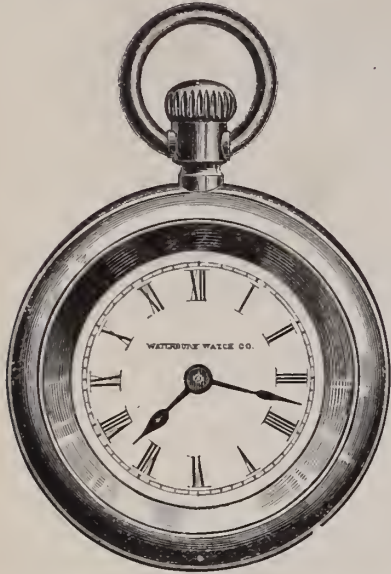

NEW SERIES B.

Solid Plates and Full Dial.



NEW YORK OFFICE, 52 MAIDEN LANE.

GEO. MERRITT, GENERAL SELLING AGENT,

To whom all Orders and Correspondence as to Prices and Terms should be addressed.

FOR SALE BY DEALERS GENERALLY.

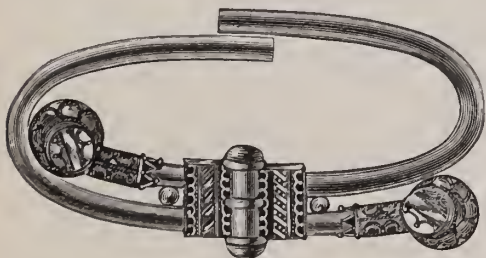

225

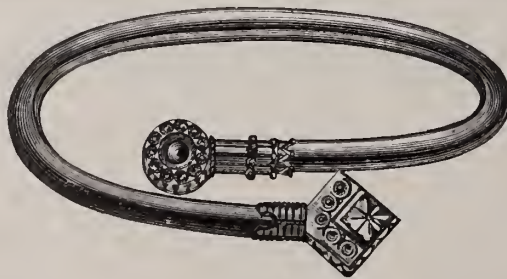

214

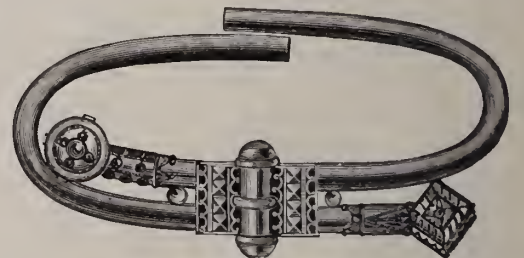

222

ELLISON & VESTER'S PATENT

BAND AND BANGLE FINE ROLLED PLATE

BRACELETS,

For Sale by Every Jobber.

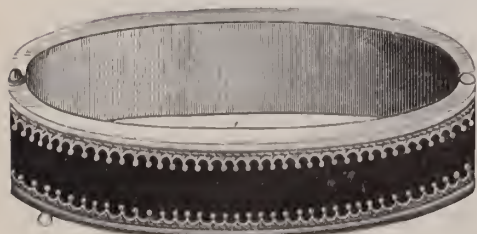

179



213

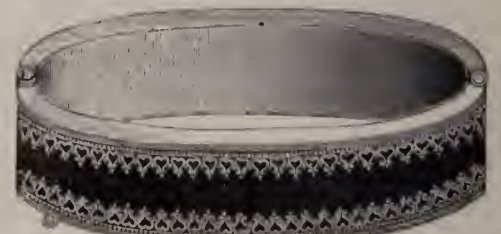

178



Design Patented.

STERN BROS. & CO.,

No. 30 Maiden Lane, New York,



Importers of Diamonds,

MANUFACTURERS OF FINE JEWELRY.

Jobbers in American Movements of all grades, Gold & Silver Cases, Gold & Plated Chains.

THE FOLLOWING ARE OUR SPECIALTIES:

SEAL and STONE RINGS. GENT'S LOCKETS. The most complete and largest line of GOLD INITIAL RINGS and LOCKETS made in the United States. The celebrated DOUBLE CROWN Plain Filled Rings, which are universally acknowledged the MOST RELIABLE in the market. Made in seven different widths.



No. 00

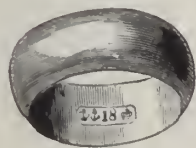

No. 0



No. 1



No. 2



No. 3



No. 3½



No. 4

EVERY RING IS WARRANTED TO GIVE SATISFACTION.

Goods sent on selection to Dealers upon application with satisfactory reference.

PATENT IMPROVEMENT IN COUNTER + SHOW + CASES,

WITH PERPENDICULAR SLIDING DOORS. DUST PROOF.

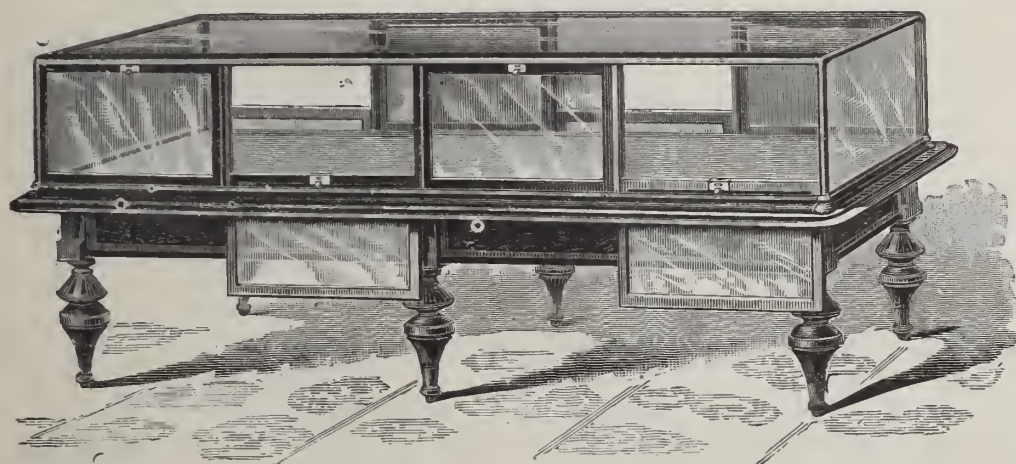

The Advantage and Convenience of these Show Cases will be apparent to everyone.

The doors are more conveniently opened and closed, less liable to get out of repair or broken, articles are more easily reached in wide cases, mirrors are more safe, it dispenses with hinges, economizes room, excludes dust, and is air tight when closed.

Drawings furnished and estimates given for fitting stores in cabinet work complete.

Letters Patent having been granted us for the construction of these doors, we shall prosecute all parties using Cases which infringe on our Patents.

B. & W. B. SMITH,

220 West 29th Street, New York.

REFERENCES:—Gorham Mfg Co., Rogers & Bro., Mitchell Vance & Co.,
Meriden Britannia Co., M. S. Smith & Co., Detroit, Mich.
D. Valentine, Syracuse, N. Y.

M. Anderson, No 57 State Street, Chicago, has the exclusive right to manufacture and sell our Improved Cases for the States of Wisconsin, Illinois, Missouri, Mississippi, Arkansas, and all States West of same.

CATALOGUE OF STYLES SENT ON APPLICATION.

STANDARD WATCH CO.



STANDARD CALENDAR

"STANDARD CALENDAR."

20 Line, Open Face, in Nickel and Silver, showing the date and day of the week, Full Jeweled, Finished Movement. The Latest Novelty offered.



"STANDARD."

18 Size, Low Price Movement, will fit Waltham and Elgin Cases.



"VESTA."

8 Size, Low Price Movement, fits Elgin Cases.



"STANDARD."

8 Size, Full Jeweled, Ladies. Fits Waltham Cases.

REGISTERED.



"STANDARD."

Nickel, 17, 19 and 20 Line. Lever, Full Jeweled.

Max Freund & Co., Sole Agents, 8 Maiden Lane, N. Y.

EXAMINE

—THE—

NEW MODEL ACME LADD CASE,

Which is universally pronounced on sight to be the Most Elegant and the Best Article in this line yet brought out.

IT HAS ALL THE LATE IMPROVEMENTS,

INCLUDING

SOLID GOLD BOWS and SOLID GOLD LININGS,

AND FOR

WORKMANSHIP, STYLE AND FINISH

IT IS UNEQUALLED.

Its Shape is such as to admit of the most elaborate ornamentation, or any intermediate style down to the plainest, without loss of effectiveness, in accordance with the taste of the purchaser.

FOR SALE BY THE LEADING WHOLESALE JOBBING TRADE.



Design No. 750.



Design No. 702.

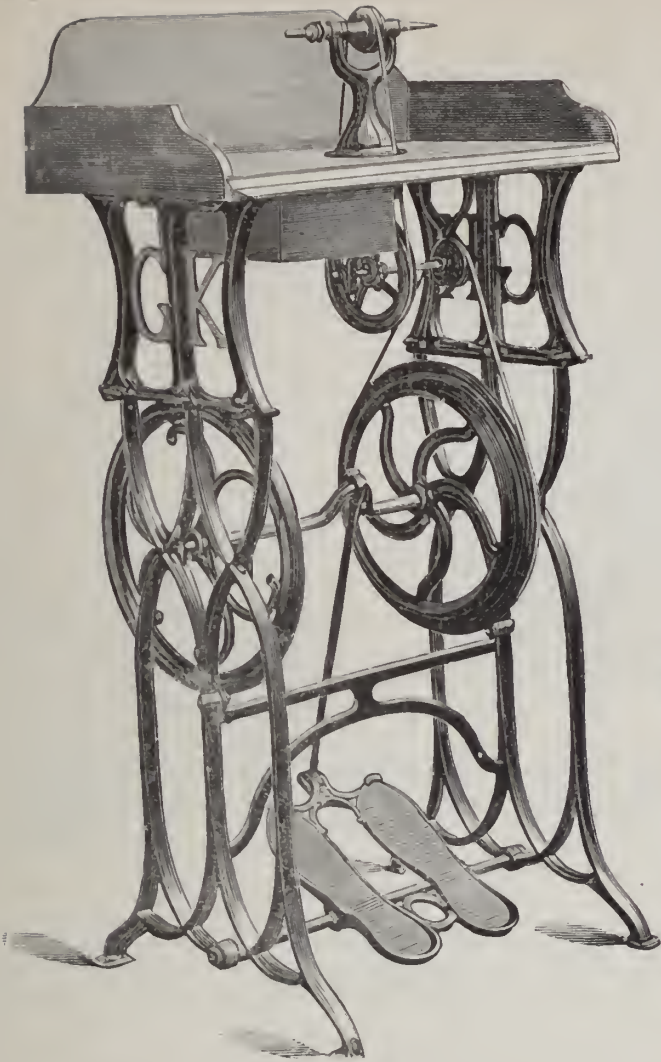

This Cut represents the Latest Design in

Watch Glass Cases.

— o —

PRICE OF CASE		
With 9 Drawers,		\$9.00
" 11 "		10.00
" 13 "		11.00



R. & L. FRIEDLANDER,

IMPORTERS OF

Watchmakers' and Jewelers' Supplies,

OPTICAL GOODS, ETC.

SOLE AGENT for the G. & K. POLISHING LATHE, Price \$10.50.

65 & 67 NASSAU STREET,

Branch, 264 Bowery

Factory, 50 Bond Street,

NEW YORK.

J. M. CHANDLER & CO.,

—MANUFACTURERS OF THE—

PATENT EMBOSSED BRACELET.

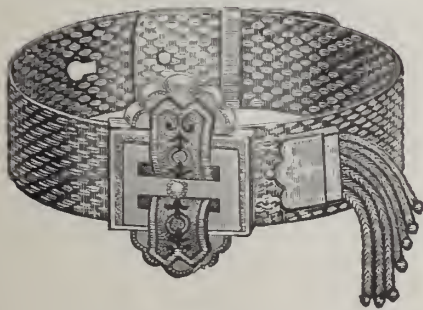

These cuts represent examples of one of the many styles of our New Patent Embossed Bracelet.



Chain Bracelets either in Gold or Plate are necessarily weak, as a small rivet is used to connect the links; when one rivet fails, the whole comes apart. The Embossed Bracelet is an exact imitation of a chain made from a solid piece of stock by a patent process, and while the goods are of the best quality, the price is much lower.

The stock from which these goods are made is plated in our factory, and we **GUARANTEE** each and every pair to wear and give satisfaction. They are adjustable and will fit any arm.

We will send Selection Packages of the Goods to Dealers on Approval.

ADDRESS ALL ORDERS TO

J. M. CHANDLER & CO.,

JOBBERS IN ALL KINDS OF

CLOCKS, WATCHES, JEWELRY, AND ALL KINDS OF TOOLS AND MATERIALS,

185 Superior Street, Cleveland, O.

☞ PARTIES INFRINGING ON OUR RIGHTS WILL BE VIGOROUSLY PROSECUTED.



GILES, BRO. & CO.

Wholesale,
Importing and
Manufacturing

→ JEWELERS, ←

101 and 103 STATE STREET,

CHICAGO, ILLS.

Complete Illustrated Catalogue Furnished the
Trade upon Application.

LANCASTER WATCH CO.

MANUFACTURERS OF

A. BETNER'S
Patent.

DUST PROOF WATCHES,

Patented
Nov. 28, 1882.

Fine Nickel and Gilt Stem-Winders.

These Watches meet a want long felt by the Trade generally. The balance being entirely closed meets the point taken by Jurgensen in his remarks upon the Resistance of the Air, as found in the CIRCULAR AND REVIEW, January No., 1883, page 414. This movement is guaranteed to be Dust-Proof, no matter in what case it may be placed. It is interchangeable with our regular case, or can be put into the Regular 18-size cases in the hands of Jewelers or Watch Dealers everywhere.

FOR SALE BY LEADING JOBBERS THROUGHOUT THE UNITED STATES.

WILLIAM H. BALL,

Successor to BALL & BARNARD,

—MANUFACTURER OF—

→ GOLD JEWELRY, ←

Roman, Enameled and Engraved Band Bracelets, with the Safety Guard Attachment. This Safety Guard is Guaranteed and costs nothing additional

ALSO A FULL LINE OF

Bangle, Braided and Padlock Bracelets.

OFFICE, 9 JOHN ST., N. Y.

SAN FRANCISCO OFFICE, 120 SUTTER ST.

FACTORY, NEWARK, N. J.

Goods Sent on Selection to Responsible Parties.

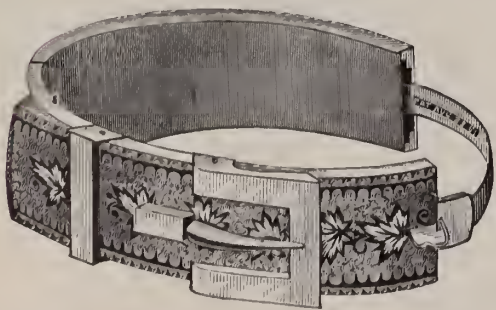

PETER B. SIMONS & CO.,

MANUFACTURERS AND IMPORTERS OF

FINE JEWELRY,

GOLD CHAIN,

Gold and Silver Thimbles, Canes, Sets, Etc.,

FOR THE TRADE ONLY.

No. 120 SUTTER STREET,
SAN FRANCISCO.

FACTORY:
611 & 613 SANSOM STREET,
PHILADELPHIA.

SALESROOM:
120 SUTTER STREET,
SAN FRANCISCO.

DEALERS IN AMERICAN AND IMPORTED

❖ GOLD ❖ AND ❖ SILVER ❖ WATCHES. ❖

PATENT CANE CASE.

Certain parties having infringed on our Patent for this most desirable Case, we now give notice that they can hereafter only be procured from us with safety.

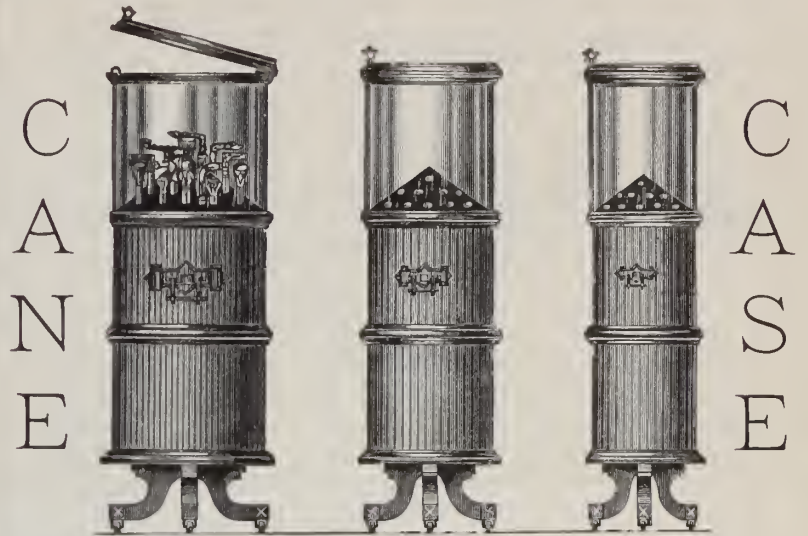

GOLD, SILVER and COPPER HEAD CANES in New Designs and Applied Work, in Greater Variety than can be found elsewhere.

SIMONS, BRO. & CO.,

611 & 613 Sansom St., PHILADELPHIA.
MANUFACTURERS OF

Cane Heads, Gold Chain, Bracelets, Thimbles and Fine Jewelry.

KEY
Patented Jan. 25,
1881.

TAG
Patented Jan. 25,
1881.

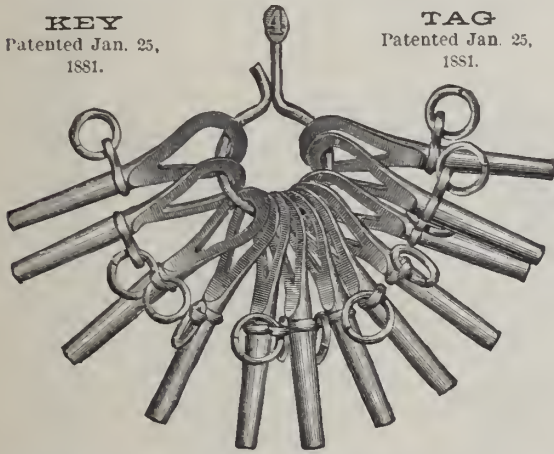

A. N. CLARK
PLAINVILLE,
CONN.,

Manufacturer of

Watch Case Springs, Watchmakers' & Jewelers' Bench Tools,
CROSBY'S JEWELING TOOLS, &c.

STOP IMPORTING KEYS!

For Low Price Key Use the

New Style Loop Key.

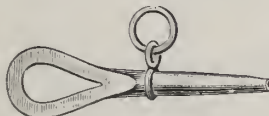

A plain Steel Key of good appearance, and excellent quality. It will not wear the pocket. It has a swivel, and is much better made than the imported plain steel or iron keys.

PRICE PER GROSS, FINE NICKEL FINISH, \$2.25
Postage, 10 Cents Per Gross Additional.

This Key is good and cheap enough to become universal. Send business card for illustrated price list. Enclose three cent stamp for sample key.

SOLD BY JOBBERS IN WATCH MATERIALS AND NOTIONS.

A. N. CLARK, Plainville, Conn.

S. C. JACKSON,
180 BROADWAY, N. Y.



IMPROVED STYLES OF
FINE CASES,
(Also a Medium Quality on Hand)
For Jewelry, Watches, Silverware, Etc.
Specialty of Fine Rosewood, &c. Trays.
Patents and Novelties from China, Japan, etc.

THE
Olin Adjustable Chuck.

CONVENIENT, DURABLE, EFFICIENT.
THE ONLY CHUCK THAT ADJUSTS THE SPLIT CHUCK.

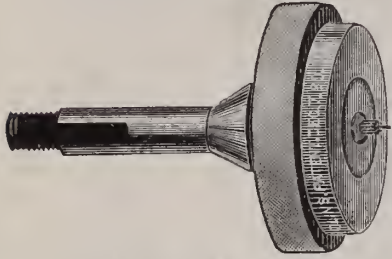

Emphatically the chuck for accurate watch-work. Made of the finest steel and nickel plated. Can be applied to any watch-makers' lathe in use. Fitted free of charge. No chuck has ever been offered to the trade that so fully meets all the requirements as the OLIN.

Every wheel, pinion or staff in a watch is easily and quickly brought to a perfect center, and held true and firm.

Every One Warranted as Represented.

PRICES.

- Chuck complete, with combination for wheel chuck, nickel plated, with Five split chucks, all in neat turned wood box, \$15.00
- Wheel chuck, put up the same way, 8.00
- Additional parts to make up complete chuck, 7.00
- Extra split chucks of any number, each, 1.00

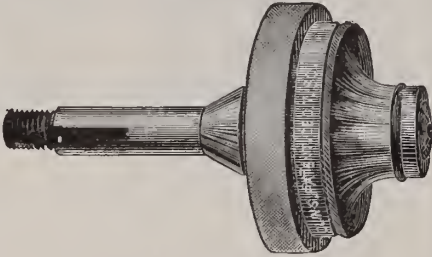

Our Split Chucks are all Tempered and Ground True.

Orders for Chucks to be fitted to American Lathes must be accompanied by a Split Chuck to fit by. If for Swiss Lathe, send the Lathe and Pulley Spindle.

Parties having Second Hand Lathes cheap, will find it to their advantage to address

THE OLIN CHUCK CO.,

MASON, MICH., U. S. A.

Birch's Patent Self-Adjusting Watch Keys.

FOR SALE BY THE TRADE GENERALLY.



2.-POCKET KEY. (Brass.)



3.-POCKET KEY. (Nickel Plated).



4.-POCKET KEY. (Nickel Plated, Hexagon Shell.)



5.-POCKET KEY. (Heavy Rolled Gold Plate Mountings.)



6.-CELLULOID MOUNTED KEY. (With Heavy Rolled Gold Plate Tips.)



35.-POCKET KEY. CELLULOID MOUNTINGS. (Imitation Malachite, with Extra Heavy Rolled Gold Plate Tips. 18. K.)



7.-BENCH KEY. (Brass Handle.)

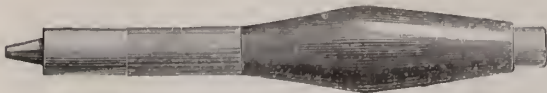

8.-SHORT WOOD HANDLE KEY. (Nickel Plated, for Bench or Pocket Use.)



9.-LONG WOOD HANDLE BENCH KEY. (Nickel Plated.)

Made in 37 Styles. Circulars on Application.

J. S. BIRCH & CO., 38 Dey Street, N. Y.

MARTINS & TISSOT,

Manufacturers of

GOLD WATCH CASES,

AND JOBBERS IN AMERICAN MOVEMENTS,

15 MAIDEN LANE, NEW YORK.

8 KARAT CASES A SPECIALTY.



Our 8 Karat Cases are of Superior

STYLE,
CONSTRUCTION
AND FINISH

to any now made, (as our constantly increasing production will attest), and are made also in large variety of styles.

LARGE STOCK
Constantly on Hand.

JOBGING TRADE SOLD ONLY.

THE

CLEANSE

R

FOR ABSORBING TARNISH
FROM GOLD, SILVER PLATED WARE, CHASED GOODS AND NICKEL.

The striking peculiarity of this "CLEANSER" is that it does its work by absorption, and does not require rubbing and labor to get the article cleansed.

It contains no Poison, Acid or Alkali (including Ammonia and Cyanide), and is warranted to give entire satisfaction or money refunded.

MANUFACTURED BY

W. M. SCOTT & CO., Philadelphia, Pa.

And for Sale by Jobbers and Manufacturers of Silverware.

Price Per Gross reduced to \$12.00; or One Dozen sent, post paid, to any address in the United States on receipt of \$1.50; or One Package 25 Cents.

Vol. XIV.

ESTABLISHED 1869.

Vol. XIV.

THE
JEWELERS' CIRCULAR
AND HOROLOGICAL REVIEW.

The XIV Volume began with the February Issue.

\$2.00 per Annum to all parts of the United States and Canada,
and all Foreign Subscriptions \$3.00.

D. H. HOPKINSON,

42 Nassau Street,

NEW YORK.

HUTCHISON & HUESTIS,

SOLID GOLD

RING MAKERS



QUALITY
GUARANTEED.

FOR
JOBBER ONLY.

No. 185 EDDY STREET,
PROVIDENCE, R. I.

New York Office, . . . 196 Broadway.

WM. M. FISHER & CO.

Sole Manufacturers of the

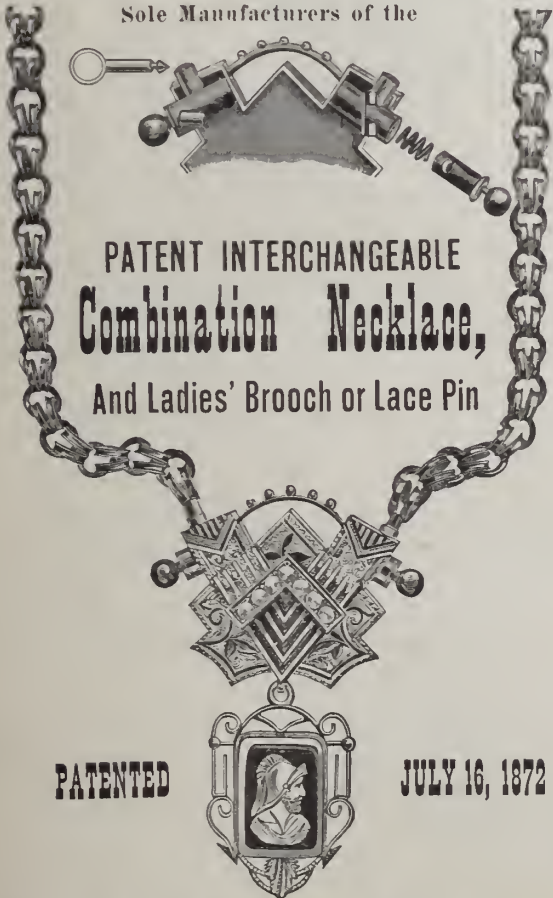

PATENT INTERCHANGEABLE
Combination Necklace,
And Ladies' Brooch or Lace Pin

GOLD
AND
SILVER
CHAINS.
Gold Chain
TRIMMINGS.

Complete
Assortment of

14-k.

Ribbon Fobs.

PATENTED

JULY 16, 1872

FOR SALE BY THE LEADING JOBBERS

The Burbank Manufacturing Company

Manufacturers of GOLD & SILVER

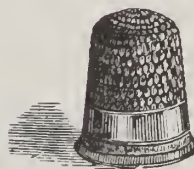

GOLD
SILVER,
STEEL,
RUBBER,
And SHELL,

Thimbles,



EYE GLASS
Self Adjusting.

SPECTACLES AND EYE-GLASSES



OF ALL DESCRIPTIONS.

SOLID GOLD RINGS

Office, 14 MAIDEN LANE. NEW YORK.

Manufactory, Springfield, Mass.

AMERICAN WATCH TOOL CO.,

WALTHAM, MASS.

MANUFACTURE THE

WHITCOMB LATHE,

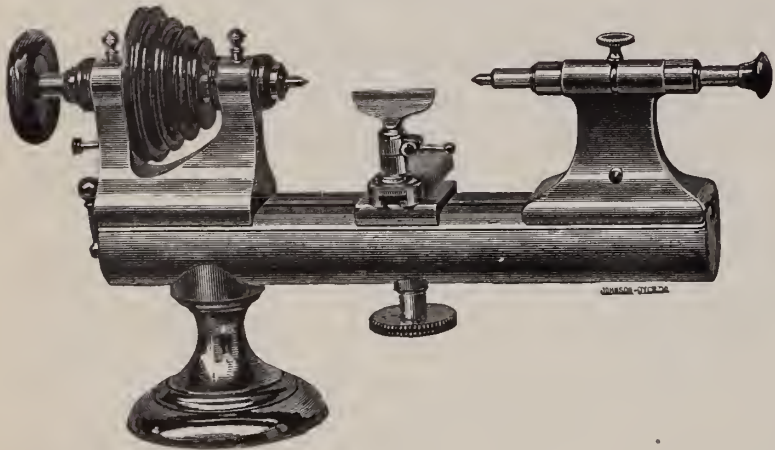

AND THE

"Webster" Foot Wheel,

We guarantee it to be a worthy companion to the Whitcomb Lathe.

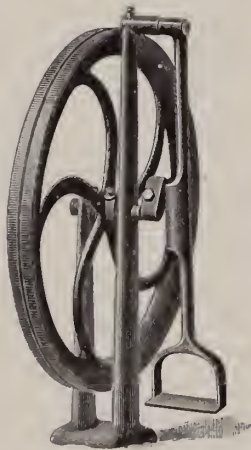

It is **not** a cheap made wheel but **First-class** in every respect.

PRICES:

30 lb. Wheel, for No. 1 Lathe, 20 inches in diameter,	\$12.00
40 " " " 1 1/2 " 20 3/4 " "	13.00
50 " " " 2 " 21 1/4 " "	14.00

DESCRIPTION.—The wheel runs on a hard steel arbor. It is clamped to the arbor by a set screw against a split bushing. This does not bend the arbor as is the case where the set screw is against the arbor. On the crank pin is a friction roll, having a hardened steel bushing, which runs on a hard steel pin. The swinging treadle is the **easiest** motion, and effects the body **less** than the foot treadle.

SEND FOR NEW CATALOGUE.

Our No. 1 1/2 Lathes are Fast Superseding all other Sizes.

Soft Lathes have Hard Mouths, Hard Wire Chucks and Hard Tail Stock Spindles.

L. W. LEVY.

E. DREYFUS.

PH. HECHT.

Levy, Dreyfus & Co.

No. 11 Maiden Lane,

P. O. Box 3567,

NEW YORK.

Optical Goods

— AND —

Watchmakers' Supplies,

Illustrated Catalogue Mailed on receipt of Business Card.



MOVEMENT DISPLAY CASE,

18 SIZE.

Each Case can be used for Key or Stem Setter.

NICKEL, (Front and Back of Glass),	PER DOZEN.	\$12.00
GILT, - - - - -		16.50

JOBBER SUPPLIED.

MONOGRAM ALBUMS,

HANDSOMELY BOUND.

2 Letters,	\$5.00
3 and 4 Letters and Full Names,	10.00
Complete 2, 3 and 4 Letters and Full Names,	15.00



Sent for Inspection on Memorandum at Purchaser's Expense.

All parts furnished separately when desired. The Springs will never rust, and are much more durable than steel.

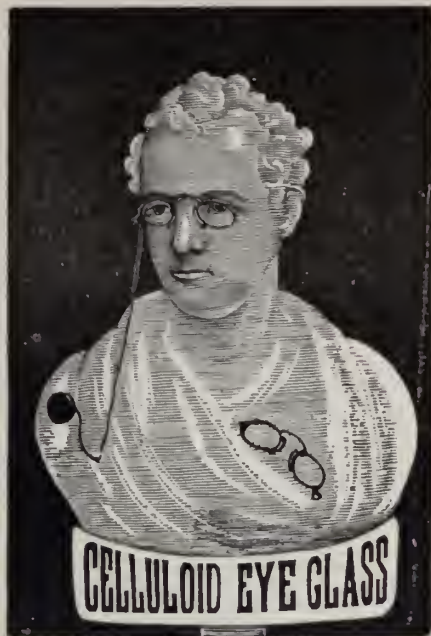

Please note a reduction of 50 cents per dozen on 286 and 288 Celluloid Eye-Glasses, No. 7 Catalogue.

The above cut represents a fine bust of Lord Byron, about twenty-five inches high, which will be furnished to parties purchasing 6 dozen Celluloid Eye-Glasses. It is securely packed, ready for shipment, and will make a very handsome ornament for the show window.

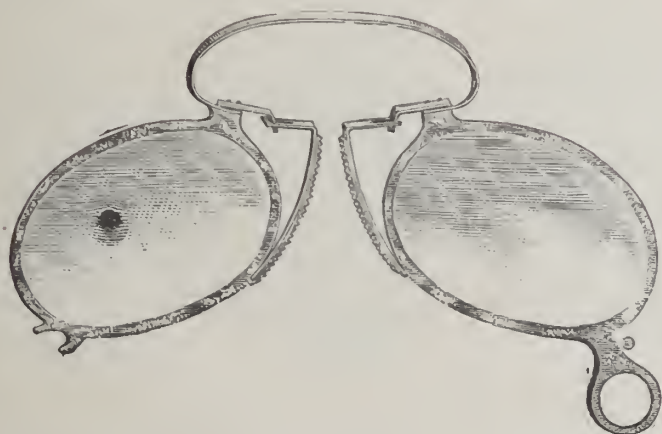

The above cut represents No. 306 Eye-Glass with an Adjustable Nose Piece, which we make in

Gold, Nickel, Celluloid, Rubber, Steel and Frameless.

This style of Eye-Glass is very popular. We make many NEW and EXCLUSIVE Styles that give a Dealer handling our goods an immense advantage over those who sell the ordinary line of goods in the market.

Special Goods, with Trade Mark, made for Dealers to Order.

Great Variety! Novel Styles! Attractive Goods!

While many houses have complained of dull trade this Spring, we have been increasing our force.

ACTIONS SPEAK PLAINER THAN WORDS.

Spencer Optical Manufacturing Co.,
13 MAIDEN LANE, NEW YORK.

Established 1853.

L. H. KELLER & CO.

Successors to G. A. HUGUENIN,

IMPORTERS OF

WATCHMAKERS' and JEWELERS'

TOOLS AND MATERIALS.

GENERAL AGENTS FOR

The Philadelphia Watch Company,

— AND —

American Watch Tool Co.,

MANUFACTURERS OF

THE WHITCOMB LATHE.

SOLE AGENTS IN THE UNITED STATES FOR THE SALE OF

LUTZ'S

**CELEBRATED ROLL HARDENED HAIR SPRINGS,
MOEBIUS OIL**

For Chronometers, Watches, Clocks, Telegraph Instruments and all other delicate machinery. Made from Pure Refined Neatsfoot Oil, and Warranted to Excel anything in the market as a Lubricator. SAMPLES GRATIS.

OUR OWN GRADUATED

AND JURGENSEN RECOILING MAINSPRINGS, pronounced by all experts Superior to all. Sold in Separate Strengths or Force.

Extra Fine Pinions cut from Solid Steel Wire. Gauged Hole Jewels of First-class Workmanship. A Full Line of Materials, for the PATEK, PHILIPPE & CO. GENEVA WATCHES, and all other Celebrated Makers.

THE BOLEY LATHES AND TOOLS,

Celebrated for their Practical, Substantial and Workmanlike Construction, Superior Design and Finish.

Our aim is to furnish nothing but First-class Serviceable Goods, especially manufactured for the Consumer, and not solely for the Market, like the cheap trash advertised in highly illustrated catalogues with which the country is flooded.

TREATISE ON MODERN HOROLOGY IN THEORY AND PRACTICE. By M. CLAUDIUS SAUNIER, Ex-Director of the School of Horology at Macon, France; Knight of the Legion of Honor, etc.; Hon. Sec. to the Paris Society of Horologists. Translated from the French by JULIEN TRIPPLIN, Besançon Watch Manufacturer, and EDWARD RIGG, M. A., Assayer in the Royal Mint, London.

This Work comprises 832 large octavo pages, with 78 wood cuts and 21 colored double-page copper-plate engravings. Bound in half calf, with an appropriate and handsome ornament in gold on front cover.

Price, \$15.00.

THE WATCHMAKER'S HAND BOOK. By the same author and translators. Intended as a companion to the Treatise. Bound in cloth.

PRICE, \$4.00.

64 Nassau Street,

NEAR MAIDEN LANE,

L. H. KELLER,
EDWARD HUNZIKER,
F. J. BOESSE.

NEW YORK.

We do not publish Price Lists.

NEW YORK OPTICAL CO.,
 Manufacturers of all kinds of
 Spectacle Lenses, Spectacles,
 Eye-Glasses
 AND
 SPECTACLE AND EYE-GLASS CASES.
 OFFICE AND SALESROOM:
 No. 43 MAIDEN LANE, N. Y.
 FACTORIES: BROOKLYN, N. Y.

BOYCE & WAINWRIGHT,
Manufacturing Jewelers
 SOLID GOLD RINGS A SPECIALTY.
 Our BAND RING Specialties for PRICE, QUALITY and FINISH are not equaled by any in the Trade.
 383 Washington St., Room 26,
 E. J. BOYCE.
 W. H. WAINWRIGHT. **Boston, Mass.**

H. WASELL,
 RUBBER STAMPS,
 BRASS STAMPS,
 Brushes, Inks, &c.
 Stencil Plates,
 Burning Brands,
 SEALS & PRESSES,
 No. 7 North William St.
 First house South of East River Bridge, N. Y.
FINE STEEL STAMPS A SPECIALTY.

H. M. RAYNOR
 No. 25 Bond St.,
 New York.
PLATINUM WIRE
 AND PLATE
 FOR JEWELERS.
 Scrap Purchased.

H. WUNDOEHL,
 GOLD & SILVER REFINER,
 Assayer and Sweep Smelter,
 21 JOHN ST.,
 Bet. Broadway & Nassau St., **NEW YORK.**
 The highest price paid for Gold, Silver and Platinum.
 Fine Gold, Silver and Copper always on hand.

JACOB STRAUSS,
WATCHES & JEWELRY
 AT WHOLESALE.
 REMOVED FROM
 18 TO; 25 JOHN STREET, N. Y.
 Rings and Rolled Plated Chains
 A SPECIALTY.

J. B. LAURENCOT,
 IMPORTER OF
 WATCH GLASSES,
Optical and Fancy Goods
 French Clocks, Musical Boxes, &c.
No. 33 MAIDEN LANE.
 5 Rue D'Enghuen, Paris.
 Box 2954, P. O. NEW YORK.

W. H. LUDEMAN,
 No. 75 & 77 Nassau Street,
 NEW YORK.
FINE AND COMPLICATED
 WATCHES
 Of every description repaired and regulated.
Stem Winding and Escape Wheels
 Cut and finished to order with accuracy and promptness.

J. J. COHN,
 IMPORTER OF
 WHITBY JET,
 MANUFACTURER OF
Gold & Rolled Plate Jewelry,
 Bracelets, Charms & Locketts a Specialty.
12 MAIDEN LANE, N. Y.
 Goods Sent on Selection if Satisfactory References are Given.

THE JEWELER'S BOAT.

OSGOOD FOLDING CANVAS BOAT
 Is the boat to buy; you can fold it up and carry it in your buggy, or on your back; it is light, safe, and strong; it rows so easily, you can't blister your hands, or unset it without considerable effort; the best portable or sportsmen's boat made in the world.
 SATISFACTION GUARANTEED. Send for Illustrated Circular, giving full particulars and references. Manufactured by
N. A. OSGOOD, Battle Creek, Mich.
 —DEALER IN—
Fine Jewelry, Diamonds & Sportsmen's Goods.

L. SAUTER.
 1 MAIDEN LANE,
 Manufacturer of
Fine and Diamond Jewelry
 AS
 Rings, Studs, Buttons, Scarf Pins, Etc.
Hair Jewelry in all its branches.
 Jobbing of every description promptly attended to.

JOHN D. LENNON,
 142 Fulton Street,
 NEW YORK,
Manufacturing Jeweler,
 Masonic Pins, Rings & Charms,
 School, Athletic, Fine
 Presentation Medals,
 —AND—
JEWELS OF EVERY DESCRIPTION
 Designs furnished free upon application.



HIBBARD G. GILL,
 GOLD AND SILVER
Watch Case Manufacturer,
 Dealer in Watches,
 American Watch Movements Always on Hand.
618 Chestnut Street,
 Fifth Floor. PHILADELPHIA.

HENRY TROEMNER,
 710 Market Street,
 PHILADELPHIA.
 Manufacturer of Fine Gold Scales,
 DIAMOND SCALES,
 Bullion Balances and
 Weights, in use at all the
 U. S. Mints and Assay
 Offices.
 PRICED CATALOGUE ON APPLICATION.

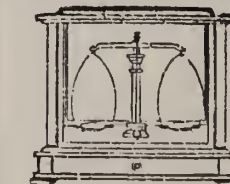

JNO. F. LUTHER,
 MANUFACTURER OF

79 Nassau Street, N. Y.
 Illustrated Catalogue sent on application.

PLATINUM

—FOR—

Scientific and Mechanical Purposes,

IMPORTED AND FOR SALE BY

The S. S. White Dental Manufacturing Co.

SCRAP PURCHASED.

PHILADELPHIA, Chestnut St., cor. Twelfth.
 NEW YORK, - 767 and 769 Broadway.
 BOSTON, - - - 160 Tremont Street.
 CHICAGO, - - 13 and 11 E. Madison St.

ADOPTED AND IN USE BY

RANDEL, BAREMORE & BILLINGS,
 58 Nassau Street, N. Y.

THE TRADE SUPPLIED.
 Descriptive Circulars Furnished
 on Application to
George W. Washburn, Patentee,
 88 Nassau St.,
 NEW YORK.

SAFETY
 EAR FASTENING, 
Pat. May 10, '81—Oct. 11, '81.

Jointed
 EAR WIRE 
 AND
 BAR BETWEEN CRAMPS
 OF SETTINGS
Patented March 1, 1881.

TELESCOPIC
 SAFETY PIN CATCH, 
Pat. Sep. 20, '81—Jan. 10, '82.

C. KNAPP,
 Manufacturer of
 Superior Band
 and Children's
STONE & FANCY
RINGS
 And Enameled Goods,
 41 Maiden Lane,
NEW YORK.



Solid Gold Rings a Specialty.

WM. H. ELY,
SOLID GOLD RINGS,
 MANUFACTURER.

Viz., Plain, Chased, Engraved, Enameled,
 Engine Turned, Shield and Scale. All
 qualities guaranteed. Orders
 Promptly Executed.
 58 Nassau Street, New York.

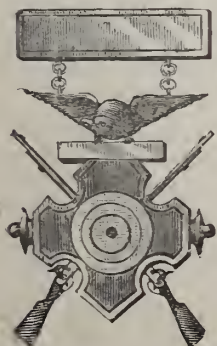

C. B. WILKINSON,
 Manufacturing Jeweler,
 8 JOHN ST., N. Y.
 Medals, Badges and
 Masonic Jewelry
A SPECIALTY.
 Designs furnished free
 upon application.

HESS & SCHLIESSER,

IMPORTERS OF

DIAMONDS

AND JEWELRY.

Specialties:—Fine Novelties in French Goods,
 Gold and Blue Enameld Locketts, Charms,
 Crosses, Garnet and Silver Filigree Goods.

25 MAIDEN LANE, NEW YORK.

WM. RAWLINGS, JR.,
 Manufacturing Jeweler,

FACTORY:

913 Arch Street, Phila.

FINE GOLD RINGS A SPECIALTY.

Goods sent on approval to any part of the
 country upon receipt of satisfactory reference.



HENRY LEFORT,
 Stem-Winding Watch Crown Manufacturer,
 Crowns and Pushers in gold, all sizes, quality and color,
 made to order. Silver crowns and pushers always on hand.
 60 Arlington Street,
 Corner William Street,
NEWARK, N. J.

We give **Special Attention** to effecting
 Settlements by **Compromise** between
 Debtor and Creditor.

COLLECTIONS.



BANKING AND COLLECTION HOUSE OF
HENRY McCABE & CO.,
 Principal Office:
 287 BROADWAY, Cor. Reade St.
 Attorneys and Correspondents at Every Point.

The Collection of Notes, Drafts, Current
 and Overdue Accounts made in all
 parts of the United States and
 Canada by our unrivaled system.

UNEXCEPTIONABLE REFERENCES AS TO
PROMPTNESS and RESPONSIBILITY.

P. JANDORF & BRO.,
Matches and Jewelry,

196 BROADWAY,

Bet. John & Fulton Sts., **NEW YORK.**

We Publish No Price Lists.

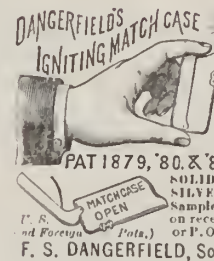

ACME OF PERFECTION!
 The Match is so universal a
 necessity, that an invention that
 can invest its use with greater
 convenience and safety is a public
 benefit. This is accomplished
 by this neat and durable article.
 The fortunate possessor has only
 to push the slide quickly, when a
 MATCH presents itself lighted.
 Your clothes need no longer be
 injured or walls defaced.
SOLID NICKEL SILVER, 50c. BONANZA
SILVER (equal to coin silver), 75c.
 Samples postpaid, to any part of the world,
 on receipt of price. 2c U. S. postage stamps
 or P. O. Order. *Sold by first-class dealers.*
F. S. DANGERFIELD, Sole Mfr., Auburn, N. Y., U. S. A.

S. KOPELOWICH & BRO.,
THE ONLY EXCLUSIVELY
Jobbing Jewelry House

Between New York and Chicago.

Jobbers of American and Swiss Watches,
 Jewelry, Silverware, Spectacles, &c.

A large assortment of which we have constantly
 on hand.

Selection packages sent to responsible parties.

Room 1, Larned Building, Syracuse, N. Y.

The **Finest Line of High-Class English**
Watches in the U. S.

GEO. E. WILKINS,
SYRACUSE, N. Y.

Agent for the Celebrated Watches of

Chas. Frodsham & Co., London,
 W. G. Schoof, London,
 Karl Zimmerman, Liverpool.

Timing and Adjusting done for the Trade.

Correspondence Solicited from the Trade.

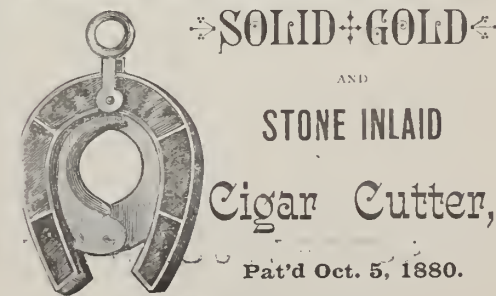

J. WIENHOLD,
 Manufacturer of **FINE JEWELRY.**
DIAMOND MOUNTINGS A SPECIALTY.

ABBOTT'S PATENT STEM WINDING DEVICES

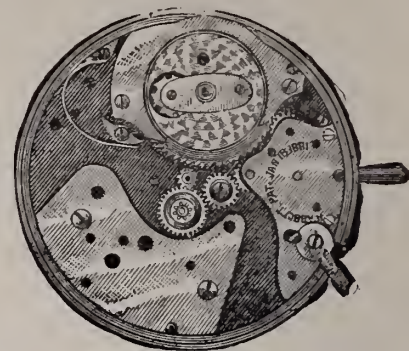
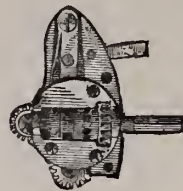
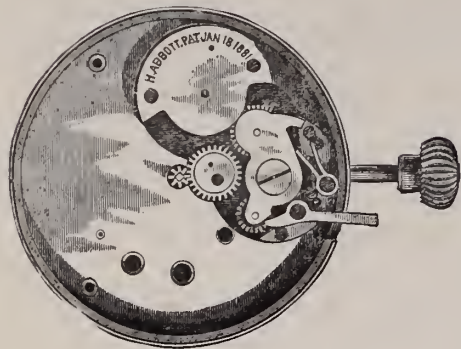

Can be applied by any Watchmaker

To 18 Size Full Plate Key Winding Watches,
made by the

American Watch Co.
Elgin Watch Co.

Illinois Watch Co.
Hampden Watch Co.

Rockford Watch Co.
Cornell Watch Co.

U. S. or Marion Watch Co.
Tremont Watch Co.

And to 16 and 18 Size Howard Watches numbered above 30,000.

The following are some of the opinions expressed, without solicitation or favor, by prominent Watchmakers and Dealers who have used them:

I have carefully examined and also used your Patent Stem Winding Attachment for American watches, and like it very much. I consider it in every respect equal to those made in the American watch factories, and in some particulars superior.

Truly yours,

Chicago, Oct. 8, 1881

W. C. POTTER.

I have used your Stem Winding Device to several American watches with great success, and always keep the devices on hand.

Respectfully,

San Antonio, Tex., May 28, 1881.

E. HERTZBERG.

I have fitted 13 of your Stem Winders during the past 10 months, and they are all giving entire satisfaction.

Respectfully,

Bay City, Mich., Oct. 22, 1881.

ED. WOOD.

I take great pleasure in saying that your Stem Winding Attachment is a decided success. I have applied it to a great many watches with satisfaction to my customers and myself.

Yours respectfully,

Middletown, N. Y., Feb. 13, 1882.

B. F. GORDON.

I altered a gold hunting watch with your Device and it works to a charm.

Cazenovia, N. Y., April 22, 1882.

W. H. CRUTTENDEN.

I have used several of your Stem Wind Attachments and they are giving the best satisfaction, working smoother than most stem wind watches I have had as they came from the factory.

Respectfully yours,

Dundee, N. Y., Feb. 14, 1883.

J. D. WIGGINS.

The gold hunting Raymond watch to which you attached your Patent Stem Winder, came duly to hand, and I cannot help but express to you my great satisfaction at the job. *I am more than pleased.*

Yours respectfully,

Easton, Pa., Jan. 18, 1883.

C. W. BIXLER.

I like your new Winding Device for Howard Watches very much.

Truly yours,

Chicago, Ill., Dec. 6, 1882.

W. C. POTTER.

We have examined the Howard Stem Wind Device and think well of it.

Yours truly,

Memphis, Tenn., Feb. 8, 1883.

C. L. BYRD & CO.

Have examined the Howard Stem Wind Device. It is certainly a most ingenious and useful piece of mechanism and ought to meet with a large sale.

Yours respectfully,

Lancaster, Pa., Feb. 5, 1883.

BOWMAN & MUSSER.

It seems to be everything that is claimed for it.

ROEHM & WRIGHT.

Detroit, Mich., Feb. 7, 1883.

We like the Howard Stem Wind Device the best of any we have yet seen.

Yours truly,

St. Paul, Minn., Feb. 15, 1883.

MYERS & FINCH.

I have examined your Device for Howard Watch and pronounce it first-class.

Yours respectfully,

Dayton, Ohio, Jan. 27, 1883.

JOHN W. TYLER.

Have examined the Stem Winding Attachment for Howard Watches and consider the same a strong and simple device, and easy to attach to watches already made. Wishing you success, we are,

Yours respectfully,

Hartford, Conn., Jan. 19, 1883.

CHAS. TESKE & CO.

Orders for these goods will be filled by Jobbers in Watches and Watch Materials, or by the Manufacturer,

HENRY ABBOTT,

FACTORY, JOHN STREET.

7 MAIDEN LANE, N. Y..

SPECIAL NOTICES.

WANTED.—An engraver who can make himself useful at the watch bench. Address Monroe, this office.

FOR SALE.—Volume 13 of the Jewelers' Circular, unbound. Price \$2.00. Apply care Jewelers' Circular, 42 Nassau St., N. Y.

TRAVELING SALESMAN acquainted in Western States will be ready for engagement July 1st. Address Chicago, care of Jewelers' Circular.

SITUATION WANTED by a watchmaker with highest recommendations. Can do first-class letter and monogram engraving. Address C. D. Fulge, care Jewelers' Circular.

SEND one, two or three dozen watches in a box at a time to have put in order, by W. F. A. Woodcock, Cumberland, Md. they will all be well done promptly and reasonably.

WATCHMAKERS and engravers wanted for a North Western city. Good opportunity and good wages paid to a first-class workman. Address W. G. Bally, Helena, Montana.

WANTED.—A competent watchmaker, and one who can do the jewelry and clock repairing. Must be temperate. Good reference required. J. E. Brierly, Birmingham, Conn.

FOR SALE.—The stock and fixtures of a jewelry store. Fresh goods and nice fixtures, valued about \$1,500. Retiring from business. Address Henry C. Jacob, Jeweler, New Haven, Conn.

WANTED.—An American Lathe, Hopkins or Whitcomb, Hopkins preferred. Also other watchmakers' tools; must be in good order and cheap. Address Lathe, Jewelers' Circular.

WANTED.—A purchaser for a jewelry store in a growing city of four thousand. Satisfactory reason given for selling out. Address G. Dix Hendricks for further information. Eaton, Ohio.

SITUATION by a young man in the jewelry business to finish his trade; has had two years' experience. Best of reference given. Address Frank S. McKee, 136 East Federal St., Youngstown, Ohio.

FOR SALE.—A nice neat jewelry store in one of the pleasantest towns in central Illinois. Will invoice about \$3,000 but can reduce stock if need be. Splendid opportunity. Address L. H. J., care Jewelers' Circular.

WANTED AT ONCE.—A situation under good instructions, by a young man of temperate habits who has had two years' experience at the bench. Best of references given. P. O. address, F. L. Suthill, Susquehanna, Pa.

MOSELEY & CO., Elgin, Ill., manufacturers of the "Moseley" Lathe, with full line of fixtures and attachments. Designed especially for the watchmaker and repairer. Combining accuracy, durability, convenience and style.

WANTED.—A first-class watchmaker who can also engrave and act as salesman in one of the best places in Kentucky. Good wages and steady employment to the right man. Address immediately, K., care Jewelers' Circular.

WANTED.—A first-class jeweler and engraver; one who can do all kinds of new work, coloring and good engraving, to go to a southern city of 50,000 inhabitants; healthy and delightful climate. Address F. & C., care Jewelers' Circular.

WANTED.—Manufacturers and importers having specialties to sell the jewelry or kindred trade, desirous of having a competent representative with an already established office in Chicago, to address H. E. S., care of Jewelers' Circular.

FOR SALE.—One-half interest in the leading jewelry store in the best town in the West. Established 11 years, business good, competition light. The best chance in the West for a man with four to five thousand capital. Loss of sight and health cause of selling. Address W. C. Burdick, Pueblo, Colo.

GEORGE E. WILKINS, manufacturer and importer of cutters for watchmakers' use, stem-winding cutters of all the different forms, rounding up cutters of the finest quality, also ratchet cutters. A large stock of second hand and new marine chronometers. No. 21 South Salina street, Syracuse, N. Y.

SITUATION WANTED by a man who understands all fine and complicated watch and French clock repairing, hard solder, jewelry jobbing and making, rings, etc. Honest and temperate, quiet and willing to work. Would take position as salesman, 10 years' experience. Address C. I. M., care Jewelers' Circular.

WATCH AND JEWELRY business for sale.—An A1 chance for a good watchmaker. Stock new and clean, will invoice about \$2,100 including fixtures; work enough for two, no competition. Growing town, junction of four railroads. Rent low, gas and steam heat in store. Address Chas. M. Hoffman, Lock Box 6, White River Junction, Vt.

ON RECEIPT of one dollar (\$1.00), I will send to any address a tool by mail, post paid, such as we used at the Elgin Watch Factory. It is invaluable to a practical or amateur watchmaker. It makes staff and pivot work easy, and is within the reach of all. Address F. P. Bishop, Prest Michigan Retail Jewelers' Association, Litchfield, Hillsdale Co., Mich.

FOR SALE.—Stock and fixtures of a jewelry store in a thriving city of 14,000 inhabitants, in Northern Illinois, not fifty miles from Chicago. Splendid chance for anyone that has got some capital. Reason for selling poor health and wishing to get into a more out-door business. Price, \$3,500. Address Diamond, care Jewelers' Circular.

NEW TOOLS.—We now have ready for the trade a set of 15 different size millers for countersinking and shaking, etc., price 40 cents each, \$5.00 per set. Also F. W. Hall's new material case, will hold 55 different kinds with each space numbered and indexed. Finished in soft wood, \$1.00 each; hard wood polished, \$1.50. Ask your jobber for them or send direct to manufacturers, J. G. Hall Mfg Co., Roxbury, Vermont.

SALESMAN WANTED.—One who has had a long and successful experience in selling solid silverware. Must be a man of fine appearance and good address. Compensation will be equal to the talent of salesman. Unquestionable references required as to capacity and character. Men of only moderate ability will please not apply. Address by letter, giving references, Theodore B. Starr, 206 Fifth Ave., N. Y. City.

WANTED IMMEDIATELY.—A first-class watchmaker, single man from thirty to forty years of age. Must be thoroughly competent, sober and industrious, and furnish the best of references. Must also have a good set of tools, and experience in repairing fine and complicated watches and chronographs, English, Swiss and American make, also a good hand at clocks. Wages \$125 a month and steady employment to competent workman; must also pay travelling expenses. Address P. Stehler, Eureka, Nevada.

BUYERS' DIRECTORY.

NEW YORK.

Assayers and Sweep Smelters.

Wundoehl, H.—Gold and Silver Refiner, Assayer and Sweep Smelter. 21 John Street, N. Y.

Badges and Medals.

Storkwell & Newman—19 John Street. Manufacturers of Badges, Medals and Presentation Pieces in Gold and Silver. Also Jewelry and Mounters of Diamonds. Designs supplied.

Wilkinson, C. B.—Manufacturing Jeweler, 8 John Street, N. Y. Medals, Badges and Masonic Jewelry a Specialty. Designs furnished free upon application.

Band Rings.

Knapp, Charles, 41 Maiden Lane, N. Y. Specialty: Superior Band Rings, also Ring Shanks & Heads for Seal and Diamond Rings.

Bangles and Bangle Rings.

Harrison, Henry—Manufacturer of Gold Bangles and Bangle Rings. Also dealer in Watches and Jewelry. 66 Nassau Street, N. Y.

Black Onyx Jewelry.

Cox & Sedgwick—Manufacturers of Black Onyx Jewelry, No. 26 John St. New York.

Lawson, Samuel—No. 18 John Street. Manufacturer of Black Onyx Jewelry. Coral repaired for the trade. Goods sent on approval to responsible dealers.

Woglom & Miller—Manufacturers of (exclusively) Black Onyx Jewelry, 32 & 34 John St., N. Y.

Blue Enameled Lockets.

Bissinger, Philip & Co.—Importers of Diamonds, Pearls and Precious Stones. Agent for the Bohemian Garnet Goods. Blue Enameled Lockets. 22 John St., N. Y.

Hess & Schliesser—Importers of Diamonds, Fine Jewelry and Novelties in French Goods. Specialties: Gold and Blue Enameled Lockets, Charms and Crosses. 25 Maiden Lane.

Bohemian Garnet Jewelry.

Bissinger, Philip & Co.—Importers of Diamonds, Pearls and Precious Stones. Sole Agent for the Bohemian Garnet Jewelry. Blue Enameled Lockets. 22 John St.

Boxes, Wood Mailing and Nested.

Maine Manufacturing Co.—Successors to Swift Mfg Co., makers of Wood Mailing and Nested Boxes for Mailing and Express purposes. J. Spencer Taylor, Agent, 18 Courtlandt St., N. Y.

Wilsbauer, J.—Manufacturer of the Sliding Cover Wood Mailing Boxes. All Sizes Made to Order. Buffalo, N. Y.

Clock Companies.

Ansonia Clock Co.—Manufacturers of every description of Clocks. 11 to 21 Cliff street, New York.

Kroeber, F.—Manufacturer and Dealer in American and French Clocks, No. 8 Cortlandt Street.

New Haven Clock Co.—62 Reade Street, N. Y.

Seth Thomas Clock Co.—20 Murray Street, N. Y.

Waterbury Clock Co.—M. Bailey, Treasurer, Manufacturers and Jobbers, No. 4 Cortland St., N. Y., and No. 197 State Street, Chicago.

Wm. L. Gilbert Clock Co.—No. 6 Murray Street, Manufacturers of Clocks. Factories, Winsted, Conn.

Corals and Coral Jewelry.

Cuppia, L. A.—Importer of Coral and Silver Filigree Jewelry, 19 Union Square, N. Y.

Cameo Cutters, Etc.

Peiter, Theodore—Cameo and Intaglio Engraver. Patentee of the Cameo-Intaglio. No. 2 Bond Street, near Broadway, Room 4 New York.

Charms & Gold Watch Keys.

Rupp & Held—Manufacturing Jewelers, Charms and Gold Watch Keys, with French and English Ratchets, a specialty. 15 John St., N. Y.

Crucibles.

Berge, J. & H.—Established 1850, Manufacturers and Importers of Sand Crucibles, Covers, Chemical Porcelain, Glassware, and Jewelers' and Assayers' Supplies, 95 John Street, N. Y.

Berge, J. & Son—Importers of Sand Crucibles and Covers, Jewelers' Tools and Materials. Manufacturers of Berge's Improved Assay and Enamel Furnace, Assay and Enamel Muffles, &c. 112 William St., N. Y.

Cutlery.

Harrison Bros. & Howson—Manufacturers of Fine Ivory and Pearl Table and Pocket Cutlery, Carvers in Cases; Nutpicks, Nutcracks and goods suitable for the jewelry trade. 126 Chambers Street. W. C. Burkinshaw, Sole Agent.

Diamond Brokers.

Anderson, Otis—Diamond Merchant and Broker, always ready to pay cash for bargains in Diamonds and Precious Stones, 4 & 6 John Street, N. Y.

Bernhardt, Richard—Diamond Broker and Importer, 65 Nassau Street (Room 6), N. Y. Paris, 20, rue des Petites-Écuries.

Friend S. & Son—Brokers and dealers in Diamonds 33 John Street, cor. Nassau St. New York.

Herbert, R. J.—Diamond Broker and Dealer. 26 Maiden Lane.

Diamond Importers.

Bissinger, Philip & Co.—Importers of Diamonds, Pearls and Precious Stones. Agent for the Bohemian Garnet Goods. Blue Enameled Lockets. No. 22 John St., N. Y.

Bruhl, D. & M.—Established 1848. Importers of Diamonds and Precious Stones. 14 Maiden Lane, New York. Branch office, Paris. Also 111 Broad Street, Providence, R. I.

Brunswick, S. & Co.—Importers of Diamonds. 17 Maiden Lane, New York. Paris, Rue Lafayette. Amsterdam, Damsstraat.

Citroen, L. B., & Co.—Diamonds. 21 John St., N. Y. Cutting Works, 57 & 61 Rapenburgerstraat, Amsterdam. House in Paris, 44 Rue Lafitte.

Engelmann, M. & Co.—Importers of Diamonds, Pearls and Precious Stones. Specialties in Fine Colored Stones. 192 Broadway and 1 and 3 John Street, N. Y. Paris, 1 Boulevard St. Denis.

Faulkenau, Oppenheimer & Co.—Manufacturers. Diamonds and Diamond Jewelry. 40 Maiden Lane, N. Y.

Fera, Henry—Importer of Diamonds, and Manufacturer of Fine Diamond Jewelry. 4 & 6 John Street, New York. Amsterdam, Holland, 23 Loojersgracht.

Fox, M. & Co.—Importers of Diamonds, Rubies, Sapphires and Fancy Gems. No. 1 Maiden Lane, New York.

Hedges, Wm. S. & Co.—Importers of Diamonds, No. 170 Broadway, corner Maiden Lane.

Kuhn, Doerflinger, & Co.—Manufacturing Jewelers and Importers of Diamonds, 18 John street, New York.

Neresheimer, E. Aug. & Co.—Importer of Diamonds. No. 21 Maiden Lane, New York.

Randel, Baremore & Billings—Importers of Diamonds, corner Maiden Lane and Nassau St.

Saunders & Ives.—Importers of Diamonds and other Precious Stones. No. 26 Maiden Lane.

Smith, Alfred H. & Co.—Importers of Diamonds, No. 182 Broadway.

Taylor & Brother.—Importers of Diamonds and Diamond Jewelry. 676 Broadway.

Wickham, D. H. & Co.—Importer of Diamonds. No. 31 Holborn Viaduct, London, 24 Maiden Lane, New York.

Wolff, G. A.—Importer of Diamonds, Rubies, Sapphires, Pearls, and other Precious Stones, 65 Maiden Lane, New York. 12 Rue de Chateaudun, Paris.

Diamond Jewelry.

Bernhard, A. & Co.—Importers of Diamonds and Manufacturers of First-Class Diamond Jewelry. Diamond Settings for Manufacturing Jewelers. Design Sheets for the Trade free of charge. 2 Maiden Lane, New York.

Bornemann, Louis.—Importer of Diamonds and Manufacturer of Rich Diamond Jewelry, 19 John Street, New York.

Chalumeau, D.—Diamond Jeweler and Manufacturer of Mountings. Novelties and Artistic Jewelry. No. 3 Maiden Lane, New York.

Hartje, G. & F.—Manufacturers of Diamond and Fine Jewelry, 860 Broadway, cor. 17th street, N. Y.

Heller & Bardel.—Manufacturers of Diamond and Pearl Jewelry, and Dealers in Diamonds, Pearls, &c. 13 John Street.

Jeanne Brothers.—Manufacturers of Diamond Mountings & Rich Jewelry. 1 Maiden Lane.

Lacroix & Verpillier.—Manufacturers of Fine Gold Jewelry. Diamonds a specialty. 173 Broadway, N. Y.

Schilling & Nissen.—Dealers in Diamonds and Diamond Jewelry. No. 51 Nassau Street, New York, near Maiden Lane.

Voelker, C. T.—Manufacturer of 18-k. Diamond Mountings, Diamond Jewelry and Roller Chain Bracelets. 189 Broadway, New York.

Waterman & Lehmann.—Manufacturing Jewelers and Dealers in Diamonds, Diamond Work, and Fine fancy Rings a specialty, any piece of single work made to order. 37 Maiden Lane, N. Y.

Diamond and Pearl Setter, &c.

Archibald, Wm.—Diamond Setter for the Trade. Cameos, Pearls, Turquoises, Garnets, Amethysts, Doublets, Foil Backs, white and colored, Imitation Stones. 73 Nassau Street, N. Y., room 7.

Diamond Cutters.

Hermann, I.—Importer of Diamonds and Precious Stones. Diamond Cutter and Polisher. Manufacturer of Diamond Jewelry. 19 East 15th Street, New York.

Levy, Herman.—Importer, Cutter and Polisher of Diamonds. 105 Fulton Street, New York.

Dials, &c.

Farnsworth, C. E. & Co.—Successors to Jno. T. Gold, Manufacturers and Jobbers in Fine Watch Dials. 81 Nassau St., N. Y.

New York Dial Co.—Manufacturers of Fine Watch Dials. Henry Abbott, Agent, No. 7 Maiden Lane, N. Y.

Enameled Clock Dials and Figures.

Caeser Bros.—Manufacturers of Enameled Clock Dials, also letters and numbers for signs. 230 and 232 East 25th Street, New York.

Enamelers, Etc.

Nutt, J. D.—Enameler on Gold, Silver, and Copper. Linen finished Buttons and Studs. Enameling in colors. 32 and 34 John Street, New York.

Orr, J. C.—Enameler on Fine Jewelry. Enameled in Colors. Linen Finished Buttons and Studs. Band Bracelets. No. 75 Nassau Street, N. Y.

Electroplaters, &c.

Jeanheure, F. & Son.—Gold and Silver Electroplaters & Fire Gilders, coloring Etruscan and Gold Jewelry a specialty. 125 Fulton St.

Engravers—Stone Seal, Etc.

Fackner, Edward.—Carver, Engraver and Chaser on Jewelry and Pencil Cases, lettering, &c., 19 John Street.

Holland & Gosling.—Stone Seal Engravers. Precious Stones inlaid and encrusted with Diamonds. No. 176 Broadway, New York, (fifth floor per elevator). Cameos cut and repaired.

Knapp, Chas.—Engraver, Die Sinker & Stamper for Jewelry purposes. Ring Shanks & superior Band rings, 41 Maiden Lane, N. Y.

Meister, H.—Engraver and Chaser on Fine Jewelry, Badges, Monograms, Coats of Arms, etc.; also Enameling, Coloring and Polishing. No. 59 Nassau Street, New York.

Park, Wm.—The Stone Seal Engraver. Arms, Crests, Monograms, etc., engraved on precious stones, 26 John Street, New York.

Weston, James F.—Stone Seal Engraver and inlaid of Precious Stones. Coats of Arms, Masonic, Odd Fellows, and other devices engraved. 32 John Street.

Fancy Goods, Clocks, Bronzes, Etc.

Le Boutillier & Co.—Importers of Fancy Goods, Clocks, Bronzes, &c., 3 Union Square.

Straus, L. & Sons.—Importers of Potteries, Faïences, Bisque Figures and Rich Fancy Goods especially adapted for the Jewelry Trade. 40, 42 and 44 Warren Street, New York.

Taylor & Bro.—Importers of French Clocks, Bronzes, etc. 676 Broadway, N. Y.

Gold and Silver Cane Heads.

Simons, Bro. & Co.—Manufacturers of Gold Headed Canes. 611 and 613 Sansom street, Philadelphia.

Gold and Silver Plating, Etc.

Battle, A.—Gold, Silver and Electro-Plating, 130 Fulton and 89 Nassau Streets, cor. Fulton Street, (Room 36,) N. Y. Watch Case Polishing.

Gold Band Bracelets.

Harrison, Henry.—Manufacturer of Gold Band and Buckle Bracelets. 66 Nassau Street, N. Y.

Gold Chains, Etc.

Beck, J. & Son.—Manufacturers of Fine Gold Chains and Chain Bracelets, 10 Liberty Place, near Maiden Lane, N. Y.

Carter, Sloan & Co.—Manufacturers of Fine Gold Chain, 15 Maiden Lane, New York.

Dorrance, Edge & Co.—Manufacturers of the Celebrated Woven Fabric Gold Chain, No. 15 John Street.

Kaufmann Bros.—Manufacturers of Gold Chains, and Chain Bracelets, 26 John Street; Factory, 331 and 333 Bowery, N. Y.

Kohn, Alois & Co.—Manufacturers of Gold Chains. 9 Maiden Lane, N. Y.

Nordt, Charles.—Successor to Nordt & Schlag, manufacturer of Gold Chains and Chain Bracelets. Jobbing and Refilling Old Chains promptly attended to. No. 17 Maiden Lane, N. Y.

Saxton, Smith & Co.—Manufacturers of Fine Gold Chain, No. 14 John Street, N. Y.

Schlag, Chas.—Late Nordt & Schlag, Manufacturer of Gold Chains, Chain Bracelets, and Fine Jewelry, 177 Broadway, N. Y.

Smith, W. & Co.—Manufacturers of Gold and Silver Chains, Jewelry, etc. No. 25 Maiden Lane, N. Y.

Gold Pens, Etc.

Aikin, Lambert & Co.—Manufacturers of Choice Gold Pens, Cases, Holders, Toothpicks, etc., 23 Maiden Lane, N. Y.

Faber, Eberhard.—Manufacturer of 16-karat Gold Pens and Pencil Cases, Nos. 718 and 720 Broadway, N. Y.

Fairchild, Leroy W.—Manufacturer of Gold Pens, Pencil Cases, Tooth Picks and Novelties in Charms. No. 18 John St., N. Y.

Johnson, E. S. & Co.—Manufacturers of Gold Pens, Pen Holders and Pencils. Cor. Maiden Lane and Nassau Street, New York.

Smith, H. M. & Co.—Manufacturers of Gold Pens and Holders, Tooth Picks, Pencils, etc. Sole Manufacturers of Sprague's Patent Gold Fountain Pen. Importers of Nickel and Silver Watches. 173 Broadway, New York.

Gold Rings.

Barnet Bros. & Powell.—Manufacturers of Stone and Seal Rings, 15 John Street, New York. Factory, Newark, N. J.

Bowden, J. B. & Co.—Manufacturing Jeweler.—Solid Gold Rings a specialty, 1 Maiden Lane.

Durlach, Henry.—Manufacturing Jeweler. No. 75 & 77 Nassau St. Seal, Cameo, Amethyst and Garnet Rings a specialty.

Ely, W. H.—Manufacturer of Solid Gold Rings of every description. No. 58 Nassau Street.

Henrich, R.—Manufacturer of Gold Rings. No. 35 Maiden Lane, N. Y.

Hildreth, H. P.—Manufacturer of Solid Gold Rings, Plain and Ornamental. No. 10 John St.

Kroll, H.—Manufacturing Jeweler. 78 Nassau Street, New York. Specialty: Solid Gold Stone Rings. All kinds of Fine Jewelry made to order, also Repairing for the Trade.

Ostby & Barton.—Manufacturers of Plain and Engraved Solid Gold Band Rings. Office, 176 Broadway, N. Y. Factory, 80 Clifford Street, Providence, R. I.

Peckham, Wm. H.—Manufacturers of Solid Gold Seamless Rings, and Fancy Embossed Rings, Patent Spectacles, Jewelry, etc. No. 4 Liberty Place N. Y.

Radler, K.—Manufacturing Jeweler. Gold Rings and Lockets a specialty. No. 39 Maiden Lane, New York.

Sauter, L.—No. 1 Maiden Lane, New York, Manufacturer of Stone Rings of every description, as Diamond, Cameo, Onyx Turquoise, etc., Scarf Pins, Scarf Rings, Studs and Buttons.

Schnurbusch, H.—Manufacturer of Solid Gold Rings. Specialty: Seal, Cameo, Pearl, Turquoise, Amethyst, Onyx and Garnet Rings. No. 104 Nassau Street, cor. Ann Street, N. Y.

Shafer & Douglass.—Manufacturers of all kinds of Seal, Stone, Turquoise, and fancy rings. No. 7 Maiden Lane, N. Y.

Sinnock & Sherrill.—Manufacturers of Stone Rings. No. 3 Maiden Lane, N. Y.

Thuerner & Church.—Manufacturers of Fine Gold Rings. No. 9 Maiden Lane, N. Y.

Hair Jewelry.

Bernhard, A. & Co.—Manufacturers of Fine Hair Jewelry. Pattern Book of 2,700 designs free of charge to the First-class Trade. 2 Maiden Lane, New York.

Moutoux, Wm. E. & Co.—Manufacturers of Fine Hair Mountings in Gold. Grand catalogues for the trade. 81 Nassau St., Rooms 1 and 2. Finest work and lowest prices

Sauter, L.—Manufacturer of Fine Gold and Hair Jewelry and Device Work. Pattern Book sent on application. No. 1 Maiden Lane, N. Y.

Schwencke O.—Manufacturer of Fine Hair Jewelry Orders from the country promptly attended to. No. 43 Maiden Lane.

Jewelry Cases, Fancy Boxes, Etc.

American Morocco Case Co.—7 and 9 Bond St., N. Y., make a specialty of Rich Jewelry and Silverware Cases for the fine Retail Trade. Also Improved Trays for Watches, Rings, etc.

Braun, Chr. E.—Manufacturer of Fine Jewelry Boxes and Trays for Show Cases and Trunks, No. 62 Chatham Street, New York. Trays for Show Cases and Trunks a Specialty.

Bricka, C. A. & Co.—Manufacturers of Morocco Cases for Cutlery, Silverware, Jewelry, etc. Sample Cards and Rolls. Cases in Rosewood, Black Walnut, etc. 52 Nassau Street, New York.

Dennison Mfg Co.—Manufacturers of Morocco, Plush and Velvet Jewelry and Silverware cases. New York, Boston, Philadelphia, Chicago, Cincinnati and St. Louis.

Ettlinger, L. & Sons.—Manufacturers of Fine Cases for Jewelry, Watches and Silverware. Trays for Travelers and Show Cases. Cases to Order a Specialty. No. 80 Nassau St., N. Y.

Haensler, Chas. C.—Manufacturer of Fine Morocco Cases for Jewelry and Silverware. Toilet Boxes, etc. Trays for Show Cases and Windows. 14 John Street, New York.

Jackson, S. C., 180 Broadway, N. Y., Manufacturer of Fine Cases for Jewelry, Silverware, &c.

Kohn, Solomon & Co.—Manufacturers of Fine Morocco Cases for Jewelry, Watches, etc. 43 Maiden Lane, New York.

Kron & Krumpel—Manufacturers of Fine Morocco and Plush Cases for Watches, Jewelry, Silverware, etc. 169 William Street, Room 11, New York. Trays for Jewelers and Sample Trays for Travelers a specialty.

Lauten, Edw. A. & Co.—No. 4 Great Jones St., Manufacturers of Fine Velvet, Brocade, Plush and Morocco Boxes, Patent Ring, Ear Ring and Gent's Scarf Pin Trays, Patent Watch and Bracelet Blocks, Window Decorations, etc.

Loehr & Koerner—Manufacturers of Morocco, Velvet, Satin, Jewelry, Watches and Silverware Cases, Jewel, Work Boxes, etc., Fancy Trays and Store Fittings to order. 96 Liberty St.

Metropolitan Fancy Box and Leather Goods Manufactory—Makers of Plush, Velvet, Satin and Leather Cases for Watches, Jewelry, Silverware, etc. 75 and 77 Nassau Street, N. Y.

New York Morocco Case Co.—Cases for Jewelry, Watches, Silverware. Boxes and Trays for Jewelers' Travelers. Show Cases and Window Fittings. No. 69 Nassau Street, New York.

Schien, Charles E.—Manufacturer of Cases for Jewelry and Silverware, No. 85 Nassau St., N. Y. Show Case Trays, etc., at short notice.

Schwarz, N.—Manufacturer of fine Cases for Jewelry and Silverware, 866 Broadway, near 17th street, N. Y.

Steinle, E.—Manufacturer of Cases for Jewelry of all kinds. Also Cases for Mathematical and Surgical Instruments and for Trays for Travelers' Trunks, etc. 66 Nassau Street, N. Y.

Welch & Miller—169 Broadway. Manufacturers of fine Morocco, Velvet, Russia, Brocade and Plush Jewelry Cases. Trays of every description; Jeweler's Cotton and Twine; Telescope Sample Cases with Flexible Trays. 169 Broadway, N. Y.

Wiggers & Froelick—No. 60 Nassau street—Manufacturers of Cases for Jewelry, &c., of every description. Trays for Show-cases, Stands for Show-windows, etc.

Jewelers' Findings.

Dennison Mfg Co.—Paper Jewelry Boxes, cards, tags, pink and white cotton, etc. etc. New York, Boston, Chicago, Cincinnati, Philadelphia, St. Louis.

Ettlinger, L. & Sons.—Manufacturers of Jewelers' Paper Boxes and Findings. Morocco Paper, Satin or Plush Lined Wooden Corner Stops Jewelry and Silverware Boxes. 80 Nassau Street, New York.

Lehmann, Ludwig.—Manufacturer of Jewelers' Findings. Tags, Pink and White Cotton, and Tissue Paper. Specialty, Fine Paper Boxes for Jewelers and Silversmiths. 122 Fulton Street.

Valfer, S. & Co.—Manufacturers and Dealers in Jewelers' Boxes, Tags, Cards, Paper and Findings. Trays a specialty. Office and Salesroom, 66 Nassau street, New York.

Jewelry Manufacturers.

Aikin, Lambert & Co.—Manufacturers General stock of Reliable Jewelry, 23 Maiden Lane.

Alford, C. G. & Co.—Manufacturers. General line fine and Reliable Goods. Specialties in Onyx Goods and Chain. 200 Broadway, New York.

Alling, Isaac A. & Co.—Manufacturers of Fine Gold Jewelry. Sets, Lace Pins, Ear Rings, Studs, Collar Buttons and Scarf Pins. Specialties: Wire Bracelets, Bangles, American Lever Sleeve Buttons. Bryant Building, Nassau and Liberty Streets, N. Y. Factory, Newark, N. J.

Baldwin, Sexton & Peterson—Makers of Fine Jewelry and Importers of Diamonds, etc., corner Broadway and Fourth Street.

Ball, W. H.—Manufacturer of Gold Jewelry. Bracelets and Bangles of all kinds a specialty. 9 John Street, N. Y.

Barthman, Straat & Co.—Manufacturers of Fine Jewelry. Roman Goods, Rings, Diamonds. No. 43 Maiden Lane.

Bernhard, A. & Co.—Manufacturers of General Fine Work. Specialties: Diamond Jewelry, Diamond Settings, Hair Jewelry, Fancy Rings, Rose Diamond Monogram and Onyx Work. 2 Maiden Lane, New York.

Brown, Thos. G. & Sons—Man'rs of Rich Jewelry Necklaces, Locketts, Bracelets, Sleeve Buttons, etc., 5 Bond Street, N. Y.

Bryant & Bentley—Manufacturing Jewelers. Rings a specialty. 12 Maiden Lane

Carter, Sloan & Co.—Manufacturing Jewelers, 15 Maiden Lane, New York.

Champenois & Co.—No. 5 Maiden Lane, manufacturers of Engraved and Enameled Gold goods, in Sets, Ear Knobs, Bracelets, Studs, Lace and Shawl Pins, Jet cluster and Onyx goods, also "Best Lever" Sleeve Buttons.

Chatellier, Joseph F.—Manufacturing Jeweler, No. 694 Broadway, N. Y.

Churchill, Lewis & Co.—Manufacturers of Fine Jewelry. 692 Broadway, cor. Fourth St., N. Y.

Cook, Groeschel & Co.—Manufacturers of Fine Jewelry and Locketts, 191 Broadway (over Mercantile Bank,) N. Y.

Cottle S. Co.—Manufacturers of Fine Jewelry. Waltham Building, 5 Bond Street, N. Y.

Cox & Sedgwick—Manufacturers of fine Onyx and Colored Jewelry. 26 John St., New York

Day & Clark—Manufacturers of Fine Jewelry, Lace Pins, Ear Rings, Studs, Locketts, &c., 192 Broadway, cor. John St., New York.

Geoffroy, Arthur R. & Co.—Manufacturing Jewelers. Novelties in Diamond Goods. No. 23 Maiden Lane, N. Y.

Goddard, John M.—Manufacturing Jeweler,—Seal Rings and Fine Locketts a specialty, No. 3 Maiden Lane, N. Y.

Goldsmith & Cohen—Manufacturing Jewelers, 3 Maiden Lane, New York.

Greason J. R. & Co.—Successors to Arthur, Rumrill & Co., 182 Broadway. Manufacturers of Fine Jewelry and Gold Chains, also Diamond Mountings.

Greene Wm. C. & Co.—Goldsmiths; Manufacturers of Rich Sets in Taper Wire Coral. Office, 192 Broadway.

Hale, S. W. & Co.—Manufacturers Rich Jewelry, Whiting Building, Broadway and 4th Street.

Hartmann, P.—Manufacturer & Importer of Fine Gold, Diamond, and Filigree Silver Jewelry, No. 36 Maiden Lane. P. O. Box 2,454.

Haskell, H. C.—Manufacturing Jeweler. Seal Rings a specialty. Special attention to Jobbing of every description. 12 John street.

Hedges, A. J. & Co.—Manufacturing Jewelers, 6 Maiden Lane.

Henderson & Winter—Jewelers, No. 15 Maiden Lane, New York. Specialties—Stone, Cameo, Onyx, Amethyst, Topaz, Pearl and Turquoise Rings.

Hunt & Owen.—Manufacturing Jewelers. Office 3 Maiden Lane.

Kennedy, Frank S.—Manufacturer and Wholesale Dealer in Jewelry and Gold and Silver Thimbles. No. 13 Maiden Lane, New York.

Kromentz & Co.—Manufacturing Jewelers, No. 182 Broadway, N. Y.

Kuhn, Doerflinger & Co.—Manufacturers of Enameled and Roman Band Bracelets, also Fine Locketts Pendants and Lace Pins. 18 John street.

Lennon, John D.—Manufacturing Jeweler, 142 Fulton Street. Stone Locketts and Rings; also Badges and Emblems of all kinds.

Miller Bros.—Manufacturers of Fine Jewelry, Locketts, Sleeve Buttons, Studs, &c., 7 Maiden Lane, N. Y.

Moore & Horton.—11 Maiden Lane, Manufacturing Jewelers, Rings, Studs, Collars and Sleeve Buttons, Pins, Ear-rings, &c.

Muhr's, H., Sons.—Manufacturing Jewelers. Solid Gold and Filled Rings a specialty. Also Manufacturers of the celebrated Crown Filled Watch Case. 1½ Maiden Lane, N. Y.

Owen, G. & S. & Co.—Manufacturing Jewelers. Office, No. 3 Maiden Lane.

Richardson, Enos & Co.—Manufacturers of Fine Gold Jewelry, Gold Chains, Locketts, Crosses and Necklaces. Colored and Etruscan Work. No. 23 Maiden Lane, New York.

Richardson, J. W. & Co.—Manufacturers of Jewelry. Masonic and other Emblems. 196 Broadway, N. Y. Manufactory, Providence, R. I.

Riley, J. A. & Co.—Manufacturing Jewelers. Etruscan Gold and Roman Bracelets, Lace Pins, Ear Rings, Scarf Pins, Brooch Pins, etc. Nos. 7 and 9 Bond Street, N. Y.

Ripley, Howland & Co.—Manufacturers of Fine Jewelry and Platinum Tipped Diamond Settings. No. 17 Maiden Lane, N. Y.

Sauter, L.—Manufacturer of Fine Jewelry, Solid Stone Rings and Studs a specialty. Jobbing for the trade. 1 Maiden Lane, New York.

Sexton & Cole—Manufacturing Jewelers, Colored Gold and Onyx Goods a specialty. No. 30 Maiden Lane.

Shafer & Douglas, Manufacturing Jewelers—Roman Goods, Lace Pins, Cameo Sets, etc., Stone Rings, etc. No. 7 Maiden Lane, N. Y.

Sheafer, W. H. & Co.—Manufacturing Jewelers, Specialty Bangles and Bracelets, 15 John St., N. Y.

Steele, J. W.—Successor to Brainerd, Steele & Co., Manufacturer of Fine Jewelry and Brainerd's Patent Locketts. No. 9 Maiden Lane, N. Y.

Stites, D. H. & Son—Manufacturers of Fine Jewelry, Rolled Plated Goods and Chains, Parisian Diamond Rings, Studs and Earrings a specialty. 41 Maiden Lane, N. Y.

Stites' Sons, E.—Manufacturers of Fine Jewelry. No. 14 John Street, N. Y.

Street, Geo. O. & Sons.—Established 1837. Makers of Fine Jewelry, strictly first-class goods of our own make. No. 15 John Street, New York.

Terhune, Charles F.—Manufacturing Jeweler, 194 Broadway, N. Y.

Thoma, Ernest—Manufacturer of Fine Jewelry, Sleeve Buttons, Rings, Ear-rings, &c. No. 173 Broadway, N. Y. Factory, Hackensack, N. J.

Ward, Thos. M.—Manufacturer of Fine Jewelry, Diamond Mountings a specialty. No. 25 John Street, N. Y.

Wheeler, Parsons & Hays.—Manufacturers of Fine Jewelry, Watch Cases, Gold Chains, &c. and Dealer in American and Swiss Watches, No. 2 Maiden Lane, N. Y.

Wienhold, Joseph—Manufacturer of Fine Jewelry Diamond Mountings a specialty. 24 John St.

Woglom & Miller—Manufacturers of Black Onyx Goods exclusively. 32 & 34 John Street, N. Y.

Jewelry—Rolled Plate.

Frick, John & Co.—Fine Rolled Plate Jewelry of all kinds. Repairing of every description. 21 and 23 Maiden Lane, N. Y.

Mauran, J. T.—Manufacturer of Fine Rolled Plate Jewelry, No. 15 Maiden Lane, N. Y.

Richards, E. Ira & Co.—Manufacturers of Fine Rolled Plate Jewelry, No. 200 Broadway, N. Y.

Weil, Leopold & Co.—Manufacturers of Rolled Plate Jewelry of every description, 35 Maiden Lane, N. Y.

Jewelers' Tools, etc.

Fisher, James J.—Dealer in Watchmakers' and Jewelers' Materials, Files, Tools, Silk Guards, Spectacles, etc., 697 Broadway, N. Y.

Frassé & Co.—Importers of Stubb' French, Swiss, German and Sheffield Tools, Files and Steel Wire for Watchmakers, Jewelers, etc., 62 Chatham street, N. Y.

Friedenthal, A. & Co.—Importers and jobbers of Watchmakers' and Jewelers' Tools, Materials, etc. 43 Maiden Lane, N. Y.

Friedlander, R. & L.—Importers of Watchmakers' Tools and Materials. 65 & 67 Nassau Street. Branch Office, 264 Bowery.

Kurtz, F. P.—Manufacturer of Jewelers Machinery, Tools, Rolling Mills, Presses, Polishing Lathes, &c. 97 Cliff St., N. Y.

Levy, Dreyfus & Co.—Importers and Jobbers of Watchmakers' and Jewelers tools and materials of every description. 11 Maiden Lane, N. Y.

Reichhelm & Koester.—Importers of Jewelers' Tools, Files, etc. Manufacturers of Brushes and Buffing wheels; also Patent Gas Furnaces for Melting, Plating, Enamelling, Annealing, etc. 80 Nassau St., N. Y.

Lapidaries.

- Fox, M. & Co.**—Practical Lapidaries, No. 1 Maiden Lane, New York.
- Graham & Co.**—Practical Lapidaries, Cutters and Polishers of all kinds of Precious Stones. Miners' Relics Cut, Polished and Mounted. Miniature, Locket and Clock Glasses. 80 Nassau St., N. Y.
- Kordmann & Michel.**—Lapidaries. Dealers in Precious Stones. Cutting and Polishing Rubies, Sapphires and other Gems a specialty. Drilling done promptly. 59 Nassau St., N. Y.

Masonic Jewelry.

- Lennon, John D.**—Manufacturer of Masonic. Odd Fellows, Athletic Clubs and other Jewelry, No. 142 Fulton Street, New York.
- Luther, John F.**—79 Nassau Street. Manufacturer of Fine Presentation Jewels for all Societies. Knights Templars, Crosses, Badges, &c.
- Popper, H.**—Manufacturer of Medals and Badges for Military, G. A. R., Shooting, Masonic, Odd Fellows, Knights of Pythias, etc. 91 Essex St., New York.

- Wilkinson, C. B.**—Manufacturing Jeweler, 8 John St., N. Y. Medals, Badges and Masonic Jewelry, a specialty. Designs furnished free upon application.

Optical Goods.

- Friedlander, R. & L.**—264 Bowery. Dealers in Optical Goods.

Opticians.

- Burbank Man'g Co.**—Manufacturers of Spectacles and Eye Glasses of all descriptions, in gold, silver, etc., 14 Maiden Lane, N. Y.
- DuBois, Geo. W. & Co.**—Importers of Watches and Optical Goods. 36 Maiden Lane, N. Y.
- Kahn, Hanover & Co.**—Importers of Spectacles, Eye-Glasses and Optical Goods generally, and Scientific Instruments of every description. 32 Maiden Lane, New York.
- Laurencott, J. B.**—Importer of Watch Glasses, Optical and Fancy Goods, Clocks, Bronzes, etc., 33 Maiden Lane, N. Y.
- Levy, Dreyfus & Co.**—Importers of Spectacles and Eye Glasses and Optical Instruments of every description, No. 11 Maiden Lane, N. Y.
- Lorsch, Albert**—Manufacturer of the Patent Accommodating Spectacles and Eye Glasses in Gold, Silver and Steel, and other Optical Goods, 37 Maiden Lane, N. Y.
- Major, W. E.**—Importer of Optical and Fancy Goods, Spectacles, Eye-Glasses, Silk Guards, Opera Glasses, Field Glasses, Telescopes, Etc. Also Dealer in Chains and Jewelers' Findings. No. 42 Maiden Lane, New York.
- New York Optical Co.**—Manufacturers of Spectacles, Eye-Glasses and Cases, No. 43 Maiden Lane, New York. (P. O. Box 2309).
- Spencer Optical Manufacturing Co.**—Gold, Silver, Steel, Nickel and Plated Spectacles; Gold, Celluloid, Steel, Nickel and Rubber Eye Glass and Opera Glasses. 13 Maiden Lane, N. Y.

Paper Boxes.

- Waterbury Paper and Box Co.**, 27 to 35 Canal St., Waterbury, Conn., Manufacture Jewelers' and Silversmiths' Fine Paper Boxes. Quality guaranteed to be equal to the best made.

Precious Stones, &c.

- Bishop, Victor & Co.**—33 Maiden Lane, Importers of Precious Stones, Cameos, &c. Also Manufacturers of Coral Jewelry.
- Bissinger, Phillip & Co.**—Importer of Diamonds, Pearls and Precious Stones. Agent for the Bohemian Garnet Goods. Blue Enamelled Locketts. No. 22 John St., N. Y.
- Breidenbach, R. A.**—Importer of Black Onyx, Cameos, Turquoise, Pearls, Sardonyx, Amethysts, Topaz, Garnets, Opals, Rubies, Sapphires, Cat's Eyes, Hematites, Brilliants, Doublets, etc. 85 Nassau St., N. Y.
- Due, Wm. & Co.**—Importer of Precious and Imitation Stones. No. 202 Broadway New York.
- Fox, M. & Co.**—Importers of Diamonds and other Precious Stones, No. 1 Maiden Lane, N. Y.
- Gruet, Jules.**—Importer of all Grades of Real and Imitation Stones. 14 John St., N. Y.

- Guntzburger Bros.**—Manufacturers and importers of Precious Stones—Amethysts, Topaz, Cameos, Garnets, Imitation Diamonds, &c. No. 9 Maiden Lane.

- Hahn & Co.**—Importers of Precious Stones. Cameos, Onyx, Pearls, Intaglios, Amethysts, Garnets, etc. 64 Nassau Street, New York.

- Kahn, L. & M.**—Importers of precious and imitation stones. 10 Maiden Lane, N. Y.

- Kipling, E. E.**—Importer of Precious and Imitation Stones. Manufacturer of the Patent Foil Solid Metal Back Rhine Stone Brilliant. No. 6 Maiden Lane, N. Y.

- Kipling, R. A.**—Precious and Imitation Stones, No. 24 Maiden Lane, N. Y. Manufacturer Cameos, Agates, Onyx, Etc., Oberstein, Germany. Commission Merchant, 49 Rue De L'Echiquier, Paris.

- Tannenbaum, L. & Co.**—Importers of Diamonds and Precious Stones. Steam Lapidary Works. Oriental Stones Cut and Polished a specialty. 65 Nassau St., N. Y.

Silverware.

- Gorham Manufacturing Co.**—Union Square.

- Knowles, J. P. & S. M.**—Manufacturers of Sterling Silverware, 20 Maiden Lane, N. Y. Factory, Providence, R. I.

- Shiebler, Geo. W.**—Manufacturer of Sterling Silverware. No. 8 Liberty Place, near Maiden Lane, N. Y.

- Whiting Manufacturing Co.**—Makers of Sterling Silver Ware. Broadway cor. 4th Street, N. Y.

- Wood & Hughes.**—Manufacturers of Fine Silverware. 16 John Street, N. Y.

Silver Filigree Jewelry.

- Cuppia, L. A.**—Manufacturer of Solid Silver Novelties, and Importer of Silver Filigree, 19 Union Square.

- Hartmann, P.**—Manufacturer of Silver Filigree Jewelry. 36 Maiden Lane, N. Y.

Silver Plated Ware.

- Holmes, Booth & Haydens**—Manufacturers of Silver-Plated Ware. 47 Chambers Street.

- Manhattan Silver Plate Co.**—Manufacturers of Silver Plated Ware. Showrooms, 23 John St. Factory, 301 to 305 East 22d St., cor. 2d Ave. Address all communications to Factory.

- Meriden Silver Plate Co.**—Manufacturers of Fine Silver Plated Ware. No. 30 E. 14th Street, New York.

- Middletown Plate Co.**—Manufacturers of Superior Electro-Plate. Factories, Middletown, Conn., salesroom, 13 John Street.

- Rogers & Bro.**—Manufacturers of the finest quality of Electro-Plated Ware. 690 Broadway.

- Rogers, Smith & Co.**—Manufacturers of Fine Electro Plated Ware. No. 46 E. 14th St., N. Y.

- Simpson, Hall, Miller & Co.**—Manufacturers of fine Silver-Plated Ware. No. 36 E. 14th Street.

- Schade, Henry.**—Manufacturer of White Metal and Plated Ware. No. 84 John St., N. Y. Price list and catalogue furnished on application.

- Webster, E. G. & Bro.**—Manufacturers of Fine Silver-Plated Ware. Office and warerooms, 14 Maiden Lane, N. Y.

Show Cases, Etc.

- Smith, B. & W. B.**—Manufacturers of Patent Improved Dust Proof Show Cases, with Perpendicular Sliding Doors, No. 220 W. 29th St., N. Y.

Spectacle Case Manufacturers.

- Bertine, P. D.**—Manufacturer of Spectacle Cases, 139 William Street, near Fulton St., New York.
- Koenen, A. & Bro.**—Manufacturers of Leather Spectacle and Eye-Glass Cases. 81 Nassau St., N. Y.

Stem Winding Attachments.

- Abbott, Henry** Maker of Stem Winding Attachments. No. 7 Maiden Lane, N. Y.

Thermometers, Etc.

- Tajlabue, Giuseppe.**—manufacturer of Thermometers, Barometers and Hydrometers. Patentee and sole manufacturer of the U. S. Standard Hydrometer. 302 Pearl Street, near Beekman.

Thimble Manufacturers.

- Barker Manuf'g Co.**—Makers of Patent Graduated Thimbles, Stiffened Gold, Filled Gold and Rolled Gold, 36 Maiden Lane, N. Y. A. Lyons, Ag't. Factory, 129 Eddy St., Providence, R. I.

- Burbank Manuf'g Co.**—Manufacturers of Gold and Silver Thimbles, 14 Maiden Lane, N. Y.

- Ketcham & McDougall.**—Improved Gold and Silver Thimbles, Bryant Building, N. Y.

- Simons Bro. & Co.**—Manufacturers of Gold and Silver Thimbles. 611 and 613 Sansom Street, Philadelphia.

- Woglom & Miller.**—Sole Agents for the "Prime" Thimbles in Gold and Silver, manufactured by Ezra C. Prime. 34 John Street, N. Y.

Watch Companies.

- American Watch Co.**—Robbins & Appleton, No. 5 Bond Street, N. Y.

- Lancaster Watch Co.**—Manufacturers of Watches. Lancaster, Pa.

- The E. Howard Watch and Clock Co.**—Cor. Maiden Lane and Nassau Street, N. Y.

- Waterbury Watch Co.**—Manufacturers of the Waterbury Watch. Factory, Waterbury. Office, 52 Maiden Lane, N. Y.

Watch and Chronometer Jeweler.

- Queen, James.**—Watch and Chronometer Jeweler and Pallet Maker, 78 Nassau Street, room 8. Pivots inserted in Pinions, Balance, Staffs, etc.

- Wennstrom, John.**—Watch, Chronometer and Clock Jeweler, Jewel Guages, Ruby and Sapphire Draw Plates; Diamonds Dressed; Polishing Stones for Jewel Settings. 2 Dutch St., N. Y.

Watch Importers, Etc.

- Abry, Chas. Leo.**—Importer and Manufacturer of Swiss Watches of all grades. 63 Nassau Street.

- Aikin, Lambert & Co.**—Importers of Watches. Sole Agents for Paul Breton & Chas. Latour, Geneva. A general line of reliable Swiss Watches, Watch Cases, etc. 23 Maiden Lane, N. Y.

- Bartens & Rice**—20 John Street, Importers of Watches and sole agents in the United States for the celebrated Nicole, Nielsen & Co. Watches.

- Cross & Beguelin.**—Importers of Watches, Watch Tools and Materials, dealers in American Watches, No. 21 Maiden Lane, N. Y.

- Droz, Henry E.**—Importer of Watches, and Watch Case Manufacturer. Agent for the "E. Perregaux" Watch, and jobber in American Watches. No. 92 Fulton Street, N. Y.

- Durfey & Reynolds**—Successors to Durfey & Shiebler, Watches, Diamonds, Jewelry. No. 9 John Street, (up-stairs) New York.

- Freund Max & Co.**—Importers of Watches, Jewelry and Precious Stones, 8 Maiden Lane, N. Y.

- Gagnebin, Chas.**—Importer of all kinds of Swiss, and Dealer in American Watches. 4 Maiden Lane, N. Y. Agent for Ulysse Breting's Fine Chronometers, Chronographs, Anchors, &c

- Gallet, Julien.**—Importer of Watches. No. 1 Maiden Lane.

- Ginnel, Henry**—Importer of Watches, Tools and Materials, 31 Maiden Lane, N. Y. P. O. Box 2967

- Heinrich, H. H. & Co.**—Sole Agents for the Karl Zimmerman Watch, and Importers of Fine Watches and Marine Chronometers. 12 John Street, N. Y.

- Herzog, Louis & Co.**—Importers of Watches, Dealers in Diamonds and Jewelry, 52 Maiden Lane, N. Y.

- Hirsch Bros.**—Dealers in Watches and Diamonds and Manufacturers of Jewelry, No. 23 Maiden Lane, N. Y.

- Hyde's Sons, John E.**—Wholesale Commission Agents, only for Jules Jurgensen, of Copenhagen; Jules Monard, of Geneva; and for other makers of all qualities of watches, 22 Maiden Lane.

- Jandorf, P. & Bro.**—Importers of Watches and Jewelry, 196 Broadway.

- Keller, L. H. & Co.**—Successors to G. A. Huguenin, Importers of Fine Watch and French Clock Materials, No. 64 Nassau Street, N. Y.

- Mathey Bros. & Mathez.**—Importers of Fine Watches and Sole Agents for the H. L. Matile's Watches. No. 16 Maiden Lane.

Oppenheimer Bros. & Veith.—Dealers in Watches and Diamonds, and Manufacturing Jewelers, No. 35 Maiden Lane.

Robert, J. Eugene.—No. 30 Maiden Lane, New York. Agent for Louis Audemar's celebrated watches.

Schwob, Adolphe.—Manufacturer and Importer of Watches, 11 Maiden Lane, N. Y.

Stern Brothers & Co..—Importers of Swiss Watches and wholesale dealers in American Watches, &c., 39 Maiden Lane.

Scott, J. T. & Co..—Importers of Watches, and Manufacturers of Jewelry, and Jobbers of all Grades of American Watches, 11 Maiden Lane.

Strasburger, Louis & Co..—Importers and Makers of Watches of every description, 15 Maiden Lane.

Watch Cases.

Dueber Watch Case Mfg Co..—Manufacturers of Gold and Silver Watch Cases. Bryant Building, N. Y. Factory, Newport, Ky.

Fahys, Joseph.—Manufacturer of Watch Cases and Dealer in American Movements, 38 Maiden Lane.

Gla'z, Chas..—Manufacturer of Silver Watch Cases. Bryant Building, cor. Nassau and Liberty Sts.

Hags'oz & Thorpe.—Manufacturers of Boss' Patent Gold and Keystone Silver Cases. 14 John Street, New York.

Keller & Untermeyer.—Manufacturers of Watch Cases with Raised Gold Ornaments. 9 Maiden Lane, N. Y.

Ladd Watch Case Co..—Manufacturers of the Ladd Patent Stiffened Gold Watch Cases, etc., 11 Maiden Lane, N. Y. Factory, 58 Eddy Street, Providence, R. I.

Willem Watch Case Co..—Makers of Gold Watch Cases. Raised Gold Ornamentation and Jurgensen style of Engine Turning. 109 Sands Street, Brooklyn, N. Y.

Watch and Chronometer Repairers.

Cerf, B..—Practical Watchmaker and Repairer, No. 10 John Street, N. Y. Repairing and adjusting of Fine Watches done for the trade. All kinds of escape and stem-winding wheels cut to order.

Heinrich, H. H. & Co..—Sole Manufacturers of H. H. Heinrich's Patent Auxiliary Balance, and Adjusters and Repairers of Fine Watches and Chronometers. 12 John Street, N. Y.

Lesperance, Theo..—Watchmaker and Wheel Cutter. Also Stoning Nickel Movements. No. 1 Maiden Lane, New York. With Julien Gallet.

Ludeman, W. H..—Chronometer and Watch Maker. Repairing of every description for the trade, 75 and 77 Nassau Street.

Watch Case Repairers.

Feinier, Joseph A..—Watch Case Maker and General Repairer. Specialty in fine Gold and Silver Cases. Jobbing promptly attended to. Nos. 4 and 6 John St., N. Y.

Tarbox, Hiram.—Watch Case Repairing, Springing, Polishing and Engine Turning. 1874 North Fourth Ave., bet. 176th and 177th Sts., N. Y.

Watch Glasses, Shades, Etc.

Brown, Edwin H..—No. 85 Nassau Street, Imported and Own Manufacture Watch Glasses, Flat, Flat Concave, Concave, Convex and fine Genevas. Fine fitting solicited.

Watches, Jewelry, etc.

Cohn, J. J..—Importer and Manufacturer of Whitby Jet, Rubber and Pearl goods. Gold and Rolled-plate Jewelry, etc. 12 Maiden Lane, New York.

Friedman, Saml..—Wholesale Dealer in Watches and Jewelry, 42 Maiden Lane, N. Y.

Fry & Schieber.—Manufacturers of Fine Gold and Plated Jewelry and Importers of Watches, 201 Broadway, N. Y.

Læberthon, L. M..—Importer of diamonds and watches. Manufacturer of jewelry. 14 John St. Fine stones a specialty.

Lissauer & Sondheim.—Wholesale Jewelers and Jobbers in American Watches, No. 12 Maiden Lane, N. Y.

Marx, Kossuth & Co..—Importers of Watches and Dealers in Jewelry. 39 Maiden Lane, N. Y.

Mayer, B..—Manufacturer of Fine Jewelry, and Dealer in Watches, 71 Nassau street, cor. John street, New York.

Mayer, Max..—Dealer in Gold and Fine Rolled Plate Jewelry of every description. 71 Nassau St., N. Y.

Myers, S. F. & Co..—Manufacturing and Wholesale Jewelers—all grades. Importers of Watches. Illustrated Catalogue to the trade. 179 Broadway, N. Y.

Smith & Knapp.—Wholesale Dealers in American and Swiss Watches, Diamonds, Gold and Plated Jewelry and Gold Chain. 182 Broadway, N. Y.

Stern & Stern.—Dealers in Watches, Jewelry and Diamonds. No. 6 Maiden Lane, N. Y.

Strauss, Jacob..—Full Line of Gold and Plated Jewelry, and Importer of Watches. 18 John Street, New York.

Thrall, E. A..—Wholesale Dealer in Watches and Jewelry. No. 1 Maiden Lane, N. Y.

Trier Bros..—Importers of Garnet, Whitley Jet and Amber Jewelry, Silk Guards, Opera, Field and Marine Glasses, Pearl Card Cases. Also a full line of Gold and Plated Jewelry. 15 Maiden Lane, N. Y.

White, N. H..—Jobber in American-Waltham Watches and Chronographs. Waltham make of 10-k., 14-k. and 18-k. Gold and Sterling Silver Cases; Filled Gold Cases. 11 Maiden Lane.

Watch Tools, etc.

Keller, L. H. & Co..—Importers of Watchmakers' and Jewelers' Tools, Materials, etc. 64 Nassau Street, N. Y.

Zimmern, Henry.—Importer of Watch Materials, Tools, and Optical Goods, No. 8 Maiden Lane, (first floor.) Sole Agent for A. Hugenin & Gravier. Mainsprings, New York.

PHILADELPHIA

Booz & Co..—Manufacturers of Gold and Silver Watch Cases and Jewelry, 108 South 8th St., Philadelphia.

Bennett, Jacob & Son.—Diamond Setters and Manufacturing Jewelers, 925 Chestnut St.

Bernard & Co..—Manufacturers of fine Roman and Etruscan Jewelry. Designs of every description made to order, 123 & 125 South Eleventh Street, Philadelphia.

Birmingham, Wm. & Co..—Morocco Case Manufacturers. Spectacle and Eye-Glass Cases a specialty, 626 Arch Street, Philadelphia, Pa.

Conover David F. & Co..—American Watches, Wholesale Salesroom, Southeast corner 7th and Chestnut Streets, Philadelphia.

Dubosq, J. Carrow.—Manufacturer of Fine Jewelry. Particular attention given to repairing Strung Pearl work. 108 South Eighth St., Phila.

Fick, Chas. M..—Seal Engraver and Designer. Sketches furnished Free of Charge for Coat of Arms, Crests, Monograms, Initial Letters and Masonic Emblems, to be engraved on all kinds of Precious Stones. 618 Chestnut St., Philadelphia, Pa.

Goldsmith, M. I..—Importer and jobber of Watch Materials, Tools, etc. 722 Chestnut St., Philadelphia, Pa.

Guilbert, Thos. M., & Co..—Manufacturing Jewelers. Flexible Bracelets and Strung Pearl Repairing. 908 Chestnut St., Philadelphia.

Hagstoz & Thorpe.—Manufacturers of Boss' Patent Gold and Keystone Silver Cases. 19th and Brown Streets, Phila. New York office, 14 John St.

Herold, Chas P..—Successor to Hildebrandt, Herold & Co., Manufacturing Jeweler and Diamond Setter. Diamonds. 916 Chestnut Street.

Krieder, Peter L..—Manufacturer of Sterling Silver Ware. 618 Chestnut Street, Philadelphia.

McCarty & Hurlburt.—Manufacturers of Gold Spectacles, Silver Thimbles and Plain Rings. Wholesale dealers in American Watches, Jewelry, etc. 131 North Second Street.

Morgan & Headly.—Manufacturing Jewelers, Cameo Sets, Gold Sets, Roman Locketts, Rings, Coral Sets and a general line of rich goods. Corner 10th and Chestnut Streets, Philadelphia.

Muhr's, H., Sons..—Manufacturing Jewelers. Solid Gold and Filled Rings a specialty. 633 and 635 Chestnut Street, Philadelphia. 1½ Maiden Lane, New York.

Peters, Reeve S..—Manufacturer of Patent Rolled Plate or Filled Watch Cases, Dealer in American Movements, 308 Chestnut Street, Philadelphia.

Robeth, A..—Wholesale Optician, and Dealer in Fine and Plated Jewelry, also Diamonds and Swiss Watches. 825 Market St., Philadelphia.

Rosenthal, G. F. C..—Manufacturing Jeweler and Diamond Setter. Engraving and Designing of Monograms a Specialty. No. 917 Sansom Street.

Scherr, L. A. & Co..—Wholesale Dealers in Watches Silver-Plated Ware, Spectacles, Fancy Goods, Watch Materials, etc. 726 Chestnut Street.

Sheafer, W. H. & Co..—Manufacturing Jewelers. Specialty: Band Bracelets. Factory, 612 and 614 Chestnut street, Philadelphia. Office, 15 John street, New York.

Simons, Brother & Co..—Manufacturers of Fine Jewelry, Cans, Thimbles, Chains. 611 and 613 Sansom Street.

Vansant, John T. & Co..—611 and 613 Sansom Street, Artisan Hall, Manufacturers and Wholesale Dealers in English Sterling Silverware. Specialties: Tea Sets, Knives, Forks, Spoons, Cups and Napkin Rings.

CHICAGO.

American Watch Company.—of Waltham, Mass. No. 170 State Street, Chicago.

Chicago Watch Case Co..—Manufacturers of Patent Dust Proof Screw Bezel Watch Cases. Cor. Madison Street and Michigan Avenue, Chicago, Ills.

Clapp & Davies.—Wholesale Jewelers, 63 and 65 Washington Street. Catalogue and price list issued to watchmakers and jewelers.

Dennison Manufacturing Co..—Manufacturers of Jewelers' Paper Boxes, Morocco Cases, Tags, Cards, Pink and White Cotton, Tissue Papers, Sealing Wax, &c., &c., 102 Madison St., Chicago. Boston, New York, St. Louis, and Philadelphia.

Excelsior Sign Co..—Manufacturers of (Grout's Excelsior) Iron Watch and Spectacle Signs. 124 Fifth Avenue, Chicago, Ills.

Gilbert Wm. L., Clock Co..—Manufacturers of Clocks, Regulators, and Time Pieces, and Clock Material of every description, 54 and 56 Madison Street, Chicago.

Giles, Bro. & Co..—Manufacturers and Jobbers in Watches, all classes of Jewelry, Materials, Clocks, Silver Ware, &c. Illustrated catalogues furnished to dealers on application. 101 & 103 State St.

Hagstoz & Thorpe.—Manufacturers of Boss' Patent Gold and Keystone Silver Cases. H. M. CARLE, Agent, Jewelers' Exchange Building.

Stein & Ellbogen.—Wholesale Dealers in Watches and Jewelry, 127 State Street, Chicago, Ill. Specialty, repairing for the trade.

Wathier, Joseph P..—Watchmakers and Jewelers for the trade, and Wholesale Dealers in Watch Materials, Tools, etc. 178 West Madison Street, Chicago, Ill. Send for price list.

Wendell, Charles & Son.—Wholesale Watches, Jewelry, etc. 170 State street, Chicago.

NEWARK.

Baker & Co..—Gold and Silver Refiners, Assayers and Sweep Smelters. 408 New Jersey Railroad Avenue, cor. Murray St., Newark, N. J.

Diefenthaler Bros. & O'Donnell.—Manufacturers of Fine Jewelry, Lace Pins, Ear Rings and Patent Spring Bangles a Specialty. 36 Crawford Street, Newark, N. J.

Felger, F. & F..—Manufacturing Jewelers. Specialties:—Roman Band Bracelets, Lace Pins, Scarf Pins, Ball and Fancy Ear Rings. No. 477 Washington Street, Newark, N. J.

Fiedler, Herrman—Successor to Kunze & Fiedler, Engraver, Die Sinker and Press Tool Maker, 363 Market Street, Opposite Pennsylvania R. R. Depot, Newark, N. J.

Hopper & Valentine—Manufacturers of Fine Jewelry, No. 8 Maple Place, Rear 44 Green St., Newark, N. J.

Huger & Heitlinger—Manufacturers to the Jobbing Trade only. Makers of Roman Stone, Engraved and Enameled Locketts, also Sets, Lace Pins and Ear Rings. Rear 477 Washington St.

Krippendorf, C. & Schuller, F.—Machinists and Jewelers' Tool Makers. 19 Greene Street, Newark, N. J. Rolls, Dies, Cutters, and Draw-plates of every Description made and repaired.

Lefort, Henry—Stem-winding Watch Crown Manufacturer. 60 Arlington Street.

Lelong, L. & Bro.—Gold and Silver Refiners Assayers and Sweep Smelters, Southwest corner of Halsey and Marshall Streets, Newark, N. J.

Miller & Beam—Manufacturers of Enameled Sets, Ear Rings, Lace Pins, etc. Guard Slides and Pendants a Specialty. 21 and 23 Green Street.

Milne, Alex.—Manufacturer of Stem-winding Watch Crowns. 19 Ward Street.

Piomb & Marcus—Manufacturers of Traveling and Marine Clocks, Electric Appliances. 289 Washington St., Newark, N. J.

Pollock, T. H.—Manufacturer of Jewelers' and Silversmiths' Wheel Brushes, Buffs, etc. No. 36 Crawford Street, Newark, N. J.

Regad, E. D.—Lapidary. Specialty—Sardonyx, Black Onyx and Agates. 14 Oliver St., Newark.

PROVIDENCE

Irons, Chas. F.—Manufacturer of Solid Gold Jewelry. Specialty, Emblems, Pins and Charms, Masonic, Odd Fellows, etc. 102 Friendship St.

Lederer, S. & B.—Manufacturers of Fire Gilt, Nickel, Electro and Silver Plated Chains, Necklaces, Charms, etc. Opera, Matinee and Guard Chains. 66 to 72 Stewart St., Providence, R. I.

Pearce & Hoagland—Manufacturers of Gold Pens, Holders, Pencils, Tooth Picks, etc. Also the Quill Reserve Tooth Pick. 29 Point Street, Providence, R. I.

Presbrey & Tuttle—Manufacturers of a large variety of Fine Bracelet and Eye-Glass Chain in Gold Plate and Silver, Spring Rings, Holders, Hooks, Snaps, etc. 35 Point St., Providence, R. I.

Seery, E. F.—Manufacturer of Fire Gilt, Nickel and Electro Plated Chains, Vest, Neck, Opera and Guard. 33 Beverly St., Providence, R. I.

Smith, Wm. T.—Assayer, Refiner and Sweep Smelter. Established 1855. Blackstone and Hawkins Streets, Providence, R. I.

Taylor, Geo. H. & Co.—Watchmakers and Wholesale Dealers in Watches, Clocks, Watch and Clock Material, Tools, Spectacles, Eye Glasses, &c. Particular attention given to trade work. 136 Westminster Street (Room 1), Providence, R. I.

PAWTUCKET.

Draper, J. O. & Co.—Manufacturers of Jewelers' Fig Soap, adapted for Washing Jewelry, Scratch Brushing and Drawing Wire. Pawtucket, R. I.

Fuller, Geo. H. & Son—Jewelers' Findings, Gold, Silver, Gold Plated and Fire Gilt. Pin Stems, Joints, Catches, Split Rings, Chain Hooks and Swivels, Ear Wires, Chain Bars, etc. 99 Exchange Street, Pawtucket, R. I.

Thayer, Ellis & Son—Brush Manufacturers, and Wholesale Dealers in all kinds of Brushes. Sole manufacturers of Ellis Thayer's Patent Polishing Wheels. Manufacturing Jewelers' and Machine Brushes a Specialty. 80 North Main Street, Pawtucket, R. I.

Thayer, P. E. & Co.—Manufacturers of Brushes, Jewelry and Machine Brushes a Specialty. All kinds of Wire Scratch Brushes on hand. Orders by mail or otherwise promptly attended to. 34 East Avenue, Pawtucket, R. I.

CINCINNATI.

Awalt, John A.—Jobber in Watches, Clocks, Jewelry, etc., 173 Vine Street, Cincinnati.

Hellebush, Clemens—Manufacturer, Importer and Wholesale Dealer in everything required by the Jewelry Trade. 77 W. Fourth St., Cincinnati, O.

Lodwick & Nolting—Wholesale Jewelers, S. W. cor. 4th & Walnut Streets, Cincinnati.

Noterman & Jonas—Manufacturing Jewelers, cor. 4th and Main Streets. Manufacturers of the Ophir Diamond Jewelry.

BALTIMORE.

Gruebel & Kesmodel—Manufacturers of Fine Diamond Etruscan, Enameled, Plain and Rhine Stone Jewelry to order. Have an assortment of Diamond Lace Pins, Rings, Ear Rings and Stud Mountings always on hand. The repairing of Fine Enameled and Etruscan Jewelry a specialty. Orders by Mail solicited. Repairing Promptly Done. 212 & 214 W. Baltimore St., Balto., Md.

Morris, Wm. & Co.—Importers and Jobbers of Watch Materials, Tools, Optical Goods, Plated and White Metal Chains. Agents for American Lathes, &c. The attention of Southern Trade is requested. 207 and 209 West Baltimore Street.

BOSTON.

Boyce & Wainwright—Manufacturers of Solid Gold Jewelry. Rings a Specialty. 383 Washington Street, Boston, Mass.

Smith, Wm. A.—Importer of Diamonds and Precious Stones. Diamonds mounted and unmounted and Diamond Mountings. 383 Washington St., Boston, Mass.

BUFFALO.

King & Eisele—Manufacturers of Solid Gold Jewelry, and Agents for American and Foreign Watches; also Jobbers in Roll Plate Jewelry. Office and Salesrooms, 283 Main St. Factory, 2, 4, 6 and 8 Swan St.

CLEVELAND.

Chandler, J. M. & Co.—Manufacturers of the Patent Embossed Bracelet and Jobbers in all kinds of Clocks, Watches, Jewelry, Tools, Materials, etc. 185 Superior St., Cleveland, O.

NORTH ATTLEBORO.

Whiting, F. M. & Co.—Manufacturers of Sterling Silver Ware and Jewelry, North Attleboro, Mass.

LANCASTER.

Bowman & Musser—Jobbers in Watches, Clocks, Chains, Fine Tools and Materials. 20 East Chestnut Street, Lancaster, Pa.

PITTSBURGH.

Goddard, Hill & Co.—Wholesale Dealers in American Watches, Jewelry, Silverware, Clocks, Materials, &c., 43 Fifth Avenue, Pittsburgh, Pa.

SPRINGFIELD.

Bullock, O. W.—Springfield, Mass. Manufacturer of Fine Nickel Plated Watch and Jeweling Tools, Keys, and Light Metallic Goods.

CANADA.

Ellis, P. W. & Co.—No. 31 King street, East Toronto, Ontario, Manufacturing Jewelers, Watchmakers, importers and Jobbers of Watchmakers, and Jewelers' Tools, Materials, General Supplies and American Jewelry. Correspondence solicited with manufacturers of Novelties or specialties in American Tools and Jewelry.

POSITIVELY NO GOODS RETAILED.

BOWMAN & MUSSER,

SUCCESSORS TO

E. F. BOWMAN,

JOBBERS IN

Watches, Clocks, Chains,

Fine Tools and Materials,

20 E. CHESTNUT STREET,

Cop. P. R. R. Passenger Depot,

LANCASTER, PA.

Selection Packages sent to Regular Jewelers on Request.

BARNES'
NO. 4 LATHE,
For the Heavier Work of Jewelers.

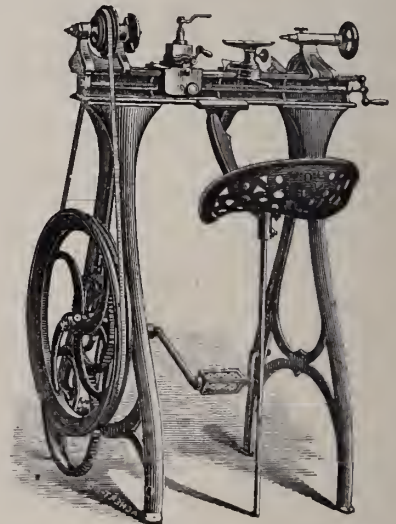

Barnes' Patent Foot and Steam Power Machinery. Complete outfits for Actual Workshop Business. Lathes for wood or metal. Circular Saws, Scroll Saws, Formers, Mortisers, Tenoners, etc., etc. Machines on trial if desired. Descriptive Catalogue and Price List Free.

W. F. & JOHN BARNES,
2088 Main Street, ROCKFORD, ILL.

EXCELSIOR'S

Practical Treatise

ON THE

BALANCE SPRING

Including Making and Fitting Hair Springs, Regulating, etc.

Also containing the Adjustment of Watches and Chronometers for Isochronism, Positions, Heat and Cold and Rate.

PRICE, \$3.50.

D. H. HOPKINSON,

42 Nassau Street, New York

ROLLED PLATE JEWELRY.

LEOPOLD WEIL & CO.

HAVE

REMOVED

TO

No. 35 MAIDEN LANE,

May 1st, 1883.

New York.

The Best Goods. Original Designs. Low Prices.

A NEW DEPARTURE.

14 Karat Gold Chain, Silver Lined,

Made by a New Process.

Guaranteed to Wear as well as the best 14 Karat Gold Chain made.

Every Chain warranted to assay *One-third* ($\frac{1}{3}$) its entire weight in 14 Karat Gold.

Every Chain stamped with registered trade mark:

“M.” “3.”

Money Refunded if Test is Unsatisfactory.

KOSSUTH MARX & CO.,

PROPRIETORS AND MANUFACTURERS,

39 Maiden Lane,

NEW YORK.

