

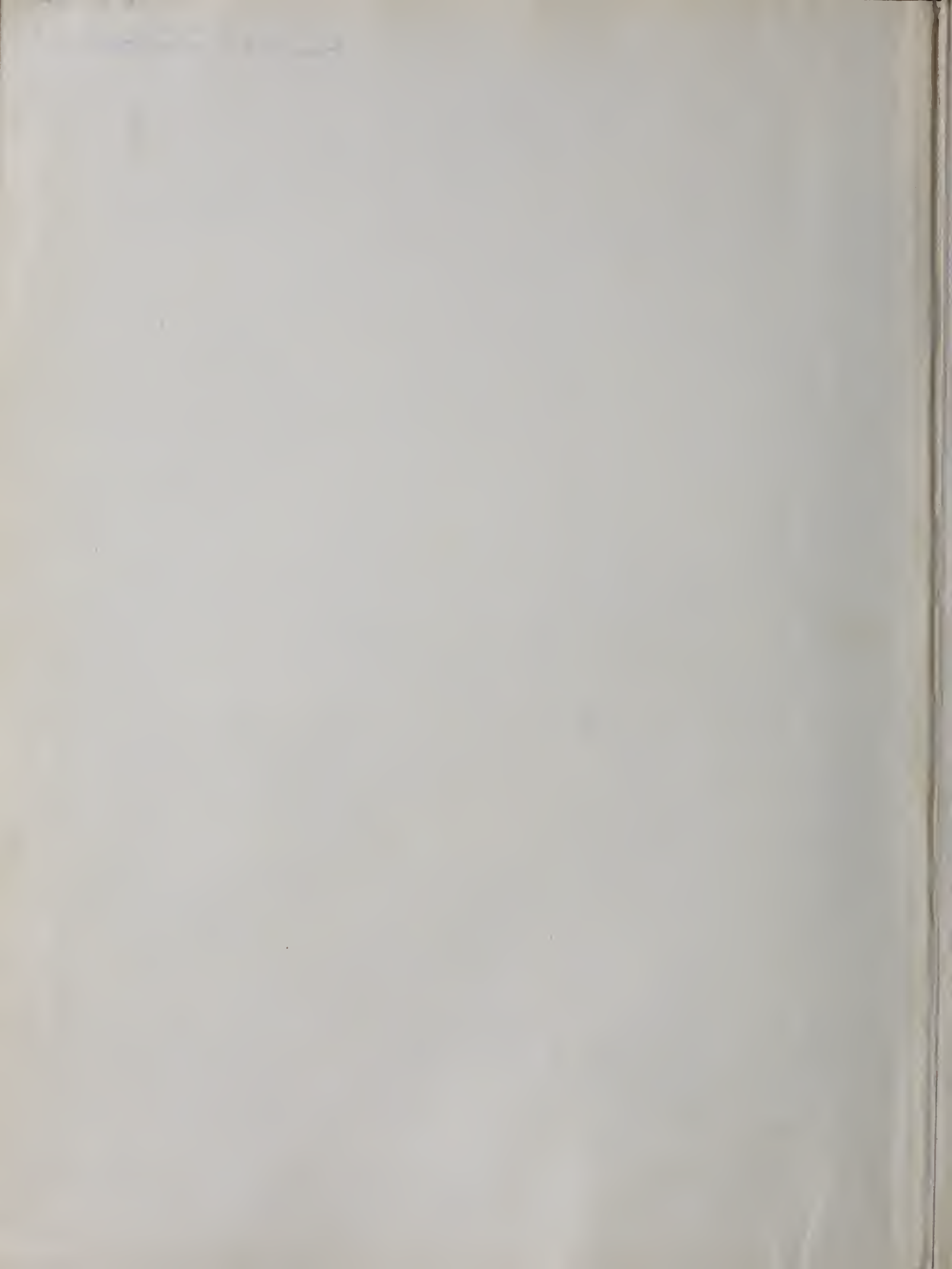



IV

1026



THE JEWELERS' CIRCULAR

WITH WHICH ARE CONSOLIDATED
THE HOROLOGICAL REVIEW,
THE JEWELERS' WEEKLY,
THE JEWELERS REVIEW

Copyright 1908 by
The Jewelers' Circular
Publishing Company.

11 John St., Corner Broadway, New York.

Entered as second-class matter at the New York, N. Y., Post Office.

40th Year.

WEDNESDAY, FEBRUARY 5, 1908.

Vol. LVI. No. 1.

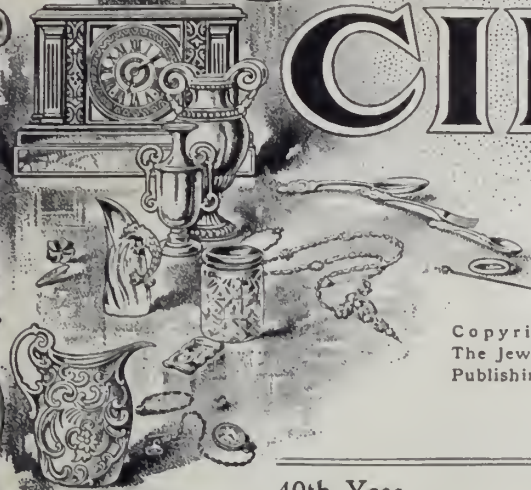

H. GRASSLER.

Modern Art Jewelry; Original Designs Drawn Expressly for the Jewelers' Circular-Weekly.
(See Text on Page 105.)

ALVIN SILVER "FLEUR-DE-LIS"
(Flower of the Lily)



ALVIN-MFG-CO
SILVERSMITHS
NEW YORK, 52 MAIDEN LANE

THE ABOVE ILLUSTRATION represents the cover of our New Catalogue showing the Fleur-de-Lis Flat Ware pattern. The catalogue illustrates the full line of ounce goods, fancy pieces and cutlery which owing, to the reduction in cost of silver bullion, are offered at reduced prices. If you have not received a copy, write us, for it.

ALVIN MFG. CO., Silversmiths, NEW YORK

Fahys

Every improvement that is known to the case maker's art is embodied in Fahys "Permanent," "Bristol" and "Montauk" Cases.

The gathering of our accumulated experience in Filled Case manufacture.



They invite comparison with all others on all points of merit.

All Fahys Cases are made with our patent one-piece pendant, which eliminates all solder.

JOSEPH FAHYS & CO.

New York

Chicago

Boston

San Francisco

A FINE LINE *of* DIAMONDS

Diamond Cutters
Private Lake

Fine Fishing
for
Retail Jewelers

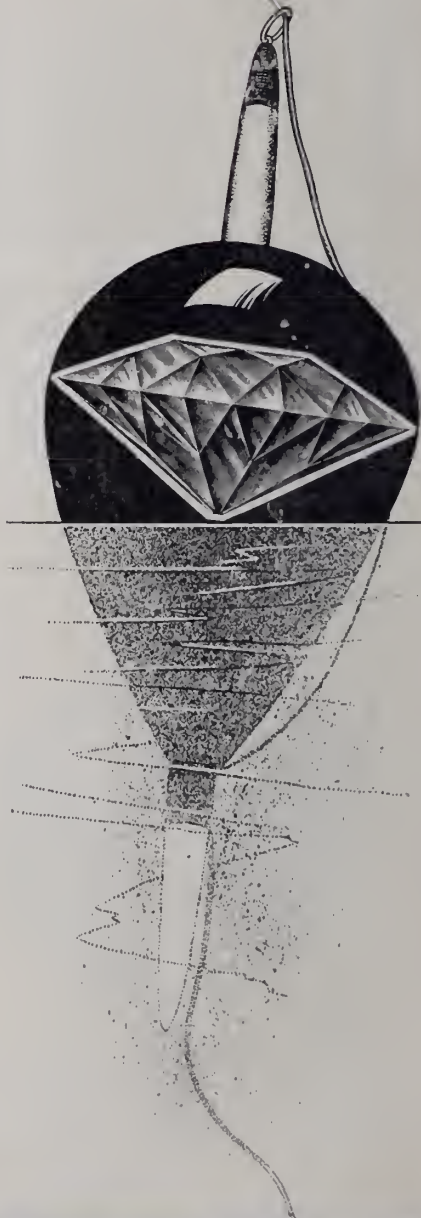
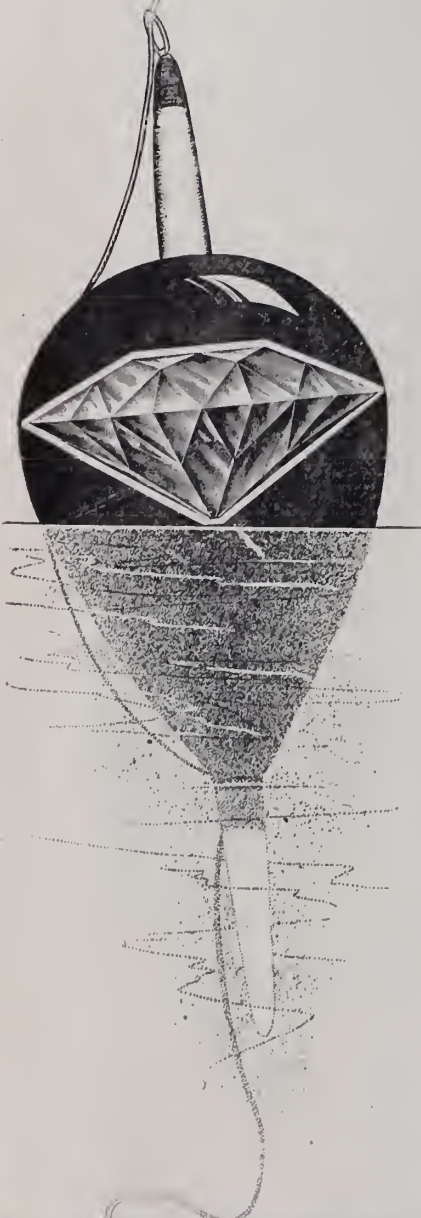

Investigation
Will Quickly
Demonstrate
That Fishing
in These
Waters
Pays Well

J.R. WOOD & SONS

The INVITATION

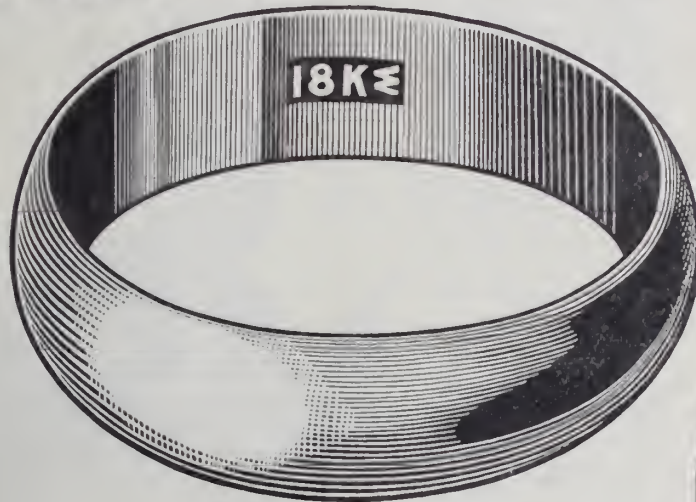

WE INVITE YOU to purchase the best wedding rings made — wedding rings of our manufacture; fully guaranteed as to plump quality and perfect finish.

With all their excellence, our prices are the lowest.

J. R. WOOD & SONS

WEDDING RING MAKERS

2 Maiden Lane, Corner of 170 Broadway
NEW YORK





NEW Goods every week. Our line contains every kind of chain and fob worn by men and women. Our new Hinge Bracelet, the Beulah, in all widths, oval and square, is pronounced the best hinge bracelet on the market. All sizes and styles are made both in side swing and hinge. Our locket fob for ladies is the proper thing.



S. O. BIGNEY & CO., ATTLEBORO MASSACHUSETTS
NEW YORK OFFICE: 3 MAIDEN LANE.

Illustration
about
four-fifths
actual size



WE have one hundred styles of Ring Mesh Bags. Our New Mesh Bag, the Elite, is a beauty, very flexible.

We are headquarters for Mesh Bags this season.

BRISTOL MANUFACTURING CO., ATTLEBORO MASSACHUSETTS

JUST THE SAME AS EVERLASTING

ALL things must yield to Father Time—nothing is indestructible.
Yet it is quite true that

WADSWORTH PERMANENT

watch cases are “just the same as everlasting,” for they will wear so much longer than anybody expects them to that, in the end, they will be carefully laid away to be cherished with the other family heirlooms.

Ghaste and artistic in design, perfect in workmanship and truly permanent, they represent the maximum of value, salability and satisfaction.

They would cost more if they were solid, but they would be no more attractive, nor would they give better service.

The Wadsworth Watch Case Co.

FACTORY
DAYTON, KY

CHICAGO
COLUMBUS BUILDING

SAN FRANCISCO
717 MARKET STREET

NEW YORK
49 MAIDEN LANE



YOU
 CAN SECURE THAT
 CLASS PIN ORDER
 BY SHOWING
 OUR DESIGNS AND SAMPLES.
 WE ARE HEADQUARTERS.
 WRITE TO EITHER FACTORY.
 WENDELL & COMPANY,
 103 AND 105 WILLIAM ST.,
 NEW YORK.
 57 WASHINGTON ST.,
 CHICAGO.

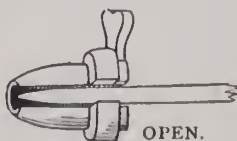

OPEN.

WENDELL'S PERFECT SAFETY CATCH

SETS CLOSE TO BODY OF PIN.
 PROTECTS POINT OF FIN TONG.
 HANDILY-LOCKED AND UNLOCKED.
 ABSOLUTELY SECURE.

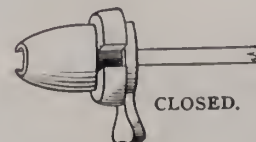

CLOSED.

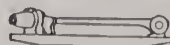



Flat Belcher ring as received with claws badly worn.



How the same ring looks when stone is reset without new claws. Stone is not secure and point is below inside of ring.

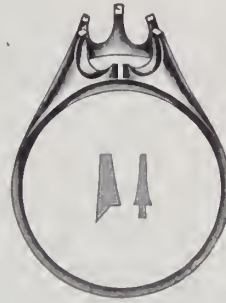

How we splice settings and solder in new claws; seams do not show and rings are as perfect as when originally made.



How ring looks with new claws and stone securely reset. Entire ring is finished like new.

When we tell you that we have received as many as 75 diamond rings in one day for new claws and settings, you will not think us extravagant for using a full page in THE JEWELERS' CIRCULAR to exploit this feature of our business, but will wonder if you are getting your share of claw work.

99 out of every 100 owners of diamond rings willingly pay \$1.50 to \$5 for new claws or settings on their rings, but would not buy new mountings for \$5 to \$25.

It is worth while to familiarize yourself and your employees with this work, as it is one of the important little things that helps to make your business profitable.

WENDELL & COMPANY

The firm that did much to change the repair end of the Retail Jewelry Business from a source of worry and dissatisfaction to one of pleasure and profit.

103-105 William Street
New York

TWO WONDERFUL SHOPS

57 Washington Street
Chicago



Tiffany ring as received with worn off claws. Stone cannot be reset, as it would be too low to look well and the point would come below the inner circle of ring.
(See cut No. 2 of flat belcher.)

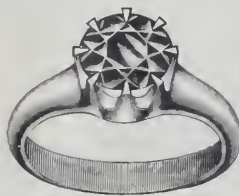

How same ring looks with new claws and stone securely reset. Entire ring is finished like new.

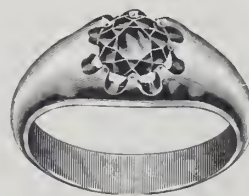

Oval Belcher ring as received with claws badly worn. Stone cannot be reset, as it would be too low to look well and the point would come below the inner circle of ring.
(See cut No. 2 of flat belcher.)

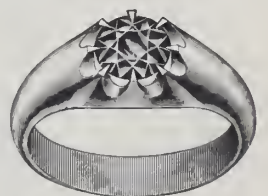

How same ring looks with new claws and stone securely reset. Entire ring is finished like new.

THE PRICES QUOTED ABOVE FOR NEW CLAWS AND SETTINGS ARE SUBJECT TO OUR CATALOGUE DISCOUNT.

WE CAN PUT NEW CLAWS AND SETTINGS ON MOUNTINGS TAKEN IN TRADE AND REFINISH THEM SO THEY WILL BE AS GOOD AS NEW.

WE RETIP CLAWS AND MAKE NEW SETTINGS FOR CLUSTER MOUNTINGS SO THEY ARE AS GOOD AS WHEN ORIGINALLY MADE, AT PRICES THAT MAKE IT ADVANTAGEOUS FOR THE OWNERS TO HAVE THIS WORK DONE.

Carrying no diamonds in stock, entering and tagging each piece of diamond jewelry as received, then giving to each workman but one ring at a time, which is returned before he receives another, prevent any possibility of diamonds being exchanged while in our possession.

Late
 Attractive
 Designs
 (25 YR. 14 K.)



The
 Four Hundred
 Series

THE Dueber-Hampden
 Watch Mfg. Co.
 CANTON OHIO.

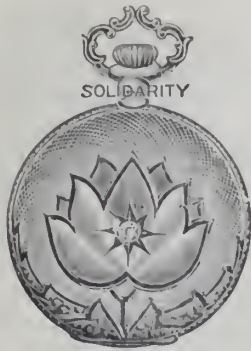

MARGUERITE

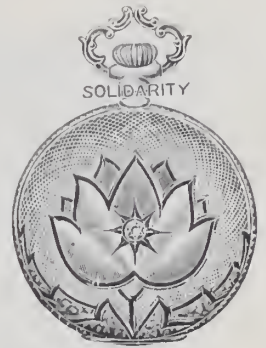

MARGUERITE

Mr. Retailer :

CERTAINLY we are forging ahead. So long as boys grow to be men, and girls to be women, so long will WATCHES be a NECESSARY luxury.

Millions of watches will be sold in 1908

and

SOLIDARITY GOLD WATCH CASES will be one of the most important factors in determining the LUXURY of these necessities.

Your jobber will supply them.

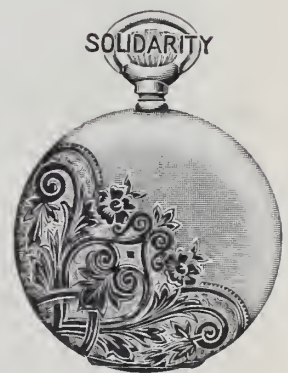

Solidarity Watch Case Company

Established 1885

54 Maiden Lane, New York

General Selling Agents :

JOHN W. SHERWOOD

:::::

FRANK E. HARMER

The Big Dipper

Will Dip Up Profits For You



THE
BEST IN EVERY
GRADE

CHICAGO
701 Heyworth Bldg.

Ask your Jobber

NEW YORK
Maiden Lane

STARWATCH CASE CO.

LUDINGTON, MICHIGAN

COPYRIGHTED BY T. F. KENNEDY

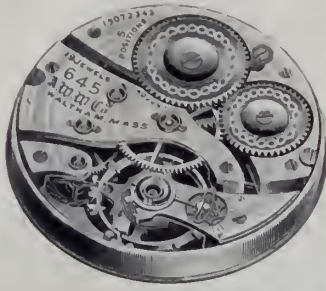

CROSS and BEGUELIN

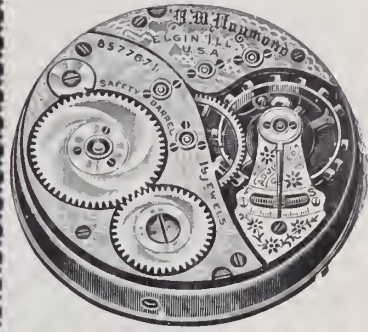

We Carry All Grades of
**RAILROAD
MOVEMENTS**

Send us your orders for ANY
goods you may wish, as we
carry all kinds of goods used
by first-class Jewelers, either
in the Watch, Diamond, Gold
and Plated Jewelry Line.
Watch Materials, etc., etc.

**31 MAIDEN LANE,
NEW YORK**



ESTABLISHED 1863

TELEPHONE 480 JOHN



The Smartest New Effects in Gold Mounted Combs

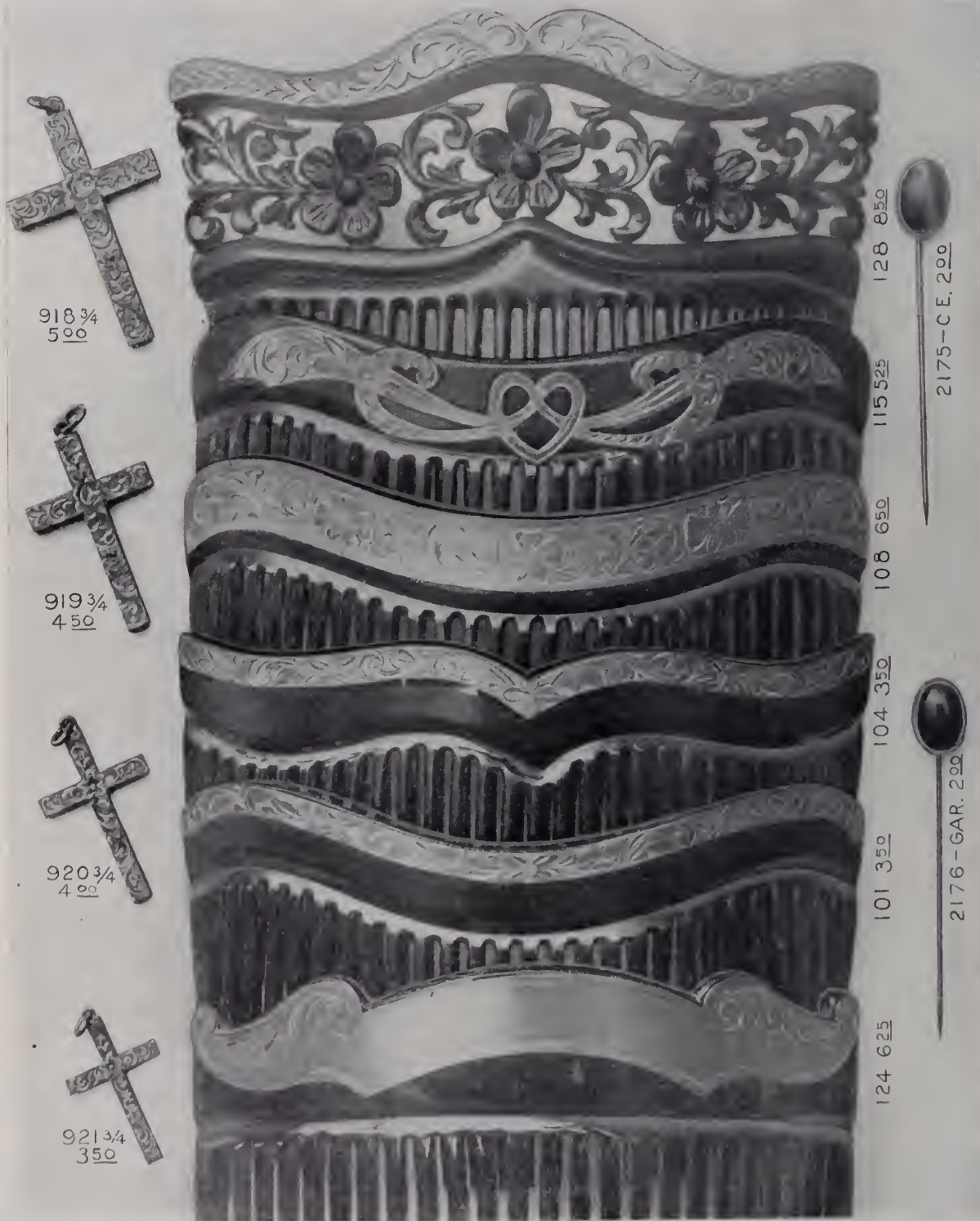

The above is a Specimen Page from our New Spring Catalogue. Send for a copy.

The New Spring Catalogue of the

The Keller Jewelry Mfg. Co.
64 Nassau Street, New York

Showing the Newest Designs in 10K. Jewelry

The Newest Creations in Brooches for 1908 Our Line is Absolutely Plump 10 Karat



The above are retail prices ; write for our prices to you. Illustrations from a sheet of our New Spring Catalogue

LINK BUTTONS COMBS TIE CLASPS FOBS NECK CHAINS
BROOCHES SCARF PINS LOCKETS CHARMS LORNETTE CHAINS

Factory
8 Lum Street
Newark, N. J.

The Keller Jewelry Mfg. Co.
64 Nassau Street, New York

Manufacturers
of
Fine Gold Jewelry



Mercantile Self-filling Fountain Pen

affords the most practical, well-made and high grade pen on the market. The ingenuity displayed in the preparation and production of the Mercantile Self-filler is immediately apparent, and, coupled with all the other points of perfection, the self-filling feature is most timely. The simplicity of construction allows the pen to be emptied, cleaned or filled by merely a pressure of the finger, and all possibility of accidental discharge is eliminated.

THE CONSTRUCTION is the best that scientific mechanics can produce.

THE GOLD PEN is 14Kt. fine, tipped with selected hard iridium, and made in points fine, medium, coarse and stub.

THE BARREL which is of regular size, contains the rubber sack which retains the ink. The sack is conveniently secreted, although readily exposed for filling by a simple twist of the barrel slide.

THE BARREL SLIDE does not interfere in the least with the contour of the pen.

THE FEED is perfect; the ink flowing only as required, down to the very last drop in the retainer.

MADE IN ALL SIZES. THE PRICES ARE LOW AND THE DISCOUNTS LIBERAL.

BEACON STYLOGRAPHIC PEN

The only perfect, easy-writing "ink pencil." For many years one of our leading lines, the demand for which you have undoubtedly felt growing continually, they having taken a very great stride in popularity during the past few months, due to the attainment of perfection of manufacture after many years of continual improvements. The great advantage of the Beacon over all other makes is the adjustable Spring Needle. It is arranged on silver yoke and gold spring; it is very simple and easily adjusted, producing a perfect writer, long life and cleanliness.

**THEY NEED
ONLY TO BE
DISPLAYED TO SELL**

THE REASON:

Neat, graceful and well-made. Due to the vibrating needle, the "pencil" is always ready, is self-cleaning, and will not get out of order. When finished writing, lay it down or place it in the pocket in any position, and it will never leak.



Made in all styles and sizes, from \$1.00 up.
Write for complete catalogue and information.

Aikin-Lambert Co.

ESTABLISHED 1864

33 Maiden Lane, New York

¶ This is the age of specialties.

¶ Believing this to be true we have equipped a special department with the most modern appliances and engaged the most skillful artisans, the better to enable us to serve the jewelry trade.



H. F. GRUSCHOW
Manager, Jewelry Catalog
Department

¶ Our Jewelry Catalog Department is directed by Mr. H. F. Gruschow, who has had a practical experience in the jewelry business for many years.

¶ We handle jewelry, silverware, etc., as it should be handled. Not as an ordinary piece of merchandise.

¶ The goods will be returned as clean and neat as when received by us. You jewelry men will appreciate this advantage.

¶ If you have anything on your mind let us have it. We solicit correspondence.

¶ See reverse side of this page.

PENINSULAR ENGRAVING COMPANY

DE CROIT

MICHIGAN

Three-Color Direct Process Work

See other side of this plate



Manufactured by
Hess & Sons, Inc. 3-3-35
Boston, U.S.A.

Manufactured by
Hess & Sons, Inc. 3-3-35

Manufactured by
Hess & Sons, Inc. 3-3-35
Boston, U.S.A.

Whiting Flatware



As recently here announced, the Whiting Company have made very material reductions in the prices of their entire line of flatware due to the decline in the cost of bullion.

But it is not only by its prices that the Whiting flatware appeals to the judicious buyer of silverware. Its marked individuality of design and superiority of workmanship are qualities which have gained for it the acknowledged position it holds in the estimation of the public.

In replenishing his stock of WHITING flatware therefore, the Retail Jeweler, will be, in effect, catering to his most discerning customers.

WHITING MFG. COMPANY

Silversmiths

Broadway and Nineteenth Street

New York

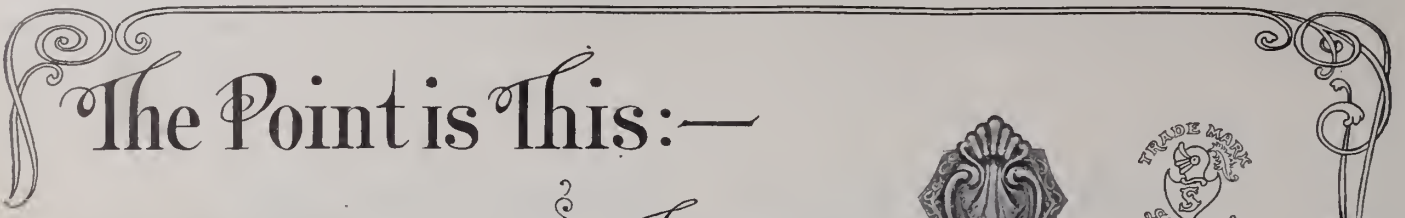

The Point is This:—

The name
Duchesse

signifies delicacy
combined with
durability;
the qualities found
in Old Point Lace
of that name
which we adopt
for our
new pattern in
Sterling
Silver
Flatware

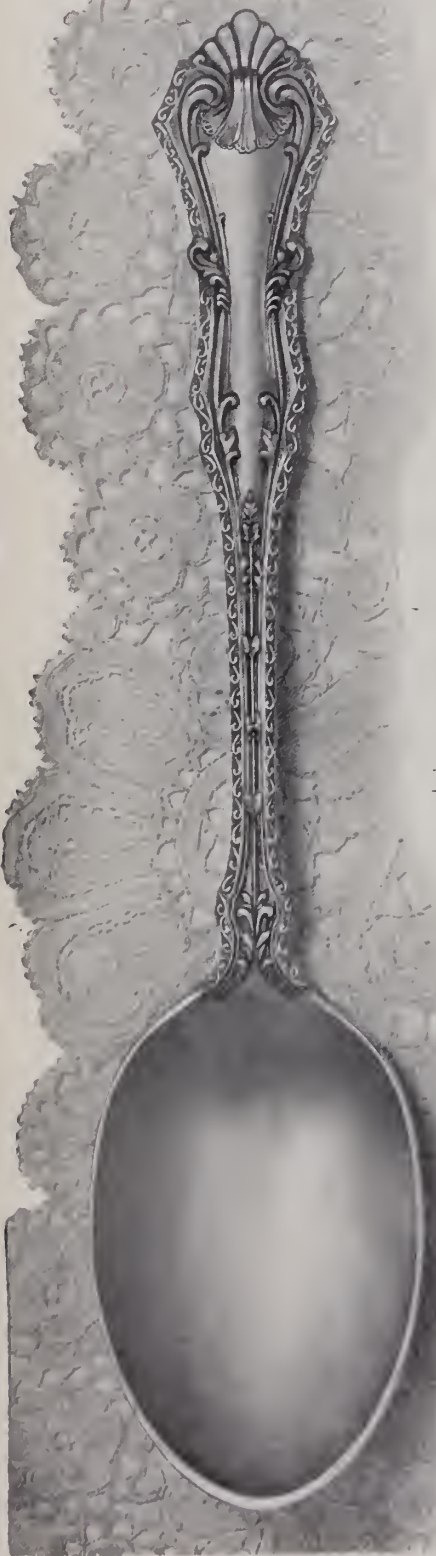

TABLE SPOON



SUGAR SHELL



MEDIUM FORK

Furnished in
Bright or French Gray
DESIGN PATENTED

MADE BY

Simpson, Hall, Miller & Co.
International Silver Co., Successor
Wallingford, Conn., U.S.A.

NEW YORK SAN FRANCISCO
CHICAGO • TORONTO

SILVERSMITHS *to the* **AMERICAN PEOPLE**

Purses for all Purses

WHY LOOK ELSEWHERE TO SUPPLY YOUR STOCK?

From the simple and inexpensive trinket of the unassuming to the most aristocratic and costly conceits. Each grade conceived to meet the taste of some one element of society and all together constituting a line of the greatest possible extent. In the designing, etching and engraving the whims of all the feminine world have been studiously consulted and artistically incorporated with the idea of producing something appealing and consequently easily sold.



The line must recommend itself to the jeweler carrying combination purses and card case, and satchel shaped box purses, for the reason that we can supply these novelties in a practically unlimited variety, from the smallest to the largest made. We have oblong or satchel shaped purses with silk or leather linings; several sizes of vanity boxes, with silver compartments or leather lined, with puff, mirror, pencil tablet and change compartments, and many others, all of sterling silver, that we couldn't begin to enumerate in this space. See the line to understand it.

Representative jewelers are invited to send for a selection. State whether high, medium or low-priced goods are desired.

R. BLACKINTON & CO.

ESTABLISHED 1861. SILVERSMITHS

Factory, North Attleboro, Mass.

3 MAIDEN LANE, NEW YORK

TRADE  MARK

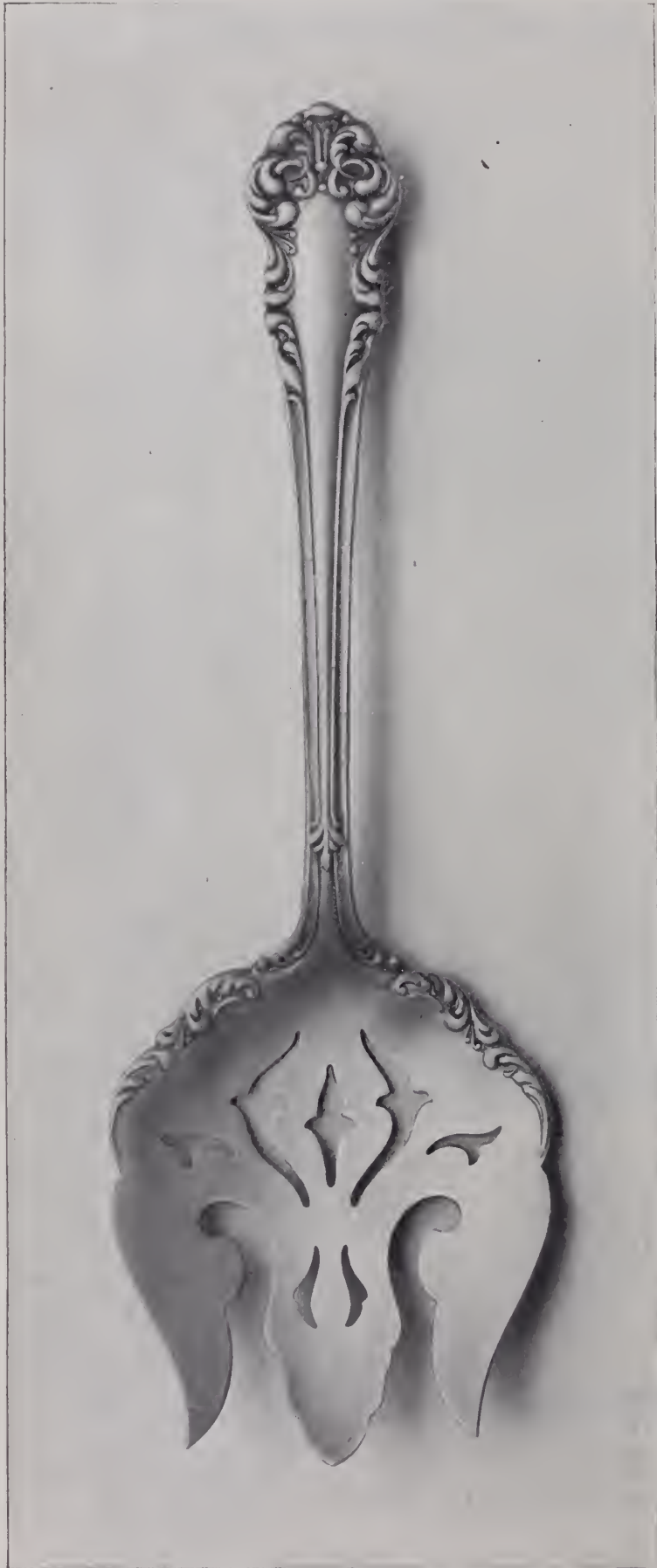

AVALON DESIGN.

IT TAKES a live fish to swim up stream, but a *wise* one follows the current—and gets into smooth water first.

Swinging sharply away from expensive luxuries, the present trade current has set strongly towards moderate priced staples,—such as good plated ware for example.

Follow the current! Buy

COMMUNITY SILVER

Display it. PUSH IT.
There is good profit in it.

Take what smooth going comes your way. *Don't swim up stream just to show you can.*

ONEIDA COMMUNITY, Ltd.

ONEIDA, N. Y.

Chicago Salesrooms
Silversmiths' Bldg.

New York Salesrooms
395 Broadway



Individual Communion Sets

Our Communion Sets with individual cups are illustrated in our new catalogue, together with our latest designs of the conventional type, also accessories, pew-racks, cup fillers, etc. We also produce collection plates, alms basons, chalices, crucifixes, vases, etc., in sterling silver, as well as gold and silver plate. The quality of all ware bearing the MERIDEN BRITANNIA Co. stamp is of the highest.

Send for New Illustrated Catalogue No. 78-C.

MERIDEN BRITANNIA COMPANY

International Silver Co., Successors

MERIDEN, CONN.

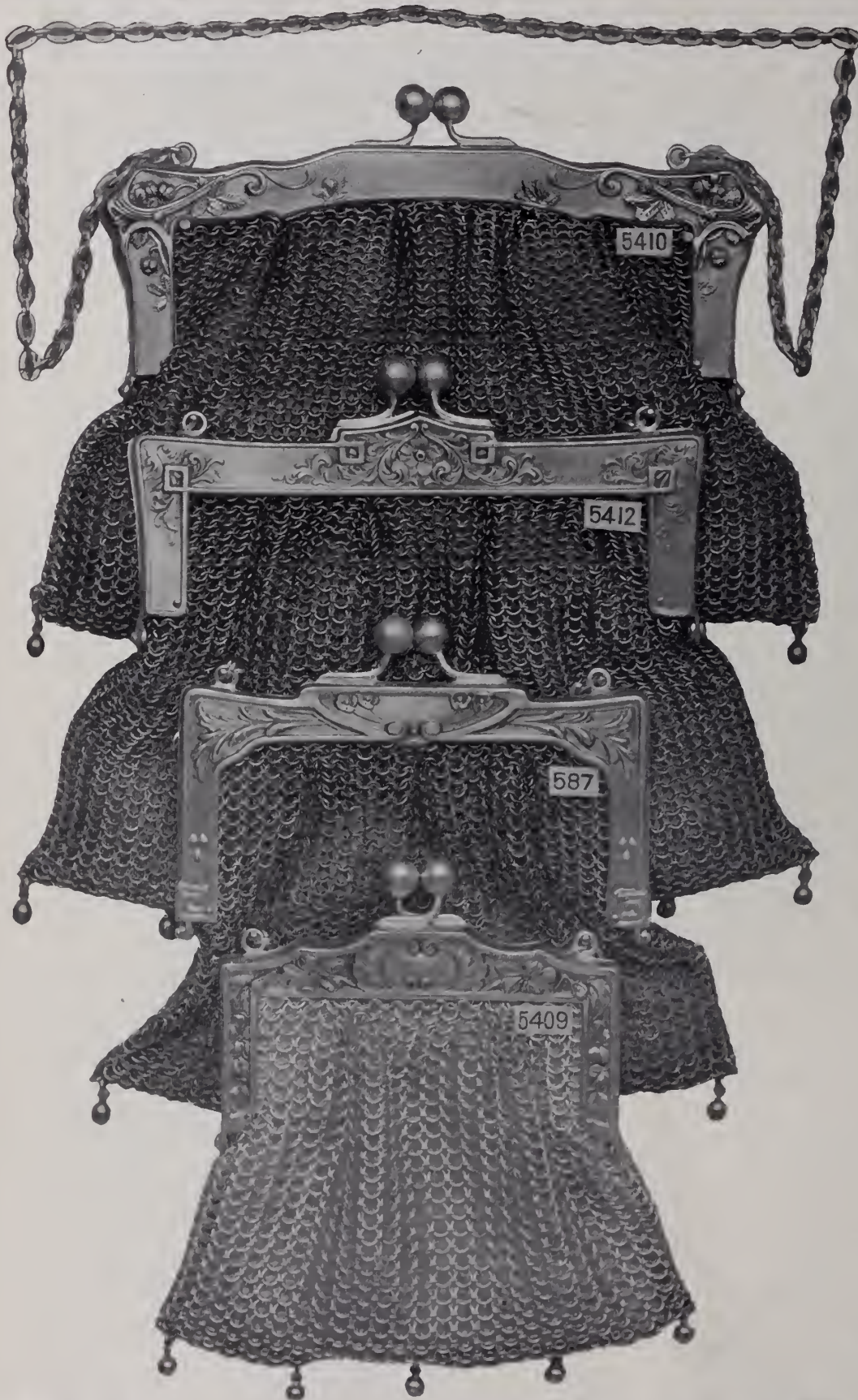

SEE OUR
NEW GOODS

GET OUR
1908 PRICES
and
TERMS

Largest Line
of
BAGS; BUCKLES,
SASH PINS,
BRACELETS, and
HAT PINS
made by any one
house

OUR FINISH AS
EVER
"THE BEST"

See Our Representative

THE W. H. SAART CO.

SILVERSMITHS

NEW YORK OFFICE: 49 Maiden Lane.

ATTLEBORO, MASS.

Hutchison & Huestis

RING MAKERS

FOR THE JOBBING TRADE

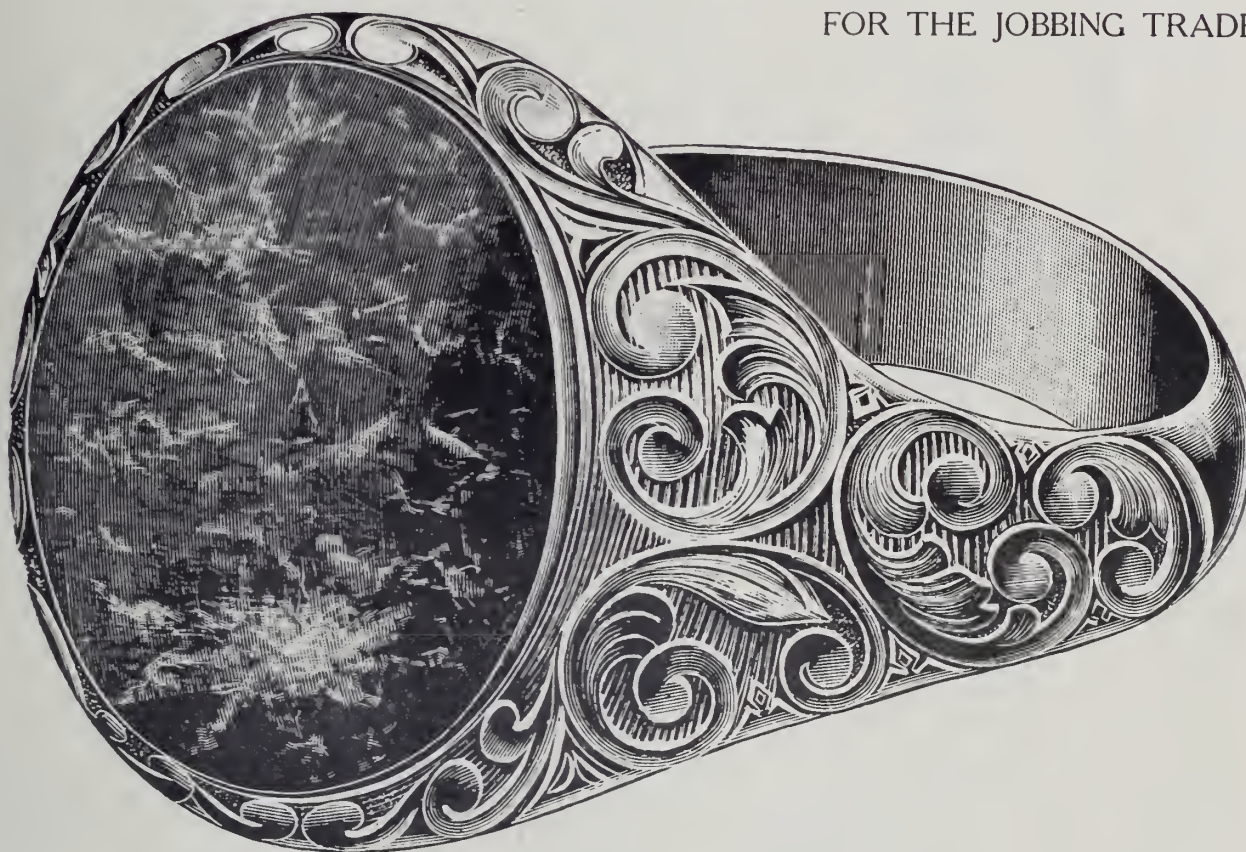

STONE RINGS

Made in

Amazonite
Lapis Lazuli

Opal Matrix
Bloodstone

Sardonyx
Jade

Signet Rings

Diamond Rings

Serpent Rings

Diamond Mountings

NEW YORK
3 Maiden Lane

FACTORY
185 Eddy Street
PROVIDENCE, R. I.

CHICAGO
Columbus Building
HARRY H. MILLER



THE jobbers' salesmen are out—buying time is here and the selling season is coming.

Buy the right goods now and you need have no anxiety about your sales later on; so select your Spring stock wisely.

It's practically certain that there's going to be a normal demand for standard and dependable goods. No jeweler need hesitate to order **Simmons Chains, Fobs and Bracelets**, for they're always salable—staple as flour, safe goods to have in stock at all times.

Simmons goods are the best known goods of their kind; their quality and wearability are unquestioned. They have been and are advertised as no other like goods have ever been advertised.

It will pay you to see the Simmons line for 1908; it will pay better to make a generous selection of the newest patterns and feature them in your Spring displays.

R. F. SIMMONS COMPANY

Main Office and Works, ATTLEBORO, MASS.

NEW YORK SALESROOMS
9-13 Maiden Lane

CHICAGO SALESROOMS
42 Madison St. (Heyworth Bldg.)

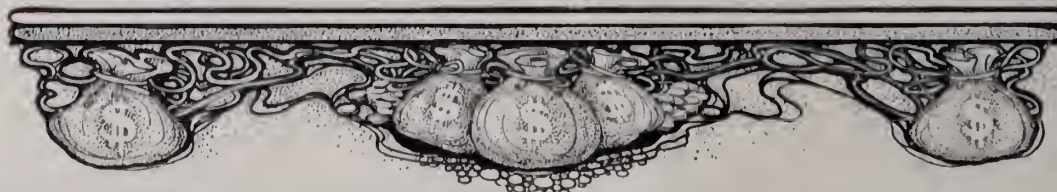

Attractive and Unique Patterns in Up-to-date Jewelry

Orders Prove That Our Goods Sell

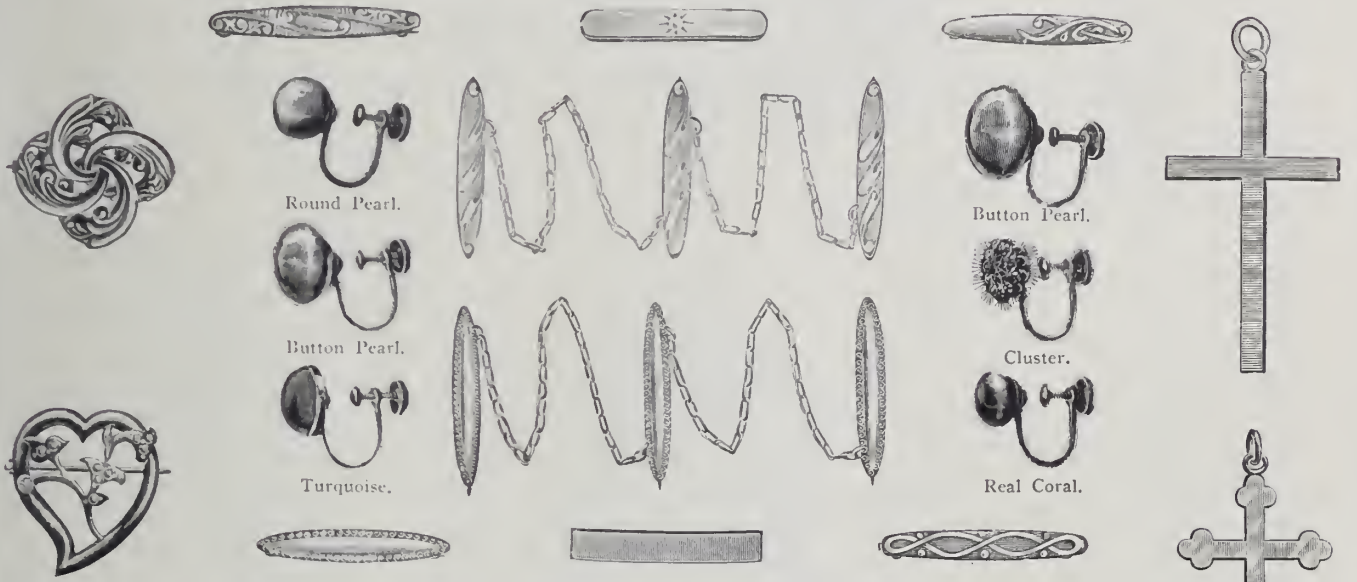
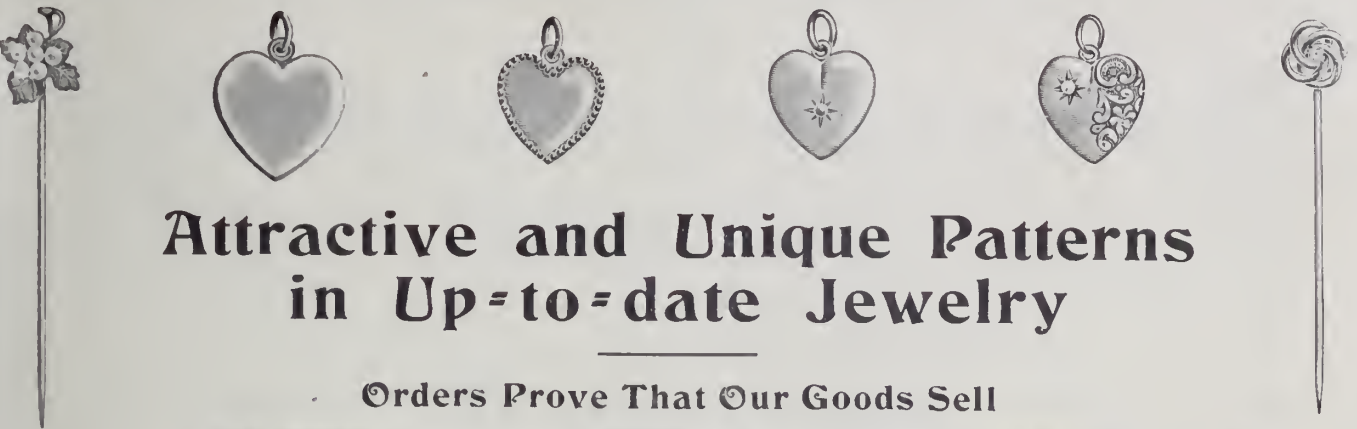

¶ The style and character of design is the great selling asset of our products. ¶ Our specialty is in the making of 10 Kt. Jewelry to meet the demand of the trade "who know" and want inexpensive jewelry in artistic and novel effects. ¶ Our 10 Kt. Novelties are equal in design to the most expensive jewelry, are of excellent workmanship, and will give entire satisfaction.

We make for the Jobbing Trade the following line of Solid Gold Jewelry:

- | | | |
|-------------------|-----------------------|--------------------|
| RINGS | BABY PINS | CROSSES |
| SCARF PINS | HANDY PINS | EAR SCREWS |
| STUDS | CHAIN SETS | SWING DROPS |
| BROOCHES | LINK BUTTONS | WAIST SETS |
| CHARMS | HAIR BARRETTES | Etc., Etc. |

INSIST UPON SEEING THE DESIGNS OF GOLD JEWELRY MADE BY THE

E. L. SPENCER COMPANY

95 Chestnut Street, Providence, R. I.

New York Office, 9-11-13 Maiden Lane

Samples Only

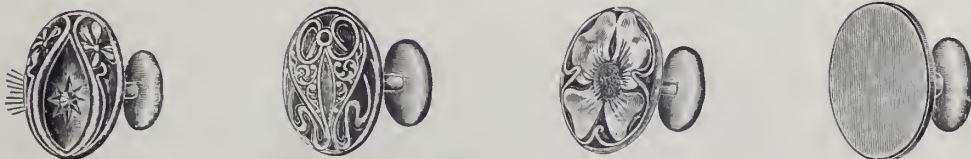

EVERYTHING in
LOCKETS
and
..... CHAINS



THE BASSETT JEWELRY CO.

PROVIDENCE, RHODE ISLAND

NEW YORK :: CHICAGO :: MINNEAPOLIS :: SAN FRANCISCO

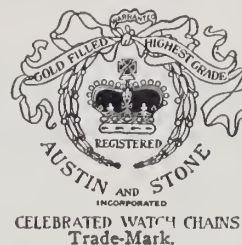
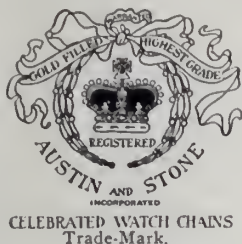

THE "If for Any Reason" Chain Line

GUARANTEE :



IF FOR ANY REASON THIS CHAIN IS NOT SATISFACTORY TO THE PURCHASER, IT CAN BE RETURNED TO THE MAKER AND A NEW CHAIN WILL BE GIVEN IN EXCHANGE
AUSTIN & STONE, INC.
Attleboro, Mass.

THIS GUARANTEE WITH ALL OUR GOODS.



We make
Fobs,
Bracelets,
Vest, Neck
and
Guard Chains,
La Vallieres
and
Friends.

Genuine Cameos, Shell or Stone, in great variety. Ask your Jobber for them, or write to us and we will give you a list of your nearest Jobbers handling the "If for Any Reason" Line.

Write for New Pamphlet. Just Out.

AUSTIN & STONE, Incorporated, ATTLEBORO, MASS.

NEW YORK:
9 Maiden Lane

Bates & Bacon

CHICAGO:
103 State Street

ATTLEBORO, MASS.

THE LEADING HOUSE FOR
**LION AND TIGER-HEAD FOBS
LOCKETS AND BRACELETS**

High Grade, Gold Filled

Our Line comprises Gents' Vests, Dickens, Safety Fobs, Lor-
nettes, Bracelets, Secret Locket Chains, Locketts
and Eye-Glass Chains

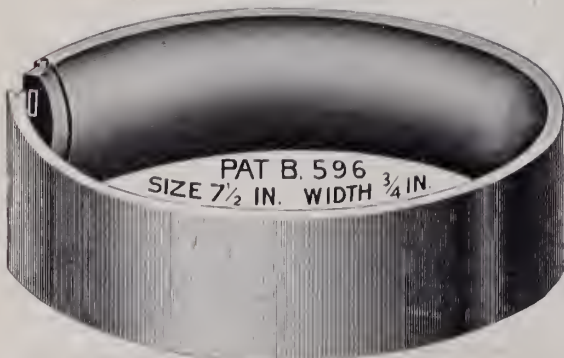
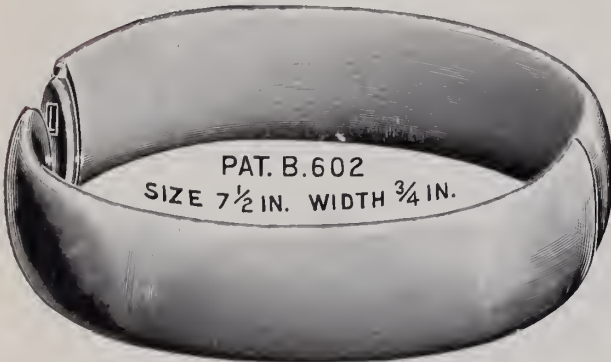
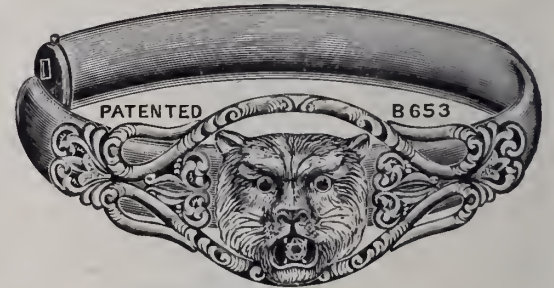
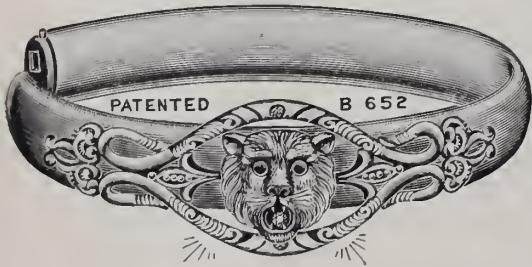

THE "WINNA" BRACELET

the strongest and
best secret hinge
and joint bracelet
on the market, is a

BIG SUCCESS

Wolcott Manufacturing Co.

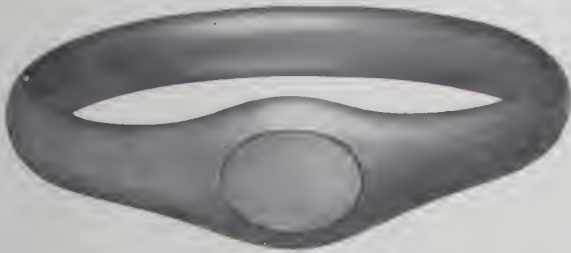

384 SIGNET ROMAN
386 " ENGLISH

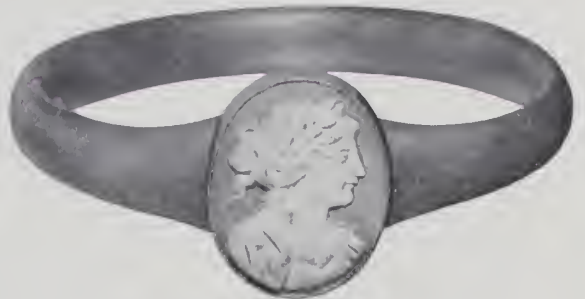

398 CAMEO ROMAN
399 " ENGLISH



400 ENGRAVED ROSE
401 " ENGLISH

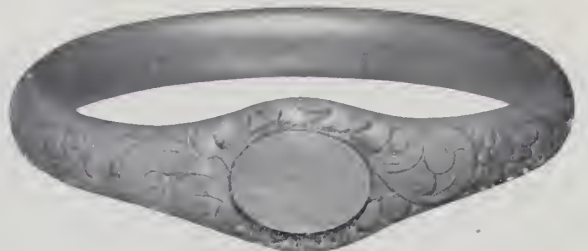

388 ENGRAVED ROSE
390 " ENGLISH

WITH STYLES SUCH AS THESE
THE WOLCOTT LINE EASILY LEADS

WOLCOTT MANUFACTURING CO.

71 PECK STREET, PROVIDENCE, R. I.

New York Office, = = = = = 14 Maiden Lane



CUFF BUTTONS
 IN EVERY POSSIBLE VARIETY
 WE ARE THE LARGEST EXCLUSIVE MAKERS OF 10-K JEWELRY
 ASK YOUR JOBBER FOR P. & B. LINES OF
 Cuff Buttons, Crosses, Beadnecks, Tie Clasps,
 Brooches, Baby Pins, Scarf Pins, Bracelets,
 Locketts, Fobs.

NEW YORK
 OFFICE
 65 NASSAU ST.

POTTER & BUFFINTON CO.
 PROVIDENCE, R.I.

P & B BABY PINS



BABY PINS—ALL DESIGNS
 SUITABLE FOR BABIES OR GROWN-UPS
 We are the Largest Exclusive Makers of 10-K Jewelry.
 Ask your jobber for the P. & B. Lines of Cuff Buttons, Crosses, Bead Necks, Tie Clasps,
 Brooches, Baby Pins, Scarf Pins, Bracelets, Locketts and Fobs.
 NEW YORK OFFICE, . . . 65 NASSAU ST.

POTTER & BUFFINTON CO.
 PROVIDENCE, R.I.

THE P & B



Watch Fobs
 ALL STYLES AND PRICES,
 Both in RIBBON and ALL GOLD

We are the Largest Exclusive
 Makers of 10-K Jewelry

Ask your Jobber for the P. & B.
 lines of Cuff Buttons, Crosses, Tie
 Clasps, Brooches, Baby Pins,
 Beadnecks, Fobs, Locketts,
 Scarf Pins and Bracelets.

NEW YORK OFFICE:
 65 Nassau Street

**POTTER &
 BUFFINTON CO.**
 PROVIDENCE, R.I.

O. M. Draper Chains

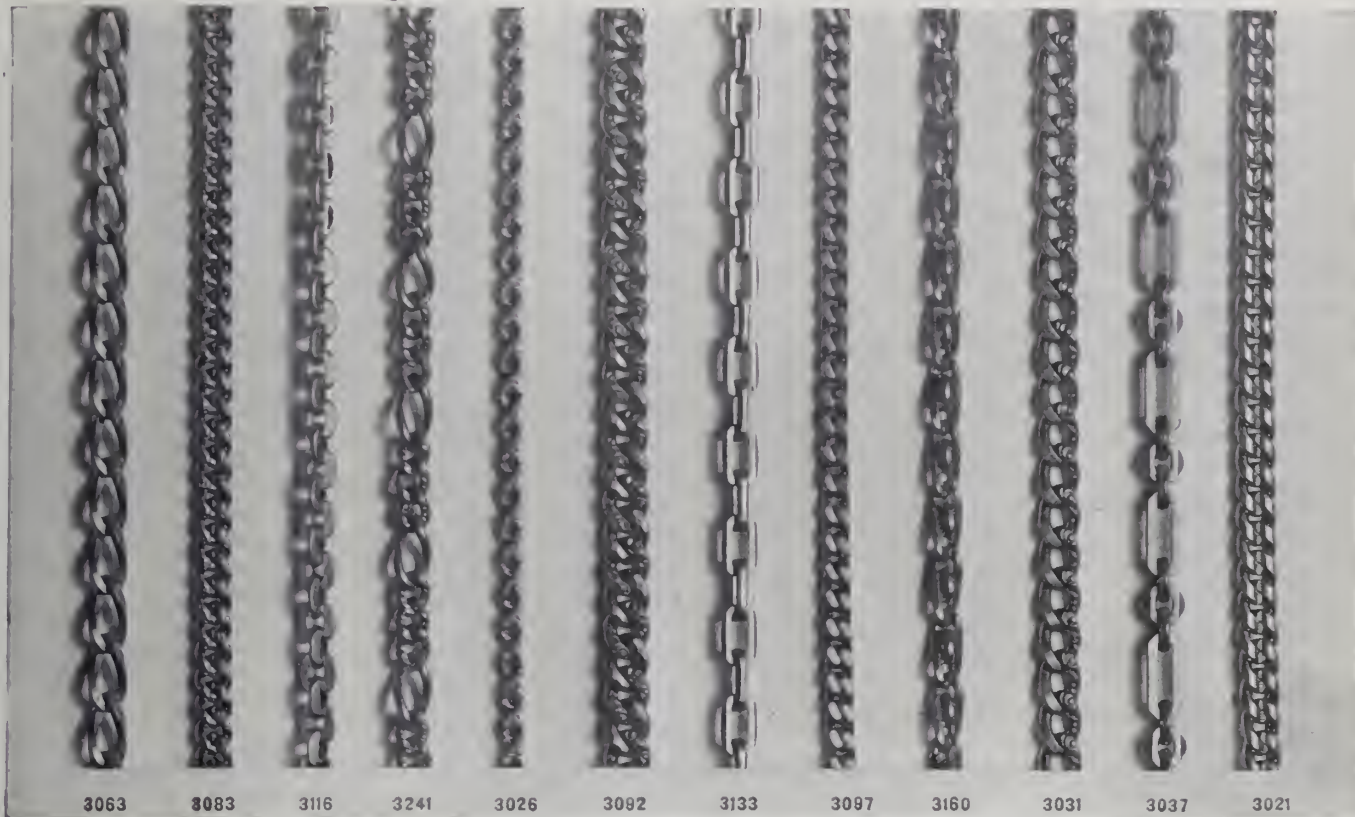

There is no surer method of increasing your sales and consequent profit for the year 1908 than by adding to your stock a thoroughly satisfactory line of chains.

A chain to be satisfactory must not only be guaranteed in every particular, but must be in and of itself a guarantee and give satisfaction to the wearer.

For nearly half a century the O. M. Draper Chains have fulfilled all these requirements.

Our Motto: SUPERIOR QUALITY, ARTISTIC DESIGN, UNPARALLELED FINISH.

We show above a few of the large variety of patterns of our one-tenth seamless gold filled line. Ask your jobber for them.

“O. M. D.” Adjustable Bracelet

Our Bracelet is a distinct innovation as far as Extension Bracelets are concerned. All of the defects common to Bracelets of this sort are eliminated in the “O. M. D.” Adjustable. No pins or rivets are used in its construction; parts are securely locked together, and no solder is used, which leaves the gold hard and preserves its wearing qualities. Repairs are reduced to a minimum. The Bracelet is made of extra heavy gold filled stock, is reversible, flexible and firm, and is beautiful in design and finish, and a money maker for the jobber and his customer who handles it.

Made in all desirable signet and locket tops. Bright, Old English, or Roman finish.

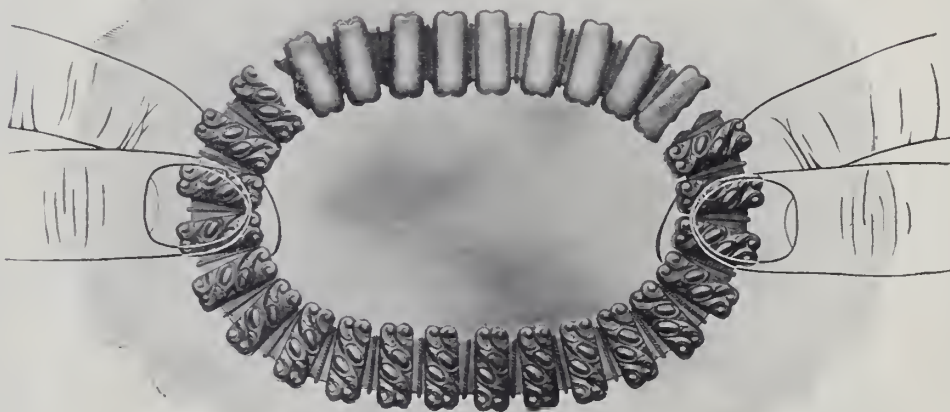

Estate of O. M. DRAPER

North Attleboro, Mass.
Factory

San Francisco, Cal.
503 Chronicle Building

37 Maiden Lane
New York

To Men Who Smoke

Sternau Smokers' Articles

appeal strongly, because they are handsome, convenient and useful

Jewelers should stock Sternau Smoking Sets, Ash-receivers, Match-holders, etc., which are salable throughout the year.

Each style has the necessary elegance demanded by the jewelry trade.

The Ash-receiver with Match-box Holder and two Cigar-rests shown here is novel.

Let us prove our wares will be profitable for you to sell. Catalog, 21-Y, sent on request.



S. STERNAU & COMPANY

Makers of

STERNAUWARE

Consisting of

Coffee-machines, Fancy Teakettles, Chafing-dishes and their Accessories, Smoking Sets, Alcohol-stoves, Candlesticks, Trays, etc.

New York Showrooms
BROADWAY, COR. PARK PLACE
Opposite Post-office

Office and Factory
195 PLYMOUTH STREET
BROOKLYN, N. Y.



ASH-RECEIVER

WITH TWO CIGAR-RESTS
AND MATCH-HOLDER

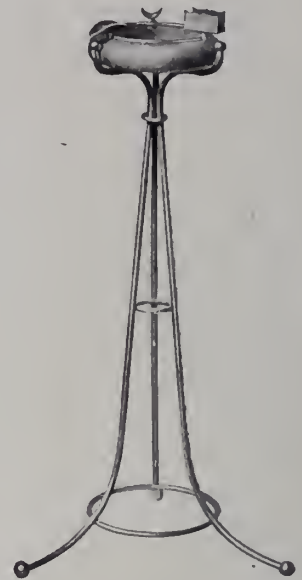

No. 927

Height of Stand and Ash-Receiver,
24 $\frac{1}{4}$ inches; diameter of Ash
Receiver, 6 inches.

Made in Old Brass, Nickel-plate,
Copper and Silver-plate.

MANUFACTURERS TO THE RETAIL TRADE.

Why pay a jobber's profit when we sell you direct?

We make $\frac{1}{16}$ gold filled chain at prices that defy competition, and guarantee the quality.



Send for a selection to-day and compare our values with others. If our claims are not endorsed by the goods, return them at our expense.

Chains and Fobs Exclusively.

The only Exclusive Chain Makers for the Retail Trade.

THE A. & Z. CHAIN CO.,

9 Calendar Street, Providence, R. I.

NEW YORK

CHICAGO

SAN FRANCISCO

KANSAS CITY

25-9738

DORAN, BAGNALL & CO.

MANUFACTURERS OF
FINE ROLLED AND STERLING
GOLD PLATE AND SILVER

Chains, Bracelets and Novelties

JOBBERS cannot afford to slight this line if they want some of the newest and best-selling novelties of the season. Have a look; it won't cost you anything and you won't regret it.

DORAN, BAGNALL & CO.

NORTH ATTLEBORO, MASS.

Established 1870.

New York: 194 Broadway Chicago: 42 E. Madison St. San Francisco: 91 Drumm St.

Address all correspondence to Main Office, North Attleboro, Mass.

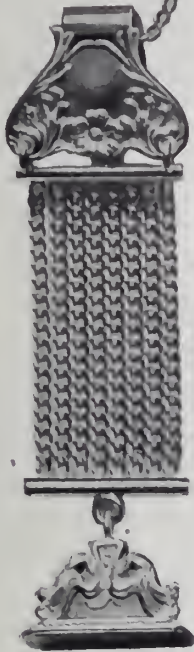

4468-4451X1.

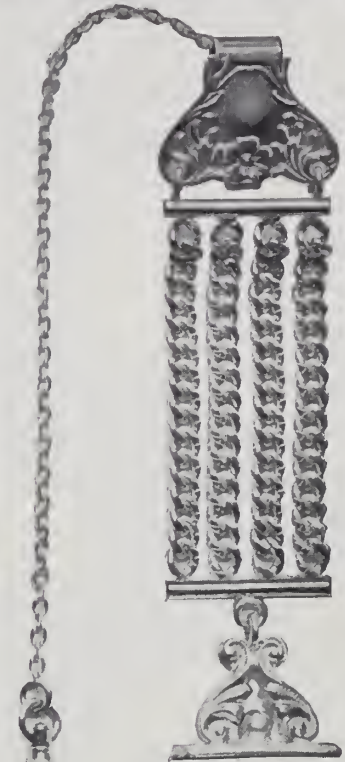

4481-878X3.

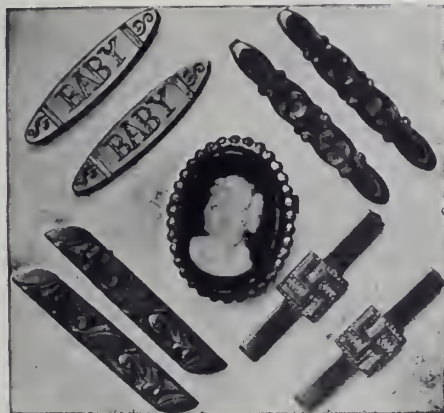

New Creations for 1908

Our lines for the Spring trade include many new creations in addition to our already staple patterns—all acknowledged to be highly artistic, of attractive quality and rapid sellers.

Don't fail to see our immense lines of

- | | | |
|-----------|-----------|-------------------|
| Lace Pins | Buttons | Hat Pins |
| Cuff Pins | Charms | Scarf Pins |
| Buckles | Barrettes | Brooches |
| Bracelets | Combs | Leather Trimmings |



We also carry a large line of STONE and SHELL CAMEOS mounted in Brooches, Stick Pins, etc. A glance over this line will prove to you that we have the Premier Line. The highest class of workmanship is characteristic of all our lines.

SOLD THROUGH THE JOBBING TRADE ONLY

Miller, Fuller & Whiting Co.

Manufacturing Jewelers

New York Office
9-11-13 MAIDEN LANE

NO. ATTLEBORO, MASS.

TRADE-MARK



ALWAYS
ON
THE
GO

THE CHAS. M. ROBBINS CO.

MANUFACTURING JEWELERS ATTLEBORO. MASS.



WE MAKE

a Large Line of Scarf Pins, Brooches, Rings, Baby Pins, Links, Crosses, Tie Clasps, and Ear Screws, both with plain and fancy stones.

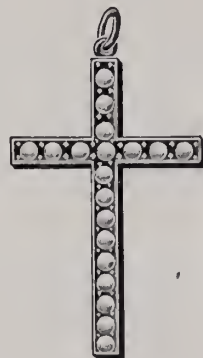

CROSSES

Our line will be a revelation to you. We have given the simple cross such a diversity of artistic interpretations that the line in extent and beauty easily leads. All sizes and prices.

OUR VARIOUS LINES SHOULD INTEREST THE JOBBERS

WM. C. GREENE CO. PROVIDENCE, R. I.
101 SABIN STREET



PRIZES
TROPHIES
MEDALS AND AWARDS
FOR ATHLETIC CONTESTS
SCHOLARSHIPS
DEBATES
ETC

THE PERGOLA

BUTLER COLLEGE

CHICAGO SCULPTURE CLUB

MEDALS

THE CHAS. M. ROBBINS CO.
MANUFACTURING JEWELERS AT TLEBORO, MASS.



Lyons Manufacturing Co.

(Successors to Wm. Loeb Co.)



Seamless Gold Shell Rings and Bracelets

Providence, R. I., U. S. A.

NEW YORK
37 Maiden Lane

CHICAGO
1108 Heyworth Building





REPORTS from the trade throughout the country indicate the holiday business was generally satisfactory, particularly so in moderate price gold jewelry and watches, which have always been strong features of our stock. Our lines this season will therefore be particularly adapted for the present conditions and demand, and we will more than ever be "SELLERS OF SELLERS." One of our representatives will shortly call on you.

HENRY FREUND & BRO. 71 Nassau Street NEW YORK

EAGLE AND ELK GOODS A SPECIALTY

Jewelry, Watches, Diamonds



Our Trade-Mark "The  Rose" stands for quality and excellence and is equal to a Government stamp.

"GOLD-MEDAL" BRACELETS

"Long Worth"

ADJUSTABLE ARMLET

Newest Flexible Gold-Filled Wire Bracelet



PROVIDENCE STOCK CO. BRACELETS

Sold Through the Jobbers Only

9-11-13 Maiden Lane
NEW YORK CITY

100 Stewart Street
PROVIDENCE, R. I.

131 Wabash Avenue
CHICAGO, ILL.

"SE CUR ON"

"GERALDINE FARRAR"-BRACELETS.

High Quality Gold-Filled, all Sizes, Styles, Widths



Guarantee Mark **PR. ST. CO.** on all Bracelets

This merit mark means an insurance of satisfaction given gratis with all our Security Protector Bracelets.

Demand "Se Cur On" Guard Bracelets from Jobbers

Catalogue to all upon request to Providence, R. I.

Begin the New Year Right—Complete Your Stock with Right Goods

GOLD RINGS

Gold Scarf Pins

Gold Brooches

A Handsome Line of Seamless Wire GOLD FILLED RINGS

All ready for prompt delivery to the Jobber

OSTBY & BARTON CO.
PROVIDENCE, RHODE ISLAND

New York Office
9-13 MAIDEN LANE

Chicago Office
103 STATE STREET

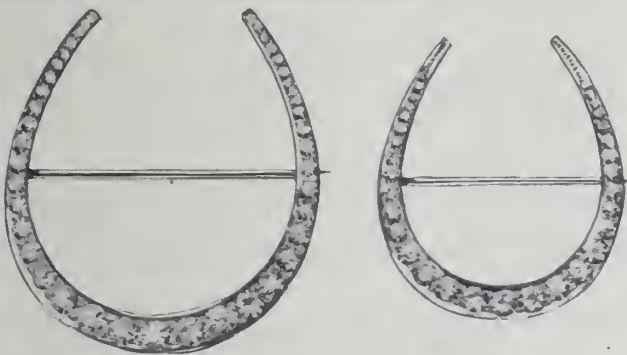

Fine Gold Jewelry for the Jobbing Trade Only

☞ Ladies' and Gentlemen's

- | | | |
|-------------|----------------|--------------|
| STONE RINGS | DIAMOND RINGS | SIGNET RINGS |
| BRACELETS | BROOCHES | SCARF PINS |
| EAR STUDS | EAR DROPS | HANDY PINS |
| | and BAND RINGS | |

THE EDWIN LOWE & CO., Inc.

116 Chestnut Street

Providence, R. I.

FRANK W. BODWELL, President and Manager

New York Office, 180 Broadway
E. T. WILSON

Western Representative
S. H. BROWER



WE show herewith a new style bag—an exceptionally strong, stylish, snappy article.

Our new Spring line is complete—covering the entire range of bags—all shapes, all the different styles of mesh—the largest assortment of frames ever shown. Every piece stamped. W. & D. an absolute guarantee of satisfaction.

Your Jobber has them.

WHITING & DAVIS
PLAINVILLE (Norfolk Co.), MASS.

New York Office, 7 Maiden Lane

Silversmiths' Bldg.
131-137 Wabash Ave.

C. G. Breitenbach & Co. CHICAGO

ESTABLISHED 1889

Largest Distributors of Silver-Plated Ware in the World



No. 1904.—A. D. Coffee Set Hand Engraved.



¶ We are also headquarters for the E. H. H. Smith high-grade Art Silver-Plated Flat Ware, the highest grade Silver-Plated Ware in the world. ¶ Sterling quality and patterns.

Important

We call particular attention to our Catalogue No 20, the most complete book of its kind published, as something which every buyer should have. No end of items which will interest you in silver-plated ware, tableware, cut glass, novelties, etc. Write for it.

C. G. BREITENBACH & CO.
Manufacturers and Importers
131-137 Wabash Ave., Chicago

“LEST YOU FORGET”

We are one of the oldest Silverware Manufacturers in the United States. Established 1869



Our Designs, Quality and Workmanship are unsurpassed. Our Prices are right.

No. 0233. Tea Set: Chased; Embossed.

Aurora Silver Plate Manufacturing Co.

Manufacturers of the HIGHEST QUALITY OF SILVER PLATED WARE,

Aurora, Illinois

The Only Manufacturers in the Line Selling Only to Retail Jewelers Direct

SOLD WITH PROFIT BY THE RETAIL JEWELER.



IF YOU HAVEN'T SEEN OUR LINE, WRITE AND ONE OF OUR SALESMEN WILL CALL.

Rockford Silver Plate Co.

ROCKFORD, ILL.

“Stand By Those Who Stand By You”

WE PROTECT EVERY RETAILER OF ROCKFORD GOODS

C. P. Goldsmith & Co.



Hand Carved
Mountings
BRACELETS

Link Buttons	Collarettes
Diamond Mounted Jewelry	Scarf Pins
Pendants	Brooches
Diamond Platinum Jewelry	
Signet Rings	Set Rings

EXCLUSIVE DESIGNS

33 Gold Street

NEW YORK





"THE" MACHINE for TAGGING RINGS, Etc.

Price Complete
\$5.00 Net

Hand Pliers are useless for Tagging Rings



NO. 1.

For Rings



NO. 2.

For Rings
STYLE OF TAGS.

Style of Tags



NO. 3.

For Chains



NO. 4.

For Scarf Pins

Complete Outfit Consists of

- Our Eyelet Machine
- 1000 Celluloid Tags
- 1 Bottle Ink



Patented June 16, 1906.

The HOLD-ON CLUTCH

Best
Safest
Simplest

*YOU slide the Clutch on—
IT does the rest*

A SPLENDID SELLER
RETAILING AT 50 CENTS

SCARF PIN INSURANCE

Patented May 20, 1902.



ASK YOUR JOBBER OR WRITE TO
HOLD-ON CLUTCH CO., 33 Gold Street, NEW YORK

“If it is Chopard’s Idea, it’s Ideal”

“Confidence Begets Confidence”

With unbounded Confidence in the FUTURE, our GOODS and YOU, we solicit your interest in our wares

Fancy Jewelry The demand for staples is constant but there is a growing one for the new, the odd, the different, the something that others have not, and this long-felt want we are supplying from a stock replete with surprising creations.

Pearls Which have become a standard for comparison by the discriminating trade; so superbly tinted and with sheen so natural that only an expert can differentiate between the real and artificial.



Jets Of superlative creation, each and every piece a work of art and refined beauty.

Styles Always in advance of others.

Quality Ever better than the other’s best.

Prices Less than paid for inferior goods and only possible because we import direct from our own factories, in other words:

**THROUGH US
FROM PARIS
TO YOU**

Factory
35 Rue des Trois Bornes
Paris, France

CHOPARD FRÈRES

49 MAIDEN LANE
NEW YORK, N. Y.



Fishel, Nessler & Co.

Silversmiths and Jewelers

Largest Makers of White Stone Jewelry in the World : : :

¶ There is nothing better for the spring trade than Sterling Silver Horse Shoe Pins set with our brilliant white stones that sparkle like diamonds. ¶ There is no surer way of increasing your sales than by showing a good assortment of this popular pin. ¶ We predict a big season for the following articles: Horse Shoes, Veil Pins, Combs, Barrettes, Neck Chains and Buckles. ¶ Let us send you a few samples for your approval.

Fishel, Nessler & Co.

Office and Works : 79-81-83-85 CROSBY STREET
Salesroom : 556 BROADWAY, NEW YORK

Fast Sellers



Mesh Bags
Purses
Card Cases
Buckles
Picture Frames

*Engraved
and
Etched*

We have a line of the above second to none

Write us

Pryor Mfg. Co.

Silversmiths

New York Office
7 MAIDEN LANE

473-75 WASHINGTON STREET
NEWARK, N. J.

No. 1220 C.—Engraved Combination Purse and Card Case, Sterling Silver and 14K. Gold.

THE HAGERSTROM CO. (Incorporated)

MAKERS OF JEWELRY

OFFICE and WORKS, 276 N. J. R. R. Avenue

NEWARK, N. J.

OUR DESIGNS are original and our goods are inexpensive and salable. We beg to call your particular attention to our novelties in Handy Pins, Scarf Pins, Brooches and Veil Pins.

THEY ARE SELLERS



No. 1093.

BE SURE to look over our line when our salesmen call—it will be to your advantage. We have the largest line of Necklaces and La Vallieres now on the market. *They are beauties* and are made at salable prices.

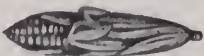

No. 324.

Set with Half Pearls and Enamel



No. 326.

Set with Amethyst, Jade, Amazonite, Red and Green Sardonyx, etc.



No. 325.

Finished in Rose and Enamel

The Original Makers of the Universally-Popular FEATHER PINS

Made in Six Sizes—Plain and with All Precious Stones

Also a General Line of Strictly
14 K. Jewelry

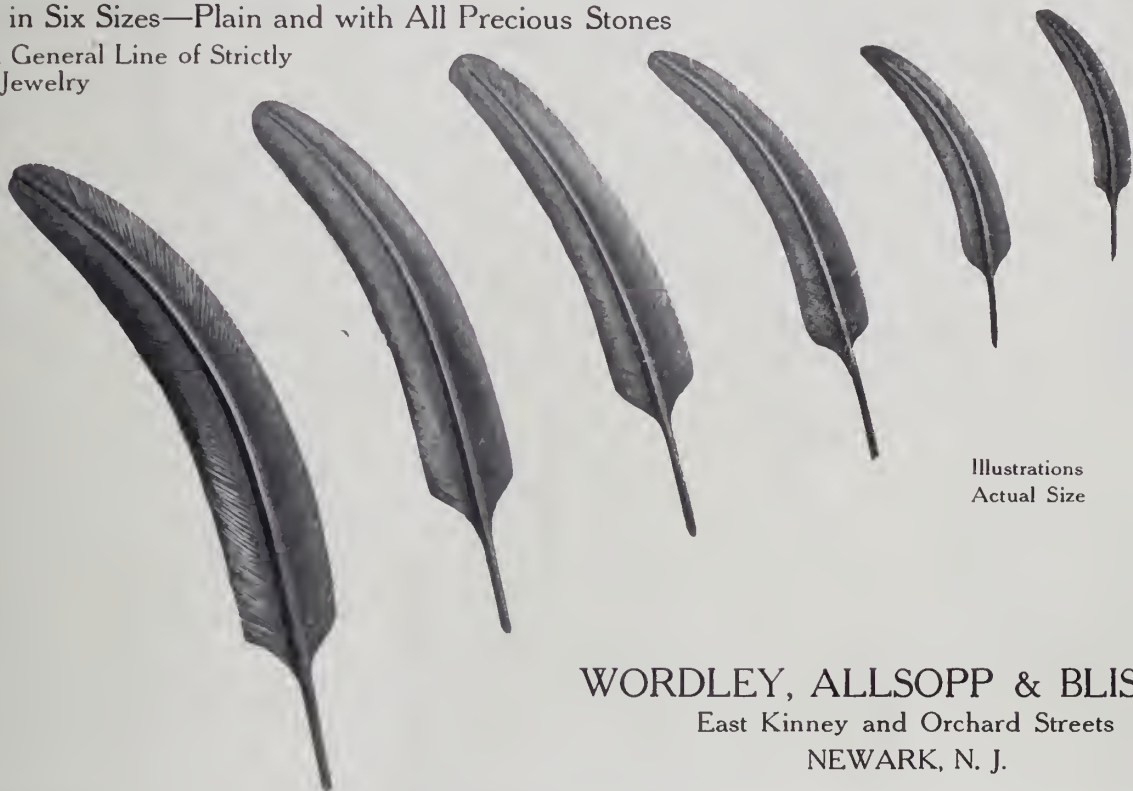

Illustrations
Actual Size

WORDLEY, ALLSOPP & BLISS CO.
East Kinney and Orchard Streets
NEWARK, N. J.

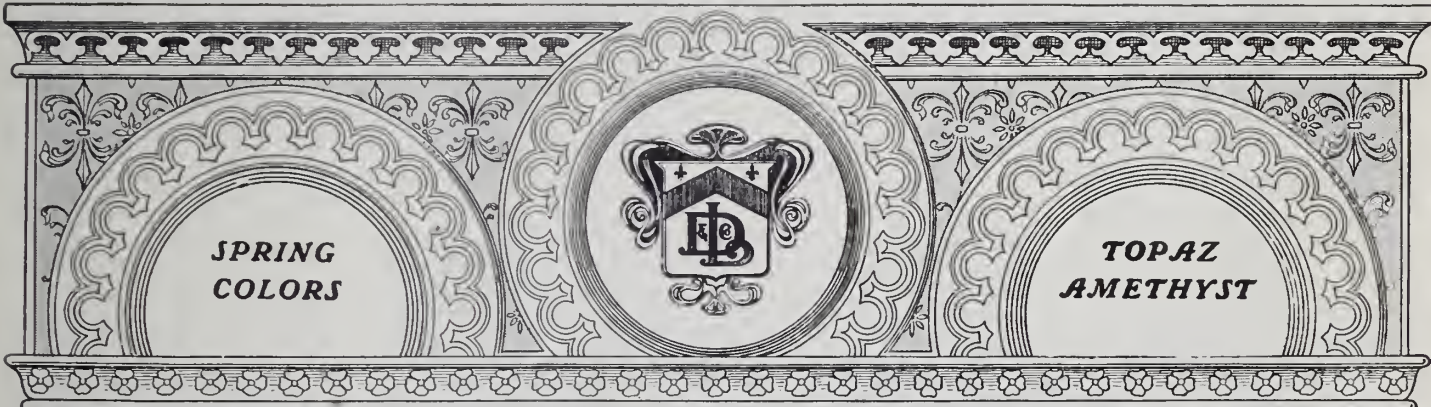

WHEN BUD AND BLOSSOM begin to peep forth, it is in order for jewelry to take on the dainty tints of Spring—the delicious purples and yellows that overspread vale and hill. Stones used in the creations here always have the charm of seasonable color, and the present showings pay their tribute to Spring. The yellow Topaz and purple Amethyst in fine imitation stones embodied in

NECKLACES, COMBS, HAT PINS, BROOCHES, BELT PINS

D. Lisner & Co. *Creating Importers of* *Jewelry Novelties*
One-Forty Fifth Avenue, cor. 19th St., NEW YORK

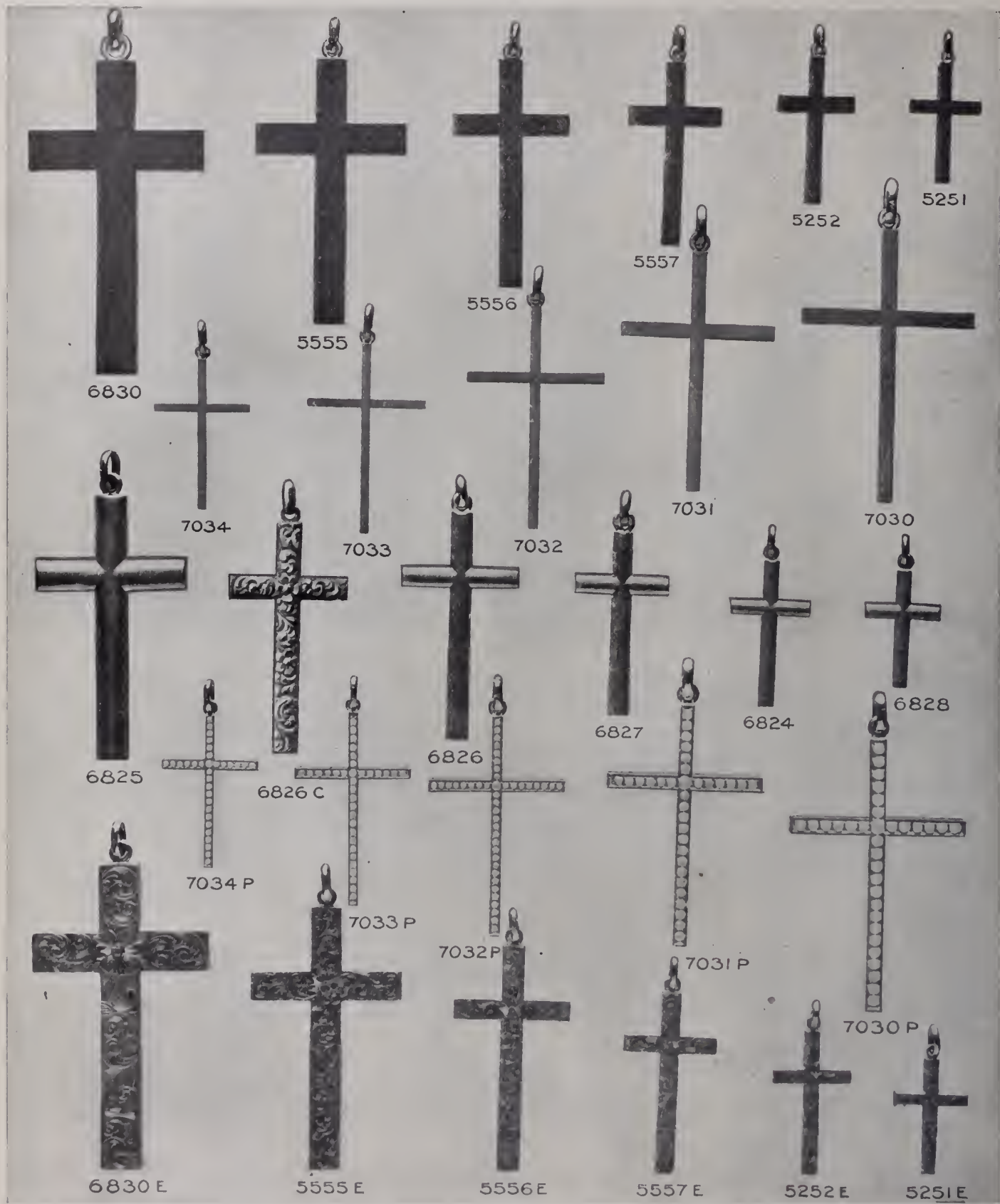

T. W. ADAMS & COMPANY

11 JOHN STREET
NEW YORK

Factory

83 UNION STREET
NEWARK, N. J.

TRADE A 14 K MARK

Manufacturers of 14K. Exclusively

Chicago Office

103 STATE STREET

Illustrations showing full line furnished upon application

THE FAMOUS
ALFRED SCHICKERLING ELK AND EAGLE JEWELRY
 IS THE FINEST IN THE COUNTRY

**ELK
 MEMBERSHIP
 CARD CASE**



PATENTED

Made in,
 14 Kt. Gold, 10 Kt. Gold,
 Sterling Silver, Sterling
 Plate, Bronze, and
 also Filled Gilt



PATENTED

OUR ELK HEADS

are the best ever
 made for the Order



ALFRED SCHICKERLING
 Inventor and Patentee



PATENTED

We make same on
**Card Cases, Buttons,
 Charms, Cuff Links,
 Brooches, Rings,
 Fobs, Buckles
 and Scarf Pins**

in 14 Kt. and 10 Kt. Gold, Sterling,
 Bronze, and Filled, in Various Sizes

**This Eagle Member-
 ship Card Case**

is the finest article of its
 kind. Prices upon re-
 quest. Made in 14-kt.
 and 10-kt. Gold, Sterling
 Silver, Silver Plate, Gray
 Finish, and Bronze, also
 Rose Finish.



PATENTED

Beware of Imitations.

All our goods have
 patent stamp on back
 which guarantees both
 the Quality of Metal
 and Workmanship. All
 goods are Designed and
 Modeled by the patentee
 ALFRED SCHICKERLING

THE ELK JEWELRY MFG. CO.

Manufacturers of the Finest Elk and Eagle Goods in America

E. R. SHEPPARD, Representative for the Middle West

51-53 MAIDEN LANE, NEW YORK



Pink enamel for baby boys;
 Turquoise enamel for baby girls;
 Black enamel for mourning wear;
 White enamel for summer gowns
 Paved all over with pearls for the young miss;
 Roman gold for all kinds of wear—
 Hand-engraved and all the other finishes;

WE MAKE THEM ALL.

MOURNING GOODS
 A SPECIALTY



TRADE-MARK

A. J. HEDGES & CO.

Makers of 14-K. Jewelry

14 JOHN STREET, - - NEW YORK

The KREMENTZ LINE of SNAKE JEWELRY

IN
NECKLACES
AND
BRACELETS

MOUNTED WITH DIAMONDS, SAPPHIRES,
AMETHYST, TOPAZ, TURQUOISE MATRIX, ETC.
Bracelets Are Supplied With Solid 14-Kt. Gold Springs

NECKCHAINS of Any Length Desired



Bracelet, 2098.
Neckchain, 2140.

Necklace, 2122.

Bracelet, 2118.
Neckchain, 2129.

KREMENTZ & CO.

Manufacturers of

Fine Gold and Enamel Diamond Jewelry in 14-Kt. Only

MADE EXCLUSIVELY FOR FINE RETAIL JEWELRY TRADE

BRANCH
San Francisco Office
722 Shreve Bldg.

Factory and Main Office
NEWARK, N. J.

BRANCH
New York Office
1 Maiden Lane

DISTINCTIVE IDEAS IN SCARF PINS



AS A MAN'S "den" differs from all the other rooms in the house, so should his jewelry differ from all other jewelry—conforming to his individuality and personal taste. Such distinctiveness is embodied in the wide range of Scarf Pins made here.



PRICES: \$1.00 to \$300.00.

DURAND & CO.

49-51 FRANKLIN STREET
NEWARK, N. J.



OSMUN-PARKER MFG. CO.

MAKERS OF

Fine Pearl and Diamond Goods

338 Mulberry Street
NEWARK, N. J.

"THE BRACELET HOUSE"

GOLD BRACELETS of every kind
For WOMAN, MISS OR BABY

KENT & WOODLAND

16 John Street, New York

Factory: Newark, N. J. San Francisco: Julius A. Young

SNOW & WESTCOTT

21 MAIDEN LANE, NEW YORK



ESTABLISHED 1834

JAMES P. SNOW CHAS. E. WESTCOTT

MAKERS OF FINE GOLD

scarf pins, links,
brooches, handy-
pins, chatelaines,
fobs, etc., MADE IN

14 KARAT EXCLUSIVELY

John P. Bonnett & Son

Established 1879

*Electro-Metallur-
gists and Colorers
of Jewelry*

Plain, Fancy
Decorative and
Ornamental
Colorings of every
description : :

NORTH ATTLEBORO,
MASS.

B. OPPENHEIMER

BROKER IN

Rough and Cut Diamonds and
other Precious Stones

23 Holborn Viaduct, London, E. C. Eng.
and 29 Boulevard Leopold, - Antwerp.

Bankers:—"Union of London & Smith's
Bank," Holborn Circus Branch, London,
E. C., England.

C. R. HOWE
W. T. CARTER
W. T. GOUGH

ESTABLISHED 1841 BY A. CARTER

F. R. HORTON
F. W. STANBROUGH
H. L. FARROW

CARTER, HOWE & CO.

MANUFACTURERS OF

GOLD JEWELRY

Bags and Purses in Gold and Silver

9-11-13 Maiden Lane, New York

Factory, Newark, New Jersey

I. N. LEVINSON, President.

ESTABLISHED 1865

H. S. MORRIS, Sec. & Treas.

S. COTTLE COMPANY

Makers of High-Grade Gold and Silver Novelties

MESH BAGS
CARD CASES
PURSES
BUCKLES
VANITY CASES
CHATELAINES

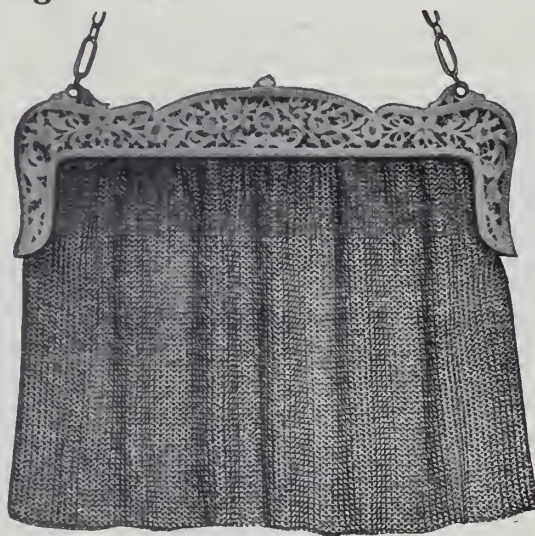

Our new line for Spring is now ready for inspection. Many new and artistic designs are shown. We wish to thank our many patrons for their past favors and hope for a continuance in the future.

PARIS
28 Rue D'Hauteville

31 EAST 17th STREET, NEW YORK

FRANFURT a/M.
Hanse-Haus, 9 Stifftstrasse

Even and graduated necklaces in Imitation Tourquoise, Jet, Amethysts and Pearls in stock.

Real Corals in All Shades.
Real Amber, Pearl and Coral Collars in all sizes and qualities, made up to order.

**GARNET BROOCHES,
CONCH SHELL CAMEOS.**
Selection packages sent to reliable parties only.

E. LECHLER,
Importer and Jobber of Jewelry,
67 Wabash Ave., Chicago, Ill.

SCARF PINS



Jade, Coral, Opal Matrix, Star-Sapphires, and other stones, in 14k. plain edge.

35 Maiden Lane,
New York.

Geo. O. Street & Sons.

ENOS RICHARDSON & Co.

MANUFACTURERS OF

14-K GOLD JEWELRY



- | | |
|------------|-------------|
| HANDY PINS | VEIL PINS |
| BARRETTES | BELT PINS |
| BROOCHES | HAT PINS |
| LINKS | SCARF PINS |
| FOBS | SAFETY PINS |

10-K AND 14-K NECK CHAINS AND LORGNETTE CHAINS

23 MAIDEN LANE, NEW YORK



The R. S. Cigar Cutter

In Sterling Silver, Plain and Engraved; and 14 k. Gold, Plain and Engraved, also Set with Diamonds.

A Novelty

Unlike all other cigar cutters, this one lies flat in the pocket—does not get out of order.

A Good Article



We Push It

Our advertising makes the customer want it; his friend sees it and he wants it. An endless chain of customers.

A Good Seller

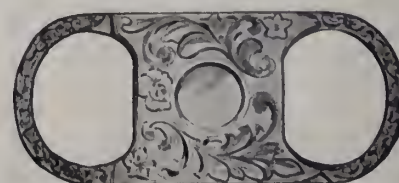

Trade supplied by

Enos Richardson & Co.
23 Maiden Lane, New York.

ACTUAL SIZE.

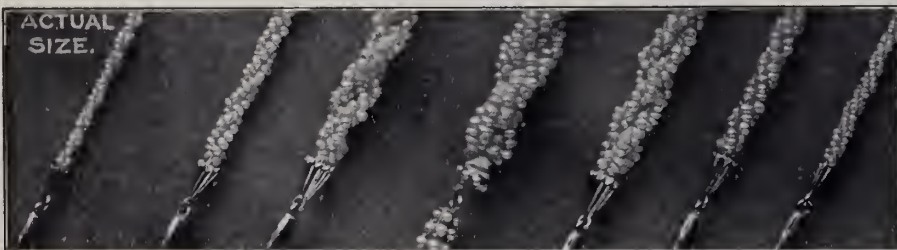

SEED-PEARL NECKLACES IN ALL SIZES.

OSMERS-DOUGHERTY CO.

MANUFACTURING JEWELERS

291-293 SEVENTH AVE., NEW YORK

Bet. 26th and 27th Sts. Telephone, 913 Madison.

DEALERS IN
BAROQUES, PEARLS and
FANCY STONES



DESIGNING
AND
SPECIAL ORDER WORK

HEINTZ BROTHERS



We Make the Largest Line of Solid Gold Set Rings in America for the Retail Trade

THE BEST
**SOLID
 GOLD
 CHAINS**

THE CHEAPEST

They stand the test of time and have done so for 56 years.

Supreme in
**QUALITY
 DESIGN
 FINISH
 WORKMANSHIP**



We Sell Direct. We Have No Salesmen. Eliminating all unnecessary expenses in making and selling enables us to sell at the lowest possible price. Send for catalogue.



ALOIS KOHN & CO.
16-18 Maiden Lane, New York
Makers of **Gold Chains** of every kind

THE CROHN PATENT SAFETY GUARD



For Scarf Pins Pins. The most adjustable one invented. Price, \$1.50 per doz. For sale by all wholesale jewelers and material houses. Sample by mail, 25c.; in 10k. gold, \$1.00; 14k., \$1.25. M. CROHN, Maker and Inventor. 48 and 60 Maiden Lane, N. Y.

Studs and Lace practical and only

J. H. GALAWAY P. H.
ENGRAVERS
CRESTS, MONOGRAMS and LETTERING
7 Maiden Lane, Rooms 44-45
Established over 35 years

Hill & Schmidt

71 NASSAU STREET

NEW YORK

Makers of Artistic 14 Kt. Jewelry



SPECIAL DESIGNS IN

La Vallieres - Handy Pins and Neck Chains

BUY GOODS WITH A TRADE-MARK



BANGLES
BROOCHES
BANGLE BRACELETS

HANDY PINS
TIE HOLDERS
VEIL PINS

A General Line of Fine Jewelry

BIPPART, GRISCOM & OSBORN

OFFICE AND FACTORY
Newark, N. J.

NEW YORK SALESROOM
1 West 34th St.

For Early Spring

When in other trades fine ribbon and belt fabrics are stirring, Jewelers should consider GOLD BUCKLES



Day, Clark & Co.

23 MAIDEN LANE
NEW YORK



TURQUOISE

Matrix - Turquoise

Best the World Produces

WE ARE prepared to furnish to the trade Matrix-Turquoise in all shapes and sizes.

Exquisite Color and Markings

We cut Turquoise to order

Mines at Mojave County, Arizona

THE ARIZONA
TURQUOISE MINES CO., Inc.

Cutting Works and Sales Office

171 Broadway, New York

SEND FOR CATALOG

Telephone 5728 Cortlandt

PLATINUM TIPS
EASILY SOLD

ARCH CROWN MTGS.

PLATINUM TIPS
EASILY SET



The gold tips always wear out first on the average mounting. Platinum outwears gold ten to one, so that platinum tips are practically impervious to wear. They blend with the diamond, enhancing its beauty. Platinum Tip Arch Crowns are the ideal gem settings. Your customers will appreciate being shown such a mounting, and are readily induced to buy.

ARCH CROWN MFG. CO. Send for New Price List Sole Makers and Patentees 26 Camp St., Newark, N. J.

THE WASHBURN

SECURITY **MAGIC NUT**
Automatic Holder for ear studs, scarf-pins, etc.
for all sizes of scarf-pin wire. Guaranteed.

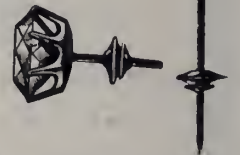

EAR WIRES
for unpierced ears.



SAFETY CATCH
For Brooches, etc.
Can be applied to any work where pin tongues are used.



Open. Closed. Open. Closed.
Descriptive Circular on Application.
Pearl Drilling and Adjusting a specialty.
Special Order Work and Repairing.
C. IRVING WASHBURN, 12-16 John St., N. Y.

GEMS AND PRECIOUS STONES

Cloth, Postpaid, \$1.00.

Published by The Jeweler's
Circular Publishing Co.

11 JOHN STREET

NEW YORK

SPRING TONICS

TONE up your Spring business with some of our INVIGORATORS



14 K., Pearl Set, \$4.50
A Leader in Brooch Values

New Things in Brooches, Links, Scarfs, Fobs, Buckles, Bracelets, Combs, Hat Pins, Veil Pins, Bags, Festoons, Etc.



2 Maiden Lane New York City



Monograms

INITIALS
AND
FOBS

Our
Specialties

Write for Catalogue,
Prices and Discounts.

CHICAGO
ART METAL
WORKS

63 Lake Street
CHICAGO, ILL.

Don't Worry About the Scarcity of Money

If you need any send us your surplus stock of Diamonds, Watches, Jewelry, Old Gold and Silver, and get our certified check by return mail. If amount is not satisfactory goods will be returned in same condition as received. Strictly confidential. Correspond or call. Telephone, 5202 John.

New York Jewelry Purchasing Co.
106 Fulton Street, New York

Allsopp & Allsopp

"Originators of the New Style"

OF

INEXPENSIVE DIAMOND JEWELRY

MOUNTED GOODS ONLY



"FOUR OF OUR LEADERS"

Our line this Winter is bigger and better than ever :: :: ::
A look at our stock will prove to your advantage :: :: ::

TOPPY.
A & A
TRADE-MARK

FACTORY AND MAIN OFFICE
18-20 COLUMBIA STREET
NEWARK, N. J.

The Allsopp Rings

The Up-to-Date
Line of **Signet and Set Rings**



In twenty years we have built up a business second to none in
RINGS EXCLUSIVELY

Allsopp

QUALITY,
DESIGN AND
WORKMANSHIP

Appeal to the Most Fastidious.
It Will Pay You to Examine
a Selection Package.



A ★
TRADE-MARK.

Allsopp Bros. Allsopp Building, Newark, N. J.

The Comb House

¶ We beg to call your attention to our fine line of new, Exclusive and Artistic Combs, both plain and mounted in Genuine and Imitation Tortoise Shell. ¶ We manufacture Combs exclusively in Genuine and Imitation Shell, both plain and mounted in 14kt., 10kt. Sterling and Gold Filled

SELECTION PACKAGES SENT TO RELIABLE JEWELERS

Wagner Comb Manufacturing Company

41 Union Square

HARTFORD BUILDING

New York

UNIQUE GEMS

I will send upon request to any reputable Jeweler or Manufacturer the most comprehensive sample line of ODD GEMS I think he has yet seen.

These stones are exclusively designed for rare conceits in the individual pieces of Handwrought Art Jewelry, such as command the highest prices owing to the rarity of their stone settings.

These comprise many rare examples of hitherto unexploited semi-precious, Ural, Ceylon and Native stones, such as AGATE-AMAZONITE, VIOLE T WAMPUMS, CAIRNGORMS, GEM-JASPER, LAMINATES, CEYLON SARDS, MADEIRA-STONES, OX-EYE, MOCHA-STONE, BI-COLORED TOURMALINES, ALL THE STAPLE QUARTZES AND MATRICES, AS WELL AS THE USUAL STAPLES.

I also show several fine single specimens adapted to the finest grade of **SPECIAL ORDER WORK** in RINGS, PENDANTS, SCARF PINS, Etc.

LOUIS J. DEACON, Atlantic City
New Jersey



GOLD PLATED Art Jewelry of every description, and the Schickerling patented Elk and Eagle lines. Fine Diamond Mountings.

¶ Makers of fashionable, popular price, ten and fourteen karat Solid Gold Jewelry. Card Holders for all Lodges, solid gold, sterling and plated. Artistic Novelties.

SCHICKERLING MFG. CO.

391-393 Mulberry Street, NEWARK, N. J.

CONRAD SCHICKERLING, Pres.

T. M. SCHROEDER, Treas.

**L. BONET,
CAMEO PORTRAITS,**



Importer of **Precious Stones,**

41 Union Square, NEW YORK.

Trade-Marks of the Jewelry and Kindred Trades.
Second Edition. Price, \$3.00. The Jewelers' Circular Publishing Co., 11 John St., New York.

The Bowden Rings

ARE COMPLETE IN VARIETY, CORRECT IN QUALITY AND PERFECT IN FINISH. WE MAKE EVERY VARIETY OF FINGER RINGS.

J. B. BOWDEN & CO.,

1 Maiden Lane.

NEW YORK.



BYRON & VAIL CO.

Successors to { CHAS. B. BYRON & CO.
and
W. W. HAYDEN CO.

291 and 293 Seventh Avenue, New York City

MANUFACTURERS OF

High Grade 14K. Gold and Sterling Silver Novelties

The most complete High Grade Novelty Line in the market.
Estimates cheerfully given and samples submitted on approval.

Correspondence solicited.



102 Fulton St., NEW YORK

C. CORNEHLSSEN

Successor to Bergstein & Son

14 K. GOLD AND PEARL JEWELRY

Necklaces, La Vallieres, Brooches, Handy and Scarf Pins, set with semi-precious stones in attractive combinations

LOCKETS ONLY

Registered



U. S. Pat. Office



Pat. Applied for
NUMBER
8448

One of our many new designs for Spring Trade

WIGHTMAN & HOUGH CO.

NEW YORK OFFICE
3 Maiden Lane

Main Office and Factory } 7 Beverly St.
PROVIDENCE, R. I.

S. F. Myers & Co.
WHOLESALE JEWELERS
47-49 Maiden Lane
New York

Quality in our goods means something besides fancy prices.

For the trade only — our new, big catalogue, with 100,000 items, sent free.

JEWELERS' SHOW CASES.

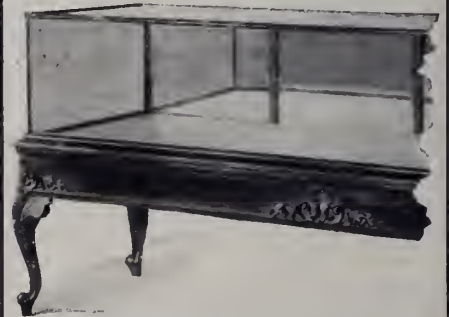

Our Small ROSEWOOD MOULDING STEEL LINED CASE. We Challenge the World to Produce a Better Case.

F. C. JORGESON & CO.
11-17 N. ANN ST., CHICAGO

Makers of all Kinds of
JEWELERS' FIXTURES

Write for Illustrated Circular
Our Motto: The Best of Everything

The Locket House

10 K. 14 K.



A GUARANTEE
AND QUALITY
OF SATISFACTION



38TH Year

Rothschild Bros. & Co.

51 and 53 Maiden Lane, New York

PENDANTS; Half Pearl, Whole Pearl, Knife-Edge
HANDY PINS; Pearls and Semi-Precious Stones

INFORMATION

The right kind of information—the kind that will help you in your daily business work—information that will save you many a dollar is found in our Yearly

GREAT
American Jewelry Catalogue

ASK FOR IT

THE OSKAMP NOLTING CO.

Mammoth Wholesale Jewelers
413-415-417 Elm Street CINCINNATI, OHIO

SEND YOUR SWEEPS to the
Cincinnati Gold & Silver Refining Co.
REFINERS, ASSAYERS AND SMELTERS
Office, 523 Elm Street; Works, 2257 Eastern Avenue; CINCINNATI, OHIO
Highest Price Paid for Gold, Silver and Platinum Platinum and Gold Filings Retined by the Russian Method

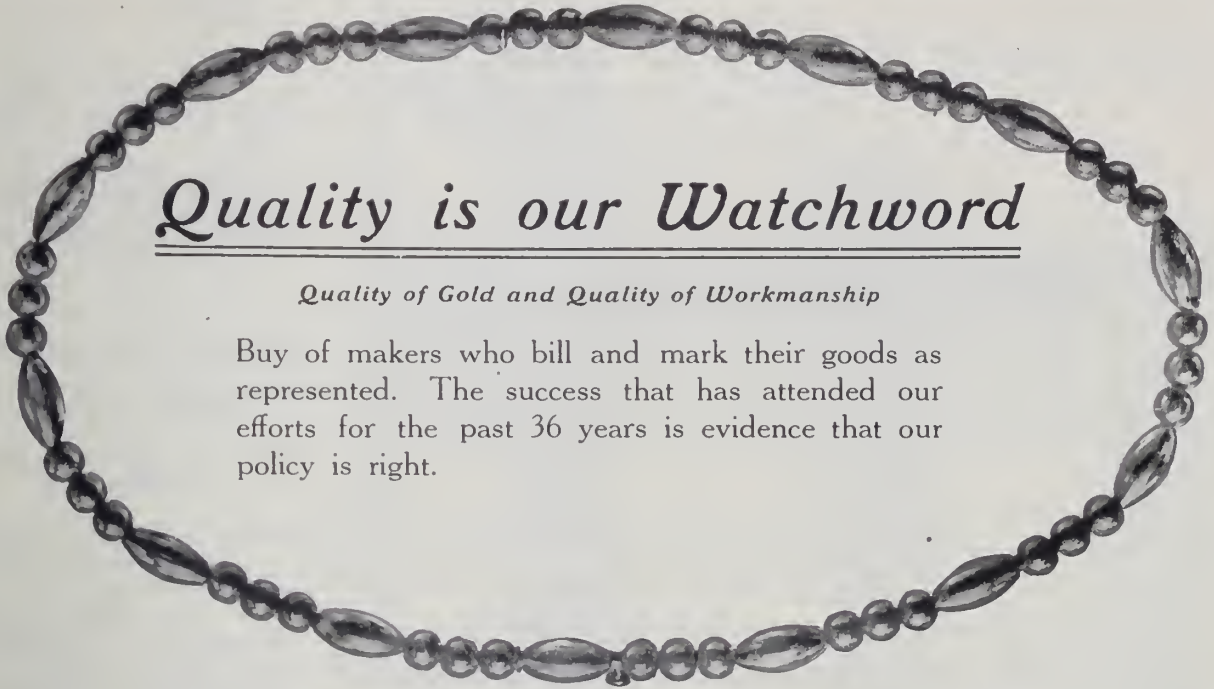

Quality is our Watchword

Quality of Gold and Quality of Workmanship

Buy of makers who bill and mark their goods as represented. The success that has attended our efforts for the past 36 years is evidence that our policy is right.



Trade-Mark



Bead Neck Chains

LINK BUTTONS, GOLD FOBS, RIBBON FOBS,
BRACELETS, GUARD CHAINS, NECK
CHAINS, VEST CHAINS

C. SYDNEY SMITH & CO.

Established 1870

Manufacturers of GOLD CHAIN AND JEWELRY

9-11-13 Maiden Lane, NEW YORK

Factory, Providence, R. I.

Sterling Silver

Illustrations Actual Size

The Scarab or Sacred Beetle

A talisman of good fortune. The all-powerful symbol of good of the ancient Egyptian.

HAT PINS

Japanese Coral, Jade, Malachite, Lapis, Amethyst, Chinese Jade



No. 24113

Also made in Fobs, Scarf Pins, Link Buttons, Brooches, Finger Rings, etc. We originated Swastika which swept the country like wild-fire. The public is eager for good luck charms which have a history, signify something, and in the Scarab or Sacred Beetle we predict another unqualified success. The Scarab is of stone, in the form of a beetle, on oval base. Don't delay in placing order.

PAYE & BAKER MFG. CO. New York Office, 9-11-13 Maiden Lane
NORTH ATTLEBORO, MASS. (SAMPLES ONLY)

Frank M. Whiting & Co.

Silversmiths



North Attleboro, Mass.

320 Fifth Avenue, New York

WM. SMITH & CO.

OFFICE:

Established 1854.



MANUFACTORY:

9-13 Maiden Lane, New York

61 Peck St., Providence, R. I.

Manufacturers of **GOLD AND SILVER CHAINS**
GOLD, SILVER AND PLATED CHAIN TRIMMINGS

Also **GOLD AND SILVER**
KEY CHAINS AND
BRACELETS

-  1. Snap complete.
-  2. Outside of snap.
-  3. Inside of snap.

The E. P. H. Patent

NON-PULL-OUT Neck Chain Snap

is a patented snap that insures the wearer against loss of

CHAIN or CHARM

for it positively will not pull out

Made in 10 and 14 Karat Gold and In Gold Filled.

Can be had of the following Wholesale Selling Agents:

Messrs. W. Green & Co.,
81 Nassau St., New York

- M. Sickles & Sons, Philadelphia
- E. A. Cowan & Co., Boston
- E. & J. Swigart, Cincinnati
- Swartchild & Co., Chicago
- Nordman Brothers, San Francisco
- Leonard Krower, New Orleans
- A. Walker Co., Providence, R. I.
- Bauman-Massa Jewelry Co., St. Louis
- H. S. Melskey Co., Lancaster, Pa.
- The Edw. Lehman Jewelry Co., Denver, Col.

PRICES.

- 14 Karat—Small, \$7 per doz. net
- Large, \$7.50 per doz. net
- 10 Karat—Small, \$6 per doz. net
- Large, \$6.50 per doz. net
- Gold Filled—Small, \$2 per doz. net
- Large, \$2.25 per doz. net

Learn Watchmaking

Refined, profitable labor. Competent men always in demand. We teach it thoroughly in as many months as it formerly took years. Does away with tedious apprenticeship. Money earned while studying. Positions secured. Easy terms. Send for catalogue. Address

St. Louis Watchmaking School, St. Louis, Mo.

CRUCIBLES.



Jewelers' Supplies,
Etc.

Established 1850.

J. & H. BERGE,
95 John Street,
NEW YORK.



Gems and Precious Stones
Cloth, Postpaid, \$1.00. Published by the Jew-
elers' Circular Pub. Co., 11 John St., New York

Do not have New Cluster Heads made

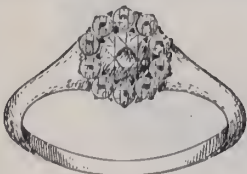

We repoint Clusters, Marquise, Princess and other fancy rings; we make them like new at very reasonable prices.

One trial will convince you that we do exactly what we claim. We make a specialty of all kinds of repairing. Write for price list—it will pay you.



ARONSON & SPIEGEL, 78 Nassau St., New York

As received from Customer

As delivered to Customer

Insure Your Life

L.A. Miller

Special Agent of the

Equitable Life Assurance Society

will show to any who may be interested Sample Annual dividend policies on the

LIFE, LIMITED PAYMENT, ENDOWMENT, and TERM PLAN

ADDRESS

L.A. Miller

Special Agent

180 Broadway, N. Y.

It will pay you to wait for our

New Spring Catalogue

New designs, lowest prices, highest qualities

LOUIS RAUCH

WHOLESALE JEWELER

530 Walnut St., Cincinnati, O.

CASTINGS Gold, Silver, Bronze, Brass, German Silver, Copper and Iron.
L.D. TEL. 2072 L. Supply Jewelers, Silversmiths, Die-makers, Mould-makers, etc. Bronze Forces, Hard Bronze and Iron Shells for Die-cutting Machines. Cast Iron Hub for sinking in Steel Dies. Chandelier, Undercut Work, Statuary.
AUGUST GRIFFOUL 313 HALSEY STREET NEWARK, N. J.

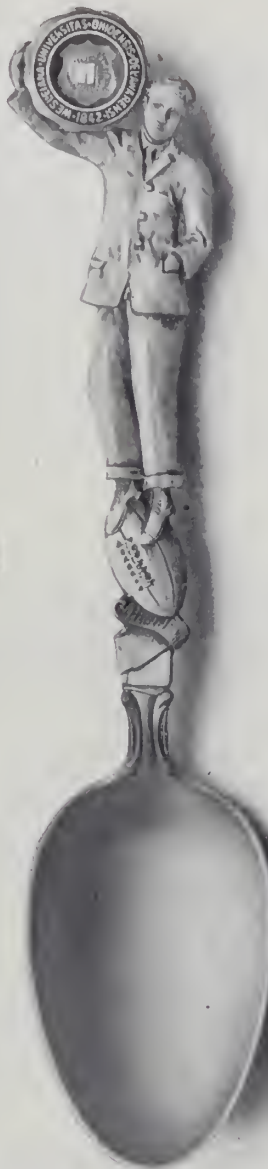

WE desire to call the trade's attention to our latest creation in Souvenir Spoons for the College Trade—

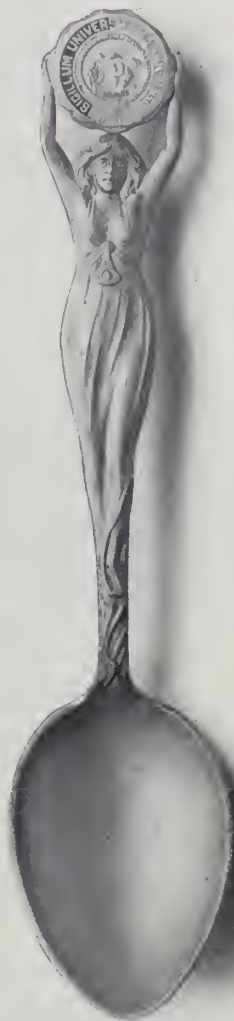

"The Whole Family"



These articles have proven ready sellers, so that every jeweler who caters for college trade should not be without them. Write to us for samples, prices and terms.

THE KINNEY CO. Main Office and Factory, 14 Blount St. PROVIDENCE, R. I.

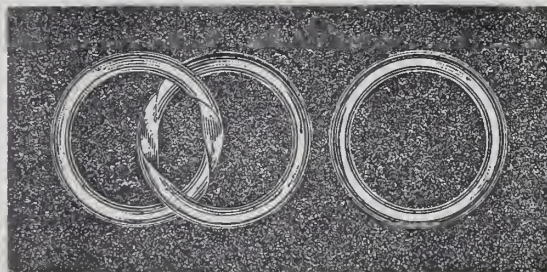

WE MAKE

The Alliance Ring

The graceful style of the Alliance Ring is rapidly supplanting the use of the old style wedding ring. The joints are invisible, and whenever engraving is desired it is done in the inside surface. Can be easily separated by inserting a pin in inside pin-hole.

14 karat, 3 dwts., each, \$1.25 per dwt. ; in dozen lots, \$1.15 per dwt., net.
18 karat, 3 dwts., \$1.40 per dwt. ; in dozen lots, \$1.30 per dwt., net.

MADE ONLY BY

LEONARD KROWER, Manufacturing Jeweler

536-538 Canal Street

New Orleans, La.

Lederermak Locketets

ALWAYS BUY
“VERIBEST”
 LIFE TIME GUARANTEED PERMANENT SATISFACTION



Champagne Finish — Goodasgold



Sold Only Through **VERIBEST** Jobbers Everywhere

“FAMOUS SINCE 1870”

Manufactured by
S. & B. L. ★ CO.

Providence, R. I.: 100 Stewart St. New York City: 9-11-13 Maiden Lane Chicago, Ill.: 131 Wabash Ave.

THE SIMPLEX RING BENDER



Why waste your time and money by old-fashioned methods? The Simplex Ring Bender works on a new principle. It will bend any ring better and ten times faster than any other way, and without marring the most delicate design. Saves chasing. A boy can operate it. Simple, strong and durable. Fully guaranteed. Send for circular to-day.

THE BAILEY-FILSON CO.
 244 W. 23d St. NEW YORK



THE ARCHIBALD-KLEMENT LINE OF

SILVER DEPOSIT WHISKY BOTTLES

Distinguishable for their dignity of design and excellence of finish. Made in full quart size, four designs—Narrow Strap, Broad Strap, Rye, Thistle. Shield space for monogram, sterling silver corkscrew tops. Highball and whisky glasses to match each design.

No. 58

Full line of the foregoing, and any other desired pieces in the A-K Silver Deposit Ware, sent on approval.

ARCHIBALD - KLEMENT CO.
 Sample Rooms: 341-347 Fifth Ave., N.Y.
 Factory: NEWARK, N. J.

Trade Marks of the Jewelry and Kindred Trades. Second Edition. Price, \$3.00. The Jewelers' Circular Publishing Co.

M. J. AVERBECK

Manufacturer and Importer
10-12 Maiden Lane - New York

NEW
FESTOON NECKS

NEW
VANITY PURSES

NEW
MESH BAGS

NEW
VEIL PINS

NEW
SASH PINS

NEW
BELT BUCKLES

NEW
COMBS

NEW
BRACELETS

NEW
BROOCHES

NEW
HAT PINS

NEW
SCARF PINS

NEW
WAIST SETS

NEW
DUMBBELL LINKS

NEW
**NOVELTIES IN
GOLD**

**GOLD-FILLED
STERLING SILVER**

M. J. AVERBECK

Manufacturer and Importer
10-12 Maiden Lane, - New York

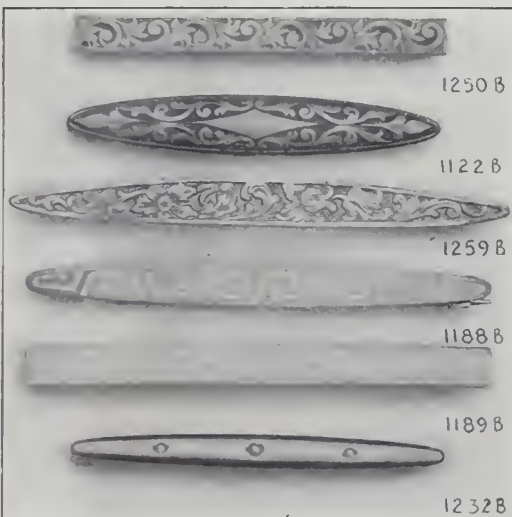
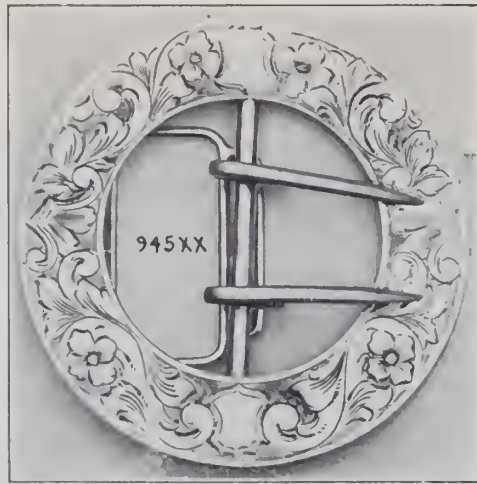

M. J. AVERBECK

Manufacturer and Importer
10-12 Maiden Lane - New York

*WE ARE SPLENDIDLY
EQUIPPED FOR THE
SPRING CAMPAIGN OF
1908.*

*OUR STOCKS ARE COM-
PLETE, SELECTED
WITH THE UTMOST
CARE IN OUR HOME
AND FOREIGN MAR-
KETS.*

*WE NOW HAVE READY
A LINE OF SPRING
SELLERS. WE ARE THE
"LEADING HOUSE IN
THE JEWELRY BUSI-
NESS."*

*EVERY POPULAR, DE-
SIRABLE THING FOR
THE SPRING OF 1908.*

*"ALL FRESH, NEW
GOODS, PROMPT DE-
LIVERIES AND SATIS-
FACTORY PRICES" OUR
MOTTO.*

M. J. AVERBECK

Manufacturer and Importer
10-12 Maiden Lane, - New York



The Thimble House.



No. 149.

Thimbles are not a side line with us—They are our main business. We study Thimbles, our designers study thimbles, our workmen study thimbles—The result is the finest and largest line of Thimbles on the Market.



No. 136.

KETCHAM & McDOUGALL,

Manufacturers,

37 @ 39 Maiden Lane, New York.

Send for Catalogue.

Established 1839.

ALSO MAKERS OF THE NEW AUTOMATIC EYE-GLASS HOLDERS

C. VAN SCHOOR

MANUFACTURING JEWELER
AND REPAIRER

Best Workmanship. Lowest Prices. Jewelry Findings and Supplies. Importer of Jobbing Stones. Our findings are made of first quality, seamless stock, in all grades, direct from manufacturer to retailer. Our terms are cash. Give us a trial on repair work or send for booklet. Mail orders and repair work filled same day as received.

2041 W. 45th St., Cleveland, Ohio

Trade-Marks

of the Jewelry and Kindred Trades. Second Edition. Price, **\$3.00.** The Jewelers' Circular Publishing Co., 11 John Street, New York.



64 YEARS

of honest business methods,
together with goods of quality,
have branded us

"The Old Reliable."

SEE OUR SPRING LINE

THE
CLEMENS OSKAMP CO.
CINCINNATI, O.

MANUFACTURER OF HIGH-GRADE DIAMOND MOUNTINGS

Prompt Attention
Given to Special
Order Work :: ::



Estimates and
Designs Submitted :: :: :: ::

Patented October 24, 1906.

DIAMONDS RECUT AND REPAIRED

JULIUS WODISKA, 40 John St., New York

PRACTICAL COURSE IN ADJUSTING.
All Jobbers or Jewelers' Circular Publishing Co.
Published Price, \$2.50.
Special Reduced Price, \$1.50, Postpaid.



The Kind that Sell



The goods that make the most profitable sellers are the ones whose quality you can depend upon. Our "F. & B." trade-mark is a symbol of the best, combined with attractiveness. We have some of the most beautiful designs in Locketts and Charms, Brooches and Bracelets, Hat, Scarf and Veil-Pins, as well as Links and Festoon Necks. Remember, too, our fine line of Sterling Silver, consisting of many new articles in Toilet and Manicure Goods, Candle Holders, Frames and Novelties.

Illustrations Full Size

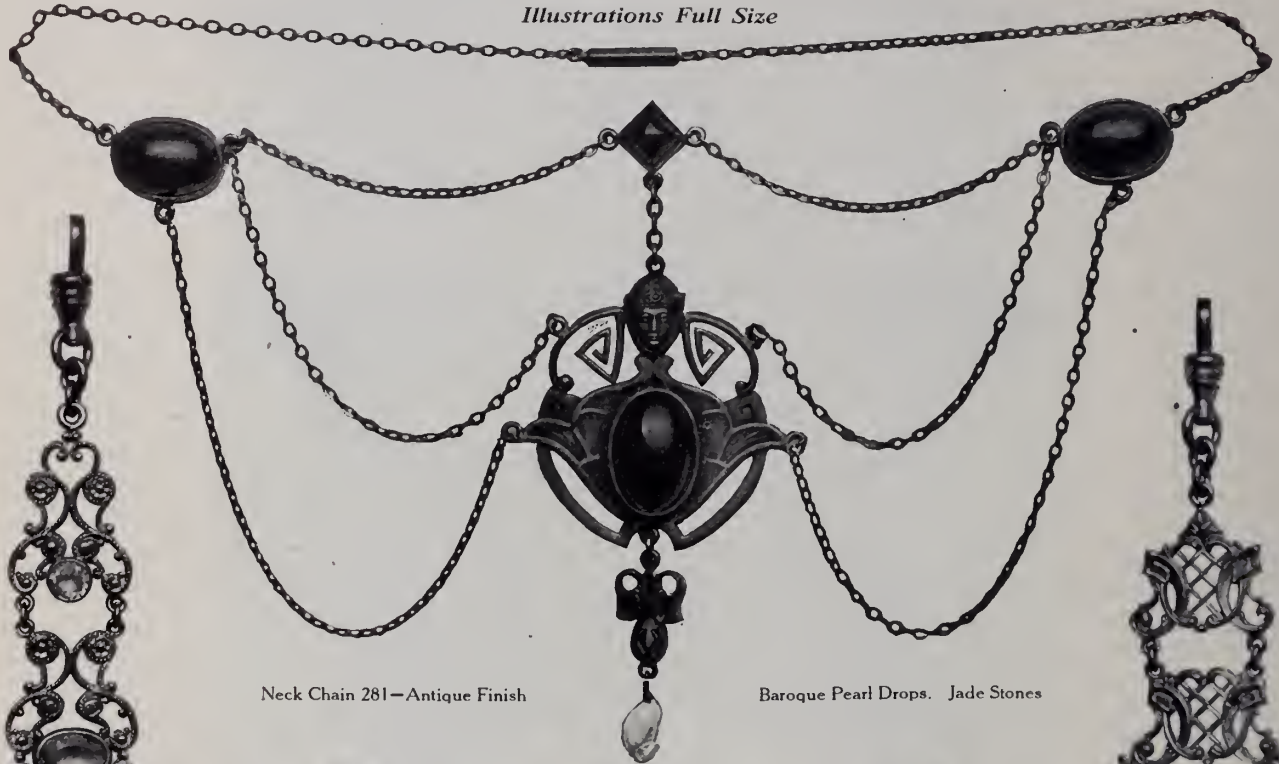

Neck Chain 281—Antique Finish

Baroque Pearl Drops. Jade Stones



Fob Chain 1583
Rose. Signet Charm
Stones set as ordered
1603—Old English



Fob Chain
1586—Rose. Signet Charm
1604—O. E.



Locket 2989—Rose Brilliants
2988— " No Stones



Locket 3009—Rose
3011—Rose Brilliants



Locket 2993—Old English
Engraved



Hat Pin 867
Old English
Hand Chased



Scarf Pin, O. E.
880—Real Amazonite Stone
882—Imitation
Stones set as ordered



Link 756 Rose
Raised Head



Scarf Pin 883
O.E., Stones set
as ordered



Hat Pin 873
Old English
Hand Chased



Locket 3006—Rose
3008—Rose Brilliants



Locket 3010—Rose
3012—Rose Brilliants

Theodore W. Foster & Bro. Co.

Manufacturing Jewelers and Silversmiths

100 RICHMOND ST., PROVIDENCE, R. I.

NEW YORK: 13 Maiden Lane

CHICAGO: Heyworth Bldg.

CANADA: Kingston, Ontario

Essential Principles to be Considered in Judging Applied Design

A WELL-KNOWN New York educationalist, Dr. James B. Haney, recently delivered an instructive address, setting forth some of the principles of applied design. The immediate purpose of the lecture was to assist teachers in guiding their pupils in the study of design. No doubt it is a far cry from the desk of the teacher to the counter of the jeweler. Yet every jeweler who conducts an art department is in some degree an art student. Not that he necessarily looks forward to making designs himself, but he is constantly called upon to pass judgment upon them, and he must have some basis for criticism. Handling art products, it is well for us to have some conception of underlying principles, so that as purchasers we may know where to criticize, and as vendors we may appropriately emphasize points of excellence. It is not the purpose here to give anything like a résumé of Dr. Haney's lecture. The address has, however, suggested some of those informal comments in which THE COMMENTATOR has a habit of indulging in a somewhat free and untrammelled fashion.

It may seem disappointing to begin with a negative, and yet one fact has to be admitted at the outset: there is no rule for beauty, there is no formula for it. If there were we might all be artists. If there were a rule and all the artists followed it, we might assume they would all paint alike. The artist has a faculty capable of perceiving beauty, a sort of sixth sense, and by practice and experience he is enabled to produce it in his own way. The more he works by rule the less he is an artist.

Have you ever seen a fine printer experiment with color combinations? He tries different tones on different shades of paper until at length his inner consciousness tells him he has it right. He needs the capacity for taking pains, though facility grows with experience. One's ideas of beauty have to be "tried out." What we think would look well often proves disappointing when sketched out. Rules, however, may point a direction, even if they cannot guarantee a result. Negatives have their place, too. Some advance has been made when one knows what to avoid, and it is as much the function of criticism to detect flaws as to appreciate virtues.

Design is necessarily limited in its expression. It is not a picture; it is rather a pattern. Conventionality is a condition precedent. Fruit, flowers, leaves, etc., all must be conventionalized. Too severe regularity, however, savors of mathematics, as if design were simply a matter of arith-

metic. A designer with a bent towards individuality might well chafe against the restrictions of too precise regularity. A notably successful artist of the writer's acquaintance, has a way of complying with the spirit of conventionality, but not with the letter. He allows himself some play of fancy, takes little flights which add distinctiveness to his work.

The weakness of conventionality is that it is apt to become monotonous. To add a pleasing impression of variety requires positive skill. Suppose the designer to be drawing something in the general form of a shield. Convention would dictate that the opposite sides, right and left, should exactly correspond. The writer has seen slight variations introduced into these sides, just enough to avoid monotony without marring the general effect of regularity. Still the experiment is risky, unless in competent hands. Safety lies in regularity. As already intimated, conventionality is mathematical at heart; it is mainly a matter of proportion, division and multiplication.

It is true that both picture and design are often to be found in the same decoration. On a vase, for example, the ornamentation frequently provides a central panel for the express purpose of including a picture. Here the object is embellished with the portrait of some famous court beauty, or the reproduction of some brilliant historic scene. Thus in a sense the picture becomes part of the design; but the design is no part of the picture. The latter has an identity of its own, and is complete in itself. The design serves as a frame. Another picture could be substituted without affecting the design.

There are instances, however, where the line of demarcation between design and picture is not so easily distinguished. The more skilfully the artist veils his conventionality, the more nearly will the decoration approach the standard of a picture. Sometimes the terms are used interchangeably, and what is really a picture is called a design or pattern. Suppose the object to be a lamp shade decorated with a representation of roses with bud and leaf as seen in nature. We would speak of it as a "rose pattern," though really a picture. Treatment of this nature is appropriate in plain, undivided surfaces, but if the form of the lamp shade were such as to divide it into uniform panels, then the very geometry of the object would suggest conventional design rather than pictorial treatment.

This brings us to the fundamental principle that the form should suggest the de-

sign. The artist gets his first hint from the shape and contour of the object. The principle can be pushed still further. If it is true that the form should suggest the design, it is equally true that the use should suggest the form. In the preparation of an object it is evident that there are two distinct phases: first, the evolution of form; second, the application of decoration. Manifestly there should be harmony between form and use, if the results are not to be anomalous.

Suppose that in shaping a loving cup some erratic designer should get a freakish whim into his head to make the rim curve inward instead of outward to ward the lip. He might argue that the loving cup is a traditional product rarely used for its original purpose, and that the conformation of the rim is no longer important. You would tell him that the idea of good comrades drinking together, pledging one another, is the very soul of the loving cup, and that the form must preserve the idea. Again the harsh surfaces and sharp angles which might be appropriate in a metal match box would hardly serve for the handle of a paper cutter to be held in a lady's hand. On the last analysis, therefore, design receives its primary impulse from use.

Another point to note in connection with design is that all parts are not equally important. The artist must know where to emphasize and where to conceal. As a general rule, it may be stated that the upper sections should command the most attention, the interest diminishing toward the base. One can take a hint from tree and flower which burst into blossom and foliage at the top, while the roots are hidden under ground. Manifestly the base or pedestal supporting an object is of less account artistically than the object itself. Over-elaboration of the former would diminish the effect of the latter. Of course, the object must have support and balance; it must have a foundation of sufficient strength, but the skilful designer is careful to render such features as unobtrusive as possible. It is a canon of designing to diminish what are called "points of force."

It may hardly be necessary to add that the design should be adapted to the nature of the material. Obviously, it would be absurd to cover a fine piece of porcelain with an opaque decoration wholly concealing the nature of the ware. As soon think of painting a genuine bronze. The reader might be forgiven for doubting if that very thing had ever been done, but THE COMMENTATOR could tell how a bronze was thus "improved" by an old lady, whose eyesight was not keen, and whose artistic judgment was even less acute.

THE COMMENTATOR.



No. 2428

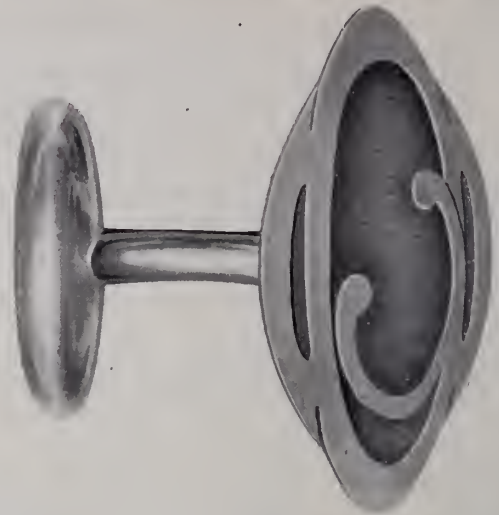

No. 2425

This year is not the time to sit down and float with the tide. To succeed—to get there—one must swim against the current. Unusual efforts must be put forth to accomplish satisfactory results.

From a gold jewelry manufacturer's standpoint this means more new goods at right prices than ever before. That's our plan.

The above illustrations are patterns from a fine new line of 14 K. stiff bar buttons that are just seeing the light of day, which for price, pattern and construction are unequaled in the market.

This line our travelers are now showing, or if they cannot reach you promptly, to progressive retail jewelers we will be pleased to send some on memorandum.

Are you going to float with the tide or swim against it?

LARTER & SONS

Trade-Mark



21-23 Maiden Lane

NEW YORK CITY

Registered in U. S. Patent Office

The Municipal Plate of the Cities of Europe.

By CHARLES A. BRASSLER.

ALTHOUGH we are credited with being one of the richest nations in the world, in one respect the large cities of the United States are appallingly poor, and that is in municipal plate. Even such insignia of office as the Mayor's chain seem to be an unknown quantity here. While excessive ostentation and pomp would, of course, be out of place in a republic, there is no reason why our prominent cities should not gradually acquire municipal treasures, especially if they are donated by patriotic citizens. The silversmith certainly would be greatly

municipal possessions in this line in Europe now constitute an important material for a study of the productions in the domain of gold and silver smithing of former centuries. The custom of presenting such pieces to the city is an old one, for when the Church had ceased to be practically the only patron of the goldsmith the rich burghers became almost as good customers as the princely houses.

In few countries, perhaps, has the custom of making these gifts been so enthusiastically followed as in Germany. Future generations will note two periods of especial prosperity for German municipalities. The first was in the 15th and 16th centuries, the

At the period when the cities of Germany were in the first flush of their prosperity each one possessed its own municipal silver, which adorned the tables when the noble councillors entertained some neighboring prince, or perhaps the Emperor himself, at a banquet in the council house. The storms which swept over Germany in the 17th century wrought havoc everywhere with these treasures. Part of them became the plunder of foreign soldiers, and found their way into France, Austria or Sweden; others were melted down to pay the war levies. When peace and prosperity returned, scarcely one of the cities had kept much of its municipal treasure, and some



GOBLET OWNED BY AIX-LA-CHAPELLE.



SALVER OWNED BY AIX-LA-CHAPELLE.

benefited, and artistic endeavor promoted to no small extent.

Probably the nation has been too young and too busy to think of such a thing heretofore, but the time will surely come when our æsthetic feeling will have sufficiently developed for rich men to follow the European custom of donating handsome pieces of silver work to the city, which will be preserved to commemorate the name of the donor, and convey to future generations an idea of the artistic capabilities and styles of our period, just as the remains of the

second began with the middle of the 19th century, and has not yet closed.

It may truthfully be said that some of the finest creations of German gold and silver smithing are in municipal plate, and that orders for such works are always very anxiously sought, creating much rivalry among the competing jewelers, since the honor and even the monetary return derived therefrom are usually greater than from ordinary commissions.

did not possess any precious metal work whatever. Of the famous Lüneburg municipal plate, amounting to 300 pieces in 1600, only 37 pieces remain to-day, of which the Germanic Museum at Harvard has some reproductions. In the last decade or so the municipalities have entered upon a generous rivalry in point of reproducing and restoring the former possessions and acquiring new treasures.

The beginning was made with the Burgo-

master's chain, worn around the neck as a part of the insignia of office; these became works of art. The next step was the "Kaiserpokal," or the goblet in which, according to the old German custom, the Council offered to the Emperor the "*Willkommentrunk*," or pledge of welcome. In many German cities it is the custom to keep a book mounted in gold, in which distinguished guests write some sentiment, or at least their names. The use of this requires an inkstand, and to the "golden book" was soon joined the costly inkstand, usually of gold. The latest acquisitions have been

Three highly interesting pieces were recently turned out by Bernhard Witte, the well-known goldsmith of Aix-la-Chapelle, on the order of the "Bürgerschaft," to form part of their municipal plate, namely, an inkstand, a salver and a tall goblet. The latter rests upon four figures, which typify the industries and arts of the city; they are the architects, the goldsmiths, the cloth makers and the pin makers. Above these the stem narrows to a circumference easily grasped by the hand, and then widens into the cup. Monotonous surfaces are avoided, bosses and foliage taking their place. On the upper edge is the inscription:

*Aachens Gäste zu ehren,
Den Ruhm der Stadt zu mehren,
Schuf mich voll Kunst
Treuer Bürger Gunst.*

of dedicating his cathedral to the Virgin. The broad rim of the salver is ornamented with a pattern of leaves and bosses, repeated 16 times, but so skilfully arranged that there is no feeling of monotony. At the outer edge it forms 16 semicircles, and here are brought in the coats-of-arms of Cologne, Frankfort-on-the-Main, Mayence, Speyer, Nuremberg, Augsburg, Strasburg and Dortmund.

The inkstand is a representation of the legend which tells that the devil, outwitted by the builder of the Aix-la-Chapelle cathedral, tried to bury the city under a sand hill in revenge. Confused by fog, he lost his way, and, directed by an old woman, poured out all the sand which he had laboriously collected outside of the city walls. The goldsmith has placed the



DOUBLE CUP IN LÜNEBURG TREASURE.

silver epergues and table services, which have offered to the talents of German goldsmiths the richest opportunities. In former issues of THE CIRCULAR-WEEKLY many fine specimens made for the municipalities of Hamburg, Frankfort, Cologne, etc., have been described and illustrated. Wealthy citizens have vied with each other in making these gifts ever more splendid and perfect. One of the most beautiful collections, perhaps, is owned by the city of Aix-la-Chapelle.



INKSTAND OWNED BY AIX-LA-CHAPELLE.

The cover begins with a crown of loose foliage, from which rises a pedestal decorated with bosses and leaves, and supporting the figure of a knight, bearing the standard of Aix-la-Chapelle. A number of different coats-of-arms form part of the decoration. At the foot are figures representing the city and the chapter, with the figure of the Burgomaster, Herr Chorus, who built the council house and the choir of the cathedral, and that of the present Burgomaster, Herr Veltman. Just below the figure of the knight is the Hohenzollern coat-of-arms.

The goblet is to be handed to the honored guest of the municipality on the gala salver, 42 centimeters in diameter. In the center of this is the most beautiful of the old city seals, representing Charlemagne in the act

Evil One within a ring of masonry, broken by reproductions of the Pont Gate, the Marchier Gate, the Langer Thurm (Long Tower) and the Marienthurm (Mary's Tower). The whole inkstand rests upon four monsters, which harmonize well with the Satanic figure above.

The design shows humor, and the artist has proved his capacity for secular work to be as great as that which he has exhibited in ecclesiastical pieces. With the aid of able assistants, Messrs. Essenwein, Frenzen and Buchkremer and others, including the art antiquary Bock, he has accomplished such excellent work that we are justified in expecting still more from him. Mr. Witte also executed the fine aluminum-bronze door that the City Hall of Aix-la-

Chapelle can boast, with beautiful relief pictures and mountings.

Much beautiful municipal plate, antique and modern, was shown at the German Cities' Exhibition in Dresden in 1903, and also at the St. Louis World's Fair, at which latter, for instance, the splendid collection of replicas of antique specimens was displayed that Germany, after the close of the Exposition, presented to the Germanic Museum at Harvard University.

At the Dresden exhibition could be seen, outside of the afore-mentioned pieces from Aix-la-Chapelle, the golden book and inkstand of the cities of Dortmund, Hildesheim, Halle, Göttingen, Cologne, etc., which attracted widespread attention on account of their beautiful execution.

Among the epergnes shown, that of the rich and art-loving city of Cologne was most universally admired. It is called "Father Rhine," and was fully described and illustrated in a former issue. All who saw it were full of praise for the maker (Hermeling) and appreciation for the donors. Of the well-known Aix-la-Chapelle epergne or table center by Amberg only a photograph was shown, but Dortmund sent handsome pieces from her municipal treasures in the originals. Very fine specimens of the goldsmith's art were also the exhibits representing gifts of German cities to meritorious citizens, and likewise the addresses accompanying them, and the receptacles for the latter; and last, not least, the many seals and medals of the various cities.

A fine specimen of municipal gifts is the handsome punch bowl which the city of Düsseldorf recently had made, to be given away later to the Düsseldorf Artists' Club "Malkasten" for its 50th anniversary. This superb piece is of considerable size, holding as much as 60 quarts. It is of imposing and yet pleasing appearance. The round body, slightly flattened above, is embellished with smooth raised ornaments. Around the middle runs the dedication in prominent letters. The neat soldering on of these letters shows with what care the work has been executed. The rim of the lid is decorated with a grape branch around which a band is coiled. In place of a foot, four different dragons serve as supports of the bowl. Their physiognomies betray the fact that they have already imbibed a little too freely. On the cover appears a device also in prominent characters. The handle of the lid consists of a strong heraldic lion with the anchor, the municipal coat-of-arms of Düsseldorf, which, at the same time, constitute a handsome termination of the whole structure. The raised portions of the punch bowl are in matt silver, the ground is in matt gold.

The design was furnished by Prof. G. Oeder, and is perfectly original. No similar one can be found in any book of designs. C. A. Beumers, the well-known silversmith, executed the work with great skill, the different parts all bearing eloquent testimony to his perfect mastery of every branch of his craft. The large and difficult task had to be completed in the short period of three months.

No civilized land has ever been so thoroughly plundered as was Germany during the Thirty Years' War. Enemies and

friends alike dragged away everything movable which seemed to be of any value. The Swedes, especially, excelled themselves in this respect. Before the Thirty Years' War Sweden was the poorest land in Europe as regarded precious metals, or treasures of industrial art and science. In the years from 1630 to 1648 the libraries of the Swedish universities were filled with German books, and the seats of Swedish noblemen were adorned with treasures of German goldsmiths' work. A large and splendid book was published not long ago in Sweden, giving reproductions of some beautiful pieces of precious metal work which are in the Kremlin in Moscow, and of a large number of which the New York Metropolitan Museum possesses excellent reproductions or replicas. These were gifts of the King of Sweden, in later

days, to the Czar, almost exclusively of German handiwork, and without exception stolen from Germany. A few fortified towns and a few families, favored by fortune, were enabled to keep their treasures, and these rarities are now greatly valued and admired.

The greater part of the Lüneburg silver treasure is now in the Berlin "Kunstgewerbemuseum." As we have described this collection before, we only illustrate a double cup. Nuremberg had two silver centerpieces, made by Wenzel Jamnitzer; one was melted down in the days of the French invasion, the other sold for the enormous sum of 600,000 marks (\$150,000) to the Rothschilds, in Frankfort, and only a reproduction remains. The famous "Kaiserpokal" of Osnabrück barely escaped the same fate as the latter. The bargain had



GREAT PUNCH BOWL OF DÜSSELDORF.

already been made when the sale was forbidden by the government.

The Jamnitzer goblet, of which a photograph appears, is described later in this article. The Osnabrück Kaiserpokal is preserved in the council house of that city, among other, though less conspicuous, specimens of silverware. A picture of it appears below. As it is by far the most important of the goblets belonging to the Osnabrück plate, we will describe it more fully. This Kaiser cup is an eminent example—perhaps the best in Germany—from the early Gothic period. The shaft of the foot and the figure on the top are additions of the 16th century. The cup proper is poised on a foot having six divisions, and probably possessed formerly a stem or shaft



THE OSNABRÜCK "KAISERPOKAL."

of about the same height as the present one. The lowest attachment still shows that it was executed in the architectural pattern of the early Gothic style. In the center was probably a flat six-sided knob. The bowl and cover are in perfect condition and in every respect as originally made. On the bowl the virtues and vices are represented alternately, in 12 medallions, in lively and rich designs. Very striking are the representations on the lid, consisting of round pictures, with figures which go back directly to Roman antiquity, and were most likely borrowed from engraved stones or cameos. In the gores appear 24 little figures, either dancing or making music, which likewise show ancient influence. The panels, ex-

ecuted in champlevé enamel, evince, on the other hand, a Romanesque character. The seated figure of the Emperor, which is now affixed in the interior, is presumed to have originally appeared on the lid. The origin of this goblet, which is absolutely unique in shape and details, has not been determined.

Of the splendid treasure formerly owned by the Goslar City Council, the guardians of which were the "Six Men" of the Ramelsberg, so rich in silver, only some stray pieces and a few valuable ones now remain. The principal piece is the "Bergkanne" or "Mountain Jug," illustrated herewith—a masterpiece from the most flourishing period of German goldsmithing, and a gala ornament for the table of the mountain barons. We know nothing definite about its origin, and no mark shows the workshop from which it came, but the supposition that it is Nuremberg work seems not without ground.

The jug, or pitcher, is of embossed silver, all the ornamentation laid around it in six bands, being silver gilded. It is 80 centimeters high and 20 broad. On the top of the cover the eagle of Goslar is poised upon a blue globe. Beneath, in an architectural structure, is a figure of St. George as the dragon slayer. Around this, in four divisions of the towerlike crown, the work of silver mining, the source of the wealth of the city, is represented; in two divisions, a lion hunt. Among the six bands of ornamentation, the one which is laid about the largest part of the jug is especially notable; it has nine figures of angels, forming a celestial choir, and in the place of the 10th figure the Goslar eagle. On the foot is the date, 1477. The handle, in the shape of a dragon, reminds one of the models of the early Middle Ages.

Beside this famous piece, two goblets of silver, richly gilded, claim our attention. The work is extremely fine, probably also of native origin; according to an inscription the two were a gift of the Burgomaster Johann Papen, of Goslar, who died in 1506, and whose coat-of-arms is engraved beneath the feet of the goblets, together with the eagle. Another noteworthy piece is a silver baptismal basin, gilded on the inside, with soldered reliefs, representing the Elector Frederick of Saxony, Dr. Martin Luther and the Emperor Charles V.; there is also a fourth figure—that of a woman with bared bosom and loose, floating hair. The fifth figure, in the center, is lost. The Goslar collection possesses, besides, a beautiful ring of a late Roman period, with a mysterious Greek inscription. On the stone is represented a priest kneeling before an altar.

Nuremberg is one of the few German cities which still possess, outside of various modern pieces, a number of silver treasures dating from past centuries. It has, to be sure, only remnants of a once very large and important collection, but these remnants are so valuable that their worth is estimated as at the very least 110,000 marks. The most famous piece of the former collection, the Wenzel Jamnitzer centerpiece, which the city of Nuremberg obtained at the time of its execution, it was obliged to part with in the beginning of the 19th century, to the Rothschilds, for \$150,000, and this is now exhibited in the Louvre. A

good reproduction of it, however, in silver, by Edward Mollenweber, of Munich, adorns the "golden" hall of the Rathaus, and of this we present a photograph. Although two years were spent in making it and it received the first prize, viz., the gold medal, at the Nuremberg exhibition, Mr. Mollenweber let the city of Nuremberg have it for the modest price of 18,000 francs (\$4,500).

The magnificent centerpiece has been constructed upon a simple scheme, but with an incomparable wealth of detail. It consists of a dish which is upborne by a female



"BERGKANNE" OR MOUNTAIN JUG OF GOSLAR.

figure representing "Mother Earth," the dispenser of all the good gifts, typified by a multitude of various species of the vegetable and animal world, such as flowers, plants, amphibia, insects, etc., covering a rock, and most naturalistically executed. At the base of the dish, above the head of the supporting figure, are affixed eight enameled inscription tablets, some of which contain an explanation of the theme upon which the epergne is based. The entire height of the piece is about one yard, the largest diameter 17 inches.

This chief example of the Nuremberg goldsmiths' art shows all its strong points and foibles; an exceedingly rich and attentive elaboration of all the parts, the highest skill in the treatment of the material, a clear reproduction of even the most delicate forms of Nature by a masterful casting, gilding and enamel colors of dazzling charm; but there is a close attention to details that is almost productive of a playful surfeit of decoration. The figure of "Mother Earth," however, that carries the shaft, shows a perfectly free, artistic feeling.

Of the still remaining old Nuremberg silver treasure, two silver goblets, without covers, in the so-called "Ackley" form, 20 centimeters high, are also ascribed to Wenzel Jamnitzer. The bowls have six divi-



REPRODUCTION OF JAMNITZER CENTERPIECE.

sions, the feet three. One of these beautiful goblets formerly belonged to the Nuremberg goldsmiths' guild. Neither have any mark, and it is, therefore, not possible to be certain that they are the work of Nuremberg's greatest goldsmith. A tall bossed goblet with a cover, of silver gilded, was the work of Christopher Jamnitzer. It is 42.5 centimeters high, and on its cover is a cast silver figure of a panther with a fish. A large part of the gala vessels which have been preserved are from the possessions of the former Nuremberg guilds. The grocers' guild gave over to the city a tall covered goblet of silver, partly gilded, dating from 1656, with the mark of Hans

Hirtz and the emblem of Nuremberg. On the plain conical body of the goblet are seen numerous coats-of-arms, belonging to the members of the guild; on the cover is the figure of Justice with her scales. From the inn-keepers' guild came three smaller round silver cups, partly gilded, and two tall gilded covered goblets, 44 centimeters in height. One of the cups bears the inscription, "*Es lebe die Gantze Löbl. Wirthschaft und alle die Trinken daraus, bis Sie Gott ruft zum Himmels Hauss.*"

dallion reliefs, with representations of the vintage, the grape-pressing, and of a rural concert. The foot has equally rich ornamentation. The bowl is upheld by a peasant, in one hand a bag, in the other several cages with birds. On the cover, similarly decorated, are three embossed medallion reliefs, bird-catcher, sower and mower. The cover is surmounted by the figure of a knight, enameled, bearing the Löffelholz coat-of-arms. Worthy of mention is a gilded goblet, the so-called "Münzpokal."



SECTIONS OF JAMNITZER CENTERPIECE SHOWING DETAIL OF THE DECORATION.

To the locksmiths' guild belonged a gilded cup, on whose cover is a figure of Vulcan at the forge. The guilds of the blacksmiths and the weavers furnished two gilded goblets, the first in the shape of a thimble, the work of the Nuremberg goldsmith, Elias Lencker, in the year 1667, the other with 11 little memorial shields attached, mostly silver gilded. Very interesting is a bowl-shaped golden goblet, with a cover, from the year 1536. The foot is decorated with colored enamel, and the slightly convex cover has four portrait medallions of members of the Pfinzing family. Another magnificent covered goblet belonged to the old Nuremberg patrician family of Löffelholz. The bluntly conical body of the goblet has richly chased and embossed cartouches, and three embossed me-

Forty small coins are set into the body of it, and four large Greek coins into the foot. Still another interesting piece is a large bossed, covered goblet of gilded silver, the work of the Nuremberg goldsmith, Friedrich Hirschvogel, in the year 1619. On the cover is a bunch of flowers, in silver, and vines twining around the stem; the whole height is 62 centimeters, and it weighs more than a kilogramme (2.2 pounds). To close our description of these stately drinking vessels, let one more be mentioned—a gilded grape goblet, with cover, from the 17th century, with a foot of many divisions, ornamented with shells, and partly in filigree work. On the cover is a vase of flowers.

There are no table dishes preserved in the collection, except two knives in a white

silver case of filigree work with figures, likewise the work of Friedrich Hirschvogel.

These Nuremberg treasures have been lent to the Germanic National Museum, together with some goldsmith work of later date, also the property of the city, and take the first rank among the exhibits of the kind.

Naturally, drinking vessels figure very conspicuously among the collections in the city treasures, and in times bygone, when drinking was considered a great accomplishment, they were doubtless actually used for that purpose, while the large gob-

netical ownership, and the various municipal treasures now include many handsome pieces of plate, formerly the property of guilds. The above "Goldsmiths'" cup is one of them.

In another Baltic city, viz., Reval, can be found, among other handsome specimens, two fine silver mugs, of superior workmanship, which are illustrated on page 78. The mugs on page 75 belong to the city of Kassel. From time to time fine municipal epergnes such as those of the Hamburg Senate, of Frankfort, etc., have been illustrated on the front page of this publication.

destined to hold flowers. It is two yards high, and weighs 200 pounds. The necessary funds were furnished by patriotic citizens of the city of Leipzig. This epergne is so constructed as not to obstruct the view across the tables or hide any speakers.

Among the illustrations will also be found a few handsome Mayor's chains, an object which of late years has been acquired by many German cities. The one shown in our picture on page 76 is that of the city of Strasburg, and is a gift of the German Emperor. The official chain of the rector of the Kaiser Wilhelm University in Strasburg is also illustrated herewith.

The German Emperor has taken a highly appreciated initiative in honoring certain cities, as a souvenir of his visit, or of a special celebration of an event connected with the city, by presenting a handsome Mayor's chain to the same. This example has been copied by the various other potentates, and has given the goldsmith's art some excellent and fructifying problems to solve. Among the royal gifts of this nature, that to the city of Emden ranks high as a work of art. In its production the laudable condition was made that it should be an example of the goldsmith's art of the city in question. (See page 77.)

The contract was awarded, after a spirited competition among the goldsmiths of Emden, to Fr. Richter, because he submitted to all the requirements stipulated by the committee charged with placing the order. The work, when finished, testified to the fact that the craft has attained considerable perfection in that city. The design was furnished by the instructor in designing at the Royal Wilhelm's Lyceum, Mr. Ruwoldt, who acquitted himself of the task set in a most brilliant manner. The clasp of the chain or collar is formed of a plaquette with the City Hall of Emden embossed in gold, after the Emperor medal, and bearing the inscription, "*In spe et silentio fortitudo nostra*," in accordance with the tenor of the Emperor's Emden speech. The medallion consists of the picture of Emperor William II., painted in enamel, which is in itself a gem of miniature painting. It represents the Emperor in naval uniform; it is surrounded by an oaken wreath in green gold, and surmounted by a diamond-studded royal crown. For a pendant the chain has the coat-of-arms of the city of Emden, in a peculiar framework which is an exact copy of that of the old heraldic charter, and presents a wonderful effect in its plastic reproduction. Ships' anchors and anchor chains unite the coat-of-arms with the principal piece, whose various links are formed of oak wreaths and other ornamental designs, and carry name plates. Deep red precious stones serve for a further embellishment.

The goldsmiths' work in this chain, which weighs 600 grammes, is perfect and worthy of the high donor. It is, as it were, a test of the skill of the representative artist of the city, and such tests are valuable in many ways and a great source of inspiration to the craft.

The antique silver treasure of the city of Emden is, moreover, one of the most famous in Germany, for the collection contains many pieces which are of value to the history of industrial art in the Middle Ages, as well as to the early history of the city



WELCOME CUPS OF RIGA AND LUBLIN.

lets that are fashioned nowadays merely serve for ornamentation in the shape of loving cups, etc.

The municipal possessions of the old cities of the Baltic provinces contain many handsome goblets from more prosperous times, and we present a few that form part of the silver collection of Riga and Lublin. The city of Riga has also a "Goldsmiths'" cup, as shown in the picture. When the various guilds ceased to exist their property, in many cases, passed over into mu-

Of recent years it has become the fashion to employ a sculptor of note for the fashioning of the large centerpieces in the banquet rooms of the council chamber. No less an artist than the well-known Max Klinger was given the commission to furnish a fine silver table center for the beautiful new city hall at Leipzig. Owing to the size of the hall and table, the piece must be of unusually large proportions. It was recently finished, and consists of a figure of a young girl, crouching, and bearing aloft a basket

itself. First among these, may be mentioned the goblet or "Pokal," made noticeable by its symbolic decoration, which was presented to the city of Emden in 1598 by the Merchant Adventurers of London, a mercantile company to which Queen Elizabeth granted great privileges. This goblet is 49 centimeters high and 15 wide, and weighs five pounds.

The cover of this interesting piece is surmounted by a half-clad female figure, bearing a shield upon which the armorial bearings of the Adventurers (containing four fields with lions in the first and fourth and two roses each in the second and third panels, the emblems of the coat-of-arms of the English Empire at the time of the Tudor dynasty, and underneath this flowing water) and those of the city of Emden are united. This specimen, the maker of which is unknown, is remarkable on account of its figural decoration and excellent workmanship. On the lid will be found infantile figures and Satyrs, on the body *Justicia*, *Constantia* and *Temperantia*, on the body *Fides*, *Caritas* and *Spes*, and in the background a landscape with houses.

Another very valuable piece in the collection is a drinking cup in the form of a shell shaped warship, of gold and silver, richly decorated. 34 centimeters long, 68 high, and weighing 2,250 grammes. This was a gift from Mary, Queen of Scots, on the occasion of a treaty of peace and commerce made with Emden in 1557. The original writings, signed by the Queen's

own hand, are preserved in the city archives.

The exterior of the ship's hull is covered with representations of Tritons, mermaids and dolphins, the whole being borne by a

pavilion, a company of drinking men are sitting two of whom are playing the lute, the others singing and merrily clinking their glasses. *Fortuna*, on a golden sphere, with a flag in the hand, forms the point of



MUGS OWNED BY THE CITY OF KASSEL.

mermaid, with uplifted head and arms, whose body below the navel terminates to both sides in a broad fish tail. The poop consists of two stories; in the lower one are three guns and powder casks, while in the upper one, which is shaped like a

the roof, whose four corners are embellished by tortoises. The main mast has two large sails; the fore mast carries smaller ones. Sailors are seen climbing up in the rigging, while two soldiers with spears alongside of the mast act as sentinels. In order to change the ship, or "nef," completely rigged up with silver ropes, into a drinking vessel with a mouth-piece, the fore deck, with mast and prow, which are merely inserted, are removed. The document bearing the personal signature of the Queen have her wax seal, showing her full figure.

A very fine silver gilt covered cup is another member of the unique group. The lid is crowned with a man-at-arms, bearing in the right hand a halberd and in the left a curiously formed shield. The cover is ornamented with Satyrs, rams' heads, masks and figural representations (*Fides* with the cross, chalice and host, *Caritas* and *Spes*). On the cup itself appear a monkey, a tortoise, hunting scenes (huntsmen, hound, stag and hare), among them winged genii with aquatic animals and snakes. Below at the foot are leaf ornaments and fruits, and a frog solidly cast (formerly three). It dates from the beginning of the 17th century and weighs four pounds.

Another silver gilt goblet terminates at the top in a pineapple. The cover is embellished with three Satyrs, fruits, scrollwork and cartouches with masks. On the body of the vessel the following are represented in mythological figures: *Amphitrite*, *Poseidon* and *Kronos*, between which appear starfishes, a knotty tree, herbs and flowers, as well as three heads which are repeated on the foot as man, woman and child. This specimen also dates from the beginning of the 17th century and is about 18 inches high.

The smaller broad cup, generally called "fruit dish with cover," whose point also is formed by a pineapple, is borne by three dolphin-like volutes, which are repeated in the center of the foot or stem. This piece

GOLDSMITHS' "WELCOME"
HANAP AND TWO CHARACTERISTIC MUGS.

FROM THE COLLECTION OWNED
BY THE CITY OF RIGA.



COIN CUP. 1705.

MADE 1651.

MUG. 1676.



CHAIN OF MAYOR OF CITY OF STRASBURG.

holds a number of old city seals, various insignia of executive officials, shields with the municipal coat-of-arms, four of them in enamel on silver chains; and the silver parrot which, at the flourishing time of archery, in the 16th and 17th centuries, the champion marksman had to wear on festive occasions over his sash. There is also an antique silver bell-pull, formerly in the chamberlain's office, a collection of rings and precious stones from the coffins of East Frisian princes, and one recent piece, a silver spade, a gift of Franz Merckens, and destined to break ground for the digging of the Rhine-Ems canal. This spade, which is 1.26 meters long, issued from the workshop of the court jeweler, Hermelin, in Cologne. On the handle of the spade a poem by the donor is engraved. Around this is coiled a silver band, with extended spirals, between which the coats-of-arms of the cities of Hamburg, Bremen, Emden, Munster in Westphalia, Dortmund and Duisburg appear in enamel. On the blade is the dedication by the donor.

We are fortunate in being able to present an excellent photograph, specially taken, of the whole Emden treasure, and may add that the afore-mentioned estimate of the value is a very conservative one, for Rothschild, of Paris, at one time offered

is of great historic interest. As an interior inscription demonstrates, it was donated by Gen. Werner du Bois, who in 1602, as commander of the municipal and general state troops, stormed for the city the Logumer trenches put up by Count Enno III. On the bottom of the cup the outlines of these trenches are engraved, as well as the nearest surroundings on water and on land, the position of the besiegers and the besieged being indicated by soldiery and cannon and that of the beleaguered fleet by sailing men-of-war in full fire. Crown Prince Frederick Wilhelm (later Emperor Frederick III.) had a replica of this cup made as a present for the golden wedding (June 11, 1879) of his parents, Emperor Wilhelm I, and Empress Augusta. Subsequently the Berlin Art Trades Museum also ordered a copy. This interesting goblet is dated 1603.

There are also a rose water jug and basin, both of silver parcel-gilt—gifts of the city of Strasburg. The handle of the jug consists of a feminine upper body with strongly pronounced busts. Below at the foot are angels' heads with wings between fruit garlands, and beneath the spout, a face surrounded by rays.

The center of the basin shows in embossed work a rich profusion of landscape and fruit garlands, enclosing the municipal coat-of-arms of Emden. These two vessels date from about the year 1582, and were used after festive banquets in the council house, especially if princely persons were present, to proffer rose water to wash the hands in.

The whole silver treasure of Emden, including the pieces described, is appraised by experts at 553,500 marks value. Recently the entire treasure was sent to Hannover, to grace the festive board on the occasion of the Imperial banquet there.

The cabinet containing the treasure also

CHAIN OF OFFICE OF THE
RECTOR OFTHE KAISER WILHELM
UNIVERSITY AT
STRASBURG.

the sum of \$125,000 (500,000 marks) for the second cup on the left, which is considered the most valuable piece of the collection outside of the "Nel-Goblet" in the center.

The council of the city of Dresden possesses a most peculiar table decoration of recent date by Karl Gross, executed by Hermann Ehrenlechner, of Dresden. It is made of silver in embossed work, embellished with Saxon semi-precious stones and pearls. It has something of the appearance of a tree, the 12 outstretched branches or "arms" bearing fruit capsules which can be opened, and reveal allegorical figures carved in ivory. The whole is a work of novel shape in which the creative genius of the maker has been convincingly demonstrated. The city of Dresden also owns a very fine gala inkstand in repoussé gold, with ivory and precious stones; also the "Golden Book" of Dresden, an excellent work in the goldsmithing line, a silver inkstand and a characteristic ballot box.

There are few German cities of note that do not possess something in the way of municipal treasures, antique or modern, and no attempt is made here to cover the entire field. Only some of the most interesting specimens have been selected, and an effort has been made to leave out all that has been previously illustrated and described in this paper. It is devoutly to be wished that an equally powerful incentive to produce



EMPEROR WILHELM'S GIFT TO THE CITY OF EMDEN.



PORTRAIT SHOWING ENTIRE MUNICIPAL TREASURE OF THE CITY OF EMDEN.

such beautiful pieces may ere long be furnished to the American silversmith, and that a desire for municipal plate may soon become manifest in this country.

How the Tourmaline Mines of Burma Are Worked.

"TOURMALINE is found in separate crystals in the interstices of hard, granite-looking rock. As a consequence men with no means find it occasionally profitable when they have leisure to dig down eight or 10 feet on the off chance of finding some not very valuable bits," says

is found with the granite. When a vein is once found it is followed up as far as possible, subject to the five-fathom limit alluded to above. What, however, makes the mining so exciting and at the same time keeps the industry fluctuating is that the tourmaline crystals are only found intermittently in the vein.

"One may get several in the length of one yard, and then they will unaccountably cease. Directly one man strikes a vein yielding crystals every one who can commence digging along the line of the vein, but it is all a toss-up as to whether, when the vein is reached, there will be tourmaline therein. Adjoining Twinlons give abso-

an outcrop, and it is a matter of pure speculation where to dig," says Mr. George. As the whole place is covered with jungle, prospecting any way would be laborious. There have been three finds, each causing a rush. The first was seven years ago at Hpai Baing (Milaunggon), about a mile to the south of the present place and near where the Chinese had worked formerly. The next was a year or two later at Htaukat between Milaunggon and Sanka.

Then there were three or four lean years, and then, early in 1905, one Konhkan struck a vein, near Sanka village, which has attracted the present growth of population to Maingnin, but, as explained above, though the area within 100 yards of Konhkan's original shaft is honeycombed with pits, only three are yielding, and Konhkan's twin has ceased to yield. All the material dug out from the inside Twinlon is pulled up to the surface in small buckets, all worked by enormously long pivoted bamboos worked with a counterpoise, and the tourmaline is sorted out of hand, the granite fragments being piled in a wall around the mouth of the shaft.—*London Globe*.

Casting a Bronze Statue.

"IMMENSE pains and immense labor attend the production of a bronze statue of any size, even after the artist has done his work," remarks a sculptor.

"To begin with, the plaster model has to be completely covered with small lumps of a special kind of sand, sometimes as many as 1,500 or 2,000 of these pieces being required. After these blocks of sand are dry they are taken off the cast one at a time and carefully put together to form the mold. The latter is then filled with clay, and the same operation is again gone through, a fac-simile of the plaster cast being thus obtained.

"Then comes the most delicate part of the whole work. The clay, model or 'core,' as it is technically called, has to have a quarter of an inch taken off its entire surface, which is anything but easy, especially if the subject is at all ornate.

"The core is then again put into the mold—which has, of course, to be reconstructed once more—being kept exactly in the center by means of iron rods.

"The molten bronze is then poured in from the top, completely filling the space between the core and the mold. After it has cooled the latter is again removed and the clay interior extracted, when the statue, somewhat rough and needing a slight touching up, is revealed."—*Crockery and Glass Journal*.

Consul General Philip C. Hanna writes that the trade in glass products in Monterey, Mexico, is now important compared with that of a few years ago. The most of the ordinary window glass comes from Belgium and Germany, and the annual sales represent a value of \$10,000. Plate glass comes from the United States, the annual trade amounting to \$5,000. The trade in lamps and table ware, etc., amounts to \$60,000 per annum, nearly all being of American manufacture. In cut glass there is an annual business of \$12,000, five-sixths of which comes from the United States.



TWO OF THE MUGS OWNED BY THE CITY OF REVAL.

C. S. George, Deputy Commissioner, Ruby Mines District, Burma. "This system is called *Kathe taik* or *Kathe* system, after the idea of the original ruby diggings at *Kathe*. The next method is the ordinary *Twinlon* method of sinking a vertical shaft about four or five feet square. By custom the owner of the shaft is entitled to extend his workings underground anywhere to a radius of five fathoms from the center of the shaft.

"The vein is formed by a vein of white, hard granitic rock, in the interstices of which the tourmaline is found, at times adhering loosely to the rock, at others lying separate in the loose yellowish earth that

lutely different results, and it is calculated that at least two-thirds of the shafts sunk, yield nothing at all, while only an occasional one is at all rich."

Of the 62 *Twinlons* at the time of Mr. George's visit only three were yielding, and of these only one had traces of the best quality stone. The "veins" are fairly deep down, none having ever been reached at a lesser depth than nine fathoms, while an ordinary depth is 40 or 50 cubits; when the "vein" takes a downward direction it is followed as far as possible, but that is rarely ever about 60 cubits, for at that depth the foulness of the air puts the lamps out.

"The vein is said rarely, if ever, to show

Progress Made by Class in Jewelry Manufacturing at the Newark, N. J., Drawing School.

THE accompanying illustration shows a class of pupils at work in jewelry designing and manufacturing at the Free Drawing School at Newark, N. J. The designing department of the school was started some time ago, and was such a success that it was found advisable to add a department where the students could not only design articles of value, as jewelry, but could be afforded the privilege of working out their ideas in various metals.

At the opening of the school last Fall decided evidence of interest was shown in the work by the enrollment of a full quota of pupils, and many were disappointed in having to be turned away. The interest in the work has been keen from the start and increases as the work continues. As the pupil advances in the work the designs which he creates and works out becomes more com-

to keep artistic bits of the jewelry work at the school for a reasonable time for exhibition purposes. When the work in metals first started the pupils were given a copper to work in, but it did not prove satisfactory.

There are two divisions in the course, jewelry designing and manufacturing, with about 20 pupils in each division. Each division meets two nights a week, and both have the option of a third evening to work, if so desired, but the instructors are not present on the extra evening. The class includes both men and women, and there are none in either class who has not had at least one year's experience at the jewelers' bench, and with such practical preparation it is becoming evident that the pupils will make rapid progress.

The equipments of the room in the Free Drawing School building, where the course

themselves, consequently the instructor has given much attention to the creation of an artistic taste in his pupils in design making before they attempt to reproduce their ideas in metals.

He has taught them to adopt certain designs to a certain area, and to design according to artistic principals, so that the result reached would have artistic merit; and while the work of designing is in progress the pupils have been impressed with the fact that the designs which they are drawing are later to be used and worked into metal.

The manufacturing jewelers in Newark and vicinity have from the first showed a decided interest in the jewelry class, and have encouraged the formation of the class, and in every instance showed their appreciation of the work. In some instances employers have urged boys and young men to take up the course; they have gone so far as to send personal letters to Prof. Leche, of the Free Drawing School, in which they have stated qualifications of the various applicants from their several shops.

The work is already well under way, and



A CLASS OF STUDENTS AT WORK IN THE JEWELRY MANUFACTURING DEPARTMENT OF THE FREE DRAWING SCHOOL, NEWARK, N. J.

plicated, and he is thus given an opportunity to bring out his own ideas in the jewelry work.

All the work done is original in that no designs are copied from other pieces of jewelry or drawings; it is the idea of the school to foster and develop the ability of the student in original work and each pupil is urged to indicate his ability by original drawings and their executions in different metals. This manner of procedure will create in the pupil an artistic taste and has thus far resulted in the development of many different designs.

Silver has been chosen as the metal for the pupils to work in, generally speaking, because it is an easy metal to work, and then again it is comparatively cheap. The silver is sold to the pupils at a minimum price and the articles made by them during their instruction become their personal property. It is the intention of the directors

in jewelry designing and manufacturing is taught, is very satisfactory and meets all the needs of the pupils. In one corner is a large hood, used to convey the fumes from the room; a small furnace for melting metals is also in evidence, while the lathe will also be of general use as the course advances. Every bench is supplied with the necessary tools and instruments used by jewelers. Every bench where the student works is fitted up like a jeweler's bench, having a large drawer and tray underneath.

Henry Grasmuk, instructor of the class in jewelry designing and manufacturing, is a man of well-rounded experience in both teaching and making jewelry. It is his aim, primarily, to develop the aesthetic side of the pupil's nature and help to bring him to a higher level of appreciation of the artistic in jewelry designing and workmanship. The execution of designs is said not to be as difficult as the making of the designs

the present indications show that much is to be expected from the course in jewelry designing and manufacturing. The training received at this school will lead the pupils to a higher conception of the artistic in jewelry manufacture and will be of financial benefit to them.

The pearl shell business in La Paz, Mexico, is controlled by two companies, says our consul. When placed on the market they are graded in three classes, quoted at present in La Paz at the following figures American money: First class, \$200 per ton; second class, \$100 per ton; third class, \$50 per ton. The output is now nearly all shipped to Liverpool and Hamburg. The prices now are 10 to 20 per cent. lower than an average, and are governed by the quotations in Liverpool and Hamburg, less cost of transportation, which is about \$18 per ton.

The Influence of Style in the Silversmith's Craft.

By W. AUGUSTUS STEWARD,

Chief Instructor in Gold and Silversmithing at the Central School of Arts and Crafts, London, England.

WE often glibly talk or write of *style* as though it were the simplest thing in the world to explain. It is not! Like life itself, it is changing, and what is more is evolutionary. It sometimes moves with an irresistible force, sometimes seems to have stood still, and in between whiles been

to go back to the earliest days of dawning civilization to find the basis upon which modern design was based.

This should be apparent to any studious silversmith who has taken the trouble to compare the specimens of his predecessors' art which are to be found in the museums. Exactly where the dividing line may be drawn as to the origin of the fundamental basis of the design and the designers inventive faculty is not an easy matter, but with a guide who understands his subject and can explain it the student may not only master the principal features which denote the influence of earlier work or, as we generally put it, style, but finds himself engaged in a most fascinating study.

The style which was the outcome of Grecian civilization (and was at its height during the fifth and fourth centuries B. C.) not only imposed its influence upon the Roman conquerors, but is apparent in much of the work of the renaissance and of today, while the Egyptian, Byzantine and As-

foresight and perseverance of Dr. Schliemann, would have been known to us only by reading Homer, and then simply accepted with the sceptical mind which could only conceive the extraordinary descriptions as being merely the word pictures of a great poet. The excavations in Pompeii and Her-

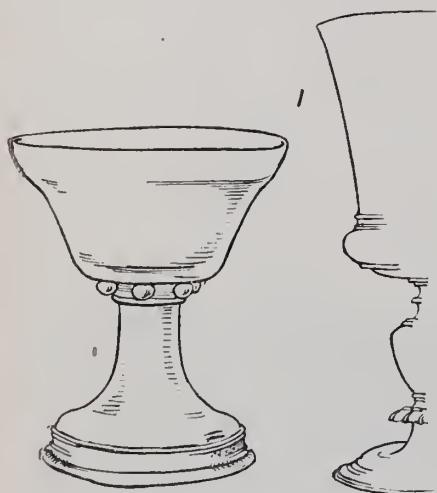

THE "ANATHEMA" CUP, 1481. LONDON, 1580. NOTE SQUAT BALUSTER STEM.

retrogressive. But in the same way that we have to scientifically deal with the problem of human life and progress and its march down the ages, so we must bring to bear a reasoning and analytical spirit when discussing the question of style in art or craft.



LONDON, 1667. "WHITLEY EWER," 1680.

syrians have left traces on the productions of those who have, during the long centuries and right up to the present time, been connected with the applied arts. And so we shall find, when discussing the productions of 18th century silversmiths particularly, that the greatest difficulty is experienced in assigning style to definite periods. Fortunately we are sometimes chronologically assisted in our judgment by "Hall" and "Makers" marks, but so quickly did period sometimes follow period that it is difficult to find pieces which do not bear marked influence of the preceding style, while it sometimes happens also that some designer, far ahead of his time, produced a single object which many years after became the basis of a style; for instance, the famous "Anathema"* cup at Pembroke College, University of Cambridge, England, which bears the hall-mark of 1481, but is apparently a forerunner of a style prevalent nearly 100 years later.

And if we would deal with our subject in a thorough manner we must commence at a period which was once wrapped in the mists of antiquity and which, but for the

*So called because of the inscription which it bears, "Qui anathema sit."



"NUREMBERG CUP," GERMAN, XVII. CENTURY. SILVER VASE BY CLAUDE BALLIN, FRENCH, XVII. CENTURY.

culaneum in the 18th century largely revolutionized design in many directions, including that of the silversmith, while the discoveries in the 19th century by Dr. Schliemann at Mycenae, Troy and elsewhere in Greece, of the Gracco-Roman treasure on Hildesheim and of Boscorcale, and the various isolated finds elsewhere, have done much to influence whenever a "smith," imbued with the artistic spirit, has made a study of the objects which are now safely cased in the various museums.



"IRISH CUP," 1716. HALL MARK, 1699. QUEEN ANNE PIECE, 1701.

In the silversmith's art of the Renaissance we naturally find the influence of ages long forgotten, for the beginning of the 15th century saw the revival of the antique arts in the land which had produced the unsurpassable Etruscan goldsmiths and had, before successful conquests satiated and enervated her, encouraged Greek artists and craftsmen and founded the Gracco-Roman style. We must not, however, overlook the



LATE WILLIAM AND MARY, LONDON, 1700. SHOWS INFLUENCE OF RENAISSANCE AND CLASSIC.

There is the old and common observation that "there is nothing new under the sun." In a measure it is a trite saying which covers much, for we may discuss the styles designated Gothic, Celtic, Elizabethan, Queen Anne, Rococo, Adams, the various Louis, Georgian or Victorian, but we shall have

fact that the Gothic style which preceded that of the Renaissance has had considerable influence upon silversmiths' productions, and a few remarks concerning this style will help us in our discussion, since we shall be able to emphasize our point with respect to the overlapping of styles and the influence one upon another, for early Gothic metal work shows traces of Byzantine tradition in both design and workmanship,

the period, which is sometimes alluded to as the "dark ages." So if we follow specimen pieces of Gothic work we shall discover that the silversmith ultimately strove to free himself from the architectural tra-

city, and said to be the model for the masterpieces of the goldsmiths, is based upon the columbine.

The artists and craftsmen of the Renaissance looking upon Gothic as barbaric would also have eschewed classic forms, but the rebirth of art was, as I have stated, in the home of artists and fine craftsmen, and whether they would or not it was impossible to escape the dormant, native spirit. The



TWO BODIES AND HANDLES OF EARLY GEORGIAN COFFEE POTS, LAMERIE STYLE.

while at the end of the 13th century contemporary Celtic work made its impress also. It should also be noted that during this period architectural forms were much used by the silversmith, and in the church work particularly he used architectural forms and embellishments, buttresses, canopies, pinnacles, open-work windows, crenulations, mouldings, etc., for this was the most likely to please the ecclesiastics by

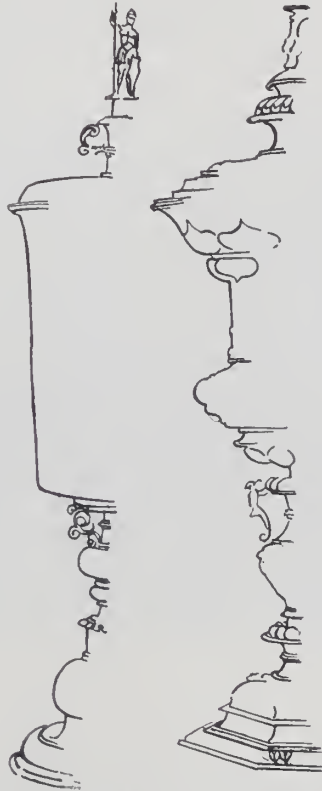

BODY LIKE BRITISH CHALICES OF MIDDLE XVI. CENTURY; AUGSBURG, XVII. CENTURY.

RENAISSANCE, XVII. CENTURY. LIKE XVI. CENTURY IN ENGLAND AND LIKE "KAISER" CUP BY JANNITZER.

ditions and obtained his inspiration from nature. So in the later Gothic silver objects, in German particularly, we note the bossings which were doubtless conventionalized renderings of the umbriated calyces of the "holy thistle," while the curling tape-like embellishments which we see under "members" of a standing cup, or under the modeled button of its cover, were conventionalizations of the "holy thistle" itself. This bulbous treatment of "bodies" (which is almost peculiar to German work of this period), as is the case in the rendering of other styles, was sometimes overdone, as

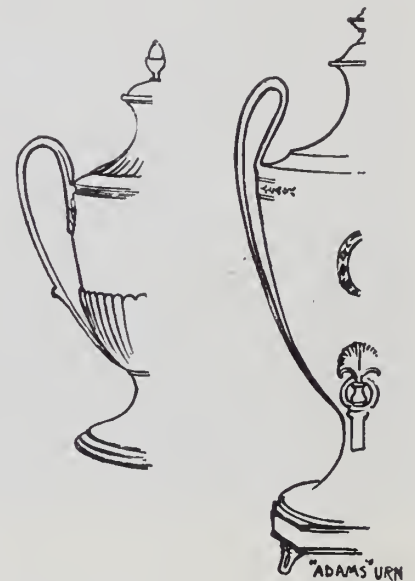

"ADAMS" STYLE, GEORGE IV. PERIOD.

XVIII. CENTURY.

soil was, so to speak, being worked again, and Roman ideas were destined to again play an important part in the world of art, the bounds of which were now, however, much wider. The craftsmen of the Renaissance drew their inspiration from sculptured relics of Rome's past glories, and this accounts, in a large measure, for the harshness which is often characteristic of the style. Benvenuto Cellini, whose name

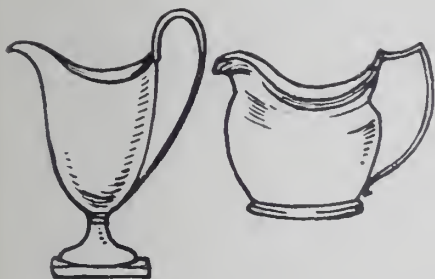

GEORGE III., 1793. GEORGE III., 1803. THIS STYLE, HOWEVER, PREVAILED ABOUT 30 YEARS PREVIOUSLY.

whom he was employed, and moreover he was largely bound by tradition.

It is to the existing products of the old German silversmiths' art that we must largely turn when discussing the work of this period, for unlike their contemporary craftsmen of Italy, France, England and Spain they were the inhabitants of well ordered cities situated in a large territory and less likely to be disturbed by religious quarrels or civil wars. It was these unfortunate happenings which were responsible for the loss of so much of the silversmiths' work produced in the other countries I have named. As a consequence German mediæval silver is to be found in every good collection and helps us to appreciate the work of



LIKE BUTTER BOAT ATTRIBUTED TO PAUL REVERE. 1761

were also the ornamental crestings and embellishments which were intended to enrich the body, stem and cover. The famous Nuremberg cup, designed by Wenzel Jannitzer, in the municipal collection of that



1714.

stands foremost among the goldsmiths of this period, has been called "the spirit of the Renaissance" (in some ways a very turbulent spirit according to his own admissions), but in his autobiography he frankly states that he was helped by clever art craftsmen whom he names, while there can be little doubt that much work attributed to him was the product of other remarkably skilful silversmiths. In writing of the early Gothic I have stated that it was largely architectural; indeed this influence was never wholly lost, but much of the jewelry of the Renaissance was also architectural and statuesque, showing that much as the craftsman of the 15th century wished to free himself from Gothic tradition, he

found it impossible. Cellini's famous gold enameled salt cellar with a male figure representing the sea and a female figure symbolic of the earth is a remarkable example of this.

In England the *renaissance* became established in the Elizabethan period largely owing to the employment of Italian artists who had settled in England at the instance of

paring the way for what is known as *baroque* style, which later influenced a deal of the work of the 17th and 18th centuries by its coarse and over-elaborated decoration.

From the end of the 16th century and onward during the reign of James I., a period of ostentation and luxury, the products of British silversmiths were very ornate; in fact it would appear as though they must

kept busy in the production of elaborate toilet pieces as well as handsome looking objects for the buffets. The plague of London and the "Great Fire" which followed were fatal to the gold and silversmiths' craft, while the closing of the exchequer in 1672 spelt ruin to the almost newly established banker-goldsmiths.

This aggressive ornamentation led to a revulsion of feeling, and the plain surface, which demands a clear, good outline of the object itself, and which has been and still is essentially British, became fashionable.

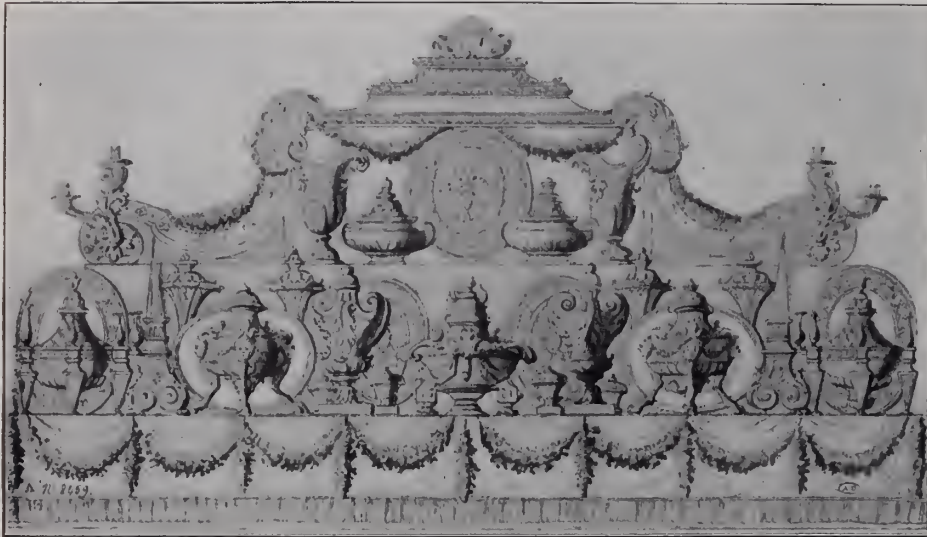

SILVERWARE. LOUIS XIV. PERIOD. IN LE NOUVEAU MUSÉE DES ARTS DECORATIFS.

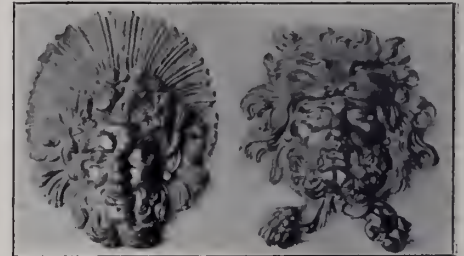

SILVER FITMENTS. FRENCH. LOUIS XIV. PERIOD.

Henry VII. and Henry VIII. But here again the influence of the "Tudor" period made itself felt, and as a result English renaissance was less ornate than Italian, French or Spanish, but the characteristic "strapwork" floral decoration and the cartouche were much in evidence. It might be expected that mention should be made of the influence which the Reformation may have had, in common with the Renaissance, upon the English silversmiths' craft, but although there is little doubt that Henry VIII. and Cardinal Wolsey had splendid collec-

have vied with one another in the task of crowding ornament onto ewers and rose-water dishes, these being particularly overdone with mixtures of masks, strapwork, arabesque, etc. This ostentatious style continued into the reign of Charles II. (coinciding practically with Louis XIV. of France), and for a time the goldsmiths were

The "Whitley Ewer," which once formed part of the corporation plate of Chester, is a Charles II. production (1680), which in its simple lines anticipates the future. Note the "cut card" applied ornamentations at the base of the body and quasi-classic handle in the sketch. There is also another specimen extant of this peculiar style which stands out among the ornate work of the period. It is a cup with shaped body and cover, the simplicity and clever smithing of which appeals to one. It is spoiled, however, by the niggling, fussy handle.

The French productions of the period.



SILVER SALVER. FRENCH. 1698.

tions of plate, yet nothing remains to show us what fine work was produced except the jealously guarded sketch of a cup, by Holbein, in the British Museum.

There is, however, a good deal of 16th century plate still in existence, and at a recent exhibition in London no less than 80 pieces of the period were shown. In Italy the designs of Michael Angelo were pre-



SILVER TRAY. TULIP BORDER AND PASTORAL SCENE. HUNGARIAN. XVII. CENTURY.

known as Louis XIV., have peculiar characteristics of their own, as will be seen by the illustration of a buffet of the period garnished with table silverware of the 17th century. This is in Le Nouveau Musée

same. This price being above that ruling in the market, the inducement was so great that, in the end, another law had to be passed to prevent coins being melted in order to manufacture plate, but not before large quantities of old, and to our way of thinking, valuable plate had been destroyed. I mention this interesting but little known item in English history because it has an important bearing upon the silversmiths' craft, as it placed a higher value upon silver plate than had hitherto existed. Prior to the passing of this act the standard for silver plate was the same as that for coin of the realm. The new standard was 959 fine or "Brittania." This act became operative in 1697, but in 1720 a law was passed which again made the old standard legal, although it *did not* render the act of 1697 illegal, but merely inoperative, for although it was seldom necessary for the assay offices to mark such quality, up to the present time it is a legal standard and is marked as such, if need be, by any British assay office.

the "Treasure of Hildisheim," the edges of which are "crimped" at lengthy intervals.



SILVER TANKARD. DUTCH. XVII OR EARLY XVIII. CENTURY.

des Arts Decoratifs in Paris. It gives a good idea of the various items which composed a side service, and also the blunt directness of a style which does not appeal with any force to designers of to-day. The cartouches of this period exhibit Greek influence, while the appliqué ornament (illustrated) bears unmistakable renaissance influence.

William III., experiencing difficulty in

So far as English work of the 17th century is concerned it will also be found that some of the later work was influenced by the floral Flemish style. There is a very fine example of this kind of work in the South Kensington Museum. It is a Flemish dish made in 1670, with a light and very graceful flowing, conventional, floral scroll running round the flat, somewhat like the dainty chased work on the large bowl in



SILVER EWER. ONCE PROPERTY OF MADAME DU BARRY. FRENCH. XVIII. CENTURY.

Of an even lighter and more graceful character is the ornamentation on a French sal-



SILVER GOBLET. ENGLISH. XVIII. CENTURY.

obtaining the requisite quantity of silver for coinage purposes, caused a law to be passed which was framed to encourage owners of plate to take it to His Majesty's mints and there to receive 5s. 4d. per ounce for the



SILVER GILT CUP AND COVER BY PAUL LAMERIE. LONDON, 1739.

1840
Randel & Baremore

1866
Randel, Baremore & Co.

1880
Randel, Baremore & Billings

1897
Chester Billings & Son

CHESTER BILLINGS

1840 & SON 1908

SUCCESSORS TO
RANDEL, BAREMORE & BILLINGS

IMPORTERS OF

DIAMONDS
OTHER PRECIOUS
STONES, & PEARLS
DIAMOND JEWELRY

NEW YORK: 58 NASSAU
STREET, 29 MAIDEN LANE
LONDON: 22 HOLBORN VIADUCT, E. C.
PARIS: 53 RUE DE CHATEAUDUN
AMSTERDAM: 2 TULP STRAAT

ver made in 1698. (See cut on page 82.) Tulip decoration in the same manner was also applied to both English and Flemish circular dishes, and this latter form of decoration is to be seen on caudle cups produced in England about 1660-70 and later in the 17th century. I give an illustration of an Hungarian silver dish of the 17th century, showing this form of decoration on the flat or rim of the dish encircling a pastoral scene. (Page 82.)

When James II. came to the British throne in 1685, the prevailing idea of decoration was borrowed from the Far East, and Chinese figures and ornaments formed the basis of many designs engraved upon all kinds of silverware. This style was also



AFTER JOSIAH WEDGWOOD'S STYLE, BUT FRENCH. XVIII. CENTURY.

carried into the reign of William and Mary, which terminated in 1702.

Spanish silversmiths' work of this period is very ornate with overdone scrolls, and a mixture of conventional shells, grapes, etc., all mixed up in a manner which affrights an artist. On the other hand, German work of the 17th century, particularly the productions of Augsburg, is delicate and rich. Specially noteworthy are some charming examples which Mr. Pierpont Morgan has in his collection. Some very rich nautilus cups of this period, with parcel gilt mounts all delicately built and arranged, are fortunately still extant.

I give a sketch on page 80 showing details of a helmet shaped gilt ewer (in the possession of the Duke of Portland), bearing the London hall-mark of 1700, which

shows the classic influence to advantage. It is, of course, Renaissance in style, but much more reserved in its ornamentation than most ewers of the period. The helmet-shaped ewer, of which this is a good specimen, was introduced into France from Italy by Andronet du Cerceau at the end of the 17th century. This object was, during the Renaissance period, together with the dish



SILVER, PARCEL-GILT TANKARD. STRAPWORK ORNAMENT. AUSTRIAN. HALL-MARK, 1731.

en suite, the richest object for the buffet, and always occupied the place of honor thereon.

The two ewers (page 95) of oviform shape, designed in the middle of the 16th century, give an idea of the work which



SILVER TAZZA AND COVER. LATE XVIII. CENTURY. CHARACTERISTICS OF AN EARLY PERIOD.

was expected to be placed in these objects. In both instances it should be noticed that masks are used on the body and the female torso, like that used in modeling the handle of the gilt ewer mentioned above, is utilized in the design of the ewer with the acanthus ornamentation on the base of the body and under the lip, while a male torso is arranged in the handle of the one with

arabesque marks and amorini ornamentation disposed on the body. These ewers of pure Renaissance design give an excellent idea of two of the salient characteristics of silversmiths' work of this period, and which, it will be seen, have been incorporated in 19th and 20th century designs.

The foregoing is intended to indicate the incentives which forced manufacturers in the early part of the 18th century and, incidentally, to suggest reasons for the variety of plate made before that date. During the reign of Charles II., Dutch influence had been at work, but toward the end of the reign of William III., largely owing to French influence, design in silverware was greatly changed. The work of these men,



DESIGNED AFTER JOSIAH WEDGWOOD'S STYLE. DATE, 1774.

who were refugees owing to the revocation of Nantes, had a restraining influence, and the early work of the Queen Anne period demonstrates this very forcibly. Toward the end of her reign, however, though the bodies of objects in silver remain comparatively simple in form, there is a greater tendency toward elaborate ornamentation. The elaborate ornamentations and flamboyant character which was such a feature of certain classes of silverware up to this period were eschewed, and the simple, forceful style which the reign of William and Mary gave promise of was realized in the short reign of Queen Anne. This style was plain in form and simple in ornamentation. It was, indeed, severe in comparison with the work of the hundred years which had preceded it. But in discussing the style of

MOUNT & WOODHULL,

IMPORTERS OF

DIAMONDS, OTHER PRECIOUS STONES
AND PEARLS.

Artistic Mounted Jewelry

26 MAIDEN LANE

(Southwest Corner of Nassau Street)

NEW YORK.

ADDISON W. WOODHULL, President.
FRANK K. HUFF, Vice-President.

WILLIAM J. McQUILLIN, Secretary.
GILBERT T. WOODHULL, Treasurer.

Queen Anne we must admit that once again we are dealing with an aspect of art which is a revival, for "Queen Anne" was in great measure a revival of Charles I., the plain character of which was continued during the Commonwealth, when, however, though plain, silverware was made very heavy in appearance.

With the accession of George I. a new force in the domain of British silversmithing came into power in the person of Paul Lamerie. His productions were varied and numerous, in some instances comparatively simple, though fully ornamented; in others not only overdone in form, but exceedingly elaborate in the intricacy and massing of ornament. To some extent his work shows the influence of the Louis XIV. style, which prevailed in France and dominated design in England between 1730 and 1755, and of the patchwork Rococo which, with its vegetations in metal and strange meaningless scrolls, exercised such an influence over design in the early period of the reign of Louis XV. in France by irregularity of form, and in England by the heterogeneous massing of shells, fruits, vegetables, etc. The latter years, however, of the Louis XV. period shows considerable improvement in the general quality of French work, but we observe that the Rococo style is still very much in evidence and that, though designers use more judgment, festoons, flowers, gad-ronings, etc., are still used in great profusion. Earl Cowper possesses a very elab-



PIERCED CAKE BASKET. MADE IN SHEFFIELD. SECOND HALF XVIII. CENTURY.

orate cup with cover, the work of Paul Lamerie. It is terrible in its swirling, massive looking scrolls intertwining masks, shells, grapes, etc. It is, indeed, Bacchanalian, especially in the sense of design, run riot.

The fine silver gilt two-handled cup with cover, bearing the London hall-mark 1739, which I am able to illustrate (page 83) is richly ornamented with satyrs heads and "swags" of flowers arranged alternately round the body and on the lid. It will be observed in this design that the contour of the body of the cup is of that simplicity of form which characterizes double-handled cups of the Queen Anne period. This cup is a treasured property of the Worshipful Company of Goldsmiths of London, who also possesses a silver gilt ewer, standing 19½ inches high, made by Lamerie in 1741. This massive helmet-shaped ewer is ornamented in very bold relief and is typical of the Rococo style. The foot is covered with marine flowers, reptiles and shells with swirling, meaningless scrolls thrown on and helping to form an irregular edge. The body has below an ornamental reeded band, a winged mermaid attended by two boy tritons blowing couch-shells, while above are ornate swaging flowers, more or less conventional, and under the lip the arms of the company in relief. The handle is formed of a sea god, terminating in scroll work, strongly indicative of Renaissance helmet-shaped ewers. This piece is somewhat French in feeling, but an ewer produced in France at this time would have been fluted and a good deal more made of the marine motifs. The silver soup tureen, shown on page 91, of this period, however, demonstrates the exceptional character of some French work of this date, although the



VASE AND COVER. DESIGN BY FLAXMAN. LONDON. HALL-MARK, 1805-6.

ORDER

DIAMONDS

ON MEMORANDUM FROM

ALFRED H. SMITH & CO.

London,
6 Holborn Viaduct.

170 BROADWAY, NEW YORK.
Corner Maiden Lane.

Also 475 FIFTH AVENUE.

Chicago,
103 State Street.

characteristic feeling is shown to most advantage. Floral swags and flutings are a good indication of the work of the beginning of the second half of the 18th century.

Toward the end of the 18th century, the Rococo and Louis Quinze styles were succeeded by the "Louis Seize," in which, thanks to the discoveries at Pompeii, everything was made oval in form and the object decorated with gracefully disposed wreaths, ribbands and medallions. In England, Josiah Wedgwood, the Brothers R. &

plied to both Wedgwood ware and silver. The Adams brothers applied their ideas particularly to architecture and furniture, but the influence which they had upon the craft of the silversmith is unmistakably seen in the V-shaped oviforms which are so charmingly characteristic of the "Adam period." Both Greek and Roman forms were used by the four men I have named.

And here I might remark upon the misleading eulogies which have recently been made by American writers with regard to early American silversmiths who, in their stern surroundings, were impelled to think more simply and so conceive objects of simple form and sparse decoration. So far, so good, but—the facts of history should not be ignored in order to heighten the character of a patriot. The qualities and character of Paul Revere are not enhanced by shallow claims to his great knowledge of classic forms. As a matter of fact the tea urns and sugar vase which have so often been shown to prove his "classic sense" are almost duplicates of objects produced in England during the early "Adams" period, and yet we are told that he produced these fine forms "without guide other than his own acute instincts and the traditions of the provincial masters." It would appear that the eulogist of Revere was a little doubtful after all when we read the qualifying statement about traditions, and, as a matter of fact, like most of us, he was unable to get away from traditions. There is nothing so tenacious as the tradition of the workshop and the craft. Revere was a fine patriot, but he was not an exceptionally brilliant artist—silversmith. We could hardly expect him, living in a comparatively new country, to be a genius; much was against him, and he did well in taking for his models the productions of England and France. I give a rough sketch of an English made sauce boat bearing the hall-mark of 1761, which is almost identical with one accredited to Revere. Compare likewise the rough sketch of an "Adams" urn. If we also compare the productions of other

American silversmiths we shall find that their porringers are copies of English patterns prevalent in the time of William and Mary and, at a later period, that the tea-pots are of common English design.

It is not my intention to in any way decry the quality of the work turned out by



FRENCH. MIDDLE OF XIX. CENTURY.



SILVER PARCEL-GILT TAZZA AND COVER. FRENCH. MADE 1851.

J. Adam and John Flaxman were the leading exponents of this style. Wedgwood was the famous potter, the brothers Adam were architects and Flaxman was a sculptor and Royal Academician who delighted in founding his designs upon a classic basis. He designed a series of panels and medallions illustrating various scenes in Greek mythology and history, taking for his models remnants of Grecian sculpture, and we see the greater portion of his work specially ap-

"Colonial silversmiths," but just incidentally to urge the necessity of approaching an historical subject with the historical spirit, and secondly to demonstrate as forcibly as I can the influence and domination of style.



SILVER ICE DISH BY DODD. 1851.

SILVER CENTERPIECE BY WILKINSON & CO. 1851.

SILVER VASE BY MESSRS. GARRARD.

CENTERPIECE, THE SEASONS, BY FROMMENT MEURICE.

STERN BROS. & CO.

CUTTERS OF

DIAMONDS

68 Nassau Street, New York

Cutting Works, 138-142 West 14th Street, New York

CHICAGO
103 State Street

LONDON
29 Ely Place

The classic knowledge of the Adams, as I have stated above, was fostered and emphasized by Josiah Wedgwood and John Flaxman, R.A., whom no modern sculptor has yet surpassed in the embodiment of fine classic feeling in objects of applied art. He materially assisted Wedgwood in the design of the beautiful ware which bears his name, but he also applied his art to the silversmiths' craft and so, from our point of view, became a considerable factor in the late 18th and early 19th centuries. The fine vase and cover bearing the London hall mark of 1805-6 (page 87) was made by the King's

decoration found in Pompeii, are purely classical. Note on the neck the disposition of laurel leaves and fruit, quite Graeco-Roman in relief and treatment. Note also the peculiarly Grecian character of Britannia holding a figure of Victory. This is an exceptionally fine piece, showing the great influence which classic forms had over designers at this period. The Gold and Silversmiths' Co. (not to be confounded with the Worshipful Co. of Goldsmiths) have a fine cup, without cover, dated 1825 (George III.), in which the sculpturesque character of some of Flaxman's work is more elaborately shown.

The "Empire" was also based largely upon classic forms, but was largely influenced also by early Egyptian style. Its *appliqué* ornamentation was more applicable to the decoration of furniture, but some excellent effects were produced by those silverware designers who desired to preserve a plain body in their productions and to rely upon strongly modeled outline for the main effect. Thus we find that the sphinx was much in evidence in "Empire" silverware; sometimes as feet, now and again a winged sphinx or griffin was used as a single support to a tea urn or, in a more fitting position, as a knob, button or terminal for the cover. Mask-headed legs with claw feet are another characteristic of this style, while lion's head and ring handles seem almost inseparable from any urn or bowl of this period. The fine centerpiece of Charles X. is an excellent specimen of the "Empire" style, and it will be observed (see cut below) that most of the salient features of the style are introduced in its design. This style, like others, had "transitional" and "pure" pe-

riods, and we find among specimen pieces some remarkable combinations of styles.

Although English artists and craftsmen were responsible for much during the 18th century, it is the French designers of the period who are largely responsible for the styles which linger in the memories of the



SILVER SOUP TUREEN. FRENCH. XVIII. CENTURY.

silversmiths, Rundell & Ridge, after a design by Flaxman. It is essentially classic in character. The shape of the body, the acanthus decoration on the foot, at the base and on the body also, the wave decoration on the shoulders, together with the running floral ornament, which is all of a piece with

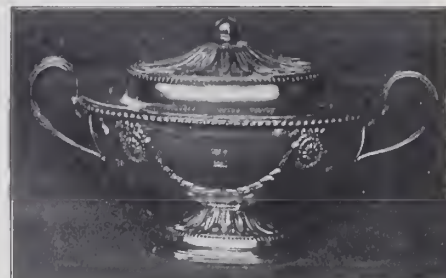

OVAL SAUCE-BOAT AND COVER. LATE XVIII. CENTURY.

silversmiths of to-day; indeed, the many surprises which the 18th century provided in the design of silversmithing had maintained a strong hold until the end of the 19th century. While, however, England and France were, so to speak, always looking for something new, Germany has kept tight to her traditions and, in a way, benefited.

The late Georgian period, the reign of William IV., and the earlier portion of the Victorian era, are characterized as "Late Georgian" by some and as "Early" and "Late Florid" by others. I think the latter designations are the better, since floral forms, sometimes conventional, often rather realistic, were much in evidence. But there



CENTERPIECE OF CHARLES X. STYLE. FRENCH. 1826.



"MILTON" SHIELD, BY MOREL LADEUIL. ENGLISH. MIDDLE XIX. CENTURY.

CHAS. F. WOOD & CO. DIAMONDS

1 Maiden Lane

NEW YORK

Q OUR COMPLETE STOCK
CONTAINS EVERY SIZE OF
ALL THE BETTER GRADES. WE
CAN SUPPLY ANY IMMEDIATE
NEED THE SAME DAY WE
RECEIVE YOUR ORDER.

is nothing particularly distinctive in the productions of this kind except their ornate overdone decoration. They are generally lacking in artistic quality and not infrequently are strange conglomerations of the worst features of the different styles which had been fashionable during the previous century.

This long period, of almost 50 years, was not entirely barren of results, for in both England and France some good work was being produced. But it is significant that while in the two previous centuries large



"PEAR SHAPE" TEAPOT.
LONDON. 1785.

quantities of good domestic silverware was produced, practically nothing new, and only copies at best, of 18th century objects were made. There was a little awakening at the time of the Great International Exhibition of 1851, and a few good pieces were shown by the two neighboring nations of England and France, but these were "show pieces" got up specially for the occasion. The centerpieces on page 89 gave an idea of the wooden character of some of the *chef d'oeuvres* exhibited by British firms, by a French silversmith, the famous Froment-Meurice. The French silver center orna-

ment transitional period a style exhibiting those fine points which must appeal to the man of taste and—the art craftsman.

In conclusion I will give a few notes as to the history and character of silver articles of every-day use.

Salts have been treated in a remarkable variety of ways, and have been designed as carefully and made as ornamental as the most scrupulous could desire. There is a beautiful example of an Elizabethan "standing salt" in the Victoria and Albert Museum. It is rather lavish in ornamentation, but this does not interfere with the beauty of the shape. Other standing salts of this period have steeple tops like the elegant

shaped like an hour glass (there is a fine specimen at New College, Oxford, dated 1493, and another at Christ's College, Cambridge, dated 1507), or a bell, or drum-shaped with elaborately moulded foot and lid, but all tall and upright. But there were



TEAPOT. LATE XVIII. CENTURY.



SILVER TEAPOT. ENGRAVED. LONDON HALL-MARK. 1789-90. SILVER STAND. HALL-MARK, 1796.

exceptions to this rule, for salts sometimes took the form of a squat cup and cover. These were followed by the coverless "Trencher salts" in the reign of Charles II. and were circular and hexagonal until the time of Queen Anne, when they became octagonal.

At the end of the 17th century narrow-waisted salts were in evidence (a revival of the style of the early 16th century), with arms on either side to support the napkin which kept the salt covered and clean, for metal covers had gone out of fashion. The salts of the 17th century were generally large octagonal plates, with a well to hold the salt, being raised from the table by a plain, squat hour-glass stand, a forerunner of the smaller, simpler forms which came into fashion in the 18th century. The forms which are most used now are those prevalent in the latter part of the 18th century. I give three rough sketches to show

cups which charm one by their graceful contour. Of quite a different character is the magnificent gold salt by Cellini which I have already referred to. These handsome heavy salts had a *raison d'être*, for in the old days servants and dependents sat "below the salt" and the head of the house with family and guests sat "above the salt." It was consequently an important item on the table in the 16th and 17th centuries; indeed, it was the most important evidence of the nobleman. We have salts of this period,



RARE GEORGE II. SILVER COFFEE POT. MIDDLE XVIII. CENTURY.

ment by Christofle, of the epoch of Napoleon III. and the fine English silver shield ("The Milton Shield") by Morel Landeuil shows the style of the third quarter of the 19th century, and here I think we may leave this survey of the influence of style on the craft of the silversmith, for the last 25 years have shown a tendency to revert to the traditions which animated the smiths of the 15th century.

This much, however, is certain, that the spirit which is now moving all interested in the applied arts is the right one, and that ere long we shall see evolve from the pres-



SILVER TRAY IN REPOUSSE. GERMAN. XIX. CENTURY.

2 Tulpstraat, Amsterdam

26 Rue Leys, Antwerp

DIAMONDS

WM. I. ROSENFELD

1 MAIDEN LANE

NEW YORK

the "Adams" style, the "pierced gallery" salts, which became fashionable in 1730, and the circular basin shape with gadroon edge and lion's head and claw feet copied from a specimen marked 1798, but which is a resurrection of a type prevalent between 1727 and 1760.

Teapots and coffee pots date from the latter part of the 17th century, and in this connection it is worth recording that the first coffee house was established in England at Exeter by a Jew—one Jacob—and that the first in London was opened in 1652 by an Armenian named Pasqua. The earliest known coffee pot dates from the reign of Charles II, and a teapot is also in existence which dates from that time. Coffee pots made at the end of the 17th century and the beginning of the 18th century were tall, plain and straight sided, sometimes hexagonal in form with domed covers, and the spout placed at right angles to the handle. At the end of the George I. period the spout was placed opposite to the handle, the position mostly favored since then for coffee

fitted on a base. This was followed by the pear shape which became fashionable in 1749, and was later inverted, as the sketch of a 1785 teapot shows, but a number were made octagonal, polygonal or cylindrical, while in the early 19th century this same pear shape form, only very ornate, was much in evidence. At the latter part of the

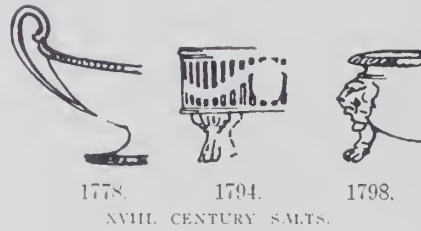

18th century oval, flat, fluted teapots became fashionable. Paul Storr introduced the melon-shaped teapot. When Queen Victoria came to the throne they were of the shape we now call "fluted."

Cruets were introduced in the reign of Queen Anne. Centerpieces were introduced also in the reign of George I. They were

intervals. During the second half of the century the flat surface was frequently engraved, and toward the end flat chased—a much less satisfactory form of surface decoration. Pierced sunk gallery borders were made from the beginning of the reign of George I.

Tea trays were introduced early in the 18th century, and have most of the characteristics of contemporary salvers, but generally rather ornate handles.

Bread and cake baskets were first made during the early part of the reign of George II. They were mostly oval in shape, with pierced bodies and ornate handles. In the reign of George III. the shapes began to vary, and oblong and other shaped bodies were introduced. During this reign baskets for the same purpose, but rather more shallow and without handles, became fashionable. Paul Lamerie made some fine specimens.

Vegetable dishes, with and without heaters, were made during the reign of George I. Entree dishes were introduced in the



EWER OVIFORM. ITALIAN. PRIOR TO 1560.



SILVER APPLIQUE. LOUIS XV.

first very low and later arranged with tiers, while in the early part of the 19th century cut glass was used in making the finments.

Salvers of the Charles II. period were decorated with growing flowers, and animals were sometimes introduced. In English specimens of this time the edge is left plain, but German and Flemish frequently



EWER. ITALIAN. 1560.

pots except those used by French and Italian restaurant keepers. With the advent of George II. the shape of the coffee pot was altered, and it was made with a bulged body which tapered slightly upward and was fitted on a base, but there is in existence a conical-shaped pot of this period. In the reign of George III. the oval urn shape predominated, and a certain fluted urn-shaped pattern is fashionable to this very day. Tea and coffee sets or services were not made to match until the reign of George II.

Tea was introduced into England in 1664 (a fatal innovation when we remember the colonial tea tax riots, the incident of Boston Harbor, which later sent Paul Revere on his ride to Lexington. But before this time Bess of Hardwicke, Countess of Shrewsbury, in "a note of my plate" mentions a "teapott." In the reign of Queen Anne teapots were, together with the necessary accessories, ewers and sugar basins, made in great numbers. The Queen was fond of tea, and helped to strengthen the fashion of drinking it. The earlier form of teapot was circular with a flattened bottom, or a globular form



SALT AND PEPPER STAND. FRENCH. EARLY XVIII. CENTURY.

have the edge crinkled or crimped, thus giving a fussy effect. Early in the 18th century salvers and waiters were also made square, oblong and octagonal, but invariably, whatever the shape, with moulded edges—sometimes rather plain, with a series of hammered steps, a double step with outside gadroon, or shell modeled or escalloped

beginning of the reign of George II. These dishes were fitted with heaters, but about the middle of George III.'s reign they were first made without.

Sauce boats were first made during the reign of Queen Anne; they were on oval feet, and had handles at either side and spouts at each end. In the early part of the reign of George II. the form with which we are most familiar—boat shapes with three moulded feet and one scroll handle—came into fashion. Toward the end of this reign the oval base was reintroduced, but the single handle remained. Sauce tureens with covers, really miniature soup tureens, were introduced in 1750. Sauce tureens with a tray were first made in the reign of George III.

Mustard pots were introduced in the reign of George I. I think I am right in stating that the earliest authenticated silver mustard is dated 1750. These have all the characteristics of salts made during the 18th century.

In the reign of James I. silver sugar castors, muffinccers and pepper pots for the

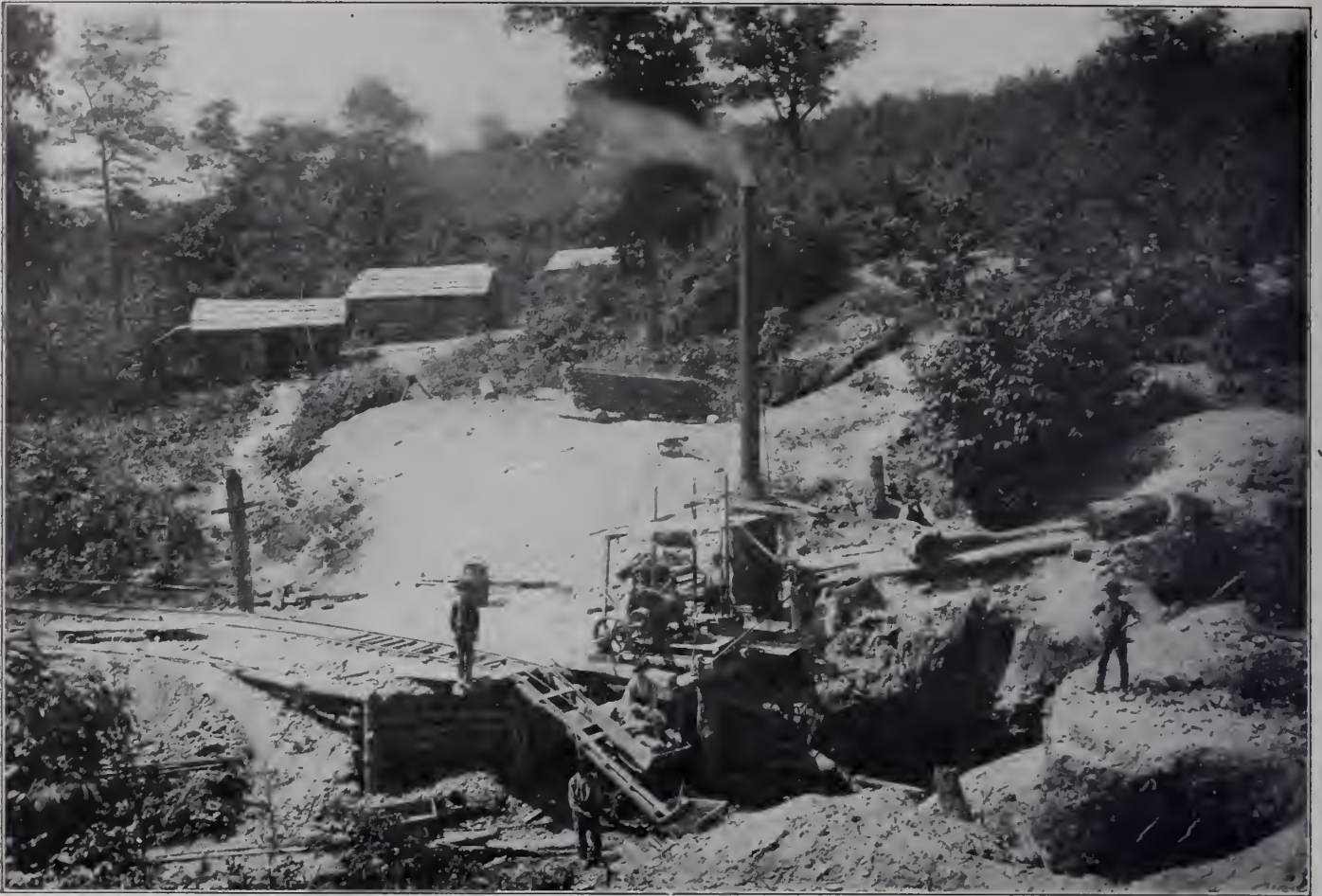

Aquamarine Mine, Mitchell County, North Carolina, Property of the AMERICAN GEM & PEARL COMPANY.

American Gem Cutting

WITH the increase of wealth and its attendant culture the reign of "King" Diamond has been seriously threatened. "My Lady" is not satisfied with a number of diamond ornaments alone—she requires Amethysts and Kunzites, Pink Tourmalines and Pink Topazes, Aquamarines and Green Tourmalines, Peridots and Olivines, Sapphires, Rubies, Emeralds, Topazes, Turquoises and numerous other delicately tinted stones to match her costumes or enhance her particular style of beauty.

☐ The demand for the precious and so-called semi-precious stones has opened great possibilities for the manufacturer and retailer—a brooch, bracelet or chain containing certain colored precious or semi-precious stones that match a costume, becomes an integral part of a lady's dress, and is as necessary as a suitable hat or a pair of gloves.

☐ Among the many stones in vogue none is more beautiful than the American Aquamarines, Tourmalines, Amethysts, Peridots and Kunzites, some of which we mine exclusively and all of which we cut in our New York shop. The list of other American Stones which we cut includes Amazonite, Rose Quartz, Golden Beryl, Thompsonites, Chlorastrolites, Arizona Garnets, Epidote, Californite, Chryso-colla, Etc., Etc.

ONE of the most beautiful and popular of our native gems is the Montana Sapphire—of a bright, clean, electric blue color—this gem is particularly advantageous for the manufacture of moderate-priced jewelry, because of its regularity of shape and color. The demand for Montana Sapphires in desirable sizes and shapes is great, and we are in a position to offer some finely graded stones at reasonable prices.

☐ Besides gems cut from American rough we make a specialty of cutting up fine imported rough, such as Siberian, Uruguay and Brazilian Amethysts, Madeira and Golden Topazes, Persian Turquoise Matrix, Opals—black and in the regular colors, both in gem quality and fine Matrix, Lapis Lazuli and Lapis Matrix, Brazilian Aquamarines, Rubies, Sapphires, Emeralds, Etc., Etc. We cut to the angle of light, and the result is always a brilliant gem, costing a trifle more perhaps than the imported stone, but greatly superior in beauty.

☐ You can freshen up your stock of mounted pieces by substituting new centers of colored stones.

☐ We are ready to figure on the most difficult special orders.

☐ We sell every genuine stone excepting only the diamond.

FROM MINES
TO MARKET

AMERICAN GEM & PEARL CO.
14 and 16 Church Street, - - New York
Corner Cortlandt Street One Block West of Broadway

BUY FROM
THE CUTTERS

purpose of distributing sugar or pepper were particularly fashionable. Cylindrical, also urn and pear shaped forms, were made during the latter part of the 17th century. Hexagon and octagonal shapes appeared during the reign of George I.

Sugar basins and baskets were first designed early in the 18th century. During the reign of George I. they were made like tall miniature cake baskets, pierced or made up of wires, or vase shaped with pierced bodies, invariably with loop-hinged handles at top. With the ascent of George II. the body became boat-like, perched on an oval foot; the handles were still loop and hinged. They were shaped plain, with flutes or engraved, but the pierced urn-shaped bodies were still produced. During this reign was designed the squat form with handles at the ends which has been the traditional basis for sugar basins ever since.

Cream jugs were first used at the end of the 17th century. First low in form, they became vase shaped in the reign of Queen Anne, when they were also first made with three feet like sauce boats referred to above. In the following reign, George I., round-reeded bases were sometimes used, and later three balls or claws sufficed for the base.

Hot water jugs made of silver were introduced in the early part of the 18th century, but were not in general use until after 1760.

Sugar tongs were in use during the reign of George II., but it is difficult to say they were not in use before, as they were frequently unmarked.

Forks are of comparatively modern invention. Queen Elizabeth possessed three, but they were not used and looked upon merely as ornaments. It was actually contended by ministers of the Gospel that it was an insult to God to use forks! The Italian gentleman used forks at the end of the 16th century, but it was not until the middle of the 17th century that English gentlemanly deigned to use forks, and then the fashion progressed very slowly, and it was only at the beginning of the 19th century that forks were considered an essential to the table. The earliest form of English fork had two prongs; this was followed by the introduction of three, and now the fashion is to make all silver forks with four prongs.

Spoons are such ancient articles of domestic use that we need not go back very far in their history, as the older shapes are no longer copies. They are among the most ancient articles of domestic use and are also used for regal and ecclesiastical purposes. The earliest mention of spoons is found in the Bible (Exodus 25-29), when Moses is instructed to make golden spoons for the Tabernacle. Anointing spoons were used at the baptismal functions of the early churches, and we read in the Bible also of the prophet Nathan anointing King Solomon. The spoon used in the British coronation ceremony is said to be 600 years old. Although not now used, Apostle spoons are known to all. They were very popular in the Tudor period—*i.e.*, between 1485 and 1603. In the 16th century the heads of spoons varied in design, and, as well as the "Apostle," were introduced "Acorn," "Seal," "Maiden Head," "Strawberry," "Lion," "Bird," "Ball" and "Shell" patterns. Up to the 17th century the bowl was generally

pear shaped, but it then took a blunt oval form and the head was flattened and bent slightly forward, like the pattern we know as "split end," now quite obsolete. The "Rat Tail" also came into fashion at this time, and at the end of the 17th century (William and Mary) the wavy end was designed, but went out of fashion in 1707. After Queen Anne ascended the British throne the style of spoon which bears her name was designed. The head is rounded and bent forward, and a ridge is modeled down the stem.

The "Onslow" pattern was introduced in the reign of George II., the head being very nicely graven and shaped at the sides and turned back. The "Old English" pattern made its appearance in 1750, and by this time the bowl had become egg shaped—a fashion which has been maintained until to-day. The "Fiddle" is a product of the early 19th century, as was also the "King's pattern."

Teaspoons were not made until late in the 17th century, while dessert spoons were not fashionable until after the Restoration.

Salt spoons were invented early in the last century, as were also coffee and ice cream spoons.

Candlesticks for the table, to hold a candle in a socket instead of on a pricket, were introduced in the 16th century, but the earliest extant known specimen is in the South Kensington Museum, and was about the year 1695. It is composed of a short fluted column, the foot of which fits into a saucer-like depression of a square base. Toward the end of this century more ornate table candlesticks were made, more on the lines of the brass candlesticks common 50 or 60 years ago—only these were like the William III. productions, with flutings on the various mouldings. In the days of Queen Anne the baluster-shaped stem was introduced. In the reign of George III. the well-known Corinthian column candlesticks were introduced, and later the more fitting forms from the design of Josiah Wedgwood. (See page 85.)

A book is now in final preparation by Dr. Geo. F. Kunz, the gem expert, which will treat of jade in its broadest sense, including every phase of mining, artistic manipulation and aboriginal work, in addition to the significance of what the various objects symbolize to the different peoples. A most unique system of illustration will be used by which the book will be brilliantly illustrated. No one has probably paid as much attention to this one mineral as has Dr. Kunz, who is well known as an expert, a collector and a jeweler. He has for the past 20 years devoted much time to a study of jade, artistically, mineralogically and archaeologically. He has visited and is familiar with all the great collections of the world, and has examined in detail the specimens in many museums. He discovered in Silesia, Germany, a mass weighing 4,700 pounds. He has visited the Lake Dwellings and has largely contributed to a number of the great collections of the world. Dr. Kunz had entire charge of the scientific descriptions of the specimens in the Heber R. Bishop Catalogue of Jade, and by special arrangement his own material was withheld and will appear in this new book.

An Artistic Monstrance Presented to the Westminster R. C. Cathedral, London.

A UNIQUE and artistic monstrance which has been the subject of considerable comment in Europe and this country, is now in the Westminster Roman Catholic Cathedral in London, and is the gift of Miss Margaret Stella Nichols, a wealthy young woman of Yorkshire, who converted all her possessions into cash, gave the proceeds to the poor and then became a Nun. Her household silverware and jewelry, valued at many thousand pounds, she had converted into this monstrance, which now enriches the beautiful collections in the Westminster Cathedral.

This fine example of the jeweler's art of the present day, as will be seen in the illustration, takes the usual cruciform shape, the arms of the cross bearing panels in rich translucent enamel of the symbols



AN ARTISTIC MONSTRANCE.

of the four evangelists. Upon the reverse side are panels of enamel showing the childhood of Christ, the Blessed Sacrament, the crucifixion and the ascension. In the center of the cross is the shrine for the Host, which is surrounded by a design worked in diamonds, and is encompassed by a square panel with a design of the vine, while upon the reverse side the wheat is treated. Both are in rich pierced repoussé.

From these springs the flame-like motif symbolizing the spreading of the faith to the four corners of the earth. Encircling the whole is a symbolical rendering of heavenly clouds, jeweled with amethysts. The clouds are pierced with burnished radiating rays, four of which end in crystal pomegranates symbolizing the fruitfulness of the Divine blessing.

The stem is formed of tabernacle work of four niches containing figures, delicately modeled and chiseled, of St. Peter, St. Francis, St. Clare and St. Colette.

Goodfriend Bros.

IMPORTERS OF PEARLS

Sapphires
Rubies
Opals
Emeralds

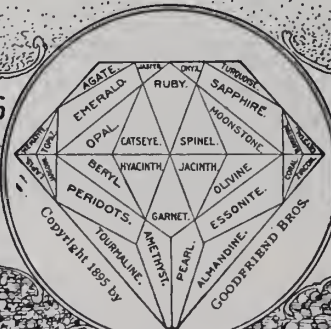

Aquamarines
Peridot
Gem Coral
Tourmalines

and OTHER
Precious and Imitation Stones

PEARL-OPAL-CORAL
& AGATE NECKLACES

PARIS:
10 Rue Cadet.
PROVIDENCE:
212 Union St.

9-11-13
Maiden Lane
NEW YORK

Geo. Brunswick, N.Y.

The Trend of Fashion in Jewelry.

By LILLIAN E. PURDY.

THE predictions for the trend of fashion in jewelry, as indicated in the last anniversary number of THE CIRCULAR-WEEKLY, have been fully realized during the year that has just drawn to a close, and the tendency continues along the line of art. It

and reds and browns, may be successfully matched or harmoniously contrasted. And, with the addition of artistic treatment the jeweler has before him an assurance of success and a healthy, steady business. For, the demand calls for a complete harmony of

merous other stones that had up to this time enjoyed only a mild popularity. It has also brought forward many stones that were formerly useless and has been the incentive for the unearthing of others that were unknown, or that the jeweler had

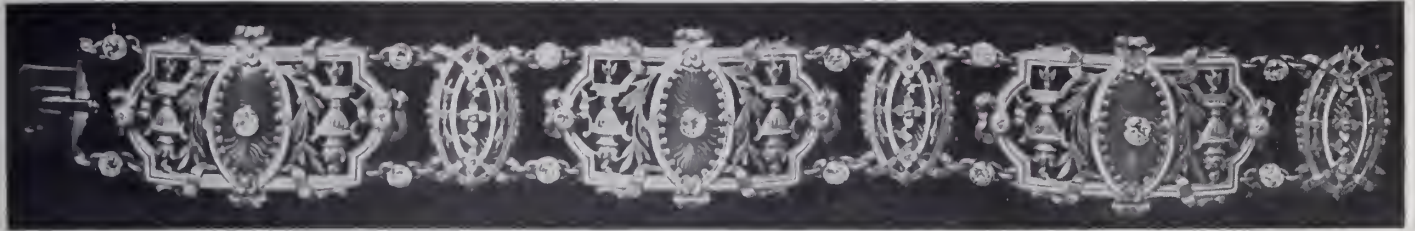

BRACELET, GOLD AND ENAMEL, SHOWING DESIGN FROM PERIOD OF LOUIS XVI. EXACT SIZE.

is, indeed, constantly growing more evident in every branch of jewelry, and notwithstanding the late depression in the business world, the number of new designs wrought out into most artistic creations is surprising and encouraging. The day for the intrinsic value of the materials being the first consideration—that is, the value of single stones and quantity of gold—is passing, and the first consideration is now the art of the production—the design, the quality of workmanship, the touches of color that lend artistic effect. These constitute the primary principles of present-day jewelry, and the jeweler who is successful is the one who is falling in line with the march of progress toward a more perfected art.

There have been several distinct developments that illustrate this tendency, among which the new application of semi-precious stones stands out conspicuously. The infinite possibilities suggested in the fashion for "jewelry costuming," or the matching of fabrics with stones, are evident to the wide-awake jeweler. He will readily realize that in the demand for an ornament to harmonize with each costume, he has the opportunity to sell double, treble, quadruple the number of pieces of jewelry he formerly sold. For, where a woman was once contented with a single article, she now requires several, and even though the stones employed to match the general color scheme may be less expensive, the number of stones and finished articles is greatly increased and the jeweler's opportunities for the display of his art are multiplied almost indefinitely.

With the wealth of mineral material

gown and ornament, both as regards color and design, the gown harmonizing with the ornament and the ornament with



PENDANT DESIGNED AFTER MEDALLION IN THE PALACE OF VERSAILLES.

the gown in such a way that each is but a part of a complete whole.

This, briefly, is the growth in the appli-

never considered at all applicable. Among the odd stones that have come to the fore are the moonstones, chlorastrolite, epidote, heliotrope, opal matrix in several new colors, chiastolite, Thompsonite, azurite, malachite, copperite, rutilated quartz and sun-stones. The stones most in use, however, are the amethyst, tourmaline, aquamarine and kunzite, the latter taking the place of the pink topaz, which is more expensive. These, as well as the others, are usually seen in the facet or brilliant cutting for women's jewelry and in the cabochon cutting for articles used by men.

The newest stone to appear in the market is a black opal. It is from Queensland and has a black base with wonderful flashes of peacock blue, red and green.

Californite is another comparatively new stone of rare beauty. It is a variety of Vesuvianite and is a translucent green peculiarly specked throughout.

Aside from the stones, there is another straw that points to windward in jewelry development, and this consists in a novel treatment of the grape design. As is well known, the grape is not a new theme for jewelry, but it is at present undergoing a revival that is significant since it illustrates the fact that jewelers are now imbued by the same spirit of art here as they are abroad, showing that it is no longer necessary to cross the ocean for the element of art in jewelry—a fact fast becoming recognized by the general public. Again, the designs are noteworthy as they have grown away from the usual bunch of grapes and spray of leaves. The branches and tendrils



BRACELET WITH OPENWORK FLORAL DESIGN. STYLE OF LOUIS XVI.

easily accessible, all the newest shades of dress fabrics, from oyster white and the new shades of champagne to rich plums

cation of stones, and it has opened a new era for the amethyst, tourmaline, topaz, kunzite, aquamarine, peridot, jade, and nu-

have been worked in, forming delicate, dainty conceits in arbor effect. The theme has not by any means been exhausted by

Coral Direct From Fishery to You

*Our own fisheries
in Japan*

*Our own fisheries
in Italy*



Highest Award in all
European Expositions

Highest Award in all
American Expositions

BORRELLI & VITELLI

401 BROADWAY - - - - - NEW YORK

C
O
R
A
L

C
O
R
A
L

Coral Strings

Coral Buttons

Coral Long Chains

Coral, Pear Shape

Coral Cameos in all sizes and colors

Coral, Flat and Round, in all sizes and colors

Coral Cameos in Shell, Pink, Dark and
Yellow, in all sizes

Coral Headquarters

We send memorandum packages to all responsible parties

BORRELLI & VITELLI

3 Via Amedeo
Terre del Greco-Italy

401 Broadway, New York
Telephone, 5412 Franklin

19 Rue d'Hauteville
Paris, France

this jeweler and the designs and materials suggestive of use in working out the ideas are unlimited.

The most strikingly original design, the arbor effect, has been carried out in brooches and pendants. The stem of the vine forms a sort of border, the bunch of grapes being attached at the top, with the

especially the simpler ones in the bangle form, head the list. Others aver that as almost every woman is supplied with bracelets, the demand for them is on the decrease, although they are as fashionable as ever. But the weight of opinion seems to fall toward handy pins, veil pins and pendants.

there is a tendency toward their displacing the necklace, especially the one of festoon effect. There is a variation of the latter in a row of a dozen jade pendants with baroque pearls suspended below. Bars are also

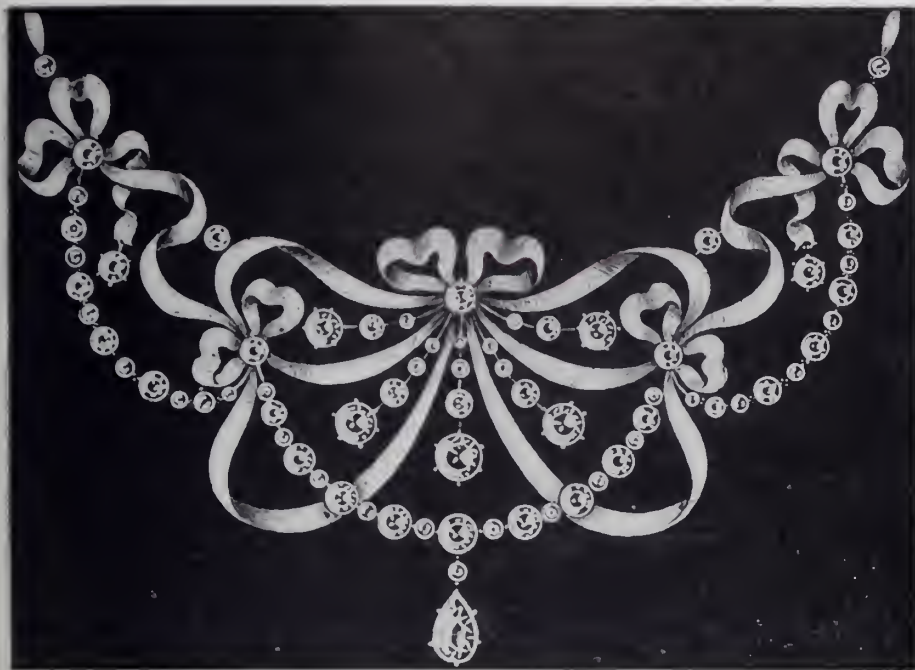

POPULAR STYLE OF RIBBON DESIGN IN NECKLACES.

leaves and tendrils intertwining. The vine and leaves are of platinum set with rose diamonds, and the grapes are pearls arranged in a manner that is consistent with the license of conventionality in art. The designs are well balanced, following nature closely but having that suggestiveness that pertains to all art.

The handy pin is an extremely useful article which may be had in all possible degrees of elaboration or simplicity, and perhaps it may best be given the palm.

Veil pins are almost equally diversified. They come in all sizes, from small pins for the face veil to the long heavy pins for automobile use. The arrow pin, an innovation of last season, holds its own fairly well. The pin in the form of a beetle, butterfly,



TEDDY BEAR DESIGN ON BRACELET.

used in lattice effect, or single knife-edge bars to suspend single stones and pearls.

Enameled effects in necklaces are receiving some attention. The chains (also used in the same designs for watches) are made of enameled links with pearls between. The



A POPULAR PENDANT.

central ornament is an enameled affair with baroque pearls suspended by enameled sections. Red and blue are the principal colors used in this connection.

The jeweler who makes many of these enameled pieces is attempting to revive black jewelry, which is being adopted



A GRAPE DESIGN PENDANT.

The grape design suggests an extensive use for pearls, which have not sold so well this year as they did last. Diamonds have been more in demand.

As to the particular articles for which there has been the greatest sale, jewelers are not agreed. Some claim that bracelets,

pheasant or dragon fly, with a spring by means of which it grasps the veil, has been revived by one jeweler. It is one practical solution of the veil pin problem and is very decorative. Another new style is in the form of a small hairpin with a jeweled top. Thrust through the veil and hat at almost any point, it is both useful and ornamental.

Pendants are growing more dainty and

abroad. There is some question whether the young and those who are not in mourning will take to this innovation with much enthusiasm. As a fad it may have some success, and, in some applications, jet or black enamel is exquisite. It was once considered the only proper background for diamonds, and it certainly is effective with these stones. Where black enameled chains



BUG PINS OF GOLD, RICHLY ENAMELED AND JEWELLED.

LOUIS KAHN

MOSES KAHN

SAMUEL H. LEVY

L. & M. Kahn & Co.

Importers and Cutters of

DIAMONDS

170 Broadway, cor. Maiden Lane, New York

AMSTERDAM: 2 TULP STRAAT

CUTTING WORKS: 29 GOLD STREET

Arnstein Bros. & Co.

Importers and Cutters of

DIAMONDS

65 Nassau Street

New York

LONDON: Audrey House, Ely Place

AMSTERDAM: 6 Tulp Straat

ALBERT LORSCH.

N. Y. Telephone Call, 2161-2 John.

ALFRED KROWER

ALBERT LORSCH & CO.

LORSCH BUILDING, 37 and 39 MAIDEN LANE, NEW YORK

131 Washington Street, Providence, R. I.

CUTTERS OF
DIAMONDS

are used to harmonize with locket, pendants or watches similarly decorated, it is appropriate and attractive.

Jeweled sections on narrow black ribbons for locket and watches maintain a steady favor. They also continue to be used as slides on velvet bands for the neck. As a rule, they are narrow, the buckle being a popular design, but a few are wide. A new one recently seen was in the form of a wide square buckle, the dainty jeweled tracery giving the effect of lace. There was no other section to this ornament, the wide



GRAPE DESIGN BROOCH—PEARLS AND ENAMEL.

velvet fastening with a concealed platinum clasp. The jeweler who made this exquisite ornament, which could not be worn by the woman with a short neck, has also applied these tiny jeweled sections to black velvet for bracelets. It is a novel idea.

This same jeweler asserts that he has sold more rings than anything else. He gives as a reason that women can always find use for an extra ring. He states further that there is a tendency to exchange two moderately good rings for one handsome one. His customers are willing to pay the difference and enjoy the satisfac-

As with bracelets, so it is with combs and barrettes—as nearly every one is supplied, the demand is less marked. With the former, the jeweled or gold engraved effects on carved shell, of medium height, are most frequently seen. As to designs,

As a rule, brooches show less fluctuation than other articles. There is always a demand for them, and there are certain styles that are almost standard. Among these is the large single stone or cameo brooch. It may be surrounded by a plain band of gold,



COMB AND CORSAGE ORNAMENT WITH PENDANT, BY PALIZE

when the Marie Antoinette, Louis XVI. and La Grecque motifs are exhausted, the field has been fairly well covered and all that is left is variations of these designs. La Grecque designs show some want in popularity. The straight lines and square corners admit of limited applications, and

gold engraving, or rows of pearls. Of the latter, a new brooch has three rows of pearls, pegged on, giving a unique effect.

Among the more expensive brooches, the large stone surrounded by a dainty jeweled design is always an available article, and offers a wide range to the designer. Different colored diamonds apply in this connection.

Some of the most beautiful brooches may be seen in one of the exclusive uptown New York shops. They come under the head of "art jewelry" and are in most exquisite dull enameled effect. The cranberry and grape designs, with soft foliage and irregular outlines characterize the collection. One of these designs contains a large water opal in the center with a green gold fish surrounding it and a curious seaweed effect wrought out in dull green enamel. The fish is lightened by tiny pieces of chryso-prase.

Remarkable hair ornaments are also found among these objects of art. They are in floral designs—sprays of spyrea, wild carrot and yellow clover. The color scheme is wonderfully carried out in the dull enamel, with buds of opals or diamonds, or touches of ruby or chryso-prase and crisped foliage in a shade of green that simulates nature to perfection.

Among the novelties to be seen this season is a locket with folding compartments for photographs to the number of from six to 14. The outside is polished gold and the locket may be worn on a chain or a chatelaine.

Another article of note is an engine-turned card case which differs from the usual one in that it opens with a flap which

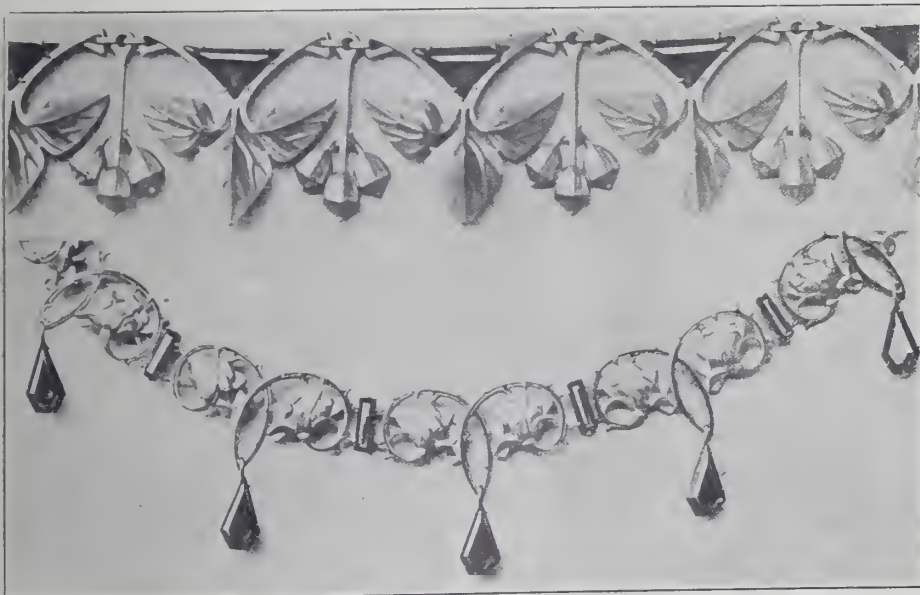

NECKLACES, EXHIBITED AT LAST PARIS SALON, BY L. GAILLARD.

tion of constantly having better jewelry. In the making of these rings, either sapphires or emeralds with diamonds are most in demand, and the design most frequently follows that of the large central stone surrounded by caliber diamonds.

they appeal to the taste of fewer people. Barrettes are daintier in design. They are, of course, limited as to weight, as are also the combs, and require a certain simplicity. Pearls are specially applicable to barrettes.

EDUARD VAN DAM

CUTTER OF

DIAMONDS

CUTTING SHOPS:

ANTWERP

41 Rue de la Province (Sud.)

CABLE ADDRESS, MADNAV

NEW YORK

437-439 Fifth Ave.
Cor. 39th St. Knabe Bldg.

TELEPHONE, 5879 39TH ST.
CABLE ADDRESS, DEVRIVAN

AMSTERDAM

55. Ruysdaelstraat

CABLE ADDRESS, MADNAV

LONDON OFFICE, 22 Holborn Viaduct

THE HERMAN KECK MANUFACTURING CO.

CUTTERS OF

DIAMONDS

19-21 WEST FOURTH STREET

CINCINNATI, OHIO

Oppenheimer Bros. & Veith,
Cutters of Diamonds,

65 NASSAU ST. (PRESCOTT BUILDING), NEW YORK.

AMSTERDAM,
2 Tulip Street.

LONDON,
40 Holborn Viaduct.

CUTTING WORKS,
Cor. Union & Nevins Sts., Brooklyn.

MEYEROWITZ BROS.

IMPORTERS OF

DIAMONDS

PRECIOUS and
SEMI-PRECIOUS STONES

ESTABLISHED 1896

NEW YORK: 37-39 Maiden Lane
PARIS: 58 rue de Maubeuge
AMSTERDAM: 2 Tulpstraat

MEYEROWITZ
BROS

MEYEROWITZ
BROS

is fastened by means of a cabochon saphire clasp.

A gold bouquet holder is a useful trinket. It is pinned to the dress and there is a piece of gold that slips around the stems of the flowers and is firmly caught in an opening made for the purpose.

There is a card case for men that has a convenient little spring by which the card may be pushed from the case so that it is easily grasped.

Woven gold bags are more shirred than

Artistic Jewelry as a Feature of the Cover Design—Original Jewelry Illustrated.

BINDING this, the 39th Anniversary Number of THE CIRCULAR-WEEKLY, we offer what we believe to be the most beautiful and artistic as well as the most appropriate cover design that has ever appeared on a journal devoted to this craft. Essentially it is composed of two peacocks, who from their bills hold the ribbon from which is suspended a magnificent pendant

sign. Transparent enamel is used as a background and gives to the whole piece a soft and refined tone.

The reproduction of this design is an exquisite specimen of modern four-color work. It was engraved and printed by the J. W. Pratt Co., New York, who are eminent in their line.

The artist who designed the cover has also drawn the illustrations used on the front page of this issue, which are original designs of jewelry of the highest artistic type and are offered to the trade at large by THE CIRCULAR-WEEKLY for general use either in their original form or with modifications desired. As is usual in such productions, the character of the stones is the factor determining the character of each piece. In the brooch, for instance, the design is made to suit the cut of the center stone, a dark green tourmaline, and has for its *motif* the Egyptian Sphinx. The mounting is executed in green gold and has a special cut tourmaline as the drop.

The center design shows a gold pendant in modern style, and in this the iris forming the center is in a delicately colored tint of enamel. Sapphires and pearls are freely used and give a distinct character to the whole piece.

The two other designs are shown. In the brooch on the right, the mounting of which is made in platinum set in diamonds, an oval set in sapphires in caliber cut is used as a center, surrounded by a delicate wreath of sapphires of flowers and leaves. The design of the pendant on the left is distinctly along the lines of the Empire style. The mounting is also in platinum and is set in diamond and caliber cut emeralds.

Neglect of Flaxman's Grave Deplored.

WRITING to the *Benden Pottery Gazette* from St. John's Wood, Algonnon Ashton says: "Happening to be passing the old, long since disused burial grounds of St. Pancras and St. Giles last Friday afternoon, I thought I would go and have a look at the grave of John Flaxman, and see in what sort of a condition it was, remembering that some 16 years ago I caused the resting place of England's greatest sculptor to be restored. Imagine my dismay to find Flaxman's tomb in a far worse state than it ever was before! Not

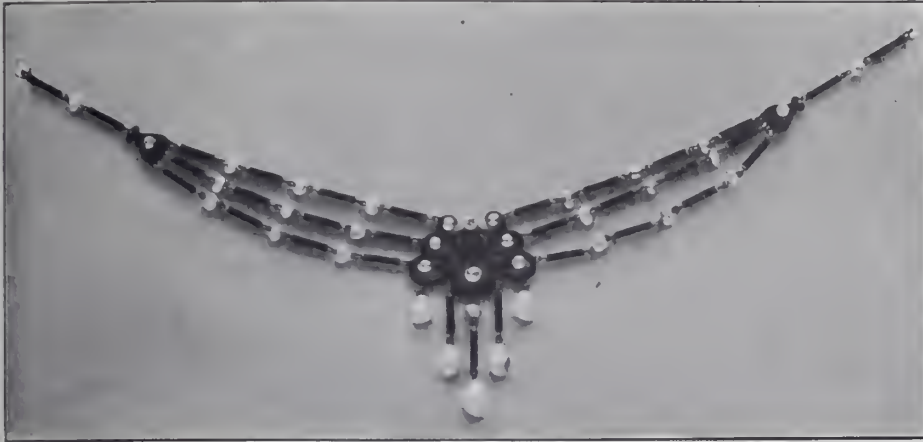

NECKLACE OF BLACK ENAMEL AND PEARLS.

ever. An extremely handsome one has a festoon design of jewels across the bar, the festoon falling down a space on the bag.

Notwithstanding the strenuous efforts of some of the jewelers and fashion makers, earrings have not reached as wide popularity as they enjoy in England. The large single pearl earring, or the pearl surmounted by a diamond, is a sort of standard article, but Americans are not quick to adopt the French ideas in this line. Some of the jewelers, however, still firmly declare, "They're coming, they're coming." And it remains to be seen whether this year will see their general adoption.

The jeweled and richly enameled watches continue a moderately steady sale. There is little demand for the bracelet watch, which has a rival in the new finger watch that is attracting some notice. These are so daintily constructed that they do not look awkward, as might be supposed, even on a slender hand. They may be had in plain gold, beaten, engraved or gem-

of gems, and though simple in detail the entire effect of the drawing and the color scheme is both unusual and beautiful. The peacock, which is universally associated with the idea of dress and ornamentation was used extensively by the old masters as



A COMB OF MODERN STYLE.

a symbol of stateliness and beauty as well, and as represented here forms a fitting support of the beautiful pendant which embodies the latest ideas in perfect jewelry work in combination with enamel.

As the artist who drew the cover, Hans Brassler, is a noted jewelry designer and



BRACELET SHOWING CAMEO HEADS OF LADIES OF COURT OF LOUIS XVI. AND FLOWER DESIGNS OF SAME PERIOD.

studded. Of course, they represent a fad which may or may not prevail to any extent.

For some of the illustrations as well as some of the facts and descriptions in the foregoing article, we are indebted to A. J. Hedges & Co., Chester Billings & Son, Ludwig, Nissen & Co., Alling & Co., and others, to whom we extend our sincere thanks.

practical manufacturer (being head of the Hans. Brassler Co., Newark, N. J.), the pendant is delineated in a way that makes it possible to reproduce it at once from the illustration. The material used for the framework of the piece is platinum, which is set with diamonds and sapphires in caliber cut. The lilies shown are of delicate cut enamel and form the motif of the de-

a word of the long inscription could be deciphered, and the neglect of the whole family burial place was simply awful.

"What can the descendants of the illustrious John Flaxman be thinking about?" asks Mr. Ashton, in indignation at the conclusion of his letter and his question will find an echo from other admirers of the great artist.

Not One Stone

has ever come near attaining the popularity of the Reconstructed Ruby—the Hope Sapphire following next. * * * Comparatively inexpensive, these two Gems are within the reach of all, their demand increasing rapidly with their introduction to the general public. * * * We have realized that these Scientific Gems are articles that have come to stay, and have accordingly equipped ourselves for their uninterrupted production. Our facilities for cutting these stones enable us to fill all possible orders without delay.

L. Heller & Son

Importers of Precious and Imitation Stones
68 NASSAU STREET, NEW YORK

PARIS
39 Rue de Chateaudun

PROVIDENCE
212 Union Street

IDAR
14 Hauptstrasse

RUDOLPH NOEL

PHILIP NOEL

RUDOLPH NOEL & CO. IMPORTERS AND CUTTERS OF DIAMONDS

2 Tulp Straat, AMSTERDAM

37-39 Maiden Lane, NEW YORK



1319

SPRING FLOWERS ARE COMING!



1348

So are our new baroque pearl flower pieces shown herewith. They are beautiful and are somewhat different from our other baroque pearl flower jewelry now on the market. We get these baroques from a small western river heretofore unexplored for pearls until recently and we expect to have two men on this river this coming summer gathering these pearls for us exclusively, so we shall be able to supply the demand which will be large, judged by the great demand for the daisy and chrysanthemum flower pieces which we make.



563

Crossman Company

No. 3 MAIDEN LANE
NEW YORK



580

Gold and Silver Treasures of the Royal House of Hohenzollern.

By H. Sandahl.

GR^{EAT} interest always attaches to the possessions of royalty, especially such ones as belong to the realm of art; and the best and choicest artistic treasures produced at any one period have usually been acquired by the reigning families, either as gifts or in other ways. The contemplation of these is instructive and gratifying alike to the layman and the artisan.

Among the gold and silver treasures owned by the crowned heads of Europe, the Hohenzollern collection interests the jeweler, the goldsmith and silversmith to no small degree, containing, as it does, much material capable of furnishing him with excellent ideas for his own designs.

Thanks to the efforts of the committee in charge of the recent German goldsmiths' convention and celebrations, called *Goldschmiedetag* (goldsmiths' day), the participants in this festival were allowed a glimpse of the guarded treasures belonging to the kings of Prussia, now also emperors of Germany. Many declared this the crowning event of the meeting, and one can find no fault with this decision. The following is an account of the impressions which one of the party received on the occasion of the inspection, and as he is a practical silversmith, his observations are valuable. "For me," says our informant, "as to every other participant in this visit to the treasure chambers of the Prussian royal house, the memory of what we saw will be ineradicable, and will in many respects influence our standards. I consider the occasion extremely useful to the worker in precious metals."

First, the reception rooms of the royal palace and the apartments dedicated to public occasions were visited, and this afforded the opportunity of seeing a large number of the best pieces of work from the Middle Ages, done by masters in Augsburg, Nuremberg and other cities. On account of the many specimens of later periods and greater importance, still to be

viewed in the other rooms, it was not possible to give special attention to the separate pieces, although all the antique treasures have for goldsmiths great historic value, and should be stimulating even to the art of to-day. Among the work of later date, the visitors noticed the enormous chandeliers, 2¼ meters in height, with an accompanying table centerpiece, a



CLOCK OF SILVER, GILT, ONYX AND ENAMEL, OWNED BY EMPEROR WILLIAM.

wedding present to Emperor Frederick.

The party now passed on to the room containing the Prussian crown jewels. Crowded into a dark passage-way, advance seemed for a time impossible, but "at last," says the narrator, "the insignia of the crown lay before us. Here was the royal Prussian crown* itself. Reverentially I took in

*The royal crown must not be confounded with the crown of the German Emperor, which so far only exists in the shape of a design, the original crown of the old German Empire being preserved in Vienna.

my hand this symbol of the highest dignity, but its weight was more than I should care to carry very long, and I can easily believe that such a crown is literally a heavy burden." It is not, he says, as richly decorated with gems as he had imagined it, but still contains a great number of large and wonderfully beautiful rose-diamonds of the purest water. The scepter is completely covered with precious stones, all, of course, cut in old style. At the top is a large sapphire, pierced, unfortunately. Two swords with richly ornamented sheaths complete the emblems of the highest citizen of Prussia. One of these, the "Imperial Sword" of Prussia,

is illustrated on page 113. On the hilt appears the medallion portrait of Margrave Albrecht and his spouse. On the sheath are Biblical scenes, and ornaments in the Nuremberg style. It is almost one meter long, and was made in Nuremberg in the 16th century.

"Still more than by the crown jewels," continues the jeweler, "was my attention chained to a number of truly wonderful snuff boxes, mostly of colored agate, and set with diamonds and colored stones in most fascinating style. One gazes at these in a mazed admiration, and I, for my own part, was so absorbed that I entirely failed to hear the explanations of our guide with regard to them."

Owing to the size of the party the silver treasures in the first rooms were exhibited to quite large groups of persons, and we have only an approximately accurate description of these. But the following objects were especially noted:

In the first of the seven rooms which contain the silver was a collection of porcelain, showing samples of all the china sets in the different royal palaces. Of special in-

terest were several plates from the time of Frederick the Great, almost entirely gilded. They are said to be worth more than 100 marks each. The great monetary value represented by the china which belongs to the royal palaces can be guessed at from the fact that the services are kept complete to the extent of accommodating 800 persons; and in this room were to be seen, as said above, samples of all the sets, arranged in cupboards in the walls. In the second room are the silver dishes, of which an astonish-

REGISTERED



TRADE-MARK

AMETHYST JEWELRY

REGISTERED



TRADE-MARK

We have many beautiful and striking pieces in amethysts and combinations of amethysts and pearls, and amethysts and diamonds.

The popularity of amethyst jewelry makes this exceptionally salable stock, and you should certainly have a few representative pieces.

We carry Rings, Necklaces, Brooches, Scarf Pins and La Valliere.

If you have our catalog, well and good—If you haven't, send for it.

HAYDEN W. WHEELER & CO., Importers
2 Maiden Lane, NEW YORK, N. Y.

REGISTERED



TRADE-MARK

AMSTERDAM, 2 Tulp Straat

'Phone 7365 Cortland

LONDON, 50 Holborn Viaduct

REGISTERED



TRADE-MARK

F. A. JEANNE

FANCY COLORED AND FANCY SHAPED

BLACK OPALS

5 Square de l'Opera PARIS, FRANCE

Cable Address

"GEMFINDER"

Western Union Code



When A 

Customer Wishes



To Sell

YOU any lot or single piece of mounted diamond jewelry—large or small—do not turn him down absolutely, send the goods to me for a

SPOT CASH OFFER

and save all trouble and worry. I pay all express charges and insure the goods in transit. I have been in the business right here for 16 years, and can give the very best references as to responsibility on application. Offers and valuations furnished promptly. Write for further information.

J. J. COHEN
1011 Chestnut St.
Philadelphia, Pa.

Established 1891

ESTABLISHED 1872.

E. HAHN & CO.,

33, HATTON GARDEN, 33
LONDON.

CABLE ADDRESS:
 "AQUAMARINE," LONDON.

Precious Stones, Semi-Precious Stones, Ceylon Fancy Stones, Pearls, Corals, Opals and All Novelties in Stones suitable for	}	I. All Jewelry and Export Purposes. II. Art Metal Work, Church Work. III. Mechanical Purposes. IV. Collectors, Educational Purposes, Museums.
--	---	--

GARREAU & GRISER

68 & 70 Nassau St., New York

LAPIDARIES. PRECIOUS STONES

GEMS in Unique Cuttings

R., L. & M. FRIEDLANDER

IMPORTERS OF

DIAMONDS

30 MAIDEN LANE, - - - NEW YORK CITY

ing number are exhibited. There is one plain solid silver service for 600 persons. Most of these dishes are in simple style, the plates, etc., smooth with soldered grooves.

In the third room the attention was first



PIECES FROM A SILVER DESERT SERVICE.

attracted to the regatta prizes of the present Emperor, placed in the center of the table; also to a centerpiece of mighty dimensions. This latter piece, as well as an embossed shield in the wall cupboards, beautifully chased, were made in the



ARM CHAIR MOUNTED WITH EMBOSSED SILVER, USED AS A PRUSSIAN THRONE. EARLY XVIII. CENTURY WORK.

Kunstgewerbeinstitut, for the occasion of paying homage to Frederick William IV. in 1841. A table decoration in the form of a silver galley was brought from China by Prince Henry of Prussia. This is described as being worked out in the smallest

details with the greatest care and neatness. Two large rococo candelabra, from the reign of Frederick the Great, are mentioned; also 36 richly gilded and engraved plates belonging to the same period. It would be impossible, our informant says, to mention separately all even of the principal objects of interest; but no artisan, he adds, will pass the cupboard containing the wonderfully embossed dishes and coffee trays without pausing to look again before being carried on by the crowd. Near the entrance

cup is of Augsburg manufacture, similar to one exhibited in the Berlin *Kunstgewerbemuseum*. A *Speisglocke* (covered dish) of Frederick the Great is of historical interest. On a side table are a number of richly decorated goblets and other objects, both old and new, the most noticeable among them being a solid gold box, a wedding present from the Emperor of Siam. A baptismal gift to the present Emperor is a goblet, richly ornamented with gems. A solid gold cup, executed by Hermeling, was



MAGNIFICENT SILVER GOBLET. PARTLY GILT WORK, COLORED ENAMEL AND GEMS.

to the next room is a pair of solid silver candelabra, colossal in size.

The visitors imagined themselves nearing the end of these treasures, but the fourth room was the beginning of the real masterpieces of art. Here are a great number of all kinds of vessels, cups, goblets, etc., and only a few can be named. An epergne of unique design was a present from the Queen of England. A large collection of coin cups aroused the question how it was ever possible to solder in all the coins. The work must surely have required much skill and labor. One large

perhaps a gift from the Rhine provinces. One goblet represents the fortress of Sigmaringen. In a side cupboard are to be seen, besides many cups—regatta prizes, etc.—all kinds of small objects, among them a pair of massive candelabra, from a design by Professor Stier.

Impressions were crowding one upon the other, till it seemed as if no more could be received; yet the fifth, sixth and seventh rooms were yet to be seen. Two striking objects were noted in the fourth room—epergnes, presented by the Sultan of Turkey and the city of Constantinople. Over

WM S. HEDGES & CO.,

IMPORTERS AND CUTTERS OF

DIAMONDS.

Precious Stones and Pearls.

170 Broadway, Corner Maiden Lane, New York.
27 Holborn Viaduct, London.

R. C. SAUNDERS, Pres.

W. V. LAURINO, Vice-Pres.

JOSEPH P. MEURER, Treas.

SAUNDERS; MEURER & CO.CUTTERS AND IMPORTERS OF **DIAMONDS** AND OTHER PRECIOUS STONES

FINE PEARLS AND FANCY GEMS

65 Nassau St., Cor. John St., Prescott Building
Telephone, 1613 Cortland New York

EMERALDS, DIAMONDS AND PEARLS **CABLE ADDRESS: MILBAGG**

BAGG, PERINE & CO.
IMPORTERS
452 FIFTH AVENUE, at 40th Street
(Formerly at 21 MAIDEN LANE)
NEW YORK

TELEPHONE NUMBERS: 917-918 BRYANT **RUBIES AND SAPPHIRES**

GEORGE H. HODENPYL.

WALTER N. WALKER.

HODENPYL & WALKER

IMPORTERS OF

DIAMONDS

OTHER PRECIOUS STONES AND PEARLS

MANUFACTURERS OF FINE DIAMOND JEWELRY

373 FIFTH AVENUE, NEW YORK

Corner 35th Street

Telephone, 5093 Madison Square

EISENMANN BROS.

IMPORTERS OF

Pearls and Precious Stones**452 Fifth Avenue, New York**
cor. 40th St., Knox Building

3 Rue St. Georges, Paris.

Ludwig Nissen & Co.182 and 184 BROADWAY
NEW YORK**PEARL****NECKLACES**

AND

DIAMOND**COLLARETTES**Mounted Diamond
Jewelry of Every
description :: ::Largest assortment
of all kinds of very
fine, fancy and rare
gems, including
Pearls, Diamonds,
Emeralds and
Sapphires :: ::**PARTICULARLY
FANCY COLORED
AND FANCY
SHAPED DIAMONDS****Ludwig Nissen & Co.**182 and 184 BROADWAY
NEW YORK

the door is a vessel as large as a medium-sized cask, made of 850 thaler pieces, soldered together. This room also contains Queen Louise's golden toilet set.

In the fifth room were seen the wedding presents from cities, provinces, etc., to the present Emperor. Here, in the opinion of the person giving the description, is the work which is really of the greatest artistic

pedestal rises a round shaft, at the foot of which sit two figures, those of a Roman emperor, representing masculine strength, and of a lovely and beneficent goddess, symbolizing feminine gentleness, carrying flowers and ears of grain. Garlands of myrtle and roses join the two figures.

Next we show (page 109) a magnificent goblet, silver, partly gilded, shaded and

The cut on page 109 shows a specimen from a dessert set, consisting of plates, spoons, knives and forks for 50 persons, of silver, entirely gilded. Its decorations follow the form of the large table service which was the gift of the Prussian cities, and which in its turn is based upon the style of the silver belonging to the royal palace in the time of Frederick I. of Prussia. On the edge of the plates, shaped into six curves, are three panels, with crowns and the united monograms of the royal pair, joined by infantile figures, masks and garlands of flowers. The knives and forks are also decorated with the monogram. These show the form which must necessarily be used for a completion of the service with knives and forks.

The cut on this page depicts a handsome epergne, which rests upon a pedestal, ornamented with projecting scrolls, dolphins' heads, masks, etc. Two Tritons, male and female, bending over far backwards, hold two shell-basins for flowers, between which



HANDSOME EPERGNE, SHOWING ARTISTIC FIGURES.

value. In the other rooms the visitor had seen, for the most part, the work of the past, which, to be sure, has for the jeweler a certain value aside from its historic worth; but here he finds himself in the present, and the sympathetic interest awakened by the achievements of modern art is heightened by the fact that all the designs for these gifts have a common origin—they are from the fertile brain of Councillor Adolf Heyden and were executed by the famous Berlin court silversmiths, Sy & Wagner. Thus the room forms, in a sense, a complete whole.

We present to our readers illustrations of the most interesting of these pieces. A closer description of these treasures is of absorbing interest, and we give it herewith.

On page 107 is a gorgeous clock of silver, partly gilded, shaded in different colors and oxidized, the core-pieces of Oriental onyx, many details in enamel, with colored stones and pearls. On the oval pedestal are two shields with armorial bearings, and a dedicatory inscription, surrounded by cornucopias, garlands and cherubs. From this

oxidized into different colors, with colored enamel and various kinds of colored stones. The pedestal, curved and four-sided, has the arms of the province of Saxony; three of these and the dedicatory inscription are on shields, supported by four figures of dragons, standing out strongly. Between, are masks and clusters of fruit. The cup is removable; on the body of it is represented, in the fashion of a frieze, an old German wedding procession. Bread, wine and fruit are being presented to the bridal couple by children and maidens, the parents follow, and the procession is closed by dancing couples and musicians. Above is a quotation from the old German poet, Walter von der Vogelweide:

*"Minne sei nicht einsam,
Sie soll sein gemeinsam,
So gemeinsam, dass sie dringt
Durch zwei Herzen und kein drittes zwingt."*

On the cover are the arms of the royal couple, crowned with roses by Cupid, Psyche and Hymen, swinging his torch. On the finely curved handle is the figure of a herald.



DECORATIVE PITCHER, FORMING PART OF TABLE CENTER.

rises the pedestal supporting the upper group of figures, set with armorial bearings. There is a companion piece to this. The principal group of the first epergne consists of a bearded Triton, who has caught hold of a young, almost nude female; the latter bears high upon her shoulder a large trumpet-shaped shell, intended to hold a tall bouquet; the figure of a child with a

ABEL BROS. & CO.

64-66 John St., corner William St.

Abel Building, TRADE  MARK. NEW YORK

Branches at LONDON—PARIS—AMSTERDAM—ANTWERP—IDAR—OBERSTEIN
 DIAMOND MOUNTED JEWELRY—FINE DIAMOND MOUNTINGS—LOOSE
 DIAMONDS, PEARLS, RUBIES and SAPPHIRES
 ORIGINAL DESIGNS

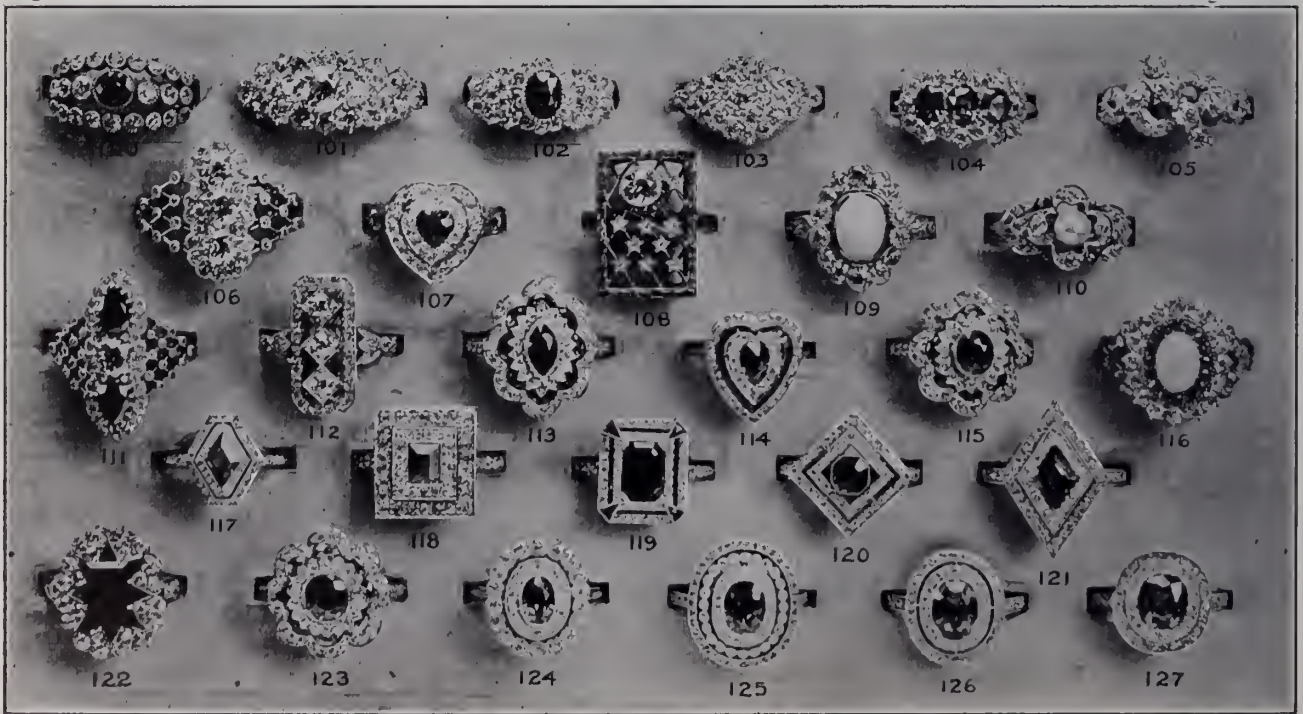
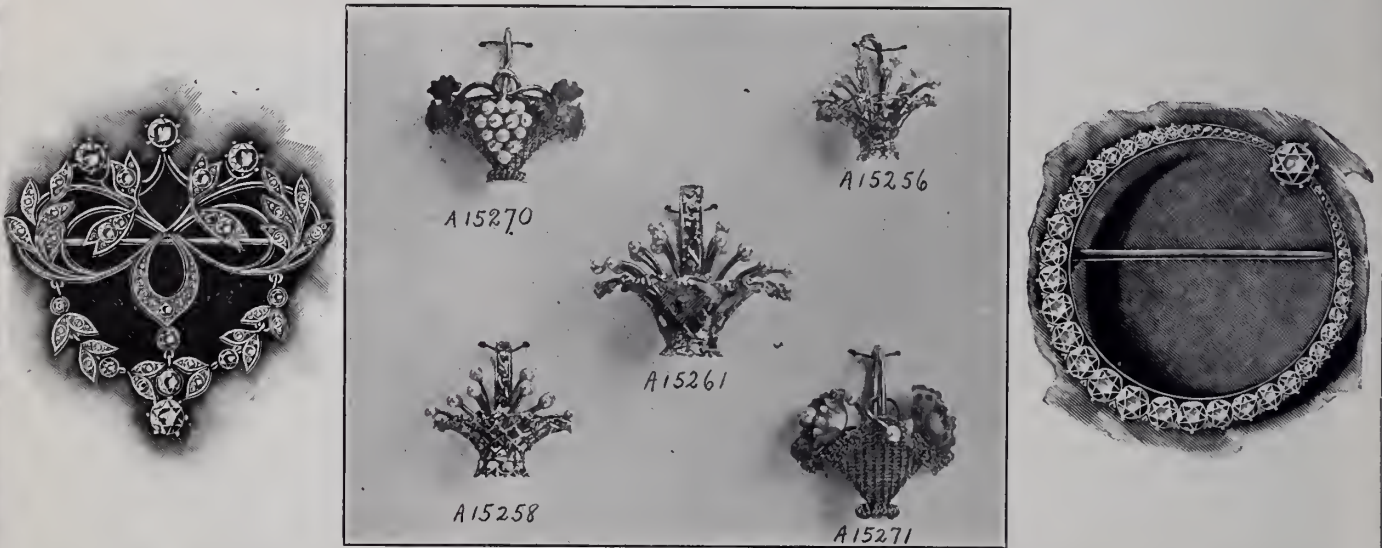

shell trumpet sits at the foot of the group, another on the edge of the upper shell.

The group on another epergne consists of the figure of a young female who has

On the same page (109) is illustrated a decorative pitcher, also in a set of two. These are to serve as table centers; both are tall and slender and stand upon oval

The sixth room, like the second, contains simple table dishes, with some complete sets for as many as 200 persons. The seventh and last holds, according to the remembrance of the visitor, only coffee and tea sets. A whole army, he says, of experts must be required to keep these immense quantities of silver plate in good condition. This is done so perfectly that it might be an object lesson to many shopkeepers. The most elaborately ornamented mediæval goblet, with its hundreds of corners for dust and grime, is here as clean as the plain silver plate of daily use. The large and heavy pieces are moved to the floor where the cleaning is done and to the workrooms



SILVER TRAY AND PEDESTAL TO HOLD DECORATIVE PITCHER.

seized a youth. A dolphin, two playing children and the large shell complete the group in a similar manner as in the epergne first described.



IMPERIAL SWORD OF THE KINGDOM OF PRUSSIA. XVI. CENTURY.

trays (as above), with two handles and a pedestal-like elevation in the center. This pedestal has four knobs, from which are suspended two drinking horns, shaped like rams' horns, not visible in the cut because the photograph was taken from above. On the pedestal and on the horns hang medallions bearing the arms of cities. Other city arms are shown on the edges of the horns. The reliefs on the body of the pitcher show humorous hunting scenes, children who have caught a hare, and others who are afraid of a porcupine. The handle is formed by the figure of Diana, holding on by the branches of a stag's antlers. Beneath, on the body of the pitcher, is a hunting trophy with a boar's head. On the front is the escutcheon with the royal initials, held by a child. On the tray, beneath the handles, are two reliefs—Diana resting upon a boar, while a hunting dog beside her has brought a woodcock; and a combat of a naked man with a bear. On the body of the other pitcher are reliefs of children with a bird's nest, and of Cupid, bound and mocked by young Satyrs. Between the branches of the antlers is the figure of Bacchus, with thyrsus wand; beneath are trophies consisting of musical instruments. On the front appears an escutcheon, as in the first mentioned. On the tray are seen two reliefs—youthful Bacchantes with a panther and drunken Satyrs.

Another cut on this page shows one of the large candelabra. The shaft of each is in the form of a slender curved vase, ornamented with shields bearing insignia on enameled ground. At the foot are trophies in form of musical instruments, with palm leaves and hymeneal torches. The crown consists of heavily curved arms, decorated with foliage, through which two fantastic dragons are coiling; two Tritons, a male and female, are seizing the dragons, and children are playing in the branches. Each crown carries 17 candles in flower-shaped sockets.



ONE OF A PAIR OF RICH CANDELABRA.

by hydraulic power, and great wooden tongs are used to lift them up onto the wide tables. This could hardly be done in any other way on account of their great weight.

The foundation of the present rich collection of table dishes was laid by the predecessor of Frederick the Great, who, although extremely economical, had a warm heart for his silver chamber. Frederick the Great was obliged to melt down a great part of the treasure to pay the expenses of his wars, as he also sacrificed the historically famous balcony in the "Rittersaal" of the palace. A number of pieces, it is true, were later, in more prosperous times, restored and the treasure increased (with the exception of the balcony above mentioned, which was imitated in wood, silver plated),

TRY US ON DIAMONDS

Lissauer & Company

52-54
Malden Lane
NEW YORK



*Are you coming
BY THIS BOAT?*

E. HOPKINS

CUTTER DEALER

58A @ 58B HATTON GARDEN
LONDON, ENG.

**EMERALDS RUBIES
SAPPHIRES PEARLS**

*Comparisons are never odious
to the buyer*

HIRSH & HYMAN,

IMPORTERS AND CUTTERS OF



2 MAIDEN LANE, NEW YORK

Broadway-Malden Lane Building

Tel. 4457 }
4458 } Cort.

JOHN M. RICHARD 2 MAIDEN LANE
Room 302, NEW YORK

American Pearls and Baroques

MATCHED PAIRS FOR EARRINGS The Largest and Finest Assortment in the Market, Mounted and Unmounted.

ARTHUR REICHMAN

BUYS AND SELLS

AMERICAN BAROQUE PEARLS

65 Nassau St.

New York

RECENTLY
PUBLISHED

READY FOR
DELIVERY

Gems and Precious Stones

THEIR

Characteristics, Localities of Production, Tests and Some Current Literature.

A new book on a new plan. Tabulated, concise, authoritative.

A handy manual for every Jeweler.

CONTENTS

CHARACTERISTICS and LOCALITIES of PRECIOUS STONES

Shows in tabulated form the Chemical Composition, Crystallography, Common Fracture, Lustre, Hardness, Color, etc.

TESTS FOR PRECIOUS STONES:

Describes testing implements, methods of testing, mineralogical characteristics, specific gravity, dichroism, tests, etc.

FAMOUS DIAMONDS OF THE WORLD.

SOME FAMOUS DIAMONDS. BIRTH STONES OF VARIOUS NATIONS.

GEMS FOR THE DAYS OF THE WEEK.

POETRY OF GEMS.

BIRTH STONES AND THEIR SIGNIFICANCE.

SIGNIFICANCE OF SOME GEMS.

BIRTHDAY FLOWERS.

ZODIACAL SIGNS OF FLOWERS.

WEDDING ANNIVERSARIES.

FLOWERS OF THE MONTH.

OFFICIAL FLOWERS OF THE UNITED STATES.

CLOTH, POSTPAID, \$1.00

PUBLISHED BY

**The Jewelers' Circular
Publishing Co.**

11 John Street New York

but there is an especial dearth of specimens from the 18th century.

Anton Springer, the famous historian of art, says that the rococo style, which flourished in the 18th century, owes its existence to the silversmith, not to porcelain work, as has been supposed. The artisan can easily fashion the foliage and shell-like forms, characteristic of rococo, from the curved surfaces of the lustrous metal; his material is, indeed, much more pliable than that of the modeler of porcelain, which, in its unburned state, forbids any graceful play of form. If more rococo silver had come down to us its importance in the history of art would be widely recognized. But the intrinsic value of the metal caused the most superb works of art to be melted down in times of need, that the silver might be used for coin.

The unfortunate passion for "modern" centerpieces, etc., has also led to the destruction of many valuable artistic creations. Porcelain was not subjected to this fate in the same degree. It was consigned to dusty lumber rooms when it became old-fashioned, but was seldom broken up. Springer's opinion, however, is opposed by some authorities. It is said that the rococo period in France was an inevitable outcome of the baroque, as this was of the Renaissance; and that neither the goldsmith or the porcelain modeler invented the forms, but that they developed naturally. This question we may leave.

In the year 1700, 52 independent gold and silversmiths, of French descent, were settled in Berlin alone; they had been brought to Prussia by King Frederick I., a prince who fairly reveled in massive gold and silver plate. But German masters also achieved important work; the world famous nautilus cup of the Green Vaults at Dresden, long attributed to Benvenuto Cellini came from the workshop of the goldsmith Bernhard Quippe, of Berlin. That Frederick I., the splendor loving monarch, gave the gold and silversmiths plenty of work, we can easily imagine; but that his son, Frederick William I., economical to the point of niggardliness, who had money to spare only for his beloved soldiers, spent almost 3,000,000 thalers in adorning the rooms of his palaces with artistic silver work, no one would believe, were it not shown by the accounts and inventories of the time.

A contemporary nobleman, the Freiherr von Pöllnitz, who had traveled extensively, declared that he had seen nowhere else in the world such an astonishing quantity of silver work as in Berlin. Especially magnificent was the so-called "Golden Cabinet," fitted up by the Queen, Sophia Dorothea. "The chandeliers and scones, the little tables, tiles of the chimneypiece, etc., all of pure gold, excited such universal wonder and admiration that both citizens and strangers who had seen London and Versailles must confess that neither of these cities could show anything to compare with this." So says another eyewitness. Of all this treasure, only a few scattered pieces are now extant. Frederick the Great, immediately after his accession, had the objects of the Golden Cabinet melted down to make a golden table service, whose value

the maker of it, Christian Lieberkühn, gave as 129,736 thalers.

In 1711, and again in the time of the Seven Years' War, Frederick had still more silver plate melted down for coin. But the greater part of the Prussian silver treasure was lost in the calamitous years from 1806 to 1813. The famous golden table service just mentioned went towards paying the first million of the war indemnity demanded by Napoleon in 1808, and the rest of the royal silver was converted into coin. At

Parliamentary Regalia of the Orange River Colony.

THE Parliamentary regalia of the Orange River Colony consists of a mace with its fittings, a black rod, badges, to be worn by the messengers of both Houses, and a set of four ballot boxes.

The mace, of solid silver richly gilt, is modeled on the historic one installed in the House of Commons during the reign of Charles II. The vase-shaped head bears,

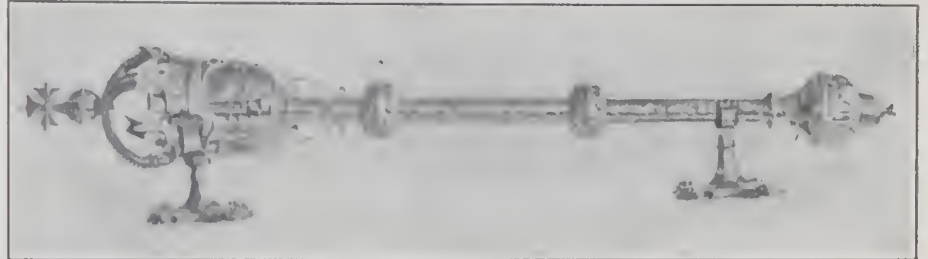

THE MACE OF THE ORANGE RIVER PARLIAMENT.

the height of the distress, all gold and silver plate not sold to coin into money was subjected to a tax of one-third of its value, and all newly made articles were taxed at one-fourth of their value. It is not surprising that under these circumstances almost all the silver was melted down; and hence it is also that good German silver from the 18th century is a very rare private possession and commands high prices.

From the silver furniture of King Fred-

in panels, the rose, thistle, harp and the arms of the Orange River Colony, with the initials E. R. The back rod, of ebony with rich mounts, the upper one of which is of 22 karat gold, is an exact replica of the black rod in the House of Lords. It carries a sovereign of the year 1906 embedded in the lower band.

The badges to be worn by the messengers are of solid silver gilt, and distinctive in character. The chief messenger of the



A PART OF THE PARLIAMENTARY REGALIA OF THE ORANGE RIVER COLONY.

erick I. of Prussia, outside of a few silver mirror frames, only two armchairs remain, which are now used as thrones. We present a picture of one of them. It is the work of Sebastian Mylius of Augsburg, and dates from the year 1700. The silver is embossed in handsome designs throughout and partly gilt.

J. H. Woodstock, Clear Lake, Ia., is confined to his home by illness.

upper house bears the royal arms suspended by an oval link chain and having as pendant a replica of the black rod surrounded by the garter. The messengers of the lower house bear the royal arms suspended by a chain and having the figure of Mercury as pendants.

Edwin A. Parks, Odin, Ill., has admitted his son into the business. The firm style will be Edwin A. Parks & Son.

To show our absolute confidence in the stability of the prices of Diamonds we will add to all bills purchased from us, from this date on, the following guarantee :

If at maturity of this bill the market prices are less than those charged for the above goods, we guarantee to refund the difference between the then existing market prices and the prices charged on this bill.

CYRUS PRICE & COMPANY
NEW YORK

JEWELRY IMPORTS AND EXPORTS

A Review of Our Commerce in Clocks, Watches, Jewelry, Gems and Kindred Lines as Shown by the Government's Statistics.

WASHINGTON, D. C., Jan. 31.—The latest statistics, covering the work of the United States during the past fiscal year, show that there has been a large and continued growth in our exports and a very material and unprecedented growth in the value of our imports. To illustrate, it is stated that the total exports, in round numbers, amounted to \$1,888,000,000, an increase of \$137,000,000 over those for 1906, and as compared with an average increase during the past 10 years of about \$83,000,000. The exports exceeded those of any earlier year in the history of our foreign commerce. The total value of the importations during the year was placed at \$1,434,000,000, or an increase of \$208,000,000 over those for 1906, and as against an average annual increase during the past 10 years of about \$67,000,000, making the total imports, like the exports, the greatest of any year in our commercial history. Yet in the face of this we are confronted with the insistent, scarcely-to-be-downed cry of hard times. Certainly it is not the condition of the commercial factors that are causing this cry.

Coming to analyze these figures we find that the value of articles required in the manufactures formed the largest percentage of both the imports and the exports. On the latter side, crude materials for use in the manufactures reached a total value of \$593,145,135, or an increase of slightly more than \$92,000,000 over those of the preceding year; while of materials partly manufactured and for use to be further manufactured, the total value exported was \$259,414,784, or an increase of \$33,000,000 over those for the fiscal year of 1905-6. Finished manufactures showed a value of \$480,708,667, or an increase of \$21,000,000 over those for the year previous.

Taking the other side, the importations, we find that those of raw materials to be used in the manufactures reached a total value of \$477,027,144, or an increase over those of the year previous of \$62,000,000; of articles partly manufactured and to be used in further manufacturing processes the total value of the importations during the year was placed at \$274,096,464, an increase of \$54,000,000; while the manufactured articles entered during the year showed an increase over those of the year previous amounting to \$56,000,000, or a total value during the past fiscal year of \$364,192,884.

This growth of trade has pretty generally extended to nearly all countries with whom we are in communication commercially, with the single exception of China, and the trade with our non-contiguous countries is also progressive.

Taking a brief glance at the export trade in clocks and watches for the past three years with our non-contiguous countries we find that in 1905 the value of these exports to the Philippines was placed at \$6,924 in 1906 there was a decrease to \$5,761, and still further during the past fiscal year to \$3,075. Turning our attention to our exports of these articles to Porto Rico we find that in 1905 the value was \$5,727; in

1906 it was \$9,291, and in 1907, \$17,311, so that it has more than trebled during the past three years. The trade to Hawaii is also increasing very satisfactorily. In 1905 the total value of our shipments of clocks and watches to that Territory was \$11,594; in 1906 this had been increased to \$14,455, and still further last year to \$19,215.

With the single exception of the years 1902 and 1903 the growth in the export trade of American made clocks and watches has been steady and increasing. In 1900 the total value of these exportations was reported at \$1,977,694; in 1901 it had increased to \$2,340,751; in 1902 it fell to \$2,144,490, and still further in 1903 to \$2,133,529; in 1904 there was an increase to \$2,281,195; 1905, \$2,316,414; 1906, \$2,598,441; and in 1907 to \$3,169,272.

Previous to the year 1900 the export trade in jewelry and other American manufactures of gold and silver had only twice reached the million-dollar mark, once in 1854, when the value reported was \$1,361,984, and again in 1892, when it was \$1,026,188; since 1900 there has been a steady increase in the exports under this heading, as will be seen by the following figures; in 1900 the value was \$1,143,638; in 1901 it had increased to \$1,229,672; in 1902 to \$1,338,347; in 1904 there was a decrease to \$1,293,021, only to increase again in 1904 to \$1,365,654; in 1905 to \$1,419,225; in 1906 to \$1,763,470, and in 1907 we find the banner year of the export trade with a value of \$2,060,144.

Of the total exportations of clocks and watches of the past fiscal year to the total value of \$3,169,272, the distribution was made as follows, that is, taking into account only the grand divisions: Europe, \$832,803; North America, \$1,129,173; South America, \$259,752; Asia, \$609,609; Oceania, \$313,570, and Africa, \$24,365.

Looking at the exports of jewelry and other American manufacturers for gold and silver, in the same way we find that out of the total exportation of \$2,060,144, Europe received, \$486,733; North America, \$1,428,120; South America, \$111,517; Asia, \$12,957; Oceania, \$18,235, and Africa, \$2,583.

In point of valuation the importations of diamonds and other precious stones stood 10th in magnitude and represented 2.95 per cent. of the total importations of all classes of goods.

Turning to the importations of manufactures of gold and silver, including jewelry, we find a rather peculiar condition of affairs; from 1901 to 1903 there was a steady decrease in the value of these importations; in 1904 there was a slight increase only still further to fall in 1905, to be followed by increases during the past two years, though a glance at the following

figures will show that the value is not yet what it was at the beginning of the present decade:

1901.....	\$3,790,671	1905.....	\$1,303,652
1902.....	2,642,345	1906.....	1,739,953
1903.....	2,007,433	1907.....	1,779,527
1904.....	2,048,821		

With the exception of 1905 there has been a steady increase in the importations of clocks and watches into the United States evidenced by the following figures:

1901.....	\$2,038,239	1905.....	\$2,966,495
1902.....	2,460,324	1906.....	3,105,136
1903.....	2,672,310	1907.....	3,593,173
1904.....	2,990,474		

The importations of ivory in its natural state, which reach a total value of \$2,472,574, as against that of \$1,995,544 for the year previous only stands 28th in magnitude.

Among the other notable articles of importation are unmanufactured shells, including mother-of-pearl, of which there was an increase in value as compared with the year previous from \$1,247,312.50 to \$1,489,613.53.

Of the articles subject to duty, which were imported during the past year, diamonds and other precious stones stand 17th in point of magnitude. The value of the importations of diamonds, not set, during the year was \$23,933,369, on which the duty collected at 10 per centum ad valorem amounted to \$2,393,336; in 1906 the total value was \$24,285,567.96, and the duty on same, \$2,428,556.80.

Of all other precious stones imported during the past year the total value was \$6,986,478.38 and the total duty of \$777,078.86, amounted to an average ad valorem duty of 11.12 per cent. In 1906 the total value of these importations was \$5,311,998.79, and the duty amounted to \$586,707.69, or 11.04 per cent.

The duty collected on the \$3,083,776.52 worth of foreign clocks and watches imported during 1906 amounted to \$1,219,802.59, or an average of 39.56 per cent. On the value of \$3,523,076.19 imported during 1907 the duty collected amounted to \$1,375,179.27, or 39.03 per cent.

The value of the importations of jewelry alone, during the year ending June 30, 1906, was placed at \$847,382.21, on which the duty collected at 60 per cent. ad valorem amounted to \$508,384.19; in 1907 the value was \$1,088,608.56, and the duty, at the same rate, amounted to \$653,099.25.

Turning to the manufactures of gold and silver, we find that in 1906 the value of these importations was placed at \$859,386.90, the duty collected to \$372,234.86, or an average of 43.31 per centum ad valorem, in 1907 the total value of these importations was placed at \$775,919.83 and the duty to \$304,049.20, or an average of 39.19 per centum ad valorem.

The subdivisions under which imports have been classified have been somewhat altered during the past year and now include the following, the returns showing the values for the past five years, as follows:

	CRUDE MATERIALS FOR USE IN MANUFACTURING.			
	1903.	1904.	1905.	1907.
Free—				
Agates, unmanufactured.....	\$451	\$1,325	\$754	\$915
Brazilian pebble, unwrought or unmanufactured.....			24,830	7,967
Coral, marine, unmanufactured.....			1,302	483
Diamonds, uncut, including miners', glaziers' and engravers', not set.....	10,933,188	8,776,418	10,390,917	11,154,152

**Reproduction of Cablegram Received by the Jewelers' Circular-Weekly
from the President of the London Diamond Syndicate.**

2 T W

COMPAGNIE FRANÇAISE DES CÂBLES TÉLÉGRAPHIQUES.

FRENCH TELEGRAPH CABLE COMPANY
 BROAD ST. (ALWAYS OPEN)
 TELEPHONE 467 & 462
 100 BROADWAY
 TELEPHONE 8500
 100 BROADWAY
 TELEPHONE 1238
 66 FIFTH AVENUE
 TELEPHONE 1004
 281 FIFTH AVENUE
 TELEPHONE 367
 MADISON SQ
 ORLEANS, MASS.



TIME. 1267
 DATE. JAN 27 1908

PARIS.
 38 AVENUE DE L'OPERA.
 LONDON.
 24 ROYAL EXCHANGE, E. C.
 2 MINING LANE.
 HAVRE.
 40 RUE DE CHILON.
 BREST.
 30-32 RUE DE CHATEAU.
 ANTWERP.
 AGENCY, 14 RUE VERUS.
 ST. PIERRE, MIQUELON.

The following MESSAGE is received via FRENCH TELEGRAPH CABLE, subject to the terms and conditions printed on the back hereof, which are ratified and agreed to.

JS 22 LONDON 23

JEWELERS CIRCULAR NY.

SYNDICATE WILL CONTINUE THEIR POLICY OF MAINTAINING
 PRICES AND THIS IS IN AGREEMENT WITH THE DEBEERS AND
 PREMIER COMPANIES

ABRAHAMS

(11 JOHN ST.)

Cable and Telegraph addresses registered at telegraph offices in any part of the World are available for the delivery of Cablegrams sent by this line. No inquiry respecting this Message can be attended to without the production of this paper. *Repetitions of doubtful words should be obtained through the Company's offices, and not by DIRECT application to the sender.*

Henry E. Oppenheimer
 Julius Raunheim

Telephone, 621 Cortland
 Cable Address, "Rockcork," New York

Henry E. Oppenheimer & Co.

Precious Stone Merchants
 Cutters and Importers

Three Maiden Lane, New York

London
 50 Holborn Viaduct

Paris
 44 Rue Lafayette

Antwerp
 90 Rue Pelican

Amsterdam
 8 Tulpsstraat

CRUDE MATERIALS FOR USE IN MANUFACTURING—(Continued.)

Diamond dust or bort.....	827,996	662,489	447,575	133,752	189,121
Other precious stones, uncut.....	46,368	89,490	278,783	126,047	156,327
Animal ivory.....	1,204,628	1,075,592	1,642,958	1,478,937	2,005,474
Vegetable ivory.....	192,093	229,944	410,883	516,607	464,931
Flint and flint stones, unground.....	106,197	97,964	133,874	215,899	278,392
Mother-of-pearl, not sawed or manu- factured.....	1,472,098	805,568	650,243	890,432	1,085,500
All other shells, unmanufactured.....	537,229	341,327	351,335	356,080	403,814

MANUFACTURES FOR FURTHER USE IN MANUFACTURING.

Free—	1903.	1904.	1905.	1906.	1907.
Glass enamel, white, for watch dials...	\$12,048	\$9,877	\$11,187	\$8,457	\$13,711
Glass plates or disks, rough cut or un- wrought, for optical instruments....	217,612	215,583	177,457	199,500	218,491
Gold and silver sweepings.....	85,781	92,396	72,985	97,661	116,976
Gold beaters' molds and skins.....	36,507	37,799	35,796	34,825	34,570
Pewter and britannia metal, old.....	4,306	440	3,773	31,262
Dutiable—					
Diamonds, cut, but not set.....	15,574,598	10,028,452	17,019,530	24,282,897	23,965,438
Other precious stones, cut, but not set, including pearls.....	4,952,069	4,069,759	5,624,701	5,258,412	7,002,984

MANUFACTURES READY FOR CONSUMPTION.

Free—	1903.	1904.	1905.	1906.	1907.
Art works.....	\$296,626	\$604,311	\$355,258	\$766,933	\$706,696
Coins, medals and other metallic arti- cles bestowed as trophies or prizes...	5,762	105,850	8,637	17,486	20,952
Dutiable—					
Agates, manufactures of.....	22,780	16,864	18,129	20,747	24,180
Alabaster, manufactures of.....	8,659	7,970	7,129	11,676	11,078
Art works.....	4,013,689	2,681,951	3,996,066	4,141,849	5,160,569
Clocks and parts of.....	489,626	621,239	486,765	539,793	610,060
Watches and parts of.....	2,182,684	2,369,235	2,479,730	2,565,343	2,993,113
Coral, manufactures of.....	25,529	8,465	11,214	19,077	25,727
China, porcelain, parian and bisque, not decorated.....	1,072,714	1,337,381	1,171,644	1,113,696	1,257,051
Do., decorated.....	9,003,852	10,193,072	10,938,072	11,401,357	11,885,680
Ivory, manufactures of.....	72,755	74,497	73,940	82,247	69,544
Jet, manufactures of.....	903	5,352	2,787	1,536	4,025
Jewelry and manufactures of gold and silver.....	2,007,433	2,048,821	1,303,652	1,739,953	1,779,527
Rock crystal, manufactures of.....	5,071	3,106
Shell and mother-of-pearl, manufac- tures of.....	116,865	139,596	127,344	121,644	140,073
Spar, manufactures of.....	345	502	430	3,417	1,396

EXPORTS.

CRUDE MATERIALS FOR USE IN MANUFACTURING.

	1903.	1904.	1905.	1906.	1907.
Shells.....	\$94,766	\$135,696	\$114,476	\$123,017	\$98,238

MANUFACTURES FOR USE IN FURTHER MANUFACTURES.

	1903.	1904.	1905.	1906.	1907.
Gold beaters' skins.....	\$1,140	\$800	\$600	\$150
Jewelers' ashes and sweepings.....	174,158	\$6,349	48,850	88,958	\$324,103
White metal.....	8	3	9

MANUFACTURES READY FOR CONSUMPTION.

	1903.	1904.	1905.	1906.	1907.
Art works, paintings and statuary....	\$512,558	\$409,694	\$410,593	\$532,446	\$297,156
Clocks and parts of.....	1,091,724	1,186,279	1,192,246	1,304,451	1,445,290
Watches and parts of.....	1,041,805	1,094,916	1,124,168	1,293,990	1,723,982
Copper coins, U. S.....	41	37	20
Nickel coins, U. S.....	2,650	11,408	1,100
Curios, antiques, etc.....	1,698	2,582	3,525	10,318	6,037
German silver.....	27,244
Table cutlery.....	69,848	107,826	90,060	63,683	74,999
Ivory, manufactures of and scraps..	68,816	60,836	54,646	29,777	51,289
Jewelry.....	939,797	964,659	1,033,808	1,072,351	1,287,111
All other manufactures of gold and silver.....	353,224	400,995	385,417	691,119	773,033
Plated ware.....	662,708	693,618	703,783	842,256	837,451

REIGNING PARIS FASHIONS.

NOVELTIES IN JEWELRY NOTED AT FRANCE'S CAPITAL.

PARIS, Jan. 22.—The long neck chains, coming more and more into fashion, are enhanced by the motives of artistic workmanship that is very much appreciated and which surpasses the value of the stone settings. With modern art, the translucent enamels have regained their former popularity. Here are little leaves of archaic design in translucent enamel, of a bluish green, separating solid links of dull gold of elongated form. Fifteen of these little leaves, all different, make a charming chain. The perfection of workmanship, the elegance of this jewel, ensures its becoming an attraction in the show case on the day when some new freak of fashion will no longer allow it to be worn.

A new fashion that is obtaining a great hold on the fashionable trade in jewelry, etc., in Paris, and which merits more extended notice, is known as "jewelry with personal portraits." By restricting the expenditure on the portraits, it can be made reasonable in cost, on the other hand, where the portraits are works of art, the jewels may be proportionately beautiful and costly. There are two classes of purveyors of this portrait jewelry in Paris, first the regular goldsmiths, jewelry and watch dealers and the other, special art dealers, to whom the work of the portrait painter is more of an object than the sale of jewelry, the latter being not only not first class, but often of quite inferior quality, whereas the portraits are executed with extraordinary care and for this reason these establishments find a larger trade than the jewelers and gold-

smiths, although there is little difference in the cost of the portraits, both being high.

As a base or background for the portraits enamel or semi-enamel is usually employed because this material lends itself best to the purpose and on it the best and clearest effects are produced. For the most part, the portraits, in the Parisian jewelry industry, are embodied in brooches and bracelets, and it is here that the Parisian ladies are patrons, whose orders run up into hundreds and thousands. In the brooches the small enamel plaques are usually applied in elongated, round or rhomboidal form, in the upper forward part and either soldered on directly or attached by means of small claws or teeth; very often, to make sure, both means of attachment are employed. The claws or other fastenings are then as a rule so set off with stylish and artistic frame work that the setting is entirely eclipsed and not to be noticed. In the bracelets (rings also are worn by ladies, with personal portraits) the portraits, or enamel plaques or shields, are applied in a variety of ways, often at the sides, or in the center and also on thin, short chains, a mode of fastening that has only come into vogue during the past business year.

Even the gentlemen in Paris, favor the "portrait fashion in jewelry" to a remarkable extent, and in their case it is in scarf-pins and watch-chain pendants, that the portraits are worked in. They are ornamental and in settings that in material and pattern, harmonize with the entire article; it is on watch-chain pendants that among the Parisian male world we most frequently see these portraits in the so-called "buloques" (charms) fastened either at the upper end, in the middle of the watch-chain, or at its lower end. Regarding the Parisian feminine world, it may be added that on the hat pins, the portrait shields are likewise worn, very small and with ornate settings. The prices for the portraits, as well as for their setting in the various ornaments, differ, as already stated, very considerably. They can be obtained (exclusive of the jewelry setting, of course), for three francs (60 cents) each, but you can also pay 100 and 300 fr. (\$20 and \$60).

A very attractive novelty in jewelry is a collection of talismans, ornamented with the stone of destiny, corresponding with any month of the year and intended to keep off evil influences. It is an elegant trinket in gold or silver, with a motto, to be suspended from the watch-chain or from a bracelet. The stone is larger or smaller according to the value of the jewel.

They are making of old-fashioned pattern very pretty necklets, for mounting on velvet, or they are mixtures of stone settings and fancy work; topazes and amethysts, pearl shell surrounded with mar-cassite and old paste stones. In these parures, which have the appearance of beautiful jewels, the stones may be of low value. Very becoming, they set off a simple toilet. Being of charming appearance they are worn with great freedom by ladies who are owners of the richest and fullest jewel cases.

CONSTANCE DE FASSELLE.

Clark & Noah, Koseiusko, Miss., have dissolved partnership, B. L. Clark continuing alone.

EICHBERG & CO.,

IMPORTERS AND CUTTERS OF

DIAMONDS,

65 NASSAU STREET, (Prescott Building.) NEW YORK.

"There is Nothing in the Art that we cannot do."

Special Attention

GIVEN TO OUT OF TOWN ORDERS

The International Gem Co., Inc.

12-16 JOHN ST., NEW YORK

TELEPHONE 1241 GORTLAND

Lapidaries and Importers of Precious Stones

SPECIALISTS IN REPAIRING AND REPOLISHING RARE AND VALUABLE GEMS
DRILLING—ENGRAVING—SLITTING

A. ROSEMAN, 9-11-13 Maiden Lane, New York

IMPORTER OF

DIAMONDS

Maker of Diamond Jewelry



TRADE-MARK.

Established 1872

HEADQUARTERS FOR

AMERICAN WATCHES

HIMALAYA MINING COMPANY

MINERS AND CUTTERS OF
PRECIOUS AND SEMI-PRECIOUS STONES

537 FIFTH AVENUE

NEW YORK

LONDON
PARIS

OBERSTEIN
PROVIDENCE

LOUIS FELDENHEIMER

Importer and Cutter of

PRECIOUS STONES AND PEARLS

41 MAIDEN LANE

NEW YORK



The Umbrella, shedding great tears of rain on the floor, said: One would hardly think to look at me I was just purchased brand new from a glass case in a store by a lady wearing jeweled rings, sparkling bright. One little gem, turned quite out of sight, told me a secret. It was, all the rest have Wells' perfect ring adjusters to hold them up right.

CHESTER H. WELLS, Jeweler, Meshoppen, Pa.



Try Wells' Perfect Ring Adjusters

1 doz. asst. sizes 10k gold filled (gold on front twice as thick as on back), \$2.00.
1 doz. asst. sizes solid 10k gold, \$3.75.
1 doz. asst. sizes, metal, 85c. Ask your jobber for them, or I will send, prepaid, at once (only on receipt of price), two samples—one small and one medium large gold filled and one metal adjuster for 50c. Address

CHESTER H. WELLS, Jeweler, Meshoppen, Pa.

SOHN and HYMAN

IMPORTERS of PRECIOUS and IMITATION STONES

Crystals Engraved and Painted from Photo. Crests and Coats of Arms Engraved.
Stone Seal Engravers and Incrusters. Lapidary Work a Specialty.

JOBGING STONES A SPECIALTY

47 and 49 Maiden Lane

NEW YORK

INEXPENSIVE JEWELRY



To meet a present and ever increasing demand for artistic creations of medium price, we have originated an entire line of inexpensive jewelry, having devoted the same care and attention to its manufacture that our well established line of highest quality has always been given.

The identical designs have been adopted; the mountings are all of 14-kt. gold, set with precious and semi-precious stones of medium and low price, that cannot fail to attract attention and readily be disposed of.

LOCKETS

SCARF PINS

BRACELETS

CUFF BUTTONS

BROOCH PINS

FESTOON NECKLACES

ART LA VALLIERES

BAROQUE SPECIALTIES

AMETHYST and MATRIX

NOVELTIES

Representative Jewelers are invited
to send for a selection

Cooper & Forman

Makers of Diamond Jewelry

Office and Factory:

3 MAIDEN LANE, NEW YORK

REPOUSSÉ WORK AND CHASING*

ILLUSTRATED AND DEMONSTRATED BY AN EXPERIENCED ARTISAN

(Continued from issue of Jan. 1.)

BEFORE continuing our resume of the art of metal work as practiced in our islands it will be well to trace briefly the history of metal work on the Continent from the beginning of the Christian Era to the Middle Ages.

We are confronted, however, in our task with some difficulty, as very little remains of the work of this long period. Many factors have contributed to this (from our point of view), deplorable end, one of the principal being the unsettled state of Europe which lasted from the collapse of the Roman Empire until the Middle Ages. From the time that the Roman Emperor Constantine transferred the seat of government to Constantinople, which became the center of what is to-day generally known as the Byzantine Empire, the Western Roman Empire steadily declined and the Goths and Vandals and many other bar-

baric tribes over-ran Europe. Of secular objects practically nothing remains, the specimens now carefully preserved in the great national museums in Europe being for the most part ecclesiastical pieces such as chalices, altar crosses, gospel covers, reliquaries, monstrances, etc., made by craftsmen-monks, which, hidden away in monasteries and churches, escaped the ravages of time and successive invasions, and, owing to their religious associations, were saved from be-

Judging from the scenes depicted, this casket was evidently a bridal gift. Round the lid there are mythological groups with Venus, Nereids, Tritons and sea-monsters, as well as a scene showing the first entrance of the bride into her husband's house, while in the center are portrait-busts of the married couple. Arranged in panels round the body of the casket are Projecta and her maids. All these scenes are worked in repoussé and the casket is gilt.

Next in importance comes a polygonal casket containing five silver vessels which probably contained cosmetics and unguents. Round the body of the casket are eight niches, in each of which is a relief of one of the Muses, worked in repoussé. A dome-shaped lid to which a chain is attached, is secured to the body of the casket with a



Silver Basin with Relief of a Saint in Repoussé. Byzantine (VI. Century, A.D.).

baric tribes over-ran Europe. The result of these wars between the various nationalities and tribes all over Central and Western Europe, and the absence of a really great civilization or powerful empire such as the Greek and Roman had been to the Ancient World, was that much gold and silver work was destroyed, being melted down for its intrinsic value and to enable fresh designs to be worked out to suit the taste of successive owners. One exception to this state of affairs must be made in the case of the Byzantine Empire (which will be referred to later) which, although it cannot be compared with the Greek or Roman, yet had an ordered existence and civilization for many centuries far superior to any pos-



Silver Casket, Roman (V. Century). On the lid is the inscription: "Secunde et Projecta vivatis in Christo."

ing melted down for the value of the metal in which they were made.

EARLY CHRISTIAN ROMAN WORK.

Of early Christian silver-work of the Western Roman Empire there are, fortunately, still some good pieces in existence. From a study of these it is evident that the early Christian style as practiced here, was mainly an adaptation of pagan and classical ornament and illustrated mythology to which was then added symbolic items connected with the new religion, in fact, symbolism was the main feature of early Christian art. The reason for this lies probably in the persecutions to which the early Christians were subjected; but when the Emperor Constantine adopted the Christian faith and made it the State religion this was done away with and realism in art was again used to a larger extent. Some of the best pieces of early Christian Roman work now in existence are the various objects forming the so-called "Esquiline Hill" treasure, found at Rome in 1793 and now in the British Museum. The chief items in this treasure appear to have been articles of toilet belonging to a lady of rank. Her name appears with that of her husband in an inscription on the lid of an oblong casket which is the largest piece in the collection, being 22 inches long and 13 inches across. This inscription is preceded by the Sacred Monogram, clearly proving that its owners were of the Christian faith.

lock. The decoration of the lid consists of four ribs running down the sides of the dome embossed with birds and arabesques, while at the top there is a relief of a seated female figure engaged in plaiting a garland, thought to be Erato. Besides these two important pieces there are a long-necked flask with embossed arabesques, a large ewer with the inscription: "Pelegrina utere felix" (Pelegrina, may good luck attend thy use of me), a large fluted dish, four circular and four rectangular dishes with inlaid monograms, two ornaments representing fore-arms holding pomegranates, probably for the arms of a chair, two sets of horse trappings with embossed allegorical subjects and four symbolical figures of Rome, Constantinople, Antioch and Alexandria, in addition to several smaller objects, such as brooches, ring, pins, etc. The whole of this treasure, the various items of which are all made in silver, was probably buried at the time of a barbaric invasion. The date has not been fixed with certainty, but it is generally assumed to be of the fifth century and thus we get some idea of the style prevailing at that period in the Western Roman Empire.

BYZANTINE WORK.

Turning now to the eastern half of the old Roman Empire, we come into contact with a new style. From the fourth century, which marks the political separation of the eastern half of the old Empire from

*All rights reserved. Copyright, 1907, in the United States by the Jewelers' Circular Publishing Co., and in Great Britain by the Watchmaker, Jeweler, Silversmith and Optician.

The SMITH PILGRIM PATTERN



The Smith "Pilgrim"

is the best selling "thread" pattern in the trade to-day. Characterized as it is by simple elegance, refinement and dignity of design, and the grateful absence of over-ornamentation, one never tires of the Pilgrim—as one does of the heavily embellished patterns.

Every discriminating buyer knows that the Smith Pilgrim will remain permanently in demand.

Made in all the fancy pieces.

Frank W. Smith Company

Manufacturers of Sterling Silverware
GARDNER, MASS.



TRADE MARK

the western, when Constantine transferred the seat of government to Constantinople it is, as already noticed, spoken of as the Byzantine Empire. Byzantine art is somewhat complex, but to describe the style briefly, it was a compromise between east and west, between the influence of the old Latin Ancient World and the Oriental influences of Persia and similar countries roundabout. When it fairly maintained this compromise Byzantine art was at its best. Its history may be roughly divided into three periods, namely, from the foundation of the Empire to the middle of the ninth century, marking its development, the second period in which it was at its best, extending from the end of the ninth century to the sack of Constantinople by the Crusaders in 1204, and the third period which marks its gradual decline until its final debacle in 1453, when the Empire was finally crushed by the Turks, never to rise again.

Comparatively little remains now of Byzantine art, and in England we have practically none, but when one summarizes, as a whole, the work which is still in existence in the various museums and treasuries of Europe, it is seen that practically all the technical processes which we employ nowadays, were known and practised then. In the British Museum the only noteworthy specimens of plate-work are a silver paten, a silver basin of about the sixth century (first period). The paten has a cross with a running border in niello, while the basin has a relief of a saint in the center worked in repoussé. In the South Kensington Museum there are two specimens of cloisonné enamel which was introduced in the first period, as in the second it had reached a high state of excellence, as is seen by several examples on the Continent, notably a reliquary now in Limbourg Cathedral, and the various enamels on the altar-front of St. Mark's, Venice. Bronze casting was also extensively employed and more has survived of this than any other type of metal work; good specimens being on view in both our national museums. Repoussé work is least represented among our museum specimens of Byzantine metal work, although book covers and reliquaries with applied repoussé are fairly numerous on the Continent, several copies of which are to be seen in the South Kensington Museum. Most of them clearly show the two influences at work, on the one hand the classical and antique, in which sculpture and a liberal use of the figure predominated, and on the other hand the Oriental, which knew little of sculpture or the figure, subordinated form to color, and whose skill was best shown in their powerful conventional and decorative art.

(To be continued.)

The stock of Taylor Bros., Houston, Tex., amounting to \$70,000 worth of goods, is being sold by Mitchell & Tillotson, the jewelry auctioneers, of 35 Maiden Lane, New York. It is one of the greatest sales ever held in Houston.

The store of Geo. F. Howe, Manchester, N. H., was damaged to the extent of \$200 by water during a recent fire, which ruined property at that place valued in all at \$13,000.

Cameos.*

A CAMEO is understood to be a gem or other carving in relief in which the figure is engraved on a layer of light color and the background is formed of a dark layer below it. Many precious stones have natural layers of white or light color and dark transparent layers alternately. Onyx and sardonyx are most frequently used for gem cameo work.

A very ordinary class of cameo is done on shells, the common conch shell being used; the shell is naturally divided into two layers, white above and dark brown below, the work is done as in the gems, by cutting through the white layer, at the same time carving it, and showing the dark brown background.

From the earliest times in its history glass has been used as a material for imitating gems, being much cheaper and much easier worked.

As a layer of opaque glass could readily be flashed on to a dark transparent glass, and as the engraving was done with greater



CAMEO OF THE EMPEROR AUGUSTUS.

facility, the material, being softer, we can well understand that in Rome, where glass making had reached a high pitch, and when luxury was prevalent, the art of glass cameo engraving was practised to a large extent.

In various museums fragments of very large vases and flat panels, assumed to be table tops, are to be seen. Some of these are in the highest style of antique art; these are in cameo, and the grounds are of various colors, mostly tints of blue.

Though I am not going to describe glass making, yet it is well to understand the construction of a common vase. The usual method for cameo is to make a bubble of opaque white glass; this is coated with transparent blue or other color, and that again with white glass. The whole is

now blown and fashioned as may be desired.

The vase being made of three layers, the outer white one is cut or etched away where the dark ground is to be, so showing the transparent blue, which is enriched by the white coating inside; the remaining white is now carved into the required forms by steel tools. Sometimes there are only two coatings, as in the Portland vase, and sometimes more, as taste or fancy may suggest.

That glass engraving was simply an imitation of gem engraving is, I think, obvious. The earliest engraved gems we know were Egyptian, and probably that wonderful country was the birthplace of that art, as it was of many others. The Egyptians were used to working the hardest stones; the engraved granite obelisk was a common element in their architecture, and it is known that the diamond-pointed drill and diamond-toothed saw were in common use. We may be fairly sure, then, that gems were cut with a diamond drill and finished with a diamond-pointed scraper. For softer stones and glass a wheel may have been used.

In the best times of Grecian art the gem cutting was superb, and the same may be said of the Roman. Not only was the design, if required, of the most minute character, for rings and seals, but, on the other hand, for plaques; this work was sometimes of immense size. Of the latter, the two most famous examples are the Great Agate in the National Library, Paris, and the Augustus Cameo in the Vienna Collection. The former measures 13 inches by 11 inches, and is cut in five-color layers; the latter is nine inches by eight inches. Both are works of the very highest artistic excellence.

A very fine specimen of the large gem cameo is to be seen in the Gem Room of the British Museum, No. 1500; it is a beautifully modeled head of the Emperor Augustus. We have seen that the glass cameo was a development of gem engraving, and it is probable that engravers would at first work on either material if required.

The Augustus cameo is illustrated herewith.

The Bastian Bros. Co., Rochester, N. Y., has been sending out during the month of January an exceptionally attractive post card, showing, in its natural colors, the garnet, the birth stone of the month, surrounded by a heart-shaped wreath of forget-me-nots. The main design on the card is a very beautiful reproduction of pond lilies, also printed in their natural colors. Near the upper right hand corner is printed the name of the month in which the cards are sent out. This is an excellent method of appealing to a high-class trade.

Sloves & Cohen, Montreal, Can., about a week ago, at the request of John Mendelssohn, Plattsburg, N. Y., made an assignment for the benefit of creditors. The liabilities are about \$10,000. The assets consist of the stock of jewelry, both raw material and manufactured goods, in the factory of the insolvents at 15 Bleury St. Among the creditors are: A. Lorsch & Co., \$3,436; Bakes & Strauss, \$2,034; H. Baron, \$1,115; J. A. Pitt, \$1,052; Conley & Straight, \$624.

*Extract from a paper on "The Portland Vase, Its History and Its Effect on Cameo Work," by Owen Gibbons, C.C., read before the Brierly Hill Literary Society.



The Gillette Safety Razor Set consists of a triple silver-plated holder and twelve double edged, thin, flexible, wafer-like blades (24 keen edges), packed in a velvet lined leather case. Price, \$5.00. Also made in Combination Sets in a variety of styles with toilet accessories retailing from \$6.50 to \$50.00 each.

Would You Have the Coming Year Bring You Increased Patronage, Profit and Prosperity?

Do you realize that nearly every hour in the day some man is converted to the easier, quicker and more economical way of shaving himself with the

Gillette Safety Razor?

Our persistent and vigorous advertising in the leading publications of this country discloses — *and will continue to disclose* — beyond all question of doubt, the superiority of the "Gillette." It advocates the advantages of self-shaving and guides the man to your store with a five dollar bill to exchange for the best shaving device in this world.

You can readily see the wisdom of having the "Gillette" ready when he calls. The Standard Gillette Set retails at \$5.00 everywhere. Combination Sets from \$6.50 to \$50.00. Keep a good supply in stock. Write to-day for valuable selling information and prices.

GILLETTE SALES CO., 904 Times Bldg., New York City

BANQUET OF THE JEWELERS' LEAGUE

Members of Fraternal Insurance Association Participate in Enjoyable Dinner After Holding Important Annual Meeting

The annual meeting of the Jewelers' League of New York, held on the evening of Tuesday, Jan. 29, at the Cafe Martin, New York, may mark a turning point in the career of this old and well known benevolent organization, and be the beginning of its development into one of the greatest insurance companies of the country. The amendments to the constitution adopted at the meeting not only permit the organization to retain all its fraternal features and its methods of insurance now in vogue, but also permit it after this month, to issue policies of insurance under the new sections known as 6, 7, 8, 9 and 10, based on the level premium plan covering amounts from \$1,000 to \$5,000, and ages from 21 to 55, which policies can have a cash surrender and loan value, thus letting the organization offer to its members the insurance and protection that it has given in the past, or the same kind offered by the regular insurance companies.

As told in the last issue of THE CIRCULAR-WEEKLY, the amendments were adopted after a general discussion, following the reading of each section by the secretary, copies of the amendments to the constitution having previously been sent to all members and having been placed in the hands of all attending the meeting. Each section was read, discussed and explained and then voted upon.

The adoption of the amendments was followed by an informal discussion on the question of changing the name of the organization to one that will give an idea of its present general scope and not leave the impression that it must draw its members from the jewelry trade alone. This discussion was precipitated by the following resolution, which was adopted after a general debate without a dissenting vote, and the subject will now be considered by the executive committee of the organization:

Resolved, That it is the sense of this meeting that the time has now arrived, when we believe it will be to the best interests of this league and all members, to make a change in the present name of this organization, to such a name as will not be specifically identified with any trade or occupation, and believing that the same will greatly assist in the growth, prosperity and strength of this organization, we therefore instruct the executive committee to decide upon a name for the league, which in their judgment will be most beneficial and to take such action as may be necessary for the adoption of such a name as they may decide upon at a special meeting of the members to be called by the chair at the earliest possible date.

President Street reappointed the nominating committee of last year consisting of Messrs. Moutoux, Fox, Freund, Breidenbach, Levy, Bowden and Jung, and appointed the examining finance committee, R. A. Breidenbach, John R. Greason, Jr., and Theodore L. Parker. Then after a vote of thanks that was given to the officers of the organization, the meeting adjourned and about 60 of the members present went downstairs to participate in an informal banquet held in the same building on the floor below.

THE BANQUET.

The dinner took place in a private room and the diners sat at two long tables running at right angles to the head table, at which sat President Street with John R. Greason and Wm. C. Kimball at his right and Leo Wormser and S. Herbert Wolf at his left. Mr. Wolf is the consulting actuary of the League, who drew up the plan on which the new insurance feature of the League is based, and had appeared at the meeting to explain some of its features and answer some of the questions asked by the members.

The guests sat down shortly after seven o'clock and an excellent menu, good wines and music made the time pass quickly, un-



GEO. W. STREET, PRESIDENT.

til coffee was served and cigars lighted. The menu was as follows:

Céleri. Olives.
Amandes Salées.
Blue Points,
Crème Racine.
Filets de Sea Bass Dugléré.
Mignons de Bœuf Balard.
Pommes fondantes.
Spaghetti à l'Italienne.
Pigeons Rôtis.
Salade.
Biscuits Glacés Martin.
Friandises.
Café.

Between the courses an orchestra at the end of the room played popular selections, which were much enjoyed.

Dinner over, President Street arose, and after greeting the members in a few well chosen remarks, which were received with hearty applause, called upon Leo Wormser to respond to the toast "The Past, Present and Future of Our League."

Mr. Wormser's address was short, and was filled with facts and figures. He told of the League's formation in 1877, of its former presidents, Thomas Slater, from 1881 to 1884; Gilbert T. Woglom, Henry

Hayes, 1885 to 1902, and how in 1893 they had elected the present incumbent, Mr. Street, whom they hoped to have continue in office for an indefinite period.

Taking up the payment of beneficiaries, Mr. Wormser called the attention to the fact that the benefit paid for the death of Charles W. Mengee, who died November, 1878, amounted to \$159.80. He showed how the death benefits for the first 10 years was \$565,962.70, for the second 10 years, \$1,388,454, and after reviewing the amounts made under the old and new systems showed the total payment of beneficiaries to date amounted to \$3,593,644.

Tracing the reserve fund from its foundation in 1885, he showed that in December of that year it amounted to \$33,000, while at the close of December, 1907, it amounted to \$283,292, which he said he believed to be the largest fund of its kind held by any fraternal organization in proportion to its membership.

In speaking of the recent change in the plan and of assessment, and its successful operation, he called attention to the fact that the new feature adopted at the meeting should enable the League to get many young men as members, urging all present to start at once to do their part that the organization might double its membership by Jan. 1, 1909. Mr. Wormser ended up by proposing a toast "Success to the League, may it live long and prosper," which was applauded and drunk by every member in the room.

Wm. T. Gough, the next speaker, created a laugh by saying that Mr. Wormser had "stolen his thunder" and had treated his subject before him, but he then proceeded to interest the diners by tracing the history of the organization from the time when eight members met in the office of H. F. Barrows to relieve distress caused by deaths in the trade, up to the present time. In a clear, logical and at times humorous way, he told what the League had done, and what it could do, and urged the adoption of a name of general character and also urged that it be conducted upon the lodge system so that it would grow to one of the great fraternal organizations of the country.

John R. Greason, one of the original members, responded to that part of his toast as to "why he became a member," though refusing to respond to the rest of it, "why he remained a member," jokingly referring this to another speaker. Mr. Greason's remarks about getting members in the organization were thoroughly appreciated, particularly as he had introduced into the League probably more applicants than any other member of the organization.

Mr. Greason was followed by Wm. C. Kimball, whose discourse contained chunks of sound common sense, which was heartily appreciated and roundly applauded. Speaking of the League as it was, and as it is, he called attention to the fact that it was formed and progressed under the rule of young men, but that 30 years had passed and these men were no longer the young men of the trade; he, therefore, urged that young blood be placed among the officers and on the committees, and that the organization do this at the earliest possible moment. His references to the older members of the trade and of the League resulted

Manning- Bowman Alcohol Gas Stove Chafing Dish

Hot Meals Without Hot Kitchens

Sufficiently powerful to prepare as complete a dinner on the dining table as on the kitchen gas range. An invaluable adjunct to the sick room, a home convenience at all times.

The possibilities of chafing-dish cookery have been doubled by the Manning-Bowman Alcohol Gas Stove. It has three times the heating power of the regular chafing dish lamp, yet regulates to a simmering flame at a touch.



No. 75 Alcohol Stove
(Patents Pending.)



No. 307/76 Outfit, 10 Pieces, Nickel Plated

Any Cooking Utensil Can be Used With This Stove.

Chafing Dishes

(With Patent "Ivory" Enameled Food Pans)

"METEOR"

Circulating Coffee Percolators

Copper and Pewter Prize
Trophies, Mugs, etc.

Tea and Coffee Pots, Hotel Ware, etc., etc.

Manning, Bowman & Co. Meriden, Conn.

NEW YORK

CHICAGO

SAN FRANCISCO

Catalogue 53J Sent On Request

in a silent toast being drunk to those who had gone before.

Theodore L. Parker responded to the toast "Our Traveling Co-Worker," and he handled the subject ably. Before taking up this subject he spoke of the benefits he and all had derived from the organization, both from the insurance whose cost was cheap, and also from the friendships made, that were strong and dear. He spoke of the interest and pride he had always taken in the organization, and paid a tribute to the high standard and ability of its officers, winding up with his peroration for a call for three cheers for the president and officers of the Jewelers' League, which were given with a will. On the subject of "The Traveling Co-Worker," he said in part:

When the history of our League shall have been written it will be found that in the brain of the commercial travelers the League was conceived and born, and very largely has it been under their management for 30 years, and has attained its great prominence and become the giant it is, reflecting honor on its parentage, as well as grateful remembrance of its large benefactions.

Gentlemen, I need not recall to your mind by naming the commercial travelers who, from the road, have graduated into firms, partnerships, or hung out their own individual shingles—the jewelry district bears their names to-day honored names, and all along the lines of commerce the traveler has been a powerful factor and a hard worker, wise in judgment, sterling in character. I have but just merely glanced at our traveler and I think the fact has been established, that he is a "worker."

From the beginning he was with us, and jointly with all of us labored for the best interest and permanency of our League, and in mutual helpfulness has his full share of the work, satisfied that in helping others he had his greatest reward.

S. Herbert Wolf, the League's consulting actuary, told the members that the step they had taken that night was one in advance, and one which he was sure the law would soon provide for all insurance organizations. That they had taken it before it was required was to their credit, and that it would no doubt place them among the greatest organizations of the kind in the country. It was right and just, and he said he had no sympathy with the fraternal spirit that was not based on equity and justice. Mr. Wolf showed his appreciation of the step by applying for membership of the new plan, being the first applicant.

Other speakers of the evening included T. E. Willson, John F. Coffin (a guest of one of the members), and R. A. Breidenbach.

Heard in the Banquet Hall.

"Steve" Kent also spoke.

M. L. Bowden looked happy.

Why wasn't "Sam" Levy called upon?

Of course, Charlie Fox was there, and of course he circulated.

John W. Sherwood looked almost as happy as he did at the 24-Karat Club.

Handsome Jack Greason made a good interlocutor, but why wouldn't he make a speech?

Mr. Goff insisted that the friends who loved him called him "Billy," and the others William T.

The Julius King Optical Co. was much in evidence, being represented by three members of the firm.

Leo Wormser's promise to put 12 members in the organization was received with great applause. "If Leo said it, they are as good as in," remarked one

of the old members, and the statement was not contradicted.

John R. Greason's remarks about getting members came from a man who had shown how it could be done.

Dave Smith probably didn't know when he played the part of host that he was going to bring in a new member.

Among the prominent guests of the members were John F. Coffin, S. H. Wolt and George W. Tremmer. Two of them signified their intention of joining the league at once.

Much of the success of the banquet was due to the individual efforts of L. Witsenhausen who, with other members of the committee in charge, came in for considerable praise.

It took a lot of time to get the photograph taken, and before the photographer was through with his preliminary work many lost the pleasant smile which was part of their pose as they crowded toward the end of the room.

Death of Norman Galt.

WASHINGTON, D. C., Jan. 28.—Norman Galt, the last surviving member of the firm of Galt & Bro., well-known jewelers and



THE LATE NORMAN GALT.

silversmiths of this city, whose establishment now at 1107 Pennsylvania Ave., N. W., has long been patronized by the exclusive social set of the Capitol, has passed away. Mr. Galt's death occurred Tuesday at his residence, 1308 13th St. He was comparatively a young man, being in his 45th year, and in addition to being one of the most prominent jewelers of Washington, was also an important man in financial, church and social circles of this city.

Mr. Galt was a native of Washington and was the son of Matthew W. Galt and grandson of James Galt, who founded this well-known jewelry business in the year 1802. James Galt at his death in 1847 was succeeded by his sons, Matthew W. and William, as M. W. Galt & Bro., from which Wm. Galt retired in 1886, and in 1892 M. W. Galt turned the business over to his sons, Walter Allen and Norman Galt, who conducted it under the style of Galt & Bro. Walter Allen Galt died in June, 1902, since which time Norman Galt had been the

only member of the family connected with the house.

Outside of the jewelry trade Mr. Galt gave considerable time to financial affairs and was a director of the Commercial National Bank, the Arlington Fire Insurance Co., the Children's Hospital, the Board of Trade and other institutions, while in church work he was equally prominent and was a vestryman of St. Thomas P. E. Church. In all lines in which he was known Mr. Galt's personality won for him a large circle of friends who appreciate his many social qualities, his public spirit and his love for his native city. He took a distinct pride in the development and beauty of Washington, and was noted as one of her foremost citizens. Mr. Galt's death, which came after an illness lasting a month, was a surprise and shock to his friends, for though he was known not to be a well man, his condition has never been considered by his friends to be serious.

The funeral services which were held today at 2.30 p. m. from St. Thomas P. E. Church were largely attended and were conducted by the Rev. C. Ernest Smith. The pallbearers consisted of directors and representatives of the various institutions with which the deceased had been prominently identified. The interment took place at Oak Hill Cemetery.

Career of the Late Jonathan A. Briggs.

His many friends in the jewelry trade of New York received with deep regret last week word that Jonathan A. Briggs, a former well-known manufacturing jeweler, had passed away at Newburg, N. Y., Dec. 20. The funeral services were held from his former home, where he resided for 20 years or more, and the remains were taken east and interred in the family plot at Dighton, Mass.

The deceased, who was 84 years old at the time of his death, was for many years widely known in New York while a member of the jewelry manufacturing firm of Hayward & Briggs and for a long time represented his concern at the New York office, which was then at the corner of Broadway and Dey St. Mr. Briggs started the partnership in 1855 with Chas. E. Hayward and remained in the firm of Hayward & Briggs until 1886, when the partnership dissolved and Mr. Briggs retired. Mr. Hayward continued the business with his son under the style of Chas. E. Hayward & Co., but after his death, in the following year, the concern became Hayward & Sweet, and later Walter E. Hayward. At the time that the deceased was connected with the business and particularly from 1865 to 1875 his concern was one of the foremost manufacturers of Attleboro, its specialty being 18 karat rolled plate jewelry.

After retiring from the firm 22 years ago, Mr. Briggs took up no business, but spent the remaining years of his life at his comfortable home overlooking the Hudson. He is survived by a widow and two sons, and also by a brother and sister.

Fred. J. Hausner, Ithaca, N. Y., has moved from 309 to 205 E. State St., where he has better facilities for his increasing business.

HANS BRASLER & CO.

DESIRE TO ANNOUNCE
 TO THE RETAIL JEWELRY TRADE
 THAT THEY WILL PLACE ON THE MARKET
 WITHIN A FEW MONTHS A COMPLETE LINE
 of HIGH GRADE 14 & 18K JEWELRY

365 MARKET ST.
NEWARK N.J.

Some of Our Business Builders

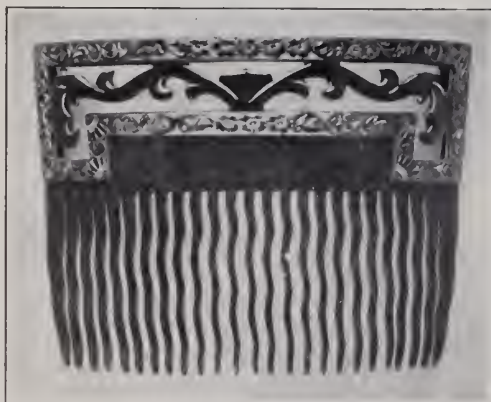

A full and complete line
 of HAIR ORNAMENTS,
 combining originality,
 price and quality.

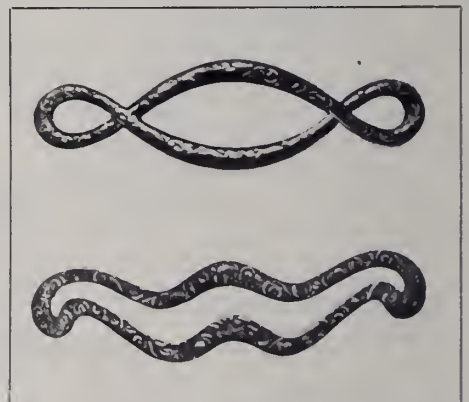

SCHULTZ & CO., Inc.

MAKERS OF BUSINESS BUILDERS

which means an up-to-date, original line of strictly 10 Karat Gold Jewelry of all kinds

FACTORY AND OFFICE:

91 Oliver St., NEWARK, N. J.



NEW YORK SALESROOM:

12-14 John St., NEW YORK CITY

THIS COMPANY WILL CHANGE ITS NAME JULY 1st, 1908, TO

Percy M. Layman **LAYMAN & STRAUS CO.** Sydney C. Straus

THE NEWS FROM LONDON

Manufacturing Trade Conditions Show no Particular Improvement—Gem Market Firm, and Outlook Fairly Good—Annual Dinner of Birmingham Jewelers' and Silversmiths' Association—New Law Proposed to Check the Illicit Trade in Bullion—Kind Words for the Birmingham Jewelry School

LONDON, Jan. 28.—January has shown nothing particularly exceptional in the way of trade. It started under the cloud of a heavy bank rate which fortunately was reduced to 6 per cent. on the 2d and to 5 per cent. on the 16th, thus giving greater possibilities to trade. In London things are still at a standstill. Short time is the rule in the factories. In some instances the workshops did not open from Dec. 24 until Jan. 8, and then only to work a short time. The wholesalers were in many instances too busy with stock-taking to entertain overtures on the part of the manufacturers' representatives.

The same may be said of Birmingham, where trade has been very quiet since Christmas. This is to some considerable extent due to the uncertain state of affairs in Lancashire, owing to the possibility of a serious dispute in the cotton industry, which would occasion a very serious loss to the Birmingham jewelry trade, as Lancashire is a very important customer. There is another reason for the slackness, and that is the unsettled condition of affairs so far as the "minimum gauge" is concerned, as manufacturers are rather wary as to what they shall produce. But despite adverse conditions a spirit of hope prevails and a belief that this year will ultimately turn out a good one for the Birmingham industries.

In Sheffield at the beginning of the year both the silver and cutlery trades were quite idle. An altogether unsatisfactory tone has prevailed during the early part of the year. The admiralty tenders for silver and silver plate ware for battleship outfits are out and Sheffield hopes to get a considerable proportion, if not the whole, of the orders.

Cutlery to the value of £21,469 11s. 5d. was exported during the last quarter, exclusive of cutlery which comes under the heading of "butchers." Pearl goods were exported to the value of £2,087 16s. 1d., horn and manufacturers thereof to the value of £7,427 9s. 11d.; platinum sponge, £6,687 1s. 0d.; electro-plate and silver, £679 13s. 9d.

A remarkable fact with regard to the trade of Great Britain for 1907 will be seen in the following figures. As compared with the total value of exports for 1906, the year just closed shows an increase of £57,498,919. These figures are certainly very satisfactory, when viewed from the national standpoint.

* * *

Despite the general depression and the unsettled state of affairs the London gem market experienced a fairly good Christmas trade. There can be little doubt that the absurd journalistic chatter which appears periodically respecting the gem markets generally and the production of artificial gems—which, by the way, THE JEWELERS' CIRCULAR—WEEKLY has done so much to combat by its reasonable, scientific criticism

—has caused a certain amount of harm in London and Great Britain generally. We are fighting it down and showing the public the absurdity of the statements. Owing to the low condition to which the stocks of the manufacturers have sunk, they are bound to make fairly big purchases, in the near future, of diamonds and precious gems. There can be no doubt, whatever—and I speak after very carefully going round the trade, and consequently with a considerable amount of authority—that prices are not at all likely to go down.

The passing of the dividend on the De Beers shares and the cancellation of the declared dividend on the ordinary Premier shares cannot be taken as an intimation that the diamond trade is in a bad way. On the contrary, it simply shows the smart business ability which characterizes those responsible. When trade once again takes its natural course we shall find both the De Beers and the Premier companies paying the same large dividends as formerly. Every man knows that it is unwise to flood the market, and moreover it is unwise when money is essential to a business to let it go out.

I gathered the information yesterday that both Amsterdam and Antwerp have taken to buying rough diamonds again, so there is a possibility of things soon becoming quite regular. As soon as America again becomes a purchaser the market will certainly reach a normal condition. There is a very good demand for the smaller classes of goods, while roses are again finding favor. Pearls of the smaller and medium sizes, and various colored stones, are in a very good demand.

* * *

One of the greatest events of the year in the jewelry and allied trades is the annual dinner of the Birmingham Jewelers and Silversmiths' Association, where for a number of years, the Right Hon. Joseph Chamberlain was the principal guest. At the 20th annual dinner, held on the 18th inst., his son, the Right Hon. Austen Chamberlain, M. P., took his place and made a speech. Pointing to the lack of employment and business, Mr. Chamberlain said that tariff reform—or, in other words, protection—was the only means for getting out of the present difficulties.

Professor Muirhead, who proposed "Success to the Association," dealt particularly with the question of technical education in the jewelry school and very ably and smartly replied to those who objected to the teaching of nature in the school. It was objected that peacocks and rabbits have nothing much to do with the jewelry trade. The professor said that the nearer the student gets to nature and the more he studies it the better it is for the student and for the trade. The school was established to arrest a decay in craftsmanship, so far as gold and silver production were concerned, and no one could deny but that

a certain measure of success had attended its efforts. No art school or technical school could possibly hope for permanent success unless it was founded on a careful observation and love of natural form and color and particularly natural movement. The speaker would say to the captious critics that the Birmingham Jewelers' School is now being conducted in a manner which must commend itself.

Frank Haseler, the chairman, who presided at the distribution of prizes to the successful students at the school, gave a few interesting particulars with regard to the success of the institution. He said that in the national competition 48 awards had been gained by students of the Birmingham school. These included a gold, two silver and three bronze medals. Mr. Haseler also replied to the critical remarks of some manufacturers who do not altogether approve the methods of teaching, and had informed him that they would rather see students making goods that are readily salable. That, the chairman said, is not the immediate object of the school. The object is to broaden the students' minds and inspire their imaginations. He appealed strongly to manufacturers not to be impatient, but to look at the work done there in a broad-minded manner, for it was an honest endeavor to train young work-people, many of whom were destined to become in the future masters in the trade.

Other features of the work of the association, referred to by the chairman, were those relating to insurance and the vigilance department. With reference to the former, he said that there was an increase of 85 firms insuring during 1907. With reference to the latter department, he pointed out that it was time the trade acted in unison and quickly to bring pressure to bear upon the authorities in order that the illicit trade in bullion may be ended. He urged upon the trade to throw aside its apathy and to get the existing acts amended or to get a new act passed, so as to deal with those who receive gold or silver stolen from the workshops.

Other events included, on the 25th, the annual banquet at the Watch and Clock Makers' Asylum. To-morrow will take place the annual banquet of the Court and Livery of the Worshipful Company of Spectacle Makers, who will entertain the Lord Mayor of London and the sheriffs. On the same night the annual banquet of the London Wholesale Jewelers and Allied Trades' Association will be held. Feb. 6 the Silver Trade Pension Society will hold its annual banquet.

* * *

I have previously referred to the enormous size of the hatpins worn by ladies. The latest fashion is in the form of a daintily jeweled dagger. These are from six to 10 inches in length and would form a really formidable weapon of defense. The hilts are frequently enameled and sometimes jeweled, and the daggers are worn not only as a hatpin, which, by the way, must make it very good for milliners because of the damage done to the hat, but also as hair ornaments for evening wear. I have seen some remarkably delicate specimens of this new form of hatpin and hair ornament.

ST. GEORGE.

WE ARE THE ORIGINATORS
OF THE
Sandwich Plates

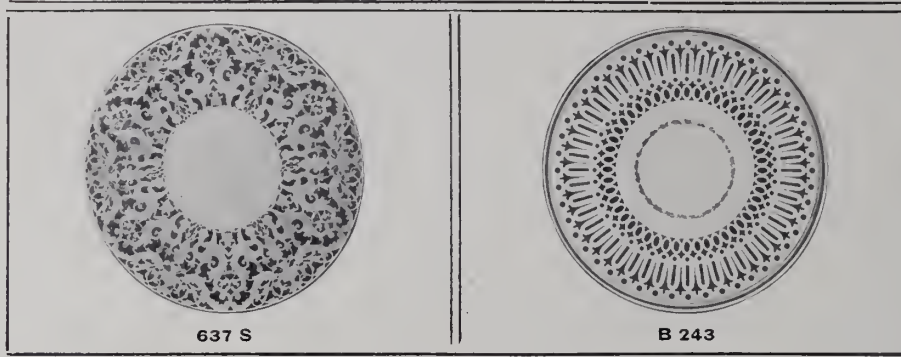

☞ A useful, serviceable piece of silverware that sells on sight. No Jeweler should be without a selection in stock. Twenty-five different styles, ranging in price from \$9.00 to \$45.00.

PHOTOS AND PRICES ON APPLICATION TO THE

ROGER WILLIAMS SILVER CO. 101 SABIN STREET
PROVIDENCE, R. I.

Ye Mount Vernon Pattern

HOLDS PRESTIGE AMONG YE
BEST DESIGNS OF

Sterling Silver Tableware

MADE IN AMERICA



It appeals especially
to ye maids and matrons
of refined taste, through com-
bining those most excellent Colonial
attributes

Strength, Beauty and Simplicity

the last being ye keynote of perfection for
ye dainty table accessories made in ye Old Bay
State in ye Silver Shop at **Greenfield** by

Rogers, Lunt & Bowlen Company

Jewelers Board of Trade Holds Annual Meeting

Members Hear Encouraging Reports of the Organization's Work and Elect Directors and Officers for the Ensuing Year

The annual meeting of the Jewelers Board of Trade, which was held last Thursday afternoon at the offices of the Board, 170 Broadway, New York, was attended by a large number of members. Efficient and satisfactory services on the part of the various departments of the Board were reflected in the several reports.

The president's address embodied a terse review of the work done by the Board during the past year and asked for the co-operation of the members for the coming year. The advantages of such an organization were clearly pointed out and an expression of the appreciation of the officers and members of the Board at the business-like methods and dispatch with which claims had been handled made up a part of the report.

The chairman of the board of directors, in presenting the name of Leo Wormser for re-election as president of the Board for the ensuing year, spoke of the acceptable way in which the affairs of the Board had been conducted in the past year and commented favorably on the reports submitted by the officers. A set of resolutions were presented asking for the appointment of a good and welfare committee.

The secretary's report called attention to the action taken in the case of dishonest bankrupts and pointed out the just punishment meted out to men trying to evade justice.

The officers re-elected by the organization are: President, Leo Wormser; first vice-president, George W. Street; second vice-president, William T. Gough; treasurer, C. G. Alford; secretary, D. L. Safford. A new director, W. H. Kinna, of the Elgin National Watch Co., was elected. The other directors were re-elected.

President Leo Wormser called the meeting to order and on motion the reading of the secretary's minutes of the last annual meeting was omitted. President Wormser then read his annual address, to which the closest attention was given. The repeated applause which it evoked testified to the pleasure it gave the members of the Board. He said:

PRESIDENT WORMSER'S REPORT.

To the Members of the Jewelers' Board of Trade:

When you elected me president of your organization, a year ago, we had 515 members. It now gives me pleasure to inform you that this year we start with a membership of 559, a gain of 44. With your co-operation our membership can be increased to 600 by January, 1909.

The Jewelers Board of Trade is in a prosperous condition. It is stronger and better equipped than ever before. Last year our income was \$77,242.25, and our expenses were \$76,288.98. In 1907 we have added \$953.27 to our surplus. The total amount of surplus, Jan. 1, 1908, is \$20,665.38, which does not include our special fund of \$10,230.76. We must not overlook our valuable assets, reports which are worth, in my opinion, a great deal more than our surplus. Our members should realize that we are one big firm.

We have had two traveling reporters on the road the past year, which cost us \$4,138.12, including expenses.

It is not our aim to increase our surplus by not giving you good and prompt service. If it must be we had better spend a part of our surplus, or all, if it is necessary.

In 1907 we have made more changes in our reference book than in 1906. This book contains about 26,000 names. The changes include street addresses, change of firm names and ratings. If our members would inform our secretary when any firm has discontinued in business, or moved, or any new firm started in business, it would help this department. In your own business you report any changes to your bookkeeper, so please remember that we members are all partners.

Our collection department, which is managed by Mr. Gray and his three assistants, is an important part of our work and will increase.

Some of our members do not understand our draft, or letter of demand, system. There is no charge made by the Board when accounts are collected in this way. During the past year we have collected over \$103,000, and in addition, over \$117,000 in drafts and claims were settled direct without cost to members. If any member desires any information on this subject our secretary or Mr. Gray will be pleased to see you at our rooms at any time. Our firm has used this draft system of collecting for many years, with satisfactory results and has more than saved our yearly dues on account of the Board making no charges for claims collected by this system.

Our Chicago office, managed by Mr. Digges, is



LEO WORMSER, PRESIDENT.

showing good results, and with the help of our Chicago directors our membership has increased and will continue to do so.

Mr. Murray, the manager of our Providence office, is well known and furnishes us with information of great value. Our Providence directors have looked after our interests and have held monthly meetings which renders great assistance in making that office a success.

Last February your board of directors talked of the advisability of opening a San Francisco office. After investigating this matter for several months the question was indefinitely postponed, but not until we had the vote of our members on the question, which resulted as follows: Number of members entitled to vote, 499; 206 members voted to open this branch; 130 members voted "No," without comment; 40 members reported "No business on the coast;" 21 members voted "No," for various reasons, making a total of 191 who voted "No;" 21 reported "Indifferent;" 81 members did not vote.

I feel confident in time that our board will find it necessary to open a branch in San Francisco.

The system of obtaining foreign reports was taken up by your directors, but no action was taken by the committee as they did not consider it advisable to do anything at that time, but if this could be accomplished it would help our board.

The board has saved its members a large amount

of money by taking charge of extensions and compromises, and had all our members co-operated with us we would have shown greater results. If our members will send their claims through the board when a failure occurs it will help them and enable us to investigate the failures, and if any fraud is discovered our finance committee can act immediately and thereby obtain good results. If you send us your claim we can control affairs and have an approved trustee appointed and good results will be sure to follow. Please take my advice and send us all your claims. The banks have only one clearing house, so all members should have one institution to look after collections. Do this and a year from now we will be a complete success.

As the buildings which are being put up around us will make our present offices unfit to do our business in, we have made a lease for space in the new Silversmiths' Building, which we expect to occupy by May 1. This will assure us of light offices which will enable us to do our work satisfactorily.

I wish to thank the directors for their prompt attendance at all meetings, for their counsel and support. The finance committee has performed its duties with ability and willingness. The past month they have had several meetings every week. The auditing, arbitration and membership committees, our treasurer and secretary, have my sincere thanks for their faithful work.

In our secretary's report you will find much to think about. In his position he comes closely in contact with details and sees the weakness as well as the strength of our organization, and I know his first thought is always for the good of the organization and the members. I hope that you will bear this in mind as you listen to his report and consider well the statements he will make.

Mr. Alford then read the treasurer's report, which was followed by the report of the secretary, De Loid Safford. This report was a comprehensive review of the affairs of the Board, of the work done during the past year. The report was received with hearty applause and won the approbation of the officers of the society and its members. The report was as follows:

SECRETARY SAFFORD'S REPORT.

To the Members of the Jewelers Board of Trade:

In presenting this my 12th annual report, I must necessarily go over much of the same ground as in previous reports, but the details should be interesting as showing the progress made during the past year.

Our present membership is 559, an increase of 44 for the year. Our income for the year was \$77,242.25, an increase over last year of \$6,027.95, and our expenses, \$76,288.98, an increase over last year of \$6,937.88, leaving a surplus of income for the year of \$953.27, and a total surplus above all liabilities of \$20,665.38. In making this statement we only take into account as assets our cash in bank, accounts due us and our office fixtures, after charging off 10 per cent. of cost each year.

The balance in our special fund for the investigation and prosecution of dishonest failures, is now \$10,230.76. During the year we received in this fund, \$2,835.38, and expended in various cases, \$2,565.19.

REPORTS AND REFERENCE BOOK.

Our reports and reference book have been much improved during the past year by the employment of two traveling reporters, at an expense of over \$4,000, who have visited nearly all the cities of over 10,000 population, thus revising our reports by personal investigation. We trust that we shall be able to continue the system.

Our reference book has increased 11 pages during the year; 550 new towns have been added; the new State of Oklahoma, which includes Indian Territory, now extinct, is properly shown, after a thorough revision. The new and revised reports written during the year number 25,079, and we have issued to members, in answer to inquiries, 55,160 reports. The changes made in ratings, addresses, removals, deaths, failures, dissolutions, etc., number 22,863.

At times members have criticized our reference book as "full of names of people who have been dead or out of business for years," and in similar manner. If one should stop and think he would realize that it would be wonderful if there were no such names in a list of about 26,000 scattered all over this broad country. As a matter of fact, The Jewelers' Circular Publishing Co., in October last, circularized every name in our book and had returned by the postal authorities 67 envelopes, 16

of which were taken out of our book since issue, thus leaving 51 for investigation.

Again, in September last, George E. Darling, of Providence, R. I., sent out 8,000 catalogues addressed from our book, and only 13 were returned, of which three were misdirected and eight of the remainder we had already taken off our book. We think this an unparalleled record.

Our collection department handled 8,906 claims during the year and collected over \$300,000, of which amount \$103,554 was by drafts, without expense. In addition, \$117,656 in drafts and claims was also settled direct with members after notice, also without expense.

There are three good reasons why you should send all your collections to the board:

First. It benefits our reporting department, and thus the inquiring member.

Second. It keeps our attorneys in touch with us to occasionally receive a claim instead of nothing but inquiries, while the other fellow gets the fees.

Third. It costs you no more (sometimes less), and the board gets part of the fees which go into our general fund toward meeting our expenses, and naturally the greater our income the better service we can render.

In cases of assignments, receiverships, bankruptcies and deaths, where claims must be proven and filed and allowed in order to receive their pro rata, it is safe to say that creditors are losing annually over \$100,000 because they do not combine and make use of the law provided for them.

The great "bugbear" seems to be the small attorney's fee charged on the amount collected, overlooking the fact that where the dividend has been doubled the fee is insignificant.

As a case in point I cite an occurrence of recent date. The party died and a few only of our members sent us their claims, others sent them to the administrator and a few to the attorneys acting for the estate. The estate should and could have paid in full. With our few claims we could not control or prevent the manipulation of the estate. The creditors whom we did not represent got 25 per cent. and we got 50 per cent. How much did those creditors profit by saving attorneys' fees?

The bankruptcy law is here to stay—primarily the law is purposely framed so that creditors shall say what shall be done and how it shall be done. A composition is decided by the majority of creditors whose claims are filed and allowed and *who vote* either in person or by an attorney. The trustee is elected in the same way.

The whole scheme of the law is to administer it in accordance with the wishes of the creditors, hence you abandon your right and privilege when you do not appear either in person or by an attorney at the proper meetings, as you cannot otherwise *vote*.

When claims are scattered it is as impossible to get 10 or a dozen lawyers, each with one or two claims, to work together (or for that matter to do anything, as the fees don't amount to enough), as it seems to be to get creditors together where by combined effort they can control. The other attorneys, with one or two claims each, on which they will receive a fee of \$2 to \$5 each, you cannot expect to do much in the way of investigating or prosecuting, and our attorney is without the legal and moral support these claims would give him. And yet because you do not get results you condemn the law, the lawyer, the Board of Trade, and everyone but yourself.

As a case in point I quote from our attorney under date of Jan. 11, 1908:

"I acknowledge receipt of claims and power of attorney in two of them. Did not get these claims, in time to vote them for trustee—as a result the debtor's faction elected their own trustee. I imagine he will work harder for the debtor's interest than that of creditors. If I had had the claims you sent me to-day at the time of the election I could have controlled the election."

This means that if members who did place their claims with us, had done so promptly, we should even then have been able to control the administration of the estate instead of its being controlled by the debtor's friends in his interest. Even had two of the members who filed their claims with the referee, to save attorneys' fee, and thus had no *vote*, placed their claims with the Board we should have controlled the election.

Heretofore in my annual report I have taken considerable space to tell you of the good results we had obtained where you had co-operated and placed the board in control.

While we have done as well in all such cases during the past year, I propose to tell you of the cases wherein we have not done so well, because of the failure of the members (creditors) to place

their claims with us so that we were left without control, my contention being that the creditors who thus failed in their obligations to the board were the direct cause of the loss to themselves and the other members.

To illustrate I will quote our attorneys' statement in a bankruptcy case. They say:

"You will remember the referee in this case, against our objections, appointed three trustees, two of whom selected other attorneys and have inaugurated, since the first meeting of creditors, an adverse control of this estate. A majority of the trustees and their attorneys have instituted a good deal of litigation with different parties, some of whom are creditors of the estate and others, it is claimed, were indebted to the debtor, or in some way connected with him at the time of his failure. Over 40 protests to the allowance of claims have been filed, and in each case there will be litigation in establishing same.

"We regret the turn taken in this case, but at the first meeting of creditors we were not able to control a majority in number and amount so as to elect a satisfactory trustee, consequently the adverse combination succeeded in getting a referee appointment, and of course appointees favoring litigation, delays, large costs, fees, etc. We fear that the disposition to litigate extensively is prompted by a desire to earn fees out of the estate, and that nothing beneficial to the creditors will result."

And still another says:

"About Aug. 14 a petition in bankruptcy was filed by certain creditors and on Sept. 4 an adjudication took place. A stockholder and director of the debtor corporation was elected trustee. This was accomplished through their attorneys, other stockholders and directors writing the various creditors and securing their claims and power of attorney. Why creditors should have given an insolvent the control of its own assets is hard to understand."

Again, why members should send their claims to an unknown firm of lawyers, who were furnished a list of creditors by the bankrupt's attorneys, as stool pigeons, for the purpose of controlling the estate, in the debtor's interest, instead of placing their claims with the Board, is almost inconceivable, and yet this was recently done.

In one recent case members of the Board acting independently and others in direct opposition to the Board have not only accomplished nothing, but the assets which were in sight have either disappeared or the proceeds have been wasted and the debtor will go clear without his creditors receiving one cent of dividend.

Don't place your claim with an attorney whom you do not know. Don't think an attorney will do you much good acting on your claim alone as he has only *one vote*.

Even if your claim is a large one it is only *one claim* and *one vote*, and it is the attorney who acts for the trustee who must do the work.

Don't file claims with the referee and lose your vote.

Your claim may be as a bird shot, a single one will not do much harm, but all claims together would make a charge to be effective.

The objects for which your corporation is formed are stated in the constitution.

Our by-laws (Article 7) provide the plan for co-operation. What we lack to-day is that co-operation, and until you, each and all, realize this and act, we shall all suffer needlessly.

It should not be a question of friendship for the debtor or creditor or an attorney, or the like or dislike of any one, but one of business and the benefit of all.

Have confidence in the directors you elect and the committees you appoint, that they will see that the matters entrusted to the Board are fairly and wisely handled.

I sometimes feel that members get impatient because they expect too much and do not take into consideration the "law's delay," etc.

It took years to convict Hummel and actually put him in prison.

Grannis gets a certificate of reasonable doubt, after confessing.

In the case of the Kleins, after absolute proof as to their statements, the jury disagreed, and we have been waiting for a year to get the district attorney to try the case again.

It took over two years to get through with the appeals in the Betz case and finally land him in prison.

We have been busy in the Jacobs case for over four years and he is yet out on bail pending an appeal from his sentence to imprisonment for two years, even though the judge in passing sentence

stated in his opinion it was a very flagrant case and deliberately planned.

These delays are not responsible for and cannot help, and members should take them into consideration before criticising the Board.

What I have said to you is from my knowledge of the administration, or if you will, the maladministration of the law through daily contact with these matters.

I do not say these things because the Board is not a success, but because through your want of co-operation you have failed to make it the success it should be.

If by scattering your claims there is no control by a majority you each and all suffer.

We have learned by experience that unless members respect their obligations to the Board and their fellow-members, the Board will fail of complete success, as it cannot successfully fight against the apathy or direct opposition of its members at the same time that it is fighting dishonest debtors, their attorneys and those interested in defeating the ends sought by the Board.

The real question as to the Board is whether you have by and in your organization provided the proper means for looking after your interests and those of your fellow-members. It is not each man for himself but organized effort that accomplishes anything.

Don't condemn the Board when you have failed to perform your duty; the duty you, as a member, owe to the Board, to your fellow-members and to yourself.

Mr. Safford then read the corporation's report—a document which must be filed in accordance with the provisions of the law.

The meeting then proceeded to the election of the board of directors and on motion of Mr. Kaiser the old board was re-elected, with the addition of the name of W. H. Kinna, of the Elgin National Watch Co., in New York, and the substitution of C. L. Watson, of the Watson & Newell Co., for J. S. Carpenter, of the Horton, Angell Co., among the New England directors. One ballot was cast by the secretary for the following:

New York—C. G. Alford, of C. G. Alford & Co.; H. A. Bliss, of Gorham Co.; M. L. Bowden, of J. B. Bowden & Co.; O. G. Fessenden, of H. W. Wheeler & Co.; W. T. Gough, of Carter, Howe & Co.; C. R. Jung, of Jung & Klitz; F. H. Larter, of Larter & Sons; S. H. Levy, of L. & M. Kahn & Co.; Ludwig Nissen, of Ludwig Nissen & Co.; Adolphe Schwob, of Adolphe Schwob; A. K. Sloan, of Sloan & Co.; Leopold Stern, of Stern Bros. & Co.; G. W. Street, of Geo. O. Street & Sons; S. E. Thomas, of the Seth Thomas Clock Co.; Leo. Wormser, of the Julius King Optical Co.; W. H. Kinna, of the Elgin National Watch Co.

Chicago—Benj. Allen, of Benj. Allen & Co.; C. J. Dodshun, of the Waterbury Clock Co.; J. H. Hardin, of F. A. Hardin & Co.; W. F. Juergens, of the Juergens & Andersen Co.; M. A. Mead, of M. A. Mead & Co.; A. L. Sercomb, of the International Silver Co.

Providence—G. H. Cahoon, of Geo. H. Cahoon & Co.; W. A. Copeland, of the Martin, Copeland Co.; Harry Cutler, of the Cutler Jewelry Co.; T. W. Foster, of T. W. Foster & Bro. Co.; G. K. Webster, of the Webster Co.; C. L. Watson, of the Watson & Newell Co.

The election of the president being next in order Mr. Street, on invitation of the president, took the chair. Leopold Stern then named Mr. Wormser for re-election, saying in part: "I think that after having listened to the very interesting reports of the president, the treasurer and the secretary we have cause for mutual felicitation. We have cause for mutual congratulations

not alone upon the achievements of this society, but also upon the fact that the financial flurry appears to have disappeared." He then said that the present disturbance in the banking world would amount to little, as he understood that the banks were able to pay creditors in full. Mr. Stern continued:

"From my observations of our president's methods I can say that he has been loyal to his trust; he has been untiring and indefatigable in his efforts to bring about the best results for this organization and for its members. It is, therefore, my pleasure to again present for the consideration of this meeting as president for the ensuing year of this Board of Trade the name of the incumbent, Leo Wormser.

The nomination was greeted with applause and seconded by Mr. Fessenden, who paid a tribute to Mr. Wormser's administration. On motion the secretary cast one favorable ballot for Mr. Wormser, who was led to the chair and he said:

"Gentlemen, I don't think it proper at this time to say much. I am too full (laughter), but I want you to know I appreciate the honor and I hope all my expectations for the coming year will be realized. There is only one thing I want to suggest, only one; that is, that when you have anything of importance, don't trust it to a telephone or to your office boy. Call at the office, talk it over with our people, get the information you desire and, I am sure, you will be repaid for the time it takes to give us a call."

On the nomination of Mr. Kaiser, George W. Street was unanimously re-elected first vice-president. For second vice-president the name of William J. Gough was presented by Mr. Larter for re-election and on motion of Mr. Fessenden the secretary was instructed to cast one ballot for Mr. Gough.

The selection of a nominating committee came next, and it was moved by Mr. Fessenden that the same committee be re-elected. David Kaiser arose and said: "I have served to the best of my ability on the nominating committee and I believe it is time that the gentlemen present get some one else," and he then pointed out his reasons. E. R. Crippen asked to withdraw from the nominating committee and suggested the name of E. S. Smith. Mr. Kaiser named D. Rothschild, who asked to withdraw in favor of Stephen Kent. Ira Barrows, as chairman of the nominating committee, withdrew and Matthias Stratton was named. The nominating committee, as elected, is as follows: F. C. Aiken, D. C. Townsend, St. John Wood, Robert W. Adams, E. S. Smith, Stephen Kent and Mathias Stratton.

Just before the meeting closed Meyer D. Rothschild arose and, addressing the meeting, said:

"It seems to me and to some other members with whom I had the privilege of discussing the matter, that while the Board of Trade is doing splendid work and the different committees are doing all the work they possibly can do, there are other fields suggested by our constitution, called for by necessities of the general situation, which are not properly covered.

The old Goldsmiths' and Silversmiths' Guilds had a great deal of power. The Board of Trade to-day represents, I think,

19 States, has a great deal of power, but has not used all its great influence up to the present time. It stands for the jewelry trade of the United States. It stands for some 20,000 retailers. They look to the Board of Trade, or have the right to, for support, and for assistance in helping mould public opinion, in keeping misstatements out of the newspapers, and in assisting the general good and welfare of the trade.

"I believe there should be a standing committee ready to take up any question relative to the good and welfare of the members of the trade generally; a committee ready to respond to any requests for information from reputable newspapers, such questions, if you please, as a uniform memorandum or contract; any question which would be difficult and cumbersome for the trade as a whole."

Mr. Rothschild then presented a set of resolutions which read as follows:

Whereas, The constitution of the Jewelers Board of Trade provides among other objects: The reform of abuses relative to trade; the security and freedom from unjust and unlawful exactions; the diffusing of reliable information among its members: the procuring of uniformity and certainty in the customs and usages of the trade; and the promotion of a more enlarged and friendly intercourse among its members; and,

Whereas, The present standing committees of the Jewelers Board of Trade are limited to other important objects and duties, be it

Resolved, That a committee be formed called the "Committee on Good and Welfare," to be added to the standing committees of the Jewelers Board of Trade, said committee to be composed of members of the Jewelers Board of Trade, but not necessarily directors of the Jewelers Board of Trade. Be it further

Resolved, That a special committee of five be appointed by the Chair, which committee shall formulate a general plan, and outline the scope, power and limitations of said committee on good and welfare, and upon the completion of this work, the special committee shall notify the president of the Jewelers Board of Trade, who shall thereafter call a special meeting of the Board of Trade to discuss the report of the special committee, and to determine the entire question of the formation of the Committee on Good and Welfare, its scope, power and limitations. Be it further

Resolved, That the special committee of five are instructed to report not later than April 15, and that they prepare proper amendments of the by-laws to carry out their recommendations for any amendments thereof, which may be adopted at the special meeting.

Several members of the board commented very favorably on the resolutions. A committee of five, with the president as an ex-officio member, was appointed to consider the resolutions.

Directly after the meeting adjourned the Board of Directors held a special meeting, at which C. G. Alford was re-elected treasurer, and D. L. Safford, who has served the board for the past 11 years, was re-elected secretary.

The attorneys of the board, Hastings & Gleason, were reappointed.

John Hall and John Powers were taken into custody, Jan. 26, accused of attempting to break into the jewelry store of John Gruner, 11 State St., Auburn, N. Y.

Miss Helen Mossbacker, who has been engaged in the jewelry business in Wichita, Kans., has been married and has moved to San Antonio, Tex., where she and her husband will conduct a jewelry store. The store in Wichita was sold recently to J. C. Hadler.

Jewelry, Clocks, Watches, Silverware and Kindred Lines Exported from New York.

WASHINGTON, D. C., Jan. 29.—The following were the exports of jewelry, silverware, optical goods, clocks, watches and kindred lines from the Port of New York for the week just ended:

Auckland: 240 cases clocks, \$5,879; 10 cases plated ware, \$390; 2 cases optical goods, \$215.

Bombay: 2 cases watches, \$260.

Bremen: 1 case plated ware, \$150; 1 case plated ware, \$155; 3 cases watches, \$2,750; 4 cases jewelry, \$241.

Calcutta: 23 cases clocks, \$542; 102 cases clocks, \$2,685.

Callao: 1 case clocks, \$225.

Cartagena: 1 case watches, \$228.

Curacao: 1 case silverware, \$174.

Cienfuegos: 7 cases plated ware, \$638.

Genoa: 1 case plated ware, \$130.

Hamburg: 3 cases clocks, \$181; 3 cases jewelry, \$615; 12 cases jewelers' sweepings, \$400.

Havana: 24 cases clocks, \$239; 18 cases clocks, \$350; 1 case jewelry, \$213.

Havre: 1 case jewelry, \$400; 2 cases stereoscopes, \$200.

Kingston: 11 cases clocks, \$177; 1 case watches, \$143; 3 cases jewelry, \$146.

Lisbon: 38 cases clocks, \$580.

Limerick: 4 cases thermometers, \$475.

Liverpool: 120 cases clocks, \$1,007; 2 cases silverware, \$481; 4 cases jewelry, \$810; 178 cases clocks, \$7,658; 2 cases optical goods, \$119; 1 case silverware, \$375; 1 case jewelry, \$600.

London: 7 cases plated ware, \$211; 1 case watch cases, \$306; 14 cases optical goods, \$3,706; 25 cases watches, \$1,965; 2 cases scopes and views, \$256; 1 case jewelry, \$10,000; 10 cases watches, \$3,156; 2 cases watches, \$1,095; 91 cases clocks, \$2,898; 3 cases watches, \$225; 7 cases optical goods, \$2,435; 7 cases watches, \$1,178; 2 cases silversmiths' supplies, \$265.

Las Palmas: 1 case clocks, \$185.

Manila: 1 case watches, \$188; 1 case jewelry, \$105; 12 cases clocks, \$371.

Melbourne: 59 cases plated ware, \$4,108; 521 cases clocks, \$9,794; 3 cases watches, \$136; 13 cases optical goods, \$1,938.

Montevideo: 5 cases plated ware, \$605; 49 cases clocks, \$589.

Naples: 3 cases jewelry, \$5,721.

Nassau: 4 cases plated ware, \$107.

Oporto: 50 cases clocks, \$639; 7 cases clocks, \$120.

Rio de Janeiro: 182 cases clocks, \$2,596.

Santos: 10 cases clocks, \$673; 3 cases plated ware, \$127; 1 case jewelry, \$148; 5 cases watches, \$245; 1 case optical goods, \$114.

Southampton: 115 cases clocks, \$4,025; 29 cases clocks, \$1,015.

Sydney: 98 cases clocks, \$2,144; 14 cases plated ware, \$816; 82 cases clocks, \$2,195.

Vera Cruz: 27 cases clocks, \$257; 6 cases plated ware, \$125.

Victoria: 3 cases clocks, \$102.

Zurich: 2 cases watches, \$100.

From an Appreciative Subscriber.

NEWARK, N. J., Jan. 30, 1908.

Editor THE JEWELERS' CIRCULAR—WEEKLY:

I have been a subscriber of your paper for the past 18 years, and I find it a most valuable magazine. I have been much interested in the paper ever since I subscribed for it; and more particularly since the late financial depression set in, as I find more than \$2 worth of value in each issue. I do not see how any jeweler can do without THE CIRCULAR—WEEKLY, as it seems to me impossible to pass one of its pages unnoticed and without gleaning some valuable information from its columns; and as the contents of each issue keeps the trade well posted, I do not think there is a better conducted trade paper than the one you issue.

Believe me to be, yours respectfully,

BENJAMIN J. MAYO.

TO MAKE "SOLID GOLD" MEAN TEN KARAT

Executive Committee of the A. N. R. J. A. Will Try to Amend National Stamping Act to That Effect—Various Subjects Discussed at Cincinnati and Banquet Enjoyed.

CINCINNATI, O., Feb. 1.—The executive committee of the American National Retail Jewelers' Association was in session at the Sinton Hotel, this city, Jan. 28 and 29, for the purpose of arranging a programme for the convention to be held in this city next August. Subjects brought up for discussion during the meeting included, "A Parcels Post," "Amendments to the National Stamping Law," and "State Laws on Railroad Watch Inspection."

Most of the time devoted to discussion was spent on the subject of the standardization of "solid gold." An act will be drafted and sent to Washington for introduction in Congress next week defining "solid gold." Confidence was expressed by the committee that it will pass the present session, but it was stated, as a reason for the present secrecy, that giving out the plans now would arouse antagonism in certain quarters and give the opponents of the bill an advantage. The bill will prohibit the stamping of the words "solid gold" on any article or the use of the words on any tag or card attached to articles of less than 10 karats gold. This would mean that not less than 10½ of the mass from which the article was made must be of pure gold.

Secretary Radabaugh, in his remarks on the subject, said: "Marking such articles 'solid gold' would not be a misrepresentation, as there is not and never has been any standard for 'solid gold' in this country, and much of the jewelry and other articles sold for 'solid gold' contain much less than 10 karats." The purpose of the bill, he stated, is to create a standard. This bill, he said, is not in the interest of the retail jewelers, but is essentially a measure for the protection of the public.

At the close of the morning session, Jan. 29, the committee was entertained at lunch in the Business Men's Club by the Gruen National Watchcase Co. Wednesday afternoon closed the business meeting.

Six members of the executive committee were present. They were: Mack A. Hurlbut, Fort Dodge, Ia.; Ira M. Radabaugh, Hastings, Minn.; Max Jennings, St. Clair, Mich.; John P. Archibald, Blairsville, Pa.; R. C. Bernau, Greensboro, N. C., and R. D. Worrell, Mexico, Mo.

The next annual meeting was set for Aug. 4, 5, 6 and 7, at the Hotel Sinton, Cincinnati. This will give an opportunity for those interested to attend the meeting of the American Association of Opticians, which takes place in Philadelphia the week following.

It is the aim of the American National Retail Jewelers' Association to bring the retailer, the jobber and the manufacturer together, believing that by friendly intercourse many trade abuses can be remedied. Ira M. Radabaugh will have charge of organization work during the coming year.

The committeemen put themselves on record as endorsing a uniform State stamp-

ing law for all States, the same to conform with the National stamping law, and will work to that end.

In regard to an exposition to be held during the meeting, the National Association agreed to leave it to the Cincinnati retailers and jobbers to conduct one if they saw fit, but declined to receive any financial benefit therefrom.

On Wednesday evening an elaborate banquet was tendered the members of the committee at the Palace Hotel by the local jobbers, manufacturers and local retail jewelers' association. About 75 participated in the affair. Jacob Dorst, of the Dorst Co., brought much credit upon himself as toastmaster of the occasion, and as a preliminary to the other proceedings was presented with a handsome silver loving cup by George Gruen, in behalf of the entertainment committee.

The guests enjoyed the following menu:

Blue Points.
Celery.
Consomme in Tasse.
Salted Almonds. Olives. Pickles.
Baked Erie White Fish.
Potato Croquettes.
Roast Tenderloin of Beef.
Mushroom Sauce.
French Peas. Cauliflower.
Maraschino Sherbet.
Roast Turkey, Cranberry Sauce.
Sweet Potatoes au Glacé.
Waldorf Salad.
Vanilla Ice Cream. Assorted Cakes.
Roquefort Cheese. Toasted Crackers.
Coffee. Cigars.
"Wet Goods."

A very worthy response, "Out of the West," was given in a most pleasing manner by Mack Hurlbut, Ft. Dodge, Ia., the president of the American National Retail Jewelers' Association. J. P. Mullally, president of the Indianapolis Association, talked about "Jewelry and Jewelers," and Fred Pieper, president of the local association, gave an enlivening talk on "Life and Trade in Old Kaintuck." Otto C. Lightner, the new secretary of the Ohio Retail Jewelers' Association, told a number of interesting stories about "Some Jewelers I Know." J. W. Anderton, Dayton, O., brought the regular programme to a close with "My Opinion of the Crowd." E. Wagner brightened the programme considerably with illustrating "Some German Poems," as well as giving some very fine musical numbers.

R. F. Simmons Co., Attleboro, Announces Payment of Substantial Dividend to Its Employees.

ATTLEBORO, Mass., Feb. 3.—The following notice of an employees' dividend was given by The R. F. Simmons Co. to its employees last week.

Notwithstanding the severe financial panic which in October last burst upon the country like a cyclone, and left in its track a general stagnation of business, we closed the old year with a satisfactory showing. It is, therefore, with some gratification that we are able to announce that at a meeting of the directors of our company, held Jan. 20, it was voted to pay an employees' dividend of five per cent. on the total wages paid from July 1, 1907, to Jan.

1, 1908, to those who have fulfilled the original conditions that apply to our profit-sharing plan.

This is the 12th semi-annual employees' dividend paid by us in cash and is the largest in amount heretofore declared.

The total wages paid from July 1, 1907, to Jan. 1, 1908, were \$119,260.24. Five per cent. of this amount equals \$5,963.01 as the employees' dividend. Your wages for the period mentioned are noted on cards accompanying this letter and your dividend of five per cent. thereon is herewith handed you in cash. Kindly return both the old and new cards to the office as soon as you have verified the figures and be sure to sign the new card.

Now, what can we say for the new year upon which we have just entered? Certainly the outlook is not what we would like it to be, and yet the answers we have received from inquiries sent to every section of the country are far from discouraging. No one, we think, expects the Spring business to equal that of recent years, but with the average crops last Autumn, and the advanced prices therefor, it is generally believed we have a desirable foundation for an average year's business. In fact, were it not for the Presidential election, which comes this year, we should not hesitate to predict such a result.

However, we face the situation with determination and ask only that unitedly, and with courage, we work for one purpose, namely, the securing of our full share of whatever business is obtainable.

R. F. SIMMONS Co.

Creditors File Bankruptcy Petition Against Leroy D. Braman Missing Attleboro, Mass., Jeweler.

ATTLEBORO, Mass., Feb. 3.—The Manufacturing Jewelers Board of Trade, representing the creditors of Leroy D. Braman, the jobbing jeweler who disappeared from Attleboro Nov. 20, filed in the Bankruptcy Court in Boston, last week, a petition asking the court to take charge of the business of the missing man in Attleboro. The petition will be acted upon some time this month and a trustee in bankruptcy is expected to be appointed to settle matters in behalf of the creditors. The board will ask that an Attleboro man be named as trustee.

It had been understood, even among his creditors, that when Braman left Attleboro he had a large amount of money on deposit, and it was considered strange that it should have been left intact when he disappeared. It was learned, however, that up to last Saturday there was less than \$200 in the bank to his credit, and a great part of this came to his offices since he left town. It is believed that there was a small sum, less than \$100, in the bank when he left.

Saturday morning execution was obtained by two creditors against Braman's estate from the Attleboro court. The largest amount was for \$470 and was the claim of the Ostby & Barton Co., of Providence. When return of papers was made to the court it was learned that but \$195 was on deposit.

It is stated that the affairs of the estate of the late George Asa Dean, head of G. A. Dean & Co., in which Braman had a power of attorney, were investigated a few days ago and it was found that a sum of money had been diverted in some manner. Braman's relatives have deplored the publicity the case has received and rejected an offer on the part of Maine newspaper men to arrange a systematic publicity campaign to help find him.

H. U. Seaman, of the H. U. Seaman Co., Washington, Pa., has the sympathy of his friends in the trade owing to the recent death, at Los Angeles, Cal., of his father, Thomas Seaman.

Look Out for This Clever Flim Flammer, Who Swindled Cincinnati Jeweler Out of \$800 on Short Change Trick.

CINCINNATI, O., Jan. 29.—A clever "flim flammer" and short change artist is at work, and though he has one victim in his city who is known, there may be more. The police have not caught him yet and it is believed that he has gone to another location to work his trick. His victim here was George G. Rekart, 1533 Vine St., who was swindled out of \$800 worth of diamonds.

About lunch time Saturday a well-dressed and well-appearing young man of about 28 or 30 years, called at Rekart's store and asked to see some diamonds. He said he wanted four stones, which he would like to have set as earrings for his mother. The jeweler did not have in stock just what the young man seemed to be looking for, but did have four stones he had just gotten from Joseph Pieper, of F. Pieper & Co., Covington, Ky. On these he set a price of \$825, which was satisfactory to the young man. Mr. Rekart then called up Mr. Pieper by telephone and asked if the sale would be all right, and was assured that it would be.

The young man thought he hadn't enough money with him to pay for the stones and would have to go to the bank to get a check cashed, so asked the jeweler to lay the stones aside until he returned. After thinking a moment he asked Mr. Rekart to bring the stones and go with him to the bank, so to save time.

Upon arriving at the City Hall Bank, the stranger, as he started toward the cashier's window, put his hand in his pocket and remarked that he might have more money with him than he first thought. At the same time he pulled from his pocket a roll of bills, saying, "I believe I have enough." He laid out a \$500 bill, three \$100 bills, and some smaller ones.

"There," said he, as he handed them to the jeweler, "I believe you'll find that to be all right, but you had better count them yourself." This Mr. Rekart did, and found the amount was \$1 short. The stranger then took the money, and after again counting it, said, "That's right now," and handed out a silver dollar, which he placed on top of the bills, around which this time he had placed a rubber band. He then handed the money to Rekart, who handed over the diamonds and placed the money in his pocket.

When the jeweler reached his store he found he had only \$25, the four bills of the large denomination having been slipped out by the stranger. The police, who were notified, think the swindler answers the description of a man who robbed some jewelry firms here about three years ago, but by a different method.

Swindler Gets Diamonds from Pittsburg Jeweler by Clever Sleight-of-Hand Game.

PITTSBURG, Pa., Jan. 30.—A sleight-of-hand game was cleverly worked yesterday on a boy clerk in the store of John Bain, 1014 Wylie Ave., and as a result Mr. Bain is mourning the loss of diamonds valued at

\$900, for which he received the sum of five dollars. Jewelers are warned to be on the lookout for this swindler.

The man entered the store in the morning and asked to see some diamonds that would run up to three figures in price. The prospective customer gave his name as Leon Stein, described the kind of goods that he wanted and said that he would call again.

Later he sauntered into the store and displayed a large roll of bills, with one of \$500 denomination. Mr. Bain allowed the stranger to take the diamonds, after he had suggested that the boy go to the bank to get the money changed. This the jeweler suggested would be a good thing to do. So Stein took the money, rolled it up tight, placed it in the boy's hands and, telling the lad not to let go of it for a minute and not to stop on the way, started him off for a nearby bank.

On the pretense that he wanted to put the boy on a car, in order that it would not be safe to send him after change alone, Stein left the store with the youngster, with the diamonds in his pocket, and never returned. On his arrival at the bank the boy discovered that not one of the bills he had was of larger denomination than one dollar and went back to the store and reported the matter. By that time Stein had made good his escape with the diamonds.

The police bureau was immediately notified and a description of the man given, but no trace of him has been found.

List of Articles Stolen from the Window of Sculler Bros.' Store, Columbus, O.

COLUMBUS, O., Jan. 31.—A thief, who is supposed to have concealed himself somewhere in the store before closing, or who entered the front door with a duplicate key, robbed Sculler Bros.' jewelry store Tuesday night of stock valued at more than \$900. The goods were all on display in the window. The window is enclosed inside, and a pane of glass was broken out, through which the thief worked.

The window display is left until 9 o'clock in the evening, when one of the owners comes down to remove it to the safe and turn out the window lights. Earl Sculler happened to come down about an hour and a half earlier Tuesday night and found the window lights out. When he unlocked the door to enter to investigate, he found it fastened—propped shut with a stove zinc—and had to force an entrance. The thief left by a back door, the key of which was left sticking in the keyhole on the inside. An investigation disclosed the theft.

The following were stolen: Thirteen diamond rings, valued from \$6.25 to \$82.50, total value \$521.50; three brooches, one diamond each, \$20, \$25 and \$30; cluster brooch, diamonds and pearls, \$30; three pairs cuff buttons, each set with one small diamond, total value \$26.50; one pair cuff buttons, Masonic emblem; thirteen watches, valued at \$209.25.

The number of watches and cases, of which the proprietors had record, are: 16-size hunting case Keystone solid gold, 4894260, with Rockford 17-jewel movement, 705182, firm name on dial; 18-size open face plain 20-year, 5195389, with Elgin 21-jewel Father Time movement, number unknown; 12-size hunting engraved Keystone, 20-year,

6869185, with Elgin 7-jewel, 10556112; 18-size Rockford 17-jewel, 606890, in cheap case. There were also the following cases, nearly all containing movements, numbers of latter unknown: 12-size hunting engraved Crescent, 25-year filled, 1336573; 6-size hunting, North American Watch Co., 20-year, 973165; 16-size open face engraved, North American Watch Co., 20-year, 903-081; 16-size hunting engraved Fahys, 20-year, 735459.

Recent Decisions by General Appraisers on Jewelry and Kindred Lines.

Decisions of the Board of United States General Appraisers in cases involving duties on jewelry and kindred lines have been announced in the last week as follows:

FOIL-BACK JEWELS.—Protest of Morris Goldberg (New York). Protest sustained as to foil-back jewels. G. A. 6380 (T. D. 27420) followed.

JEWELRY—CELLULOID COMBS.—Protests of Samstag & Hilder Bros. (New York). Celluloid combs ornamented with gold-plated metal scrollwork, were held to have been properly classified as jewelry. G. A. 6658 (T. D. 28391) followed.

AGATE BEARINGS—IMITATION PRECIOUS STONES.—Protests of Albert Lorsch & Co. (New York). Protests overruled as to agate bearings on the authority of United States v. Lorsch (T. D. 28513), and sustained as to imitation precious stones on the authority of G. A. 6089 (T. D. 26555), G. A. 6155 (T. D. 26723), and G. A. 6167 (T. D. 26770).

AGATE BEARINGS.—Protest of Albert Lorsch & Co. (New York), protests of McGrew Computing Scale Co. (St. Louis) and protests of Toledo Computing Scale Co. (Toledo). Assessment affirmed as to agate bearings.

JEWELRY.—Protest of A. Steinhardt & Bro., protest of F. W. Woolworth & Co., protest of Syndicate Trading Co. and protests of H. Wolff & Co. (New York). The articles were held to have been properly classified as jewelry.

ORNAMENTS—PINS—TOY JEWELRY—IMITATION PRECIOUS STONES—KEYSTONES—AMETHYST BEADS.—Protests of D. Lisner & Co. et al., protests of Albert Lorsch & Co. and protests of H. Wolff & Co. et al. (New York). The protests related to a large variety of articles. The importers' contentions were sustained as to various ornaments, pins, toy jewelry, imitation precious stones, keystone, amethyst beads, etc. G. A. 6658 (T. D. 28391), G. A. 6374 (T. D. 27382), G. A. 6376 (T. D. 27390), G. A. 6089 (T. D. 26550), G. A. 6155 (T. D. 26723), G. A. 6167 (T. D. 26770), and G. A. 5811 (T. D. 25664) followed.

In order to prove their confidence in the stability of diamond prices, Cyrus Price & Co., diamond cutters, of 170 Broadway, give a guarantee with every bill of goods, that if the market prices of diamonds should be reduced before the maturity of the bill they will make up any difference in the price between the then prevailing market rates and the prices at which the diamonds were sold. This guarantee will allay any fears the retail jeweler may have as it insures him against any possible loss.

GORHAM SILVER

SOME NOTABLE ACCESSIONS

¶ It is now generally recognized by discerning Jewelers that there is an increasing demand on the part of the average purchaser for such small articles of silverware as, by reason of their practical utility, their decorative appearance and their moderate cost, may be regarded as suitable for gifts.

¶ The Gorham Company, therefore, have taken pains to largely, but discriminatingly, increase their line of small wares despite the fact that this has always been notable for the complete and varied nature of its character.

¶ It will now be found that for diversity of range, attractiveness of design, and excellence of workmanship it is without a parallel.

THE GORHAM COMPANY,



CHICAGO,
137 Wabash Ave.

Silversmiths and Goldsmiths

Fifth Avenue and 36th Street, New York.

BRANCHES:

NEW YORK,
23 Maiden Lane.

SAN FRANCISCO,
Temporary Office:
1103 Broadway, Oakland, Cal.

LONDON,
Ely Place.



WORKS: Providence and New York.

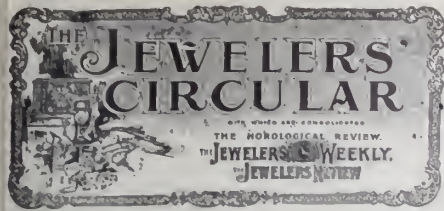

PUBLISHED EVERY WEDNESDAY BY

THE JEWELERS' CIRCULAR PUB'G CO.

L. J. Mulford, Pres. & Treas. V. S. Mulford, V. P. & Sec.

11 JOHN ST., COR. BROADWAY, NEW YORK.

TELEPHONE: CABLE ADDRESS: JEWELAR, NEW YORK.
1149 CORTLANDT.

VOL. LVI FEBRUARY 5, 1908. No. 1.

Subscription in United States and Mexico, \$2.00
 Dominion of Canada, 3.00
 Other Countries in Postal Union, 6.00
 Single Copies, .10

Remit by check or money order. Remittances in money are at sender's risk.

Paris Pearl Market	145	How to Meet the Competition of the Mail Order House (Continued)	225
National Import and Export Statistics.....	147	Another Mechanical Show Window.....	227
New Enterprises	147	The Hustler of To-day.....	227
Imports at New York.....	147	Original Window Displays for Jewelry.....	228
Programme of the Indiana Jewelers' Association	147	Start Your Own Rogues' Gallery.....	228
Important Arrest by Police in New Haven..	147	A Representative Retail Jewelry Store of Lima, O.	229
Gold Bars Withdrawn and Exchanged.....	147	Knowing One's Customers.....	229
Silver Market	147	The Way of the Enterprising.....	229
Syndicate Reiterates in Another Cable Its Determination to Maintain Prices.....	149	Vigorous Advertising of Diamonds Marks the Opening of the New Year.....	230
A. L. Hodes Goes Into Bankruptcy.....	149	Business Philosophy	230
Jewel Presented to Past Ruler of the B. P. O. E.	172	Easter Advertising Suggestions for the Retail Jeweler	231
Jewelry Considered as an Investment by People of the Levant.....	172	Business Man in Advertising.....	232
Patent Department	177-179	How Some Retail Jewelers Supplemented Their Newspaper Advertising During the Holiday Season	234
Practical Points on the Lathe.....	195-207	Workshop Notes and Queries.....	235
Regulation of the Watch Through the Button	207	The Preparation of Chemically Pure Gold..	237
A Catechism of the Lever Escapement (Continued)	209-213	A Noted British Artist's Work in Glass Portraiture	239
A Clock Case Constructed of Wood from Various Parts of the World.....	213-215	Toby Jugs and Their Popularity in the Past.	241
Useful Tools for the Watchmaker's Bench.	215-219	Frankenthal Porcelain	243
Isochronism	219-221	The Difference Between Earthen Ware and China	245
The Clock in the Cathedral at Besancon.....	221	Etching on Glass	245
Store Illumination and Advancing Science..	222-225		
February Business Getting.....	225		

Index to News and Special Articles.

Modern Art Jewelry; Original Designs Drawn Especially for The Circular-Weekly—Illustration on page 1; text on page	105
Essential Principles to be Considered in Judging Applied Design	67
The Municipal Plate of the Cities of Europe.	69-78
How the Tourmaline Mines of Burma Are Worked	78
Casting a Bronze Statue.....	78
Progress Made by Class in Jewelry Manufacturing at the Newark, N. J., Drawing School	79
The Influence of Style in the Silversmith's Craft	80-97
An Artistic Monstrance Presented to the Westminster R. C. Cathedral, London.....	97
The Trend of Fashion in Jewelry.....	99-105
Artistic Jewelry as a Feature of the Cover Design	105
Neglect of Flaxman's Grave Deplored.....	105
Gold and Silver Treasures of the Royal House of Hohenzollern	107-113
Parliamentary Regalia of the Orange River Colony	115
Jewelry Imports and Exports.....	117-119
Reigning Paris Fashions	119
Repoussé Work and Chasing (Continued)....	121
Cameos	123
Banquet of the Jewelers League.....	125
Death of Norman Galt	127
Career of the Late Jonathan A. Briggs.....	127
The News from London.....	129
Annual Meeting of The Jewelers Board of Trade	131-133
Jewelry, Clocks, etc., Exported from New York	133
Committee of the A. N. R. J. A. Hold Important Session at Cincinnati.....	134
R. F. Simmons Co., Attleboro, Announces Payment of Substantial Dividend to Its Employees	134
Bankruptcy Petition Filed Against L. D. Braman	134
Look Out for This Clever "Flim-Flammer" Who Swindled Cincinnati Jeweler Out of \$800	135
Swindler Gets Diamonds from Pittsburg Jeweler by Clever Sleight-of-Hand Game.....	135
List of Articles Stolen from the Window of Sculler Bros.' Store, Columbus, O.....	135
Recent Decisions by General Appraiser on Jewelry and Kindred Lines.....	135
Games Rolled by Jewelers' Bowling League..	143
Bids Received and Contracts Awarded by Government to Supply Various Articles....	145
Will of the Late George B. Barrett, Pittsburg, Pa.	145
M. M. Huck Goes Into Bankruptcy.....	145
Involuntary Bankruptcy Petition Filed Against Stephen F. Bell.....	145

Our 39th Anniversary. WITH this issue THE CIRCULAR-WEEKLY celebrates its 39th Anniversary, and the number, we feel, is worthy of an occasion so important to ourselves and our subscribers. This number, which contains 254 pages, is not only one of the largest that has ever been issued by any publication of its character in the jewelry trade, but both as a magazine and as a volume of interest to the jeweler, fittingly represents the progress of the times and the importance of the jewelry trade in the commercial world. The amount of advertising it contains establishes a record also, being the largest we have ever published.

Beginning with the beautiful front cover and ending with the last page of the book, the issue will be found interesting and instructive to the subscriber, no matter what his line may be, while the retail jewelry merchant will find a number of articles which will be a decided help to him in his business and trade, and others that will give him points which he can directly apply to his business and also give him information of his craft which has never before been placed at his disposal. To enumerate or describe the many interesting features of this issue would require more space than is at our disposal, but an idea of its contents may be had at a glance by the subscriber who casts his eye down the index to news and special articles, which appears on this page.

That we have been able to produce such a handsome number has been due as much to the support and encouragement given to us by the trade as to the individual efforts made by the editors and publishers. While thanking our subscribers and friends for the encouragement and assistance which they have already given us, we wish to take this opportunity to request the same support in the future as in the past, with the assurance that it will be followed by increased efforts on our part to serve the trade as only a prosperous journal can—disseminating interesting and instructive information, fighting the trade's battles and defending its principles, and through

a news service that is constantly growing in extent and perfection, keeping every member of the trade in close touch with everything that is happening that in any way affects or relates to the members of his craft, no matter in what part of the country it may occur.

A Good Law Unjustly Criticised. OUR contemporary, *The Metal Industry*, a bright and instructive publication devoted to work in the non-ferrous metals, in its January number calls attention to the fact that though the National Stamping Act went into effect June 13 last, there has as yet, in the first six months of its existence, been not a single conviction under it of a manufacturer or dealer who has violated its provisions by making and shipping articles of gold or silver improperly stamped as to quality; therefore, our contemporary draws the conclusion that the law has failed to accomplish its purpose, which, it states, was both to protect the public against swindlers and to aid the honest manufacturer. In fact, this failure is characterized even as "dismal" by our contemporary, which seems to think that because it has not begun to fill the jails with malefactors the statute is practically dead, or, as it puts it, "is of no more service than a live man under a mountain. Technically both are in actual existence, but neither is doing very well."

We would call to the attention of the editors of *The Metal Industry* and to the members of the trade who have thought that the law should have been followed by a number of prosecutions, that proceedings under this statute necessarily must be slowly and carefully prepared, but that after a test case is made the prosecutions of complaints will be just as quick under this part of the federal statutes as under any of the others which at present keep the district-attorneys' offices busy.

We would also call attention to the fact that the main aim and purpose of the law has been accomplished, namely, that it was enacted as much as a preventative as a punitive measure, and the mere fact that the law is on the statute books has resulted

FIRST HANDS



CROSS & BEGUELIN

Importers and Cutters of Diamonds and Precious Stones

3 Rue de Meslay, PARIS

Telephone,
480 John

31 Maiden Lane, NEW YORK



The Silent Appeal

H. A. KIRBY

FINE
GOLD
JEWELRY

PROVIDENCE
NEW YORK

HAVE YOU EVER REFLECTED ON HOW A PRETTILY WROUGHT AND EFFECTIVELY DISPLAYED DESIGN WILL UNCONSCIOUSLY INFLUENCE A PURCHASE? HOW FIRST IT EXCITES ADMIRATION IN THE INDIFFERENT SPECTATOR, THEN IRRITATES THE DESIRE TO POSSESS, AND FINALLY BY ITS VERY IRRESISTIBILITY COMPELS HIM TO PURCHASE? IN EFFECTING SUCH A SALE, ONLY A FEW CONVENTIONAL REPRESENTATIONS ARE NECESSARY BY THE JEWELER, WHOSE PROFITS ARE A JUST REWARD FOR HIS SHREWDNESS IN EQUIPPING HIMSELF WITH SUCH JEWELRY. WE MAKE IT IN AN INEXHAUSTIBLE VARIETY—AT MODERATE COST.

in the abandonment of the bulk of such dishonest marking of jewelry as was not done because the manufacturers themselves either desired it or wished to continue it, but because there being no law to forbid the practice they had continued it simply because their competitors would not stop. The fact that the acts in question were made illegal and applied to all alike gave these manufacturers an excuse to quit false stamping of jewelry, which brought them neither honor nor profit.

The criticism of our contemporary that the law cannot be as effective as the hall-marking statutes of Great Britain and the other European nations, which compel all articles of precious metals to be assayed and marked, is undoubtedly correct, but such a law is impossible of attainment in this country, even as a State statute, and it would be a silly waste of time to try to get through the National Legislature any law whatsoever on the subject, because it is more than doubtful it would ever be given consideration by a committee not alone having any chance of being passed by either the House or Senate. The National Stamping Law went further in the way of regulating interstate commerce than any act of its character that had preceded it, and it is safe to say that it was considered both by those who were back of the measure and the committees in both House and Senate in charge of it, as affording a maximum of protection on these lines that it is within the power of Congress to grant to the public.

Beware This "Short Change" Swindler. THE reports received from various sections of the country last week indicate that a clever swindler, known in common parlance as a "short change artist" or "flim-flammer," is at large, and as at least two jewelers are known to have been among his victims it therefore behooves the members of the trade to be on the lookout for this man or others who may try the same game. With the deftness and rapidity of movement worthy of a prestidigitator this man is apparently able to take from a dealer money which he has paid to him, directly under his eye, so that more than ordinary precaution must be exerted where the jeweler believes he has encountered the swindler in question.

One of the main features of this man's operations has been the use of a \$500 bill with other bills of big denomination, which seem his main implements of trade, and perhaps this might be one of the signs for which the jeweler should look. The size of the bill not only serves to disarm suspicion and establish the reputation of standing of the customer, but it also serves to make it very easy for the swindler to get back the bulk of his money without showing any material difference in the size of the roll of bills offered and that finally given to the merchant on whom he is playing his tricks.

One of the safest ways for the dealer to protect himself against a "short change" man is to count his money before he parts with his goods no matter how many times he may have counted it before or how many times it has been counted in his presence.

New York Notes.

Fred Howard, of F. M. Whiting & Co., N. Attleboro, was in New York last week for a few days.

Chas. S. Stiff, Little Rock, Ark., is in New York for a visit, stopping at the Waldorf-Astoria Hotel.

Erle Sheppard, manufacturer's agent, 53 Maiden Lane, was in Philadelphia last week on a business trip.

M. J. Baer, of the Attleboro Mfg. Co., Attleboro, Mass., has been visiting in town during the past week.

Henry A. Kirby, of Providence, R. I., spent last Wednesday at the New York office, at 9 Maiden Lane.

Irving Schwartz, representing L. Barnett & Co., 13 Maiden Lane, has announced his engagement to Miss Lewengood, of this city.

Col. John L. Shepard, New York manager of the Keystone Watch Case Co., 21 Maiden Lane, has been kept at his home during the past week by a severe cold.

Albert Lorsch, of Albert Lorsch & Co., 37 Maiden Lane, accompanied by his wife, sailed yesterday on the *Kaiser Wilhelm II*. They expect to be in Europe some time.

Announcement is made of the approaching wedding of Sam Schafer, manager of the office of Sohn & Hyman, 47 Maiden Lane, and Miss Julia Rieger of this city. The wedding will occur Feb. 16.

Otto A. Schultz, of the Schultz Jerse-mann Mfg. Co., 105 Maiden Lane, who had been seriously ill for three weeks, is again able to be at the office. He has started for a western trip in the interest of his concern.

A discharge in bankruptcy has been granted by Judge Holt in the United States District Court to Jacob A. Moller, New Rochelle. Mr. Moller filed schedules in bankruptcy in November, showing liabilities of \$6,672.

William Cooper, of Cooper & Forman, who has been sick in a hospital at Sumter, N. C., for about a week, has recovered sufficiently to resume his trip. He left New York on a trip and was taken ill and went to the hospital.

Jules F. Schuman, Jr., with the William Kinschurf Co., who has been confined at the Murray Hill Sanitarium for the past four weeks, where he underwent an operation, is expected out this week, and will call on his trade shortly.

Jules H. Lacroix, who for the last 15 years has been the selling agent for the New England Watch Co., 35 Maiden Lane, has started in business for himself as a wholesale dealer in watches, movements and cases. His office is at 35 Maiden Lane.

Benjamin V. Arnstine, president, and Harry W. Arnstine, vice-president of the Arnstine Bros. Co., Cleveland, O., were among the visitors at the office of THE CIRCULAR-WEEKLY last week. They stopped at the Hotel Astor during their stay in the city.

Theodore L. Lyons, president of the Lyons Gem Co., 35 Maiden Lane, who has represented the concern since the date of its incorporation, Nov. 1, 1902, has purchased the interest held by his sister, Miss Isabel A. Lyons, in the company, which consisted of 68 of the 250 shares of the

corporation, and will hereafter manage the business.

The Diamond Capped Bearing Co. has been incorporated under the laws of the State of New York to manufacture jewelry bearings, miter pivots, jewelry drills, etc., with a capital of \$15,000. The incorporators are: Wales R. Stockbridge, Herbert J. Bickford and Franklin R. Magee, all of New York.

The Keystone Watch Case Co. will issue 10,000 additional shares of capital stock to stockholders of record Jan. 31. Stockholders will be given the right to subscribe at par to the extent of 20 per cent. of their holdings. The right to subscribe will remain open until Feb. 20. Subscriptions are payable in three instalments, as follows: First instalment, \$10 per share, March 1; second instalment, \$30, June 1, and third instalment, \$30 per share, Aug. 1.

In speaking of the Louis Witsenhausen bankruptcy proceedings in a recent issue of THE CIRCULAR-WEEKLY it was stated that the committee of creditors recommended the acceptance of the 50 per cent. settlement proposed. This was an error, as the settlement on this basis was proposed by the debtor, and the committee made no recommendation or suggestion in connec-

This issue contains more advertising than was ever published in any previous number of THE JEWELERS' CIRCULAR during its 39 years of life.

tion therewith, but simply reported the conditions which their investigation disclosed.

The business of Howard & Co., retail jewelers, 576 Fifth Ave., has been placed in the hands of James C. Cannon, vice-president of the Fourth National Bank, as trustee. The liabilities of the firm are placed at about \$800,000. An extension of payment has been arranged in three equal payments, to be made in June, 1908, February, 1909, and August, 1909, 65 per cent. of the indebtedness. At the end of that time it is thought that the remaining 35 per cent. can be paid off. If this be impossible a further extension will be arranged.

A revised copy of the constitution of the Jewelers 24-Karat Club of New York City has just been prepared and is being sent to the different members. Special attention is called to the changes in Articles 2 and 8 and the addition of Article 13 of the club's constitution. The board of directors found it necessary to recommend these changes as there are quite a number of applications for active membership now on the waiting list. The booklet is bound in heavy dark brown paper and bears the emblem of the 24-Karat Club in the proper colors on the cover.

A verdict for \$5,000 has been granted to John W. Drummond, who was the plaintiff

in an action brought at the trial term of the United States Circuit Court, before Judge Hough and a jury. The suit was brought to recover \$25,000 for injuries alleged to have been sustained by the plaintiff in March, 1905, while he was crossing Fourth Ave., between 22d and 23d Sts. It was stated in the complaint that a motor delivery wagon carelessly driven by an employe of Tiffany & Co. ran the plaintiff down, and one of the wheels, it was said, passed over his right leg. Counsel for the defendant firm moved for an order to set aside the verdict and grant a new trial. The motion was denied.

A suit interesting to the jewelry trade on account of the facts involved was decided in favor of Aisenstein & Woronock, 22 Eldridge St., in the Supreme Court, Brooklyn, before Judge Jacox, Wednesday last, the action being against Etoro Penna and charged the defendant with conversion of jewelry worth \$690, which he had obtained on memorandum. The suit was brought for the plaintiff by Leopold Frank, manager of the Jewelers Protective Association, while Antonio Astarita appeared for Penna and set up in answer the claim that the memorandum transactions had been succeeded by sales after Penna had given promissory notes for the amount owed. Mr. Frank introduced evidence to show that Penna had given promissory notes on an open account of \$200, which notes were never paid, and when he had offered notes on the memorandum account these notes were refused, and the attorney claimed that Penna had admitted that they had been returned. The jury returned a verdict for the full amount in favor of Aisenstein & Woronock. It is said by the Jewelers Protective Association that a large number of other jewelers have claims of a similar nature.

Thieves gained entrance to the cellar beneath the store of Mrs. A. Hawkins, 727 Eighth Ave., Jan. 28, and with augers bored up through the floor and removed a square piece of planking, which gave them access to the space beneath a shelf in the display window. Thus it was possible to raise the woodwork supporting the jewelry and gather in the booty. Six pairs of skeleton diamond ear screws, valued at \$839, and two tie clasps worth \$14 were taken. The robbery occurred while the street was full of passing pedestrians, and it is thought the burglars were frightened away before they had completed their work. W. G. McDougall, manager of the store, in speaking to a CIRCULAR-WEEKLY reporter about the robbery, said that when he returned from lunch he noticed that the cards in the window were slightly disarranged, and on investigation discovered the robbery. One of the cards which had evidently been left by the robber in his hurry was soiled with finger marks. There was several thousand dollars worth of jewelry in the window, and if the thief had not been frightened away he would probably have obtained a more valuable booty. Both Mr. McDougall and Mrs. Hawkins are of the opinion that more than one man was connected with the burglary. In the cellar the robbers had placed boxes in such a position that by standing on them they were able to

(New York Notes continued on page 143.)

ESTABLISHED 1852

THE NASSAU BANK

Original Clearing House Member

Corner Nassau and Beekman Streets

NEW YORK

Title Guarantee and Trust Co.

176 Broadway (between John St. and Maiden Lane), New York

Capital and Surplus - - - - \$12,000,000

Deposits received subject to Check. Interest allowed. Letters of Credit issued. Drafts drawn on Great Britain and the Continent. All Banking Facilities afforded to Customers. Accounts of Jewelers are especially solicited.

Finance Committee in Charge of Banking Interests

E. T. BEDFORD, 26 Broadway
 C. H. KELSEY, President
 E. L. MARSTON, of Blair & Co., Bankers
 W. H. NICHOLS, General Chemical Co.

CHARLES A. PEABODY, President Mutual Life Ins. Co.
 JACOB H. SCHIFF, of Kuhn, Loeb & Co.
 JAMES SPEYER, of Speyer & Co.
 E. O. STANLEY, 2d Vice-President

BRANCH BANKING OFFICES: 196 Montague St. and 125 Remsen St., Brooklyn; 350 Fulton St., Jamaica; 67 Jackson Ave., Long Island City

The Market and Fulton National Bank of New York.

ORGANIZED 1852

81-83 FULTON STREET.

Capital, \$1,000,000.

Surplus, \$1,500,000.

PROGRESSIVE — CONSERVATIVE — SUCCESSFUL.

ALEXANDER GILBERT, President.
 R. A. PARKER, - Vice-President.
 T. J. STEVENS - - - Cashier.
 JOHN H. CARR - Asst. Cashier.

Invites the Accounts of Jewelers.
 Will extend every facility that good banking will justify

SAFE DEPOSIT VAULTS.

THE STATE BANK

376-378 GRAND STREET, NEW YORK

Capital and Earned Surplus, over \$1,500,000. Deposits over Fifteen Millions.

Offers a favorable market for short and long time jewelry and diamond paper.

The Mercantile National Bank

OF THE CITY OF NEW YORK

195 Broadway

Capital
\$3,000,000

FOUNDED 1850

Surplus
\$2,000,000

Conveniently located, and especially
equipped for the handling of ac-
counts of Merchants in the
JEWELRY TRADE

OFFICERS

SETH M. MILLIKEN, President

WM. SKINNER, Vice-President

EMIL KLEIN, Cashier

MILES M. O'BRIEN, Vice-President

ALFRED W. DAY, Assistant Cashier

GERRISH H. MILLIKEN, Vice-President

DIRECTORS

SAMUEL BOWNE.
WILLIAM F. CARLTON.
HAROLD A. HATCH.
EDWARD T. JEFFERY.
JOHN F. KEHOE.

JOHN G. LUKE.
GERRISH H. MILLIKEN.
JAMES E. NICHOLS.
BENJAMIN NICOLL.
MILES M. O'BRIEN.

CHARLES E. PERKINS.
DICK S. RAMSAY.
GEORGE H. SARGENT.
WILLIAM SKINNER.
WARNER VAN NORDEN.

SETH M. MILLIKEN.

F. W. WOOLWORTH.

THE LIBERTY NATIONAL BANK OF NEW YORK

139 BROADWAY



CAPITAL, SURPLUS AND UNDIVIDED PROFITS \$3,300,000

OFFICERS.

FREDERICK B. SCHENCK,
PRESIDENT.

DANIEL G. REID,
VICE-PRESIDENT.

CHARLES W. RIECKS,
2d VICE-PRESIDENT.

JAMES V. LOTT,
CASHIER.

FREDERICK P. McGLYNN,
ASST. CASHIER.

DIRECTORS.

GEO. F. BAKER.....President First National Bank, New York
E. F. C. YOUNG.....President First National Bank, Jersey City
ARTHUR F. LUKE.....Darr, Luke & Moore, New York
HENRY C. TINKER.....New York
J. ROGERS MAXWELL.....President Atlas Portland Cement Co.
D. G. REID.....Chairman Board Directors Rock Island System
E. C. CONVERSE.....President Bankers' Trust Co.
FRANCIS L. HINE.Vice-President First National Bank, New York

T. A. GILLESPIE....President The T. A. Gillespie Co., New York
CHARLES H. STOUT..Vice-Pres. Manhattan Trust Co., N. Y. City
CHARLES A. MOORE....Manning, Maxwell & Moore, New York
HENRY P. DAVISON...Vice-President First National Bank, N. Y.
CHARLES H. WARREN...Treas. Mutual Life Ins. Co., New York
FREDERICK G. BOURNE.....New York
AMBROSE MONELL....President International Nickel Co., N. Y.
FREDERICK B. SCHENCK.....President

New York Notes.

(Continued from page 139.)

reach to the window above. Detectives have been put on the case.

M. Gugenheim, 31 Union Sq., sailed recently for Europe on the *Kronprinzessin Cecilie*.

Myers & Gordon, watchmakers and engravers for the trade, have moved from 1368 Broadway to the Cockroft building, 71 Nassau St.

M. Goodfriend, of Goodfriend Bros., 13 Maiden Lane, sailed on the *Amerika* of the Hamburg-American Line last Thursday for Europe. He expects to be absent about a month.

Harry P. Yanz, who is well known in the trade through his connection with the Koshland & Italie Co., Philadelphia, Pa., has become a western representative for the Aikin Lambert Co.

The firm of Day, Clark & Co. has been incorporated under the laws of the State of New Jersey, with a capital of \$150,000. The incorporators are: Samuel Clark, Franklin Day and Irving G. Day.

The Lenox Watch Case Co. has succeeded S. Geltman & Son, 81 Chrystie St. The company will manufacture gold watches, cases and jewelry. The factory is at 17 Bedford St., Brooklyn.

John J. Bowen, who has been buyer for the jewelry department in the Bronx Store Co., Third Ave. and 163d St., is no longer employed in that capacity, the company having rented the department to an optician.

Arthur Totten is retiring from the firm of Robert Z. Block & Co., 170 Broadway, and will travel for Sansbury & Nellis in the west and south. The business will be continued under the same firm name at its present location by the other members of the firm.

A pearl necklace, worth \$5,000 or more, is lost and the police are trying to find it. A circular describing the necklace has been sent by Inspector McCafferty to every pawnshop in this city. It says that all advances will be paid by the owner. The lost necklace contained 72 pearls of fine quality and fairly even in size. The necklace was made by Tiffany & Co., and had a large diamond clasp.

Mrs. Elizabeth Griggs, a young widow, formerly of Cleveland, but now living on Morningside Heights, has brought suit against W. B. Shaw, head of the Barrett-Shaw Jewelry Co., which recently went into bankruptcy, to recover \$25,000, which, it is her contention, was obtained from her by undue influence to invest in the jewelry business. The case is in the special term of the Equity Division of the Supreme Court.

A rope of pearls containing 311 gems was sold at the Fifth Ave. Art Galleries Saturday afternoon by James P. Silo. The pearls were knocked down to J. A. Alexander for \$7,400. A pair of Oriental pearl earrings, weighing 109 grains, was obtained by J. Barnes for \$7,000, and a pearl necklace, with 63 pearls, weighing 452½ grains, was sold to C. E. Griswold for \$6,600. The total of the jewelry sale was \$75,151, that sold Saturday bringing \$64,260.

A fire which started in the quarters occupied by a manufacturer of agate ware, at 19 Cliff St., practically destroyed that building and did some damage to the building which fronts on 99 John St., in which the Ansonia Clock Co. has its offices. The damage done in the John St. building was caused by water. The building at 36 Gold St., occupied by several jewelry firms, became so hot that the firemen had to direct several streams upon the sides of the structure.

Adolph Marx, for many years connected with the firm of Kossuth, Marx & Co., died at his late home, 35 W. 127th St., Wednesday of last week. He was about 65 years of age. The business with which he was connected was started in January, 1874, by Kossuth and Jacob Marx. In February, 1875, Adolph Marx was admitted to the business. The business was later incorporated. Mr. Marx was the father of Mrs. R. F. Cary and E. Marx and a brother of Mrs. Hammel, Kossuth Marks and Jacob Marx.

The reports just issued by the United States Appraisers of the Port of New York show a marked falling off in the importations of precious stones and pearls, cut and uncut, for the month of January, 1908, as compared with the same month last year. The imports of cut precious stones and pearls in January, 1907, amount to \$2,650,393, as compared with \$207,230 for the same time this year. The uncut precious stones imported in January, 1907, amounted to \$935,707, while the imports last month showed \$106,226. The total for the month of January, 1907, amounts to \$3,586,100, as compared with \$313,456 for last month.

Paul Durand, at one time New York manager of the Baccarat Crystal Glass Co., Baccarat, France, and who is at the present time in business at Los Angeles, Cal., was before Judge Crane in General Sessions last week. He is charged with forgery and grand larceny, the total amount involved being about \$16,000. His bail was fixed at \$2,500, which was furnished. Two indictments against Durand were returned last week. Ex-Judge Whitman, who appeared for the defendant, contended that his client had contemplated fighting extradition proceedings. Mr. Durand says that the whole matter is the outcome of a business dispute relating to his commissions while manager of the glass company.

A man who gave his name as Henry Thompson, was held in \$1,000 bail to answer to the Court of General Sessions, by Magistrate Kernochan in the Essex Market police court, last week, on the charge of stealing a diamond ring from Philip Fink, 158 Bowery. According to the story told by the elder Mr. Fink, the man entered his establishment on Saturday night and asked to be shown a diamond ring. The ring was taken from the show case, and while the stranger was examining it the proprietor's attention was attracted to the rear of the store. When he turned again he saw his prospective customer running out of the door. A general chase followed, which resulted in the capture of the fleeing man. Mr. Fink places the value of the ring at \$125.

A second meeting of the creditors of Horwitz Bros., 196 Canal St., against whom a petition in bankruptcy was filed recently,

was held at the Broadway Central Hotel last Thursday. The creditors offered to accept a settlement of 35 per cent., part of which is to be on time, but the attorney for the Horwitz firm would not agree to the proposition. F. Hale is chairman of the committee appointed to effect a settlement. The debtors asked for a 20 per cent. settlement, 10 per cent. in cash and 10 per cent. in notes. The attorney for Horwitz Bros. has drawn up an agreement in settlement at 30 per cent., and is now circulating the paper among the creditors for signatures. The settlement offers 10 per cent. cash and 20 per cent. in notes at four, six, nine and 12 months.

Games Rolled by the Jewelers' Bowling League of New York.

The executive board of the Jewelers' Bowling League of New York held a meeting at the office of C. F. Wood & Co. last Thursday afternoon, at which time it was decided to hold the annual banquet at the Broadway Central Hotel on the evening of April 4, 1908. The chairman of the meeting appointed a committee of arrangements consisting of E. H. Dean, John Schierloh and H. Labouseur.

Following were the scores of the teams of the League in the games rolled last week:

H. W. Wheeler Co.....	852	800	824
vs. Jos. Fahys Co.....	863	791	769
N. H. White & Co.....	782	749	817
vs. Julius King Optical Co..	760	743	802
Cross & Beguelin.....	820	964	874
vs. Aikin-Lambert Co.....	877	812	883
Tiffany & Co.....	862	972	903
vs. A. A. Webster & Co.....	837	788	742

STANDING OF TEAMS.

	Won.	Lost.	High score.	Per cent.
N. H. White & Co.....	29	10	1,014	.743
Cooper Diamond Co.....	28	11	962	.718
Cross & Beguelin.....	27	12	1,017	.692
Tiffany & Co.....	26	13	969	.666
C. F. Wood & Co.....	24	12	943	.666
Jos. Fahys & Co.....	22	20	906	.524
Aikin-Lambert Co.....	23	22	967	.511
A. A. Webster & Co.....	14	28	916	.333
Julius King Optical Co....	9	33	889	.214
H. W. Wheeler & Co.....	8	25	922	.242
L. E. Waterman Co.....	6	30	852	.166

Albany, N. Y.

Levy B. Steele, formerly a jeweler of Hagerstown, Md., died of heart trouble at his home in this city recently. The deceased was 73 years old, was a clockmaker and silversmith in his early years and had been a resident of Albany for the past 20 years. He is survived by a widow and several children.

James M. Marshall, who has just finished a term for bigamy in the Philadelphia, Pa., county prison, has been placed in jail in Schenectady, charged with obtaining money on diamonds under false pretenses from Charles Beckelmann and M. J. Kennedy, Schenectady jewelers. Marshall squandered the money in speculation. He has operated under the alias of J. M. Williams, J. M. Alexander and John N. Marshall.

Arthur Everitt, Albuquerque, N. Mex., has donated to the Board of Directors of the National Irrigation Congress, two silver trophies, each 14 inches high and eight inches wide, to be awarded for the best exhibits of cereals and fruits at the Irrigation Congress and Industrial Exposition.

1851

THE JEWELERS' BANK FOR HALF A CENTURY
IN THE SAME LOCATION

1907

The Chatham National Bank

Broadway and John Street
New York

CAPITAL - - - - -	\$450,000
EARNED SURPLUS - - - - -	\$1,000,000

NOT CONNECTED WITH ANY OTHER INSTITUTION, OR CONTROLLED BY ANY SINGLE INTEREST,
INVITES THE ACCOUNTS OF MERCHANTS, FIRMS AND BUSINESS CORPORATIONS, AND IS
PREPARED TO EXTEND EVERY FACILITY CONSISTENT WITH CONSERVATIVE BANKING

Directors

GEORGE M. HARD, President
JOHN H. WASHBURN, Retired
SANFORD H. STEELE, Vice-President
General Chemical Co.
FRANK R. LAWRENCE, Attorney
DANIEL J. CARROLL, Lumber
JOHN D. VERMEULE, President
Goodyear India Rubber Glove Co.
G. P. MOROSINI, Banker

HENRY F. SHOEMAKER, Banker
WILLIAM B. CONRAD, White Goods
FRANKLIN S. JEROME,
Treasurer U. S. Finishing Co.
FRANK J. HEANEY, Exporter
SAMUEL WEIL, Capitalist
LEWIS COON, Real Estate
O. G. FESSENDEN,
of Hayden W. Wheeler & Co.,
Jewelers.

GEORGE M. HARD, President

WILLIAM H. STRAWN, Cashier

HENRY L. CADMUS, Assistant Cashier

Bids Received and Contracts Awarded by Government to Supply Various Articles.

WASHINGTON, D. C., Jan. 29.—The Bureau of Supplies and Accounts, Navy Department, has opened bids as follows:

Twelve comparing watches, Harris & Schafer, Washington, D. C., \$180; Henry C. Karr, Washington, D. C., \$306.

Eighteen boat clocks, Chelsea Clock Co., Boston, Mass., \$247.50; Vermilye & Power, New York City, \$369.

Twelve Binoculars, Price & Keen, Philadelphia, Pa., \$283.20.

WASHINGTON, D. C., Jan. 30.—The Bureau of Supplies and Accounts, Navy Department, has awarded the contract for 24,000 table knives for the Brooklyn Bureau of Equipment to F. S. Banks & Co., at \$1,836, and that for 24,000 each of forks and spoons to L. S. Barth & Sons at \$3,888.

WASHINGTON, D. C., Jan. 31.—The Bureau of Supplies and Accounts, Navy Department, is calling for proposals, until Feb. 11, for the following articles of silver-plated ware:

For the Flag Officer—Twenty-four table knives, 24 dessert knives, 12 butter knives, 12 nutcrackers, 6 fish knives and forks, 6 crumb scrapers, 6 soup ladles, 6 gravy ladles, 6 cheese scoops, 24 table forks, 36 dessert forks, 36 oyster forks, 12 pickle forks, 6 butter dishes, 24 table spoons, 36 dessert spoons, 36 teaspoons, 48 coffee spoons, 6 sugar spoons, 6 sugar tongs, 12 salt spoons, 6 mustard spoons, 6 20-inch meat dishes, 4 12-inch waiter's trays, 5 12-inch bread trays, 8 10-inch oval vegetable dishes, uncovered; 4 8-inch vegetable dishes, round, covered; 4 ice pitchers, 6 mustard pots, 6 castors without cruetts, 6 coffee pots, 4 2-pint teapots, 4 small teapots, 8 covered sugar bowls, 6 soup tureens, 3 carving knives, 3 carving forks, 3 steels.

For the Captain—Forty-eight table knives, 72 dessert knives, 6 fish knives and forks, 6 crumblers, 6 butter knives, 6 soup ladles, 6 gravy ladles, 6 cheese scoops, 6 sugar tongs, 12 sugar spoons, 18 salt spoons, 12 mustard spoons, 60 dessert spoons, 36 table spoons, 84 teaspoons, 96 coffee spoons, 18 pickle forks, 48 dessert forks, 48 dinner forks, 6 ice pitchers, 6 castors without cruetts, 24 high candlesticks, 12 soup tureens, 10 covered sugar bowls, 10 2-pint teapots, 10 small teapots, 8 cream pitchers, 9 gravy boats, 8 meat dishes, 6 bread trays, 6 waiter's trays, 12 butter dishes, 6 carving knives, 6 carving forks, 6 steels.

Silver-plated ware for wardroom—Forty-eight table spoons, 72 dessert spoons, 96 teaspoons, 12 sugar spoons, 24 salt spoons.

Silver-plated ware for Junior Officers—Eighty-four table knives, 84 dessert knives, 60 dessert forks, 48 table spoons, 60 dessert spoons, 60 teaspoons, 24 salt spoons, 12 mustard spoons, 12 butter knives, 12 gravy ladles, 12 castors without cruetts, 6 water pitchers, 6 sugar bowls, 6 waiter's trays, 6 round vegetable dishes, 8-inch, covered.

WASHINGTON, D. C., Feb. 1.—The Bureau of Supplies and Accounts, Navy Department, is calling for proposals for 240 air port lenses, for shipment to Cavite, all to be of the best quality and manufacture,

glass to be clear and free from specks and bubbles, surface to be smooth and edges neatly ground.

Also on the same date, for shipment to the same place, 100 hydrometers, glass; 240 thermometers, to be mounted on silvered-brass plate.

Will of the Late George B. Barrett, Pittsburg, Pa.

PITTSBURG, Pa., Jan. 30.—The will of the late George B. Barrett, head of the Geo. B. Barrett Co., who died several weeks ago, has been filed for probate and, after making several bequests, he leaves his entire estate, valued at fully \$1,000,000 to his wife, Martha M. Barrett. The will is dated Feb. 16, 1903, and written by Mr. Barrett. By this document he leaves to his daughter, Cora, \$10,000, which amount is not to be deducted from her share in the estate when it is finally divided. He directs that no inquiry or appraisal be made. He names Mrs. Barrett executor. The will is witnessed by William Aul and Wm. G. Stewart.

By a codicil dated July 27, 1905, he increases the amount to be given his daughter to \$20,000, and stipulates that she receive it under the same conditions recited in his will. He also leaves \$5,000 to his brother Thomas, of Marshall, Mo., and \$3,000 to Mary Melvina Dewing, of Oakland, Cal., the amounts to be paid in annual installments of \$1,000 each. He closes the codicil by saying: "In order to avoid troubling my dear wife I appoint the Fidelity Title & Trust Co. to settle and carry out my wishes." The codicil is witnessed by William Aul and W. O. Harrison.

Mr. Barrett held 800 shares of the stock of the Second National Bank, which has a market value of \$240 a share, and his stock of jewelry is worth \$200,000. He held large amounts of real estate, insurance company stocks and also stock in a number of business enterprises. The business of the Geo. B. Barrett Co. will be continued as it has been in the past. Mr. Barrett's affairs are said to have been left in splendid condition. He is said to have held mortgages amounting to about \$40,000. The value of his estate is not given. Some apprehension had existed regarding the future of the business of the house, but the management will be entirely by Mrs. Barrett and the Fidelity Title & Trust Co.

M. M. Huck, Kenosha, Wis., Files Voluntary Petition in Bankruptcy.

MILWAUKEE, Wis., Feb. 4.—Michael M. Huck, Kenosha, Wis., has just filed a voluntary petition in bankruptcy in the office of the clerk of the United States court in Milwaukee. The assets are given approximately as \$10,200 and the liabilities are about \$8,500.

Among the creditors for amounts of \$150 or above, as shown in the schedule of assets and liabilities, are the following, all unsecured claims: S. Glickauf & Co., \$110.75; I. Schwartz, \$178.44; W. A. Rogers, \$298.10; White, Wile & Werner, \$185.10; Louis Kaufman & Co., \$175.85; L. Bauman Jewelry Co., \$301.70; Geneva Optical Co., \$155.90; M. F. Barger & Co., \$155.90; Arnstine Bros. Co. (Cleveland), \$1,896.73; George A. Barrett Co., \$183.92; F. C. Happel Co., \$970.60; Hirsch & Op-

penheimer, \$169.57; H. J. Stoufer, \$129.20; B. Schuette, \$274.71.

Of the assets about \$500 is claimed exempt. The assets include \$8,000 worth of stock on hand in the store, and \$1,510 of accounts receivable. Claude A. Huck claims \$90 for wages due him, a prior claim under the law. The time for a meeting of creditors has not yet been definitely determined.

Involuntary Bankruptcy Petition Filed Against Stephen F. Bell, Atlantic City, N. J.

ATLANTIC CITY, N. J., Jan. 30.—An involuntary petition in bankruptcy has been filed in the United States Court against Stephen F. Bell, jeweler and dealer in art goods and bric-à-brac on the Boardwalk. The usual allegations as to insolvency are made by the creditors who filed the petition, among them L. W. Levy & Co., whose claim was on a note for \$240; Cohn & Rosenberger, who have a merchandise claim for \$225, and Wagenheimer Bros., who are merchandise creditors for \$72. They claim that Bell has transferred a portion of his property to others and converted another part of his assets into currency with which he had paid certain creditors, thereby preferring them over others, all of which acts are contrary to the Bankruptcy Law. An application was made for the appointment of a receiver and John B. Slack, an attorney, was appointed by the court.

Mr. Bell, who was originally employed by Victor Freisinger, started in business for himself in 1903, and in 1906 the business was incorporated as the Bell-Smith Co., with a capital of \$10,000. Later Mr. Bell withdrew from that company and opened a store at 909 Boardwalk, in this city, but evidently did not prosper, despite the fact that he has shown himself industrious and enterprising.

Paris Pearl Market.

PARIS, Jan. 29.—The new year started quietly, but there is nothing unusual in this, as the first half of January is generally given over to stocktaking and business does not begin until the 15th or 20th. The news reports from New York, many of them erroneous, by the way, made a bad impression upon Parisian dealers who have large outstanding accounts in America and to some extent hindered transactions here, as dealers preferred to wait until conditions were adjusted. Despite these facts, however, it is generally believed that as far as the gem trade is concerned the worst is over or nearly over, and that a recovery is at hand. The reaction in the discount rates in France, Germany and England is the first sign of revival in business and is giving an elasticity to the market and an encouragement for speculation.

D. Cohen, 27 rue Laffitte, who suspended in December, owing about \$500,000, has been declared a bankrupt. The assets are not large.

The Letsler-Lorch Co., Louisville, Ky., filed articles of incorporation last week, with a capital of \$10,000. The incorporators are: M. M. Lorch, V. M. Lorch, Harry S. Grab and Joseph C. Marchal.

The Queen Anne

MADE IN A COMPLETE SERVICE



ICE CREAM DISH

A beautiful, chaste effect in the Old English thread border,
at a popular price.

In addition to our complete line of Sterling Wares we are now showing a new line of Deposit Ware in large variety of original styles and designs, for the Spring trade

Woodside Sterling Co.

Silversmiths

192 Broadway

New York



National Monthly Import and Export Statistics.

WASHINGTON, D. C., Feb. 1, 1908.—The records of the Treasury Department contain the following comparative statistics of interest to the jewelry trade, for December, 1906, and for the 12 months ended December, 1907:

	IMPORTS.		—12 Months Ending—	
	Dec., 1906.	Dec., 1907.	Dec., 1906.	Dec., 1907.
Clocks and parts of.....	\$55,644	\$41,332	\$581,877	\$581,613
Watches, materials and movements.....	262,780	229,021	2,761,958	2,921,805
Diamonds, uncut, including miners', glaziers' and engravers' (free).....	1,518,180	85,287	11,778,119	8,740,278
Diamonds, not set (dutiable).....	2,726,523	140,002	25,282,118	18,951,599
Bort.....	19,666	4,754	105,723	181,975
Precious stones, rough or uncut (free).....	16,784	9,448	159,423	152,365
Precious stones and pearls, not set (dutiable)....	1,029,885	143,226	6,919,831	4,755,376
Jewelry and manufactures of gold and silver.....	176,943	1,801,807	790,706
EXPORTS OF FOREIGN MERCHANDISE.				
Clocks and parts.....	\$247	\$70	\$1,580	\$728
Watches, materials and movements.....	2	4,989	2,830
Diamonds, rough, including miners', glaziers', etc.	1,013	2,349
Diamonds, n. e. s. (dutiable).....	20,170	55,313
Precious stones and pearls, not set (dutiable)....	314	7,516	29,937	30,411
Jewelry and manufactures of gold and silver.....	3,049	24,860	6,931
EXPORTS OF DOMESTIC MERCHANDISE.				
Clocks and parts.....	\$121,177	\$132,202	\$1,357,292	\$1,509,457
Watches and parts.....	113,890	100,443	1,626,967	1,588,639
Jewelry and manufactures of gold and silver....	179,962	151,980	1,925,906	1,961,316
Plated ware.....	70,111	66,574	857,755	844,201

Importations at the Port of New York

Weeks Ended Jan. 26, 1907, and Jan. 25, 1908.	1907.	1908.
China, Glass and Earthen Ware:	\$62,157	\$36,375
China.....	16,529	7,336
Earthen ware.....	33,207	14,184
Glass ware.....	3,697	2,432
Instruments:		
Musical.....	19,980	7,130
Optical.....	3,901	3,762
Philosophical.....	5,800	1,261
Jewelry, etc.:		
Jewelry.....	22,410	8,262
Precious stones.....	472,729	73,143
Watches.....	25,600	19,766
Metals, etc.:		
Bronzes.....	2,003	610
Cutlery.....	43,820	26,736
Dutch metal.....	5,140	4,519
Platina.....	28,222
Silverware.....	1,256	89
Miscellaneous:		
Alabaster ornaments....	221
Amber.....	12,485
Beads.....	7,046	2,160
Clocks.....	4,717	1,152
Fans.....	14,885	5,447
Fancy goods.....	10,931	4,697
Ivory, manufactures of..	43,411
Ivory.....	597	3,005
Marble, manufactures of.	7,412	2,703
Statuary.....	4,721	4,091

Programme of the Coming Convention of the Indiana Retail Jewelers' Association.

INDIANAPOLIS, Ind., Feb. 3.—J. A. Oswald, secretary of the Indiana Retail Jewelers' Association, has formally announced that the annual meeting will be held at the Claypool Hotel, in this city, Feb. 18-19. He has made public the following programme:

TUESDAY, FEB. 18, 10 A. M.

Reading of minutes.
Applications for membership.
Annual address of President C. Z. Rowe, Argos. 1:30 P. M.

Reports of officers.
Unfinished business.
Address by Ralph B. Clark, president Indiana Retail Merchants' Association.
Five minute talks by members. 7:30 P. M.

"Salesmanship," A. F. Sheldon, Chicago.
WEDNESDAY, FEB. 19, 9:30 A. M.

"Organization and Its Results," S. R. Miles, president National Retail Hardware Association.
Reports of committees.
New business.
Election of officers.
Installation of officers.
Adjournment.

Man Arrested in New Haven, Conn., Believed to be Wanted for Defrauding Jewelers in Bridgeport.

BRIDGEPORT, Conn., Jan. 31.—Max Wittstein and J. H. Savard, of this place, went to New Haven to-day to identify Louis Ammerman, who was arrested at that place last Tuesday night on a charge of passing worthless checks. Ammerman is believed to be the same man who defrauded several concerns in this city just before Christmas. When arrested he wore an overcoat which it is alleged he purchased with a forged money order for \$60 at Davis & Savard's store here.

Mr. Wittstein sold Ammerman a diamond ring at his jewelry store and Henry C. Reid, another jeweler, sold him a watch. Ammerman presented orders for \$40 and \$50, respectively, at these stores, and succeeded in cashing them without difficulty.

Inspectors Redding, of Boston, and Myers, of New York, of the Postal Department, arrived in New Haven last night to look up Ammerman, believing him identical with a man they had been seeking for weeks, whose money order frauds extended through New England. Chief of Police Cowles, of New Haven, refused to turn over his prisoner to the post office detectives, claiming that Ammerman must first stand trial for passing the alleged forged check.

Jewelers' Gold Bars Withdrawn and Exchanged at New York.

Week Ended Jan. 31, 1908.

The U. S. Assay Office reports:

Gold bars exchanged for gold coin.....	\$196,471.72
Gold bars paid depositors.....	41,530.89
Total.....	\$238,002.61

Of this the gold bars exchanged for gold coin are reported as follows:

Jan. 27.....	\$10,317.60
" 28.....	57,224.89
" 29.....	66,935.50
" 30.....	41,241.68
" 31.....	20,652.05
Total.....	\$196,471.72

Weber Bros., Lancaster, Wis., have dissolved partnership.



J. I. Claiborne is a new jeweler in Lewiston, Idaho.

A new jewelry store will shortly be opened in Christine, N. Dak., by E. O. Huss.

A. C. Mellinger and C. A. Mellinger, St. Louis, Mo., have opened a store in Oakdale, Cal.

M. Fredericks will occupy new offices in the Kamm building, in San Francisco, Cal., in a few days.

C. H. Lovell, formerly of Chicago, has opened a watch and jewelry repair establishment in Alvin, Tex.

E. L. Cook has opened a store at the corner of Golden Gate Ave. and Laguna St., San Francisco, Cal.

David Goodman will open a general store in Sioux City, Ia., some time this month and will handle a line of jewelry.

Joseph Arnheim, formerly with J. Treager, Oakland, Cal., will soon start in business for himself in San Francisco, Cal.

George Williams is a new jeweler in Shreveport, La., where he has started in business on a small scale in the Burnstein building.

J. Pennington, formerly of Providence, R. I., has opened an establishment as a manufacturing jeweler at 9th and Court Sts., Reading Pa.

T. Powell has leased quarters in room 13, in the Todd block, on Birkley Ave., Norfolk, Va., where he will engage in the repairing of clocks and watches.

W. C. Hall, formerly with J. C. Klaholt, Springfield, Ill., has leased quarters at 6th and Murray Sts., at that place, where he has engaged in business on his own account as a watchmaker.

C. E. Henderson and D. W. Geiger have started in business at the Thompson, Brannon Co.'s old location, 52 Patton Ave., Asheville, N. C. Both members of the firm were formerly with the Thompson, Brannon Co.

Market Price for Silver Bars.

The following are the quotations of silver bars in London and New York, as reported by Zimmermann & Forshay:

	London.	New York.
Jan. 28.....	25 1-2d.	\$.57 3/4
" 29.....	25 5-8d.	.57 1/2
" 30.....	35 9-16d.	.57 3/4
" 31.....	25 1-2d.	.57 1/4
Feb. 1.....	25 9-16d.	.57 1/2
" 3.....	25 9-16d.	.57 1/2

Thos. Floden has purchased the store formerly owned by Henry J. Birkstrand, Huxley, Ia.

The jewelry store of E. L. Smither, West Point, Va., was entered one night recently by thieves, who escaped with \$175 worth of stock. Most of the stock was taken from the show window, which had been broken with a brick.

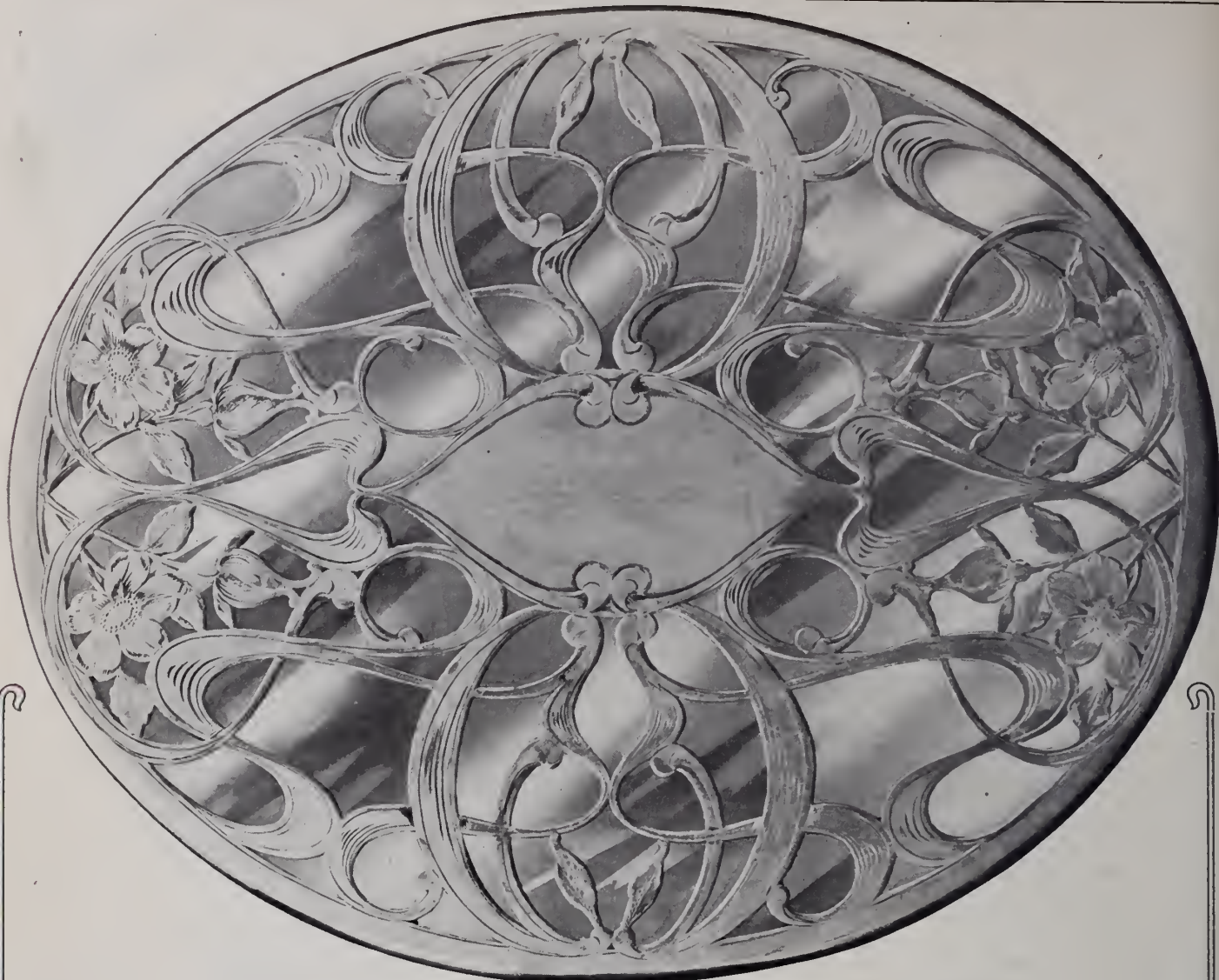

No. 860.—Three-fourths Actual Size. Price, \$20.00, Subject to Usual Discount

WE wish to thank the Trade in general for that active co-operation and support which have given an added impetus to our uninterrupted efforts to produce a line of

DEPOSIT WARE

that is the peer of any similar line on the market to-day. In this we have been eminently successful, and largely attribute our success to the general appreciation and ready recognition of the undisputed superiority of our wares. We still aspire to greater perfection and are consequently always on the alert to improve our facilities and beautify our deposit ware.

¶ The above design shows one of our many and latest achievements. We make these from three and one-half to fourteen inches in diameter; also in tile to match tea sets, etc. We decorate earthenware, fine china, glass, etc., with deposits of silver, in unique and appealing designs.

**Tea Sets, Decanters, Sandwich Plates, Fancy Pitchers, Colognes,
Finger Bowls, Flasks, Pin Holders, etc.**

In fact, Everything in Deposit Ware

Depasse Manufacturing Co., 318-320 East Twenty-third St., and
41 and 43 Maiden Lane, New York

PACIFIC COAST AGENTS: A. I. HALL & SON, Incorporated, 717 Market Street, San Francisco, Cal.
Information regarding our lines furnished on application

Another Cablegram from the Diamond Syndicate Reiterating Their Determination to Maintain the Present Prices of Diamonds.

Eduard Van Dam, the diamond cutter, of 37 Fifth Ave., New York, recently received a letter from one of the largest jewelry houses of the west, stating that many of its customers were afraid to buy diamonds at the present time, believing that prices would be reduced, and asked Mr. Van Dam to procure for the benefit of their customers an official statement in regard to the stability of the diamond market. While Mr. Van Dam knew and had the utmost confidence that prices would be maintained, in order to allay the fears of the western house and their customers, and not knowing that THE CIRCULAR-WEEKLY had already received an official cable message from the Diamond Syndicate, assuring the maintenance of prices, he cabled to the Syndicate and received Monday the following cablegram in reply:

Eduard Van Dam, 437 Fifth Ave.

We repeat official statement sent to JEWELERS' CIRCULAR, New York, that Syndicate will continue their policy of maintaining prices and this is in agreement with De Beers and Premier mines.

**Wernher, Beit & Co.,
for Diamond Syndicate.**

lowing creditors hold notes: Antwerp & New York Diamond Co., \$2,615; Irving Baum, \$400; Arnstein Bros., \$6,924; David Mayer, \$3,682; Albert Lorsch & Co., \$5,125; B. H. Davis & Co., \$1,387; Samuel Hess, \$2,331; Malliet & Maxwell, \$1,572; L. & B. Lehr, \$401; German Exchange Bank, \$7,860.

Mr. Epstein, attorney for the bankrupt, said that the causes of the failure were the usual ones in the Maiden Lane district at this time. Two months ago Mr. Hodes paid off 25 per cent. of his indebtedness in anticipation of a good holiday business, and as a result he was left with little ready money. The dull trade, slow collections and financial depression are given as the direct reason for his trouble.

The business was started in 1895.

A meeting of the creditors of Mr. Hodes was held Monday afternoon at the offices of Epstein Bros., attorneys, at which time an offer of a 25 per cent. settlement was made by the debtor. Matters relative to the bankrupt's financial condition were dis-

examining the rings the other grabbed a tray of fountain pens valued at \$50, which he placed under his coat, and walked out of the store, his companion following him. The trick was discovered and the police notified, with the result that the men were captured in Rutherford and committed to the Hackensack jail.

In connection with the theft of gold from the refinery of Emil Schneider, at 306 South St., George Bernard, 221 Mulberry St., was arraigned in the First Precinct Police Court Saturday morning on a charge of receiving stolen property. He was placed under \$1,500 bail to await the action of the Grand Jury. With him was William Johnson, colored, of 25 Calumet St., a watchman employed at the refinery, who admitted in court that he stole 16 ounces of the precious metal. He also confessed a previous theft. He was held in \$1,000 bail to await trial.

A large number of friends in the trade were present at the funeral of the late Louis T. Wiss, of the firm of J. Wiss & Son, which was held on the afternoon of Jan. 27 from the Wiss home, 83 Johnson Ave. The honorary pallbearers were: Dr. Aaron C. Ward, William H. Jones, C. A. Campbell, F. F. Anness, Woodbridge; E. A. Anness, Brooklyn; Alexander M. Linnett, H. W. Watson, George A. Burnett, Albert H. Peal and C. L. Gairard. The interment was made in Fairmount Cemetery. All the employees of the factory of the firm and the store were at the funeral.

Judge Francis Scott has sentenced John R. Richardson to 10 years in State prison. It will be recalled by readers of THE CIRCULAR-WEEKLY that Richardson, together with George Brown, entered the store of Leon Friedmann, 196 Market St., Paterson, in June, and attempted to carry away a tray of diamond rings. The men were captured after a chase through the principal streets. Brown appeared before Judge Scott at Special Sessions and received a sentence of eight years. While awaiting indictment Richardson succeeded in getting out of jail in July, but was captured in Davenport, Ia. He received three years for jail breaking and seven years on the other charge.

Savannah, Ga.

Frank Werm was recently installed Junior Warden of Magnolia Encampment, Independent Order of Odd Fellows.

A large plate glass window in the store of R. Van Keuren & Co. was recently broken accidentally by a bronze figure which slipped from the pedestal upon which it had been placed near the show window.

Announcement was made at Philadelphia last week of the dissolution of the firm of the Castelberg Jewelry Co., with offices and salesrooms in the Mint Arcade building, that city. Joseph J. Greenberg has withdrawn. All the assets have been assigned to Sylvester C. Klopfer and William P. Klopfer, who have assumed the liabilities of the business and who will continue it under the name of the Castelberg Jewelry Co., Klopfer Bros. The firm does a large instalment jewelry business.

cussed, and a committee of three appointed to investigate the condition of its assets and liabilities.

Newark.

A. W. Hencke, a watchmaker and jeweler, has rented a store in the Morris building. He expects to take possession about May 1.

The Flemington Cut Glass Co., Flemington, N. J., which was recently incorporated with a capital stock of \$25,000, has leased a factory building. The work of installing machinery was begun last week, and it is expected that the plant will be ready for operation within three weeks.

An attempt was made Sunday night of last week to enter the jewelry store of Isaac Wigdor, Broadway near 21st St., Jersey City. The would-be burglars were frightened away by the prompt action of the police. The thieves, of whom there were four, were trying to force open the front door, but on the approach of the policeman they fled down a side street.

Wm. T. Rae & Co., after 53 years in the jewelry business, have retired. The stock of watches, diamonds, jewelry and silverware, etc., will be disposed of at public auction at their store at the corner of Broad and Center Sts., the sales being held daily at 10 A. M. and 2 P. M. until the stock is disposed of. The business was started as a firm in 1860.

Two strangers visited the store of John Macher, East Rutherford, recently, and asked to be shown some finger rings. While one of the fellows pretended to be

This not only confirms the two previous cablegrams already received, but emphasizes the fact that the cablegram to THE CIRCULAR-WEEKLY published last week, was the official statement to the trade of the United States that the Syndicate which controls the output of diamonds for the world will positively maintain the prevailing prices.

Adolph L. Hodes Files a Voluntary Petition in Bankruptcy in New York.

A voluntary petition in bankruptcy was filed last Thursday in the United States District Court at New York by Adolph L. Hodes, a wholesale diamond dealer, 65 Nassau St., New York. His schedules, showing liabilities of \$46,160, and assets of \$32,369, consisting of debts due on open account, \$16,243; money in banks and elsewhere, \$728; machinery, \$300, and stock in trade, \$11,000.

Among the unsecured creditors are T. Quayle & Co., \$784; E. L. Spencer & Co., \$289; Hutchison & Huestis, \$164; Dunn & Rodenburg, \$139; E. A. Bennett & Co., \$380; C. H. Cook Co., \$234; Wightman & Hough Co., \$846; Plainville Stock Co., \$140; Cheever, Tweedy & Co., \$270; T. G. Frothingham & Co., \$350; Bugbee & Niles Co., \$428; Geo. L. Paine Co., \$188; Bates & Bacon, \$635; Frolichstein, England & Klein, \$227; Crane & Theurer, \$327; R. F. Simmons Co., \$1,142; Walter E. Hayward, \$158; A. H. Bliss & Co., \$811; Geo. L. Brown & Co., \$382; Chas. Keller & Co., \$1,410; Untermeyer-Robbins & Co., \$164; D. F. Briggs Co., \$822; Stern Bros., \$921; Standard Button Co., \$291; Doran, Bagnall & Co., \$379; A. O. Kiefer, \$579. The fol-

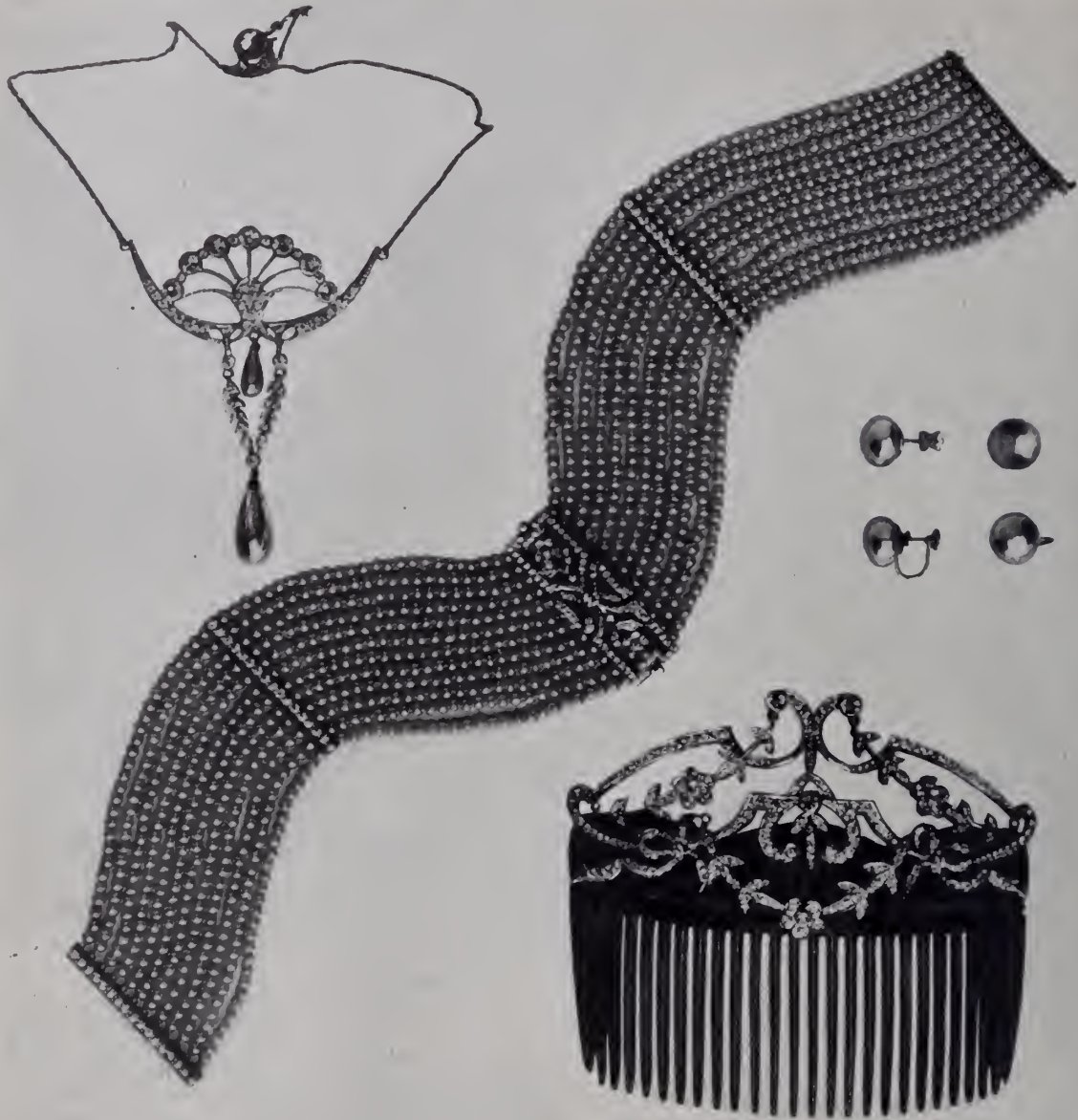

ILLUSTRATIONS of a few of our many creations, comprising the best examples of artistically mounted artificial diamonds and Egyptian pearls in sterling silver with Platinum effect. The high artistic merit and skilful craftsmanship, usually found only in the most expensive diamond pieces, characterize all our productions.

Pearl Collars

Necklaces

Barrettes

Bar Pins

Tiaras

Pendants

Bracelets

Ear Drops

Combs

Brooches

Rings

Scarf Pins

GEORGE H. CAHOONE COMPANY, Makers of Artistic Jewelry

NEW YORK

OFFICE AND FACTORY

CHICAGO

Jewelers' Bldg., 9 Maiden Lane

Manufacturers' Bldg., Providence, R. I.

Heyworth Bldg., 42 East Madison St.



Alfred H. Bullion, San Francisco, Cal., has left on his northern trip.

Sam Kierski, with Fred L. Lczinsky, San Francisco, Cal., has left for the north.

R. Myers, with R. & L. Myers, San Francisco, Cal., returned, last week, from the north.

T. C. Boylan, representing Manning, Bowman & Co. on the Pacific coast, is on his Spring trip through the northwest.

Among the traveling representatives in Los Angeles, Cal., last week, were: Mr. Samuels, Towle Mfg. Co.; and J. H. Lucas, Fishel, Nessler & Co.

Phil. Mendelsohn, with Adolph Eisenberg & Co., San Francisco, Cal., has left for the Oregon territory. J. C. Fcig, of the same company, is on his northwestern trip.

Fred. Sheridan, Pacific coast representative of the Attleboro Mfg. Co., and other lines, has just returned from Denver, Colo., and the northwest, to the San Francisco office.

The following traveling representatives visited Lancaster, Pa., recently: Louis Gerstman, Dattelbaum & Friedman; Joseph D. Varley, Allsopp Bros.; Mr. Hassenplug, Aikin-Lambert Co.; C. G. Cushman, Reed & Barton; C. H. Mountjoy, C. F. Rump & Sons.

All but one of the representatives of A. I. Hall & Son, San Francisco, Cal., are now in the field. Mr. Smith is in the south, Mr. Boss in the north, and Mr. Valentine with the silver line, and Mr. Graham with the 14-karat gold line, are both in their respective territories.

Salesmen in Boston, Mass., last week, included: E. V. Hutton, H. & E. O. Belais; Edwin F. Skinner, Roy Watch Case Co.; William Vonder Schmidt, H. C. Kionka & Co.; Frank J. Ryder, Walter E. Hayward; Henry G. Thresher, Waite Thresher Co.; Mr. Drown, Osthy & Barton Co.

The following traveling representatives were in Savannah, Ga., recently: L. D. Reynolds, Shafer & Douglas; C. S. Down, F. H. Cutler & Co.; A. Eadrick Wood, S. B. Champlin Co.; Ed. Sinnock, Ehrlich & Sinnock; G. H. Sluter, Bippart, Griscom & Osborn; J. T. Griffith, Jr., Carter, Howe & Co.; A. E. J. Winter, Enos Richardson & Co.; David Newser, E. A. Cowan & Co.; Morris Lissauer, Zach. A. Oppenheimer.

Among the traveling representatives who visited San Francisco, Cal., last week, were: Don Childs, B. A. Ballou & Co.; Mr. Wilkins, Osthy & Barton Co.; Mr. Remington, Maintien Bros. & Elliot; Mr. Wilkinson, J. J. Somer & Co.; Mr. Kleckner, Theodore W. Foster & Bro. Co.; Louis Blackinton, W. & S. Blackinton Co.; Harry Hildebrand, H. C. Lindol & Co.; Harry E. Farquharson, E. A. Potter & Co.; F. E. Whiting, Whiting & Davis; Mr. Samuels, Towle Mfg. Co.

Traveling representatives who called on the Cincinnati, O., trade, during the past week, included: P. J. O'Donnahue, Philadelphia Pearl Novelty Co.; Walter S. Strauss, Jacob Strauss & Sons; Charles A. Hetzel, C. A. Hetzel & Son Co.; George A. Allsopp, Jr., Allsopp Bros.; William J. McQuillin, Mount & Woodhull; K. B. Carr; Link & Angell; J. T. Griffith, Jr., Carter, Howe & Co.; Mr. Duncan, C. Ray Randall & Co.; Mr. Tinker, William B. Durgin Co.; Fred Casper, Mauser Mfg. Co.; John F. Garland, Keller Jewelry Mfg. Co.; Eugene C. Holbrook, Ferdinand Bing & Co.'s Successors; George Pitzer, Goodfriend Bros.; Mr. Gorman, Woodside Sterling Co.; R. E. Williams, St. Louis Silver Co.; H. M. Van Bergen, Snow & Westcott.

Traveling representatives calling on the jewelers of Omaha, Nebr., last week, were: Mr. Bennett, Waite, Mathewson Co.; Leopold Heyman, Stern Bros. & Co.; G. W. Cureton, Henry G. Lefort; A. D. Sinnock, Ehrlich & Sinnock; R. D. Kennedy, Mauser Mfg. Co.; Thos. E. Rogers, Riker Bros.; John A. Lassau, Martin, Copeland Co.; J. M. Curtis, International Silver Co.; Hugh E. King, Queen City Silver Co., Fessenden & Co.; Joseph C. Wilson, Wm. A. Rogers, Ltd.; Arthur E. Hall, Holmes & Edwards Silver Co.; George D. Law-

rence, Reed & Barton; J. Mills Dillaway, International Silver Co.; Miller Faller, Whiting Mfg. Co.; Henry Sherrill, Sinnock & Sherrill; G. Fickenaue, Alvin Mfg. Co.; Meyer Lehmann, Ludwig Lehmann.

Among the traveling representatives who called on the trade of St. Louis, Mo., last week, were: R. H. Stevens, Mahie, Todd & Co.; L. Selligsberger, Mauser Mfg. Co.; Mr. Henderson, Crane & Theurer; C. L. Hartshorn, Kremetz & Co.; C. T. Smith, Reed & Barton; C. T. McKenna, Kelly & Steinman, Inc.; James Baker, Frank M. Whiting & Co.; Eugene C. Holbrook, Ferdinand Bing & Co.'s Successors; Charles E. Eckel, Unger Bros.; Max Huss, S. Borgzinner Co.; J. W. McClannin, Wilcox Silver Plate Co.; C. A. Hulstrom, Wilcox & Evertsen; A. L. Hancock, C. Sydney Smith & Co.; H. N. Van Bergen, Snow & Westcott; Charles A. Hietzel, Charles A. Hietzel & Son Co.; George A. Allsopp, Jr., Allsopp Bros.; K. B. Carr, Link & Angell; Lewis P. Cook, S. Sternau & Co.; W. H. Osborne, R. Wallace & Sons Mfg. Co.

The following traveling representatives called on the trade in Kansas City, Mo., during the past week: S. C. Powell, S. C. Powell & Co.; Henry W. Sherrill, Sinnock & Sherrill; C. A. Barnum, International Silver Co.; E. L. Mumford, Miller, Fuller & Whiting Co.; Robert L. Clark, Towle Mfg. Co.; T. W. Agnew, New Haven Clock Co.; F. R. Truell, W. H. Saart Co.; W. D. Powers, Wm. C. Greene Co.; F. L. Pettee, Waterbury Clock Co.; Theodore Kuehl, Geo. Kuehl & Co.; E. A. Moore, Sykes & Strandberg; W. D. Sinnock, Ehrlich & Son; F. E. Hyatt, Philadelphia Watch Case Co.; E. P. Ledos, Ledos Mfg. Co.; W. R. Cobb, Cobb & Co.; E. J. Hiller, Sussfeld, Lorsch & Co.; R. W. Stevens, Bay State Optical Co.; Mike Lampert, Henry Zimmern & Co.; "Billie" Lamb, Geo. Fuller & Sons Co.; Ben. S. Cohen, Michigan Optical Co.

Among the traveling salesmen who, last week, visited the trade at Pittsburg, Pa., were the following: Frank E. Behrendt, Homan Mfg. Co.; M. Decker, Plainville Stock Co.; Frank W. Culom, Sulzberger Bros.; H. A. Scofield, Scofield, Melcher & Scofield; George Pilzer, Goodfriend Bros.; H. N. Van Bergen, Snow & Westcott; Eugene C. Holbrook, Ferdinand Bing & Co.'s Successors; J. P. Ford, Ford & Carpenter; Walter R. Bristol, Wm. Rogers Mfg. Co.; J. T. Griffith, Jr., Carter, Howe & Co.; Frank L. Wood, Ludwig Nissen & Co.; L. N. Jacobs, Peckham Seamless Ring Mfg. Co.; R. H. Schley, Sloan & Co.; E. J. Walther, D. F. Briggs Co.; Charles E. Eckel, Unger Bros.; Maurice Kohn, Silhermann, Kohn & Wallenstein; Chas. S. Peckham, J. H. Peckham & Co.; George W. Whittemore, Sessions Clock Co.; Charles L. Sexton, Wm. L. Sexton & Co.; S. Stern, Stern Bros. & Co.; Mr. Rogers, Rogers & Co.; Charles Jacot, Friedrich Speidel; W. J. Parker, Osmun-Parker Mfg. Co.; H. B. Bliss, Gorham Co.

Cleveland.

The Lewis Jewelry Co., of this city, has been incorporated, with a capital of \$30,000, by F. B. Lewis, C. C. Lewis, R. P. Dorman, W. D. Alexander and W. K. Stanley. F. B. Lewis had previously been doing business for some time under the style of the corporation at 530 Euclid Ave.

A. S. Jacoby, a bankrupt jeweler of Elyria, was under examination before the referee in that town last week and, according to the report received here, he testified that his failure was in part due to the fact that he had lost money on gambling. It appears that the stock, which was believed to be worth \$3,200, is not worth much more than \$1,500.

Using a brick as a missile to smash the window, burglars early last week broke into the jewelry store of Joseph Diener, 824 Prospect Ave., S. E., and stole watches and other articles valued at over \$1,000. The men were seen standing inside the store, but no attention was paid to them until they started to run away, whereupon several people gave chase, but the thieves escaped. Mr. Diener has filed a petition in bankruptcy, with liabilities of \$10,368 and assets of \$6,058.

Mrs. Miles Rosenthal, wife of the former jeweler of Youngstown, who is now bankrupt, has asked the United States District Court of this place for homestead exemption rights, demanding \$500 in lieu of a homestead, for \$35 worth of furniture "in lieu of a cow," for \$15 worth of furniture in lieu of "six sheep and the wool shorn from them"; for \$15 worth of furniture "in lieu of two swine." Also for the saving of wearing apparel, beds, a cook stove and stove pipe, for fuel sufficient to last 60 days, for a Bible, hymnbooks, pictures, provisions of the value of \$50, a sewing machine, a knitting machine, for cabinets of natural history. Her application, made Jan. 28, was one of the first of its kind made for a long time, though the right is an old one.

St. Louis.

G. N. Moore, Marion, Ill., accompanied by Mrs. Moore, visited members of the local trade, last week.

Irwin Schoenle, of the Maschmeyer-Richards Silver Co., will go out on his regular Spring trip, this week.

Smith Tompkins, Canton, Ky., who was arrested, Jan. 9, on a charge of having obtained a diamond ring by means of a worthless check for \$250 from the John Bolland Jewelry Co., and who recently pleaded guilty to the charge, has been sentenced to a year in the workhouse.

Thomas Humphrey, Louisville, Ky., was married here, last week, to Miss Ethelyn Winn Loring, daughter of the late James Loring and an heiress to a considerable fortune. Miss Loring was one of several heirs to an estate of about \$150,000. The bride was one of the faculty of a St. Louis high school. She is a woman of broad culture and some literary attainments. Mr. and Mrs. Humphrey departed for Louisville, last Friday.

Joseph Gilbert, proprietor of a jewelry store at 1625 Market St., who was accidentally shot in his store on the night of Jan. 10, by Jacob Good, a pawnbroker at 820 Market St., died, last week, after he had been discharged from the city hospital, whither he was taken after the shooting. It was expected that he would recover, but complications set in after he left the hospital. Good surrendered to the authorities immediately upon hearing of the death of his friend, but he was released by the coroner's jury the following day, the jury finding that the shooting was wholly accidental and without malicious intent. Mr. Gilbert, on the day he was shot, had opened up a new store and Mr. Good had called upon him to inspect it. Seeing a revolver on the counter he picked it up to examine it, when Gilbert warned him. Hardly had he uttered the words when the weapon was discharged and the bullet tore through Gilbert's breast and lodged in his back. Mr. Gilbert completely exonerated Mr. Good before his death.

John J. Kluge, Greenfield, Ia., has sold his stock to the Wilson Drug Co. Mr. Kluge will remain in the store looking after the jewelry stock for the new firm for a time and will also settle up his own business, prior to leaving for Germany, where he will remain about a year.



Anglo-American.



Royal Militaire.



Royal Cloth.



Royal Militaire.



Royal Hair.



Tudor.



Washington.



Royal Hair.



Siren.



Royal Velvet.



Royal Hat.



Neptune.



Atlas.



Royal Scrub.



Royal Mirror.

S. E. HOWARD'S SON & Co.

15 WEST 24th STREET, NEW YORK CITY

Opposite 5th Avenue Hotel

MANUFACTURERS OF

High Grade Hair Brushes and Artistic Merchandise for the TOILET TABLE



Apollo.



Godiva.



Neptune Dress.



Royal Lace.



Royal Nail.



Magazine Cutter.



Shoe Horn.



Letter Opener.



Button Hook.



File.



Eraser.



Corn Knife.



Cuticle Knife.



Bonnet.



Buffer.



Manicure Set.



Jewel Tray.

"HOWARD'S QUALITY" TURTLE EBONY

North Attleboro.

John Killiam has resigned as foreman of the H. F. Barrows Co.

Charles Peckham is home from the west. Charles H. Clark is also back.

Edwin Coddling has been chosen treasurer of the North Attleboro Gaslight Co.

Donald LeStage has returned from a western trip in the interests of the H. D. Merritt Co.

Percy J. Callowhill Co., hub cutters and die sinkers, have removed from the Bliss building on Chestnut St. to Attleboro.

William Armstrong has been added to the traveling force of the Paye & Baker Mfg. Co. His headquarters will be at Chicago.

William F. Maintien has given two beautiful silver loving cups as prizes for the scholars in the Plainville schools to compete for in a prize speaking contest.

Employees of A. H. Bliss & Co. had a long hunt last week after a \$50 diamond ring. An employe tossed it to another to be polished and it struck a wind pipe, bounding away. The jewel was finally recovered.

Joseph L. Sweet, of the R. F. Simmons Co.; George K. Webster, Fred A. Howard, Walter B. Ballou, of R. Blackinton & Co., and William H. Riley, of Riley & French, are greatly interested in the formation of a new bank in North Attleboro. Plans for the new institution will materialize upon Mr. Webster's return from a trip in search of health. He expects to be back in North Attleboro the latter part of the week.

The full extent of the losses of the Jewelers' National Bank was forcibly impressed on the stockholders on Saturday morning when W. B. Ridgeley, Comptroller of Currency, ordered an assessment of \$100,000 upon the owners of stock. The assessment should be paid by Feb. 24, but the receiver has been granted permission to allow the shareholders to pay 25 per cent. at this time and the balance in monthly payments. The whole amount must, however, be paid by May 24. This assessment is equivalent to 100 per cent. of the holdings.

Syracuse.

The Syracuse High School Commission is advertising for sealed proposals for the installation of a system of electric clocks for the Northside High School building. Bids should be deposited with the clerk of the commission at his office, 622 Onondaga County Savings Bank building, prior to Feb. 10, at 2.30 p. m. Proposals must be accompanied by cash or certified check to the amount of five per cent. of the bid, as an evidence of good faith.

Word, received here last week, to the effect that Oscar E. Ward, of Phoenix, N. Y., had passed away, caused distinct sorrow and regret to his friends in the trade, as Mr. Ward was an old and well-known jeweler. The deceased, who was about 55 years old and has been in business since 1879, died Jan. 21 of pneumonia after a short illness following the death of his son, who had died two days previously of the same trouble. Mr. Ward was postmaster of

Phoenix for many years and was highly respected.

Alexander H. Towar, who died Jan. 23 at Lyons, N. Y., after a short illness, was associated with Olando F. Thomas in the silver plating business from 1892 until the Manhattan Silver Plate Co. was merged with the International Silver Co., and was superintendent of the Lyons branch of the latter company until it was closed up. Mr. Towar was born Aug. 14, 1836, and on account of his age retired from active business about five years ago. He was a veteran of the Civil War, having served in the engineering corps.

Boston.

C. G. Aldrich has been in Maine on a business trip during the past week.

George H. Pike, of the suburb of Brookline, has purchased adjoining property and will enlarge his place of business.

C. G. Baxter, of Grimshaw & Baxter, the largest material house in London, Eng., has been in Boston calling on the trade.

T. Zurbrugg and C. M. Fogg, of the Keystone Watch Case Co., and Irving Smith, of the Crescent Watch Case Co., were in Boston during the week, visiting the trade.

Edgar S. Marston, a silver finisher, residing in Melrose, Mass., is a petitioner in bankruptcy, his application having been filed in the United States Court here Jan. 28. He has liabilities of \$859 and assets of \$10.

John C. Nelson, formerly inside salesman, will hereafter cover the greater Boston district for Charles May & Son, the other New England territory being retained by William T. Crowley, traveler for the firm.

Col. S. O. Bigney, Attleboro, who is a candidate for delegate-at-large to the national Republican convention, was the guest a few evenings ago of the Republican party leaders at Chelsea, Mass., speaking at a reception given in his honor.

Mrs. M. Satz, Ware, Mass., whose liabilities are estimated at \$2,400, and assets at \$500, is offering to compromise with Boston and other creditors at 20 cents on the dollar. Some of the larger creditors have asserted to the settlement.

E. A. Cowan has retired from traveling and will, for the present year, at least, be at the home office instead of on the road. His route south and west will be taken by David Nemser, who has been inside salesman for a number of years. Messrs. Nemser, W. F. Macomber and R. J. Taylor started on their spring trips last week.

Leroy D. Braman, the Attleboro, Mass., jeweler, who was reported as missing some weeks ago, has been made a defendant in a petition in bankruptcy in the United States Court in this city, filed by C. A. Marsh & Co., a creditor for \$1,071.64; Bates & Bacon, \$1,719.36, and the D. F. Briggs Co., \$2,330.50. Further details as to Mr. Braman's affairs appear on another column.

William H. Brobst, Lynnvilleville, Pa., is erecting a new store building, 45 by 60 feet, at that place.

Washington, D. C.

President Roosevelt has appointed Prof. Leverett Mears, of Williams College, a member of the Assay Commission to determine the weight and fineness of the gold and silver coinage of the United States for the last year. The commission will meet at the Mint in Philadelphia, Pa., Feb. 12.

Harris & Schafer, Pennsylvania, were recently the victims of the robbery of a brooch, valued at \$40, which was afterward recovered in a local pawnshop, where the young woman who had stolen it was endeavoring to pawn it. The circumstances in connection with the case were unusual, and it is believed that the young woman, who is an art student, had become discouraged in the results of her work and took this means of recuperating her resources. While the judge in the local police court here pronounced a sentence of \$50 or six months in jail, he announced that sentence would be suspended if the young woman would immediately leave the city, which friends assisted her to do.

A fraud order has been issued by the Postmaster-General against the Rogers Mfg. Co. and the Rogers Silverware Co. and their officers and agents, acting as such. The concerns were located at 44 N. 4th St., Philadelphia, Pa., and at Reading, Pa., and the fraud order was issued because their managers are engaged in getting out a scheme or device for obtaining money through the mails by means of fraudulent representations and promises in violation of the Act of Congress of Sept. 19, 1890. On Jan. 3 of the present year the Rogers Mfg. Co. was cited to show cause why a fraud order should not be issued against it and Jan. 9 was fixed as the day for the hearing. At the request of the company the hearing was continued until Jan. 17, at which time George M. Rogers, of Philadelphia, proprietor of the business conducted under the names of the Rogers Mfg. Co. and the Rogers Silverware Co., appeared. After the issuance of the first citation to the Rogers Mfg. Co., the circulars sent out by Mr. Rogers under the name of the Rogers Silverware Co. were called to the attention of the Department, and as the two schemes were identical, Mr. Rogers was advised that the hearing would cover both matters, which it did. The fraud order resulted.

Canada Notes.

W. K. McNaught, M. P. P., manager of the American Watch Case Co., Toronto, Ont., is at Atlantic City, N. J.

W. K. George, of the Standard Silver Co., Toronto, Ont., leaves Feb. 12 on a trip to the Mediterranean with his wife.

For some time past letters containing money addressed to several jewelry firms of Toronto, Ont., have disappeared in the postoffice. Suspicion of stealing them fell upon James E. Harris, employed in sweeping and cleaning up the postoffice, who had access to all parts of the building. Three decoy letters addressed to "Ryrie & Co.," one of the firms which had previously missed money letters, were placed in the office on the night of Jan. 28, and Harris was watched and detected with the letters in his possession. He admitted his guilt.

Wedding Gifts.

(Sterling Silver)



No. 529

Cheese Tray \$2.25
and Server 1.50



No. 128

Lemon Dish \$2.00
and Fork .75

Merrill Brothers Company Silversmiths

22 Green Street, NEWARK, N. J.



No. 543

Olive Dish \$2 00
and Tongs 1 50

A more attractive assort-
ment of new goods than
ever before.

Illustrations half size.



No. 510

Tea Strainer \$2 75
and Holder 2.00

AARON COEN, Pres.

H. J. SEILER, Vice-Pres.

RALPH WAKEFIELD, Treas.

WAKEFIELD & SEILER CO., Inc.

Makers of Fine Jewelry

109 OLIVER STREET

NEWARK, N. J.

THE CHEAPEST HOUSE IN
THE COUNTRY FOR SEAMLESS
BRACELETS AND SEAMLESS
BALL NECK CHAINS



IN PRICE AND FINISH
OUR GOODS ARE BEYOND
REPROACH. WRITE US
AND BE INFORMED

A NEW HOUSE WITH NEW IDEAS

New Creations in Scarf Pins with Jade, Coral, Amazonite, etc. Gold Mounted Combs in all shapes and prices in real and imitation Tortoise Shell. Lockets that are different [from the staple goods now on the market. We make a specialty of supplying the MANUFACTURING TRADE WITH JOINT WIRE BRACELET TUBING.

10K. GOODS WITH AN 18K. FINISH

Philadelphia.

Ernest S. Goldy, engraver, removed last week from 11 N. 13th St. to 805 Sansom St.

E. Lahacci, watchmaker, has accepted a position with Alexander Kay, 928 Chestnut St.

C. Wicker, watchmaker, has resigned his position with E. H. Herbein, 1622 Market St., to go with a Market St. department store.

C. A. Beitel, watchmaker for the trade, 710 Chestnut St., has accepted a position as watchmaker with George Ware, Atlantic City.

Charles Zakrywski, watchmaker for William Gibbons, 40th and Market Sts., has resigned his position to go with A. F. J. Dorn, Camden, N. J.

Thomas Judg. of the traveling staff of J. B. Beitel & Co., started out last week on his initial trip for the firm and will cover Central Pennsylvania, Delaware and Maryland.

C. Schaeffer, formerly watchmaker for C. M. Evans, Reading, Pa., is in Philadelphia, and may determine to locate here permanently or start in the repair business in Reading.

Julius Hardegg, watchmaker, with R. L. Saunders, 8th and Market Sts., has been transferred to the branch store on Germantown Ave., which was some months ago opened by Mr. Saunders.

M. K. Laudenslager, Souderton, Pa., who has recently leased a new store, larger and more attractive than the old one, was in this city last week buying fixtures for the place and other furniture to embellish it.

Col. J. Warner Hutchins, president of the Philadelphia Jewelers' Club, was a guest last week at the dinner of the Beeksteak Club of the Columbia Club (a club within a club), with a reputation for unique feasts.

Ed. Sickles, of M. Sickles & Sons, is receiving the congratulations of his friends on the fact that his daughter, Ruth, is convalescent after an operation for appendicitis, and is so far recovered that she will be removed to her home this week.

Harry Gerry, formerly of New York, but who has been conducting a retail store on Baltimore Ave., West Philadelphia, sold out his stock and fixtures last week and departs this week for Los Angeles with his family for the benefit of his health.

William Penfold, eastern representative of the Dueber-Hampden Watch Works, with headquarters at 818 Chestnut St., is moving his office fixtures, equipment, stock, etc., to New York city, where he has obtained quarters and where the agency will be permanently located hereafter.

The Turner, Lawfler & McGinness Clock Co., 2826 W. Dauphin St., has sold out its stock, good will and fixtures to the H. G. Bates Clock Co., 17th and Columbia Ave. E. W. Lawfler, of the old company, has gone to Nazareth, Pa., to re-engage in business with his father, Steward Lawfler, jeweler of that town.

That Frank Allee, Dover's most prominent jeweler, has sought and been denied a position under the government as audi-

tor in the Treasury Department at \$4,000 a year is interesting news in the trade of this city. Former Senator Allee is believed to be now more interested in politics than in the jewelry business.

The Keystone Watch Case Co. has decided to issue 10,000 additional shares of stock at par, which is \$100 a share. The authorized capitalization is \$8,500,000. Of this \$5,000,000 is outstanding. T. Zurbrugg, president of the company, with Charles Fogg, made a business trip to Boston last week and returned at the week's end.

For the first time since he was seriously injured in an elevator accident in a New York department store, George Angel, the New York representative of the George L. Paine Co., visited this city last week and was given a cordial welcome by a host of old friends in the trade. Mr. Angel is still compelled to use crutches, but otherwise is hearty and well.

Many local jewelers learned with sincere regret last week of the recent death of Amos B. Ewing, for many years a prominent retailer of Smithville, N. J. Mr. Ewing was a frequent visitor to this city, where he did most of his buying and had a wide acquaintance. He was a good story teller, affable and popular. The cause of death was kidney disease.

Neelan L. Butterwick, aged 74 years, a retired jeweler and watchmaker of Freeport, Pa., who is visiting a son at 3414 N. Judson St., was the victim of an atrocious assault last week at 23d and Ontario Sts. Two negro highwaymen attacked him and after knocking him senseless, robbed him of a gold watch and chain, another watch, and some money. The highwaymen escaped.

James Goodman, individually and as a member of the late firm of Sperling & Goodman, which conducted, for about a year, a retail store on 8th St., near Vine St., was adjudged a voluntary bankrupt in the United States District Court last week. The financial troubles of Sperling & Goodman were recently recounted in THE CIRCULAR-WEEKLY. David W. Amram has been appointed referee.

Among the out-of-town retailers buying stock in this city during the week were the following: Karl Weidel, Trenton, N. J.; A. E. Baylies, Bristol; D. H. Krause, North Wales; L. L. Bickings, Norristown; Willis Porter, Burlington, N. J.; M. E. Hunter, Beverly, N. J.; Henry Bolte, Atlantic City; Wm. Huber, Elmer, N. J.; Milton Reed, Doylestown; and John MacPherson, Mauch Chunk, Pa.

During the violent wind storm which visited this city Saturday night a huge electric sign was torn from its fastenings on a Sansom St. building and hurled against the bulk window of the diamond establishment of Col. J. Warner Hutchins, 728 Sansom St., smashing the glass and damaging a show case. The store was closed and police guarded the place until temporary repairs were made and the diamonds and jewelry protected from thieves.

Gabe A. Gorfine, 52 N. 11th St., owes the recovery of \$20, representing the value of a diamond emblem stolen from him recently, to the alertness and wit of his young son. A man, pretending to make

a purchase, escaped from the store with the emblem, but the lad had scrutinized him before he departed. Several days later the boy accidentally came face to face with the man on Market St. A policeman was called and the man arrested. Afterward he offered settlement, which was accepted, and the larceny charge was dropped.

The annual meeting of the Philadelphia Jewelers' Club will be held Tuesday evening of next week, when officers, nominated at the meeting of the board of governors last month, will be elected. There are no contests of any consequence and the club will remain during 1908 under practically the same management as last year. Col. J. Warner Hutchins is the unanimous nominee for president, and all the other officers are unopposed. At this meeting final arrangement will be completed for the annual banquet to be held on Washington's birthday anniversary at the Bellevue-Stratford Hotel. The dinner promises to be on the same high plane as in previous years and to be made notable by the attendance, as after-dinner speakers, of men noted as statesmen, not only in sections from which they come, but in national affairs. It is believed that some of the presidential candidates will be guests of honor.

Lancaster, Pa.

TRADE CONDITIONS.

The stagnation in the great tobacco trade of Lancaster, Pa., has had its effect upon the jewelry trade, but just as soon as last year's packings of tobacco begin moving, and the new crop, still in the growers' hands, also begins moving, there will be the inevitable rebound in all channels of trade here, and the jewelers will come into their own again.

S. Kurtz Zook has returned from New York.

Harry T. Kiehl, head salesman for Louis Weber & Son, has returned from a rest taken at Ephrata, Pa.

Howard W. Detterline and Charles E. Foose, of the Non-Retailing Co., are back again from trips over their respective territories.

Francis Zwally, a former Lancaster watchmaker, and later a jeweler of Milwaukee, Wis., died there, Jan. 27, and was buried here Friday.

J. P. Kabler, Luray, Va., who has discovered a new process of welding and hardening copper, visited Lancaster last week, en route to Schenectady, N. Y.

John C. Perry, superintendent of the Hamilton Watch Co.'s factory, who is taking a long vacation for his health at New Salem, Mass., has been visiting Lancaster.

E. G. Hoover, Harrisburg, and Archie K. May, York, Pa., jewelers, visited Lancaster last week, while John J. Bowman, of Ezra F. Bowman's Sons, last week visited Harrisburg and Middletown, Pa.

The police authorities last Friday expelled from the city a couple of cheap jewelry peddlers, a city ordinance forbidding itinerant dealers in any sort of merchandise from selling their wares, though it does not prohibit the taking of orders. The ordinance was enacted as a protection to the local merchants.

Illustration $\frac{1}{4}$ Actual Size.

PEARL STRINGS BUCKLES GARNET JEWELRY NECK CHAINS

M. GUGENHEIM

Importer of

Brooches, Festoon Chains, Combs, Hat Pins, Collars, Jet Goods, Mesh Bags,
in German Silver, Gilt Metal and Sterling

NEW YORK OFFICE:
33 Union Square, Decker Building

PARIS
32 Faubourg Poissoniere

Q We have maintained and are still maintaining our reputation for making the most salable and finest line in the market of fine rolled gold

HAT PINS

SCARF PINS

TIE CLIPS

BROOCHES

LINK BUTTONS

COMBS

BRACELETS

VEIL PINS

BUCKLES

FOBS

FESTOON NECKS

BARRETTES

CAMEOS

Anticipating the enormous demand for Stone, Shell and Coral Cameos, we prepared for it by originating a variety of these beautiful carvings, that is far in advance of any other line, quality, beauty, workmanship and price compared; set in the finest rolled gold plated mountings. Wearing and selling qualities guaranteed.

MAINTIEN BROTHERS & ELLIOT, NORTH ATTLEBORO
MASSACHUSETTS

NEW YORK OFFICE, 9, 11 and 13 Maiden Lane

Providence.

Charles Briggs and one of his daughters sailed for Europe last week. They will join other members of the family who are at present touring the continent.

William H. Luther, of the firm of William H. Luther & Son, was re-elected chairman of the Board of Police Commissioners, Saturday. Mr. Luther has made an enviable record as chairman of the board, a position which he has held for the past five years.

The partnership existing between George F. Greene, William S. Greene and Randolph A. Greene, who have been doing business under the name of George F. Greene & Co., has been dissolved. George F. Greene will continue the business under the firm name, and has assumed all the responsibilities of the old firm.

Joshua Lothrop, a retired manufacturing jeweler and salesman, died at his home in Pawtucket last week. He was a native of Pawtucket, and was at one time a member of the firm of W. A. Beattie & Co., manufacturing jewelers in the Dyer Land Co.'s building, in this city. Later the firm was known as Lothrop & Livsey.

The Gorham Co. will reopen on full time a week from next Monday, after a two weeks' lay off. The shops are closed in order that an account of stock may be taken, although the designers are being kept at work. The company has recently drawn a design for a huge \$4,000 loving cup, which one of the Chicago railroads is to offer as a golf trophy next Summer.

Charles A. Stahl, the oldest precious stone setter in the country, died at his home in this city on Tuesday. He was buried Friday afternoon. He was born 85 years ago in Wurtemberg, Germany, and came to this country when he was 20 years old. He was employed as a stone setter in the shops of Jeremiah D. Fowler, in this city, for the past 33 years, and worked until he was physically unfit for labor.

Charged with attempting to blackmail Henry A. Kirby, a prominent manufacturing jeweler of this city, William W. Sayles, 24 years old, was taken into custody last week by Inspectors J. J. O'Malley, James Ahern and C. R. Egan, of police headquarters. Sayles is said to have admitted his guilt to the police, but when arraigned before Judge C. M. Lee at a special session of the Sixth District Court pleaded not guilty. He was ordered to furnish \$1,000 surety for appearance to the Sixth District Court for a hearing yesterday.

The automobile show and military carnival, which was opened Saturday evening and which will be held every afternoon and evening this week in the big new armory on Cranston St., has been opened largely through the efforts of well-known jewelers. They are Gen. H. S. Tanner, who has a jewelry store on Westminster St., and Capt. R. S. Hamilton, of Hamilton & Hamilton, and Maj. Horace Manchester, of the Manchester Jewelry Co. Capt. Hamilton is adjutant of the First Regiment of Infantry, and Maj. Manchester is inspector-general on Gen. Tanner's staff.

Baker & Windsor's refinery at 189 Eddy St., was visited by a stubborn fire Friday evening. The blaze broke out around the

forge and burned through the flooring, working its way to the engine room. In order to get at the heart of the fire the firemen had to chop considerable of the woodwork in partitions and the floor. The refinery is located in the big Fitzgerald building, and the blaze was discovered by Edward J. Costello, the night watchman. The alarm was sent in at 9.45 o'clock, and it was not until after midnight that the recall was sounded. During the two hours that they were working in the building the firemen devoted their attention to the fire itself thus preventing its spread to the large number of other jewelry shops in the structure.

The Silversmiths' Mutual Aid Society held its 43d annual meeting in Gorham Casino recently, President Arthur W. Barrus presiding. The reports of the secretary and treasurer showed that the sum of \$6,161.52 had been paid in benefits during the year, and while no cash dividends would be paid, the amount of \$692.85 in the treasurer's hands is deemed sufficient to meet the expenses during the vacation. The entire board of officers was re-elected as follows: President, Arthur W. Barrus; vice-president, Charles W. Gower; secretary, Fred. A. Burt; treasurer, Walter A. Clissold; auditors, George W. Rhodes and Arthur G. Jerome; physician and surgeon, John C. Parker. The society was organized in October, 1865, for the mutual relief of its members.

The Mutual Benefit Relief Association of the S. & B. Lederer shops held a ball in Music Hall, Thursday evening. The hall was well filled by members of the association and their friends. A collation was served at 10 o'clock, and later dancing was resumed. The Committee of Arrangements comprised: John S. Eagan, chairman; S. Glaser, secretary; Arthur Kelley, treasurer; Charles Loughery, floor director; William Ernstberger and Charles Legacy, assistant floor directors. Aids: Willard Davis, Harry Weston, George Boiker, J. J. Sullivan. Reception Committee: Walter Lederer, Annie Doherty, B. W. Dodge, May Clarkin, Mary Coleman, L. M. Grant, Emma E. Salisbury. The officers of the association are: President, Leon Grant; vice-president, Walter Lederer; secretary, Sanford Hawkins; treasurer, Nicholas F. Arendt.

The biggest social event that the jewelers in this section have, the annual banquet of the New England Manufacturing Jewelers and Silversmiths' Association, will occur on the evening of Feb. 15, in Infantry Hall, this city. Arrangements to make the affair the most successful ever held are already well under way. Last year Masonic Hall, one of the largest auditoriums in the city, was packed, and in order to provide room for all comers this year's committee has secured the largest hall in the city. The principal speaker will be Joseph C. S. Blackburn, the Governor of the Canal Zone and formerly Senator from Kentucky. He will speak on matters relative to affairs in the Panama Canal regions. The other speakers will be Gen. John S. Wise, of New York, and Dr. Willard Scott, the clergyman from Worcester, who convulsed last year's big attendance. The Executive Committee in charge of the affair is made up of Frank B.

Reynolds, chairman; George H. Holmes and Everett T. Rogers.

Attleboro.

The team from the factory of W. E. Richards & Co. last week won the season's tournament among the factory bowling teams.

Miss Lucy Somerville Sweeney, daughter of Edward A. Sweeney, was married, Wednesday evening, to Marston Woodbury, of Brookline.

Ralph Regnell, son of Herman T. Regnell, of Regnell, Bigney & Co., has gone west, giving up all interest in the jewelry industry to take up mining.

J. Weinstein, Richmond, Va., and Mr. Meyman, of the Crown Mfg. Co., Denver, Colo., were among the buyers who visited the Attleboro factories the past week.

Joseph Heywood, for years with Bliss Bros., and one of the pioneer skilled jewelry workers of the town, celebrated, last week, the 44th anniversary of his wedding.

Col. Sidney O. Bigney, of S. O. Bigney & Co., has made a unique offer to the Knights of Pythias of the town, of which he is a prominent member, standing ready to provide uniforms for all up to a certain large number who join within a limited time.

Attleboro will be largely represented Feb. 15 at the annual banquet of the New England Manufacturing Jewelers and Silversmiths' Association in Providence. Several concerns in this town have become affiliated with the association during the past year, so the contingent from here will be larger than usual.

The Chas. M. Robbins Co. has under consideration the possible erection of a factory on Benefit St., not far from the plant of the Horton-Angell Co. The detailed plans are not yet ripe for announcement. Mr. Robbins is touring Mexico, and it is unofficially stated that no definite steps will be taken in his absence. The concern has grown rapidly in recent years, and the quarters hired in the Makepeace building are none too large.

President Arthur B. Cummings, of the Cummings & King Co., annoyed by discovering that rumors were in circulation regarding his concern, felt obliged, last week, to issue a public statement to relieve the minds of the townspeople and the families of his employes. He found that the laying off of the greater part of his help, an annual custom made advisable by the nature of his business, had led to rumors of financial difficulty. He emphatically repudiates these, and asserts the concern is in excellent condition, and will shortly resume full activity.

Walter F. Eldredge, a jobbing jeweler, formerly located here, was served with papers in a civil process last week, as he stood on the railroad station platform preparing to leave the town. Eldredge was some time ago in business in New York, and was burned out. McRae & Keeler, manufacturers here, brought suit against him, and the New York court rendered judgment, which the Attleboro concern claims it was never able to collect. Learning that Mr. Eldredge had returned to the town for a few hours on business, the matter was hastily intrusted to a civil officer. Mr. Eldredge promptly adjusted the claim.



**Buckles
Clasps
Belt Pins**

Artistic, But Inexpensive

PRODUCTS OF

The "Apollo Studios"

WILL INCREASE YOUR
SPRING SALES

Bernard Rice's Sons

544 BROADWAY

Works and Studios 4-6 Marion St. 205-207 Lafayette St. NEW YORK



No. 471—ELECTROLIER

(Patent applied for)

Copper Bound, Leaded Glass Shade

The "Bryant" Rings.

WE have made the **Bryant Rings** for 50 years, and know how to make first class goods. The stone setting—which every retailer knows is a very important part of the work—we give special attention to. The **Bryant Rings** will help your reputation as a first class Jeweler.



TRADE-MARK

M. B. BRYANT & Co.,

No. 7 MAIDEN LANE,
NEW YORK.

4
Cardinal Points
of
TAVANNES
WATCHES

1. Adjustment to heat and cold.
2. Special nickel-steel balance hair-spring, making the watch proof against all electrical influences.
3. Interchangeable material coming in finished form and ready to use.
4. A broad guarantee covering its time-keeping qualities under all conditions.

TAVANNES WATCH CO.

2 and 4 Maiden Lane, NEW YORK

131 Wabash Ave., CHICAGO, ILL.

"CHECO" BRAND COMBS

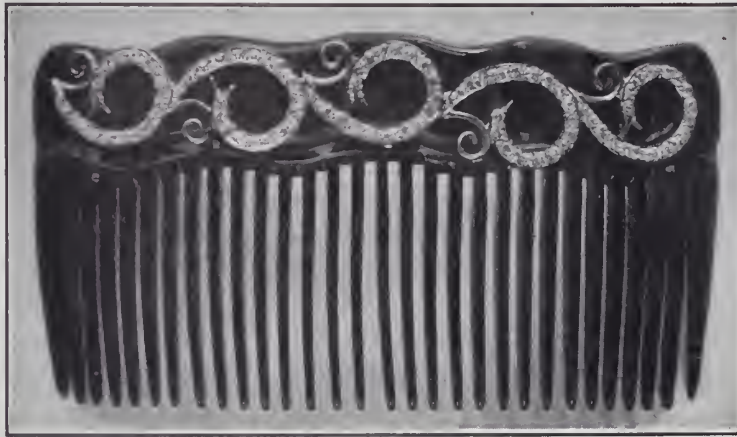

"CHECO" Brand Combs in good selling assortments, will be sent on approval by prepaid express. Examine these combs and return any that are unsatisfactory by express at our expense. Our assortment packages proved of great benefit to the trade last season by keeping their stocks up to the times on new goods. We will be able to give you even better service this season. Why not try one of these assortments NOW?

The Lady Ethel Adjustable Bracelet

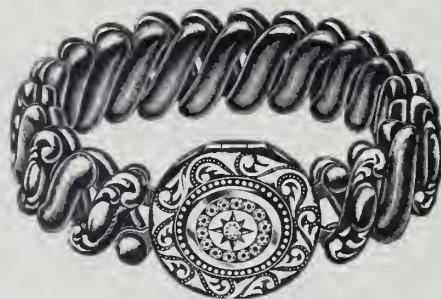
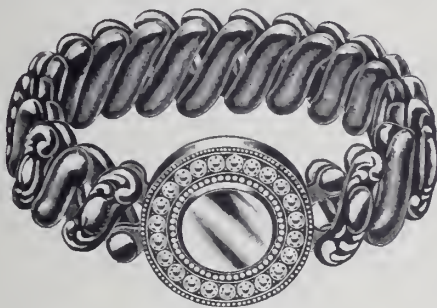

Is still in great demand. If you have none in stock write us to send you a selection package of the latest designs.

We also call your attention to our line of genuine and imitation cameos. This line contains Stick Pins, Lace Pins, Hat Pins, Combs, Etc. We will send you samples of any of this class of goods that you may wish to see. You need a good line of Cameo Jewelry right now. Have you got it? If not just write us to send you samples. If our representative has never called on you drop us a line and we will instruct him to do so.

C. H. Eden Company, Attleboro, Mass.

NEW YORK OFFICE: 550 Broadway

Address all Communications to Attleboro, Mass.

The ADVANTAGE of BUYING
UR RINGS

SPECIAL FACILITIES
in the manufacture of
UR RINGS enable you to
buy them through your
JOBBER as advantageously
as such goods can be obtained
direct from manufacturers

The Untermeyer=Robbins Co.

Seventy-One Nassau Street, New York

Send for the Latest Styles in

MONOGRAMS AND INITIALS

as manufactured by

THOMAS J. DUNN CO.

101 Chambers St., New York

Makers of exclusive styles in

MONOGRAM FOBS

in Gold, Sterling and Rolled Gold Plate.
Our 1908 Ladies' Belt Buckles are most
original and artistic.

Specialties in the Monogram and Initial line.

Send for Illustrated Sheets.



Gems and Precious Stones

Cloth, Postpaid, \$1.00 Published by
The Jewelers' Circular Publishing Co.,
11 John Street, New York.

Pittsburg.

Sol Cerf, of Sol Cerf & Co., spent last week in New York on business, having gone there to buy Spring stock.

E. W. Hill, of Goddard, Hill & Co., has been made a member of the citizens committee of Bellevue, which is opposing annexation of that borough with the Greater Pittsburg.

Joseph Feinagle, a former employe of Henry Dotzenroth, a manufacturing jeweler in the Wabash building, who absconded several months ago, taking with him diamonds of his employer valued at several hundred dollars, was arrested last week at Alliance, O. Feinagle's arrest was brought about by the local police, who sent a description of the man all over the country; he had been working in a restaurant. Feinagle, it is said, pawned the diamond rings which he took from his employer with several North Side pawnbrokers.

L. W. Vilsack & Co. decided not to lease their present storeroom for another term of years and the splendid quarters which the firm has occupied for three years were last week leased to the Wabash Railroad Co. Vilsack & Co. had been paying an annual rental of \$6,000 and the Farmers National Bank, which owns the building, demanded \$15,000 a year rent on a renewal of the lease. Mr. Vilsack refused to pay it, and is now looking for another location, as he does not intend to retire. Mr. Vilsack, with his wife and family, are at present spending a few weeks at Cambridge Springs, where Mr. Vilsack has gone to rest and strengthen his health.

An answer has been filed to the suit of H. E. Hillman, of Wheeling, who has begun proceedings at Washington, Pa., to secure possession of diamonds valued at \$2,100 held by the Real Estate Trust Co. of Washington, executor of the estate of C. E. Gilmore. The trust company in its answer recites that the diamonds were originally given by Hillman to Bessie Burton, who was later charged with larceny by bailee and tried and acquitted. She then gave the gems to Gilmore, who had paid her attorney fees, amounting to \$750. Later she tried to slip away from Gilmore with the rings, but he had her arrested and she is now serving a year in the penitentiary on the charge. Gilmore died a few weeks ago. The trust company denies Hillman's right to the gems.

The stock of W. C. Schmidt, a bankrupt jeweler of New Castle, Pa., was sold Wednesday to George Parker, a New Castle pawnbroker, for \$3,785, which was more than the stock had been appraised at. Some local creditors had authorized that bids for the stock be made up to \$2,000, it having been appraised at \$3,719.70, and much surprise was expressed when it was learned that it brought more than the appraised value. Parker, the buyer, who was one of the appraisers, it is said, wanted the stock because of the excellent location of the store. It is now stated that he will conduct an auction and dispose of most of the goods and then put in a new stock. Schmidt's liabilities were about \$8,000. He has a number of outstanding book accounts, and it is believed that the creditors will realize between 40 and 50 per cent. M. M.

Brewster made claim to some goods which had been bought by Schmidt on memorandum and these were returned to him.

B. E. Arons has been appointed quartermaster of the Veteran Corps 18th Regt. Duquesne Grays, which gave a banquet last Thursday night at the Monongahela House.

The following out of town merchants were in Pittsburg last week: H. H. Weylman, Kittanning; E. H. Kennardell, Tarentum; Frank Worrell, Canonsburg; William Fisher, Greensburg; C. A. Loughman, Braddock; F. E. Leitzell, Scottdale; R. V. Marshall, Freeport; H. C. Morrison, Mt. Pleasant; R. H. Wolf, Smithton; E. F. Priesc, Homestead; T. H. McNary, Washington.

An attempt was made to rob Samuel Lipard's jewelry store at 507 Wylie Ave. several nights ago, but the robbers were unable to gain entrance and were frightened away. Detectives were given descriptions of the men seen around the store. Charles Decker, who said that he is 35 years old and lives at the Yoder Hotel, was sent to Central police station as a suspicious person, as he answered the description given the detectives.

Utica.

C. H. West, jeweler, at Amsterdam, who went into voluntary bankruptcy in December, and later settled with his creditors, was re-engaged in business in East Main St., Amsterdam, as C. H. West & Bro. He will secure a new stock.

The first meeting of the creditors of Charles F. Budd, an Auburn jeweler, was held before Referee Brainerd, at Auburn, on Saturday. Budd was not examined. T. M. Fisher was appointed trustee and the hearing adjourned until Feb. 13. An appraisal of the stock has been started.

Charles B. Mason, of this city, has been appointed by Judge Ray as the receiver in bankruptcy of George C. Smith, Watertown. Mr. Mason has filed a bond for \$12,000, and he will take charge of Smith's property until the appointment of a trustee, which will take place before Referee Atwell, 16 Washington St., Watertown, Feb. 10, when the first meeting of creditors will be held. Mr. Mason was appointed receiver upon the application of Hammel, Riglander & Co., New York, who alleged that replevin suits had been started against Smith, and that there was a danger of a dissipation of the bankrupt's assets before a trustee was appointed.

In spite of widely circulated statements that the famous Cullinan diamond, presented to King Edward, has been removed to Amsterdam, that it was safely transmitted there as an unregistered package, and that two detectives and a private individual ostentatiously carried a dummy parcel to deceive the public, inquiry by the London papers at New Scotland Yard develops that the jewel is still in the charge of the officers of the Criminal Investigation Department at the Yard. It has not been moved from the sealed safe in which it was placed when it was taken back from Sandringham, after being inspected by the King and Queen, and a special staff of officers watch it day and night.—*New York Tribune.*

NORMA
TRADE MARK



One of Our Many New Designs in Spring Samples
J. R./520.

MAKERS

PATENTEES

THE F. H. SADLER COMPANY

New York City Office:
180 Broadway, Room 43.

ATTLEBORO, MASS.

Jos. Mayer & Bros.

Manufacturers of

*STERLING SILVER SOUVENIR SPOONS AND
TABLE WARE, SEAMLESS SWEDGED (NOT
CAST) TIFFANY RINGS, SEAMLESS
SWEDGED PLAIN RINGS*

The largest and most complete line of high grade Fraternal Order Eagle, B. P. O. Elk, Masonic and other society jewelry.

Write for our 1907 Catalogue, if you have not already received one

Jos. Mayer & Bros.

Designers and Makers of the Washington's Silver Service

Seattle, Wash., U. S. A.

Connecticut.

The Ideal Silver Plate Co., Middletown, has filed a certificate of dissolution.

The Landers, Frary & Clark Co., New Britain, is now operating its factory on an eight-hour per day schedule.

Mrs. Julia W. Kirk, widow of the late W. Kirk, for many years a well-known jeweler of Winsted, died recently at her home, at that place, of heart failure.

The work was commenced, last week, of installing an electrical equipment in the factory of the E. Ingraham Co., Bristol, to take the place of the old-fashioned belt system.

Gen. George H. Ford, New Haven, accompanied by his wife, is spending several days in Washington, D. C. While in Washington the couple were introduced to the President, by Senator Brandegee.

Charles D. Davis, of the Davis & Hawley Co., Bridgeport, has been appointed a member of the local Board of Trade's special committee to take steps for the improvement of Bridgeport houses.

Edward H. Cole, for 30 years treasurer of the Eaton, Cole & Burnham Co., Bridgeport, with his headquarters in the New York office of the concern, died at his home in Brooklyn, Jan. 27. Death was caused by kidney trouble.

According to the recent list of assessments in Wallingford, Frank A. Wallace is the largest individual taxpayer in that town, paying an assessment of \$25,000; the Biggins, Rodgers Co. pays on \$85,000; the Hall, Elton Co., on \$21,520; G. M. Allenbeck, on \$25,175; Factory "L," International Silver Co., on \$144,148; Factory "M," International Silver Co., on \$45,980; Factory "P," International Silver Co., on \$38,000; R. Wallace & Sons Mfg. Co., on \$249,355; S. L. & G. H. Rogers, on \$17,500.

The Silver City Plate Co.'s factory on Veteran St., Meriden, which was closed, about a week ago, on attachment filed in a suit brought to recover a chattel mortgage by H. B. Beech, will be reopened and conducted under the direction of President D. H. Ray and Treasurer Sheldon B. Beech, who have been appointed receivers by the Superior Court. A hearing pending the confirmation of the appointment of the temporary receivers and the appointment of two appraisers will take place Feb. 8, at 9:30 A. M., in the Superior Court.

The retail jewelry store of H. J. Dunlap, Maple St., Naugatuck, was entered by burglars, one night recently and gold and silver articles valued at about \$300 were stolen. Entrance was gained by breaking a window pane in the rear of the store and pushing back the latch which locked the window. The burglary is believed to have been the work of amateurs. The stolen property includes the following: One dozen solid silver teaspoons, two silver sugar shells, one silver lettuce fork, one butter knife, carving knife and fork, one carving knife, two-piece game carving set, two pairs pearl opera glasses, silver cigarette case, one cameo ring, one five-stone opal ring, one initial ring, one-half dozen gold filled bracelets, three dozen rolled plate charms, string of graduated amber beads, gold and gold filled crosses and a number of other articles, a list of which



Candle Shades

made of
Silk, Linen, Paper,
Glass, Metal
for
Candelabra or
Single Sticks

Electric Light Shades

made of
Silk, Paper,
Glass Beads
for
Chandeliers,
Electroliers,
Portables, etc.

THE HOHENSTEIN COMPANY

Makers and Importers

Candle and Electric Light Shades

Write for New Catalog 1908

28-30 Waverly Place, NEW YORK

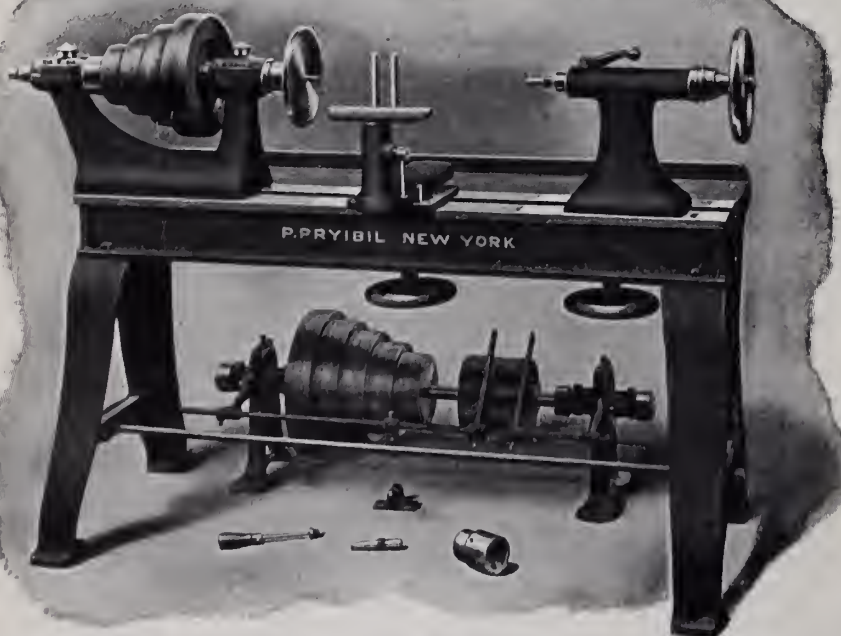

Above Cut Shows Our

METAL SPINNING LATHE

Write for
Catalogue

We manufacture these lathes in sizes from 12-inch to 44-inch Swing,
and can equip sizes 18-inch and larger with our Chucks for oval work.

P. PRYIBIL, 512-524 W. 41st St., New York.

has been given to the police. Mr. Dunlap is a members of the Jewelers' Security Alliance, which offers a reward of \$100 for the arrest and conviction of the thieves.

Association Notes.

The Arkansas Jewelers' Association will meet in annual session in Little Rock, Ark., Feb. 11 and 12, in the Hotel Marion. There are 44 members of the association, and about 50 people are expected in the city to attend the meeting. A number of well-known manufacturing firms will have exhibits at the meeting. Among others are Crescent Silver Plate Co., New England Watch Co., Buffalo Ring Co., W. & S. Backinton Co., the Elgin National Watch Co., Rockford Silver Plate Co. The latter company will have machinery at the convention for the purpose of illustrating how silver is worked. The public will be invited to attend and see the exhibits. E. A. Short, Prescott, is the president.

Retail jewelers of Dayton, O., effected a permanent organization last week at the Phillips house. The objects of the organization are to better trade conditions, and to give the members a chance to get into closer social relations with one another. These officers were elected: President, Edwin Best; vice-president, Webb Eby; secretary, J. W. Anderton; treasurer, Alfred Moser. The executive committee consists of Walter Bowers, Frank Meyer, C. F. Gray, and the committee on by-laws of Messrs. Anderton, Sapp and Bowers.

That the next annual convention of the Wisconsin Jewelers' Association, to be held in Milwaukee, Wis., July 7 and 8 of this year, will be the largest in the history of State jewelers' organizations in this country, and the most novel in several ways, is the promise held out by the board of directors, who met in Milwaukee recently to decide on the date and features of the gathering. An appeal to the wives of members of the association will be sent out shortly, with the hope that this method will bring the men as well as the women to the convention in larger numbers than ever before. Secretary Franklin Thomson is preparing a circular letter which will be sent to the better halves of every member. This letter will contain an urgent invitation to the wives to attend the gathering, and will give a sort of a foretaste of the entertainment to be provided for the feminine guests. This is to be the first time in the history of the State association that a feature of attendance of the gentler sex will be made. Among those who attended the meeting of the directors are: President, Gustav Keller, Appleton; Vice-President George Durner, Milwaukee; Treasurer Henry Stecher, Milwaukee; Secretary Franklin Thomson, Milwaukee; W. H. Becker, Beaver Dam; and C. T. L. Delaporte, Berlin.

The M. J. Max Co., which represents manufacturers in Oregon, has moved its headquarters to 419 Worcester building, Portland, Ore., where the concern not only has more room for the display of the lines carried, but can now offer facilities to customers and friends who desire to make this office their headquarters while in Portland.

Announcement

Messrs. Stern & Corn beg to announce to the trade that they have entered into a co-partnership to conduct a

General Jobbing Business.

The firm will carry a complete line of **Watches, Diamonds and Jewelry; importing Swiss Watches and Diamonds direct.**

Several special lines will be handled exclusively. Any orders intrusted to them will receive the most careful and prompt attention.

STERN & CORN

71-73 Nassau Street, NEW YORK



SHUROLDA



Automatic Scarf Pin Protector



14 Kt. Gold Plate

Price 50 Cents

To Release Pull the Ball

Pat. Mar. 12, 1907. No. 847,164.

The Stronger the Pull the Firmer It Holds

Samples and Prices on Application

Pat. Mar. 12, 1907. No. 847,164.

FOR SALE BY JOBBERS OR DIRECT BY

STERN & CORN, 71-73 Nassau St., NEW YORK



GNTERPRISING and successful jewelers everywhere are pushing the sale of some individual line of watches which they believe to be superior to all others, and upon which they can also make a satisfactory and justifiable profit.

This explains the growing demand for **ILLINOIS WATCHES**, in 0, 12, 16 and 18 sizes, by increasing numbers of leading jewelers throughout the United States.

If you are not familiar with the superior quality of—and advantages gained by handling—Illinois Watches, it will mean reputation and dollars for you to investigate.

Every one fully guaranteed.

Price List sent on application.

ILLINOIS WATCH COMPANY
SPRINGFIELD

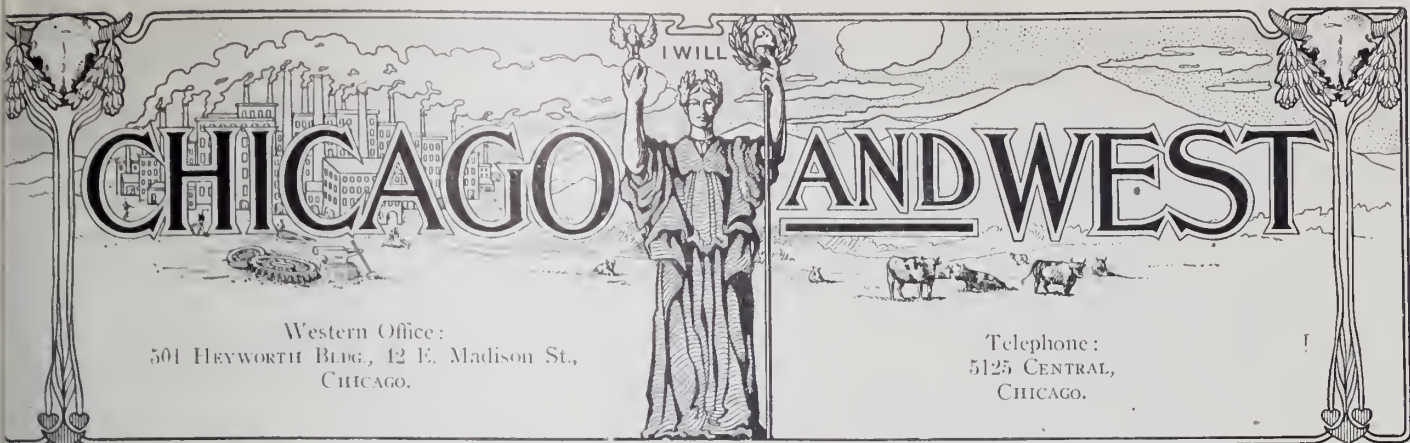

Western Office:
501 HEYWORTH BLDG., 12 E. Madison St.,
CHICAGO.

Telephone:
5125 CENTRAL,
CHICAGO.

VOL. LVI.

CHICAGO, WEDNESDAY, FEBRUARY 5, 1908.

No. 1.

Chicago Notes.

Dudley Bard has been ill with the grippe. Leon Gross has returned from a southern trip.

Alfred Judson is on a trip through Illinois.

O. A. Starke, of the Star Watch Case Co., was a visitor here last week.

F. M. Sproehle, accompanied by his wife and daughter, left for California last week.

G. A. Le Roy, of the Western Clock Mfg. Co., spent a few days here last week.

E. A. Kelly, of L. H. Schafer & Co., has added Michigan to his old territory, Illinois and Iowa.

A jeweler named Marks has opened a small store at the corner of North Ave. and Western Ave.

Mr. Letcher has succeeded Mr. Seligman as buyer for the jewelry department of John M. Smyth.

C. T. Spence has removed from room 204 Columbus Memorial building, to room 601, of the same building.

K. L. Taylor, representing Riley & French, stopped over here last week on his way back from the Pacific coast.

In addition to buying jewelry for Mandel Bros., Max Hertz, the new jewelry buyer, will also buy for the stationery department.

The Chicago office of the American Swiss Watch Co. has removed from room 204 Columbus building, to room 501 Heyworth building.

"Sam" Amberg, formerly with L. H. Schafer & Co., is now representing C. D. Lyon & Co., with headquarters in room 806, Heyworth building.

Gus Weinfeld, H. G. Schramm, J. P. Ryan, Ed Fry and M. W. Silverberg, with the Stein-Ellbogen Co., all left for their respective territories last week.

E. B. Voynow has secured the gold swivel, bar, clasp and spring ring line of Arthur Marson, Newark, N. J., and will represent that firm in Chicago and the west.

M. L. Jalonack, jewelry auctioneer, has returned from a successful sale in Galveston, Texas, and is now engaged in making a sale for H. L. Morrison, Pittsburg, Kan.

The engagement is announced of George H. Spies, of Spies Bros., to Miss Carolyn Hunt, daughter of Dr. and Mrs. Geo. H. Hunt. The wedding will take place in June.

The Powers building fortunately escaped damage by fire last week, although one of the most disastrous conflagrations in years,

consumed many buildings adjoining it on the north side.

One of the first salesmen to return from the Pacific coast was Bert Noble, with Sturtevant & Whiting. Mrs. Noble came out here to meet him and returned with him to the east.

C. E. Child, with the C. M. Robbins Co., has returned from a trip to Florida. Mr. Child has added the cities of New York, Philadelphia, Baltimore and Washington to his present territory.

Hipp. Didisheim, of Hipp, Didisheim & Bro., New York, paid a visit last week to W. G. Grimes, Chicago manager for that firm. This was Mr. Didisheim's first visit to Chicago in six years.

Fred McIntyre, of the McIntyre-Shortess Co., McAlester, Okla., will remain here for some time on business pertaining to the establishment of a new watch factory, of which he is a leading spirit.

R. W. Morris, Chicago manager for the R. Wallace & Sons Mfg. Co., has returned from a trip to Wallingford, where he went to attend the funeral of a daughter of H. L. Wallace, secretary of the company.

The Chicago office of THE JEWELERS' CIRCULAR-WEEKLY and the OPTICAL REVIEW has removed from room 204 Columbus Memorial building, to room 501 Heyworth building. The new telephone number is Central 5125.

Albert L. Kahn, son of Louis Kahn, of L. & M. Kahn & Co., was introduced to the trade here last week by Norbert Gunzburger, the western representative of this house. This is Mr. Kahn's first visit to Chicago and he was much pleased with his reception.

The Walker-Edmund Co. has removed from the second floor of the Columbus Memorial building to the seventh floor of the Republic building, State and Adams Sts. In the new quarters the concern occupies room 724 to 732 and has double the space they formerly enjoyed.

George P. Marchall, of the diamond department of E. V. Roddin & Co., with whom he has been employed for the past 20 years, severs his connection with that firm this week to assume a position in the mail order department of the Mermod, Jaccard & King Jewelry Co., St. Louis, Mo.

Chas. A. Garlick, representing Chas. F. Wood & Co., gave up his office in the Columbus Memorial building last week and went to New York, from which city he will

travel in the future representing the gold jewelry house of Reeves & Browne, an addition to the diamond line of Chas. F. Wood & Co.

Mack A. Hurlbut, the president, and Ira M. Raqabaugh, secretary of the American National Retail Jewelers' Association, stopped over here last week on their way home from a meeting of the executive committee of the association held at Cincinnati, Tuesday and Wednesday of last week, at the Hotel Sinton.

Henry Berkowsky has secured a judgment of \$760 against E. S. Berkley, a retail jeweler who recently sustained a loss by fire at 268 S. Clark St. The judgment is in the nature of a friendly one in order to compel the insurance companies to make a satisfactory settlement. The policies have been attached to secure the judgment.

James Lansing Shourds, only son of Clayton B. Shourds, of the Shourds, Adcock-Teufel Co., died last week, aged 34 years, of typhoid pneumonia, after an illness of one week. Deceased was a bachelor and lived with his parents at 108 E. 45th St. He was a man of fine character and his death comes as a great shock to all who knew him.

John Eulenberg, jewelry jobber in the Heyworth building, is seeking to compromise with his creditors at 25 cents on the dollar, 15 cents to be paid in cash and the balance in six months. He owes about \$10,000 and estimates his assets at about \$4,000. Mr. Eulenberg has had a great deal of sickness in his family lately and has been put to large expense in connection therewith.

The salesmen and heads of departments of Benj. Allen & Co. were the guests of the firm in the annex last week at the annual smoker given by this big jobbing house. The affair was an informal one; there were plenty of good things to eat, and many informal addresses were made. This annual smoker has proved of much benefit to all concerned and serves to bring the salesmen and heads of departments in close touch with one another.

Ruth Newhouse, daughter of Max Newhouse, died last week of typhoid fever, aged 13 years and 10 months, and was buried on Sunday at Rosehill cemetery. Unfortunately Max Newhouse, who represents several eastern lines, was on a trip to the Pacific coast at the time, but a telegram reached him in time for him to return to Chicago to attend the funeral. His friends

ESTABLISHED 1870

SWARTCHILD & COMPANY

CHICAGO, ILL.

"BLACK SHIELD" MAINSPRINGS

Are manufactured for us only by the oldest and most reputable maker in Switzerland.

"BLACK SHIELD" MAINSPRINGS

Are guaranteed in every respect. No better can be had at any price.

"BLACK SHIELD"



MAINSPRINGS

The Product of the Highest Attainment in Mainspring Making

FOR ALL WATCHES

Per Dozen - - - - \$1.25 Per Gross - - - - \$13.50 Per Gross, with Cabinet - \$15.00

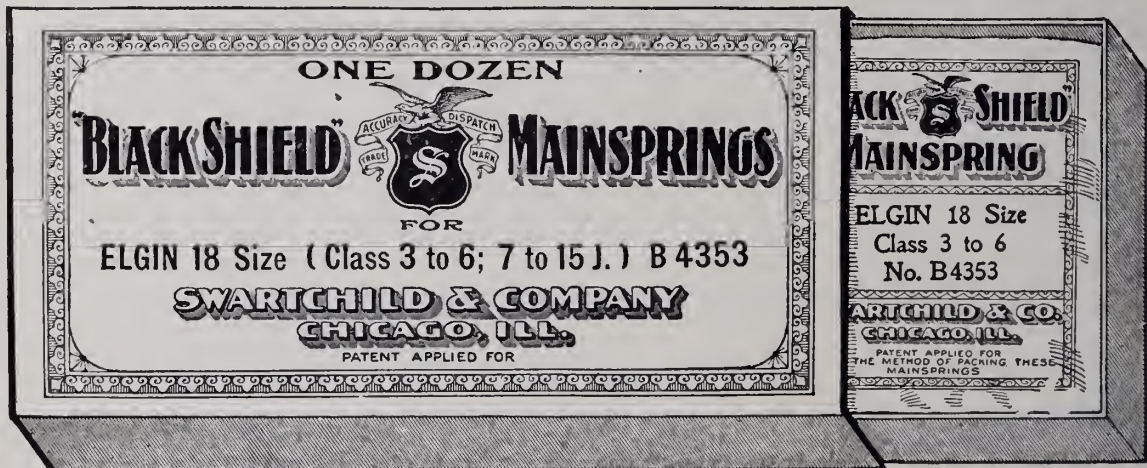

Fac-Simile of Box Containing One Dozen "Black Shield" Mainsprings.



INDIVIDUAL ENVELOPE
Containing one "BLACK SHIELD" Mainspring



MAINSPRING CABINET

Holds forty-eight dozen mainsprings. Made of solid oak, highly polished; has four drawers, each drawer is divided into 12 compartments. Size of cabinet 16 3/4 in. wide, 17 3/4 in. high, 8 in. deep. Compartments in drawers, 6 3/8 in. long, 1 in. wide, 3 1/4 in. high. No. 4319. Price without Mainsprings, \$5.00.

FEATURES

- "BLACK SHIELD" Mainsprings are packed in the following manner: Each spring is wrapped separately in oiled paper and placed in an individual envelope, printed with the name and size for which it is intended.
- Twelve envelopes or one dozen Mainsprings are contained in a well made, strong box properly labeled.
- Useless handling of the springs is avoided, thereby preventing rust or mixing of stock.
- The name "BLACK SHIELD" is scratched on every spring.

SWARTCHILD & COMPANY, 42 Madison Street, CHICAGO, ILL.

in the trade extend their deepest sympathy to Mr. Newhouse in his bereavement.

Among the buyers in town last week were Chas. Geisheit, Niles, Mich.; Nelson Tall, of Tall Bros., Smith Haven, Mich.; Chas. Maurer, Champaign, Ill.; T. L. Combs, Omaha, Neb.; Mr. Dunham, of Dunham & Schick, Holdredge, Neb.; C. A. Smith, Farmington, Ill.; W. H. Mellor, Michigan City, Ind.; D. Benyas, Negaunee, Mich.; Geo. Newton, Van Wert, O.

A despatch from Peoria, Ill., recently stated that the will of the late Mrs. Lydia Bradley was filed for probate, disposing of her estate, valued at \$3,000,000. By the terms of the will the entire property goes to the support of the Bradley Polytechnic Institute which she established. The property at its present valuation will yield the institute \$60,000 a year. Mrs. Bradley bequeathed a total of \$5,000 to 50 or 60 heirs, children of her brothers and sisters, who will institute suit to annul the will, charging undue influence was exerted to induce Mrs. Bradley practically to cut them off. In the will proper Mrs. Bradley left \$50,000 to these heirs, but in a codicil reduced the sum to \$5,000.

Pacific Coast Notes.

The wife of A. E. Howard, Merced, Cal., died last week. Mr. Howard has sold his residence in that city.

G. Reber, Petaluma, Cal., is selling out his stock, and will retire from business.

H. C. Thompson, Long Beach, Cal., sustained severe injuries recently by falling from his bicycle.

J. J. McEvoy, who has been traveling for a San Francisco house, has bought the business of F. F. Nobles, Kennett, Cal.

The bankrupt stock of A. W. Susen, El Paso, Tex., has been turned over to E. R. Tyler, Chicago, and is being closed out.

The American Jewelry Co., Oak'and, Cal., suffered considerable damage by water, used to extinguish a fire in an adjoining store, last week.

A. Protsch, Redondo, Cal., has gone into partnership with W. B. Woolsey and will open a branch at Sawtelle, Cal., where Mr. Woolsey will have charge.

The California Gem Mining Co., San Bernardino, Cal., held a meeting of stockholders, Jan. 28, for the purpose of electing directors for the ensuing year.

Ernest Mueller, Eureka, Cal., has received a settlement at 25 cents on the dollar on a claim which he entered against the railroad company, five years ago.

The stock issued by the company interested in diamond prospects in the vicinity of Oroville, Cal., for the purpose of developing the property, has been fully subscribed, and the work will proceed immediately.

John Meyers, recently arrested in Sacramento, Cal., has confessed that he robbed the store of Wm. H. Warren, of that city, of a tray of gold rings, Jan. 2. Meyers admits that he had a confederate in the robbery.

Maurice Stern, Eureka, Cal., has been absent for the last two weeks, and it is said that stock worth \$600 has disappeared from his store. Suits have been brought against him by J. S. Lehrberger & Co., San Francisco, and an attachment has recently been issued.

Cincinnati.

Mr. Kettle, of the Waltham Watch Co., was a visitor here the past week.

J. Sollinger and family are visiting the former's mother in Avondale, O., for a fortnight.

Mr. Dickinson, manager of the Elgin National Watch Co., called on the trade here in the past week.

The stock of Harry Arenburg, which was appraised at \$2,400, was sold at auction Jan. 22 and brought \$1,800.

I. W. Lederer, of the S. & B. Lederer Co., and his wife, are in Avondale, visiting friends for a few days.

D. J. Gutmann, of L. Gutmann & Sons, sailed Jan. 30 for a three months' trip in foreign lands, including Japan.

Mrs. Ann Evans, mother of Ivor J. Evans, Covington, Ky., died Jan. 26, at the age of 88 years, after a lingering illness.

William Buchreitz, formerly with Richter & Phillips, has embarked in the jewelry and watchmaking business for himself.

E. Richter, of Richter & Phillips, is attending to business again, having sufficiently recovered from a severe operation on his neck.

Kinsler & Co., Covington, Ky., are having an auction sale with the intention of closing out their business in Covington, Ky. L. C. Eisenschmidt, who is largely interested in this company, will confine himself exclusively to the Newport store.

Joseph Spiegel, formerly connected with the E. & J. Swigart Co., died suddenly at his home on Elm St., Jan. 23. He is survived by a widow and two daughters to whom the sympathy of the trade is extended.

The local jobbers and manufacturers held their regular meeting Thursday evening, Jan. 30, at the Sinton Hotel, for the purpose of laying out plans for future work. There will be another meeting in two weeks, when a more definite report of proceedings will be given.

The stockholders of the Herschede Hall Clock Co. held an annual election Jan. 13, when the officers of last year were re-elected with the addition of Walter Herschede as treasurer and director of the company. John A. Herschede had previously acted as both secretary and treasurer.

Out-of-town jewelers who were here the past week purchasing stock included: I. N. Pollock, Ashland, Ky.; Carl B. Durbin, Peru, Ind.; R. J. Timmerman and wife, Batesville, Ind.; John F. Hornberger, Laurenceburg, Ind.; H. W. Mills, Washington Court House, O.; Charles O. Oberholtzer, Centerburg, O.; Walter G. Watts, Barnesville, O., and U. E. Sapp, Dayton, O.

The local Retailer Jewelers' Association held its annual election Friday evening, Jan. 31, and the following officers were chosen. President, John Bertling; vice-president, William Fink; second vice-president, L. Dornseifer; secretary, Edward F. Kaclin; treasurer, George Nagel. A special meeting is called for Feb. 11, when preparations will be begun for the national convention to be held here next August.

Charles Cook, Jr., of Charles Cook, Jr., & Bro., opticians, at 42 W. 6th St., died Monday, Jan. 27, at his home on Dexter Ave., Walnut Hills, at the age of 42 years.

Mr. Cook was born in Cincinnati, and when a young man just out of school began his business career with his father, who was then in the jewelry business at 5th and Smith Sts. In 1889 he opened an optical business, which has continued up to the present time. Mr. Cook had the distinction of being the first graduated optician to open business here. He devoted his entire time to business, and was very successful. Deceased had not been in good health for some time, having never recovered fully from an attack of pneumonia a few years ago. He was an active member of the C. O. F. The business will continue as heretofore under the old firm name.

D. I. Byers, late of the Cincinnati Gold & Silver Refining Co., died Jan. 25, at the age of 45 years, of pneumonia in Hartwell, O., his late home. Mr. Byers was born in Kirkwood, Ill., and came here when a young man of 25 years. He made his business start in 1888 as a traveling man for Jacob Schwarz, originator of the Cincinnati Gold & Silver Refining Co. His territory was the north and west, which he had traveled for the past 20 years up to the time of his death. In 1894 he became a partner of the business, which is now conducted by W. H. Schwarz. Mr. Byers was not only an active business man, but was interested in whatever was for the welfare of his fellow man. He was a prominent member of the order of Masons as well as a member of the K. of P. The funeral was held Jan. 28 at his late home, and the interment took place in Spring Grove Cemetery. Deceased is survived by a widow, a son and a daughter.

Pacific Northwest.

B. L. Gates, Seattle, Wash., is interested in the development of gold prospects on Seattle beach.

Burnett Bros., Seattle, Chehalis and Aberdeen, Wash., have filed articles of incorporation, with a capital stock of \$150,000. L. H. Burnett, M. S. Burnett and Samuel Burnett are the incorporators.

The store of L. Alva Lewis, Klamath Falls, Ore., was recently damaged by fire, with a loss of about \$1,500. The fire is believed to have been of incendiary origin, set to cover a burglary, and is attributed to an Indian.

A man giving the name of William Foley was recently arrested in Walla Walla, by Chief of Police Davis, for passing a forged check for \$148 on K. Falkenberg, a local jeweler, in payment for a gold watch and diamond ring. He gave a check on a Salt Lake bank and showed a bank book in which he was credited with nearly \$3,500 in deposits. He also tried to pass forged checks on other business houses. Falkenberg took his check to the Baker-Boyer Bank, which found upon telegraphing to Salt Lake that Foley has no money on deposit there, and checks bearing his name were being returned every day to some place. When arrested Foley had in his possession other forged checks and a telegram from a confederate in Seattle warning him to get out of Walla Walla.

Gant & Jacob is the firm name of the business heretofore carried on by John Jacob, Murray, O.

M. H. COWEN.



M. A. COHEN.

F. C. EMERSON.



S. H. HESS.

A. E. MADSEN,
Headquarters 305 Nicollet Ave.,
Minneapolis, Minn.

Our Representatives for 1908

thank you for your liberal patronage during 1907, and will call on you again this year with the following lines :

DUEBER-HAMPDEN CASES AND MOVEMENTS
FAHYS CASES WADSWORTH CASES
SPRINGFIELD AND HAMILTON MOVEMENTS

“THE WATCH HOUSE”

RETTIG, HESS & MADSEN

We pay express charges
on mail orders

72 Madison Street, corner State Street
CHICAGO, ILL.

Los Angeles.

E. B. Smith and J. H. Padgham, both Santa Anna jewelers, were in this city last week.

A. E. Baranger, with E. W. Reynolds Co., has not yet returned from his trip through the North.

Henry M. Abrams, 717 Market St., San Francisco, Cal., was in this city last week on private business.

L. Roessler, of the H. J. Whitley Co., has been spending a week on a vacation and business trip to San Diego.

Oscar Barnum, formerly with J. Wiesenberger but recently of San Francisco, Cal., returned to this city last week.

Edward Gerson spent two days at Oxnard, Cal., last week. His plans for his new store have now been completed.

George L. Miller, recently with the H. J. Whitley Co., has returned to his former position as salesman with Montgomery Bros.

The J. C. Fleming Co. has been taking advantage of the dull days during the recent excessive rain to make the annual inventory.

Robert H. Gilmore, of Gilmore & Lee, started on Monday of last week for a trip of six or seven weeks through central and northern California.

R. H. Schwarzkopf, of the firm of Schwarzkopf & Penniman, was in Denver, Colo., last week, on his return from New York. He is expected here about Feb. 1.

W. Kley, lapidary and gem dealer, Denver, Colo., was in this city last week. He is making a tour through Southern California, intending to go from here to San Francisco.

J. J. Alexander, Seattle, Wash., has taken the place with Burr W. Freer, San Francisco, formerly held by Ed T. Willis, who recently bought out the store of E. L. Rice, Hollywood.

Ed Turner, traveling representative of the E. W. Reynolds Co., returned from Arizona last week, and again started on a tour to San Diego and other points of Southern California.

C. A. Gove, manager of the California Gem Co., has closed his store at 649 S. Spring St. He will continue his wholesale business and the operation of his factory at 1025 E. 41st St. He intends to spend a portion of his time visiting the outside trade.

Charles J. Walter has changed his optical department from the rear to the front of the store. He is still anxious to sell his business, but thus far has been unable to find a customer. He is suffering from rheumatism and is very anxious to retire from business.

The Sing Fat Co., dealers in jade jewelry, curios, bronze, carved ivory and other Chinese and Japanese art and fancy goods, which came here from San Francisco after the big fire in that city and occupied a portion of the Central Department Store, has now opened a large store for its own exclusive use at 548-550 S. Broadway.

Joseph T. Brennan, representative of Burr W. Freer, San Francisco, Cal., was here last week on his return from a trip to San Diego and other cities of Southern California. He reported that business con-

dition in this part of the State showed decided evidence of improvement. He was quite optimistic over the situation as he found it.

Indianapolis.

Wolf Sussman has opened a new retail store at 251 W. Washington St.

Awakening one night last week, Edward L. Beer, Rushville, found that burglars had left his rooms, taking an overcoat, some change and a watch he had repaired for a customer.

The Hoosier Jewelry Co., on N. Illinois St., has a window display that has attracted considerable attention. It is the wax figure of a boy with a watchmaker's repair table and tools before him.

Arthur Hutto, for several years with the Wadsworth Watch Case Co., Dayton, has taken a position with Burns & Anderson, manufacturing jewelers, with headquarters in the Commercial building.

Friends of Frank L. Bryant have received word that he will probably remain in the west six weeks or two months longer. He is making an extensive western trip with his wife, spending the whole time in sight-seeing and recreation.

Thieves early Sunday morning smashed the show window in the store of Carl L. Rost, diamond merchant, at 15 N. Illinois St., this city, and took diamonds and jewelry to the value of \$550, which were on display.

Muncie jewelers are uniting with other business men in urging that the boycott against the local street car company be ended. Street car employes are striking and persons living in the suburbs refuse to ride. As a result downtown merchants are doing little business.

Schedules have been filed with Albert Rabb, referee in bankruptcy, showing the individual and partnership liabilities and assets of S. T. Nichols & Co. The partnership liabilities are shown to be \$59,761.28, with assets of \$36,031.50. The schedule of Smith T. Nichols shows assets of \$20,958.26, with liabilities amounting to \$24,606.83. Frederick Nichols, in his individual schedule, shows liabilities of \$445.15 and assets of \$520. Albert Lorsch & Co., New York, are named as the principal creditors in the partnership schedule.

Under a New York date line last week a local newspaper published a story to the effect that diamonds were a drug on the market, and that they were so little wanted that pawnbrokers were lending only 10 per cent. of their value. As a result a number of diamond merchants last week were besieged by prospective customers carrying the clipping and expecting to buy diamonds at ridiculously low prices. Krauss & Sector, on N. Illinois St., who received a number of inquiries, said: "Diamonds are selling at the same price they were a year ago, and they are not going down, so far as Indianapolis is concerned. In fact, rough stones are selling at an advance of five per cent."

At a recent fire in Bennettsville, Marlborough County, S. C., S. J. Pearson, a retail jeweler of that place, lost his entire stock,

Kansas City.

Guy A. Esslinger, 113 W. 12th St., is suffering from the gripe.

J. R. Mercer and wife leave next week for their mid-winter trip to Texas.

E. Parker, Gilman City, Mo., is in this city, taking medical treatment.

C. P. Kionka, of Kionka & Kionka, has just returned from his honeymoon trip.

Ida Farver, Canton, Kans., has just enrolled as a student at the Polytechnic Institute.

Mr. Grady, of the Grady Jewelry & Optical Co., Stillwater, Okla., is in this city at present.

H. S. Dickey, Newton, Kans., is taking a course in watchmaking at the Kansas City Horological School.

J. H. Whitney, traveler for the Edwards & Sloane Jewelry Co., left last week for a trip over his Kansas and Nebraska territory.

H. P. Sutton, McCook, Nebr.; A. Wendover, St. Joseph, Mo., and E. B. Van Ness, Mound City, Kans., are spending this week at Excelsior Springs, Mo.

J. R. Mercer is taking his inventory this week, and reports the January business as having held up well, as compared with the same season of other years.

Jake Levin, formerly traveling representative for Kionka & Kionka, and well known to the retail trade in this section of the west, is now traveling for Martin, Low & Tausig.

Fred Chamberlain, with J. R. Mercer, has been elected secretary of the Interurban Land Co., which will have offices in the new Commerce building as soon as it is completed.

Most of the jewelry jobbers of this city are taking inventory this week, and some have their traveling salesmen in to help in the work. Most travelers, however, are out on the road.

Mr. Borsheim, a retail jeweler, of Omaha, Nebr., accompanied by his wife, passed through Kansas City, last week, while on the way to Arkansas. They stopped off here to visit their son, who is a jeweler in the employ of the Meyer Jewelry Co.

The following out-of-town jewelers called on the local trade, last week: Mr. Evans, manager of the Duke Jewelry Co., Fayetteville, Ark.; M. O. Squibb, Everton, Mo.; Mr. Arnold, of Arnold & Co., Texarkana, Ark.; Gustavus A. Carlson, Richmond, Mo.; J. H. Whiteside, Liberty, Mo.; W. S. Noble, Drexel, Mo.; A. Y. Boswell, Tulsa, Okla.; O. M. Atwood, Clifton, Kans.; H. L. Morrison, Pittsburg, Kans.; L. H. Hall, Trinidad, Colo.; F. W. Sellers, Wellington, Kans.; J. S. Lang, Coffeyville, Kans.; T. M. Goodnight, Crescent, Okla.

Thomas P. Farrington, Glenuulen, N. Dak., has moved his stock into a newly furnished store.

Frank W. King, a jeweler of Ferguson, Ia., had the honor of being elected mayor of that town at the last election. Mr. King is a young man, about 33 years old, married, and is popular in the community. He has been in the jewelry business in Ferguson as a jeweler and repairer for some years, and is considered one of the town's most enterprising merchants.

READ THE TESTIMONIAL LETTER UNDER THE PICTURE OF THE STORE



STORE OF ARCHIE TEGTMEYER, MILWAUKEE, WIS.

THE ARNSTINE BROS. CO.,
633 Rose Bldg., Cleveland, O.

[Copy of letter.]

Gentlemen:

The holiday rush being over, I herewith enclose you a remittance for my account, as there is no bill that we owe that we pay more cheerfully than we do yours.

This has been the fourth year that we have used your catalogue with splendid results. It gives me great pleasure to state that in spite of there being 20,000 men out of employment in this territory, that our business compares favorably with the month of December of a year ago and we attribute it largely to the good advertising that your catalogue has done for us, both in and out of the holiday season.

Wishing you a happy and prosperous 1908, I am,

Yours very truly,

ARCHIE TEGTMEYER.

We supply the Retail Jeweler with a Catalog of his own, at a moderate cost, that will be a credit to him, make his store the leading one and give it a prestige over all others.

Write for Information

THE ARNSTINE BROS. COMPANY

Makers of Catalogs only for Retail Jewelers

CLEVELAND, OHIO

San Francisco.

Felix Bloch, of Marx & Bloch, Portland, Ore., is in this city, visiting friends.

R. F. Allen, president of the Morgan & Allen Co., has just returned from New York.

Geo. F. Blakeslee, Tonopah, Nev., spent two days of last week in this city, on his way south.

W. H. Wichman, of Honolulu, H. I., passed through this city, last week, on his way to Europe.

S. Wurfkheim is fitting up his new offices in handsome style, putting in several capacious wall cabinets.

W. C. Hough, for many years with C. H. Wright, Eureka, Cal., will represent Krentz & Co. on the road.

Edson Adams, of the Dorrance-Battin Co., has been married, and has left for a trip to the Hawaiian Islands.

Mr. Mayer, of Mayer & Weinschenk, was ill last week, but has recovered sufficiently to enable him to be about the office.

Joseph Arnheim has left the service of J. Treager, Oakland, Cal., and will shortly start in business for himself in this city.

George Bromley, formerly of Butte, Mont., passed through this city last week, on his way to the Coos Bay district, to find a suitable location for a store.

Comparatively few out-of-town jewelers were in this city last week. Among them were W. C. Lean, San Jose, Cal.; Mr. Mount, of Mount & Ross, Petaluma, Cal., and A. G. Prouty, Napa, Cal.

S. S. Battin, Jr., coast representative of Krentz & Co., opened offices Jan. 1, in room 722, Shreve building. Joseph Coll, formerly with the Dorrance-Battin Co., is looking after the local business of Krentz & Co.

For the first time since the fire, Harold A. Forbes, Pacific coast representative of the Dueber-Hampden Watch Works, Canton, O., has opened an office in this city. He has located on the seventh floor of the Kamm building, adjoining W. R. Landram, and will soon lay in a stock of goods for the coast trade. He has been joined by Leon Price, formerly with George Greinzwieg & Co., who will cover a part of the outside territory, and will soon be on the road. Mr. Forbes will also leave in a few weeks to visit the outside trade.

Minneapolis and St. Paul.

Mr. Langdon, buyer of jewelry for the Powers Mercantile Co., Minneapolis, has gone east.

Henry A. Madigan, 88 S. Wabasha St., St. Paul, has given a bill of sale for his stock of jewelry to Nettie Osher.

White & McNaught, Minneapolis, have replaced their street clock, which was wrecked by a heavy dray a short time ago.

Anton Matczynski, St. Paul, recently found a pearl in a pail of oysters, which is said to be worth \$175. The pearl is as large as a pea.

Meyer Cohen & Co., Minneapolis, will remove to the new location at 412 Nicollet Ave., about March 1. The new location affords a much larger store and a better location, being in the center of the retail district.

Recent visitors from out of town includ-

ed: Messrs. Perry and Mattson, Eveleth, Minn.; O. D. Lcidal, Fergus Falls, Minn.; H. R. Shanks and wife, Castlewood, S. Dak.; C. A. Westerbaum, St. James, Minn.; J. A. L. Walman, Little Falls, Minn.

Milwaukee.

M. A. Braun, Frederick, Wis., has sold out.

At Nekoosa, Wis., August Robert is looking for a new location after closing his store.

The damage caused by fire to Maas, Fischebeck & Co., engravers for the trade, has been repaired. The loss was caused by a blaze in a moving picture theatre in the building occupied by the firm.

Theodore Schelle, 316 W. Water St., is planning the erection of a modern frame cottage on Maryland Ave., North Milwaukee. Hot water heating, hardwood finish and floors and modern plumbing will be among the conveniences supplied.

Among the new pupils at the Wisconsin Institute of Horology, are: Constantine Zambrozski, Milwaukee; Ernst Barber, Sturgeon Bay; C. Dulin, Wautoma, and Henry Girzi, Ishpeming, Mich. The latter returned for a post graduate course.

Secretary Franklin Thomson, of the Wisconsin Retail Jewelers' Association, announces that the membership signs of the association have been received and are being distributed rapidly. Payment of dues entitles the jeweler-member of the association to a sign.

Charles Hufschmidt, for several years traveling representative of Bunde & Upmeyer Co., Milwaukee, is receiving the condolences of his many friends upon the death of his father, Charles Hufschmidt, at Prairie du Chien, where for 30 years the deceased had conducted the famous old Dousman Hotel.

Among the out-of-town jewelers in Milwaukee, recently, were: H. W. Klopff, Neillsville; F. J. Cross, Cambria; John Armbruster, Cedarburg; F. D. Bancroft, Estberg & Sons, and J. B. Kimball, Waukesha; F. P. Beswick and O. E. Lange, Racine; Amidon Bros., Hartford; E. L. Fischer, Reeseville; Reinhold Hille, Menominee Falls; J. J. Ragatz, Prairie Du Sac; T. F. Dresen, Madison; P. S. Larson, Beloit; P. A. Clammer, Cresco.

Much approval is felt among jewelers in Milwaukee and Wisconsin for the proposed plan of establishing a committee to examine watchmakers and issue certificates. Jeweler Frederick H. Colburn, East Troy, Wis., is being urged to take up the matter, which he broached first at the initial convention of the State association, over two years ago. The Iowa association recently proposed the same plan in Iowa.

Notice has been given that the partnership consisting between I. Harrison and S. L. Harrison, under the firm name of the Arsenal Instalment Co., 43 State St., Detroit, Mich., was dissolved Jan. 1. I. Harrison retires and the business will be liquidated by S. L. Harrison, who assumes the liabilities of the old firm, collects all accounts and will continue in business at the same address. I. Harrison is now in business at 5157 Butler St., Pittsburg, Pa.

Omaha.

T. L. Combs has returned from a week's visit in Chicago.

John E. Morehouse, with the Kennedy Optical Co., Detroit, Mich., called on the local opticians, recently.

S. W. Lindsay donated a silver cup which was given as a prize at the Poultry Show, held recently in this city.

C. A. Hazelet, optician, of Kearney, Nebr., has taken a position with T. L. Combs & Co., as manager of the optical department.

Mr. Hiebenthal, of Hiebenthal & Preiss, Scribner, Nebr., was in the city last week purchasing gifts for his daughter, whose wedding takes place in the near future.

The firm of Fred Brodegaard & Co., began business Feb. 1 in their new wholesale and retail store at 109 N. 16th St. Representatives will soon start on the road.

During the night of Jan. 26 burglars entered the store of F. H. D'Arcy, Kalamazoo, Mich., and stole stock valued at \$10,000, including diamonds, watches and the better grades of jewelry.

The following out-of-town jewelers were in this city, last week, replenishing their stocks: H. D. Howard, Fairfield, Nebr.; J. D. Kite, Wymore, Nebr.; M. Tritsek, Louisville, Nebr.; A. Schlosser, Dodge, Nebr., and S. H. Clay, Long Pine, Nebr.

Columbus, O.

Word was received last week from Bowling Green to the effect that Harry Hart, James Smith and Marvin Parks, who were caught by Sheriff Roache, his deputies and a posse near that city, Nov. 16 last, after a gun fight, after they had robbed the jewelry store of J. P. Phillips of more than \$2,000 worth of goods, had pleaded guilty and were sentenced. Hart and Smith got five years in the penitentiary, and Parks, who is only 18, was sent to the Mansfield reformatory.

The bill to regulate the practice of optometry, drawn up by the Ohio Optical Association, has been introduced in the General Assembly, being intrusted to Senator Denman, who introduced it in the upper house. The bill establishes an "Optometry Committee of Examination," of five members, three opticians and two oculists, as a department of the State Board of Medical Registration and Examination. The optometrists are to be men recommended by the Ohio Optical Association. The members shall serve respectively one, two, three, four and five years.

Harrisburg, Pa.

Mr. and Mrs. L. A. Faunce returned last week from a brief visit to Philadelphia.

The Retail Merchants' Protective Association of Lebanon held its annual banquet Jan. 30. There were about 200 guests.

The first anniversary of Harrisburg Council, No. 358, an organization of Commercial travelers, was celebrated recently.

A joint meeting of the Retail Merchants' Association of the Lykens Valley was held in Lykens last week. A luncheon followed the meeting.

INDEPENDENT GOODS
SOLD BY AN
INDEPENDENT HOUSE
TO
INDEPENDENT JEWELERS

Lindenberg & Fox

31-39 East 4th St., CINCINNATI, O.

WHOLESALE JEWELERS

SPECIAL AGENTS FOR

The Illinois Watch Co. and Jos. Fahys & Co.

The best movements in the world

High grade cases

WE ARE STRICTLY A NON-RETAILING CONCERN

Let us increase your business by the installation of our
IMPROVED "AMERICAN BEAUTY" CASES

THE FIXTURE CLIMAX OF THE 20th CENTURY

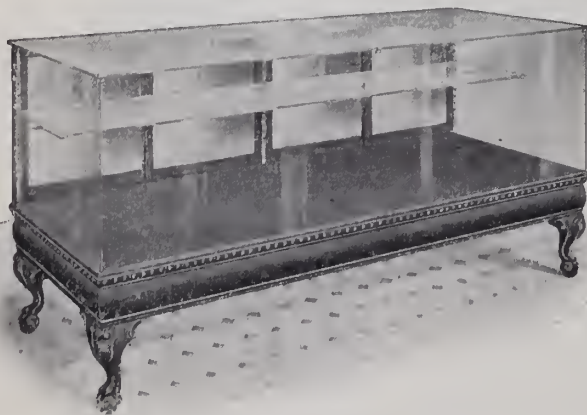

Our "American Beauty" Jewelers' Table
Display Case No. 408.

GRAND RAPIDS SHOW CASE CO. Grand Rapids, Mich.

NEW YORK OFFICE, 714 BROADWAY

Under our own management

Same floors as McKenna Bros. Brass Co.

The largest show case plant in the world

It is impossible for these cases to break from any cause due to construction. Not a hole bored in the glass at any point. Dust proof and will remain so.

We can furnish the highest grade interior fixtures at reasonable prices.

Write for our Catalogue C. Consult our designers.

An Elaborate Jewel Presented to Past Exalted Ruler of the B.P.O.E.

THE accompanying illustration shows a special jewel of a past-exalted ruler of the Benevolent Protective Order of Elks, made by the Elk Jewelry Mfg. Co. and presented by the Mount Vernon (N. Y.) lodge to Leon St. C. Dick, the retiring master, by the members of the lodge, in token of their friendship and esteem.

The badge is of enamel work set with dia-



JEWEL PRESENTED TO LEON ST. C. DICK.

monds and pearls, at the top is the name of Mr. Dick in engraved enamel, and beneath this are the words, "Past Exalted Ruler." From the bar, suspended by a dainty gold chain, is the emblem of the society surmounted by forget-me-nots made of pearls and diamonds, the flowers of the order. The emblem is surmounted by this wreath of forget-me-nots and within the wreath are the letters "B. P. O. E." Just above the emblem is a star on which the number of the lodge, 842, is engraved.

The design is original and reflects much credit on the makers.

Jewelry Considered as an Investment by People of the Levant.

OUR consul at Smyrna, E. L. Harris, reports that jewelry has always been greatly in favor among the Levantines, not only as a means of embellishment, but also as an investment. The consul adds:

"Even now, and in spite of the many savings banks which provide a safe and remunerative investment, people in the interior prefer to purchase jewelry, probably through a feeling of suspicion in turning their money into strange hands.

"Smyrna abounds in jewelers and goldsmiths, who are not, however, skilful in cutting and setting. Precious stones, especially diamonds, are imported in the rough state from Holland. It is difficult to value the amount imported, as the greater part of this article is smuggled in.



Case Screw Washer

URICH Perfect Fitting

Case Screw Washer

CASE SCREW WASHER

Easily adjusted and holds the movement securely even when case shoulder is worn away.

Prices: Gross, \$1.50; Package, 4 doz. assorted, 50c; single doz., 15c.

For sale at all material houses or direct

S. URICH, P. O. Box 1942, New York City



TRADE-MARKS

OF THE JEWELRY AND KINDRED TRADES.
Over 4,000 Marks. Second Edition. Price, \$3.00.
The Jewelers' Circular Pub. Co., 11 John St., N. Y.

The Dorst Company

SPECIAL MANUFACTURING JEWELERS

We have the best equipment in the West
for turning out Special Orders, Repairs,
Diamond Mountings, Emblem Goods, Etc.

S. E. Cor. 5th and Elm Sts. CINCINNATI, OHIO

Jos. Brown & Co.

5th Ave. and Madison St., Chicago, Ill.

Special Attention
Paid to :: :: ::

AUCTION SALES

GOODS FURNISHED FOR SALES ON MEMO. AT A SAVING OF
50 PER CENT.

If you do not correspond with us, your sale will not be a success.

WRITE US AT ONCE FOR PARTICULARS.

PANIC!

It No Longer Exists With the Enterprising Jeweler

MAKE your stock attractive by adding from the Many New Fads which we offer this season, and business will move right along.

LINDENBERG, STRAUSS & CO.
Cincinnati, Ohio

We carry the most comprehensive Line of Watches and we offer Special Inducements in Diamonds



"True Time for a Life Time."

Rockford Watches

The Most Profitable and Satisfactory
Watch for the Legitimate Jeweler.

WRITE TO-DAY FOR PRICE LIST AND ADVERTISING MATTER

ROCKFORD WATCH COMPANY, ROCKFORD, ILL.

Greatest Bargain Ever Offered

A LIMITED QUANTITY AT THIS PRICE ONLY. SEND YOUR ORDERS QUICK.

Sun Dial, 16 size, highly polished nickel case, fitted with the best American lever escapement, stem wind, and stem set movement. Each and every watch is timed and tested, regulated and fully guaranteed for one year.

PRICE, EACH, 55c.

IN CASE OF FIFTY (50) LOTS, EACH, 54c.

CASH WITH ORDER OR C. O. D.

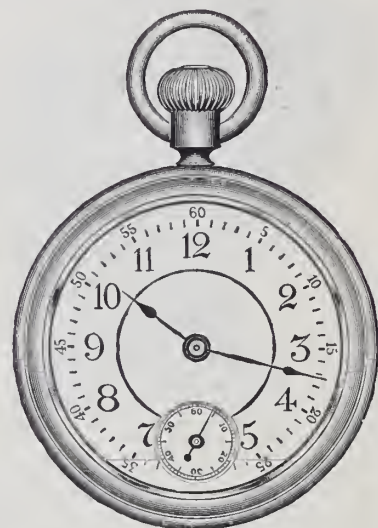

DANIELS & LESCH CO.

Wholesalers of Watches and Jewelry

164-166 East Madison St., CHICAGO, ILL.

JANITSCHKE COMPANY, INC.

33 UNION SQUARE, NEW YORK CITY

MANUFACTURERS
OF PATENTED

DIES

FOR THE SILVER AND
METAL TRADE

ARTISTIC CASTINGS OF EVERY DESCRIPTION
FOR THE SILVER AND JEWELRY TRADE

Specially adapted for Toilet Sets, Mirror and Brush Backs, Card and Cigarette Cases, Candlesticks, Plates, Large Trays, Hollowware, Stamping of Every Description, etc.

Iron Hubs and Bronze Forces, False Core Work and Undercut Castings with Elastic Patterns. Fine Plaster Castings by the *Janitschek Patent*, superior to the asbestos process.

TELEPHONE { 400 STUYVESANT
 { 401 STUYVESANT

Correspondence Solicited

AN ATTRACTIVE SHOW WINDOW IS THE JEWELER'S



Our New Dressed Bust.

best and only advertisement. Then why not use quaint and original up-to-date displays? We manufacture from the raw wood to the finished, polished or covered display that differs in pattern and shape from any other displays now on the market.

Exclusive and handsome designs, entirely new, at lower prices than have been charged for unattractive ones heretofore.



Our New French Bust.

OUR PATENT RING HOLDERS

Have Helped to Increase Sales for Others, WHY NOT FOR YOU?



Pat. Feb. 12, 1907. \$2.50 per Doz.

Among the many additions made to the exclusive designs and patents in our display stands, we have pending a Bracelet holder, which is the most original, most convenient, most practical and most effective stand on the market. It is made to hold from one to one hundred bracelets; the same is now on the road—ask to see it.



Pat. Feb. 12, 1907. \$2.50 per Doz.

DO YOU GET SATISFACTORY RESULTS FROM YOUR SHOW WINDOW? IF NOT CONSULT US



PART OF ONE OF THE LARGEST SHOW WINDOWS IN THE WORLD. DESIGNED AND EXECUTED BY US.

Schultz-Jerseemann Mfg. Co., 105 MAIDEN LANE, NEW YORK.

PATENT DEPARTMENT



[IN WHICH IS CONTAINED A LIST OF THE LATEST PATENTS GRANTED BY THE UNITED STATES AND GREAT BRITAIN, THE UNITED STATES PATENTS THAT HAVE EXPIRED AND THE REGISTERED TRADE-MARKS.]

UNITED STATES PATENTS.

ISSUED JAN. 21, 1908.

876,983. SAFETY DEVICE FOR JEWELRY. GEORGE LINCKS, Jersey City, N. J. Filed June 28, 1906. Serial No. 323,891.

The combination with an article of jewelry, of a hook secured thereto and having a shank, a keeper pivoted to the shank and corresponding generally

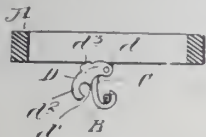

to the sape of the hook, spaced abutments formed upon the keeper positioned to define a recess registering substantially with the inner curvature of the hook, and a stop extending rearwardly and laterally from the keeper and positioned to engage the rear side of the hook and the article and to limit the movement of the keeper in both directions.

ISSUE OF JAN. 28, 1908.

877,888. JEWELRY-STAND. MONROE ENGELSMAN, New York. Filed Oct. 8, 1906. Serial No. 338,013.

The combination in a stand of a base, a handle supported on the base, a rod supported in the handle, a bifurcated lug extending from the rod, a pin fastened to the bifurcated lug, a disk-support carried on the pin, means to clamp the disk-

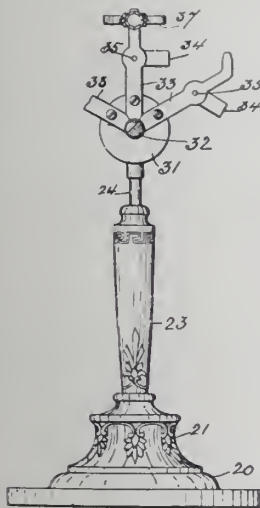

support at various angles on the pin, a disk clamped on the disk-support, means to hold the disk to the support in different angular positions, an arm for supporting an object fastened to the disk, and a tag adjustably secured to the arm.

877,881. ESCAPEMENT. GEORGE W. BENNUM, Georgetown, Del. Filed May 16, 1905. Serial No. 260,650.

In combination, an escapement wheel comprising a pair of pivoted disk members capable of revolution, a series of rollers mounted on the disks for independent revolution, pivoted pallets adapted to contact with said rollers, the contacting faces of said pallets being curved concentrically to the pivotal point thereof, and a verge rod connected to the pallets, the innermost edge of the pallets being

beveled, the face of the pallet below the engaging fingers thereof being outwardly and downwardly curved relative to said fingers, whereby a double

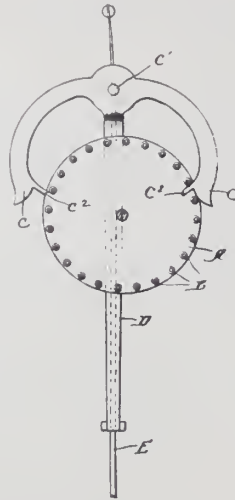

impetus will be given to the verge rod as the pallets move out of engagement with the rollers.

DESIGNS.

39,033. BADGE. LOUIS CALDWELL, East Orange, N. J. Filed Dec. 17, 1907. Serial No. 406,941. Term of patent 3½ years.



39,034. BROOCH OR SIMILAR ARTICLE. JOSEPH MARION ROSSI, New York. Filed Aug. 7, 1907. Serial No. 387,572. Term of patent 14 years.



39,035. BRACELET. SAMUEL MITCHELL, Newark, N. J., assignor to L. Fritzsche & Co., Newark, N. J. Filed Aug. 15, 1907. Serial No. 388,735. Term of patent 7 years.



39,036. BRACELET. SAMUEL MITCHELL, Newark, N. J., assignor to L. Fritzsche & Co., Newark, N. J. Filed Aug. 15, 1907. Serial No. 388,736. Term of patent 7 years.

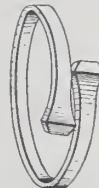

39,037. BRACELET. SAMUEL MITCHELL, Newark, N. J., assignor to L. Fritzsche & Co., Newark, N. J., assignor to L. Fritzsche & Co.,



Newark, N. J. Filed Aug. 15, 1907. Serial No. 388,737. Term of patent 7 years.

39,038. HANDLE FOR SPOONS, FORKS OR SIMILAR ARTICLES. GEORGE C. LUNT, Greenfield, Mass., assignor to the Rogers,



Lunt & Bowlen Co., Greenfield, Mass. Filed Dec. 16, 1907. Serial No. 406,785. Term of patent 7 years.

39,039. PLATE OR SIMILAR ARTICLE. GEORGE A. ALEXANDER, Philadelphia, Pa., assignor to Davis & Galt, Philadelphia, Pa. Filed Dec. 14, 1907. Serial No. 406,567. Term of patent 7 years.



UNITED STATES TRADE-MARKS.

[The following trade-marks have been adjudged entitled to registration under the Act of Feb. 20, 1903, and are published in compliance with Section 6 of said act. Said section provides:

"Any person who believes he would be damaged by the registration of a mark may oppose the same by filing notice of opposition, stating the grounds therefor, in the Patent Office, within 30 days after the publication of the mark sought to be registered, which said notice of opposition shall be verified by the person filing the same before one of the officers mentioned in Section 2 of this act. If no notice of opposition is filed within said time the commissioner shall issue a certificate of registration therefor, as hereinafter provided for."

Marks which are stated to have been "Used 10 years" are registrable under the last proviso of Section 5 of said act, which is as follows:

"And provided further, that nothing therein shall prevent the registration of any mark used by the applicant or his predecessor, or by those from whom title to the mark is derived, in commerce with foreign nations or among the several States, or with Indian tribes, which was in actual and exclusive use as a trade-mark of the applicant or his predecessor from whom he derived title for 10 years next preceding the passage of this act."]

PUBLISHED JAN. 28, 1908.

Ser No. **26,720.** (CLASS 28. JEWELRY AND PRECIOUS METAL WARE.) C. A. MARSH & Co., Attleboro, Mass. Filed April 15, 1907.



Particular description of goods.—Fobs, lorgnettes, necklaces, neck-chains, vest-chains, bracelets and chatelaine-pins.

UNITED STATES PATENTS THAT HAVE EXPIRED.

[Reported especially for THE JEWELERS' CIRCULAR—WEEKLY by R. W. Bishop, Patent Attorney, Washington, D. C.]

Issued Jan. 27, 1891.

445,172. WATCH CASE PENDANT. D. E. GRANT, Quebec, Can.

445,182. WATCH. JOHN JOHNSON, Baton Rouge, La.

445,196. PAPER-CUTTER AND BOOK-MARK.

FREDERICK W. GESSWEIN



The Late F. W. GESSWEIN
Founder of the Jewelers' Tool and Supply Business
1868

90 NASSAU STREET, NEW YORK

Manufacturer and Importer of and Dealer in

FINE TOOLS

FILES, SAWS, BRUSHES, MACHINERY
AND SUPPLIES FOR JEWELERS, SILVER-
SMITHS, WATCH CASE MAKERS, EN-
GRAVERS, POLISHERS, OPTICIANS AND
METAL WORKERS.



FREDERICK W. GESSWEIN
Son of the late F. W. Gesswein
1908

EVENTFUL YEARS

IN THE HISTORY OF THE

GESSWEIN TOOL BUSINESS

- 1868—The founding of the Gesswein Tool Business by the late F. W. Gesswein
1888—The untimely closing of the remarkable career of the one who by twenty years of industry had made the name "Gesswein" famous wherever jewelers' tools were made or used.
1908—Frederick W. Gesswein is the only concern entitled to sell goods under the name Gesswein. Successful termination of an action awarding to Frederick W. Gesswein the use of that name.

The facilities of this house for manufacturing and importing are unexcelled.

The spacious factory is equipped with the most modern machinery and manned by expert operators, many of whom worked under the founder of the business, the late F. W. Gesswein.

ORDERS FOR
SPECIALTIES
SOLICITED



Frederick W. Gesswein, through his extended study of fine tool manufacturing in Switzerland, France and Germany, not only acquired a thorough knowledge of the methods there employed, but also secured valuable agencies for tools of European make, including SWISS FILES, FRENCH PLIERS and TOOLS, GERMAN SAWS, Etc.

QUALITY
RIGHT PRICE
PROMPT DELIVERY

THE ONLY GESSWEIN TOOL HOUSE

BARGAINS

If you want genuine bargains for your Jewelry Business, be sure you write for the Bargain edition number of our new

— CATALOGUE —

which absolutely quotes the lowest prices on reliable goods, such as

WATCHES
SILVERWARE

JEWELRY
DIAMONDS

HOLIDAY
NOVELTIES, ETC.

Mailed to legitimate jewelers only for the asking

HOLSMAN & ALTER

176-178-180 East Madison Street
Chicago, Ill.

T. H. PERRY, Indianapolis, Ind.

- 445,200 and 445,201. INKSTANDS. E. S. RAFF, Canton, O.
- 445,216. POCKETBOOK. A. Y. ANDREWS, Philadelphia, Pa.
- 445,317. FOUNTAIN-PEN. G. H. JONES, London, England.
- 445,370. BELL. N. N. HILL, East Hampton, Conn.
- 445,373. POCKETBOOK. CHARLES JOSEPH, New York, assignor to Rose Joseph, same place.
- 445,509. POCKET-KNIFE. C. P. THAYER, Holbrook, Mass.
- 445,512. CUFF-FASTENER. L. A. NEGRAVAL, Jersey City, N. J., assignor to H. C. Frank and Henry Gutmann, New York. Designs issued Jan. 29, 1901, for 7 years.
- 33,980. PURSE. NANNIE R. MITCHELL, Paris, Ky.
- 33,982. FORK. C. F. SMITH, New Britain, Conn., assignor to Landers, Frary & Clark, same place.
- 33,987. CARAFE. J. D. BERGEN, Meriden, Conn.

BRITISH PATENTS.

(ABRIDGMENTS OF SPECIFICATIONS, 1906, FROM *The Illustrated Official Journal.*)

ISSUE OF JAN. 8, 1907

20,787. TIME-RECORDERS FOR WORKMEN. M. W. SMITH, Hoddesdon, Herts. Sept. 19. The time sheet is carried on a clock-driven vertical drum and is divided by vertical lines into hours and quarters, and by horizontal lines into spaces for workmen, each such space being further subdivided horizontally into six working days. The drum is vertically shifted at the end of each day to allow the vertically-arranged row of recording-points to traverse the spaces in turn. The points are operated electrically or mechanically as the workman removes or replaces the check or its peg. The drum *a* is mounted on a shaft *b* driven

pointed articles is made of iron or steel, and is



magnetized to cause it to adhere to the pin A, which is also magnetized.

21,179. SUNDIALS. C. A. JENSEN, Middlesex. (W. M. Homan, Bethlehem, Orange River Colony.) Sept. 24.

The gnomons of which two are used, one for each half year, are shaped so that the mean time

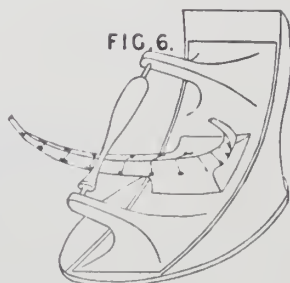

may be read by the same side of the shadow throughout the year on an equatorial arc having a V-section. A perspective view of the complete instrument is shown.

21,206. ELECTRIC SWITCHES. R. F. S. VENN and R. C. GRIESBACH, both of Westminster. Sept. 25.

Electric time-switches are provided with automatic selective devices, in order to render them inoperative at certain times, consisting of a star-wheel *s*, Fig. 2, the arms of which are provided with pins *x* of varying lengths or at different distances from the center. This wheel is rotated by a clock arm H, and at the selected time engages with and tilts a bell-crank lever *o*, which prevents the detent C from operating the switch until the lever *o* is released by a further rotation of the wheel. In the modification shown in Fig. 4, the pins on the wheel *s* engage with a lever *o*², the detent *o*³ of which engages with a peg N² on the switch lever E² and so prevents the contact K from falling into the mercury cup M. When the lever *o*² is detent *o*³ is drawn away from the peg N² by a spring and the switch may then be operated.

21,245. BRACELETS. S. SIMON, London; J. OTT (trading as Kuttroff & Volz, Nachfolger, Pforzheim, Germany.) Sept. 25.

In an expanding bracelet, a circular, oblong, etc., tubular link A has an internal slot all round to receive sliding cross-bars E, controlled by



springs C and mounted on connecting-links D. The links D may be guided by flanges F and connected together by ornamental links G. The cross-bars E may be hidden by ornaments, attached to them, or extending across the link A.

21,285. FASTENINGS FOR LOCKETS, ETC. B. R. SIMMONS, Birmingham. Sept. 26.

A locket, stamp case, combination locket and

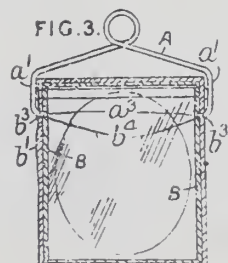

stamp case, match box, etc., is fastened by means of a spring wire connecting-piece A with arms *a*¹ having evenly bent-in ends *a*², which pass through

holes *b*² in the body *b*¹ and spring into holes *b*⁴ in the lid B to fasten it. The lid is opened by the spring D, after turning back the part A, so that

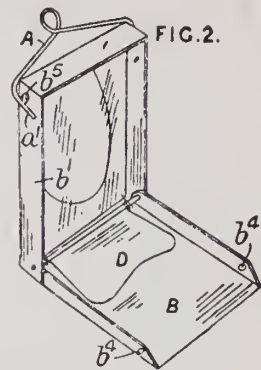

the rounded studs *b*⁵, bearing on the arms *a*¹ withdraw the ends *a*². The spring D also serves to keep stamps, etc., in place.

Complete specifications accepted Dec. 27, 1907. 1907.

7,530. FOUNTAIN PEN. SHAND.
22,604. HAT-FASTENER. CALHOUN.

Complete specifications accepted Dec. 31, 1907. 1906.

29,670. BROOCH. SHANKS & COURLANDER. 1907.

1,284. CANDLE-HOLDER. LEHMANN.
1,889. STUD. DARLEY.

6,826. WIRE FOR JEWELRY. ZYTO.
9,441. COLLAR BUTTON. MASON.

11,636. BROOCH. WALL.
14,604. BUTTON. HUBMAJER.

16,706. EYEGLASSES. IVE.
17,950. HAT-SECURER. PINTHER.

22,933. FIELD-GLASSES. OGILVY.

Applications filed Dec. 16, 1907, to Dec. 31, 1907.

27,697. CIGARETTE CASE. JOHN DARLING and JOHN DARLING, JR., Glasgow.

27,705. FOUNTAIN-PEN. FREDERICK ILLINGWORTH and W. F. JOHNSON, London.

27,808. SAFETY-PIN. K. G. DIETRICH, London. Complete specification.

27,832. TIME-RECORDER. SAMUEL RANDELL, London.

28,059. HAT-PIN. A. E. MANSELL, London.

28,233. PENDANT. CLARENCE FLINT, Birmingham. Complete specification.

28,236. CLOCK-REGULATOR. THOMAS ADAIR, Belfast, Ireland.

28,463. COFFEE URN. HARRIS & SHELDON and ADOLFO FISSLER, Birmingham.

28,623. ALARM CLOCK. MARY J. GALLAGHER, London.

28,674. COLLAR-BUTTON. THOMAS NORTON, Birmingham.

28,691. BRACELET. MORITZ CASSEL, Essen-on-the-Ruhr, Germany. Complete specification.

28,731. SPOON OR FORK HANDLE. J. S. D. MACCORMAC, London.

Applications filed Jan. 1 to Jan. 4, 1908.

75. BRACELET FASTENING. SAUL BETTS, London.

169. HAT-PIN. WALTER KEENE, Hanley, Staffs.

200. BRACELET-SNAP. SAUL BETTS, Finsbury, London.

The store of Albert Stuwe, 376 Main St., Norfolk, Va., was broken into, about a week ago, by burglars, who stole stock valued at \$2,000. The stolen property includes; 70 gold watches, 12 cases of gold rings and a few diamonds, several gold bracelets, necklaces and cuff buttons and about a dozen silver match cases. Two opticians have been arrested on a charge of having committed the crime.

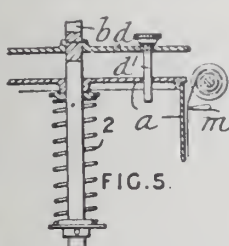
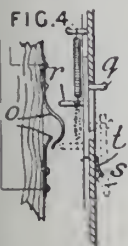

by a spring drum through a pinion *b*¹. The speed is controlled by a toothed wheel *d* geared to the clock, the vertical motion of the drum being permitted by a pin *d*¹ on the wheel *d* engaging a hole in the drum. For the daily setting, a six-step cam *i* on the shaft lifts a supporting-plate *h*¹, which is loose on the shaft *b* and is held from rotating by an arm with a guide-pin *h*², the cam being driven by a pin-wheel *k* on a countershaft *j*² geared to the shaft *b*. A spring *2*, Fig. 5, may be fitted to lessen the shock. The pegs for the checks are carried on

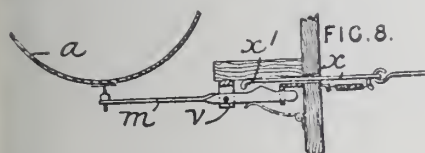

spring slides *q*, Fig. 4, having nose-pieces *r* to operate a contact-device *o*, the slide being retained in the lowest position by a catch *t* which engages a projection *s* on the check. The recording-fingers *m* are attached to the armatures of electromagnets connected to the corresponding contact-devices. The fingers may be operated directly from the pegs, as shown in Fig. 8; the finger is mounted on pivots *v*, and each has a double incline, which is engaged by a nose *x*¹ on a spring slide *x* operated by a link and a bell-crank from the corresponding peg.

ISSUE OF JAN. 15, 1908.

21,061. POINT-PROTECTORS FOR PINS, ETC. R. H. H. MARSH, Osmaston Road, Derby. (R. H. Proudlock, Beauchamp Estate, Mauritius.) Sept. 22. No patent granted (sealing fee not paid). A point-protector B for hat-pins and other sharp-



J. POUYAT
Limoges

Pouyat China

J.P.
L.
FRANCE



Look for the Pouyat Marks

Three excellent reasons for choosing **POUYAT** china:

- (1) It offers the greatest variety of really artistic forms and colorings.
- (2) Its beauty is perfectly protected for generations by the peculiar "*Pouyat Glaze*," which cannot be cut or scratched in use.
- (3) It is not extravagantly high priced.

The Cross of the Legion of Honor—indisputable evidence of highest achievement—has **FIVE TIMES** been bestowed by the French Government upon successive heads of the "*Pouyat*" house since its foundation in 1783.

An informing little treatise on Porcelain, old and new, will be sent to any address free of cost. Please write for Booklet No. 1E.

PAROUTAUD & WATSON
Representing *J. Pouyat*

37 Murray St.
New York



IMPORT **L. W. LEVY & CO.** COMMISSION
580-582 Broadway, New York

IMPERIAL LORNETTES GUN METAL NOVELTIES COMBS FANS Statuary	BOHEMIAN GOLD GLASS TEPLITZ WARE HAND PAINTED CHINA SILVER DEPOSIT GLASS IMPERIAL ELECTROLIERS Tobacco Jars Steins Whiskey Flasks	VANITY AND CARD CASES CORAL AND GARNET SPECIALTIES JET NOVELTIES SOUVENIR ARTICLES Smokers' Articles Stationery Sets Elks and Elk Souvenirs
--	--	---



PORCELAINS FANCY FRAMES	TRAVELING CLOCKS NOVELTY CLOCKS	LAFAYETTE OPERA and FIELD GLASSES	NOVELTY BAGS	{ German Silver, Sterling Silver { Gold Plated, Gun Metal	IMPORTED NOVELTIES Jade, Coral, Cameos, Etc.
----------------------------	------------------------------------	--------------------------------------	--------------	--	---

INDEX TO ADVERTISEMENTS.

A. & Z. Chain Co.	31	Grout's Excelsior Sign Co.	242	Ostby & Barton Co.	39
Abel Bros. & Co.	112	Gugenheim, M.	156	Owauda Cut Glass Co.	240
Adams, T. W., Co.	46	Hagerstrom Co.	44	Page-Davis Co.	184
Aikln-Lambert Co.	16	Hagstoz, T. B., Ltd.	247	Papazien, A. D.	218
Allsopp & Allsopp	55	Hahn, E., & Co.	108	Paroutaud & Watson	180
Allsopp Bros.	56	Hammel, Riglander & Co.	249	Pave & Baker Mfg. Co.	60
Alvin Mfg. Co.	2	Harris & Harrington	218	Penfold, Wm. C., Co.	214
American Gem & Pearl Co.	96	Haskell, Henry C.	226	Peninsular Engraving Co.	17, 18
American Platinum Works.	23	Hedges, A. J., & Co.	48	Potter & Buffinton Co.	32
American Watch Case Co.	203	Hedges, Wm. S., & Co.	110	Price, Cyrus, & Co.	116
Anderson, P. E., & Co.	240	Heintz Bros.	106	Prior, Charles M.	226
Arch Crown Mfg. Co.	54	Heller, L., & Son.	106	Providence Stock Co.	38
Arnold Klement Co.	62	Herpers Bros.	236	Prybil, P.	162
Arizona Turquoise Mines Co.	54	Hight Mfg. Co.	246	Pryor Mfg. Co.	44
Arnstein Bros. & Co.	102	Hill & Schmidt	53	Racine, Jules, & Co.	226
Arnstine Bros. Co.	170	Himalaya Mining Co.	120	Ranlett & Lowell Co.	218
Aronson & Spiegel	60	Hirsch & Hyman	114	Rauch, Louis	61
Aurora Silver Plate Mfg. Co.	41	Hodopyl & Walker	110	Reichhelm, E. P., & Co.	236
Austin, John, & Son.	248	Hoffman Novelty Co.	242	Reichman, A.	114
Austin & Stone	29	Hohenstein Co.	162	Reinzehausen, W. F., & Co.	247
Avebeck, M. J.	63	Hold-On Clutch Co.	42	Reitig, Hess & Madsen	168
Bagg, Perine & Co.	110	Holsman & Alter	178	Revell, A. H., & Co.	224
Balley-Filson Co.	62	Hooper, H. J.	185	Rice s, Bernard, Sons.	158
Baker, Geo. M.	246	Hopkins, E.	114	Richards, J. M.	114
Bail, Webb C., Watch Co.	202	Hotel St. James	240	Richardson, Enos, & Co.	52
Bassett Jewelry Co.	28	Howard's, S. E., Son & Co.	152	Ringgold, Howard	224
Bates & Bacon	30	Hraba, Louis W.	224	Robbins, Chas. M., Co.	36, 37
Baw & Dotter	238	Hutchison & Huestis	25	Robert, E. E.	185
Berge, J. & H.	60	Illinois Watch Co.	164	Rochelle Clock Co.	216
Signey, S. O., & Co.	6	Ingersoll, R. H., & Bro.	193	Rockford Silver Plate Co.	41
Bluffs, Chester, & Son.	84	International Gem Co.	120	Rockford Watch Co.	174
Bippart, Griscorn & Osborn.	53	International Silver Co.	20, 23	Roger Williams Silver Co.	130
Bishop, R. W.	224	Irons, Joseph	185	Rogers, Lunt & Bowlen Co.	130
Blackinton, R., & Co.	21	Irvine Cut Glass Co.	240	Rohrbeck, John E.	184
Bolles, Wm., Co.	246	Jacot Music Box Co.	240	Roseman, A.	120
Bonet, L.	56	Jalomack, M. L.	192	Rosenfeld, Wm. I.	94
Bennett, J. P., & Son.	50	Janitschek Co.	175	Rothschild Bros. & Co.	58
Borzinner, S., Co.	226	Jeanne, F. A.	108	Roy Watch Case Co.	226
Borrelli & Vitelli	100	Jorgeson, F. C., & Co.	58, 224	Rudolph & Snedeker	218
Bowden, J. B., & Co.	56	Juergensen, Jules	218	Rupp, C. F., & Sons.	187
Bradley Polytechnic Institute	193	Kahn, L. & M., & Co.	102	Saart, W. H., Co.	24
Brassier & Co.	128	Kock, Herman, Mfg. Co.	104	Sadler, F. H., Co.	161
Breitenbach, C. G., & Co.	40	Keller Jewelry Mfg. Co.	14, 15	Saunders, Meurer & Co.	110
Briggs & Dodd	190	Kelly & Steinman	242	Schickerling Mfg. Co.	56
Bristol Mfg. Co.	6	Kent & Woodland	50	Schultz & Co., Inc.	128
Brown, Jos., & Co.	173	Ketcham & McDougall	64	Schultz-Jerseman Mfg. Co.	176
Bryant, M. B., & Co.	158	Keystone Watch Case Co.	198	Sessions Clock Co.	218
Byron & Vail	57	King, Hugh E.	191	Simmons, R. F., Co.	26
Cahone, Geo. H., Co.	150	Kinney Co.	61	Simpson, Hall, Miller & Co.	20
Carter, Howe & Co.	51	Kirby, H. A.	138	Smith, Alfred H., & Co.	88
Chatham National Bank	144	Klipper Bros.	214	Smith, C. Sydney, Co.	59
Chicago Art Metal Works	55	Kohlbusch, Herman, Sr.	184	Smith, Frank W., Co.	122
Chopard Freres	43	Kohn, Alois, & Co.	53	Smith, Wm., & Co.	60
Cincinnati Gold & Silver Refining Co.	58	Kremenz & Co.	49	Snow & Westcott	50
Cohen, J. J.	108	Krower, Leonard	61	Sohn & Hyman	120
Conley & Straight	246	Laudis, M. L.	236	Solderine Co.	236
Cooper & Forman	120	Laugendorf Watch Co.	218	Solidarity Watch Case Co.	11
Corneisen, C.	57	Larter & Sons	68	Spencer, E. L., Co.	27
Cottle, S., Co.	51	Lechler, E.	51	Star Watch Case Co.	12
Crees & Court	248	Lederer, S. & B., Co.	62	State Bank	140
Crohn, M.	53	Loes & Sanders	247	Steiner, Louis	240
Cross & Bequelin	13, 138	Leiman Bros.	248	Stern Bros. & Co.	90, 250
Crossman, Chas. S., & Co.	Inside back cover	Lejong, L., & Bro.	246	Stern & Corn.	163
Crossman Co.	106	Lewy, L. W., & Co.	180	Sternau, S., & Co.	34
Crouch & Fitzgerald	240	Lewy & Cohen	187	Stilwell, L. W.	224
Culman, C.	193	Liberty Bank	142	St. Louis Watchmaking School	60
Daniels & Lesch Co.	175	Lindenberg & Fox	172	Street, Geo. O., & Sons	51
Day, Clark & Co.	54	Lindenberg, Strauss & Co.	174	Sussfeld, Lorsch & Co.	226, 242
Deacon, Louis J.	56	Lisner, D., & Co.	45	Swartzchild & Co.	166
Dederick's, James H., Sons.	246	Lissauer & Co.	114	Tavannes Watch Co.	158
Depasse Mfg. Co.	148	Lorsch, Albert, & Co.	102	Thomas, Seth, Clock Co.	208
Dixon, Wm., Inc.	247	Lowe, Edwin, & Co., Inc.	39	Title Guarantee & Trust Co.	140
Doran, Bagnall & Co.	35	Lyons Mfg. Co.	37	Trout, Charles L., & Co.	55
Dorflinger, C., & Sons	240	Maiden Lane Realty Co.	Inside front cover	Turner, John F.	185
Dorst & Co.	173	Maintien Bros. & Elliot	156	Untermeyer-Robbins Co.	160
Draper, O. M., Estate.	33	Manning, Bowman & Co.	126	Urich, S.	172
Dubois Watch Case Co.	193	Market & Fulton National Bank.	140	U. S. Smelting & Refining Works.	246
Dueber-Hampden Watch Co.	10	Marson, A.	248	Vacheron & Constantiu	185
Dunn, T. G., Co.	160	Mayer, Jos., & Bros.	161	Van Dam, Eduard	104
Durand & Co.	50	Mehmert, Joseph	193	Van Dusen & Stokes Co.	184
Eden, C. H., Co.	159	Mercantile National Bank	141	Van Schoor, C.	84
Elchberg & Co.	120	Meriden Britannia Co.	23	Wachter Mfg. Co.	212
Eisenmann Bros.	110	Merrill Bros. & Co.	154	Waddell, J. P., Show Case & Cabinet Co.	224
Elgin National Watch Co.	196	Meyerowitz Bros.	104	Wadsworth Watch Case Co.	7
Elk Jewelry Mfg. Co.	47	Miller, Fuller & Whiting Co.	35	Wagner Comb Mfg. Co.	56
E. P. H. Chain Catch.	60	Miller, L. A.	61	Waite-Thresher Co.	64, 65
Fahys, Joseph, & Co.	3	Mitchell & Titlston	189	Wakefield & Seler Co.	154
Feldenheimer, Louis	120	Mount & Woodhull	86	Waltham Watch Co.	194
Fisbel, Nessler & Co.	43	Murray, Dan I.	188	Washburn, C. Irving	54
Forman Co.	248	Myers, S. F., Co.	58	Waterman, L. E., Co.	244
Foster, Theodore W., & Bro. Co.	66	Nassau Bank	140	Wells, Chester H.	120
Freund, Henry, & Bro.	38	New England Watch Co.	204	Wendell & Co.	8, 9
Friedlander, R., L. & M.	108	New Haven Clock Co.	216	Western Clock Mfg. Co.	210
Galaway, J. H., & F. H.	53	New York Jewelry Purchasing Co.	55	Wheeler, Hayden W., & Co.	108
Garraud & Griser	108	New York Standard Watch Co.	200	Whiting & Davis	40
Gates, A. E.	186	Nissen, Ludwig, & Co.	110	Whiting, F. M., & Co.	60
Gesswein, Frederick W.	178	Noel, Rudolph, & Co.	106	Whiting Mfg. Co.	19
Gillette Sales Co.	124	Oneida Community, Ltd.	22, outside back cover	Wightman & Hough Co.	58
Gladsmith, C. P., & Co.	42	Oppenheimer, B.	50	Wodiska, Julius	65
Goodfriend Bros.	98	Oppenheimer Bros. & Veith.	104	Wolcott Mfg. Co.	31
Goeham Co.	136	Oppenheimer, H. E., & Co.	118	Wollstein, L. & M.	246
Grabemann, Herman	218	Oskamp, Clemens, Co.	65	Wood, Chas. F., & Co.	92
Grand Rapids Show Case Co.	172	Oskamp-Nolting & Co.	58	Wood, J. R., & Sons.	4, 5
Greene, Wm. C., Co.	36	Osmers-Dougherty Co.	52	Woodside Sterling Co.	146
Griffoul, August	61	Osmun Parker Mfg. Co.	50	Worley, Allsopp & Bliss Co.	45
				Zarembowitz, A.	236
				Zimmern, Henry, & Co.	248

Special Notices.

Payable invariably in advance.

Rates 75c. per insertion for notices not exceeding 25 words; additional words, 2c. each.

SITUATIONS WANTED, 1c. a word each insertion; minimum charge, 25c.

Heavy type, 5c. a word; minimum charge, \$1.25. Display cards, \$2.00 per inch.

In all cases, if answers are to be forwarded, 10c. extra to cover postage must be enclosed.

All answers to advertisements addressed care The Jewelers' Circular-Weekly, should be sent to the New York Office, unless the Chicago Office is specifically mentioned.

Situations Wanted.

POSITION WANTED by copper plate engraver. Address "X., 2964," care Jewelers' Circular-Weekly.

WATCHMAKER and jeweler; four years' experience; A1 reference. Address R. L. Winchest, Phillips, Wis.

YOUNG MAN wishes position to travel with or as salesman; best references. "I. S.," 205 W. 118th St., New York.

WATCHMAKER, engraver and salesman; young man, single, no bad habits; A1 references. Address C. W. Helm, Franklin, Tenn.

EXPERT WATCHMAKER, 15 years' experience; temperate habits; reference exchanged. Address J. F. Giffen, Box 4, Bemis, W. Va.

ENGRAVER and clock repairer; good references and samples furnished. Address "J. E. L., 3221," care Jewelers' Circular-Weekly.

YOUNG MAN, 20, five years' experience with jewelry house, desires position at anything. "Z., 3250," care Jewelers' Circular-Weekly.

YOUNG MAN, 20, experienced, desires position in wholesale jewelry house; references. Address "W., 3246," care Jewelers' Circular-Weekly.

YOUNG MAN, 18, three years' experience at jeweler's trade, wants position to finish learning. Address "I., 3232," care Jewelers' Circular-Weekly.

SALESMAN wishes position on the road with a manufacturing house or a silverware concern. Address "D., 3261," care Jewelers' Circular-Weekly.

WANTED, a position as plater, gilder and polisher on sterling silver, or nickeling, brassing, etc. Address "Plater, 3216," care Jewelers' Circular-Weekly.

A1 JEWELER and engraver is open for a position after March 1; am able to take complete charge of shop. Address "M., 3182," care Jewelers' Circular-Weekly.

YOUNG MAN wishes position as salesman, order or stock clerk in wholesale, retail jewelry or silver house. Address "X., 3072," care Jewelers' Circular-Weekly.

PLATER, colorer and etcher, experienced on jewelry, silver and metal novelties, desires steady position. Address "H., 3208," care Jewelers' Circular-Weekly.

WANTED, POSITION by first class watchmaker, competent in every detail, able to take charge of department. "J. R. L., 3271," care Jewelers' Circular-Weekly.

JEWELER, first class man, experienced in repairs, new work, polishing, coloring, etc., desires position. Address "D. W., 3202," care Jewelers' Circular-Weekly.

POSITION WANTED, at once, by engraver; willing to assist at waiting on trade; can furnish best of references. Urban J. Dean, 311 Columbia St., Elmira, N. Y.

FIRST CLASS jeweler wants position in store or factory; experienced in all kinds of jewelry, general work and repairs. Berkowitz, 1910 Douglass St., Brooklyn, N. Y.

YOUNG MAN, 22, jeweler, wishes position in south or west; seven years' experience; do new work and repairing. Charles Rosenberg, 91 Pulaski St., Brooklyn, N. Y.

YOUNG MAN, 23, designer, jeweler and stone setter, can also do outdoor selling, wishes a position; able to take care of shop. Jos. Edelman, 119 W. 115th St., New York.

FIRST CLASS watchmaker, with tools, desires position at once; middle age man; competent to handle railroad work. Address "E. H. B.," 45 Charles St., Springfield, Mass.

ENGRAVER, monograms, inscriptions, etc., on silverware and jewelry; good workman; 15 years' experience; New York City only. "R., 3176," care Jewelers' Circular-Weekly.

ENGRAVER, well experienced in lettering on silverware and jewelry, wishes steady position; will work on percentage. Address "C., 3214," care Jewelers' Circular-Weekly.

A YOUNG MAN, thoroughly familiar with the jewelry business, desires a position with a wholesale house; A1 reference. Address "O., 3255," care Jewelers' Circular-Weekly.

PERMANENT POSITION by young man, first class watchmaker, jeweler and monogram engraver; married. Address W. L. Primrose, 125 S. 7th St., Grand Junction, Colo.

YOUNG MAN, 23, wants position as assistant watchmaker; four years' experience on watch, clock and jewelry repairing; best references. Address F. Berger, Newark, N. Y.

EXPERIENCED WATCHMAKER and engraver would like steady position in first class store; desires a change; east preferred. Address "C., 3268," care Jewelers' Circular-Weekly.

WATCHMAKER, first class workman, with best references, own tools, wants position at once; New York or country, south preferred. "A., 3258," care Jewelers' Circular-Weekly.

OFFICE MANAGER, confidential assistant, capable of taking charge of business; 11 years' experience; best recommendations. Address "W., 3187," care Jewelers' Circular-Weekly.

POSITION WANTED by young man of neat appearance in retail jewelry store; fine salesman; five years' experience; best reference. "Honest, 3223," care Jewelers' Circular-Weekly.

A FIRST CLASS watchmaker, 22 years' old, wants a position at once; speaks German only; experienced in high grade work. Address "I. R., 3219," care Jewelers' Circular-Weekly.

WANTED, manufacturer's or general jobber's line of jewelry for middle west, by salesman with trade over this territory. Address "Hustler, 3243," care Jewelers' Circular-Weekly.

FIRST CLASS clockmaker and all around man wants to make a change; 12 years with present employer; married, age 34; references. M. P. Boggs, 500 Collins Ave., Pittsburg, Pa.

WANTED, POSITION as saleslady in first class retail jewelry store; 17 years' experience; can furnish best reference. Address Miss C. L. Gauslin, J. Juneau Court, Milwaukee, Wis.

ENGRAVER, first class, monograms, inscriptions, cyphers, old English, script, crests, coat-of-arms, carving; excellent references. Address "R. C. C., 3218," care Jewelers' Circular-Weekly.

SALESMAN, with experience and trade in central States and part of middle west, desires position with first class jewelry or watch house. Address "V., 3207," care Jewelers' Circular-Weekly.

YOUNG MAN, 21, having almost five years' experience with diamond importing house, desires to make a change; can furnish best of references. "R., 2906," care Jewelers' Circular-Weekly.

FIRST CLASS watch repairer, 20 years' experience; Swiss, English and complicated watches are not difficult; references and samples. Address "Watchmaker," 231 W. 22d St., New York.

WATCHMAKER, 33, 18 years' experience, three years in Germany, speaks German fluently, A1 references, best habits, wants permanent position west of Missouri. J. J. Weigmann, Durango, Colo.

RETAIL SALESMAN, with 12 years' experience, desires position with an A1 New York City store; thoroughly understands the business; married. Address "M. W., 3269," care Jewelers' Circular-Weekly.

YOUNG MAN, 18, desires position as stock or shipping clerk in jewelry house; wholesale preferred; 2½ years' experience; first class references. "E., 3193," care Jewelers' Circular-Weekly.

WANTED, manufacturer's line of gold or filled jewelry for retail trade in western Pennsylvania and Ohio, by experienced traveler; salary or commission. Address "E., 3242," care Jewelers' Circular-Weekly.

WATCHMAKER, 27 years' experience, desires position with house that can furnish me 2,000 watches a year to repair; salary, \$25 per week. "Trade Watchmaker, 3194," care Jewelers' Circular-Weekly.

FIRST CLASS watchmaker, 14 years' experience, competent on railroad and finest watches, also fair engraver and jeweler, would like permanent position; best references. "M., 3205," care Jewelers' Circular-Weekly.

A YOUNG MAN of 24, good engraver and salesman, also clock repairer, wishes to make a change; can furnish best of references and sample of engraving. Address "N., 3151," care Jewelers' Circular-Weekly.

SALESMAN wants to represent manufacturer's line of 10-karat or 14-karat gold jewelry in New York City and vicinity; well acquainted with jewelry trade. Address "A. L., 3233," care Jewelers' Circular-Weekly.

MANUFACTURER'S LINE wanted for jobbing, department store and large retail trade on commission for New York City, Baltimore, Washington and Pennsylvania. Address Room 47, 53 Maiden Lane, New York.

FIRST CLASS manufacturing jeweler of fine diamond mountings, having thorough experience of all kinds of jobbing, repairing and setting, wishes position. Address "L. C., 3272," care Jewelers' Circular-Weekly.

SALESMAN, calling on New York City and out-of-town trade, desires change with A1 jobbing or manufacturing house; seven years' experience; highest references. Address "R., 3021," care Jewelers' Circular-Weekly.

WANTED, manufacturer's line of filled jewelry, silver or plated toilet or flat ware on commission; established trade in New York, Philadelphia, Baltimore and middle west. Erle R. Sheppard, 53 Maiden Lane, New York.

BRIGHT, energetic young man, 23, desires position with wholesale jewelry firm, either as salesman or stock clerk; four years' retail experience; A1 reference. Address "Energetic, 3222," care Jewelers' Circular-Weekly.

ENGRAVER, A1, now head engraver for highest class jewelry firm in Pittsburg, Pa., wishes to make a change; distance no objection; married; total abstainer; best references. "S., 3211," care Jewelers' Circular-Weekly.

REFRACTIONIST and watchmaker of ability; expert in retinoscopy, practical adjuster and mounter; good salesman to locate with good house south or middle south. Address "Z., 2779," care Jewelers' Circular-Weekly.

EXPERIENCED watch material fitter; eight years' training; thorough knowledge of Swiss and American watches, also knowledge of jewelry supplies; New York City or out-of-town. "Nemo, 3249," care Jewelers' Circular-Weekly.

A YOUNG MAN, 18, wants situation in manufacturing jewelry concern as clerk; understands thoroughly the making of jewelry; highest testimonials as to character and ability. Address "G., 3256," care Jewelers' Circular-Weekly.

BOOKKEEPER, cashier and office manager is open for engagement; 15 years' experience; thoroughly competent in all details; knowledge of factory payrolls; A1 references. Address "B., 3238," care Jewelers' Circular-Weekly.

POSITION WANTED by an A1 salesman for high class retail store; diamonds, watches, jewelry, etc.; 20 years' experience; honest, reliable and trustworthy; references upon application. "Honest, 3270," care Jewelers' Circular-Weekly.

VERY EXPERIENCED designer and modeler, with own ideas, original and artistic, able to manage the production of highest class jewelry, wants engagement with best firm only. Address "K., 3150," care Jewelers' Circular-Weekly.

A FIRST CLASS watchmaker, 25 years' experience on high grade American and Swiss watches, wishes a steady position; can start at once in vicinity of New York City. Address "K., 3228," care Jewelers' Circular-Weekly.

DESIGNER; first class jewelry designer on gold and platinum work, capable of carving and chasing; also modeling, wishes permanent position; can furnish reference and designs. "J. A. B.," 822 Montgomery Ave., Newark, N. J.

EXPERT watch and chronometer maker, graduate of Glashutte School, Saxony, age 40 years, 20 years' experience, knowledge of light jewelry repairing, optics, etc., A1 references, open for engagement April or May with first class firm. Address "Expert, 3203," care Jewelers' Circular-Weekly.

SITUATIONS WANTED.—Continued

FIRST CLASS watchmaker, 29 years old, 15 years' experience, fast and reliable workman on German, Swiss, French and complicated watches, desires permanent position; speaks German and French. Schneider, 310 W. 28th St., New York.

ENGRAVER, young man, desires position with first class jewelry engraver or an opportunity to learn watchwork in retail store; good script letterer; A1 reference; south or west preferred. Address "J., 3220," care Jewelers' Circular-Weekly.

WANTED; young man wants position as traveling salesman for manufacturer or jobber; Chicago or western house preferred; 12 years' experience in jewelry business. Address "Y., 3120," care Jewelers' Circular-Weekly, 103 State St., Chicago, Ill.

ENGRAVER, A1, all around man on jewelry and silverware, also expert steel and copper plate man, who practically understands plate printing and stamping, open for permanent position after Feb. 7; will go anywhere. Alex. Steele, 299 Sussex Ave., Newark, N. J.

ENGRAVER; young man, good engraver, buffer and salesman, who has done some hard soldering and clock work and is willing to be generally useful around store and shop, would like position with reliable firm; best references. Address "B., 3195," care Jewelers' Circular-Weekly.

A THOROUGHLY competent, practical watchmaker, jeweler and engraver, with more than 30 years' experience, desires position in a northern State after March 15, 1908; own bench and complete outfit of tools; \$25 per week and permanent place. Address "X., 2973," care Jewelers' Circular-Weekly.

PRACTICAL WATCHMAKER of considerable experience, desires a position as missionary for a movement or case manufacturer. Address, "R., 3236," care Jewelers' Circular-Weekly.

SALESMAN or manager, young man, with long experience, highest recommendations, in silverware and jewelry lines, familiar with jobbing, retail and department store trade, qualified to manage branch office, open for engagement with manufacturer of standing. Address "D., 3275," care Jewelers' Circular-Weekly.

YOUNG MAN, 25, with experience as retail jewelry salesman, has just finished horological course of watch work and engraving, desires position under good watchmaker and engraver by March 1; salary, \$15 a week; have own tools. "C. J. H.," Philadelphia Horological College, Broad and Somerset Sts., Philadelphia, Pa.

WATCHMAKER and salesman, 15 years' experience, competent to take full charge, taking in and delivering work, accustomed to railroad work and fine trade, familiar with railroad inspection service; only permanent and first class position will be considered. Address "Vanguard, 3267," care Jewelers' Circular-Weekly.

A COMPETENT watchmaker desires a position: high grade workman; conversant with railroad and fine foreign work; good appearance; can estimate on and deliver work and handle with skill and courtesy all classes of customers; highest references; salary, \$28 to \$30 per week. Address "T., 3245," care Jewelers' Circular-Weekly.

COMPETENT, reliable man desires to travel east or west from New York City with any desirable line; correspondence confidential. Address, "U., 3237," care Jewelers' Circular-Weekly.

Help Wanted.

WANTED, thoroughly competent clock repairer; state salary and references. T. & E. Dickinson & Co., Buffalo, N. Y.

WANTED, at once, first class manufacturing jeweler; good salary, steady position; give references. Tobin & Canham, Springfield, Ill.

WANTED, an experienced workman, who can do good watch work and nice engraving; good salary. Address "Jeweler, 3063," care Jewelers' Circular-Weekly.

WANTED, first class watchmaker and jeweler; permanent position; state references, wages, etc., in first letter. Address "S., 3137," care Jewelers' Circular-Weekly.

WANTED, first class watchmaker and optician; permanent position to right party; state wages desired, references, etc. Address H. Mahler's Sons, Raleigh, N. C.

DIAMOND SETTER, first class, all around man; steady position and good wages to right man; reference required. Address Herman E. Promnitz, 419 Vine St., Cincinnati, O.

WANTED, first class jeweler, who is an all around workman in both new and repair work and stone setting; permanent position; state references, wages, etc. Address H. Mahler's Sons, Raleigh, N. C.

GOOD ENGRAVER and jeweler wanted, at once; permanent position; one who can do some watch and clock repairs preferred; Georgia city of 20,000 population. "A., 3204," care Jewelers' Circular-Weekly.

WATCHMAKER, jeweler and plain engraver; state reference, experience and salary wanted; permanent position; it's 40 miles from New York City, on the water. Address "Z., 3109," care Jewelers' Circular-Weekly.

THREE thoroughly competent watch salesmen, for high class New York retail store; must have good appearance and first class reference; state full particulars and salary wanted. Address Box 3200, care Jewelers' Circular-Weekly.

FIRST CLASS salesman wanted to carry a side line of combs to the retail trade direct from the manufacturer, on a commission basis; only a first class man will be considered; answer with references. "F., 3265," care Jewelers' Circular-Weekly.

WANTED, salesman visiting the jobbing trade in New York City regularly, to carry a small but staple and salable side line on commission; only a persistent hustler with good references need apply. Address "Reliable, 3125," care Jewelers' Circular-Weekly.

A1 general watch, clock and jewelry repairer and good engraver, willing to wait on trade in case of emergency; eastern town of 10,000; good salary and permanent position to right man; single, age 22 to 35 preferred; cigarette smokers and moderate drinkers don't apply. Write "N. E. B., 3140," care Jewelers' Circular-Weekly.

WATCHMAKER and jewelry repairer who can translate from French and German into English, and who knows something about the theory of horology, will be offered desirable position; state age, nationality, education, general qualifications, etc. "R. J., 2314," care Jewelers' Circular-Weekly.

WANTED, reliable person or firm to carry high class line of sterling silver flat and hollow ware in the west from Denver to the coast on commission basis; business already established and only such as have personal acquaintance with the trade need apply; line can be carried in conjunction with first class gold jewelry or kindred line. Address with references, "H., 3266," care Jewelers' Circular-Weekly.

WANTED, experienced jewelry salesman who has made a specialty of gold brooches and scarf pins, to handle a manufacturer's line to the jobbing trade; an excellent opportunity is offered to one who is thoroughly familiar with this line and can command trade; parties not having such experience need not apply. Box 3101, care Jewelers' Circular-Weekly.

Side Lines Wanted.

REPRESENTATIVE wants to represent first class jewelry manufacturing firm at Edinburgh, Scotland and London, England; first class Providence, R. I., reference. Address "S. D.," 231 W. 120th St., New York.

WANTED, a side line from a manufacturer or importer on commission or salary to represent Philadelphia, Baltimore and Pennsylvania towns; best of reference. Address "Hustler, 3160," care Jewelers' Circular-Weekly.

Business Opportunities.

FOR SALE, cheap, a small jewelry shop with Marvin safe; fine location. R. Schaefer, 14-16 John St., New York.

\$2,500 WILL BUY stock and fixtures of modern jewelry store in manufacturing town of 14,000 inhabitants in Ohio. Address "Good Opportunity, 3126," care Jewelers' Circular-Weekly.

\$5,000 WILL BUY jewelry store, averaging \$13,000 cash sales per year; clean stock; good run of bench work; central west. Address "Z., 3215," care Jewelers' Circular-Weekly.

WILL PURCHASE, for spot cash, jewelry, silverware, clocks, etc., also jewelry and silverware lined boxes new or second hand. Sterling Jewelry Co., 54 W. 34th St., New York.

I OWN the most profitable patent on a watch and clock novelty; would like to meet business man with money willing to take partnership in the manufacture. A. Emanuel, 703 Lorimer St., Brooklyn, N. Y.

FINE BUSINESS for sale owing to ill health; will sell at very low price; done a very heavy business this Christmas; price, \$7,000; will rent store also. W. H. Van Keuren, 367 Main St., Poughkeepsie, N. Y.

A FIRST CLASS, well conducted jewelry store for sale, on account of desiring to retire; cheap running lease; will reduce stock to \$3,000; entire fixtures and lease, \$1,000. Address M. Hodes, 2168 Third Ave., New York.

PARTNER; have full control of a patented novelty, a money maker, now being marketed, a good seller, no competition; capital required to extend sales to larger proportions; a clean proposition; only parties of means need reply. Address "L., 3259," care Jewelers' Circular-Weekly.

JEWELRY, optical and musical business, central Kansas, rich county seat town of 2,000; no competition in music line; stock and fixtures, \$4,000 to \$4,500; net profits 1907, \$3,800; new fixtures last October; ill health cause of selling. Address "J. R., 3224," care Jewelers' Circular-Weekly.

FOR SALE, a complete jewelry factory, formerly Eisler & Laubheim's shop, at 87 Maiden Lane; large and light; modern machinery, models, dies, safes and fixtures; includes lease; all at very reasonable price; splendid opportunity. "A. S.," Room 55, 65 Nassau St., New York.

MANUFACTURING jewelry and silversmith's business, large quantity of souvenir spoon dies, drops, presses, roller and lathes, thoroughly equipped and well established trade throughout the west and south, especially California; entire plant and good will, \$5,000. "Particulars," Box 629, Denver, Colo.

WANTED, man experienced in the material business, who has some capital to invest, to join me in a high class jobbing business to be established at a point of unusual opportunity; communications to give full information and will be confidential; references exchanged. Address "I., 3274," care Jewelers' Circular-Weekly.

FOR SALE, one of the best paying jewelry stores in eastern Ohio manufacturing town of 25,000 population, with payroll of \$300,000; fine up-to-date stock and fixtures; invoice, \$16,000; sell for \$14,000 cash; established 23 years; owner wishes to retire; five-year lease on room; don't answer unless you mean business. Address "X. Y. Z., 3206," care Jewelers' Circular-Weekly.

AT 50 CENTS on the dollar and less, corals, jets, ambers, plated and gold filled jewelry, solid gold baby pins, chains, etc., also a lot of diamond jewelry bought at trade auction sales; sent on memo. bills to well rated jewelers; sold for cash only. Address Dan I. Murray, broker and leading auctioneer of America, 3 Maiden Lane, New York.

PARTNER WANTED, practical man to buy interest in one of the best paying jewelry stores in central Indiana; great opportunity; population 30,000. Address, Herman & Loeb, Cincinnati, Ohio.

WANTED TO SELL, at once, a good old jewelry business in a splendid old southern town of about 6,000 inhabitants, with fine agricultural country surrounding it; a grand opportunity for a man who is an all around workman; only those who mean business and have at least \$5,000 need apply; the best of reasons for selling. For particulars address "A Rare Chance, 3170," care Jewelers' Circular-Weekly.

(Special Notices continued on page 184.)

Recently Published

Gems and Precious Stones

Their Characteristics, Localities of Production
Tests and Some Current Literature

Cloth, Postpaid, \$1.00

Published by
THE JEWELERS' CIRCULAR PUB. CO.
11 John Street, New YorkLEARN
JEWELERS
ENGRAVING

"The Engraving School that Graduates Experts."
A fascinating, high-salaried and easily learned trade, taught thoroughly and practically by correspondence. Your instructor is the foremost authority and master workman in the world. We will teach the beginner better engraving by correspondence than he can gain in years of rigid apprenticeship. We will improve the skill of any engraver one hundred per cent, and make him master of the trade. The demand for competent engravers far exceeds the supply. Send for handsome, illustrated prospectus.

PAGE-DAVIS COMPANY,
Suite 10, 90 Wabash Avenue, CHICAGO.

Special Notices.

(Continued from page 183.)

BUSINESS OPPORTUNITIES
Continued.

OLD ESTABLISHED jewelry business, 22 years, for sale, cheap for cash; first class trade and repairing; Christmas trade runs to \$4,000; retiring on account of old age; three years' lease. A. D. Ernne, 21 Colonial Arcade, Cleveland, O.

FOR SALE, well established jewelry and optical business in town of 6,000 in new State of Oklahoma; county seat and mining town; monthly payroll, \$80,000; does \$6,000 cash business per year; nice clean, up-to-date stock of \$6,000; can be reduced to suit purchaser; reason for selling explained on request; don't let this chance go by. Address "D., 3210," care Jewelers' Circular-Weekly.

FOR SALE, jewelry store, established seven years, located in Los Angeles, Cal.; a rare opportunity for a good watchmaker to step right into a good paying business; this store has a fine reputation and enjoying a high class trade; reason for selling, poor health and the doctor advises to quit; only about \$1,500 required; fullest investigation urged. Address "Suburb, 3226," care Jewelers' Circular-Weekly.

CASH PAID for entire jewelry stores and stocks; send us your surplus stock and we will send you a check by return mail; if our offer is unsatisfactory we return your goods; we act quickly and strictly confidential. Jos. Brown & Co., Fifth Ave. and Madison St., Chicago, Ill.

FOR SALE, in the modern "Garden of Eden," southern California, an excellent jewelry and optical business in a city of 8,000 population in the best orange growing district in southern California, a city of wealth and culture; the business has been established over 12 years; good watch repair trade and very fine optical business (dark room with everything complete), cut glass and china room (with separate window for display of these goods, three windows in all for display); complete stock will invoice about \$15,000; can be reduced considerably if desired; must have cash or bankable paper; full information given to all consistent inquiries. Address "California, 3191," care Jewelers' Circular-Weekly.

DO YOU WISH TO RETIRE? Why not turn your entire store or surplus stock into cash? We pay the highest prices, also advance liberal cash amounts on stocks; communicate with us before consulting others; we act quick and strictly confidential. Brooklyn Purchasing Syndicate, 608 Broadway, Brooklyn, N. Y., Telephone, 2328 Williamsburg.

CHANGE YOUR LOCATION and bring your own stock; would you change your location; \$17,000 business in 1907, one that you can move your present stock into and step into a new store room with a business already built making money in an Iowa town? If you have an \$8,000 stock or over correspond with us; if not, don't reply, as your stock would not take the place and be the leading firm; the store is in the best location; the best optical, jewelry and music business in the county; we want to rent building, sell material and part of fixtures; reduce stock to suit purchaser; answer quick. Address Mrs. J. Moir, cor. Moss and Barker Aves., Peoria, Ill.

For Sale.

LARGE MOSLER SAFE, fire and burglar proof, outside and inside double doors, about 3½ years in use, cost \$800, will sell for \$400 cash. Robins & Miller, Syracuse, N. Y.

To Let.

FOR RENT, desk room, with all conveniences, in desirable front office. C. H. Cooke Co., 9 Maiden Lane, New York.

DESK ROOM and bench room, including bench for engraver in fine light place. Stern Bros., 51 Maiden Lane, New York.

DESK ROOM to let in Bennett Building. Apply Room 600, 93-99 Nassau St., New York.

FIREPROOF LOFTS, reinforced concrete building, eight minutes from Maiden Lane, 150 feet from subway station, 41 x 95; elevator and heat. Address owner, Van Nostrand, 118 Chambers St., New York.

FOR RENT, repair shop in New York City for jobbing jeweler; dynamo and complete fixtures already installed; excellent location and good opportunity for practical man. "Repair, 3111," care Jewelers' Circular-Weekly.

TWO large, light, outside rooms in Reed & Barton Building, 320 Fifth Ave., apply H. F. Taylor, Room 302, 320 Fifth Ave., New York.

Wanted to Purchase.

WANTED, a modern large size diamond scale, glass enclosed; must be in good condition; send particulars and price. Address "N., 3196," care Jewelers' Circular-Weekly.

Legal Notice.

NOTICE OF DISSOLUTION OF PARTNERSHIP.—Notice is hereby given that the partnership heretofore subsisting between I. Harrison and S. L. Harrison, under the firm name of the Arsenal Installment Co., at 43 State St., Detroit, Mich., was dissolved on the first day of January, 1908, by mutual consent. All debts owing to said partnership are receivable by said S. L. Harrison, to whom also all claims and demands against the same are to be presented for payment; said S. L. Harrison will continue to do business at the same place. (Signed) S. L. HARRISON, I. HARRISON.

1908 The Year for Coral

Largest Importers of Coral Cameos,
Pears, Beads, Etc., Shell Cameos.Inquiries Solicited from
Manufacturers of Jewelry.Jade, Amazonite, Lapis, Coral, Topaz,
Amethyst, Aventurine, Our Specialty.

VAN DUSEN & STOKES CO.

1123 Chestnut Street

PHILADELPHIA, PA.

HERMAN KOHLBUSCH, Sr.,

ESTABLISHED 1859.

Manufacturer of Fine Balances and Weights

for every purpose where accuracy is required.

Office and Salesroom, 194 BROADWAY, NEW YORK.

Send for Price List.

Tel. 370 Cortlandt.

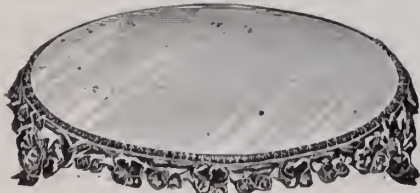
An Improved Line of Mirror Plateaux and Trays.
New and Up-to-date in Styles and Finishes.

JOHN E. ROHRBECK, Manufacturer, 40 Fulton St., New York.

REPRESENTED BY

GEO. T. JACKSON, 839 Market St., Philadelphia, Pa.
DORRANCE BATTIN CO., Chronicle Bldg., San Francisco, Cal.P. HANLEY, 597 Washington St., Boston, Mass.
YARWOOD & HERBERT, 55 Park Place, N.Y.

"Full of Years and Honors"



* V. & C. *

Vacheron & Constantin Watches

have been recognized as standard for 122 years, during which time they have made records for efficiency, captured prizes against all competitors for accuracy and reliability, and gained a reputation among the trade and the general public which is not equaled by that of any other watch in the world. Their remarkable salability is due to these facts.

The public recognition of superior quality is the best advertisement which any article can have, and the high reputation of Vacheron & Constantin Watches is a continuous source of profit to every dealer who sells them.

The line embraces every variety of adjusted watches, complicated watches, extra flat, ultra flat and enameled, carved and jeweled watches.

Edmond E. Robert

SOLE AGENT

3 Maiden Lane, New York



35, Maiden Lane
New York



Most Complete Line of Holders

Now on the Market

Write for Catalogue and Prices

MANAGER AND SALES AGENT
New York Office for

Middletown Silver Co.
Corning Cut Glass Co.
O. F. Eggington Co. (Cut Glass)
Also Rogers Silver Plated Ware



H. J. HOOPER

New York's Leading
Jewelry Auctioneer

Recognized by the Wholesale Houses
the Press and his Patrons

WRITE

him for testimonials that cannot be equaled by any auctioneer in New York.

Correspondence is strictly between the principals. Your confidence has every honorable consideration.

**37 MAIDEN LANE,
NEW YORK CITY.**



JOHN F. TURNER

EXPERT

Jewelry Auctioneer

**2 MAIDEN LANE
NEW YORK, N. Y.**

For twenty-five years I have conducted most all the large jewelry auction sales from New York City to San Francisco, Cal., and have to my credit the greatest number of sales with the largest percentage of profits. I can sell all your undesirable goods, and will guarantee a satisfactory profit above all expenses of the sale.

Nothing Succeeds Like Success

Have just closed a most successful sale

FOR

J. D. Leys and C. F. Christie

OF BUTTE, MONTANA

WRITE THEM FOR REFERENCE

I GUARANTEE
SATISFACTION
OR NO PAY



IF YOU WISH
OTHER REFER-
ENCES WRITE
ME :: :: ::

A. E. GATES

No. 1 MAIDEN LANE

NEW YORK CITY

All communications strictly confidential.

Wire me for open time at my expense.



C. F. RUMPP & SONS

Established 1850
Incorporated 1904

MANUFACTURERS OF

Fancy Leather Ware



THERMOS BOTTLE CASES

- PHOTO FRAMES
- MUSIC ROLLS
- CIGAR CASES
- DRESSING CASES
- STATIONERY SETS
- TRAVELERS' COAT HANGERS
- POCKET FLASKS
- ETC., ETC.



LADIES' HANDBAGS

Fifth and Cherry Streets, PHILADELPHIA

NEW YORK SALESROOMS, 683 and 685 BROADWAY

- LA VALLIERES
- FESTOONS
- BROOCHES
- BELT PINS
- EARRINGS
- BUCKLES
- HAT PINS
- JET

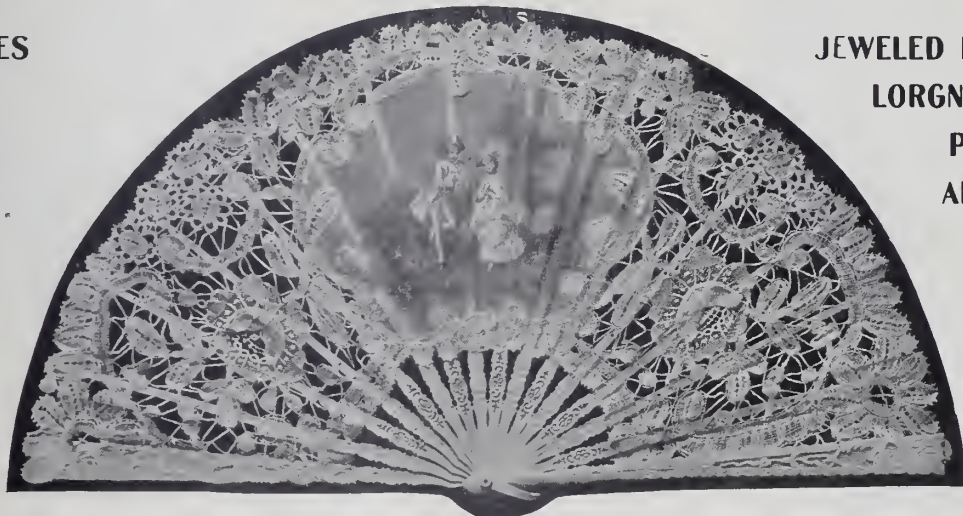

- JEWELED NECK SLIDES
- LORGNETTE CHAINS
- PEARL NECKS
- AMBER NECKS
- NECKLACES
- COLLARS
- ETC.

FANS

AND

IMPORTED JEWELRY NOVELTIES

Mounted with Semi-Precious and Imitation Stones

CAMEOS, CORALS, PEARLS, AMBER, ETC.

Send for Selection, mentioning prices

LEWY & COHEN, Importers, 530 Broadway, New York

DAN I. MURRAY

ESTABLISHED 1880

America's Recognized Leading Art and Jewelry Auctioneer!

ONE HUNDRED CENTS on the dollar guaranteed on any sale conducted by myself or any of my men. I have associated with me three of the best auctioneers in America. You can have the combined efforts of all three at the price of one. Turn your store over to me, I will turn it into cash and hand you the proceeds daily, which will include a satisfactory profit. Note a few of my latest sales, every one at a profit. Most of these fine stocks had been tried by the so-called leading auctioneers who were let out because they could not get anything near cost on diamonds and fine art goods. I took up the same sales three months later and not only sold goods for cost but at a profit. If I cannot give you better results than any of these so-called "leaders" I will make your sale for nothing.



DAN I. MURRAY

Here are a few of my latest sales :

Oliver & Davis, 3 Maiden Lane, New York, six months' sale, daily cash receipts \$600 to \$2,000; Fred F. Mead Co., Syracuse, N. Y., three months' sale, daily cash receipts, \$400 to \$1,500; for Syracuse Trust Co., the Benedict Stock, two months' sale; Chas. L. Becker, Syracuse, N. Y., two and a half months' sale; The Edelhoff Bros. Co.'s stock, 574 Fifth Avenue, New York City, two months' sale; Dodd, Werner & Co., Cincinnati, four months' sale; Stevens, Wallace & Co., Chicago, two months' sale; Caldwell W. Johnson, 1027 Board Walk, Atlantic City, N. J., two and a half months' sale. Total sales for all these different firms, close to \$300,000; my books show a profit over cost to the dealer



H. T. STAPLEFORD
One of my expert assistants, a man with
30 years' experience

of 20 per cent. Remember, Brother Jeweler, these stocks were the finest in America, consisting of 14K. and 18K. solid gold, diamond jewelry, fine art, china, cut glass, etc.; not a brass watch sold by me. Now, if I can do this for these merchants, why can't I do it for you? For over ten years my books have been open to all. I have kept the cost of all goods sold, and I have sold over one million dollars' worth of jewelry at an average profit of 25 per cent. over cost. I defy any auctioneer or pair of auctioneers to show a better or equal record; my charges are no more than the fellow with no ability. Why experiment and ruin your good name by allowing a lot of cheap goods sold?

If you want goods to help the sale along, I will furnish you, on memorandum bill, \$10,000 worth of diamonds, cut glass, watches and everything desired—goods direct from the manufacturers to you—at a price that will enable you to realize handsome profits. Your neighbor cannot compete, as he doesn't buy as I do for cold cash, \$10,000 at a time, if necessary, in order to get the lowest price. Write or wire me at once for dates, as I now have many calls. Write or wire any of the following offices:

3 Maiden Lane, New York

151 Wabash Ave., Chicago, Ill.

512 Race St., Cincinnati, O.

DAN I. MURRAY,

AMERICA'S RECOGNIZED LEADING JEWELRY AUCTIONEER
Recommended by the Press and the Trade.

Solving the Problem

The Trustee in Bankruptcy of the Ayres Stock at Elmira, N.Y.,

tried for six months to dispose of it at retail or in bulk. The best offer received for the stock and fixtures was \$6,600.

We were engaged December 17th to sell the stock at auction.

Two weeks' auction amounted to \$14,900, leaving for the creditors, after new goods used, advertising, commissions, salaries, etc., had been paid, \$10,500 net.

For confirmation of the above facts we respectfully refer to Mr. W. D. Jacobus, Trustee, Elmira, N. Y.; Hon. Roswell R. Moss, Referee in Bankruptcy, Elmira, N. Y.; Mr. Alexander D. Falck, Attorney for The Jewelers' Board of Trade, Elmira, N. Y.; Freudenheim, Levy & Lande, Wholesale Jewelers, Elmira, N. Y.

We always give the exact, and not fictitious, figures of our sales and can furnish documentary proof from those we have served as to the accuracy of our statements.



MITCHELL & TILLOTSON

Jewelers' Auctioneers

35 MAIDEN LANE

- - -

NEW YORK

Mighty Men o' The Hammer



America's Best-Known Auctioneers

HERE IS THE PROOF

No firm of jewelry auctioneers in existence can equal us in the number of sales we have successfully conducted.

Below are a few of our references. We have been supreme in the jewelry auction field for the past eleven years and have never made a failure. We are more than auctioneers; we are business advisers and helpers and can show you how to turn your stock into ready cash in the quickest way. Write for booklet, etc. We advise correspondence for early dates.

REFERENCES

- Geo. W. Winder, Troy, N. Y.
 Chas. W. Crankshaw, Atlanta, Ga.
 Geo. W. Biggs & Co., Pittsburg, Pa.
 A. M. Hill, New Orleans, La., 2 sales.
 Pairpoint Mfg. Co., Chicago.
 A. Stineau, Cincinnati, Ohio.
 Jos. W. Field, Galveston, Texas, 2 sales.
 Roth Importing Co., Denver, Colo.
 Albert Feldenhelmer, Portland, Ore.
 C. E. Buhre, Topeka, Kan.
 H. J. Young, Joliet and Kankakee, Ill., 2 sales.
 Sunner Bros. & Co., Cleveland, O., 4 sales.
 Geo. W. Myers, Meridian, Miss.
 Geo. W. Kennedy, Des Moines, Iowa.
 W. F. Main Co., Iowa City, Iowa.
 S. H. Ives, Detroit, Mich.
 R. E. Samson, Marion, Iowa.
 Oscar Helnze, Quincy, Ill.
 Lange Bros., Dubuque, Iowa.
 George Clark, Lorain, Ohio.
 F. B. Lewis & Co., Cleveland, Ohio.
 P. E. Kearns, El Paso, Texas.
 J. P. Stevens & Bro., Atlanta, Ga.
 G. A. Schlechter, Reading, Pa.
 Slides & Co., Owensboro, Ky.
 C. D. Gardner, Manistee, Mich.
 John B. Miller, Portland, Ore.
 A. Schwane, Beaumont, Texas.
 J. M. Washburn, Celina, Ohio.
 Cutting & Wilson, Winona, Minn.
 W. H. Kelly, Carrollton, Mo.
 W. E. Smith, Bellefontaine, Ohio.
 L. Kaminski, St. Louis and Galveston.
 T. G. Burkhardt, Jefferson City, Mo.
 Fussy & Blair, Missoula, Mont.
 Geo. W. Meyer, Chattanooga, Tenn.
 M. Zimmerman, Jeffersonville, Ind.
 C. W. Ernesting, Gallipolis, Ohio.
 W. A. Kirkham, Leavenworth, Kan.
 Ash & Dembinger, Tacoma, Wash.
 Barnett & Nonnenmacher, Columbus, Ohio.
 A. M. Goldman, Seattle, Wash.
 Lyon & Kylling, Danville, Ill.
 M. Wainch, San Francisco, Cal.
 Woodward, Smith & Randall, Colorado Springs, Colo.
 Wilbur, Lanphear & Co., Galesburg, Ill.
- Harry Harrison, Sanlt Ste. Marie, Mich.
 Sands & Fellows, Cedar Rapids, Iowa.
 Leonard Krower, New Orleans, La.
 W. K. Lippit, Norwich, N. Y.
 W. J. Kelly, Oshkosh, Wis.
 Ritter & Ryan, Muncie, Ind.
 Amos Plank, Pueblo, Colo.
 M. Greer, Iowa City, Iowa.
 J. Albert Schirmer, Saginaw, Mich.
 C. Ettinger, Cleveland, Ohio.
 Rushmer Jewelry Co., Pueblo, Colo.
 Freeman Jewelry Co., Atlanta, Ga., 2 sales.
 Morris Benjamin, Denver, Colo.
 Wm. Beck, Sioux City, Iowa.
 Strow Bros., Fort Dodge, Iowa.
 Sipe & Sigler, Cleveland, Ohio, 5 sales.
 King, Moss & Co., San Francisco, Cal.
 H. Simon, St. Paul, Minn.
 Rodgers & Pottinger, Louisville, Ky.
 Hanna & Eroe, New Castle, Pa.
 D. H. McBride & Co., Akron, Ohio, 3 sales.
 H. Koester & Co., Detroit, Mich., 2 sales.
 H. Kline, Seattle, Wash.
 J. L. Sievert, Springfield, Mo.
 A. W. Ford, Freeport, Ill.
 S. H. Dodge & Son, Ypsilanti, Mich.
 C. F. Baldwin, St. Joseph, Mo.
 David Goldberg, Helena, Mont.
 Dolle Bros., Chicago.
 Bonner Bros., Fort Worth, Texas.
 Hart & Sturgis, Houston, Texas.
 Carlton Jewelry Co., Kenosha and Racine, Wis.
 Stewart & Prescott, Dallas, Texas.
 Parmalee Bros. & Co., Los Angeles, Cal.
 Clemens Hellebush, Cincinnati, Ohio.
 P. H. Lachicotte & Co., Columbia, S. C.
 Harry McIntyre, South McAlester, I. T.
 Duhme Bros., Cincinnati, Ohio.
 Geo. Chantler, Manistique, Mich.
 C. H. Schiller, Utica, N. Y.
 W. H. McKnight, Sons & Co., Louisville Ky., dealers in art furniture, rugs, carpets, &c.
 L. J. Marks, Kansas City, Mo.
 Mermod-Jaccard Jewelry Co., St. Louis, Mo.
 Robbins & Co., Fosteria, Ohio.
 Geo. Nichols, St. Louis, Mich.
 The J. Bolland Jewelry Co., St. Louis, Mo.
- Threadwell, Fort Worth, Texas.
 W. C. Ward, Winchester, Ky.
 Waterhouse, Hamilton, Ohio.
 Larue, Oskaloosa, Iowa.
 Bailey & Co., Ottumwa, Iowa.
 Becker & Lathrop, Syracuse, N. Y.
 W. H. Muller, Denison, Texas.
 Pittsburg Jewelry Co., Pittsburg, Pa.
 J. W. Howard, Hastings, Neb.
 Barnett Jewelry Co., St. Louis, Mo.
 L. R. Shumway, Rockford, Ill.
 P. M. Younglove, Alpena, Mich.
 Alfred Bourgeoise, Jackson, Miss.
 E. L. McDowell, Arkansas City, Kan.
 C. D. Couse, Waverly, Iowa.
 S. Smith & Co., Virginia City, Neb.
 Chas. Taylor, Steubenville, Ohio.
 The Hight & Fairfield Co., Butte, Mont.
 C. D. White & Co., Minneapolis, Minn.
 L. G. Call, Waynesburgh, Pa.
 The Max Rollins stock, Youngstown, O.
 P. L. Lowenthal, Bradford, Pa.
 J. S. Balrd, Watertown, N. Y.
 A. M. Marwede, Alpena, Mich.
 Mrs. Sarah Dickinson Wood, Niagara Falls, N. Y.
 R. D. Worrell, Mexico, Mo.
 Louis Reinheimer, Joplin, Mo.
 Henry C. Briggs Estate, Howell, Mich.
 R. VanKuren & Co., Savannah, Ga.
 A. J. Renki, Augusta, Ga.
 The Sigler Bros. Co., Cleveland, Ohio.
 Margloth & McFarland, Springfield, Ohio.
 W. A. Gill, St. Louis, Mo.
 Burns-Barry Co., Memphis, Tenn.
 The Rogers Jewelry Co., Chicago, Ill.
 Birely & Son, Oshkosh, Wis.
 Morsman Feagan Co., St. Paul, Minn.
 M. Scooler Co., New Orleans, La.
 D. I. Selfert, Beaver Falls, Pa.
 F. C. Cook & Co., Janesville, Wis.
 W. S. P. H., Oelwein, Iowa.
 Mrs. J. H. Havill, Hamilton, Ont.
 L. Luckhardt, Johnstown, Pa.
 Chicago Auction & Commission Co., Chicago.
 More than 100 others, and the jobbers from Maine to California.

WANTED, FOR CASH Entire jewelry stocks, or any part of same, or any amount of the following merchandise:
 Diamonds, Watches, Jewelry, Silverware, Cut Glass, China, Clocks, Bronzes, Opera Glasses, Cutlery, Etc., Etc.

416 Broadway
 New York City

BRIGGS & DODD

5132 Kimbark Ave.
 Chicago, Ill.

*Highest Award at the St. Louis
World's Fair!*



"THE PELTON" ELECTRIC FURNACE

"THE PELTON"
THERMO-ELECTRIC PYROMETER



Patented and manufactured in United States and Canada.

We furnish attachment for using Pyrometer with any Furnace

"The Pelton" Electric Furnace

for Manufacturing Jewelers, Opticians, Enameling, Annealing Glass, and the tempering or hardening of Steel Tools and Dies, has been in actual use the last three years by the U. S. Government Arsenal, Rock Island, Ill.; American Waltham Watch Co., Waltham, Mass.; Mermod, Jaccard & King Jewelry Co., St. Louis, Mo.; R. M. Johnson & Son, Chicago, Ill., and an endless number of jewelry manufacturers in the United States and Europe. Heat controlled from 200 deg. to 2,200 deg. Fahrenheit.

For further information, address

HUGH E. KING, Selling Agt., Room 602, 103 State Street, CHICAGO

One fact already established is the absolute supremacy of The Business Builder

The Business Builder

The Business Builder

Indorsed by the leading wholesale Jewelry houses of Chicago. Write to them in regard to my ability. I can also refer you to hundreds of Jewelers for whom I have made sales. I have just completed a successful sale at Dallas, Texas, and am now selling out the stock of H. L. Morrison, Pittsburg, Kansas. ::: References on request.

The Active, Energetic and Untiring Jewelry Auctioneer



If you want **effective and capable service**, don't overlook the opportunity to write me. Twenty-two years' experience in conducting successful jewelry auction sales justifies me in bringing myself to your notice. In every instance I have conducted sales with profit to jewelers and with satisfaction to their customers. I handle either large or small stocks with equal facility and quickness. I know every detail of the business. Write me for early dates. If necessary I furnish the services of an assistant without extra charge.

Correspondence invited from all parts of the United States and Canada. All Communications treated with the strictest confidence.

No question about it, you're sure to make money if I CONDUCT YOUR SALE.

For quick returns, write to my Chicago Address

M. L. JALONACK

Chicago, 5339 Prairie Ave.—Long Distance 'Phone, Gray 5234

110 East Washington Street, Syracuse, N. Y.

The Business Builder

Advertising Ingersoll Watches

The campaign of Ingersoll advertising for 1908 is planned on broader lines than ever, and is designed more concretely than ever, to direct the public attention to the 60,000 storekeepers of the United States, representing the channel through which the immense number of 12,000 watches daily is being carried to the wearer.

A series of ads. has been designed which fit present business conditions ideally, and in a practical, forcible way, turn the proposition of true optimism to real account—as Ingersoll Watches are not feeling the effect of hard times, if there are any. ¶ These ads. are going into papers aggregating from **25,000,000** to **50,000,000** of readers.

STOREKEEPERS:

Do not fail to take notice of what we are doing, but meet the great demand we are thus creating with open arms, which means, with a full stock, with a good display, and with the name "Ingersoll" somewhere prominently in your store, and especially in your window.

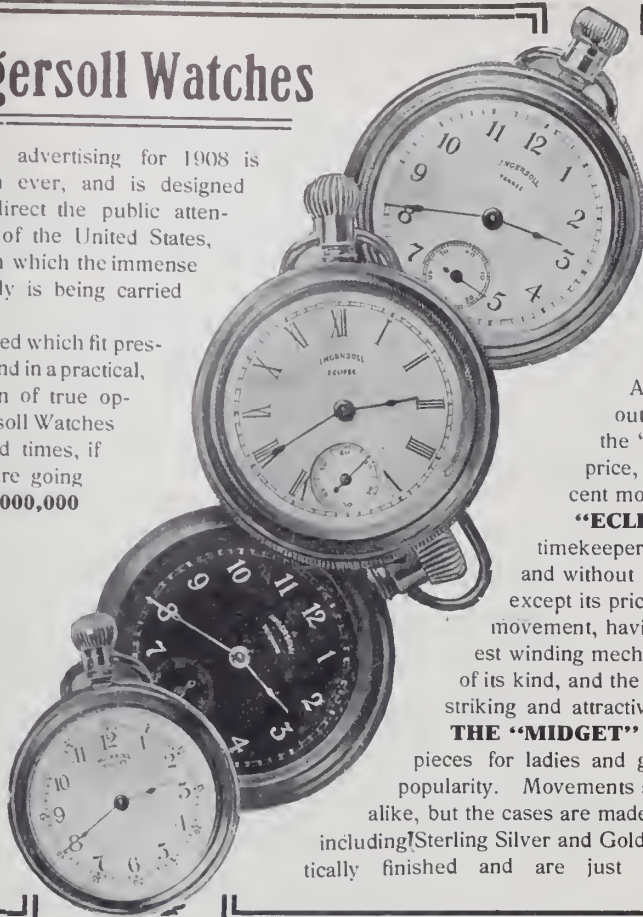

Some 1908 Ingersoll Sellers

"YANKEE." The original and only dollar watch; the watch that everybody is talking about and nearly everybody must be buying, judging from its sales. The present model is full stem-wind and stem-set, like all other Ingersolls, and is smaller and neater than ever.

Although improved both inside and out, and practically doubled in value, the "Yankee" still sells at the same old price, and does not cost the dealer one cent more than it ever did.

"ECLIPSE." A handsome, up-to-date timekeeper, beautifully designed and finished, and without a suggestion of cheapness about it except its price. The watch is fitted with a special movement, having one of the simplest and smoothest winding mechanisms ever adapted to a timepiece of its kind, and the cases are finished in a number of striking and attractive designs.

THE "MIDGET" WATCHES. A line of small timepieces for ladies and girls that rival the Dollar Watch in popularity. Movements are the standard 6 size and are all alike, but the cases are made in a number of styles and finishes including Sterling Silver and Gold Filled cases. They are all artistically finished and are just what the average woman wants.

ESTABLISHED 1887

DUBOIS WATCH CASE CO.



Manufacturers of

Fine Solid Gold Watch Cases



Specialties in Casing of

CHRONOGRAPHS, REPEATERS AND ALL KINDS OF COMPLICATED WATCHES

NEW YORK OFFICE:
21-23 Maiden Lane

FACTORY AND MAIN OFFICE:
316 Herkimer St., Brooklyn, N. Y.

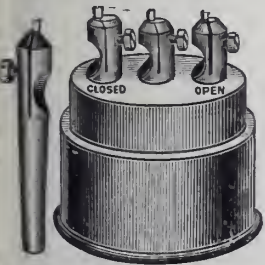

Set of
3 Jewel Setting Cutters
Price, \$3.00

This set will drill 100 and more sizes of holes.
Send for Circular

Culman Tools

Are practical—ask the man who owns them if he wants to do without them at any price.

C. CULMAN

Maplewood - - - St. Louis Co., Mo.

Balance Chuck
Price, \$3.50



Every Chuck or Cutter which becomes worn or broken will be replaced for 25 Cents.

HOROLOGICAL DEPARTMENT
BRADLEY POLYTECHNIC INSTITUTE
Formerly Parsons Horological Institute
PEORIA, ILLINOIS
LARGEST AND BEST WATCH SCHOOL IN AMERICA
We teach Watch Work, Jewelry, Engraving, Clock Work, Optics. Tuition reasonable. Board and rooms near school at moderate rates
Send for Catalog of Information

JOSEPH MEHMERT, Fifth and Race Streets
CINCINNATI, OHIO
GENUINE and RELIABLE WATCH MATERIALS
and everything else from Watch Screws to Diamonds

Mail Orders promptly attended to.

Latest Catalogue in print



WALTHAM JEWEL SERIES WATCHES

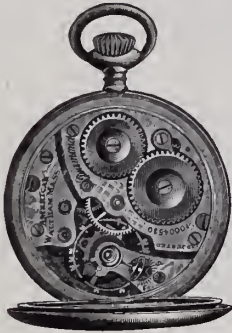

DIAMOND; NICKEL;

17 diamond and ruby jewels; both balance pivots running on diamonds; raised gold settings; steel escape wheel; exposed sapphire pallets; compensating balance, adjusted; meantime screws; patent Breguet hairspring, hardened and tempered in form; patent micrometric regulator; tempered steel safety barrel; gold train; exposed winding wheels.

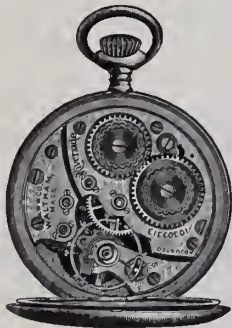

RIVERSIDE; NICKEL;

17 fine ruby jewels; raised gold settings; steel escape wheel; exposed sapphire pallets; compensating balance, adjusted; meantime screws; patent Breguet hairspring, hardened and tempered in form; tempered steel safety barrel; red gold center wheel; exposed winding wheels.

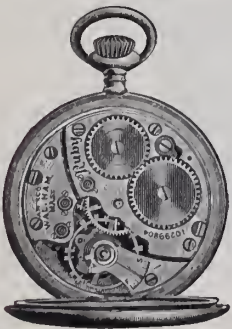

RUBY; NICKEL;

15 jewels; raised settings; exposed pallets; compensating balance; meantime screws; patent Breguet hairspring, hardened and tempered in form; tempered steel safety barrel; exposed winding wheels.

HUNTING OR OPEN FACE

These movements may be obtained in a great variety of Gold Cases, from Plain Polished to the most elaborately Engraved, Carved and Enameled.



Movements Manufactured and Guaranteed by

WALTHAM WATCH COMPANY
WALTHAM, MASS.



THE HOROLOGICAL REVIEW

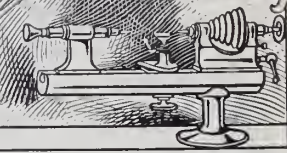

PRACTICAL POINTS ON THE LATHE

Its Manipulation in the Art of Watch Making.
(Written Expressly for THE JEWELERS' CIRCULAR-WEEKLY.)

THE introduction of the American lathe into the manufacturing and repairing of watches dates back to the year 1859. Up to that time, and for a considerable period

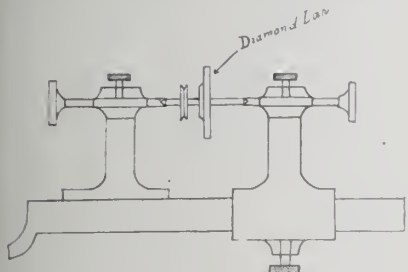

Fig. 1.

thereafter, the German and Swiss lathe with fiddle-bow held sway. These lathes, in principle practically all the same, were as varied in their workmanship as the characteristics of the individual watchmakers, for many took pride in the fact that their tools represented their skill and resourcefulness. We must acknowledge that, with the tools then in existence, considerable skill was necessary in their manipulation, yet their work was of comparatively high grade. Take the lathe represented in Fig. 1, for instance, with diamond lap supported on

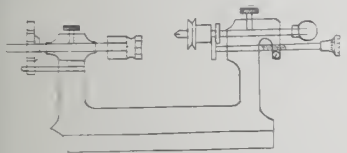

Fig. 2.

centers, used for grinding the backs of pallet stones, etc. Assuredly before one became proficient many stones must have been spoiled for high-grade work. Fig. 2 represents a lathe extensively used, even to-day, for the reduction of train pivots with the burnisher. The advantages of chucking them over such a method is so apparent that further mention is unnecessary. Such lathes, and many others, have given way to American ingenuity.

The advent of the American lathe was heralded by the invention of the spring-chuck with drawing-in spindle. Previous to that time the spring-chuck was made as

in Fig. 3. There was a hole in the lathe spindle corresponding to one in the chuck, but a trifle in advance. The chuck was closed by driving a taper plug through both. The next step forward was the screw compressing chuck. This was modified by the use of a sleeve to secure greater accuracy. Then we come to the use of the drawing-in spindle designed by Starke, et al., 1857, then employed by the firm of Grover & Baker, Boston, manufacturers of sewing machines. These machines met with immediate success, and they could not supply the demand. Their principal drawback was the process of screw making, which was slow and tedious. This department was in charge of John Starke. Necessity drove him to the invention of the hollow drawing-in spindle to enable him to manufacture screws from the rod, as is the present practice. The first drawing-in spindle consisted of a piece of gas pipe with an eight-inch pulley for a handle. This application was made in opposition to his employers' wishes, who insisted that they had no time for experimenting. The absence on a business trip of Mr. Grover furnished Starke with an opportunity to make his spindle, and when Grover returned he saw its advantage. It was not long before he appreciated its value so thoroughly that he cut the price of screw-making almost one-third.

A Mr. White, of the jewelry department in the Waltham Watch Co.'s factory, was the first to make practical use of this spindle and chuck in the manufacturing of watch movements, but Kidder & Adams claim to be the pioneer makers of watchmakers' lathes. Business difficulties and the lathe's unpopularity induced them eventually to sell out to John Starke, the inventor. Starke was a Scotchman with a tenacity of purpose and an undaunted pluck that was admirable, and carried him through many trying circumstances, ultimately bringing him success. He had a machine shop, but most of his force was working on outside jobs—repairing engines, farming implements, etc. With such money as he secured through this means he developed his lathe and spent considerable time doing missionary work among watchmakers. Discouragement was met everywhere. Nearly all of the watchmakers of that period were either

Germans or Englishmen. They had been instructed in tools whose motive power was developed with the fiddle-bow or crank wheel by hand. Prejudice against new machinery was at its height. So, after one of these discouraging journeys, he closed a contract with a large concern dealing in jewelers' supplies and watch materials, to help push his machines. He himself was to do missionary work on the road. It took considerable time before the majority of repairers saw the advantages of these lathes

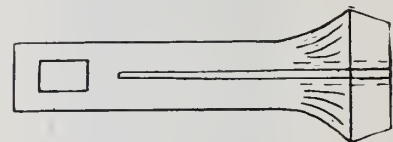
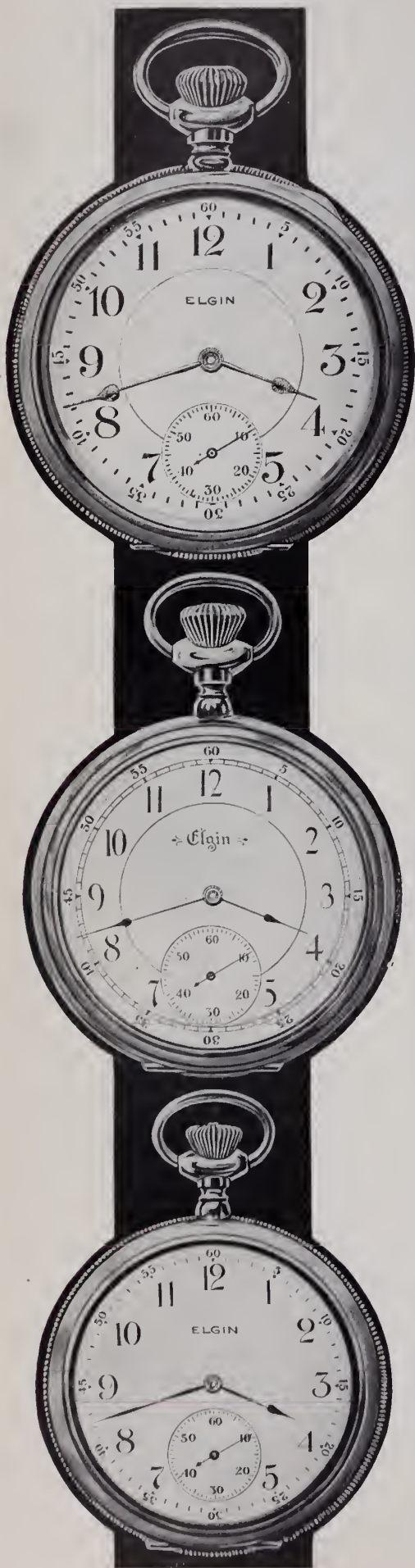

Fig. 3.

and gave them a place in their business. However, before he died Starke had the pleasure of seeing a principle established. A good and successful business was left to his son, and he saw the demand for such tools increase so far that he had to meet the competition of several able makers of watch lathes.

The first lathes made were about six inches long, with a three and a half to four inch swing. Cast iron was used for bearings and unannealed Jessup steel for spindles with conical bearings. This practice has given way to hard spindles and hard bearings, and a design of lathe that is a thing of beauty to the eye and a pleasure to work. The present lathe with its many attachments seems to have reached the pinnacle of development, and serves as a model for English, Swiss and German makers. The latter seem to do the most business in that line. One of the first imitations was that of a German lathe made of brass and nickel plated. It by no means equalled the American lathe in any particular save the nickel plating, and consequently had a limited sale. Now, however, the Germans make lathes which, in design and workmanship, are a close second to ours. When they have flooded the European markets we may expect to see some lathes labeled "Made in Germany," unless a higher tariff schedule comes into effect. However, there is a large demand for tools "made in America" by both Switzerland and Germany. But it is in our accessories that we have, by far, the better tools. In duplicating these they, unfortunately for themselves, selected attachments which the writer considers of faulty design; for all tools reaching unnecessarily beyond their base are faulty. But the German attach-



The G. M. Wheeler Grade

ELGIN WATCH

In 3 Sizes

Popular when it was made only in the 18 size—in great demand now in the thin model 16 and 12 sizes.

Advertised so widely everyone knows of it—priced so reasonably everyone wants it—sells so rapidly every jeweler must have it.

See jobbers list for prices
or write the Company.

*Send for Elgin art booklets,
"Timemakers and Timekeepers" and "The Watch."*

ELGIN NATIONAL WATCH COMPANY,

Factories: Elgin, Ill., U. S. A.
General Offices: 131 Wabash Ave., Chicago.
New York Office: 11 John St.
San Francisco Office: 704 Market St.

ment is not alone in this defect. There is one in particular of American make which has this fault quite pronounced. Of such are all tools that have quite an overhang and operate a considerable distance from their base, like the milling attachments and some wheel-cutting devices. If the cutter

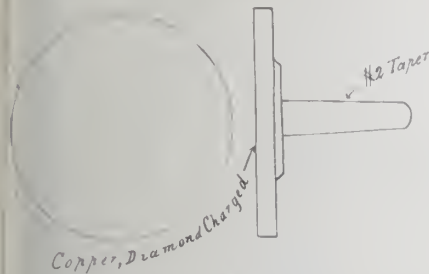

Fig. 4.

is not of the sharpest and the stock easy there is a very perceptible give or spring. In some this is so noticeable that it is dangerous while cutting a train wheel to permit the cutter to revolve on the way back, or you will surely get thin teeth if you do. Rigidity is the keynote of machine design of to-day, and it has become the practice to add metal wherever possible to overcome the slightest vibration; for vibration is in many instances responsible for the dulling of tools long before their time, hereby necessarily giving defective work. This fault—lack of rigidity—is frequently found in combination tools. Couple that fact with the time consumed in putting them into adjustment, and you find some of them are of questionable value. In business time should be regarded as money, and in the equipment of a plant one must select such tools as will give the required product in the shortest time. This frequently necessitates a larger outlay of capital than was at first anticipated, but such process brings returns much quicker than electing a series of defective combination tools. In manufacturing, these combination tools are usually displaced at the earliest opportunity to make way for spe-

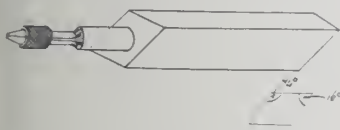

Fig. 5.

cial tools for one particular operation. It is found that too much time is consumed changing over to another operation. This is usually performed by a higher-priced man, and what applies to manufacturing in matters of this kind applies in a measure to jobbing and small duplicating work. This is mentioned because so many tools are bought and then sold at a loss. In buying one is frequently convinced that here is a combination tool covering a range of work which one can buy for so much, while a special tool would cost considerably more.

The writer is not taking a stand against combination tools—far from it—for some of them are very desirable; but he believes the idea has been carried too far. Buying them requires considerable investigation, for time saving and substantiality enter into the matter to such an extent that it becomes a problem.

The lathes of class "A" are of one quality, having hardened bearings and spindles skillfully ground to a seat; for a lathe spindle well stoned to bearing will last years without requiring other attention than oiling.

Watch factories, in high-grade work, prefer to and always do make their own machines when possible. But there are instances when necessity compels them to purchase. In such cases the machines, on entering the factory, are carefully gone over and "retouched" where necessary, for the requirements are fully appreciated. But the small, high-grade watch lathes go to the bench without inspection, and are run for years without repairs. As a rule, they are so well made that the question of trouble does not enter into the buying.

A Convenient Lathe for Repair Work.

As to the lathe best suited for model and repair work the writer finds that a machine measuring two inches from center to bed is a convenient size, small enough to handle quickly and yet large and rigid enough to withstand comparatively heavy usage. With such a lathe and its requisite attachments a watch movement could be built throughout, even to the making of accurate master plates. These plates are made of steel, three-sixteenths of an inch thick, with a diameter as large as an 18-size movement. And it is by the use of these master plates that we, here in America, are enabled to duplicate and reproduce locations down to a very fine measurement. For, no matter how well a tool is constructed, and how nicely the parts are made, it is subject to wear, necessitating repairs, and, by transferring holes and positions from master plates to the tools, one insures a true reproduction of the original model, so that, generations hence, if the same movement were continued its positions would positively be the same as in the original model. In short, they preserve for all time the relation of one part to another. In dealing with a subject of this nature one is apt to go beyond the usages of these tools by the average watchmaker. But the attachments mentioned are those capable of carrying through a watch from start to finish.

The equipment of the head consists of a large index plate with a wide range of holes. These run from 51 to 366, the range covering both sides of the plate. If for quantities of any particular work, requiring divisions, individual indexes are better. The Schneider step-chuck is designed for both internal and external gripping. The brass cement chucks are of various sizes; their use is so familiar to all watchmakers that the writer will merely go into the shellacking of jewel setting here.

The brass should be turned to a small diameter to take heat readily. After heating, place the jewel setting thereon, and with a slender piece of wire, taper pointed so as to go into the hole of the jewel (the machine running at moderately high speed and the wire supported on the rest), you can bring the jewel hole to dead center before it cools. You can then turn it to the desired diameter.

Among the number and sizes of spring chucks—and one cannot have too many of these—there are the diamond lap, the box-wood lap, the cast-iron lap and the India oil-stone. Then there is the indispensable

chuck with large face plate and clamps to do plate work.

The Universal head is deemed necessary by some to perform high-grade work, but the writer considers it a luxury to a watchmaker, as he has made a new model watch movement complete, as well as master plates from same, all in workmanship above criticism.

The writer uses a face plate furnished by the machine maker as large as the machine could conveniently take. The lathe was a first-class one, with throat ground perfectly true, and chuck fitting same nicely. Repeatedly taking the plate from the head and putting it back again, on placing an indicator against it for a test the greatest error found out near the diameter has been .001 metric measurement. The majority of

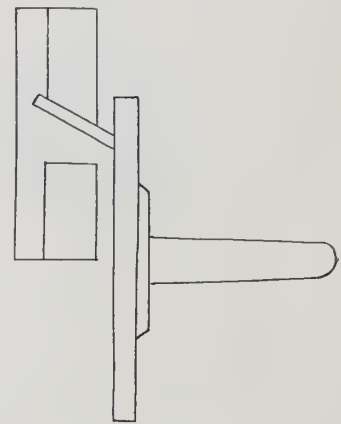

Fig. 6.

times the writer could find practically no error. The patent clamps or jaws are furnished with this face plate. While these jaws are excellent for repair work, the writer would never use them for original work and the making of master plates, for it leaves too many possible chances of error. Dirt between the two surfaces throws the plate on which you are working out of perpendicular. It is always advisable to use the toolmakers' clamps for all face plate work.

In all work of this nature it is essential that the face plate be in poise; otherwise, if you run your machine reasonably fast, it will "throw out" or run out of true. The pump center furnished with this face plate

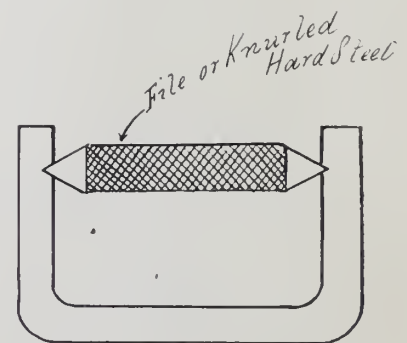

Fig. 7.

is good for repair work, and is used extensively in manufacturing. But for model work it should not be considered an instant, but rely entirely on a sensitive indicator. This face plate is fitted with a pump center, not a taper center.

The diamond lap is made of copper or

Keystone Solid Gold Watch Cases



The Smallest Watch Case Made

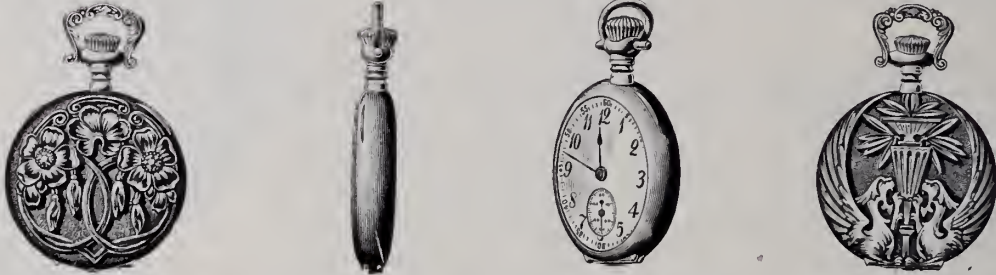

Fitting 10 x 0 Size (Lady Elgin) Movement
Fitting 10 Ligne Waltham Movement

- ☐ Hunting and Open-Face, Bascine, Plain Polish, Satin Finish and Roman, with French Bows.
- ☐ Open-Face Art Nouveau decorations, with and without diamonds. Fancy Art Nouveau Bows.
- ☐ Open-Face in EXCLUSIVE SPECIAL DESIGNS, a large variety of patterns with enameled and relief work, with and without diamonds and other precious stones.

These SPECIAL NOVELTIES are NOT DUPLICATED.

- ☐ Hunting and Open-Face Cases made only in good, substantial weights.
- ☐ Open-Face Cases made only with inside caps, jointed backs and bezels.
- ☐ Open-Face Cases all have swivel pendants.
- ☐ All these cases are Made, Engraved, and Decorated by Special Gold Case Artisans.
- ☐ These are all Cased by the MOVEMENT MAKERS—

THE ELGIN NATIONAL WATCH COMPANY AND
WALTHAM WATCH COMPANY,

with extreme care in order to assure perfect adjustment, and sold to you by your jobber only as complete watches.

KEYSTONE 14 K. SOLID GOLD CASES ASSAY

585-THOUSANDTHS FINE

14 K. GOLD ASSAYS 583 $\frac{1}{8}$ -THOUSANDTHS FINE

Trade-Mark



In back.

Note this Guarantee



In cap.

Look for



This tag.

THE KEYSTONE WATCH CASE CO.

NEW YORK

CHICAGO

PHILADELPHIA

CINCINNATI

SAN FRANCISCO

essener steel—preferably the former, owing to its being a more pliable metal, permitting the particles of diamond to embed themselves more securely than in steel. The method of charging is to have a hardened roll supported on a T-rest and pressed firmly against the lap. Let the lap run slowly. The diamond, mixed with oil, is smeared on the lap. The lap should be about two and one-quarter to three inches in diameter and from one-eighth to three-eighths inch thick, mounted as shown in Fig. 1. Some few watch repairers have the diamond and facilities with which to charge the laps. Those not so favorably situated should send the laps to the factory and have them charged. They should state that it is to be used for the purpose of sharpening small drills, etc. As a means of sharpening small drills it is unequalled. There is not the slightest danger of drawing the temper, and the smallest drills are readily sharpened. One feature to be borne in mind, however, is to avoid crowding the lap while grinding. No harm will result to the work, but the action serves to loosen the diamond particles.

Sharpening Small Drills, Etc.

An excellent and satisfactory method of sharpening small drills is by the use of a block made of boxwood, or any hard wood, as shown in Fig. 5. The block is made oblique. Use two opposite sides for grinding the flats and the other two to give clearance to the lips. The block naturally is supported by the table rest, thus giving one the two flat sides perfectly ground with converging sides. The central pointing is a matter of skill of the individual operator. This is the method employed in watch factories where 100 or more drills are sharpened in a day, except in such cases where they are ground automatically.

To construct Fig. 5, have a block of wood with the pin vise fastened through the center or taper to fit drill chucks. The sides of the block are made 16° and 74° , as shown in engraving. Many other things will suggest themselves to be used in this manner. A block perfectly square will grind the squares on stem work, when they are a trifle large, quicker and better than filing, and a triangular block will grind and sharpen taps more satisfactorily than by hand. It will also make them last longer.

Next in use to the diamond lap for such purposes is the fine India oil-stone mounted as in Fig. 4. It is by no means as satisfactory as the diamond lap. The pores soon clog with dirt and the work consequently becomes heated. To clean and sharpen this stone, rub it on a cast-iron or lead lap with medium coarse emery. Rubbing on a sheet of emery cloth with water serves the same purpose. Another method of grinding is to use a cast-iron lap with loose oil-stone powder. This is an economical means of grinding. Its principal advantage is that it grinds smooth and leaves absolutely no burr.

For such tools as wheel and pinion cutters or master former cutters, where you wish to reproduce a form accurately, sharpening by this means is unequalled. In the factory it is used extensively. All staff turning tools, and others that require a fine edge, are sharpened in this manner. The lap is mounted in the same manner as

in Fig. 4, and is from three inches to three and one-half inches in diameter, and run at a tolerably high speed. The face is roughed by a coarse file to afford lodgment and support for the fine grains of oil-stone. The lines, of course, must be radial—that is to say, from center to circumference. The oil-stone is mixed with oil to the consistency of paste and applied to the lap by a piece of felt, or brush. The amount of oil-stone applied has to be determined by experiment. To those unacquainted with this method the writer would suggest a trial. The powder is to be had at the supply houses for 15 cents per pound for American make and 25 cents per pound for the French. The latter has a superior cutting quality; a single pound will do considerable work.

When we have the boxwood lap turned smooth, fine diamond is smeared on with the finger. This is important for work of high grade, for it is by this method that we sharpen the sapphire cutters used for the stripping of jewel settings, wheel hubs, etc.

For smoothing a roughed, or chipped, pallet stone the following method is excellent: Make a block of steel, or brass, as shown in Fig. 6, having the stone shellacked with impulse face parallel with face of block, but projecting somewhat beyond. This can be determined by placing the block close to the lap while the shellac is heated, the block being parallel thereto. With an eyeglass observe if the impulse face of the



Fig. 8.

stone is parallel with the lap. Any like method which will suggest itself will serve. Take care during polishing that the block is kept parallel to the lap.

Boxwood and diamond are used to great advantage in removing pits from end stones. A neat and effective way of protecting the lap is to fit it into an American Waltham 16s or 18s shipping case. The treatment is to rub the jewel thereon either with the finger or a stick of boxwood. Two laps would be better—one as a rougher, charged with No. 4 diamond, and the other charged with No. 6, as finisher. These are bench laps and are not run in the lathe.

A boxwood lap mounted for lathe, or one made of tin (though the former gives the best effect, being a deep black polish), can be used very effectively on all beveled steel work when rusted or stained. Shellac the work on a long stem and present the face of the bevel to the lap. The other end is located on the bench. In the meantime apply fine powdered lime with a brush. The lime and alcohol should be of the consistency of glue. The quickest way to remove shellac from work is by using common potash— $1\frac{1}{2}$ tablespoonfuls to about a quart of water. The work should be suspended and should not rest on the bottom after bringing the water to boil. One to two minutes will clean thoroughly. It can be used in the same sense as alcohol; allow it to set in cold potash water. This will take perhaps five or six hours. If the work through some means becomes stained

an effective method to remove same is as follows: Boil your potash, *put out the fire*, immerse your work in benzine, and dip quickly into your boiling potash. Allow it to remain in same about five seconds, then wash in water. Soapy water is preferred; then benzine, or preferably alcohol.

To go back to lime: Lump lime should be used in preference to powdered, as there is less likelihood of its becoming slaked. It should be kept in air-tight cans or jars, for quicklime becomes slaked with exposure to air. With a knife, by scraping, you can get a fine powder from the lump. This, mixed with alcohol and applied, is an average good mixture, and under proper conditions will give steel a high polish.

For flat steel work to be polished by hand with a lap on the bench use a mixture of carbolic acid and water—four parts water to one part acid. This, to be used with an equal quantity of alcohol, makes a good average mixture. Sometimes, though, this will give a pitted effect on steel work. In such cases try soapy water with lime and one drop of alcohol. The laps can be either of boxwood or tin. The latter give a flat surface, while the former show a strong tendency to round, as is so noticeable on cheaper movements. For all flat steel work a high grade of metal should be used. Otherwise you get a steel which will not readily harden on the surface. The act of rolling seems to drive the carbon to the center, and it is sometimes best to leave work large, with a generous amount to take off before polishing. Otherwise on poor stock it is next to impossible to secure a high-grade polish.

Use and Abuse of Chucks.

Now, as to the spring chuck: On this subject one can say there are chucks and chucks. While most of them are of high grade, yet none should be purchased unless the manufacturer's reputation is known. The writer repeatedly sees chucks that have "set"—that is, after continued use they closed in. A screw-driver had to be forced in the slots to open the chuck to required size. This resulted in the chuck running out of true. But the best practice of chuck making, as followed by responsible manufacturers, gives a chuck that is good and hard at the gripping taper, and from there on of a spring temper. The holes should be ground true and round with diamond-charged laps. The two abuses to which chucks are subjected, and against which the writer would warn all users, is, first, forcing a piece of wire, or work, which is too large for it, into the chuck. If through accident the chuck has a poor temper (and where is the workman in any department who is not subject to error?) the chuck is apt to set with a back taper. And, *vice versa*, using wire entirely too small for chuck. Second, bringing the drawing-in spindle up tighter than necessary. All chucks are pretty soft on the threaded end, and, if this abuse is continued, you soon have a damaged drawing-in spindle and an impaired chuck. Nothing is so exasperating as a stripped drawing-in spindle, or chuck, for there is no excuse for that condition. Where you imagine extra heavy gripping is necessary it is proof your method is wrong.

Chucks, if properly used, will outlast the life of the average watchmaker, or operator,



16-Size
Thin
Model

EXCELSIOR

THIN-MODEL

WATCHES

possess so many attractive features that every dealer should have a representative line of them. They are just the watch for you to offer to the economical buyer who wants full value for his money. You will have satisfied customers and

WILL GREATLY INCREASE YOUR WATCH SALES

Made especially for the Jewelry Trade in 6, 12, 16 and 18 size.

3 GRADES—ALL SIZES

20-Year Gold Filled—white tags

10-Year Gold Filled—blue tags

Silverode—red tags

A Stock of them is now in the hands of all jobbers.



Three-quarter Plate, Nickel Damaskeened, Nicely Finished Throughout, Specially Timed, 7 Jewels, Quick Train with Bearings in Metal Settings, Cut Expansion Balance, Breguet Hairspring, White Enamel Dial.

Every Watch is STEM WIND and PENDANT SET (excepting the 18 Size Hunting, which is LEVER SET)

All are THIN MODELS
All are "Timed in Case"
at the factory
All sell at "Fixed" prices
Everywhere

If you have mislaid your Trade Booklet, write for another copy NOW

NEW YORK STANDARD WATCH CO.
JERSEY CITY, N. J.

inside or outside of a watch factory. In buying a lathe with chucks that have been in use, it is well to note if this abuse is noticeable.

The patent balance chuck is the quickest and handiest for burnishing and polishing or reducing a pivot. The most serviceable tool for that purpose, and one used in the factories, is the sapphire file, made of a piece of sapphire about three-sixteenths by one-eighth inch, with about three-fourths of an inch extending from the holder. This is roughed by a diamond lap, the lines to run at right angles to the length. After the pivot is reduced to size, smooth with bur-

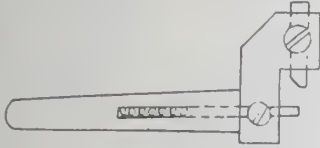

Fig. 9.

nisher. For a high polish use boxwood and lime mixed with alcohol. If lathes are not handy an economical and just as serviceable a tool can be had. A small and inexpensive tool is made for that purpose and used in the finishing and adjusting rooms of factories where there is not sufficient work of that kind to justify installing a lathe. The tool is used with a fiddle-bow, and is obtainable at the supply houses.

There are quite a number of tools for repair men designed for the polishing of balance pivots. All of them, one may say, are perhaps good enough for repairing, but when, in viewing repairing from the standpoint of putting the movement into as good condition as when it left the factory, these tools, or polishers, are not quite the thing. It is utterly impossible to hold a polisher steady with no support save a free hand, and under belt tension you may imagine you are doing so, but it is safe to say the pivot will not be round, and, in the production of pivots, this is quite essential. The best and most convenient method, and the most expeditious, is to have the fixture clamped to the bed and face of the metal polisher parallel with the pivot. Nearly all tools designed for this purpose for repair men show the face of polisher at right angles to pivot. This is for convenience of the fixture to which they are attached, and is supposed to appeal to the economic side.

A perfectly smooth surface, where you have loose material either to polish or grind, is wrong on principle; so with these bell metal polishers the face and rounded corner are pitted for lodgment of rouge by a tool as shown in Fig. 7. To make one of these, anneal a section of a round file about one-fourth inch in diameter and one-half inch long and turn the pivots on end. But before doing so protect the file and chuck by wrapping paper around it to hold in the chuck. Next harden. The holder is merely a piece of brass with holes drilled through and sprung together.

An excellent and satisfactory scheme for polishing a staff and getting right up into the corners is to use a piece of brass with rouge, as shown in Fig. 8. The rounded edge with clearance and sharp corners will readily appeal to the understanding of the watchmaker. A wigwag undoubtedly would

be better, but in the absence of one this is quite serviceable.

Slide Rest, Transverse Grinder, etc.

Where the work is of such a scope as to require a slide rest a transverse grinder securable to the slide rest is almost indispensable. The range of work this tool can be made to cover is astonishing—from internal to external grinding; milling in all its forms, recesses, etc.; the raying of winding and ratchet wheels with a cupped emery wheel; the grinding of sapphires for special tools, etc. It is a tolerably rigid tool, producing no jumping of the mills to speak of, as is the case when the milling fixture is tacked as an attachment to some other tool. Of course it must be understood that a proper milling fixture, made for that purpose, also to cut wheels and pinions, cannot be equaled, and, in speaking of the above, one must recognize the fact that there is so little call in watch repairing for a bona fide milling attachment that the use of the transverse grinder is suggested in lieu of it.

Let us take its uses on sapphire, presuming you wish to make sapphire ends for your calipers, used in hairspring trueing. Cement your slab in the cement chuck. Use your diamond lap charged on the diameter and grind, as you would with the emery wheel, on a piece of steel, but not quite so heavy a cut, as sapphire is quite brittle. When ground to diameter, use boxwood lap with No. 4 diamond to polish it. It thus becomes transparent. Turn it around and finish the other end. Then niche it with diamond, take it out of the chuck and break. Now put your sapphire in the spring chuck and start an acute center with diamond, and, to bring it down to a fine point for the pivots to rest in, use a piece of soft wire, filed to a point, and loose diamond powder. Do not run the machine very fast while doing the latter, as centrifugal force will throw the diamond powder away from the point. Next use a piece of boxwood with fine diamond to polish. Your own ingenuity, after a little practice, will show you the resourcefulness of this tool. The cotter mill is the easiest mill to make and answers the purpose admirably for milling with this attachment. The swing rest or jeweler's caliper rest works into the combination idea more than any other tool of a watchmaker's outfit. Some are very good and others are ostensibly for the purpose of a business transaction only. For surely with other necessary tools at hand better and quicker methods are at the disposal of the repair man, and when one can afford to have the facilities for doing work expeditiously and well, have them by all means.

One invention is a table rest attached to the swing rest. Since one must have a T-rest, a table rest in some fixture is just as cheap as that furnished with the swing rest and infinitely better. Imagine the vibration and dulling of saws to go with such an unstable foundation. There is such a large overhang, to say nothing of the large amount of metal in the way of properly handling the work. Another device shows a swing rest pushing a drill into a piece of work in the chuck. Nothing is so conducive to irritability as a tool that seems to be in its own way. In this case a tail stock answers the purpose ever so much better, and a tail stock is indispensa-

ble for quick approximate locations for work laid out where the pump center is not available, etc. But the majority of attachments seem to fill a purpose very well, and are to be commended, particularly where they take the place of otherwise expensive tools so seldom used. The swing rest is one of the most resourceful tools in the outfit, and its uses are innumerable. It was primarily and essentially a jewelry tool, but its advantages are such that it has its place in every department of watchmaking. For the making of bushings, opening holes in plates, recesses, and boring of every description it is unequalled. Using a goose neck or spring tool, you can cut a groove or clearance in bridge or plate without the slightest danger of jumping or spoiling the work.

Some few swing rests are graduated to enable one to determine the depth of cut taken, or for the regulation of same. The scheme is good, but 90 per cent. of the swing rests are not graduated. In such cases the following method is just as good, and more accurate. Let us say you wish to cut a recess in a plate to a depth of .085. Bring your cutter right up to the plate, or work. Place a piece of wire .085 in diameter between the stop and screw of swing rest, so that, with the thumb pressed against spindle, the wire is held there firmly, and with head revolving the cutter barely marks the work. Now take away the wire, and you will cut a recess just .085 deep. The sizes of wire ranging from .010 to .100 the writer finds one of the most valuable adjuncts to an outfit, and the wire can be purchased for about one cent a piece. They are useful in finding sizes of holes, depths and measurements. They are extremely useful for making drills and reamers for sizing, for drills as a rule will drill a hole larger than themselves. Hence it is advisable to use a smaller drill and ream them to size, when one desires a hole of a given diameter. A small drill chuck holding all sizes of wire is to be obtained for the purpose of drilling, etc. An excellent cutter holder for duplicating a jewel setting is shown in Fig. 9. Place the old setting in chuck, move cutter up to diameter and

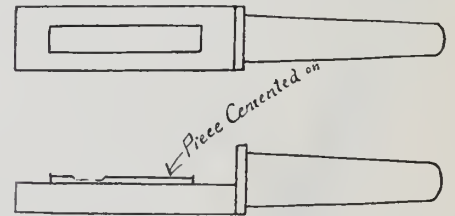

Fig. 10.

shoulder, with center pin to touch face of jewel. Then place in the new setting and cut until center pin touches the face of the jewel. Fig. 10 shows a useful fixture for the grinding of flat springs when too strong. The emery wheel is mounted in the head and the work cemented on the fixture which is held in the spindle of the swing rest. There are other methods, of course, whereby work can be done just as satisfactorily, but the foregoing are suggestions with which perhaps the average watch repairer is not familiar.

The Swing Rest Jewelry Caliper.

The jewelry swing rest was primarily

Ball Watches

THE RAILROAD STANDARD



☞ Reputable dealers will find Ball's Railroad Standard Watches a most attractive business proposition to handle. People are beginning to demand in their watches, the same perfect accuracy that railroad men require, and nothing short of a "Railroad Standard" will prove satisfactory.

☞ The Ball Watch is built for railroad service—strong, durable and accurate. It is adjusted to all conditions of temperature, and to five positions, and made in both 16 and 18 sizes.

☞ We sell reliable dealers only—no mail order houses or department stores. Every Ball "Railroad Standard" Watch goes out cased up complete, in crack timekeeping condition, all ready for your customer's pocket. Sold at an established uniform price that never varies; each one placed means another satisfied customer for you, and fair return on your capital and time invested.

You are interested—write to-day for dealer's proposition.

THE WEBB C. BALL WATCH CO.

BALL BUILDING
CLEVELAND

RAILWAY EXCHANGE
CHICAGO

designed for jewel setting, but its adaptability to such a wide range of work commands the serious attention of all watch-makers.

In this line the endeavor will be made to acquaint those who are strangers to its manifold uses with a few of its principal features. The simplest and most general operation is the boring of holes, the cutting and enlarging of recesses, etc. This is accomplished by the use of a tool and holder



Fig. 11..

shown in Fig. 11. The diameter of the cutter should be in the neighborhood of about 2 metric measurement. That size will handle anything up to barrel recesses and clearance for dials. For holes which are smaller than .250 the cutter can be made to suit, but the same size wire should be used, so that it will fit in the holder. It is advisable to file them to shape while soft, then harden, rather than harden and grind to shape. If the lathe lines up well you can file the wire to the center; that is to say, file away half of its diameter. Then you have a tool that is just right for cutting. If, however, the swing rest does not line up, put wire in holder and file a little at a time until the cutter has the relation as shown in Fig. 12; that is, the top of cutter is on line with center of head. In boring a deep recess care must be exercised as you come into the corners. The tool, you will observe, has more clearance on the end than on the side, which, as it takes hold of the metal, causes it to spring, then dig in, with a possible accident, or it chatters. Hence it is advisable, as you feed out to the diameter, to stop a little short of it. Then bring out to the diameter and feed laterally; that is, traverse your spindle instead of cross feed. Recessing, boring, etc., can be accomplished with the slide rest, but it is by no means as quick and

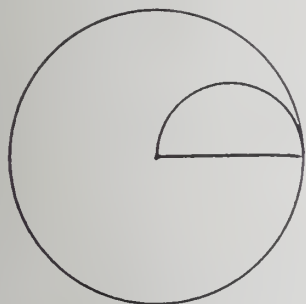

Fig. 12.

satisfactory as a jewelers caliper swing rest. However, before we bore a hole we must, of necessity, drill one. And here is where we find an error that is quite common—namely, in the holding of a twist drill by the small hand vise, as in Fig. 13. This is responsible for so many hurt fingers and marred or spoiled work, for you are gripping on two lines only, and there is a strong temptation for drills to roll. Three points of contact, however, will not only

confine it, but also grip it more firmly. An excellent holder for that purpose and adapted to many other uses is shown in Fig. 14.

If you do not have a tail stock, as is frequently the case, a taper with a generous female center fitted in the spindle of the swing rest will answer the same purpose. But it is necessary that it should be in line with the center of the live head, or very nearly so. In using a twist drill on brass or nickel it is necessary to remove the rake, or front clearance, if you wish to avoid accident when the drill breaks through on the other side. This is accomplished by the use of an oil-stone. Without this rake removed the drill cuts in bunches, and as it breaks through, with no metal to steady and support the point, there are two sections left, which act as a nut and draw the drill in by virtue of the twists acting as a screw. This generally results in a nasty bruise and damaged work. In flat drills this danger is not present.

The swing rest is worked to excellent advantage either in alterations or in new work, in the boring in stem work, such as enlarging the clutch clearance or widening the groove that goes with some watches, etc. This work requires a hook tool as shown in "b" (Fig. 11) held in the holder. Such tools can be made by bending the wire at



Fig. 13.

right angles while hot, and then filing to shape, or they can be turned from a larger wire, as shown in "a" (Fig. 11), and filed away.

Now let us proceed to get the plates into position to do the work. With the angle plate made according to the dimensions shown in Fig. 15, having the sides parallel and square, with faces and the two holes perfectly parallel with the sides, the work is bound to come out right. One hole is used as a pump center to locate the center staff hole, thus locating the plate. The next is a locating pin for the angle plate. An excellent scheme to get these holes to line up perfectly is to make a jig as shown in Fig. 16. The shoulder is held firmly against the side of the angle plate and clamped in the desired location; the holes and pins should be nicely made and fit well; also the V in the locating pin should be perfectly central. This can be done by the use of a milling fixture and index plate. The pin is held in the chuck, which runs fairly true. Now, since the center of the stem hole is the face of the pillar plate, we measure the thickness of the lower plate and double that. This gives us the size to turn the plug (preferably of brass) in the face plate center.

With our tools made we set up as follows: Bring the angle plate right up to the pin (in the center of the face plate) which locates it for height. The locating pin with V locates it sidewise. Now clamp to the face plate. Observe, after clamping, with a glass, if the pin touches both sides of it. As it frequently happens, clamping is apt to

shift, hence the necessity of close observation. Now we place our plate on and locate with pump center. Also bring forward the tail stock with center to assist in locating. Next clamp it in position either with special clamps or common C-clamps. All that is necessary to make it run perfectly true is to shift the movement on its axis, which is readily done.

If we wish to increase the diameter of hole or recess, say, .030, we bring the cutter



Fig. 14.

right up to the surface we are to remove, and set two gauge fingers, holding it there. Now we start our machine—which, by the way, we find it necessary to counter-poise—and advance the cutter with one of the gauge fingers until we can drop a piece of wire measuring .015 between the other gauge finger and stop. Thus we have enlarged it exactly .030. As to the lateral feed, as in the case of enlarging a clutch clearance, we run the tool up to the forward shoulder and set the stop, the machine not running meanwhile. Then bring it back to the other shoulder, take a cut by advancing the gauge finger and run up to the stop, then continue so until you can drop the .015 wire between the gauge finger and the rest. When you are but cutting a groove, locate the cutter, lock spindle, and advance, using the wire as gauge for depth.

To open an escape or train wheel to fit them on pinion we proceed as follows: Open a cement chuck to the diameter wheel and cement the wheel thereupon. The chuck is heated in the lathe, which will insure its staying true. Most wheels for jobbing, as they come from the factory, true with the hole, and a broach is all that is necessary to open them to size. But there are many instances where a considerable amount of metal has to be removed. In such cases the use of a cement chuck is advisable, particularly with escape wheels, as these should, by all means, run true on the diameter. An excellent tool for this purpose is a drill chuck made on a No. 1 taper as illustrated in Fig. 7. As the tool wears or breaks away the collar is driven off, the wire pulled and fastened, then sharpened as in Fig. 11.

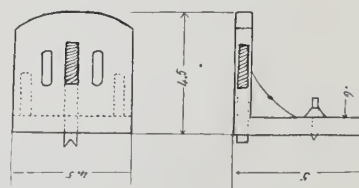

Fig. 15.

This tool, of course, is to be used in the jewelers' swing rest. It is found very serviceable in opening holes for bushing when they have worn too large for the train pivots, etc.

The system of rubbing, in jewels, both in the setting and in plates or bridges, is, of necessity, different in the factory and jobbing house from that used at the repairer's bench. In the factory we rough out the setting on automatic machines as illustrated

New England

WATCHES

THE BEST VALUE WATCHES MADE

The popularity of *New England* Watches is well illustrated in the statements from representative jewelers published in the January issue of THE KEYSTONE.

From all parts of the country the reports are practically the same—"Medium-priced watches are in greatest demand; the more expensive ones move slowly."

Medium-priced watches mean *New England* Watches. They are the kind the public is buying, and the public is pretty sure to buy the best to be had for the money.

Here is a pointer for you, Mr. Dealer. Stock well with New Englands at once, and be prepared to meet this constantly increasing demand.

THE NEW ENGLAND WATCH CO.

Waterbury, Conn.

Fig. 18. From there they go to the man who opens the setting and rubs the jewels to their seat. He does this in the following manner: First the settings, naturally, are chucked. The opening and facing, with jewel, are done with a tool holder

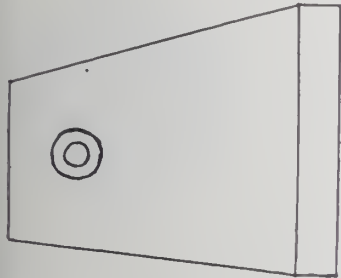
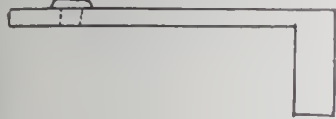

Fig. 16.

like Fig. 19, mounted in the swing rest spindle. The cutter, a, is run into a depth to a top. The diameter is determined, after the machine is once set, by the jewel resting between the finger gauge and the rest stop.

To those unacquainted with this operation it may be stated the machine is set by drawing the tool, with the jewel resting between the finger gauge and the rest stops in Fig. 20, back so that it will cut somewhat smaller than the jewel. Then advance a little at a time and cut and try until you have it large enough to take the jewel. Next your machine is set and you can put any size jewel between the finger gauge and rest stop and the setting just the right size for the jewel. This same system is used in factories in opening wheels for pinions. The jewel is conveyed from the finger

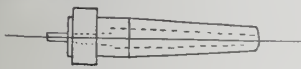

Fig. 17.

gauge to the setting by moistening the finger and pressing it on the jewel. The jewel naturally adheres to the finger and is easily set into place. The swing rest has been allowed to drop forward to allow free handling for the rubbing operation, which is done with a tool shown in Fig. 21. It is supported on a swivel T-rest fastened on the bed, between the head and the jewelers' swing rest. The facing of the setting flush with the jewel is, of course, done after the rubbing operation. Thus equipped, a high rate of speed is obtained in this operation. The plates and bridges are opened likewise, with setting resting between the finger gauge and stop. The jewel settings are all worked to a standard size. The plates or bridges are, of course, held in universal jaws on the face plate or head.

With the jewels spun into bridges, one should give them a proper finish; that is to say, strip the metal immediately surrounding jewel with sapphire cutter. This is usually done free hand with the sapphire shellacked into the holder and supported on the T-rest. It can be done as readily with

the swing rest jewelers caliper if the sapphire is shellacked on a taper, or, rather, in a hole in a taper, to fit the spindle. The speed of machine must be slow. To make a delicate feed where there is no screw feed, hold the spindle firmly with the finger resting against the spindle bushing and easing up a little of the resistance to traverse. After a little practice one becomes expert with the most delicate feed.

Wheel-Cutting Attachment.

In the selection of a tool for wheel cutting one should be governed by its possible uses, such as milling, and with this latter in view we should observe its stability. The three principal features to be regarded in this attachment are the correct setting of cutters, the proper indexing, and the selection of the right cutter. We wish to have properly acting teeth. If the cutter is well made and set central, we will have a tooth that has equal sides and is upright. If, however, we have a cutter that is improperly made, as in Fig. 22, and set on center, we will have a tooth shaped as in Fig. 22. To make a tooth with equal sides with a cutter

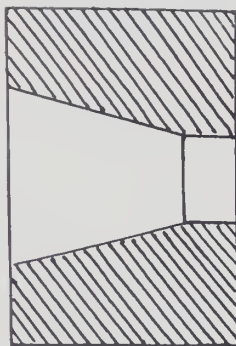

Fig. 18.

as in Fig. 22 we would have to set our cutter off center, which would of necessity make a tooth out of the upright. To set a cutter centrally, turn a piece of brass wire to a point with graver. File the point until the flat on the end is equal to the width of the cutter. Then set as near centrally as you can with the aid of an eyeglass. Test your position on the same piece of brass by using two divisions. The thickness of the tooth is unimportant, as we merely wish to see if tooth is central and upright. When cutting a wheel of ordinary size this method is all right and needs no correction. But in the cutting of pinions with small diameters the error is the more readily seen, and you are in luck if it comes right the first time.

Thus, in Fig. 24, I have exaggerated the error most likely to occur at first, so that it is readily seen which way to move

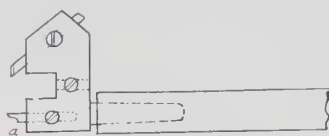

Fig. 19.

the cutter. It may seem the contrary direction at first sight as you look at the pinion. But you must move the cutter towards that side of the tooth which has the longest sides as at a. Frequently we find it necessary to sacrifice the "upright" to the form or shape

desired on the tooth—that is, of course, if not too bad.

The wheel, unless you have a special arbor, is cemented on a brass chuck, and the chuck should be almost the diameter of the wheel, less the double depth of tooth,

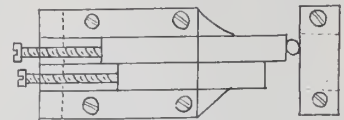

Fig. 20.

and the cutter is fed running against the chuck. Thus the wheel has good support with no danger of its coming loose. To set the cutter to cut the correct depth, first having turned it to proper diameter with a graver, take a cut in two divisions, a little at a time, until the tooth comes to a sharp point as in Fig. 23. Then try two more divisions. In this case you are taking the full depth of cut, and if there is any spring to the attachment it will show a small flat on top of tooth. Go over those two divisions again. This will bring them to a sharp point. Now advance your cutter a little deeper into the work, and most likely this time it will cut as desired. But before removing the wheel, drill and open the hole. It will thus be perfectly true. Indexes are selected as follows: Say we wish to cut a wheel with 72 teeth. If we have No. 72 index we multiply 72 by 2, equaling 144; and 144 and 360 are common indexes. Or we can divide 360 by 72, which gives us five holes on a 360 index for each tooth to cut; that is, move the index around five holes at a time for each tooth.

Perhaps the rounding-up tool, which is by no means as expensive, is found more in use than the wheel-cutting device. In this case we buy a wheel that is scored, or cut somewhat to shape, with the required

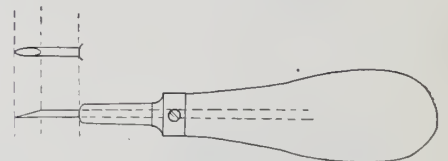
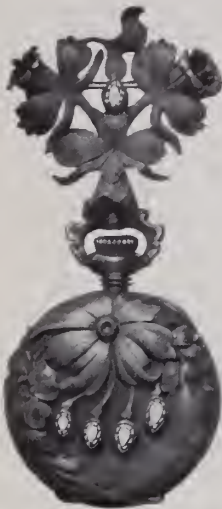
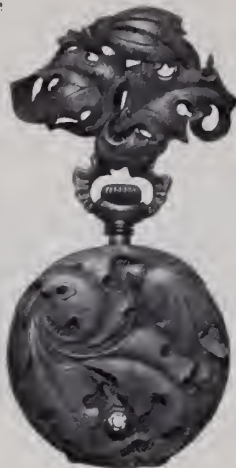

Fig. 21.

number of teeth, but larger in diameter than what we desire. After it is fitted on the pinion we set it up in the rounding-up attachment. The cutters for this attachment are vastly different, having one a third or a quarter cut away. This section is occupied by a thin piece of metal so arranged that one end can be considerably deflected. This acts as a feed or index. This deflection must be adjusted to suit each individual wheel, unless you have several of the same diameter and number of teeth. In the setting of this rotating device—which, by the way, is quite an invention—we, of course, use an eyeglass and set the cutter into the wheel as far as it will go without cutting, and revolve. Then observe if the first tooth on the cutter following the feed is exactly central with space on the wheel. If it strikes the near side of the tooth on the wheel (that is, the side towards the space just passed through) deflect the guide a little more, and the reverse of the teeth



C 300 -4 Diamond



C 304-1 Diamond



C 302-1 Diamond



C 301-3 Diamonds

A.W.C.CO

14-K. and 18-K.

We carry a large and assorted stock of hand-carved, rose finished, solid gold cases in all sizes. The material and workmanship are of the standard that has secured for them the recognition of careful jewelers and a discriminating public. Our dealings are strictly with the retail jewelers, whose trade we earnestly solicit. We do not sell jobbers. Swiss casings a specialty.

Memorandum packages sent upon request.



C 303-2 Diamonds and 2 Rubies



C 306



C 309-3 Diamonds



C 308-1 Diamond



C 310-4 Diamonds



C 311-1 Diamond

American Watch Case Co.,

9-11-13 Maiden Lane, New York.

in the cutter strike the far side. The cutter passes through the teeth but once, and each revolution of the cutter advances the wheel equal to one tooth and places it in position for action on the next tooth. To go to the full depth we are obliged to go around several times. This, of course, is a cut-and-try method, but, as it is mounted on pinion, it is quickly tried and quickly set up for more metal to be removed.

The cutters are selected by trying them in the old wheel and holding them up to the light. Extremes, large or small, are apt to



Fig. 22.

be the result of our first efforts. But, as a rule, the movement suffers from the wheels being too large rather than otherwise. When large they may run all right with power applied and escapement out, but with escapement replaced you will find that, on one of the momentary stops when escape wheel is in locked position, it will fail to resume its ticks. This is particularly true with the fourth wheel, where the power is less. When you get back to the center wheel the effect is not so disastrous, for here we have power to overcome the resist-



Fig. 23.

ance. Nevertheless, it absorbs power and the escapement does not receive the impulse it should.

The Spring or Wire Chuck.

Bad chucks are an abomination, particularly as it is just as easy to make them good as bad, the difference representing a little lack of care on the part of either the operator or foreman. In the manufacturing of chucks, when made for the trade or in the factories for their own use, there is a regular chucking job by which operators become proficient specialists at that particu-

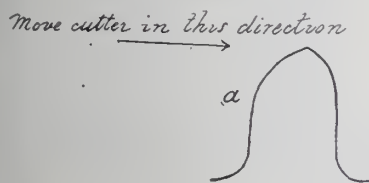

Fig. 24.

lar work. After each operation the lot is inspected, so that, as it reaches the final operation, the chances of a poor chuck going into the market is reduced to "an occasional one." For, no matter how careful and conscientious the inspector may be, bad work will find its way through once in a while and sell, and the chuck thus misrepresents the maker's good intention.

The exterior of the chuck is finished while soft. When hardened and temper is drawn, the chuck is thoroughly cleaned. It is then run on its own bearings in an automatic

machine and the holes are ground true and to size by diamond powder-charged laps which traverse back and forth until the desired diameter is reached. When the chucks are completed they go up for final inspection to be tested for true holes.

They are now run in a perfectly true head with a piece of wire ground true and the exact size of the hole in the chuck, and extending two or three inches beyond. If the end of this wire runs true it passes inspection as being good enough for watch work. But, as before stated, occasionally we buy a poor chuck.

A good range of chuck sizes is given below, though a greater variety is still better: Nos. 4, 5, 6, 7, 8, 9, 10, 12, 14, 16, 18, 20, 22, 24, 26, 28, 30, 33, 36, 38, 41, 45, 50, 60.

Regulation of the Watch Through the Button

THE object of the invention here described, a very ingenious one in its way, is to regulate the watch by moving the index from the outside (by merely turning the button and at the same time pressing a push-piece, as when setting the hands), the necessity of opening the case being thus obviated. The two illustrations, made half as large again as the original, will help to explain the mechanism, says the *Deutsche Uhrmacher Zeitung*.

In Fig. 1, d¹ and d² are two push-pieces. When setting the hands in the ordinary way the first of these push-pieces presses against the lever h in such a manner as to bring the loose minute work pinion into gear with the little steel third wheel u, which in its turn engages permanently with the minute wheel.

The cock b of the third wheel u enables the extremity of the lever h to work into the groove of the loose pinion; it serves at the same time as a banking piece to a pivoted detent c, when the latter is at rest. This detent is constructed as a bridge and can be turned round the screw i. It also covers the end of a short lever a, likewise revolvable round its screw. The extremity of this lever, which is made to turn inwards by the push piece a, engages also

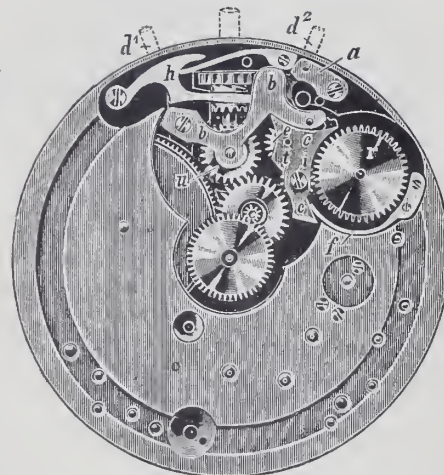

Fig. 1.

with that of the lever h, thus carrying the latter inwards with it; in this way the minute work is also operated at the same time.

The pivoted detent or bridge c covers

two little steel wheels, one of which, f, is geared permanently with a larger steel wheel r, and also with the second wheel e, covered by the bridge.

The lever a is provided with a beveled nose, placed upon a similarly beveled sur-

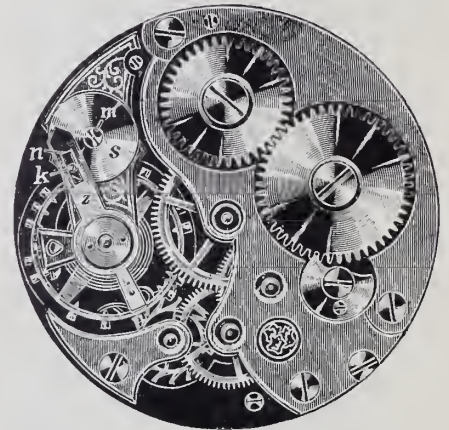

Fig. 2.

face on the detent c in such a manner that the latter turns to the left when the push-piece d² is pressed inwards. By this means the little wheel e is thrown into gear with the third wheel u, and thus the toothed-wheel connection between the minute work and the large steel wheel r is effected.

The arbor of this wheel r is passed through the work plate and the balance cock and carries (see Fig. 2) a flat steel disk s, which is secured to the arbor by means of the screw m and provided with a carrier pin k.

This carrier works into the slit n of the very broad index. When, therefore, the push-piece d² is pressed down and the button then turned, the index can be moved in either direction by this means, as far as the length of the slit n allows.

At the same time the hands of the watch are turned, forwards if the index is moved in the direction of the "acceleration," backwards if the watch is to go slower. If we disregard the "lost way" which is unavoidable with the sixfold toothed-wheel gearing (from the loose pinion to the cannon pinion on one side and to the wheel r on the other), the movement of the hands during the regulation enables us in some measure to judge the distance through which the index should be moved. With every watch, however, it is possible after a time to discover the rate of alteration when, e.g., the minute hand (during regulation) moves over a space of five to 10 minutes.

The principal advantage of the contrivance, however, according to the patentee, Emil Marix, vice-president of the Watchmakers' Association in Munich (Theresienstrasse 46), lies in the circumstance that with this method of regulation the case may remain closed and a tampering with the works is not necessarily involved in the operation. This is specially advantageous if the wearer desires to regulate the watch himself. A watchmaker, of course, can open the case, should any smaller adjustments be necessary to avoid uncertainty arising from the "lost way" caused by the play of the teeth.

SETH THOMAS CLOCK COMPANY

ESTABLISHED 1813

Some of our new
8 and 15 Day
Empires and
Metals now ready
for delivery : :

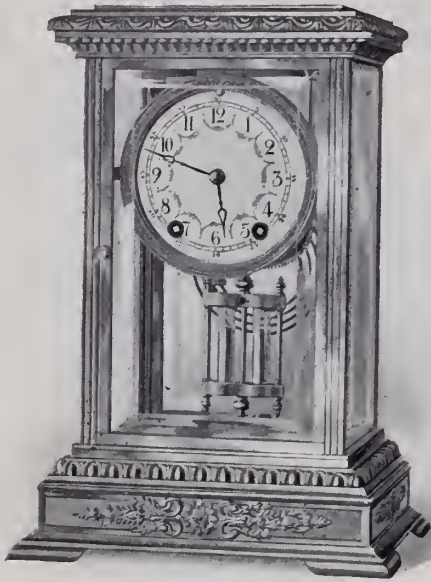

EMPIRE. No. 18.
8 Day.
Rich Gold and Burnished. Height, 12 inches.
Price, \$29.25.



EMPIRE. No. 47.
15 Day.
Rich Gold and Burnished. Height, 19 inches.
Price, \$34.50.

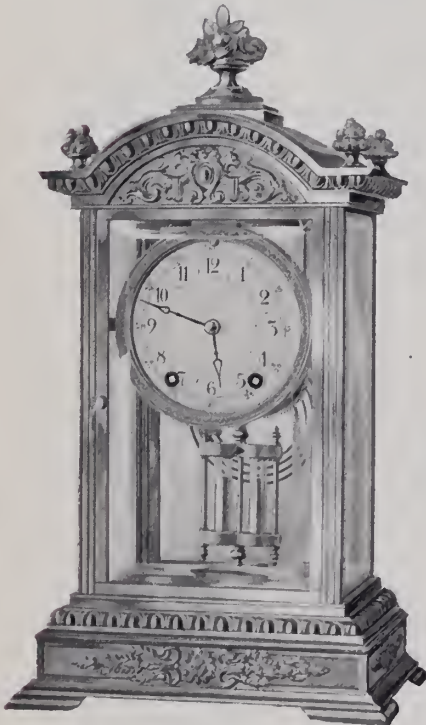

EMPIRE. No. 19.
8 Day.
Rich Gold and Burnished.
Height, 15½ inches.
Price, \$30.75.



IRMA.
Rich Gold and Bronze Art Nouveau Finish.
Height, 18 inches.
Price, \$36.00.



EMPIRE WITH LION. No. 65.
Convex Front. 8 Day.
Gold and Verde Antique Finishes.
Height, 13¼ inches.
Price, \$63.50.

**Please order of your Jobber. If he cannot
serve you then order of us direct**

70 Wabash Ave.
Chicago

SETH THOMAS CLOCK COMPANY

51 Maiden Lane
New York

A CATECHISM OF THE LEVER ESCAPEMENT

Being an Informative and Instructive Series of Questions and Answers for Watchmakers and Apprentices.

QUESTION:—Who first successfully applied the lever escapement to watches?

ANSWER:—Thomas Mudge, an Englishman, about the year 1750.

QUESTION:—What forms of escapement do we find in pocket timepieces?

ANSWER:—We chiefly find the lever, cylinder and chronometer.

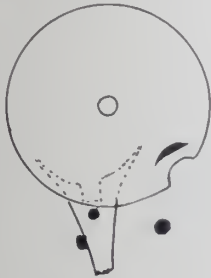

Fig. 1.

QUESTION:—Why is the chronometer escapement not more generally used?

ANSWER:—Its delicate character and liability to "set" when subject to hard usage make it unfit for every-day use.

QUESTION:—What is the objection to a cylinder escapement?

ANSWER:—It is essentially a frictional escapement and is not to be compared for

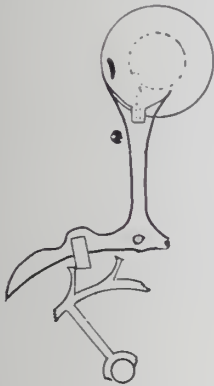

Fig. 2.

accuracy either with the lever or chronometer escapement.

QUESTION:—Which of the three escapement forms mentioned is the most practical and reliable for use in pocket timepieces?

ANSWER:—The lever escapement.

QUESTION:—Which of all the escapements is the most complicated?

ANSWER:—The lever.

QUESTION:—Name the parts which comprise the action of the lever escapement?

ANSWER:—The escape wheel, the pallet jewels, the lever, fork and roller actions.

QUESTION:—Name the various types of the lever escapement.

ANSWER:—The single and double roller, circular and equidistant pallets, club and ratchet toothed escape wheels, straight line and right angle escapements.

QUESTION:—What is meant by the term "single-roller escapement"?

ANSWER:—That form of escapement in which we find but one roller table (Fig. 1).

QUESTION:—What does the term "double-roller" imply?

ANSWER:—A type of escapement possessing two superimposed roller tables—one table carrying the roller jewel and a smaller table which provides for the maintenance of the safety action (see Fig. 2).

QUESTION:—To what are the terms "circular" and "equidistant" applied?

ANSWER:—They have reference to the form of the pallets.

QUESTION:—Which type of pallet is used in American-made watches?

ANSWER:—The circular.

QUESTION:—Name the type in which the lift is most effective.

ANSWER:—The circular form of pallet is certainly the best when it comes to a question of applying power to the balance.

QUESTION:—In which type of pallet is the unlocking resistance least?

ANSWER:—The equidistant.

QUESTION:—By what other name is the equidistant form of pallet known, and why?

ANSWER:—The tangential escapement, as unlocking takes place on tangents.

QUESTION:—Explain the positions of the lockings as regards the pallet staff center in an equidistant escapement.

ANSWER:—The lockings in equidistant escapements are at an equal distance from the pallet staff center, hence the term equidistant.

QUESTION:—What form of pallet is referred to as the pallet with equal lifts?

ANSWER:—The circular type of pallet.

QUESTION:—Describe and explain the construction of circular pallets.

ANSWER:—The lines A B, B C in Fig. 3 enclose an angle of 30 degrees; the lines C B, B D likewise enclose an angle of 30 degrees; the lines A B, B D are therefore 60 degrees apart, and each line respectively intersects the impulse face of each pallet. It will likewise be observed that the circle P P, whose center is the pallet staff C, intersects each pallet's impulse face at the same points as the lines A B, B D; also each pallet lies between the outer circles K¹ K², whose centers are similarly at K. As the pallet jewels are enclosed within concentric circles, centering at the pallet staff, the geometrical expression "circular pallet" can thus be readily comprehended.

QUESTION:—How can we determine if the pallets in any given escapement are of the circular type?

ANSWER:—By using a Swiss dephing tool, placing the female end on the pallet staff pivot, then adjusting the other point so it touches the corner L (Fig. 3); sweep it around, and if the pallets are of the circular variety the corner m (Fig. 3) of the opposite pallet will touch the point of the tool as indicated by the circle K² K².

QUESTION:—Describe the equidistant form of pallets.

ANSWER:—The angles C B A, A B D are

respectively of 30 degrees each (Fig. 4), the line C B touches the locking corner of the entering pallet, and the line B D touches the locking corner of the exit pallet; it will also be seen that the circle R R, whose center is the pallet staff pivot, in like manner touches the corners of each pallet; the lockings are therefore equidistant from the center and at equal distance, viz., 30 degrees apart, from the line A B; hence the expression "equidistant pallets."

QUESTION:—How can we demonstrate practically that a pallet is of equidistant class?

ANSWER:—By using the dephing tool as before explained; the sharp point, however, will be found to touch the locking corners of each pallet as indicated by the circle R R (Fig. 4).

QUESTION:—What is the most practical number of teeth for an escape wheel?

ANSWER:—Fifteen.

QUESTION:—What number of escape wheel teeth are usually embraced between both pallet jewels?

ANSWER:—Three.

QUESTION:—Has an escape wheel with

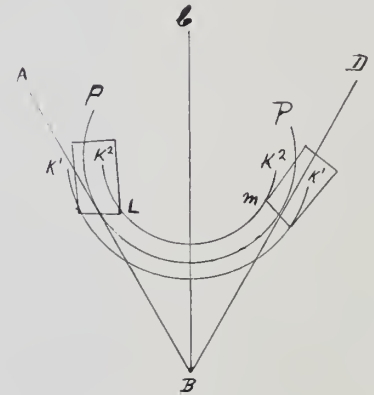

Fig. 3.

15 teeth any advantage over a wheel containing more or less teeth?

ANSWER:—An escape wheel with 15 teeth possesses the advantage both from a geometrical and a practical standpoint.

QUESTION:—Describe that form of escape wheel tooth known as a club tooth.

ANSWER:—To outline and describe a club tooth the following specifications are necessary: Width of tooth, 4½ degrees; pitch

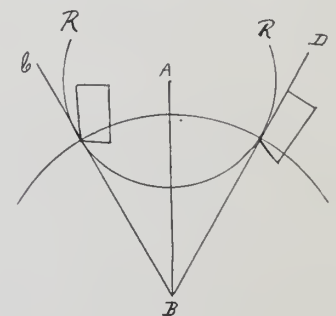
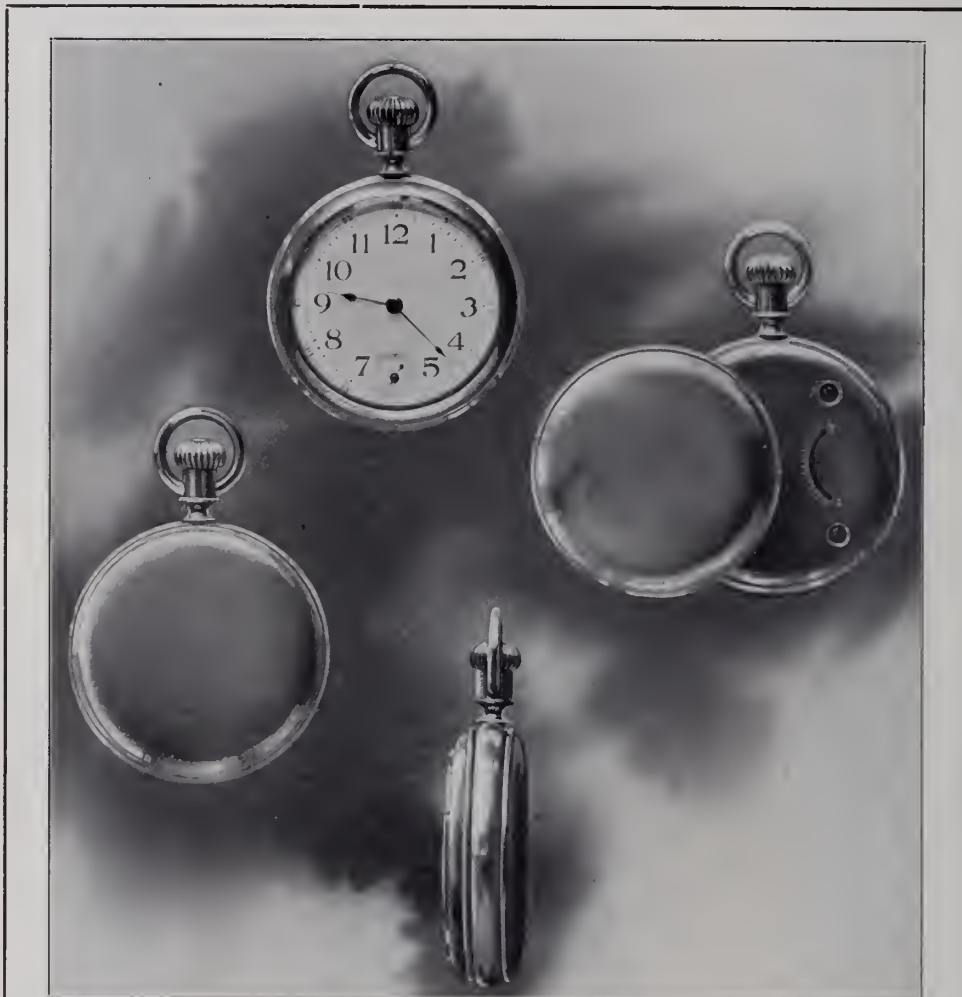

Fig. 4.

of tooth's locking face, 24 degrees; lift on tooth, three degrees. To follow these figures commence by drawing the line A B (Fig. 5) with B as the center of the escape wheel; sweep the circle C C. This circle is known as the first or primitive circle of

“THE AMERICAN” Stem Wind and Stem Set Watch



A Boy-proof \$1.00 Watch

Guaranteed

Stem Wind and Stem Set, 16 Size, Second Hand, Double Dust Proof Back Cover,
Seamless Brass Case, Snap Back, Double Roller Escapement.

WHILE this is the first time we offer and advertise our “American” Stem Wind and Stem Set Watch to the trade, it is by no means a new article. We have been making it for the past two years, experimenting with it, testing and retesting it, gradually increasing our output and manufacturing facilities, and bringing our help to the highest point of efficiency. “The American” is not a trial, but a tried and found true timekeeper.

We do not claim that it is the cheapest watch made to retail for a dollar, but we claim that it is the highest grade made to sell for that price. It has all the good features existing in other makes and several that cannot be found in any, and while it must not be sold for less than \$1.00, it will easily bring \$1.50 and more alongside of others sold at a lower figure.

Sample orders must be accompanied by 85 cents in stamps and will be sent by registered mail only. Quotations furnished upon application.

THE WESTERN CLOCK MFG. CO.

NEW YORK
85 John Street

Manufacturers of the “America” Alarm
LA SALLE, ILLINOIS, U. S. A.

CHICAGO
131 Wabash Avenue

the escape wheel. On each side of the center line A B lay off angles of 30 degrees each, and draw in the lines D B, E B; this now gives us the angle D B E, of 60 degrees. Where the line D B intersects the circle C C draw the line H H'; again where

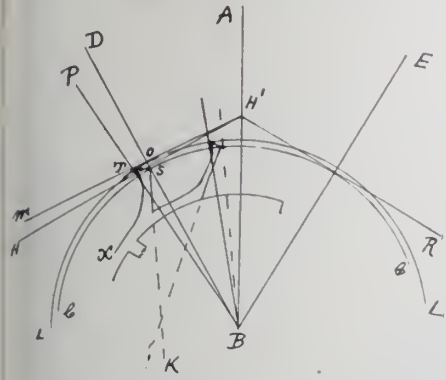

Fig. 5.

the line E B cuts the circle C C draw through this point the line H' R; these lines are tangents to the circle C C, the point of intersection of the lines H H'; R H' is the pallet staff center (equidistant type). Above the line H H' lay off an angle of three degrees, this being the measure of the lift on the tooth. Observe where the line m H' intersects the line D B; this point is marked O; with B as a center and O as a radius, describe the outer circle L L. The tips of each tooth, were we to delineate them, would touch this circle. To mark off the width of the tooth, lay off an angle of 4 1/2 degrees to the left of the line D B; where the primitive circle is intersected by the line D B we have marked

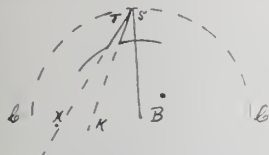

Fig. 6.

it S, and where the circle L L is cut by the line P B has been marked T. By drawing a line, thereby connecting T and S, we obtain the top of the tooth. We now have obtained the width of the tooth, 4 1/2 degrees, and the lift of the tooth, three degrees. We shall next draw in the locking face. In order to do this the protractor is placed at S; then, to the left of B S, lay off an angle of 24 degrees, marking it at K; by drawing a line from S to K we have the outline of the tooth's locking face. We have now outlined the essential form of the tooth as contained between the lines T S, S K, namely, the tooth's width, lift on impulse face, and slant of the locking face. That part of the tooth T to X is filled in without regard to specifications further than to observe that the undercutting is sufficient to clear the discharging corner of the exit pallet as it dips into the wheel.

QUESTION:—What form of tooth do we frequently find in English-made watches?

ANSWER:—The ratchet-toothed escape wheel.

QUESTION:—Describe the ratchet-toothed escape wheel.

ANSWER:—In Fig. 6 is illustrated this

type of tooth. There is but one circle, C C; the points of the teeth arc acute and devoid of lift. In order to form the locking face, lay off from the line S B an angle of 24 degrees; the pitch of the line S K, thus obtained, determines the tooth's locking face. To obtain the width of the tooth from the line S K, lay off an angle of 12 degrees as indicated by the line T X. We now have the pitch of the tooth and the width of the tooth, the tip of a tooth in a ratchet-toothed escape wheel being without lift, the pitch of the locking face is the only important feature in its construction.

QUESTION:—What type of pallet is used with a club-tooth escape wheel?

ANSWER:—We require a pallet which divides the lift, part of the lift being on the pallet's impulse face and part on the tooth.

QUESTION:—If the total lift as per specifications was nine degrees, and three degrees of this lift were on the tooth's impulse face, state how many degrees of impulse should there be on the pallet jewel.

ANSWER:—Six.

QUESTION:—If the total lift in an escapement with ratchet teeth was stated as being 10 degrees, how much of this quantity would you find on the tooth?

ANSWER:—None. In a ratchet-toothed escape wheel all the impulse, i.e., the lift, is found on the pallet jewel.

QUESTION:—Why do we find a wider pallet in an escapement with ratchet teeth than we find in an escapement using club teeth?

ANSWER:—It is again a question of the lift; as stated, the lift is divided between the pallet and the tooth in a club tooth. Thus we obtain a narrower pallet than that employed in a ratchet-toothed escapement where the entire lift is on the pallet.

QUESTION:—From what point is the width of a club tooth measured?

ANSWER:—From the center of the escape wheel.

QUESTION:—From what point is the slant of the tooth's locking face measured—in either a club or ratchet-tooth escape wheel?

ANSWER:—From the locking corner.

QUESTION:—What is the purpose of the slant on the locking face of a tooth?

ANSWER:—To insure the least possible contact of a tooth when resting on a pallet's locking face.

QUESTION:—Explain the purpose of the undercutting in a club tooth—T to X, Fig. 5.

ANSWER:—To allow the pallet to dip into the wheel, without danger of contact.

QUESTION:—Name the angles which form a club tooth.

ANSWER:—The angle of width, the angle of lift and the angle of the locking face.

QUESTION:—From what point is each angle measured?

ANSWER:—The width is measured from the center of the escape wheel.

The lift is measured from the pallet center.

The pitch of the locking face from the locking corner of the tooth.

QUESTION:—What is a straight-line escapement?

ANSWER:—That form of escapement (Fig. 2) in which we find the balance, pallets and escape wheel in a straight line.

QUESTION:—What is a right-angle escapement?

ANSWER:—That class of escapement in which we find the escape wheel and pallets set at right angles to each other.

QUESTION:—Explain the constructive outlines which form a pallet jewel.

ANSWER:—To intelligently explain the subject we shall make use of specifications, viz., width of pallet, six degrees; lift or impulse on face of pallet, six degrees; draw on the pallet's locking face, 12 degrees. Commence by drawing the line A B (Fig. 7); it is well to state that the method of delineation employed is explanatory of pallet jewel form only; having drawn the line A B, lay off on each side of it, the lines D B, B E, containing an angle of 60 degrees. We assume the point A to be the pallet staff center and the point B as the escape wheel center. To the right of the line D B lay off an angle of six degrees for width of pallet; the angle D B S is the required angle for width. We next assume that the dotted line A K passes through the lowest locking corner of the pallet. As the specifications call for six degrees of lift for the impulse face of the pallet, lay off the

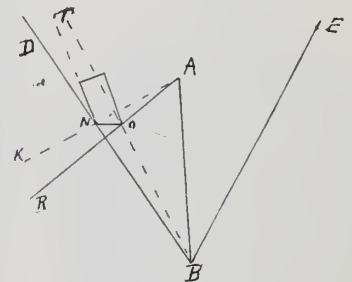

Fig. 7.

required six degrees. As shown, between the lines K A R where the dotted line K A intersects the line D B, we have marked this point as N, and where the line R A intersects the line T B has been marked O. By drawing a connecting line from N to O we obtain the impulse face of the pallet. To obtain the line of the locking face in accordance with the requirements of the draft angle, lay off from the point N to the right of the line D N an angle of 12 degrees. The lines D N T enclose such an angle and the line T N represents the locking face of the pallet.

QUESTION:—State the angles which give form to a pallet jewel.

ANSWER:—The draft angle on the locking face and the lift on the impulse face, and the angle of width.

QUESTION:—From what source is the angle of lift measured?

ANSWER:—From the pallet center.

QUESTION:—Name the source of the angle which gives width to a pallet.

ANSWER:—It is measured from the cen-

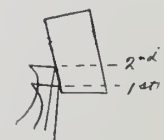

Fig. 8.

ter of the escape wheel.

QUESTION:—From what point is the draw or draft angle on the pallet's locking face measured?

ANSWER:—It originates from the lowest locking corner of the pallet.

Patented in the U. S.

"SECURITAS"

and in Foreign Countries

IF you want to increase your business, buy watch cases with our **Ball-Bearing Bow.**

Such cases are for sale by all first-class jobbing houses, and Ball-Bearing Bows for repairing purposes can be obtained from all material houses.

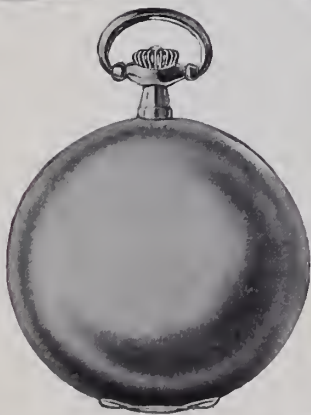

BEWARE OF IMITATION

We will forward to Retail Jewelers any of these cuts shown, **free of charge**, should same be used for publication in their home newspapers.



THE WACHTER MFG. CO.

HARTFORD, CONN.

QUESTION:—Explain the purpose of the draft angle.

ANSWER:—It holds the lever at rest against its banking, thereby preventing the guard pin from coming in contact with the edge of the roller table. It thus insures the soundness of the safety action.

QUESTION:—Is there any objection against draw?

ANSWER:—Yes; it adds resistance to the unlocking.

QUESTION:—Is draw a necessity?

ANSWER:—Draw is essential, but it should never exceed its requirements, namely, just to retain under normal conditions the lever against its bank.

QUESTION:—When an escapement acts under normal conditions, how many kinds of lock are present on a pallet?

ANSWER:—Two.

QUESTION:—Describe them.

ANSWER:—We observe a first and second lock. When a tooth of the escape wheel drops on the pallet, we obtain the first or drop lock. We next observe an increase of the lock, namely, second or draw lock, due to the pallet descending into the wheel. This increase of lock is the result of the draft angle on the pallet's locking face. The extent of this lock is controlled by the banking pin. Both locks are shown in Fig. 8.

QUESTION:—What is the effect of draw lock on the escapement?

ANSWER:—This second lock further removed the guard pin from edge of roller table and from its nature holds the lever against its bank. It is thus an important factor in the safety action.

(To be continued.)

Clean Pocket—Clean Watch.

“WHY do watches get dirty?” said the jeweler. “You’ll find the answer in your watch pocket. Turn it out.”

The patron turned out his watch pocket, sheepishly bringing forth a pinch of mud-colored dust, some lint and a small ball of black fluff.

“There’s the reason,” said the jeweler. “Watches get dirty because the pockets they are carried in are never clean. A watch pocket, my dear sir, should be cleaned out regularly once a week. Observe that rule and your watch’s works will not get clogged up again.

“Another and a scasonable rule is never to lay your watch down on stone or marble. The cold deranges the delicate works.

“Never lay your watch down, in fact, anywhere. Hang it up on a hook, vertically, in the same position it occupies when in your pocket. Watches are made to lie, or rather stand, in that position only.

“Wind your watch in the morning, never at night.”

A. J. Orkin has retired from the firm of Orkin & Miller, Jackson, Miss. The business will be continued by Mr. Miller alone.

The Eckhardt, Drissen Co., Green Bay, Wis., has disposed of its stock of jewelry to S. Feuerstein, a jeweler of that place, who has moved the stock to his own establishment. The Eckhardt concern will retire permanently from the jewelry field.

A CLOCK CASE CONSTRUCTED OF WOOD FROM VARIOUS PARTS OF THE WORLD

THE clock case illustrated herewith contains 2,068 pieces of rare woods of various kinds, many of which have associations of unusual historical interest. This clock was constructed after several years of painstaking labor by L. C. Barnes, of Nelson, N. Y. The case stands eight feet four inches high over all. The frame is made of cherry wood more than 100 years old,

wide. The dark woods are inlaid in the light panels and the light woods in dark panels.

Here is a list of the kinds of wood inlaid in the panels of this section: Quartered sycamore, blue lilac, rosewood, spotted maple, tamerack, barberry, red birch burl, syringa tulip, mahogany, white birch burl, oak, English boxwood, ebony, white lilac, amaranth, white birch, dogwood, black ash burl, Florida wood, tame cherry, cypress club tree, prickly ash, crab-apple, wahoo, brown oak, grapevine, curly applewood, hazelnut, honeysuckle, quince, applewood, red oak, horse chestnut, satinwood, white rose, hazelwood, curly maple, chestnut, southern hazel, black birch, sweet osier and horn beam burl.

The middle section is 16 inches wide, 10 inches deep and three feet high. The front side has a door of French plate glass showing the pendulum. There are eight panels in the upper end of the door. The sides have 26 panels laid the same as those in the lower section. In these panels are the following different kinds of wood: Apricot, green ebony, mahogany, buckthorn, bird’s-eye beech, buttonwood, baywood, juniper, flowering locust, hawthorn, red birch, white willow, blue poplar, osage, orange, black cherry, sweet walnut, cocobola, pin maple, bog oak, mountain laurel, black locust, curly whitewood, black ash, plumwood, mulberry, Ceylon ballwood, gooseberry wood, rosewood, Bermuda red cedar, Hungarian ash, Irish mahogany, curly hard maple and white ash burl.

At the upper end in this section above the door in front are five panels. The center one is the Masonic panel of mahogany, inlaid with a star of boxwood from Mt. Vernon, a square and compass and the letter G, formed of white holly. The opposite corners are trimmed with white birch. The other four panels include two of mahogany and two of white curly birch. These four panels are inlaid with nine choice woods in each panel. These woods are current, catalpa, lilac, mulberry, white birch burl, oak, tame cherry, Japanese plum, English holly, juniper, Manson eaty, Tarterian honeysuckle, Burberry cocobola, horn beam, curly white wood, bitter sweet, amaranth, curly applewood, red cedar, black oak, rosewood, boxwood, hawthorn, syringa, sandal, sassafras, white birch, persimmon, nannieberry and prickly ash.

The upper section is 19 inches wide, 11½ inches deep and two feet high to the cornice. The front side has a door of French plate glass, showing the whole dial. The sides contain 24 panels inlaid the same as the panels in the other sections. The woods inlaid in this section are black walnut, white lilac, tulip, bird’s-eye maple, Chile wood, honey locust, North Carolina cedar, bird’s-eye white holly, sassafras, black mangrove, juniper, button tree, black birch, moosewood, peachwood, southern oak, yellow pine, Chinese cedar, catalpa, yellow



CLOCK CASE BUILT OF RARE WOOD.

and is inlaid with white holly. It is built in three sections. The lower section is two feet high, 22 inches wide and 13 inches deep. This section contains 21 panels in front and 12 on either side, making 45 panels in all. One-half of these panels are mahogany, the rest consisting of different woods of a lighter color.

These panels are inlaid diagonally with different pieces of wood three-eighths of an inch thick and three-quarters of an inch

REMOVAL

FROM

PHILADELPHIA to NEW YORK

No. 35 MAIDEN LANE

Wm. C. Penfold Co.

Largest Exclusive Watch Jobbers in New York

OF

Dueber-Hampden Watches Dueber Cases—Hampden Movements

A COMPLETE LINE ALWAYS ON HAND

Mail Us Your Orders



Bronze Statue Clock



Hygrade Movement.



0, 12, 16 Sizes,
15, 17, 21 Jewels.



Ring Watch
Actual Size.



EIGHT-DAY TRAVELING WATCH.

Exact Size.

The Novelty Watch House OF AMERICA

These illustrations show only a few of the many exclusive novelties we make a specialty of. We are headquarters for ultra flat repeaters in 18K. gold, also ladies' 18K. minute repeaters; gun metal and silver quarter-hour repeaters; chronographs and horse timers of all kinds; thin model and ultra flat watches in gold filled and solid gold; bracelet watches in gold, silver, gun metal and enamel, also with leather strap. Our **HYGRADE** movement is also high grade in quality. We have anything that is made in the Swiss watch line. **Drop us a postal.**

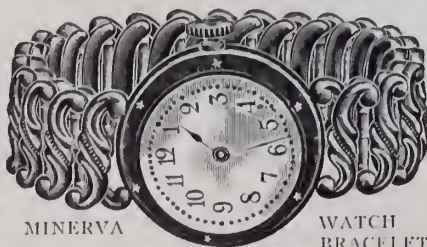

MINERVA

WATCH BRACELET.

KLIPPER BROS.

59 Maiden Lane

New York

barberry, nannieberry and red cedar. The cornice is attractively designed, with Dent blocks two inches square and half an inch thick, inlaid diagonally from corner to center. An acorn-shaped piece hangs in the center. The Dent blocks are of satinwood, mahogany, Australian locust, French walnut, bird's-eye maple, red cedar and umac. They are inlaid with 50 different kinds of rare woods.

The facier is of mahogany, inlaid with 10 different pieces of woods. In the center of the facier in front is a diamond-shaped piece of ginseng root, inlaid between a piece of amaranth and smoke tree. The crown moulding is of carved curly applewood.

The roof has three sides and is shingled with 300 woods with 930 shingles cut at the lower end to a point. The projection at the top of the lower section is a solid piece of cherry over 100 years old. It is made concave on the upper side. In this projection are 30 memorials of prominent personages of the State, county, etc. They include ex-Cabinet officers, Congressmen, Senators, Assemblymen, Justices of Supreme Court, lawyers, doctors, bankers, teachers, merchants, manufacturers, contractors and 33d degree Masons. The memorials in this projection are three-fourths

OAK	BARBERRY	BLACK WALNUT	CRAB WOOD	EBONY
SMOKE TREE	FROM GRAVE OF NAPOLEON BONAPARTE			BLUE POPLAR
CATALPA	CHARTER OAK OF CONNECTICUT			GEORGIA BEECH
	WILLIAM PENN TREATY			
	CURLY APPLE WOOD			
ROSE WOOD	L.R. SYCAMORE	BITTER SWEET	NANNIE BERRY	FRENCH WALNUT

PANEL OF INTERESTING VARIETIES OF WOOD IN THE BARNES CLOCK-CASE.

of an inch wide and three inches long, trimmed on each side with two kinds of wood and on the ends with one kind. They are not sunken or raised, but finished with the exact shape of the projection and show the memorials and trimmings 12 feet from the case. Among the memorials and trimmings are: Stag horn sumac, trimmed with black oak, wahoo and rosewood; Russian mulberry, trimmed with redwood, tulip and smoke tree; bird's-eye birch, trimmed with oak from the boat *Defiance*; oak from Commodore Perry's boat, trimmed with blue poplar, nannieberry and black birch; citron wood, trimmed with oak, bog oak, etc.

The upper projection at the top of the middle section represents the press of Madison County, N. Y. Here is a silver plate giving the names of 13 papers, with the date of the first issue. They are sunken panels composed of choice woods. Since the photo was taken there has been added to the case one more panel constructed of 21 choice woods. Three of these woods are of historic interest. One is a piece of oak from the old Charter Oak of Connecticut, in which the charter was hidden. This oak was a large tree, as history records. At 10 minutes before 1 o'clock on the morning of Aug. 21, 1856, and just 38 years after the old charter itself had passed away, that tree also ceased to be. At this time the

hollow in the tree was so large that a fire company of 27 men stood up in it together. This historical wood is in the center of the panel, three-quarters of an inch wide and three inches long. The wood by the side of this was taken from a tree in Pennsylvania under which William Penn signed the treaty with the Indians in 1682. It came into the possession of Mr. Barnes from a reliable source. The other one is a weeping willow from St. Helena. Napoleon Bonaparte, it is claimed, was buried under this tree in 1821. These three historical woods are placed side by side and trimmed with 14 rare woods. A diagram of this panel is shown herewith. This clock case contains wood from almost every important country on the globe. There are also represented 158 kinds of wood from New York State, most of which were cut by the constructor of the clock himself.

The historic woods include a piece of oak from the *Lawrence*, Commodore Perry's ship, which achieved a victory on Lake Erie, Sept. 10, 1813, and the ship which floated the flag that bore the inscription, "Don't give up the ship." There is a piece of oak from the *Defiance*, the ship that sank when England took Canada from the French; a piece of boxwood from a tree in Mt. Vernon, under which tree ex-President Washington was accustomed to sit and read; a piece of oak from a bridge built across the Mohawk river above Albany in Revolutionary times; a piece of hard pine from the floor on which Colonel Elsworth stood when he was shot while taking down the rebel flag; sweet walnut from a pole raised in Nelson, N. Y., when James K. Polk was nominated President of the United States in 1844; a piece of pine from the first post-office case at Nelson, N. Y., built in 1817; mahogany, black walnut and baywood taken from the old Albany State Capitol.

The front corners in the top and bottom section are finished with a quarter round of curly applewood and inlaid with diamond-shaped pieces of rare wood. The corners in the middle section are shingled with 31 varieties of woods collected in New York State. The door in this section is inlaid with barberry. The glass has a border with corner ornaments bearing the date 1902, the time when the construction of the clock was begun. It is moulded around the glass with 24 different kinds of wood.

The moulding around the glass contains 22 different woods. This moulding has a border that was wrought by friction.

The works in this clock were purchased of the Seth Thomas Clock Co. The clock strikes the half hour and the hour.

Stephen D. Engle, Hazleton, Pa., maker of the world famous Engle clock, that has been exhibited in all parts of the globe, has just presented to Yale College, at New Haven, a tellurian of his own invention that is said to be more simple and better adapted than any other in existence to the study of the motions of the earth and moon.

According to the *Anzeiger*, of Berlin, the Princess Hermine, of Reuss, has no mean ability in the science of watchmaking. It is said that much of her work has been shown at various exhibitions held in Germany.

Useful Tools for the Watch Maker's Bench.

Cutter for Pendants.

THERE are various bushings in the market to line the pendant holes; it is, in fact, difficult to make a selection. The more difficult part of the work is the correct adjustment of these bushes.

The special cutter which is represented herewith in an enlargement of about five times is very useful for preparing the holes intended to receive the bushings. It may be



TOOL FOR CUTTING PENDANTS.

employed with the lathe or the drill bow and can be made to turn both ways.

Its bit is formed by a cone, k, notched at a as far as the middle. The faces being well polished and the tool suitably hardened, we have two cutting edges which produce a neat and rapidly made conical hollow.

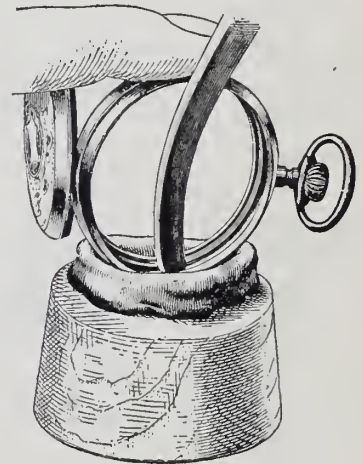

HOW THE DENTED CASE IS HELD.

To Remove Dents from Watch Case Rims.

Ph. Bulle publishes in *La France Horlogère* a process for pressing out light dents which appears useful, for which reason we will give it here. The watchmaker is frequently confronted with this job, and the dents are not always bad enough to evoke the aid of the casemaker. For such cases the method described herewith will suffice.

A small block of wood is required on which a piece of sealing wax has been allowed to melt. While the wax is still soft the rim of the case is pressed into it, turning the rim on its axis so that a good impression of the same is had, but the dent is not visible in the wax. When the wax has hardened the dent is pressed out from the inside with the smoothed end of a pair of pliers or other suitable tool, the sealing wax serving as counter mould.

The same process ought to prove useful

ROCHELLE
CLOCKS



A Watch Clock!

WHAT DOES IT MEAN?
SIMPLY THIS!

Rochelle Clocks are constructed the same as good American watches.

Every clock is carefully assembled, regulated and inspected, before leaving the factory.

The teeth in all wheels and pinions are cut on automatic machines. (Not punched out.)

The balance wheels are perfectly poised.

The Hair Springs are vibrated.

Our Main Springs are made from the best imported spring steel obtainable, they will not set or break. All parts are interchangeable.

We sell our movements to many of the Ormolu Gold Case Makers in the United States. Jewelers should insist on having our movements, as they are the best and cost no more.



No. 158. Height 4½ inches, each.....List \$4.15
Subject to Jobbers' Discount.
Satin Ormolu 24k Gold Finish, 2 inch Ivorine Dial,
One Day Time.

No. 1. Nickel, One Day Time, each.....List \$1.50
Subject to Jobbers' Discount.
2-inch Ivorine Dial, with Second Hand, Bevel Glass Face.
The above cut is exact size.

EVERY CLOCK WARRANTED

Try Rochelle Clocks

They are the Best

ASK YOUR JOBBER FOR THEM. IF HE CAN'T SUPPLY THEM, SEND YOUR ORDERS DIRECT
Send for our new Catalogue. 100 Beautiful Designs in Ormolu Gold, French Bronze and Silver Gray Finish

ROCHELLE CLOCK & WATCH MFG. CO., Main Office, Rochelle, Ill.

CHICAGO OFFICE: 64 Wabash Ave.

N. Y. OFFICE: 67 Park Place

SEATTLE OFFICE: 625 First Ave.

THE

TATTOO

(Trade-Mark Registered in U. S. Pat. Office Aug. 29, '05)

A
T
T
O
O

A Good Timekeeper

A Sure Alarm

4½ Inch Case

Write for description and prices

SOLE MANUFACTURERS

THE NEW HAVEN CLOCK CO.
NEW HAVEN CONN.

U. S. A.



There IS no TATTOO but the NEW HAVEN TATTOO

or the removal of slight dents from the back or lid of the cases, too.

False Dial Feet

The dial feet are often too short and too weak, or the notch for the screw is so bad that it does not take properly any more, thus giving the watch repairer considerable trouble. Although it is possible to place a defective foot, it is nevertheless preferable to dispense with this operation.

A Swiss watchmaker has had a really good idea in this connection, and has put on the market false dial feet which are destined to render good service.

The cut shows one of these feet in two

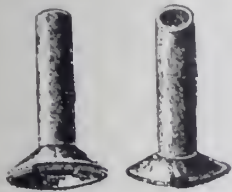

FALSE DIAL FEET.

views and will render long explanations unnecessary.

It consists of a brass tube with a sort of mouthpiece. This tube is adjusted on the damaged dial foot, and is soldered on with the broad part turned toward the dial. The defective foot is thus reinforced and the notch can be repaired at the desired spot in a substantial manner.

Replacing the Pivots of the Center Wheel

In making a very complete repair of a watch it is almost invariably necessary to polish the pivots of the center wheel, and sometimes even to reshape them with the taper. In a special chapter devoted to this operation "L'Horloger à l'Etabli," third

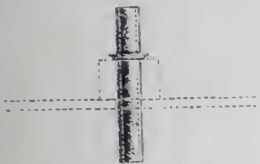

DEVICE FOR REPLACING PIVOTS.

edition, points out the most practical method of carrying out the operation.

This is all very well, but sometimes we find pinions the pivots of which will not stand turning down or even polishing, because they are too thin. In such a case it is necessary to replace the pinion in order to make a proper repair. As this is too costly an operation for some of the cheaper watches, it became necessary to find a means of surmounting the difficulty.

A concern at La Chaux-de-Fonds, Switzerland, manufactures and has placed on the market a special pivot, the use of which is often a great convenience. These tempered and polished tubes are manufactured in a variety of sizes and fitted with a shoulder. They are of the length required to cover the pivot of the center wheel from end to end and to form a pivot at each extremity.

In adjusting them it is necessary first to remove completely the two pivots to be replaced. The pivot hole is then enlarged with the aid of a drill to such an extent as to permit the entrance of one of these tubes, which is driven into place with the aid of a few taps of the hammer.

The figure, borrowed from the *Deutsche Uhrmacher Zeitung*, shows one of these tubes adjusted in a pinion; it suffices then to shorten the two extremities to the desired size and to set the hands arbor.

These pivots are also available for use where it is necessary only to replace one of the pivots. In such case the hole is enlarged only as far as one-half of the pinion, and the new pivot is shortened in such a manner that when adjusted in the enlarged hole it will be of the correct length required for the pivot. This is a little invention that should certainly be very well received.

A Novel Work-Bench.

In the *Deutsche Uhrmacher Zeitung* M. E. Reincke gives a description of a model combination work-bench for a watchmaker who also does repair work on jewelry and watch cases. He has devised this work-bench as a result of progressive consideration, and many repairers will without doubt find it worth reproducing.

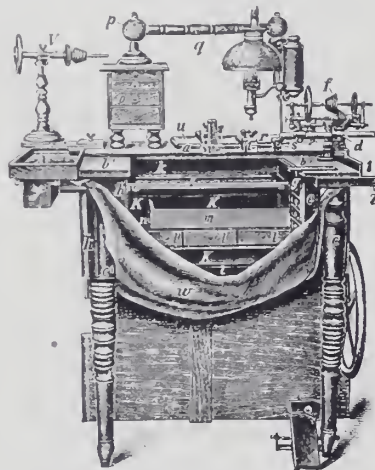

A COMBINATION WORK BENCH MADE BY A GERMAN WATCHMAKER.

The bench itself consists of three planks or boards, of which a forms the top of the table, while the two transverse boards, b and b', are fastened by means of screw bolts to the plank a. To the two transverse boards are attached the legs, c and c', of the bench. At the opposite side the bench is fastened to the wall, or to the front of a window, by means of two iron brackets. It is not necessary to say that where the bench is to stand alone it requires four legs; but it is better to set it up in the manner indicated, as this insures perfect steadiness—a most important requisite in the case of work done by means of a flywheel, operated by foot power, because all vibration caused by the revolutions is thus avoided.

On the right, attached to the transverse plank b, is the lathe d, with the spindle bench. Under this end is placed the cabinet c, with the drawers containing the parts of the lathe and all the tools employed for turning. On the right, behind the lathe, above the bench, is placed the transmission, f.

A vise board, g, can be attached to the bench by means of a thumbscrew placed beneath the board. This board is movable; it can, in consequence, be pushed to one side when no longer needed; thus it does not interfere with work on the lathe, and

also permits of both arms resting on the bench. When the vise board is needed it is only necessary to turn it into the desired position and fasten it by tightening the thumbscrew—a much more rapidly effected operation than that of attaching to the vise the vise board, universally employed, especially as the latter is always likely to be mislaid. With this arrangement it is always ready for use.

Under the transverse plank, on the left hand, is another drawer, h, containing tools and materials, supplies, etc. The spare space between the two boards b and b' serves as a receptacle for several boards that can very readily be changed. One of these boards, i, drawn forward in the cut, has been inserted in the drawer k. All these boards work in grooves; they are by this means made so firm that they will not yield when worked on.

Two or three can be employed, the first being available for watch repairing; the tools required are always accessible. The second board receives tools for doing jewelry work and repairing watch cases; the third can be used for working on larger clocks, for engraving, etc.

Tools required for any kind of special work are always to be found together on the same board when not in use, and are always ready when wanted. In order to receive these boards the bench is provided with a receptacle, k, where they are disposed on slides, one above the other. This case also encloses a drawer, l, and a box, m, for clamps, brushes, etc., also a box, n, for flasks of benzine, alcohol, etc. The upper part of the bench, a, is reserved for machines for staking pinions, for rounding up, and other tools of large size.

On top of the bench, a, there is placed a cabinet, o, for supplies. This cabinet supports the foot p, that carries the arm q of the quinquet working lamp. It is needless to state that instead of attaching this foot to the cabinet o it could be fastened to an independent mounting. By means of an arrangement of joints the lamp can be placed instantly in any desired position. As it has no foot, it occupies no room on the bench, and it is not necessary to remove the tools to determine just where to place a standing lamp. It is therefore always possible to use all the free space under the quinquet.

A third transverse plank, n, can be made to slide backwards or forwards, but can be fixed by means of a thumbscrew on top of the bench a. It is considerably shorter than the other two transverse planks, b and b'. On the board r we find the vise, which serves to hold the Jacot tool, and which can be used for small vise work. It also carries a clamping apparatus, equipped with bolts and thumbscrews. This apparatus serves to secure a simple lathe, operated by hand, which is very convenient—above all for particular work, such as turning cylinders, arbors, balance staffs, etc. When this board is not in use it is only necessary to push it back so that the space is left free for other work.

In addition to this third transverse board there is also a fourth, u, which can be pushed forward or backward, like the one described above, and can likewise be fixed by means of a wing nut. This plank car-



The above TRADE MARK is well known to you, because it is on every watch and watch movement made by the LANGENDORF WATCH CO.

The more of our large line you carry in stock, the more profitable and satisfactory are

YOUR SALES

Perfect Interchangeability of parts renders repairing easy.

Do not accept substitutes, but insist upon getting the genuine L. W. Co. make. It's far the cheapest after all, as the quality is such you may

DEPEND UPON

If your jobber cannot supply you with

THE RIGHT KIND of GOODS

write to the Sole Agents for the United States,

AMERICAN-SWISS WATCH CO.

1 Maiden Lane, New York
CUSHMAN BUILDING

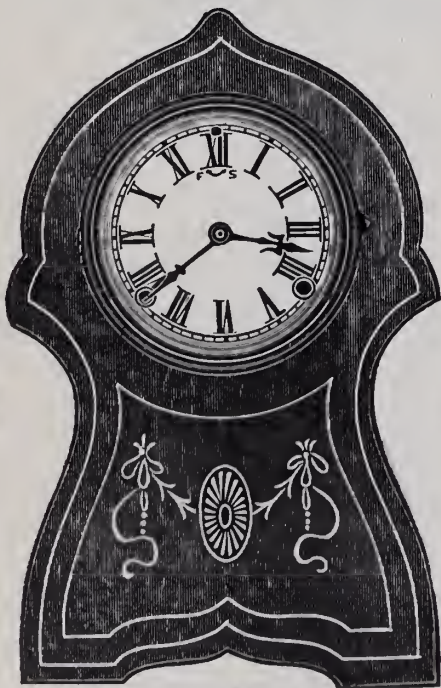

MANCHESTER
Height 13¾ in. Width 8¾ in.

SESSIONS CLOCKS

Superior Finish
Popular Prices

We have added a number of fine marqueterie cabinet clocks to our line which will interest you.

The Sessions Clock Company

FORESTVILLE, CONN., U. S. A.

New York Salesroom, 37 Maiden Lane

HALL CLOCKS



Elliott's
Celebrated
Tubular
Chimes

HARRIS & HARRINGTON,

12 BARCLAY ST.,
NEW YORK

Sole Agents to the Trade
for
J. J. ELLIOTT & CO.
LONDON.



THE **R&L** OIL

NEVER
GOES
WRONG

The trade from ocean to ocean is praising this wonderful oil. IT POSITIVELY WILL NOT GUM. Can you say as much for the oil you are using? Send 25c. to your jobber for a bottle, and end your oil troubles.

RANLETT & LOWELL CO.

SOLE MANUFACTURERS

Jewelers' Building BOSTON, MASS.

Wholesale Selling Agents

M. SICKLES & SONS	Philadelphia
SWARTCHILD & CO.	Chicago
NORDMAN BROTHERS CO.	San Francisco
D. C. PERCIVAL & CO.	Boston
CHAS. MAY & SON	Boston
DANIEL PRATT'S SON	53 Franklin Street, Boston
SUSSELD, LORSCH & CO.	New York City
H. S. MEISKEY CO.	Lancaster, Pa.

HERMANN GRABEMANN

Reliable Watch Repairing

My work you can call your own

Trade References furnished A trial solicited

81 NASSAU ST., NEW YORK

JULES JÜRGENSEN

Watches and Chronometers

PARIS—"THE GRAND PRIX"—1900

SOLE
RUDOLPH & SNEDEKER
65 Nassau St., New York
AGENTS

WATCH REPAIRING

FOR THE TRADE

Careful, Reliable, Prompt Work. Trade References. Price List on Request.

A. D. PAPIAZIEN

71-73 Nassau St., Cockroft Bldg. NEW YORK

ries another vise board, v, which can be used in repairing jewelry. It is intended for the holding of rings and other articles of jewelry.

A calf skin stretched under the bench is for the purpose of catching anything that may drop from the hands while at work. It is so arranged that the fallen article is always to be found at the bottom, and can be recovered by a single movement of the hand.

The bench may also be furnished with an additional box, x, very convenient for receiving files and other tools. Beneath this box still another drawer may be introduced. By means of the same thumbscrew that fastens the vise board g we may also attach another small board for the accommodation of a small grinding machine for sharpening gravers and other edge tools, for perforating dials, polishing cases, etc.—work which we do not care to execute on the lathe, not wishing to soil it, or because of the disturbance of other work on the bench. This tool is operated by the transmission f. Its disposition outside of the bench causes the waste to fall on the floor.

Above the bench another transmission, v, may be located for operating drilling and milling tools, etc. These latter are then combined on the transverse board b¹. On the same board we may also attach a heavy vise for large work, all vibration being neutralized on this spot.

The use of this bench will effect a great economy of time. The tools and supplies are arranged in such a manner that they can be reached by a single movement without having to rise. Numerous objects are thus collected in a limited space. Although the finishing lathe may have to be used at any moment, it will never interfere with the other work. It is sufficiently accessible to be approached from any direction; all the parts of the lathe are at hand and can be quickly put away after use. The working boards likewise furnish the notable advantage of presenting, within easy reach, all the articles and tools required for each special class of work.

Another good point in this bench consists in being able to rest both arms on the ends of the transverse boards, which assures the greatest steadiness in the execution of difficult work. The movable lamp, as well as the calf skin stretched beneath the bench, are equally advantageous. The flasks of benzine or alcohol, the vise boards, the brushes, the cleaning material—each article in its designated place; in short, this bench for the watchmaker and jeweler is distinguished, to its manifest advantage, from ordinary benches; it is always neat, does not present the unsightly appearance of tools, materials, supplies and other articles thrown pell-mell in a state of disorder that cannot fail to occasion considerable loss of time.

Sherman T. Waldron, Glidden, Ia., has sold his interests at that place to W. W. Ratcliff.

A collection of grandfathers' clocks, said to be of particular interest and large extent, is owned by J. Norton Martin, Allentown, Pa. Mr. Martin has recently added a new acquisition to his collection, consisting of a clock which was made in Germantown, Pa., 130 years ago, by John Jaggy.

Isochronism.

BY H. REINECKE.

IN continuation of the discussion of the subject matter of my contribution in the issue of Jan. 1, under the title "Watch Repairing," I shall call attention to the difficulty which has been experienced by some of the most talented horologists in analyzing the principles of isochronism. Such principles when appertaining to a balance spring pure and simple are much more readily understood than when we propose to explain them in connection with a balance or the escapement of a timepiece.

The isochronism of the vibration of balances is principally adjusted on marine chronometers and on watches having detached escapements, which comprise the detent spring and the lever escapements. The latter is not so well adapted to such adjustments as the former, which requires no oil on the escapement and which imparts an impulse to the balance in every alternate vibration and in one direction only, while the lever escapement imparts impulses to the vibrations of the balance in each vibration and in both directions.

The disturbing factors in all detached escapements is the unlocking of the escapements, which interferes much more seriously with the time-keeping properties of a lever escapement than with the chronometer escapement, as the spring detent in the latter is an unchangeable factor, while the oil with its ever-changing condition, etc., alters the unlocking resistance of escapements which may need oil.

Isochronism as an original subject in horology was discussed with much vigor by the old masters when applied to the balance springs of marine chronometers during the closing years of the 18th and the beginning of the 19th centuries. In this connection it may be interesting to reprint an extract from L. U. Jürgensen's work on the "Higher Horological Art," issued in Copenhagen in the year 1842, but taken from an earlier work by Urban Jürgensen, published in 1804. This extract was translated by Victor Kullberg and published in the *London Horological Journal* as far back as February, 1877. This extract is of technical and historical interest.

The application of isochronal adjustments of any extent to the lever watch is of a more recent date and quite fresh in the memory of the writer. During the last 50 years and over I have applied myself zealously to the study of the subject of isochronism. It is clearly understood by well-informed horologists that the principal point of inferiority attributed to the lever escapement when being compared to the chronometer or spring detent escapement is the need of oil. This necessity causes any comparison with the lever escapement to show a gradual tendency of developing a losing rate, which tendency also causes an increase of the resistance to the locking of the escapement. The disturbing effect of such increased resistance is felt more in small watches with short levers and low-angled escapements; but it is hardly felt in large watches with strong mainsprings, long levers and normal impulse angles, where the unlocking is assisted by the great momentum of heavy balances. It is a matter of

a well-confirmed experience in regard to isochronism that with the lever escapement the short vibrations have a tendency to be slow, and this tendency is in part overcome by reducing the unlocking resistance by all means available and by increasing the motive power. The latter remedy is pointedly asserted by James Ferguson Cole in his treatise on isochronism published several years ago in the *London Horological Journal*. The above-mentioned extract from Mr. Jürgensen's work reads as follows:

"The vibrations of the balance always become smaller the longer the watch goes, because the friction increases through dirt and the thickening of the oil, and prevents also the train from exerting all its power on the regulator, and this receives, through the thickening of the oil on its pivots, a new resistance, which is still another cause of diminishing the arcs of vibration. The shaking to which pocket watches are exposed in carrying, or which marine chronometers are exposed to at sea, act more or less on the vibrations of the balance, and alter more or less the extent of the vibrations. These alterations in the extent of the vibrations are very detrimental to a perfect regularity of rate in all watches. Two talented men have done away with this drawback, and given us the means to make the long and short vibrations of equal duration (or in the same time) (isochronous).

"A suitable isochronism of the vibrations of the balance is the foundation for perfection in chronometers; both the celebrated artists whom we have to thank for isochronism in the spiral spring have arrived at the result in different ways.

"Pierre le Roy's method is usually followed. It is based on this: That a very short spring of equal thickness is exposed to more strain than a longer. The longer vibrations are therefore completed in shorter time than the smaller. A very long spring, on the contrary, is much less strained in the same vibrations, or less wound up than the first mentioned, and through that the long vibrations are performed slower than the shorter. Between both these lengths exists a middle length, which makes the long and short vibrations of equal duration; and this fact has been demonstrated completely by actual experience.

"Ferdinand Berthoud's method of making the spring isochronous is founded on quite a different principle to that of Pierre le Roy, because he finds the isochronism through the form of the spring, and not through the length. Ferdinand Berthoud made the turns of the spring proportionately thinner as they receded from the center (*en fouet*, slash of a whip). In this way a short spring like Le Roy's can also be isochronous.

"Both methods are useful; but whenever there is an opportunity Le Roy's is to be preferred, because a wire of equal thickness can be used. In watches whose form do not always admit of a long spring F. Berthoud's method must be resorted to; but during the process of doing this we meet with the great difficulty of making the spring wire the exact, and all through necessary diminishing, thickness.

"We will come back to this subject of

isochronism, or uniform time, and then give the difference which has been considered to be most suitable between the largest and shortest vibrations, because experience has proved that, in order to get a chronometer to go regular for a long time it is necessary to abstain from a perfect isochronism, which we will refer to under the timing of chronometers. The necessary tests referring to this cannot take place before the watch goes and the various parts belonging thereto have arrived at the greatest perfection.

"The form of the spring in marine chronometers is cylindrical. In this way the turns are not likely to touch when the vibrations are very large, and the maker can also easier make this kind of springs than flat ones.

"The large and small arcs of vibration are isochronous when they are completed in equal times. The correctness of marine chronometers depends principally on the necessary isochronism of the vibrations of the balance. In a chronometer with a remontoir escapement the vibrations are isochronous of themselves, because the extent of the vibrations remain constant; the extent of the vibrations cannot alter, provided the oil is unaltered; and in this way isochronism is obtained by means of the escapement. This is, however, not the case with the usual spring detent escapement; the alterations in the motive power and the friction on the pivots, through the thickness of the oil, have an influence on the extent of the vibrations, which become smaller the longer the watch goes.

"It would therefore be well to use a means by which the increased friction, through the thickening of the oil, will be prevented from having any influence on the duration of the vibrations of the balance. As before mentioned, isochronism can be obtained by means of the spring in two different ways, viz., Ferdinand Berthoud's or Pierre le Roy's methods. First, after the watch is ready and in going order, can we begin with the isochronism and make sure that the nature of the spring is such that it will make the long and short vibrations in equal time. This is done by setting up the mainspring, which increases the vibrations, or by letting down the mainspring, which causes the vibrations to fall off. By this means can man, without much trouble, obtain any kind of vibration which is considered necessary.

"In order to ascertain whether the isochronism is right or wrong let the watch go, say 12 hours, without disturbing the spring; this may be either fast or slow or mean time with the regulator. After that increase the power of the mainspring by the means before mentioned, the vibrations become larger and let the watch go as many hours as before, and note its rate. After that the mainspring is let down, the vibrations become smaller and again let it go the same number of hours and note the rate. If it is now found that the long and short vibrations are performed in equal time, the spring is isochronous. If, again, the large or small vibrations are slower or faster than the usual vibrations when the spring is in its ordinary tension, then it is evident that the spring is not isochronous.

"As we have said before, isochronism can

be obtained by using a longer or shorter spring. A very short spring makes the large vibrations quicker than the shorter vibrations; and a very long spring, which otherwise has the same strength as a short spring, makes, on the contrary, the long vibrations slower than the short. It is therefore natural that between these two lengths a suitable length can be found, which makes the long and short vibrations of equal duration (isochronous). When the large vibrations are slower than the short, so can the error be prevented by shortening the spring; when the opposite takes place, a longer spring must be put to the watch.

"On grounds which we will presently give, complete isochronism of the vibrations of the balance has of late been discontinued; it has been found more suitable to make the short vibrations rather faster than the large, so that when the chronometer goes to mean time when vibrating 450 degrees, the same chronometer, in 24 hours, must gain about five or six seconds when the vibrations have been reduced by means of the letting down of the mainspring to about 300 degrees. It is necessary, in order that the chronometer may preserve its rate for a long time that the short vibrations are quicker for the following reasons.

"The strength of the pendulum spring diminishes, if ever so little, through the going of the chronometers, and the oil on the scape pivots thickens to a greater or less extent; both these causes produce a loss of time in the watch, and the arcs also become smaller through the thickening of the oil. The chronometers will only keep a regular rate for a long time, when the short vibrations increase in quickness so much as the loss of strength in the spring and the thickening of the oil retards them. Another reason why a perfectly isochronous spring should not be used is that a watch fitted with such a spring would lose on its rate, either in vertical position or carried through the increased friction on the balance pivots; besides this, that the perfectly isochronous spring does not correct for the increased friction in vertical positions, it has another important defect, namely, if a watch is adjusted in horizontal position between 20 and 30 Reaumur it will not go the same in vertical positions, because the resistance through thickening of the oil is more felt in vertical than horizontal positions, and as the increased friction produces loss of time, such a watch or chronometer will lose more when exposed to freezing or below freezing.

"This defect is removed by using a spring that causes the vibrations of the balance to be quicker the smaller they become, because when the watch is in vertical position it falls off in the vibration through the side friction on the pivots. Consequently, when the vibrations increase in quickness, so much as the friction and thickening of the oil retard them, then the watch will keep its rate under all conditions, even in the greatest cold.

"Through the trials which of late years have been made of the influence of the barometric pressure on regulators and marine chronometers, it has been found that the barometric error is prevented by using springs that gain in short vibrations—five to six seconds in 24 hours—with a differ-

ence in the extent of the vibrations of about 150 degrees.

"Pierre le Roy's method is usually employed as before mentioned. This method is founded on the principle that a very short spring, equal in its thickness throughout, is strained more than a longer spring. The large vibrations are therefore completed in quicker time than the shorter ones. A very long spring, on the contrary, is less exerted, and the long vibrations therefore are slower than the short. Between these two lengths there must be a middle length, which makes the vibrations isochronous, and another length for making the short vibrations the desired quickness. It is, however, necessary to make many trials with long and short arcs and different lengths of spring, because there are so many causes for disturbance, such as the weight of the balance, the diameter of the pivots, the shape of the holes, etc. We also know, as before mentioned, that isochronism can be obtained by means of the shape of the spring.

"Ferdinand Berthoud's Method.—This consists in making the spring wire like the slash of a whip (*en fouet*), or gradually thinner, as the wire recedes from the center. By this means a shorter spring than Le Roy's can be isochronous, and in pocket watches F. Berthoud's method must be resorted to; but the difficulty then arises to make the wire the necessary taper. Le Roy's method is therefore universally employed, owing to the uniformity of the thickness of the wire. Berthoud teaches us also that a spring with many close turns is more suitable for isochronism than another spring of the same length, but with fewer turns and further apart.

"From this it will be seen that the helical or cylindrical spring is more suitable for isochronism than a spring with the coils lying in a plane. We know that in a cylindrical spring all the coils are the same distance from the center, consequently the action of all the coils is uniform, the tension increasing in equal ratio.

"The author has had the opportunity to see at Parkinson & Frodsham's a chronometer with a flat spring, having an elastic stud. By reducing the strength of this elastic stud they believe they can obtain isochronism. For this clever idea we are indebted to Young & Hardy. The first named, at least, is known to have obtained good results with this.

"Isochronism of the pendulum spring does not depend solely upon its length, but also upon its shape; and that more than in one particular; because, not only the taper of the wire, but the form of the spring, plays an important part. A cylindrical spring alters its force, and thereby its isochronal property, when the extreme ends; that is, the upper and lower ends are more or less bent toward the center.

"At Berthoud's and at Breguet's, in Paris, the extreme ends of the spring are not bent, but the whole length is left cylindrical. Isochronism is obtained by weakening the small turns of the spring.

"As the cylindrical spring gains in strength by bending the coils to smaller diameters, so can we, if isochronism so requires it, make the lower coils thinner, and in that way obtain the same result as if the

pper coils were bent nearer to the center and by that means increase their strength.

"One means by which vibrations of unequal extent become isochronous consists in making the balance vibrate large arcs. From F. Berthoud's trial we know that a certain difference in the degrees of large vibrations do not affect this to the same extent as when the vibrations are small.

"With the chronometer escapement it is easy to make the balance vibrate one and a half turns, 450 degrees, or even 480 degrees, by means of which the balance obtains a considerable momentum through which it, at the same time, has the power of better withstanding extreme disturbances."

Why this tendency of the lever escapement to be slow exists in the short vibrations is difficult to explain. There follows after the unlocking of either pallet of this escapement a partial intermission in the energy of the impulse, which is fully restored when the balance spring has reached its quiescent point where the balance spring should begin to show its isochronous property. At the present time most lever watches of fair quality are made at the present time in moderate sizes and carry balances of a diameter of about 0.62 of an inch and of a weight of about eight grains only. It is generally understood that the vibrations of such are isochronized by Breguet balance springs of about 14 or 15 coils and of a diameter of half the diameter of the balance. The theoretical isochronism, according to Mr. Phillips, is pretty well understood by watch repairers who claim to be adjusters. Now, one of the principal conditions of isochronizing different timepieces is the momentum of the balances. According to this condition, small and light balances are isochronized by springs having a small number of coils, while large and heavy balances need a greater number of coils.

The range in the weight or balance prevailing at the present time may be assumed to be between six and 16 grains. The range of the number of coils, by means of which such balances are isochronized, may be assumed for Breguet springs to be from 10 to 20 coils. When using the higher number of coils the thickness of the wire is used in the adjustment of the overcoils for isochronisms. In such cases the size of the collet plays an important part.

Momentum is the force of a body in motion and is equal to the weight of a body in motion multiplied by its velocity. Velocity in a balance is represented by its circumference over a given point of which a given point travels a given distance in a given time. Weight is that contained in its rim. A balance may be said to have more or less momentum, in proportion as it retains force imparted to it by impulsion. If a watch has a balance, with which it has been brought to time, and this balance is changed for one-half its size, it requires to be four times as heavy because its weight is then only half the distance from the center and any given point in its circumference has only half the distance to travel. On the other hand, a balance twice the size would have one-fourth the weight.

In the first case the balance would have twice the momentum as the original one,

because if we multiply the weight by the velocity we have a product twice as great; in the latter case a like operation would give a product half as great as the original balance.

It follows that the smaller and heavier a balance is, the more momentum, and, vice versa, the less momentum it has, always on condition, however, that the balance spring controls equally as to time. It is shown by this argument that isochronism may be modified as much by changing the momentum of the balance as by changing the condition of the balance spring.

The Clock in the Cathedral at Besançon.

THE scientific horologist of the Cathedral of Saint Jean, at Besançon, France, M. Goudey, communicates to *L'Horloger* the accompanying notes and the photograph of this remarkable astronomical clock.

Constructed in 1858 by M. Vérité, maker of public clocks at Beauvais, on orders from

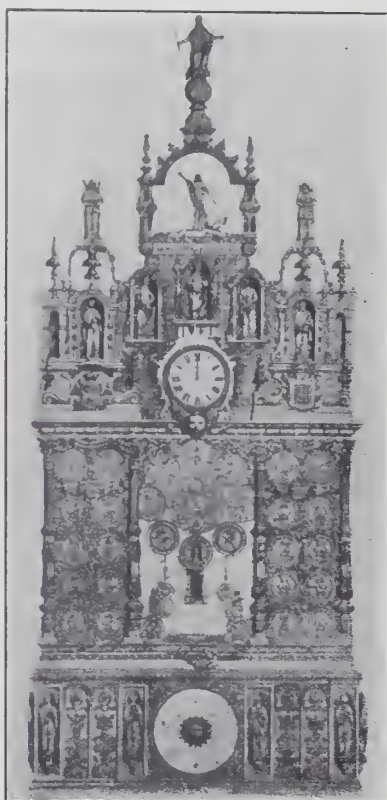

CLOCK IN BESANCON CATHEDRAL.

Cardinal Mathieu, Archbishop of Besançon, this clock, which was out of order, was completely repaired by M. Goudey.

Its dimensions are considerable; it actually measures 19.6 feet in height, 8.2 feet wide and 3.3 feet deep. The eye is first impressed by the large number of dials. Around a central dial, showing the day of the month and the month of the year, are eight small dials indicating the equation of time, the length of the day and the duration of the night, the four seasons, the 12 signs of the zodiac, the days of the week and the signs of the planets that give the name to each day.

Another series of eight dials indicates the second, the hour and the minute when the sun rises, and the hour and the minute at which it sets.

In the intercolumnar space on the right and the left are another series of dials indicating the hour and the minute at the 16 principal points of the globe—Paris, Vienna, Rome, St. Petersburg, New York, Algiers, London, Peking, Jerusalem, Madrid, Constantinople, etc. The hours of the day are gilded and the hours of the night are blue.

In each of the two niches above the armorial bearings of Monsigneur Mathieu and the chapter statuettes representing the 12 apostles appear. At each hour the two statues occupying the niches withdraw of themselves into the interior and two new ones make their appearance to strike the hour at the exact moment. Each statuette holds in its hand a little bell, on which it strikes, with the insignia of its dignity or the instrument of its martyrdom, the required number of strokes.

The two cupolæ surmounting the niches are occupied by the two archangels, St. Michael and St. Gabriel, who strike one the first, the other the second, stroke of each quarter.

Other statues come into action at each hour. At the upper part of the structure is the sepulcher, guarded by soldiers armed with spears. At the moment when the hour of noon strikes the stone of the sepulchre is turned aside and the Christ comes forth, victorious over death, while the soldiers fall, stricken with terror. At three o'clock the scene is reversed—Christ re-enters the tomb, the stone returns and the soldiers resume their watch.

But these are not all the surprises of this complicated clock. On the two lateral sides of the case several seaports are represented as Havre, le Mont-Saint-Michel, Dieppe, Cayenne, la Point-a-Pitre, Saint Hélène, Port Louis, the roadstead of Brest. The waves are in constant motion and the appearance of the skies changes every instant. The clouds pile up, the sea becomes rough, the ships are affected by a rolling motion; then the sky clears and the sea becomes calm.

These movements are not extremely scientific, but the reproduction of the phenomenon of the tides is in every respect exact and takes place on the clock at the exact moment at which it occurs at the seaport.

Another clock for the blind was recently described in *La Nature*. The hours are indicated by movable buttons in relief on the dial. A strong pointer shows the minutes. The blind person passes his fingers over the dial; the button indicating the hour he finds to be depressed, while the position of the hand gives the minutes. The buttons are held by a circular plate beneath the dial, which has at one point on its circumference a notch into which the buttons drop, one after the other, as the plate revolves with the movement of the works. This plate, in fact, serves instead of the ordinary hour hand of a watch. To avoid an undue loss of motive force due to the necessity of rotating the plate, the inventor has furnished it with a little spring of its own so that, although controlled in its rotary movement by the machinery of the watch, its weight does not affect the main movement.

STORE KEEPING DEPARTMENT

That this department shall prove mutually beneficial to our readers, it is desirable that the members of the trade generally communicate with THE JEWELERS' CIRCULAR-WEEKLY regarding any advantageous device or plan which they are utilizing in connection with their business.

Store Illumination an Advancing Science

Suggestions for Securing the Best Results at a Minimum Cost

NEXT to the high quality and reasonable price of his wares, probably nothing is of greater importance than the obtaining of an illumination in the store that will do justice to the stock displayed—a light both brilliant and evenly dispersed, that will heighten the appearance of the gold and silverware, the gems, cut glass, etc., without attracting attention to the source from which the radiation is gained.

In the study of store illumination there

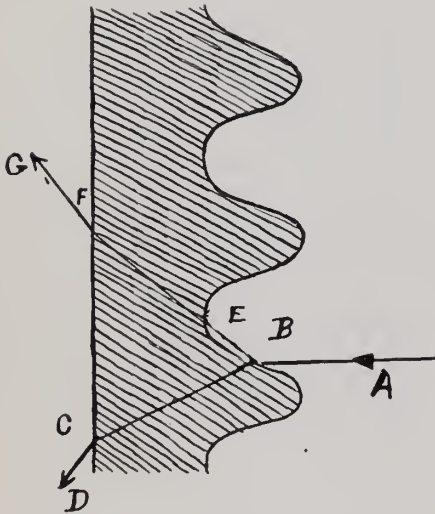

FIG. 1.

are, of course, two phases, distinct and separate, to be gone into. There are dissimilar and often contradictory conditions to be contended with in the lighting of the store by day and by night, the former issue containing the elements of a natural light outside the premises, while the latter has an artificial light within, involving a difference of position as well as a wide difference of qualification.

Sunlight.

Let us start with the former subject—the utilization of Old Sol's rays in lighting up the jeweler's store to the best advantage. Strange to say, this branch of the illumination question is one the least heeded by storekeepers at large, although it involves the solvable problem of obtaining an addi-

tional proportion of something of great value for nothing. The sun's rays are there and kind Providence has granted almost a superabundance of them. Yet the owners of large store fronts usually neglect this great free asset and burn gas or turn on electric lights while a glaring sun is wasting its rays in heating the sidewalk in front.

In the '70's of last century a French genius brought out the Chapuis "reverberators"—large sheets of glass fluted on the outer side and coated with quicksilver on the other side. These reflectors were hinged outside the store or office window so as to permit the regulation of their angle, or tilt, to catch the direct sun rays and deflect them into the store. They proved a boon for a time, and, in Europe, became quite popular. But the dust settled in the ridges of the upper surface and, once coated with mud, their service was at an end unless cleansed and polished. They fell into disfavor, and at the present day few of these useful light projectors are to be seen, or, when found, are wasting their latent powers under a sheet of dust and mud while the inmates of the store or office have resort to gas or electric light. And all the discomfort of heat and injury to sight exists because of neglect to undertake the cleansing of a few feet of glass!

But of recent years a campaign of education in things practical and scientific has been working effects on commercial as well as social conditions. As a consequence, once again, the great advantages of store lighting by refracted sun rays has been preached, and "ribbed," "factory ribbed," "maze" and other forms of refractory glass have come on the market for those desirous of sunlight and healthful rooms free of all cost but the small initial expense of installation.

The late Edward Atkinson, of Boston, after experimenting some time ago with many forms of ribbed and prismatic glass, handed over the outcome of his investigations to Prof. Charles L. Norton, of the Massachusetts Institute of Technology, for a scientific report. The reading of that report is both amusing and interesting. In the professor's exposition of the case we find the following:

"The hopelessness of trying to get some-

thing for nothing—that is, to get a sheet of window glass to throw into a room more light than fell upon it—appeared so plain to me that I made all my preparations to measure not a gain but a loss of light by using Mr. Atkinson's samples. The result of the tests may be briefly stated. In a room 30 feet or more deep we may increase the light from three to 15 times its present effect by using 'factory ribbed' glass instead of plane glass in the upper sash. By using prisms we may, under certain conditions, increase the effective light to 50 times its present strength. The gain in effective light on substituting ribbed glass or prisms for plane glass is much greater when the sky angle is small, as in the case of windows opening upon light shafts or narrow alleys. With the use of prisms a distance of 50 feet from a window has been bette-



FIG. 2.

lighted than when but 20 feet from the same window, fitted with plane glass. 'Ribbed' or 'maze' glass is of very great value in softening the light, especially when windows are directly exposed to the sun, aside from their effectiveness in strengthening the light at distant points. With 'maze' glass the artist may have, in all weathers and in all directions, what is effect a much-desired north light."

George Ilcs, in "Inventors at Work" which book the writer is indebted for much of the information in this article, as well as the illustrations, tells us that: "Prism glass is now manufactured with its outer or street surface ground and polished like plate glass, with its prisms accurate and smooth. In dimensions which may reach 54 by 60 inches it affords surfaces easily kept clean, and transmitting more light than glass held in frames of small divisions. Whence the gain in exchanging plane glass for glass rou-

Storekeeping Department.

ribbed or prismatic? Rays streaming through an ordinary window strike nearby surfaces of wall, ceiling and floor, from which they are reflected in large measure and return through the glass to outer space. Rough, ribbed or prismatic glass throws the rays much further into the room, hence they strike so much larger an area of wall, ceiling and floor that in being reflected gain and again the light is well diffused, and but little is sent forth again into outside space. The form of the glass gives the entering light its most useful direction, so that the new panes serve better than the old. This effect is most striking when

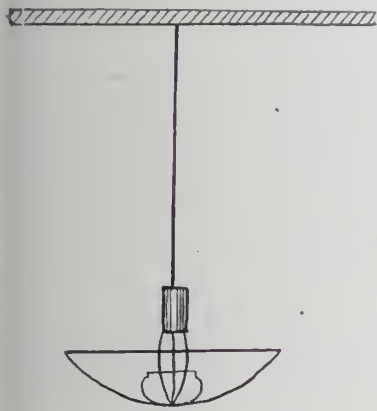

FIG. 3.

prisms are carefully adapted to a particular case in both their angles and their placing." Retail jewelers should pay special attention to the statement quoted of Professor Norton that "factory ribbed" glass is especially effective in the upper sash. Used in the lower divisions of a show window, any other than plane-surfaced glass would, of course, destroy the view of the window display. Used in the upper division of the show front, the irregularity or unevenness of the glass gives an artistic break to the monotonous plate glass plane and produces artistic effects so longed for in "new art" windows. But, above and beyond all, it throws increased and diffused light where most needed, viz., into the furthest corners of the store space.

In Fig. 1 the corrugation of the outer surface of the glass is depicted as diffusing a ray, A, falling horizontally on the corrugated side of the window pane. Split into two rays, B and E, it becomes reflected and then refracted into the paths E F G and B C D. But it will be clearly seen that all rays falling from above also would strike angles of the corrugation and become reflected into the store space; whereas all those rays falling at an angle above 90° (the "critical" angle) to the plane of the glass would be lost by total reflection "if we used glass with plane instead of uneven surfaces. The space at disposal forbids further explanation of this fact, but a glance at the laws of refraction and reflection in any text-book on optics will make the fact clear to those ignorant of that science's rudiments.

Artificial Light.

By a recent computation it has been shown that, in the matter of artificial lighting, for every dollar's worth of commercial illumination purchased the public throws away 60 cents' worth!

Within the last two or three decades immense strides have been made by scientists in reducing loss of energy in the form of heat where light is the product aimed at. Our own Edison in the electric field and Dr. Carl Auer von Welsbach in the realm of light from gas combustion are most prominent.

Taking up the subject of incandescent bulbs, we can look forward to the early advent of great improvement in their constructive quality. For while the Edison

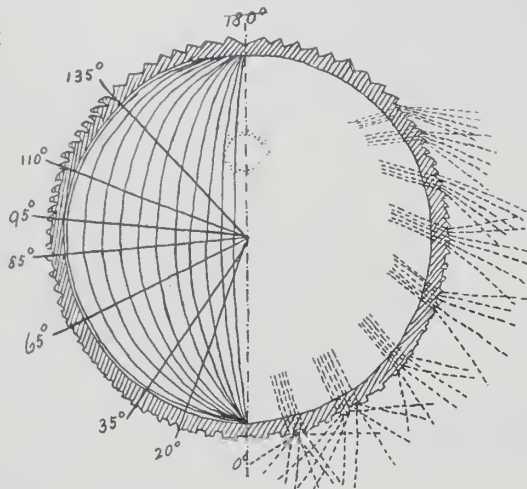

FIG. 4.

bulb has been steadily improved in its qualifications till its present capacity for light is 3.1 candle power for 5.8 watts of current, the "Wizard" himself estimates .11 of a watt the theoretical possibility for that candle power (1/28 part of its present consumption). The General Electric Co.'s carbon filament has an efficiency one-fifth greater than the untreated filament. But the filaments of that rare and expensive metal tantalum and the bulb lamp recently constructed by Dr. Hans Kusel with tungsten filament promise much greater advance

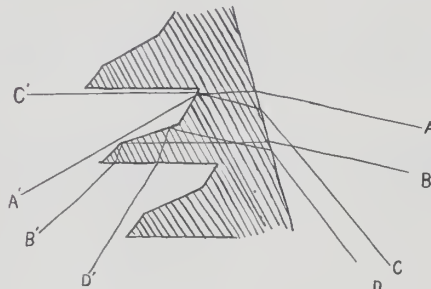

FIG. 5.

both in quality and prolonged life of the instrument. Dr. Kusel declares one watt per candle power only is demanded of the tungsten bulb.

Meanwhile considerable improvements have been made in the method of construction of the glass bulbs of the incandescent lamps. One of the latest forms is that

illustrated in Fig. 2, which has its upper portion silvered so as to contain in a unit both lamp and reflector combined. This permits the luminosity to be projected in any special direction required, thereby reducing loss of the light in unnecessary directions. In cases where it is desired to illuminate the entire surroundings with a gentle diffused light several ridged or corrugated electric bulb shades have been devised which, in their useful work, do not absorb light to the pecuniary loss of the purchaser.

The arc lamp is the cheapest of all commercial illuminants. But its overpowering glare when unsubdued by shades makes it useless for internal use; with shades a loss of radiance, and therefore dollars, occurs. Its most effective value is outdoors, where greater distances render its powerful rays less of a strain to the eye. But a method of utilizing this light source enclosed in limited areas, such as stores, is brought about in the following manner: The arc lamp is inverted—that is to say, the positive carbon's position is reversed by being placed beneath (instead of above) the negative carbon. A good reflector is then placed below the lamp so as to reflect all the rays to the ceiling, which, if painted white, again reflects the rays throughout the entire store in a manner very agreeable to the eye. Fig. 3 gives a rough view of the plan of operation. The continuous current should be used.

Speaking of the diffusion of light rays and its need in the store brings us to a most important invention of M. Blondel and M. Psaroudaski—the Holophane globe. This clever device utilizes to the fullest the optical laws of reflection and refraction. These globes are made in several forms to suit the several requirements. Some are produced to throw practically all rays directly beneath the lamp, others cast all the radiation laterally, others again direct the rays chiefly at an angle of 60°. Fig. 4 displays the plan on which the rays are diverged. On the left hand are noted the degrees at which the prisms are altered to obtain the effect. On the right of the globe section is displayed the direction of the rays as diverted from their natural course. Perhaps the clearest explanation of the *modus operandi* is to quote from "Inventors at Work." "The upper half of each globe is formed into prisms of such angles that, zone by zone, the glass totally reflects impinging rays in just the direction required. The contouring is accurate to the thousandth part of an inch. With this thorough reflection is combined diffusion as thorough, the interior of the globe being shaped as ribs. Thus with the least possible waste the upper half of the source of light is utilized.

In Fig. 5 we have an illustrated definition of the working of some of these prismatic divisions of the Holophane globe. Light ray A is refracted as A'; ray C is refracted as C'. B becomes totally reflected on reaching the extreme edge of the glass and is then refracted, emerging as B'. Similarly D takes its course, emerging as D'.

But, while on the subject of discovery and invention, certain recent researches that must create hope in the storekeeper's breast of great economies to come in the cost of lighting must not be here omitted.

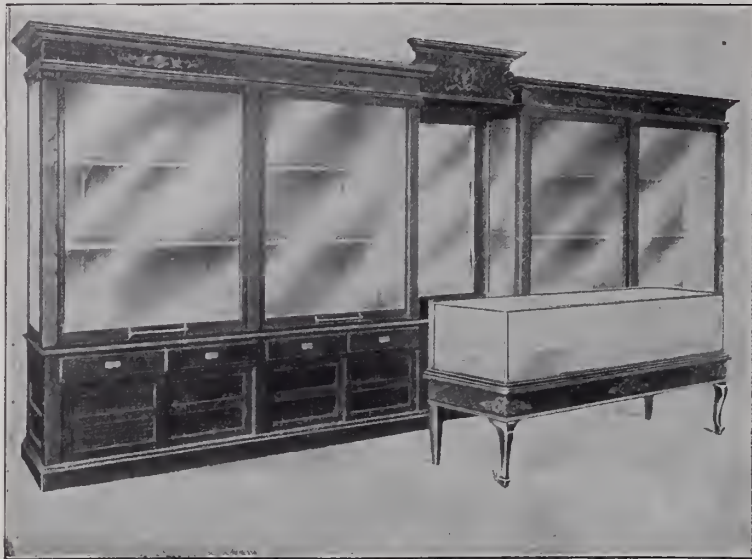

Colonial Wall Case, No. 123. Counter Case and Table, No. 107B.

F. C. JORGESON & CO.
 11 to 17 NORTH ANN STREET, CHICAGO
 MAKERS OF High-Grade Jewelers' Fixtures

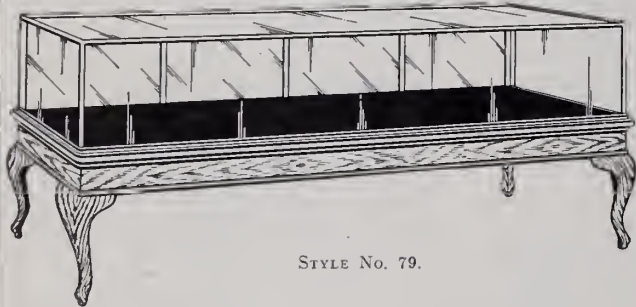

STYLE No. 79.

JEWELERS'
 Store
 Fixtures

Made to order

WADELL SHOW CASE CO.

Near Mt. Elliott, DETROIT, MICH.

Established 1879

Manufacturer of

LOUIS W. HRABA Fine Leather Goods

29 East 19th St., New York

Exclusively for the Jewelry Trade

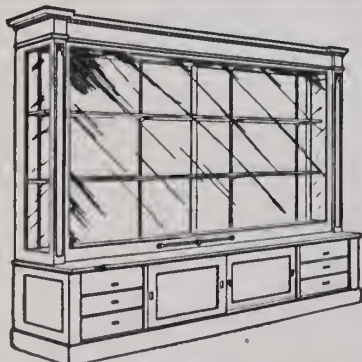

Jewelry Store Fixtures and Show Cases

OUR SPECIALTY

The enlargement of our factory in our new location enables us to quote low prices.

If you need fixtures or show cases let us hear from you. Estimates cheerfully furnished.

ALEXANDER H. REVELL & COMPANY, Rees, Dayton, Eastman and Hawthorne Sts., **CHICAGO, ILL.**

Business Doctor

- Q What your physician does for you when you are sick in body, I can do for you, if your business is ailing.
- Q If you have more stock than you want, if you have old goods that you can't sell in the ordinary course of business, if you want money instead of jewelry—I am the man who "can do things for you."
- Q I have done it for hundreds of others.
- Q I can do it for you
- Q Write me in confidence.
- Q I charge you nothing until after I have achieved results and then only moderately.
- Q It is no expense to you to listen to my plan

HOWARD RINGGOLD

Second Floor

183 E. Madison St. CHICAGO, ILL



ELK TEETH

Unmounted, genuine. Bought of Indians, 10 to 300, as needed, sent on selection to responsible Jewelers at strictly wholesale prices; also

EAGLE, MOUNTAIN LION AND LYNX CLAWS.

L. W. STILWELL,

DEADWOOD, SOUTH DAKOTA.

Wholesaler of Sioux Indian Bead-Work and Curio Supply Jobber.

PATENTS

obtained on inventions and designs. Trade-marks, prints and labels registered.

R. W. BISHOP,

ATTORNEY-AT-LAW,

908 G Street N.W., Washington, D.C.

Storekeeping Department.

By impregnating with salts the arc-light carbons what are known as "flaming" or "luminous" arcs are produced, giving greatly enhanced luminosity. By this means the arc itself and not, as formerly the glowing carbon, becomes the light source. The salts (of the calcium group) become volatile with the arc's intense heat and form gases or vapors. And these vapors produce a path of greatly reduced resistance as compared with air, thereby permitting the carbon electrodes to be drawn further apart. The consequent economy is revolutionary. A single candle power is claimed to be available at a cost of .353 watt as compared with 1.78 utilizing the present enclosed arc lamp. Candle power, in other words, produced at one-fifth of present prices!

But even the Welsbach lamp has made recent advances in effectiveness, for the gas mantles, formerly woven, are now knitted, greatly to their improvement.

Unfortunately for retail jewelers established in the smaller towns, where illuminating gas or electricity are not obtainable, no mantle has yet been made available for petroleum lamps. But even in such position there is hope for early release from such conditions, now that the law permits the free manufacture and sale of alcohol after "denaturizing." For with a Boivin burner and a Welsbach mantle 30.35 candle power for 57 hours and five minutes is obtained from the consumption of a single gallon of alcohol; that is to say, twice as much light as a round-wick Miller lamp and central draft consuming one gallon of petroleum. With alcohol at 25 cents per gallon, or less, the kerosene-lighted store is likely soon to become a dark memory.

Speaking of mantles reminds one of the weak point in the Welsbach lamp—the rather sight-trying green tinge of its rays. The human eye has through countless generations developed a condition that is best suited by light having its colored rays in the same proportion as those emanating from our sun. There are many Welsbach lamp patrons who have not yet learned that by using a pink shade over the mantle the eye is eased and nervous strain reduced.

And now a few words on economies easy of practice but rarely used. As all are aware, the metallic oxide mantles, after a period more or less brief, show fissures in the textile and emit carbon fumes at a loss of light rays. But very few appear to be aware that the filament of the electric bulb also becomes defective and wasteful some time before it breaks and enforces its rejection for a new one. In stores that are sufficiently capacious to necessitate a fairly large number of lights a considerable economy might be practiced.

The mantle and the incandescent bulb furnish a maximum of light for a minimum of cost only during a certain time. It should be carefully calculated how long the "life" of the special mantle or bulb used is burning to advantage. Some one of the employes should be deputed to learn the practical limitations of the lamp in use and renew them regularly at the date when deterioration reaches what is known as the "losing" stage.

This not only entails a reduction in expense, but maintains the highest standard of illumination.

C. W. C.

February Business Getting.

WHAT schemes have you employed to draw trade during the dull month of February? Look over your old plan books and bring out your old advertising matter for that month of other years. Are you proud of the effort you made as shown by those records? Are you satisfied with the results that accrued from those efforts? If you are, make up your mind that this year shall show greater results than any that has gone before. But if not, now is the time to roll up your sleeves and go right after the business that has eluded your grasp in the past.

And what are you going to do to get your share, and a little more than your share, of trade from a thoughtless public? Think, scheme, revolve in your mind the best possible means of securing this, then act—do something. The great difficulty with so many, the stumbling block that hinders the progress of otherwise capable and energetic business men, is that they lack decision—their plans never materialize. They expend unlimited mental force in laying the foundation of some elaborate trade-winning scheme, but they lack the push to carry out their well-thought-out plans.

There are those who consider and weigh the merits of many plans, but cannot decide upon any as exactly suited to their needs, so they hesitate and wait for a better inspiration. While waiting their own enthusiasm dies out, the opportunity slips past and they end by doing nothing. Think and plan, but also decide and do. Suppose your idea doesn't fully satisfy you; put it into execution anyway, if it's the best you can think of, rather than wait for just the right thing to suggest itself to you. It is indecision and waiting that eats up time, and time to you is money.

M. C. G.

A Distinction.

"JOHN, dear," said the wife of his bosom, as she was about to start downtown, "can you let me have a little pin money this week?"

"About how much?" queried her hubby.

"Oh, I guess \$500 will do," she replied, rather nonchalantly.

"Great guns!" he exclaimed. "Five hundred dollars for pin money? Why, I can buy a cartload of pins for \$5."

"But not diamond pins, dear," calmly rejoined the alleged better half of the matrimonial combine.—*Ex.*

In new lines of goods is where the profits lie. The old stand-bys that every dealer keeps have the prices all cut to pieces on them. Get the new things ahead of the other fellows and make money on them.

Frequent change of the arrangement of your show cases gives the effect of new goods received. The same old arrangement month in and month out, no matter how many new goods, looks like the same old stock.—*Printers Ink.*

"Stationery Selling by Retail Jewelers" will be concluded next week.

How to Meet the Competition of the Mail Order House.

(Continued from issue of Jan. 15.)

WHEN you write up the next advertisement for your local paper, suppose you make a change in your regular copy, and just advertise only a few things, drawing attention to the fact that your prices on these articles are just as those quoted by mail-order houses. Say that you have the goods right there at home, where one can see and feel them, and one does not have to take your word for the quality, but one's own judgment can be used.

Follow this up every week, using a few lines in each advertisement calling attention to the poor judgment a man shows who spends his money for goods without knowing what the goods will look like on arrival. It will not be long before you will be able to see a change in your favor. Give the public to understand that you think their judgment is good, if they can see what they are buying.

In showing up the poor policy of buying goods by catalogue use as simple illustrations as you can think of. For instance, ask if any one would hand a stranger 50 cents to pay for a pocket knife which he had just claimed to have purchased as a bargain, and which he claimed was worth even more, although he had never tried it. And although he kept the knife in his pocket, out of sight. Then say to them, this is exactly what is done by people who order goods from a mail-order house.

Constantly harp on the fact that you are able to show the goods, and that you let them both see and feel them so people will know exactly what they are spending their money for; that they are not being misled by a skilfully worded description must certainly have its effect upon those who read your advertisements.

Mail-order catalogues cunningly act so suggestively on the people who read them that you must yourself put together something which will kill the effect of that suggestion.

Do not make up your mind that there is nothing in suggestion. You will make a big mistake if you do. Why do catalogue houses list well-known brands at a low price in small space with slight description, and then, on the same page, list unknown goods so as to appear just as good? They give these latter a big space and full description and make the price a shade lower than the well-known brand. All this suggests to the reader, thinking they will save money on mail orders, that they sell all goods very cheap, but that the unknown brand (though just as good as the known brand) has no extra charge made for its name. The result is a large percentage of sales of the unknown brand, and at a good profit. You know this to be a fact, so do not decide off-hand that there is nothing in suggestion. It is a science you must cultivate, if you are to beat the mail-order houses at their own game. And you can begin at no better point than the suggestion that every person should see the goods before he pays his money down. Suggest this thought, then keep on suggesting it, until every one who reads your ads will wonder how they could have been silly enough to have ordered goods without knowing what they really were.

(To be continued.)

The Lady Racine

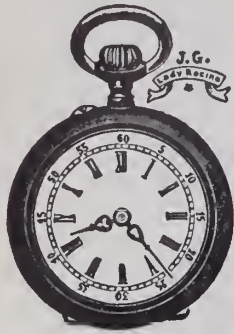

Positively the BEST chatelaine watch in the market.

Machine Made

10, 11, 12 and 13 Line; Cylinders and Levers; cased in Nickel, Gun Metal, Silver and Gold.

Material on Hand.

Write for prices.

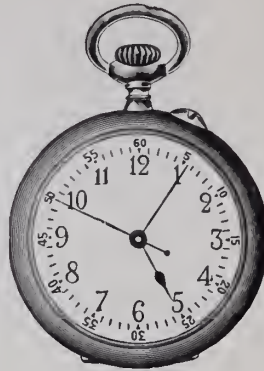

Lady Racine Nurse Watch.

JULES RACINE & CO.,

103 STATE ST., CHICAGO. SOLE AGENTS 37 MAIDEN LANE NEW YORK.

For Sale by all Jobbers

Trade-Mark.



Trade-Mark.

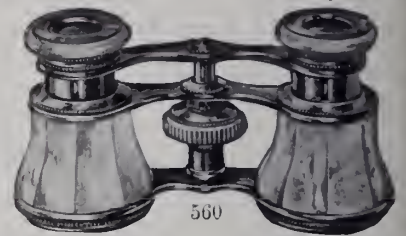

COLMONT OPERA and FIELD GLASSES

have been recognized by Opticians who really wanted a good article without paying too high a price.

With Colmont Glasses
You Have a Guarantee

The name STANDS for honesty and uniformity of construction, fairness of price.

For your own advantage, investigate the "COLMONT" line at your jobber's.

SUSSFELD, LORSCH & CO.

Importers

NEW YORK

PARIS

IF IT'S A



TRADE MARK REGISTERED

IT'S STANDARD

The Highest in Quality!
The Finest in Finish
The Best in Workmanship



ROY WATCH CASE CO.

21-23 Maiden Lane, New York City

SAN FRANCISCO, CAL.

LONDON, ENG.



Every Jeweler

has lots of odd stones and out-of-date jewels that can be made into the latest styles, to sell at a profit. Send to

Henry C. Haskell, 293 7th Ave., New York

who will gladly submit SPECIAL DESIGNS with estimates; you incur no expense if not entirely satisfactory. CORRESPONDENCE INVITED.

ESTABLISHED 1879



S. BORGZINNER CO.

MANUFACTURERS and IMPORTERS

82 and 84 Nassau St.
NEW YORK

CHARLES M. PRIOR, Designer

We have ready many new designs. Call or write. Etching is more popular than ever and we do it in the finest style.

'Phone 1639 Gramercy

24-26 East 21st St., NEW YORK

Mechanical Window Displays

Constructed With a View to Enhancing the Attractiveness of the Jeweler's Show Window

By Otto Jonas

A Snow-Storm Display.

FEW cents' worth of white tissue paper will serve our purpose for this window. Frequent experiments have shown that for effective snow this paper should be about one-half an inch square. Crimp such paper just enough to separate it from others. This can be easily and quickly done by dropping all the papers into a large box and after first shaking them well, going through the motion of washing your hands in the paper, alternating this with occasional shake of the box. Secure a wooden box sufficiently large to hold your fan, which may have either 10- or 16-inch blades. If your fan has blades of either size the box could be like

display will attract a large crowd and excite curiosity. Throw in an extra handful of cut paper at intervals and remove fragments that have become hard twisted and do not float nicely. Fig. D shows the miniature snow storm as a central figure for a window display.

Remove the plate from your motor and clean out the accumulation of paper whenever needed, or else papers will gather in the fan and clog it. Some fans may require clearing out once a day; others but once a week.

Be careful that your wiring inside the box is well insulated, and be sure to disconnect the fan from the power before starting this work.

The Hustler of To-Day.

THE word "hustler" has a broad significance, all its own, that is not quite covered by any other term. It is a word that is particularly popular in business and well adapted to the commercial spirit of the times.

The hustler is the man, who though environment and opportunity have given him but a sorry start, pushes forward to the front ranks among men; who is undaunted by adverse circumstances, and knows no insurmountable obstacles. He is one who gathers from his own errors and failures the experience that is to become a firm foundation for future business success.

While the masses around him are drifting aimlessly along, through a mediocre career, he is gathering together the equipment necessary to help him onward and upward to the goal toward which he has set his face.

In the earlier stages of his develop-

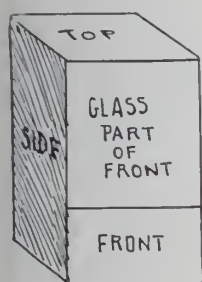

Fig. A.

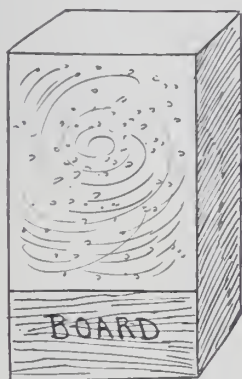

Fig. C.

FRONT WITH FAN OPERATING.

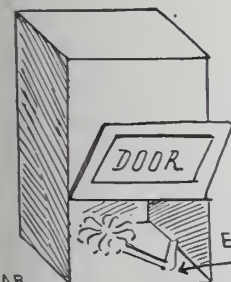
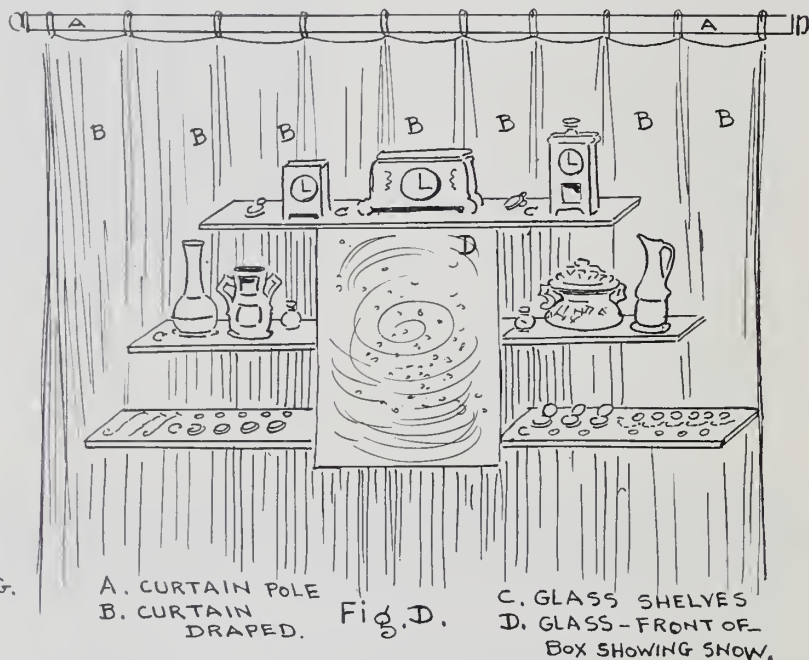

Fig. B.

DOOR OPEN WITH FAN



A. CURTAIN POLE
B. CURTAIN DRAPED.

Fig. D.

C. GLASS SHELVES
D. GLASS-FRONT OF BOX SHOWING SNOW.

DIAGRAMS SHOWING HOW TO CONSTRUCT APPARATUS ESSENTIAL FOR THE "SNOW-STORM" WINDOW DISPLAY.

one shown in Fig. A. The box will have to be practically air-tight and cracks may be covered with paper strips, carefully pasted on. Part of the front of the box is to be of glass, but a comparatively small piece of glass will suffice as the lower part of the front of the box will have to remain to prevent the fan from showing.

Build a little door or arrange a removable section in back of the box, which must be of sufficient size to permit the insertion and withdrawal of the fan. The inside of the box is to be lined with dark paper, which must be pasted on smoothly. When complete, your cabinet will look like Figs. B and C.

When all is finished, lay your fan face upward, in the bottom of the box. Throw two or three handfuls of paper into the box and start the fan. The paper will blow, twist and whirl around in the box, resembling a snow storm, and like any moving

If one is skillful enough to hide the box entirely, people will wonder how the paper can circulate in the center of the window without scattering. The glass is practically invisible when kept perfectly clean.

By means of a curtain (Fig. D), draped so as to conceal all of the window box from the public excepting the glass part (which should be exposed), and then by arranging the display of goods on shelves as shown, these to be placed in front of the drapery, a most effective exhibit can be produced.

Like all moving displays controlled by electric fans, this may require some experimenting before the affair is properly adjusted. It had best be completed, as far as the mechanical feature is concerned, and tested outside of the window first.

Use a curtain of some dark material so that the contrast will be striking when seen in connection with the moving snow.

ment the hustler is the man sought after by employers, while in riper years he commands the respect of competitors naturally accorded the progressive leaders of the day.

Ambition, push, enterprise, adaptability, alertness and untiring energy all go into the make-up of the real hustler. The time has long since gone by when hustling merely conveyed the idea of high speed and bustling energy; it invariably means well-directed energy. It is a characteristic of the man to whom minutes are precious, but who so systematizes his work as to admit of the least possible waste of time. In fact, the hustler is a man whom any one may be proud to shake by the hand, for he is distinctly a man of action, a man that does things.

Tact, hard work and advertising bring success to the enterprising.

Original Window Displays for the Jeweler

Designed Expressly for The Jewelers' Circular-Weekly

For the Valentine Season

HERE are two original window displays designed expressly with a view to attracting attention to the retail jewelers' stock during the season of valentine-giving and the week of Washington's Birthday.

St. Valentine's Day, which follows closely upon the holiday season, has recently been made the occasion for very extensive advertising by many jewelers. Many firms supplement their regular newspaper advertising with handsomely printed folders and pamphlets describing the origin of the custom of sending valentines and illustrating dainty little trinkets calculated to interest lovers and sweethearts.

In the valentine display the boxes illustrated herewith should contain rings of all kinds, engagement and wedding rings being especially prominent. Brooches, scarfpins, heart-shaped lockets, friendship rings, etc., etc., may also be shown in this display with good results. Choice gifts of silverware are arranged in boxes in the rear.

The background decoration should be made preferably of white hearts of any suitable material. These hearts are suspended by means of silk ribbons. Those just above the silverware may be pierced by fine hatpins in place of the usual Cupid's arrow. A band of white ribbon connects the three larger hearts.

A Display for Washington's Birthday.

The effect of window displays, particularly those suggesting patriotism, is more beneficial than will seem at first thought. The public is always impressed with the

mediate pecuniary advantage which they may bring. This display for Washington's Birthday is simple in arrangement, but, nevertheless, if carried out faithfully, will show up most attractively.

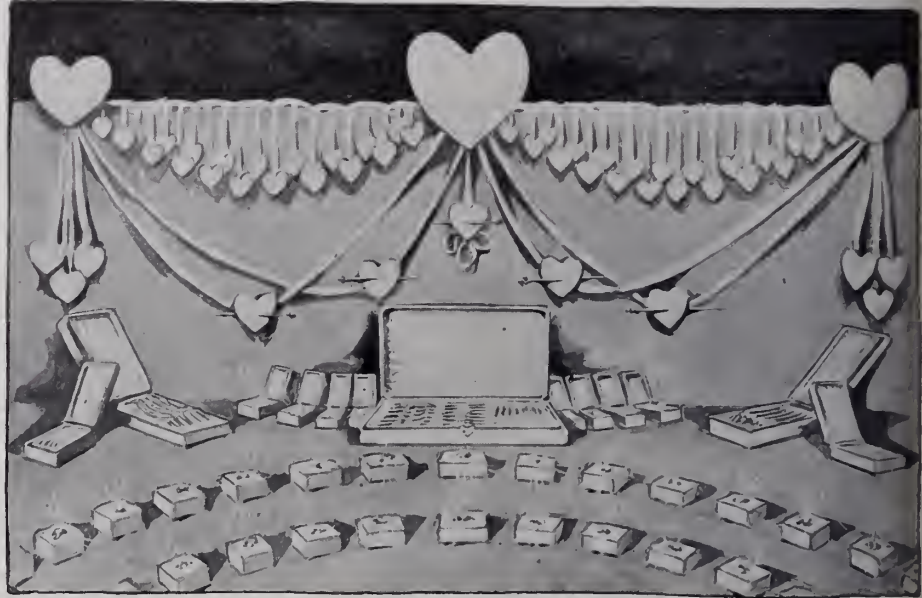

A DAINY DISPLAY FOR THE VALENTINE SEASON.

In the central background is suspended a flag-draped picture of General Washington, surmounted by a wreath. Festoons of small flags should be arranged as illustrated in



PATRIOTIC DISPLAY FOR WASHINGTON'S BIRTHDAY.

establishment which seems to keep abreast of the times and is conversant with current topics and events of national interest. Hence, the importance of the regular so-called patriotic displays, aside from any im-

the drawing. Each box of jewelry is also set off by a tiny reproduction of Old Glory.

The ornamental effect in the foreground may be formed of watches and chains. Small flags surround the choicest brooch.

Start Your Own Rogues' Gallery.

IT is often a source of wonder that the retail jeweler is so great a victim of thieves. The fact of the high value and portable quality of his goods necessarily tempts the criminal mind to consider the owner of gems a good source from which to draw. But, this fact being so obvious, it often appears to the thinker that the retailer uses too little precaution against such a steady attack.

It has been ever a strong point with THE

CIRCULAR-WEEKLY to aid the jewelry trade in fighting against thieves. To this end, among other lines of action, much energy and time and money are spent in obtaining all the data available concerning thefts in the trade, and, where possible, to reproduce a photograph of the criminal. Nothing assists so much in squelching the career of a thief as the publishing of his likeness by the press. But unfortunately many members of the trade do not retain very long a file of their trade journal. And with the relegation of the issue containing a pictorial illustration of a jewel thief's physiognomy to the waste paper basket, the good work is largely lost.

Supposing the retailer were to purchase a blank book and therein paste the pictures and story of the thieves appearing from time to time in the columns of his trade paper. Committing the features to memory, the retailer could keep that "rogues' gallery" under his counter for quick reference when he sees a suspicious character entering his store whose visage looks familiar.

One of the most valuable aids to the police force in keeping down the criminal element is their "rogues' gallery," as everybody is well aware. But the thief who starts pilfering transactions in a jewelry store will usually maintain that line of action in future nefarious work, so that a large range of likenesses of jewelry thieves immediately available for the doubtful jeweler should prove a lasting benefit that, in the end, will well repay him for the little time and trouble attending the getting up of a jewelers' amateur "rogues' gallery."

Storekeeping Department.

Representative Retail Jewelry Store of Lima, O.

ONE of the noteworthy retail jewelry stores of Lima, O., is that of Robert MacDonald. This store measures 24 by 80 feet. The jewelry store proper is by 60 feet, an optical and clock room occupying the remaining space. The front of the establishment is trimmed with birch, the ceiling being handsomely paneled and ludded with 24 electric globes. By a clever arrangement all undesirable reflections are eliminated.

The furnishings are of mahogany and the show cases of plate glass. There are three cases on each side of the store divided by a mirror four feet wide and made in the form of a settee. These cases are lined with green billiard cloth. Each cabinet has its own lighting scheme. A rear show case is 10 feet long and 28 inches deep and is made of plate glass, with mirror lining.

The regular floor cases are all of plate glass 10 feet long. The main horseshoe case is 10 feet by eight feet. The floor of this store is of Mosaic tiling, the color scheme being blue and white. The ceiling is attractively frescoed in blue with a stucco decoration in old ivory. The electric fixtures are made of burnished brass and are of the Colonial style. All the display cases are illuminated with 105 globes of eight candle-power each. The draperies in this establishment are silk velvet velour. Mr. MacDonald built up the firm of the MacDonald Jewelry Co., of the same place, at sold out in April, of last year.

The merchant who says the way he's always done is a good enough way for him is like the fellow who is trying to win races yet driving his trotter in front of a big-wheeled, steel-tired sulky.

One of the best ways of selling good goods is to have the cheap ones; show them first, then come out with the good ones and the difference between the grades, bearing in mind on quality and guarantee.—E.V.

Knowing One's Customers.

IT is not necessary to make social friends of your customers, but make of them close business acquaintances, says the *General Merchants' Review*.

Some men in business never make any special effort to become personally acquainted with the people of the community in which they live and try to do business. They somehow seem to feel that their position in the community is an important one and, therefore, they must be so dignified as to not show too much familiarity with the masses of the people. This may not be what they think, but it is what they act, hence the result is the same.

The merchant should take lessons from the political candidates who solicit votes by using all their arts and powers to create a favorable impression with the people. The office-seeker may by nature be a cold-blooded individual, but he has business sense enough to know that if he is to find favor with the voters he must cultivate their acquaintance and, if possible, create the impression that he is worthy of the office he seeks and that if elected he will serve the people faithfully.

What would one think of a candidate for office who was not well known to the voters of the district he hoped to carry who would simply announce in the papers that he was a candidate and then sit down in his office and wait for election day? Suppose that some of the voters who had never known him, except possibly by sight, should call at his office and he should reluctantly lay down his paper and, looking at them in a manner that indicated he had been disturbed, should say to the callers: "Well, what's on your mind to-day?" We have all seen men in business receive callers in just such a manner, especially when the callers were strangers and the merchant wasn't sure whether they came to buy goods or to get his contribution to a public enterprise or a charity subscription.

Nothing throws a chill over the prospective buyer quicker than to enter a place of business to see what he can do and be re-

ceived in the manner described. It should be the constant study of the man who seeks trade from the public as to how he can become better acquainted with every one in the community. He should study to please, not only in the goods he sells, but in every way. The man who always has a cordial greeting for all who enter his place will find that people will go out of their way to do business with him.

The Way of the Enterprising.

DURING the holiday season Hugo Beil, Lawrence, Mass., sent out to a select mailing list a number of circulars four and one-quarter inches wide by seven and one-half inches long, showing on one side an interior view of his retail jewelry store, together with appropriate advertising matter, and on the reverse side an advertisement calling attention to his optical department and workshop. The store has been established for the past 50 years. It is located at the corner of Essex and Appleton Sts.

A ferris wheel exhibited in the store of F. B. Smith, Montrose, Pa., during the holiday season, attracted a great deal of attention. The wheel was made of copper wire interwoven and interlaced in such a manner as to give it a substantial appearance. These wires were covered with tinsel foil. The wheel was about three feet in diameter and contained a display of all kinds of jewelry.

Brock & Feagans, on the occasion of the opening of their new establishment in Los Angeles, Cal., Nov. 11-12 last, distributed handsomely engraved announcements seven and one-quarter inches wide by nine and one-half inches high. The firm name and address were not printed in conventional fashion but embossed in ecclesiastic lettering by means of a special process, no ink being used at all.

The Arkansas Diamond Mining Co. has been incorporated, with a capital stock of \$100,000, to continue the development work begun by Sam W. Reyburn in Polk County, Ark.



AN EXTERIOR AND AN INTERIOR VIEW OF THE ATTRACTIVELY FURNISHED STORE OF R. D. MACDONALD, LIMA, O.



RETAIL JEWELERS ADVERTISING

Vigorous Advertising of Diamonds Marks the Opening of the New Year

MANY retail jewelers began their advertising campaign this year by making a special exploitation of diamonds, resuming their usual arguments to show the advisability of buying diamonds as an investment proposition. That this form of advertising is probably the most judicious

on the increasing expense attendant upon the work of successful mining for diamonds. The suggestion was offered, in fact, that there was a possibility that the stones would increase in price at no distant date.

Here is a chance for the enterprising ad-

vertiser investigation and also laid special emphasis on the denial.

The retail jeweler cannot impress too strongly upon the public's mind this positive fact that diamonds will continue to preserve their gradually increasing value, and this impression can best be made by good, strong newspaper advertising. The advertisements shown herewith were all used before this authoritative denial was given publicity, and that undoubtedly accounts for the absence in them of any reference to the matter. Even in the face of this it is significant that all of these advertisers of diamonds, except one—namely, Arthur M. Field Co., Asheville, N. C.—do not express any urgent anxiety to get rid of any surplus diamond stock.

It is the belief of conservative diamond dealers, and probably a well-founded one, that diamonds, owing to their very nature, can never be purchased at any appreciable disadvantage. In a word, it is believed, and

DIAMONDS

**Carter-Allen's
Name On the Box**

Is a delicate tribute to the recipient of your gift, signifying that nothing short of an acknowledged BEST would suffice for her or him, and that the finest both in point of quality and artistic merit is contained in the box.

We Cordially Welcome a Comparison of Our Prices

Carter-Allen Jewelry Co.

**DIAMONDS
WATCHES
NOVELTIES**

CUT GLASS SILVERWARE

THE Diamond Department of Arthur M. Field Co. are still maintaining the prices of these years ago in order to reduce the very large stock of Diamonds on hand.

BEAUTIFUL DESIGNS WELL EXECUTED AT REASONABLE PRICES

ARTHUR M. FIELD CO.

COR. PATTON AVE. & CHURCH ST.

Diamonds

For the annual January Diamond Sale our stock offers an exceptional choice from desirable designs in

Rings, Brooches, Pendants

and besides there are price advantages. A comparison is invited.

C. E. Gifford & Co.

40 NORTH MAIN STREET
BRODNAX

Diamonds

You will be interested in our showing of Diamond Rings, Diamond Brooches, Diamond Bracelets, Diamond Lockets, Diamond Necklaces, Diamond Earrings, the gold ink and the red translucent ink, and the red translucent ink. The moderate price is made to turn them over quickly.

THE J. M. WHITNEY CO.
JEWELLERS

FRENCH
MARBLE
CLOCKS

We have a number of these beautiful clocks, handsome and reliable, that we can sell as low as \$19 each. All \$19 we have several about 25 inches wide and 14 inches high, that should not be missed.

Wanless & Co.,
FINE JEWELLERS,
Established 1849
188 Yonge Street

If You Contemplate
Investing in
DIAMONDS.

We would like to Show you our stock and quote our prices.

All stones of finest quality and guaranteed.

"The Old Jewelry Shop."
The Porter & Dyson
54 MAIN STREET.

ESTABLISHED 1849.

Make a Good
Start

A fine Diamond to begin the year with would be a profitable purchase and a profitable investment.

A Diamond bought here will be worth considerable more next year. We have a large stock of first water gems, many of which have been held as collateral until recently. They were bought when prices were down. Take the hint.

DILLON CO.

1223 MARKET STREET.

Save Your
Earnings By Buying
A Diamond.

Are you satisfied with the disposition you made of your surplus earnings during the past year?

If you haven't anything to show for the money you need, don't start this plan, for you are protected, should you find details about our plans. The booklet and large jewelry items will be mailed you at our expense promptly upon receipt of your request.

Geo. T. Brodnax, Inc.

Diamond Merchants,
Main St.,
Memphis, Tenn.

DOUBTLESS
YOU KNOW

That we can send you the greatest variety of the most beautiful and valuable gifts that we have ever offered to the public.

New Year's
Gifts

For the many—the Jewels, Rings, the Jewelry, Pendants, the Gold and Silver, the what appeals to the taste of the consumer.

Cat Glass Room.
Johnston Bros.
Jewellers,
483 St. Catherine
West.

DIAMOND AND OTHER ADVERTISEMENTS USED DURING THE FIRST MONTH OF 1908.

cannot be gainsaid, especially in view of recent unfounded rumors that the price of diamonds was about to depreciate.

These rumors were vigorously denied later and logical reasons were given by well-known diamond importers, and, in fact, by the diamond controlling Syndicate in London itself, why the price of these precious stones would not decrease. The general reasons are economical ones, based not only on the law of supply and demand, but also

vertiser to strengthen his advertising argument in favor of the early purchase of diamonds. Among clippings denying these reports that might be used to good advantage is one which might be culled from the issue of THE CIRCULAR-WEEKLY of Jan. 15. This was a direct denial of the rumored depression in diamond values by Leopold Stern, who had been authorized to speak in behalf of the Syndicate. Several of the daily papers, too, used this as a tip for

proper advertising can make the public see, that diamonds have a quasi-money value, negotiable at all times without question. This advertisement of the Field Co. was used in a space of six inches, double column.

The little advertisement calling attention to French marble clocks, by J. Wanless & Co., Toronto, Ont., occupied a space of 3 1/2 inches, single column. This is a small ad., but is typographically attractive and very

Retail Advertising Department.

well written. Prices, too, are quoted. There is a mark of originality about the advertisement of the Carter-Allen Jewelry Co., Shreveport, La. The electrotype of the three-stone diamond ring, with the word "Diamonds" surmounting it, makes an attractive border. The main purpose of this ad. is evidently to impress upon the reader's mind the exceptional quality of the stock carried by the concern. This fact is emphasized in rather an original manner.

C. E. Gifford & Co., Fall River, Mass., used the advertisement on the right of this in a space of 4¾ inches, double column. Their ad. is simply an announcement of a January diamond sale.

There is a touch of dignity in the announcement used by the J. M. Whitney Co., Victoria, B. C. The original occupied a space of 2¾ inches, single column.

The design of the border used by Johnstons Bros., Montreal, Que., is a unique combination of art, including the art nouveau style and more modern motifs. The Cupid seated on the engagement ring at the top will make a timely accompaniment to the advertising of engagement rings, which, by the way, might also have been advertised as New Year's gifts.

An unrefutable business proposition is contained in the advertisement of Geo. T. Brodnax, Inc., Memphis, Tenn. This is an ad. which will undoubtedly appeal to a reader as strongly, if not more so, than the advertisement of a savings bank offering a generous interest for the use of the prospective depositor's money.

The Dillon Co., Wheeling, W. Va., uses an odd border design, into which the artist has interpolated the firm's "Sign of the Clock" in a clever manner. The concern's street clock for several years has been made the subject of a well-chosen catch phrase which has proved valuable in giving an identity and individuality to the advertisements. "Make a Good Start" is a catchy phrase and introduced a convincingly written argument.

The Porter & Dyson Co., New Britain, Conn., in a space of five inches, double column, merely invites prospective diamond purchasers to visit its establishment and inspect the diamond stock.

C. R. McLachlan, Winnipeg, Man., has an advertisement which is cleverly designed, the jeweler's building being partly illustrated in the border. This ad. was used in a space of 4¼ inches, single column.

R. F. N.

Business Philosophy

ORIGINATE your own plans and carry them out. You may be able to copy your neighbor's plans, but it is very doubtful if you can copy his success.

Can you teach others things which you yourself do not know? That is why the man at the head of the business should know how to do the things at its foot.

Worry has spoiled a good many otherwise first-class business men. If a man would succeed, he should learn to keep out of things which cause fruitless worry.—*Printers' Ink.*

Easter Advertising Suggestions for the Retail Jeweler

Written and Prepared Expressly for the Jewelers' Circular-Weekly by "R. F. N."

AS a gift-giving season Easter has become second only to Christmas. Thus far the jewelry stores have had the bulk of the business along this line because they are always prepared for the demand, and other lines of trade have been slow in awakening to the fact that the Easter business is worth going after.

While one must be careful not to spend more money in advertising for the Easter business than that business will warrant, yet an early start in this kind of publicity and a persistence in suggestion in the less expensive ways will pay remarkably well.

An investment in a few Easter lilies for use in the windows will pay, and many stores make it a point to give flower souvenirs on the Saturday before Easter Sunday.

An Easter booklet or folder telling about the things you have for Easter-giving is good advertising. Put a cover on it printed in purple, and if a booklet tie it with purple cord instead of stapling it.

This, of course, is about the most expensive thing you can do if done at all elaborately. Next to a folder a good thing to mail is a high-grade card artistically



ATTRACTIVE FOLDERS AND BOOKLETS FOR THE EASTER AND VALENTINE SEASONS.

The dealer who uses the daily papers should fill his space with Easter talks for a couple of weeks before the day. The dealer who uses only the weeklies should begin at least three weeks in advance.

These talks should not only embody suggestions for gifts, but should bear strongly upon the popularity of gift-giving at that time, taking the attitude that, "of course, you are going to make some one a present, the only question is, What shall it be?"

Gifts of an ecclesiastical nature are particularly appropriate at this time and should be exploited well. Gold crosses, rosaries, breviaries, gold or silver mounted prayer books, etc., etc., are among the articles that are in demand.

List these in your advertising and give full descriptions and prices. Display them in windows and show cases. Take special pains to make the Easter windows attractive with purple decorations and other timely aids.

printed and calling attention to your Easter display and perhaps mentioning some one particularly attractive line that you know is likely to interest the public. Mail in an envelope.

An inexpensive ad. is a folder bought early and used for a month before Easter to insert in all packages going out of the store. This will serve as a reminder that Easter is coming and may contain special offers that will bring trade.

The makers of artificial flowers for window displays have a good line of Easter display goods, and a violet or an apple blossom window need cost very little money.

An attractive window can be made by putting a border of apple blossom crepe paper all the way around the glass, making a frame, and using strips of the same for a background with a few branches of artificial apple blossoms in a big vase in the center.

The violet color scheme can be made perfect by using violet crepe tissue paper in the

Retail Advertising Department.

solid color and having a strong light at night to make it show up well.

Less expensive than a booklet to mail and less work to get out is an artistic souvenir post card to send to your patrons announcing an Easter sale. The card should not be gaudy or cheap in any way, but rather rich in design and plain. It can contain little more than an announcement and, of course, its value is in proportion to the space available. It costs just as much postage to mail a card as it does to mail something better. The postage expense is the large item, and it is well to get as much value for it as possible.

It will pay a jeweler to get out a booklet three or four times a year for mailing purposes, and one of those times should be previous to the Easter season. These booklets can be made attractive enough to appeal to the best class of trade and to be saved for reference. They are the nearest thing to a small catalogue, and are, next to the

suitable shapes in the regular stock. Solid gold brooches from \$—— up.

Gifts for ladies, gentlemen, and for the little folks.

Usher and brides' presents and wedding favors. Another style of folder might consist of two or more pages containing illustrations of artistic Easter jewelry, such as heart-shaped lockets, la Valliere chains, brooches having as a *motif* of the design an Easter lily, wrought either in enamel or silver and gold and set with Oriental or baroque pearls, crosses, bar pins having in the center a pearl studded dove, which is another emblem of Easter, gracefully designed hat pins, etc., etc. These articles should be numbered and another page might be devoted exclusively to prices printed after the numbers and a brief description of the article.

Several attractive folders are shown in the accompanying group, most of which were used by Canadian jewelers. The folder bearing the title, in a cross-shaped design, "Easter Gifts," measures two and one-half inches wide by five and one-half inches high, and was used by Ryrie Bros.,

ing last year was E. A. Koetsch, North Tonawanda, N. Y.

Text for St. Valentine's Day Advertising.

The following rather interesting text may be used with good results as an introduction to matter more commercial in tone, in folders issued to advertise gifts for St. Valentine's Day:

St. Valentine's Day originated in pagan Greece, but history has failed to record the date. During February great feasts were held in honor of Juno and Pan, who were supposed to hold power over the love affairs and the material prosperity of the chosen few.

Youths and maidens sought the sylvan nooks sacred to these deities, and told their secrets and desires to the statues erected everywhere in their honor—hung festoons of flowers about their necks and placed offerings at their feet.

With the coming of the good old saint, Valentinus, the Grecian goddess Juno was left entirely out of the celebrations, and all the honor went to St. Valentine—the anniversary of whose martyrdom is commemorated to the present day.

Centuries have changed these ancient customs, and the festivities now partake of an entirely different nature—the Valentine dinner and party being one of the most popular social functions of the year.

This was used last season in a folder printed in red and gray, by Ryrie Bros., Toronto, Ont.

The Business Man in Advertising.

HAVING made up one's mind to advertise, what is the best way to proceed? asks a writer in *Fiber and Fabric*. There is but one way—apply the same common-sense, business-like principles that are used, say, in the purchase of machinery.

Buy the kind that the conditions determine—and no other. When the conditions change or wear out, change the machinery.

In buying machinery, the purchases are not made to adorn a junk pile, because some good fellow comes along and has it to sell. A definite end is in view, and the machinery is bought for that end.

Let advertising be bought that way, and like well-adapted machinery, it will become more efficient and the results lots more interesting.

The vehicles of expression should be like those of locomotion—adapted to the needs. Cattle are transported in cattle cars, barring exceptions, and passengers take certain other upholstered coaches. One goes by the name of freight, the other by the name of passengers.

So in advertising. Let's not send it out by cattle train when the passenger train takes it quicker, better, and, results considered, cheaper.

Having bought the machinery—the space—what shall be done with it? Was it bought for a souvenir, or as a dividend-producer? Having decided, make it pay.

And here's another tip: Business is not a matter of chicanery any more. The machine man would rather sell something that will make good than something that will not. So, too, with the man who sells space. Each knows his best assets are his satisfied customers.

When you buy the machine on the supposition you bought it to use, is it run "by guess and by gosh" or is the maker allowed to offer a few suggestions?

When you buy space, you'll find all up-to-date papers have someone to aid in the using of the space. Use them.

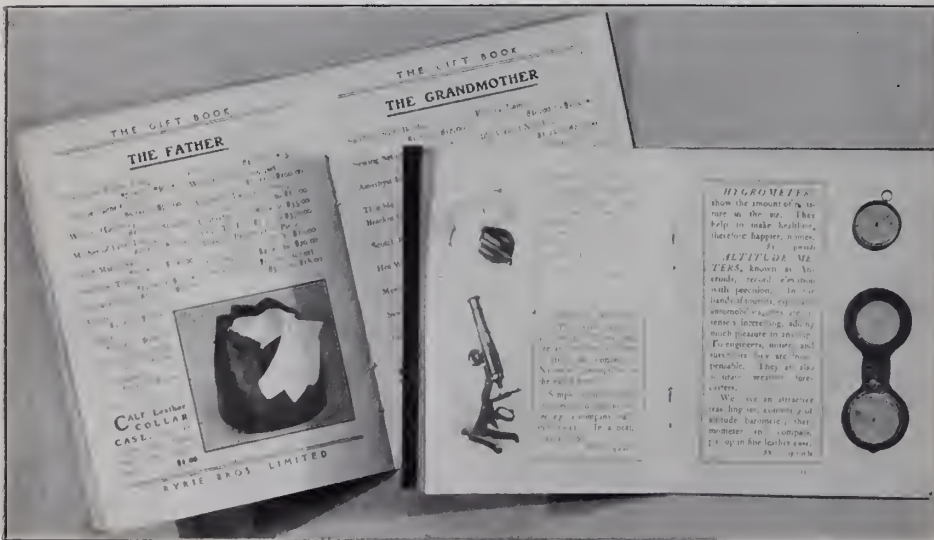

EXAMPLES OF NEATLY MADE-UP BOOKLET PAGES.

[Used by Ryrie Bros., Toronto, Ont., and E. B. Meyrowitz, New York, respectively.]

newspapers, the most valuable advertising medium available for the jeweler. If you want to try the booklet plan, don't miss the chance of issuing one before Easter.

The Make-Up of Folders, Etc.

Jewelers who do not care to go to the expense of supplementing their newspaper advertising during the Easter season with pretentious booklets, will find folders very serviceable. These may be printed for almost any price, depending entirely upon the size, the nature of the composition, quality of paper, etc., etc. The front cover page of an Easter folder should, of course, bear some symbol of the season. Among those which have been used are the rabbit, the Easter lily and, for an ecclesiastical line of jewelry, the cross. The following text is available for a small two-leaf folder measuring about three and one-half by six inches:

Easter Jewelry. There is nothing more appropriate for an Easter gift than a dainty brooch, hair comb, hat-pin or pair of collar pins. This season's styles are plain or ornamental gold or set with amethysts, pearls and sapphires. Gold crosses, heart and other special Easter designs, as well as

Toronto. The pond lilies show up very prettily in the original, which is printed in green and white. There are two leaves in this folder which illustrates a neat line of Easter jewelry.

"Easter Gifts" with the Easter lily on the left is the title of a folder used by Henry Birks & Sons, Montreal. It is three and three-quarter inches wide by nine and one-quarter inches high, and contains three leaves, or six pages. One page is devoted to a list of prices, while three pages are taken up by beautiful half-tone plates illustrating Easter jewelry of original design.

A very attractive little booklet of 12 pages is that entitled "Easter Greeting." A cream-colored calendar paper is used. The printed matter is done in black embellished with half-tone illustrations in yellow, of a chickling, shown in various stages of development. The inside pages also have a yellow border. The booklet calls attention to gifts for Easter, graduation, engagements and weddings. Among the jewelers who used this style of advertis-

A. FRANKFIELD & COMPANY
 THIRTY-EIGHT WEST
 BROADWAY NEW YORK

NEW YORK

The Gift Book

THIS is the best Christmas gift and to most presents. It is a complete directory of the holiday. The stamp comes with it and is a most useful and practical gift.

ANNUAL CATALOG

M. GOLDSMITH & SON
 JEWELERS
 1206 F. Street, N. W.
 WASHINGTON, D. C.

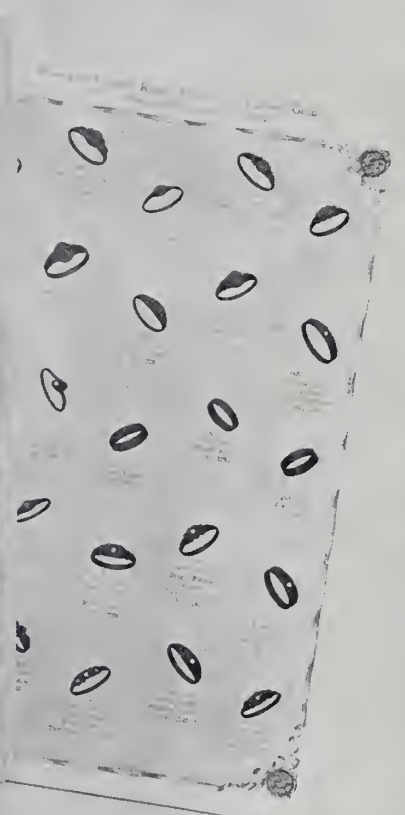

Post Card.

The Jewelers Circular
 New York

Hints for the Christmas Shopper

Don't miss the best of the season which is here before you. Buy your Christmas gifts now. Buy your Christmas gifts now. Buy your Christmas gifts now.

Little Hints for the Xmas Shopper

Hartleben & Co.

The Jewelers Circular

11 John St
 New York

How Some Retail Jewelers Supplemented their Newspaper Advertising During the Holiday Season

(See group of booklets, etc., illustrated on page 233.)

“THE Gift Book,” illustrated in the upper right-hand corner in the group, was issued during the holiday season by D. Buchanan & Son, Richmond, Va. This booklet measures three and one-quarter inches by six and one-quarter inches, and contains 20 pages, excluding the cover pages. The cover pages are of a fine grade of white corrugated paper. In the center inclosed by a gold oval-shaped border is a *bas relief* embossed design, showing the bust of a beautiful woman. This is a remarkable example of skillful die work, even the lace garment worn about the shoulders being cleverly represented in all its fine details. A gold oval border surrounds this head. Two of the inside pages are illustrated on either side of the booklet. The booklet is written in a pleasing style and suggests a number of suitable gifts for every member of the family. There are several memorandum pages in which notes may be made of the intended gifts.

A. Frankfield & Co., retail jewelers, of 38 W. 34th St., New York, distributed this season as a holiday announcement a very dainty pamphlet of eight pages. The cover pages are of a manila shade. The printing on the front cover page is done in gold, embossed on a panel of green, which makes a most beautiful effect. On the back cover page is simply an embossed monogram of the concern, also done in gold. The inside pages are of an extra fine quality of heavy gloss paper, the printing being done on a very light green background. There are several half-tone illustrations of attractive holiday novelties and artistic jewelry, each article being numbered and prices quoted in the lower right-hand corner. A great deal of art work has been done on the half-tones, which show up very strikingly. The last inside page shows a vignette half-tone illustration of the building occupied by the concern.

The annual catalogue of M. Goldsmith & Son, Washington, D. C., contains 62 pages, six and seven-eighths inches by nine and seven-eighths inches. These pages are profusely illustrated with line and half-tone cuts, portraying a varied assortment of cut glass, jewelry, silverware, case goods, watches, etc., etc. Some of the illustrations, especially those of rings, brooches, La Valieres, lockets and euff buttons are done in colors, depicting the actual appearance of the various precious stones, etc. The front cover page shows the bust of an Oriental type of woman bedecked with jewelry. The main part of the cover, which represents a frame for this head, is printed in colors to imitate a Russian bronze effect. The conventionalized floral designs have the appearance of standing out in relief. Two of the inside pages are shown on either side of the front cover.

In the extreme lower left hand corner is reproduced a post card of the folder variety. The card consists really of three distinct post cards, showing various views of

the establishment of the Arnold Jewelry & Music Co., in Ottumwa, Ia.

Adjoining this, on the right, is shown a little holiday book by Chas. Hartdegen & Co., Newark, N. J. It measures three and one-quarter inches wide by four and one-quarter inches high. The cover pages are printed in white and olive green, and the title on the front cover, which is shown herewith, is printed in maroon and embossed, as also is the firm name. The inside pages have a border consisting of a very light green floral design.

A genuine novelty in the way of post cards has been used by E. P. Roberts & Sons, Pittsburg, Pa. When this novelty is spread out there are seen printed in their natural colors several beautiful jewelry designs. There are also illustrated, by means of attractive half-tones printed in three colors, different views of the Roberts establishment. This unique folder is kept closed by means of the one-cent postage stamp.

One of the most comprehensive catalogues seen in a long time is that issued by the Allan Jewelry Co., Charleston, S. C., under the name of “The Grey Book.” The catalogue measures 11 $\frac{1}{4}$ inches by 8 $\frac{1}{2}$ inches. The cover pages are bound in gray cloth, the printing, including the title and monogram in the center, being done in brown. An interesting feature of this catalogue is the reproduction from a rare old print of a portrait of George Heriot, who was jeweler to King James VI. The firm inserted this picture in the catalogue, believing that it would be of general interest to the jewelry trade. It is of peculiar interest to James Allan, Jr., of the firm, because his wife is a descendant of the brother of the court jeweler. There are, moreover, a number of the members of the Heriot family and their descendants living at the present time in Charleston.

The first few pages are devoted to a description of points of interest in the home city, and this is followed by beautiful half-tone illustrations of various departments of the establishment, including the diamond, jewelry, watch, die cutting, chasing and manufacturing departments. The line illustrated is a most elaborate one, comprising a variegated lot of original designs in jewelry, silverware, cut glass, clocks, chandeliers, bronzes, etc., etc. Inserted in the end of the catalogue are several order pages which are indented and may easily be removed.

An exceedingly attractive booklet, also bearing the title “The Gift Book,” was issued during the holiday season by Ryrice Bros., of Toronto, Ont. The booklet measures three and seven-eighths inches by five and one-quarter inches. The cover pages are of a dark brown hue, the front cover page being printed in blue and red. There are 12 inside pages, all of which are illustrated with clean cut half-tones printed in brown and representing a line especially adapted to the holiday season. Each page

offers suggestions for the giving of gifts to “The Baby,” “The Boy,” “The Girl,” “The Young Lady,” “Young Man,” “Mother,” “Father,” “Grandmother,” “Grandfather,” and “Our Friends.” The list under each of these gifts is rather comprehensive, and prices are quoted in every instance.

“Gifts of Value” is the title of another well-printed booklet, issued during the holiday season by E. B. Meyrowitz, New York. The cover pages are red. The front page is decorated with a design in gold, which represents a conventionalized Christmas tree. This design forms a frame for a quotation from Byron printed in black: “All who joy would win must share it—happiness was born a twin.” The printing of the inside pages is done in green and the text is enclosed in a neat red border, leaving a margin of nearly one and one-half inches on the side for the insertion of dainty half-tones illustrating the articles described. The vignetting of these cuts is unusually good. The booklet is of convenient size, measuring only three and one-half inches by four and three-eighths inches.

A pamphlet of eight pages, entitled “Gifts for all Occasions,” was used by J. D. Bailey, Toronto. The paper stock is light grey in color, the printing being black and red, the latter color having been used for the captions. A well-selected stock is illustrated and described.

“The Spirit of Christmas Giving” is the title of a very attractive booklet, issued by W. F. Fisher & Bro., Chattanooga, Tenn. The cover pages are white, and the title is printed in green with the initial letters red, embellished by an ornate conventionalized design of Christmas holly, which is also printed in two shades of green and one shade of red. A comprehensive line of jewelry and art goods is tersely described and there are also offered numerous suggestions. Two pages in the back of the booklet are ruled off to serve as a memorandum for the purchaser. There is a blank space for the name of the friend, the nature of the gift and its cost. This booklet is three and one-half inches wide and four and one-half inches high.

Another booklet used by the same concern is devoted to the exploitation of wedding gifts and contains 16 pages. The booklet opens with a foreword, which reads as follows:

Jewelry has ever been the most popular expression of love and regard. The shop of the jeweler and silversmith is always associated with weddings. In fact, it plays a most important part in the major of love affairs. If the suggestions on the following pages are of any assistance in arranging for wedding and help to make gifts more pleasant, little book will have served its purpose.

Then comes a carefully written paragraph on the history of the engagement ring, followed by an unobtrusive announcement of the concern's products. Several pages are devoted to a list of wedding gifts, a range in prices being printed conspicuous above each line advertised. The last pages of the usual information contained in such booklets, including the relative value of precious stones, birth month gems, wedding anniversaries, etc.

The Swope-Nich Jewelry Co., Toronto, Hants, Ind., distributed very attractive printed holiday greetings in the form of a four-page folder.

R. F. J.



WORKSHOP NOTES AND QUERIES

[Answers are also solicited from our readers to the questions published on this page.]

QUESTION No. 2063.—“Trisalyt.”—*Can you inform me what Trisalyt is, and what it is used for? I have noticed mention of it in many German technical publications.*

T. C.

ANSWER:—Trisalyt stands for triple salts, which is a patented triple salt intended for a plating solution. Those triple salts are made in four standard varieties—gold, silver, copper and zinc. The solutions are prepared, presumably, as usual, the salts being used in place of the reduced metals as formerly. Thus for a gold solution the usual liquids are used, adding the salts in place of the chloride of gold. It is claimed that by changing the temperature and current different shades may be produced. Anodes of gold or silver are used as formerly but with a bronze bath both copper and zinc salts are used with a copper and zinc anode.

QUESTION No. 2064.—Tinning Inside of Copper Vessels.—*How can I tin the inside of copper coffee and tea kettles, or any other small articles produced from copper and which require tinning on the inner surfaces?*

T. I.

ANSWER:—To tin the inner surfaces of copper vessels, first thoroughly clean the copper and prepare a mixture of powdered tin, five pounds; powdered salammoniac, 2½ pounds, and about one pint of water, and make into a paste. This is spread over the inner surface in a thin layer and the copper heated until the tin melts. The heating is done most quickly over a gas stove, holding in one position until the tinning is complete at that part; then turn slowly until the whole is tinned over. If there be any seams to solder, this work can be done at the same time by simply putting a little more of the paste at the places to be joined. Soda fountain copper parts are tinned over the inside by heating the body and placing inside small pieces of tin and salammoniac. When melted a tow swab is dipped in chloride of zinc and the tin is brushed around the inside of the body with it.

QUESTION No. 2065.—Platinum Oxide for Brushing.—*How can I prepare platinum for oxidizing silver articles?* P. O.

ANSWER:—Platinum is reduced in an evaporating dish by taking scraps of platinum wire and pouring on two parts of muriatic acid to one part of nitric acid, both C. P. Then gradually heat the dish over hot sand, or by some other method, until the platinum is reduced. Keep the dish warm to evaporate the acid until it is of the thickness of syrup, when it must be allowed to cool. Then add one-third of its volume

of alcohol and bottle for use. The articles to be oxidized should be perfectly clean and slightly warm. Paint on the platinum oxidize with a camel's hair brush. If the piece does not turn black at once, then heat again. When the proper black is obtained rinse in water and then rub on pumice and water. The oxidize will withstand the action of the air better than other methods, but a lacquer will give the piece a better appearance. The fumes from the cutting down are dangerous and must not be inhaled.

QUESTION No. 2066.—Gun Metal Finish.—*Please give me a formula for a simple method of producing the gun barrel finish on metal novelties.* G. B.

ANSWER:—One way of producing a gun metal finish is to begin the operation as for any other finish by polishing and thoroughly cleaning. Prepare a mixture of equal parts of chloride of antimony and cottonseed oil, adding a little nitric acid. This preparation should be of the consistency of thick cream, and is painted on the metal articles, which should first be slightly heated, covering the pieces completely. Let remain for 24 or 30 hours, when the excess can be removed. This is one of the simplest and cheapest methods known for producing this finish.

QUESTION No. 2067.—Black Diamonds for Drills.—*What are the black diamonds found in Brazil used for?* B. D.

ANSWER:—The black diamond is about 25 per cent. more valuable than the white, and is used mostly for drill points for core drilling in mining. It is the hardest substance known and stands tremendous pressure.

QUESTION No. 2068.—Watch Oil Preparation.—*How are watch oils prepared and what are the ingredients?* W. O.

ANSWER:—An interesting article on watch oils by Prof. E. James, Geneva, Switzerland, appeared in the issue of THE CIRCULAR—WEEKLY of Jan. 8, 1908. The following method of preparing these oils was recently published in the *Scientific American*: A mixture is prepared of cocoanut oil, spermaceti, olive oil, neat's-foot oil, and a very small quantity of mineral oil. The cocoanut oil and the spermaceti will remain liquid even at very high temperatures. The mixture is exposed to sunlight in an open bottle until all the colored and foreign substances are collected at the bottom, and then filtered through a mixture of bone and wood charcoal. It is claimed that this oil retains no glutinous property and will not oxidize the metal, and that it will not deteriorate at all. There are great numbers of brands of

horological oils. Each producer, of course, considers his the best. Unfortunately, competition compels him to lower the price, which often results in the deterioration of the quality. Now, every oil designed for such delicate mechanism as that of watches should be free from acid or mucilage. In a word, it ought to be pure olcine. The method of scouring oleine is not difficult. It consists in putting the oil into a receiver, with eight times its weight of concentrated alcohol, boiling for 10 minutes, decanting the liquid, allowing to cool, evaporating until its volume is reduced to one-fifth, filtering, and keeping in a well-stopped bottle.

QUESTION No. 2069.—Stripping Gold from Jewelry.—*We want to know how to strip gold from jewelry, especially to strip off the coating caused by soldering. We understand there is some way of treating this with a Bunsen cell battery.*

S. G. & Co.

ANSWER:—The stripping of gold, be it from another base of metal, or from gold articles containing a coating or discoloring from soldering operations, may be stripped with a regular zinc battery, such as is used for producing the current for deposition, and with a solution made as follows: In an enameled iron kettle put one quart of water and two ounces of cyanide of potassium; then bring the solution to a boiling point. Lay a copper rod across the kettle and connect with the positive pole of the battery. A bright piece of sheet iron is bent double and hung over the copper rod so that the two ends of the sheet iron will be well immersed in the solution. Another strong copper wire is connected with the negative wire of the battery, with a hook shaped on the end of it. The articles to be stripped are placed on the copper hook, say three or four rings, the current is turned on, and the articles are placed in the hot solution, moving about near the sheet iron, but not touching it. In a few moments—sometimes less than half a minute—the gold pieces will begin to appear bright and clean, which indicates that they must be removed. The current required is about four volts, which will strip off the coating very rapidly. Too much stripping is not good, as it has a tendency to roughen the pieces, but if in good working condition the pieces will come out as if polished. The polishing necessary will, by this means, be materially reduced. Long pieces, such as chains, may be connected with the hook at one end, the other end held in one hand and the same drawn slowly through the solution, which will clean them. The solution will soon evaporate and must be replenished with water. The cyanide, too, must be replenished after much using. The solution will soon be charged with considerable gold. The old solution must be saved until a sufficient amount has accumulated, when the gold may be recovered.

QUESTION No. 2070.—Oxidizing and Bronzing.—*Please tell me how I can oxidize brass articles to a black or dark blue. Also how to bronze or some way to keep steel from getting rusty while in stock. It will be impossible to handle pieces separately, as they are small articles, such as screws and split rings. The rings are steel and*



HERPERS BROS.,
MAKERS OF
"SWASTIKA" SETTINGS
IN 10, 14 AND 18 KARAT GOLD AND IN PLATINUM
ALSO A COMPLETE LINE OF GALLERIES AND FINDINGS

Plain and for Enamelling IN THREE SIZES

OFFICE AND FACTORY NEWARK, N. J., U. S. A. NEW YORK BRANCH 41-43 MAIDEN LANE

WORKSHOP NOTES
(Third Edition)
For Jewelers and Watchmakers
PRICE, \$2.50

Published by
THE JEWELERS' CIRCULAR PUBLISHING CO.
11 John Street, corner Broadway, New York



A Small Compound Sand Blast

Price, \$20.00 Foot Bellows, \$6.00

WORKS AS EFFECTIVELY WITH FOOT BELLOWS AS WITH POWER BLOWER : : : :

MADE of Galvanized Sheet Iron, 10 inches diameter, Glass Top, Fittings of Brass and Iron, practically indestructible. Satisfaction guaranteed. Ask your Jobber for it, or write to us. Other Specialties: Zeuner's Best Jewelers' Saws; American Swiss Files, equal to the best imported; Gas Furnaces, for Melting, Annealing, etc., etc.; Positive Pressure Blowers.

E. P. REICHHHELM & CO.
JEWELERS TOOLS, FILES AND SUPPLIES
24 JOHN STREET, NEW YORK



LANDIS SCHOOL OF ENGRAVING
SPRING COURSE—Opens April 1st, 1908

If you wish to take a course this Spring, please WRITE US AT ONCE, and we will assign and hold a place for you.

Our new school rooms have every modern convenience and comfort. Our methods are original and entirely new. We are the founders of a new system in the art of Cutting and Designing, which enables a pupil, not endowed with artistic skill, to learn to make perfect letters. Write us, and we will give you an idea of what you could accomplish by taking a course with us.

M. L. LANDIS, 119 Mt. Vernon Ave., Detroit, Mich.
Positively no Mail Course Given. Attendance Only.

M. L. LANDIS
Proprietor and Instructor



Jewelers **Solderene** Paste No. 501 25c
Manufactured expressly for Jewelers, Opticians, Dentists
Solderene Company, Boston, Mass., U.S.A.

A PURE SOLDER IN PUTTY FORM

Apply to place to be soldered using iron or flame. Requires no acids, rosin, pastes or other fluxes. Absolutely neutral, preventing rust and corrosion. Saves time and waste. Large sizes for the manufacturing trade. If your jobber does not carry it in stock send us his name and 25 cents and we will send you No. 501 jar, prepaid.

SOLDERENE COMPANY (Dept. 0)
91 Oliver Street, Boston, Mass., U. S. A.

Importer and Manufacturer of WATCH MATERIALS, TOOLS, JEWELERS SUPPLIES AND OPTICAL GOODS

Bargains in Engraving Blocks

Prices on Application



Fine Gold, Silver and Platinum always on hand. Highest Prices paid for Old Gold and Silver.

A. ZAREMBOWITZ
250 East Houston Street NEW YORK

PLATINUM AMERICAN PLATINUM WORKS
NEW YORK OFFICE 41 Cortlandt Street
NEWARK, N. J.

Workshop Notes Department.

swivels brass.

J. H. & Co.

ANSWER:—(1) Small brass articles are best handled in a steel wire or glazed stone coping receptacle. The articles should be chemically clean and made out of sheets or tubing, then a good dip in benzine will free; but if articles are cast, a regular dip should be employed. The black coat is obtained by dissolving potassium cyanide in warm water strong enough to give the desired dark shade. The articles are placed in the perforated basket and passed through the cleaning process, then dipped in the oxidizing solution and shaken gently to insure a perfect coating. The basket should be placed in a warm place for a few minutes so it will be nearly dry, then the articles should be immersed in aqua regia and placed on a wire netting to dry. It is best to use a wire basket for the cleaning, as this will save one the trouble of cleaning the basket after each operation. Any brass articles are coated with black lacquer, this dispensing with the oxidizing solution. Otherwise the process is the same. (2) A good recipe for oxidizing brass is powdered sal ammoniac. Moisten with distilled or rain water, and apply the mixture to the metal and then rub dry with an orange or whiting; or wash the brass with black alum boiled in strong lye in the proportion of one ounce to one pint. When dry, rub or brush with tripoli. Either of these receipts will give brass the brilliancy of gold.

PROCESS OF REMOVING RUST FROM STEEL AND IRON.

(1) Henry C. Abbott's recipe is simply to immerse the article in a solution of carbonate of potash for a few minutes, and it will not rust for years, even when exposed to damp atmosphere.

(2) In a vessel placed on the fire put a layer of three to four centimeters of coal dust on the bottom; three to four centimeters higher place a grate on which the articles to be treated are laid. Close the vessel and heat for about half an hour, maintaining the bottom of the vessel at a dark red. At the end of the time retire from the fire and take out the articles which have acquired a handsome layer of black enamel. This brilliant coating is very durable and permits of exposing the pieces to all the variations of temperature. A good result is also obtained by covering the objects with a hot solution of sulphur in essence of turpentine.

(3) Tools require a great deal of attention to keep them in good condition. The periods of idleness are especially fatal to them, for when the atmosphere is humid traces of rust promptly appear on their surface, which attack the metal. The following is the method for preserving the metal from rust: Dissolve in 450 to 500 grammes of melted lard 15 grammes of sulphur. The hot liquid is skimmed; next add one-half kilo of graphite, in order to give the substance the desired metallic color. Grease the tools with this after cooling, and leave the coating on for 24 hours. Now wipe off entirely with a soft cloth. There will remain a slight coating sufficient to keep the air, and consequently

the rust, away from the metal, while imparting to it a bright appearance.

The Preparation of Chemically Pure Gold.

COMMERCIAL gold is never pure, although it answers for the majority of purposes such as coinage, jewelry or leaf, says the *Brass World*. For fine gold plating, however, a chemically pure gold is frequently necessary, and it may be of interest to know how it can be made.

Commercial gold bars usually run from 997 to 999 in fineness. They are more frequently found 997 than of a higher percentage. The reason for this apparently impure metal is that in the ordinary parting process, as practiced by the United States Assay Office, where practically all the gold used in our own country is refined, it is impossible, without a greater cost, to eliminate the last traces of impurities. As gold of the aforesaid fineness is suitable for the majority of purposes (particularly coinage) it is allowed to pass without any additional refining.

The impurities in commercial gold are silver, copper, tellurium, antimony, platinum, lead, bismuth, arsenic, iron, selenium and occasionally traces of quite rare elements. Silver and copper, however, are the principal impurities, as they resist the nitring process when a metal like lead would be thoroughly oxidized out. For this reason, gold refining can be carried up to a certain point by the use of niter, but it then must stop, as the silver and copper resist the action of this substance.

For completely purifying gold, the method employed by the British Government in the production of its pure gold Trial Plate, preserved by the Warden of Standards, is excellent. It can only be equalled (probably not surpassed) by the Wohlwill process of refining gold electrolytically. The Wohlwill process, however, is patented and a royalty must be paid in order to use it, and, too, special equipment is needed for working it. Those who wish to make small lots of chemically pure gold will find the following method capable of producing metal of the highest degree of purity. The process is as follows:

The purest gold obtainable is either granulated or rolled into sheet. It is then dissolved in aqua-regia (nitric and muriatic acids). For every ounce of gold use three ounces of strong, chemically pure muriatic acid, and one ounce of chemically pure nitric acid. If the gold is in large pieces, more acid may be needed at the end of the dissolving process; and if this is the case, then more can be added. The dissolving is preferably carried out in a glass flask, heated by a sand bath. The long neck of the flask prevents the loss of gold by sparging. When everything has gone into solution there will usually be a small quantity of flocculent residue left. This is chloride of silver that will not dissolve.

Now pour the solution into a porcelain evaporating dish and rinse out the flask with distilled water. Evaporate it until it becomes dark red and syrupy. A sand bath should be used for this purpose, and care must be taken not to evaporate too far; otherwise the chloride of gold will become

"burnt" (i. e., it will change back to metallic gold). The dark red liquid thus obtained is chloride of gold and is allowed to cool.

The chloride of gold is then dissolved in pure grain alcohol (denatured alcohol will not answer). Add just enough alcohol to dissolve it (leaving the slight residue of chloride of silver which the alcohol will not dissolve) and then add 1 pennyweight of chloride of potassium to every ounce of gold. This is to precipitate the platinum. The platinum separates in the form of a yellow crystalline precipitate. It is soluble in water but not in alcohol, and it is for this reason that the alcohol is used.

The solution is allowed to stand overnight and filtered to remove the platinum precipitate (potassium platonic chloride) and then water is added so that each gallon of solution contains half an ounce of gold. In this condition it is allowed to remain for three weeks, in order to allow all chloride of silver to separate out. After this period has elapsed the solution is filtered through fine filter paper or the clear liquid siphoned off.

To the clear solution thus obtained and heated to about 120 degrees Fahrenheit, a strong solution of oxalic acid in water is added. The solution is maintained in a warm condition for some time and all of the gold will be precipitated as a spongy mass of brown color. After the solution has remained for a few hours all of the gold will be precipitated. It is allowed to settle and the clear liquid above it is siphoned off. Distilled water is now added and the whole stirred and the gold again allowed to settle. The clear liquid is siphoned off as before and the operation repeated five or six times. Dilute muriatic acid (1 part of acid and 10 parts of water) is now used instead of the water and the precipitate washed several times. The washing with water is then repeated once or twice to remove the acid left and ammonia water then is used for washing the gold. The washing is carried out several times and the gold is finally transferred to a fine, washed filter paper and washed repeatedly with water. In this manner all of the impurities are washed out.

The gold is now dried and removed from the filter paper to an unglazed porcelain crucible. In this it is melted under a small quantity of bi-sulphate of potash and borax (equal parts) for a flux. When melted it is poured out upon a slab of stone or in a stone mold in order to avoid contamination with iron.

The Trial Plate which the British Government made in this manner weighed 70 ozs., and the average purity was 999.96. While the process is too expensive for many commercial uses, it illustrates the care that must be used in the production of a pure metal.

L. M. Solans, Rockwood, Tenn., has resumed business at that place. The store was closed for a short time.

David Cederman, until recently with Fred. Johnston, Bradford, Pa., has been admitted as a partner in the business of L. C. Bullard, and the new firm name will be Bullard & Cederman. The store will be located at 21 Congress St.

Import
Line
Now
Ready



Immense
Display
of
Novelties

CASE No. 181
16¼ in. high, 12¼ in. wide, 8¼ in. deep.
Finest Cabinet Finish, Solid Mahogany, American
Made, Westminster Chime, Tubular Fitting.

B. & D. Chiming Mantel Clocks for 1908 have a New Movement and American Mahogany Cases

OUR experience in the German Chiming Mantel Clock business has proved two things—that foreign made wood cases will not survive our climate, and that the ordinary cheap movements that usually go with them are not dependable timers or chimers. ¶ Therefore we are now building all of our Mantel Clock Cases here in America (as we have Hall Clock Cases for years), in classic models, of solid mahogany, and finest cabinet finish—as the best craftsmen only can produce—cases that will outlast generations.

¶ Every dealer who has handled cheap German Westminster Chiming Mantel Clocks has experienced trouble with the striking mechanism. They could not be made to strike and chime correctly. Only an expert could manipulate the hands, or the clock would get out of order. Many dealers refused to handle them at all.

¶ Our New Movement is built after the best English construction, superbly finished, fitted and adjusted in the case in our New York shops, and every clock goes out with a guarantee to run true and strike and chime correctly in any position. ¶ It is a clock the most exclusive dealer can sell and stand back of. Where he now must ask \$75.00 for a clock he can guarantee, ours can be sold profitably for even less than \$50.00, with fine rich dial with raised figures. Controlled by B. and D.

CHEAPER MANTEL CLOCKS

¶ To supply a certain demand for very cheap clocks we carry also the regular Junghans' movement, with so-called tubular chimes, with ordinary dial. ¶ Also a special Junghans' movement of heavier construction, with solid steel pinions and rich dial, which, when fitted in a fine domestic mahogany case, makes a good appearance, and is superior to the regular Junghans' article.

BAWO & DOTTER

26 to 34 BARCLAY ST.

Manufacturers and Importers

NEW YORK CITY

"ELITE" TUBULAR CHIMING HALL CLOCKS, GRAND PRIZE, ST. LOUIS.

THE CONNOISSEUR

Devoted to Art Pottery, China, Marbles, Bronzes, Cut and Decorated Glass Ware, Bric-à-Brac, Lamps, Art Metal Wares, Fancy Goods and Kindred Lines.



A Noted British Artist's Work in Glass Portraiture.

PORTRAITURE in glass is as unusual and rare as it is difficult and artistic, and, therefore, the likeness of the late Lord Kelvin, illustrated on this page, the work of George Woodall, England's noted artist and glass sculptor, can be studied with interest by both connoisseurs and dealers interested in artistic work in glass of this character. This portrait, which is considered one of the finest which Mr. Woodall has produced, was modeled from life, and the artist was personally congratulated by Lord Kelvin upon the result of his work both from a standpoint of portraiture and as a work of art. It is now prominently hanging in the Royal Society, Burlington House, Princeton, having been presented thereto by the Society of American Scientists who purchased the work from the artist.

In speaking of this portrait, John A. Service says in an article which appeared in a recent issue of the *American Pottery Gazette*, that this successful and entirely satisfactory completion opens out a wide field for the exercise of such genius and skill in a direction calculated to be of the greatest possible interest in permanently preserving in beautiful and durable materials capable of truthfully rendering the most subtle effects of light and shade in the delineation of human features. In the course of his article upon Mr. Woodall and his work, Mr. Service remarks that no branch of the British glass trade so completely surrounds the name of one individual to the same remarkable degree that sculptured glass envelops the

person of Mr. Woodall, and that though there have been many artists of skill and ability in the glass industry, no single individual equals George Woodall in the extent, variety, originality and exclusiveness of his artistic productions, the author calling particular attention to the fact that the examples bearing Mr. Woodall's signature

Mr. Service goes into a discussion of his figure work and the source of its inspiration, it being in his figure work that Mr. Woodall found his element and scope for his ability, and without totally separating himself from the ornamental portions of his craft, which of necessity would have to be utilized in the accessories of his chosen subjects, he centered his efforts in the study of the human form, the most difficult of all subjects to interpret correctly, and especially so in the form of low relief contingent upon the medium

employed to produce his effects.

His success on his chosen field is a matter of common knowledge, and his beautiful figure plaques whether they be his full single figures of "Hebe," "Pandora," "Aphrodite," etc., his beautiful symbolic representation as "Night" and "Morning," or his later magnificent groups, as the "Toilet of Venus," "Roman Bath," etc., up to his last piece of importance, "The Dance," are all familiar to those who deal in exquisite luxuries. His portrait work, however, especially the plaque illustrated herewith, show him to be possessed of an ability in addition to imagination and artistic instinct, with which few, if any, other workers in this line were ever blessed.

"Near" Porcelain.

STAFFORDSHIRE ware in its best period (salt glazed stone ware) is easily mistaken by amateurs for porcelain. The latter is usually characterized as being "hard, white and translucent." But Staffordshire ware of that early period is often found, when thin, to be translucent as well as being beautifully white.

George A. Knight, Coggon, Ia., recently committed suicide.

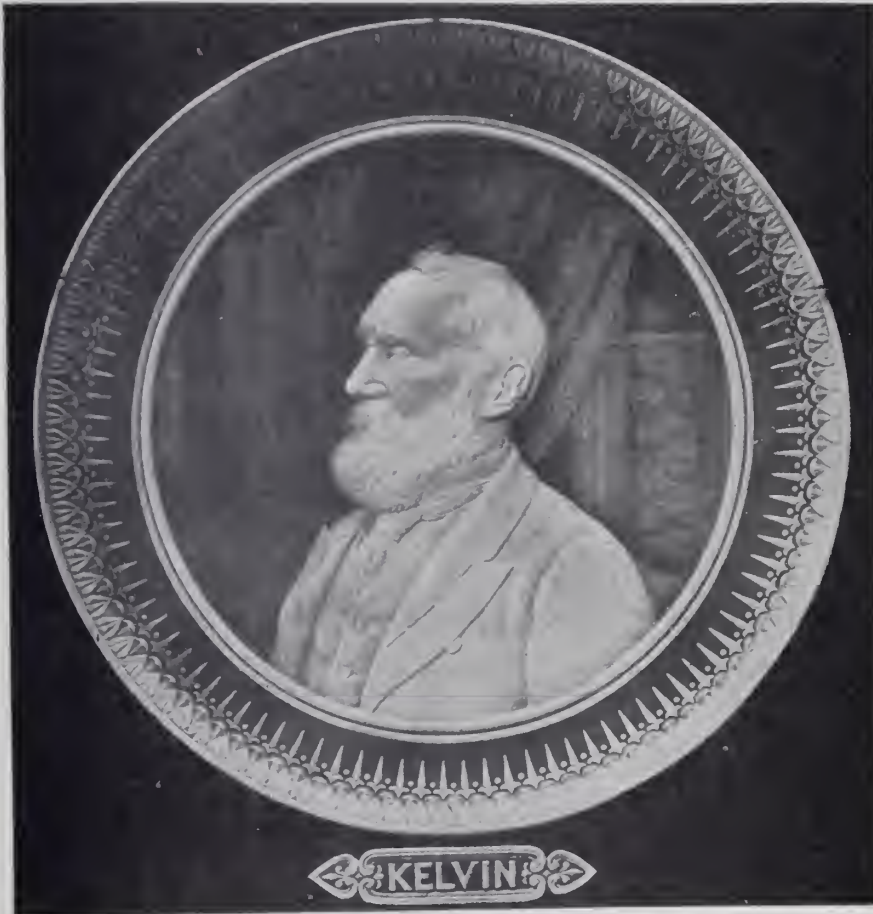

GLASS PLAQUE, BY NOTED BRITISH ARTIST, SHOWING PORTRAIT OF THE LATE LORD KELVIN.

far outnumber those of any other single artist in any branch of the glass industry if specimens that may be classed as representative pieces are taken only into consideration.

After tracing Mr. Woodall's life from his early efforts as an intaglio engraver through his work at Northwood's to his connection with Thomas Webb & Sons,

C. DORFLINGER & SONS

36 MURRAY STREET

NEW YORK



Hand-Made Blanks only.
Cut, engraved and etched
glass. Light, medium
and heavy stemware,
tumblers, etc.



No. 164,
FLORENCE.

Owanda Cut Glass Co.

Manufacturers of

Rich Cut Glass

Originators of New Designs

HONESDALE, PENNSYLVANIA

A complete line of our high-grade goods shown at our
New York Office, 68 West Broadway.

The St. James

Cor. Walnut and 13th Sts., Phila., Pa.

THE IDEAL HOTEL OF
THE QUAKER CITY

A spacious fire and burglar proof
safe has been provided for the con-
venience of the trade. Palatial
rooms with bath \$2.50 per day
and up. Rooms without bath,
(running water) \$2.00 and up.

EUGENE G. MILLER, Mgr.



* Wild Rose,* No. 122—14-inch
Ice Cream Tray

Irving Cut Glass Co. Inc.

Manufacturers of

Artistic Cut Glass

HONESDALE, PA.

F. W. REICHENBACHER

New York Representative 59 PARK PLACE

CROUCH & FITZGERALD



Jewelry
Trunks
and Cases

177 Broadway,
Bet. Cortlandt
and Dey Sts.
688 Broadway
723 6th Ave.,
New York.

BUY CUTTLE FISH BONE

The mark P-E-A-CO. insures quality. Secure our
prices before buying elsewhere; it will pay you.

P. E. ANDERSON & COMPANY

IMPORTERS 7 @ 13 GOLD ST., NEW YORK CITY

JACOT MUSIC BOX CO., IMPORTERS.

Stella and Ideal Music Boxes
39 UNION SQUARE, N. Y.

NOVELTIES

FANS

For the Jewelry Trade

A complete stock of un-
usual and exclusive
designs

Louis Steiner

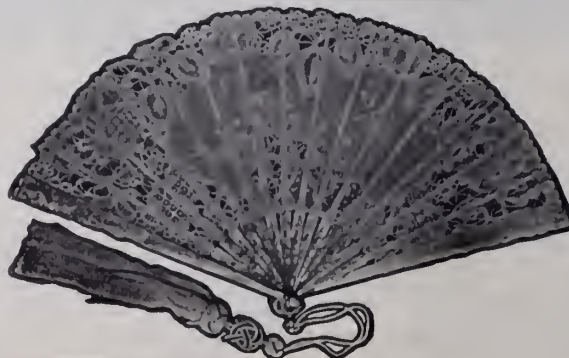

NOVELTIES

FANS

of Every Description

An assortment of Fans
that is unequalled in
this country

520 and 522 BROADWAY
NEW YORK

Toby Jugs and Their Popularity in the Past.

By C. W. Coumbe.

RECENT dispatch from London stated that the collection of "Tobies" is the latest fad. Tobies, this article explains, are the quaint, rotund ale jugs which were popular at the end of the 18th century, and were fashioned into grotesque caricatures of celebrities and popular characters of the period. They are on sale at most curiosity shops in London, but the demand has grown so much recently that prices have gone up amazingly.

"A genuine 'Toby' in good condition and artistically wrought is cheap at \$150," says the writer. "Several thousand dollars' worth of 'Tobies' are being exhibited at the fashionable shop in the West End."

To Americans of the later generation the word "Toby" is a meaningless term in the above connection. So that, should the fad of owning these quaint vessels become prevalent on this side of the "Ocean," as it is in Europe, a short introduction to hisilly presence should prove a commendable and timely act just now.

The above-mentioned dispatch tells us that Toby is a "quaint, rotund jug," "fashioned into grotesque caricatures of celebrities," etc. But it takes more and clearer definition than that to give one a fair

but adapting the caricatured lineaments of other celebrities to the same purpose of ceramic embellishment.

Tobies originated somewhere about the year 1740. And for quite a while they retained that notorious toper's features or a strikingly similar likeness. Hence, the ma-

bibulous enjoyment. Pitchers for water, ewers for wine—but the malted brew inherently is poured from a jug. And a Toby is the real habitat of the foaming draught—at least so for generations, our forefathers thought. The specific purpose for which a Toby is built is so clearly, if not loudly, imprinted in its corpulent form that even empty it brings up memories of malt and hops. Toby would be sacrilegiously out of place on the sideboard—much less the dining table—of a member of the W. C. T. U. unless placarded with a sermon and acting as a *horrid example*.

Toby was, in his heyday of popularity, a typical exemplification of the "good times" of our ancestors. Accompanied by his jug and a "church warden" (the three-foot-long clay pipe displayed in the picture), he represented bucolic ease and happiness. True, the "foaming brew" and the ruddy vintage of those days were innocent of the sophistication of our high civilization. Claret was ignorant of logwood, ale of quassia or glucose.

But, to return more closely to Toby himself, a few more words as to his history and antecedents are due here. Tradition tells us that the jug was named after the noted imbibor, Toby Philpot. But a strange and suspicious circumstance lingers around this story. And some of us must beg forgiveness if we fail to accept in all earnestness this small scrap of history unless fur-



FIG. 1.—TOBY PHILPOT.

majority of those still existing, more or less closely resemble the jug-nursing figure posing in the rough sketch over his name on this page.

It is in doubt as to what potter first produced these odd jugs. Ralph Wood modeled many Staffordshire earthen ware figures, and some claim that he originated the Toby. Ralph Wood was a contemporary of Josiah Wedgwood. He started a small pottery in Burslem about the year 1740, and there made such figures. He was, by the bye, brother of Aaron Wood, the most famous "block cutter" of salt-glaze moulds. Many of Ralph Wood's figures—especially his best typical "groups"—are the most highly prized pieces of the potter's art in the collections of some connoisseurs.

Shakespeare says: "What's in a name," etc. Now, some contend that the word "jug" is redolent of the "good" things in liquid form. Spiced ale, mulled claret, fit closely and intimately into jugs, or even the "half and half" of the Britisher's later



FIG. 3.—SAID TO BE BENJ. FRANKLIN.

their authentication comes to hand. By some of the authorities of those days this gentleman of bibulous faculties has his name spelled variously both "Philpot" and "Fillpot." Hence our doubts.

However, it must be borne in mind by the judiciously inclined that, in those days, considerable caligraphic freedom existed, and it was a poor, unresourceful scribe who could not spell the same word at least two different ways. And, if Smith cropped up vicariously as Smyth or Smythe, then why not Philpot as "Fillpot"?

Anyhow, it will be the proper part of the retail jeweler, when he soon begins to handle these quaint wares, to accept in implicit faith Toby Philpot's cognomen and



FIG. 2.—CARICATURE OF CHARLES II.

acquaintance with our grandfathers' and great-grandfathers' old genial companion, Toby Philpot." And this is the full title of the ale jug above mentioned.

You naturally ask, "Why call a jug 'Toby Philpot'?" The reply that tripped off the tongues of our grandfathers when that question was asked by the uninitiated was—that Toby Philpot was a well-known toper of that day, and of his acquirements a topical saying ran: "A thirsty old soul as e'er drank a bottle or fathomed a bowl." And the form of this Toby's effigy, the jugs at carried his title were first formed.

Once familiar to the British public in this quaint figure, the natural outgrowth of the fad was to devise ale jugs of similar style,

Cut Glass THAT PLEASURES

*Artistic Patterns
Superior Finish*

Our name stands for

Excellence and Quality

We will be pleased to add
your name to our list of

Satisfied Customers

Kelly & Steinman, Inc.

Manufacturers

HONESDALE, PENNSYLVANIA



No. 211—4 Pint Jug
ASCOT

The "SECURITY" Necklace Clasp

No. 1 Locks here

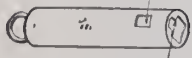

No. 2 Locks here

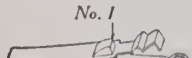

No. 1

No. 2

Patent applied for.

HEAR IT SNAP

Absolutely Secure and
Simple. Cannot Pull Out
LOCKS IN TWO
PLACES

Making it Doubly Secure
The Only Perfect Clasp

Ask Your Jobber or Write.

PRICES TO THE TRADE:

No. 1	10-Karat.	- -	\$6.00 doz.
1-B.	10	- -	7.00 "
1.	14	- -	7.00 "
1-B.	14	- -	9.00 "
2.	10	- -	9.00 "
1.	Platinum.	- -	18.00 "
1.	Gold Filled.	- -	2.00 "
1-B.	"	- -	2.25 "
2	"	- -	2.50 "
1.	Sterling Silver.	- -	2.00 "

The Hoffman Novelty Co., Makers, 79-83 No. Pearl St., ALBANY, N. Y.

"CLINCH"



No. 2
50 cts.
35 cts.



Patent
applied
for.

Safety Catch for Scarf Pins

Does not mar the
pin. Nothing to get
out of order. Simple
and neat.

One turn to the
right grips like a vise.

..FITS ANY SIZE PIN..

PRICES TO THE TRADE

No. 1 Gold Plated	\$1.50 doz.
No. 2 Roman Gold	2.00 doz.
No. 2 14k G'd Pl'te	2.25 doz.

No. 1, 25c.

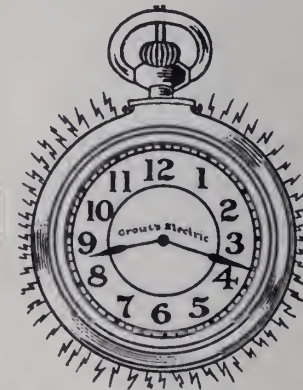

Electric
Flasher
Watch
Sign
\$8.50

Greatest novelty and window attraction ever made. Heavy oval frosted glass body, 10 inch diameter, gold finished crown and bow enameled lettered dial. Will hang on any cord c socket. Sold by all jobbers, or

GROUT'S EXCELSIOR SIGN CO., Chicago, Ill
Send for Catalogue 126 Dearborn S



LEMAIRE OPERA GLASSES

LEMAIRE FIELD GLASSES

Best in the World. Used in the Army and Navy.

SUSSFELD, LORSCH & CO., Importers

37 MAIDEN LANE, NEW YORK

MARQUE DE FABRIQUE



All Genuine Glasses
Bear This Mark
Large Variety in All
the Latest Styles

existence and pass them over the counter, together with the Toby, that the customer may swallow the myth (in blind innocence of "Fillpot" misspellings) together with the cute jug's contents.

For Toby will soon be among us and we should not cast aspersions on his genealogy to injure his entree into American society.

But, perhaps, the best way to get an intimate acquaintance with Toby, his times and his doings is to bury one's nose in Dickens' masterly description of those days depicted in "Barnaby Rudge." Therein we find the honest locksmith, Gabriel Varden, in his famous workshop, the "Golden Key," wiping his brow after a stint of exhausting labor. Then he "lifted Toby to his mouth and took a hearty draught," after which he put the mug down empty on the bench whence it had smiled on him before."

Now, these words open up a new phase of enlightenment, for Gabriel uses the Toby to drink from, and Dickens styles the vessel a *mug*. For, while the Toby was really intended for an ale *jug*, it was used by the working classes and others suffering from inordinate thirsts as a drinking vessel, and a few draughts of those parched throats soon saw the bottom.

One of the dominating characteristics of Toby jugs, or mugs (whichever you choose to call them), was the towering three-corner hat—the prevailing headgear of that time. Can anyone suggest a better "lip" for pouring from than the front projection? Used as a mug, to drink from, could you propose an improvement on one of the side corners? That hat is certainly an ideal neck for a combination mug-jug.

Cut No. 2 is an extant Toby said to represent in effigy King Charles II. of England. It is supposed to have been set before the public soon after he lost his first battle and his throne. In those days, you see, they loved to bait the "under dog" when he was down and harmless, much as we do now in our present advanced state of civilization.

Tobies were, for the most part, clothed in a modest dark buff, or yellow, body and transparent glaze. But some of the more pretentious productions sported their corpulences clad in gay attire. We find them in red coats, green trousers and other nobby extravagances.

Fortunately for collectors of these relics of the ceramic past the vogue for Toby jugs was no rapidly passing whim. Probably 50 or more years saw them ever popular. Their output also was prolific, and they figured in the equipment of nearly every household. Varden with "Toby at his elbow and his pipe in his mouth" was a general representation those days of peaceful happiness at the English fireside.

But while England was the home of manufacture, yet many Tobies must be still existing in this country. For there were effigies of American statesmen figuring in these jugs for United States export and consumption. Fig. 3 is such an "American" jug. It is supposed to have been fashioned in comic presentment of Benjamin Franklin, and represents him in the solemn act of taking a pinch of snuff.

So that while the earnest quest is being made to bring to light those existing in Great Britain, Americans should be able to

make profitable search in this country for Tobies. In unearthing these curious vessels they will be found nearly always more or less similar to the examples roughly portrayed in this article, but some of the figures hold a jug in one hand and a mug in the other.

And the search is worth while, for the American subjects are scarcer than the English, and will fetch better prices when the fad is at its height.

For, be sure, if the Toby rage reaches our shores his vogue will last as long as in the past, and it is too good and substantial of quality not to deserve resurrecting. Let us welcome him, and, to close this lecture on his many merits, let us for the third and last time call up Gabriel Varden's ghost in repeating his soulful words: "Come! Bring up Toby again, my dear; Dolly shall sing us a song, and we'll all be merrier."

Frankenthal Porcelain.

THE much-mentioned Frankenthal porcelain factory was established in 1755 by Paul Anton Hannong, who was aided by Duke Theodor von der Pfalz. Hannong



FIGURE OF DIANA. FRANKENTHAL PORCELAIN.

brought from Strasburg sufficient experience, but the factory, however, would not prosper, neither was it successful under Joseph Adam Hannong, who assumed charge of it in 1759. Finally the Duke bought it, in 1762, for 50,000 florins. Inasmuch as serious irregularities occurred under Bergdoll, the former modeler and subsequent model master, Simon Feilner was brought from Fürstenburg. He became director of the factory in 1775, and under his management it unquestionably flourished, technically. Nevertheless, the proper outlet could not be established for its product; already in 1780 the subvention furnished by the treasury of the electorate (Carl Theodor had become elector of Bavaria) amounted to 150,000 florins, so that in 1800 Max Josef liquidated it. The models and moulds were sent to Nymphenburg.

In the Frankenthal porcelain the warm, soft white of the mass at once attracts attention. The vessels and services present

nothing extraordinary in form; the decoration very often includes domestic animals and also flowers in copious quantity. The early productions dispense with red, in place of which a violet appears. Later the "scattered flower" decoration was conspicuously prominent, carried out according to Meissen style. It extends also over the robes of the figures, even those of classical design, as a regular fabric pattern, in colors and also in gold, but always on a white ground.

The figures are in most cases very skillfully modeled, the illustration showing a statuette of Diana reposing, the quiver and bow lying at her feet. Luick (Lücke) from 1757 to 1776 was prominent in this work. Peter Melchior, whose activity here dates from 1779, had, as far as can be ascertained, modeled no more figures because during his time they were out of style. Frankenthal ware was distinguished at first by the Palatinate lion, or the initials P. H. F. (Paul Hannong, Frankenthal), then by J. (Josef) H. F., from 1762 by C. T. (Carl Theodor) under a crown, as the mark.

We still possess price lists, dated 1777. The coffee service was constituted as in Meissen. The dinner service resembles ours of to-day, only the "cocoets" attract attention, and the many dishes—28 for 12 persons. The prices for these varied from 576 to 4,228 marks (\$138 to \$1,010). The most expensive were the "battle pieces," the "flying children" and "fine flower festoons," the cheapest the blue paintings, like the "German" and "common Indian" flowers. Among the "moulded goods" there were innumerable cupids, all the months and seasons, senses and arts, gods and muses—these all in various sizes. Also a "pious" Maid of Athens, an "iron" and a "golden" age, a "woman's quarrel" and an "agreement," a shopkeeper and a woman merchant, mechanics, huntsmen, great mythological groups, finally "Chinese houses," "Japanese figures" and all kinds of animals and birds, were included.

It will be noted that the Frankenthal modelers shrank from no undertaking; they possessed, moreover, the remarkable courage of portraying in the "quarreling women" speaking, not to say scolding, likenesses of their better halves. Altogether they appear to have enjoyed great experience of family life, for they have, in some instances, reproduced distinct events in the "training" of children, the knowledge of which they could only have obtained by close observation.

In a decision by Charles P. McClelland, the Board of United States General Appraisers has sustained a claim filed by Austin Baldwin & Co. regarding the classification to be accorded a piece of marble statuary executed by Oreste Bonati, a sculptor, of Carrara, Italy. The work, which represents a group of figures on horseback, was held for duty by the Collector of the Port at the rate of 50 per cent. ad valorem under the provision in the Dingley law for "manufactures of marble." The importers, representing a client, objected to this return, and filed a protest with the Board, alleging that the work should be deemed "statuary" within the meaning of that word as used in the tariff's free list. After a consideration of the evidence the Board upholds the contention of the importers.

The CONE CAP STYLES of Waterman's Ideal Fountain Pen SHOWN IN ALL SIZES

A STAPLE line that will interest more of your trade than any other one line you sell. Everyone who writes is a possible purchaser, and every sale made—in view of the satisfaction resulting—insures additional or continued trade. From tip to tip, the entire pen, is the acme of perfection in craftsmanship. Every pen is guaranteed perfect by us. You can satisfy every writer with a Waterman's Ideal, as the everlasting, iridium-pointed, 14-karat gold pens are made to fit the hand of every writer. The action of any steel pen can be duplicated. The Spoon Feed regulates perfectly an even and well-controlled supply of ink to the very point of the pen, and insures against any overflow, as the pockets retain any surplus.

The Clip-Cap is an individual feature insuring the pen against loss or rolling on any surface. Show cases, display banners, electrotypes, window displays, advertising literature, etc., etc., furnished to dealers.

(Cuts actual size.)



Size No. 12

Style: Plain Black, No. 2 size gold pen
This style in all sizes shown.

No. 12 \$2.50	No. 14 \$4.00	No. 16 \$6.00	No. 18 \$8.00
No. 13 3.50	No. 15 5.00	No. 17 7.00	

Also Chased, Mottled or Cardinal, at same prices.

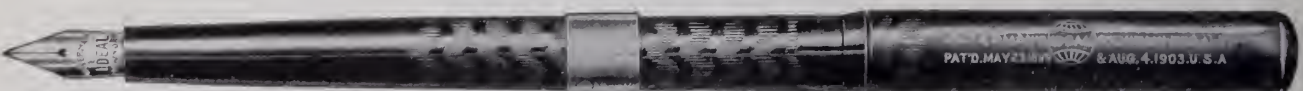

Size No. 13

Style: Chased, Gold Mounted, Plain Middle Band, 18-K. Filled, No. 3 size gold pen.
This style in all sizes shown.

No. 12, G. M. M. . \$3.50	No. 14, G. M. M. . \$5.00	No. 16, G. M. M. . \$7.00	No. 18, G. M. M. . \$9.00
No. 13, G. M. M. . 4.50	No. 15, G. M. M. . 6.00	No. 17, G. M. M. . 8.00	



Size No. 14

Style: Cardinal, with *Clip-Cap, No. 4 size gold pen. This pen used largely for red ink.
This style in all sizes shown.

No. 12 \$2.50	No. 14 \$4.00	No. 16 \$6.00	No. 18 \$8.00
No. 13 3.50	No. 15 5.00	No. 17 7.00	

Also Plain Black, Chased or Mottled at same prices. *German Silver Clips, add 25 cents to all prices.



Size No. 15

Style: Gold-Mounted, Chased Bands, with *Clip-Cap. No. 5 size gold pen.
(Also with two plain bands). This style in all sizes shown.

No. 12, G. M. . . \$3.50	No. 14, G. M. . . \$5.00	No. 16, G. M. . . \$7.00	No. 18, G. M. . \$9.00
No. 13, G. M. . . 4.50	No. 15, G. M. . . 6.00	No. 17, G. M. . . 8.00	

*Gold-Filled Clips add \$1.00 to all prices; Solid Gold Clips add \$2.00 to all prices.

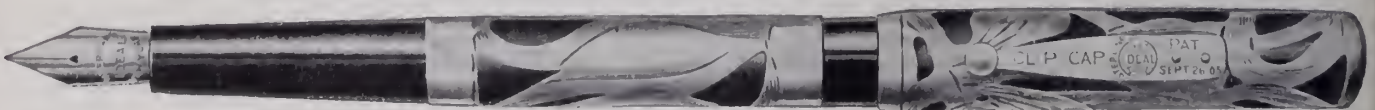

Size No. 16

Style: Filigree, Sterling Silver, with *Clip-Cap. No. 6 size gold pen.

No. 412, Fil. . . \$5.00	No. 411, Fil. . . \$7.00	No. 416, Fil. . . \$9.50	No. 418, Fil. . . \$12.00
No. 413, Fil. Not made	No. 415, Fil. . . 8.50	No. 417, Fil. . . 11.00	

Mounted on Black or Cardinal Holder. *Sterling Silver Clips add 50 cents to all prices.

Made in two larger sizes, Nos. 17 and 18. Write to-day for complete Catalogues, information and suggestions.

L. E. Waterman Co., = = 173 Broadway, New York

CHICAGO

BOSTON

SAN FRANCISCO

MONTREAL

LONDON

The Difference Between Earthen Ware and China.

THE difference between china and earthen ware is not generally understood, even by those who make its purchase and sale their life's vocation. Many a dealer has been sorely perplexed when asked the question, the majority usually replying that one is translucent and the other isn't. As a matter of fact, translucency proves nothing, or some earthen ware is so thin that it possesses this quality, and some china is so thick as to lack it entirely.

Every piece of ware claiming to belong to either one of these divisions needs only to be broken to show in itself the evidence that will decide the question to which class it belongs. Upon the surface they often resemble each other, and even an expert may be deceived (although in appearance there is a difference to the practiced eye); but if one can see the body, anyone may decide for himself. A year's use in service will also furnish a practical test, as in earthen ware the glaze being on the surface, if the piece be chipped the grease is absorbed by the porous body beneath and becomes black and unsightly, which cannot happen to a hard porcelain dish, it being vitrified throughout.

True china, or porcelain, is that ware in which the glaze has penetrated every pore of the body and has become an integral component of it.

Earthen ware breaks with a rough fracture, exhibiting the color of the clay; porcelain breaks with a vitreous fracture, white and clean.

The various kinds and grades of earthen ware are distinguished by the granular or chalky surface of the fracture, instead of the vitreous fracture of porcelain, the former resulting from the absence of the degree of fusion necessary to produce vitrification.

The biscuit of earthen ware is very hard, ringing when struck, and so porous that it will absorb water rapidly.

The first firing of china is at a much lower heat than that of earthen ware, converting the material into a soft instead of a hard biscuit, and is conducted in the upper story of the porcelain kiln. The biscuit is then dipped into a glaze composed of ground quartz or flints, feldspar, lime and clay, which fuses at a white heat and fluxes with the body of the ware so as to form with it as well as upon the surface a vitrified translucent mass which will not check or craze upon the surface when subjected to variations of temperature.

The difference in manufacture between China and earthen ware is this: Earthen ware is fired very hard in the biscuit, and then by a dull red fire the glaze is fastened on the outside of the ware; while in china the biscuit is merely dried in the kiln sufficiently to handle, and the glaze penetrating every pore, the completed piece is subjected to the most intense heat known, fusing the entire mass and vitrifying the substance completely, thus rendering it impervious to grease and not affected by changes in temperature.

Earthen ware is fired at a degree of heat

varying from 300° to 1,000° F., while the final firing of porcelain is at about 3,000°. A knowledge of this fact will explain many points before incomprehensible. It is often asked: "Why is it that they cannot make as straight dishes in French china as the earthen ware manufacturers do?" The reason is obvious: The more intense heat of the porcelain kiln warps the rims of oval dishes to such an extent that a perfect one never has been made, and probably never will be; while the great piles of seconds dishes of the larger sizes to be found in every factory furnish an answer to another inquiry often heard, viz., "Why do large oval dishes cost so much?" On the other hand, in the kiln of the earthen ware manufacturer the lesser degree of heat required to fasten the glaze on the exterior is not sufficient to affect the shape of the piece. Hence, we see that a seeming defect is in reality the proof of greater value. Perfectly straight, flat ware would delight the eye alike of manufacturer and purchaser, but it would be at the expense of real intrinsic value. Almost every factory possesses specimens showing the effect of the intense heat of the porcelain kilns. One piece is a sauce tureen, the body and cover having melted and settled into the stand. Another, a compotier, with edges curled over all around and hanging as does the snow from the roofs of our houses in Winter. A third is the body to a casserole, with its support (or rim on which it is fired). The former has melted in folds, the foot dropping in the center until the appearance of the whole reminds one of the "crush" hat affected by the masculine wall-flowers of the opera or ball season. Plates twisted into every conceivable shape; individual butters with the edges blistered; whole piles of saucers fastened one to another, etc.

This fact of the intense heat also explains another point upon which much mystification seems to exist. Dealers have often asked: "Why is porcelain never glazed on the bottom, as earthen ware is?" Recall the great degree of heat, and you will see at once that the piece would fasten itself immovably to sagger, furnace, or any article or substance with which it should come in contact. This sometimes happens even when the foot (as in a plate) is left unglazed, for the center will sink a trifle and by touching the sagger ruin itself completely. In the manufacture of earthen ware, "spurs," or little pointed supports, are used for this purpose, and the little marks on the rims of plates are caused by these, which cannot be used in the making of porcelain, as, the ware being thinner and the heat greater, all the pieces would come from the kiln in a "ramshornical" shape.

In covered or hollow ware we find the same cause leading to like trouble. The rims of body and cover cannot be glazed in porcelain, and the rough surface often gets soiled (not discolored, which cannot occur). Therefore customers say: "I wish you would glaze your covered pieces as the crockery men do." This arises from the fact

that in the oval ware, like soup and sauce tureens and covered dishes, the cover must be "fired" on the body in each instance, so that when one warps, as is often the case, the other will assume the same form, and thus they fit each other. Were they "fired" separately the body might fall in a little at the center or elsewhere, while the cover expanded at the same point, and the manufacturer would have very few that would match. The point of contact must be left unglazed to prevent the two sticking together; and to still further avoid this calamity the foot is often placed on a bed of some infusible substance, like sand or powdered quartz, and a paste of the same nature is applied to the edge and rim of cover and dish. This is the reason why orders for covers only cannot be filled.

Now, in conclusion, a few words of moral application. First, to the manufacturer and seller: Don't sell earthen ware under the name of "china," even if preceded by some qualifying adjective. When a customer writes ordering "covers only," don't curtly answer, "We can't sell covers alone"; or, in reply to a complaint that "your china is very crooked," tell him "it is the best we have got," for a few words of explanation will often prevent unpleasant misunderstandings, and enable the buyer to understand how it can be that the best china (owing to the use of better clay and harder fire), is more apt to be crooked and spotted with iron than its competitors of lower grade. On the other hand, let the buyer understand the principles of manufacturing, and he will not be so ready to write to the seller that "The last lot of dishes sent were all 'seconds,' and are here subject to your orders," for he will know that perfect goods cannot be made. Neither will he, when refused "covers only," think it only unwillingness to oblige on the part of his correspondent, who "might have sent them if he had chosen to do so," but will avoid the necessity of a refusal by explaining to his customer in advance that they cannot be procured.—*Crockery and Glass Journal*.

Etching on Glass.

ATTRACTIVE signs can be etched on glass by anyone handy with the brush and pencil, says the *Pottery Gazette*. The materials of an etching fluid consist of sodium fluoride, nine drams; potassium sulphate, 108 grains; water, 16 fluid ounces. Make a solution and label No. 1. Zinc chloride, 216 grains; concentrated hydrochloric acid, 10 fluid drams; water, 16 fluid ounces. Label solution No. 2. Method: Mix equal quantities of the solutions in a gutta percha or leather vessel, or in a glass vessel, the interior of which has been covered with a layer of paraffin or in a hollow in a piece of paraffin wax.

Of course, any less quantity may be prepared in the given proportion, when the liquid is applied to the cleaned surface of the glass sign by means of a glass rod, glass pencil or a hard rubber pencil.

Walter Grunert, Green Bay, Wis., recently sustained a loss of \$500 by fire.

The Vincennes Novelty Mfg. Co. is a new concern in South Bend, Ind., having moved recently from Vincennes, Ind.



Enough metal is often lost in the careless reduction of
Filings, Waste, Scraps and Sweeps

to cover the cost of the work. We are careful and considerate enough to overcome this loss, thus enabling you to meet the expense out of a surplus that is ordinarily lost.

Try us and see if it isn't so

No. 236 Eddy St., **CONLEY & STRAIGHT,** Providence, R. I.

Gold and Silver Refiners, Assayers and Sweep Smelters, Dealers in Fine Gold, Silver and Platinum, all kinds of Gold and Silver Anodes.

UNITED STATES SMELTING AND REFINING WORKS

L. & M. WOLLSTEIN

16 JOHN STREET, NEW YORK

SWEEP SMELTERS AND ASSAYERS

Dealers in Gold and Silver Assay Office Bars. **HIGHEST** and **MOST PROMPT RETURNS** made for Sweeps and all kinds of Waste containing precious Metals.

HIGHEST PRICES PAID FOR OLD GOLD AND SILVER

Manufacturers of **STERLING SILVER.**

Importers of **PLATINUM.**

Ore and Bullion Assays a Specialty.

Frank Dederick.

Established 58 Years.

James E. Dederick

James H. Dederick's Sons,
Assayers and Bullion Dealers.

All qualities of Gold and Silver, in Plate, Square and Round Wire, Rolled to any gauge. We are selling fine gold for \$1.04 per dwt. which we guarantee to be government assay bars. Small rolling for the trade.

ALL QUALITIES OF GOLD AND SILVER SOLDER.

16 Maiden Lane **NEW YORK.**

We buy Old Gold and Silver.

Do You Know Why

Gravers sharpened with the

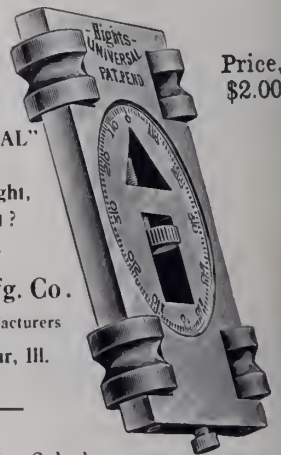

Price, \$2.00

"UNIVERSAL"

leave a bright, smooth cut?

Hight Mfg. Co.

Sole Manufacturers

Decatur, Ill.

For Sale by

A. C. BECKEN CO., Chicago, Ill.
 SWARTCHILD & CO., Chicago, Ill.
 E. & J. SWIGART CO., Cincinnati, O.
 F. J. BOESSE & CO., New York.
 NORDMAN BROS. CO., San Francisco, Cal.
 LEONARD KROWER, New Orleans, La.

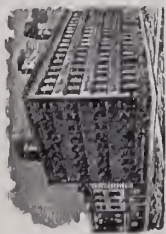

L. LELONG & BRO.

Gold and Silver Refiners, Assayers and Sweep Smelters

S. W. Cor. Halsey and Marshall Sts., **NEWARK, N. J.**

Prompt attention given to Gold and Silver Bullion.

SMELTING FOR THE TRADE.

ESTABLISHED 1886

GEO. M. BAKER

TELEPHONE UNION 1493-R

Gold and Silver Refiner and Sweep Smelter

Office, 91 Page St. } **PROVIDENCE, R. I.**
 Works, 77-85 Page St. }

Our processes are strictly up to date and facilities most complete for doing all kinds of refining.
 Specialties: Prompt and good returns.

WM. BOLLES' SELF-FILLING NON-LEAKABLE FOUNTAIN PENS



SIMPLE—CLEAN—PRACTICAL

We make our own goods—and they have stood five years' test by the largest dealers in the country. Write for Catalogue and Price Lists.

THE WM. BOLLES CO., 1108 JEFFERSON ST., TOLEDO, OHIO

HERE IS A DUST COLLECTOR *You ought to have it*

That will collect every particle of dust and material that comes from your polishing machines, and in a

PERFECTLY DRY STATE

90%

Guaranteed Saving. Isn't it worth having?

DETAILS UPON REQUEST

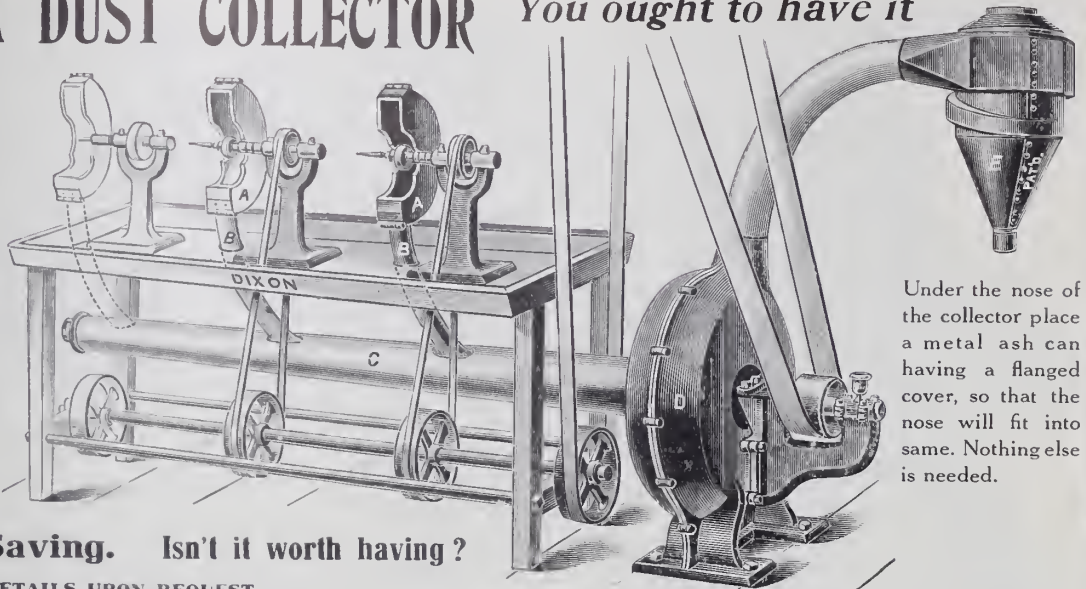

Under the nose of the collector place a metal ash can having a flanged cover, so that the nose will fit into same. Nothing else is needed.

WILLIAM DIXON, Incorporated

FORMERLY
F. W. GESSWEIN
COMPANY

**39 JOHN STREET
NEW YORK**

WM. F. RENZIEHAUSEN CO.

43-47 Oliver Street, NEWARK, N. J.

'Phone 3759-R.

Gold and Silver Refiners

PROMPT RETURNS MADE FOR ANY MATERIAL CONTAINING PRECIOUS METALS
DEALERS IN GOLD AND SILVER, AND ROLLERS OF STERLING SILVER

Gold and Silver Anodes a Specialty

WHY NOT SEND YOUR SWEEPS DIRECT TO THE SMELTERS?

LEES & SANDERS, BIRMINGHAM, ENG.

Our plant is right up-to-date and specially arranged for smelting jewelers' sweepings.

SEND ON AN ENQUIRY FOR REFERENCES ON YOUR SIDE.

ESTABLISHED IN 1870.



WE BUY

Old Gold and Silver Filings, Polishings, Sweeps, Hand Washings, etc. We will make accurate valuations and hold consignment subject to your acceptance. If valuation is not satisfactory, we reship to you at our expense.

WE PAY FOR OLD GOLD:

22 K. 88c. per dwt.	12 K. 48c. per dwt.
20 K. 80c. " "	10 K. 40c. " "
18 K. 72c. " "	8 K. 32c. " "
16 K. 64c. " "	6 K. 24c. " "
14 K. 56c. " "	4 K. 16c. " "

MARKET RATES FOR SILVER AND PLATINUM.

Try us and you will Appreciate our Squareness, Promptness and Accuracy.

T. B. HAGSTOZ, Ltd., Main Office, 709 Sansom St., Philadelphia, Pa.
SMELTERS, ASSAYERS, REFINERS.

WE SELL

Gold, Silver and Platinum, various qualities, rolled flat or drawn to wire of any gage.

PRICES OF ALLOYED GOLD:

8 K. 42c. per dwt.	14 K. 66c. per dwt.
10 K. 50c. " "	16 K. 74c. " "
12 K. 58c. " "	18 K. 82c. " "

Gold and Silver Solder, either from formulas furnished, or our own, "T. B. H." Alloy, 25c. per oz. Guinea Gold, 75c. per lb. Shot Copper, 40c. per lb. We will send tables for alloying without charge. They save figuring.

The Ackley Engraving Block

AND "JOKER" ATTACHMENT



Pat. March 20, 1906
 Made by Engravers who saw the need
 of a Handy Time Saving Block

THE BEST IS THE CHEAPEST

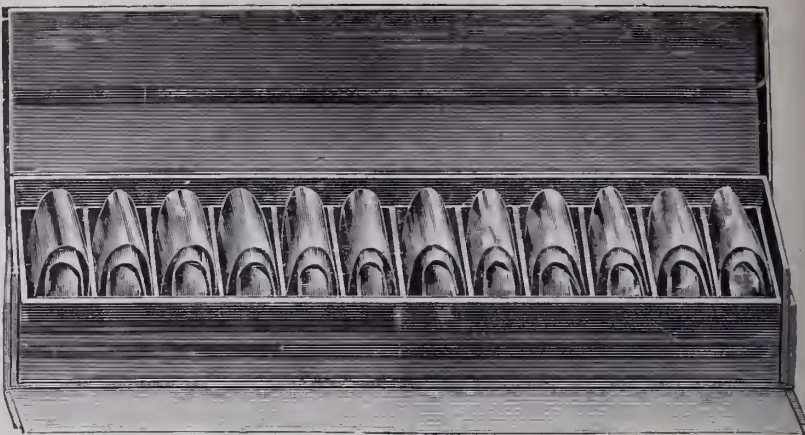

Why the "LAFAYETTE MAINSPRING" is superior

1st—It is guaranteed to be made of the Best Steel. 2d—It is made by Skilled Hand Labor. 3d—Each Spring is wrapped in Oil Paper and Silver Foil, which packing positively avoids exposure to the moisture of the air, and therefore all danger of rust is prevented. 4th—Each Spring bears a metal Tag, indicating the watch it is intended for, which accuracy is warranted. 5th—Each dozen is put up in a neat Box, having twelve partitions, one for each spring, so the handling of several springs at one time is avoided. 6th—The finish of the "Lafayette Spring" is, like its quality, superior to any in the market.

THE ACKLEY ENGRAVING BLOCK: Always ready to hold any article. No hunting for pins. The patent friction pins all remain in the head. Simply pull up to the desired height the ones needed. Each pin is numbered on top to designate size of groove or notch in it. They are so arranged in the head that they will readily hold all large or small articles either by three or more points of contact. The swivel jaw can be locked rigidly in an instant. The key will not fall off, yet it may be removed instantly. The patent base eliminates all unnecessary weight and gives the same movement as the old ball and socket base. This block is the result of years of practical experience of engravers who know the wants of engravers. There is nothing complicated about it to wear out or get out of order. Workmanship and materials are the best. Each part is copper plated before being heavily nickel plated, thus insuring a fine durable finish. Height, 6 3/8 inches. Diameter of head, 2 3/4 inches. Diameter of base, 6 inches. Weight, 8 pounds. **THE "JOKER" ATTACHMENT,** as shown beside the block, holds large and small signet and band rings, cuff buttons, collar buttons, signet pins, etc., firmly, without marring. It may be used on any block.

HENRY ZIMMERN & CO., Inc., 77 John Street
 New York City
 Exclusive Wholesale Distributors for U. S. and Canada

LEIMAN'S NEW SAND BLAST

SIMPLE
 EFFICIENT
 ECONOMICAL

Short, Straight Feed Pipes—CAN'T CLOG UP
 Continuous Automatic Sand Feed—For RAPID
 WORK IN LARGE QUANTITIES

LEIMAN'S HIGH PRESSURE BLOWER

RUNS SMOOTH AND NOISELESS
 Greatest Volume No Springs or Delicate Parts
 Highest Pressure to Get Out of Order

SEND FOR CATALOGS

LEIMAN BROS.

Brill St. and Bonykamper Ave., NEWARK, N. J.
 139-143 Centre St., NEW YORK, N. Y.

Manufacturers of Jewelers', Silversmiths' and Metal Workers'
 Machinery, Tools, and WORK BENCHES—Plants Equipped

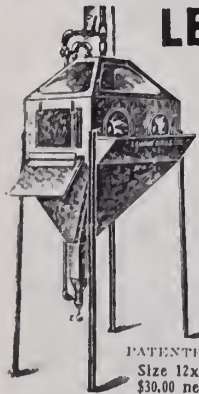

PATENTED
 Size 12x15
 \$30.00 net.



PATENTED

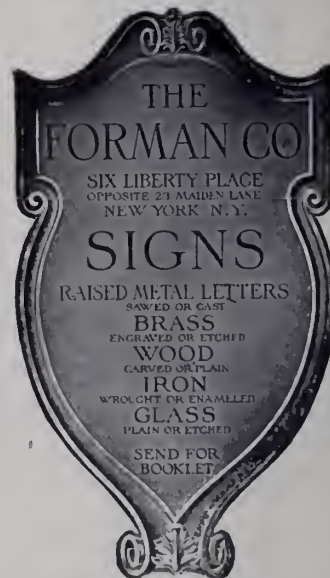

THE
 FORMAN CO

SIX LIBERTY PLACE
 OPPOSITE 23 MARSHALL LANE
 NEW YORK N. Y.

SIGNS

RAISED METAL LETTERS

SAWED OR CAST

BRASS

ENGRAVED OR ETCHED

WOOD

CARVED OR PLAIN

IRON

WROUGHT OR ENAMELLED

GLASS

PLAIN OR ETCHED

SEND FOR
 BOOKLET

Established and
 in business since
 1894

OUR BUSINESS

DIES

We have been giving
 satisfaction for
 the past 14 years.

FINE DIE WORK IS ESSENTIAL FOR FINE JEWELRY, SILVERWARE, ETC.
 Write us and let us submit for your approval a selection of original designs, made especially to suit your needs.

CREES & COURT Die Sinkers and Designers
 21 Eddy St., PROVIDENCE, R. I.

JOHN AUSTIN & SON

Assayers, Refiners and Smelters

74 & 76 Clifford Street PROVIDENCE, R. I.

We Do Our Own Smelting.



ARTHUR MARSON INC.

MAKERS OF

Swivels, Spring Rings, Snaps and
 Specialties in the Line, in GOLD
 and PLATINUM

Manufacturers of the
 SMALLEST SPRING RING
 on the market for Neck Chains

SEND FOR SAMPLES

23 MARSHALL ST., NEWARK, N. J.

**Combination
Pallet Stone
and
Jewel Pin
Setter No. 70.**

Price \$2.50

Directions how to use
enclosed with each
tool

**THE ELY WATCH
PROTECTOR**

Price per
dozen \$2.00

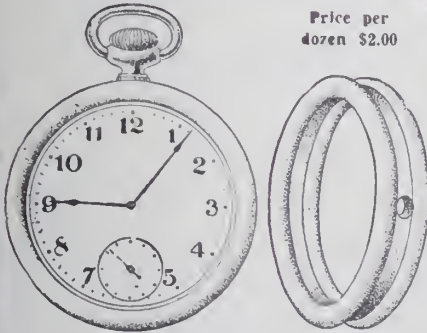

Designed to give the maximum "cling" on the lining of the pocket, with the least possible bulk. Scientifically correct. Made from soft, yielding rubber, treated by secret process to prevent it from tarnishing gold or filled cases. No hooks, fastenings or other annoyances. Fits the rim under tension, sealing the joints of the case. Excludes dirt and moisture. Foils pickpockets. Saves hard knocks. The best preventative against dropping watch out of pocket when worn with a foh chain.

Made for 18, 16, 12 and 6 size open face watches.

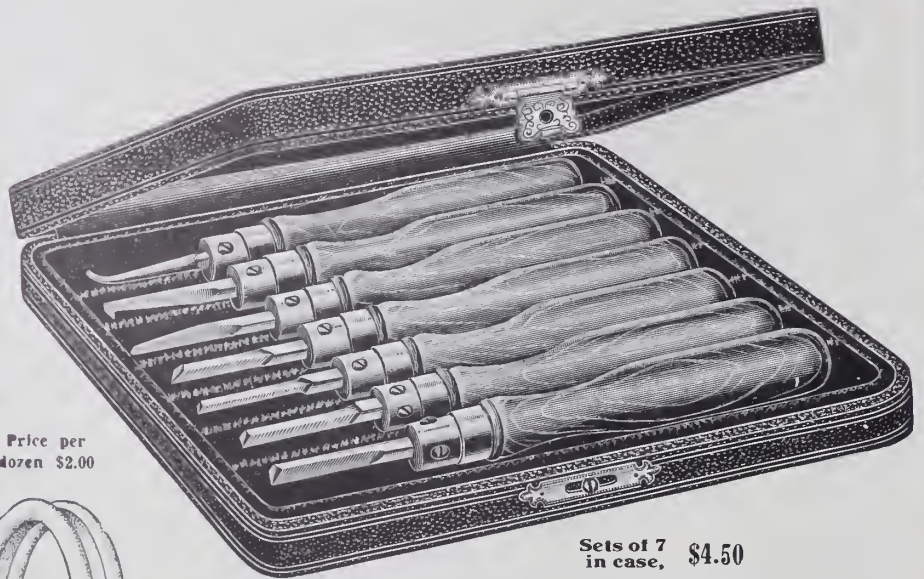

Sets of 7
in case, \$4.50

Guaranteed E. F. B. Turning Gravers No. 34

The finest set of gravers on the market. Handles are of finest cocobolo, fitted with nickel plated sockets, in which the gravers can be moved in or out as required. The two set screws hold the graver rigid and prevent rocking or chattering. They will be appreciated by all users of good tools.

Spectacle and Eyeglass Strap Plier No. 105

Price, each, \$1.25

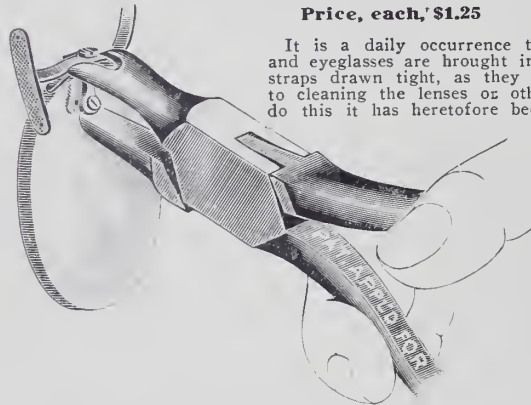

It is a daily occurrence that frameless spectacles and eyeglasses are brought in to have the small side straps drawn tight, as they have become loose, due to cleaning the lenses or other causes. In order to do this it has heretofore been necessary to remove the lenses from the mountings, and as all know, this very often results in breaking or chipping the lenses.

By the means of this plier this can be avoided and the work quickly done.

All that is required is to loosen the screw two or three turns, clamp the frame as shown in the illustration, and bend the straps to the lenses. Retighten the screw, and the work is done.

DO NOT NEGLECT to loosen the screw, as otherwise a good job cannot be done, and the lenses are likely to be broken.
Made of best quality Swedish steel, nickel-plated.

**Claw Stretching and Repairing
Plier No. 95**

This Plier should find ready favor with all jewelers, considering only the saving of time when repairing a broken or worn setting.

Made of best Swedish steel finely nickel-plated. Each, \$1.25

DIRECTIONS:

For repairing worn settings, place slotted jaw on the outer side of the setting and the ball-tipped one on the inner side, pulling from or pushing against the setting, as occasion may require, all the while pressing the handles of the plier firmly together.

With little practice, any jeweler can easily repair a worn-out Tiffany or skeleton setting, or draw out a broken claw as good as new, in less than five minutes.

Unequaled for shaping ordinary settings for Moonballs, Whole Pearls, or any round stone.

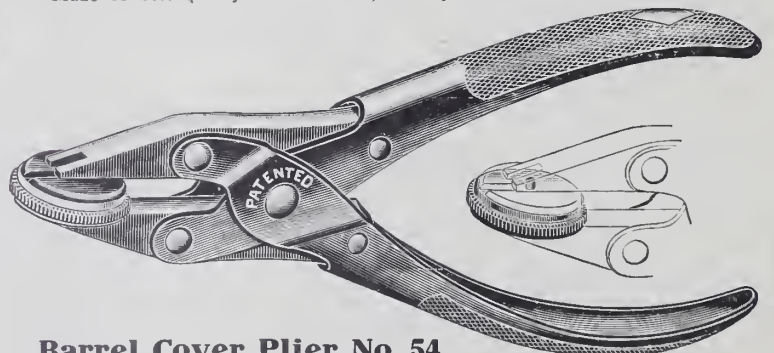

Barrel Cover Plier No. 54

The jaws of this Plier are provided with two circular disks of German silver; both of which are slotted or cut out to admit the longest barrel arbor made. The risk of bruising or scratching the barrel cover is eliminated by the use of this plier. The jaws being parallel, the pressure on the cover is even and full control over the work is possible.

Price, each, \$1.25

FOR SALE BY ALL JOBBERS IN THE UNITED STATES AND CANADA

HAMMEL, RIGLANDER & CO.

47-49 Maiden Lane
New York

STERN

BROS. & CO

DESIGN
FINISH

WORKMANSHIP
QUALITY

A NEW LINE FOR THE = SPRING TRADE =

AT POPULAR PRICES

Rings, Brooches, Locket, Scarf Pins, Bracelets, Fobs, Studs, Crosses, Link Buttons, Hat Pins, Baby Pins, Thimbles, Tie Clasps, Screw Earrings, Ring Mountings, Bead Neck Chains, Charms, Festoons, Emblem Goods, Match Boxes, Neck Chains, Cigar Cutters, Pocket Knives,

VEIL PINS

Lapel Buttons, Vest Buttons

STERN BROS. & CO. 33-43 GOLD STREET
NEW YORK

Manufacturers to the Jobbing Trade Exclusively

Salesrooms and Offices of the Diamond Department:
68 Nassau St., New York.

Diamond Cutting Works: 142 West 14th St., New York.

BRANCH OFFICES—Chicago, Illinois: 103 State St.

London, England: Audrey House, Ely Place.

Amsterdam, Holland: 12 Tulpstraat.



THE JEWELERS' CIRCULAR

WITH WHICH ARE CONSOLIDATED

THE HOROLOGICAL REVIEW,

THE JEWELERS' WEEKLY,

THE JEWELERS REVIEW

Copyright 1908 by
The Jewelers' Circular
Publishing Company.

11 John St., Corner Broadway, New York.

Entered as second-class matter at the New York, N. Y., Post Office.

40th Year.

WEDNESDAY, FEBRUARY 12, 1908.

Vol. LVI. No. 2.



Two Views of Regatta Trophy Presented by Mr. and Mrs. Andrew Carnegie to Princeton University.
(See Text on Page 41.)

ALVIN SILVER "FLEUR-DE-LIS"
(Flower of the Lily)



ALVIN-MFG-CO
SILVERSMITHS
NEW YORK, 52 MAIDEN LANE

THE ABOVE ILLUSTRATION represents the cover of our New Catalogue showing the Fleur-de-Lis Flat Ware pattern. The catalogue illustrates the full line of ounce goods, fancy pieces and cutlery which, owing to the reduction in cost of silver bullion, are offered at reduced prices. If you have not received a copy, write us for it.

ALVIN MFG. CO., Silversmiths, NEW YORK

Fahys

Usually the best costs more.
Not so when you buy Fahys
Gold Filled Watch Cases,
which sell for the best, are
the best, and the Jeweler is
sure he is getting full value
for what he pays.

All of Fahys Cases are made
with our patent one-piece
pendant, which eliminates
all solder.

JOSEPH FAHYS & CO.

New York

Chicago

Boston

San Francisco

A FINE LINE *of* DIAMONDS

Diamond Cutters
 Private Lake
 —
 Fine Fishing
 for
 Retail Jewelers

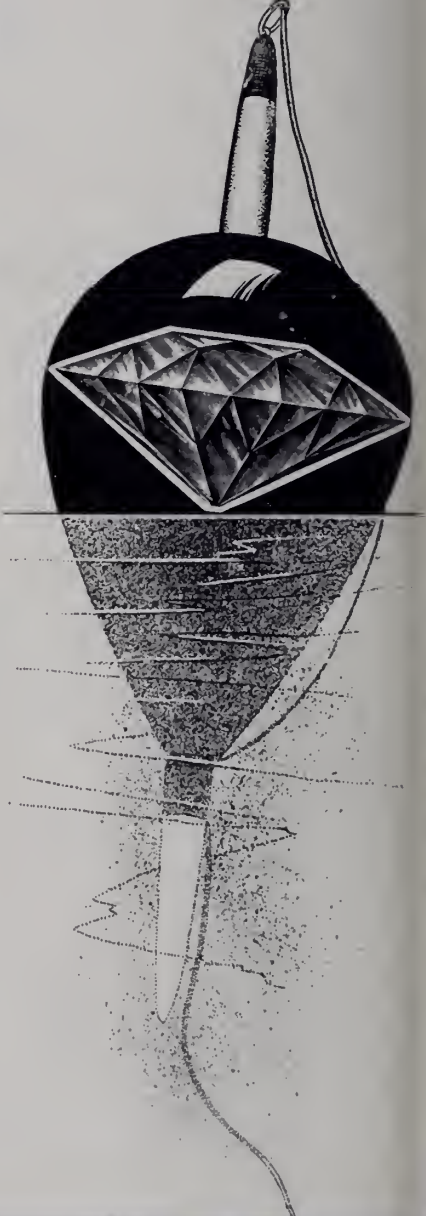
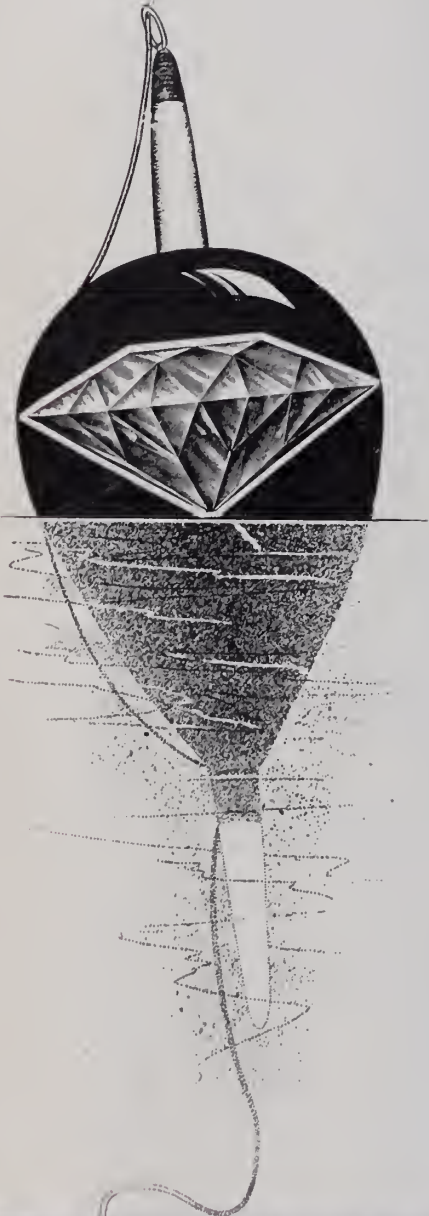

Investigation
 Will Quickly
 Demonstrate
 That Fishing
 in These
 Waters
 Pays Well

J.R. WOOD & SONS

The INVITATION

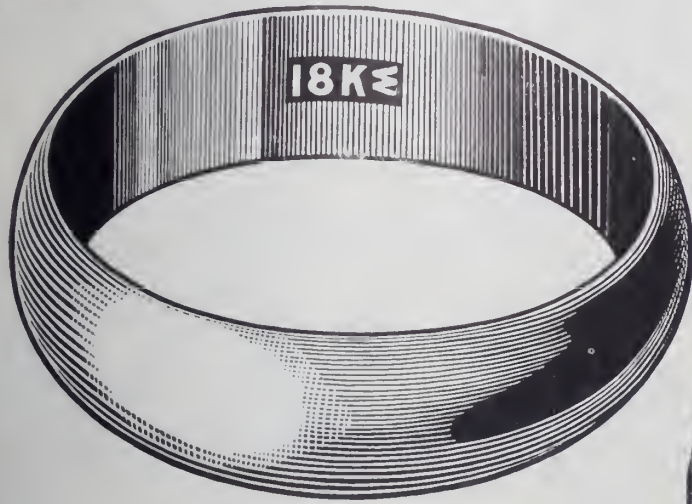

WE INVITE YOU to purchase the best wedding rings made — wedding rings of our manufacture; fully guaranteed as to plump quality and perfect finish.

With all their excellence, our prices are the lowest.

J. R. WOOD & SONS

WEDDING RING MAKERS

2 Maiden Lane, Corner of 170 Broadway
NEW YORK



NEW Goods every week. Our line contains every kind of chain and fob worn by men and women. Our new Hinge Bracelet, the Beulah, in all widths, oval and square, is pronounced the best hinge bracelet on the market. All sizes and styles are made both in side swing and hinge. Our locket fob for ladies is the proper thing.



S. O. BIGNNEY & CO.,

ATTLEBORO
MASSACHUSETTS

NEW YORK OFFICE: 3 MAIDEN LANE.

Illustration
about
four-fifths
actual size



WE have one hundred styles of Ring Mesh Bags. Our New Mesh Bag, the Elite, is a beauty, very flexible.

We are headquarters for Mesh Bags this season.

BRISTOL MANUFACTURING CO.,

ATTLEBORO
MASSACHUSETTS



No. 69.



No. 48.



No. 40.



No. 61.



No. 64.



No. 63.



No. 71.



No. 67.



No. 73.



No. 51.



No. 44.



No. 66.



No. 99.



No. 22.

When you DO have a call for a fine Emblem Ring it is well to know that Wendell & Co. make the only line of high grade 14K. Rings on the market, that they carry a complete stock and gladly send a selection on memo. Their catalog shows illustrations of the entire line with list prices. They also make special Emblem Rings to order.

WENDELL AND COMPANY

The Special Manufacturers for the Retail Jewelry Trade

103-105 WILLIAM STREET, NEW YORK

57 WASHINGTON STREET, CHICAGO

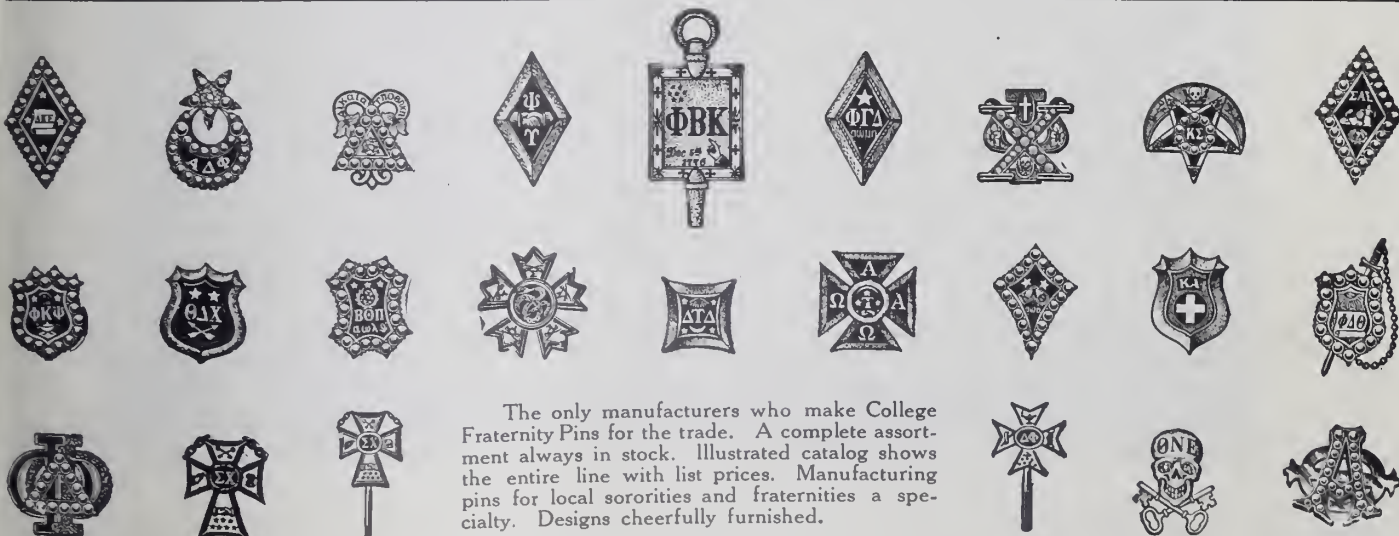

The only manufacturers who make College Fraternity Pins for the trade. A complete assortment always in stock. Illustrated catalog shows the entire line with list prices. Manufacturing pins for local sororities and fraternities a specialty. Designs cheerfully furnished.

The Big Dipper

Will Dip Up Profits For You



THE
BEST IN EVERY
GRADE

CHICAGO
701 Heyworth Bldg.

Ask your Jobber

NEW YORK
Maiden Lane

STARWATCH CASE CO.

LUDINGTON, MICHIGAN

COPYRIGHTED BY T. F. KENNEDY

JUST THE SAME AS EVERLASTING

ALL things must yield to Father Time—nothing is indestructible.
Yet it is quite true that

WADSWORTH PERMANENT

watch cases are “just the same as everlasting,” for they will wear so much longer than anybody expects them to that, in the end, they will be carefully laid away to be cherished with the other family heirlooms.

Chaste and artistic in design, perfect in workmanship and truly permanent, they represent the maximum of value, salability and satisfaction.

They would cost more if they were solid, but they would be no more attractive, nor would they give better service.

The Wadsworth Watch Case Co.

FACTORY
DAYTON, KY

CHICAGO
COLUMBUS BUILDING

SAN FRANCISCO
717 MARKET STREET

NEW YORK
49 MAIDEN LANE

Late
 Attractive
 Designs
 (25 YR. 14 K.)



The
 Four Hundred
 Series

THE Dueber-Hampden
 Watch Mfg. Co.
 CANTON OHIO.

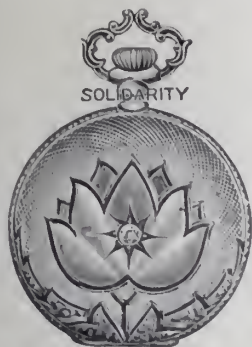

MARGUERITE



MARGUERITE

Mr. Retailer :

CERTAINLY we are forging ahead. So long as boys grow to be men, and girls to be women, so long will WATCHES be a NECESSARY luxury.

Millions of watches will be sold in 1908

and

SOLIDARITY GOLD WATCH CASES will be one of the most important factors in determining the LUXURY of these necessities.

Your jobber will supply them.



Solidarity Watch Case Company

Established 1885

54 Maiden Lane, New York

General Selling Agents :

JOHN W. SHERWOOD

:::::

FRANK E. HARMER

Buckles



OUR BUCKLES are dress accessories that beautify what is already pretty in apparel. They constitute a welcome addition to the plainest garments or meet the strangest caprices of a strangely capricious sex—such are the volume and variety of our line. The range develops from buckles of Puritan simplicity to those elaborate curves and scrolls affected at the present time. All designed within the bounds of propriety, and calculated to please alike the exacting and indifferent. Etched, Plain, Fancy Die and Hand Engraved. Illustration, No. 2896, actual size; No. 2897, smaller size, same design. We also make these in belt pins. Sterling Silver of substantial weight.

Established 1861

R. BLACKINTON & CO.

TRADE  MARK

SILVERSMITHS

3 Maiden Lane, New York

Factory: North Attleboro, Mass.

WHITING MFG. COMPANY

Silversmiths



The Outlook

To form a clear and discerning forecast of the probable course of business during the coming year is of vital consequence to every Retail Jeweler.

The timidity bred of an undue pessimism, is as mischievous in its consequences as the rash confidence resulting from an overweening optimism.

The Whiting Company's intimate knowledge of existing conditions, in all sections of the country, is of such a nature as to have encouraged them to make special efforts to meet the already growing demand for goods of acknowledged excellence.

The far-seeing Jeweler, therefore, when replenishing his stock, will give attentive consideration to the established reputation of *Whiting Silverware* for convincing quality and attractive design.

Broadway and Nineteenth Street
New York



Chafing-Dish, No. 1119, with
Genuine Stag-horn Trimmings

Increased Profits

for you during 1908 will greatly depend on your ability to select for your stock such articles as are timely for timely occasions.

The successful jeweler carries, in addition to his line of jewelry, articles suitable for the household.

The Sternau Chafing-dish is a necessary household commodity and sells throughout the year. It is only one of our many specialties. Write for our Catalogue Z.

S. STERNAU & CO.

Makers of Coffee-machines, Fancy Teakettles,
Chafing-dish Accessories, Smoking Sets,
Candlesticks, Coffee and Tea
Pots, Butlers' Trays, etc.

New York Showrooms
BROADWAY, COR. PARK PLACE
Opposite Post-office



Office and Factory
195 PLYMOUTH STREET
BROOKLYN, N. Y.

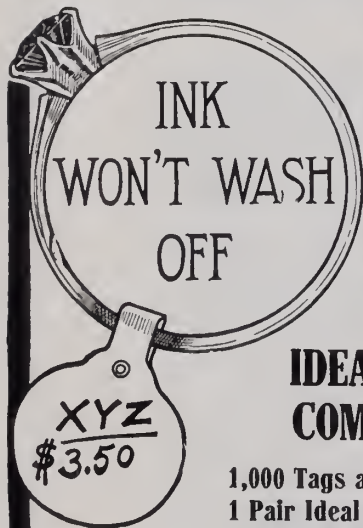

TAG YOUR RINGS WITH WASHABLE TAGS

IDEAL TAGGING OUTFIT COMPLETE, ONLY \$2.50

- 1,000 Tags and Eyelets, . . . \$1.50
- 1 Pair Ideal Pliers,75
- 1 Bottle Waterproof Ink,25
- 1 Neat Hardwood Box, with catch fastener

The IDEAL CELLULOID TAG is something that every jeweler should have, BECAUSE IT SAVES TIME—AND SAVES MONEY.

And because it gives your rings a more attractive appearance.

You don't have to take off the tags when you wash or polish your rings, because the ink that goes

with each outfit is waterproof, and won't wash off. No danger of getting the tags mixed and getting them on the wrong ring.

The Ideal has a large flat writing surface, which makes it better than any other tag.

A complete outfit only costs \$2.50. Better send for it to-day if you want it soon, for the demand is very large.

Bastian Bros. Co.
30 South Avenue, ROCHESTER, N. Y.

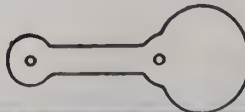

POSITION OF TAG
WHEN RING IS IN TRAY

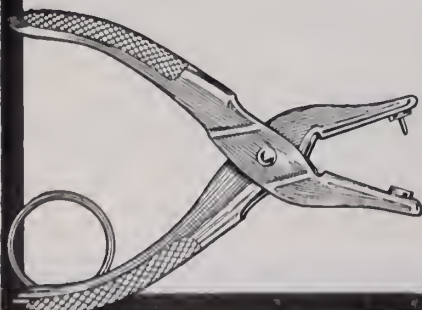

O. M. Draper Chains

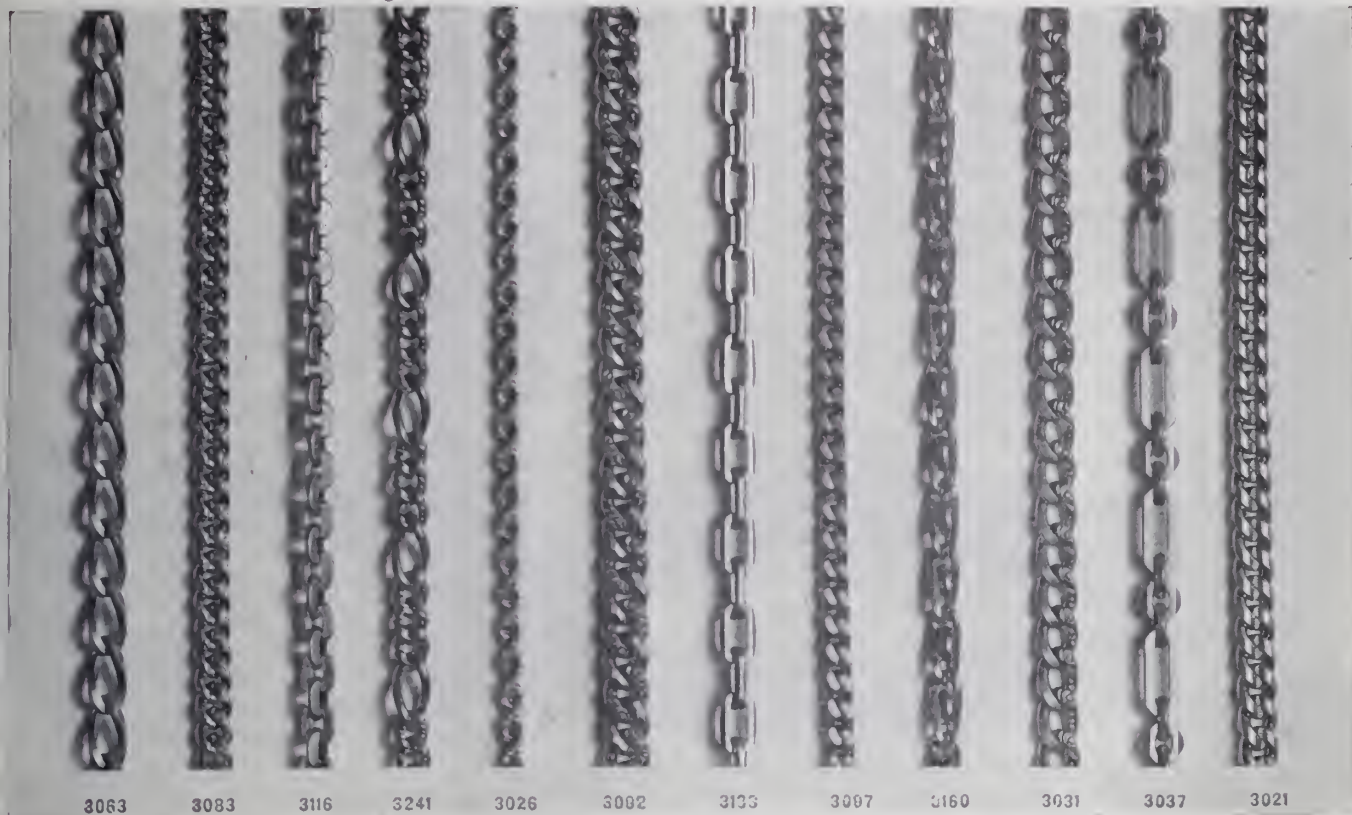

There is no surer method of increasing your sales and consequent profit for the year 1908 than by adding to your stock a thoroughly **satisfactory** line of chains.

A chain to be satisfactory must not only be guaranteed in every particular, but must be in and of **itself** a guarantee and **give** satisfaction to the wearer.

For nearly half a century the **O. M. Draper Chains** have fulfilled all these requirements.

Our Motto: SUPERIOR QUALITY, ARTISTIC DESIGN, UNPARALLELED FINISH.

We show above a few of the large variety of patterns of our one-tenth seamless gold filled line. Ask your jobber for them.

“O. M. D.” Adjustable Bracelet

Our Bracelet is a distinct innovation as far as Extension Bracelets are concerned. All of the defects common to Bracelets of this sort are eliminated in the “**O. M. D.**” **Adjustable**. No pins or rivets are used in its construction; parts are securely locked together, and no solder is used, which leaves the gold hard and preserves its wearing qualities. Repairs are reduced to a minimum. The Bracelet is made of extra heavy gold filled stock, is reversible, flexible and firm, and is beautiful in design and finish, and a **money maker** for the jobber and his customer who handles it.

Made in all desirable signet and locket tops. Bright, Old English, or Roman finish.

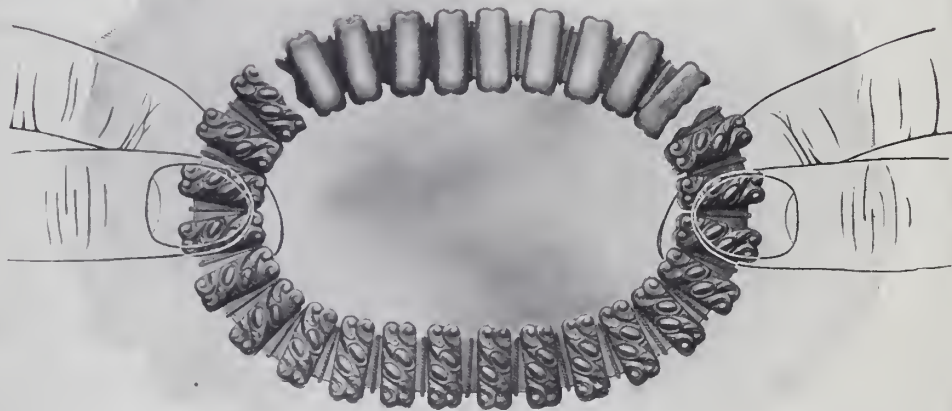

Estate of O. M. DRAPER

North Attleboro, Mass.
Factory

San Francisco, Cal.
503 Chronicle Building

37 Maiden Lane
New York

The "BEST" Safety Fob



Bates & Bacon

ATTLEBORO,
MASS.

High Grade Gold Filled

- Gents Vest
- Dickens
- Safety Fob
- Secret Locket
- Lorgnette
- Eye Glass

CHAINS

The "WINNA" Bracelets
Strongest Secret Joint and Catch on the Market



Bracelets, Locket, Chatelaines

NEW YORK:
9 Maiden Lane

CHICAGO:
103 State Street



Begin the New Year Right—Complete Your Stock with Right Goods

GOLD RINGS

Gold Scarf Pins

Gold Brooches

A Handsome Line of Seamless Wire GOLD FILLED RINGS

All ready for prompt delivery to the Jobber

OSTBY & BARTON CO.
PROVIDENCE, RHODE ISLAND

New York Office
9-13 MAIDEN LANE

Chicago Office
103 STATE STREET



REPORTS from the trade throughout the country indicate the holiday business was generally satisfactory, particularly so in moderate price gold jewelry and watches, which have always been strong features of our stock. Our lines this season will therefore be particularly adapted for the present conditions and demand, and we will more than ever be "SELLERS OF SELLERS." One of our representatives will shortly call on you.

HENRY FREUND & BRO. 71 Nassau Street
NEW YORK

EAGLE AND ELK GOODS
A SPECIALTY

Jewelry, Watches, Diamonds

Our Trade-Mark "The  Rose" stands for quality and excellence and is equal to a Government stamp.



WE show herewith a new style bag—an exceptionally strong, stylish, snappy article.

Our new Spring line is complete—covering the entire range of bags—all shapes, all the different styles of mesh—the largest assortment of frames ever shown. Every piece stamped. W. & D. an absolute guarantee of satisfaction.

Your Jobber has them.

WHITING & DAVIS
PLAINVILLE (Norfolk Co.), MASS.

New York Office, 7 Maiden Lane

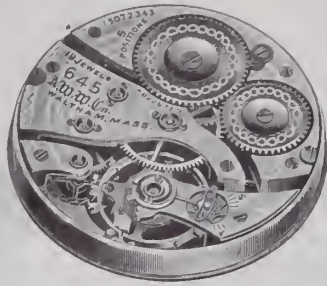

WE CARRY ALL GRADES OF

RAILROAD MOVEMENTS



Send us your orders for ANY goods you may wish, as we carry all kinds of goods used by first-class Jewelers, either in the Watch, Diamond, Gold and Plated Jewelry Line. Watch Materials, etc., etc.

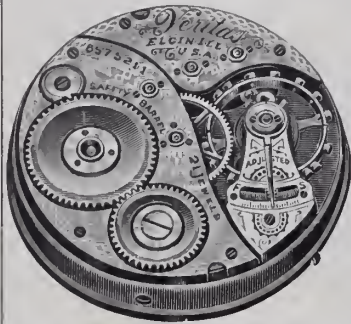

CROSS & BEGUELIN

31 MAIDEN LANE
NEW YORK

Established 1863 Telephone, 480 John



RETURN
OF THE
SASH PINS



A
VOGUE
FORESEEN

ANTICIPATION is a form of enterprise. This house has foreseen the return of the Sash Pins, which have been somewhat over-shadowed by Buckles the past few years—but they are rushing back into favor again. The easy adjustability of Sash Pins renders them eminently practicable, and they impart that graceful dip to the waist which modistes love. Besides rich die effects, fine imitation stones adorn new designs.

AMETHYST—TOPAZ—LAPIS LAZULI

D. Lisner & Co. *Creating Importers of* *Jewelry Novelties*
One-Forty Fifth Avenue, cor. 19th St., NEW YORK

The KREMENTZ LINE of SERPENT JEWELRY

IN
NECKLACES
AND
BRACELETS

MOUNTED WITH DIAMONDS, SAPPHIRES,
AMETHYST, TOPAZ, TURQUOISE MATRIX, ETC.
Bracelets Are Supplied With Solid 14-Kt. Gold Springs

NECKCHAINS of Any Length Desired



Bracelet, 2098.
Neckchain, 2140.

Necklace, 2122.

Bracelet, 2118.
Neckchain, 2129.

KREMENTZ & CO.

Manufacturers of

Fine Gold and Enamel Diamond Jewelry in 14-Kt. Only

MADE EXCLUSIVELY FOR FINE RETAIL JEWELRY TRADE

BRANCH
San Francisco Office
722 Shreve Bldg.

Factory and Main Office
NEWARK, N. J.

BRANCH
New York Office
1 Maiden Lane

A HUNDRED STYLES IN STUDS

TRADE



MARK

A CENTURY of Studs, a round hundred styles; this cycle of showings affords exceptional range for selection. Studs for dress occasions, studs for ordinary wear, studs for mourning, studs for all occasions. There is no doing things by halves. So complete a line solves all Stud problems.

TRADE



MARK

DURAND & CO.

49-51 FRANKLIN STREET
NEWARK, N. J.



OSMUN-PARKER MFG. CO.

MAKERS OF

Fine Pearl and Diamond Goods

338 Mulberry Street
NEWARK, N. J.

ENOS RICHARDSON & Co.

MANUFACTURERS OF

14-K GOLD JEWELRY

TRADE MARK.



- | | |
|-----------------|------------|
| HANDY PINS | TIE CLASPS |
| SAFETY PINS | VEIL PINS |
| BROOCHES | HAT PINS |
| FLAT LINKS | SCARF PINS |
| DUMB-BELL LINKS | BARRETTES |
| FOBS | BELT PINS |

10-K AND 14-K NECK CHAINS AND GUARD CHAINS

PLAIN AND JEWELLED LORGNETTE CHAINS

23 MAIDEN LANE, NEW YORK



The R. S. Cigar Cutter

In Sterling Silver, Plain and Engraved; and 14 k. Gold, Plain and Engraved, also Set with Diamonds.

A Novelty

Unlike all other cigar cutters, this one lies flat in the pocket—does not get out of order.

A Good Article



We Push It

Our advertising makes the customer want it; his friend sees it and he wants it. An endless chain of customers.

A Good Seller



Trade supplied by

Enos Richardson & Co.

23 Maiden Lane, New York.

G. R. HOWE
W. T. CARTER
W. T. GOUGH

ESTABLISHED 1841 BY A. CARTER

F. R. HORTON
F. W. STANBROUGH
H. L. FARROW

CARTER, HOWE & CO.

MANUFACTURERS OF

GOLD JEWELRY



Bags and Purses in Gold and Silver

9-11-13 Maiden Lane, New York

Factory, Newark, New Jersey

I. N. LEVINSON
President

ESTABLISHED 1865

H. S. MORRIS
Sec. & Treas.

S. COTTLE COMPANY

Makers of High-Grade Gold and Silver Novelties



Mesh Bags
Card Cases
Purses

Buckles
Vanity Cases
Chatelaines



Our new line for Spring is now ready for inspection. Many new and artistic designs are shown. We wish to thank our many patrons for their past favors and hope for a continuance in the future.

PARIS
28 Rue D'Hauteville

31 EAST 17th STREET, NEW YORK

FRANKFURT a/M.
Hanse-Haus, 9 Stiffstrasse

GARREAUD & GRISER

68 & 70 Nassau St., New York
LAPIDARIES. PRECIOUS STONES
GEMS in Unique Cuttings

UNIQUE GEMS
SEMI-PRECIOUS CEYLON, URAL and NATIVE
GEMS My Specialty
Prices the Lowest. Sample Papers sent on Request
to Reliable Jewelers and Manufacturers.

Louis J. Deacon, Atlantic City, N. J.

SCARF PINS



Jade, Coral, Opal Matrix, Star-Sapphires, and other stones, in 14k. plain edge.

35 Maiden Lane,
New York.

Geo. O. Street & Sons.

Here Are the Reasons



CONSIDER THESE
ADVANTAGES

*Excellence in Finish
and Appearance*

Unquestioned Quality

A 10 K. line as well made as any
14 K. line on the market.

You will see at once that you
need the KELLER LINE for 1908.

BUTTONS A SPECIALTY

KELLER JEWELRY MFG. CO.

MANUFACTURERS OF FINE GOLD JEWELRY

Brooches, Link Buttons, Locketts, Scarf Pins, Combs, Fobs,
Tie Clasps, Charms, Lorgnette Chains, Neck Chains.

64 Nassau St., NEW YORK

Factory, 251 N. J. R. R. Avenue

NEWARK, N. J.

BUY GOODS WITH A TRADE-MARK

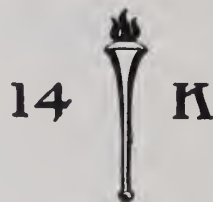

BANGLES
BROOCHES
BANGLE BRACELETS

HANDY PINS
TIE HOLDERS
VEIL PINS

A General Line of Fine Jewelry

BIPPART, GRISCOM & OSBORN

OFFICE AND FACTORY
Newark, N. J.

NEW YORK SALESROOM
1 West 34th St.

THE BEST

SOLID GOLD CHAINS

THE CHEAPEST

They stand the
test of time and
have done so for
56 years.

Supreme in
**QUALITY
DESIGN
FINISH
WORKMANSHIP**



We Sell Direct. We
Have No Salesmen.
Eliminating all
unnecessary ex-
penses in making
and selling ena-
bles us to sell at
the lowest pos-
sible price. Send
for catalogue.

Trade  Mark

1850 1907

ALOIS KOHN & CO.

16-18 Maiden Lane, New York
Makers of **Gold Chains** of every kind

Don't Worry About the Scarcity of Money

If you need any send us your surplus
stock of Diamonds, Watches, Jewelry,
Old Gold and Silver, and get our certified
check by return mail. If amount is not
satisfactory goods will be returned in same
condition as received. Strictly confidential.
Correspond or call. Telephone, 5202 John.

New York Jewelry Purchasing Co.
106 Fulton Street, New York

INEXPENSIVE JEWELRY



TO meet a present and ever increasing demand for artistic creations of medium price, we have originated an entire line of inexpensive jewelry, having devoted the same care and attention to its manufacture that our well established line of highest quality has always been given.

The identical designs have been adopted; the mountings are all of 14-kt. gold, set with precious and semi-precious stones of medium and low price, that cannot fail to attract attention and readily be disposed of.

- | | |
|-------------------------------|---------------------|
| Locketts | Cuff Buttons |
| Scarf Pins | Brooch Pins |
| Bracelets | Festoon Necklaces |
| Art La Vallieres | Baroque Specialties |
| Amethyst and Matrix Novelties | |



Representative Jewelers are invited to send for a selection.

COOPER & FORMAN

Makers of Diamond Jewelry

OFFICE AND FACTORY:

3 MAIDEN LANE, NEW YORK

Links for Summer Shirts

APPROPRIATENESS is a virtue. There are Links that seem to belong to the Summer shirt. These Gem Links are an example. They strike the true note of color. Stones:

AMETHYST, TOPAZ, GARNET
CHINESE JADE, NEW ZEALAND JADE

Scarf Pins to match emphasize the pleasing harmony. Good selling lines appealing to gentlemen of taste.

... Scarf Pins to Match ...

Day, Clark & Co.

MAKERS OF 14-KT JEWELRY
23 MAIDEN LANE
NEW YORK

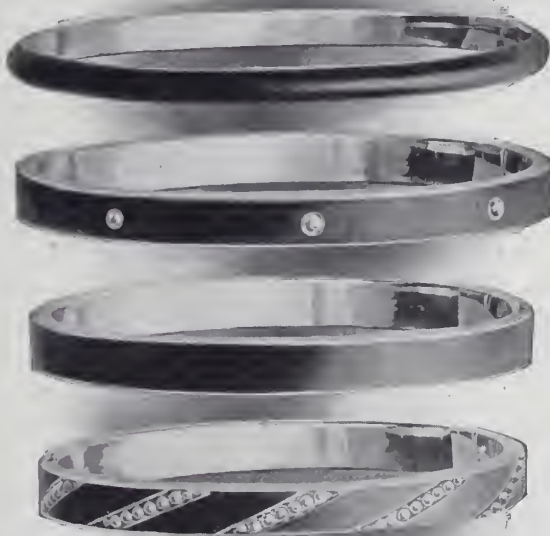

Mourning Goods
of all kinds

- Bracelets
Brooches
Scarf Pins
Buttons
Studs
Necklaces
Everything in Black



A. J. HEDGES & CO.

Makers of 14K. Jewelry

14 John St., NEW YORK

SNOW & WESTCOTT
 21 MAIDEN LANE, NEW YORK

TRADE  MARK

ESTABLISHED 1834

JAMES P. SNOW CHAS. E. WESTCOTT

MAKERS OF FINE GOLD
**scarf pins, links,
 brooches, handy-
 pins, chatelaines,
 fobs, etc., MADE IN
 14 KARAT EXCLUSIVELY**



SEED-PEARL NECKLACES IN ALL SIZES.

OSMERS-DOUGHERTY CO.
 MANUFACTURING JEWELERS
 291-293 SEVENTH AVE., NEW YORK
 Bet. 26th and 27th Sts. Telephone, 913 Madison.

DEALERS IN **BAROQUES, PEARLS and FANCY STONES**  TRADE MARK **DESIGNING AND SPECIAL ORDER WORK**

TURQUOISE
Matrix - Turquoise
 Best the World Produces

WE ARE prepared to furnish to the trade Matrix-Turquoise in all shapes and sizes.

Exquisite Color and Markings

We cut Turquoise to order

Mines at Mojave County, Arizona

THE ARIZONA
TURQUOISE MINES CO., Inc.
 Cutting Works and Sales Office
 171 Broadway, New York

SEND FOR CATALOG

Telephone 5728 Cortlandt

"THE BRACELET HOUSE"

GOLD BRACELETS of every kind For WOMAN, MISS OR BABY

KENT & WOODLAND
 16 John Street, New York

Factory: Newark, N. J. San Francisco: Julius A. Young

1908 The Year for Coral

Largest Importers of Coral Cameos, Pears, Beads, Etc., Shell Cameos.

Inquiries Solicited from Manufacturers of Jewelry.

Jade, Amazonite, Lapis, Coral, Topaz, Amethyst, Aventurine, Our Specialty.

VAN DUSEN & STOKES CO.

1123 Chestnut Street

PHILADELPHIA, PA.



FANS
 AND FRENCH
 JEWELRY NOVELTIES

THE latest European Novelty in all grades of

FANS

Lace, Painted and Spangled effects, mounted on bone, ebony and mother-of-pearl sticks.

Our goods are made especially for the jewelry trade.

Send for selection, mentioning price.

LEWY & COHEN

Importers of Fans, Jewelry Novelty, Festoons, Buckles, Chains, Necklaces, Collars, and Jet Goods, Etc.
 530 Broadway, New York

The "Bryant" Rings.

WE have made the **Bryant Rings** for 50 years, and know how to make first class goods. The stone setting—which every retailer knows is a very important part of the work—we give special attention to. The **Bryant Rings** will help your reputation as a first class Jeweler.



M. B. BRYANT & Co.,

No. 7 MAIDEN LANE,
NEW YORK.

New Cigar Cutter

LOOKS AND WORKS LIKE A CHARM

This is the only practical cigar cutter that is a piece of jewelry for fob or chain. Can be set with diamonds and will admit of full size monogram engraving.

Patented and manufactured in 14K Gold by

Kollmar, Rauch & Co.
306 Market Street, Newark, N. J.

Sleeve Buttons
Fobs
Barrettes



Brooches
Scarf Pins
Handy Pins



The Bowden Rings

ARE COMPLETE IN VARIETY, CORRECT IN QUALITY AND PERFECT IN FINISH. WE MAKE EVERY VARIETY OF FINGER RINGS.

J. B. BOWDEN & CO.,

1 Maiden Lane.

NEW YORK.

MIRROR PLATEAUX



JOHN E. ROHRBECK, Manufacturer
40 Fulton Street, NEW YORK
J. T. JACKSON, 839 Market St., Phila., Pa.
DORRANCE-BATTIN CO., Chronicle Bldg., San Francisco, Cal.
P. HANLEY, 597 Washington St., Boston, Mass.
YARWOOD & HERBERT, 55 Park Place, City

Send for the Latest Styles in MONOGRAMS AND INITIALS

as manufactured by
THOMAS J. DUNN CO.

101 Chambers St., New York
Makers of exclusive styles in
MONOGRAM FOBS

in Gold, Sterling and Rolled Gold Plate.
Our 1908 Ladies' Belt Buckles are most original and artistic.
Specialties in the Monogram and Initial line.

Send for Illustrated Sheets.



"HOLD-ON" CLUTCH



FOR SCARF PINS AND BROOCHES

14K. GOLD PLATE
SUPERIOR TO ALL OTHERS

PRICE 50 CENTS

————— **ADVANTAGES:** —————

1. *It Holds*—The harder you pull, the tighter it holds.
2. *To Release*—Raise the clutch and pull the ball.
3. *All One Piece*—No parts to lose.

HOLD-ON CLUTCH CO. 33 GOLD STREET NEW YORK

Pat. May 20, '02
To Release
Pull the Ball

Pat. May 20, '02
Attached
to Scarf Pin

Insure Your Life

L. A. Miller

Special Agent of the

Equitable Life Assurance Society

will show to any who may be interested Sample Annual dividend policies on the

LIFE, LIMITED PAYMENT, ENDOWMENT, and TERM PLAN

ADDRESS

L. A. Miller

Special Agent

180 Broadway, N. Y.

One of Our Business Builders



A full and complete line of Hair Ornaments, combining originality, price and quality.

Schultz & Co., Inc.

Makers of Business Builders

which means an up-to-date, original line of strictly 10 Karat Gold Jewelry of all kinds.

Factory and Office 91 Oliver St. Newark, N. J.	 Trade Mark	New York Salesroom 12-14 John St. N. Y. City
--	--	--

This Company will change its name July 1st, 1908, to

LAYMAN & STRAUS CO.

Percy M. Layman Sydney C. Straus



HERMAN KOHLBUSCH, Sr.,

ESTABLISHED 1859.

Manufacturer of Fine Balances and Weights
for every purpose where accuracy is required.

Office and Salesroom, 194 BROADWAY, NEW YORK.

Send for Price List. Tel. 370, Cortlandt.

Monograms

INITIALS AND FOBS

Our Specialties

Write for Catalogue, Prices and Discounts.



CHICAGO ART METAL WORKS
63 Lake Street
CHICAGO, ILL.

CHARLES M. PRIOR, Designer

We have ready many new designs. Call or write. Etching is more popular than ever and we do it in the finest style.

'Phone 1639 Gramercy 24-26 East 21st St., NEW YORK

PATENTS

obtained on inventions and designs. Trade-marks, prints and labels registered.

R. W. BISHOP,
ATTORNEY-AT-LAW,
908 G Street N. W., Washington, D. C.

SPRING TONICS

TONE up your Spring business with some of our INVIGORATORS



14 K., Pearl Set, \$4.50
A Leader in Brooch Values

New Things in Brooches, Links, Scarfs, Fobs, Buckles, Bracelets, Combs, Hat Pins, Veil Pins, Bags, Festoons, Etc.



2 Maiden Lane New York City

THE WASHBURN

SECURITY Automatic Holder for all sizes of scarf-pin wire. Guaranteed.
MAGIC NUT For ear studs, scarf-pins etc.

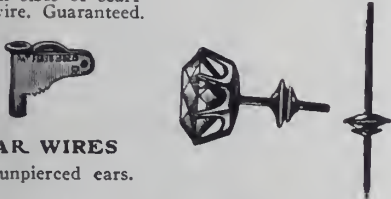

EAR WIRES
for unpierced ears.

SAFETY CATCH
For Brooches, etc.
Can be applied to any work where pin tongues are used.



Open. Closed. Open. Closed.
Descriptive Circular on Application.
Pearl Drilling and Adjusting a specialty.
Special Order Work and Repairing.

C. IRVING WASHBURN, 12-16 John St., N. Y.

HOROLOGICAL DEPARTMENT

BRADLEY POLYTECHNIC INSTITUTE
Formerly Parsons Horological Institute
PEORIA, ILLINOIS
LARGEST and BEST WATCH SCHOOL in AMERICA
We teach Watch Work, Jewelry, Engraving, Clock Work, Optics. Tuition reasonable. Board and rooms near school at moderate rates
Send for Catalog of Information



A MILLION RINGS ARE NOW worn that are loose on the finger and need Wells Perfect Ring Adjusters to hold them in place. Why not fit these and make a good profit and new customers.

Ask your Jobber for them
Sold in 1 doz. assorted sizes in packages as follows: 10 K. Gold, \$3.75; Gold Filled, \$2.00; Metal, 85 cents.

CHESTER H. WELLS, Jeweler, Meshoppen, Pa.

"If It Is Chopard's Idea, It's Ideal"

A
L
L
Q
U
A
L
I
T
I
E
S

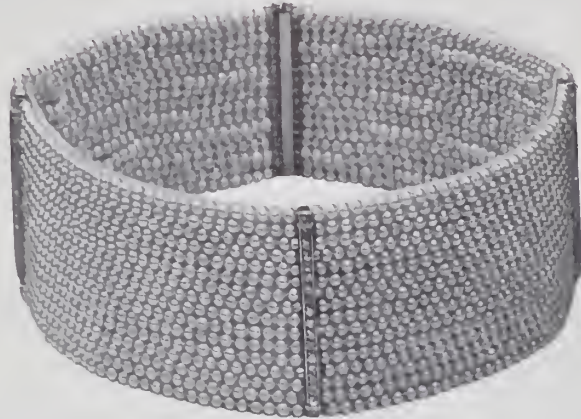

A
L
L
S
I
Z
E
S

OUR PEARLS resemble others only in name. Here the comparison stops, for in Quality, Lustre and Durability they defy competition.
COLLARS, NECKLACES, FAN CHAINS in stock.

Remember our Special Department created for you. For Restringing and Mounting Pearls and Pearl Collars AT MODERATE RATES.

CHOPARD FRÈRES

Factory, 35 Rue des Trois Bornes, PARIS, FRANCE

49 Maiden Lane, NEW YORK, N. Y.

The Comb House

Q We beg to call your attention to our fine line of new, Exclusive and Artistic Combs, both plain and mounted in Genuine and Imitation Tortoise Shell. **Q** We manufacture Combs exclusively in Genuine and Imitation Shell, both plain and mounted in 14kt., 10kt. Sterling and Gold Filled

SELECTION PACKAGES SENT TO RELIABLE JEWELERS

Wagner Comb Manufacturing Company

41 Union Square HARTFORD BUILDING New York

MANUFACTURER OF HIGH-GRADE DIAMOND MOUNTINGS



Prompt Attention
Given to Special
Order Work :: ::

Estimates and
Designs Submitted :: :: :: ::

Patented October 24, 1905.

DIAMONDS RECUT AND REPAIRED

JULIUS WODISKA, 40 John St., New York

"VERIBEST" LOCKETS



"Good As Gold"

BE RECEPTIVE TO NEW IDEAS

"Heaven pity the man who won't be shown." If all of the good ideas that have been pigeon-holed and waste-basketed had been considered and utilized, the world would be richer and wiser.

LOOK FOR OUR LINE OF
LEDERERMAK LOCKETS

A LIFETIME SATISFACTION GUARANTEED

Exclusively Sold by **VERIBEST** Jobbers Everywhere

Manufactured by

Established 1870

S. & B. L. ★ CO.

Famous 1908

9-11-13 Maiden Lane, New York City 100 Stewart St., Providence, R. I. 131 Wabash Ave., Chicago, Ill.

Roller Chain

OUR SPECIALTY

Do not forget that we still continue to show the best line of these goods on the market, in Fobs, Bracelets and Neck Chains. These wear longer, give better satisfaction than any metal fob made, and our designs are up-to-date. Also our line of chains of all kinds find a ready market among the best trade, both in 1-10 and a medium wearing grade.

We also make a nice line of Brooches, Hat-pins, Scarfpins, Barrettes, etc., that should demand your attention.

Ask your jobber, and if unable to obtain them from him, advise us who he is, and we will make arrangements for you to get them.

B. S. FREEMAN CO.

ATTLEBORO FALLS, MASS.

Chicago Office, J. T. Edwards, 103 State St., Chicago, Ill.

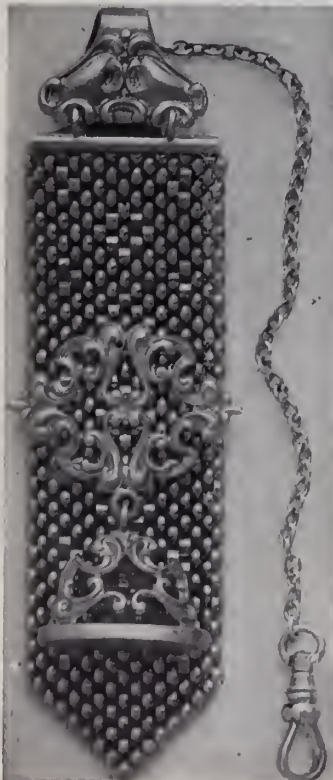

P & B FOBS

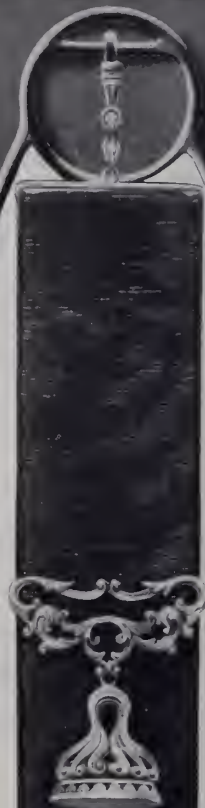

ALL STYLES AND PRICES
BOTH RIBBON AND ALL GOLD

WE ARE THE LARGEST ENGLISH MAKERS OF OUR JEWELRY

ASK YOUR JOBBER FOR THE P. & B. LINES OF

Cuff Buttons Crosses Tie Clasps

Brooches Fobs Baby Pins

Beadnecks Locketts Bracelets

NEW YORK OFFICE: 65 NASSAU ST.

**POTTER &
BUFFINTON CO.**

PROVIDENCE, R. I.

Perennially Popular

THE best evidence of the popularity of our various lines is the increasing demand for them and our consequent growth. Our jewelry is unexcelled in every quality that contributes to serviceability and appearance. The designs are artistic enough to court that investigation which results in sales.



Ask to see our line of

**CHAINS
CHAIN PENDANTS
CROSSES
AND BRACELETS**

The

**Kenilworth
Bracelet**

particularly, the strongest on the market.



**DORAN,
BAGNALL & CO.**

North Attleboro, Mass.

OFFICES

New York: 194 Broadway
Chicago: 42 E. Madison St.
San Francisco: 91 Drumm St.

10K. GOLD BRACELETS

New and Original
—Designs in—

**BANGLE, JOINT
AND
CATCH SIZES**

Scarf Pins, Ladies' Rings
Earrings and Handy Pins

in a great variety
of designs

TRADE MARK

**THE
Edwin Lowe & Co., Inc.**

F.W. BODWELL, Pres. & Gen. Mgr.

116 Chestnut St., PROVIDENCE, R. I.

New York Representative: Western Representative:
E. T. Wilson, 180 Bway. S. H. Brower

THE CROWN PATENT SAFETY GUARD



For Scarf Pins Studs and Lace Pins. The most practical and only adjustable one invented. Price, \$1.50 per doz. For sale by all wholesale jewelers and material houses. Sample by mail, 25c.; in 10k. gold, \$1.00; 14k., \$1.25. M. CROHN, Maker and Inventor, 48 and 60 Maiden Lane, N. Y.



While your business is somewhat dull you will find it to your advantage to look up the local order for

CLASS PINS

Write us for Catalogue J 30, and Samples

THE CHAS. M. ROBBINS CO.

MANUFACTURING JEWELERS AND ENAMELERS
ATTLEBORO, MASSACHUSETTS



Orders Prove Our Goods Sell

We make for the Jobbing Trade the following lines of Solid Gold Jewelry:

Rings, Scarf Pins, Studs, Brooches,
Charms, Baby Pins, Handy Pins,
Chain Sets, Link Buttons, Hair
Barrettes, Crosses, Ear Screws,
Pierceless Drops, Cameos in all
styles, etc.

Insist upon seeing the designs of Gold Jewelry made by the

E. L. Spencer Co.

95 Chestnut Street, PROVIDENCE, R. I.

New York Office, 9-11-13 Maiden Lane

(SAMPLES ONLY)

LOCKETS ONLY

S. F. Myers & Co.

WHOLESALE JEWELERS
47-49 Maiden Lane
New York

Good value is the best advertisement ever issued. We preach it and practice it.

For the trade only—our new, big catalogue, with 100,000 items, sent free.

Registered



U. S. Pat. Office



Pat. Applied for
NUMBER
8482

Latest Design Appropriate for Easter

WIGHTMAN & HOUGH CO.

NEW YORK OFFICE
3 Maiden Lane

Main Office and Factory } 7 Beverly St.
PROVIDENCE, R. I.

EVERYTHING IN LOCKETS AND CHAINS.



THE BASSETT JEWELRY CO.,
PROVIDENCE, R. I.

Roger Williams Silver Co.,

PROVIDENCE, R. I.

Sterling Only.

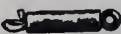
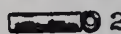
RICH DESIGNS :: :: :: Photos. on Application.

-  1. 1. Snap complete.
-  2. 2. Outside of snap.
-  3. 3. Inside of snap.

The E. P. H. Patent NON-PULL-OUT Neck Chain Snap

is a patented snap that insures the wearer against loss of

CHAIN or CHARM
for it positively will not pull out

Made in 10 and 14 Karat Gold and
In Gold Filled.

Can be had of the following Wholesale
Selling Agents:

- Messrs. W. Green & Co.,
81 Nassau St., New York
- M. Sickles & Sons, Philadelphia
 - E. A. Cowan & Co., Boston
 - E. & J. Swigart, Cincinnati
 - Swarthill & Co., Chicago
 - Nordman Brothers, San Francisco
 - Leonard Krower, New Orleans
 - A. Walker Co., Providence, R. I.
 - Bauman-Massa Jewelry Co., St. Louis
 - H. S. Meiskey Co., Lancaster, Pa.
 - The Edw. Lehman Jewelry Co., Denver, Col.

PRICES.

- 14 Karat—Small, \$7 per doz. net
- Large, \$7.50 per doz. net
- 10 Karat—Small, \$6 per doz. net
- Large, \$6.50 per doz. net
- Gold Filled—Small, \$2 per doz. net
- Large, \$2.25 per doz. net

GEMS AND PRECIOUS STONES

Cloth, Postpaid, \$1.00.

Published by The Jeweler's
Circular Publishing Co.

11 JOHN STREET

NEW YORK



Women of fashion at present are wearing ornaments for the hair more than ever. We anticipated such a demand for these goods and have on hand a large assortment of Rhinestone, Coral and Jet

BARRETTES

from which to select. We also have a magnificent line of Coral Hat Pins, embodying many catchy designs, exclusive carvings and filigree effects, ranging in price from \$4.00 to \$15.00 per dozen.

SELECTION PACKAGES SENT UPON REQUEST

M. GUGENHEIM, Importer of

Brooches, Festoon Chains, Combs, Hat Pins, Collars, Jet Goods, Mesh Bags, in German Silver, Gilt Metal and Sterling

NEW YORK OFFICE: 33 Union Square, Decker Building

PARIS: 32 Faubourg Poissoniere

An Indispensable Book

for Manufacturers, Jobbers and Retailers alike is

TRADE-MARKS

of the Jewelry and Kindred Trades

Price, \$3.00

The Jewelers' Circular Pub. Co.
11 John St., cor. Broadway, New York

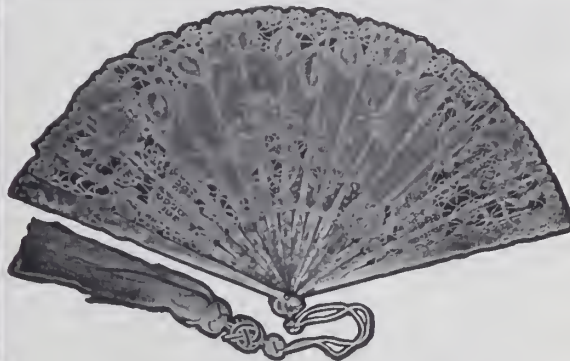

My Stock

of exquisite and unusual effects in FANS is, as usual, the most complete in this country.

Louis Steiner

FANS And Novelties for the Jewelry Trade

520 and 522 Broadway
New York



CAMEOS

Stone, Shell, Coral and Lava.
Rolled Gold Plate Mountings

SELECTIONS SENT TO
RELIABLE JOBBERS

Maintien Brothers & Elliot
North Attleboro, Mass.

Veil, Cuff and Baby Pins

An immense line. Many new designs—supplementing our staple patterns—all of acknowledged beauty, and easily sold.

Cameos A revival of an old-style decoration too good to remain in oblivion.
Shell Coral and others, mounted as Brooches, Stick Pins, etc.

Swastika Buckles Bracelets Buttons
Charms Brooches Barrettes
Combs, Hat Pins, Scarf Pins, Leather Trimmings

MILLER, FULLER & WHITING CO.

Manufacturing Jewelers
New York Office, 9-11 Maiden Lane NORTH ATTLEBORO, MASS.
WE SELL TO THE JOBBING TRADE ONLY





MIDDLETOWN SILVER CO.
35 Maiden Lane
New York



Most
Complete
Line
of
Holders
Now
on the
Market

Write for
Catalogue and
Prices

MANAGER AND SALES AGENT
New York Office for

Middletown Silver Co.
Corning Cut Glass Co.
O. F. Eggington Co. (Cut Glass)
Also Rogers Silver Plated Ware

“SECURON”

“Geraldine Farrar” Gold Medal Bracelets



GUARANTEE Pr. St. Co. MARK INSIDE
WITH SLIDING PATENTED WIRE PROTECTOR

PROVIDENCE STOCK CO.

9-11-13 Maiden Lane
NEW YORK CITY

100 Stewart Street
PROVIDENCE, R. I.

131 Wabash Avenue
CHICAGO, ILL.

DEMAND
SECURON
GUARD
HINGE
BRACELETS
FROM
JOBBER

Pierceless Ear Screws

We are making a complete
line of these popular goods.
Samples upon request.

Also a new line of

Brooches
Scarf Pins
Baby Pins
Links
Studs
Crosses
Ear Rings
Rings
Neck Chains

We have manufactured Gold
jewelry for over fifty years
and our goods have stood
the test of time.

DON'T NEGLECT TO
SEE OUR LINE.

Wm. C. Greene
Co.

Established 1849 Incorporated 1906

MANUFACTURERS OF
GOLD JEWELRY

101 Sabin Street,

Providence, R.I.



It's the Little Things that count.

The dainty little things that appeal at once to
the casual observer. If it's useful, as well as or-
namental, so much the better. Here is a LITTLE
THING, so very useful and so pretty in design and
finish, that you have but to show one to make a
sale, and it yields a BIG PROFIT. It is called

The Automatic Eye-Glass Holder

Can be used as well for a Pencil Holder. It is made
in Enamel, Gold, Silver and Rolled Plate, in a variety
of artistic designs. We fully guarantee every Holder.
We mean it, and will replace any Holder that fails to
satisfy. Samples sent upon request. Send for catalogue.

Est.
1832. **Ketcham & McDougall**, Manufacturers,
37-39 MAIDEN LANE, NEW YORK.
ALSO MAKERS OF THE LEADING LINE OF THIMBLES.



Practical Course in
Adjusting

Published Price, \$2.50
Special Reduced Price, \$1.50, Postpaid

All Jobbers, or
Jewelers' Circular Publishing Co.

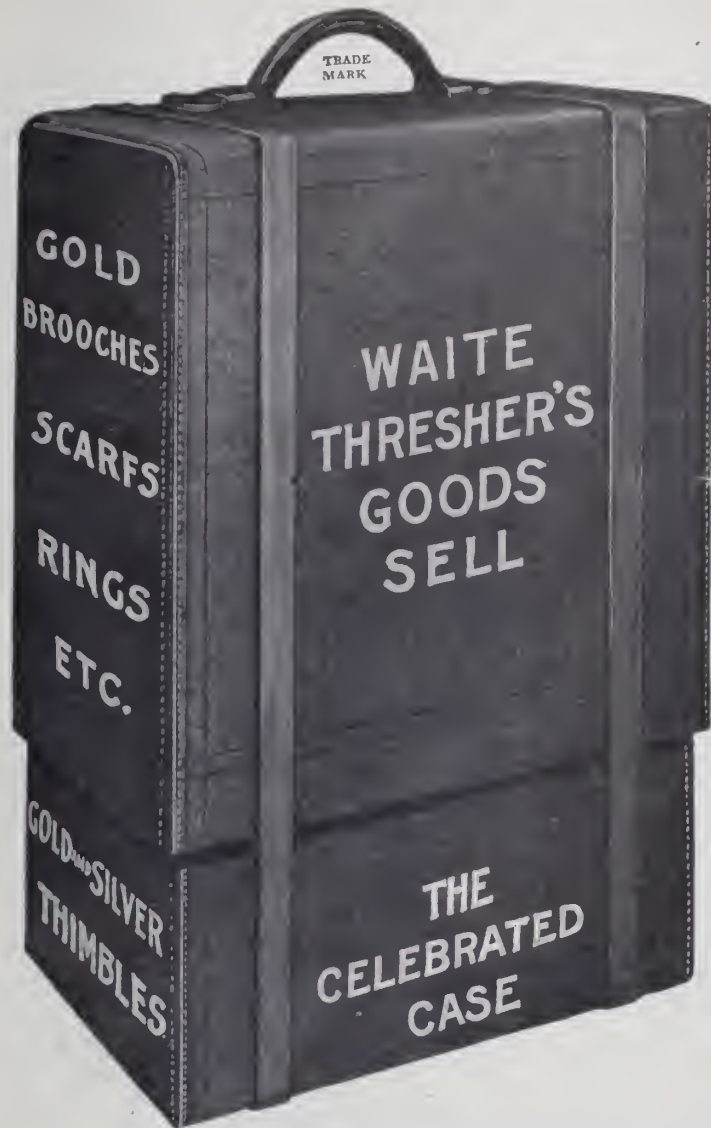

INFORMATION

The right kind of information—the kind that will help you in your daily business work—information that will save you many a dollar is found in our Yearly

GREAT

American Jewelry Catalogue

ASK FOR IT

THE OSKAMP NOLTING CO.

Mammoth Wholesale Jewelers

413-415-417 Elm Street CINCINNATI, OHIO

The "SECURITY" Necklace Clasp

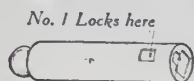

No. 2 Locks here

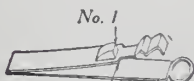

No. 2 Patent applied for.



No. 1



No. 1B



No. 2

HEAR IT SNAP
Absolutely Secure and Simple. Cannot Pull Out
LOCKS IN TWO PLACES

Making it Doubly Secure
The Only Perfect Clasp

Ask Your Jobber or Write.

PRICES TO THE TRADE:

No. 1.	10-Karat,	- - -	\$6.00 doz.
" 1-B.	10 "	- - -	7.00 "
" 1.	14 "	- - -	7.00 "
" 1-B.	14 "	- - -	9.00 "
" 2.	10 "	- - -	9.00 "
" 1.	Platinum,	- - -	18.00 "
" 1.	Gold Filled,	- - -	2.00 "
" 1-B.	" "	- - -	2.25 "
" 2	" "	- - -	2.50 "
" 1.	Sterling Silver,	- - -	2.00 "

The Hoffman Novelty Co.,

"CLINCH"



No. 2
50 cts.
35 cts.



No. 1, 25c.

Safety Catch for Scarf Pins

Does not mar the pin. Nothing to get out of order. Simple and neat.

One turn to the right grips like a vise.

..FITS ANY SIZE PIN..

Patent applied for.

PRICES TO THE TRADE

No. 1	Gold Plated	\$1.50 doz.
No. 2	Roman Gold	2.00 doz.
No. 2	14k G'ld Pl'te	2.25 doz.

Makers, 79-83 No. Pearl St., ALBANY, N. Y.

The Best Selling "Thread" Pattern in the Trade



The SMITH "PILGRIM"

There never has been a more artistic and lasting design than the Smith "Pilgrim." It is characterized by simple elegance, refinement and dignity of design, and grateful absence of over-ornamentation. The Smith "Pilgrim" pattern will remain permanently in demand. Include "Pilgrim" in your stock. It is without question the best selling "thread" pattern in the trade to-day. Made in all the fancy pieces.

FRANK W. SMITH CO. MANUFACTURERS OF STERLING SILVERWARE Gardner, Mass.



ENGELSMAN'S Patented "GEM" COMBINATION DISPLAY RINGS and ADJUSTABLE STONE HOLDERS meet a long-felt want

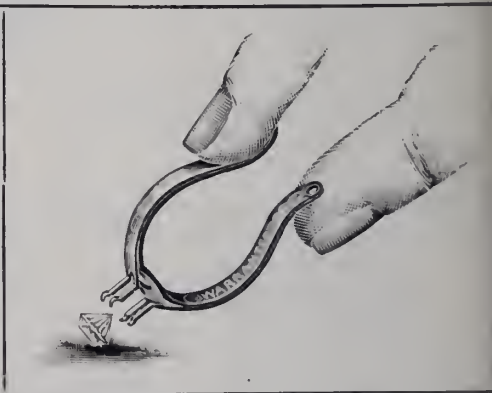
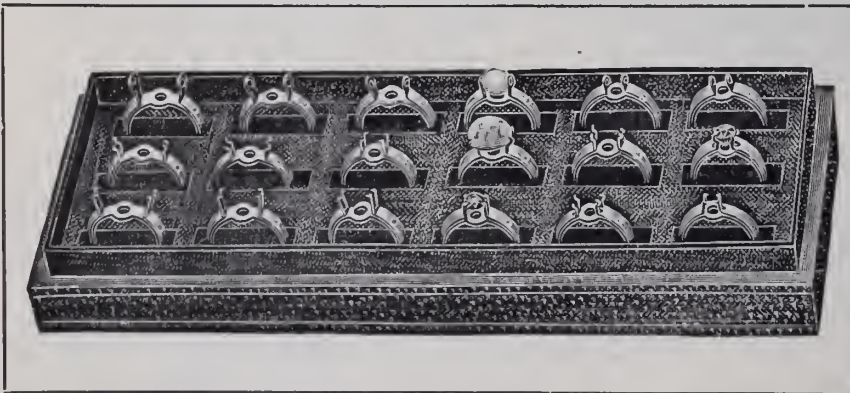

- ☞ As indicated in the accompanying illustration, they are adjustable to any size finger, and hold from the *smallest* to the *largest* size stones, of all kinds and shapes which are generally used, including PEARLS or similar circular-shaped stones.
- ☞ Any of the sets consists of three (3) different specially-formed prongs or settings, to permit of the various kinds and shaped stones being temporarily set up, effectively and advantageously shown.
- ☞ Innumerable unmounted stones, which heretofore could not be permanently exhibited, can now be attractively displayed in the jeweler's show window with no additional investment, which otherwise would be necessarily incurred by buying a larger stock of mounted goods.

Sets of Display Rings	Price per set
18 (full set) in box . . .	\$12.00
12 " " " . . .	8.00
9 " " " . . .	6.25
6 " " " . . .	4.50

- ☞ Every prospective buyer can now leisurely and advantageously examine any stone or combination of stones without the fear of dropping or damaging any stone. In other words, the use of the tweezers can be eliminated.
- ☞ DEALERS of loose stones will see the utility of the "GEM" stone holder, particularly needful in their business. SPECIAL and SEPARATED stones may be set up temporarily in these stone holders and placed in diamond papers without, however, necessitating the handling or showing of these respective stones by the customary use of the tweezers, thus *reducing* the risk of damaging a stone, oftentimes at a great loss and many times an irretrievable damage, which frequently occurs by a stone "jumping out" from the tweezers.

FOR SALE AT ALL JOBBERS IN THE UNITED STATES AND CANADA

HAMMEL, RIGLANDER & CO. 47-49 MAIDEN LANE NEW YORK CITY



The Gillette Safety Razor Set consists of a triple silver-plated holder and twelve double edged, thin, flexible, wafer-like blades (24 keen edges), packed in a velvet lined leather case. Price, \$5.00. Also made in Combination Sets in a variety of styles with toilet accessories retailing from \$6.50 to \$50.00 each.

Would You Have the Coming Year Bring You Increased Patronage, Profit and Prosperity?

Do you realize that nearly every hour in the day some man is converted to the easier, quicker and more economical way of shaving himself with the

Gillette Safety Razor?

Our persistent and vigorous advertising in the leading publications of this country discloses — *and will continue to disclose* — beyond all question of doubt, the superiority of the "Gillette." It advocates the advantages of self-shaving and guides the man to your store with a five dollar bill to exchange for the best shaving device in this world.

You can readily see the wisdom of having the "Gillette" ready when he calls. The Standard Gillette Set retails at \$5.00 everywhere. Combination Sets from \$6.50 to \$50.00. Keep a good supply in stock. Write to-day for valuable selling information and prices.

GILLETTE SALES CO., 904 Times Bldg., New York City



The Kind that Sell



The goods that make the most profitable sellers are the ones whose quality you can depend upon. Our "F. & B." trade-mark is a symbol of the best, combined with attractiveness. We have some of the most beautiful designs in Locketts and Charms, Brooches and Bracelets, Hat, Scarf and Veil-Pins, as well as Links and Festoon Necks. Remember, too, our fine line of Sterling Silver, consisting of many new articles in Toilet and Manicure Goods, Candle Holders, Frames and Novelties.

Illustrations Full Size



Neck Chain 281—Antique Finish

Baroque Pearl Drops. Jade Stones



Fob Chain 1583
Rose. Signet Charm
Stones set as ordered
1603—Old English



Fob Chain
1586—Rose. Signet Charm
1604—O.E.



Locket 2989—Rose Brilliants
2988— " No Stones



Locket 3009—Rose
3011—Rose Brilliants



Locket 2993—Polished
Engraved



Hat Pin 867
Old English
Hand Chased



Scarf Pin, O. E.
880—Real Amazonite Stone
882—Imitation
Stones set as
ordered



Link 756—Rose
Raised Head



Scarf Pin 883
O.E., Stones set
as ordered



Hat Pin 873
Old English
Hand Chased



Locket 3006—Rose
3008—Rose Brilliants



Locket 3010—Rose
3012—Rose Brilliants

Theodore W. Foster & Bro. Co.

Manufacturing Jewelers and Silversmiths

100 RICHMOND ST., PROVIDENCE, R. I.

NEW YORK: 13 Maiden Lane

CHICAGO: Heyworth Bldg.

CANADA: Kingston, Ontario

Interesting Collection of Pearls from Graves of Mound Builders

COLUMBUS, O., Feb. 5.—Ohio archaeologists have placed on display at the Ohio State University here probably the most interesting collection of fresh water pearls ever shown at any place or any time—there being in all several thousand of them, relics of the long-extinct race known as the "Mound Builders," some of which are of extraordinary interest as giving an idea of the efforts of this strange people to mount precious gems for the purpose of personal adornment.

The collection was found in the famous Harness group of mounds, which are located on the Harness farm, about eight miles south of Chillicothe. The largest of these mounds was explored long ago, but the archaeologists who conducted that work overlooked the most interesting finds which have been made in the rich Ohio field. During a recent re-examination of this mound, workmen uncovered a skeleton, at the side of which was what appeared to be beads of some kind. There were thousands of them, and when they were closely examined they were found to be pearls.

It is presumed they were taken from fresh water clams in what is now the Scioto river, running from north of Columbus to Portsmouth, where it empties into the Ohio. The river is still full of these clams, and occasionally some pearls are found in them, but those obtained these days are small and irregular in shape.

Practically all of the pearls near the skeleton had been carefully perforated in order that they might be strung on a small

larger than a pea or spherical in shape is almost unheard of, the Mound Builders were more successful in their work thousands of years ago. In this one grave, which must have been that of some great chief, great pearls of good shape and half an inch in diameter were found, mounted in virgin copper.

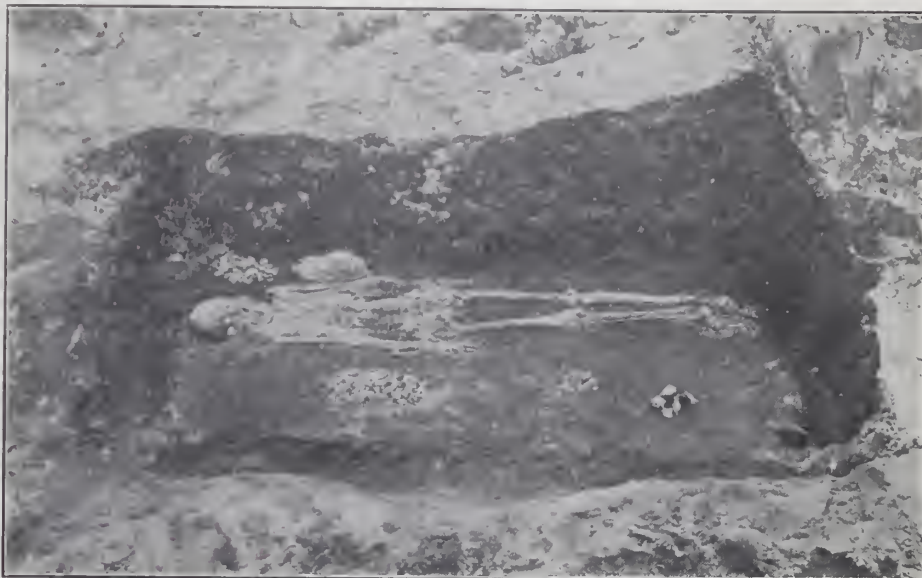

THE GRAVE WHERE THE PEARLS WERE FOUND.

thong. But more remarkable than the find of these were the great individual gems unearthed. While to-day it is rare to find a pearl in the Scioto, and to find one

The settings are, of course, extremely crude, but there are shown some claws, in order to leave as great a portion as possible of the gem uncovered, and the stone was so set in each case that it showed the finer face to the best advantage, proving that the savages knew the art of mounting, using the most precious metal of which they had any knowledge. This was copper, brought from the great fields of Lake Superior, hundreds of miles away from them, and a long, weary journey in those days of slow transportation.

Of the lesser pearls, and even some of the larger ones, many had been flattened on one side, evidently by grinding or rubbing on a flat stone, though what the purpose of this was is not known and cannot even be surmised.

It is estimated that the value of the stones shown in the photograph, if in marketable condition, would be at least \$10,000. As relics they are invaluable, as the collection is without a parallel in America, and probably never will be equaled by future investigations, as the most of the larger mounds have now been thoroughly explored.

The great mound from which the pearls were taken was 160 feet in length, 85 feet in width, and was originally probably 20 feet high. The whole group had evidently



2,100 PEARLS, PART OF STRING TAKEN FROM EDWIN HARNESS MOUND.

No. 4483

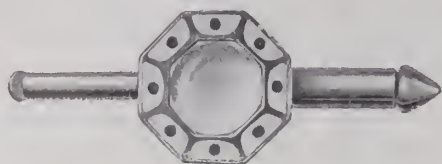

A New Shirt Stud

While we make without contradiction the largest and most varied line of shirt studs in the United States, we are continually increasing it by adding new up-to-date patterns.

The cut above is one from a number of new and original patterns in shirt studs, all having the satisfactory Larter back.

Made in 14K. gold only, with mother-of-pearl center, white enamel and gold border—This combination is not only attractive, but is in absolute good taste for dress occasions.

We also make loose link buttons and Larter vest buttons to match at moderate prices.

LARTER & SONS

21-23 Maiden Lane, New York, N. Y.

TRADE-MARK



REGISTERED IN U. S. PATENT OFFICE

No. 1598



A New Ring

The above illustration is one from a new line of rings for women in both 10K. and 14K. gold, which we are now adding to our stock.

Our rule is not to make the same patterns in both qualities; therefore the above pattern can be had in 14K. gold only, made with cabochon cut opaque stones in the following colors:

Lapis Lazuli	Dark Blue
Dark Chinese Jade	Dark Green
Amazonite	Light Green
Epidote	Olive Green and Red
Turquoise Matrix, Light Blue and Brown	
Coral	Pink

LARTER & SONS

21-23 Maiden Lane, New York, N. Y.

TRADE-MARK



REGISTERED IN U. S. PATENT OFFICE

been hurriedly constructed, as the individual works do not show the great care and precision that mark most of the Mound Builders' structures. Excavations revealed the fact that the site had been enclosed with a row of tree trunks set in the earth, on end, to the depth of about three feet. In this enclosure the dead had been laid on low platforms of earth, and many of the bodies had been cremated before they were finally covered with earth.

As is usual in such cases, the decorations and weapons of the dead were buried

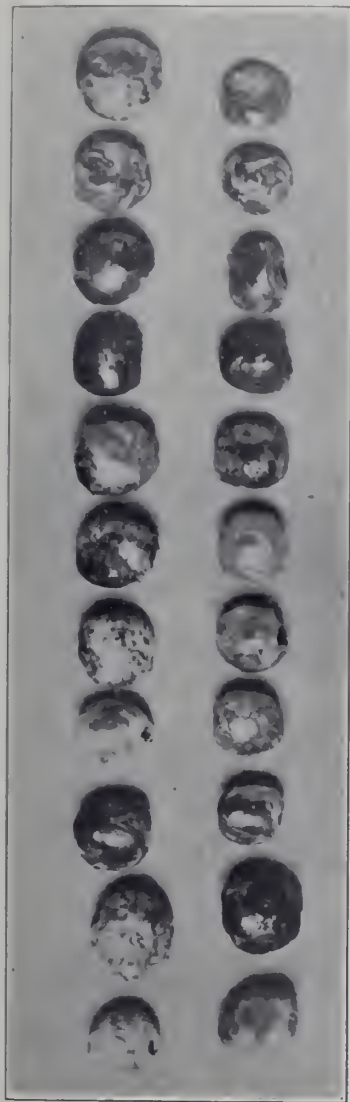

SOME OF THE LARGER PERFORATED PEARLS.

with them, and hundreds of implements and decorations and weapons were recovered in good condition with the skeletons. It was evident that the mound occupied the site of a charnel house, which, when full, was burned and the mound erected over it as a monument to the warriors who lay beneath.

John B. Lang, at one time with the Curtis Calendar Clock Co., Hartford, Conn., and afterwards Mayor of Ithaca, N. Y., died at his home in N. Aurora St., at the latter place, a short time ago, after an illness of several weeks. The deceased was born in Stockport, N. Y., Dec. 22, 1833.

LONDON JEWELRY FASHIONS.

NOVELTIES SEEN BY A SPECIAL CORRESPONDENT.

LONDON, Feb. 4.—Diamonds are by far the most fashionable stones with Englishwomen, and many superb jewels will be worn at the forthcoming court function to be held in early February. At Covent Garden processions of the realm are ablaze with historic jeweled heirlooms, although many family jewels, through the vicissitudes of fortune, have passed into the hands of American *nouveaux riches* and South African parvenues.

The coronet is the most prized possession of an English aristocrat, and is permissible at all full dress functions and in the stalls and opera boxes. No woman who is the fortunate owner of a coronet but who elects to display it as often as possible. The jewels of the Englishwomen are rather ponderous as to shape and conventional as to setting; world-famed gems may be seen on ladies of high degree, wonderful diamonds, rubies and emeralds, the loot from the treasure chests of conquered Indian potentates, and others acquired by the power of money.

The English jeweler runs to conventionalism, little originality of design being seen. He relies on the purity of precious stones rather than artistic setting, the latter being the strong point of French jewelers. Pearls more than ever assert themselves, and are made in light and airy patterns—tiny diamonds and colored gems threaded upon the slenderest of chains, or dangling in almost imperceptible settings in long and glittering pendants or in a golden lattice work with each intersection accentuated with a gem. There are pear and lozenge shaped pendants composed of several magnificent stones or of myriads of tiny ones looking like a river of light.

The Englishwoman is also a worshiper of pearls. Long *sautoirs* of alternating pearls and turquoises are effective. In no country is the turquoise more worn than in England, perhaps because of its becomingness to the fair skin and hair of the average Britisher.

The craze of the moment—an old fashion revived—is the long earring so much worn by the belles of 40 years ago. One notices these earrings everywhere. The goldsmiths have exploited them as affording a new output for their art, the designs being reproductions of early Victorian modes, some of which are charming. There are great baroque pear-shaped pearls dangling from a slender chain of tiny diamonds. Other earrings have rather large stones, from which hang a ruby circlet in the center of which is a pearl. There are oblong hoops of diamonds enclosing a splendid turquoise, emerald and diamond drop earrings in square or lozenge shape, or several fancy stones set in a line tipped with gold and almost falling to the shoulders.

In the semi-precious stones the amethyst seems the most popular, and those used in necklaces and brooches associated with pearls or diamonds being made in infinite variety. Small crosses of pale or deep purple amethysts enhanced with small diamonds are fashionable; in fact, the cross of precious stones, rather small, is a feature

of this season's jewelry. Topazes and pearls are a favorite combination.

Among novelties in fancy jewelry is art enamel in exquisite *champleve*, with the green and blue peacock tones finding an admirable expression. The designs are rather archaic, many of them being reproductions of ancient Pompeian jewelry. They also take the form of great dragon flies, butterflies and beetles, sometimes in the iridescent blues and greens, or in lovely purple hues shading from the richest violet into the paler lilacs. There are linked flower necklaces, cloak clasps, belts, pendants and bracelets. Some of the more expensive examples are set with baroque pearls and now and then a semi-precious stone.

The back and side combs are very handsome, with plain or open work tops usually in the drake's neck or pigeon throat coloring. This art jewelry, while not cheap, is far from expensive.

Rather pretty are brooches simulating a bar of music, the jeweled notes spelling the word "Dearest."

Hearts of translucent enamel with pearl centers are pretty. The rage for Persian effects is shown in heart and lozenge pendants in mixed Oriental colors expressed in varicolored enamels.

Toilet sets of tortoise shell are revived and have a design or monogram in silver on the back.

Silver gilt tea sets and even entire table services are the height of fashion. In shape they run to the rather high James I. style or the squat Queen Anne. Plain or fluted rather than etched or repoussé designs are preferred. Many show elaborate handles of carved ivory, such as a nude female figure, etc.

Many mascots are sold of New Zealand green stone in the form of queer animals. These are in demand by bridge players to be worn as a fetich.

COMTESSE DE MONTAIGU.

Queen Victoria's Coronation Ring.

WHEN Queen Victoria's coronation took place it was discovered that the coronation ring was made too small for her wedding finger. When the archbishop placed it, as a sign of the sovereign's wedding to her nation, there was considerable difficulty in getting it off again—an omen of her long reign.

Another peculiar feature of this official trinket was that she kept her coronation ring always at hand. Hence it rarely, if ever, appeared on show when the other coronation regalia were exhibited to the public.

Wolf Kern, a watch repairer at 338 S. Washington Ave., Scranton, Pa., recently reported to the police that 14 watches had been stolen from his establishment. The watches range in value between \$1.50 to \$10. George Morris, of Buffalo, who was subsequently taken into custody, admitted that he knew something of the robbery, but refused to disclose where the watches were. Two detectives, however, finally found eight of the timepieces, and it is expected that the remainder will be secured without any difficulty.

LOUIS KAHN

MOSES KAHN

SAMUEL H. LEVY

L. & M. Kahn & Co.

Importers and Cutters of

DIAMONDS

170 Broadway, cor. Maiden Lane, New York

AMSTERDAM 2 TULP STRAAT

CUTTING WORKS 29 GOLD STREET

Arnstein Bros. & Co.

Importers and Cutters of

DIAMONDS

65 Nassau Street

New York

LONDON: Audrey House, Ely Place

AMSTERDAM: 6 Tulp Straat

ALBERT LORSCH.

N. Y. Telephone Call, 2161-2 John.

ALFRED KROWER

ALBERT LORSCH & CO.

LORSCH BUILDING, 37 and 39 MAIDEN LANE, NEW YORK

131 Washington Street, Providence, R. I.

HEADQUARTERS for CORAL

Coral Cameos

Coral Boutons

Coral Strings

Coral Pendants

Coral Flowers

Coral Cabochons

The Effect of Radium on Corundum Gems.

Interesting Experiments Made by Rochester Scientist on the Lines of the Work of Prof. Bordas. How Prof. Bordas Changed Valuable Gems into Less Valuable Crystals.

ROCHESTER, N. Y., Feb. 5.—The recent work of George B. Selden, Jr., who has been experimenting along the lines of those followed by Prof. Bordas, of Paris, in changing the color of corundum crystals by means of radium has caused considerable interest in the scientific world and some interest in the jewelry trade, and has been the subject of no small amount of newspaper notoriety. As is usual in cases of this kind, however, the newspaper accounts give no adequate idea of what Mr. Selden had done, the writer either not understanding his experiments or wishing to emphasize a certain part of the work that might be used with sensational effect. In any case, the mass, or if not all of the accounts were incorrect, and THE CIRCULAR-WEEKLY, therefore, through its correspondent, obtained the statement from Mr. Selden himself in order that the trade might obtain a proper knowledge of what had been done.

As will be seen from the statement given by Mr. Selden to THE CIRCULAR-WEEKLY correspondent, his experiments, though of little value from a commercial standpoint, are interesting scientifically, and also are valuable in bringing out points that were not made clear in the account of Prof. Bordas' work in Paris, particularly in regard to that part of his work that showed that the change in tint and in crystal produced by radium could be counteracted by subjecting the color gem to a high temperature.

Mr. Selden says:

"I placed some radium bromide of an activity of 1,800,000, produced by Madame Curie, in a small round brass box. Within an eighth of an inch of the radium I placed six different corundum crystals or sapphires, Al_2O_3 . The box was then covered with a mica cover. In a two-carat stone after being exposed for two days a faint yellow color appeared; after four weeks the stone had changed in color to as near as I can make it, rye whiskey.

"Exposing it for another week made no further change, and it was taken away from the influence of the radium. Five days after it was removed from the radium the color began to fade, and in two weeks had faded to a straw color.

"Being placed near the radium again the color started to come back. When subjected to the heat of a Bunsen burner at a temperature of 800 the stone in a fraction of a second lost all the color given by the radium, but retained a luster and brilliancy slightly better than before it was subjected to the radium. The stone was in no way injured. This same stone after being subjected to the Bunsen flame was again put under the influence of the radium, and in six days regained the whiskey color it had taken five weeks to obtain in the first place. A topaz which was experimented with took three days to color."

Mr. Selden will conduct further experiments with different stones in the hope of finding out just what affects the change in

the stone. Mr. Selden does not believe the discovery interesting commercially, although a sapphire subjected to radium will retain the deep and hence more valuable color for some days after being taken from the radium, just making it possible to palm off the stones unless they were subjected to the heat test.

A rhinestone exposed to the radium for about a month is turning to a violet color.

In connection with Mr. Selden's experiments the following article from the *Literary Digest* and the quotation it contains from *La Nature* on Professor Bordas' experiments are most interesting and serve to throw a new light on the effect of his work. The *Literary Digest* says: "The report, noted in these columns, that a Paris mineralogist had succeeded in changing comparatively valueless crystals into rubies and sapphires, would appear to have a slender basis of fact. There was, it is true, a 'transformation,' but it was the other way about, gems being turned into worthless crystals by the action of radium—a change as interesting from a scientific point of view as the other would have been, but hardly from that of the jeweler. In *La Nature* (Paris, Nov. 9) P. Sallier describes the interesting experiments of Bordas, which were these alluded to in the Paris newspapers, and tells us their possible significance. He writes:

The daily papers, with their usual powers of amplification and deformation, are now making much of the interesting experiments performed by Mr. Bordas on the coloration of corundum, rubies, and sapphires, and the occasion has been seized to celebrate the triumph of the alchemists, to announce the realization of transmutation, etc., while jewelers have been promised an invasion of rubies and sapphires prepared cheaply by the action of radium on plain corundum (or adamantite spar). This kind of announcement . . . now makes no impression on sane people, who have been prepared by recent events to understand that it is well to distrust such extraordinary results as "life created by radium," "plants produced by mineral salts," and so on. Our readers will therefore be glad to know the really interesting results obtained by Mr. Bordas in his investigations.

Commercially and practically the author hastens to rectify the journalistic imagination by noting that hitherto he has only changed valuable gems into comparatively worthless corundum, and this by using radium, which is extremely valuable—exactly the opposite transformation to the one reported. It is possible that we may realize some day, under different conditions, the inverse reaction; but this has not yet been done. We must not forget that the fabrication of synthetic rubies and sapphires, artificial and yet mineralogically real, has been carried on for some time on a large scale. There remains only the scientific question. In the first place there has been absolutely nothing in any way resembling a transmutation. All mineralogists know that corundum, ruby and sapphire are one and the same mineral, variously colored, and consisting of a compound of aluminum.

Artificial syntheses produce simultaneously rubies and sapphires. The only question, therefore, relates to the origin of the coloration. This was formerly attributed to traces of different foreign substances, such as manganese and chromium, but since the discoveries of Curie it has been supposed rather to be due to variations in the condition of one and the same substance. . . . That the idea followed up by Mr. Bordas has been "in the air" for a long time, is shown by the following quotation from an article published 18 months ago by Mr. De Launay regarding the variable coloration of tourmaline: "It would be interesting," says this author, "to examine these phenomenon of color-

ation in the light of the new ideas suggested by the recent experiments of Curie. He succeeded in changing white quartz into smoky quartz, clear alumina into brown alumina, and white glass into violet glass, by the simple action of radium, and this new coloration of the mineral lasts as long as they are not subjected to high temperature. Many variations in the color of natural crystals, which are insufficiently explained by supposing the addition of foreign substances, might perhaps find a better interpretation by reference to similar reactions."

This is precisely what Mr. Bordas has done. By bombardment with radium, corundum becomes yellow, sapphire turns green, ruby passes through violet, blue and green to yellow. The geologic conclusion would be that aluminum must, in many cases, have crystallized first as ruby, and that sapphire, topaz, and finally corundum, are successive stages of degeneracy under the action of radium, which is contained in almost all subterranean waters, just as analogous action would change clear rock-crystal into smoky quartz. There is evidently much to be done in the way of investigation along this line (diamonds of various colors, etc.), especially in view of the fact that high temperature, so often a factor in geologic phenomena, would appear in certain cases to produce an effect inverse to that obtained by radioactivity. Analysis of the conditions of occurrence of colored gems together with new experiments, may throw additional light on their mode of formation.

The Carnegie Trophy.

THE illustration on the front page of this issue shows two views of the beautiful Carnegie trophy made by the Gorham Co. for Mr. and Mrs. Andrew Carnegie and presented as a perpetual trophy for inter-class regattas to be held on Lake Carnegie at Princeton. The cup is hand-wrought and is a most artistic example of the silver-smith's art.

The trophy is of sterling silver, stands $3\frac{1}{2}$ inches high, and is mounted on a square base of $8\frac{1}{2}$ inches, decorated with hammered raised work representations of dolphins, fish and other denizens of the deep. On the front of the cup is the following inscription, "Presented by Mr. and Mrs. Andrew Carnegie as a trophy to be competed for at the annual class regatta, Princeton University, on Lake Carnegie." Above the inscription is the Princeton shield, bearing the Princeton coat-of-arms in colored enamel. The cup is of classical shape and has two handles which start from the body part, and gracefully curving, meet the cup again at the top. On the reverse beneath crossed oars is a place for engraving the names of the successful members of the different crews. The inscription, which has already been placed thereon, is as follows: "Won by the class of 1910," and following this the names of the oarsmen who made up the successful crew. The cup will be held as a perpetual trophy and will be presented to the successful class as it is won each year.

In the manufacture of this cup the system employed is that of the old hand-wrought work. No machinery or tools of any kind was used in the work. The design, however, is entirely new.

The American Jewelry Co., Oakland, Cal., recently sustained a loss of \$1,000 by fire.

Captain Charles F. Brown, at one time well known in the jewelry trade in Hot Springs, Ark., died in St. Louis, Mo., about a week ago, aged 74 years. The deceased was a well-known mineralogist and had a valuable collection of minerals, which he exhibited at the St. Louis Exposition.

EDUARD VAN DAM

CUTTER OF

DIAMONDS

CUTTING SHOPS:

ANTWERP

41 Rue de la Province (Sud.)

CABLE ADDRESS, MADNAV

NEW YORK

437-439 Fifth Ave.
Cor. 39th St. Knabe Bldg.

TELEPHONE, 5879 38TH ST.
CABLE ADDRESS, DEVRIVAN

AMSTERDAM

55 Ruysdaelstraat

CABLE ADDRESS, MADNAV

LONDON OFFICE, 22 Holborn Viaduct

THE HERMAN KECK MANUFACTURING CO.

CUTTERS OF

DIAMONDS

19-21 WEST FOURTH STREET CINCINNATI, OHIO

OPPENHEIMER BROS. & VEITH.

CUTTERS OF DIAMONDS.

CUTTING WORKS

65 NASSAU STREET,

43-45-47 JOHN STREET

NEW YORK.

AMSTERDAM

2 Tulpstraat

LONDON

40 Holborn Viaduct

MEYEROWITZ BROS.

IMPORTERS OF

DIAMONDS

PRECIOUS and
SEMI-PRECIOUS STONES

ESTABLISHED 1896

NEW YORK: 37-39 Maiden Lane
PARIS: 58 rue de Maubeuge
AMSTERDAM: 2 Tulpstraat

MEYEROWITZ BROS

MEYEROWITZ BROS

Bids Received and Contracts Awarded by Government to Supply Various Articles.

WASHINGTON, D. C., Feb. 5.—Bids have been opened by the Quartermaster's Department, Philadelphia, as follows:

For 5,000 table forks—Ernest Law & Co., Philadelphia, Pa., \$3.11½ or \$2.88 per dozen; J. B. Shannon & Sons, Philadelphia, Pa., 27c. each; Paul J. Devitt, Philadelphia, Pa., 23¼c. each; L. Barth & Sons, New York, 25¼c. each; Jos. N. Snellenberg, Philadelphia, Pa., 26c. each; John Wanamaker, Philadelphia, Pa., \$3.51 per dozen; J. M. Vance & Co., Philadelphia, Pa., \$3.12 per dozen; James K. Shaw, New York, \$2.89½ or \$3.07½ per dozen; Albert Pick & Co., Chicago, 26¼c. each; Jos. N. Earley, New York, 25.97c. each; Manhattan Supply Co., New York, 25.9c. each.

For 5,000 table knives—Ernest Law & Co., \$2.17 or \$2 per dozen; J. B. Shannon & Son, 19¼c. each; Paul J. Devitt, 17.9c. each; L. Barth & Son, 17.9c. each; Jos. N. Snellenberg, 18¼c. each; John Wanamaker, \$2.25 per dozen; William Hodges & Co., Philadelphia, Pa., 18¼c. each; J. M. Vance & Co., \$2.29 per dozen; James K. Shaw, \$2.10 per dozen; Albert Pick & Co., 18c. each; Jos. N. Earley, 18¼c. each; Manhattan Supply Co., 18.99c. each.

For 2,000 table spoons—Ernest Law & Co., \$3.12 per dozen; J. B. Shannon & Son, 27c. each; Paul J. Devitt, 23¼c. each; L. Barth & Son, 25¼c. each; Jos. N. Snellenberg, 26c. each; John Wanamaker, \$3.51 per dozen; J. M. Vance & Co., \$3.12 per dozen; James K. Shaw, \$2.89½ or \$3.07½ per dozen; Albert Pick & Co., 26¼c. each; Jos. N. Earley, 25.97c. each; Manhattan Supply Co., 25.9c. each.

WASHINGTON, D. C., Feb. 6.—The Navy Department, through the Bureau of Supplies and Accounts, is calling for proposals for the following items, bids for which will be received until Feb. 18:

To be delivered at the Washington Naval Observatory—15 boat clocks; 10 deck clocks, No. 1; 25 deck clocks, No. 2; 20 quartermaster's spyglasses, medium power; 10 quartermaster's spyglasses, medium power; 50 spyglasses for officers of the deck; 50 air thermometers, 50 water thermometers, 50 day binoculars, 50 night binoculars.

These binoculars are to have brass cell fittings, objective diameter of two inches, a minimum eye distance of 2.35 inches. The eyepiece must also be provided with a movable amber-colored ray filter working wholly within the eyepiece cap.

Also 20 prismatic 10-power binoculars, object glass 1.75 inches, eyepiece to be provided with amber-colored ray filter, jointed frame, buff-leather finish, and to be provided with buff leather carrying case.

WASHINGTON, D. C., Feb. 8.—The Bureau of Supplies and Accounts, Navy Department, has received the following bids:

For a quantity of silver plated table ware for the Brooklyn yard, International Silver Co., Meriden, Conn., \$1,877.30.

For one dozen glazier's diamonds for the Boston Bureau of Construction & Repair: Frances & Co., Hartford, Conn., \$42; Holbrook Bros., New York, \$34.80; Knox &

Bro., New York, \$35; Manning, Maxwell & Moore, New York, \$35.75; Montgomery & Co., New York, \$18; Shoemaker & Bonsch, Philadelphia, Pa., \$35.10; Excelsior Equipment Co., Pittsburg, \$37.50; Frye-Phipps Co., Boston, Mass., \$11.50.

WASHINGTON, D. C., Feb. 10.—The Navy Department has announced the following awards:

For 300 cut glass tumblers, Mare Island Navy Yard, Jenkins Mfg. Co., New York, \$80.70

Thermometers and hydrometers, Mare Island Navy Yard, A. E. Moeller, Brooklyn, N. Y., \$831.60

Career of the Late Isaac Lloyd Blauvelt.

Isaac Lloyd Blauvelt, one of the oldest and best known salesmen in the New York jewelry district, died at his home, 76 E. 91th St., Wednesday, Jan. 29, as the result of a stroke of apoplexy. Mr. Blauvelt was one of the oldest active salesmen in the trade and spent practically his entire life in the jewelry business, during which time he formed a wide circle of friends and acquaintances who learned with regret of his death.

He was born Oct. 1, 1828, in New Rochelle, N. Y., where he spent his early life. When 12 years of age he came to New York City and became connected with the firm of Merrill, Fitch & Allin as an office boy, with whom he stayed for some time, gaining the confidence and respect of his employers. Later he went with Cooper, Fellows & Co. as a traveling salesman, covering New York State and the east. About 1860 he went with Alling Bros. and was taken into the firm in 1861; he retired from this firm in 1862 and became connected with Samuel W. Chamberlain as business manager and salesman. After being for some time with Mr. Chamberlain he became a representative for Moore & Horton, and about 30 years ago became associated with the firm of J. B. Bowden & Co., with whom he remained as a city salesman. The period of his service with his firm covered over 30 years, during which time he came to be highly regarded by his employers. He was a remarkably active man for one of his years, and worked up to within a short time of his death.

Mr. Blauvelt is a grandson of the Rev. Isaac Blauvelt, who was at one time connected with the Dutch Church at New City, N. Y., and later pastor of a church at Fishkill, N. Y. The deceased is survived by a daughter, Emma Alstein, and one son, Isaac. His wife died about eight years ago. He was a member of the Acacia Lodge, 327 F. & A. M., and a member of Company H, of the 71st Regiment Veterans' Association.

There is perhaps no one salesman in the New York jewelry district who was better or more favorably known than the deceased. A number of friends and acquaintances in the trade gathered at his late home, Feb. 1, to pay their last respects. The funeral was held from his home. Interment took place at Beach Woods Cemetery, New Rochelle.

W. C. Luhrs has purchased the interests of his partner, T. O. Major, Billings, Mont., in the store at Red Lodge, Mont.

Assets and Liabilities of Edwin W. Dayton, N. Y., as Shown by His Bankruptcy Schedules.

Schedules in bankruptcy of Edwin W. Dayton, a jeweler and salesman, 4 W. 39th St., New York, against whom a petition in bankruptcy was filed some time ago in the United States District Court, New York, Wednesday of last week, show liabilities of \$16,935, with assets consisting of stock sold by the receiver, \$350; debts due on open accounts, \$110; claims against J. Edward Beck amounting to \$48,000, which represents the amount of jewelry taken by Beck from the bankrupt.

Among the secured creditors are: Alfred H. Smith & Co., Ludwig Nissen & Co., The Jersey City Stores and Marie von Hoften. The unsecured creditors include: Maurice Barnett, \$131; White & Phipps, \$521 (for rent); Rudolph A. Breidenbach, \$118; Cooper Diamond Co., \$112; Crossman & Co., \$100; Lucian A. Dubemet, \$178; Elite Mfg. Co., \$129; Fishel, Adler & Schwartz, \$178; Fetzer Press, \$106; Frost & Reed, \$133; Geiger & Bauer, \$738; Geofroy & Co., \$218; Henry Graves & Co., \$109; Howard & Cockshaw, \$199; Frank Kursh, Son & Co., \$385; Kamm & Bertheisel, \$44; Knight & Knight, \$114; Pietro Miliam, \$204; L. S. Meyer, \$612; Nonnenbaker & Co., \$264; Alfred H. Smith & Co., \$109; Unger & Christie \$202; Gustavus A. Veeck, \$153; Van Dusen & Stokes Co., \$112; Oppenheimer & Stern, \$212; H. E. Oppenheimer & Co., \$1,337; Osmers-Dougherty Co., \$1,645; Albert Strehan, \$170; Rudolph Kohlhepp, \$273; Chas. P. Goldsmith & Co., \$2,364; E. Karselsen & Co., \$530; B. Michael & Co., \$185; New Amsterdam National Bank, \$1,587; Frank V. Burton, \$635.

Massachusetts Optometrists Take Steps to Oppose Bill Which Hits at Their Business.

BOSTON, Mass., Feb. 7.—Opticians and optometrists are to oppose a bill which has been introduced into the Legislature of Massachusetts, and which, it is said, if enacted into a law, would compel optometrists to take a course in medicine before examining eyes. A hearing on the bill is to take place Tuesday, Feb. 18, at 10.30 A. M.

Briggs S. Palmer, chairman of the Legislative Committee of the Massachusetts Optical Society, has sent out the following notice:

There has been introduced into the legislature of the Commonwealth of Massachusetts, a bill which, if it is passed, might compel opticians and optometrists to take a course in medicine or else give up examining eyes. It is House Bill No. 910, and a strict interpretation of it would legislate opticians out of business. We believe that the bill is aimed at us and all opticians and optometrists in this Commonwealth ought to be present at the hearing on Tuesday, Feb. 18, at 10:30 A. M., and oppose this bill. A little time from your business now may save a great deal of trouble in the future.

The bill which the Massachusetts Optical Society has introduced to regulate the practice of optometry (House Bill No. 538), will be given a hearing before the Public Health Committee on Thursday, Feb. 20, at 10:30, Room 444, State House, Boston. All opticians and optometrists who are interested in the elevating of their profession should not fail to be at this committee hearing.

Do not forget that the legislative work incident to these two bills requires considerable money, and it is earnestly hoped that our treasurer, W. P. Bullard, 12 Milk St., Boston, will receive your contribution at an early date.

To show our absolute confidence in the stability of the prices of Diamonds we will add to all bills purchased from us, from this date on, the following guarantee:

If at maturity of this bill the market prices are less than those charged for the above goods, we guarantee to refund the difference between the then existing market prices and the prices charged on this bill.

CYRUS PRICE & COMPANY
NEW YORK

Post-Office Inspectors Take Charge of Money Order Swindler and Check Forger Arrested at New Haven.

Louis Ammerman, the 26 year old money order and check forger, who has been giving the post-office officials a great deal of trouble since last November, and who was arrested in New Haven, Conn., as told in last week's CIRCULAR-WEEKLY, has been turned over to the federal authorities by the State courts in Connecticut, and is now being held under \$2,500 bail to await action by the United States Grand Jury, Feb. 25.

Ammerman was arrested, Jan. 31, in New Haven, by Detective Donnelly on information furnished him by Post-Office Inspector Thomas M. Reddy, who has had charge of the case, and to whom the greater



LOUIS AMMERMAN, MONEY ORDER AND CHECK FORGER.

share of credit is due for the clever and expeditious manner in which the offender has been brought to justice.

The story of the young man's career as a fugitive from the law begins with his appearance at Lewistown, Me., early last November, at which time he opened negotiations with W. A. Oxnard, a druggist, to buy out the business. He presented alleged letters of recommendation and won Mr. Oxnard's confidence, and with a letter of recommendation from him succeeded in getting a check for \$100 cashed at a local bank, where he opened an account by depositing a fraudulent check for \$18,000 drawn on the Corn Exchange Bank, New York.

He next went to Portland and there cashed several checks; going from there to Boston he visited the drug store of a Mr. Curtis, in which is located post-office station 82. He again bargained to buy out the business and at an opportune time, when Mr. Curtis was out to lunch, succeeded in getting possession of a money order form and tore out and stamped several blanks.

He next appeared in Jamaica Plains and cashed several checks over forged names and from there went on to Worcester and

passed bogus money orders on several merchants. From there he came to New York and began spreading money orders broadcast. Among the jewelers whom he visited in the Metropolis were Lindo Bros., where he cashed an order for \$50, a part of which he spent for jewelry. At the store of Bernheim & Co. he presented an order for \$10 and with Otto Goldsmith he cashed one for \$50, in each instance buying some jewelry.

Leaving New York, Ammerman went into New Jersey and from there to Bridgeport, Conn., where he cashed a money order for \$50 with Mark Wiststein, buying \$29.50 worth of rings, fobs, etc. He also visited J. P. Meyers & Co., and cashed an order for \$10, buying \$35 worth of jewelry.

He later returned to New York and at a drug store in which station 193 is located, stole a book of money order forms, which have since been recovered. He then returned to New Haven, Conn., and was posing as a collegian when arrested.

The prisoner made a confession to Inspector Reddy, admitting his guilt and saying that he had worked alone. He used several assumed names and during his brief, yet brilliant, career, he passed about 75 money orders of from \$25 to \$50 in value. Jewelers in the east will watch the trial with interest.

Creditors File Bankruptcy Petition Against Chase Mfg. Co., Providence, R. I., After Assignment Had Been Made.

PROVIDENCE, R. I., Feb. 6.—A creditors' petition in bankruptcy was filed yesterday afternoon against William A. Greene, doing business as the Chase Mfg. Co., by three creditors. The petition was presented in the United States District Court and a hearing has been set in the matter for Thursday morning at 10 o'clock. The creditors who filed the petition are George W. Dover, who claims that \$454 is due him; Edwin Lowe Gold Plate Co., with claims of \$110.43, and the T. W. Lind Co., with claims of \$81.80.

The prayer of the petitioners is to the effect that the Chase Mfg. Co. should show cause why it should not be declared bankrupt, as it has made a general assignment to William M. P. Bowen, an attorney. The assignment was made on Jan. 24. The company was engaged in a mail order business.

The business was established in January, 1897, by C. C. Chappell, C. L. Cabot and L. K. Potter, adopting the firm style of Chappell, Cabot & Co. They were succeeded by Chappell & Cabot in July, 1898, and later the business was sold to Walter A. Chase and William A. Greene. Mr. Chase was for 10 years previously bookkeeper for Hancock, Becker & Co., and Mr. Greene was his father-in-law. Mr. Chase died June 20, 1906, and Mr. Greene continued the business.

John Hoppersburger, Jr., contemplates opening a watch and jewelry repairing shop in Middletown, O., in the near future.

The Alpha Drug & Jewelry Co.'s store, Rugby, N. Dak., has been purchased by R. F. Lussier, formerly of Cass Lake and Foley, Minn.

Jewelry, Clocks, Watches, Silverware and Kindred Lines Exported from New York.

WASHINGTON, D. C., Feb. 5.—The following were the exports of jewelry, silverware, optical goods, clocks, watches and kindred lines from the Port of New York for the week just ended:

Ballao: 2 cases plated ware, \$180; 10 cases clocks, \$125.

Batavia: 1 case watches, \$100; 1 case jewelry, \$320; 1 case watches, \$466; 6 cases clocks, \$195.

Bremen: 2 cases plated ware, \$200; 1,383 cases plated ware, \$6,346.

Bombay: 3 cases watches, \$677; 9 cases clocks, \$529.

Buenos Ayres: 61 cases clocks, \$3,550; 1 case silverware, \$550; 2 cases watches, \$2,548; 2 cases jewelry, \$156; 3 cases optical goods, \$976; 3 cases plated ware, \$291.

Buenaventura: 1 case jewelry, \$576.

Delagoa Bay: 7 cases clocks, \$133.

Cartagena: 10 cases clocks, \$600.

Christiania: 4 cases clocks, \$192.

Colon: 3 cases clocks, \$100; 2 cases plated ware, \$377; 7 cases optical goods, \$519; 2 cases clocks, \$766; 1 case plated ware, \$246.

Coronda: 2 cases jewelry, \$196.

Corinto: 4 cases clocks, \$121.

Curacao: 1 case optical goods, \$160; 5 cases plated ware, \$222.

Grand Bassa: 2 cases organs and material, \$156.

Guayaquil: 4 cases clocks, \$195.

Genoa: 1 case jewelry, \$300; 1 case optical goods, \$340.

Glasgow: 10 cases clocks, \$500.

Hamburg: 1 case plated ware, \$690; 2 cases optical goods, \$212; 1 barrel jewelers' sweepings, \$1,500; 10 cases jewelers' sweepings, \$4,000; 2 cases optical goods, \$1,019.

Havre: 7 cases watches, \$706; 3 cases jewelry, \$500.

Havana: 2 cases optical goods, \$134; 5 cases jewelry, \$1,539.

Hong Hong: 21 cases clocks, \$406; 1 case watches, \$3,587.

Kingston: 6 cases clocks, \$147; 2 cases plated ware, \$101.

Limon: 1 case plated ware, \$287; 2 cases plated ware, \$123.

Liverpool: 4 cases plated ware, \$292; 3 cases clocks, \$385; 1 case silverware, \$158; 2 cases jewelry, \$610.

London: 26 cases clocks, \$150; 6 cases plated ware, \$302; 6 cases optical goods, \$1,049; 1 case jewelry, \$245; 14 cases watches, \$2,471; 80 cases clocks, \$1,728.

Matanzas: 8 cases clocks, \$129.

Maracaibo: 1 case clocks, \$100.

Melbourne: 3 cases optical goods, \$150.

Mollendo: 1 case watches, \$679.

Montevideo: 28 cases clocks, \$498.

Naples: 2 cases jewelry, \$300.

Para: 3 cases watches, \$277; 15 cases clocks, \$245.

Port Elizabeth: 15 cases clocks, \$449.

Trinidad: 2 cases watches, \$116.

Tumaco: 5 cases clocks, \$199.

Sanchez: 4 cases jewelry, \$146.

Santiago: 9 cases plated ware, \$324.

Savanilla: 8 cases clocks, \$160.

Sheffield: 1 barrel jewelers' sweepings, \$1,700.

Vera Cruz: 2 cases plated ware, \$172; 2 cases optical goods, \$129.

Yokohama: 80 cases clocks, \$1,577.

It was reported last week that a collection of jewels supposed to have belonged to the wife of Seti, the second of the reputed Pharaohs of the Exodus was found recently in the Valley of Tombs at Thebes, where presumably it was interred with its owner about 1,500 years before Christ. It is stated that the collection comprises heavy gold bracelets, earrings several inches long, elaborate rings and gold fillets. They were found imbedded in mud, where they were probably thrown by robbers who in a bygone age plundered the Queen's tomb, which is empty. The report of the find created considerable interest.

Not One Stone

has ever come near attaining the popularity of the Reconstructed Ruby—the Hope Sapphire following next. * * * Comparatively inexpensive, these two Gems are within the reach of all, their demand increasing rapidly with their introduction to the general public.

* * * We have realized that these Scientific Gems are articles that have come to stay, and have accordingly equipped ourselves for their uninterrupted production. Our facilities for cutting these stones enable us to fill all possible orders without delay.

L. Heller & Son

Importers of Precious and Imitation Stones
68 NASSAU STREET, NEW YORK

PARIS
39 Rue de Chateaudun

PROVIDENCE
212 Union Street

IDAR
14 Hauptstrasse

ORDER

DIAMONDS

ON MEMORANDUM FROM

ALFRED H. SMITH & CO.

170 BROADWAY, NEW YORK

Corner Maiden Lane.

Also 475 FIFTH AVENUE

London,
8 Holborn Viaduct.

Chicago,
103 State Street.



1806 D

Horse Shoe and Circle Brooches

The only complete line of these goods in the market mounted with American Baroque Pearls. All sizes.

CROSSMAN COMPANY

THREE MAIDEN LANE

NEW YORK



1186

RUDOLPH NOEL

PHILIP NOE

RUDOLPH NOEL & CO.

IMPORTERS AND CUTTERS OF DIAMONDS

2 Tulp Straat, AMSTERDAM

37-39 Maiden Lane, NEW YORK

Robert M. Vail Acquitted of Charge of Complicity in Theft from Jewelers' Trunk.

SCRANTON, Pa., Feb. 8.—Robert M. Vail, the jeweler who has been on trial in the Criminal Court in this city, charged with complicity in the robbery of about \$2,500 worth of diamonds and jewelry from the trunks of M. Rosenbloom & Co., Rochester, N. Y., has been exonerated, the jury after several hours' deliberation having brought a verdict of not guilty.

The robbery took place on Christmas Day while the trunk was in Mr. Vail's store, and F. W. Millar, a massage artist, who was later arrested for the crime, confessed but tried to implicate Vail, stating that he had committed the act at the instigation of the latter. The strenuous denial of the jeweler, coupled with the testimony of many witnesses as to his honesty and good character, caused the jury to disbelieve Millar's story.

Millar, the self-confessed thief, claimed that Vail had given him a key to the store and told him that he was hard up, and not only suggested that the diamonds be stolen, but also that he (Vail) be attacked, chloroformed or hit on the head. Millar claimed that this plan was abandoned, but that he stole the jewels and that he had given two of them to Vail.

Vail, who was really responsible for the arrest of Millar by telling the authorities that Millar had an extra key to the store, took the stand in his own defense and denied the Millar story in toto, particularly the statement that Millar had given him two of the diamonds, and that he had urged Millar to run away, and had given him money to leave Scranton. While admitting that he knew Millar had the key to his store, he said he did not tell this to the police at first because he did not wish to throw suspicion on Millar, whom he believed innocent. He claimed that he knew nothing at all about the robbery until after Millar's arrest and confession.

There was practically no evidence against Vail, except that of Millar, the only other important witness being A. M. Weinberg, a salesman of Rosenbloom & Co., who had charge of the trunk that was left in the store, and who testified that Vail and Millar were both in the store on the day that the diamonds were taken.

The judge charged the jury that to sustain the charge there must be other evidence corroborating that of the thief, and the jury thereupon acquitted Vail.

After the verdict had been rendered Millar pleaded guilty to the charge and was remanded until to-day, when he was sentenced to one year in the county jail.

Assets and Liabilities of David Kessler as Shown by His Schedules.

Schedules in bankruptcy of David Kessler, 226 Henry St., New York, filed in the United States District Court, last Friday, show liabilities of \$11,663 and assets of \$9,795, consisting of notes \$1,373, and accounts, \$8,422.

Among the unsecured creditors named in the schedules are: Herman J. Dietz, \$450; S. Kaplan Co., \$7,600; D. Kalman, \$1,500; J. Macher, \$373; Kleinberg & Probst, \$217; Baumgold & Son, \$250; Lieberfriend Bros., \$300; M. Greenspan, \$273. The bankrupt also endorsed notes for M. Greenspan to the amount of about \$11,000 and for Louis Halpert for about \$1,900.

A petition in bankruptcy was filed against Mr. Kessler in December.

Thief Assaults Aged Albany, N. Y., Jeweler With Lead Pipe Bludgeon, in Attempt to Rob Him.

ALBANY, N. Y., Feb. 6.—Albert Lawtenslager, an aged manufacturing jeweler, whose quarters are on the second floor of 71 N. Pearl St., was a victim of a brutal thief, who, in his attempt to rob Mr. Lawtenslager's place, assaulted the latter with a lead pipe, and nearly killed him in the attack. The thief escaped, but later the detectives arrested Charles Donovan and John Hefferman on the charge, and Mr. Lawtenslager identified the latter as his assailant.

Mr. Lawtenslager, who is 87 years old, was alone in his store yesterday morning when a young man entered and asked the cost of monograms. The jeweler, who had been sitting by the fire reading, started for the place where he kept his samples of monograms, but as he was about to pass through the door into another room the stranger pulled a piece of lead pipe out of a newspaper and struck the jeweler across the back of the head. Fortunately the blow glanced instead of striking squarely, or the jeweler's skull would have been smashed.

Mr. Lawtenslager, though stunned, turned upon his assailant. The man tried to strike another blow, but Mr. Lawtenslager held his arm so that this was impossible, in the meantime shouting for help. The stranger then broke away and escaped.

The police were notified and obtained a description of the assailant, later arresting Hefferman and Donovan. Mr. Lawtenslager identified Hefferman as the robber, and the identification was strengthened by a plumber, who said that the pipe with which the jeweler had been assaulted had been purchased from him and that Hefferman was the purchaser. Donovan was held as an accomplice of Hefferman.

Death of Emanuel Hibarger.

HAGERSTOWN, Md., Feb. 5.—Word has just been received that Emanuel Hibarger, for many years a jeweler of this town, had died at Roanoke, Va., Monday afternoon. His death was due to stomach trouble from which he was a sufferer for some time.

The deceased, who was a native of Sharpsburg, came to Hagerstown as a young man and engaged in business as a watchmaker and jeweler. While here he was a prominent wheelman and an active member of the Bicycle Club. He left Hagerstown for Roanoke to be an inspector of watches for the Norfolk & Western Railway, and conducted a jewelry store there until about a year ago, when ill health compelled him to retire from active business.

Mr. Hibarger is survived by a widow, three daughters and two sons. The remains will be brought to Sharpsburg for interment.

Involuntary Bankruptcy Petition Filed Against Jos. Brown & Co. by Creditors.

CHICAGO, Ill., Feb. 7.—An involuntary petition in bankruptcy was filed yesterday in the United States District Court against Jos. Brown & Co., wholesale jewelers at Fifth Ave. and Madison St. The petitioning creditors were Jules Racine & Co., Swartzchild & Co. and Stevens, Maloney & Co. Racine's claim was for \$5,700. The other two amounts were small. The petitioners claimed that Jos. Brown & Co. had while insolvent paid the Continental National Bank \$2,500. The court appointed the American Trust & Savings Bank receiver under a \$20,000 bond and made a special order of referring the case to Referee Eastman for examination.

Hugo Pam, attorney for the defendant concern, said he believed that it was solvent and that he thought there were resources of \$130,000, of which \$60,000 was in stock and \$70,000 in outstandings, against an indebtedness of \$100,000. Well-informed people in the trade, however, estimate the liabilities at nearly twice the amount reported.

The concern is a corporation with a paid-up capital of \$75,000. Joseph Brown is president and E. Spiro is treasurer. Mr. Brown started in the jewelry business in 1875, prior to which time he was connected with the auction business. In 1896, with Phillip H. Winterberg, he formed the firm of Brown & Winterberg, and that business was incorporated a short time later with a capital of \$20,000, but in 1900 the corporation was dissolved and the partnership resumed. Mr. Winterberg withdrew in 1901 and Mr. Brown continued the business alone until he again incorporated his business under Illinois laws, at which time Samuel M. Jess became the secretary and treasurer. Jess withdrew in 1905, selling his interest to Mr. Brown and Mr. Spiro was made treasurer.

Death of Henry Borsch.

CHICAGO, Feb. 6.—Henry Borsch, one of the oldest and best known opticians in the United States, died here Feb. 3, aged 59 years, after a long illness. The funeral took place to-day from his late residence, 3125 Southport Ave. After services in St. Ignatius' Church, the interment was in St. Boniface Cemetery.

Henry Borsch came to this country 40 years ago from Furth, Bavaria, where his father and grandfather were opticians before him. He engaged in business successively in New York, Philadelphia and San Francisco, and came to Chicago about 30 years ago. At one time he was a member of the firm of Watry & Borsch. He invented and patented the U. S. guard and various other devices.

He is survived by his widow, one daughter and three sons. The business of Borsch & Co., at 215 Dearborn St., is a corporation and will be continued.

Henry Borsch was a brother of John L. Borsch, Philadelphia, widely known for his Kryptok patents.

M. Hirshfield, Butte, Mont., has sold his jewelry store to R. L. Sions, Biddeford, Me.

REGISTERED



TRADE-MARK

AMETHYST JEWELRY

REGISTERED



TRADE-MARK

We have many beautiful and striking pieces in amethysts and combinations of amethysts and pearls, and amethysts and diamonds.

The popularity of amethyst jewelry makes this exceptionally salable stock, and you should certainly have a few representative pieces.

We carry Rings, Necklaces, Brooches, Scarf Pins and La Valliere.

If you have our catalog, well and good—If you haven't, send for it.

REGISTERED



TRADE-MARK

HAYDEN W. WHEELER & CO., Importers
2 Maiden Lane, NEW YORK, N. Y.

REGISTERED



TRADE-MARK

AMSTERDAM, 2 Tulp Straat

'Phone 7365 Cortland

LONDON, 50 Holborn Viaduct

CORAL

All Kinds of Coral Specialties for Jewelers

**DROPS
BUTTONS
LENTILLES**

**CORAL
NECK-
LACES**

All Shades and Sizes
Graduated and Uniform



CORAL MANUFACTURING COMPANY

CORAL

**Extra Rose
CORAL
A Specialty**

Gold Medal
St. Louis, 1904

Grand Prix
Liege, 1905

BORRELLI & VITELLI

3 Via Amedeo,
Terre del Greco Italy

401 Broadway, New York
Telephone, 5412 Franklin

19 Rue d'Hauteville,
Paris, France

F. A. JEANNE

Round and Fancy Shaped Sapphires

5 Square de l'Opera

PARIS, FRANCE

Cable Address

“ GEMFINDER ”

Western Union Code

Recently Published

Gems and Precious Stones

Their Characteristics, Localities of Production
Tests and Some Current Literature

Cloth, Postpaid, \$1.00

Published by

THE JEWELERS' CIRCULAR PUB. CO.
11 John Street, New York

Tel. 4457 } Cort.
4458 }

JOHN M. RICHARD

2 MAIDEN LANE
Room 302, NEW YORK

American Pearls and Baroques

MATCHED PAIRS FOR EARRINGS

The Largest and Finest Assortment in the Market, Mounted and Unmounted.

Providence.

Chas. Waite is in St. Augustine, Fla.

Charles D. Lyons has returned from an extended western trip and reports improved business conditions.

C. F. Munroe, representing George M. Baker's refinery, was in New York on business, last week.

The Browne & Sharpe Mfg. Co., which makes a specialty of fine jewelry tools, has adopted a 15-hour weekly schedule.

W. U. Fry, of Fry Bros., is on a western trip, and sends word home that business conditions out there are improving.

The Silversmiths' Mutual Aid Society, which is comprised of the employes of the Gorham Co., held its 43d annual meeting last week and elected Arthur W. Barrus president.

The O'Gorman Co., conducting a large department store, which has been in the hands of receivers for some months, has been adjudged bankrupt by Judge Arthur L. Brown in the United States District Court.

Warren S. Locke, one of the instructors in the Rhode Island School of Design, who has given particular attention to jewelry and silver designs, has resigned his position to accept an instructorship in the new Technical High School building.

The New England Trust Co., a small bank, which was used to a considerable extent by the operatives of jewelry shops, particularly those employed in the vicinity of Eddy St., has gone into the hands of a receiver. John Beagan, an attorney, has been appointed in that capacity by the Superior Court. The depositors of the bank, led by Finley Howe, an Attleboro silversmith, have retained counsel to protect their interests.

An unknown man, who said he was a jewelry buyer, from New York, but who would not tell the police his name, was robbed of a diamond stud valued at \$225, while he was drinking at the bar of a liquor saloon in this city, Feb. 4. He accused another man, who proved to be a New York traveling man, of having taken the pin, but at the Central Police Station, the drummer proved that he was innocent and was released from custody.

The non-commissioned staff of the Machine Gun Battery gave Capt. E. Merle Bixby, of that command, a farewell luncheon in the armory on Monday evening. Capt. Bixby, who has charge of the silverware department in the Shepard Co. store, is to sail for Europe this week. He expects to make some purchases of old style silver services on the Continent. Before assuming the management of the Shepard Co. silver department, Capt. Bixby was president of the Bixby Silver Co.

The imports during the past week demonstrated the fact that business is constantly improving. From Bremen came five packages of imitation precious stones, from Halifax one package of jewelers' sweepings; from Hamburg two packages of manufacturing metals, and three packages of imitation precious stones; from Havre one package of imitation stones, and from Southampton one package of fancy enamel. The importation of the sweepings from Halifax is looked upon by

local refiners as an evidence that they are making some headway in the Canadian trade. Already the larger refining houses in this city have traveling men doing the Canadian territory at regular intervals, and in many cases have agents on the ground at all times.

Solomon Berlin, a gold refiner, who claims to have a shop at 21 W. 11th St., New York, was robbed of \$1,000 in the Newman Hotel, Thursday evening. He had hung his vest, containing a bill fold with the money in it, in a toilet room, and when he returned to his own room he forgot to take the vest. The next morning when he remembered where he left the vest, he found that garment, but the money had disappeared. The police are tracing a bell-boy, who is suspected of taking the bills.

The Retail Merchants' Association, in which several jewelry storekeepers are interested, is to hold an important meeting on the evening of Feb. 19. The subject under discussion will be a proposed scheme to revise the entire credit system. It is the desire of the members of the association to secure the enactment of a set of laws which will give both the debtor and creditor a square deal and make it impossible for a single creditor to force a debtor into bankruptcy or the hands of the receiver.

All arrangements for the annual banquet of the New England Jewelers and Silversmiths' Association have been completed and the affair will be held Saturday evening in Infantry Hall. As already announced, the principal speaker will be former Senator Joseph S. C. Blackburn, of Kentucky, with Rev. Willard Scott, of Worcester, as the principal fun maker. The seating list closed Tuesday and contained enough names to substantiate the claim of the committee in charge that the affair would be one of the largest ever held by the association. The banquet is to be held under the auspices of the following executive committee. Frank B. Reynolds, of the Cory & Reynolds Co.; George H. Holmes, of George H. Holmes & Co., and Everett I. Rogers, of Parks Bros. & Rogers. A reception will be held by the officers of the association from 6 to 6:30 o'clock, and at 6:45 o'clock dinner will be served. Fay's American Band, with Bowen R. Church, as cornet soloist, will play during the entire evening.

Mr. Huber, of Huber & Bunker, Superior, Wis., has gone to Florida and Cuba in the hope of benefiting his health.

A Newark manufacturing concern has gotten out a new article of jewelry intended for the double purpose of pinning ladies' collars together, besides acting as a supporter, which keeps the collar upright. This new pin has met with unusual favor, for its merits are quickly understood by the fair sex. To neatly fasten a lady's collar has always been troublesome, and this trouble has now been solved by the novelty in question, which consists of an ornamental bar, having at either end a small pin, harmonizing in design with the bar. This article's popularity is deserved, for it combines the useful with the ornamental in a way that is seldom met with. It can be had at various prices to suit all purses.

Attleboro.

TRADE CONDITIONS.

Although a plain statement of fact is that times are comparatively quiet in many of the jewelry factories, yet the past week has brought to light some encouragement. Several of the shops have been taking back laid off help. The transportation companies report more riding into town to the shops, and one of the large silver houses has resumed giving out work to be done in the homes.

Herbert S. Cummings, head colorer for H. L. Thurber & Co., became a benedict last week.

George H. Herrick, of the Geo. H. Herrick Co., is preparing to spend several weeks in the south.

George Heywood, New York representative of the Horton-Angell Co., spent last week at the home office.

The employes of W. E. Richards & Co. banqueted, last week, in honor of the shop team winning the jewelers' bowling league tourney.

Arno E. French and Raymond M. Fay, as French & Fay, opened a place of business Feb. 8 to deal in manufacturing jewelers' supplies.

Charles E. Snell, for 30 years a trusted employe of the late J. M. Bates, head of Bates & Bacon, took his life with illuminating gas last week.

Word has been received from Charles M. Robbins, of the Chas. M. Robbins Co., now touring Mexico and Central America, on a combined business and pleasure trip, that he will return early in April.

The Finberg Mfg. Co., of which Joseph Finberg is head, last week purchased from Charles H. Tappan, of the D. F. Briggs Co., the land on which its factory stands and a considerable area adjoining for improvements contemplated.

Papers were issued last week indicating that at the Republican caucus, Feb. 21, the following will seek town office: Fred L. Torrey, of F. L. Torrey & Son, Walter J. Newman, formerly of the Horton-Angell Co., and Harrison C. Swift, formerly of H. C. Swift & Co.

The citizens are approaching their annual town meeting, and have named a financial committee to recommend a business-like handling of the 1908 funds. It includes Alfred R. Crosby, of Smith & Crosby; Harold E. Sweet, of the R. F. Simmons Co., and Harry P. Kent, of F. W. Weaver & Co.

The Attleboro Mutual Fire Insurance Co. last week elected to office the following manufacturing jewelers: Charles E. Bliss, formerly of Bliss Bros., to succeed Everett S. Capron, a retired manufacturer, as president; George H. Herrick, of the Geo. H. Herrick Co.; Harold E. Sweet, of the R. F. Simmons Co.; Fred L. Torrey, of F. L. Torrey & Son; Raymond M. Horton, of W. E. Richards & Co., and Horace E. Durgin, salesman for the Geo. H. Herrick Co.

The third annual banquet of the Toronto jewelers was held a short time ago, at the St. Charles Hotel, Toronto, Ont.

The Big Stone Gap Jewelry Corporation's establishment, at Big Stone Gap, Va., was destroyed by a fire which broke out at that place, recently, and wrought damage to the business district, amounting to about \$125,000.

Chester Billings & Son

1840

Successors to
Kandel, Barmore & Billings

1908

Importers of Diamonds
Other Precious Stones, and
Pearls, Diamond Jewelry

1840, Kandel & Barmore; 1866, Kandel, Barmore & Co.; 1880, Kandel, Barmore & Billings; 1897, Chester Billings & Son

New York, 58 Nassau Street, 29 Maiden Lane
London: 22 Holborn Viaduct, E. C. Paris: 53 Rue de Chateaudun
Amsterdam: 2 Culp Straat

GEORGE H. HODENPYL.

WALTER N. WALKER.

HODENPYL & WALKER

IMPORTERS OF

DIAMONDS

OTHER PRECIOUS STONES
AND PEARLSMANUFACTURERS OF
FINE DIAMOND JEWELRY

373 FIFTH AVENUE, NEW YORK

Corner 35th Street

Telephone, 5093 Madison Square

CHAS. F. WOOD & CO.

DIAMONDS

1 MAIDEN LANE

NEW YORK

EISENMANN BROS.

IMPORTERS OF

Pearls and Precious Stones

452 Fifth Avenue, New York
cor. 40th St., Knox Building

3 Rue St. Georges, Paris.

North Attleboro.

H. U. Wilson, western representative of the Plainville Stock Co., was at the factory last week.

George Berthold has been admitted into the firm of P. J. Callowhill Co., which recently moved to Attleboro.

Hosmev F. Keeney has begun the manufacture of jewelry in the Royal Textile Co. building on Orne St.

A fire was averted in one of the "L's" of J. F. Sturdy & Sons' factory at Robinsonville on Tuesday by an employe.

Walter B. Ballou has declined a third term as a member of the Municipal Electric Light & Water Board.

Fred B. Brigham, of Cheever, Tweedy Co.; Frank Ruggles, of W. H. Bell & Co.; Thomas G. Frothingham and Walter Duncan, of C. Ray Randall & Co., returned from western trips last week.

Indictments were returned by the Bristol County Grand Jury, Thursday, upon two cases of importance to jewelers. Edward Trembley was charged with having stolen a chain from the estate of O. M. Draper and Frederick De Grenier was charged with breaking and entering the factory of Fred. S. Gilbert at night time and the larceny of buckles. The trials are on the calendar for this week.

The committee appointed at the last town meeting to investigate as to the feasibility of establishing an industrial school has decided to give an adverse report. This is due to the hostility displayed by the employes in the shops and because of the present industrial conditions. Fred A. Howard, of the Frank M. Whiting Co., will make the report to the citizens at a town meeting which will be held March 16.

The interest taken in the jewelry designing classes at the evening school has been, in the estimation of Superintendent of Schools Fuller, one of the encouraging features of the year. The attendants have been so enthusiastic and the results achieved so gratifying that it was decided by the School Board to continue the designing classes several weeks longer than the regular school. Therefore, while the evening school closed on Jan. 31, it will be Feb. 21 before the designing classes are finished. It is believed that these sessions three evenings a week will be eventually of material assistance to the manufacturers.

Charles G. Bancroft, receiver of the Jewelers' National Bank, last week issued a statement to depositors in which he intimates that a dividend will be paid. In a suit entered a few weeks ago by the receiver against Mrs. Marion N. Sargeant, of Auburndale, he alleged that the defendant received from her husband, Frederick F. Sargeant, late cashier of the Jewelers' National Bank, \$25,000, which rightfully belonged to the failed bank. Mr. Bancroft has entered an amendment in the Supreme Court, alleging that the amount is \$65,000 instead of \$25,000. The suit is pending in the Suffolk County Court. An official of the bank says that part of the securities reported to the Comptroller of Currency as worthless have been realized on. It is also given out that several thousand dollars have been got from the assets scheduled in the report as doubtful.

Boston.

C. F. Aldrich has been on a trip through Connecticut.

Howland Twombly has been appointed receiver in the bankruptcy case of A. A. Skinner.

C. W. Inslee, eastern sales manager, and B. L. Dunn, advertising manager, of the Oneida Community, Ltd., were in Boston last week.

Lawrence F. Percival, of D. C. Percival & Co., is on an outing trip to Jamaica. He will make a number of trips about the island in his automobile.

E. B. Cook, treasurer of the Woodman-Cook Co., was at the Boston office last week and reports business active enough to keep the factory at Portland, Me., running on full time.

The Smith-Stern Co., Lynn, Mass., to deal in jewelry, has been incorporated, with a capital of \$3,000. The officers are: President and treasurer, Lillie H. Smith; clerk, Benjamin F. Stearn, both of Lynn.

G. Willard Frost has bought the jewelry business of Nelson Bros., in Chelsea. Mr. Frost has been for a number of years with A. Paul & Co. James T. Nelson, whom he succeeds, retires from business on account of poor health.

The Sheffield Mfg. Co., of this city, to deal in silverware, has been incorporated, with a capital of \$30,000. The officers are: President, Charles H. Seavey, Jr., Watertown; treasurer, Paul Wolfkehl, Newton; clerk, Reuben S. Wyner, Roxbury.

The stock of Herbert L. Gruber, who was formerly in business in the Jewelers' building, was sold at auction by Henry M. Rich, Feb. 5, by order of the trustee, and brought somewhat more than was offered for it a short time ago in negotiations for a private sale.

Alex. P. Maynard and John A. Potter, of the Boylston St. firm of Maynard & Potter, sailed on the *Romanic*, Feb. 1, for the Mediterranean. They will visit the principal cities of Italy, Germany and France in quest of unique art and jewelry goods for their stock.

Buyers in town during the week included: Frank B. Howard, Rutland, Vt.; Percival H. Safford, Rochester; George H. Woodbury, Newport; Joseph Geoffrion, Manchester, N. H.; B. D. Loring, Plymouth; E. S. Clark, Sandwich; Frank Barrett, Hudson, Mass.; Samuel Aronson, New York.

John W. Wilson, of the Wilson Bros. Co., has been indicted by the Suffolk County Grand Jury on the larceny charge preferred against him by Treasurer Lombard, of the corporation, who alleges that Mr. Wilson is a party to the disappearance of a box containing \$4,000 from the safe of the store shortly after the holidays.

The Harry Eldredge Goodhue Co., of Cambridge, Mass., has been formed, with \$20,000 capital, to manufacture and sell stained glass windows, the organization being effected under the laws of Massachusetts. The directors are: Harry E. Goodhue, president; Walter G. Ball, treasurer, and George A. Osborne.

A very enjoyable dinner was spread last evening for a gathering of upward of 25 clerks from the jewelry establishment of

Shreve, Crump & Low Co. at one of the leading hotels. The after-dinner exercises were under the direction of R. Stanley Sanderson as toastmaster, who proved to be an unqualified success in that position, happily introducing the various participants to make a speech or contribute in some other entertaining manner to the pleasurable features of the occasion. There were musical numbers of much excellence, including some well rendered vocal solos by R. L. Harlow and R. G. Randall. Although the assemblage was composed of male employes only, the ladies were remembered with a toast to them at the close and the singing of "Good Night, Ladies," the company dispersing just before midnight. It was suggested and unanimously approved that the custom be adopted of having similar gatherings semi-annually. Much credit was given to W. S. Wittnauer for the success of the dinner, arrangements having been under his direction. Those present were: Gus. Henckle and William Kahle, guests, and R. Stanley Sanderson, Charles S. Patten, Waldo S. Green, Ralph L. Harlow, Frank Supple, Russell G. Randall, William T. Simpson, Julian Dunlop, Victor J. Hyde, William B. Morris, William J. Toppan, William S. Wittnauer, Lewis L. Knott, Fred Gowdy, Percival Nichols, Charles P. Fowler, Harold Dayton, F. V. Braun, Charles Walker, George Cath, Adolph Lins, Andrew F. Geddes, W. Kilb, Joseph D. Young, George Fleming, W. Armington, William Lee, William B. Morton

Canada Notes.

George E. Ellis, Winnipeg, Man., visited Toronto, Ont., last week.

The assets of the firm of Sloves & Cohen, Montreal, who recently assigned, are to be sold.

J. N. Brouillet, Montreal, has made an assignment with liabilities amounting to about \$4,000.

Wheatley Bros., Regina, Sask., have dissolved partnership, A. L. Wheatley continuing the business.

C. R. Sumner, London, Ont., and W. A. Smith, Oakville, Ont., called on the Toronto, Ont., trade last week.

W. K. George, of the Standard Silver Co., has been elected president of the Toronto Reform Association, Toronto, Ont.

The Dennison Mfg. Co. has removed its Canadian office from Montreal to the Traders' Bank building, Toronto, Ont., where it is comfortably situated.

R. J. Abbs, western traveling representative of the Goldsmiths Stock Co., Toronto, Ont., left, last week, on a trip to the Pacific coast.

The trade here is not disposed to attach any importance to sensational reports published in the local press as to a change in the price of diamonds. Harry Ryrie, of Ryrie Bros., Ltd., said: "We know nothing as yet to indicate any change in diamond conditions. As a matter of fact, there have been no diamond dealers from Europe offering goods here this year at any price. We are awaiting developments, but never in any season do we buy before April and expect to make our purchases as usual this year."

Lancaster, Pa.

Among the visitors to the local trade last week was Charles Church, a Chicago jobber.

Henry Sobel has been engaged to look after the numerous clocks in the *New Era* office.

E. R. Kant, of the Non-Retailing Co., has returned from a trip through West Virginia and Ohio.

Elbridge Wisner, a jeweler and diamond cutter, formerly with Ezra F. Bowman's Sons, has taken a position with John B. Roth, Jr.

The town clock on the Moravian Church at Litz has been doing faithful service for the past 100 years, and is still in perfect condition.

Oliver Mentzer, formerly foreman of the jewelry department of Ezra F. Bowman's Sons, has returned from North Carolina to resume his old position with that firm.

The following jewelers visited Lancaster last week: John L. Moser, Pueblo, Col.; Marcus B. Leeks, Charleston, S. C.; Paul S. Frey, Henry Lowden, Richmond, Va.

At a fair held last week by Lancaster Company, Ancient Order Knights of the Mystic Chain, a novelty feature was a jewelry table, in charge of David Waser and Miss Sarah Eckert.

Webb C. Ball, Cleveland, O., was the guest last week of Charles D. Rood, president of the Hamilton Watch Co. John C. Perry, superintendent of this factory, has started on an extended tour of their trade in the west.

James M. Eisaman, watchmaker for William Eidem, Greensburg, Pa., has entered the Ezra F. Bowman Technical School for a course in engraving. Benjamin H. Prowell, of Harrisburg, has left the school to take a position with J. O. Clawson, Brownsville, Pa.

H. F. Andrews, for many years the leading jeweler of Strasburg and vicinity, has decided to close out the business and give special attention to the optical business. His successor in the jewelry business will be H. Frank Musser, an employe of Mr. Andrews, who will open his store, April 1, in the room occupied by Jacob K. Andrews. The latter will remove to Christiana, Pa.

Pacific Coast Notes.

Max F. Noack, Santa Rosa, Cal., is now in the east.

A. B. Wilson, Martinez, Cal., has added J. A. Patterson to his force.

Edw. Praet, Woodland, Cal., has been seriously ill for the past week.

L. A. Scott was recently arrested in Yuma, Ariz., charged with a large diamond theft at Santa Rita, Cal. On searching him, the officers found 18 diamonds in the soles of Scott's shoes.

P. Savolainen & Bro., Virginia, Minn., have just moved into newly furnished quarters on Main St.

Arthur S. Ferris, South Norwalk, Conn., who is both a jeweler and safe expert, was called to New Canaan a few days ago to look over the post-office safe at that place, which was robbed a short time ago. He gave as his opinion that the thieves were amateurs.

ADDISON W. WOODHULL, President.
FRANK K. HUFF, Vice-President.

GILBERT T. WOODHULL, Treasurer.
WILLIAM J. McQUILLIN, Secretary.

MOUNT & WOODHULL,

IMPORTERS OF

DIAMONDS,

OTHER PRECIOUS STONES,

PEARLS, ETC.

MAKERS OF

FINE
DIAMOND
JEWELRY.

26 Maiden Lane,

(Southwest Corner Nassau Street)

NEW YORK

BAGG, PERINE & CO.
IMPORTERS
452 FIFTH AVENUE, at 40th Street
(Formerly at 21 MAIDEN LANE)
NEW YORK

CABLE ADDRESS:
MILBAGG

RUBIES AND
SAPPHIRES

EMERALDS, DIAMONDS
AND PEARLS

TELEPHONE
NUMBERS:
917-918 BRYANT

Pearl Necklaces and Collarettes.

Mounted
Diamond
Jewelry

of every
description.



Leading Names
Emil Krohn
John W. Rucker
Frank L. Wood

Largest
assortment
of all kinds of
very fine, fancy
and rare gems,
including Pearls,
Diamonds, Rubies,
Emeralds and Sapphires.

182 & 184 BROADWAY
NEW YORK

**Particularly Fancy
Colored and Fancy
Shaped Diamonds.**

Utica.

Evans & Sons, 32-34 Columbia St., at the annual meeting of stockholders, elected Thomas P. Evans as president; George H. Evans, vice-president; Charles T. Evans, secretary; Arthur D. Evans, treasurer and manager; W. MacDaniels and P. Erwin Cieppen, inspectors of election.

Appraisers have made an inventory of the bankrupt stock of George C. Smith, jeweler, in Watertown. The value of the stock in the store is placed at \$2,570 and other stock and fixtures are held by other parties as collateral security for loans. S. Silverman holds 23 rings valued at \$500. The one-third interest of Smith in the Watertown Jewelry Co. is placed at \$400, and there are accounts due valued at \$400. A trustee was appointed at the first meeting of creditors last week.

The Appellate Division of the Supreme Court, at Rochester, has decided a case which is of much interest here. A. J. Purvis, a local stationery and book dealer, made a contract with the Rhode Island Mfg. Co., of Iowa City, Ia., to act as the company's representative in Oneida County. Part of the deal was an understanding whereby Purvis was to advertise to give away gold rings to all babies under 12 months which were brought to the store. Purvis saw the possibilities of this advertising feature and ordered \$320 worth of jewelry, rings, watch fobs, stickpins and belt pins. Customers began to return the jewelry to Purvis within a week or so after purchased, claiming that what they bought for gold was really a cheap variety of plated ware. Purvis, upon the advice of his attorneys, shipped the jewelry back to Iowa City, but the Rhode Island Mfg. Co. refused to accept it and sued to recover the amount of the bill. The company's witnesses swore that some of the articles were worth \$2.50 a piece, while Purvis' witnesses testified that \$1.50 a dozen was a good price for them. The suit in County Court was decided in Purvis' favor, and now the Appellate Division has affirmed the judgment.

Minneapolis and St. Paul.

William Krohn, Annandale, Minn., was in Minneapolis on his way to Cuba, last week. Mr. Krohn last Winter visited Colorado.

The Blumencranz Jewelry Co., 231 Nicollet Ave., Minneapolis, will move into the store adjoining, at 235 Nicollet Ave., soon after March 1.

Both members of the firm of Perry & Mattson, new jewelers, of Eveleth, Minn., were in the Twin Cities, last week, upon their return from a visit to Chicago.

"The retail jewelry business," said a jeweler, "is escaping the excessive amount of cut price advertising which is marking nearly every other line of merchandise here. The merchants in clothing and other reasonable goods carried over a considerable amount of Winter stock and have been working hard to unload it. Whether the jewelers have been more fortunate in gauging the wants of their trade or regard it as useless to attempt to force trade, they have not been indulging in any such extensive price cutting."

Philadelphia.

Charles Kratz is preparing to open soon his new store in Souderton, Pa.

J. B. Bechtel, of Joseph B. Bechtel & Co., made a trip last week through the Schuylkill Valley.

Loms and Ed Sickles, of the firm of M. Sickles & Sons, returned from a visit made to New York last week on business.

Louis H. Scherr, engraver, has resigned his position with the Bailey, Banks & Biddle Co., to go with S. Kind & Son, 1110 Chestnut St.

The sympathy of the trade has been extended to Walter M. Engle, retailer, 4233 Lancaster Ave., on account of a death in his family last week.

C. Mitchler, watchmaker, has resigned his position with Peter Korn, Market St., near 9th St., and has opened a retail store of his own in Atlantic City.

Charles Schrisbaum, 2537 N. 18th St., was honored last week by being appointed by Judge Von Mosehizer as foreman of the February Grand Jury.

F. Samuels, watchmaker, last week, resigned his position with Lyons & Wilkinson, Lancaster Ave., to go with William Gibbons, 40th and Market Sts.

William Hueber, Elmer, N. J., has been in this city for several days at a time during the last fortnight, undergoing treatment for a serious stomach disorder.

S. H. Packard, watchmaker and salesman for R. L. Saunders, was transferred last week from the latter's uptown store to the central store at 8th and Market Sts.

B. Lieberman resigned his position last week with Ben Gebhard, 735 Sansom St., as jeweler and diamond setter, to start in business for himself. He has taken quarters at 709 Sansom St.

Robert King, 2419 Atlantic Ave., Atlantic City, sustained a double affliction last week when his wife and infant child died. The heartfelt sympathy of his friends in the trade here has been extended to him.

Henry Tiedemann, 19th and Washington Ave., has completed the contract of installing the new show cases and interior woodwork for the new jewelry department of the Penn Traffic Co.'s store at Johnstone, Pa.

Charged with the robbery of \$1,000 worth of jewelry from John Woodson, a colored jeweler, 1929 Filbert St., Dec. 18 last, while Woodson was traveling to New York, detectives have arrested William Jackson, a colored barber of New York, and he will be arraigned for trial this week.

William Todd, watchmaker for the trade, 711 Sansom St., sold out last week to George Kohler, 735 Sansom St. Mr. Todd has decided to retire from business and pass his remaining days quietly with his sons at Riverton, N. J. He has been in business in this city for many years and was known to nearly all watchmakers and jewelers.

The Hoover & Smith Co., 616 Chestnut St., was a victim, last week, of the sneak thief who has been stealing signs, door knobs and other metal fixtures from business houses in the central section of the city. The thief carefully unscrewed a costly sign and carried it off. His especial mania, however, is to make off with silver-plated

door knobs. The police have been unable to capture him.

Among the out-of-town retailers purchasing here during the week were: E. D. Waddell, Wildwood, N. J.; C. W. Laubenstein, Minersville, Pa.; M. E. Hunter, Beverly, N. J.; E. D. Oliver, Burlington, N. J.; John MacPherson, Mauch Chunk, Pa.; D. H. Kranse, North Wales, Pa.; S. L. Diehl, Penn Argyl, Pa.; J. Harry Halt, Mt. Holly, and Calvin Solliday, Lambertville, N. J.

Albert J. Gannon, a silversmith, 1004 Chestnut St., surprised his friends in the trade last week by having Mayor Reyburn marry him in his offices to Miss May Josephine Rahilly, of Newark, N. J. Mr. Gannon had not even told any of his employes and all were amazed when they learned of the wedding. Mr. and Mrs. Gannon left immediately for a honeymoon trip.

Morris Rosenbaum, a retail jeweler, 8th St., near Vine St., was too alert last week to have the old pennyweight game practised on him, and, when a colored man entered his store and after some parleying over gold wedding rings substituted a brass one for a gold one in the tray, Mr. Rosenbaum summoned a policeman, who captured the thief after a short chase and locked him up.

The store, which was for 31 years occupied by Charles H. Stockwell, 11 S. 9th St., has been rented by John N. Taylor, Jr., who was well known in the jewelry trade in New York and this city, and is now undergoing extensive alterations, which, when completed, will give Mr. Taylor one of the most attractive jewelry stores in this section of the city. Mr. Taylor is the son of John N. Taylor, formerly of Kremenetz & Co.

Friends in the trade of George W. Reimer, a retail jeweler and watchmaker, 5115 Germantown Ave., Germantown, learned last week with sincere regret of his commitment to the insane department of the Philadelphia Hospital. Mr. Reimer's mental affliction was brought about by overwork. For years he has applied himself night and day to his business, seldom taking time for rest or recreation and gradually but surely his devotion to work weakened him physically and finally affected his brain. The business is being carried on by Mrs. Reimer.

D. Laubach, watchmaker, formerly with F. S. Musselman, Bath, Pa., and who is well known to the trade here, purchased the stock, good will and fixtures of W. C. Geary, 7038 Woodland Ave., last week and immediately took charge of the store. It is in a new and rapidly growing section of the city, and Mr. Laubach expects a successful career. Mr. Geary was obliged to give up the store on account of ill-health and departed last week for Los Angeles with his wife and family, where he will make his home in the future and probably engage in the jewelry business there.

The Philadelphia Jewelers' Club held its annual meeting at the club rooms, Chestnut St., near 13th St., last night, after THE CIRCULAR-WEEKLY had gone to press. Col. J. Warner Hutchins, William H. Long and A. J. Le Jambre were unopposed for president, treasurer and secretary, respectively. The only contests were for election to the board of governors, five of whom are to be elected out of 15 candidates. After the meeting Col. Hutchins announced the appointment of the committee to have charge

of the dinner to be given at the Bellevue-Stratford Hotel on the evening of Feb. 22, the anniversary of the birth of Washington and of the reception committee to welcome the guests. A complete report of the meeting will be made in the next issue of THE CIRCULAR-WEEKLY. Announcement will be made about the latter part of the week of the list of notable men who will be the club's guests of honor.

Many retail jewelers, wholesalers, watchmakers and others in the trade here are joining heartily in a movement to have the next State Legislature repeal the obnoxious mercantile tax law by the provisions of which merchants are declared to pay taxes on the amount of business transacted and to open their books for the inspection of the authorized agents of the State. It is declared that abuses have crept in and that the application of the law is made to coerce merchants to support various political leaders. It will be recalled that the Bailey, Banks & Biddle Co. some years ago unsuccessfully contested the constitutionality of the law and carried the case to the Supreme Court of the State. The Business Association of Pennsylvania has been formed to effect the repeal of the law. Among those who have subscribed to the association are Col. J. Warner Hutchins, president of the Jewelers' Club; John F. Blisard, and Chas. H. O'Bryon.

Harrisburg, Pa.

TRADE CONDITIONS.

Jewelers are having a fair run of repair work during this usually dull month, and some of them have been pretty busy in this line. Sales of new goods are not keeping the clerks on the jump, but this condition of trade has been expected, so that none of the jewelers is disappointed. All of the craft in Harrisburg are looking forward to a better state of affairs next month, and to a fairly good Spring trade. The jewelers in Steelton and Middletown are being hit pretty hard because of the continued shut-down of many important industries.

M. Landis has opened a jewelry and general store in Shippensburg.

The Philadelphia and Reading Railway watch inspector paid his regular visit to this city last week.

The stock of Samuel Rosen, Northumberland, was sold by Receiver in Bankruptcy F. A. Witmer last week.

Mr. and Mrs. Henry Cluster assisted at the 20th anniversary celebration of the Ladies' Hebrew Social Circle at Chestnut St. Hall last week.

C. J. Hillard has exchanged his store at 28th and Main Sts. to Joseph Booser for two properties on Main St.

John and Samuel Bailey and Henry Patterson were convicted at Carlisle last week of robbing the store of A. C. Stamey in Leesburg, Nov. 27, of jewelry, etc.

Both Harrisburg and York are bidding for the location of the plant of the Southern Watch Case Mfg. Co., now located at Nashville, Tenn. President O. E. Bell, of the company, has been in both cities looking at available sites.

Robert H. Miller, alias Charles Higgins, who was taken to Altoona for trial after serving a sentence here for attempting to loot the store of G. A. Hutman, 1013 N. 3d St., has escaped from the county insane asylum, whither he had been sent.

WM S. HEDGES & CO.,

IMPORTERS AND CUTTERS OF

DIAMONDS.

Precious Stones and Pearls.

170 Broadway, Corner Maiden Lane, New York.

27 Holborn Viaduct, London.

R. C. SAUNDERS, Pres.

W. V. LAURINO, Vice-Pres.

JOSEPH P. MEURER, Treas.

SAUNDERS, MEURER & CO.

CUTTERS AND IMPORTERS OF **DIAMONDS** AND OTHER PRECIOUS STONES

FINE PEARLS AND FANCY GEMS

65 Nassau St., Cor. John St., Prescott Building Telephone, 1613 Cortland New York

Newark.

Sydney C. Straus, of Schulz & Co., has started on his regular western trip.

Schulz & Co. have decided to change their name to Layman & Straus Co., to take effect July 1, 1908. Sydney C. Straus and Percy M. Layman are now in sole control of the business.

Theodore M. Willis, one of the oldest jewelers in Montclair, N. J., is at the point of death at the Mountain Side Hospital where he is suffering from concussion of the brain, resulting from a fall on the ice Monday, while on his way to his home.

A lecture will be given by Prof. J. H. Monaghan before the Newark Manufacturing Jewelers' Association, March 14, at the lecture room of the Free Public Library. The lecture will be on the special application of technical and manual training as related to the jewelry craft.

The Crystaleth Mineral & Mining Co. has been incorporated under the laws of New Jersey, with a capital stock of \$250,000. The purpose of the company is to make artificial gems. Wm. Hill, Otto B. Reichelt, A. Aeshiman and Michael J. Quigley are the incorporators. The factory will be located in Newark.

The two thieves who entered the store of John Macher on Park Ave., East Rutherford, N. J., and took a tray of fountain pens and were later captured, have been sentenced to six months in the county jail at Hackensack. The men gave their names as Max Miller and J. L. Stevens. They were tried in Special Sessions and found guilty of larceny.

John H. Blackford, for 40 years an employe of Alling & Co., died at his home, 36 Bergen St., Feb. 3. The funeral was held Wednesday afternoon of last week from the Fairmont Baptist Church. Mr. Blackford was an active church worker and a member of the John Custer Council, No. 130, Jr. O. U. A. M. The deceased is survived by a widow, two sons, one daughter and a sister.

Titus Pantillon, 215 Mulberry St., was swindled out of about \$80 worth of jewelry Tuesday of last week by a man who came to his store and gave the name of Kausman. The visitor selected a diamond ring valued at \$18.50, a diamond set heart worth \$41, and a pin valued at \$22, and on departing asked the jeweler to bring the articles to his address. The jeweler delivered the goods and the customer, saying that he would show them to his wife, went down the back stairs and never came back.

Kent & Woodland, manufacturing jewelers, Richmond building, who recently bought out the interest of W. W. Carpenter in the firm of Theberath & Co., have incorporated the business under the old name, and will continue it at 13 and 15 Franklin St. S. B. Kent has been elected president of the corporation; J. Henry Theberath, vice-president, and A. Lynden Woodland, secretary and treasurer. Philip Rittersbaecher will be the superintendent of the factory, and the concern will continue to manufacture a full line of brooches, festoons, scarf pins and original jewelry. Kent & Woodland will be the selling agents for the concern in New York, while R. H. Schwarzkopf, of Schwarzkopf & Penniman, will be the selling agent on the Pacific coast.

Goodfriend Bros.
IMPORTERS OF **PEARLS**

Sapphires
Rubies
Opals
Emeralds

Aquamarines
Peridot
Gem Coral
Tourmalines

and OTHER
Precious and Imitation Stones

PEARL-OPAL-CORAL
& AGATE NECKLACES

PARIS:
10 Rue Cadet.
PROVIDENCE:
212 Union St.

9-11-13
**Maiden Lane
NEW YORK**

Geo. Brunswick, N.Y.

The central diagram is a circular arrangement of gemstones with labels: AGATE, EMERALD, OPAL, CATSEYE, BERYL, PERIDOT, TOURMALINE, RUBY, SPINEL, GARNET, PEARL, ALMANDINE, SAPPHIRE, MOONSTONE, JACINTH, OLIVINE, ESSONITE. It also includes the text 'COPYRIGHT 1895 BY G. GOODFRIEND BROS.' and 'GEO. BRUNSWICK, N.Y.' at the bottom.

Pittsburg.

F. W. Johnston and wife, Garrettsville, O., were in Pittsburg, last week, on a shopping tour.

George W. White, of West, White & Christy, has been made a member of the Annexation Association of Bellevue, which desires to annex that borough to Pittsburg.

Among the out-of-town jewelers in Pittsburg last week were the following: H. B. Pothoff, Latrobe; J. F. Murphy, Dawson; B. E. Brown, Donora; W. H. Bowser, Ford City.

A. B. Regnier, Marietta, O., has written to friends here that he intends to dispose of his business because of ill health. He is looking for a buyer and expects to sell his place shortly.

The stock of Samuel Lippard, bankrupt, whose place of business is in Wylie Ave. was to have been sold at public auction last Friday, but the sale was postponed. Alpern & Seder are the attorneys for the receiver.

William H. King, Island Ave., McKees Rocks, Pa., and Belle D. Rigler, Burgetts-town, will be married to-day at the home of the bride's parents. Mr. and Mrs. King will take a southern trip and will be gone for several weeks.

C. S. Rehr, of the Marsh, Brown & Mather Co., is seriously ill with Bright's disease. John Pollack, formerly with the John M. Roberts & Sons Co., has accepted a position with the Marsh, Brown & Mather Co., taking Mr. Rehr's place.

The retail jewelers are organizing a duck-ping league of three-men teams. The following firms will probably be represented: W. W. Wattles & Sons, E. P. Roberts & Sons, Hardy & Hayes Co., J. C. Grogan, L. W. Vilsack & Co. and J. R. Reed & Co.

Michael Bass, a watchmaker employed by S. Mohr, of the Seventh Ave. Hotel block, Liberty Ave., was last week convicted in the Criminal Court of the larceny of some watchmaking material from his employer. Bass will be called for sentence in a few days. Mr. Mohr prosecuted the case.

The Pittsburg Chamber of Commerce will give a banquet to-night at the Hotel Schenley, in honor of the birth of Abraham Lincoln, and many jewelers will be present. Among those who will respond to toasts is Senator Philander C. Knox, whose subject will be "Our Commercial Future."

No trace of John Collins, who robbed S. C. Vorhees, a traveling salesman for West, White & Christy, of about \$5,000 worth of jewelry, at a Canton (O.) hotel, of which Collins was the porter, has been found. The robbery has put the firm to no end of trouble and days have been spent in checking up the numbers of the missing watches.

Henry Wilkins & Co., who have been doing business at 440 Wood St. for the past two or three years, have decided to give up their present quarters, and have leased space on the third floor of the Pittsburg Life Insurance building, Liberty and Sixth Aves. Several other jewelers are located in this building. The high rents in the downtown district are causing many jewelers to seek new locations.

A fire which broke out in E. Railroad St., Verona, last week, caused F. P. King, a

jeweler of that place, most serious alarm. His home is adjacent to that of the furniture establishment which burned to the ground. Mr. King's wife has been ill in bed, and so alarmed did members of the family become that it was necessary to carry Mrs. King from her room to a nearby residence. She is now suffering greatly from shock.

L. J. Vilsack & Co., who have given up their quarters in the Farmers' Deposit National Bank building, have not as yet secured a suitable location, but expect to secure quarters in a few days. Mr. Vilsack, who is one of the heirs to his father's fortune, it is now said, will receive about \$350,000 as his portion of the estate. Mr. Vilsack and his family returned last week from Cambridge Springs, where they had been resting.

Howard Colvin Eggers, who for the last 15 years had been identified with the house of E. P. Roberts & Sons, and one of the best known jewelry salesmen in Pittsburg, died last Tuesday afternoon at his home in Bellevue of a complication of diseases. He was 39 years old and the son of Frederick H. Eggers, formerly a prominent druggist of Pittsburg. Mr. Eggers had been in poor health for a number of years. He was educated in the public schools and studied art in the Julien Academy of Schools and Fine Arts at Paris, intending to devote his life to designing. Through his long stay abroad, Mr. Eggers became an accomplished linguist, being as familiar with the French language as with his own. Mr. Eggers was a devoted churchman, being a member of the vestry of the Grace Lutheran Church, Troy Hill, and a director of the Lutheran Theological Seminary at Gettysburg. He is survived by his mother, three brothers and four sisters. The funeral services were held from the family residence last Friday afternoon, and were well attended by members of the trade and friends. The interment was made in the family plot in the Allegheny Cemetery.

Connecticut.

G. P. Ittig has assigned to the E. H. H. Smith Silver Co., Bridgeport, a new design for a handle for spoons, forks and similar articles.

The Jennings Bros. Mfg. Co., Bridgeport, has filed with the Board of Relief a petition asking for a reduction of assessments on its investment in mechanical operations.

A patent has been granted to E. E. Stockton and A. H. Porter on a novel alarm clock. The inventors have assigned the clock to the E. Ingraham Co., Bristol.

President N. Burton Rogers, of the Connecticut McKinley Club, presided at the club's annual banquet, held in Danbury, last Wednesday. About 150 guests were present.

Chas. H. Northnagle, for many years employed as a chaser at the Meriden Britannia Co.'s factory, in Meriden, with his wife, Feb. 10, celebrated the golden anniversary of their wedding.

Inventory of the estate of the late Frank Hettich, New Haven, who died a few months ago, shows that the deceased had property valued at \$16,417, of which \$5,000 consists of real estate. The appraisers are John Gundee and James J. Lawton.

A. H. Breggin, a jeweler located at 23 Broadway, New Haven, last week, reported to the detective bureau that he had been defrauded by two shrewd strangers by means of the much-talked-of short change fraud. The amount involved was \$10.

S. W. Tasch, Danbury, recently supplied the handsome silver trophy to the Bloodhound Club of America, which will award it for the best pair of bloodhounds shown at the Westminster Kennel Club's show, to be held in Madison Square Garden, next month.

The general meeting of the stockholders of the J. D. Bergen Co. was held in Meriden Feb. 5, when the following officers were chosen: President and treasurer, W. H. Bradley; secretary, C. E. Stockder. The new directors are: W. H. Bradley, R. K. Keller, C. E. Stockder, C. D. Peets and W. H. Pooley.

The Waterbury Clock Co.'s Employees Aid Association, Waterbury, on Friday evening, Feb. 7, celebrated its 25th anniversary. During the 25 years the organization has paid out \$30,000 for sick benefits. It started with a membership of 52 and was assessed as high as 55 cents per week. The membership at one time dropped to 22, but at the present time it numbers 720.

Among those who attended the 13th annual banquet of the New Haven Business Men's Association, in New Haven, were: President F. E. Harvey, Hartford Business Men's Association; Mr. Lewis, of Hartford; President Lee Roberts, of the Bristol Business Men's Association; C. M. Parker, and Samuel H. Kirby, New Haven. Mr. Kirby was a member of the banquet committee designated as the "real toilers" on the banquet menu card.

The annual meeting of the New England Watch Co. was held in Waterbury Thursday and the following officers were elected: President, George L. White; vice-president, Edward L. Frisbie, Jr.; secretary and treasurer, William H. White; directors, George L. White, Edward L. Frisbie, Jr., James S. Elton, Henry L. Wade, Otis F. Northrop,

Importations at the Port of New York.

Weeks Ended Feb. 2, 1907, and Feb. 1, 1908.		
	1907.	1908.
China, Glass and Earthen Ware:	1907.	1908.
China	\$107,889	\$91,390
Earthen ware	10,560	13,520
Glass ware	47,514	33,178
Glass, optical	109	3,032
Instruments:		
Musical	15,418	9,314
Optical	9,226	2,859
Philosophical	9,582	1,411
Jewelry, etc.:		
Jewelry	14,180	17,327
Precious stones	767,274	153,070
Watches	29,142	11,663
Metals, etc.:		
Bronzes	1,194	363
Cutlery	30,589	21,731
Dutch metal	5,597	6,921
Platina	109,397	35,661
Plated ware
Silverware	475	354
Miscellaneous:		
Alabaster ornaments	124	4
Amber	11,209	92
Beads	3,395	5,031
Clocks	8,403	2,202
Fans	7,082	6,278
Fancy goods	7,953	5,209
Ivory	36,628
Ivory, manufactures of...	791	132
Marble, manufactures of.	4,333	27,835
Statuary	4,449	8,944

BLACK OPALS

REMARKABLE :: IRIDESCENT :: BEAUTIFUL

Black Opal, a recent Australian discovery, is one of the most beautiful stones hitherto found.

With its many inimitable jewelry creations are possible that must appeal in a forceful manner to the trade.

These remarkable stones exhibit a wonderful play of brilliant colors, ranging from light to cobalt blue, with flashes of violet, from delicate shades of green to peacock green, and all shades of reds, merging into orange and yellow tints.

Black Opal is a worthy addition to the finest stock, and jewelers will find it a welcome "Trade Magnet."

We can furnish these stones in various sizes and shapes, and their full merits can only be appreciated by being seen.

We make a specialty of AUSTRALIAN and MEXICAN OPAL MATRIX.

BUY FROM THE CUTTERS

AMERICAN GEM & PEARL COMPANY

14 & 16 CHURCH STREET, NEW YORK

London, 16 Holborn Viaduct

Paris, 39 Rue de Chateaudun

FROM MINES TO MARKET

STERN BROS. & CO.,

CUTTERS OF

DIAMONDS,

CUTTING WORKS:

138-142 West 14th St., N. Y.

68 Nassau St.,

NEW YORK.

CHICAGO,
103 State Street.

LONDON,
29 Ely Place.

A. ROSEMAN, 9-11-13 Maiden Lane, New York

IMPORTER OF

DIAMONDS

Maker of Diamond Jewelry



TRADE-MARK.

Established 1872

HEADQUARTERS FOR

AMERICAN WATCHES

J. Hobart Bronson, Gilman C. Hill, G. W. Burnham, John Booth Burrall and William H. White, Secretary White, after the meeting, said the factory would continue to run 40 hours a week, the schedule which it is now on.

A meeting of the creditors of S. Hart, Waterbury, was scheduled to be held at the Everett House, New York, yesterday, Feb. 11, at 2 P. M.

Owing to a serious break in the city's water main and the flooding of houses and stores thereby, arrangements were made by the mayor with the officials of the international Silver Co. for the opening of the factory reservoir at Main and Broad Sts., Meriden, by which the supply will be turned into the city pipes. President Geo. H. Wilcox, of the International Silver Co., and C. F. Lindsey, of the Bradley & Hubbard Mfg. Co., also agreed to help out the city in the matter. By this action water will be distributed to all parts of the city except to the higher points and the east side section of the city.

The Holmes & Edwards Mutual Relief Association, of the Holmes & Edwards Silver Co., Bridgeport, held its annual meeting recently in Pioneer Hall, after which an entertainment was given. The secretary's report showed that there was \$1,536 in the treasury at the present time. The election of officers resulted as follows: President, John W. Smith (M. J. Lynch having declined a re-election); vice-president, W. T. Clarke; secretary, A. J. Wilson; treasurer, H. S. Begley; auditors, George Guggenheim and R. W. Parry. A vote of thanks was given to the retiring president for his efficient services rendered during the past year.

Charles D. Davis, secretary of the Jewelers' Corporation, which owns the building at the southeast corner of Main and Wall Sts., Bridgeport, together with other property owners on Main St., since the assessments on buildings were raised last year and later reduced by the Board of Relief, are again complaining of the valuations put upon their holdings. Mr. Davis said he would take the matter before the mayor. He estimated the value of the land and building as \$88,483, which the Board of Assessors, it is alleged, raised to \$115,291. A member of the Board of Assessors said that the records at the town clerk's office shows that there is a mortgage on the property in question in favor of the People's Savings Bank for \$75,000, under date of June 28, 1906, and that a second mortgage for \$12,000 is held by Frederick B. Hawley. The law provides that the banks shall not accept mortgages beyond 50 per cent. of the value of the real estate and, by taking the first mortgage only, the assessors say, that the bank in question evidently values the land at \$150,000.

Wm. F. Foley was recently arrested in Walla Walla, Wash., following a description given by K. Falkenburg, a jeweler, located in the Die Bruke building, who had been defrauded to the extent of \$148 by a spurious check drawn on a Salt Lake City banking house. The arrest was made on receipt of a telegram from McCormick & Co., of Salt Lake City, stating that Foley had no funds there and that other papers had been received and returned.

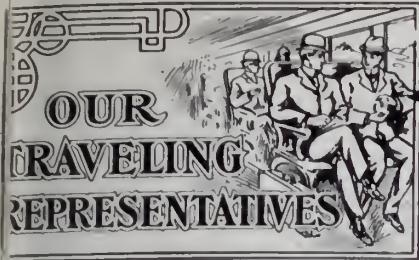

Myers, of R. & I. Myers, San Francisco, Cal., just returned from Eureka, Cal.

E. Mitchell, with M. Schussler & Co., San Francisco, Cal., will start south in a few days.

Leon Price, with H. A. Forbes, Pacific coast representative of the Duober-Hampden Watch Works, will start on the road this week.

Lorace Bardwell, with J. B. Whitney & Co., San Francisco, Cal., has just returned from a trip through the territory north of San Francisco Bay.

Valter Marble, of the W. B. Marble Co., has just returned from San Francisco, Cal., for the South Sea Islands.

Here he expects to join Jack London, the popular novelist, in his trip around the world in a boat.

Ernest Arnold, formerly of the city force of A. I. H. & Son, San Francisco, Cal., has started for the northwest with the company's lines of clocks and silverware.

The traveling representatives in Denver, Colo., last week, included: J. Rothschild, Kauffman, Rothschild & Co.; A. C. Hall, Holmes & Edwards; J. C. Co.; Mr. Merton, Henry G. Lafort & Co.

Travelers of D. C. Percival & Co., Boston, Mass., most of whom have been retained at the Boston headquarters throughout the past month, started this week again on their trip with Springfield, Mass.

Among the traveling representatives who, recently, visited San Francisco, Cal., were: Mr. Newberger, Keller & Co.; Mr. Sandfelder, D. F. Briggs & Co.; Mr. Metcalf, Plainville Stock Co.; Mr. Torrey, Leys-Christy Co.

The following traveling representatives called the trade in Kansas City, Mo., last week: J. Decker, Plainville Stock Co.; John A. Davis, J. C. Rogers Mfg. Co.; I. Price, Louis Strasser's Son & Co.; E. P. Tiffany, F. H. Sadler & Co.; K. D. Yeaton, S. Sternau & Co.

Traveling representatives in Omaha, Nebr., last week, included: George D. Laurence, Reed & Barstow, F. L. Pettie, Waterbury Clock Co.; R. D. Mundy, Mauser Mfg. Co.; Mr. Hartshorn, Krenz & Co.; A. S. Riley, Mandeville, Carrow & Co.; George Beardsley, Allsopp & Allsopp; Fred. Wilkinson, Longines Watch Co.; John Lassau, rtin-Copeland Co.

Among the traveling representatives who visited Indianapolis, Ind., last week, were: Carl F. Haaber, Wm. Mfg. Co.; A. S. Wormwood, Illinois Watch Co.; and Joseph Fahys & Co.; Robert Edwards, Niting Mfg. Co.; D. A. Burt, R. Wallace & Sons Co.; H. E. Vincent, International Silver Co.; J. Cahn, Borrelli & Vitelli; George A. Bain, Wilcox Silver Plate Co.; Charles H. Ide, Farringham Mfg. Co.; Charles E. Eckel, Unger Bros.; H. Hauk, Frank H. Mooney & Co.

Traveling salesmen visiting Boston, Mass., during the week, included: Frank Keller, Keller Mfg. Co.; Cyrus Price; William H. Fowlie, Elgin National Watch Co.; H. Frank Thompson, Pairpoint Mfg. Co.; William C. Burwell, Mauser Mfg. Co.; Frank Trewin, Keystone Watch Case Co.; Charles Power; Louis Glick, Hammel, Riglander & Co.; J. Gesswein, Wm. Dixon, Inc.; Mr. Cobb, W. Cobb & Co.; Mr. Drown, Ostby & Barton Co.

The following traveling representatives visited the city in Lancaster, Pa., recently: W. S. Gardner, Sisseton Jewelry Co.; F. A. Brennan, L. Witsenhausen; M. Bauman, M. Bauman & Co.; Wm. H. Ward, R. M. Justice; Henry Hoffa, Hodenpyl Walker; F. Dilsheimer, Ferd. Dilsheimer & Co.; Wm. C. May, Moskowitz Bros.; George S. Ivellie, D. Wilcox & Co.; Charles F. Brinck, Crescent Watch Case Co.; W. T. Francis, Waterbury Clock Co.; M. Adels, M. Adels & Co.; F. N. Olinda, New England Watch Co.; Mr. Claxton, Dennison Mfg. Co.

Traveling representatives who called on the Cincinnati, O., trade, during the past week, included: J. Powell, S. O. Bigney & Co.; Otto Sinnauer, Penheimer Bros. & Veith; Eli Howitz, Arnstein & Co.; Jack Thompson, J. B. Bowden & Co.; George A. Allsopp, Jr., Allsopp Bros.; George W. Arney, Allsopp & Allsopp; John J. Moffitt, Taylor & Co.; W. H. Gregory, Strohbell & Crane; F. Gibson, Gibson, Krugler Co.; C. L. Krugler,

Mandeville, Carrow & Crane; Julius Wodiska; A. B. Randall, Coddling & Heilhorn Co.; Emil Pick, Hammel, Riglander & Co.; M. J. Lampert, Henry Zimmern; W. A. Moore, William Dixon, Inc.; F. A. Perry, John Russell Cutlery Co.; Ralph M. Sawyer, Shafer & Douglas; Geo. W. Whittemore, Sessions Clock Co.; J. W. McClannin, Wilcox Silver Plate Co.; Mr. Schwenn, Sohn & Hyman; Frank L. Wood, Ludwig Nissen & Co.; Alfred Kent, Jacob Weintraub.

Recent Decisions by Board of General Appraisers on Jewelry and Kindred Lines.

Decisions by the Board of United States General Appraisers in cases involving the duty on jewelry and kindred lines have been announced in the last week as follows:

ORNAMENTS—PINS—JEWELRY.—Protests of Bloomingdale Bros. *et al.* Certain ornaments classified as jewelry were claimed to be dutiable as manufactures of the component of chief value. This contention was sustained as to a portion of the goods. Note G. A. 6374 (T. D. 27382), G. A. 6376 (T. D. 27390), and G. A. 6658 (T. D. 28391).

SHELL CAMEOS.—Protest of Benedict & Warner. Unmounted cameos classified as manufactures of shell under Par. 450, Tariff Act of 1897, were claimed to be dutiable under Par. 135, relating to precious stones. Assessment affirmed. G. A. 5763 (T. D. 25512) followed.

VINAIGRETTES—JEWELRY.—Protest of Royal Metal Mfg. Co. Small gilt metal bottles with a ring attached for suspension purposes, which are generally used as vinaigrettes and which were classified as jewelry, were held dutiable as manufactures of metal as claimed by the importers.

ORNAMENTS—IMITATION PRECIOUS STONES—WAX BEADS.—Protests of Cohn & Rosenberger and protests of Albert Lorseh & Co. The protests were sustained as to certain ornaments, imitation precious stones and wax beads. G. A. 6374 (T. D. 27382), G. A. 6155 (T. D. 26723), G. A. 6342 (T. D. 27292), and G. A. 6639 (T. D. 28297) followed.

JEWELRY.—Protest of H. B. Claffin Co., protest of P. H. Petry & Co., protest of Stern Bros., protests of G. Hirsch's Sons *et al.* (New York). The articles were held to have been properly classified as jewelry. Note G. A. 6376 (T. D. 27390).

Death of William Van Keuren.

POUGHKEEPSIE, N. Y., Feb. 5.—William H. Van Keuren, one of Poughkeepsie's oldest and best known citizens and business men, died at his home in this city early Friday morning. For some time Mr. Van Keuren had suffered from a general breakdown and had sought health at Asbury Park, Atlantic City and elsewhere, but without avail. Not long ago he retired from the jewelry business in hope of regaining his lost health.

Mr. Van Keuren was born on Union St. He learned the jeweler's trade in his youth and in 1858 began business for himself. The business was started in connection with his brother as Van Keuren Bros., and in 1891 his brother retired, from which time he continued business alone.

Mr. Van Keuren was a son of John and Jane Van Keuren and the last of six sons, all of whom grew to manhood. He is survived by two sisters, Mrs. Mary Freeman, of Poughkeepsie, and Mrs. Kate Sloan, of

Syracuse. The deceased was a prominent member of the First Congregational Church and was an official.

Look Out for This Man Who Tries to Pass Worthless Checks.

Jewelers in New York and throughout the country are warned against a man who is trying to pass bogus checks on jewelers in New York City. The man visited several jewelers in New York, Monday, and tried to pass several checks, but, as yet, so far as is known, he has been unsuccessful.

He is wanted at police headquarters in New York, and detectives are trying to locate him. The man is known as Albert S. Wood, alias Captain Wood, and has served sentences in several parts of the country.

The swindler is described as slightly over six feet high, gray hair, and aged 71 years. His teeth are nearly all out, and he has a high color. He weighs about 139 lbs., and is of slender build. He has a wart on his nose and his face is wrinkled with age.

Be Careful in Dealing With This Jewelry Case Repairer.

The jewelers of New York and vicinity are warned by the Dennison Mfg. Co. to be careful in dealing with a man named Richmond, who is soliciting jewelry cases for repair on the strength of a former connection with the Dennison house, and saying that he has been authorized by members of the house to do work of this character.

The man about whom several inquiries have been made to the Dennison concern has never been connected with that corporation either at the factory or at the selling agencies, and no one connected with the concern has authorized him to use its name or solicit work of this kind. A man of this name solicited orders in Natick, Mass., a year ago, on similar representations, and in certain instances obtained cases to be repaired which he never returned.

A man named Richmond on similar representations obtained employment from B. Ash, 1165 Broadway, Brooklyn, last week, at lining trays. After working for three or four days, he was sent out to buy some cloth and did not return, or send the cloth or account for the money that was given him.

The man who worked for Mr. Ash is about 45 years old, five feet four inches high and weighs about 118 pounds. He has grayish hair and a red nose. He dresses shabbily, but is a good and quick workman, and said that he had been with the Dennison concern for about 38 years.

Thus far, no tangible clue has been obtained to the burglars who recently entered the jewelry store of O. T. Davis, Ault, Colo., and escaped with about \$2,000 worth of miscellaneous jewelry. Shortly after the robbery three men were seen boarding a southbound freight train.

A defective pipe attached to a furnace in the cellar under the store of the A. K. Jobe Jewelry Co., Jackson, Tenn., led a pedestrian to believe that the establishment was on fire, one day last week, and the fire department was summoned. Most of the jewelry was stored in safes so that there was little or no damage done by the smoke.

EICHBERG & CO.,

IMPORTERS AND CUTTERS OF

DIAMONDS,

65 NASSAU STREET,

(Prescott Building.)

NEW YORK.

DIAMONDS

TRY US ON

Lissauer & Company

52-54
Malden Lane
NEW YORK

HIMALAYA MINING COMPANY

MINERS AND CUTTERS OF

PRECIOUS AND SEMI-PRECIOUS STONES

537 FIFTH AVENUE

NEW YORK

LONDON
PARIS

OBERSTEIN
PROVIDENCE

LOUIS FELDENHEIMER

Importer and Cutter of

PRECIOUS STONES AND PEARLS

41 MAIDEN LANE

NEW YORK

ARTHUR REICHMAN

BUYS AND SELLS

AMERICAN BAROQUE PEARLS

65 Nassau St.

New York

SOHN and HYMAN

IMPORTERS of PRECIOUS and IMITATION STONES

Crystals Engraved and Painted from Photo. Crests and Coats of Arms Engraved.
Stone Seal Engravers and Incrusters. Lapidary Work a Specialty.

JOBGING STONES A SPECIALTY

47 and 49 Maiden Lane

NEW YORK

William G. Morstrom & Co.

DIAMOND IMPORTERS and MANUFACTURING JEWELERS

Memorandum Packages of Loose or Mounted Stones on request. We solicit Special Order Work.

78-80 STATE STREET

CHICAGO, ILL.

Buffalo, N. Y.

Herman Boasberg, of H. & J. Boasberg, 384 Main St., is in New York.

Ben. Henschel, of Heintz Bros., starts on his regular trip through the south this week.

The Niagara Ring Co. expect soon to occupy its new quarters, the location to be announced later.

Elmer Wood, of C. F. Wood & Co., New York, was welcomed by local friends during the week.

Joe Freedman, and son Lawrence, of Freedman Bros., are both hustling for business through Pennsylvania and Ohio.

The Prince Jewelry Co. has taken part of a store occupied by the Regal Shoe Co. and stocked it with a line of jewelry.

E. P. Burckhalter, superintendent of King & Eisele's factory, has been confined to his home with a bad case of blood poisoning caused from irritating a pimple on his hand.

Meyer Brown, 136 Seneca St., is around and attending to business again, after his unfortunate accident two months ago, when he fell down an elevator shaft and was seriously injured.

J. P. Simcox, for several years with T. C. Tanke, 378 Main St., in charge of the optical department, has organized a company and entered into new quarters in the German-American Bank building. Mr. Simcox is the president, and is in active charge.

J. K. Thompson, buyer for King & Eisele, has left on a special trip through New York and Pennsylvania. Mr. Randecker, the regular representative in this territory, leaves early in the week, as does Ford Crown, their middle west man. Mr. Goodfellow, their western salesman, is on his way to the coast. Phillip DeWein, for many years assistant of Mr. Kreuz, in the material department of this house, has been promoted to the traveling force, taking the place left vacant by the resignation of Harry Hobbs.

Washington, D. C.

The will of the late Norman Galt was filed for probate early last week, and devises the entire estate to the widow of the deceased, Mrs. Edith Bolling Galt, who was appointed executrix without bond. The will bears the date of Sept. 29, 1898.

Robert Castelberg, formerly manager of the local store of the Castelberg National Jewelry Co., who mysteriously disappeared from Washington in August, 1905, has brought an action through his wife, Mrs. Edna Castelberg, as his agent and attorney, against Joseph and Jacob Castelberg, trading as J. Castelberg & Sons and the Castelberg's National Jewelry Co., asking an accounting. The complaint which was filed in the District Supreme Court says that the plaintiff was a partner in the business until 1905, when he withdrew. He says there were uncollected accounts of which he was to receive one-half, and claims he has failed to receive anything on these accounts. He asks the court to direct an accounting. Castelberg was last heard of a year ago, when he was recognized in China by a reporter of a local paper.

Indictments Found Against Conrad Schickerling Growing Out of Old Charges.

Four indictments were handed down last week by the Grand Jury in New York against Conrad Schickerling, charging him with grand larceny on four counts—one for the larceny of diamonds from Henry E. Oppenheimer & Co., valued at about \$10,000, and the other three for the larceny of three separate lots of jewelry from Edelhoff Bros. & Co., valued in all at about \$15,000 to \$20,000.

The tangled affairs of Schickerling Bros. & Co. and Edelhoff Bros. & Co., have made the matter a difficult one to handle, but C. S. Mackenzie, attorney for the creditors, formulated the charge. It will be remembered that bankruptcy proceedings were begun against Schickerling Bros. & Co., in February, 1906, and that Conrad Schickerling, who was president of Schickerling Bros. & Co., was arrested in June, 1906, on a warrant obtained by Gustave A. Edelhoff, the president of Edelhoff Bros. & Co., 574 Fifth Ave., who were also put into bankruptcy. The warrant charged that the defendant converted a quantity of diamonds valued at \$6,000 that were entrusted to him on memorandum.

Several examinations of Mr. Schickerling were held at various times before Magistrate Whitman, and delays occurred which prevented an indictment, but Mr. Mackenzie at last succeeded in getting the case before the Grand Jury. A motion was made by Mr. Schickerling, asking for a discharge, but this was denied and he was held.

Mr. Schickerling frequently denied all the charges against him as far as they involved any criminal conduct. In the case of the Oppenheimer diamonds he denied that the transaction was of a memorandum character. According to his statement, the diamonds were sold to him the same as other stock. Mr. Schickerling claimed that he turned over two-thirds of the money obtained from the pawnbroker to the Edelhoffs for use in their business, retaining one-third for use in his own business.

Treasurer of the Hahn-Butler Co., Lincoln, Nebr., Asks Appointment of a Receiver.

LINCOLN, Nebr., Feb. 5.—Application was made last week to the district court by Elmer E. Meredith for the appointment of a receiver for the Hahn-Butler Co., of this city. Mr. Meredith is the treasurer of the company and, in his petition, states that he is the owner of 100 shares of the stock of the par value of \$100.

The Hahn-Butler Co. has for the past two years been engaged in the jobbing of jewelry, combs, leather and fabric belts, bags, purses, etc., and has a capital stock of \$25,000. Mr. Meredith alleges that the business has always been run at a loss and that during the past year it decreased and ran down until the company became insolvent and unable to pay its obligations. To attempt to further carry it along would be but to make matters worse and the court is therefore asked to appoint a receiver to wind matters up.

It is alleged that the obligations of the company amount to between \$9,000 and \$10,000, while the assets are worth from \$8,000 to \$9,000.

Games Rolled by the Jewelers' Bowling League of New York.

The following were the scores of the teams of the Jewelers' Bowling League in the games rolled last week:

Feb. 3.—Cooper Diamond Co.....	969	946	835
vs. Jos. Fahys & Co.....	856	827	837
Feb. 4.—H. W. Wheeler & Co.....	745	815	806
vs. Julius King Optical Co.....	683	666	855
Feb. 5.—Tiffany & Co.....	807	866	855
vs. N. H. White & Co.....	882	862	922
Feb. 6.—L. E. Waterman Co.....	742	815	696
vs. A. A. Webster & Co.....	830	719	789
Feb. 7.—Cross & Bequelm.....	949	937	912
vs. Cooper Diamond Co.....	917	839	1022

STANDING OF TEAMS.
Standing of teams in Jewelers' League, up to and including Feb. 7:

	Won.	Last.	High score.	Per cent.
N. H. White & Co.....	31	11	1,014	.738
Cross & Bequelm.....	29	13	1,017	.690
Cooper Diamond Co.....	31	14	1,022	.688
C. F. Wood & Co.....	24	12	943	.666
Tiffany & Co.....	27	15	969	.643
Aikin-Lambert Co.....	23	22	967	.511
Jos. Fahys & Co.....	23	22	906	.511
A. A. Webster & Co.....	16	29	916	.355
H. W. Wheeler & Co.....	10	26	922	.277
Julius King Optical Co.....	10	35	889	.222
L. E. Waterman Co.....	7	32	852	.179
Individual Averages (E. Roll, 197 21/42; Platt Adams, 190 11 39; E. E. Wood, 187 27; F. Schneider, 186 32 39; W. G. Wood, 186 14 33; W. C. Weber, 183 15 44; E. G. Howell, 182 30/45; R. H. Woodrow, 180 35 42.				

Attachment for \$6,000 Filed Against Jos. H. Crandall, Los Angeles, Cal.

LOS ANGELES, Feb. 5.—An attachment has been filed against Joseph H. Crandall, of this city, for \$6,000. Mr. Crandall, who conducts a store at 508 S. Main St., is about 40 years of age and has been engaged in business here for three years. He succeeded Lee Bros., in whose employ he had previously been for some time.

Prior to coming to Los Angeles, Mr. Crandall resided in Massachusetts. He has always borne a good reputation and his present reverses are said to be attributable entirely to unfavorab'e business conditions.

Jewelers' Gold Bars Withdrawn and Exchanged at New York.

Week Ended Feb. 8, 1908.
The U. S. Assay Office reports:
Gold bars exchanged for gold coin.....\$253,109.39
Gold bars paid depositors..... 57,270.69

Total	\$310,380.08
Of this the gold bars exchanged for gold coin are reported as follows:	
Feb. 3.....	\$56,618.08
" 4.....	25,853.16
" 5.....	66,551.17
" 6.....	47,093.33
" 7.....	25,968.99
" 8.....	31,024.66
Total	\$253,109.39

Market Price for Silver Bars.

The following are the quotations of silver bars in London and New York, as reported by Zimmermann & Forshay:

	London.	New York.
		.999 Basis.
Feb. 4.....	25 5-8d.	\$.57 1/2
" 5.....	25 1-2d.	.57 1/4
" 6.....	25 9-16d.	.57 3/8
" 7.....	25 13-16d.	.57 7/8
" 8.....	26 1-8d.	.58 1/2
" 10.....	26 5-8d.	.58 3/4

Thief Steals Rings Valued at \$500 from Brooklyn, N. Y., Jewelers.

A man who gave the name of J. H. Horton visited the store of L. Simon, 525 Fulton St., Brooklyn, Saturday evening, and made away with two rings valued at \$500.

Speaking of the matter to a CIRCULAR-WEEKLY reporter, Mr. Simon said that the man first came to his store last Thursday with an automobile clock which he desired to have repaired and that he returned on Saturday evening and paid for the work on the clock. He then looked at two diamond rings, and after trying them on, suddenly made a dash for the door. The jeweler followed him closely and chased him for several blocks, but when within 40 feet of the fugitive Simon fell and severely injured his ankle and the man escaped.

The thief is described as being about 23 years of age, with smooth face, rather light complexion, above the average height and of slight build. He was dressed in a dark suit and wore a long plaid coat. The rings taken were valued at \$300 and \$200, respectively. One of them was a single stone ring of one and three-quarter carats in weight on which was scratched the mark 20/5; the other was a three-stone ring and bore the number 2043.

Trans-Atlantic Voyagers.

FROM EUROPE.

B. Goldberg, Vincennes, Ind., returned recently on the *Mauritania*.

Emil Lewy, of Lewy & Cohn, New York, returned Thursday on the *Finland*.

Herman Abraham, of Cohn, Abraham & Co., New York, returned Jan. 30 on the *Kaiser Wilhelm II*.

TO EUROPE.

William Barthman will sail Saturday for a trip to the Mediterranean.

H. S. Morris, of the S. Cottle Co., New York, sailed Saturday on the *Lusitania*.

G. P. Umstead, of T. P. Umstead & Co., Newport, Ark., sailed last week on the *Adriatic*.

A. Schickerling, of the Elk Jewelry Mfg. Co., New York, sailed recently on the *Kaiser Wilhelm II*.

Alexander P. Maynard and John A. Potter, of Maynard & Potter, Boston, Mass., sailed Feb. 1 for the Mediterranean on the *Romanic*.

The "International Index for Watch and Clock Makers" for the year 1908 has just been issued. Its contents are such that its well-established character has been fully maintained. As a directory for the branch of business to which it is dedicated it serves its purpose thoroughly well. It is written in four different languages, and gives the names and addresses of important concerns in various parts of the world, including the principal cities in Europe, Asia, the United States, Africa, South America, etc. The book has a vocabulary of all the French, English, German and Italian expressions and terms used in horology and other interesting information. It is published under the direction of M. G. Tardy, and can be bought at 93 Boulevard de Port Royal, Paris. Its price is 12 francs 50 centimes or about \$2.50.

The ADVANTAGE of BUYING
UR RINGS

SPECIAL FACILITIES
in the manufacture of
UR RINGS enable you to
buy them through your
JOBBER as advantageously
as such goods can be obtained
direct from manufacturers



T. G. Cordi has commenced business in Roseville, Cal.

D. J. Phillips, Clinton, S. C., has added a line of jewelry.

C. Mitchler has begun business as a retail jeweler in Atlantic City, N. J.

Hedrick & Frisbie will soon open a new jewelry and optical store in Lancaster, Ky.

A. T. Taylor is about to open a new jewelry and repairing establishment in Atalla, Ala.

H. P. Proctor, Grinnell, Ia., recently purchased a jewelry stock in San Francisco, Cal.

A. Pollhammer, engraver, has opened a shop in the Kamm building, San Francisco, Cal.

B. Lieberman has opened a store on his own account at 709 Sansom St., Philadelphia, Pa.

John N. Taylor, Jr., will soon start in business for himself as a retail jeweler at 11 S. 9th St., Philadelphia, Pa.

L. C. Karo contemplates opening a general store in Portland, Wash., where he will carry, among other lines, a stock of jewelry.

I. A. Sisinger has started in the jewelry business at 1487 Russell St., Detroit, Mich., where he will carry a large line of jewelry and optical stock.

J. Starr, Walsenburg, Colo., has opened a watch repairing establishment at 1622 Arapahoe St., Denver, Colo., where he will do work for the trade only.

New Orleans, La.

M. Scooler has been conducting an auction sale.

James Conley was arrested last week on the charge of stealing a knife from a Canal St. jewelry store. When taken into custody a diamond ring was also found on him.

H. J. Keil, who has an antique furniture and jewelry store at 325 Royal St., caused the arrest last week of Martin E. Shoen, a former employe, whom he accused of stealing a ring worth \$60, a chain worth \$30, a necklace worth \$8, a diamond ring worth \$16.75 and a brooch worth \$16.

Edward S. Maunsil, formerly a director of the Louisiana and New Orleans exhibits at the Atlanta Exposition, is chairman of the Exhibition Committee of the Progressive Union for the Exhibit of Home Industries to be held this Spring. On this committee are several gentlemen connected with the jewelry trade, among the most prominent being Leonard Krower, the wholesale jeweler.

D. A. Pless, of the firm of D. A. Pless & Bro., Morristown, Tenn., is retiring, and T. A. Pless will continue the business alone. The retiring member will remain with the concern as an employe for the time being.

The Untermeyer=Robbins Co.

Seventy-One Nassau Street, New York



GOLD PLATED Art Jewelry of every description, and the Schickerling patented Elk and Eagle lines. Fine Diamond Mountings.

Q Makers of fashionable, popular price, ten and fourteen karat Solid Gold Jewelry. Card Holders for all Lodges, solid gold, sterling and plated. Artistic Novelties.

SCHICKERLING MFG. CO.

391-393 Mulberry Street, NEWARK, N. J.

CONRAD SCHICKERLING, Pres.

T. M. SCHROEDER, Treas.



TRADE  MARK

Bead Neck Chains

LINK BUTTONS, GOLD FOBS, RIBBON FOBS,
BRACELETS, GUARD CHAINS, NECK
CHAINS, VEST CHAINS

C. Sydney Smith & Co.

ESTABLISHED 1870

9-11-13 MAIDEN LANE

NEW YORK

FACTORY, PROVIDENCE, R. I.

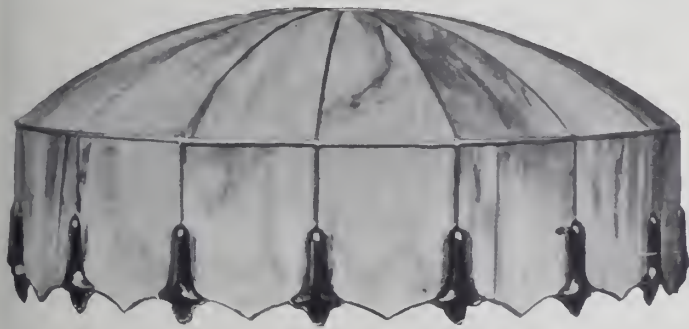

3030—16 in. Diameter

Unique Art Glass & Metal Co.

46 Park Place, NEW YORK

Makers of High Grade

ART GLASS DINING ROOM FIXTURES

Lamp Shades, Electric Shades
and Portables

CALL IN AND SEE OUR BEAUTIFUL LINE
OF PRODUCTS AT POPULAR PRICES ::

Also an elegant line of Rich Crystal Cut Glass
at Factory Prices

Rockford Watches Speak for Themselves.



Do not have New Cluster Heads made

We repoint Clusters, Marquise, Princess
and other fancy rings; we make them
like new at very reasonable prices.

One trial will convince you that we do
exactly what we claim. We make a
specialty of all kinds of repairing. Write
for price list—it will pay you.

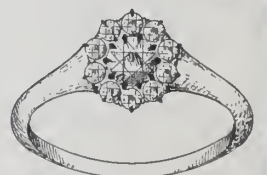

As received from Customer

ARONSON & SPIEGEL, 78 Nassau St., New York

As delivered to Customer

GORHAM SILVER

¶ The unexampled variety and diversity of Gorham silver designed to serve as Prizes and Trophies, are such as must appeal to the jeweler called upon to meet the oft-times fastidious demands of club committees and others charged with the task of selection.

¶ Vases, Loving Cups, Tankards and Special Pieces of every description, from the simplest to the most elaborate, in every style and at every price. Such, indeed, as cannot fail to appeal to the most exacting taste, are always in stock.

¶ Nor is the range of selection confined even to these wide limits. The Gorham Company is always ready to forward at short notice attractive sketches of artistic designs specially prepared to meet individual demands.

THE GORHAM COMPANY,



CHICAGO,
137 Wabash Ave.

Silversmiths and Goldsmiths

Fifth Avenue and 36th Street, New York.

BRANCHES:

NEW YORK,
23 Maiden Lane.

SAN FRANCISCO,
Temporary Office:
1103 Broadway, Oakland, Cal.



LONDON,
Ely Place.

WORKS: Providence and New York.

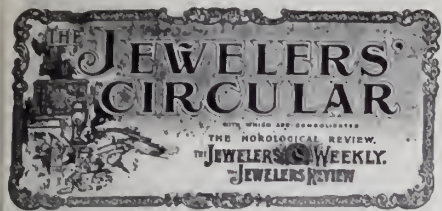

PUBLISHED EVERY WEDNESDAY BY
THE JEWELERS' CIRCULAR PUB'G CO.
 L. J. Mulford, Pres. & Treas. V. S. Mulford, V. P. & Sec.
 11 JOHN ST., COR BROADWAY, NEW YORK.
 TELEPHONE: 1148 CORTLANDT. CABLE ADDRESS: JEWELAR, NEW YORK.

VOL. LVI. FEBRUARY 12, 1908. No. 2.

Subscription in United States and Mexico, \$2.00
 Dominion of Canada, 3.00
 Other Countries in Postal Union, 6.00
 Single Copies, 10

Remit by check or money order. Remittances in money are at sender's risk.

Index to News and Special Articles.

	Page.
Handsome Trophy Presented by Mr. and Mrs. Andrew Carnegie to Princeton University Illustrated on front cover; text on	41
Interesting Collection of Pearls From Graves of Mound Builders	37
London Jewelry Fashions	39
Queen Victoria's Coronation Ring	39
The Effect of Radium on Corundum Gems	41
Bids Received and Contracts Awarded by Government to Supply Various Articles	43
Career of the Late Isaac Lloyd Blauvelt	43
Assets and Liabilities of Edwin W. Dayton, New York, as Shown by His Bankruptcy Schedules	43
Massachusetts Optometrists Take Steps to Oppose Bill Which Hits at Their Business. Post Office Inspectors Take Charge of Money Order Swindler and Check Forger Arrested at New Haven	45
Creditors File Bankruptcy Petition Against Chase Mfg. Co.	45
Jewelry, etc., Exported From New York	45
Robert M. Vail Acquitted of Charge of Complicity in Theft From Jeweler's Trunk	47
Assets and Liabilities of David Kessler as Shown by His Schedules	47
Thief Assaults Aged Albany, N. Y., Jeweler With Lead Pipe Bludgeon in Attempt to Rob Him	47
Death of Emanuel Hibarger	47
Involuntary Bankruptcy Petition Filed Against Jos. Brown & Co. by Creditors	47
Death of Henry Borsch	47
Imports at New York	55
Decision of Board of General Appraisers on Jewelry and Kindred Lines	57
Death of William Van Keuren	57
Check Swindler at Work in New York	57
Be Careful in Dealing With This Jewelry Case Repairer	57
Indictments Found Against Conrad Schickering On an Old Charge	59
Receiver Asked for in Suit Against Hahn-Butler Co.	59
Games Rolled by Jewelers' Bowling League	59
Attachment Filed Against J. H. Crandall, Los Angeles, Cal.	59
Gold Bars Withdrawn and Exchanged	59
Silver Market	59
Thief Steals Rings Valued at \$500 From Brooklyn Jeweler	59
Transatlantic Travelers	59
New Enterprises	60
Patent Department	81-83
Watch Repairing—(Continued)	85-87
Shakespeare and Clockmakers	87
Sun Dials and the Unification of Time	89
Stationery Selling by Retail Jewelers—(Concluded)	96
The Economy of the Trade Journal	97
A New System of Illumination	97
Keep Old Advertisements	97
Workshop Notes and Queries	99
Oxidizing Nickel Deposits	99
A Few Words on Nymphenburg Porcelain	101
Catala Invites Americans to Participate in a Great International Exposition	101
Peking Cloisonné Ware	101
An Original Design for a Silver Punch Bowl	101

FAILURES in jewelry and clock lines during the month of January, following the course of the failures in other lines of business, are larger, in number and amount of liabilities, than usual for the month. According to the table of failures by branches of business, compiled for *Dun's Review*, there were 63 insolvencies in the jewelry and clock trade with liabilities of \$1,105,161, or an average of \$17,542. According to the same table, there were 36 failures in January, 1907, with liabilities of \$377,060; 39 failures in January, 1906, with liabilities of \$336,022; 39 failures in January, 1905, with liabilities of \$271,495, and 52 failures in January, 1904, with liabilities of \$499,715.

Jewelers Swindled With Stolen Money Orders. **T**HE story in another column of the arrest and detention of a man who has been swindling many jewelers by means of false and forged post-office money orders, will no doubt be read with pleasure by some of his many victims in the trade. Even those who are not interested in the man should read the story and take warning therefrom that they may in future deal cautiously with those who present money orders in payment of articles of jewelry.

Many dealers seem to forget that though a money order may be on a genuine blank, the payee may be a swindler, and ordinary caution should suggest that the dealer have all orders verified at the post-office before accepting them in lieu of cash. This is no uncommon way of swindling the trade, as every robbery of a post-office has been followed by frauds upon retail jewelers who have accepted the stolen money orders from the thieves or their agents.

THE CIRCULAR-WEEKLY will endeavor in future to keep the trade posted as to the numbers of the post-office orders that are stolen from time to time, but the members of the trade should nevertheless insure themselves against fraud by accepting the post-office order but tentatively, refusing to deliver merchandise until the genuineness of the order and the identification of the payee has been established.

Should the Law Define "Solid Gold"? **A**S told in detail in THE CIRCULAR-WEEKLY last week, the executive committee of the American National Retail Jewelers Association, at a meeting held in Cincinnati recently, took steps favoring the amendment of the National Stamping Law, which will cover the term "solid gold," defining this as a quality mark and giving it the meaning of 10 karat or 10/24 pure gold. It was decided that an amendment of this character should be drawn and sent to Washington to be introduced with the backing of the association.

Though the committee acted with distinctly good intent in endeavoring to correct an evil which existed before the Stamping Law's enactment and may exist since its passage, we think it will an error to draw any amendment covering the marking of the words "solid gold" except after mature deliberation and an endeavor to obtain

Any business will grow under the combined influence of good management and good advertising

the consensus of the opinion of the trade, because a definition of the words "solid gold" as 10 karat will meet with almost as much opposition from manufacturers of high grade gold goods who never use the mark, as from those who make very low karat gold to be sold to the public under this deceptive title.

There is something worth considering in the contention that a legal definition of "solid gold" as 10 karat would result in a large amount of misunderstanding by and misrepresentation to the public. The term is a misnomer and one that has been used to cover a multitude of fraud, and to limit the term of 10 karat is bound to meet with opposition from those who think the term should be defined as meaning what the buyer and not the jeweler expects it to mean, or should be forbidden entirely. Every jeweler knows that a large proportion of his customers when asking if an article is "solid gold" and, assured that it is, feel that they have a substantially high karat object, and there are many people, if offered to choose between 14 karat, 18 karat and "solid gold," who would accept the last owing to the idea in their minds that "solid" is the equivalent to "entire" or "pure" gold.

In fact, it has been these "solid gold" lines which have been offered by department stores, catalogue houses and often by jewelers themselves at prices way below that which an article of a standard quality of gold can be made, that have been responsible for much of the trouble and unfair competition from which the retail jewelers suffer. To offer any real protection to the public, if the mark is to be defined as 10 karat, a campaign of education must be conducted before the public to explain its meaning. As far as silver is concerned the statute of most States provide indirectly, and several directly, that "solid silver" is synonymous with sterling silver, the highest grade of commercial silver recognized by name, and it is but natural on the part of the buying public to feel that "solid gold" then is an equally high proportion of gold and alloy.

Would it not be better, instead of defining "solid gold" as 10 karat gold in the statute, to define the word "gold" alone or in connection with other words, and not permit the name to be used on the cards or tags of any article containing a greater amount of alloy than the standard requires? This would cover the evils that the executive committee of the A. N. R. J. A. are trying to drive at, and not give a meaning to the words "solid gold" (as 10 karat) which many manufacturers and jewelers feel would help to confuse the public.

In any case, a hurried amendment to the

FIRST HANDS



CROSS & BEGUELIN

Importers and Cutters of Diamonds and Precious Stones

43 Rue de Meslay, PARIS

Telephone,
480 John

31 Maiden Lane, NEW YORK



The Silent Appeal

H. A. KIRBY

FINE
GOLD
JEWELRY

PROVIDENCE
NEW YORK

HAVE YOU EVER REFLECTED ON HOW A PRETTILY WROUGHT AND EFFECTIVELY DISPLAYED DESIGN WILL UNCONSCIOUSLY INFLUENCE A PURCHASE? HOW FIRST IT EXCITES ADMIRATION IN THE INDIFFERENT SPECTATOR, THEN IRRITATES THE DESIRE TO POSSESS, AND FINALLY BY ITS VERY IRRESISTIBILITY COMPELS HIM TO PURCHASE? IN EFFECTING SUCH A SALE, ONLY A FEW CONVENTIONAL REPRESENTATIONS ARE NECESSARY BY THE JEWELER, WHOSE PROFITS ARE A JUST REWARD FOR HIS SHREWDNESS IN EQUIPPING HIMSELF WITH SUCH JEWELRY. WE MAKE IT IN AN INEXHAUSTIBLE VARIETY—AT MODERATE COST.

National Stamping Law, drawn without first getting the opinion of the retail jewelers and manufacturers of the country, would be a mistake. It would be wiser to do as the Missouri jewelers have done and start a campaign of education to show that the term "solid gold" is a misnomer and in every way possible try and stop the use of it on jewelry products, both by legislation and by refusing to handle any articles which bear the mark without a distinct quality stamp in addition.

LETTERS TO THE EDITOR.

An Appreciation of the Anniversary Number.

NEW YORK, Feb. 8, 1908.

Editor THE JEWELERS' CIRCULAR-WEEKLY:

We desire to compliment you on the very interesting anniversary number just received. You are quite right in celebrating your birthdays, and we congratulate you very heartily on this occasion. We find your publication improving with age. The contents are increasing in interest and educational value, and you are bringing to the foreground an element which we jewelers have too often neglected, one which is most essential, namely, beauty.

This consideration on your part is well exemplified in the cover design of your anniversary number, which in its composition and coloring is most beautiful and delightful to the eye. We notice with pleasure that the design is the work of that talented artist, who ranks among the best jewelry designers of America.

With renewed best wishes for your continued success. Yours very truly,

THEODORE A. KOHN & SON.

Kind Words from a British Contemporary.

ENGLAND'S leading jewelry journal, *The Watchmaker, Jeweler, Silversmith and Optician*, of London, has this to say in its last issue as to THE CIRCULAR-WEEKLY'S fight against misrepresentation by daily newspapers of the conditions in the jewelry trade:

"Our forceful American contemporary, THE JEWELERS' CIRCULAR-WEEKLY, always to the front with special news relating to the gem markets, and smart to deal with the cheap-jack editors and sensation mongers who make capital out of the jewelry trade, has publicly challenged those who, through the medium of the ordinary press, have spread misleading information abroad concerning the diamond market. It is well known, our spirited contemporary remarks, that while bargains may be had at this time of year in the jewelers' shops, diamonds still stand firm so far as prices are concerned and are 'the only commodity sold at market price.' In a trenchant article THE JEWELERS' CIRCULAR-WEEKLY urges upon its readers the importance of dealing with the papers which publish untruthful and misleading statements concerning the present position of the diamond market. The view of our contemporary are well grounded, and we can state, with knowledge gained upon the spot, that for some time prices will remain steady and firm."

New York Notes.

I. E. Anthony, Comanche, Ia., was a visitor in this city during the past week.

Benjamin Arnstine, of the Arnstine Bros. Co., Cleveland, O., was a visitor in this city recently.

J. F. Ruggles, with W. H. Bell & Co., Attleboro Falls, Mass., visited friends in town recently.

B. Goldberg, a pearl dealer of Vincennes, Ind., has returned on the *Mauritania* from Europe to this city.

Goldmuntz Bros., importers of diamonds, have moved from 71 Nassau St. to the Fulton building, 87 Nassau St.

Otto A. Schultz, of Schultz-Jerseman Mfg. Co., 105 Maiden Lane, is at present making a trip through the west.

The Follett Time Recording Co. has leased the first loft of the Herring building at 18th St. and Ninth Ave.

H. B. Rogers, of Rogers & Co., 53 Ann St., left for his western trip through Pennsylvania, Ohio, Michigan and Wisconsin and the west last week.

E. H. Dean and H. E. Reich have severed their connection with the Cooper Diamond Co., preparatory to beginning a general jobbing business under the style of E. H. Dean & Co.

Herman Abraham, of Cohn, Abraham & Co., 9 Maiden Lane, returned from a visit to the European diamond centers Jan. 30 on the *Kaiser Wilhelm II.* He has been broad some time.

G. P. Umstead, of T. P. Umstead & Co., pearl dealers of Newport, Ark., and Vincennes, Ind., sailed on the steamer *Adriatic* from this city recently for Europe. He will be absent about a month.

Kent & Woodland, 14 John St., in addition to their own line of bracelets, etc., are now selling agents for Theberath & Co., Inc., of Newark, in which concern they recently acquired a controlling interest.

A meeting of the creditors of S. Hart, Waterbury, Conn., was held yesterday at the Everett House, Union Sq. Mr. Hart was burned out on Dec. 30, the fire destroying a large part of his goods, those which remained being of little value.

The Metcalf Co., 2 W. 39th St., has now on exhibition at its salesrooms an antique English urn, which once belonged to the Count of Flanders, brother of the King of Belgium. The urn has the Belgium coat-of-arms engraved on the front.

Wm. L. Stone, who was formerly in the downtown store as city representative of the Gorham Co., but more recently with the Baldwin Steel Co., has just been made the manager of the factory and umbrella department of the Gorham uptown store.

Thomas James, who has been a familiar character at the corner of Canal St. and the Bowery for a number of years past, where he sold jewelry from a tray, died in the Kenmore Lodging House, 160 Park Row, last week. James had lived in the Kenmore Lodging House for 17 years.

Mrs. Hager Cohn, mother of Louis Cohn, of Henry Freund & Bro., 71 Nassau St., died at her late home, 461 E. 140th St., Jan. 29. The funeral services were held at the residence the following Friday morning. Friends in the trade extend sympathy to Mr. Cohn in his bereavement.

For Rosenzweig Bros., 51 Maiden Lane, Henry Harris, covering New York State and New England; W. R. Pratt, traveling in the middle west; and P. H. Marks, in the south and northwest, have all started out on their trips. Max Rosenzweig and Albert Rosenzweig are also covering their usual territory.

Reed & Barton have on exhibition at their Fifth Ave. salesrooms the prizes to be awarded at the National Indoor Championship Lawn Tennis Meet, to be held in the Seventh Regiment Armory, 66th St. and Park Ave., beginning Feb. 8. The trophies include a variety of useful and artistic products of the silversmith's art.

A. Schickerling, of the Elk Jewelry Mfg. Co., 51 Maiden Lane, sailed recently for Europe on the *Kaiser Wilhelm II.*, bound for Halberstadt, Germany, whither he has been called by the death of his father. He will be away about a month, and during his absence the business will be under the direction of Henry Armsheimer.

Wm. H. Stewart, 234 E. 19th St., Brooklyn, died from apoplexy, while attending the services in St. Paul's Episcopal Church, recently, in the vestry. He was born in Waterbury, Conn., 71 years ago, and has been connected with the jewelry business in this city for a number of years. The deceased is survived by a widow.

Wm. C. Gleason, who died recently at his home, 80 Hanson Pl., Brooklyn, had been for a number of years connected with the jewelry manufacturing trade. He was born in Arlington, Mass., in 1862 and was known in the trade in this city and Boston for the past 18 years. A widow and his father and mother survive him.

Geoffroy & Co. is the name of the company which has been incorporated under the laws of the State of New York, to deal in jewelry, with a capital stock of \$50,000. The directors are: Nicholas Geoffroy, Henry H. Kaufman and Martin C. Anson, all of New York. Mr. Geoffroy has been in the manufacturing jewelry business for many years.

Abe Kassel, manufacturer of jewelry boxes, etc., 675 Hudson St., recently sold out his stock at auction. His business was established in 1900 at 53 W. 13th St. by F. Nadelman, who admitted Mr. Kassel on Feb. 1, 1901, under the style of F. Nadelman & Co. In 1903 the partnership was dissolved and Mr. Kassel continued the business alone, subsequently removing to the above address.

The special committee on the exhibits to be shown by the Metropolitan Museum of Arts, as was announced in the November Bulletin of the Museum, have named Tuesday, March 3, for the public opening of the St. Gaudens Memorial exhibit, which will be arranged in the Fifth Ave. entrance hall; the catalogue in the course of preparation will contain a list of the exhibits with historical information regarding the works exhibited. The reception to the friends of the Museum will be held on Monday, March 2.

There has been on exhibition during the past week at the Fifth Ave. salesrooms of Black, Starr & Frost, the prizes which will be awarded at the Westminster Kennel Club Dog Show for 1908, which is to be held at

Madison Square Garden, Feb. 11, 12, 13 and 14. The trophies, which were made by the concern exhibiting them, include cups for the different classes of dogs exhibited. Among those offering prizes are: L. Eldridge, Roswell E. Eldridge, Oscar Donner, Chas. H. Mackey, George B. Hopkins and H. K. Knapp.

The Diamond Point Pen Co., 100 Beekman St., has recovered from the effects of the fire which occurred there recently. The two upper factory floors have been working for the last 10 days. The shipping floor and office, however, is in such condition that it may take four to six weeks to renovate and put in tenable condition. The office and shipping rooms have been moved to 86 Fulton St., where all correspondence should be addressed. The three floors which the concern occupied in Beekman St. will be used for manufacturing purposes only.

H. A. Groen, president of the United Diamond Mining Co., British Guiana, and also a member of the firm of H. A. Groen & Bro., 51 Maiden Lane, has just returned from a prospecting trip in British Guiana after an absence of six months, three of which he spent in the interior where the properties of the United Diamond Mining Co. are located. Mr. Groen brought back with him interesting specimens of diamonds and gold taken from the properties belonging to the company, and also has a most interesting collection of photographs depicting the manner of living and customs of the people of that country and the work being carried on there by the firm. The properties of the company are about 200 miles inland.

Wm. F. Mannix, who says he comes from Carthage, N. Y., was arrested in Montreal recently, and news received at police headquarters in this city discloses the method by which Tiffany & Co. were robbed of jewelry worth more than \$500. R. M. Hyde, superintendent of Tiffany & Co., is the plaintiff against Mannix. A warrant was obtained on which Mannix was arraigned in the Jefferson Market Court in December. The theft of the jewelry occurred on Nov. 27 and 30. According to the report Mannix presented a reference to the jewelers purporting to be from an official of the High Falls Paper Co., of Chautauqua, N. Y., and another from the proprietor of the Lewis House at Carthage, and on the strength of these the jewelers let Mannix have two gold watches and chains, two silver watches, two diamond rings and three gold and silk fobs on Nov. 27, and on Nov. 30 three more gold watches. He took these goods on approval, and when he failed to pay for them within a reasonable time his references were investigated, and it was learned that they had been forged.

A meeting of the creditors of Louis Cohn, 357 Grand St., was held at the Astor House last Wednesday, at which time a statement was made showing his liabilities to be about \$30,000, with assets of about \$25,000, of which one-half is stock and the rest in peddler's accounts. Mr. Cohn wished to pay his creditors 100 per cent. on the dollar in notes of one, two and three years, but it was the opinion of the creditors that it would be better, in view of the debtor's long and honorable career, to give

(New York Notes continued on page 69.)

ESTABLISHED 1852

THE NASSAU BANK

Original Clearing House Member

Corner Nassau and Beekman Streets

NEW YORK

Title Guarantee and Trust Co.

176 Broadway (between John St. and Maiden Lane), New York

Capital and Surplus - - - - \$12,000,000

Deposits received subject to Check. Interest allowed. Letters of Credit issued. Drafts drawn on Great Britain and the Continent. All Banking Facilities afforded to Customers. Accounts of Jewelers are especially solicited.

Finance Committee in Charge of Banking Interests

E. T. BEDFORD, 26 Broadway
 C. H. KELSEY, President
 E. L. MARSTON, of Blair & Co., Bankers
 W. H. NICHOLS, General Chemical Co.

CHARLES A. PEABODY, President Mutual Life Ins. Co.
 JACOB H. SCHIFF, of Kuhn, Loeb & Co.
 JAMES SPEYER, of Speyer & Co.
 E. O. STANLEY, 2d Vice-President

BRANCH BANKING OFFICES: 196 Montague St. and 175 Remsen St., Brooklyn; 350 Fulton St., Jamaica; 67 Jackson Ave., Long Island City

The Market and Fulton National Bank of New York.

ORGANIZED 1852

81-83 FULTON STREET.

Capital, \$1,000,000. Surplus, \$1,500,000.

PROGRESSIVE — CONSERVATIVE — SUCCESSFUL.

ALEXANDER GILBERT, President.
 R. A. PARKER, Vice-President.
 T. J. STEVENS, Cashier.
 JOHN H. CARR, Asst. Cashier.

Invites the Accounts of Jewelers.
 Will extend every facility that good banking will justify

SAFE DEPOSIT VAULTS.

THE STATE BANK

376-378 GRAND STREET, NEW YORK

Capital and Earned Surplus, over \$1,500,000. Deposits over Fifteen Millions.
 Offers a favorable market for short and long time jewelry and diamond paper.

The Mercantile National Bank

OF NEW YORK

February 4, 1908

ASSETS

Loans and Discounts	\$6,992,758.84
U. S. Bonds.....	1,009,125.00
Bonds to Secure U. S. Deposits	959,357.50
Real Estate and Securities	1,018,800.00
Due from Banks and Bankers	341,581.72
Exchanges for Clearing House	286,689.24
Cash	1,395,968.50

\$12,004,280.80

LIABILITIES

Capital	\$3,000,000.00
Surplus and Undivided Profits	2,407,236.31
Bank Notes Outstanding	975,000.00
Deposits	5,285,044.49
Bond Account	337,000.00

\$12,004,280.80

SETH M. MILLIKEN, President

MILES M. O'BRIEN, Vice-President

EMIL KLEIN, Cashier

WM. SKINNER, Vice-President

ALFRED W. DAY, Assistant Cashier

GERRISH H. MILLIKEN, Vice-President

DIRECTORS

WILLIAM F. CARLTON,
WILLIAM NELSON CROMWELL,
EDWIN GOULD,
HAROLD A. HATCH,
EDWARD T. JEFFERY,

GERRISH H. MILLIKEN,
BENJAMIN NICOLL,
MILES M. O'BRIEN,
CHARLES E. PERKINS,
DICK S. RAMSAY,
JOHN F. KEHOE,

GEORGE H. SARGENT,
WILLIAM SKINNER,
WILLIAM H. TAYLOR,
WARNER VAN NORDEN,
S. M. MILLIKEN.

Strictly a Commercial Bank
Accounts Solicited

1851

THE JEWELERS' BANK FOR HALF A CENTURY
IN THE SAME LOCATION

1908

The Chatham National Bank

Broadway and John Street
New York

CAPITAL - - - - -	\$450,000
EARNED SURPLUS - - - - -	\$1,000,000

NOT CONNECTED WITH ANY OTHER INSTITUTION, OR CONTROLLED BY ANY SINGLE INTEREST,
INVITES THE ACCOUNTS OF MERCHANTS, FIRMS AND BUSINESS CORPORATIONS, AND IS
PREPARED TO EXTEND EVERY FACILITY CONSISTENT WITH CONSERVATIVE BANKING

Directors

GEORGE M. HARD, President
JOHN H. WASHBURN, Retired
SANFORD H. STEELE, Vice-President
General Chemical Co.
FRANK R. LAWRENCE, Attorney
DANIEL J. CARROLL, Lumber
JOHN D. VERMEULE, President
Goodyear India Rubber Glove Co.
G. P. MOROSINI, Banker

HENRY F. SHOEMAKER, Banker
WILLIAM B. CONRAD, White Goods
FRANKLIN S. JEROME,
Treasurer U. S. Finishing Co.
FRANK J. HEANEY, Exporter
SAMUEL WEIL, Capitalist
LEWIS COON, Real Estate
O. G. FESSENDEN,
of Hayden W. Wheeler & Co.,
Jewelers.

GEORGE M. HARD, President

WILLIAM H. STRAWN, Cashier

HENRY L. CADMUS, Assistant Cashier

New York Notes.

(Continued from page 65.)

him a chance to get on his feet again, so they submitted a proposition that he pay 50 cents on the dollar in six, 12 and 18 months. The creditors appointed Mr. Levy, of Freudenheim Bros. & Levy; Mr. Kohn, of Alois Kohn & Co., and Richard Friedlander, of R. L. & M. Friedlander, to investigate the matter and report as to the most advisable action to take. The creditors speak very highly of Mr. Cohn, and it is evident that he is held in high respect by them. He will start in business shortly with his son, under the style of Louis Cohn & Son. The 50 per cent. settlement as proposed admitted the acceptance of the debtor's own unendorsed notes.

H. S. Morris, of the S. Cottle Co., 31 E. 17th St., sailed Saturday for Europe on the *Lusitania*.

William Barthman, 1 Maiden Lane, sails Saturday for Naples. He will be absent about two months.

A judgment has been recorded in the county clerk's office against Louis Goldman in favor of A. Anzlewitz & Co., for \$335.41 for goods sold and delivered.

Prentice Luckey, manager of the diamond department of Geo. T. Brodnax, Inc., Memphis, Tenn., was a visitor in this city, last week. He stopped at the Hotel Imperial.

Rudolph C. Schwarzkopf is now representing the Woodside Sterling Co. on the Pacific coast, while James F. Gorman is representing the same firm in the middle west.

Mortimer Bernheim, after being away for four weeks because of illness, has entirely recovered and is now back at his desk in the office of the Woodside Sterling Co., 192 Broadway.

The firm of N. Moskowitz & Bro., 71 Nassau St., has been dissolved. N. Moskowitz will continue in business at 71 Nassau St., and Julius H. Moss, the other partner, will continue in business at 14 Maiden Lane.

H. F. Stapleford, with Dan I. Murray, jewelry auctioneer, 3 Maiden Lane, is conducting a sale of diamonds, jewelry, watches and other goods for the H. Howard Co., 479 Fulton St., Brooklyn, which must vacate its store by March 1.

The firm of Black, Starr & Frost has been incorporated under the laws of the State of New York, to deal in jewelry, with a capital of \$1,000,000. The directors are: Mary G. W. Black, Robert C. Black and Witherbee Black, Pelham Manor, Westchester County.

The contract for the furnishing of the silver service for the cruiser *Chester* has been awarded to Tiffany & Co. The service will be presented to the warship in Philadelphia, on June 15. It will include a punch bowl, tray and ladle, which will cost \$2,000.

The partnership existing between Isidor Scharaga and Isaac Golden, 238 Bleecker St., was recently dissolved, and Mr. Golden, who retired, has bought out the jewelry store of Charles Kahan, 328 E. 125th St. Mr. Scharaga continues the old business and liquidates for the old firm.

Emil Lewy, of Lewy & Cohn, 530 Broad-

way, returned Thursday on the *Finland*. Mr. Lewy has spent some time in the European markets and has returned with the latest and richest selection of high grade cameos, corals, etc., that he has ever before been able to obtain.

David S. Michel has withdrawn from the firm of M., J. & D. Michel, 18 E. 14th St., to become buyer of jewelry, silverware, clocks and leather goods for the "14th St. Store." The remaining partners of Mr. Michel's old firm will hereafter continue business under the style of M. & J. Michel.

Earle R. Sheppard, 53 Maiden Lane, manufacturer's agent, has made arrangements to handle a line of the Baltimore Sterling Silversmiths Mfg. Co., who make flatware and fancy pieces. He is at present in Baltimore visiting the trade for the Elk Jewelry Mfg Co. and the Littlefield Silver Co.

Higgins & Seiter, china and cut glass dealers, moved, Monday, from 52 W. 22d St. to a new 12-story building, which has just been completed at 56 W. 22d St. They have opened one of the largest exclusive glassware stores in the country. The store occupies the entire ground floor of the new building.

Creditors of A. L. Hodes are notified that the first meeting of creditors will be held at the offices of William Allen, referee in bankruptcy, 67 Wall St., on Feb. 20, at 10.30 o'clock in the morning, at which time the creditors may prove their claims and appoint a trustee and transact such other business as may properly come before the meeting.

At a meeting of the stockholders and directors of the Solidarity Watch Case Co., the following officers and directors were elected for the year 1908: President, D. E. D. McMurray; vice-president, Harry C. Ballay; secretary and treasurer, Louis J. Montagnon; directors, D. E. D. McMurray, George Salzgeber, Louis J. Montagnon, Clarence B. Ensley, Harry C. Ballay, Frederick R. Sprake and Oscar M. Gammon.

Ida Rowland, 81 Puntine St., Jamaica, who is employed in a diamond polishing establishment in this city, made the discovery last Saturday that she was carrying around in her hair a diamond valued at \$1,000 without knowing it. The stone flew from beneath the workman's hammer while he was setting it and lodged in Miss Rowland's hair as she was passing. A search was made for the lost diamond, but it was not located until Miss Rowland appeared with the stone.

Benjamin Westervelt, who has been looking after the New England Watch Co.'s interests in greater New York, was recently taken ill with appendicitis at his home in Mt. Vernon and underwent an operation Jan. 30 at the Mt. Vernon Hospital. The operation was performed by Dr. Thomas F. Goodman, of that city, since which time Mr. Westervelt has steadily improved, and prospects are bright for a quick and permanent recovery. Mr. Westervelt's many friends in the trade will be glad to hear of his convalescence.

Daily papers during the past week have contained a report of the elopement of Catherine Geggenbach, the daughter of Charles W. Geggenbach, 66 Greenwich

Ave., and Richard Bell. It was also stated that the young lady took about \$1,000 worth of jewelry from her father and that the couple were located in Chicago and arrested last Tuesday. They had visited several cities and had pawned much of the jewelry. They were arrested and brought back to this city, where they were both held in \$1,000 bail to await trial on the charge of stealing the jewelry.

A meeting of the creditors of L. Witschhausen, against whom a petition in bankruptcy was recently filed, was held at the offices of Referee Willis, 80 Wall St., Tuesday afternoon of last week, at which time John Drake, with the R. F. Simmons Co., was appointed trustee. The bankrupt's attorney proposed a settlement of 50 per cent., 25 of the 50 per cent. in cash and the rest in four notes of equal payments at four, eight, 12 and 16 months. A meeting was held Thursday of the previous week, but was adjourned after a short session. The next meeting will be held Thursday, Feb. 13, at two p. m., at the same place.

Louis Block, who was for many years well known in the Maiden Lane district, committed suicide at his home, 3 W. 117th St., early last week, and the funeral services were held Feb. 4, the interment being in Washington Cemetery. Mr. Block, who was about 34 years old, was born in Elmira, and when a young man was employed by Roseman & Levy, remaining with the concern and its successor, A. Roseman, from 1886 to 1902. During this time he became well known in the jewelry district and made many friends. After quitting Mr. Roseman he went into the real estate business, but was not successful, and it is believed that financial troubles preyed upon his mind. The deceased was married about five years ago, and is survived by a widow and a young son.

Burglars gained entrance to the fountain pen factory of Nathaniel Field, 79 Centre St., Sunday morning, Feb. 2, and succeeded in getting away with about \$1,200 worth of jewelry, fountain pens, watches and ornamental hat pins. They entered through a hallway by means of a pass key, and then, with an auger, bored holes in the partition and cut an opening large enough to admit them. A wooden trunk, in which was jewelry, watches and fountain pens in an unfinished condition, was broken open and the contents packed in sacks, one of which was found on the floor of the office. It is the opinion of the police that there were three or four men connected with the job. The till was relieved of stamps to the value of \$12, but the safe was not touched. The goods stolen consisted of New Haven watches in gun metal, gilt and nickel cases. There were also some pedometers, and a few pocket roulettes; also some Swiss watches, among which was an eight-day watch in a filled case. The jewelry consisted of gun metal, hat pins set with translucent enamels, cigarette cases, match safes and miscellaneous novelties. The fountain pens were in various stages of manufacture, all stamped with the name of Mr. Field. There was also a lot of self-filling pens, stamped "Sackless-Sukshun." A number of gold-filled bands for ornamenting fountain pen holders also disappeared.



GNTERPRISING and successful jewelers everywhere are pushing the sale of some individual line of watches which they believe to be superior to all others, and upon which they can also make a satisfactory and justifiable profit.

This explains the growing demand for **ILLINOIS WATCHES**, in 0, 12, 16 and 18 sizes, by increasing numbers of leading jewelers throughout the United States.

If you are not familiar with the superior quality of—and advantages gained by handling—Illinois Watches, it will mean reputation and dollars for you to investigate.

Every one fully guaranteed.

Price List sent on application.

ILLINOIS WATCH COMPANY
SPRINGFIELD

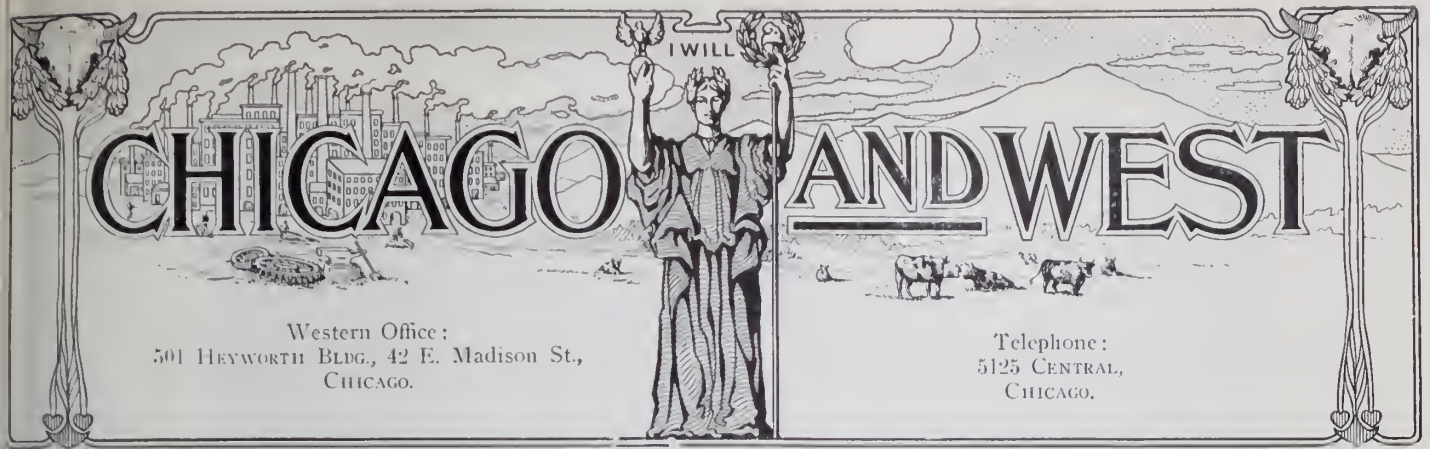

Western Office:
501 HEYWORTH BLDG., 42 E. Madison St.,
CHICAGO.

Telephone:
5125 CENTRAL,
CHICAGO.

Chicago Notes.

"Steve" Bridges is back from the coast. Al. Kolker is on a trip to the northwest. W. S. Sparrow has returned from the Pacific coast.

S. E. Eppenstein and wife are at Hot Springs, Ark.

Clarence Roehr is on a trip to St. Louis and Kansas City.

Wm. H. Carew, Streator, Ill., was a visitor here last week.

Harry E. Jones is back from a trip to St. Louis and the northwest.

John Pyl, of Pyl & Wykkel, Kalamazoo, Mich., was here last week.

Frank T. Barton and H. E. Farquharson have returned from the Pacific coast.

Charles C. Thoma, Battle Creek, Mich., will shortly hold an auction sale in that town.

Mr. Blatt, formerly with Lyon Bros., is now buying for the jewelry department of that house.

A. W. Adcock, vice-president of the Shourds, Adcock, Teufel Co., is seriously ill at his home.

Elliott C. Shourds, cousin of Clayton B. Shourds, died last week in St. Louis, of which city he was a resident.

Burt J. Miller, with the R. Wallace & Sons Mfg. Co., was married last Saturday to Miss Mamie Agatha Barendt.

Aphonse Judis, San Francisco, accompanied by his wife and son, stopped over here a day last week on his way east.

Ike Weiler, jewelry buyer for Lyon Bros., has severed his connection with that firm to become jewelry buyer for N. Shure & Co.

Max F. Noack, retail jeweler of Santa Rosa, Cal., left for that place last week after a visit to his mother at Watertown, Wis.

Miss Mulcahy, formerly buyer of the jewelry department of the Boston Store, is now buyer for the jewelry department of "Hillman's."

A majority of the creditors of Sigmund Ascher, 444 Milwaukee Ave., have signified their intention of accepting 50 cents on the dollar for their claims.

S. W. Crofts, formerly in the retail jewelry business at Greenland, Mich., was here last week and announced his intention of opening a store in Marshall, Ill.

Julius Wise, of J. S. Lehrberger & Co., San Francisco, Cal., stopped over here one day last week on his way to Memphis, Tenn. Mrs. Wise accompanied him.

The premises of the Calumet Watch Co. (Bath & Co.), 91 Dearborn St., were injured by fire last week. Nearly all the stock was in the fireproof vault and escaped injury. About \$3,000 damage was done, but this is fully covered by insurance. The temporary office of the company is at 59 Dearborn St., room 208.

Harriett B. Emerson, mother of Fred Emerson, with Rettig, Hess & Madsen, died last week and was buried on Thursday from her late residence, 339 N. Central Ave., Austin. The interment was at Forest Home Cemetery. Mr. Emerson was on the road at the time of his mother's death, but was fortunately reached by telephone. Mr. Emerson has the sympathy of the trade in his bereavement.

An involuntary petition in bankruptcy has been filed against Giovanni Faraco, retail jeweler at 241 Milwaukee Ave., and Wm. F. Zibell has been appointed receiver under a bond of \$2,000. The petitioning creditors were countrymen of Faraco's, and their claims aggregated \$800 for money loaned. The receiver's inventory estimates the assets as stock, \$1,642; fixtures, \$450, and book accounts, \$1,053. The liabilities are estimated at about \$3,000.

The Madsen-Steele Co., a mail-order jewelry concern in the Masonic Temple, has sent a circular letter to its creditors, asking for an extension of credit. The concern purposes to pay 20 per cent. cash, 20 per cent. July 15, 20 per cent. Dec. 15, 1908, and 40 per cent. Jan. 15, 1909, secured by firm notes without interest. The managers declare they have assets of \$43,595 divided as follows: Merchandise, \$31,613; book accounts, \$10,261; fixtures, \$1,422; stationery, \$174, and cash, \$118. They declare their liabilities to be \$29,364, leaving a surplus of \$14,231.

Keil & Hettich, an old established retail jewelry concern, now at 94 State St., has announced its intention to retire from the jewelry trade, May 1, and will sell the stock at auction through Briggs & Dodd. The concern is a corporation, with Leo Hettich and his son, H. L. Hettich, in active charge of the business. Mr. Hettich, Sr., is 70 years old, and intends to take things easy for the balance of his life. The stock has an invoice value of \$60,000. The business was established by M. Keil in 1871 on W. Madison St., and 25 years ago Mr. Hettich, who was manager for A. H. Miller, then one of the leading jewelers of Chicago, became a partner of Keil. They occupied

stores on Randolph and Washington Sts., and have been in their present location 11 years.

Jacob Lazarus, 18 years old, a clerk in the employ of Emil Braude & Bro., wholesale jewelers in the Heyworth building, was arrested last week, charged with the theft of a large quantity of jewelry. Lazarus had been in the employ of the firm for three years, and was implicitly trusted. Of late many articles of gold jewelry had been missed, and after a watch was set on Lazarus the firm suspected that he was the thief. After his arrest Lazarus confessed that he had been stealing for eight months, and named Nathan Vogel, a retail jeweler, 316 W. 12th St., as the man who received the stolen property. Vogel was arrested and acknowledged he had bought jewelry from Lazarus, but denied any criminal knowledge. Both men are out on \$500 bonds. Vogel kept a regular set of books with Lazarus. These show he had paid Lazarus \$1,500 for jewelry bought and owed him \$200 on account. Braude & Bro. think the thefts will amount to between \$5,000 and \$6,000.

St. Louis.

Alton's city officials have completed arrangements to have the town clock repaired, which has been causing citizens no little annoyance.

Mrs. A. C. Filson, Flora, Ill., while partaking of raw oysters at a club dinner last week found a perfectly formed pearl which a local jeweler estimated to be worth \$15.

Negotiations are reported for the sale to Simon Van Raalte, of S. Van Raalte & Co., of the seven-story building at the northwest corner of 16th and Locust Sts., for \$400,000. The property has a frontage of 50 feet on Locust St., and extends back to St. Charles St. on 16th St.

Hugh Murphy, a veteran jeweler, died here of gastritis last Wednesday, at the age of 71 years. He was retired at the time of his death, but had been in business for many years on S. Jefferson Ave. The funeral was held Saturday morning at 8:30 o'clock from the family residence, 2009 California Ave. Requiem mass was said in St. Kevin's Church. Interment was in Calvary Cemetery. Mr. Murphy formerly lived in Huntsville, Mo., where he was a member of Huntsville Lodge No. 30, A. F. & A. M. The deceased is survived by his widow and seven children.

Interior View of } **LEFFERT'S JEWELRY STORE-COUNCIL BLUFFS, IOWA** { Branch at PORTLAND, ORE.

Below is one of the many letters we get from our customers

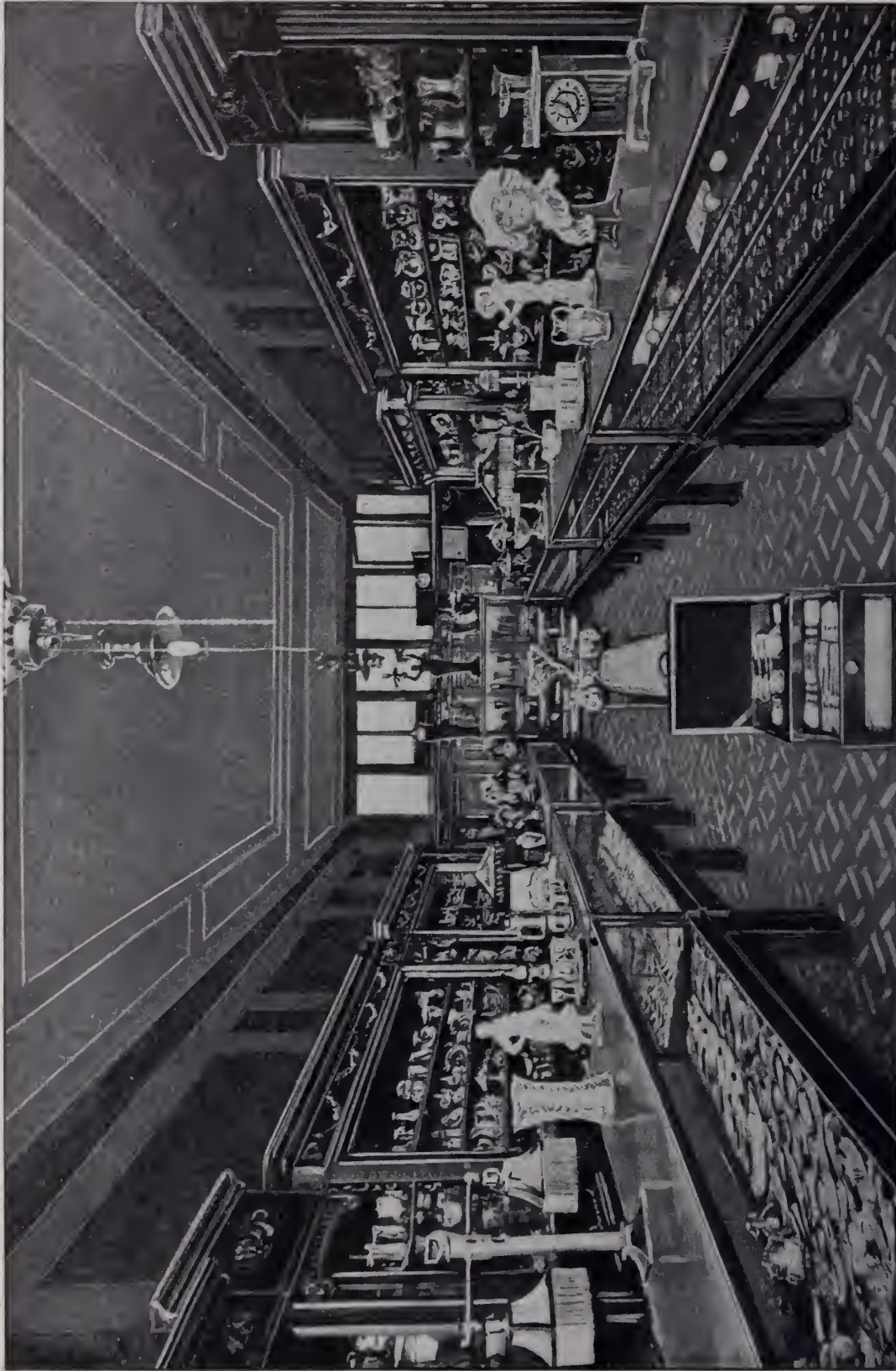

THE ARNSTINE BROS. COMPANY, Cleveland, O.:

Gentlemen—We wish to testify to the efficacy of our catalog, as furnished by your house, as a "Puller." It was given the supreme test during the recent holidays, and proved its worth. The financial slump made things look a bit dubious for a time, coming as it did right at the beginning of the holiday buying season. We went ahead, however, and covered our territory thoroughly with the catalog, and awaited results.

The catalog did the business. It represented our goods in such tempting shape that people seemed to forget the panic. Of course, we did other advertising, but we know from remarks made by customers that the catalog was at work all the time, everywhere.

As a result, we brought up at the end of the holidays with a better showing than last year, which we consider going some in the face of the financial breakdown. All honor to our catalog. Very truly yours,

EMIL H. LEFFERT.

**HOW TO INCREASE YOUR BUSINESS TOLD IN 6 WORDS—
Use The Arnstine Brothers Company's Catalog**

Cincinnati.

E. F. Douglass, Dysart, Ia., was here last week as a delegate to the canners' convention.

A. J. Augustin, of the Dennison Mfg. Co., was in Chicago, Ill., on business last week.

Edgar Fox, of Lindenberg & Fox, is visiting the trade in Ohio and Indiana this week.

C. W. Lucius, of the Frank Herschede Co., is again at business after an attack of grippe.

A. M. Plaut, of the National Jewelry Co., has left on a trip in Kentucky and Tennessee.

John A. Herschede, of the Herschede Fall Clock Co., has left on his regular western trip.

Hedrick & Frisbie, Lancaster, Ky., spent a few days here last week, buying their opening stock.

Elias Weinman, a wholesale jeweler of Philadelphia, Pa., was here a few days last week on business.

Gustave Fox, of the Gustave Fox Co., and party have returned from their pleasure tour in the south.

J. C. Conn, of the Conn Jewelry Co., Bowling Green, Ky., was the guest of Lindner & Co. a few days last week.

A. T. Taylor, Atalla, Ala., purchased his opening outfit here for the new jewelry and repairing store which he is opening.

Albert M. Dueber, president of the Dueber-Hampden companies, spent a few days here among the trade last week.

William Pflueger, of Joseph Noterman & Co., has been made a Royal Arch Mason of the Covington, Ky., Chapter No. 35.

Dan I. Murray, a well-known auctioneer, is recovering from an attack of illness with which he was stricken while in this city.

C. H. Creighton, Morrow, O., is arranging for a settlement at 40 cents on the dollar with creditors and will continue his business.

T. Zurbrugg, president of the Philadelphia, Crescent and Keystone Watch Case companies, with C. M. Fogg, of the Keystone Watch Case Co., was a recent caller here.

The store of A. & J. Plaut was closed Tuesday and Wednesday of last week, owing to the death of Mrs. Plaut's mother, Mrs. Sigmund Levi, who died in her 86th year.

Harry Ellwert, foreman of the factory of the Gustave Fox Co., celebrated his 16th year with the company last week by a banquet which he tendered the factory employees.

Chase Hoffman, of the Arcade Jewelry Store, Springfield, O., stopped over here on his way home from Texas, Mexico and Oklahoma, where he has real estate interests.

S. C. Petit, watchmaker for John F. Krohme, Jr., Clarksburg, W. Va., came to Cincinnati, Feb. 2, to meet his bride, who came here from Indiana. The marriage took place Feb. 3, after which the couple left on a bridal tour.

The many friends in the trade of Fred. Schwertfeger regret very much to hear of his sudden death, Feb. 3, of heart failure. Deceased for some years was associated

with Michie Bros. as foreman of their factory. A widow and one son survive him.

Ira B. Wylie, of Springfield, who was adjudicated a bankrupt, May last, has recently applied to the United States District Court for a discharge of all his debts in bankruptcy. A hearing will be held before the United States District Court in this city Feb. 24 at 10 A. M. to act on his petition, and creditors are notified to appear and show cause, if they have any, why the discharge should not be granted.

Out-of-town jewelers who were here during the past week buying stock included: I. N. Pollack, Ashland, Ky.; William Shire, Paris, Ky.; E. Mueller, Hamilton, O.; J. Heness, Hamilton, O.; Owen Sherwood, Falmouth, Ky.; W. L. Freideking, Hinton, W. Va.; Charles G. Schlenker and wife, Hickman, Ky.; J. D. Ward, Rising Sun, Ind.; C. H. Creighton, Morrow, O.; H. E. Barth, North Vernon, Ind.; H. C. Reed, Blanchester, O.; Mrs. J. H. Drake, Lebanon, O.

The local Manufacturers' Association, organized about two years ago, is renewing its activity and will hold meetings at which subjects of interest to the manufacturer will be discussed. The following are the officers: President, J. C. Miller, of the Miller Jewelry Co.; vice-president, V. A. Gebhardt, of Gebhardt Bros., and secretary-treasurer, E. H. Croninger. These, with Joseph Noterman, of Joseph Noterman & Co.; Arno Dorst, of the Dorst Co.; Samuel Peck, of Peck, Selmeier & Peck, and Mr. Pohlmeier, of Pohlmeier & Roth, constitute the board of directors.

A special meeting of the Cincinnati Retail Jewelers' Association was to have been held last night to take the subject of arrangements for the annual convention of the national association next August. The officers elected at the last meeting are: President, John Bertling; vice-president, William Fink; second vice-president, L. Doruseifer; secretary, Edw. Kaelin; treasurer, George Nagel; membership committee, L. Eisenschmidt, A. Schemel, Ed. Simper, Joseph Kenkel, J. Reinstatler, H. Doepke and George Nagel; grievance committee, Charles Reinstatler, William Fink, Charles Esberger, Sr., and George Fruh.

Denver.

J. C. Bloom returned last week to this city from a business trip to Chicago.

Ed. Jackson, with Syman Bros. Jewelry Co., leaves shortly on a trip to Garden City, Kan.

C. Mantor, formerly with W. W. Bostwick, Longmont, has opened an optical store at Loveland.

F. G. Hayner, Colorado Springs, Colo., was among the out-of-town visitors in this city last week.

J. Starr, formerly of Walsenburg, Colo., has opened a watch repairing shop in room 70, Arapahoe building, 1622 Arapahoe St., where he will do work for the trade only.

James Lewis, of the Lewis Jewelers' Supply Co., left, last week, on an extended trip to the northwest. He will visit Spokane, Seattle and all of the large northwestern cities.

Frank Schroeder, with J. C. Bloom & Co., this city, when asked why he wore the sun-

shine smile last week, laconically replied, "It's a boy." His friends forthwith made the usual informal acceptance of his offer of Havanas.

The jewelry store of O. P. Davis was robbed last week of stock valued at \$2,000, including 43 watches, 20 rings, 36 gold chains and \$50 in cash. The store was entered at the rear door by means of a skeleton key. Davis was attending a lecture while the thieves operated.

A. Loysen, late manager of the Cheyenne Detective Bureau, who was arrested in Walsenburg, Colo., charged with forgery and grand larceny, was brought to Cheyenne, last night. Loysen says he does not remember a thing that occurred after getting drunk in Cheyenne, Jan. 22, until arrested at Walsenburg. His mind, he says, was a complete blank during this period. He claims he did not know he had obtained money and jewelry under false pretenses or had forged papers. Mr. Buechner, of Cheyenne, lost about \$85 in cash and a ring valued at \$125. D. S. Park was also one of the men from whom Loysen got money. Mr. Pott lost a ring valued at about \$65.

Omaha.

TRADE CONDITIONS.

The jewelers of this city report a great demand for diamonds during the past month.

T. L. Combs returned, last week, from an eastern trip.

C. L. Shook, of the Shook Mfg. Co., went to Denver, Colo., on business, last week.

Grover Peterson, with the Sol Bergman Jewelry Co., is making a business trip through the State.

L. P. Watt, formerly with the Mawhinney & Ryan Co., has taken a position with Albert Edholm.

Geo. W. Ryan, of the Mawhinney & Ryan Co., has returned from a trip to New York, Boston and other eastern points.

M. B. Hayden, Turin, Ia., was in the city, last week, calling on old acquaintances and purchasing stock before returning home.

Henry Copley and Abraham Mandelberg narrowly escaped loss by a fire, last week. Fire started on the fourth floor of the Paxton Block, in which building both jewelers are located, and resulted in a \$6,500 loss. Owing to the promptness of the firemen, the fire or water did not reach the first floor.

A well dressed young man entered the offices of several wholesale houses, Wednesday, of last week, and inquired for some employee who in each instance happened to be out. He then informed the clerk who waited on him that the person inquired for had purchased a diamond of him and that he had paid all except from \$1.50 to \$2.50 on it, and that he would like to leave it for him. He then produced the stone and received the money. When it developed that no one in the offices were buying diamonds on the instalment plan and that the stone left was bogus, the men immediately called up the police, but thus far no clue has been obtained to the dealer in glass diamonds.

HEADQUARTERS FOR LATEST AND BEST WATCHMAKERS' AND JEWELERS' SUPPLIES

OUR STRONGHOLDS:
Right Prices, Unsurpassed Service, Orders Accurately Filled, Enormous Stock



The New Oil, "R & L"
We are the selling agents.
Price per bottle, watch or clock, \$0.25
Price per dozen, 2.75

We make a specialty of
BENCHES and CABINETS



Patent Applied For
NEW CASE SCREW WASHERS
D 15. Price per gross, assorted, \$1.75
D 15. Price per doz., separate sizes, .15

Write for our large catalogue, containing 20,000 illustrations. Sent gratis upon application.



ALCOHOL LAMP
D 22. Each, \$0.30

Our Department of **FINDINGS** is the most complete in the country.



Only substance known to produce the black gloss found on new work. All mixed ready for use. 15¢ per bottle, \$0.25

SWARTCHILD & COMPANY

42 East Madison St. (Heyworth Bldg.)
CHICAGO

ESTABLISHED 1887

DUBOIS WATCH CASE CO.



Manufacturers of

Fine Solid Gold Watch Cases



Specialties in Casing of

CHRONOGRAPHS, REPEATERS AND ALL KINDS OF COMPLICATED WATCHES

NEW YORK OFFICE:
21-23 Maiden Lane

FACTORY AND MAIN OFFICE:
316 Herkimer St., Brooklyn, N. Y.

ESTABLISHED 1879



S. BORGZINNER CO.

MANUFACTURERS and IMPORTERS
82 and 84 Nassau St.
NEW YORK



The Perfect Fitting
Case-Screw Washer
AT LAST

CASE-SCREW WASHER An end to shaky watch movements. Will hold the works securely, even when screw shoulder is worn away or case is sprung. Made in sizes 18, 16, 12 and 6. Order direct for present.

Pat. applied for
Gross, \$1.75. Sample dozen, 15¢.
S. URICH, P. O. Box 1942, New York City
Jobbers, wholesalers and material houses write.

Practical Course in Adjusting.

Published Price, \$2.50. Special Reduced Price, \$1.50. All Jobbers, or Jewelers' Circular Publishing Co.

Trade-Marks

of the Jewelry and Kindred Trades. Second Edition. Price, \$3.00. The Jewelers' Circular Publishing Co., 11 John St., New York.

WATCHES OF PRECISION.

Mathey Bros., Mathez & Co.

WATCHES DEMAGNETIZED



Manufacturers and Importers of
Superior, Plain and Complicated Watches.



Sole Agents for

CHAS. H. MEYLAN.

SMALL WATCHES A SPECIALTY.

12 SIZE MOVEMENTS

Brassus, Switzerland

21 MAIDEN LANE, NEW YORK.

12 SIZE SPLITS

Detroit.

J. Bates, New Haven, was a recent buyer in this market.

John Ross, Mt. Clemens, came in on a buying trip, last week.

Hugh Connolly is recovering from a severe attack of the grippe.

R. J. F. Roehm, a veteran jeweler, has been seriously ill with the grippe.

M. C. Graves and wife, Vassar, were among the visitors here, last week.

D. Skutch, with the New Haven Clock Co., visited the trade here last week.

F. Hawley, Brown City, Mich., was a buyer in this market, a few days ago.

H. A. Bliss and Harry Bliss, with the Gorham Co., were in town, last week, in the interest of the concern.

C. H. Patterson, Jackson, was in town recently, laying in new stock for the Spring trade.

W. G. Hamburg, with Wright, Kay & Co., has returned from a week's stay in New York.

George Lester, with the New England Watch Co., made a trip here from Chicago, last week.

R. M. Peare, traveling representative for the Wm. L. Gilbert Clock Co., was in town last week.

John Hellerich has been conducting an auction sale of the stock in his branch store, at 510 Gratiot Ave.

E. W. Krainbrink has started out to cover Ohio and southern Michigan territory for the Chas. A. Berkey Co.

Marvel I. Brabb and Roy C. Brabb, with W. A. Sturgeon & Co., are enjoying a two months' trip to Florida.

Fred N. Pauli, Pontiac, was in Detroit a short time ago, getting material for a fine new cabinet he is installing.

Allison Stone, son of Frank L. Stone, Caro, Mich., is finishing a course in engraving at the M. L. Landis engraving school.

Harry J. Schulz has sold out his store at 395 Grand River Ave., to Stelling B. Lemmon, who has been in business at 85 Broadway.

W. E. Greene, Mt. Clemens, was in this city, visiting the wholesalers, and stated that the trade has been quieter than usual in the Bath City.

Nugent Winstanley, with Tomlinson & Willets, who was married, Jan. 28, to May Chamberlain Warren, returned Friday from a wedding trip to eastern cities.

The show window in LeHeup & Thomas' store, 80 Michigan Ave., was broken by a thief, Sunday night, of last week, and about \$50 worth of cuff buttons and chains was stolen.

Max Jennings, St. Clair, who is a member of the executive board of the National Retail Jewelers' Association, was in Detroit, Friday, on his return from the meeting in Cincinnati.

P. R. Stocker, who has been connected with the Chas. A. Berkey Co., has taken a position with T. J. R. Ayres & Sons, Keokuk, Ia., as manager of the wholesale jewelry department.

George F. Speck, foreman of Burr, Patterson & Co.'s factory, has been seriously ill for 10 days, largely as the result of overwork. He will take a vacation trip as soon as his health permits him to leave the city.

The Jewelers Board of Trade has sent out 5,000 of its catalogues to the trade throughout this section of the country, the idea being to more widely advertise Detroit as a jewelry center.

Daniel Lenton, who has been for more than 10 years connected with the clock department of W. A. Sturgeon & Co., is to take charge of a similar department for T. & E. Dickinson & Co., Buffalo, N. Y., Feb. 21.

W. T. Davies, Jr., who has been in the jewelry business at Alma, has rented his store there, and is moving his stock to this city, where he has secured a location at Grand River and Hudson Aves. He will open up for business on or about March 1.

Several Detroit Jewelry men are going to Cincinnati to take in the bowling championships. Wm. F. Schultz, manufacturer, leads the Herculean team, which won first prize last year. His brother Charles is also a member of that team, and they will bowl in the double and individual championships.

Charles Rice, Belleville, Ont., who retired from the retail business five years ago, after conducting a store on Jefferson Ave. for 22 years, has been in the city visiting his old friends. Ill health was the cause of Mr. Rice's retiring, but as he is now in very much better condition, he expects to re-enter business in a short time.

The marriage of Julius W. Sieler, salesman for the Adolph Enggass Jewelry Co., to Miss Bertha Miller, took place Monday, Feb. 3. Rev. Fr. M. J. P. Dempsey, of SS. Peter and Paul's Cathedral, officiating. Robert Bisch acted as groomsmen, while Miss Bessie Miller was bridesmaid. After a honeymoon spent in the east, Mr. and Mrs. Sieler will be at home at 468 Elwood Ave.

The committee which has been deputed to perfect plans for organizing a retail jewelers' association has been corresponding with the secretaries of local associations in other cities, for information as to their methods of organization, and the measure of success attained in combatting trade evils. It will probably be several weeks before the initial meeting is called to elect officers.

The Bonfield Jewelry Co., 73 Woodward Ave., has purchased the stock of William Ulrich, 322 Gratiot Ave., bidding in the entire equipment, which included safe, show cases, regulator, benches, tools, clocks and a small amount of jewelry, for \$235. The sale, on chattel mortgage, occurred last week, and the very low price is accounted for by the fact that there was little competition in the bidding.

Wholesale jewelers are taking a very active part in the new Wholesalers' Association. William C. Noack, of Noack & Gorenflo, is chairman of the membership committee. Frank M. Kennedy, president of the Jewelers' Board of Trade, has been placed on the trade promotion committee, while Charles A. Berkey is a member of the entertainment committee. The United Jewelry Novelty Co. has recently joined the Wholesalers' Association.

Frank M. Kennedy, of the Kennedy Optical Co.; W. C. Noack, of Noack & Gorenflo, and Chas. A. Berkey, of the Chas. A. Berkey Co., were among the business men

present at the semi-annual banquet of the Wholesalers' Association. By appointing a traffic manager, by buyers' excursions and by judicious advertising, a great deal has been accomplished in the six months the organization has been at work. The next buyers' excursion will take place in three weeks.

Jules Ascheim, New York, has begun proceedings in bankruptcy against Samuel Stern, who formerly conducted a store at 320 Hastings St., and who disappeared in December, most of the assets likewise mysteriously disappearing. A number of the creditors had secured attachments on what remained of the stock, but this new proceeding invalidates these, and it is believed that the claimant's attorney has secured information as to the disposition of some of the missing property. The bankruptcy petition shows a claim of \$2,423.37.

Kansas City.

C. P. Kionka, of Kionka & Kionka, who has been in the city since his return from his eastern trip, will start for Iowa territory, next week, in the interests of his firm.

The Kansas City Polytechnic Institute is overflowing with students. The students, as well as the proprietors, are well pleased with the new quarters on the fourth floor of the Missouri building.

The stock of the Gurney & Ware Jewelry Co. is being sold at auction with a view of closing out the business. The building occupied by the company, as well as that adjoining it on the south, will soon be torn down to make room for a larger and more modern structure.

L. White, representing the Ward & Crellin Jewelry Co., is in after a successful trip in his territory. He is busy filling his trunks and will be on the road again in a few days. Mr. Crellin, of the same firm, will be in town Saturday. After replenishing his trunks, he will return to his territory in Missouri and Kansas.

A. E. Pettenger, proprietor of the Kansas City Horological and Optical School, after two weeks in the hospital, is endeavoring to give his business such attention as the impaired condition of his health will permit. The increase in his business demanding the instalment of two extra benches has made it necessary for him to employ an assistant and he has secured the services of Mr. Hallower, until recently with Gurney & Ware.

The following out-of-town jewelers called on local trade during the past week: Charles Weber, Lexington, Mo.; A. M. Ward, Abilene, Kans.; G. W. Lewis, Herington, Kans.; S. J. Huey, Excelsior Springs, Mo.; Geo. H. Spangle, Chetopa, Kans.; C. E. Wardin and son, Topeka, Kans.; Harry A. Dildine, Kearney, Nebr.; J. H. Leighty, Spring Hill, Kans.; L. D. Bryner, Sparta, Tenn.; H. D. Stone, Brookfield, Mo.; P. J. Zilles, Stanberry, Mo.; J. S. Pieringer, Bedford, Ia.; Geo. Weisgerber, Salina, Kans.; F. E. Pirtle, Council Grove, Kans.; J. Baker, Moline, Kans.

Burnett Bros., Seattle, Aberdeen and Chehalis, Wash., have incorporated their business, with a capital stock of \$150,000.

San Francisco.

J. J. Wilson, Dunsuir, Cal., is visiting this city.

W. R. Landram is expected back from the east this week.

Geo. Smith, agent for the Keystone Watch Case Co., will go east in a few days.

Geo. S. Adams, Sebastopol, Cal., and E. I. Camm, Petaluma, Cal., were in this city last week.

Chas. Young, formerly at 1324 Geary St., has moved to the Native Sons' building, on Gough St.

Wm. Marshall has left the services of the W. K. Vanderslice Co., and is living at San Matco, Cal.

C. F. Mead, with A. I. Hall & Son, is confined to his home by inflammatory rheumatism.

L. Myers, of R. & L. Myers, is receiving congratulations on the occasion of his recent marriage.

H. F. Wichman, Honolulu, H. I., has gone east, and expects to make his home there for some time.

Wm. H. Brown, representing eastern lines on the coast, returned to his San Francisco headquarters Saturday.

Julius Wise, with J. S. Lehrberger & Co., leaves to-day for a pleasure trip to the east, in company with his wife.

Jos. H. Ames, diamond setter, who has been located with A. Eisenberg & Co., has secured an office in the Kamm building.

W. F. Geerds, who has conducted a manufacturing business in Oakland for the past year, has moved his plant to room 706, in the Kamm building.

Walter A. Lord, of the Lord-Cochran Jewelry Co., Goldfield, Nev., paid a short visit to San Francisco, last week, while on his way to southern California.

The Keystone Jewelry Co., on Van Ness Ave., had a narrow escape from fire Monday morning of last week. The fire was caused by crossed wires, and burned a hole in the wall, but prompt action on the part of the fire department saved the store. No stock was lost.

The Morgan & Allen Co. has gotten out a publication that is something unique in the coast trade. It is a neat booklet containing a schedule of the traveling salesmen of the company, with a complete itinerary, showing where each man will be at any time of the year. There is also a complete list of the 27 lines represented.

The Morgan & Allen Co. now represents 17 lines of silverware and clocks, two of cutlery and hardware, and eight of glass ware and lamps. The traveling force is in a general way assigned to departments as follows: Silverware and clocks, A. T. Lipman, W. B. Wood, R. L. Diggs; cutlery and hardware, H. H. Allen, C. C. Brooks, C. R. B. Pierce, W. C. Belli; crockery, glass ware and lamps, E. L. Hine, L. R. Livermore, S. S. Fogarty. C. F. Goddard is in charge of the Denver office.

Visitors to the members of the trade located in the Kamm building, will hereafter be subjected to far less inconvenience than for the last year, as the repairs to that building are now entirely finished, and both elevators are running. Work on the adjoining buildings is also about completed. Many dealers who located there temporarily

after the fire, and expected to go into the Jewelers' building on its completion, find themselves so comfortably situated that they will remain. There are a good many, however, who will go into the new structure, and most of the available space in the Jewelers' building has already been sold.

Los Angeles.

W. A. Walker, Seattle, Wash., was in this city last week.

George L. Dietrich, Anaheim, was here a few days ago, visiting the wholesale trade and supplementing his stock.

Mr. Schwarzkopf, of Schwarzkopf & Peniman, has secured for his firm the agency of the Woodside silver line.

T. W. Copner, foreman of the manufacturing concern of Janes & Co., was ill last week and unable to perform his duties at the company's office.

Another attempt was made to dispose of the Clark jewelry stock at auction a few days ago, but unfavorable weather and other circumstances made manager Berger decide to discontinue the sale.

Ed. Turner, of E. W. Reynolds Co., returned a few days ago from a trip to San Diego and other southern points. He immediately started for a trip to Santa Barbara and other northern cities.

The J. C. Fleming Co. has completed its invoice and reports that sales during January aggregated third in amount as compared with any other months during the last nine in which the firm has occupied its new store.

Montgomery Bros. had in their window last week a display of seven ship's chronometers. These were all sent to them for repair from ships that happen to be in San Pedro harbor. It was the largest number of such chronometers ever brought to the city at one time.

Clem Glass, manager of the H. J. Whitley Co., reports having received a cable message from Mr. Whitley, who is now in Europe, announcing his purchase of a large stock of diamonds. Mrs. Whitley's health has improved and Mr. Whitley expects to return about March 1.

A man named Carbonate Ore Johnson, of Riverside, is under arrest in this city on a charge of using the mails for fraudulent purposes. He is accused of misrepresenting gems which he cut upon orders received through the mails. He is a young man of good family and a number of prominent people are interested in his defense.

The Crown Jewelry Co.'s window, 415 S. Spring St., was broken between 6 and 6.30 A. M. Sunday, Feb. 2, and goods valued at \$323 were stolen. A hole was made in the plate glass large enough for a man to insert his arm and abstract the goods. A policeman who had passed the store less than half an hour before discovered the burglary at 6.30. The goods taken comprise five watches and a number of cases and smaller articles of jewelry. The loss, not only on the goods but on the plate glass, was covered by insurance. Even the lettering on the windows was insured.

J. L. Mullins, Morrisonville, Ill., has sold out to G. Anderson and Guy Freeman, who will take possession about March 1.

Indianapolis.

Samuel Drozdowitz has opened his new retail store at 259 E. Washington St., in this city.

The store of R. T. Green, Syazee, who died several weeks ago, has been purchased by W. A. Petro.

J. P. Reagan, manager of the Baldwin-Miller Co., has been ill at his home in this city for several days.

Members of the Adscript Club elected J. P. Mullally vice-president of their organization for the ensuing year, the election being held Feb. 3.

Oscar Lydegger, Elmer Stokes, and Allen Pickett, employed in George S. Kern's repair shop, in the State Life building, have been ill for several days.

A semi-annual trip to St. Louis is being made by I. Grohs, of the I. Grohs Jewelry Co. He is stopping at the Jefferson Hotel and expects to be away from four to six weeks.

The South Bend Watch Co. is supplying dealers with neat gilt stickers to be used in doing up packages instead of twine. The stickers bear an embossed advertisement of the watch company.

Among out-of-town jewelers in this city, last week, were: F. L. McKee, Cloverdale; J. C. Wilson, Mooresville; E. O. Collins, Franklin; J. W. Hudson, Fortville, and A. W. Owen, Greenwood.

A local newspaper printed a lengthy interview with Carl L. Rost on the diamond situation, one day last week. Mr. Rost stated clearly that the price of diamonds has not been decreased and probably will not be. The interview followed a number of misstatements that have appeared in local papers.

A meeting of the Indianapolis Retail Dealers' Association was held at the Commercial Club, Tuesday evening Feb. 11, to discuss plans for the State convention, which is to be held at the Clayport Hotel here, Feb. 18-19. The local association will be affiliated with the State association at the meeting. Addresses will be delivered by S. R. Miles, President National Retail Hardware Association; R. B. Clark, President Indiana Retail Merchants' Association; A. F. Sheldon, President Sheldon School of Salesmanship, and C. T. Higginbotham, Superintendent South Bend Watch Co.

No clue has been found to the men who broke a plate glass window in Carl Rost's store, on N. Illinois St., in broad daylight Sunday, Feb. 2, and escaped with several hundred dollars' worth of diamonds and jewelry. Mr. Rost has furnished the following list of goods to the police: Twenty-one assorted signet rings, six coral rings, six carbuncle rings, two diamond rings, nine open-faced watches bearing the name "Carl L. Rost," on the dials, two mosaic agate rings, three Amazonite rings, one lion head bracelet, snake design bracelet set with three diamonds, Roman gold bracelet with snake design of coiled wire, one garnet bracelet, a gold bracelet with three diamonds, one Roman gold watch and one amethyst neck chain. A large Roman gold cross, which had been left by a local minister to be sold, was also included among the loot.

INDEX TO ADVERTISEMENTS.

Alvin Mfg. Co.....	Inside Front Cover	Hammel, Riglander & Co.....	34, 106	Potter & Buffinton Co.....	23
American Gem & Pearl Co.....	56	Harris & Harrington.....	94	Price, Cyrus, & Co.....	44
American Platinum Works.....	100	Hedges, A. J., & Co.....	23	Prior, Charles M.....	26
American Watch Case Co.....	93	Hedges, Wm. S., & Co.....	51	Providence Stock Co.....	32
Anderson, P. E., & Co.....	104	Heller, L., & Son.....	46	Prybil, P.....	105
Arizona Turquoise Mines Co.....	24	Herpers Bros.....	98	Racine, Jules, & Co.....	93
Arnstelu Bros. & Co.....	40	Himalaya Mining Co.....	58	Ranlett & Lowell Co.....	94
Arnstine Bros. Co.....	72	Hodenpyl & Walker.....	50	Reichhelm, E. P., & Co.....	98
Aronson & Spiegel.....	61	Hoffman Novelty Co.....	33	Reichman, A.....	58
Austin, John, & Son.....	98	Hold-On Clutch Co.....	26	Renziehausen, W. F., & Co.....	104
Bagg, Perlue & Co.....	52	Hotel St. James.....	100	Revell, A. H., & Co.....	102
Baker, Geo. M.....	102	Howard, E., Clock Co.....	94	Rice's, Bernard, Sons.....	102
Ball, Webb C., Watch Co.....	90	Hraha, Louis W.....	102	Richards, J. M.....	48
Bassett Jewelry Co.....	30	Illinois Watch Co.....	70	Richardson, Enos, & Co.....	20
Bastian Bros. & Co.....	14	Irons, Joseph.....	32	Robbins, Chas. M., Co.....	29
Bates & Bacon.....	16	Irving Cut Glass Co.....	100	Robert, E. E.....	92
Berge, J. & H.....	104	Jacot Music Box Co.....	100	Rockford Watch Co.....	61
Blaney, S. O., & Co.....	6	Jantschek Co.....	98	Roger Williams Silver Co.....	30
Billings, Chester, & Son.....	50	Jeanue, F. A.....	48	Rohrbeck, John E.....	25
Bippart, Grlscom & Osborn.....	22	Juergensen, Jules.....	95	Roseman, A.....	56
Bishop, R. W.....	26	Juzek, T. J., & Co.....	94	Roy Watch Case Co.....	94
Blackinton, R., & Co.....	12	Kahn, L. & M., & Co.....	40	Rudolph & Suedeker.....	95
Borgzinner, S., Co.....	74	Keck, Herman, Mfg. Co.....	42	Rumpp, C. F., & Sons.....	80
Borrelli & Vitelli.....	48	Keller Jewelry Mfg. Co.....	22	Saunders, Meurer & Co.....	54
Bowden, J. B., & Co.....	25	Kelly & Steinman.....	100	Schlickerling Mfg. Co.....	60
Bradley Polytechnic Institute.....	27	Kent & Woodland.....	24	Schultz & Co., Inc.....	26
Bristol Mfg. Co.....	6	Ketcham & McDougall.....	32	Sessions Clock Co.....	94
Bryant, M. B., & Co.....	25	Keystone Watch Case Co.....	88	Smith, Alfred H., & Co.....	46
Byrnes, Townseud & Swenarton.....	80	Kirby, H. A.....	64	Smith, C. Sydney, Co.....	61
Carter, Howe & Co.....	21	Kohlbusch, Herman, Sr.....	26	Smith, Frank W., Co.....	34
Chatham National Bank.....	68	Kohn, Alois, & Co.....	22	Snow & Westcott.....	24
Chicago Art Metal Works.....	26	Kollmar, Rauch & Co.....	25	Sohn & Hyman.....	58
Chopard Frères.....	27	Kremenz & Co.....	19	Solidarity Watch Case Co.....	11
Cohen, J. J.....	48	Langendorf Watch Co.....	92	Spencer, E. L., Co.....	29
Cooper & Forman.....	23	Larter & Sons.....	38	Star Watch Case Co.....	8
Cottle, S., Co.....	21	Lederer, S. & B., Co.....	28	State Bank.....	66
Crees & Court.....	98	Lees & Sanders.....	104	Steiner, Louis.....	31
Crohn, M.....	29	Lelong, L., & Bro.....	98	Stern Bros. & Co.....	56, Inside back cover
Cross & Beguelin.....	18, 64	Lewy & Cohen.....	24	Sternau, S., & Co.....	14
Crossman Co.....	46	Lisner, D., & Co.....	18	St. Louis Watchmaking School.....	94
Crouch & Fitzgerald.....	102	Lissauer & Co.....	58	Street, Geo. O., & Sons.....	21
Day, Clark & Co.....	23	Lorsch, Albert, & Co.....	40	Sussfeld, Lorsch & Co.....	102
Deacon, Louis J.....	21	Loth, Joseph, & Co.....	80	Swartchild & Co.....	74
Doran, Bagnall & Co.....	29	Lowe, Edwin, & Co., Inc.....	29	Tiffany Electric Mfg. Co.....	95
Dorflinger, C., & Sons.....	100	Malatien Bros. & Elliot.....	31	Title Guarantee & Trust Co.....	66
Draper, O. M., Estate.....	15	Market & Fulton National Bank.....	66	Trout, Charles L., & Co.....	27
Dubois Watch Case Co.....	74	Mathey Bros., Mathez Co.....	74	Unique Art Glass & Metal Co.....	61
Dueber-Hampden Watch Mfg. Co.....	10	Mercantile National Bank.....	67	Untermeyer-Robbins Co.....	60
Dunn, T. J., Co.....	25	Meyerowitz Bros.....	42	Urich, S.....	74
Durand & Co.....	20	Miller, Fuller & Whiting Co.....	31	U. S. Smelting & Refining Works.....	104
Eichberg & Co.....	58	Miller, L. A.....	26	Vacheron & Constantin.....	92
Eisenmann Bros.....	50	Morstrom, W. G.....	58	Van Dam, Eduard.....	42
Elgin National Watch Co.....	86	Mount & Woodhull.....	52	Van Dusen & Stokes Co.....	24
E. P. H. Chain Catch.....	30	Myers, S. F., Co.....	30	Wachter Mfg. Co.....	95
Fahys, Joseph, & Co.....	3	Nassau Bank.....	66	Wadsworth Watch Case Co.....	9
Feldenheimer, Louis.....	58	New England Watch Co.....	91	Wagner Comb Mfg. Co.....	27
Forman Co.....	100	New York Jewelry Purchasing Co.....	22	Waite-Thresher Co.....	33
Foster, Theodore W., & Bro. Co.....	36	Nissen, Ludwig & Co.....	52	Waltham Watch Co.....	84
Freeman, B. S., Co.....	28	Noel, Rudolph, & Co.....	46	Washburn, C. Irving.....	27
Freund, Henry, & Bro.....	17	Omega Watches.....	93	Wells, Chester H.....	27
Galaway, J. H. & F. H.....	98	Oneida Community, Ltd.....	Outside back cover	Wendell & Co.....	7
Garreaud & Griser.....	21	Oppenheimer Bros. & Veith.....	42	Wheeler, Hayden W., & Co.....	48
Gillette Sales Co.....	35	Oskamp-Nolting & Co.....	33	Whiting & Davis.....	17
Goodfriend Bros.....	54	Osmers-Dougherty Co.....	24	Whiting Mfg. Co.....	13
Gorham Co.....	62	Osmun-Parker Mfg. Co.....	20	Wightman & Hough Co.....	30
Grabemann, Herman.....	95	Ostby & Barton Co.....	16	Wodiska, Julius.....	27
Greene, Wm. C., Co.....	32	Pairpoint Corporation.....	100	Wollstein, L. & M.....	104
Griffoul, August.....	104	Papazien, A. D.....	94	Wood, Chas. F., & Co.....	50
Gugenheim, M.....	31	Patek, Philippe & Co.....	92	Wood, J. R., & Sons.....	4, 5
Hagstoz, T. B., Ltd.....	104	Penfold, Wm. C., Co.....	91	Zaremhowitz, A.....	98
				Zimmern, Henry, & Co.....	105

Special Notices.

Payable invariably in advance.
 Rates 75c. per insertion for notices not exceeding 25 words; additional words, 2c. each.
SITUATIONS WANTED, 1c. a word each insertion; minimum charge, 25c.
Heavy type, 5c. a word; minimum charge, \$1.25.
 Display cards, \$2.00 per inch.
 In all cases, if answers are to be forwarded, 10c. extra to cover postage must be enclosed.

All answers to advertisements addressed care The Jewelers' Circular-Weekly, should be sent to the New York Office, unless the Chicago Office is specifically mentioned.

Situations Wanted.

WATCHMAKER and jeweler; four years' experience; A1 reference. Address R. L. Winchest, Phillips, Wis.

JEWELER, expert, desires position; has been with Stern Bros. & Co. nine years. L. Posner, 117 Ellery St., Brooklyn, N. Y.

JEWELER and goldsmith, German, experienced in all branches, desires position. Address "G., 3295," care Jewelers' Circular-Weekly.

JEWELER, Spaniard, first class practice on platinum work, wishes steady position; modest salary. F. Gil, 3 President St., Brooklyn, N. Y.

WATCHMAKER, thoroughly practical, with 20 years' experience; first class references. Address "P., 3331," care Jewelers' Circular-Weekly.

YOUNG MAN, 20, experienced, desires position in wholesale jewelry house; references. Address "W., 3246," care Jewelers' Circular-Weekly.

ENGRAVER, married, desires steady position; can do clock work and some jewelry repairing. Address "E. W.," 114 S. 7th St., Vincennes, Ind.

WATCHMAKER wants position; experienced on Swiss and American watches, with complete set of tools. Ed. Herzberg, 402 E. 79th St., New York.

YOUNG MAN, 25, desires position with wholesale house; eight years' experience in office and factory. C. G. Braxmar, Jr., 352 W. 32d St., New York.

DIAMOND SETTER, all around man, can do ring sizing, wants position; good references. Address Max Diement, 382 Jackson Boulevard, Chicago, Ill.

SALESMAN, seven years with present house, selling mountings, city and out-of-town, desires change. Address "W., 3332," care Jewelers' Circular-Weekly.

YOUNG MAN wishes position as salesman, order or stock clerk in wholesale, retail jewelry or silver house. Address "X., 3072," care Jewelers' Circular-Weekly.

PLATER, colorer and etcher, experienced on jewelry, silver and metal novelties, desires steady position. Address "IL, 3208," care Jewelers' Circular-Weekly.

JEWELER, young man, eight years' experience, wishes position as jeweler or learn watchmaking and engraving. Address "Carlson," 240 E. 25th St., New York.

POSITION WANTED by young man, 27, married, who is experienced in watch, clock, jewelry repairing and engraving. Address P. O. Box 445, Marion, O.

JEWELER wants position on special order and general line of good work, also repairs in store or first class factory. Address "C., 3276," care Jewelers' Circular-Weekly.

FIRST CLASS watchmaker, with tools, desires position at once; middle age man; competent to handle railroad work. Address "E. H. B.," 45 Charles St., Springfield, Mass.

WATCHMAKER, 12 years' experience in retail store, can do plain engraving; salary \$18; only first class stores considered. Address "R., 3318," care Jewelers' Circular-Weekly.

ENGRAVER, monograms, inscriptions, etc., on silverware and jewelry; good workman; 15 years' experience; New York City only. "R., 3176," care Jewelers' Circular-Weekly.

SILVER SALESMAN, 10 years' experience, desires to connect with first class retail house; can furnish best of references. Address "J., 3302," care Jewelers' Circular-Weekly.

PERMANENT POSITION by young man, first class watchmaker, jeweler and monogram engraver; married. Address W. L. Primrose, 125 S. 7th St., Grand Junction, Colo.

YOUNG MAN, 23, wants position as assistant watchmaker; four years' experience on watch, clock and jewelry repairing; best references. Address F. Berger, Newark, N. Y.

A THOROUGHLY competent jeweler desires position in New York City or country; A1 references furnished if desired; wages moderate. Box 3278, care Jewelers' Circular-Weekly.

EXPERIENCED WATCHMAKER and engraver would like steady position in first class store; desires a change; east preferred. Address "C., 3268," care Jewelers' Circular-Weekly.

POSITION WANTED by first class watchmaker, competent in every detail; complete line of tools; able to take charge of department. Address "I., 3312," care Jewelers' Circular-Weekly.

WATCHMAKER, up-to-date engraver, used to doing artistic monogram work; long years' experience in the jewelry business. Address "W. E. C.," 7417 Linwood Ave., Cleveland, O.

A FIRST CLASS watchmaker, 22 years' old, wants a position at once; speaks German only; experienced in high grade work. Address "I. R., 3219," care Jewelers' Circular-Weekly.

YOUNG LADY desires position with jewelry house; have experience with stock and general office work, also stenographer and typewriter. "K., 3279," care Jewelers' Circular-Weekly.

WANTED, POSITION as saleslady in first class retail jewelry store; 17 years' experience; can furnish best reference. Address Miss C. L. Gauslin, J. Juneau Court, Milwaukee, Wis.

YOUNG MAN, 21, having almost five years' experience with diamond importing house, desires to make a change; can furnish best of references. "R., 2906," care Jewelers' Circular-Weekly.

YOUNG MAN, 25, does watchwork and plain engraving, desires position under good watchmaker; middle west or south preferred; own tools. Address "X., 3335," care Jewelers' Circular-Weekly.

MANUFACTURER'S LINE wanted for jobbing, department store and retail trade for New York City and vicinity; can furnish highest references. Address "B., 3311," care Jewelers' Circular-Weekly.

A THOROUGHLY reliable young man, having 10 years' experience with diamonds and knowing something of the jewelry business, desires position. Address "U., 3321," care Jewelers' Circular-Weekly.

RETAIL SALESMAN, with 10 years' experience, desires position with an A1 New York City store; thoroughly understands the business; best of references. Address "B., 3325," care Jewelers' Circular-Weekly.

YOUNG MAN, 23 years, having seven years' experience in wholesale jewelry house, desires position of any kind, salesman, shipping clerk or order clerk. Address "O., 3313," care Jewelers' Circular-Weekly.

YOUNG MAN, first class engraver, good salesman and assistant watchmaker, six years' experience, nice appearance, best references, wishes to finish watch work under good man. "Y., 3336," care Jewelers' Circular-Weekly.

SALESMAN, calling on New York City and out-of-town trade, desires change with A1 jobbing or manufacturing house; seven years' experience; highest references. Address "R., 3021," care Jewelers' Circular-Weekly.

WANTED, manufacturer's line of filled jewelry, silver or plated toilet or flat ware on commission; established trade in New York, Philadelphia, Baltimore and middle west. Eric R. Sheppard, 53 Maiden Lane, New York.

ENGRAVER, A1, now head engraver for highest class jewelry firm in Pittsburg, Pa., wishes to make a change; distance no objection; married; total abstainer; best references. "S., 3211," care Jewelers' Circular-Weekly.

REFRACTIONIST and watchmaker of ability expert in retinoscopy, practical adjuster and moulder; good salesman to locate with good house south or middle south. Address "Z., 2779," care Jewelers' Circular-Weekly.

DESIGNER, artistic, experience with all branches of jewelry, thorough modeler, die cutter and cbsar, capable to manage men and take charge wants engagement with best firm only. "B 3323," care Jewelers' Circular-Weekly.

BOOKKEEPER, cashier and office manager open for engagement; 15 years' experience thoroughly competent in all details; knowledge of factory payrolls; A1 references. Address "B 3238," care Jewelers' Circular-Weekly.

YOUNG MAN, with three years' experience wishes to finish trade under competent watchmaker; can do jewelry repairing, clock and plain watch work; can give good reference. C. Va Deusen, 5 6th St., Gloversville, N. Y.

POSITION WANTED by an A1 salesman for big class retail store; diamonds, watches, jewelry etc.; 20 years' experience; honest, reliable and trustworthy; references upon application. "Hor est, 3270," care Jewelers' Circular-Weekly.

A FIRST CLASS watchmaker, 25 years' experience on big grade American and Swiss watches, wishes a steady position; can start at once in vicinity of New York City. Address "K., 3228," care Jewelers' Circular-Weekly.

YOUNG MAN, 19, former pawnbrokers' clerk having acquired thorough knowledge of the jewelry business, desires a position with a jewelry firm; thoroughly competent; best of references furnished. T. Edelstein, 235 E. 4th St., New York.

POSITION WANTED by a young man, a practical watchmaker, jeweler and salesman, with good firm in New York or Brooklyn, to take charge of repairing department and sale of watches. "M., 3324," care Jewelers' Circular-Weekly.

FIRST CLASS watchmaker on railroad work, experienced in both store and factory, desires position as head watchmaker at once; good appearance and best of references; please state wage. Address "J. W., 3292," care Jewelers' Circular-Weekly.

FIRST CLASS REFRACTIONIST, 20 years' experience, A1 adjuster and fitter, good salesman, good address, at present employed as manager, desires change; very best references; want on a first class position. Address "Competent, 3284," care Jewelers' Circular-Weekly.

YOUNG MAN, age 22, desires a steady position with good, reliable firm; watchmaker, good engraver window dresser; speaks German and English can wait on trade if necessary; can furnish references; state particulars in first letter. Wm. I. Boxman, 21 N. Main St., Kokomo, Ind.

ENGRAVER; young man, good engraver, buff and salesman, who has done some hard soldering and clock work and is willing to be general useful around store and shop, would like position with reliable firm; best references. Address "B., 3195," care Jewelers' Circular-Weekly.

FIRST CLASS letter and monogram engraver, young man of good appearance, four years' practical experience, engraving and waiting on trade, desires good, steady position in jewelry store; references and samples upon request. Address "S. T., 3297," care Jewelers' Circular-Weekly.

YOUNG MAN, of good address, desires a house position with good retail, wholesale or manufacturing concern; has had four years' road experience, prior to this spent six years at the manufacturing business, at present representing one of the leading New York jobbers in the east and middle west. "R., 3291," care Jewelers' Circular-Weekly.

Help Wanted.

WANTED, optician and engraver; only experienced, well recommended man. Chas. S. Stitt, Little Rock, Ark.

WANTED, first class watchmaker and engraver must be a good mechanic. S. Joseph & Son, 400 Walnut St., Des Moines, Ia.

WANTED, a thorough clock repairer, one who can do light jewelry repairing; state salary and reference. Klee & Groh, Rochester, N. Y.

WANTED, at once, first class manufacturing jewelry clerk; good salary, steady position; give references. Tobin & Canham, Springfield, Ill.

HELP WANTED.—Continued.

WANTED, an experienced workman, who can do good watch work and nice engraving; good salary. Address J. S. Baird, Watertown, N. Y.

FIRST CLASS watchmaker; permanent position, good salary; first class reference required. Address "V., 3329," care Jewelers' Circular-Weekly.

WANTED, first class watchmaker and jeweler; permanent position; state references, wages, etc., in first letter. Address "S., 3137," care Jewelers' Circular-Weekly.

SALESMAN to carry select line of diamond mountings as side line on commission, New York and vicinity. Address "V., 3303," care Jewelers' Circular-Weekly.

WANTED, first class watchmaker and optician; permanent position to right party; state wages desired, references, etc. Address H. Mahler's Sons, Raleigh, N. C.

WANTED, watchmaker and engraver; permanent position; \$25 per week; send reference and sample of engraving in first letter. S. J. Rivoire, 131 S. Grand St., Monroe, La.

WANTED, at once, assistant watchmaker, clock and jewelry repairer, engraver, who can wait on trade, permanent position. H. W. Wood, 35 Merrimack St., Haverhill, Mass.

WANTED, first class watchmaker; permanent position to experienced man; apply by letter. Address "Watchmaker," care the Bailey, Banks & Biddle Co., 1213 Chestnut St., Philadelphia, Pa.

WANTED, competent salesman on commission basis in every State; no objection to side lines. Inquire Empire Jewelry Case Co., manufacturers of the patented Empire jewel cases, Buffalo, N. Y.

WANTED, first class jeweler, who is an all around workman in both new and repair work and stone setting; permanent position; state references, wages, etc. Address H. Mahler's Sons, Raleigh, N. C.

GOOD ENGRAVER and jeweler wanted, at once; permanent position; one who can do some watch and clock repairs preferred; Georgia city of 20,000 population. "A., 3204," care Jewelers' Circular-Weekly.

WATCHMAKER, jeweler and plain engraver; state reference, experience and salary wanted; permanent position; it's 40 miles from New York City, on the water. Address "Z., 3109," care Jewelers' Circular-Weekly.

THREE thoroughly competent watch salesmen, for high class New York retail store; must have good appearance and first class reference; state full particulars and salary wanted. Address Box 3200, care Jewelers' Circular-Weekly.

WANTED, salesman visiting the jobbing trade in New York City regularly, to carry a small but staple and salable side line on commission; only a persistent hustler with good references need apply. Address "Reliable, 3125," care Jewelers' Circular-Weekly.

WATCHMAKER and jewelry repairer who can translate from French and German into English, and who knows something about the theory of horology, will be offered desirable position; state age, nationality, education, general qualifications, etc. "R. J., 2314," care Jewelers' Circular-Weekly.

WANTED, experienced jewelry salesman who has made a specialty of gold brooches and scarf pins, to handle a manufacturer's line to the jobbing trade; an excellent opportunity is offered to one who is thoroughly familiar with this line and can command trade; parties not having such experience need not apply. Box 3101, care Jewelers' Circular-Weekly.

Business Opportunities.

\$2,500 WILL BUY stock and fixtures of modern jewelry store in manufacturing town of 14,000 inhabitants in Ohio. Address "Good Opportunity, 3126," care Jewelers' Circular-Weekly.

A RING FACTORY, doing fine work, and well equipped; a close price will be considered for cash offer; write if interested. Address "N., 3290," care Jewelers' Circular-Weekly.

\$5,000 WILL BUY jewelry store, averaging \$13,000 cash sales per year; clean stock; good run of hench work; central west. Address "Z., 3215," care Jewelers' Circular-Weekly.

WILL PURCHASE, for spot cash, jewelry, silverware, clocks, etc., also jewelry and silverware lined boxes new or second hand. Sterling Jewelry Co., 54 W. 34th St., New York.

FINE LOCATION, western Iowa, 1,000 inhabitants, owner 15 years at same stand, wants to retire; small cash payment with good references can buy. Inquire the A. F. Smith Co., Omaha, Nebr.

FINE BUSINESS for sale owing to ill health; will sell at very low price; done a very heavy business this Christmas; price, \$7,000; will rent store also. W. H. Van Keuren, 367 Main St., Poughkeepsie, N. Y.

JEWELRY FACTORY, with all machinery running by electricity, in best location of Brooklyn, with stores and private trade; have to sell on account of leaving town. "Chance, 3327," care Jewelers' Circular-Weekly.

MANUFACTURING jewelry and silversmith's business, large quantity of souvenir spoon dies, drops, presses, roller and lathes, thoroughly equipped and well established trade throughout the west and south, especially California; entire plant and good will, \$5,000. "Particulars," Box 629, Denver, Colo.

A FIRST CLASS, well conducted jewelry store for sale, on account of desiring to retire; cheap lease; will reduce stock to \$3,000; entire fixtures and lease, \$1,000; don't lose this chance, or will be compelled to sell the entire stock, good will and lease at auction on April 1 to the trade. M. Hodcs, 2168 Third Ave., New York.

FOR SALE, a nice retail jewelry and souvenir business, located on Penn. Ave., Washington, D. C.; stock over \$10,000; will reduce if desired; sale at inventory price or less if purchased outright; owner unable to give the business his personal attention, being disabled. Address "S., 3326," care Jewelers' Circular-Weekly.

AT 50 CENTS on the dollar and less, corals, jets, ambers, plated and gold filled jewelry, solid gold baby pins, chains, etc., also a lot of diamond jewelry bought at trade auction sales; sent on memo. bills to well rated jewelers; sold for cash only. Address Dan I. Murray, broker and leading auctioneer of America, 3 Maiden Lane, New York.

OLD ESTABLISHED jewelry business, 22 years, for sale, cheap for cash; first class trade and repairing; Christmas trade runs to \$4,000; retiring on account of old age; three years' lease. A. D. Ernne, 21 Colonial Arcade, Cleveland, O.

FOR SALE, well established jewelry and optical business in town of 6,000 in new State of Oklahoma; county seat and mining town; monthly payroll, \$80,000; does \$6,000 cash business per year; nice clean, up-to-date stock of \$6,000; can be reduced to suit purchaser; reason for selling explained on request; don't let this chance go by. Address "D., 3210," care Jewelers' Circular-Weekly.

FOR SALE, a complete jewelry factory, formerly Eisler & Laubheim's shop, at 87 Maiden Lane; large and light; modern machinery, models, dies, safes and fixtures; includes lease; all at very reasonable price; splendid opportunity. "A. S.," Room 55, 65 Nassau St., New York.

LEADING jewelry business in one of the best towns on Puget Sound; population, 25,000; 1907 business, \$23,500; stock invoices \$17,000; fixtures, \$2,000; railroad watch inspector; can reduce stock to \$10,000; terms one-half cash, balance bankable paper; repair work, \$225 a month; net profits in two years, \$6,000; unless you mean business don't write me; other business interests demand my attention reason for selling. "Puget Sound, 3320," care Jewelers' Circular-Weekly, 42 E. Madison St., Chicago, Ill.

DO YOU WISH TO RETIRE? Why not turn your entire store or surplus stock into cash? We pay the highest prices, also advance liberal cash amounts on stocks; communicate with us before consulting others; we act quick and strictly confidential. Brooklyn Purchasing Syndicate, 608 Broadway, Brooklyn, N. Y., Telephone, 2328 Williamsburg.

CHANGE YOUR LOCATION and bring your own stock; would you change your location, \$17,000 business in 1907, one that you can move your present stock into and step into a new store room with a business already built making money in an Iowa town? If you have an \$8,000 stock or over correspond with us; if not, don't reply, as your stock would not take the place and be the leading firm; the store is in the best location; the best optical, jewelry and music business in the county; we want to rent building, sell material and part of fixtures; reduce stock to suit purchaser; answer quick. Address Mrs. J. Moir, cor. Moss and Barker Aves., Peoria, Ill.

For Sale.

FOR SALE, jeweler's safe, inside dimensions, 24 x 27 x 30. Ford & Carpenter, 2 Maiden Lane, New York.

FOR SALE, reducing machine for dies, electric motor and appliances. Brenner, 624 Madison Ave., New York.

FOR SALE, jewelers' flat rolling mills, with stand, good order. C. Wild, care Guerber Bros., 10 John St., New York.

FOR SALE, a fine eight day English chronometer, very cheap. Address Holler Watch Co., 150 Broadway, Brooklyn, N. Y.

FOR SALE, six semi-circular solid mahogany wall cases, marble base, fine brass trimmings, five years old, bought from the Mitchell Furniture Co., Cincinnati, O.; will sell cheap. L. Vilsack & Co., Pittsburg, Pa.

JEWELER'S wall show case, 10 ft. long, eight ft. high, two ft. deep, three sliding windows, perfect order; table, 10 ft. long, leather covered, solid mahogany; chairs, desk, various tables; cheap; changing business. Room 11, 23 Union Sq., New York.

To Let.

TO LET, half of store with show window and large basement, 16 John St., New York; inquire within.

SMALL, light office in Cockcroft Building. Apply Myers & Gordon, Room 1301, 71-73 Nassau St., New York.

TO LET, part of fine light diamond office, moderate rent, for manufacturer's representative. Room 1308, 9-13 Maiden Lane, New York.

FIREPROOF LOFTS, reinforced concrete building, eight minutes from Maiden Lane, 150 feet from subway station, 41 x 95; elevator and heat. Address owner, Van Nostrand, 118 Chambers St., New York.

FOR RENT, repair shop in New York City for jobbing jeweler; dynamo and complete fixtures already installed; excellent location and good opportunity for practical man. "Repair, 3111," care Jewelers' Circular-Weekly.

TWO large, light, outside rooms in Reed & Barton Building, 320 Fifth Ave., apply H. F. Taylor, Room 302, 320 Fifth Ave., New York.

Wanted to Purchase.

WANTED TO BUY, watchmaker's American lathe, mill drill and other tools. Address "P., 3316," care Jewelers' Circular-Weekly.

Trade-Marks of the Jewelry and Kindred Trades. Second Edition. Price, \$3.00. The Jewelers' Circular Publishing Co.

Trade-Marks

of the JEWELRY *and*
KINDRED TRADES

SECOND EDITION
OVER 4000 MARKS

Price, \$3.00

THE JEWELERS' CIRCULAR PUB. CO.

11 John Street, NEW YORK

LEATHER WATCH BRACELETS



Send for assortment on Display Card

ESTABLISHED
1850

C. F. RUMPP & SONS

TRADE  MARK

Manufacturers of FANCY LEATHER WARE

PHILADELPHIA

New York Salesrooms, 683 and 685 Broadway

== R I B B O N S ==

plain and fancy designs **Made to Order**,
in large or small quantities, to use with medals and
for club purposes. :: :: :: Correspondence invited.

JOSEPH LOTH & CO., Manufacturers, 65 Greene Street, New York

RECENTLY
PUBLISHED

READY FOR
DELIVERY

Gems and Precious Stones

THEIR

Characteristics, Localities of Production, Tests and Some Current Literature.

A new book on a new plan. Tabulated, concise, authoritative.

A handy manual for every Jeweler.

CONTENTS

CHARACTERISTICS and LOCALITIES of PRECIOUS STONES

Shows in tabulated form the Chemical Composition, Crystallography, Common Fracture, Lustre, Hardness, Color, etc.

TESTS FOR PRECIOUS STONES:

Describes testing implements, methods of testing, mineralogical characteristics, specific gravity, dichroism, tests, etc.

FAMOUS DIAMONDS OF THE WORLD.

SOME FAMOUS DIAMONDS.

BIRTH STONES OF VARIOUS NATIONS.

GEMS FOR THE DAYS OF THE WEEK.

POETRY OF GEMS.

BIRTH STONES AND THEIR SIGNIFICANCE.

SIGNIFICANCE OF SOME GEMS.

BIRTHDAY FLOWERS.

ZODIACAL SIGNS OF FLOWERS.

WEDDING ANNIVERSARIES.

FLOWERS OF THE MONTH.

OFFICIAL FLOWERS OF THE UNITED STATES.

CLOTH, POSTPAID, \$1.00

PUBLISHED BY

**The Jewelers' Circular
Publishing Co.**

11 John Street New York

**Byrnes, Townsend & Swenarton
Patent Lawyers**

(Ex-Examiners U. S. Patent Office)
277 Broadway New York
Patents Trade-Marks

PATENT DEPARTMENT



IN WHICH IS CONTAINED A LIST OF THE LATEST PATENTS GRANTED BY THE UNITED STATES AND GREAT BRITAIN, THE UNITED STATES PATENTS THAT HAVE EXPIRED AND THE REGISTERED TRADE-MARKS.

UNITED STATES PATENTS.

ISSUED FEB. 4, 1908.

878,011. PIN AND THE LIKE. FRANK H. NOBLE, Chicago. Filed Aug. 1, 1904. Serial No. 219,044.

In a device of the class described, the combination with a fastening pin having an enlarged spherical end of a bifurcated clock forming a base

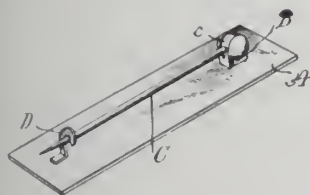

pedestal adapted to be secured at its bottom end to the body of the device, the two divisions of said block supporting two substantially hemispherical socket portions integral with such divisions and which co-operates to form a spherical socket adapted to receive the enlarged spherical end of the pin.

878,076. CLOCK AND WATCH. JULIUS LICHTENSTEIN, Göttingen, Germany. Filed July 8, 1907. Serial No. 382,753.

A safety contrivance for the springs of clocks and watches, comprising in combination with the clock spring, its winding-up bolt, and base disk; a lower sleeve (*f*) arranged in said clock spring, and an upper sleeve (*e*) arranged above said clock spring on said bolt and provided with a notch (*e'*),

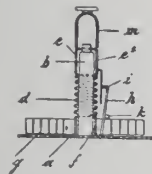

a separate spiral spring arranged on said bolt between said sleeves, a key (*m*) designed to fit said bolt, a movable pin (*h, i*) designed to catch into the notch in said upper sleeve, a lateral rod (*k*) projecting from said pin, and a projection (*l*) provided on said clock spring and adapted to engage said rod and thus to cause said pin to leave said notch in said upper sleeve upon the clock spring being sufficiently wound up, for the purpose set forth.

878,087. ELECTRIC ALARM OPERATED BY ALARM-CLOCKS. EDWARD PLOUDRE, St. Louis, Mo. Filed March 20, 1907. Serial No. 363,445.

The combination with an alarm clock of a vertical metallic post having two perforated projections upon it, one perforated projection near each end; an armed metallic rod adapted to close a circuit by being forced down through the said perforated projections by a spring, the arm of the metallic rod adapted to be placed on the top of the alarm stem of the clock and released when the alarm of the clock is set free; a spring connected at one end to the upper perforated projection of the vertical metallic post and the other end connected to the armed metallic rod, adapted to force the armed metallic rod down and in contact with one of the terminals of an electric circuit; and an

electric circuit including a source of electricity, an incandescent light, an electric bell, and a circuit closing switch between the electric bell and the source of electricity, all electrically connected, the

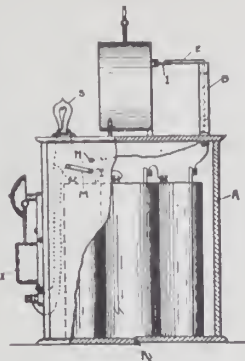

terminals of which circuit are closed by the armed metallic rod descending.

878,122. JEWELER'S CHAIN AND BEAD STOCK. JOHN COSTELLO, Providence, R. I. Filed July 30, 1907. Serial No. 386,264.

A chain bead stock comprising a chain, a series

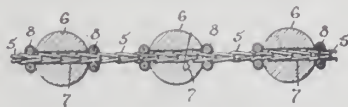

of spaced beads on the chain and a ring secured on the chain at each side of a bead

878,220. STEM-WINDING WATCH. ROBERT MANTHEY, Jersey City, N. J. Filed April 5, 1907. Serial No. 366,538.

In a watch, the combination with the front



plate which furnishes bearings for the train works, of a block or bridge piece secured thereto and a pendant made integral with the said block or bridge piece.

878,251. ALARM-CLOCK. ELMER E. STOCKTON and ARTHUR H. PORTER, Bristol, Conn., assignors to the E. Ingraham Co., Bristol, Conn. Filed May 27, 1907. Serial No. 376,011.

In an alarm-clock, the combination with a circular case-body the rear portion of which is pierced to form sound holes, of a case-back adapted to be inserted into the open rear end of the said case-body, a movement-frame located

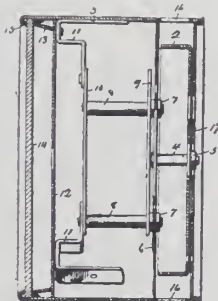

within the said case-body, a dust-guard located between the said movement-frame and the said sound holes, and a flanged sheet-metal bell arranged concentrically within the rear portion of the case-body and located between the said dust-guard and

case-back, whereby the bell is located inside instead of outside of the case-body and so protected thereby.

878,346. WATCHMAKER'S HAIRSPRING GAGE. ELIJAH CLARK, Alameda, Cal., assignor to Joseph Nordman, San Francisco, Cal. Filed April 19, 1907. Serial No. 369,164.

A watchmaker's hairspring gage comprising a scale, a support therefor, a spiral hairspring having one end attached to the support, and extensible



from said point of attachment along the scale, means for temporarily attaching to the remaining end of the said spring the hairspring to be tested, and an indicating device on the said spiral spring for marking on the scale the movement of the said spring under extension.

878,371. ALARM-CLOCK. EDWARD E. GAGE, New York. Filed March 15, 1907. Serial No. 362,443.

An alarm-clock provided with a supplemental alarm set dial, and means whereby the alarm may be set to operate at any hour or fractional parts thereof, and supplemental alarm set devices whereby the alarm may be set to operate at any minute of the day or night, comprising an annular rotary minute dial mounted on and inclosing the hour dial of the clock, a supplemental arbor slidably mounted on and rotatable on the minute arbor and on which the hour arbor is mounted, said supplemental arbor being provided on its inner side with a tooth adapted to enter a recess in the minute gear, a spring lever pivoted to the frame

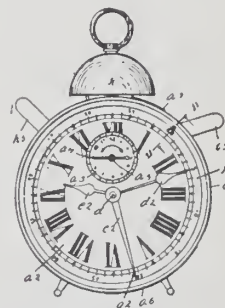

of the clock mechanism and provided with an aperture through which the supplemental arbor passes, said spring lever being passed out through the casing of the clock and adapted to be operated by hand, and an operating hand connected with the supplemental arbor and adapted during its rotation to engage and carry with it the annular minute dial and to be automatically released therefrom at a predetermined time, said spring lever being also adapted to engage a trigger connected with the escapement shaft with which the hammer of the alarm device is also connected.

878,374. COFFEE OR TEA PERCOLATOR. FRIEDRICH GEISSLER, Klotsche, near Dresden, Germany. Filed June 15, 1906. Serial No. 321,929.

In a coffee or tea percolator, the combination with a receptacle open at the top and having a

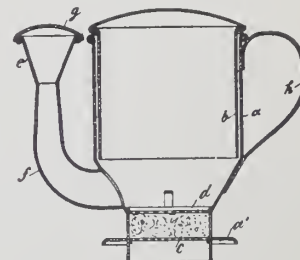

holder for the material to be treated at the bottom thereof, of a cover for closing the receptacle having a deep rim extending down into the receptacle with a clearance space between said rim and wall

of the receptacle, said cover being free to rise and fall with the variations in internal pressure and a filling branch for the infusing liquid opening into the percolator below the lower edge of the cover, the liquid forming a seal between the rim of the cover and wall of the percolator.

DESIGNS.

39,048. LOCKETT OR SIMILAR ARTICLE. FRANK W. ARNOLD, Providence, R. I., as-



signor to the Wightman & Hough Co. Filed Dec. 21, 1907. Serial No. 407,607. Term of patent 3½ years.

39,049. BEAD RING. ISAAC F. SCULLIN,

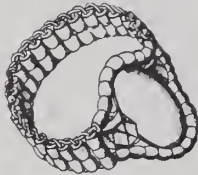

Waseca, Minn. Filed Nov. 6, 1907. Serial No. 401,031. Term of patent 7 years.

39,050. HANDLE FOR SPOONS, FORKS OR SIMILAR ARTICLES. GEORGE P. ITTIG, Bridgeport, Conn., assignor to the E. H. H. Smith Silver Co., Bridgeport, Conn. Filed



Dec. 19, 1907. Serial No. 407,267. Term of patent 3½ years.

39,051. GLASS DISH OR SIMILAR ARTICLE. WALTER E. EGGINTON, Corning, N. Y. Filed

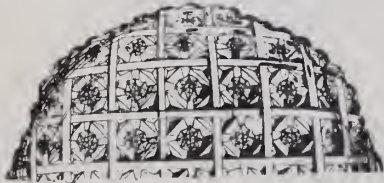

Nov. 14, 1907. Serial No. 402,212. Term of patent 7 years.

39,052. METAL DISH. WILLIAM KILIAN, Cin-



cinnati, O. Filed July 29, 1907. Serial No. 386,172. Term of patent 7 years.

UNITED STATES TRADE-MARKS.

[The following trade-marks have been adjudged entitled to registration under the Act of Feb. 20, 1905, and are published in compliance with Section 6 of said act. Said section provides:

"Any person who believes he would be damaged by the registration of a mark may oppose the same by filing notice of opposition, stating the grounds therefor, in the Patent Office, within 30 days after the publication of the mark sought to be registered, which said notice of opposition shall be verified by the person filing the same before one of the officers mentioned in Section 2 of this act. If no notice of opposition is filed within said time the

commissioner shall issue a certificate of registration therefor, as hereinafter provided for."

Marks which are stated to have been "Used 10 years" are registrable under the last proviso of Section 5 of said act, which is as follows:

"And provided further, that nothing therein shall prevent the registration of any mark used by the applicant or his predecessor, or by those from whom title to the mark is derived, in commerce with foreign nations or among the several States, or with Indian tribes, which was in actual and exclusive use as a trade-mark of the applicant or his predecessor from whom he derived title for 10 years next preceding the passage of this act."

PUBLISHED FEB. 4, 1908

Ser. No. **27,304.** (CLASS 27. HOROLOGICAL INSTRUMENTS.) NEWMAN CLOCK Co., Chicago. Filed May 11, 1907. Used 10 years.

Newman

Particular description of goods.—Time-recording clocks and dials therefor.

Ser. No. **31,862.** (CLASS 27. HOROLOGICAL INSTRUMENTS.) AMERICAN-SWISS WATCH Co., New York. Filed Dec. 20, 1907.

A.S.W.CO.

Particular description of goods.—Watches, watch cases and watch movements.

TRADE MARKS REGISTERED FEB. 4, 1908.

67,519. JEWELRY. S. & B. LEDERER Co., Providence, R. I.

Filed Aug. 1, 1907. Serial No. 29,164. Published Dec. 3, 1907.

67,531. LOCKETS, CUFF-PINS AND FOBS. ROBERT B. MACDONALD, Attleboro, Mass.

Filed Sept. 23, 1907. Serial No. 30,166. Published Dec. 3, 1907.

BRITISH PATENTS.

(ABRIGMENTS OF SPECIFICATIONS, 1906, FROM *The Illustrated Official Journal.*)

ISSUE OF JAN. 22, 1907

21,257. TIME-RECORDING LOCKS. J. F. PINLEY, Columbus, O., and LE G. C. BUSH, Chicago, U. S. Sept. 25. Period for granting patent not yet expired.

In a time-recording lock, the controlling-clock 180 makes connection every minute between a

the pointer 48, and the day-wheel may also be provided with a pointer 53. The recording-wheels are each provided with the necessary figures, so that when the printing-platen 107, Fig. 1, is pressed against them, a record of the exact time and date is printed on a paper strip 99. The bolt 25 is operable from outside by means of a cam 30, a projection 29 on which engages a recess 31, Fig. 11, in the bolt. The cam is turned by a key, the projection 29 raising the lever 32 to disengage its end 33 from the notches 34 in the bolt. As the bolt is operated, the wedge-shaped projection 35 thereon engages a similar projection 112 on a lever 111 pivoted to the case, raises the lever, and by means of a rod 105 pivoted thereto actuates the spools 93, 100, carrying the inking-ribbon 92 and paper strip 99, respectively. At the same time, the ratchet-wheel 106 on the spool 100 trips the lever 109 and causes the printing-platen to press the paper and inking-ribbon sharply against the recording-wheels. Also mounted on the recording-wheel shaft is a segment 82, Figs. 7 and 14, carrying type 83, which lies flush with that on the recording-wheels and is designed for the purpose of distinguishing the key which operates the lock. The different keys are so arranged that, when inserted into the keyhole, they push out the barrel 122, Fig. 12, slidingly mounted in the cam-piece 30, to various distances depending on the key, so as to bring a particular step 123 on the barrel into position to operate the lever 117, the free end of which engages a pin 83 on the segment 82, as shown in Fig. 7. The segment is thus turned to bring the distinguishing mark of the key used into position to be marked on the paper strip at the time of the operation. From the inside, the bolt is operated by a key inserted into the post 134, which is journaled in the casing and carries an arm 128. When the arm 128 is rotated, the inclined post 132 thereof first raises the locking-lever 32, and then the arm engages with one of the two stops 129, 130 on the bolt to operate the bolt. The time-recording apparatus is set in motion by the movement of the bolt, but the key-indicating segment 82 is not moved, the normal position thereof having the characteristic type of this key in the operative position. The various parts are returned to their initial positions by means of springs. The printing-mechanism may be thrown out of operation by means of a crank-arm 138, Fig. 7, operated by a key from the front of the casing, the arm acting on the bent end 147 of a rod 105 and raising it and the lever 111 until the latter is clear of the projection 35 on the bolt. A record is made of the time of operation. The key can only be removed from the lock when the crank-arm 138 is in the downward position. In this position, the arm 138 is retained by a sliding plate 140, a notch 143 in which engages a pin 139 on the arm. One side of the notch 143 is higher than the other, so that it is necessary for the arm 138 to make a complete revolution before the pin 139 can re-engage the notch. One of the spools for holding the inking-ribbon and paper strip is shown in Fig. 18. The spool 88 is secured on a shaft 87 by a screw 91 and spring 89. The spool is provided with slots 95 into which the end of the ribbon is placed, being secured by ribs 94 of the cap 93.

ISSUE OF JAN. 22, 1906.

22,010. CLOCKS AND WATCHES. II. CONTROL. LERY, La Chaux-de-Fonds, Switzerland. Oct. 5.

Balances and Balance Springs; Regulators (Mechanism of Governing Rate).—To allow adjustment of the period of oscillation between very

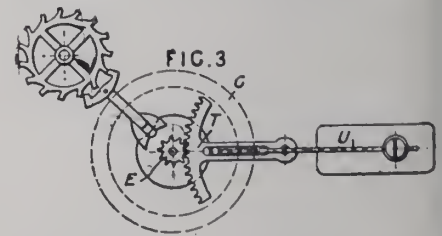
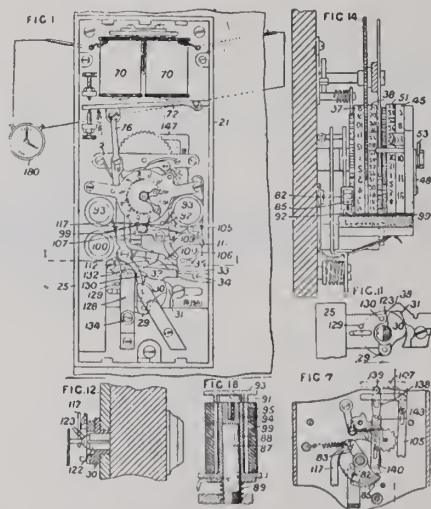

source of electric supply and magnets 70 mounted in the lock casing 21. The magnets attract their armature 72 which, on its return movement, by means of the rod 76 actuates the minut-wheel 38, Fig. 14, of the recording-apparatus; at every hour the hour-wheel 37 is rotated one step, and on completing the rotation shifts the day-wheel 51. The month-wheel 45 is rotated by hand by means of

wide limits, the ordinary hairspring concentric with the balance C is replaced by a straight strip U, which acts on the balance through the medium of a toothed sector T and a pinion E. When applied to a cylinder escapement, the cylinder is on the arbor of the sector. For regulation, the bar carrying the spring, or a bar carrying curb pins, is shifted by a rack and pinion.

News Gleanings.

Chas. D. Hunt, Garnet, Kans., has sold a half interest in the store to Walter Warren.

The business of C. H. Ward, Brandon, Vt., has been closed out under a chattel mortgage.

A voluntary petition in bankruptcy has been filed by Herman Fredell, North Yakima, Wash.

It has been reported that a petition in bankruptcy has been filed against J. G. Erwin, Harriman, Tenn.

Clarence Cheever, formerly of Exeter, N. H., has removed to East Rochester, N. H., and opened a new store there.

E. R. Spear & Co., Rockland, Me., are offering to settle with their creditors on a basis of 40 per cent. on the dollar.

C. D. Hawley, Lillington, N. C., has removed his jewelry business from that town to Franklinton, in the same State.

Will H. Beck, of the Will H. Beck Co., Sioux City, Ia., has recently been elected president of the Sioux City Commercial Club, of that city.

The Baird-North Co., of Salem, Mass., is closing out its stock there, and will consolidate its entire business at Providence, R. I.

A recent fire at Berlin, N. H., which destroyed property valued in all at about \$100,000, entirely destroyed the stock of G. T. Bradbury, a retail jeweler of that place.

A severe storm, Jan. 25, broke both the show windows in the store of M. R. Myers, Colorado Springs, Colo. Vigilant attention on the part of the local police prevented any loss by theft.

A recent dispatch from Oaxaca, Mex., announces that the Government pawnshop was entered by thieves and robbed of diamonds worth \$40,000. Several suspects have been arrested.

Hardway & Williams is the name of a new concern at 709 Garrison Ave., Fort Smith, Ark., G. W. Hardway having recently taken as partner C. E. Williams, formerly of Springfield, Mo.

J. D. Huggins, owner of the Southside Jewelry Store, Youngstown, O., started recently on a trip to California and the Pacific Coast. He expects to return to Youngstown early in the Spring.

Reed & Barton, Taunton, Mass., last week presented a massive silver punch bowl, one of the handsomest of its kind ever produced at the works, to St. Mary's Catholic parish in Taunton.

A. Andrews, San Francisco, Cal., recently completed an order for a lady's riding crop having a 10 carat white diamond in the end of the gold handle. The handle itself is pierced open work and is studded with several small emeralds and diamonds.

H. W. Dexter, Lyndonville, Vt., it is stated, is financially embarrassed. The sheriff holds stock under a chattel mortgage for \$1,000 and also under attachment of the Globe Optical Co. The assets compounded by the sheriff amount to over \$2,500. Dexter started at Springfield, Vt., in 1903, and moved to Lyndonville about a year ago.

Webb C. Ball, Cleveland, O., has been named as general inspector of the Delaware and Hudson railroad, New York, and

with his appointment the office of chief watch inspector is abolished. Mr. Ball, whose office is in Cleveland, is inspector of most of the large railroads in the country.

Max Marcus & Co., 92 State St., Chicago, are in financial difficulties. According to a statement made to the creditors the debts amount to about \$16,275 and the assets about \$11,200. If from the latter bad accounts are deducted they will amount to about \$12,400. It is, therefore, proposed to offer a settlement to creditors on a basis of 40 per cent. The concern attributes the troubles to bad business during the past year.

A thief entered the jewelry department of the store of Irving A. Willey, 86 Main St., Brockton, Mass., recently, and walked out with a large and expensive porcelain clock. The clerk in charge had had his attention distracted for a few moments, and was standing only a few feet away. The stranger was not seen to enter or leave, but it was learned afterward he was seen walking leisurely away with the clock under his arm.

Charles Whiting, head of the firm of Whiting & Davis, North Attleboro, Mass., and Mrs. Whiting, were passengers in a train that was run down by a delayed flyer in the Buffalo, N. Y., station last Tuesday. When the crash occurred, the train in which Mr. and Mrs. Whiting were passengers, was pulling into the station. Mrs. Whiting was thrown heavily against a seat and sustained a fractured arm and minor injuries. Mr. Whiting escaped without injuries. At the time of the accident, Mr. Whiting was returning from a business trip. He arrived in Plainville Monday.

The American Trust and Savings Bank, Chicago, receiver for the National Jewelry Co., is soliciting bids for the assets of the bankrupt, now located in the premises which the concern formerly occupied in the Mentor building, 162 State St., Chicago. Bids will be received until 9 A. M. Tuesday, Feb. 18. The stock consists of gold jewelry, plated silver, cut glass, decorated china, watches, clocks, etc., and these and the fixtures, furniture, machinery and other assets will also be sold at the same time. In the event of no satisfactory bids being received the assets will probably be sold at auction without further notice. Each bid must be accompanied by a certified check of not less than 25 per cent. of the sum offered.

A. L. Thoma, Piqua, O., recently acted as temporary chairman of the meeting at which the Piqua Business Men's Association of that town was organized, and later was elected unanimously the president of the organization. Mr. Thoma is an optician and member of the firm of A. Thoma & Sons, whose business was established in 1838. He is also the organizer of a new lodge for jewelers and opticians known as the Noble Order of Ku-Kus, Lodge No. 1, of which will be instituted in Piqua in March. The object of the new organization is to permit sociability among the members of the trade, eradicate trade jealousies, etc., and to provide the fun and frolic at all State and national conventions.

Work on the beautiful silver service which will be presented to the battleship *New Hampshire* by the citizens of the State after which it is named is now going on,

the design having been approved last week by New Hampshire's Governor and Council and a special committee. The service, which will cost \$6,000, is one of the most beautiful that has been made for a battleship, and will consist of a punch bowl and ladle, with 24 punch cups which are combined with a plateau containing candelabra, all forming a magnificent centerpiece; four large compotes, 12 finger bowls and plates, six bonbon dishes, six candlesticks, a small centerpiece and vase, salad bowl and loving cup. The service will be furnished by the John B. Varick Co., Manchester, N. H. It will be made by the Wm. B. Durgin Co., Concord, N. H.

By means of footprints in the snow three men believed to be burglars and guilty of robbing the Smith jewelry store on State St., Watertown, N. Y., were traced by the police one day recently and arrested. The jewelry store was robbed shortly after midnight, Jan. 25. A pedestrian who passed by the store of Smith saw the men at work and immediately went for police officers, who came back with him to the store, but by that time the men had gone. From the rear of the store, however, the footprints of the robbers were plainly visible in the snow which had just fallen, and the police traced the prints to a small shanty, where Edward Woodcock, Harry Sheetz and Clarence Kirby were arrested. In their clothes a quantity of jewelry was found. After being locked up in the police headquarters at Watertown the men made an attempt to escape, which was frustrated just as they had sawed through one of the bars of a cell.

Baltimore.

The firm name of Walter Powell & Sons, 103 Baltimore St., this city, has been changed to the Walter Powell & Sons Co. All obligations will be assumed and paid by the new firm.

Mrs. Mary Swayne, aged 97 years, widow of Benjamin Swayne, who for several years conducted a jewelry store on N. Charles St., this city, died about a week ago at her home at the corner of Calloway and Park Aves., Forest Park. She is survived by one sister.

Wm. Brown, a negro, alias John Sawyer, who gave his address as 2030 Alice-Anna St., this city, was recently arrested after failing to give a satisfactory explanation as to how he obtained a large amount of jewelry and watches. When taken into custody he had in his possession 11 open-face watches, two hunting-case watches, 58 rings, three pairs of cuff buttons and three lockets. The police believe that the stock was stolen in Norfolk, Va.

Lima, O.

The Macdonald Jewelry Co., which was started by R. D. Macdonald, who later sold the business to open a new store under the name of R. D. Macdonald, is now conducted as the Hughes & Sons Jewelry Co.

E. M. Hale, of Hale & Co., who were in business here for 40 years, and who sold out last Spring, on Feb. 6 was married to Mrs. M. Sheppard. The groom is 72 years old and the bride 66 years. Both are widower and widow, respectively.



WALTHAM JEWEL SERIES WATCHES

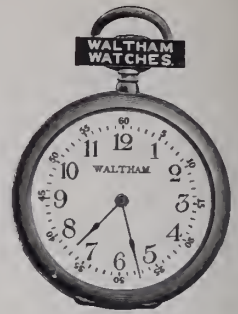

DIAMOND; NICKEL;

17 diamond and ruby jewels; both balance pivots running on diamonds; raised gold settings; steel escape wheel; exposed sapphire pallets; compensating balance, adjusted; meantime screws; patent Breguet hairspring, hardened and tempered in form; patent micrometric regulator; tempered steel safety barrel; gold train; exposed winding wheels.

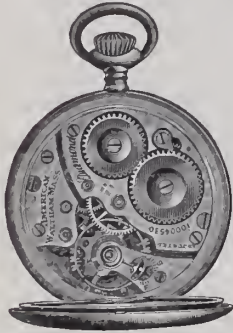

RIVERSIDE; NICKEL;

17 fine ruby jewels; raised gold settings; steel escape wheel; exposed sapphire pallets; compensating balance, adjusted; meantime screws; patent Breguet hairspring, hardened and tempered in form; tempered steel safety barrel; red gold center wheel; exposed winding wheels.

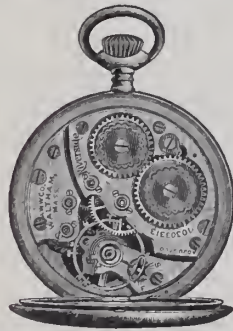

RUBY; NICKEL;

15 jewels; raised settings; exposed pallets; compensating balance; meantime screws; patent Breguet hairspring, hardened and tempered in form; tempered steel safety barrel; exposed winding wheels.

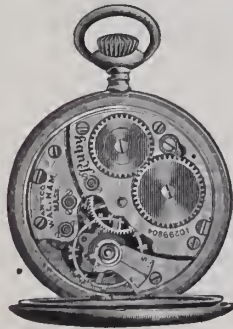

HUNTING OR OPEN FACE

These movements may be obtained in a great variety of Gold Cases, from Plain Polished to the most elaborately Engraved, Carved and Enameled.



Movements Manufactured and Guaranteed by
WALTHAM WATCH COMPANY
WALTHAM, MASS.



THE HOROLOGICAL REVIEW

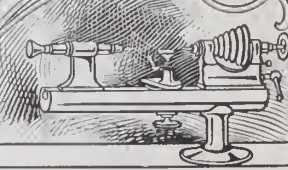

Watch Repairing.

By H. REINECKE.

(Continued from issue of Jan. 1. See also issue of Feb. 5.)

A GAUGE may be provided by means of which single degrees and parts thereof could be measured in angles as laid down in drawings and descriptions furnishing instruction for the practical construction and examination of a lever escapement. Our Swiss and English friends, a little older in the business than ourselves, are better supplied than we are so far in this respect. The Swiss for a number of years

ver. The body A, Fig. 1, is a circular plate, four inches in diameter and three-eighths thick, and is supported by three feet. The center of this plate forms the upper hole of a pivoted index B, which runs under the surface of the plate and comes through a circular notch about one inch from the center; this index is governed by a balance spring, the inner end of which is secured to the index staff, the outer end to a stud that is attached to a contrate tooth wheel which is made to revolve concentric with the staff hole by means of pinion C, Fig. 2, being geared into it.

"This pinion is attached to an inner end of an arbor, D, which revolves friction-tight on turning the nut, E, attached to the outer end, which causes the index to fly to one end of the notch in plate A, Fig. 1, and by turning the nut in the opposite direction the index will fly across to the other end, and by turning it a little back the index may be left to swing in the middle of the notch.

"On the top of index B is fitted a slide, C, which slides spring-tight to or from the center, and which has at the inner end a movable arm, H, that has an up and down action. The use of this slide and arm will be presently explained. Upon plate A, Fig. 1, are fixed two pillars, K K, upon which is carefully fitted a movable bridge, L, and which is secured by two screws, M M. In the center of this bridge is an upright center, F (similar to the center of an upright tool), which is concentric with index B. P P are two steel dogs which have parallel adjusting screws that are not shown in the engraving. R R are two nuts for the purpose of tightening the dogs.

"S S, Fig. 2, is a plate that revolves spring-tight concentric with the index B, and to which is secured by two pillars, T T, the scale plate, Y, which lays a little over plate A, Fig. 1. The reason of scale being made to revolve is to facilitate the reading; it is engraved to measure to the half degree, but can be easily read to the quarter degree, and with a little addition, by means of a scale attached to the index, it will measure to the minute, or even less, the following angles, viz.: The lifting angles of the pallets, the depth of the wheel and pallets, the amount of run the wheel has on pallets, the amount of unlocking, the amount of impulse at the balance, the amount of shake ruby pin has in lever notch, the amount of side shake of pallets, staff, pivots and the amount of banking shake.

"It may be mentioned that from the extreme delicacy of the scale, the slightest

want of truth in the escape wheel can be instantly detected. In accurately measuring an escapement it is necessary in the first place to measure the shake ruby pin has in lever notch, as also the side shake of pallets' staff pivots, as they form a most important part in the other measurements, and, as an example, we will take the shake of ruby pin in conjunction with shake of pallets' staff pivots to be a half degree.

"To measure a three-quarter plate escapement, the pillar plate is laid upon plate A, with the escapement toward the index. Center F is then pressed into pallets' staff hole, and the pillar plate secured by two dogs, H H; the bridge is then lifted off and

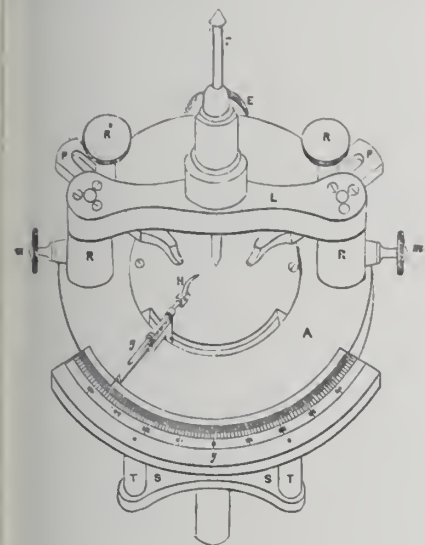

FIG. 1

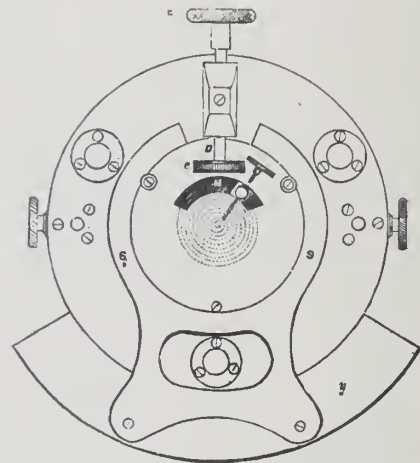

FIG. 2.

the escapement put in, and slide G drawn out, and the movable arm pressed down against one side of the lever; the screw, E, is then slightly turned, which will cause the slide, G, to be pressed against the side of the lever, and the lever to be forced against one of the bankings; consequently the lever and index become one, having one common center; it therefore follows that as the lever moves so does the index. Now with a gentle pressure upon the escape wheel and carefully watching the index, the balance is brought in contact with the lever and moved round until the wheel comes to the corner of the locking plane, which will cause the index to jump suddenly half a degree, on account of the wheel running down the lifting plane to that extent, and forcing the lever from one side of the ruby pin to the other; the index will then register (less half a degree) the unlocking; the balance being still further moved round until the wheel drops, the index will then register

have had an escapement depthing tool with three pairs of centers, by means of which any kind of a lever escapement, whether a straight line or angular one, could be planted in the watch movement plate or an escapement fully finished with balance in position could be examined by a watch repairer. One can hardly realize how much practical instruction such a tool affords.

The British Horological Institute, alive to the importance of such an escapement gauge, appointed a committee, empowering the same to offer a prize for the production of the best gauge of such a description. It is recorded that first prize for the best instrument of this sort was awarded to Mr. Bridgman.

Mr. Bridgman furnished a drawing and description of this device which was described in the *British Horological Journal*, as follows:

"The instrument is made of German sil-

How A Watch Business Was Tripled

The demand for the G. M. Wheeler grade Elgin, ever great, has been tripled by adding two sizes 12 and 16 thin models, thus making it a watch for the millions.

Perhaps you have also noticed that the

G. M. Wheeler Grade **ELGIN**

is being liberally advertised in all the great business-bringing publications. So you see it is just as plain as putting 2 and 2 together, that every progressive jeweler should carry this movement in all three sizes—18, 16, 12.

See jobbers' list for prices
or write the Company.

*Send for the Elgin art booklets,
"Timemakers and Timekeepers" and "The Watch."*

ELGIN NATIONAL WATCH COMPANY,

Factories, Elgin, Ill., U. S. A.
General Offices: 131 Wabash Ave., Chicago.
New York Office: 11 John St.



(plus half a degree) the lifting angle of that pallet; the balance is then turned back until the wheel comes to the edge of the locking plane (which will again cause the index to jump half a degree from the same cause as before). The index will then register (less half a degree) the depth of the wheel on that pallet; the balance being still further turned until the wheel drops, the index will register (plus half a degree) the lifting angle of the other pallet. The balance being still further moved, until the lever touches the banking, the index will register the run of the wheel on the locking plane.

"To measure the shake of ruby pin is simply to turn the balance round until the pin comes into the notch, then fixing the balance by a piece of cork and pressing the lever by the opposite side to that in connection with the arm, the index will register (less the side shake of pallets' staff pivots) its measurement. The banking

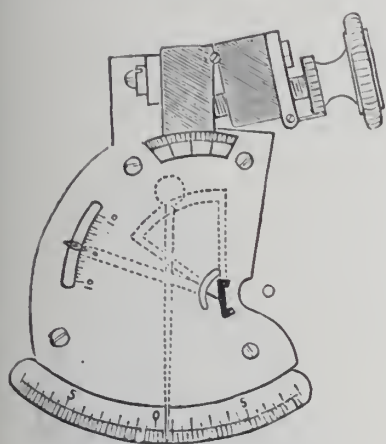

CURZON'S DEPTHING TOOL.

shake is measured in the same manner, with the ruby pin of course away from the lever notch. To measure the side shake of pallets' staff pivots the balance is taken out, and consequently the lever would be forced against one of the bankings, and the pivots to one side of the holes, then by simply pressing the lever so as to force the pivots to the opposite side, the index will register the side shake of the pivots.

"To measure the impulse at the balance the bridge is again put on, and center, F, pressed into the balance staff hole, the pillar plate is then secured as before, and the bridge being removed, the slide, G, is drawn out and the arm pressed down to the side of one of the screws of the balance; or if a plain balance, to the side of one of the bars; consequently the balance and index become one, having one common center, it therefore follows that as the balance moves so does the index. The balance is then moved round until the wheel comes to the edge of the locking plane, and being still further moved from this point to the drop of the wheel, the index will register the impulse at the balance arising from the wheel passing over the pallet plane.

"In measuring a full plate escapement, the movable arm at the end of lever G is removed, and one of a different shape substituted, so as to enable it to pass between the plates to the lever. It is not necessary to suggest the shape of the arm, as that may

be left to the judgment of the person using the instrument.

"It will be seen by the brief description here given that to arrive at the various measurements is simply to try the escapement in the ordinary way, the only difference being that the escapement is attached to the instrument, which registers the measurements in degrees."

At a later season a more simple tool was constructed by Mr. Curzon, which is considered quite sufficient for all practical purposes. This tool is also fully described in the publication mentioned above. It is also described and illustrated in Saunier's "Watchmakers' Handbook," on pages 418 and 419. The accompanying illustration shows an ordinary depthing tool, to which a scale is attached. A hand adapted to the pallet staff supported between one pair of runners of the depthing tool gives motion to a curved rack (shown by the dotted lines), and this causes a pinion, carrying a second index to rotate the radii being so related that the movement of the staff is magnified four times on a scale which can be observed while the glass is at the eye examining the pallets. The index which travels over the shorter scale to the left (divided up to 10 degrees on either side of zero), is connected with the pallet staff by a fork and a short arm passing through the circular groove; it affords a convenient means of moving the pallets while testing them and gives the degrees of their motion. The graduated arc shown at the top is for measuring the lever and roller.

(To be continued.)

Shakespeare and Clock Makers.

"DID you ever notice that most people who are fond of Shakespeare have more or less mechanical ingenuity?" the owner of a big manufacturing plant asked the other day. "I don't attempt to explain it, but I think the rule will hold good. Perhaps the exactness of thought which the constant study of his works will surely produce has something to do with it; for, after all, mechanical ingenuity is nothing more nor less than clear thinking. Shakespeare himself was very careful in his references to mechanical details, and I have been told by a sea captain that the commands given in 'The Tempest' are just the ones which would have been given on board a ship under the circumstances described.

"What I started out to tell you about, however, is a clock which has been constructed by one of my mechanical experts, who is extremely fond of Shakespeare. He is rather retiring in his disposition, and it was from some of the other men that I first heard of it. When I asked him about it, he seemed much pleased, and invited me to visit his home and see the device. When closing time came, I took him in my machine, and we went to his house together.

"When he pointed out the clock, at first I noticed nothing remarkable about it, except that its base was rather large in proportion to the size of the face. Upon observing more closely, however, I saw that it was painted so as to represent the lowered curtain of a theater. It lacked about two minutes to six o'clock, and the man asked me to sit down.

"As the minute hand of the clock touched 12 the little curtain—which was of cloth, and not painted on the clock, as I had supposed, rolled up, disclosing a little stage, with two little figures on it. They were about three inches tall, and perfectly modeled and costumed. They appeared to be holding a conversation, and a small voice said distinctly:

"How's the day?"

"On the sixth hour, at which time, my lord, you said our work should cease," was the reply, and then the little curtain dropped.

"Act V., 'The Tempest,'" the man said, seeing probably that, as I am assumed to confess, I did not recognize the quotation.

"This is very interesting," I said. "It is a pity that there are not enough quotations to give one for every hour; in the event that it would be possible to fix your clock to give the proper one at the proper time. Of course I see that you have utilized a phonograph to give the dialogue."

"He smiled in a way that made me feel like an assistant in a packing house. 'Oh, there are enough quotations—one for every hour—and it was not extremely difficult to arrange the mechanism—merely a time release on the spring of the phonograph,' he said. 'I will start it at one and let you hear them all, if you care to.'

"I should be very glad indeed," I told him.

"He stopped the clock, turned it back to one and sat down. The little curtain rolled up, and the miniature performance began. The two actors did not change costume; but they had been rather ingeniously arrayed, so that their clothing did not seem inappropriate except when the quotation was from 'Julius Cæsar.' The man said that he hoped to have a complete change of characters in course of time, but that would require rather elaborate mechanism, and a somewhat large box. After each scene he would turn the clock forward an hour, and I heard the following quotations, which I jotted down:

"The bell then beating one.' (Hamlet, Act I.)

"Sure, Luciana, it is two o'clock.' (Comedy of Errors, Act II.)

"The clock hath stricken three.' (Julius Cæsar, Act II.)

"How far into the morning is it, lords?—Upon the stroke of four.' (Richard III., Act V.)

"At five o'clock I shall receive the money for the same.' (Comedy of Errors, Act IV.)

"How's the day?—On the sixth hour, on which time, my lord, you said our work should cease.' (The Tempest, Act V.)

"Let's see, I think 'tis now some seven o'clock.' (The Taming of the Shrew, Act IV.)

"The eighth hour—be that the uttermost?' (Julius Cæsar, Act II.)

"It's supper time, my lord—it's nine o'clock.' (Richard III., Act V.)

"Ten o'clock; within these three hours 'twill be time enough to go home.' (All's Well That Ends Well, Act IV.)

"Eleven o'clock the hour.' (Merry Wives of Windsor, Act IV.)

"What hour now?—I think it lacks of twelve.' (Hamlet, Act I.)

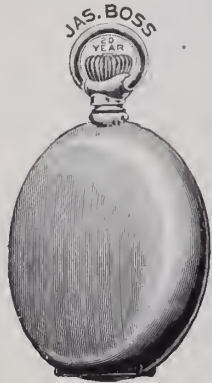

B.015.

Betsy Ross Watches

- ¶ Are not a new or untried proposition.
- ¶ They have been on the market for three years.
- ¶ They have proved their worth.
- ¶ The MOVEMENTS are conceded by the trade to be the best O size, seven jewel movements made in the United States.



B.0115



B.2043

- ¶ The CASES (Jas. Boss guaranteed for twenty years) need no introduction.
- ¶ They satisfy the trade in selling and profit making qualities.
- ¶ They satisfy the public in time keeping qualities and artistic merit.



B-2014

Sold by all leading jobbers

MADE AND GUARANTEED BY

The
Keystone Watch Case
Co.

New York
Chicago

Philadelphia
Boston

Cincinnati
San Francisco



B.2038



B.2025

"Well, I thought to myself, after I had left the man's house, 'he has at least overlooked the fact that he might have his clock all the months; for it's a cinch that if there is a quotation for every hour of the day, there will be one for every month in the year'; so when I got home I started to make out a list; but much to my disappointment I found only three—for March, April and May. They occur in Julius Caesar, 'The Tempest,' and 'Henry V.'—*New York Tribune*.

Sun Dials and the Unification of Time.

FOR a number of years there has been in existence a portable solar chronometer that effects, in the most simple manner, the solution of the problem which M. Aurelle Montmorin has sought to solve.

If I am not mistaken, says L. Reverchon in the *Revue Internationale*, this apparatus is the invention of Molteni. The accompanying sketch indicates its general construction. To a cast metal base is attached a spherical cap, bearing the hours inscribed on its circumference. A joint permits of its adjustment in a vertical direction.

Around the circle of hours a metallic piece, made in two parts, can be moved, one oval, convex in the segment of a sphere *H*, and engraved with the curve in eight of the equations of time, the other serving to support a lens *F*, movable about its horizontal axis, and of which the focus is found at a point on the surface of the segment of a sphere showing the course of the equation of time.

The latter is divided at two points corresponding to the different periods of the year. This can be adjusted as follows to be part of the world in which it is desired to use the Molteni solar chronometer:

The pedestal is placed on a perfectly horizontal base, so that the axis around which the point of the cap of the hours moves is perfectly perpendicular to the direction of the meridian of the locality. The pedestal is then firmly fastened and it will then, for an indefinite period, serve to indicate the time.

To tell the time at any minute of the day, it suffices to dispose the movable part until the luminous point formed at its focus by the lens is brought exactly on to the bearing of the curve in eight. The time is read on the circumference of the circle of the hours by means of an index *A*, the accuracy of which is increased by the addition of a vernier.

When the curve is divided carefully, the points arranged with regularity, and the lens so disposed as to furnish a clear point of light, we can tell the time by means of this instrument within two minutes as a maximum deviation.

It is certain that if the form was magnified even greater precision would be assured; but the cost would, of course, be much higher. As it is, it suffices perfectly for the purpose for which it is intended, and its price is very reasonable (about 100 francs).

I would add that if at the same time with this timekeeper, the operation of which would be interesting to spectators in enabling them to comprehend some ideas in practical astronomy, the operator possessed

a good watch, of which he closely understood the daily rate, he would have at his command all that is really necessary for the train of a tower or town clock.

In the meantime—until doomsday—electric unification with wire connection or wireless. It is to the desire to have a clock as correct as possible that we owe the numerous sun dials that remain to us from past centuries, and the many works in which the authors, in some cases men of distinction, have undertaken to give accurate directions for the construction of these timekeepers.

Gnomonics has been made the subject of numerous treatises, of manuals and dissertations in all languages. Pierre Dubois has quoted about 80 treatises on works relating to this subject. Among the large number there are some that are of definite value, and of which we may say what Montucla wrote of the *Traité de l'Horlogiographie du Père de Ste. Madelaine*: "It is a unique

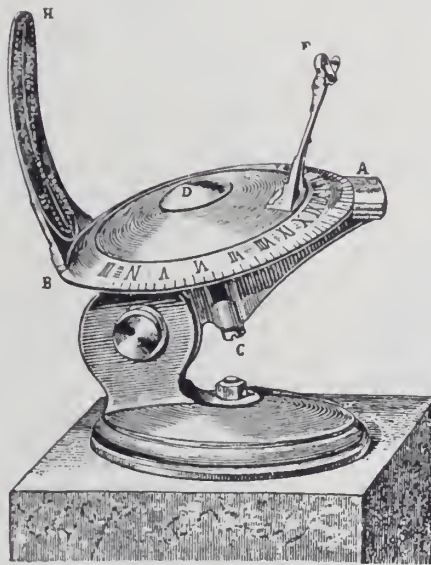

PORTABLE SOLAR CHRONOMETER.

work for this class of masons who travel through the country and make their living laying out sun dials."

There are also some that are absolutely unreadable, like that of Père Clairus, as indigestible as voluminous, or that of Père Voël, a work that is preceded by a dedication that is quite ridiculous.

There are some, on the other hand, that are of real value, such as *Gnomonique de la Hire*, published in 1683; that of *Ozanam*, published a few years later, and—which is more clear—*La Gnomonique de Rivard*, published in 1767.

The *Gnomonique du Duparcieux*, published in Paris in 1741, has met with equally marked appreciation, and deserved it, as well as did that of Wolf. Nevertheless, the most important of these works is that of *Dom Rédos de Celles*, which first appeared in 1770 and had several later editions, entitled "*Gnomonique pratique, ou l'Art de tracer des cadrans solaires avec beaucoup de précision*," it fully merited its title, and even to-day it may be consulted advantageously.

It may be objected that the employment of a solar chronometer involves the determination, with accuracy, of the local meri-

dian. This is an objection having but little weight.

We can determine, on the ground itself, the direction of the meridian, by means of three simple observations of the shadow of a rod at three different times. This method of determination, by means of three unequal shadows, is to be ascribed to an old Italian author. Old works on the sun dial furnish full practical directions.

But it is not even necessary nowadays to have recourse to such an undertaking. That was good enough for times when the watches went as they pleased and when they were set by means of a small sun dial, the style or gnomon of which was concealed under the cover and which furnished indications more or less problematical.

Nowadays a watch keeping time exactly within a few seconds per day is no longer a curiosity, and with such a timepiece it is easy to dispose a solar chronometer in the direction of the meridian, a water level being employed to insure a perfectly horizontal pedestal.

It suffices to place it in such a manner as to cause it to record noon, as already indicated at the time indicated by the watch. The base is then fastened and the chronometer discharges its functions indefinitely, without the least attention. It is easy to appreciate the value of an instrument with the aid of which the time can be made uniform.

I have said that a solar chronometer is worth a certain sum.

They are not sold in large numbers. But the number of communities that would be interested in their use is considerable. In France, for instance, there are fully 15,000 communities in which an installation of this description would be of value. And it is just as certain that with 15,000 solar chronometers to install, the cost could be reduced one-half. It certainly would not be an expense of a million for the 15,000 communities or localities which are interested.

This is the unification of time for nothing, or at least at a great reduction of outlay.

And in addition to this advantage, the installer could use the apparatus placed at his disposal for giving one or two lessons in cosmography and practical astronomy to his pupils.

It frequently happens that even in very poor localities 50 francs are expended for a less worthy object.

The firm of R. J. F. Roehm & Co., Detroit, Mich., which has been located for 10 years at 184-186 Woodward Ave., has closed a lease for new quarters in the Business University building, Wilcox and Farmer Sts. In the future the firm will cater, in its retail department, to a fine class of trade, handling the best makes of goods. The manufacturing department, devoted mainly to college and fraternity jewelry work, will have space on the second floor of the same building. The factory has a fine equipment of new and up-to-date machinery, fitted with individual motors. Mr. Roehm, founder of the house, is a veteran in the jewelry business and was the pioneer in the insignia line.

Ball Watches

THE RAILROAD STANDARD

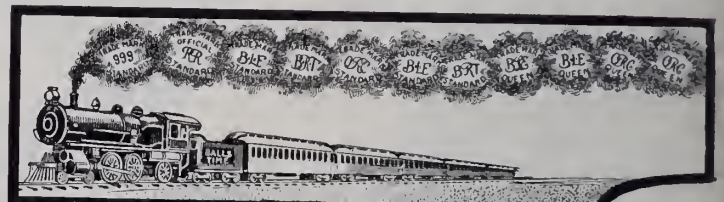

☞ Reputable dealers will find Ball's Railroad Standard Watches a most attractive business proposition to handle. People are beginning to demand in their watches, the same perfect accuracy that railroad men require, and nothing short of a "Railroad Standard" will prove satisfactory.

☞ The Ball Watch is built for railroad service—strong, durable and accurate. It is adjusted to all conditions of temperature, and to five positions, and made in both 16 and 18 sizes.

☞ We sell reliable dealers only—no mail order houses or department stores. Every Ball "Railroad Standard" Watch goes out cased up complete, in crack timekeeping condition, all ready for your customer's pocket. Sold at an established uniform price that never varies; each one placed means another satisfied customer for you, and fair return on your capital and time invested.

You are interested—write to-day for dealer's proposition.

THE WEBB C. BALL WATCH CO.

BALL BUILDING
CLEVELAND

RAILWAY EXCHANGE
CHICAGO

REMOVAL

FROM

PHILADELPHIA to NEW YORK

No. 35 MAIDEN LANE

Wm. C. Penfold Co.

Largest Exclusive Watch Jobbers in New York

OF

Dueber-Hampden Watches Dueber Cases—Hampden Movements

A COMPLETE LINE ALWAYS ON HAND

Mail Us Your Orders

New England

“The Watch for the Great American People”

THE vast majority of American watch buyers want simply this: *the best watch possible at the lowest price possible.* You, as a progressive dealer, with your finger daily upon the public pulse, must realize the power of public sentiment—your competitor does if you do not. And the *only* watch made to meet these conditions is the accurate, durable, economical *New England.* It pleases the *people* best and will pay *you* best.

The New England Watch Co.

Waterbury, Conn.

CHICAGO

SAN FRANCISCO



The above TRADE MARK is well known to you, because it is on every watch and watch movement made by the LANGENDORF WATCH CO.

The more of our large line you carry in stock, the more profitable and satisfactory are

YOUR SALES

Perfect Interchangeability of parts renders repairing easy.

Do not accept substitutes, but insist upon getting the genuine L. W. Co. make. It's far the cheapest after all, as the quality is such you may

DEPEND UPON

If your jobber cannot supply you with

THE RIGHT KIND of GOODS

write to the Sole Agents for the United States,

AMERICAN-SWISS WATCH CO.

1 Maiden Lane, New York
CUSHMAN BUILDING

49 out of 85 Prizes

WERE AWARDED TO

Patek, Philippe & Co. Watches

IN THE TIMING CONTEST OF THE ASTRONOMICAL
OBSERVATORY IN GENEVA FOR THE YEAR 1906
20 MANUFACTURERS COMPETING

1905—46 out of 65 Prizes, including First and Highest Prizes.

1904—36 out of 46 Prizes, including First and Highest Prizes.

1903—42 out of 54 Prizes, including First and Highest Prizes.

Hors Concours (Beyond Competition) Milan Exposition, 1906.

St. Louis, 1904; Paris, 1900; Chicago, 1893.

THEIR RECORDS FOR TIME KEEPING PRECISION
HAVE NEVER BEEN EQUALED

68 Nassau Street,
New York

Geneva,
Switzerland

"Full of Years and Honors"



* V. & C. *

Vacheron & Constantin Watches

have been recognized as standard for 122 years, during which time they have made records for efficiency, captured prizes against all competitors for accuracy and reliability, and gained a reputation among the trade and the general public which is not equaled by that of any other watch in the world. Their remarkable salability is due to these facts.

The public recognition of superior quality is the best advertisement which any article can have, and the high reputation of Vacheron & Constantin Watches is a continuous source of profit to every dealer who sells them.

The line embraces every variety of adjusted watches, complicated watches, extra flat, ultra flat and enameled, carved and jeweled watches.

Edmond E. Robert

SOLE AGENT

3 Maiden Lane, New York

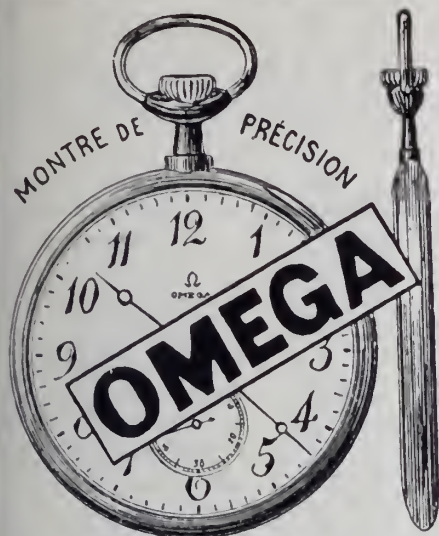

Easiest to Sell and Surest to Satisfy

¶ The experience of the public with Omega movements has been most gratifying. These movements have been very widely introduced and extensively sold, and their remarkable accuracy and reliability are well known to the general public.

¶ Whoever carries a watch with an Omega movement becomes an enthusiastic advertiser for the movement itself, and the store where he bought it. It is absolutely dependable and a movement which the most conscientious dealer may recommend to his customer with the utmost certainty that thorough satisfaction will be the result.

They sell well — they stay sold — they bring new customers.

¶ Omega movements are made to fit American cases and a number of Swiss sizes. Every part is interchangeable, and all are made with lever escapements, double roller, and pendant set. There are six different grades — from seven jewels to twenty-one jewels — adjusted to heat, cold, and five positions.

Send for our Price List. Prices are not advertised.

EDMOND E. ROBERT
3 Maiden Lane New York

WESTERN SELLING AGENCY
Omega Watches
Heyworth Building, Chicago

CROSS & BEGUELIN
31 Maiden Lane New York

GUINAND'S RELIABLE SPLIT TIMERSAND.... SPLIT CHRONOGRAPH WATCHES

In NICKEL, GUN METAL, SILVER
AND GOLD FILLED CASES

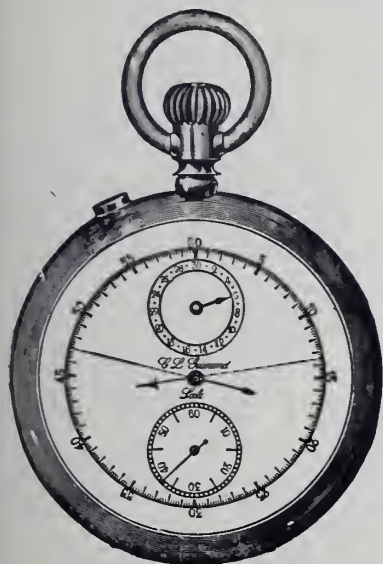

JULES RACINE & CO.

EXCLUSIVE IMPORTERS

Chicago Office: 103 State Street
New York Office: 37 Maiden Lane

FOR SALE BY ALL JOBBERS



C 505—Carved

CASES FOR PRESENTATION

Special designs furnished
for all occasions :: :: ::

American Watch Case Co.

9-11-13 Maiden Lane

New York

A.W.C.CO

Cases stamped with this mark appeal to the dealer who wants the best. ¶ Our salesmen are now out. If they do not call on you, order direct from us.

14 K. and 18 K. Gold Cases

A.W.C.CO



C 336—Diamond

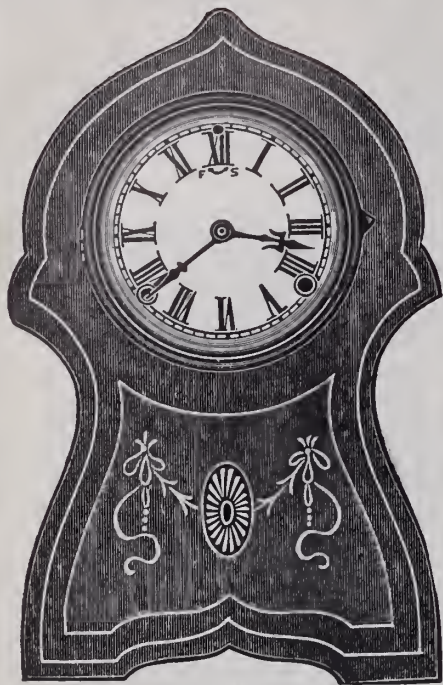

MANCHESTER
Height 133/4 in. Width 83/4 in.

SESSIONS CLOCKS

Superior Finish
Popular Prices

We have added a number of fine marqueterie cabinet clocks to our line which will interest you.

The Sessions Clock Company

FORESTVILLE, CONN., U. S. A.

New York Salesroom, 37 Maiden Lane

HALL CLOCKS



Elliott's
Celebrated
Tubular
Chimes

**HARRIS &
HARRINGTON,**

12 BARCLAY ST.,
NEW YORK

Sole Agents to the Trade
for
J. J. ELLIOTT & CO.
LONDON.

MAKERS OF
Tower and Street Clocks
For particulars write us, mentioning The Jewelers' Circular Weekly.
E. HOWARD CLOCK CO.,
EST 1842. BOSTON, MASS., U. S. A.

4
(Pat. applied for.)
Balance Hole Jewels. Size of the hole numbered on setting. Saves time and duplication. You can order just what you want. If your jobber does not handle them, send to us. Made for all kinds of American movements.
Ruby and Sapphire, \$1.25 per dozen
THOS. J. JUZEK & CO., Elgin, Ill.

THE R. OIL
NEVER GOES WRONG
The trade from ocean to ocean is praising this wonderful oil. IT POSITIVELY WILL NOT GUM.
Can you say as much for the oil you are using? Send 25c. to your jobber for a bottle, and end your oil troubles.
RANLETT & LOWELL CO.
SOLE MANUFACTURERS
Jewelers' Building BOSTON, MASS.
Wholesale Selling Agents
M. SICKLES & SONS Philadelphia
SWARTCHILD & CO. Chicago
NORDMAN BROTHERS CO., San Francisco
D. C. PERCIVAL & CO. Boston
CHAS. MAY & SON Boston
DANIEL PRATT'S SON 53 Franklin Street, Boston
SUSSFELD, LORSCH & CO., New York City
H. S. MEISKEY CO. Lancaster, Pa.

IF IT'S A

TRADE MARK REGISTERED
IT'S STANDARD

The Highest in Quality
The Finest in Finish
The Best in Workmanship

ROY WATCH CASE CO.
21-23 Maiden Lane, New York City
SAN FRANCISCO, CAL. LONDON, ENG.

Learn Watchmaking
Refined, profitable labor. Competent men always in demand. We teach it thoroughly in as many months as it formerly took years. Does away with tedious apprenticeship. Money earned while studying. Positions secured. Easy terms. Send for catalogue. Address
St. Louis Watchmaking School, St. Louis, Mo.

WATCH REPAIRING FOR THE TRADE
Careful, Reliable, Prompt Work. Trade References. Price List on Request.
A. D. PAPAIZEN
71-73 Nassau St., Cockroft Bldg. NEW YORK

TIFFANY ELECTRIC CLOCKS

NO SPRINGS NO WEIGHTS NO CLEANING NO OILING



STYLE No. 1
Also Other Styles

350 JEWELERS—ATTENTION 350

In New York, Pennsylvania, Ohio, Indiana, Illinois, Iowa and Michigan we have given, in over thirty cities in each State, the exclusive sale of our Mantel Clocks to leading Jewelers in their respective cities. We also have such an arrangement with Jewelers in every State in the Union. As we sell *direct to the Jewelers*, there are *no cut prices*.

It pays 350 Jewelers to deal with us in this way and is worthy of your consideration. For prices and other information, write

TIFFANY ELECTRIC MANUFACTURING CO.

Manufacturers of Tiffany Electric Clocks

General Offices and Factory, 437-453 ELEVENTH AVENUE, 36th to 37th Sts., NEW YORK, N. Y., U. S. A.

Buy Watches With Our Patent Ball-Bearing Bow

Already on the Market

No watch case should be without it.

BEWARE OF IMITATION



Should your jobber not sell cases with these bows, write us and we will give you a list of jobbers who do.
Patented July 25, 1905; May 21, 1907. Other patents applied for.
Patented in foreign countries.

The Wachter Manufacturing Co.
HARTFORD, CONNECTICUT

HERMANN GRABEMANN
Reliable Watch Repairing
My work you can call your own
Trade References furnished A trial solicited
81 NASSAU ST., NEW YORK

JULES JÜRGENSEN
Watches and Chronometers
PARIS—"THE GRAND PRIX"—1900

SOLE
RUDOLPH & SNEDEKER
65 Nassau St., New York
AGENTS



STORE KEEPING DEPARTMENT

That this department shall prove mutually beneficial to our readers, it is desirable that the members of the trade generally communicate with THE JEWELERS' CIRCULAR-WEEKLY regarding any advantageous device or plan which they are utilizing in connection with their business.

STATIONERY SELLING *by* RETAIL JEWELERS

Written Expressly for the Jewelers' Circular-Weekly by Frank Farrington
(Continued from issue of Jan. 29.)

DON'T be too business-like in this ad. Remember you are sending it to women whom you want to interest. Let the text appeal to them by suggesting possibilities in the way of stationery which will show good taste and excellent form and represent what is best described by that overworked word, "swell."

Above all things avoid the stereotyped forms in the ad. and say things in a way that will get a hearing without any possibility of offending. To put a cheap ad. in one of these attractive envelopes, which will look on the outside like a note or an invitation, would be an invitation, indeed, to the failure of your scheme.

If you are going to get a woman to open the envelope in expectancy, see to it that you do not let her expectancy go entirely unrewarded.

By using a larger envelope you may include in this announcement of your stationery department a sample of some new and fashionable paper. The manufacturer will supply these to you without cost and probably inprint them for you. This will at once tell of the new stock and give a sample of its latest style.

Do not stop with this first announcement of your new departure. Too many dealers put in a new kind of goods and make a splurge over the fact, only to drop it there, expecting the business to come right along and take care of itself. One score won't win the game. When you have made a start, follow it up with the best plans you can afford to use.

The Formal Opening.

A stationery opening is a good way to introduce your new line of goods. You may let these little envelopes which are sent to the ladies carry invitations to this opening instead of advertising matter.

For the opening spread the stationery stock all over the store. Put open stock on all the show cases. Do this so that no one can come in without seeing what you are up to and so that no one can come in to see the stationery without seeing other things. Don't forget at any time that the reason you put in stationery was more to help sell the jewelry stock than to make a profit on the stationery itself.

At your opening give away some little

stationery souvenir—a pretty blotter, penholder or some little writing desk novelty—which you can buy cheaply in large quantities. Don't start in with a special sale at which you show your new goods for less prices than you expect to sell them later. Make the prices regular, this time.

After the first announcement, use the newspaper space to talk about your "swell" stationery and send out more direct advertising. Get up a neat post card of the store or of a stationery display and mail it.

When you get in some new papeteries, send out written invitations, telling about it. Make it a point to have your clerks call attention to the stationery stock when customers for other articles come in.

Engraving.

A line that is taken up by many jewelers who do not even carry box papers is the card and invitation engraving work. The store that sells writing papers will get more business in this work than the one that does not carry stationery.

The sale of engraved cards, etc., does not involve the outlay of any capital for stock. Simply make arrangements with some first-class engraver to do that work for you and then lay out your line of sample cards and invitations and you are ready for business.

It will pay to give this line of work attention in your advertising and make arrangements to file away the plates for your customers.

A System of Keeping Plates for Patrons.

People who order visiting cards like to be saved the trouble of keeping track of the plate. Arrange a simple filing plan and keep the plates for them without charge. This will be no expense and will ensure their return to you for the next order when the supply runs out. Many ladies use the same plates year after year, and this makes a steady business with no capital invested.

Look after the business of graduating classes and other organizations which occasionally use engraved invitations, and you can make a good profit out of them. It is worth while to make an arrangement with some house which does printing of that sort, as there are many cases, especially when a large number of invitations are to be used, when a printed job is desirable

on account of the expense of engraving.

There is no side line which, taken altogether, works in with jewelry much better than stationery. If you have tried it unsuccessfully it may be that you have not followed the right methods. If you have not tried it at all, you may be sure that you have neglected what ought to prove a profitable departure. It can be made a winner in every jewelry store. Try it in yours.

[THE END.]

The Way of the Enterprising.

THE Hess & Culbertson Jewelry Co., St. Louis, Mo., has had on exhibition for the past week an attractive display of watches and materials of the Illinois Watch Co. The window contains the products of a day's work of the factory, which employs 800 men. There are more than 500 watches of all sizes, varying from the lady's tiny watch to the Bunn special railroad movement. All of them were "alive," as the Scotch Highlander would say, and one of them was running without a hairspring in order to show the quality of the material used. Among the collection is said to be what is the only 25 jewel watch in the United States. All the material entering into the construction of a watch from its rough to its finished state is included in the display. In a small box are shown the 160 different parts of the watch, thus gratifying the longing of the curious to see a watch taken to pieces. The display includes 437,000 jewels, 5,000 center wheels, 10,000 balance staffs, 8,400 pellet jewels and innumerable hairsprings, pinions, ratchets, mainsprings, clicks and all the intricate parts of machinery that go to make up a watch.

Among the attractive folders issued for St. Valentine's Day this year is that of Ryrie Bros., Toronto, Ont., which is gotten up in pamphlet style. The folder has a bright red cover, printed in gold. Illustrated by dainty half-tones are several low-priced articles suitable as remembrances, tokens, or prizes for card parties. Most of these little gifts are fastened with ribbons on neat heart-shaped cards bearing such inscriptions as "To my Valentine," "Valentine Greetings," etc. The prices range from 35 cents upward. It is to be regretted that the manner in which the gold is put on in the printing, and also the peculiar effect caused by the combination of gold and red, renders the rather interesting reading matter on one side of the folder's cover very difficult to read. Distributed with the folder is a Valentine order sheet.

Storekeeping Department.

The Economy of the Trade Journal.

It may be the belief of some that the trade journal is a necessary evil, says the *Textile American*, to be tolerated by the manufacturer as a mild form of commercial blackmail, while doing a moderate amount of good in telling him what he already knows, or offering him a medium whereby he may inflict his notions on a long-suffering public.

It is probably a fact that all the leading trade journals dealing with a particular industry reach the office or reading-table of every up-to-date manufacturer. They are looked over, some article of especial and personal interest is examined and in the rush of daily business the issue becomes forgotten and is laid aside, in time to swell the bulk of the waste heap.

Such treatment should not be accorded any reputable journal of any industry. Each issue should be considered by the manufacturer an investment, or a means of increasing the efficiency of his plant; it might be called an improved machine or an improvement on the machinery of the plant, for the visit of the issue should not end with the table of the manager; once read by him, its contents should be noted and by a simple plan of circulation, be sent traveling through the departments to be read by the heads, especial attention being called to matters of peculiar interest, then passed along till it has traversed through the factory, returning to the office as proof it has been doing missionary service.

Nor should its circle of circulation be limited to the heads of departments; the man on the machine should be interested to see what someone else has decided on the matter which interests his work, and the career of the issue of a journal will be so enlarged as to make it necessary for more than one copy of the issue to be set in motion.

The influence of the trade journal should not be limited to the study of the

more active and efficient, producing equally marked results, and possibly results which will make more valuable the service of the tools.

A New System of Illumination.

ALTHOUGH incandescent lamps have been greatly improved from time to time, no radical change has been made in the shape of them since their introduction. A new system of lighting has now been devised, known as the linolite system, which

size and length of filament and consuming the same current. This curve is the result of a certified test made by the city and guilds of London Institute, London, Eng. The block curve shows the candle-power in any direction of the bulb lamp, while the dotted curve shows the corresponding values of the candle-power by the linolite. It is notable that while the illumination given by the bulb lamp immediately in front is seven to eight candle-power, that of the new light is over 40 candle-power.

It is particularly adapted for lighting

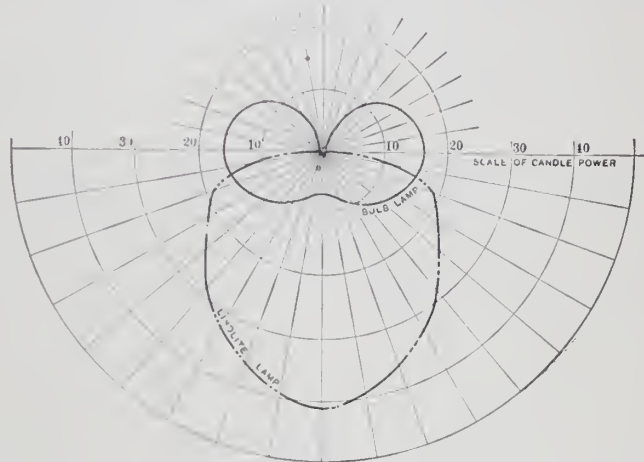

FIG. 1.

employs a long tubular lamp in which the filament reaches from end to end. As the name implies, there is formed a continuous line of light, the lamps being connected end to end. The source of light being continuous, the illumination is uniformly distributed, and alternate bright and dark spots are claimed to be eliminated.

The lamps are arranged in a semicircular reflector which is made up in any lengths required up to and including 10 feet. The position of the lamp relative to the reflector is such that the filament is located uniformly throughout its length in the focus of the reflector, and thus a maximum of reflecting efficiency is obtained. It is

show windows, show cases, etc., and the outlining of buildings for display purposes. An important application of it is in the illumination of room interiors by reflected light, in which case the tube is placed above the cornices near the ceiling, from which the light is reflected.

Keep Old Advertisements.

ARE you a regular advertiser, and if so, do you keep a faithful record of your advertisements? A scrap book in which each advertisement is pasted is a valuable addition to your list of helps.

The first good effect it has is as a con-



FIG. 2.

claimed that the illumination secured by this new system is much greater than that from an ordinary bulb lamp (Fig. 2).

Another advantage is the small space which it requires. The entire reflector is only 2 1/4 inches wide by one inch deep over all, so that it can be placed in show windows, show cases, etc., back of the window frames or fillets, in such a manner that the fixture will be invisible or practically so, and the source of light screened entirely from the eye of the spectator. The common defect of systems using bulb lamps for illumination is that the spectator is usually dazzled by the light from the lamps themselves.

Fig. 1 shows the distribution of luminous intensity of the new light as compared with the ordinary 16-candle-power lamp in its end-on position, both having the same

stant reminder. If each ad. as it comes out is pasted in a book there will be little danger of your advertising matter becoming stale; it will in itself urge upon you the necessity of keeping fresh copy in the hands of the printer. In making up the monthly schedule of advertising the scrap book of the corresponding season of the year or years before will be suggestive of the proper things to push and give a fresh inspiration very often for entirely new advertising matter.

Notations of after thoughts made in the margins, or ideas which might have been worked in to make the advertisements more effective and productive of better results will be most helpful during the following year. In presenting to view the entire scope of advertising matter, any existing weaknesses will be observed.

manager-subscriber. The thinking workman is what is needed in every industry and progression. Progress is not made in any art or science by the investigations of men in the places of command alone. Rare improvements in mechanical constructions have been made by those who in the economy of the establishment occupied but an inferior position, and the manager who recognizes the power of his employes to be of indirect assistance to the business by keeping their eyes open for improvement, is developing a higher grade of employe, and enlisting in his service men of wide-awake minds. The tools and utensils of the craft are put in the hands of the workmen by the management, and they are expected to be wielded with fixed results. In the same way tools of thought should be provided that the minds may be rendered



HERPERS BROS..

MAKERS OF

"SWASTIKA"

SETTINGS

IN 10, 14 AND 18 KARAT GOLD AND IN PLATINUM

ALSO A COMPLETE LINE OF GALLERIES AND FINDINGS

Plain and for Enameling IN THREE SIZES

OFFICE AND FACTORY NEWARK, N. J., U. S. A

NEW YORK BRANCH 41-43 MAIDEN LANE

JANITSCHKE COMPANY, Inc.

33 UNION SQUARE, NEW YORK CITY

Manufacturers of Patented **DIES** for the Silver and Metal Trade

ARTISTIC CASTINGS OF EVERY DESCRIPTION FOR THE SILVER AND JEWELRY TRADE

Iron Hubs and Bronze Forces, False Core Work and Undercut Castings with Elastic Patterns. Fine Plaster Castings by the *Janitschek Patent*

TELEPHONE, 400 STUYVESANT



JOHN AUSTIN & SON

Assayers, Refiners and Smelters

74 & 76 Clifford Street PROVIDENCE, R. I.

We Do Our Own Smelting.



L. LELONG & BRO.

Gold and Silver Refiners, Assayers and Sweep Smelters

S. W. Cor. Halsey and Marshall Sts., NEWARK, N. J.

Prompt attention given to Gold and Silver Bullion.

SMELTING FOR THE TRADE.

OUR BUSINESS

Established and in business since **1894**

DIES

We have been giving satisfaction for the past 14 years.

FINE DIE WORK IS ESSENTIAL FOR FINE JEWELRY, SILVERWARE, ETC. Write us and let us submit for your approval a selection of original designs, made especially to suit your needs.

CREES & COURT Die Sinkers and Designers
21 Eddy St., PROVIDENCE, R. I.



A Small Compound Sand Blast

Price, \$20.00 Foot Bellows, \$6.00

WORKS AS EFFECTIVELY WITH FOOT BELLOWS AS WITH POWER BLOWER : : : :

MADE of Galvanized Sheet Iron, 10 inches diameter, Glass Top, Fittings of Brass and Iron, practically indestructible. Satisfaction guaranteed. Ask your Jobber for it, or write to us. Other Specialties: Zeuner's Best Jewelers' Saws; American Swiss Files, equal to the best imported; Gas Furnaces, for Melting, Annealing, etc., etc.; Positive Pressure Blowers.

E. P. REICHHHELM & CO.
JEWELERS TOOLS, FILES AND SUPPLIES
24 JOHN STREET, NEW YORK

Importer and Manufacturer of WATCH MATERIALS, TOOLS, JEWELERS' SUPPLIES AND OPTICAL GOODS

Bargains in Engraving Blocks



Prices on Application

Fine Gold, Silver and Platinum always on hand. Highest Prices paid for Old Gold and Silver.

A. ZAREMBOWITZ
250 East Houston Street NEW YORK

J. H. GALAWAY P. M.

ENGRAVERS

CRESTS, MONOGRAMS AND LETTERING

7 Malden Lane, Rooms 44-41

Established over 35 years



WORKSHOP NOTES AND QUERIES.

[Answers are also solicited from our readers to the questions published on this page.]

QUESTION No. 2071.—Bleaching Pearls.

—I have some fine pearls that I want to bleach. How can I do this? B. P.

ANSWER:—In order to bleach pearls that are mounted, immerse for some time in concentrated javelle water. The metal will be cleaned at the same time. Then rinse several times in clear water and dry in sawdust. Unmounted pearls are treated in the same manner. Oxygenated water (hydrogen bioxide) may also be used. It is best to thoroughly wash in soap and water after the articles have been well rinsed.

QUESTION No. 2072.—Nickeling Preparation.

—There is a preparation vended on the streets in small bottles, which, if applied to any brass article, will give it the appearance of nickel-plating. I believe this is a mercurial preparation of some kind, and would ask you to kindly advise whether you can give me the formula for this or some similar preparation. A. C.

ANSWER:—Most of the preparations sold by the street vendors for silvering or nickeling brass or any other metals are mercury amalgams, and are of no use as far as durability is concerned. The application will look well for a day or so, then will lose its luster and become tarnished. Solutions for silvering by applying with a cloth are made and will give better results if the principal ingredients are chloride of silver, which makes the solution somewhat expensive, and the application will cost nearly as much as an electro-deposit. Following are several formulas that may be used. All metals to be treated should be made as clean as possible before applying the tincture. (1) For silvering wood or metals: Melt 24 grammes of pure tin in an iron ladle and add the same quantity of bismuth. Stir with an iron wire until all is melted. Take from the fire, add 24 grammes of mercury, mix thoroughly and pour into a porcelain dish to cool. Dilute with the white of an egg and alcohol, to which has been added a little gum arabic. Put in a bottle. It is used by rubbing on. Afterwards it can be polished. (2) A silvering solution used by merely rubbing on is composed of chloride of silver, two parts; cream of tartar, two parts, and enough water to make a thin paste. Bottle up for use. This works best if used hot. Apply with a rag or sponge. (3) Cyanide of silver solution, rich in silver, two ounces; whitening, one ounce. Put both in a bottle and shake well before using. (4) This is a solution that contains no silver, but will work best if the pieces be immersed in it in place of applying with a sponge or cloth. First clean the metal pieces by immersing in hot

potash, then rinse in cold water. Now place the article in a regular copper solution, attaching leaves of zinc. They will assume a red tint. Pass them into a nickeling bath made as follows: Cream of tartar, 20 grammes; salammoniac powder, 10 grammes; kitchen salt, five grammes; oxychlorhydrate of tin, 20 grammes; sulphate of nickel, single, 30 grammes; sulphate of nickel, double, 50 grammes; water, one quart. Remove in a few minutes, then rub with a moist cloth. (5) This is an amalgam used by rubbing on with a cloth: Mercuric nitrate, $\frac{1}{4}$ ounce; sulphuric acid, $\frac{1}{2}$ ounce; water, $\frac{1}{2}$ pint.

QUESTION No. 2073.—Aluminum Solder.—Can you tell us how to make a good solder or solution to use on aluminum?

H. B. & Co.

ANSWER:—(1) Zinc, by weight, 90 per cent.; aluminum, 5 per cent.; antimony, 5 per cent. The aluminum is first melted in a crucible and the zinc added gradually. When the latter is melted the antimony is put in and the alloy mixed intimately with salammoniac. When the surface of the molten metal is clear and white the slag is removed and the solder cast in bars. The surface to be soldered is first cleaned with acid and then coated with solder, care being taken that the latter penetrates the surface of the metal under action of the fire without being burned. The pieces are then brought into contact and heated, the excess of solder is removed while still in the liquid and the whole allowed to cool. (2) A solder said to be effective consists of a soldering salt which may be used either alone or in combination with a metal, or rather with a metallic solder, whose fusing point is less than that of its alloys. This soldering salt is a mixture of sodium chloride, zinc chloride and cadmium chloride, which are wasted or melted and ground to a fine powder, after having been cooled. This powder may be employed alone. It is placed on the surface to be soldered, and the operation may be conducted with the blow-pipe, as usual. But in many cases it is necessary to employ a metallic solder at the same time. The metallic solders are formed by metallic alloys whose fusing point is lower, as said above, than that of aluminum and its alloys. Such an alloy as solder may be obtained from aluminum, tin, zinc, cadmium and lead, which are mixed in suitable proportions, melted and cast in small pieces for the solder. The suitable proportions for the mixture are the following: One part of aluminum, five parts tin, five parts zinc, five parts cadmium and one-half part lead. In place of aluminum an alloy of metal may

be employed, such as the alloys of nickel, aluminum or magnalium, which would not render the solder sufficiently fluid. The solders are preferably employed by mixing the ground metallic solder with the soldering salt in suitable proportions, placing the mixture on the surface to be soldered, and using the flame of the blow-pipe. The places united with these solders are clean, and the solder is permanent. To avoid disintegration of the solders, so much feared in the case of aluminum, the solders obtained in the manner already described are submitted to ulterior treatment in an aqueous solution of sodium hyposulphite, by exposing the soldering or the object soldered for an hour or more to the action of this solution.

Oxidizing Nickel Deposits.

NICKEL deposits are now produced of such whiteness that they closely resemble silver, and in many instances it is desired to oxidize it so that an imitation French-gray finish may be produced.

Nickel is not susceptible to the oxidizing agents employed upon copper, brass or silver, and the only method which is satisfactory for this purpose is to deposit another metal on the surface and oxidize it. The surface is then relieved.

In oxidizing nickel deposits by such a method, a copper deposit can be put on the nickel and then oxidized by liver of sulphur; but when the surface is relieved, the red edges of the copper become conspicuous.

By reversing the process, however, the operation becomes successful. The nickel is deposited upon the work in the usual manner and buffed or left dead as may be desired. If buffed, rouge and not Viennalime should be used, as the latter is difficult to clean from the surface. A flash copper deposit is then put on and the relieving carried out. The copper is thus removed from the "high-lights" of the article. After cleaning, the article is immersed in the regular liver of sulphur solution (2 oz. of liver of sulphur to the gallon and used cold). As liver of sulphur does not attack nickel, only the copper is blackened. In this manner the red edges are obviated.

Some excellent effects are produced by this method. The preliminary buffing may be dispensed with if desired, and the relieving operation used for "coloring." The operator may suit himself, however, in the matter. Some excellent dead effects may be produced by leaving the nickel as it comes from the plating bath. A white, even deposit must be obtained in this case, as stains become conspicuous on the finished object.—*The Brass World*.

A small lamp exploded in the store of A. C. Guth, Du Bois, Pa., about a week ago, and started a fire. The flames were extinguished before doing any serious damage.

Raphael Catterlin, Louis Loll, George Smith and Walter Oliver were arrested recently in Tillamook, Ore., on a charge of burglary. Loll and Catterlin were recently caught in the act of attempting to loot the store of Eugene Jenkins, a jeweler of that place.

C. DORFLINGER & SONS

36 MURRAY STREET

NEW YORK



Hand-Made Blanks only.
Cut, engraved and etched
glass. Light, medium
and heavy stemware,
tumblers, etc.

The Pairpoint Corporation

NEW BEDFORD, MASS.

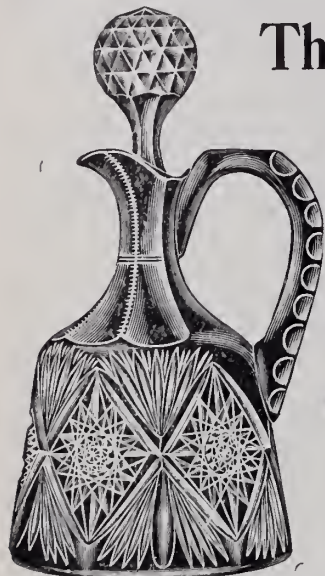

SUPERIOR
SILVER PLATED
WARE

RICH
CUT GLASS
WARE

ELECTROLIERS
GAS PORTABLES, ETC.



No. 4935.—Smoking Set.

BRANCHES

No. 692.
Whiskey Jug.
"Uncatena."

38 Murray Street - - - NEW YORK CITY
717 Market Street - SAN FRANCISCO, CAL.
485 St. Catherine Street - MONTREAL, P. O.

The St. James

Cor. Walnut and 13th Sts., Phila., Pa.

THE IDEAL HOTEL OF
THE QUAKER CITY

A spacious fire and burglar proof
safe has been provided for the con-
venience of the trade. Palatial
rooms with bath \$2.50 per day
and up. Rooms without bath,
(running water) \$2.00 and up.

EUGENE G. MILLER, Mgr.

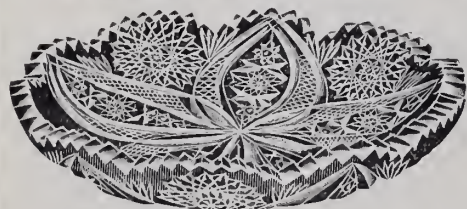

7-in. Saucer, Pansy No. 205

KELLY & STEINMAN, Inc.

Manufacturers of

Rich Cut Glassware

Is Quality any consideration
with you? If so, let us send
you a Sample Order.

OUR PRICES ARE MODERATE

KELLY & STEINMAN, Inc., HONESDALE PENNSYLVANIA



"Wild Rose," No. 122—14-inch
Ice Cream Tray

Irving Cut Glass Co. Inc.

Manufacturers of

Artistic Cut Glass

HONESDALE, PA.

F. W. REICHENBACHER
New York Representative 59 PARK PLACE

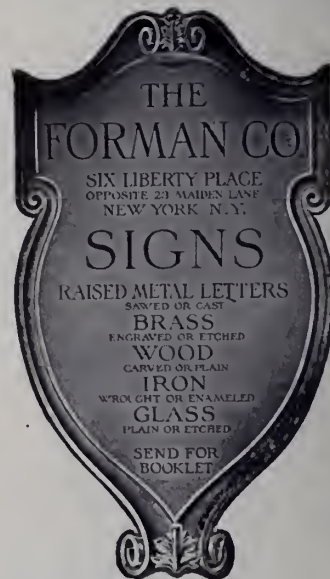

JACOT MUSIC BOX CO.,
IMPORTERS.

Stella and Ideal Music Boxes.
39 UNION SQUARE, N. Y.

PLATINUM AMERICAN PLATINUM WORKS NEW YORK OFFICE 41 Cortlandt Street NEWARK, N. J.

THE CONNOISSEUR

Devoted to Art Pottery, China, Marbles, Bronzes, Cut and Decorated Glass Ware, Bric-à-Brac, Lamps, Art Metal Wares, Fancy Goods and Kindred Lines.



A Few Words on Nymphenburg Porcelain.

THIS porcelain factory of the prince elector of Bavaria, established about 1747 at Neudegg in the Au, by deserters from Vienna, under Johann Niedermayer, at first labored under the same disadvantage as Fürstenburg; no porcelain pieces could be completed. When success was finally attained the Prince-elector Maximilian Joseph III. in 1761 transferred it to Nymphenburg, where it developed rapidly. During the period from 1764 to 1766, for instance, it had on an average 300 work-people; but,

by its gray, and sometimes even yellowish, color. In regard to the form of the vessels, we encounter only that which was in vogue at the time, but the decoration invariably displays one peculiarity, viz., something notably severe and heavy. Elegant scattered flowers are never to be seen; broadly disposed away from the center, a large, clumsy spray of flowers and large flowers and butterflies are scattered crudely, close together, over the surface. This causes the decoration to assume a crude, confused, op-

ladies in the most varied and exceedingly coquettish, elegant, dainty and captivating poses, also a number of groups of frisky cupids, allegorical groups and genre figures, in accordance with the taste of the times, which the Nymphenburg modelers, headed by J. Auslizek (who worked from 1765 to 1772, and later Johann Peter Melchior (1796 to 1822), have modeled in inimitable, sparkling vivacity of conception, originality of design and exquisite execution. In this manner Nymphenburg figurative art exists as one of the, even if minute, worlds of miniature sculpture, which, if they do not attain to the importance of Meissen, are still something in art; they lose nothing in effectiveness by the peculiar grayish white of the mass. Our illustration shows two busts, representing Winter and Summer, in this ware, the distinctive mark of which is the Bavarian rhomboidal shield.

Calais Invites American Participation in a Great International Exposition.

OUR Consul at Calais, J. B. Milner, reports that he recently received notice from P. Meriat, director general, of the holding of an international exposition at Calais; a translation of the communication reads:

The municipal council of Calais has voted the installation in this city of a great international exposition, which will last from April 19, 1908, to the first Sunday of next October, and will include all branches of industry, commerce, agriculture, science and fine arts. It is directly placed under the high patronage of the French Government, the municipality, and the chamber of commerce of Calais.

By reason of the exceptional situation, so near to England and Belgium, Calais is the starting and landing place of daily passenger boats, which assures to Calais the presence of a large number of visitors. Besides its privileged geographical situation and its ever flourishing commerce, Calais boasts of a renowned industry, which in later years has gained such an importance that it is for us the firmest guaranty of a pronounced success.

We take the liberty of calling your attention to this really exceptional situation, and at the same time of requesting you to inform us if you desire to figure among our exhibitors. We hope that such will be the case, and we forward you, under the present cover, a form of request for admission, holding ourselves at your disposition to forward you on request all necessary information.

This will present a good opportunity to show American-made and up-to-date commodities, and it will also be an opportunity for sections of the United States which desire to induce desirable immigrants to settle in their territory. Already a number of governments have signified their intention to participate in the exposition, and Director Meriat recently called at this consulate and requested the participation of the American government.

A plan and a copy of the rules and regulations of the exposition are filed with the Bureau of Manufactures, Washington, D. C.



BUSTS "WINTER" AND "SUMMER," NYMPHENBURG PORCELAIN.

owing to the fact that no favorable outlet could be opened up for its productions, it steadily lost ground until, in 1862, it was abandoned as a royal enterprise. It never succeeded in existing without a subsidy, and even during the most flourishing '60's the "National Porcelain Manufactory" drew every week a subsidy of 1,000 florins from the treasury. The Nymphenburg Royal Porcelain Works is nevertheless still in operation, and of late marked progress has been ascribed to it.

The Nymphenburg "mass" is of very mediocre quality; it is, indeed, recognizable

pressive and inelegant appearance. Some pieces are decorated in relief, which is transformed gradually into painting. Thus the handle of a dish is often formed of a blossoming vine that is continued in painted form on the surface. We thus have, on porcelain, to a certain extent the inception of our panoramic decoration. This also, says Lehnert, is an error in art.

On the other hand, the figures, under the influence of the Rococo style, which at that period prevailed throughout South Germany, attained extraordinary beauty. Above everything else, there were cavaliers and



**Buckles
Clasps
Belt Pins**

Artistic, But Inexpensive

PRODUCTS OF

The "Apollo Studios"

WILL INCREASE YOUR
SPRING SALES

Bernard Rice's Sons

544 BROADWAY

Works and Studios 4-6 Marion St. 205-207 Lafayette St. **NEW YORK**



No. 471—ELECTROLIER

(Patent applied for)

Copper Bound, Leaded Glass Shade

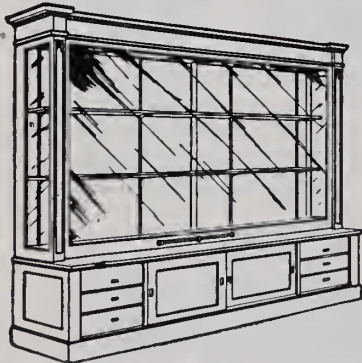

Jewelry Store Fixtures and Show Cases

OUR SPECIALTY

The enlargement of our factory in our new location enables us to quote low prices.

If you need fixtures or show cases let us hear from you. Estimates cheerfully furnished.

ALEXANDER H. REVELL & COMPANY, Rees, Dayton, Eastman and Hawthorne Sts., CHICAGO, ILL.

Established 1879

Manufacturer of

LOUIS W. HRABA Fine Leather Goods

29 East 19th St., New York

Exclusively for the Jewelry Trade

ESTABLISHED 1886

GEO. M. BAKER

TELEPHONE UNION 1493-R

Gold and Silver Refiner and Sweep Smelter

Office, 91 Page St. }
Works, 77-85 Page St. } **PROVIDENCE, R. I.**

Our processes are strictly up to date and facilities most complete for doing all kinds of refining. Specialties: Prompt and good returns.

CROUCH & FITZGERALD



Jewelry Trunks and Cases

177 Broadway, Bet. Cortlandt and Dey Sts.
688 Broadway
723 6th Ave.,
New York.



LEMAIRE OPERA GLASSES

LEMAIRE FIELD GLASSES

Best in the World. Used in the Army and Navy.

SUSSFELD, LORSCH & CO., Importers

37 MAIDEN LANE, NEW YORK

MARQUE DE FABRIQUE



All Genuine Glasses
Bear This Mark
Large Variety in All
the Latest Styles

Peking Cloisonné Ware.

THE following report on the subject of the Chinese manufacture of cloisonné at Peking is transmitted by Consul Wilbur Gracey, at Tsingtau, to the Department of Commerce and Labor.

Probably the finest quality of cloisonné now manufactured is that which comes from Peking. The Industrial Mission Depot, a branch of the Peking Industrial Institute, has recently been opened at Shanghai, where a large supply of cloisonné is always on hand, and where vases, bowls, jars, plates, boxes, incense burners, water pipes, umbrella handles, cigar boxes, napkin rings, etc., can be purchased at any time. Goods are packed by its depot and shipped to all parts of the

These consist of crystals with a base of saltpeter and a kind of calcareous sandstone found in the neighboring hills. The different colors are obtained by composition with iron pyrites, oxides of iron, or salts of lead. The colored crystals, ground to a powder, are mixed with rice water, and the resulting paste forms the base of the enamel. The colors are applied by means of a small trowel, and the operation calls for great skill and dexterity.

"When all the spaces are filled the vase is again baked in the oven for a certain number of minutes, as decided by the expert in charge of this operation. When cool the vase is smoothed off with a file and returned to the coloring room, where all defects are made good. In some cases several of the spaces must be done over



ORIGINAL DESIGN FOR A SILVER PUNCH BOWL.

world. The cloisonné exhibit of the Peking Industrial Institute was awarded a gold medal at the St. Louis Exhibition of 1904.

The following quotation regarding the manufacture of this ware will be of interest:

"The base, whether vase, bowl, or dish, is of copper and is obtained ready made from the coppersmiths. The design is then etched on the copper base, and delicate copper ribbons are shaped by means of pliers to follow the lines of the design. These are cemented into position by means of a special vegetable glue, fortified by a metallic composition, which maintains the shape of the wire tracery while it is being annealed in a primitive oven surrounded by a wire cage containing charcoal, which is kept at a red heat with fans.

"When cool the vase is scoured in an acid decoction and is then ready for coloring. An artist, supplied with a number of saucers containing all the colors he requires, takes the vase, and, from memory, and without reference to any illustration, fills in the interstices between the wires (the cloisons) with the proper pigments.

again; the solid vitreous color is chipped out and the cloison re-filled with paste.

"The vase is again baked and polished, this time with limestone, on a lathe. The retouching, rebaking and polishing are continued until the desired result is obtained. The final lathe polishing is done with charcoal.

"The vase is then ready for gilding, which is done by an ordinary galvanic process and a final polishing renders the article ready for the market."

An Original Design for a Silver Punch Bowl.

THE original design for a punch bowl which appears on this page was submitted by Frederick G. Jones, 358 Henley St., Brooklyn, and is published for the use of our readers generally.

The design is in the Renaissance style and is of simple yet graceful proportions, the ornamentation being confined to a frieze of repoussé work, showing flowers, swags and masks bordered with the reed and ribbon, which also ornaments the base and handles.

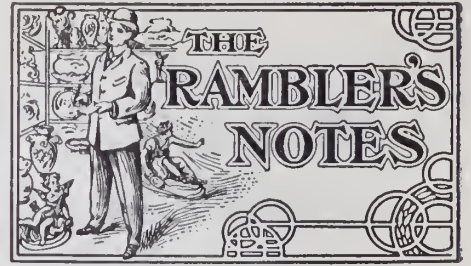

CUT GLASS IN MANY FORMS.

LING & STEWART, 68 West Broadway, New York, have recently

become the New York representatives for the Herbeck-Demer Co., cut glass manufacturers, Honesdale, Pa., and now have on exhibition at their salesrooms a full new line of this glass, which is sure to please jewelers visiting New York in search of novelties. An attractive piece is a combination fruit dish and compote. The compote forms the base and standard of the fruit dish, on which rests a separate dish or receiver. The two pieces can be used as one dish or the upper dish can be removed and a dainty compote and fruit holder are ready for use. The cutting on both pieces is elaborate, and on the fruit dish are slits grooved into the sides, producing a most pleasing effect. This new line also contains a fine collection of vases in several patterns and styles of cutting, one of which has a rounded base supporting a short standard from which rises a cleverly shaped body. A boat-shaped celery dish is elaborately cut in dainty pattern, while a sugar and cream set cut partly in finely-woven lattice work effect will also attract attention. Water pitchers, wine decanters, small heart, boat and diamond-shaped trays, as well as dainty compotes are among the other attractive offerings of these salesrooms.

*

CLOCKS IN ATTRACTIVE FORMS.

AN attractive clock set recently placed on exhibition at the salesrooms of

Harris & Harrington, 12 Barclay St., New York, is made up of a center piece mounted on an oblong base of white marble embellished with gilded work. On the base are two small pedestals on which are seated two feminine figures, and between them is a standard in the body of which is the clock. Each woman is resting a hand against the standard, one looking upward, while the other watches a chubby cherub, who is approaching her with outstretched arms. The body of the central standard is decorated with a wreath worked in gilded effect. Another attractive clock at the same salesroom is of metal and represents a battleship full-rigged and ready for action. At the side of the miniature ship hangs an anchor, and on one of the funnels is a thermometer, while on the other is a small barometer. The clock is in the turret. At one end is the steering wheel, while in the other turret is a compass. This is a most attractive and novel offering, and its beauty is enhanced by the fact that it is mounted on a green onyx base.

THE RAMBLER.

'Phone 3759-R.

WM. F. RENZIEHAUSEN CO.

43-47 Oliver Street, NEWARK, N. J.

Gold and Silver Refiners

PROMPT RETURNS MADE FOR ANY MATERIAL CONTAINING PRECIOUS METALS
DEALERS IN GOLD AND SILVER, AND ROLLERS OF STERLING SILVER

Gold and Silver Anodes a Specialty



WE BUY

Old Gold and Silver Filings, Polishings, Sweeps, Hand Washings, etc. We will make accurate valuations and hold consignment subject to your acceptance. If valuation is not satisfactory, we reship to you at our expense.

WE PAY FOR OLD GOLD:

22 K. 88c. per dwt.	12 K. 48c. per dwt.
20 K. 80c. " "	10 K. 40c. " "
18 K. 72c. " "	8 K. 32c. " "
16 K. 64c. " "	6 K. 24c. " "
14 K. 56c. " "	4 K. 16c. " "

MARKET RATES FOR SILVER AND PLATINUM.

Try us and you will Appreciate our Squareness, Promptness and Accuracy.

T. B. HAGSTOZ, Ltd., Main Office, 709 Sansom St., Philadelphia, Pa.
SMELTERS, ASSAYERS, REFINERS.

WE SELL

Gold, Silver and Platinum, various qualities, rolled flat or drawn to wire of any gage.

PRICES OF ALLOYED GOLD:

8 K. 42c. per dwt.	14 K. 66c. per dwt.
10 K. 50c. " "	16 K. 74c. " "
12 K. 58c. " "	18 K. 82c. " "

Gold and Silver Solder, either from formulas furnished, or our own. "T. B. H." Alloy, 25c. per oz. Guinea Gold, 75c. per lb. Shot Copper, 40c. per lb. We will send tables for alloying without charge. They save figuring.

WHY NOT SEND YOUR SWEEPS DIRECT TO THE SMELTERS?

LEES & SANDERS, BIRMINGHAM, ENG.

Our plant is right up-to-date and specially arranged for smelting jewelers' sweepings

SEND ON AN ENQUIRY FOR REFERENCES ON YOUR SIDE.

ESTABLISHED IN 1870.

BUY

CUTTLE FISH BONE

The mark P-E-A-CO. insures quality. Secure our prices before buying elsewhere; it will pay you.

P. E. ANDERSON & COMPANY

IMPORTERS 7 @ 13 GOLD ST., NEW YORK CITY

CRUCIBLES.



Jewelers' Supplies,
Etc.

Established 1850.

J. & H. BERGE,
95 John Street,
NEW YORK.



CASTINGS Gold, Silver, Bronze, Brass, German Silver, Copper and Iron.

L.D. TEL. 2072 L. Supply Jewelers, Silversmiths, Die-makers, Mould-makers, etc. Bronze Forces, Hard Bronze and Iron Shells for Die-cutting Machines. Cast Iron Hub for sinking in Steel Dies. Chandler Undercut Work, Statuary.

AUGUST GRIFFOUL 313 HALSEY STREET
NEWARK, N. J.

UNITED STATES SMELTING AND REFINING WORKS

L. & M. WOLLSTEIN

16 JOHN STREET, NEW YORK

SWEEP SMELTERS AND ASSAYERS

Dealers in Gold and Silver Assay Office Bars. HIGHEST and MOST PROMPT RETURNS made for Sweeps and all kinds of Waste containing precious Metals.

HIGHEST PRICES PAID FOR OLD GOLD AND SILVER

Manufacturers of STERLING SILVER.

Importers of PLATINUM.

Ore and Bullion Assays a Specialty.

The Ackley Engraving Block

AND "JOKER" ATTACHMENT



Pat. March 20, 1906

Made by Engravers who saw the need of a Handy Time Saving Block

THE BEST IS THE CHEAPEST

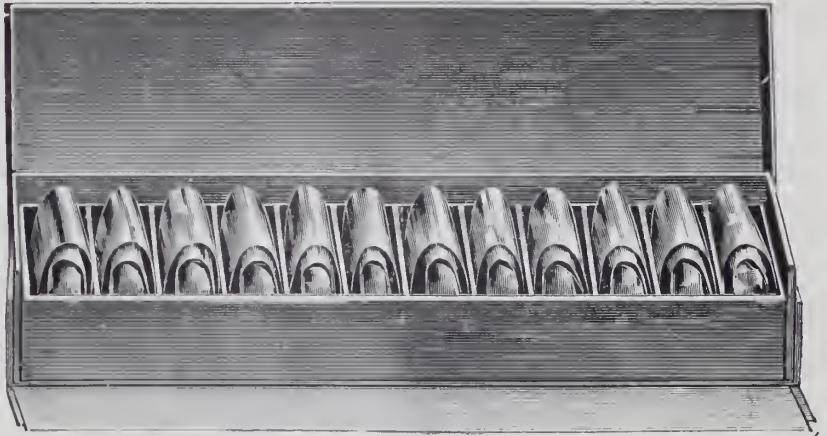

Why the "LAFAYETTE MAINSPRING" is superior

1st—It is guaranteed to be made of the Best Steel. 2d—It is made by Skilled Hand Labor. 3d—Each Spring is wrapped in Oil Paper and Silver Foil, which packing positively avoids exposure to the moisture of the air, and therefore all danger of rust is prevented. 4th—Each Spring bears a metal Tag, indicating the watch it is intended for, which accuracy is warranted. 5th—Each dozen is put up in a neat Box, having twelve partitions, one for each spring, so the handling of several springs at one time is avoided. 6th—The finish of the "Lafayette Spring" is, like its quality, superior to any in the market.

THE ACKLEY ENGRAVING BLOCK: Always ready to hold any article. No hunting for pins. The patent friction pins all remain in the head. Simply pull up to the desired height the ones needed. Each pin is numbered on top to designate size of groove or notch in it. They are so arranged in the head that they will readily hold all large or small articles either by three or more points of contact. The swivel jaw can be locked rigidly in an instant. The key will not fall off, yet it may be removed instantly. The patent base eliminates all unnecessary weight and gives the same movement as the old ball and socket base. This block is the result of years of practical experience of engravers who know the wants of engravers. There is nothing complicated about it to wear out or get out of order. Workmanship and materials are the best. Each part is copper plated before being heavily nickel plated, thus insuring a fine durable finish. Height, 6 3/4 inches. Diameter of head, 2 5/8 inches. Diameter of base, 6 inches. Weight, 8 pounds. THE "JOKER" ATTACHMENT, as shown beside the block, holds large and small signet and band rings, cuff buttons, collar buttons, signet pins, etc., firmly, without marring. It may be used on any block.

HENRY ZIMMERN & CO., Inc., 77 John Street
New York City
Exclusive Wholesale Distributors for U. S. and Canada

Practical Course in Adjusting

By THEO. GRIBI,

COMPRISING

A review of the laws governing the motion of the balance and balance spring in watches and chronometers, and application of the principles deduced therefrom in the correction of variations of rate arising from want of isochronism, change of position and variation of temperature.

ELUCIDATED AND DEMONSTRATED

by original experimental researches in the actual problem, never before published, showing the causes that are operative in the variation of rate, and leading to correct remedies. To which have been added chapters on

How to make a Balance Arbor with Modern Appliances; How to Clean a Watch Properly; and, the Lever Escapement—Some Current Defects in it and How to Remedy Them.

Published Price, \$2.50.

SPECIAL REDUCED PRICE, \$1.50,

Post prepaid.

250 pages, including 18 diagram plates; Fine Paper; Large Type; Clear Illustrations; Systematically arranged; Solid Binding.

THE JEWELERS' CIRCULAR PUB. CO.

Publishers

11 John St., cor. Broadway, New York.

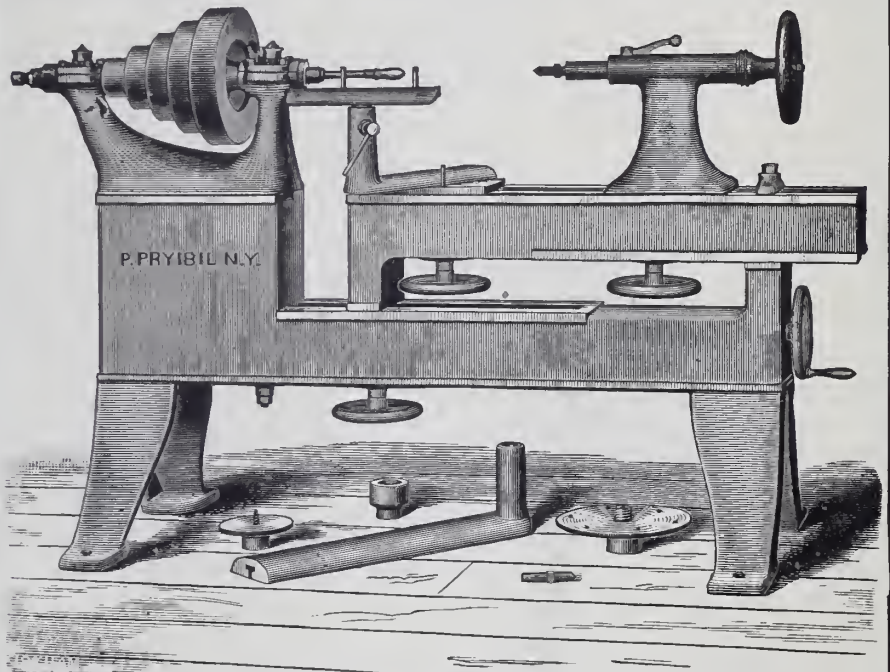

Above Cut Shows Our

EXTENSION SPINNING LATHE.

Swing of lathe 22 inches when closed, 44 inches when extended.

Substantially built for heavy work.

Write for Catalogue

P. PRYIBIL, 512-524 W. 41st St., New York.

A Few Words About Mainsprings



There is no article of material used by the watchmaker or the watch repairer about which, if he be a careful and thorough workman, he feels more solicitous than the *Mainspring*. Next to the fragile watch glass, the mainspring is more frequently replaced than any other article used in watch repairing. While the percentage of breakage is high in all watch springs, it jumps into appalling proportions when they are of an inferior quality, unless their temper is so low as to make them almost useless, and certainly of little value in watches that are to serve the purpose of timekeepers. When we offer you the *Ulysse Sandoz Robert* spring, we feel confident that you are getting the best that skillful hands and lifelong experience can produce.

Made for all American Watches. Per dozen, \$1.25

The Ely Watch Protector

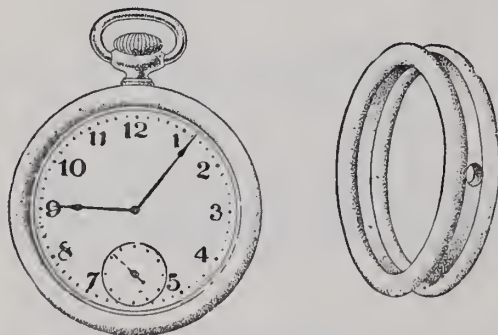

Designed to give the maximum "cling" on the lining of the pocket, with the least possible bulk. Scientifically correct. Made from soft yielding rubber, treated by secret process to prevent it from tarnishing gold or filled cases. No hooks, fastenings or other annoyances. Fits the rim under tension, sealing the joints of the case. Excludes dirt and moisture. Foils pickpockets. Saves hard knocks. The best preventative against dropping watch out of pocket when worn with a fob chain.

Made for 18, 16, 12 and 6 size open face watches.

Price per dozen, \$2.00

Spectacle and Eyeglass Strap Plier No. 105

Price, each, \$1.25

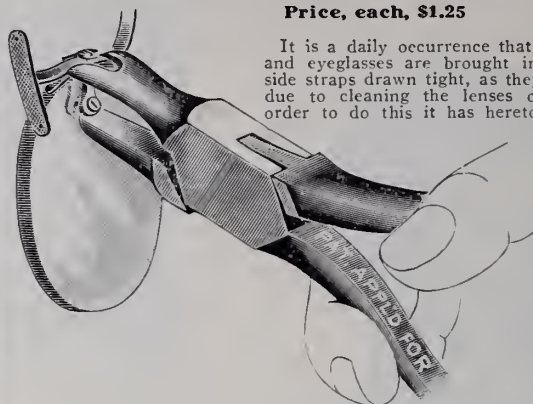

It is a daily occurrence that frameless spectacles and eyeglasses are brought in to have the small side straps drawn tight, as they have become loose, due to cleaning the lenses or other causes. In order to do this it has heretofore been necessary to remove the lenses from the mountings, and as all know, this very often results in breaking or chipping the lenses.

By the means of this plier this can be avoided and the work quickly done.

All that is required is to loosen the screw two or three turns, clamp the frame as shown in the il-

lustration, and bend the straps to the lenses. Retighten the screw, and the work is done.

DO NOT NEGLECT to loosen the screw, as otherwise a good job cannot be done, and the lenses are likely to be broken.

Made of best quality Swedish steel, nickel-plated.



Barrel Cover Plier No. 54

The jaws of this Plier are provided with two circular disks of German silver; both of which are slotted or cut out to admit the longest barrel arbor made. The risk of bruising or scratching the barrel cover is eliminated by the use of this plier. The jaws being parallel, the pressure on the cover is even and full control over the work is possible.

Price, each, \$1.25

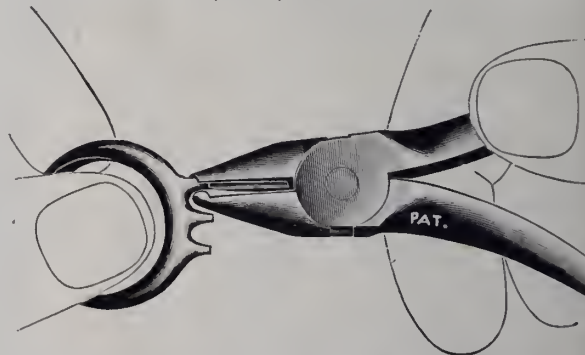

Claw Stretching and Repairing Plier No. 95

This Plier should find ready favor with all jewelers, considering only the saving of time when repairing a broken or worn setting.

Made of best Swedish steel finely nickel-plated. Each, \$1.25

DIRECTIONS:

For repairing worn settings, place slotted jaw on the outer side of the setting and the ball-tipped one on the inner side, pulling from or pushing against the setting, as occasion may require, all the while pressing the handles of the plier firmly together.

With little practice, any jeweler can easily repair a worn-out Tiffany or skeleton setting, or draw out a broken claw as good as new, in less than five minutes.

Unequaled for shaping ordinary settings for Moonballs, Whole Pearls, or any round stone.

FOR SALE BY ALL JOBBERS IN THE UNITED STATES AND CANADA

HAMMEL, RIGLANDER & CO. 47-49 Malden Lane New York

THE

JEWELERS' CIRCULAR

WITH WHICH ARE CONSOLIDATED

THE HOROLOGICAL REVIEW,

THE JEWELERS' WEEKLY,

THE JEWELERS REVIEW

Copyright 1908 by
The Jewelers' Circular
Publishing Company.

11 John St., Corner Broadway, New York.

Entered as second-class matter at the New York, N. Y., Post Office.

40th Year.

WEDNESDAY, FEBRUARY 19, 1908.

Vol. LVI. No. 3.



Handsome Silver Punch Set Presented by the City of Paducah, Ky., to the United States Gunboat "Paducah."

(See Text on Page 39.)

ALVIN SILVER

"ORANGE BLOSSOM"



ALVIN

MFG.

CO.



Cold Meat Fork

Sterling
Silver

The true test of a design in table silver is the effect produced when the table is arranged for formal hospitality.

Pieces of the Orange Blossom design, shown above, make a most attractive group.

This design is made in over one hundred different articles, and is especially suited to wedding gifts.

It is made in sterling silver, stamped with the above trade-mark, and can be obtained from any jeweler, in sets or single pieces, to meet the requirements of complete service.

"BRIDAL ROSE"



ALVIN

MFG.

CO.



Cucurbit Server

Sterling
Silver

The true test of a design in table silver is the effect produced when the table is arranged for formal hospitality.

Pieces of the Bridal Rose design, shown above, make a most attractive group.

This design is made in over one hundred different articles, and is especially suited to wedding gifts.

It is made in sterling silver, stamped with the above trade-mark, and can be obtained from any jeweler, in sets or single pieces, to meet the requirements of complete service.

The two most appropriate patterns of Sterling Silver Flat Ware for wedding anniversaries. These patterns are being advertised in the leading magazines to stimulate trade, and so help the retail jewelers.

These magazines will be read in millions of homes all over the United States.

Be prepared to meet the demand. Complete your stock with fancy pieces and cutlery.

ALVIN MFG. CO., Silversmiths, NEW YORK

Fahys

The retail jeweler recommends Fahys Cases, knowing they have obtained their popularity entirely on their merits for sterling worth and intrinsic value, and is protected in his recommendation.

Fahys Cases have withstood all competition for over 50 years; they are cases that will outlive the present generation of jewelers, and be handled with the same satisfaction by their successors.

All of Fahys Cases are made with our patent one-piece pendant, eliminating all solder.

JOSEPH FAHYS & CO.

New York

Chicago

Boston

San Francisco

A FINE LINE *of* DIAMONDS

Diamond Cutters
 Private Lake
 —
 Fine Fishing
 for
 Retail Jewelers

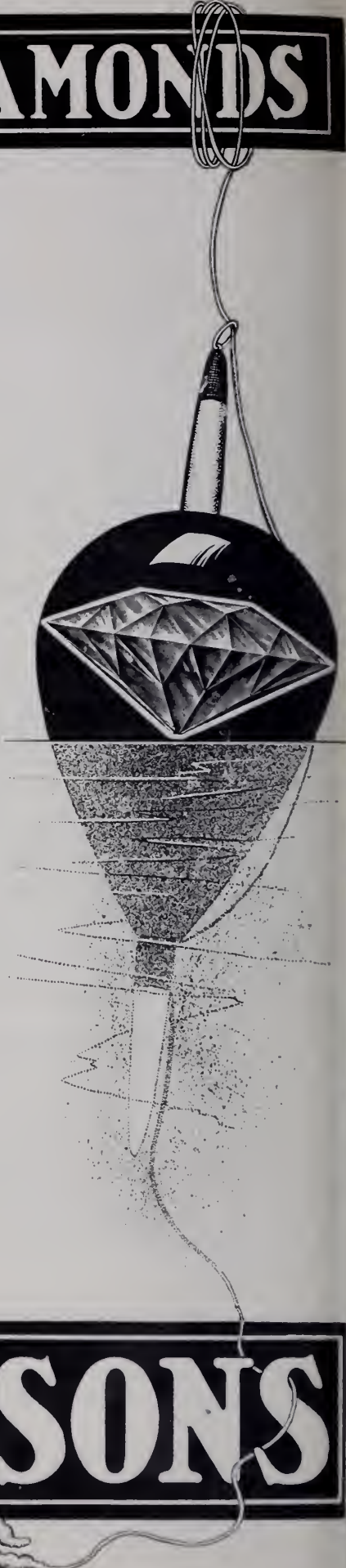
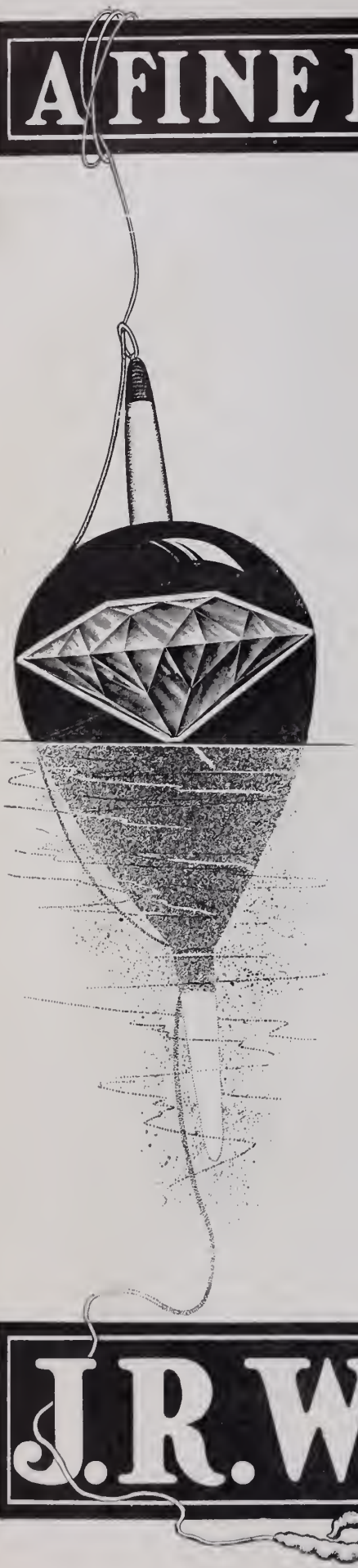

Investigation
 Will Quickly
 Demonstrate
 That Fishing
 in These
 Waters
 Pays Well

J.R. WOOD & SONS

The INVITATION

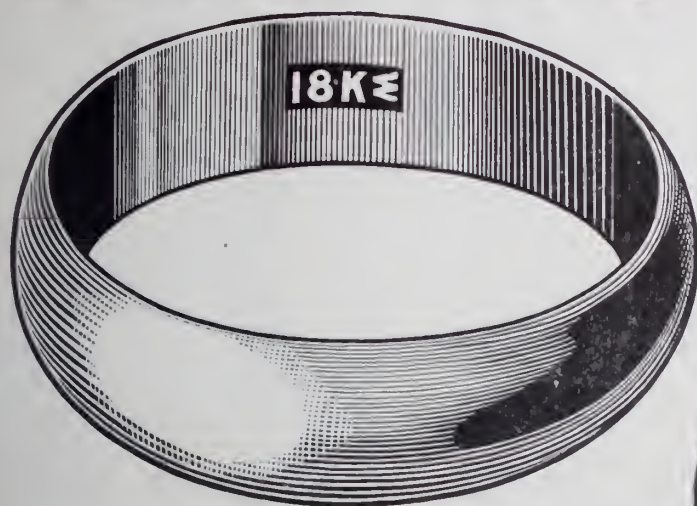

WE INVITE YOU to purchase the best wedding rings made—wedding rings of our manufacture; fully guaranteed as to plump quality and perfect finish.

With all their excellence, our prices are the lowest.

J. R. WOOD & SONS

WEDDING RING MAKERS

2 Maiden Lane, Corner of 170 Broadway

NEW YORK



NEW Goods every week. Our line contains every kind of chain and fob worn by men and women. Our new Hinge Bracelet, the Beulah, in all widths, oval and square, is pronounced the best hinge bracelet on the market. All sizes and styles are made both in side swing and hinge. Our locket fob for ladies is the proper thing.



S. O. BIGNEY & CO.,

NEW YORK OFFICE: 3 MAIDEN LANE.

ATTLEBORO
MASSACHUSETTS

Illustration
about
four-fifths
actual size



WE have one hundred styles of Ring Mesh Bags. Our New Mesh Bag, the Elite, is a beauty, very flexible.

We are headquarters for Mesh Bags this season.

BRISTOL MANUFACTURING CO.,

ATTLEBORO
MASSACHUSETTS



Flat Belcher ring as received with claws badly worn.



How the same ring looks when stone is reset without new claws. Stone is not secure and point is below inside of ring.

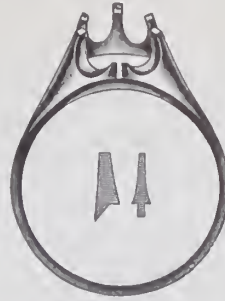

How we splice settings and solder in new claws; seams do not show and rings are as perfect as when originally made.



How ring looks with new claws and stone securely reset. Entire ring is finished like new.

When we tell you that we have received as many as 75 diamond rings in one day for new claws and settings, you will not think us extravagant for using a full page in THE JEWELERS' CIRCULAR to exploit this feature of our business, but will wonder if you are getting your share of claw work.

99 out of every 100 owners of diamond rings willingly pay \$1.50 to \$5 for new claws or settings on their rings, but would not buy new mountings for \$5 to \$25.

It is worth while to familiarize yourself and your employees with this work, as it is one of the important little things that helps to make your business profitable.

WENDELL & COMPANY

The firm that did much to change the repair end of the Retail Jewelry Business from a source of worry and dissatisfaction to one of pleasure and profit.

103-105 William Street
New York

TWO WONDERFUL SHOPS

57 Washington Street
Chicago



Tiffany ring as received with worn off claws. Stone cannot be reset, as it would be too low to look well and the point would come below the inner circle of ring.
(See cut No. 2 of flat belcher.)

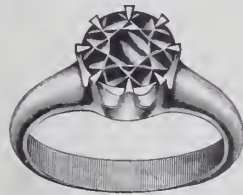

How same ring looks with new claws and stone securely reset. Entire ring is finished like new.



Oval Belcher ring as received with claws badly worn. Stone cannot be reset, as it would be too low to look well and the point would come below the inner circle of ring.
(See cut No. 2 of flat belcher.)

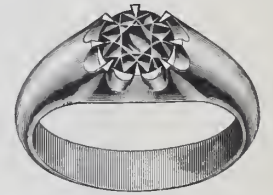

How same ring looks with new claws and stone securely reset. Entire ring is finished like new.

THE PRICES QUOTED ABOVE FOR NEW CLAWS AND SETTINGS ARE SUBJECT TO OUR CATALOGUE DISCOUNT.

WE CAN PUT NEW CLAWS AND SETTINGS ON MOUNTINGS TAKEN IN TRADE AND REFINISH THEM SO THEY WILL BE AS GOOD AS NEW.

WE RETIP CLAWS AND MAKE NEW SETTINGS FOR CLUSTER MOUNTINGS SO THEY ARE AS GOOD AS WHEN ORIGINALLY MADE, AT PRICES THAT MAKE IT ADVANTAGEOUS FOR THE OWNERS TO HAVE THIS WORK DONE.

Carrying no diamonds in stock, entering and tagging each piece of diamond jewelry as received, then giving to each workman but one ring at a time, which is returned before he receives another, prevent any possibility of diamonds being exchanged while in our possession.

The Big Dipper

Will Dip Up Profits For You



THE
BEST IN EVERY
GRADE

CHICAGO
701 Heyworth Bldg.

Ask your Jobber

NEW YORK
Maiden Lane

STARWATCH CASE CO.

LUDINGTON, MICHIGAN

COPYRIGHTED BY T. F. KENNEDY

JUST THE SAME AS EVERLASTING

ALL things must yield to Father Time—nothing is indestructible.
Yet it is quite true that

WADSWORTH PERMANENT

watch cases are "just the same as everlasting," for they will wear so much longer than anybody expects them to that, in the end, they will be carefully laid away to be cherished with the other family heirlooms.

Grace and artistic in design, perfect in workmanship and truly permanent, they represent the maximum of value, durability and satisfaction.

They would cost more if they were solid, but they would be no more attractive, nor would they give better service.

The Wadsworth Watch Case Co.

FACTORY
DAYTON, KY

CHICAGO
COLUMBUS BUILDING

SAN FRANCISCO
717 MARKET STREET

NEW YORK
49 MAIDEN LANE

Any Hour in the day, you can depend upon finding a Dueber case among these late designs, which will please your customer.

(25 yr 14 K.)

Hampden movements, from the dainty "Four Hundred" series for ladies, to the unparalleled 16 size "Wm. McKinley," are cased at the factory.

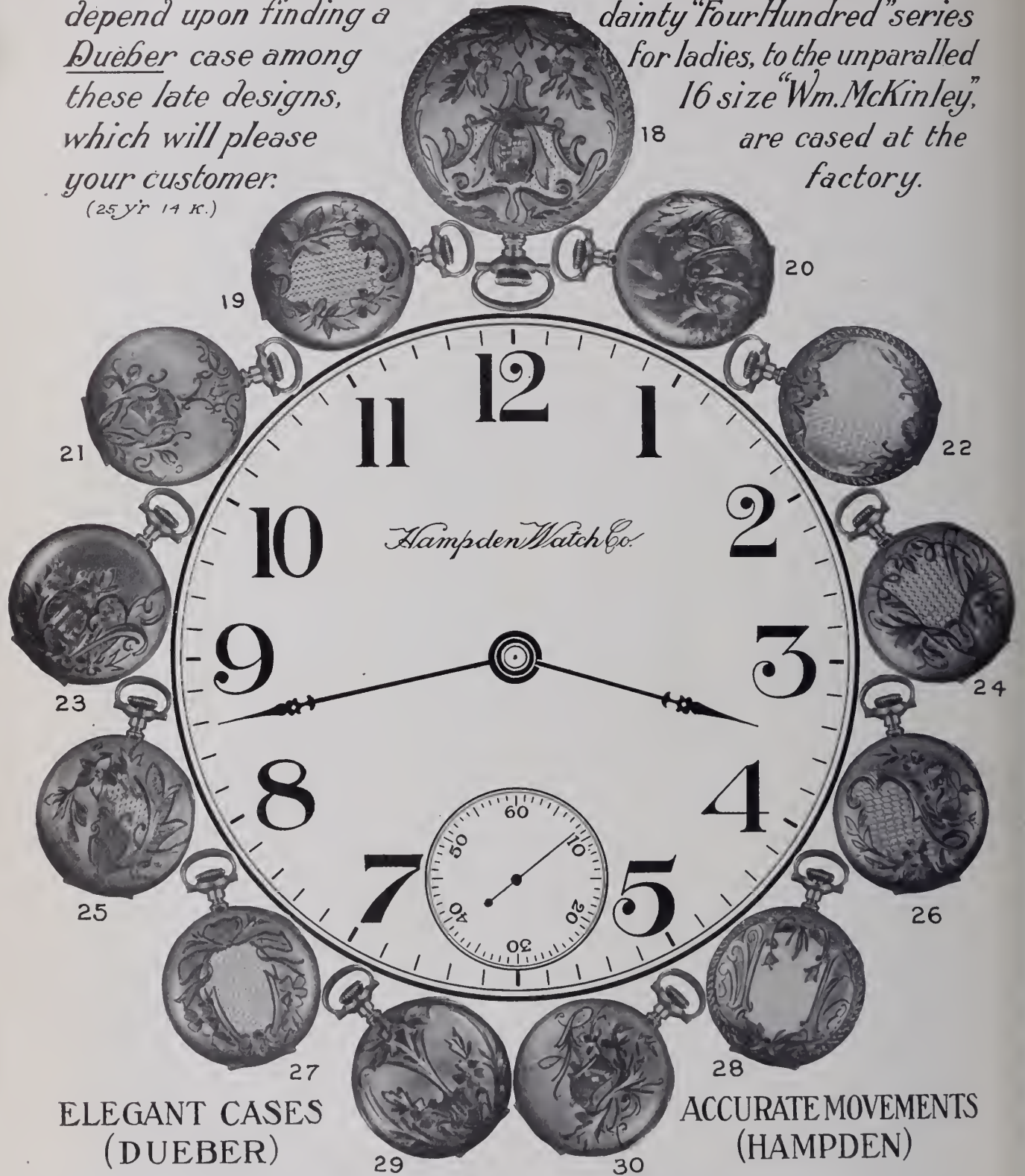

**ELEGANT CASES
(DUEBER)**

**ACCURATE MOVEMENTS
(HAMPDEN)**

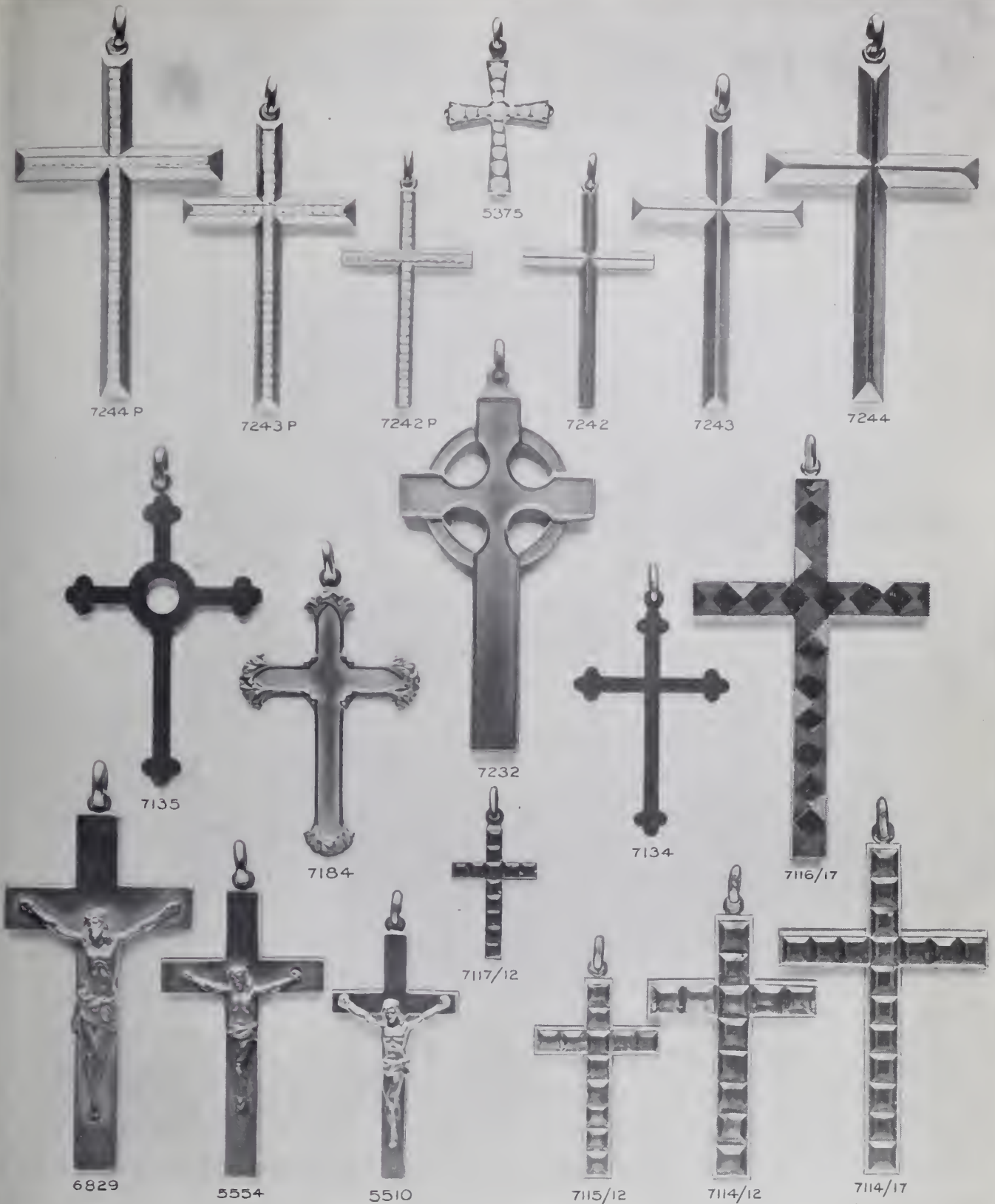

T. W. ADAMS & COMPANY

11 JOHN STREET
NEW YORK

Factory
83 UNION STREET
NEWARK, N. J.

TRADE A 14 K MARK

Manufacturers of 14K. Exclusively

Chicago Office
103 STATE STREET

Illustrations showing full line furnished upon application

Purses for all Purses

WHY LOOK ELSEWHERE TO SUPPLY YOUR STOCK?

From the simple and inexpensive trinket of the unassuming to the most aristocratic and costly conceits. Each grade conceived to meet the taste of some one element of society and all together constituting a line of the greatest possible extent. In the designing, etching and engraving the whims of all the feminine world have been studiously consulted and artistically incorporated with the idea of producing something appealing and consequently easily sold.



The line must recommend itself to the jeweler carrying combination purses and card case, and satchel shaped box purses, for the reason that we can supply these novelties in a practically unlimited variety, from the smallest to the largest made. We have oblong or satchel shaped purses with silk or leather linings; several sizes of vanity boxes, with silver compartments or leather lined, with puff, mirror, pencil tablet and change compartments, and many others, all of sterling silver, that we couldn't begin to enumerate in this space. See the line to understand it.

Representative jewelers are invited to send for a selection. State whether high, medium or low-priced goods are desired.

R. BLACKINTON & CO.

ESTABLISHED 1861. SILVERSMITHS

Factory, North Attleboro, Mass.

3 MAIDEN LANE, NEW YORK

TRADE  MARK

WHITING MFG. COMPANY

Silversmiths



The Outlook

To form a clear and discerning forecast of the probable course of business during the coming year is of vital consequence to every Retail Jeweler.

The timidity bred of an undue pessimism, is as mischievous in its consequences as the rash confidence resulting from an overweening optimism.

The Whiting Company's intimate knowledge of existing conditions, in all sections of the country, is of such a nature as to have encouraged them to make special efforts to meet the already growing demand for goods of acknowledged excellence.

The far-seeing Jeweler, therefore, when replenishing his stock, will give attentive consideration to the established reputation of *Whiting Silverware* for convincing quality and attractive design.

Broadway and Nineteenth Street
New York

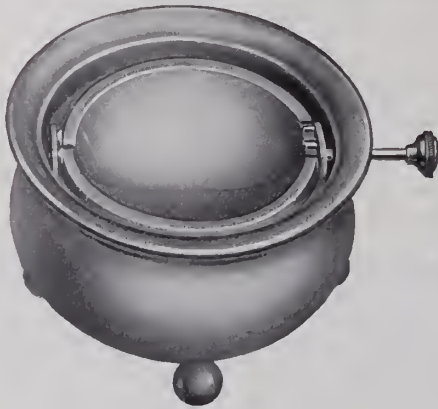

No. 880—Height, 2 $\frac{3}{8}$ inches; diameter, 4 $\frac{1}{8}$ inches

DISTINCTIVENESS

from other styles is characteristic of the Sternau Ash-receivers

They're made in many handsome finishes, such as Old Brass, Velvo, Nickel-plate, Polished Brass and Silver-plate.

The style illustrated here is unique.

It has two shutters forming an upper bowl into which the refuse is thrown.

When handle is turned the ashes or stub of cigar or cigarette fall to bottom of ash receiver.

Thus the refuse can always be kept out of sight. Furthermore, the lighted stub is soon extinguished as the shutters, closed, act as a cover and smother the light.

This is a very novel and convenient feature, because it enables one to do away with a cigarette or cigar, the odor of which may be offensive.

Our Catalogue, No. 21-O, containing many articles appealing to the jewelry trade, will interest you.

S. STERNAU & CO.

New York Showrooms
BROADWAY, COR. PARK PLACE
Opposite Post-office

*Makers of Coffee-machines, Fancy Teakettles,
Chafing-dishes and their Accessories, Smoking Sets,
Candlesticks, Coffee and Tea Pots, etc.*

Office and Factory
195 PLYMOUTH STREET
BROOKLYN, N. Y.



WE show herewith a new style bag—an exceptionally strong, stylish, snappy article.

Our new Spring line is complete—covering the entire range of bags—all shapes, all the different styles of mesh—the largest assortment of frames ever shown. Every piece stamped. W. & D. an absolute guarantee of satisfaction.

Your Jobber has them.

WHITING & DAVIS
PLAINVILLE (Norfolk Co.), MASS.

New York Office, 7 Maiden Lane

O. M. Draper Chains

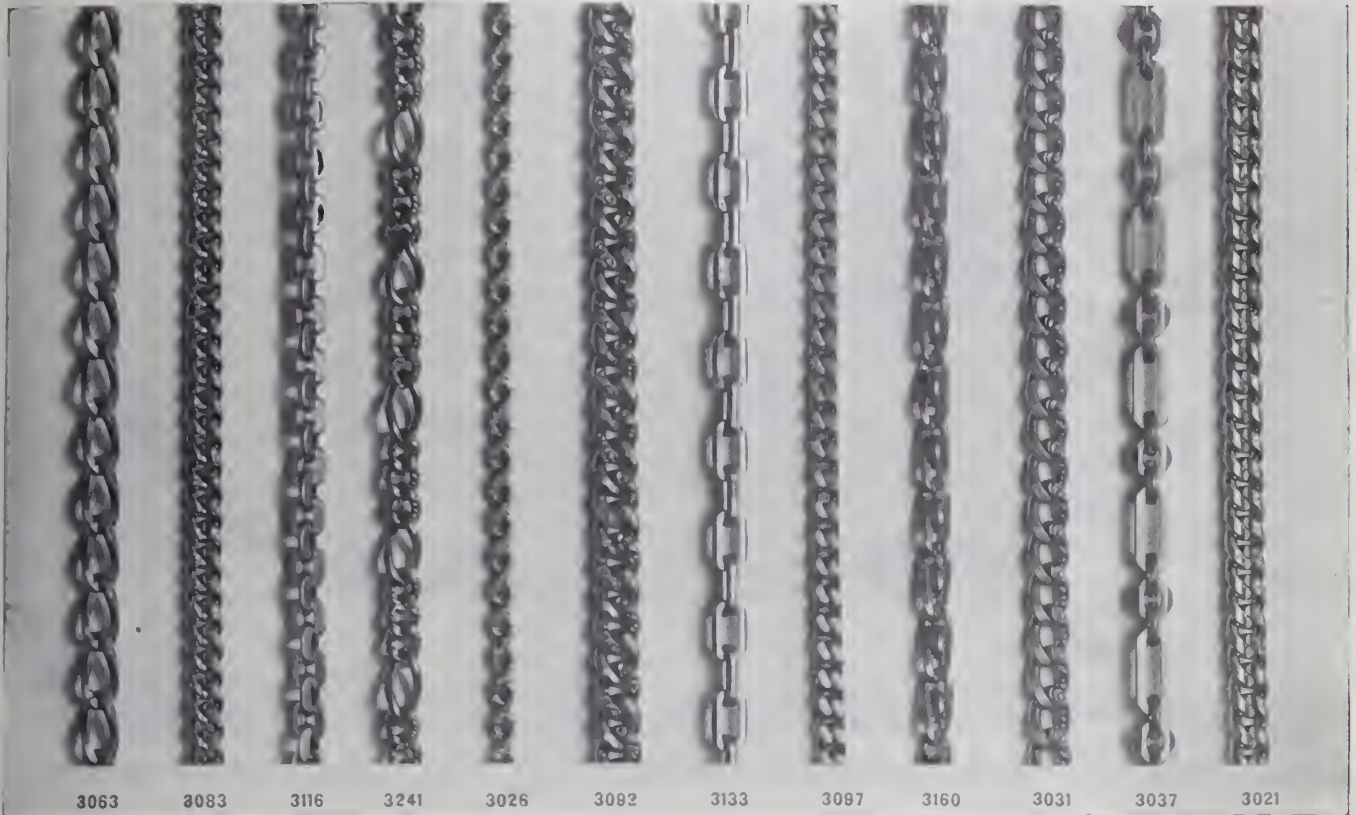

There is no surer method of increasing your sales and consequent profit for the year 1908 than by adding to your stock a thoroughly satisfactory line of chains.

A chain to be satisfactory must not only be guaranteed in every particular, but must be in and of itself a guarantee and give satisfaction to the wearer.

For nearly half a century the **O. M. Draper Chains** have fulfilled all these requirements.

Our Motto: SUPERIOR QUALITY, ARTISTIC DESIGN, UNPARALLELED FINISH.

We show above a few of the large variety of patterns of our one-tenth seamless gold filled line. Ask your jobber for them.

“O. M. D.” Adjustable Bracelet

Our Bracelet is a distinct innovation as far as Extension Bracelets are concerned. All of the defects common to Bracelets of this sort are eliminated in the “O. M. D.” **Adjustable**. No pins or rivets are used in its construction; parts are securely locked together, and no solder is used, which leaves the gold hard and preserves its wearing qualities. Repairs are reduced to a minimum. The Bracelet is made of extra heavy gold filled stock, is reversible, flexible and firm, and is beautiful in design and finish, and a **money maker** for the jobber and his customer who handles it.

Made in all desirable signet and locket tops. Bright, Old English, or Roman finish.

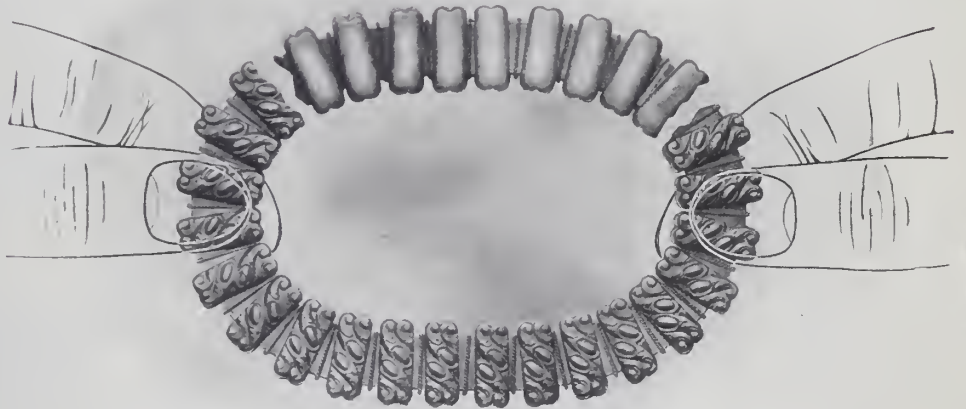

Estate of O. M. DRAPER

North Attleboro, Mass.
Factory

San Francisco, Cal.
503 Chronicle Building

37 Maiden Lane
New York



TRADE \$ MARK

Bead Neck Chains

LINK BUTTONS, GOLD FOBS, RIBBON FOBS,
BRACELETS, GUARD CHAINS, NECK
CHAINS, VEST CHAINS

C. Sydney Smith & Co.

ESTABLISHED 1870

9-11-13 MAIDEN LANE

NEW YORK

FACTORY, PROVIDENCE, R. I.

The "BEST" Safety Fob

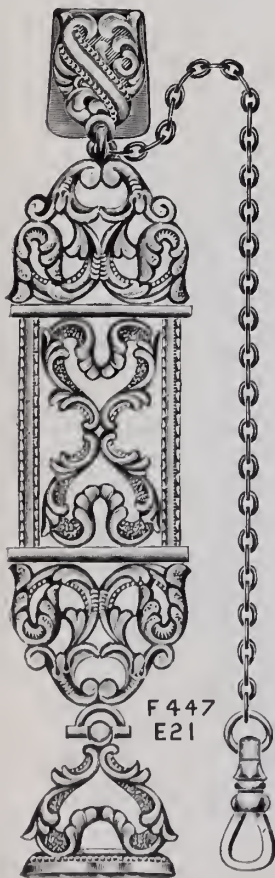

F 447
E 21

Bates & Bacon

ATTLEBORO,
MASS.

High Grade Gold Filled

- Gents Vest
- Dickens
- Safety Fob
- Secret Locket
- Lorgnette
- Eye Glass

CHAINS

Bracelets, Lockets, Chatelaines

NEW YORK:
9 Maiden Lane

CHICAGO:
103 State Street

The "WINNA" Bracelets
Strongest Secret Joint and Catch on the Market

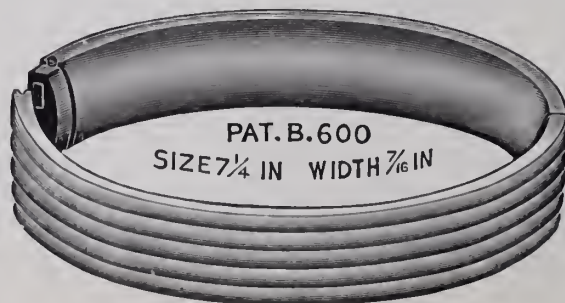

Begin the New Year Right—Complete Your Stock with Right Goods

GOLD RINGS

Gold Scarf Pins

Gold Brooches

A Handsome Line of Seamless Wire GOLD FILLED RINGS

All ready for prompt delivery to the Jobber

OSTBY & BARTON CO.
PROVIDENCE, RHODE ISLAND

New York Office
9-13 MAIDEN LANE

Chicago Office
103 STATE STREET



Lyons Manufacturing Co.

(Successors to Wm. Loeb Co.)

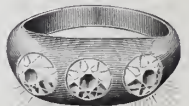
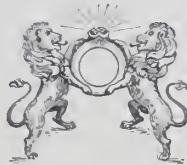

Seamless Gold Shell Rings and Bracelets

Providence, R. I., U. S. A.

NEW YORK
37 Maiden Lane

CHICAGO
1108 Heyworth Building



The Best Selling "Thread" Pattern in the Trade



The SMITH "PILGRIM"

There never has been a more artistic and lasting design than the Smith "Pilgrim." It is characterized by simple elegance, refinement and dignity of design, and grateful absence of over-ornamentation. The Smith "Pilgrim" pattern will remain permanently in demand. Include "Pilgrim" in your stock. It is without question the best selling "thread" pattern in the trade to-day. Made in all the fancy pieces.

FRANK W. SMITH CO. MANUFACTURERS OF STERLING SILVERWARE Gardner, Mass.



TRADE MARK

MR. RETAILER: "Lift the Lid"

just enough to show your customers
a few SOLIDARITY GOLD WATCH
CASES and you'll do business all
right. :: Your jobber can help you.

Solidarity Watch Case Company

Established 1885

54 Maiden Lane, New York

General Selling Agents:

JOHN W. SHERWOOD

:: ::

FRANK E. HARMER

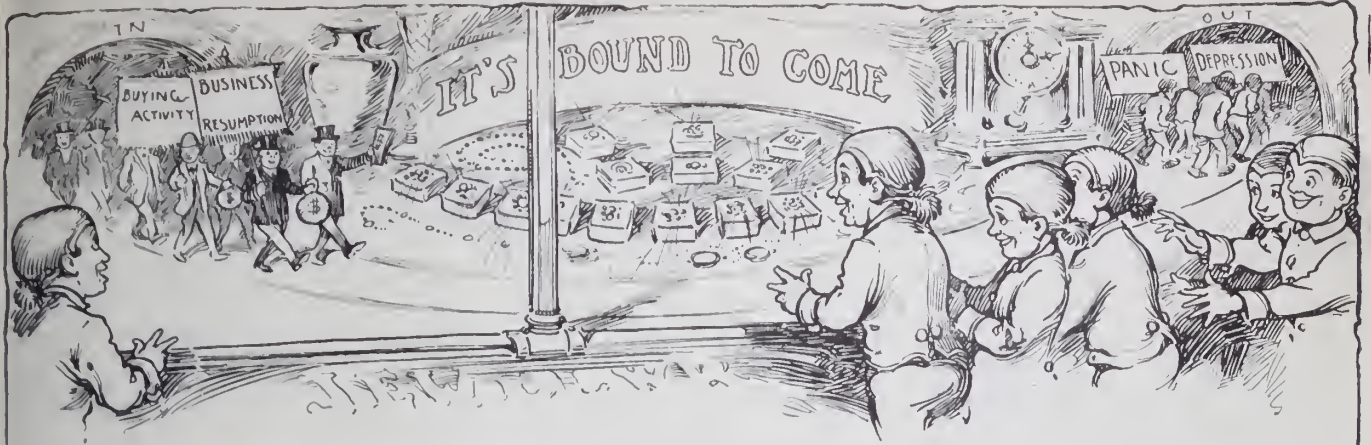

WHILE conditions are gradually becoming normal, yet some stimulus is required by the jeweler to create a demand for goods. This can be most satisfactorily accomplished by displaying a line of jewelry which, by its attractive appearance, excellent finish, and moderate range of price, is bound to interest the average purchaser. Our lines meet these requirements exactly and you are bound to readily dispose of our "Sellers." Our representatives will be pleased to demonstrate this more effectively by showing the lines.

Special orders and jobs always receive particular attention and we will ship anything desired in diamonds, watches  or jewelry. Elk and Fraternal Order of Eagle goods a specialty. The "Rose" our trade-mark is a symbol of quality and excellence.

HENRY FREUND & BRO.,

71 NASSAU STREET, NEW YORK CITY.

**RETURN
OF THE
SASH PINS**



**A
VOGUE
FORESEEN**

ANTICIPATION is a form of enterprise. This house has foreseen the return of the Sash Pins, which have been somewhat over-shadowed by Buckles the past few years—but they are rushing back into favor again. The easy adjustability of Sash Pins renders them eminently practicable, and they impart that graceful dip to the waist which modistes love. Besides rich die effects, fine imitation stones adorn new designs.

AMETHYST—TOPAZ—LAPIS LAZULI

D. Lisner & Co. *Creating Importers of* **Jewelry Novelties**
One-Forty Fifth Avenue, cor. 19th St., NEW YORK

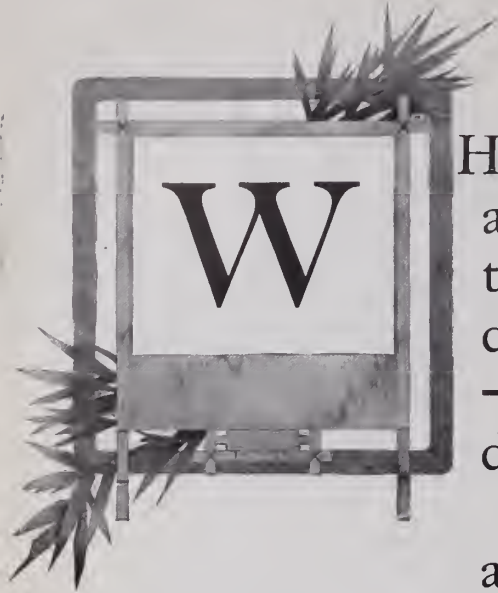

WHEN buying Spring stocks, wide-awake jewelers will be guided by the fact that the coming season's demand will mainly be for *staples*—goods of recognized quality and dependability.

Among this class of goods there are no surer sellers than SIMMONS CHAINS and FOBS.

They are goods that your customers know, and about the reliability of which there is no question. They are the kind that you can show with entire confidence and sell with little effort—without ever a fear that the purchasers will be disappointed.

The Year's Best Bracelet Proposition

From all indications, secret joint and catch bracelets will be first rate sellers this year again, and the acknowledged best bracelet of this type is SIMMONS ARMILLA.

Last year's sales proved it—this year's sales will confirm it.

It will be worth your while to see the 1908 Armilla line and to put in a careful selection from the many handsome patterns and beautiful finishes the jobbers are showing.

R. F. SIMMONS COMPANY

Main Office and Works, ATTLEBORO, MASS.

New York Salesrooms
9-13 Malden Lane

Chicago Salesrooms
42 Madison St., (Heyworth Bldg.)



The KREMENTZ LINE of SERPENT JEWELRY

IN
NECKLACES
AND
BRACELETS

MOUNTED WITH DIAMONDS, SAPPHIRES,
AMETHYST, TOPAZ, TURQUOISE MATRIX, ETC.
Bracelets Are Supplied With Solid 14-Kt. Gold Springs

NECKCHAINS of Any Length Desired



Bracelet, 2098.
Neckchain, 2140.

Necklace, 2122.

Bracelet, 2118.
Neckchain, 2129.

KREMENTZ & CO.

Manufacturers of

Fine Gold and Enamel Diamond Jewelry in 14-Kt. Only

MADE EXCLUSIVELY FOR FINE RETAIL JEWELRY TRADE

BRANCH

San Francisco Office
722 Shreve Bldg.

Factory and Main Office
NEWARK, N. J.

BRANCH

New York Office
1 Maiden Lane

A HUNDRED STYLES IN STUDS



A CENTURY of Studs, a round hundred styles; this cycle of showings affords exceptional range for selection. Studs for dress occasions, studs for ordinary wear, studs for mourning, studs for all occasions. There is no doing things by halves. So complete a line solves all Stud problems.



DURAND & CO.

49-51 FRANKLIN STREET
NEWARK, N. J.



ENOS RICHARDSON & Co.

MANUFACTURERS OF

14-K GOLD JEWELRY



- | | |
|-----------------|------------|
| HANDY PINS | TIE CLASPS |
| SAFETY PINS | VEIL PINS |
| BROOCHES | HAT PINS |
| FLAT LINKS | SCARF PINS |
| DUMB-BELL LINKS | BARRETTES |
| FOBS | BELT PINS |
- 10-K AND 14-K NECK CHAINS AND GUARD CHAINS
PLAIN AND JEWELLED LORNETTE CHAINS

23 MAIDEN LANE, NEW YORK



The R. S. Cigar Cutter

In Sterling Silver, Plain and Engraved; and 14 k. Gold, Plain and Engraved, also Set with Diamonds.

A Novelty

Unlike all other cigar cutters, this one lies flat in the pocket—does not get out of order.

A Good Article



We Push It

Our advertising makes the customer want it; his friend sees it and he wants it. An endless chain of customers.

A Good Seller



Trade supplied by
Enos Richardson & Co.
23 Maiden Lane, New York.

G. R. HOWE
W. T. CARTER
W. T. COUGH

ESTABLISHED 1841 BY A. CARTER

F. R. HORTON
F. W. STANBROUGH
H. L. FARROW

CARTER, HOWE & CO.

MANUFACTURERS OF

GOLD JEWELRY



Bags and Purses in Gold and Silver

9-11-13 Maiden Lane, New York

Factory, Newark, New Jersey

I. N. LEVINSON, President.

ESTABLISHED 1865

H. S. MORRIS, Sec. & Treas.

S. COTTLE COMPANY

Makers of High-Grade Gold and Silver Novelties

MESH BAGS
CARD CASES
PURSES
BUCKLES
VANITY CASES
CHATELAINES

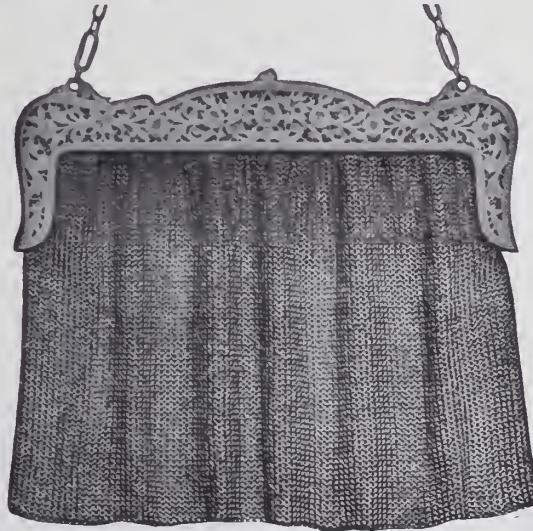

Our new line for Spring is now ready for inspection. Many new and artistic designs are shown. We wish to thank our many patrons for their past favors and hope for a continuance in the future.

PARIS
28 Rue D'Hauteville

31 EAST 17th STREET, NEW YORK.

FRANFURT a/M.
Hanse-Haus, 9 Stifftstrasse

GARREAUD & GRISER
68 & 70 Nassau St., New York
LAPIDARIES. PRECIOUS STONES
GEMS in Unique Cuttings

JACOT MUSIC BOX CO.,
IMPORTERS.

Stella and Ideal Music Boxes.
39 UNION SQUARE, N. Y.

HILL & SCHMIDT

71 Nassau Street

NEW YORK

Makers of Artistic 14 kt. Jewelry

SPECIAL DESIGNS IN

LA VALLIERES and HANDY PINS



NO USE ARGUING

The goods speak for themselves.

Try them, and then compare how they move from the same tray with other 10-k. goods.

This is the best argument.

KELLER JEWELRY MFG. CO.

MANUFACTURERS OF FINE GOLD JEWELRY

Brooches, Link Buttons, Locketts, Scarf Pins, Combs, Fobs, Tie Clasps, Charms, Lorgnette Chains, Neck Chains.

64 Nassau St., NEW YORK

Factory, 251 N. J. R. R. Avenue

NEWARK, N. J.

"THE BRACELET HOUSE"

GOLD BRACELETS of every kind
For WOMAN, MISS OR BABY

KENT & WOODLAND

16 John Street, New York

Factory, Newark, N. J.

San Francisco: Julius A. Young



ACTUAL SIZE.

SEED-PEARL NECKLACES IN ALL SIZES.

OSMERS-DOUGHERTY CO.

MANUFACTURING JEWELERS

291-293 SEVENTH AVE., NEW YORK

Bet. 26th and 27th Sts. Telephone, 918 Madison.

DEALERS IN

BAROQUES, PEARLS and FANCY STONES



DESIGNING AND SPECIAL ORDER WORK

TURQUOISE Matrix - Turquoise

Best the World Produces

WE ARE prepared to furnish to the trade Matrix-Turquoise in all shapes and sizes.

Exquisite Color and Markings

We cut Turquoise to order

Mines at Mojave County, Arizona

THE ARIZONA TURQUOISE MINES CO., Inc.

Cutting Works and Sales Office

171 Broadway, New York

SEND FOR CATALOG

Telephone 5728 Cortlandt



Monograms

INITIALS AND FOBS

Our Specialties

Write for Catalogue Prices and Discounts

CHICAGO ART METAL WORKS

63 Lake Street CHICAGO, ILL.

UNIQUE GEMS

SEMI-PRECIOUS CEYLON, URAL and NATIVE

GEMS My Specialty

Prices the Lowest. Sample Papers sent on Request to Reliable Jewelers and Manufacturers.

Louis J. Deacon, Atlantic City, N. J.

Ludwig Nissen & Co.

182 and 184 BROADWAY
NEW YORK

PEARL
NECKLACES
AND
DIAMOND
COLLARETTES

Mounted Diamond
Jewelry of Every
description :: ::

Largest assortment
of all kinds of very
fine, fancy and rare
gems, including
Pearls, Diamonds,
Emeralds and
Sapphires :: ::

PARTICULARLY
FANCY COLORED
AND FANCY
SHAPED DIAMONDS

Ludwig Nissen & Co.

182 and 184 BROADWAY
NEW YCRK

Links for Summer Shirts

APPROPRIATENESS is a virtue. There are
Links that seem to belong to the Summer
shirt. These Gem Links are an example. They
strike the true note of color. Stones:

AMETHYST, TOPAZ, GARNET
CHINESE JADE, NEW ZEALAND JADE

Scarf Pins to match emphasize the pleasing
harmony. Good selling lines appealing to gentle-
men of taste.

... Scarf Pins to Match ...

Day, Clark & Co.

MAKERS OF 14-KT. JEWELRY
23 MAIDEN LANE
NEW YORK



BUY GOODS WITH A TRADE-MARK



BANGLES
BROOCHES
BANGLE BRACELETS

HANDY PINS
TIE HOLDERS
VEIL PINS

A General Line of Fine Jewelry

BIPPART, GRISCOM & OSBORN

OFFICE AND FACTORY
Newark, N. J.

NEW YORK SALESROOM
1 West 34th St.

Notice

Because

A person happens to dress in black, there is no reason why they should not enjoy wearing the very latest fashions. Consequently we make all the latest fads and fancies in Mourning Jewelry, as well as a complete line of regular goods in Black Enamel.



TRADE-MARK

H. J. Hedges & Co.

Makers of 14 K. Jewelry

14 John Street

New York

SCARF PINS



Jade, Coral, Opal Matrix, Star-Sapphires, and other stones, in 14k. plain edge.

35 Maiden Lane,
New York.

Geo. O. Street & Sons.

Roger Williams Silver Co.,

PROVIDENCE, R. I.

Sterling Only.

RICH DESIGNS :: :: :: Photos. on Application.



THE ARCHIBALD-KLEMENT LINE OF

SILVER DEPOSIT WHISKY BOTTLES

Distinguishable for their dignity of design and excellence of finish. Made in full quart size, four designs—Narrow Strap, Broad Strap, Rye, Thistle. Shield space for monogram, sterling silver corkscrew tops. Highball and whisky glasses to match each design.

No. 58

Full line of the foregoing, and any other desired pieces in the A-K Silver Deposit Ware, sent on approval.

ARCHIBALD - KLEMENT CO.
Sample Rooms: 341-347 Fifth Ave., N. Y.
Factory: NEWARK, N. J.

The Allsopp Rings

The Up-to-Date Line of

Signet and Set Rings

In twenty years we have built up a business second to none in RINGS EXCLUSIVELY

Allsopp

QUALITY,
DESIGN AND
WORKMANSHIP

Appeal to the Most Fastidious.
It Will Pay You to Examine
a Selection Package.



A ★
TRADE-MARK



Allsopp Bros. Allsopp Building, Newark, N. J.

ABEL BROS. & CO.

64-66 JOHN STREET
Corner William Street
ABEL BUILDING
NEW YORK

Branches at LONDON—PARIS—AMSTERDAM—ANTWERP—IDAR—OBERSTEIN

Diamond Mounted Jewelry



Fine Diamond Mountings

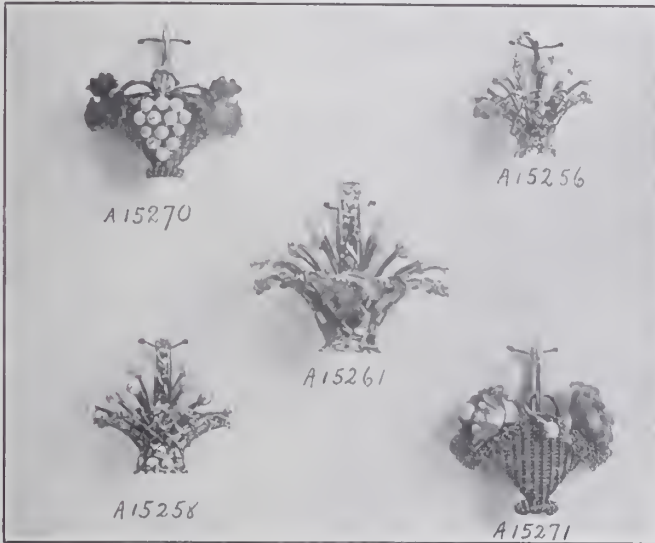

Loose Diamonds, Pearls
Rubies and Sapphires

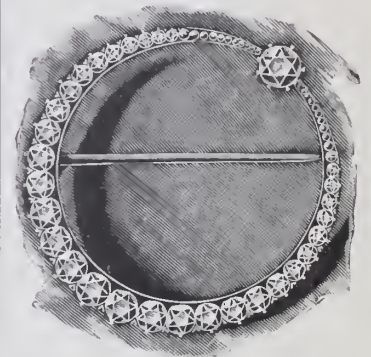

ORIGINAL DESIGNS



SOLID GOLD CHAINS

bearing our trade mark stand for the highest achievement in gold chain manufacture. Plump quality, perfect workmanship, careful finish and attractive designs—all combined—distinguish our product.

WE SELL DIRECT TO YOU

No intermediaries, no corps of salesmen, no unnecessary expenses to add to the price—just the cost of the gold, the cost of making and a modest profit for ourselves enable you to buy the best chains at the lowest price. **SEND FOR CATALOGUE.**

ALOIS KOHN & CO.

16-18 MAIDEN LANE, NEW YORK

Gold Chains of Every Description

The Bowden Rings

ARE COMPLETE IN VARIETY, CORRECT IN
QUALITY AND PERFECT IN FINISH. WE
MAKE EVERY VARIETY OF FINGER RINGS.

J. B. BOWDEN & CO.,

1 Malden Lane.

NEW YORK.

Do not have New Cluster Heads made

We repoint Clusters, Marquise, Princess and other fancy rings; we make them like new at very reasonable prices.

One trial will convince you that we do exactly what we claim. We make a specialty of all kinds of repairing. Write for price list—it will pay you.

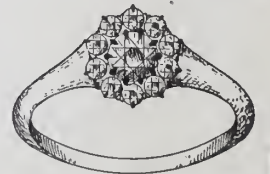
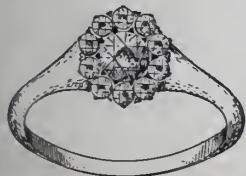

As received from Customer

ARONSON & SPIEGEL, 78 Nassau St., New York

As delivered to Customer

PLATINUM TIPS
EASILY SOLD

ARCH CROWN MTGS.

PLATINUM TIPS
EASILY SET



The gold tips always wear out first on the average mounting. Platinum outwears gold ten to one, so that platinum tips are practically impervious to wear. They blend with the diamond, enhancing its beauty. Platinum Tip Arch Crowns are the ideal gem settings. Your customers will appreciate being shown such a mounting, and are readily induced to buy.

ARCH CROWN MFG. CO. Send for New Price List Sole Makers and Patentees **26 Camp St., Newark, N. J.**

The Comb House

¶ We beg to call your attention to our fine line of new, Exclusive and Artistic Combs, both plain and mounted in Genuine and Imitation Tortoise Shell. ¶ We manufacture Combs exclusively in Genuine and Imitation Shell, both plain and mounted in 14kt., 10kt. Sterling and Gold Filled

SELECTION PACKAGES SENT TO RELIABLE JEWELERS

Wagner Comb Manufacturing Company

41 Union Square HARTFORD BUILDING New York

TRADE **SNOW & WESTCOTT**

21 MAIDEN LANE, NEW YORK

MARK, JAMES P. SNOW CHAS. E. WESTCOTT

Makers of Fine Gold Jewelry

ESTABLISHED 1834

Established 1879

Manufacturer of

LOUIS W. HRABA Fine Leather Goods

29 East 19th St., New York

Exclusively for the Jewelry Trade

Mr. Jeweler:

Do you know that hundreds of your competitors in all parts of the country are making a specialty of Fans? Do you know that even a small line of Fans, properly displayed, will "dress up" the whole appearance of your stock? Of course, the Fans themselves must be suitable for jewelers, and must be bought from one who thoroughly understands the requirements of your trade. There is but one such house in America—

Louis Steiner

ESTABLISHED 1870

FANS
and Novelties for
the Jewelry Trade

**520 & 522 Broadway
New York**



35 MAIDEN LANE

Manager
New York Office
for

MIDDLETOWN SILVER CO.

Silver Plated Hollowware

O. F. EGGINTON CO.

Exquisite Cut Glass

CORNING CUT GLASS CO.

Popular Specialties

ROGERS SILVERWARE

Write for Prices

SPRING TONICS

TONE up your Spring business with some of our INVIGORATORS



14 K., Pearl Set, \$4.50
A Leader in Brooch Values

New Things in Brooches, Links, Scarfs, Fobs, Buckles, Bracelets, Combs, Hat Pins, Veil Pins, Bags, Festoons, Etc.



2 Maiden Lane New York City



FANS AND FRENCH JEWELRY NOVELTIES

THE latest European Novelties in all grades of

FANS

Lace, Painted and Spangled effects, mounted on bone, ebony and mother-of-pearl sticks.

Our goods are made especially for the jewelry trade.

Send for selection, mentioning price.

LEWY & COHEN

Importers of Fans, Jewelry Novelties, Festoons, Buckles, Chains, Necklaces, Collars, and Jet Goods, Etc.
530 Broadway, New York

"If It Is Chopard's Idea, It's Ideal"

ALL QUALITIES

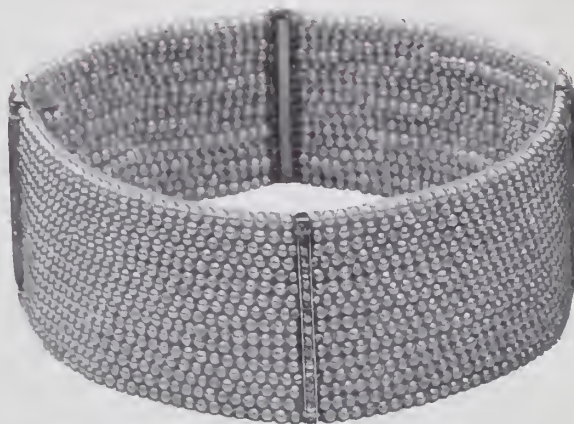

ALL SIZES

OUR PEARLS resemble others only in name. Here the comparison stops, for in Quality, Lustre and Durability they defy competition. COLLARS, NECKLACES, FAN CHAINS in stock.

Remember our Special Department created for you. For Restraining and Mounting Pearls and Pearl Collars AT MODERATE RATES.

CHOPARD FRÈRES

Factory, 35 Rue des Trois Bornes, PARIS, FRANCE

49 Maiden Lane, NEW YORK, N. Y.

VEIL PINS

Among the articles NECESSARY to the well gowned woman are Veil Pins. We are showing them in great variety, both plain and hand engraved, together with our line of "BUSINESS BUILDERS."

Schultz & Co., Inc.

Makers of "Business Builders"

An up-to-date line of 10K. jewelry of all kinds

Factory and Office

91 Oliver St. Newark, N. J.



New York Salesroom

12-14 John St. N. Y. City

After July 1, 1908, this Company will change its name to

Percy M. Layman LAYMAN & STRAUS CO. Sydney C. Straus

The Thimble House.



No. 149.

Thimbles are not a side line with us—They are our main business. We study Thimbles, our designers study thimbles, our workmen study thimbles—The result is the finest and largest line of Thimbles on the Market.



No. 136.

J. H. GALAWAY F. H.

ENGRAVERS

CRESTS, MONOGRAMS and LETTERING

7 Maiden Lane, Rooms 44-45

Established over 35 years

KETCHAM & McDOUGALL,

Manufacturers,

37 @ 39 Maiden Lane, New York.

Send for Catalogue.

Established 1832.

ALSO MAKERS OF THE NEW AUTOMATIC EYE-GLASS HOLDERS.

LOCKETS ONLY

Registered



U. S. Pat. Office



Pat. Applied for
NUMBER
8482

Latest Design Appropriate for Easter

WIGHTMAN & HOUGH CO.

NEW YORK OFFICE
3 Maiden Lane

Main Office and Factory } 7 Beverly St.
PROVIDENCE, R. I.

MANUFACTURER OF HIGH-GRADE DIAMOND MOUNTINGS

Prompt Attention
Given to Special
Order Work :: ::



Estimates and
Designs Submit-
ted :: :: :: ::

Patented October 24, 1906.

DIAMONDS RECUT AND REPAIRED

JULIUS WODISKA, 40 John St., New York

Send for the Latest Styles in MONOGRAMS AND INITIALS

as manufactured by

THOMAS J. DUNN CO.

101 Chambers St., New York
Makers of exclusive styles in

MONOGRAM FOBS

in Gold, Sterling and Rolled Gold Plate.
Our 1908 Ladies' Belt Buckles are most
original and artistic.

Specialties in the Monogram and Initial line.

Send for Illustrated Sheets.



S. F. Myers & Co.

WHOLESALE JEWELERS

47-49 Maiden Lane

New York

There are no gold dollars at half price in our house. Ours are one hundred cents each, and they are worth it.

For the trade only — our
new, big catalogue, with
100,000 items, sent free.

INFORMATION

The right kind of information—the kind that will help you in your daily business work—information that will save you many a dollar is found in our Yearly

GREAT

American Jewelry Catalogue

ASK FOR IT

THE OSKAMP NOLTING CO.

Mammoth Wholesale Jewelers

413-415-417 Elm Street CINCINNATI, OHIO

THE WASHBURN

SECURITY

Automatic Holder
for all sizes of scarf-
pin wire. Guaranteed.

MAGIC NUT

for ear studs, scarf-pins
etc.



EAR WIRES
for unpierced ears.

SAFETY CATCH
For Brooches, etc.
Can be applied to any
work where pin tongue
are used.



Open. Closed. Open. Closed.

Descriptive Circular on Application.

Pearl Drilling and Adjusting a specialty.

Special Order Work and Repairing.

C. IRVING WASHBURN, 12-16 John St., N. Y.

THE CROWN PATENT SAFETY GUARD

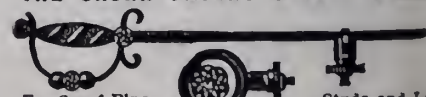

For Scarf Pins
Plugs. The most
adjustable one invented. Price, \$1.50 per doz. For sale
by all wholesale jewelers and material houses. Sample
by mail, 25c.; in 10k. gold, \$1.00; 14k., \$1.25. M. CROWN
Maker and Inventor, 48 and 50 Maiden Lane, N. Y.

Perennially Popular

THE best evidence of the popularity of our various lines is the increasing demand for them and our consequent growth. Our jewelry is unexcelled in every quality that contributes to serviceability and appearance. The designs are artistic enough to court that investigation which results in sales.



Ask to see our line of

**CHAINS
CHAIN PENDANTS
CROSSES
AND BRACELETS**

The
**Kenilworth
Bracelet**

particularly, the strongest
on the market.

**DORAN,
BAGNALL & CO.**

North Attleboro, Mass.

OFFICES

New York: 194 Broadway
Chicago: 42 E. Madison St.
San Francisco: 91 Drumm St.

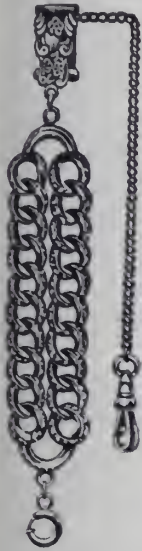

**Electric
Flasher
Watch
Sign**
\$8.50

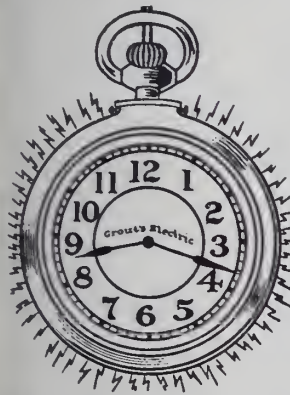

Greatest novelty and window attraction ever made. Heavy oval frosted glass body, 10 inches diameter, gold finished crown and bow, enameled lettered dial. Will hang on any cord or socket. Sold by all jobbers, or

GROUT'S EXCELSIOR SIGN CO., Chicago, Ill.
Send for Catalogue 126 Dearborn St.



Try Wells' Perfect Ring Adjusters

1 doz. asst. sizes 10k gold filled (gold on front twice as thick as on back), \$2.00.
1 doz. asst. sizes solid 10k gold, \$3.75.
1 doz. asst. sizes, metal, 85c. Ask your jobber for them, or I will send, prepaid, at once (only on receipt of price), two samples—one small and one medium large gold filled and one metal adjuster for 50c. Address

CHESTER H. WELLS, Jeweler, Meshoppen, Pa



WE desire to call the trade's attention to our latest creation in Souvenir Spoons for the College Trade—

*"The
Whole
Family"*



These articles have proven ready sellers, so that every jeweler who caters for college trade should not be without them. Write to us for samples, prices and terms.

THE KINNEY CO. Main Office and Factory, 14 Blount St. PROVIDENCE, R. I.

We have the most approved
Reducing Machines

Crees & Court
Die Sinker

21 Eddy St., Providence, R.I.

DIES

FOR

**JEWELRY
SILVERWARE**

Medals
Emblems
Brass Goods

Write us for a
Selection of
DESIGNS

SEND YOUR SWEEPS to the
Cincinnati Gold & Silver Refining Co.

REFINERS, ASSAYERS AND SMELTERS

Office, 523 Elm Street; Works, 2257 Eastern Avenue; CINCINNATI, OHIO



Highest Price Paid for Gold, Silver and Platinum Platinum and Gold Fillings Refined by the Russian Method

P & B BABY PINS

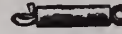

BABY PINS—ALL DESIGNS
SUITABLE FOR BABIES OR GROWN-UPS
We are the Largest Exclusive Makers of 10 K. Jewelry
Ask your jobber for the P. & B. Lines of Cuff Buttons, Crosses, Bead Necks, Tie Clasps,
Brooches, Baby Pins, Scarf Pins, Bracelets, Lockets and Fobs.
NEW YORK OFFICE, - - 65 NASSAU ST.

POTTER & BUFFINTON CO.
PROVIDENCE, R. I.

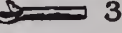
-  1. Snap complete.
-  2. Outside of snap.
-  3. Inside of snap.

The E. P. H. Patent
NON-PULL-OUT
Neck Chain Snap
Is a patented snap that insures the wearer against loss of
CHAIN or CHARM
for it positively will not pull out

Made in 10 and 14 Karat Gold and in Gold Filled.

Can be had of the following Wholesale Selling Agents:

- Messrs. W. Green & Co.,
81 Nassau St., New York
- | | |
|------------------------------|-------------------|
| M. Sickles & Sons, | Philadelphia |
| E. A. Cowan & Co., | Boston |
| E. & J. Swigart, | Cincinnati |
| Swartchild & Co., | Chicago |
| Nordman Brothers, | San Francisco |
| Leonard Krower, | New Orleans |
| A. Walker Co., | Providence, R. I. |
| Bauman-Massa Jewelry Co., | St. Louis |
| H. S. Melskey Co., | Lancaster, Pa. |
| The Edw. Lehman Jewelry Co., | Denver, Col. |

PRICES.

- 14 Karat—Small, \$7 per doz. net
- Large, \$7.50 per doz. net
- 10 Karat—Small, \$6 per doz. net
- Large, \$6.50 per doz. net
- Gold Filled—Small, \$2 per doz. net
- Large, \$2.25 per doz. net

“SECURON”
“Geraldine Farrar” Gold Medal Bracelets



NO 683 72

DEMAND
SECURON
GUARD
HINGE
BRACELETS
FROM
JOBBER

GUARANTEE Pr. St. Co. MARK INSIDE
WITH SLIDING PATENTED WIRE PROTECTOR

PROVIDENCE STOCK CO.

9-11-13 Maiden Lane NEW YORK CITY	100 Stewart Street PROVIDENCE, R. I.	131 Wabash Avenue CHICAGO, ILL.
--------------------------------------	---	------------------------------------

**10K. GOLD
BRACELETS**



New and Original
— Designs in —
BANGLE, JOINT
— AND —
CATCH SIZES

Scarf Pins, Ladies' Rings
Earrings and Handy Pins

In a great variety
of designs

TRADE MARK

THE
Edwin Lowe & Co., Inc.
F. W. BODWELL, Pres. & Gen. Mgr.

116 Chestnut St., PROVIDENCE, R. I.
New York Representative: Western Representative:
E. T. Wilson, 180 Bway. S. H. Brower

1908 The Year for Coral

Largest Importers of Coral Cameos,
Pears, Beads, Etc., Shell Cameos.

Inquiries Solicited from
Manufacturers of Jewelry.

Jade, Amazonite, Lapis, Coral, Topaz,
Amethyst, Aventurine, Our Specialty.

VAN DUSEN & STOKES CO.
1123 Chestnut Street
PHILADELPHIA, PA.

CRUCIBLES.

Jewelers' Supplies,
Etc.

Established 1850.
J. & H. BERGE,
95 John Street,
NEW YORK.

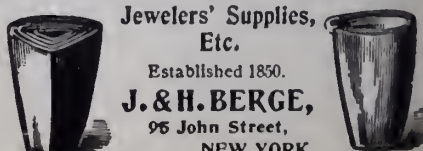

Orders Prove Our Goods Sell

We make for the Jobbing Trade the following lines of Solid Gold Jewelry:

Rings, Scarf Pins, Studs, Brooches, Charms, Baby Pins, Handy Pins, Chain Sets, Link Buttons, Hair Barrettes, Crosses, Ear Screws, Pierceless Drops, Cameos in all styles, etc.

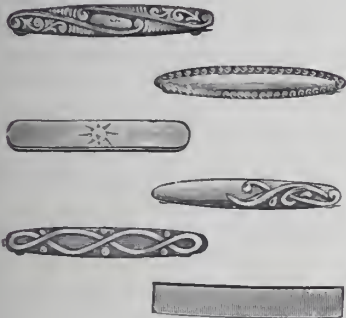

Insist upon seeing the designs of Gold Jewelry made by the

E. L. Spencer Company

95 CHESTNUT STREET
PROVIDENCE, R. I.

NEW YORK OFFICE
9-11-13 MAIDEN LANE

(SAMPLES ONLY)

While your business is somewhat dull you will find it to your advantage to look up the local order for

CLASS PINS

Write us for Catalogue J 30, and Samples

THE CHAS. M. ROBBINS CO.

MANUFACTURING JEWELERS AND ENAMELERS
ATTLEBORO, MASSACHUSETTS

SHUROLDA

Automatic Scarf Pin Protector

14 Kt. Gold Plate

Price 50 Cents

The Stronger the Pull the Firmer It Holds

Pat. Mar. 12, 1907. No. 847,164. Samples and Prices on Application

FOR SALE BY JOBBERS OR DIRECT BY
STERN & CORN, 71-73 Nassau St., NEW YORK

CHARLES M. PRIOR, Designer

We have ready many new designs. Call or write. Etching is more popular than ever and we do it in the finest style.

24-26 East 21st St., NEW YORK
Phone 1639 Gramercy

"VERIBEST" LOCKETS



"Good As Gold"

BE RECEPTIVE TO NEW IDEAS

"Heaven pity the man who won't be shown." If all of the good ideas that have been pigeon-holed and waste-basketed had been considered and utilized, the world would be richer and wiser.

LOOK FOR OUR LINE OF
LEDERERMAK LOCKETS

A LIFETIME SATISFACTION GUARANTEED

Exclusively Sold by **VERIBEST** Jobbers Everywhere

Manufactured by

Established 1870

S. & B. L. ★ CO.

Famous 1908

9-11-13 Maiden Lane, New York City 100 Stewart St., Providence, R. I. 131 Wabash Ave., Chicago, Ill.

EVERYTHING IN LOCKETS AND CHAINS.

THE BASSETT JEWELRY CO.,

PROVIDENCE, R. I.

WM. SMITH & CO.

OFFICE:

Established 1854.

MANUFACTORY:

9-13 Maiden Lane, New York

61 Peck St., Providence, R. I.

Manufacturers of GOLD AND SILVER CHAINS
GOLD, SILVER AND PLATED CHAIN TRIMMINGS

Also GOLD AND SILVER
KEY CHAINS AND
BRACELETS

Trade-Mark.



Trade-Mark.



COLMONT OPERA and FIELD GLASSES

have been recognized by Opticians who really wanted a good article without paying too high a price.

With Colmont Glasses
You Have a Guarantee

The name STANDS for honesty and uniformity of construction, fairness of price.

For your own advantage, investigate the "COLMONT" line at your jobber's.

SUSSFELD, LORSCH & CO.

Importers

NEW YORK

PARIS

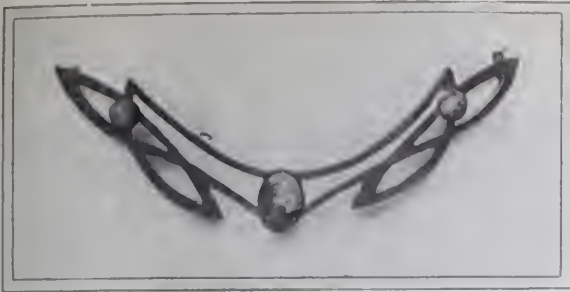

Women of fashion at present are wearing ornaments for the hair more than ever. We anticipated such a demand for these goods and have on hand a large assortment of Rhinestone, Coral and Jet

BARRETTES

from which to select. We also have a magnificent line of Coral Hat Pins, embodying many catchy designs, exclusive carvings and filigree effects, ranging in price from \$4.00 to \$15.00 per dozen.

SELECTION PACKAGES SENT UPON REQUEST

M. GUGENHEIM, Importer of

Brooches, Festoon Chains, Combs, Hat Pins, Collars, Jet Goods, Mesh Bags, in German Silver, Gilt Metal and Sterling

NEW YORK OFFICE: 33 Union Square, Decker Building

PARIS: 32 Faubourg Poissoniere

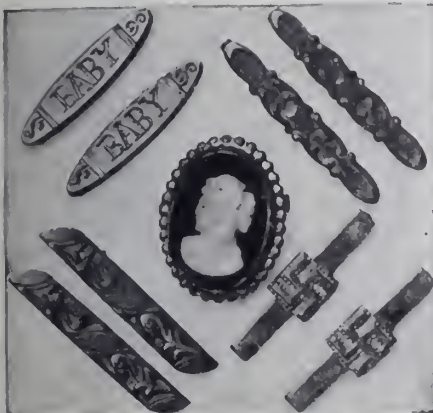

Veil, Cuff and Baby Pins

An immense line. Many new designs supplementing our staple patterns—all of acknowledged beauty, and easily sold.

Cameos A revival of an old-style decoration too good to remain in oblivion.

Shell, Coral and others, mounted as Brooches, Stick Pins, etc.

Swastika Buckles Bracelets Buttons Charms Brooches Barrettes Combs, Hat Pins, Scarf Pins, Leather Trimmings



MILLER, FULLER & WHITING CO.

Manufacturing Jewelers

New York Office, 9-11 Maiden Lane NORTH ATTLEBORO, MASS.

WE SELL TO THE JOBBING TRADE ONLY

URICH PERFECT FITTING Case Screw Washer

Easily adjusted and holds the movement securely even when case shoulder is worn away.
Prices: Gross, \$1.50; Package, 4 doz. assorted, 50c; single doz., 15c.

For sale at all material houses or direct
S. URICH, P. O. Box 1942, New York City

C. VAN SCHOOR

MANUFACTURING JEWELER AND REPAIRER
Best Workmanship. Lowest Prices. Jewelry Findings and Supplies. Importer of Jobbing Stones. Our findings are made of first quality, seamless stock, in all grades, direct from manufacturer to retailer. Our terms are cash. Give us a trial on repair work or send for booklet. Mail orders and repair work filled same day as received.
2041 W. 45th St., Cleveland, Ohio

The "SECURITY" Necklace Clasp

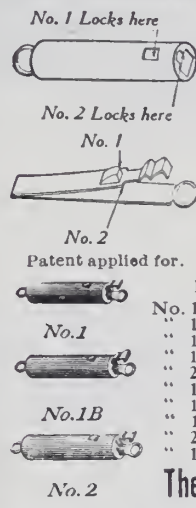

HEAR IT SNAP
Absolutely Secure and Simple. Cannot Pull Out
LOCKS IN TWO PLACES
Making it Doubly Secure
The Only Perfect Clasp

Ask Your Jobber or Write.

PRICES TO THE TRADE:

No. 1.	10-Karat,	- - -	\$6.00 doz.
" 1-B.	10 "	- - -	7.00 "
" 1.	14 "	- - -	7.00 "
" 1-B.	14 "	- - -	9.00 "
" 2.	10 "	- - -	9.00 "
" 1.	Platinum,	- - -	18.00 "
" 1.	Gold Filled,	- - -	2.00 "
" 1-B.	" "	- - -	2.25 "
" 2	" "	- - -	2.50 "
" 1.	Sterling Silver,	- - -	2.00 "

The Hoffman Novelty Co.,

"CLINCH"

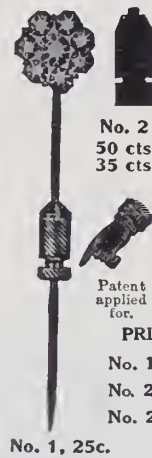

Safety Catch for Scarf Pins

Does not mar the pin. Nothing to get out of order. Simple and neat.

One turn to the right grips like a vise.

..FITS ANY SIZE PIN..

Patent applied for.

PRICES TO THE TRADE

No. 1	Gold Plated	\$1.50 doz.
No. 2	Roman Gold	2.00 doz.
No. 2	14k G'ld Pl'te	2.25 doz.

No. 1, 25c.

Makers, 79-85 No. Pearl St., ALBANY, N. Y.



CAMEOS

Stone, Shell, Coral and Lava. Rolled Gold Plate Mountings

SELECTIONS SENT TO RELIABLE JOBBERS

Maintien Brothers & Elliot
North Attleboro, Mass.

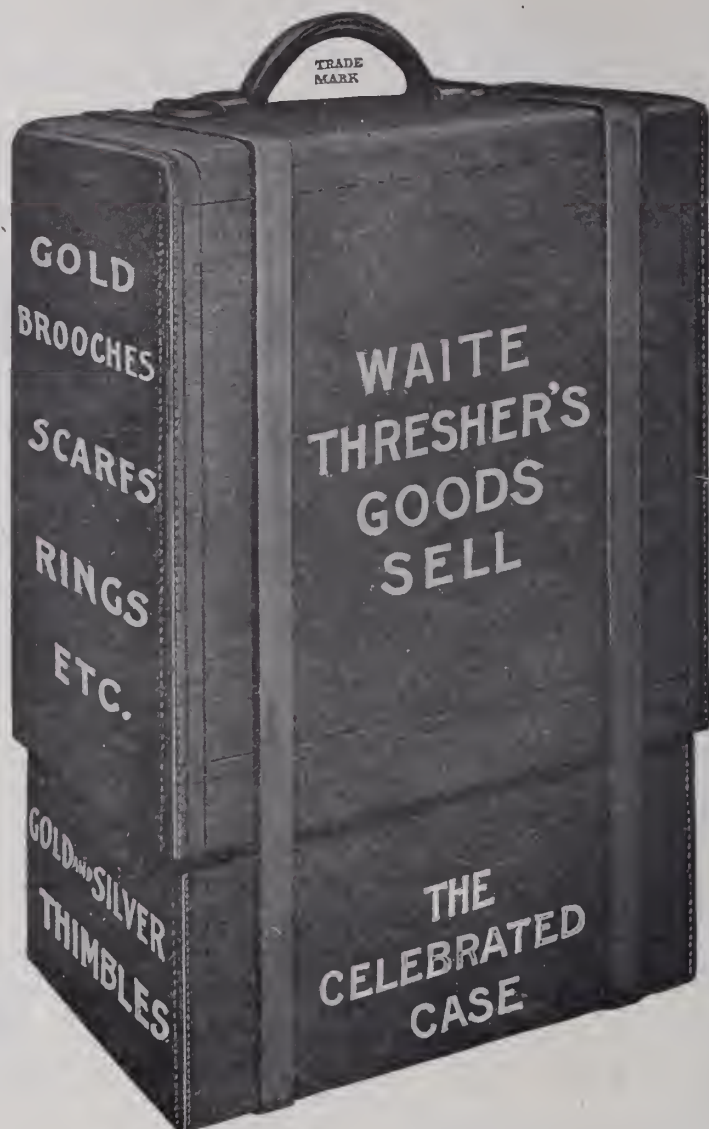

H. J. HOOPER

New York's Leading
Jewelry Auctioneer

Recognized by the Wholesale Houses
the Press and his Patrons

WRITE

him for testimonials that cannot be
equaled by any auctioneer in New York.

Correspondence is strictly between
the principals. Your confidence has
every honorable consideration.

**37 MAIDEN LANE,
NEW YORK CITY.**

An Indispensable Book

for Manufacturers, Jobbers
and Retailers alike is

TRADE-MARKS

of the Jewelry and
Kindred Trades

Price, \$3.00

The Jewelers' Circular Pub. Co.
11 John St., cor. Broadway, New York



The Gillette Safety Razor Set consists of a triple silver-plated holder and twelve double edged, thin, flexible, wafer-like blades (24 keen edges), packed in a velvet lined leather case. Price, \$5.00. Also made in Combination Sets in a variety of styles with toilet accessories retailing from \$6.50 to \$50.00 each.

Would You Have the Coming Year Bring You Increased Patronage, Profit and Prosperity?

Do you realize that nearly every hour in the day some man is converted to the easier, quicker and more economical way of shaving himself with the

Gillette Safety Razor?

Our persistent and vigorous advertising in the leading publications of this country discloses — *and will continue to disclose* — beyond all question of doubt, the superiority of the "Gillette." It advocates the advantages of self-shaving and guides the man to your store with a five dollar bill to exchange for the best shaving device in this world.

You can readily see the wisdom of having the "Gillette" ready when he calls. The Standard Gillette Set retails at \$5.00 everywhere. Combination Sets from \$6.50 to \$50.00. Keep a good supply in stock. Write to-day for valuable selling information and prices.

GILLETTE SALES CO., 904 Times Bldg., New York City



Locket 2985—Old English



Bracelet with Joint
915—O. E., Engraved, Stones set as ordered, 2 3/4"
916— " " " " " 2 1/2"
917— " " " " " 2 1/4"

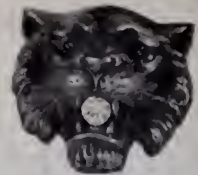

3863—Rose, Red Eyes, White Mouth
3862—Rose, no stone,



3899—Rose, Red Eyes, White Mouth
3898—No stone



3842 Rose, set as ordered
3900 O. E. Set as ordered

Do You Realize

that Spring is near at hand and with it the certain demand for Good Selling Jewelry?

We offer this Season an exceptional line of Fine Gold Filled Goods, among which are Neck Chains and Pendants, Locket and Charms, Link Buttons and Bracelets, as well as Brooch, Veil, Scarf and Hat Pins.

Each design is skilfully executed and beautifully finished.

Our Sterling Silver Ware includes many new styles in Toilet and Manicure Goods, Vases, Candlesticks and Novelties.

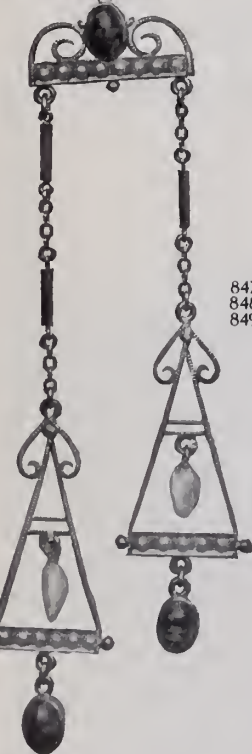

Neck Chain 294—16" long
Old English Chain
Roman Scrolls
Baroque Pearls and Japanese Jades



Hat Pin
847—Rom. Red Enam.
848— " Blue "
849— " Green "



Belt Buckle
3542—Rose, set as ordered
3543—Green, " "
3544—Sterling Grey, set as ordered



851—Rose, Real Malachite Stone
852—Green, Real Malachite Stone



844—Rose or Green Stones set as ordered

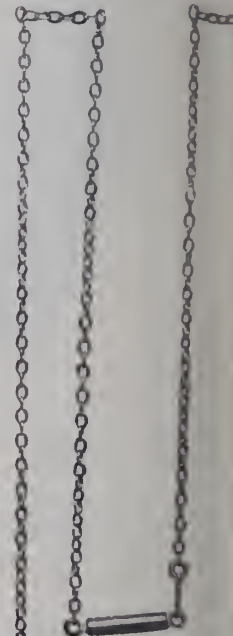

No. 298—16" Neck Chain
Roman Scrolls
Jap. Jade Stones, 3 Real C. Pendants



2978—Roman and Green Pearls and Brilliant
2977 No stone



Baby Pins
3869—Roman
3870—Old English
3871—Pearl Set, Roman
3872—Old English, Pearl Set



3005—Rose, no stone
3007— " Brilliant

Theodore W. Foster & Bro. Co.

Manufacturing Jewelers and Silversmiths

100 RICHMOND ST., PROVIDENCE, R. I.

NEW YORK 13 Maiden Lane

CHICAGO: Heyworth Bldg.

CANADA: Kingston, Ontario

THE JEWELERS' CIRCULAR

WITH WHICH ARE CONSOLIDATED
THE HOROLOGICAL REVIEW
THE JEWELERS' WEEKLY **THE JEWELERS' REVIEW**

OL. LVI. WEDNESDAY, FEBRUARY 19, 1908. No. 3.

ELSIE BEE'S FASHIONS.

NOVELTIES NOTED IN A LADY'S RAMBLES AMONG THE JEWELERS.

WATCH necklaces are still in favor. Either studded with stones or formed simply of engraved or enameled links, their demand is still sustained.

Again the half-pearl is profusely used in brooches of various designs. Bowknots, quite large, form a popular design, the center being studded with a sapphire, or the ribbon ends suspending a baroque pearl. The smaller brooches especially the designs follow those of the diamond brooches.

The two-pocket vest chain for men's evening wear is now being introduced. It is a delicate, simple affair, studded with pearls or diamonds, and it is the proper thing to wear the watch chain on one end and on the other a small match box (for wax taper matches), the decoration of which corresponds with that of the chain.

As a decoration for combs, half-pearls lend themselves most gracefully. With a solid band of shell at the top, an inch or more in depth, a simple row of half-pearls slightly curved or in scroll effect is most charming. One design of note consists of a dainty festoon of flowers caught in the middle and at either end as if suspended from a simple gold ornamentation on the top.

The variety in veil pins is legion. The polished gold with faceted surfaces, the perle effect, the engine-turned in a sort of wave pattern, and the half-pearl ornamentation are among the most exclusive styles. Many of them are now slightly curved to conform somewhat to the shape of the head. The advantage of this shape is evidence both for convenience and appearance.

There is a tendency toward a higher comb with longer teeth. This change in shape is hardly perceptible and may arise from the fact that little toques made of fur or other material are gaining ground. The comb thus projects above the hat and helps to hold it in place. There is also a sign of a growing simplicity in designs. Combs have become so ornate, especially the cheaper imitations, that there is bound to be a reversion sooner or later to the plain, simple styles.

Half-pearl work seems to be coming to the fore again. A short time ago there was a falling off in this treatment, owing to the increase in the price of pearls. But now, for the very same reason, there is an attempt to re-introduce half-pearls, since their high price spells exclusiveness. It is simply

a case of distinction. When an article becomes common because of inexpense, and the domestic adopts it, the mistress at once discards it; but when the price prohibits the maid from purchasing it, the value of the article assumes new proportions to the woman of fashion.

The steady sale of mesh bags has inspired the manufacturer to invent many new attractive designs. There is one in herringbone effect, one of stripes and one of plaids, with still another in imitation of cloth or tapestry, ingeniously made by reversing the mesh; that is, by making it up crossways instead of up and down. They are still shirred and a trifle deeper than formerly. There is an endless variety in the designs of mountings, the bar being either narrow or wide, simply or elaborately engraved, studded with stones or pierced and plain.

ELSIE BEE.

Handsome Punch Set for United States Gunboat "Paducah."

THE punch bowl set, as shown in detail in the illustration on the front cover of this issue, is for the United States gunboat *Paducah*. The set consists of a punch bowl and tray and 24 cups, together with a ladle.

The bowl is 75 inches in circumference, 14 inches in height, and is decorated in repoussé work with conventional designs suggesting nautical subjects, and in addition has several panels containing etched scenes, photographs and seals. On one panel is the etched photograph of Miss Yeiser, sponsor for the gunboat, while others show the City Hall, the Paducah post-office, Paducah wharf, a freight steamboat and a lumber scene, together with the "Pride of Kentucky" (a medallion of a horse), at the center of the bowl. Around the base of the bowl is the following inscription: "Presented to the Gunboat *Paducah* by the City of Paducah, Ky." The bowl is very massive, gold lined, and is finished in high relief.

The tray, which has a circumference of 93 inches, is richly etched and contains the seal of Paducah and the seal of the navy. The 24 cups are richly ornamented and most graceful in shape, and are each three and one-half inches high and three inches in diameter. They are ornamented with a seal. The ladle is 17 inches long and the word "Paducah" is etched on the bowl.

The set was made by the Mauser Mfg. Co., Mount Vernon, N. Y., and was supplied by J. L. Wolff, Paducah, Ky.

The vessels of the United States Navy whose presentation services have been illustrated and described in **THE CIRCULAR-WEEKLY**, and the dates of the issues in which these illustrations and descriptions

appeared from time to time, are as follows:

VESSELS.	ISSUE.
<i>Maine</i>	June 3, 1891
<i>Detroit</i>	July 2, 1892
<i>Montgomery</i>	Feb. 15, 1893
<i>Cincinnati</i>	Sept. 26, 1894; April 24, 1895
<i>Minneapolis</i>	May 1, 1895
<i>Brooklyn</i>	Feb. 12, 1896
<i>Nashville</i>	May 13, 1896
<i>Iowa</i>	July 22, 1896
<i>Raleigh</i>	Oct. 7, 1896
<i>Oregon</i>	April 28, 1897
<i>Massachusetts</i>	June 9, 1897
<i>Wilmington</i>	Dec. 1, 1897
<i>New Orleans</i>	June 7, 1899
<i>Kentucky</i>	June 28, 1899
<i>Olympia</i>	July 26, 1899
<i>Indiana</i>	Aug. 30, 1899
<i>Marietta</i>	Sept. 13, 1899
<i>Wisconsin</i>	May 16, 1900
<i>Illinois</i>	May 17, 1901
<i>New York</i>	May 22, 1901
<i>Alabama</i>	Nov. 26, 1902
<i>Albany</i>	Feb. 11, 1903
<i>Denver</i>	March 18, 1903
<i>Pennsylvania</i>	June 24, 1903
<i>South Dakota</i>	April 20, 1904
<i>Tacoma</i>	June 29, 1904
<i>Ohio</i>	Aug. 2, 1905
<i>Nebraska</i>	Aug. 30, 1905
<i>Missouri</i>	Sept. 6, 1905
<i>Kansas</i>	Sept. 13, 1905; June 26, 1907
<i>New Jersey</i>	Oct. 18, 1905
<i>Milwaukee</i>	Oct. 25, 1905
<i>Maryland</i>	Nov. 8, 1905
<i>Charleston</i>	Feb. 14, 1906
<i>Connecticut</i>	March 14, 1906; Nov. 21, 1906
<i>Tennessee</i>	Nov. 7, 1906
<i>Virginia</i>	Nov. 14, 1906
<i>Louisiana</i>	Dec. 19, 1906
<i>Vermont</i>	Jan. 2, 1907
<i>Chattanooga</i>	Feb. 13, 1907
<i>Washington</i>	Feb. 27, 1907
<i>Georgia</i>	June 12, 1907; June 19, 1907
<i>Rhode Island</i>	Sept. 4, 1907
<i>Paducah</i> (punch set)	Feb. 12, 1908

What's In A Name?

"Mrs. Mudgerson seems to be so affected since her husband succeeded in getting money."

"Yes, she does appear to be afflicted a little in that way. I heard her referring to her father, who was a blacksmith, as one 'who used to be able to make such beautiful designs in wrought iron.'"—*Chicago Record Herald*.

J. M. Welch, Bryson City, N. C., contemplating moving his stock into more commodious quarters on Depot St., in the near future.

The Farley Jewelry Co., Lake City, Ia., has rented the Knudson building, at Lohrville, Ia., where a branch store will be conducted in charge of E. J. Bunting.



No. 1598

A New Ring

The above illustration is one from a new line of rings for women in both 10K. and 14K. gold, which we are now adding to our stock.

Our rule is not to make the same patterns in both qualities; therefore the above pattern can be had in 14K. gold only, made with cabochon cut opaque stones in the following colors:

- Lapis Lazuli Dark Blue
- Dark Chinese Jade . . Dark Green
- Amazonite Light Green
- Epidote Olive Green and Red
- Turquoise Matrix, Light Blue and Brown
- Coral Pink

LARTER & SONS

21-23 Maiden Lane, New York, N. Y.

TRADE-MARK



REGISTERED IN U. S. PATENT OFFICE

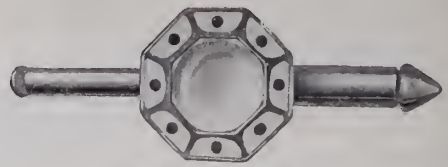

No. 4483

A New Shirt Stud

While we make without contradiction the largest and most varied line of shirt studs in the United States, we are continually increasing it by adding new up-to-date patterns.

The cut above is one from a number of new and original patterns in shirt studs, all having the satisfactory Larter back.

Made in 14K. gold only, with mother-of-pearl center, white enamel and gold border — This combination is not only attractive, but is in absolute good taste for dress occasions.

We also make loose link buttons and Larter vest buttons to match at moderate prices.

LARTER & SONS

21-23 Maiden Lane, New York, N. Y.

TRADE-MARK



REGISTERED IN U. S. PATENT OFFICE

Development in the Art of Jewelry Making

A Paper Read by Mrs. W. S. Hadaway Before the Applied Art Section of the Society of Arts, London

IT is 18 years since an excellent paper by Mr. Giuliano was read here, giving a very comprehensive view of the history of jewelry. I will not go over that ground again, so, with the exception of a few allusions to the past, it is of the jewelry of the present day that I will speak.

It is perhaps strange that the art of the goldsmith and jeweler, which should be an art so romantic and alluring, should have become what it is now—a dull and stereotyped commercial business. Jewelry is produced, like all the other hideous manufactured things, by people who know nothing of art, and whose only care is to turn out as many salable articles as possible. There are a few artists who are doing their best to show that a jewel may still be an object of beauty in which thought and individuality are shown. But, compared with the thousands of slaves engaged in the jewelry trade, they are a mere handful. It is of these artists and their work chiefly that I am going to speak. Of course, public taste controls to a great extent the kind of jewelry that is produced. And the commercial article now holds the field. This is partly, too, because the large firms of manufacturing jewelers understand better how to bring their wares into public notice, and thus hold before the public their standard of taste, which, bad as it is, people know no better than to accept. I would like to explain why the jewelry of commerce cannot possibly be considered as works of art, no matter how elaborate and expensive, and also why the simplest ornament—made even of the less precious metals, and set with the cheapest of stones—may be lovely and satisfying.

If you look over the catalogue of a jeweler's supply shop, you will perceive a very strong reason why trade jewelry is dead so far as any artistic quality is concerned. You will see there the rings, pendants, brooches, and so on, ready-made by the thousand, with holes to receive the stones. And all parts of these—pins, clasps, settings—which should enter into and form part of the design, sold also by the thousand, ready-made. Then, in the factories where these things are turned out, the aim is—not beauty or originality—but the largest return for the money. One man makes only one part, the man who makes each little separate part of a brooch or pendant, cannot make the whole. If he makes clasps, he makes nothing else. If he makes joints, or pins, or settings, or whatever it may be, that one branch is his limit; it is all he can do. It is not his fault that he is narrowed into one groove. It is the fault of the miserable commercial system which inevitably makes profit the first consideration. Then the designs are supplied by men who are not artists, and who are supposed to understand trade requirements.

Is it conceivable that a work of art could result from this means? Is it likely that the workman can take the smallest intelligent interest in what he is producing? The other day, in Charing Cross road, I came across a book labeled "Designs for Jewelry." It looked well used and worn. I thought

"There must be something interesting!" It was evidently a design book of some firm of jewelers. The designs were all nicely and carefully drawn, with a high light on every stone, and each one was, if possible, more stupid than the last. A sapphire surrounded by diamonds, a crescent, a daisy, a star, and so on, through all the glittering list of stupidities. It represented very well the jewelry of most of the shops. It was no worse and no better. All on the same plane, below mediocrity. A shop in Regent St. is advertising its latest novelty. This is called the Diabolo brooch. I leave the rest to your imagination; no doubt large numbers of it will be sold. A Bond St. shop is exhibiting an electric launch in diamonds, surrounded by a life buoy in white enamel with a gold rope. This is an achievement to be ranked with the diamond motor car, after the dogs and birds and horses and foxes, etc., which have been a stand-by for so long. A few firms, I see, are making violent efforts to be artistic. An advertisement which may be seen in a magazine for the current month is amusing. This caution appears: "Avoid machine-made jewelry—it lacks originality." This is accompanied by illustrations of objects, which, I presume, aspire to be what they say are: "Present-day jewels of advanced character." They are more or less unshapely blobs of silver, or perhaps gold, with stones, or enamel here and there. The jewelry trade, having come to this pass, when they attempt to avoid the stereotyped article, they blunder into the would-be artistic, and the result is deformity.

Another firm has evidently secured some designs by artists. I am told that the practice is to buy one example of each kind, which seems to lend itself to the purpose, send these to Germany, where they are cheaply reproduced, and sent back to be sold by the dozen, or hundred, in competition with the work of their originators. This is by way of showing that the path of the artist is not altogether made smooth; he has difficulties of various kinds to meet. Once knowing what happens, I trust he avoids being exploited a second time.

It is interesting to see that, as far back as 1892, when Mr. Tonks read an able paper here upon the "Artistic Treatment of Jewel and Address Caskets," he deplored the unblushing audacity with which much of the work of that day violated every canon of art, and he looked forward hopefully to the future education of workmen and designers, that they might be able to avoid these infirmities. Fifteen years have passed, but most of the caskets, as well as the jewelry for personal adornment, are made in the same way—design and finished work, both turned out in hot haste under the lash of increasing competition. Generally, these caskets are monuments of misdirected ingenuity, the necessity for haste and show has killed the art. Fancy any one nowadays spending 40 years over a piece of metal work, as Ghiberti did on the bronze gates of the Baptistery of St. John!

Edward Spencer, Alexander Fisher, Nel-

son Dawson and Henry Wilson, each have been responsible, of late years, for some very beautiful caskets, designed with thought and art, and executed with skill. But these artists have nothing to do with the miserable system in vogue with the commercial houses. Their work is designed by themselves, and executed in their own workshops under their own eye.

However, it is more of the goldsmiths' and silversmiths' craft as applied to personal jewels that I wish to speak; and especially of what is being done by the small group of workers who may be called the pioneers of the renaissance of English jewelry and silver work, for most of these artists do not confine themselves to jewelry. In most cases they make cups, bowls, caskets and silver dishes of all kinds as well, and many of them also produce larger work in steel, bronze and iron. Ten or 12 years ago, very few artists had turned their attention to jewelry. Mrs. Newman was, of course, the first woman to set up a workshop and salesroom of her own, where the work was carried out by her own workmen from her own designs.

The beginning of the present artistic movement, which is being followed by both men and women, was when Alexander Fisher opened his studio for enameling and metal work. Mr. and Mrs. Nelson Dawson worked in this studio for a time when it was opened, not as pupils, but as co-workers. In those days, it was very difficult to get instruction in the art of enameling. Trade enamellers would not impart what they deemed to be their secrets, and, but for the classes which were held for a time at South Kensington, taught by a Frenchman, there was no instruction to be obtained. Mr. Fisher received his knowledge of the technique of enameling from these classes. Among the first enamellers, too, were Miss Gertrude Smith, now Mrs. Gilbert Bayes, and Miss Nellie Woodward, who now devotes herself to jewelry in general quite as much as to enameling. Miss Eleanor Hallé also was one of the first. To learn the technique of jewelry making was very difficult at that time, too, for trade jewelers would not teach an outsider, and of other jewelers, there were none. However, Miss Woodward and Miss Smith persevered, and by dint of finding out a little here and a little there, gradually gathered together the knowledge necessary for metal work, and the making of jewelry. Among the very first to see the possibilities of artistic jewelry were Mr. and Mrs. Arthur Gaskin. They began by making simple pieces with their own hands. Their work has developed and elaborated, and is known now wherever modern jewelry is known. They are artists first, and jewelers afterwards. This is the case with all successful artist jewelers. Mr. and Mrs. Gaskin taught themselves, too—this is another excellent road to good work. Many of the successful ones have taught themselves, picking up here and there the processes of soldering, and so on. Of course, it is beginning in the right way to apply the art to the craft. The technique of every art or craft is exacting, but the technique can in time be mastered if the essentials are there.

The trade has mastered the technique,

LOUIS KAHN

MOSES KAHN

SAMUEL H. LEVY

L. & M. Kahn & Co.

Importers and Cutters of
DIAMONDS

170 Broadway, cor. Maiden Lane, New York

AMSTERDAM: 2 TULP STRAAT

CUTTING WORKS: 29 GOLD STREET

Arnstein Bros. & Co.

Importers and Cutters of

DIAMONDS

65 Nassau Street

New York

LONDON: Audrey House, Ely Place

AMSTERDAM: 6 Tulp Straat

ALBERT LORSCH.

N. Y. Telephone Call, 2161-2 John.

ALFRED KROWER

ALBERT LORSCH & CO.

LORSCH BUILDING, 37 and 39 MAIDEN LANE, NEW YORK

131 Washington Street, Providence, R. I.

Reconstructed Rubies

IN CABOCHON AND BRILLIANT CUT, ALL SIZES AND SHAPES

vermastered it, one might say, and left the essentials out. Mr. Fisher's jewelry is probably known to every one here. He uses *époussé* with enamel, and little painted enamel plaques mounted in well-designed old or silver settings, sometimes with jewels.

The work of Mr. and Mrs. Nelson Dawson will be known, too, to every one interested in modern jewelry. Mr. Dawson designs large work—iron gates, electric light fittings, and many other things, which are carried out by workmen whom he has trained in his own workshops. Mrs. Dawson does the enamels. Whenever she turns out an enamel of particularly happy color or pattern, her husband designs a setting for it, or she designs the whole jewel herself. Mrs. Dawson tells me that it does not pay very well, as it takes much time and care and money to produce it. They do it really for the love of doing sound and practical work as well as what they consider to be suitable and beautiful. Of course, cheap work cannot be produced in this way, and this is the way in which all artists work.

The chief artistic difficulty all around seems to be to produce good work that will pay, or at least that will provide a living for the workers. There is so much bad and cheap work produced and sold, in competition with the good, and the public often seem to prefer the bad, perhaps because it is cheap, so that there is always before the artist the temptation, and sometimes the necessity, to produce something which will sell quickly.

In 1899, Montague Fordham opened the gallery at 9 Maddox St., in order to bring before the public the best modern handicraft, and encourage a movement which had rather languished since the death of William Morris. Here, standard was put before everything else—even finance. It was from the beginning, the only gallery in London carried on on these lines. Edward Spencer, Henry Wilson, Paul Cooper, Miss May Morris, Benjamin Nelson and W. S. Hadaway were among the first artists to contribute jewelry and metal work, and I think all of them have continued to do so. It has now changed hands, and is known as the "Artificers' Guild." It is run on the same lines, and connected with it are their own workshops at Oil Mill Lane, Hammersmith, under the direction of Edward Spencer. To the workshops, visitors are freely welcomed. The managers are anxious for their clients to go and see the orders being executed, so that they may, in some slight degree, understand the limitations imposed by the material, and the principles which underlie the exercise of their skill, principles which, basing themselves upon utility and expediency, permit just this or that degree of efflorescence, impose this or that degree of restraint. For metals to be tortured into shapes suitable only for some other material, and rendered in naturalistic forms, besides being very unsuitable, offends every rule of taste. Then the extreme finish in fashion with the trade is unpleasant. The makers seem to think by removing all evidences of the workman's touch that much perfection is gained. At the workshops of the Artificers' Guild these are derived from the study of the work of the best periods, not a series of mechanical

designs, but object-lessons in the exercise of beautiful methods of construction, which, together with the spirit in which the old work was made, it is sought to reproduce in the workshops. The jewelry workshop is managed from the technical side by one who is himself a craftsman and an artist, and the terms upon which all boys and girls enter their employment are that the Guild will do their best to equip them with individual independence as master craftsmen in the future. This is how a dignified art is made of what is usually a commercial business.

C. R. Ashbee, a few years ago, removed his workshops to Chipping Campden, Gloucestershire. This interesting social experiment has so far been successful, but, even here, commercialism creeps in. When I undertook to write this paper, I asked Mr. Ashbee about certain jewelry which I had recently seen in his Brook St. shop. He replied that, as I said, a good deal of the jewelry was not up to the standard of their earlier work, and the bulk of it not designed by himself. He said that, in his view, until some proper external standard is set up to check bad workmanship and regulate the shops, it is impossible for good stuff to stand against the competition of the inferior work. This is the rub—the artist has to spend time and care to produce good work, and the ignorant public very likely pass it over for bad and cheap things. There is, however, a class of people of good taste, and they are steadily increasing, who will have nothing to do with shop jewelry, and who know the difference between good jewels and those of inferior workmanship, and it is for these that the artist must work, and among them find his patrons. If people of education and culture in other matters understood anything about ornament, or had taste in the decorative arts, they would shudder at wearing the jewels with which they complacently deck themselves. But the decorative arts are sadly misunderstood by the public at present. I have been in many houses since I came to England 10 years ago, and very few of them that I can recall are really furnished with taste—that is, not filled with overpatterned and unsuitable paper and draperies—not overcrowded with everything, but furnished simply, with not too many pieces of good design carefully sought out, and it requires much searching in London at present to find furniture for a house that a person of taste in such matters would care to live with. If everything were made beautiful and appropriate, instead of hideous and inappropriate, the pleasure of the hunt would be all gone. If the ordinary articles of daily use were made of good patterns and materials, the chase through out-of-the-way places for possible things would be no more.

Then there are the pleasures of bad taste to be considered too. Certain people, far too many of them, do receive pleasure from atrocious things. I know a man who has had all the old oak in his house painted white, with red plush panels! But I am not talking of furniture, I am talking of jewelry. I only want to point out that excellent people, perhaps with kind hearts and high places in their professions, or whatever their walk in life may be, think that little matters, like suitable furniture and

ornaments, are of no moment. And indeed, it would seem they are not, if material progress is the first consideration, for the reign of Victoria, so rich in progress and invention, was one of the periods of the worst taste in artistic matters that the world has ever known, if we except the rococo.

Those who make a specialty of any branch are apt to overrank the importance of it in relation to the many other equally important things, but if an art is to be practised at all, surely it is important to practise it as well as it can be done. Jewelry, of course, ranks among the minor arts, but most people may not realize that to design and execute good jewelry and metal work requires as much talent in its way as to produce any other work of art. Of course, I am speaking only of the best.

Harold Stabler is one of the principal artist-jewelers and metal workers. His church metal work is well known, and he has made some good jewelry. I have seen some charming pieces in the style of the Hungarian work to be found in the Budapest Museum—little five or six-petaled flowers among filagree or leaves. He uses gold and silver together most harmoniously. In one of his necklaces the large central pendant is carved in a wreath of silver leaves and blossoms—among these are settings of gold holding various kinds of stones—within this wreath is suspended a little niche in silver ornamented with niello. In the niche stands a virgin and child in gold *repoussé*. The chain is of silver with gold start at intervals, from which depend eight tiny kneeling angels in silver.

To try to describe a piece of jewelry in words is rather futile, because it is upon qualities which elude verbal description that the success rests, such as the proportion of each part to each other part, the distribution of the stones, the relation of the coloring to the shape of it; in fact, the sizes and shapes and colors of every part of it, which only a drawing or a photograph can make plain. I would like to describe some of the jewels of John Bonner, but I am sure the description could convey no adequate idea of the jewel itself. Some of us will have seen the shrine of the Holy Grail pendant, or the Tristan and Iseult necklace, or some other of his masterpieces of symbolic jewelry. These jewels, designed and wrought with exquisite skill, are among the most lovely of all the modern work.

Henry Wilson, whose practical handbook on jewelry appeared a few years ago, stands at the very head of this movement. Nothing better than his thoughtful and well made jewelry has been done.

Paul Cooper and Bernard Cuznen are both well known artist-jewelers. Time does not allow me to name all those who are working in the right direction. These are a few of the pioneers whose work is best known. A few of the chief women jewelers are Mrs. Traquhair, who is mural painter and embroideress as well; Mrs. Mills, Mrs. Eastlake, Miss Ethel Virtue, Miss Awdry and Miss Steer, of Birmingham; Miss Agnew, Mrs. Roscoe Mullins, Miss Goff, Miss Violet Ramsay, Miss Woodward and Mrs. Gilbert Bayes. Mrs. Partridge is an accomplished enameler, while her hus-

EDUARD VAN DAM

CUTTER OF

DIAMONDS

CUTTING SHOPS:

ANTWERP

41 Rue de la Province (Sud.)

CABLE ADDRESS, MADNAV

NEW YORK

437-439 Fifth Ave.
Cor. 39th St. Knabe Bldg.

TELEPHONE, 5879 38TH ST.
CABLE ADDRESS, DEVRIVAN

AMSTERDAM

55 Ruysdaelstraat

CABLE ADDRESS, MADNAV

LONDON OFFICE, 22 Holborn Viaduct

THE HERMAN KECK MANUFACTURING CO.

CUTTERS OF

DIAMONDS

19-21 WEST FOURTH STREET CINCINNATI, OHIO

OPPENHEIMER BROS. & VEITH.

CUTTERS OF DIAMONDS.

CUTTING WORKS

43-45 47 JOHN STREET

65 NASSAU STREET,

NEW YORK.

AMSTERDAM
2 Tulpstraat

LONDON
40 Holborn Viaduct

MEYEROWITZ BROS.

IMPORTERS OF

DIAMONDS

PRECIOUS and
SEMI-PRECIOUS STONES

ESTABLISHED 1896

NEW YORK: 37-39 Maiden Lane
PARIS: 58 rue de Maubeuge
AMSTERDAM: 2 Tulpstraat

MEYEROWITZ BROS

MEYEROWITZ BROS

band is a jeweler and a worker in horn. There are many others, and the numbers are steadily increasing since the opening of the classes for jewelry at the Sir John Cass Institute, and the Central School of Arts and Crafts, though the latter is only open to those who are apprenticed to the trade. As the supply increases, let us hope that public taste will improve also; more people appreciate good jewelry now than nine or ten years ago. The trouble is that so many do not know the difference between the really good and the would-be good.

Frequently when this new movement is referred to, it is confounded with that curious phase known as "Art Nouveau." Now nothing could be further removed from the remotest resemblance to "Art Nouveau" than the direct and simple methods of these workers. "Art Nouveau" never received such encouragement in England—meaningless wriggles and worn women with streaming hair, pendants and clasps which resemble nothing on earth but the pelvic bones of a skeleton somewhat deformed—then the pansy done in horn, true to life in form and color—probably a half-faded pansy with tired petals at that. We realize that all this is not art.

The skilful work of the two Frenchmen who exhibit in London, Lalique and Galliard, cannot be ranked with this. One must admire their workmanship; they have a subtle sense of color, and a fine choice of materials, but they are so absorbed in the prettiness of things, or in their desire to be new or eccentric, that they lose sight of the essential.

I came across a photograph of a jewel of M. Galliard not long ago. It appeared to be a compromise between a beetle, a skeleton and a woman—that is, some of the characteristics of each were introduced into the design, with most unhappy results. Even the skill of the workmanship, the beauty of the material or the fineness of color cannot reconcile one to these eccentricities. The rage to be new blinds them to disturbing results. A beautiful design always has the virtue of repose—the restlessness and uneasy groping for novelty cannot lead to beautiful and satisfying results.

(Continued in the issue of March 4.)

List of Watches and Jewelry Recently Stolen from the Store of O. P. Davis, Ault, Colo.

AULT, Colo., Feb. 12.—Thus far no clue has been obtained to the thieves who robbed the store of O. P. Davis, of this place, Jan. 9. The goods stolen consist of five gents' solid gold rings, 18 ladies' solid gold rings, 16 vest chains, stamped S. O. B., A. A. G., R. F. S., E. & S. J. Co.; 34 complete watches of Elgin and Waltham make, in solid cases filled and solid gold as follows:

Elgin, 18 size, 17 jewel.....No.	13582570
Elgin, 16 size, 15 jewel....."	13612140
Elgin, 12 size, 15 jewel....."	12892617
Elgin, 12 size, 17 jewel....."	12726625
Waltham, 18 size, 17 jewel....."	15092345
Waltham, 18 size, 15 jewel....."	14451107
Waltham, 18 size, 7 jewel....."	14603045
Waltham, 18 size, 15 jewel....."	13991258
Waltham, 16 size, 16 jewel....."	12549266
Howard, 16 size, 17 jewel, Crescent case, No. 7760998; movement....."	938923
One 20-year, Crown, O. F., 18 size...."	8517987
One 20-year, Crown, O. F., 16 size...."	8981710
One 20-year, Crown, O. F., 12 size...."	8992420
One 20-year, Crown, O. F., 12 size...."	8458977
One 20-year, Crown, Htg., 16 size...."	8381328

One 20-year, Crown, Htg., 6 size.... "	8792628
One 20-year, Crown, Htg., 6 size.... "	8702859
One 20-year, Boss, Htg., 16 size.... "	7783517
One 20-year, Boss, Htg., 12 size.... "	7738217
One 25-year, Boss, Htg.	
One 25-year, Crescent, O. F., 12 size. "	1598650

Officers Elected by Philadelphia Jewelers' Club at Annual Meeting—Preparations for Annual Banquet Completed.

PHILADELPHIA, Pa., Feb. 12.—The annual meeting of the Philadelphia Jewelers' Club last night at the club rooms, Chestnut St. near 13th St., was perhaps the most enthusiastic meeting of the club ever held. One thing is certain, that there was a larger attendance than ever before, and that each and every member took an active interest in the election for officers and the completion of arrangements for the next annual dinner of the club to be given on Washington's birthday anniversary, Saturday evening, Feb. 22, at the Bellevue-Stratford Hotel.

The election of officers resulted as follows: President, Col. J. Warner Hutchins; vice-president, Henry Bodenheimer; secretary, A. J. Le Jambre; treasurer, William H. Long. Board of Governors: L. P. White, Joseph E. Cadwallader, William Linker, A. Rutherford and A. G. Lee. These officers are the same as for the last year. Col. Hutchins was unanimously elected and carried the rest of the ticket with him, although there were half-hearted contests over some of the other officers. Even the outgoing Board of Governors was successful in being re-elected as an entire body, although changes are usually made in the personnel of the board.

The reports of Mr. Long and Mr. Le Jambre showed that the organization is in a flourishing condition financially and that during the year just ended the attendance has increased greatly. The increased attendance is largely attributed by the members to the fact that billiard, shuffleboard and pool tournaments have enlisted the interest of the members.

After the election Col. Hutchins thanked the members for the honor conferred upon him by re-election as their president and expressed especial gratification at the fact that his election was unanimous. He asserted that he would make every effort to advance the interest of the club during the present year. Col. Hutchins then appointed the following committees to have charge of the annual dinner:

Dinner Committee—L. P. White, chairman; William Linker, Joseph E. Cadwallader, Archibald Rutherford and Adelbert G. Lee.

Reception Committee—Henry Bodenheimer, chairman; George W. Read, John D. Battin, Frank L. Wood, Louis H. Eisenlohr, Charles E. Berry, Jacob Alburger, Alphonse J. Le Jambre, Robert C. Green, Jr., William P. Sackett, William H. Thompson, Jr., J. E. Simonson, Harry Oliver, T. Zurburg, H. D. Stevens, Benjamin F. Griscomb, Louis J. McGrath, E. L. Weil, Frederick Keim, John B. Leifried, William S. Moore, Otto Eisenlohr, J. Clifford Wilson, William H. Platt, Samuel Collins, Charles F. Duffy, William C. Earle, Matthias Stratton, Jr., John D. Pettingill, S. B. Kent, E. H. Eckfeldt, N. B. Eltinge, Frank Kind.

John A. Lehman, Charles L. Power, T. J. Mooney, Julian G. Hall, M. V. Burton, Charles L. Beckley, W. L. Washbourn, George B. Osborn, Frederick Bloch, William H. Long, Louis F. Muller, Jacob Binder, Jr., Howard E. Stevenson, C. M. Fogg, Harry P. Sauers and Horace Lockwood.

The following is the list of speakers who are expected to attend at the dinner of Feb. 22 at the Bellevue-Stratford: Hon. Edwin S. Stuart, Governor of Pennsylvania; Hon. John E. Rebyburn, Mayor of Philadelphia; Hon. J. Hampton Moore, Member of Congress from Philadelphia; Hon. John Barrett, member Deep Waterway Commission; Hon. J. E. Ransdell, Member of Congress from Louisiana; Hon. J. H. Small, Member of Congress from North Carolina; Hon. Charles F. Warwick, former Mayor of Philadelphia; Hon. E. S. Wilson, New Jersey; H. C. Larter, president of the Jewelers' 24-Karat Club, New York; M. N. Smith, president of the Boston Jewelers' Club; Leo Wormser, president of the Jewelers Board of Trade; A. B. Millar, Harrisburg, Pa., and Col. J. Warner Hutchins, Philadelphia.

Jewelry, Clocks, Watches, Silverware and Kindred Lines Exported from New York.

WASHINGTON, D. C., Feb. 12, 1908.—The following were the exports of jewelry, silverware, optical goods, clocks, watches, and kindred lines from the Port of New York for the week just ended:

- Bahia: 4 cases plated ware, \$537.
- Berlin: 3 cases clocks, \$634.
- Bremen: 2 cases jewelry, \$650; 2 cases silverware, plated ware, \$125; 8 cases watches, \$3,630; 10 cases watches, \$4,340.
- Calcutta: 26 cases clocks, \$515; 1 case watches, \$314; 3 cases scopes and views, \$134; 132 cases clocks, \$1,915.
- Colon: 13 cases clocks, \$134.
- Fayal: 5 cases clocks, \$163.
- Guayaquil: 1 case watches, \$375; 1 case jewelry, \$230.
- Hamburg: 7 cases clocks, \$385; 2 cases optical goods, \$147; 9 barrels jewelers' sweepings, \$9,000; 1 case jewelry, \$500.
- Havre: 7 cases plated ware, \$5,105; 6 cases jewelry, \$1,061; 3 cases watches, \$7,501.
- Havana: 3 cases clocks, \$117; 15 cases clocks, \$212; 1 case silverware, \$239; 2 cases plated ware, \$249.
- Hobarth: 1 case plated ware, \$163.
- Kingsston: 1 case plated ware, \$101.
- Lisbon: 33 cases clocks, \$460.
- Liverpool: 61 cases clocks, \$1,129; 66 cases clocks, \$1,053.
- London: 2 cases jewelry, \$486; 1 case optical goods, \$319; 1 case watches, \$850; 2 cases clocks, \$123; 6 cases watches, \$715; 1 case jewelry, \$124; 1 barrel jewelers' findings, \$200.
- Melbourne: 22 cases clocks, \$292; 20 cases clocks, \$505; 1 case optical goods, \$176.
- Mexico: 1 case plated ware, \$235; 1 case watches, \$659.
- Montevideo: 12 cases plated ware, \$1,386; 9 cases plated ware, \$804; 1 case clocks, \$100.
- Osaka: 16 cases clocks, \$179.
- Pernambuco: 8 cases plated ware, \$954; 12 cases clocks, \$212; 3 cases jewelry, \$575.
- Puerto Plata: 1 case watches, \$105.
- Rosario: 1 case watches, \$356; 4 cases optical goods, \$2,150.
- Southampton: 8 cases watches and material, \$1,622; 92 cases clocks, \$3,235.
- Sydney: 44 cases clocks, \$1,128; 7 cases scopes and views, \$709; 188 cases clocks, \$3,425; 4 cases optical goods, \$685; 2 cases watches, \$1,241; 19 cases plated ware, \$1,606; 50 cases clocks, \$831.
- Tumaco: 10 cases watches, \$175.
- Valparaiso: 17 cases plated ware, \$840; 3 cases watches, \$1,323; 66 cases clocks, \$1,807.
- Wellington: 1 case watches, \$125; 84 cases clocks, \$1,689; 21 cases watches, \$674; 2 cases plated ware, \$121.
- Zanzibar: 1 case watches, \$134.

To show our absolute confidence in the stability of the prices of Diamonds we will add to all bills purchased from us, from this date on, the following guarantee:

If at maturity of this bill the market prices are less than those charged for the above goods, we guarantee to refund the difference between the then existing market prices and the prices charged on this bill.

CYRUS PRICE & COMPANY
NEW YORK

Pittsburg Jeweler Causes Arrest of Two Men Believed to be Check Swindlers.

PITTSBURG, Pa., Feb. 13.—C. A. Fletcher, alias Otto Vonderles, and A. R. Michell, alias Frank Howard Wasson, two fashionably dressed young men, were arrested here yesterday afternoon by Detectives Porter and Roach while they were endeavoring to pass bogus checks in the jewelry store of H. M. and L. M. Smit, Fifth Ave. and

consulted with his brother, L. M. Smit, and it was decided to call up detective headquarters. Within five or six minutes the two officers who made the arrest were on the scene.

The men were allowed to pick out whatever they wanted, and in this manner their attention was held until the officers appeared.

Fletcher posed as an automobile demon-

complete outfit for turning out checks at will, fully certified. The stamp taken from the men was identical with the stamp on the check of the Mutual Bank.

The map found on them caused the police to believe they had started out from New York, the first stop being Washington. After Pittsburg was visited they were to go to Cleveland, Cincinnati and then Indianapolis, Chicago, Salt Lake City, San Francisco and Los Angeles. It may be that the men have already been in Cincinnati, for several swindling schemes have been perpetrated there.

The Smit brothers have been highly complimented for their good judgment in notifying the police, thus causing the arrest before the men could get away.

Involuntary Bankruptcy Proceedings Begun Against the Frankfurt Loan Co., Norfolk, Va.

NORFOLK, Va., Feb. 12.—An involuntary petition in bankruptcy was filed last week in the United States Court against the Frankfurt Loan Co., a corporation doing a pawnbroking business at 378 Main St., against whom the formal allegations of bankruptcy were set forth.

The creditors filing the petition are E. Weinmann, Philadelphia, Pa., whose claim is \$3,459; the Paul R. Howard Co., Norfolk, whose claim is \$195, and P. R. Howard, of the same city, who alleges a claim of \$1,500.

It averred that on Feb. 7 the secretary, treasurer and general manager of the company, with the consent of both of the directors and stockholders, admitted in writing the insolvency of the firm, its inability to pay the debts and also a willingness to be adjudged bankrupts.



C. A. FLETCHER, ARRESTED AT PITTSBURG, PA.

Masters Way. At first the detectives thought that they might be mistaken in their men, but upon searching them they were found to have in their possession stamps bearing the names of several New York banks, by which they were enabled to turn out certified checks at will. A map drawn by one of them appeared to indicate cities to be worked, extending from New York to Los Angeles, Cal.

These same men are believed to have swindled several jewelers at Washington, D. C. The police authorities there telegraphed here to be on the lookout for the men, and when apprised of their arrest came on this morning. Detective-Sergeant Parham brought with him warrants for the arrest of the men, and they were taken this morning before United States Commissioner Lindsay and charged with having passed a worthless check on a merchant at Washington. As the crime was committed in the District of Columbia, the Federal authorities have the right to prosecute the case.

The two men, who were taken to Washington to-night, are believed to be the men who have been swindling jewelers in various part of the country and are regarded as a clever pair of swindlers.

The men entered Smit's jewelry store yesterday afternoon and negotiated for the purchase of a watch valued at \$40. One of the men asked if the firm would cash a check for \$110. It was drawn on the Mutual Bank of New York. H. M. Smit asked the location of the bank, and one of the men gave a street corner on which Smit, of his own knowledge, knew no bank was located. He at once became suspicious and

strator for a famous French make, and Michell said that he was his machinist. The check which they produced was apparently certified to by the cashier of the Mu-



A. R. MICHELL, ARRESTED AT PITTSBURG, PA.

tual Bank, but was made payable to bearer, and this also caused suspicion.

When the men were taken to detective headquarters Captain of Detectives McGough was at first loath to hold them, as they had not done anything. It was decided to search them, however, and this led to the discovery that the pair carried a

The matter was put in the hands of Referee in Bankruptcy D. Lawrence Groner, who has appointed E. R. Wells, G. R. Swink and Frank C. Miller, receivers, under bond of \$10,000. The receivers took immediate charge of all the property of the company and started to take an inventory of the same.

Not One Stone

has ever come near attaining the popularity of the Reconstructed Ruby—the Hope Sapphire following next. * * * Comparatively inexpensive, these two Gems are within the reach of all, their demand increasing rapidly with their introduction to the general public. * * * We have realized that these Scientific Gems are articles that have come to stay, and have accordingly equipped ourselves for their uninterrupted production. Our facilities for cutting these stones enable us to fill all possible orders without delay.

L. Heller & Son

Importers of Precious and Imitation Stones
68 NASSAU STREET, NEW YORK

PARIS
39 Rue de Chateaudun

PROVIDENCE
212 Union Street

IDAR
14 Hauptstrasse

ORDER

DIAMONDS

ON MEMORANDUM FROM

ALFRED H. SMITH & CO.

London,
5 Holborn Viaduct.

170 BROADWAY, NEW YORK
Corner Maiden Lane.
Also 475 FIFTH AVENUE

Chicago,
103 State Street.

HIRSH & HYMAN,

IMPORTERS AND CUTTERS OF



2 MAIDEN LANE, NEW YORK

Broadway-Maiden Lane Building

Gems and Precious Stones

Cloth, Postpaid, \$1.00

Published by

The Jewelers' Circular Pub. Co.

11 John Street

NEW YORK

RUDOLPH NOEL

RUDOLPH NOEL & CO.

PHILIP NOEL

IMPORTERS AND CUTTERS OF DIAMONDS

2 Tulp Straat, AMSTERDAM

37-39 Maiden Lane, NEW YORK

TO CHANGE THE NAME OF THE JEWELERS' LEAGUE.

Adjourned Annual Meeting to be Held at the Astor House, New York, Feb. 27, to Act on Constitutional Amendments Making it the Assurance League of America.

As recently noted in THE CIRCULAR-WEEKLY, an important step was taken at the last annual meeting of the Jewelers' League, when the question of changing the name of the organization to one of more general character was discussed. The discussion was precipitated by the following resolution, which was adopted in full:

Resolved, That it is the sense of this meeting at the time has now arrived, when we believe it will be to the best interests of this league and its members, to make a change in the present name of this organization, to such a name as will not be specially identified with any trade or occupation, and believing that the same will greatly assist in the growth, prosperity and strength of this organization, we therefore instruct the executive committee to decide upon a name for the league, which in their judgment will be most beneficial, and to take such action as may be necessary for the adoption of such a name as they may decide upon at a special meeting of the members to be called by the chair at the earliest possible date.

In pursuance of the resolution, the executive committee met and unanimously recommended "The Assurance League of America," as a substitute for the present name and the recommendations of the committee, carrying with them recommendations of proposed amendments of the constitution to put change into effect will be acted upon at an adjourned annual meeting to be held in Parlor 74 of the Astor House, Broadway and Barclay St., New York, Feb. 27, at 3 P. M.

The following are the proposed amendments which will be submitted for adoption when the meeting is held:

Amend Section 1 of Article I.—By striking from said section the words "Jewelers' League of New York," and insert in lieu thereof the words "Assurance League of America."

Amend Section 4 of Article I.—By striking from said section the word "Jewelers'" and insert in lieu thereof the word "Assurance."

Amend Section 1 of Article VI.—By striking from said section the word "Jewelers'" and insert in lieu thereof the word "Assurance."

Amend Section 5 of Article VIII.—By striking from said section the word "Jewelers'" and insert in lieu thereof the word "Assurance."

Jewelry Salesman Accused of Stealing Stock Worth \$15,000, Brought to New York and Held for Trial.

Harry Levinsohn, who was formerly a traveling salesman for Freudenheim Bros. & Levy, 54 Maiden Lane, and who was arrested in Chicago on a charge of stealing jewelry from his employers, was returned to New York last Wednesday by Detective Donahue, and was held in \$4,000 bail by Magistrate Corrigan in the Tombs police court Thursday to await the action of the grand jury.

In speaking to a CIRCULAR-WEEKLY reporter relative to the arrest of Mr. Levinsohn, Mr. Levy, of the firm, said that the salesman had been in their employ about a year, and that up to this time they had had confidence in him. He said that Levinsohn had made a practice of sending goods to an old employe and this man pawned them, and that this fact was discovered by accident.

It was expected that the salesman, who was traveling on the Pacific Coast, would return to New York about Dec. 15, but

he did not return at that time and gave several reasons for not coming back. He returned to Chicago Feb. 1, and on Feb. 3 came on to New York, but did not put in an appearance at the office. Mr. Levy said that the man to whom the jewelry had been given confessed to the pawning of the goods, and that the matter was put into the hands of the Jewelers' Protective Union, who turned it over to the Pinkerton detectives. Mr. Freudenheim, who was in Pittsburg at that time, was informed of the matter and went to Chicago, where he met the salesman, who made a full confession of the matter to him and gave up the trunk, goods and pawn tickets.

The reason given to Mr. Levinsohn for his salesman's uncalled-for action was that he had old debts to pay, and that he used the pawned goods to meet these debts. He pawned in all about \$15,000 worth of stock, on which he realized about \$10,000, and nearly all the tickets for this have been recovered. Mr. Levy said that the man was receiving a good salary, and that there was absolutely no reason for his act.

Death of Christian Irion.

MANCHESTER, N. H., Feb. 12.—Christian Irion, an old and at one time a well-known jeweler of this city, who for a number of years had a store on Elm St., passed away last week at the county farm at Grasmere, where he had been an inmate for the past five or six years. The funeral services were held Saturday and the remains were interred in Pine Grove Cemetery.

Mr. Irion was born in Stuttgart, Germany, about 60 years ago and came of an excellent family. He came to this country in early life, and about 1882 started his career as a jeweler in Manchester, succeeding Wm. Carter, by whom he had previously been employed. He conducted business near the Old City Hotel, on Elm St., for a number of years, but later the business proved unprofitable and he finally abandoned it. His wife and two children died some years ago, and he then went to the county farm, where he spent the remainder of his days. Death was due to a gradual breaking down of his system.

Death of John Campbell.

COHOES, N. Y., Feb. 12.—John Campbell, who died last week, was for many years a prominent jeweler, stationer and dealer in fancy goods, and the news of his passing was received with regret by many of his old friends in the jewelry trade. He is survived by a widow and two brothers.

Deceased, who was about 60 years of age, was a native of Glasgow, Scotland, but had lived in Cohoes since he was a child. He began business nearly 30 years ago and built up an excellent trade. At one time his store was one of the largest and most important, but of recent years he had not been doing business on as large a scale.

G. H. Hadley, formerly of Bedford, Ia., is now at Frederick, Okla.

Boys Confess the Selling of Silver Scrap and Spoons Stolen from Attleboro Manufacturers.

Arthur Douya, Edward Inglis and John Duffy were before Judge Byram, in the district court, last week, on a charge of larceny of a quantity of silver scrap. They disclosed an unusual story, and Judge Byram continued their cases until he could consult with Agent G. Frederiek Davis, of the State Board of Charity, from Fall River, as to a disposition of them. When the cases were later called the boys were held in \$100 each for the final disposition of their cases, Feb. 18.

The warrants against the three boys alleged that they were implicated in the larceny of a quantity of silver scrap from the J. T. Inman Co. and Watson & Newell Co. factories. Duffy was the first boy to testify.

He said he was employed in the packing room of the J. T. Inman Co. One noon hour several weeks ago he found some silver in the scrap box, and took it. Douya and Inglis tried to sell it, but were unsuccessful, and hid it in a pile of coal. Later one Peter Monahan got the stuff and tried to sell it in Pawtucket, with the result that he was arrested by Detective Henry, of the Pawtucket police.

Eddie Inglis told of taking 17 silver spoons from the scrap can at the Watson & Newell Co.'s factory. He and Douya went "junk hunting" one Saturday Douya got into the big scrap receptacle and located 17 sterling silver spoons. Inglis said he watched Douya throw them out of the can.

Douya took the spoons to a store and sold them for 30 cents. Inglis said he got 15 cents of the money Douya received.

According to Inglis, Douya went to a refinery on Union St. and sold the spoons for \$8.46. He divided the money with Inglis, and the pair went to Pawtucket.

Inglis said he did not know that the spoons were any good when they were found. He did not believe it would be stealing, he said, to take the spoons after they had apparently been thrown away. He admitted, however, that they were looking for money for the stuff.

Douya told practically the same story as Inglis. He said he told the man in the refinery that the spoons belonged to his grandfather, and the refiner bought them for \$8.46. At the Watson & Newell Co.'s factory it is understood that quiet inquiry is in progress to learn how the spoons came to be where the boys found them.

Peter F. Monahan was arraigned before Judge Byram on a charge of larceny and receiving stolen property valued at not more than \$100. It is alleged that he received a quantity of silver taken from the two factories named above.

Monahan pleaded not guilty to the larceny charge and guilty of receiving the property, resulting in a light fine. Monahan was unable to pay and was taken to jail.

Fire recently did damage to the store of L. Alva Lewis, Klamath Falls, Ore., amounting to \$2,000.

Henry M. Roberts, Dickinson, N. Dak., who occupied a portion of the Messersmith store, which was destroyed by fire, recently, lost a large stock of jewelry.

REGISTERED



TRADE-MARK

AMETHYST JEWELRY

REGISTERED



TRADE-MARK

We have many beautiful and striking pieces in amethysts and combinations of amethysts and pearls, and amethysts and diamonds.

The popularity of amethyst jewelry makes this exceptionally salable stock, and you should certainly have a few representative pieces.

We carry Rings, Necklaces, Brooches, Scarf Pins and La Valliere.

If you have our catalog, well and good—If you haven't, send for it.

REGISTERED



TRADE-MARK

HAYDEN W. WHEELER & CO., Importers
2 Maiden Lane, NEW YORK, N. Y.

REGISTERED



TRADE-MARK

AMSTERDAM, 2 Tulp Straat

Phone 7365 Cortland

LONDON, 50 Holborn Viaduct

STERN BROS. & CO.,

CUTTERS OF

DIAMONDS,

CUTTING WORKS:

138-142 West 14th St., N. Y.

68 Nassau St.,

NEW YORK.

CHICAGO,

103 State Street.

LONDON.



29 Ely Place.

== PENDANTS ==

Our Spring line of 14 Kt. Baroque Pearl and Colored Stone Pendants is very complete both in design and price, the latter ranging from \$2.00 up.

CROSSMAN COMPANY

3 MAIDEN LANE : : : : : NEW YORK

 When A 
Customer Wishes
To Sell

YOU any lot or single piece of mounted diamond jewelry—large or small—do not turn him down absolutely, send the goods to me for a

SPOT CASH OFFER

and save all trouble and worry. I pay all express charges and insure the goods in transit. I have been in the business right here for 16 years, and can give the very best references as to responsibility on application. Offers and valuations furnished promptly. Write for further information.

J. J. COHEN

1011 Chestnut St.

Philadelphia, Pa.

Established 1891



Charles Wagenfot

Die Sinker.

140 West Broadway

New York.

R., L. & M. FRIEDLANDER

IMPORTERS OF

DIAMONDS

30 MAIDEN LANE, - - - NEW YORK CITY

Bankruptcy Trustee Brings Suits to Determine Pawnbrokers' Rights to Articles Pledged by One Who Doesn't Own Them.

There will come up in March in the Supreme Court in New York two cases of much interest to the trade as dealing with the question of the right which a pawnbroker has to hold goods received by him from a person not the lawful owner and not rightfully entitled to pawn them. The cases in question are those brought by Chas. S. Mackenzie, as attorney for R. L. Wood, as trustee in bankruptcy of Edelhoff Bros. & Co., against Thomas Simpson, conducting a pawn broker's business under the name of R. Simpson & Co., at 143 W. 42d St.

The complaint in the first case alleges that Mr. Wood, as trustee for Edelhoff Bros. & Co., is the owner and is lawfully entitled to the possession of a pearl necklace valued at \$8,500, and goes on to say that Edelhoff Bros. & Co. were at one time, in 1906, the owners of the necklace, and that Conrad Schickerling represented to Edelhoff Bros. & Co. that he had a customer who desired to purchase the necklace, and he obtained from Edelhoff Bros. & Co. the necklace for the purpose of exhibiting the same to the customer and of effecting a sale, if possible, for the benefit of Edelhoff Bros. & Co. at the price of \$12,500. It is further alleged that on Feb. 15, 1906, Schickerling wrongfully and illegally pledged the necklace with the pawnbroker in this action for his own benefit without the consent of Edelhoff Bros. & Co.

The complainant further states that the plaintiff demanded the return of the necklace, and the defendant refused, and still refuses, to return it, and that the necklace is wrongfully detained by the pawnbroker, and judgment against the defendant for the recovery of the necklace or for the sum of \$8,500, together with the cost of the action, is asked.

In the second case it is alleged that on Jan. 29, 1905, that the corporation of Edelhoff Bros. & Co. had in its possession and owned jewelry valued at \$17,671, consisting of 13 diamond pins and 11 diamond rings, which, it is alleged, were unlawfully pledged on Jan. 31, 1906, by Conrad Schickerling with the defendant, Thomas Simpson, the pawnbroker, to whom was delivered a pawn ticket No. 1,423; also that 16 diamond pins and 15 diamond rings were also pledged in February, 1906, and at the same time 16 diamond pins and 20 diamond rings were also alleged to have been pledged by Conrad Schickerling. It is further alleged in the second complaint that about Jan. 29, 1906, Gustave Edelhoff, without right or authority from Edelhoff Bros. & Co., obtained these chattels from Edelhoff Bros. & Co. and delivered them to Conrad Schickerling, and that Schickerling pledged them with the defendant for his own use without the consent of Edelhoff Bros. & Co. as security for loans made by the defendant to Schickerling.

It is claimed that the loans were for the benefit of Schickerling and not for the use of Edelhoff Bros. & Co., and the money derived by Schickerling was applied to his own use. It is contended that the defendant in this action did not acquire any lien or special property in the goods by virtue

of the pledges, and that the goods were wrongfully and illegally pledged, and that Edelhoff Bros. & Co. were entitled to the immediate possession of the goods pawned until the appointment of the trustee of Edelhoff Bros. & Co. in bankruptcy, at which time the title to the property came into the possession of the trustee. A demand for the return of the jewelry is made and judgment for \$17,671 is asked.

In speaking of the cases which have been brought by the trustee in bankruptcy against the pawnbroker, Mr. Mackenzie, as attorney



ALBERT C. WARD. HAVE YOU SEEN HIM?

for the trustee, said that the theory on which the actions are based is that the goods were wrongfully taken by Schickerling from Edelhoff Bros. & Co., and since Schickerling is alleged to have stolen the goods from Edelhoff Bros. & Co., Simpson, the pawnbroker, acquired no better right to the goods than Schickerling himself, and this action in replevin is to get back for Edelhoff Bros. & Co. the goods taken.

Mr. Mackenzie stated that the law is clear that a person from whom chattels are stolen can recover them from any person in whose hands they may be found, whether that person is an innocent purchaser for value or not, but that in cases of pawning, such as those in the suits instituted by Mr. Wood, as the trustee of Edelhoff Bros. & Co., there are many different questions of law involved on account of the peculiar relation existing between Conrad Schickerling, the organizer and ostensible backer of Edelhoff Bros. & Co., and Gustave Edelhoff, the president of the corporation.

Fred R. Coats, Springfield, Ill., will leave soon for Lima, O., where he will make an effort to secure the machinery of the disbanded Appleton Watch Co. for the purpose of equipping a new watch factory for Springfield. The Appleton Watch Co. started in the watch manufacturing business at Appleton, Wis., but later removed to Lima, O., where it disbanded. The machinery has since been stored. It has been announced by Mr. Coats that he is at work at the present time perfecting a new scale for the weighing of diamonds, and in a short time will place this article on the market.

Beware of This Man Whom the Police Say Is Offering Worthless Checks to Jewelers.

Detectives in New York are at work trying to locate a man who has been attempting to pass bogus checks on several large New York jewelers in the past week. The man is known to the police as Albert C. Ward, although he uses several other names. He is described as being 74 years old, weight 139 pounds, gray hair, smooth face, teeth nearly all gone, a bit over six feet tall and with prominent cheek bones.

He is said to be a native of Kentucky, and was at one time a horse dealer.

Jewelers in New York and throughout the country are warned to look out for this man.

Importations at the Port of New York.

Weeks Ended Feb. 9, 1907, and Feb. 8, 1908.			
	1907.	1908.	
China, Glass and Earthen Ware:	1907.	1908.	
China	\$71,722	\$37,347	
Earthen ware	7,733	12,605	
Glass ware	16,112	15,324	
Instruments:			
Musical	4,689	9,904	
Optical	5,624	6,173	
Philosophical	1,695	484	
Jewelry, etc.:			
Jewelry	16,561	24,598	
Precious stones	1,160,856	71,067	
Watches	25,511	27,779	
Metals, etc.:			
Bronzes	2,441	300	
Cutlery	11,340	25,574	
Dutch metal	1,526	
Plated ware	
Platina	71,204	
Silverware	57	148	
Miscellaneous:			
Alabaster ornaments	445	5	
Amber	2,045	1,786	
Beads	1,987	1,493	
Clocks	2,133	1,725	
Fans	2,544	4,808	
Fancy goods	10,018	5,438	
Ivory	752	
Ivory, manufactures of..	588	188	
Marble, manufactures of.	27,032	4,537	
Statuary	10,541	789	

Thomas L. Gibbon, until recently in the employ of C. G. Schulze, Halifax, N. S., died about a week ago at his home, at 230 Argile St., that place, aged 57 years. Death was caused by pneumonia.

NEW ENGLAND MANUFACTURING JEWELERS' & SILVERSMITHS' ASSOCIATION.



Winter Banquet

AT INFANTRY HALL, PROVIDENCE, R. I.

Saturday Evening, February 15, 1908

PROVIDENCE, R. I., Feb. 17.—Jewelers from all over New England gathered Saturday evening in Infantry Hall in this city, the occasion being the annual banquet of the New England Manufacturing Jewelers and Silversmiths' Association. The association well maintained its reputation for elaborate and successful dinners, the large hall never before in its history having been the scene of such a large banquet. To add to the enjoyment ex-Senator Jos. S. C. Blackburn, Governor of the Panama Canal Zone, was present and delivered a stirring address on the "Panama Canal," during which he stated that he looked to see the canal completed within five years, and that the estimated costs would be \$300,000,000. Rev. Dr. Willard Scott, of Worcester, Mass., a prominent figure at all the banquets, spoke in a humorous vein and took for his subject "What's Yours Is Mine and What's Mine Is My Own." William O. Morse, of Boston, ex-State Senator, was also a speaker.

Just previous to the dinner, the call of which was sounded at 7 o'clock, a reception was held, and it was not until Fay's Orchestra had started up the "Second Connecticut March" that the immense gathering (fully 450 jewelers and their friends being present) took their seats at the tables. The band played throughout, classical music mixed with popular selections keeping everyone in good cheer. At each plate was a Morocco leather traveling bag in miniature, and upon opening it there were trays such as the salesmen carry with menu cards bearing the pictures of President Harry Cutler and ex-Senator Blackburn, together with a list of the speakers. At the bottom of the case there was a large tray, and upon pulling it out each guest found two cigars and a match safe. It was a unique souvenir, and caused much favorable comment.

The decorations were of the most elaborate sort and very striking in effect. The color scheme was gorgeous, green white and pink white bunting and American flags in profusion being arranged about the hall in a way to command general approval. The stage itself was almost entirely obscured, a band of green and white bunting covering the proscenium arch, while potted plants relieved the bareness of the lower portion, bunting and flags draped artistically in the rear of the stage, while pink and white bunting covered the balcony rail.

From the corners of the hall long streamers composed of 13 stars on a blue field

and a red and white stripe each extended to the ceiling. At the rear of the hall on the balcony rail representations of the seals of Rhode Island and Kentucky were displayed.

Those seated at the president's table were Harry M. Mays, Lieutenant-Governor Ralph C. Watrous, George K. Webster, George W. Gardner, Collector of Port; Gen. Charles A. Wilson, United States District Attorney; Hon. William W. Douglas, Chief Justice of the Supreme Court;



HARRY CUTLER, PRESIDENT.

Rev. Frank J. Goodwin, Theodore W. Foster, Hon. William A. Mess, Hon. Henry G. Thresher, Toastmaster Harry Cutler, president of the association; Hon. Joseph C. S. Blackburn, Rev. Dr. Willard Scott, Governor James H. Higgins, Mayor P. J. McCarthy, George H. H. Holmes, Henry D. Sharpe, Frank O. Field, Frank T. Pearce, Fred A. Lawton and Albert A. Bushee.

When the inner man had been satisfied President Harry Cutler of the association arose to open the postprandial exercises. During the course of his remarks he said:

PRESIDENT CUTLER'S REMARKS.

During the past five years, and since the inception of the present organization, we have made marked progress under the able leadership of recent administrations, so that not only has the ancient respect for the craft been rejuvenated, but we have exerted a potent influence upon those

inclined to disregard the honesty of our product. We were the instrument through which legislation was enacted, like the stamping which does insure the reputation of the manufacturer and dealer, besides protecting the consumer. Many measures of vital importance have been accomplished, but above all, a feeling of regard has been established among members of the craft and is being strongly welded into dissoluble links. It is supplanting the distrust and suspicion, which heretofore obtained among those making a similar product. Such feeling cannot help but redound to the advantage of the industry. It creates that deep respect for another, which arises from the constant interchange of ideas, from the rubbing of elbow with elbow, so to speak, and from standing shoulder to shoulder.

So, in contemplating the horizon, a bright and profitable future for this corporation and the industry in general is presented. We are so young in our infancy. We have many things to learn and develop, which are bound to make us useful members of an important industry, as well as useful citizens of a great industrial center.

In the year just passed our trade has enjoyed one of its most successful periods, and were not for the panic that assailed us in October, it might have been reckoned as one of the most prosperous years in the jewelry business. However, jewelers, as such, have most buoyant natures, and in prosperity or adversity, happily their greatest asset is hope; and so while recognizing that our profession is a luxury, but its component parts largely of base metal or of material of the most intrinsic value, and realizing that our trade is the very first to feel the depression and the last to recover from such is the atmosphere that permeates our craft, that hope is never lost. Furthermore, knowing that our customers will not buy a collar button or scarf-pin to keep the body warm, or a watch chain to stave off hunger, yet such is our faith in the prosperity of our God-given, natural resources that the adornment which man has been heir to from time immemorial is still and always will be a certain necessity.

This accounts for our buoyancy of spirit regardless of where our funds are suspended, or the realization of the havoc played by presidential campaigning or the uncertainty of tariff tinkering.

As for the immediate future, our new one for 1908, which has been set before you, is bristling with design and quality, which should make every representative eminently successful in presentation the same, and although unauthorized by our boards of governors, I herewith charge each of you to accept the sample case prepared for you and be come our most ardent drummer.

In behalf of the members who are making wedding rings, I may say that they claim to lay the greatest panacea against that grave peril of vital subject "race suicide."

In presenting to you the gentleman who has very reluctantly and after much urging, accepted the position of presiding officer of the postprandial exercises, it seems almost superfluous to indulge in an introduction, as he is well known to every one at the board. It is but fitting to say, however, that we are proud of the man, who represents one of the largest firms in this city, a man who has been honored by the city in general and our industry in particular; who has brought honor to every position to which he has lent his admirable talent. He is a loyal citizen, a respected colleague, and the author of the only celebrated case in the jewelry business, and like 90 per cent of



MEMBERS AND GUESTS OF THE NEW ENGLAND MANUFACTURING JEWELERS' AND SILVERSMITHS' ASSOCIATION, AT MID-WINTER BANQUET, HELD IN PROVIDENCE, SATURDAY, FEB. 15.

Chester Billings & Son

1840

Successors to

Kandel, Barmore & Billings

1908

**Importers of Diamonds
Other Precious Stones, and
Pearls, Diamond Jewelry**

1840, Kandel & Barmore; 1866, Kandel, Barmore & Co.; 1880, Kandel, Barmore & Billings; 1897, Chester Billings & Son

New York, 58 Nassau Street, 29 Maiden Lane

London: 22 Holborn Viaduct, E. C.

Paris: 53 Rue de Chateaubaud

Amsterdam: 2 Culp Straat

GEORGE H. HODENPYL.

WALTER N. WALKER.

HODENPYL & WALKER

IMPORTERS OF

DIAMONDS

OTHER PRECIOUS STONES
AND PEARLS

MANUFACTURERS OF
FINE DIAMOND JEWELRY

373 FIFTH AVENUE, NEW YORK

Corner 35th Street

Telephone, 5093 Madison Square

CHAS. F. WOOD & CO.

DIAMONDS

1 MAIDEN LANE

NEW YORK

EISENMANN BROS.

IMPORTERS OF

Pearls and Precious Stones

452 Fifth Avenue, New York

cor. 40th St., Knox Building

3 Rue St. Georges, Paris.

the members of this corporation he has risen from the ranks a self-made man in the truest sense that term implies. It gives me pleasure to present, as I know it does you all to meet formally, the toastmaster of the evening, Hon. Henry G. Thresher.

Toastmaster Thresher, after accepting the office in a graceful manner, referred to the failure of the Union Trust Co. and to the fact that the other banks, by coming to the rescue of the depositors in that institution, had given many manufacturing jewelers an opportunity to carry on their business even when their funds were tied up.

Hon. William A. Morse, of Boston, was introduced as the first speaker. He told several witty stories and delivered a strong address on the importance of a man having a singleness of purpose and a large stock of determination. His address was punctuated with scintillating wit which did not in any way detract from the thought he had in mind.

Rev. Willard Scott, of Worcester, the second speaker, convulsed his auditor from the outset. Mr. Thresher introduced him by reading a humorous poem, the subject of which was Dr. Scott. The doctor got back at the toastmaster by claiming authorship of the poem, and then for the next half hour had his listeners double up in laughter by firing story after story at them.

The address of the evening was delivered by Governor Blackburn, of the Panama Canal Zone, who explained in detail the work already accomplished on the Panama Canal, the difficulties that beset the engineers in charge of the work, and the history of the canal scheme. He prophesied that in years to come the canal will be the scene of the greatest battle for commercial supremacy that the world has ever known. He said that if the work is continued at the same rate that it has been pushed during the past eight months the canal will be open for navigation four years hence.

During Governor Blackburn's address James Otis, a manufacturing jeweler, was overcome by the heat and swooned. He was assisted out of the hall by friends, and when he reached the outer air he revived. Governor Blackburn was the last speaker and at the conclusion of his address the diners filed out of the hall. It was the most successful banquet that the association has ever held.

Those present were:

James B. Wetherell, Henry Dennis, James Hathaway, C. S. Finch, William H. Platt, E. Fuller, Charles T. Paye, William Kirk, Cyrus Brown, William Tefft, Newton P. Hutchins, George W. Hutchinson, Arthur T. Cobb, Ben Huestis, A. W. Holmes, G. R. Hussey, C. Broome, J. B. Congdon, L. H. Carpenter, Charles E. Hancock, William B. Peck, H. Blanchard Burham, John J. Buster, Joseph A. Holland, E. Knight, H. L. Manchester, H. A. Lincoln, Dr. E. Fisher, Wade W. Williams, Harold W. Ostby, Arthur O. Ostby, Harry B. Mead, Robert Smith, Thomas Hanley, William H. Stone, M. Dunn, W. C. Stevens, L. M. Lincoln, W. C. S. Mays, Jules P. Goldstein, Arthur C. Stone, W. Possner, William J. Lind, C. H. Fuller, C. Fuller, George Briggs, Jr., William J. Pearce, J. M. Fraser, C. H. Butts, Charles F. Ellis, William Clark, Jr., Frank H. Gladding, W. H. Saa, G. Fred. Solsman, H. Fulford, H. J. Straker, Joseph E. Straker, William B. Hart, Jr., R. Thompson, D. C. Eggleston, William J. Claiborne, Albert R. Kerr, E. R. Knight, Jr., C. S. Nightgale, H. F. Guile, W. N. Fisher, George C. Cormick, William H. Bell, Walter A. Grulith, J. White, R. J. Shoemaker, Jr., Fred Snelgro, Albert S. Vennerbeck, Samuel A. Brown, Grover C. Haberman, S. Lederer, Walter Lederer, William F. Leeder, J. D. O'Brien, Louis S. Hodges.

Leach, S. H. Garner, Rudolph Hofheimer, A. I. Baer, M. J. Baer, C. H. Eden, E. A. White, V. H. Richardson, E. O. Murry, Samuel Adams, George Moses, John J. Jenckes, Meyer Harzberg, James R. MacColl, George L. Shepley, J. Edward Studley, Charles H. Child, N. B. Barton, Louis N. Cook, M. E. Barriell, H. B. Richardson.

M. Bliss, Ira W. Smith, Jesse Carpenter, J. Bacon, Hubert C. Bliss, John R. Dennis, D. I. Wall, Aldridge G. Pearce, James O. Otis, W. Ross, E. Tudor Gross, Henry W. Harvey, W. Otis, Alaric R. Weck, Horace M. Peck, Harold Gross, J. P. Burlingame, E. I. Rogers, R. J. Rogers, William T. Chase, E. I. Rogers, Jr., J. I. Fanning, Fred D. Carr, Oscar E. Place, S. A. Baldwin, B. B. Manchester, Henry Fletcher, C. D. Kimball, A. W. Roubaud, S. D. Macpherson, W. Gardiner, L. J. Roehr, John C. S. Shoteds, Sidney H. Nordlinger, Henry O. Crandall, Charles I. Emerson, William E. Loser, H. S. Tanner, Horace M. Steere, J. Harris Potter, William H. Crafton, George E. Darling, Dr. Arthur S. Randall, C. Ray Randall, J. Parker Ford, J. Perry Carpenter, George Frey, William P. Cheever, W. Nye, Fred L. Carpenter, F. W. Gale, J. C. Taylor, Clarence S. Watson, Raymond M. Horn, J. E. Straker, Jr., Dr. John Hillman Bennett.

A. Howard, George D. Simmons, Harold D. Sweet, Joseph L. Sweet, W. E. Sweeney, M. E. Jenckes, Ezra S. Smith, A. L. Blumenthal, George Sweet, J. Porter Russell, J. M. Buffinton, John

atheote, Ira Wilson, Robert E. Budlong, L. H. Osworth, H. R. Wheeler, J. Allen Buffinton, Rancello G. Jillson, Charles I. Brown, Frank S. Mills, Isaac P. Foster, Theodore C. Foster, John

Brant, William O. Greene, R. Foster Reynolds, F. B. Reynolds, Robert C. Root, Samuel

Wild, Oliver W. Remington, A. K. Potter, Henry Englander, H. H. Tucker, Caesar Misch, Stanton E. Smith, A. H. Trudeau, Edgar W. Martin, L. C. Martin, E. S. Coleman, William

Lythgoe, Howard D. Wilcox, Dutee Wilcox, William P. Chopin, C. M. Dunbar, A. C. Messler,

Albert W. Smith, W. P. Chopin, Jr., William H. Heurer, S. C. Potter, C. D. Dunlop, E. B. Hough, Walter S. Hough, H. L. Carpenter, H.

Wilkinson, C. W. Batteny, John M. Batteny, D. Hayden, W. A. Schofield, William A. Copland,

William H. Perry, James F. Field, Henry Walcott, A. Greene, Joseph F. Rioux, F. V. Kermon,

eter Turner, Samuel Anderson, Harry E. Williams, Fred G. Warren, Walter E. Ensign, Sidney

Williams, Lester B. Cutler, P. E. Thayer, H. S. Burlingame, F. I. Baker, Frank T. Atwood, Arthur

Sylvester, Donald LeStage, Edward K. N. Cook, Peter Lind, F. B. Eddy, A. Leon Kilkenny,

Charles A. Eddy, P. S. Eddy, F. R. Eddy, Thomas M. Williams, Morton F. Winson, Gustave

Sacke, H. A. Carpenter, William F. Kilkenny, Frank N. Young, Edward I. Mulcahey, D. E.

Lakepace, Gus W. Standberg, George H. Sykes, T. Imman, Frank Mossberg, O. L. Barrows, A.

Ingraham, Henry S. Gelson, Frank M. Sturdy, Joseph A. Coddling, D. M. Baldwin, Henry S.

Walsh, Frank E. Farnham, Fred D. Thompson, Frederick R. Martin, E. F. Rueckert, George C.

Rueckert, E. A. Coddling, J. H. Tuttle, A. A. Clark, Calvin Dean, William H. Hansford,

Isaac H. Sisson, W. H. Welch, Samuel Moore, Joseph V. Broderick, Fred A. Aborn, J. S. Harris,

Frank B. Rhodes, Henry F. McCaffrey, Henry Lederer, S. Tollman, P. Wunderle, B. A. Bell,

Leon Penonoff, Louis W. Clarke, Joseph W. Martin, Jr., Charles S. Cassidy, F. E. Dodge, Charles

V. Douglas, Arthur D. Holland, H. M. Barry, Leo V. Mooney, Earl B. Williams, Edward H.

Parsons, H. F. Adams, Alvin N. Herrick, James Smith, W. J. Gallagher, W. I. Macomber, Frank

Bonnett, P. W. Hatch, Ben Wyman, F. H. Hennessey, Sigmond Fischer, W. L. Brewer, E.

Shepard, E. M. Slade, Eustace Crees, Samuel Kelly, C. S. Court, Edwin C. Bliss, D. B.

Nichols, C. Horton Whipple, George M. Baker, Jesse P. Eddy, B. A. Remington, E. R. Barker,

George W. Dove, William Bent, Walter W. Cobb, Frank Esser, H. E. Brown, Frank W. Bodesell,

H. Daggett, J. S. Hubbard, A. E. Henry, W. L. Ryder, William G. Payton, William Wild

Cratt, J. A. Fowler, F. H. Bliss, F. W. Young, Albert A. Remington, Horace E. Remington, John

Straight, Christopher W. O'Brien, E. L. Rogee, Fred P. Scott, P. H. Conley, J. W. Si-

mond, Wm. A. Cook, Frank Fontneau, Bertran Lenzer, E. A. Eddy, C. W. Brown, L. Lyons, E. C. Baker, William B. Streeter, A. Silverman, M. F. Williams, Fred J. Mills.

Echoes of the Banquet Hall.

George Dover circulated a lot and met many. Business or pleasure, George?

George Holmes was Frank Reynolds' balance wheel and helped to balance a lot.

J. Parker Ford makes an impressive appearance when he's "dressed up," doesn't he?

Frank P. Bonnett is a striking example in perfection of the type of the "seen and not heard" variety.

M. J. Baer wasn't noticeable except in the undivided, respectful and unusual attention he gave the several speakers.

Many of the jewelers ascended to the galleries when the speeches began, and the main floor lost several of its Apollos and Beau Brummels.

E. I. Rogers was busily engaged living up to his position of watching the bottles, corked and empty. But who kicked them over in spite of his watchful eye?

L. H. Carpenter took a special delight in hindering the work of several of the members of the press, and thereby obtaining the right to find his name in print.

F. V. Kennon was busily engaged collecting neglected souvenir sample cases and his search was successful. Isn't there a law against the practice?

Joseph and E. A. Coddling hurriedly left the hall in order to catch a suburban car. Though they didn't remain to circulate, they were in evidence while there.

Henry Wolcott's friends were disappointed that he hadn't an opportunity to address the entire audience, but he was heard from before the evening was over.

There was some posing attempted and accomplished when it was announced that a photograph was to be taken. R. C. Thompson looks very well in the picture.

George Cahoon couldn't stand even the thought of the night's festivities, so during the day prepared himself for his physician's care instead of the association's.

Frank Reynolds had a lot to do and grew somewhat excited perhaps when seats were few and late arrivals many, but we can say authoritatively, he never grew rattled.

W. H. Saart, immediately upon his arrival, began a diligent search for G. J. Kelley. Something is always visibly lacking whenever the one is in evidence without the other.

S. D. Macpherson and A. W. Roubaud, newly associated, were apparently not uninitiated in banqueting, and there were no hitches in anything they did that was noticeable.

R. J. Shoemaker sought information as to whether every concern represented had selected its most handsome member as a delegate. Shoemaker was there, that answers it.

Dr. Scott began his remarks to the tune of "We Won't Go Home Until Morning." Judging from the appreciation and applause given him, many could have listened even longer than that.

Wm. A. Cook impressed his companions (as he always does) with his usual sound business arguments. Frank Fontneau tried to suppress him, but "you can't keep a good man down."

The Hon. Wm. A. Morse discussed draw poker, the "kitty" and other technical terms that caused Harry Mays to frown—others laughed. Easy to tell a loser, or is Harry the only enthusiastic reformer perhaps?

The Hon. Henry Thresher, jeweler, esteemed

citizen and good fellow, also poet-laureate of the association, introduced Dr. Scott in an apt poetic way, but the doctor claimed the credit of authorship, though we don't believe it.

J. Otis tried to follow the mathematical trend of Senator Blackburne's discourse, but the effort proved too much. He explained his action by stating that he had only endeavored to add a little excitement to the occasion. He did.

Mr. Thresher gazed proudly from time to time at the immense sample case upon the platform just above the speakers' table, which measured five feet in height by three and one-half feet wide, and was presented by the Reuckert Mfg. Co. for the occasion. This "celebrated case" wasn't a rival, but a reminder.

Assets and Liabilities of Eisler & Laubheim as Shown by Bankruptcy Schedules.

Schedules in bankruptcy of Eisler & Laubheim, formerly in business at 87 Maiden Lane, New York, were filed last week and show liabilities of \$264,605, of which \$109,863 are contingent for indorsements on notes of customers. The assets consist of stock, \$154,987; machinery, tools, etc., \$4,000; debts due on open account (nominal), \$39,324; real estate, \$7,510 in Brooklyn and Laurel Hill, L. I.; money on hand, \$96, and stock in two realty companies, \$4,000.

Among the unsecured creditors are the American Cuttlebone Co., \$122; Belais & Cohen, \$151; Bruhl Bros. & Henius Co., \$3,841; Blancard & Co., \$138; Joseph H. Fink & Co., \$31,000; Goodfriend Bros., \$157; Herpers Bros., \$168; Hold-On-Clutch Co., \$332; L. & M. Kahn & Co., \$20,079; Konijn, Frank & Shire, \$9,608; Albert Lorsch & Co., \$579; Marx & Winkler, \$299; Oppenheim & Straus, \$1,920; A. Suderov, \$137; Treibs Bros., \$225; Wolfsheim & Sachs, \$125; L. & M. Wollstein, \$4,825; Laubheim Bros., \$24,788; Austrian H. Daniel, 171 Broadway, \$3,600; E. Frank, \$1,500; Herman Crossman, \$2,530; Caroline Laubheim, \$2,310; L. & A. U. Zinke, \$4,074; Mark Weiss, \$1,000; Samuel D. Kein, \$900; Arnstein Bros. & Co., \$285; Kleinberg & Probst, \$900; H. S. Ely & Co., \$132; C. P. Goldsmith & Co., about \$1,397; L. Halpert, \$325; Chas. A. Becker & Co., \$479; Market & Fulton National Bank, on draft, \$1,636; Importers & Traders' National Bank, \$750; Eduard Van Dam, \$675; Travelers' Credit Indemnity Co., \$150; Van Gelder Bros., \$328; Wm. J. Tighe, \$2,000; C. P. Goldsmith & Co., \$28,830 (liability on notes disputed in toto); Louis Halpert \$500 (liability on notes disputed in toto).

A hearing in the matter of the settlement proposed by this firm was held Monday in the United States District Court at the Post Office building. The terms of the settlement accepted by a majority of the creditors call for a 50-cent composition, payable in notes endorsed by Laubheim Bros. The notes are for 12½ per cent. each and are due July 10, 1908; Jan. 10, 1909; July 10, 1909, and Jan. 10, 1910. This settlement was confirmed by the court.

G. F. Batten, Suffolk, Va., Feb. 10, filed a homestead deed in the clerk's office of Nansemond County, exempting property valued at \$1,995.50. This includes a house and lot, household goods, kitchen furniture and a stock of goods.

ADDISON W. WOODHULL, President.
FRANK K. HUFF, Vice-President.

GILBERT T. WOODHULL, Treasurer.
WILLIAM J. McQUILLIN, Secretary.

MOUNT & WOODHULL,

IMPORTERS OF

DIAMONDS,

OTHER PRECIOUS STONES,

PEARLS, ETC.

MAKERS OF

FINE
DIAMOND
JEWELRY.

26 Maiden Lane,

(Southwest Corner Nassau Street)

NEW YORK

EMERALDS, DIAMONDS AND PEARLS	CABLE ADDRESS: MILBAGG
BAGG, PERINE & CO.	
IMPORTERS	
452 FIFTH AVENUE, at 40th Street	
(Formerly at 21 MAIDEN LANE)	
NEW YORK	
TELEPHONE NUMBERS: 917-918 BRYANT	RUBIES AND SAPPHIRES

F. A. JEANNE

Star Rubies and Sapphires

5 Square de l'Opera

PARIS, FRANCE

Cable Address

"GEMFINDER"

Western Union Code

DIAMONDS

TRY
US ON

Lissauer & Company
IMPORTERS

52-54 MAIDEN LANE, NEW YORK

Tel. 4457 } Cort.
4458 }

JOHN M. RICHARD

2 MAIDEN LANE
Room 302, NEW YORK

American Pearls and Baroques

MATCHED PAIRS FOR EARRINGS

The Largest and Finest Assortment in the Market, Mounted and Unmounted.

Jewelers in Pittsburg and Vicinity Taking Precautions to Save Stock from Effects of the Annual Flood.

PITTSBURG, Pa., Feb. 15.—A disastrous flood has Pittsburg elutched in its grasp and the indications are that it will do great damage. Not to be caught as they were a year ago, those merchants who will be affected by the ravages of the water are making preparations for it, because the rivers are expected to reach a flood height of 30 feet by to-morrow night or Monday morning. It is believed that most of the stores along Penn Ave. will have water in their cellars, while those on Federal St., North Side, will suffer the same fate.

Word also comes to Pittsburg that some of the jewelers at the up-river towns, especially along the Allegheny, will also suffer because of the flood. The stage of water, however, will not be as high as it was last March, when the greatest flood in the history of Pittsburg caused a loss of about \$100,000 to jewelers in Pittsburg and the towns in the upper and lower valleys.

Those jewelers whose cellars will be inundated were busy to-day removing goods to places of safety. The flood is always especially severe in the Penn Ave. district, and a 30-foot stage of water brings it into the establishment of Heeren Bros. & Co. as well as the stores on the opposite side of the street. Plenty of warning has, however, been given and precaution is being taken.

Heavy rains falling on several feet of snow in this district and the mountain regions caused the flood.

Max Marcus, Chicago, Offers Creditors a Settlement at Forty Per Cent.

Chicago, Feb. 12.—Max Marcus, 92 State St., is in financial difficulties, and Mr. Marcus, finding himself unable to meet his obligations, has submitted through the Jewelers Board of Trade an offer to his creditors asking a settlement on the basis of 40 per cent. Of this 10 per cent, is to be paid May 15, 10 per cent, Sept. 15 and 20 per cent, Dec. 15. The first payment is to be in cash and the second and third to be by notes due on the dates named, without interest.

Mr. Marcus has made a statement in which he shows his indebtedness to aggregate \$16,275.95, and his assets to be worth, nominally \$14,211.85. His estimates of his assets are as follows: Merchandise on hand, \$6,635.49; accounts, good, \$5,639.62; accounts, bad, \$1,468.70; cash on hand, \$285.94; checks dated ahead, \$182.10. Deducting the bad accounts his assets are supposed to be worth about \$12,745.15.

A representative of the Jewelers Board of Trade has made an investigation of the case and has recommended that the offer be accepted, as it will be to the advantage of all the creditors. The board is asking all creditors to place their claims in the hands of the organization without delay in order that concerted action may be taken.

Mr. Marcus, who was formerly of Marcus, Valentine & Co., has been doing business alone under the firm style of Max Marcus & Co.

D. M. Grinnell, Valley City, N. Dak., has sold his interest in the jewelry business to H. S. Proctor and J. R. McIntyre, Jr., Casleton, N. Dak.

Retail Jewelers of Arkansas Hold Adjourned Annual Meeting at Little Rock.

LITTLE ROCK, Ark., Feb. 12.—Jewelers from all parts of the State gathered here yesterday morning to participate in the annual meeting of the Retail Jewelers' Association, which was, in fact, an adjourned session of the meeting held last August, when the association was formed; at that time the organization included but nine members, while at the conclusion of yesterday's meeting it had reached 50. The proceedings occupied all of Tuesday and yesterday, and then adjournment was taken until Aug. 25, 26 and 27, when the jewelers will convene at Hot Springs.

The meeting began at Hotel Marion, the session being held in the banquet room. The presiding officer was the president, W. C. Short, of Prescott, and a good part of the first morning's work was consumed in routine business. Herbert Duval, secretary to Mayor Lenon, welcomed the delegates in behalf of the city and metaphorically extended to them the keys of the city, and addresses were made by a number of men in the jewelry trade, among the best being that of H. C. Carpenter, of the South Bend Watch Co., South Bend, Ind., who in the course of his remarks took occasion to say a few words against the drinking habit in all lines of business, saying that the treating habit for the purpose of making customers had practically passed away.

Other important addresses were delivered yesterday by A. P. Shattuck, who talked on the advantages obtained by organization and what jewelers could do by acting in a body, and President Short, who gave the history of the organization and how it had grown. W. Johnson, the secretary, also made an enthusiastic address.

The exhibits were especially pleasing, and resolution was passed asking the secretary to invite all who had sent representatives to find the same men to the convention when it meets at Hot Springs.

C. S. Stüft, of this city, who is one of the owners of the only diamond mines in the United States, delivered an interesting talk on diamonds and exhibited a number of gems from the Pike County mine. Another interesting talk was that of C. M. Lemmon, of the Illinois Watch Co., while the remarks of J. H. Purdy and other representatives were especially enjoyed. M. H. Johnson, of Winn, the oldest jeweler in the State who has been in business for 65 years, was also called upon for a few remarks.

It was ordered that the by-laws and constitution be printed and furnished to all members, and that \$5 per month be paid to the secretary to defray expenses.

President Short was instructed to appoint a committee to arrange for a uniform basis of prices for repairing which the committee to report at the Hot Springs convention. It was decided to adopt an association trade-mark for goods handled by the members.

Among other business a vote of thanks was extended to the management of the Hotel Marion for the use of the hall, which had been offered to the association without cost.

The meeting adjourned to-day amid much enthusiasm.

One of the chief features of the convention was the exhibits made by various manufacturers. These were in a suite on the second floor of the hotel, and included exhibits of the W. & S. Blackinton Co., Attleboro, Mass.; South Bend Watch Co., South Bend, Ind.; Heintz Bros., Buffalo, N. Y.; C. A. Kiger Co., Kansas City, Mo.; Illinois Watch Case Co., Elgin, Ill.; Elgin National Watch Co., Elgin, Ill.; Rockford Silver Plate Co., Rockford, Ill.; S. O. Bigney & Co., Attleboro, Mass.; Eisenstadt Mfg. Co., St. Louis, Mo.; F. H. Hardy & Co., Chicago, and Benj. Allen & Co., Chicago, and others.

Examination in the Bankruptcy of Joseph Brown & Co. Begins at Chicago.

CHICAGO, Feb. 13.—An examination of Joseph Brown, of Joseph Brown & Co., bankrupts, took place last Monday and Tuesday. Attorney Jacob Ringer, of Ringer, Wilhartz & Louer, represented the receiver; Hugo Pau represented the bankrupts.

According to Mr. Brown, he knew nothing whatever about the financial affairs of Joseph Brown & Co., but left it all to his office force. He stated he knew nothing whatever about either his resources or his liabilities. He said all transactions would be shown by the books of the corporation.

When questioned by Mr. Ringer why the Continental National Bank was paid \$5,000 before it was due, Mr. Brown said the bank asked to have all its accounts settled before making any more loans. Mr. Brown testified he had received as a loan \$2,000 from Ben Roth and \$5,000 from S. M. Jess, for which he gave as security merchandise for double the value of the loan. Both of these people have since been enjoined by the court from disposing of this property. Mr. Brown also testified that he had paid a lawyer named Raphael \$1,250 for four weeks' work in helping him run the office. This was thought good pay.

J. H. Glick, the bookkeeper, when called to the stand, said that the management had not taken stock this year, as they were too busy. He thought the stock would inventory \$110,000 and that the outstanding accounts were about \$40,000. He said that on Jan. 1 the corporation owed \$99,000 for merchandise and \$63,000 bills payable. The present estimate of the liabilities is \$175,000. In 1907 it was claimed the concern made \$18,000.

In a statement to the Jewelers Board of Trade it was claimed that in June, 1907, the corporation had assets of \$172,000 and liabilities of \$78,000.

The examination continues next week. In the meantime, R. H. Ingersoll & Bro. are petitioning the court for the return of \$500 worth of watches delivered Feb. 5, and A. & J. Plaut are petitioning the court for the return of \$1,500 merchandise delivered Jan. 25.

Norris McHenry, of McHenry & Stevens, Zanesville, O., left last week on a three weeks' trip through the south. Mr. McHenry went first to St. Louis and will proceed thence to Houston, Tex.

Industrial School Committee of North Attleboro Reports Against Project to Establish a School for Jewelry Workers.

NORTH ATTLEBORO, Feb. 15.—As forecasted in the last issue of THE CIRCULAR-WEEKLY the Industrial School Committee appointed by the citizens of North Attleboro last March to investigate into the feasibility of establishing an industrial school for jewelry reported against any progressive steps this Spring. The report submitted by Secretary Fred A. Howard reads as follows: "The committee on the question of industrial education, after several consultations with the State board, and having made a careful study of local conditions, reports that the development of the present evening drawing classes under the jurisdiction of the public school board, is the most feasible solution of the question under the present circumstances."

The drawing and design classes in the evening schools were very popular with jewelry workers, and sufficient good was accomplished to warrant the continuance for two weeks longer than anticipated. It is believed that the work continued in this manner will lead to a more elaborate school.

The annual report of the State Industrial Commission was given the past week to Governor Guild. An abstract says that "the work of establishing schools has proceeded along two lines, the establishment of independent day schools and independent evening schools. The greatest progress has been made in providing evening schools. It has been found that the ambitious among the employed realize not only the benefit of such schools, but eagerly seek the opportunities they offer, and in several instances have petitioned the local authorities to establish such schools."

Jewelers of the Attleboros Organize a New National Bank.

NORTH ATTLEBORO, Feb. 15.—Active steps were taken at a meeting, Thursday evening, toward the creation of a new National Bank for North Attleboro. Men prominent in the old Jewelers' Bank will back the new institution. It has been decided to place the capital stock at \$100,000 and to have a surplus of \$25,000. Shares will be sold at \$125. Over one-half of the stock has already been subscribed.

Frederick E. Sturdy, of the J. F. Sturdy's Sons, has consented to become president of the institution after considerable pressure was brought to bear. Mr. Sturdy is a strong, safe, conservative business man and will assist materially in making the new bank a strong institution. The directorate will consist of seven and will include: Frederick E. Sturdy, Joseph L. Sweet, of the R. F. Simmons Co., Attleboro; George K. Webster, Albert Totten, Andrew E. Jencks, treasurer of Slater Trust Co., of Pawtucket; G. Herbert French, of Riley & French; F. L. Baker, of the Paye & Baker Mfg. Co., and Fred. A. Howard.

The name of the new bank has not been selected, but it is very probable that the word "Jewelers" will be utilized in some manner. "The Manufacturing Jewelers and Silversmiths National Bank" has been suggested, but the only obstacle is that the title is rather cumbersome.

WM. S. HEDGES & CO.,

IMPORTERS AND CUTTERS OF

DIAMONDS.

Precious Stones and Pearls.

170 Broadway, Corner Maiden Lane, New York.

27 Holborn Viaduct, London.

R. C. SAUNDERS, Pres.

W. V. LAURINO, Vice-Pres.

JOSEPH P. MEURER, Treas.

SAUNDERS, MEURER & CO.

CUTTERS AND IMPORTERS OF **DIAMONDS** AND OTHER **PRECIOUS STONES**

FINE PEARLS AND FANCY GEMS

65 Nassau St., Cor. John St., Prescott Building Telephone, 1613 Cortland New York

Goodfriend Bros.

IMPORTERS OF **PEARLS**

Sapphires
Rubies
Opals
Emeralds

Aquamarines
Peridot
Gem Coral
Tourmalines

and OTHER
Precious and Imitation Stones

PEARL-OPAL-CORAL
& AGATE NECKLACES

PARIS:
10 Rue Cadet.

PROVIDENCE:
212 Union St.

9-11-13
Maiden Lane
NEW YORK

Geo. Brunswick, N.Y.

Max Schucht, Milwaukee, Wis., Files Bankruptcy Petition When Creditors Refuse to Settle.

MILWAUKEE, Wis., Feb. 15.—Max Schucht, doing business at 1509 Vliet St., has filed a voluntary petition in bankruptcy, and the schedules show assets and liabilities to be about \$14,000. The petition was not a surprise, as Schucht has been in financial difficulties for some time, and a short time ago made an offer to his creditors of 50 per cent. in full settlement. This was to be in cash and was based on his statement that his assets amounted to \$15,000, with real estate worth \$4,000, mortgaged for \$2,400, his liabilities being about \$14,000.

The attorneys for the Board of Trade, New York, investigated the offer thoroughly and recommended its acceptance, but several of the creditors refused, and this resulted in the bankruptcy petition being filed.

Mr. Schucht commenced business on his own account about 1896, when he bought out the assignee's stock of Jos S. Schaeffer. He had a well-established business and an excellent repair trade, employing three watchmakers.

Opening of Annual Convention of Indiana Retail Jewelers' Association.

INDIANAPOLIS, Ind., Feb. 18.—Members of the Indiana Retail Jewelers' Association convened for their annual meeting at the Claypool Hotel, in this city, to-day and will be in session to-morrow. At yesterday morning's meeting President C. Z. Rowe, of Argos, delivered his annual address.

In the afternoon Ralph M. Clark, of Anderson, president of the Indiana Retail Merchants' Association, gave a very entertaining talk, followed at night by an extensive address on "Salesmanship," by A. F. Sheldon, of Chicago. An address on "Organization and Its Results," by S. R. Miles, president of the National Retail Hardware Association, the reports of committees and the election of officers were scheduled for to-morrow.

Games Rolled by the Jewelers' Bowling League of New York.

The following were the scores of the teams of the Jewelers' Bowling League in the games rolled last week:

Feb. 13.—Jos. Fahys & Co.....	857	886	74
vs. N. H. White & Co.....	831	854	80
Feb. 14.—Cross & Bequelin.....	880	890	90
vs. Tiffany & Co.....	820	871	52

STANDING OF THE TEAMS.

	Won.	Lost.	High score.	Pct.
Cross & Bequelin.....	32	13	1,017	.71
N. H. White & Co.....	32	13	1,014	.71
Cooper Diamond Co.....	31	14	1,022	.69
C. F. Wood & Co.....	24	12	943	.66
Tiffany & Co.....	27	18	969	.60
Jos. Fahys & Co.....	25	23	906	.52
Nikin-Lambert Co.....	23	22	967	.51
A. A. Webster & Co.....	16	29	916	.35
H. W. Wheeler & Co.....	10	26	922	.27
Julius King Optical Co.....	10	35	889	.22
L. E. Waterman Co.....	7	32	852	.18

A youthful and well-dressed thief secured a diamond ring from a tray at the store of E. D. Oliver, Burlington, Pa., about a week ago and darted from the store with it. The jeweler pursued the thief, who threw the ring back into the store and finally escaped on a trolley car.



C. M. Sageser has engaged in business at Philip, S. Dak.

Wm. Shields has opened a repair shop at Pilot Rock, Ore.

C. E. Huett has begun business in Woonsocket, S. Dak., as a retail jeweler.

C. E. Henderson recently opened a store at 52 Patton Ave., Asheville, N. C.

The Bay State Jewelry Co. is a new concern at 175 Broadway, Lawrence, Mass.

Alex. Nelson will soon open a jewelry store in the Triplett building in Enderlin, N. Dak.

Kahan & Bernstein will start in business this week as jobbers at 51 Maiden Lane, New York.

J. C. Bates has again opened a store at Haverhill, Mass. The store is located at 1 Railroad Sq.

A. H. Ferris, formerly employed by W. E. Lee, Corning, Ia., will shortly engage in business on his own account at Winfield, Ia.

Chas. W. Nebel, who had been associated with A. Reinhard for several years, has opened optical parlors at 495 12th St., Milwaukee, Wis.

Cornelius Caddel, until recently employed by F. W. Swan, Muscatine, Ia., will open a new store for himself April 1, at 109 W. 2d St., that city.

Wm. H. Safford, Jr., has opened an optical store in connection with his father's jewelry establishment at 6 Pleasant St., Newburyport, Mass.

Fred. Bender has gone into business on his own account at Rowland St., Detroit, Mich. The new firm is known as the Detroit Jewelry Mfg. Co.

John A. Hornik has purchased the bankrupt stock of Wm. Ulrich from the Bonfield Jewelry Co., and will start in business at 322 Gratiot Ave., Detroit, Mich.

Jas. Gilles is about to open a repair shop at 512 Altman building, Kansas City, Mo., where he will do repairing for the trade. He will have a partner in the business.

The Crescent Jewelry Co. has filed articles of incorporation in Ogden, Utah. J. S. Zeller is president of the concern. The store will be located on Washington Ave.

New firms at Haverhill, Mass., are: A. Frisch, 153 Washington St.; G. A. Keen, 47 Merrimac St.; Victor Jewelry Co., 11 Emerson St.; W. C. Smith, optician, at 11 Emerson St.

J. S. Chapman recently began business as a jewelry engraver, on E. Norwegian St., Pottsville, Pa. Mr. Chapman was formerly in the employ of W. H. Mortimer, of the same place.

Edward J. Johnson, formerly with the Washburn Jewelry Co., Anderson, Ind., has rented quarters in the Union building, at that place, where he will shortly begin business on his own account.

Joseph H. Miller, for the past 20 years superintendent of M. W. Carr & Co., Som-

erville, Mass., has severed his connections with the firm and left for Chicago, where he will engage in the manufacture of jewelry.

Emil Haeni opened his new watch, clock and jewelry store at Freeport, Ill., last week. Mr. Haeni, who formerly worked in the vicinity of Freeport as a watchmaker, has for the last few years traveled for the Rockford Watch Co.

The Delamothe Natural Art Decorating Co. is the name of a concern which was recently incorporated in Spokane, Wash., with a capital stock of \$25,000, to manufacture a unique line of jewelry. Among those interested are: J. A. Borden, E. J. Hyde, A. M. Dewey and A. S. Oliver.

Association Notes.

I. M. Radabaugh, secretary of the American National Jewelers' Association, is sending out to the members and press the report of the harmonious and enthusiastic meeting held recently by the executive committee at Cincinnati (reported in full in THE CIRCULAR-WEEKLY, Feb. 5), telling of the royal entertainment of the committee by the jobbers and retailers of that city. The dates for the annual convention were fixed for Aug. 4, 5, 6 and 7, which is the first week preceding the annual meeting of the American Association of Opticians, in Philadelphia. The programme for the coming meeting was outlined as follows:

- Monday evening—President's reception.
- Tuesday morning—Regular business.
- Tuesday afternoon—Department of manufacturing. In this connection it is expected to have representatives of different classes of manufactures connected with the jewelry business to demonstrate their processes of manufacture.
- Tuesday evening, 7:30—An illustrated lecture by Mr. Duncan, of the Waltham Watch Co.
- Wednesday morning—Regular business.
- Wednesday afternoon and evening open for entertainment and sightseeing.
- Thursday—Business and addresses.
- Friday morning—Election of officers, business and adjournment.
- Friday afternoon and evening—Entertainment and sightseeing.

The full programme will be announced at an early date. Secretary Radabaugh calls particular attention to the resolutions of the committee in favor of an amendment to the National Stamping Law, forbidding the use of the words "gold" or "solid gold" on an article unless it shall be at least 10 karats fine, and asks the support to this amendment both for the national and State laws from all members of the association.

Max J. Egge, secretary and treasurer of the Nebraska Retail Jewelers' Association, is sending out notices to members to be sure and attend the second annual meeting, which is to be held in Lincoln, Feb. 27, in the Assembly room of the Lincoln Hotel. The meeting follows that of the State Optical Society, and will be preceded, Wednesday evening, by a theater party, in which the members of the optical society as well as the jewelers and their wives will participate. The programme is as follows:

- Morning Session.**
- Reception and registration—Meeting called to order at 9:30 A. M.
- Address by the president, J. A. Rueling, Wymore.
- Report of secretary and treasurer, Max J. Egge, Grand Island.
- Report on National Association meeting at Chicago. T. L. Combs, Omaha.

"Benefits of Organization." Mack A. Hurlbut, Fort Dodge, Ia., president of the National Retail Jewelers' Association.

"The Jewelry Business 25 Years Ago." George Arkright, Beatrice.

Afternoon Session.

Meeting of executive committee at 1:30 P. M.—Meeting called to order at 2 P. M.

"Initiative vs. Defensive Methods in Business." M. D. Franks, Omaha.

Discourse. Mr. Higginbotham, of the South Bend Watch Co.

"The Jeweler's Guarantee." Discussion led by Fritz Hoefler, Aurora.

"Side Lines That Pay." Discussion led by Max J. Egge, Grand Island.

New business.
Election of officers for ensuing year.

The Alabama Retail Jewelers' Association will meet in Mobile in annual session Friday, Feb. 28. The association, which is entering its third year, met in 1906 at Birmingham, and last year in Montgomery, when an invitation tendered by the Mobile delegation, through H. Gabriel, to meet at Mobile in 1908, was referred to the executive committee and later accepted.

The president and directors of the Mobile Commercial Club have tendered the use of the club rooms for the meeting. The present membership of the association numbers about 40. A majority of these, with their families, will be present, as the meeting is concurrent with the carnival festivities.

Death of Henry Grant.

TORONTO, Can., Feb. 15.—Henry Grant, a prominent jeweler of Montreal, died in that city, on Thursday, at the age of 89 years, after a long illness. Mr. Grant was an Englishman by birth, but had been a resident of Montreal for 47 years.

In early life Mr. Grant was manager for the Emanuels, of Portsmouth, Eng., court jewelers and makers to the Admiralty, and was brought into contact a great deal with members of the court and the royal family. He afterwards conducted an extensive mathematical optical and nautical instrument establishment at Cardiff, where he controlled the nautical business of the port, constructing for that purpose a complete time observatory, using a transit instrument specially made for the late Admiral Fitzroy. This instrument he brought with him to Canada, and it is now in use at McGill University.

Mr. Grant was a prominent Free Mason and has held many important offices in the order. He was a talented musician and of a jovial and congenial nature.

Market Price for Silver Bars.

The following are the quotations of silver bars in London and New York, as reported by Zimmermann & Forshay:

	London.	New York.
Feb. 11.....	26 3-16d.	.999 Basis. \$58 3/4
" 12 (Holiday).....
" 13.....	26 1-2d.	.59 1/4
" 14.....	26 5-16d.	.59
" 15.....	25 13-16d.	.57 3/4
" 17.....	25 15-16d.	.58 1/4

Louis E. Fornes, Canton, O., has assigned. George Eckert, Jeannette, Pa., will occupy one of the two new office buildings which are being erected at that place. He expects to be able to move into the new quarters about March 15.

EICHBERG & CO.,

IMPORTERS AND CUTTERS OF

DIAMONDS,

65 NASSAU STREET, (Prescott Building.) NEW YORK.

"There is Nothing in the Art that we cannot do."

Special Attention

GIVEN TO OUT OF TOWN ORDERS

The International Gem Co., Inc.

12-16 JOHN ST., NEW YORK

TELEPHONE 1241 GORTLAND

Lapidaries and Importers of Precious Stones

SPECIALISTS IN REPAIRING AND REPOLISHING RARE AND VALUABLE GEMS
DRILLING—ENGRAVING—SLITTING

A. ROSEMAN, 9-11-13 Maiden Lane, New York

IMPORTER OF

DIAMONDS

Maker of Diamond Jewelry



TRADE-MARK.

Established 1872

HEADQUARTERS FOR

AMERICAN WATCHES

HIMALAYA MINING COMPANY

MINERS AND CUTTERS OF

PRECIOUS AND SEMI-PRECIOUS STONES

537 FIFTH AVENUE

NEW YORK

LONDON
PARIS

OBERSTEIN
PROVIDENCE

VARASITE SOHN & HYMAN

Sole Agents

47-49 MAIDEN LANE
NEW YORK

The Newest Stone for High Class Jewelry

LOUIS FELDENHEIMER

Importer and Cutter of

PRECIOUS STONES AND PEARLS

41 MAIDEN LANE

NEW YORK

JOHN AUSTIN & SON

Assayers, Refiners and Smelters

74 & 76 Clifford Street PROVIDENCE, R. I.

We Do Our Own Smelting.



Isidor Guntzberger Gives a Deed of Trust and Business Is Continued by the Trustees.

Acting on the suggestion of his creditors, and in order to conserve his assets for the best interests of all concerned, Isidor Guntzberger, of Isidor Guntzberger & Son, 11 John St., New York, has turned his business over to three trustees, and the deed of trust, assented to by the creditors, was filed in the county clerk's office at New York last week. This deed as recorded is spoken of as an assignment, but is not exactly an assignment under the New York laws, though it affords to some extent the protection that an assignment would give.

The action was taken as a result of the meeting of the creditors held Jan. 13, at which Mr. Guntzberger explained the condition of his business, showing that the assets were largely in excess of his liabilities and that, though in no way insolvent, it was necessary to preserve the value of the assets by continuing the business as a going concern under the direction of the creditors. The deed of trust was taken in preference to an extension, and the business will be conducted by the trustees who have authority to continue it, buy goods and pay off the debts within two years.

The trustees who have the business in charge are Samuel Arnstein, Oscar Jonassohn and Henry E. Oppenheimer. They are authorized to carry on the business, collect outstanding accounts and pay all creditors.

In speaking of the matter to a CIRCULAR-WEEKLY reporter, Henry E. Oppenheimer said that I. Guntzberger & Son are entirely solvent and could have easily carried over their present troubles. He said that the assets were twice the amount of liabilities, and that it was regrettable that the matter had to be given publicity. He placed the assets at about \$200,000, with liabilities of about \$100,000. He stated that the creditors had arranged to carry the firm over the present trouble, and would have done so without going to the courts had it not been for one creditor who declined to sign an agreement to this effect unless it was understood that he was to get all of his money at once.

The papers as filed at the county clerk's office give the trustees the right to pay off creditors 10 per cent. at a time, as the assets are realized on, and it is understood that the business will be turned back to the firm as a going business as soon as the claims are liquidated.

Mr. Guntzberger has been identified with the trade for 30 years. He started the present business in 1901, and in January, 1907, admitted his son. Many of the creditors are European firms. The trouble is attributed to the dull business in the past few months and the inability to collect outstanding accounts.

Assets and Liabilities of Louis Halpert as Shown by His Schedules in Bankruptcy.

Schedules in bankruptcy of Louis Halpert, 51 Maiden Lane, New York, against whom a petition in involuntary bankruptcy was filed in January, were filed in the United States District Court, New York, Monday, showing liabilities of \$24,641.56 and assets of \$14,735.58. The latter consists of cash, \$90; notes, \$1,537; goods on in-

section, \$843; merchandise on hand, \$3,077; office fixtures, \$215, and accounts, \$,008.

Among the unsecured creditors are: D.essler, \$1,378; Isaac Blumberg, \$500; Goldsmitz Bros., \$383; Eisler & Laubheim, \$290; W. Czosnek, \$413; D. Teicher, \$421; B. H. Davis, \$813; R. A. Breidenich, \$1,305; H. Dietz, \$310; S. Hess, \$100; Glas & Fisher, \$178; N. Salter, \$809; R. Blatt, \$250; notes held by Mercantile National Bank, \$1,122; notes held by David Teicher, \$388; accommodation paper delivered to Eisler & Laubheim aggregating about \$11,070.

Mr. Halpert began business at 65 Nassau St., New York, in 1898, and in 1900 removed to Maiden Lane.

Members Elected and Rewards Paid by the Jewelers Security Alliance.

At the regular monthly meeting of the Executive Committee of the Jewelers Security Alliance, held last Friday, the dividend of \$100 was ordered paid to Fire Chief C. M. Arthur and Firemen S. B. Smith and Fred Ducomb, of Findlay, O., for the arrest and conviction of J. C. Moran and Joseph Laboon, who broke into the show window of George R. Thomson, of that city, and stole a tray of diamonds amounting to about \$5,000 in value. When Mr. Thomson attempted to prevent the robbery, he was attacked and beaten upon the head with revolvers and seriously wounded. The three firemen heard the disturbance and the outcry of the persons following the robbers, and, at the risk of their lives, succeeded in capturing them and securing nearly all of the stolen goods. The two robbers were sentenced to 11 years in the penitentiary, and are now serving time. The following new members were admitted to the Alliance:

N. Crocker, Rock Springs, Wyo.; Starr C. Swift, Salem, Mass.; C. M. Howard, Boston, Mass.; H. P. Nielsen, Lorain, O.; E. A. Odman, Irapaiso, Nebr.; Arthur De Montigny, Nashua, N. H.; Delmont E. Gordon, Hillsboro Bridge, N. C.; Daniel Low & Co., Salem, Mass.; Anna I. Vieira, San Francisco, Cal.; George S. Adams, Bastopool, Cal.; R. A. Esslinger, Hicksville, N. Y.; George W. Barbour, Portland, Me.; William Hunter & Co., Portland, Me.; Philip H. Kimball, Wburyport, Mass.; William H. Safford, Newburyport, Mass.; Elmer G. Worthley, Amesbury, Mass.; Gustave A. Schmidt, Lawrence, Mass.; J. C. McGovern, Haverhill, Mass.; Horace E. Beiss, Stoneham, Mass.; Smith & Varney, Woburn, Mass.; F. C. Dietrich, Point Richmond, Cal.; Alhewson-Pelz Jewelry Co., Marshall, Tex.; B. Egel, New York; Buhrman & Emery, Springfield, Mo.; Newman Brothers, Merkle, Tex.; Endicott Loan Co., Boston, Mass.; Mrs. A. M. Hill, Lynn, Mass.; Guy L. Millett, Brookline, Mass.; I. Pendleton & Sons, Boston, Mass.; O. J. Somers & Co., New York; George F. Draper, Danvers, Mass.; Eugene Laliberte, Nashua, N. H.; E. Malsberry, Rockwood, Pa.; S. E. Ruggles, Kenbunk, Me.; John C. Denniston, Dansville, N. Y.; A. W. Hayes, Dover, N. H.; Frederick Newland, East Hartford Meadow, Conn.; Horace G.udson, Amesbury, Mass.; C. M. Lane, Bernardsville, N. J.; George L. Whitehouse, Dover, N. H.; Albert G. Farnham, Lawrence, Mass.; A. W. Cassler, Malvern, Ark.; E. Y. Stinson, Benton, Ark.; F. Kimball & Son, Wakefield, Mass.; A. & Delovage, Portland, Ore.; Leon E. Gibson, Richford, Vt.; Schultz & Lapp, Newark, N. J.; John M. Roberts & Son Co., Pittsburg, Pa.; C. E. McKinlin, Chanute, Kans.

Emrich Matusky, Baltimore, Md., has sold out to Jacob Rubin. Leon R. Phillips will continue the business of the firm of Gibbs & Phillips, Grand Rapids, Mich., which recently dissolved.

BLACK OPALS

REMARKABLE :: IRIDESCENT :: BEAUTIFUL

Black Opal, a recent Australian discovery, is one of the most beautiful stones hitherto found.

With it many inimitable jewelry creations are possible that must appeal in a forcetful manner to the trade.

These remarkable stones exhibit a wonderful play of brilliant colors, ranging from light to cobalt blue, with flashes of violet, from delicate shades of green to peacock green, and all shades of reds, merging into orange and yellow tints.

Black Opal is a worthy addition to the finest stock, and jewelers will find it a welcome "Trade Magnet."

We can furnish these stones in various sizes and shapes, and their full merits can only be appreciated by being seen.

We make a specialty of AUSTRALIAN and MEXICAN OPAL MATRIX.

BUY FROM THE CUTTERS

AMERICAN GEM & PEARL COMPANY

14 & 16 CHURCH STREET, NEW YORK

London, 16 Holborn Viaduct

Paris, 39 Rue de Chateaudun

FROM MINES TO MARKET

CORAL

All Kinds of Coral Specialties for Jewelers

DROPS
BUTTONS
LENTILLES

CORAL
NECK-
LACES

All Shades and Sizes

Uniform and Graded



CORAL

Extra Rose
CORAL
A Specialty

Gold Medal
St. Louis, 1904

Grand Prix
Liege, 1905

BORRELLI & VITELLI

3 Via Amedeo,
Terre del Greco Italy

401 Broadway, New York
Telephone, 5412 Franklin

19 Rue d'Hauteville,
Paris, France

ARTHUR REICHMAN

BUYS AND SELLS

AMERICAN BAROQUE PEARLS

65 Nassau St.

New York

GORHAM SILVER

¶ The unexampled variety and diversity of Gorham silver designed to serve as Prizes and Trophies, are such as must appeal to the jeweler called upon to meet the oft-times fastidious demands of club committees and others charged with the task of selection.

¶ Vases, Loving Cups, Tankards and Special Pieces of every description, from the simplest to the most elaborate, in every style and at every price. Such, indeed, as cannot fail to appeal to the most exacting taste, are always in stock.

¶ Nor is the range of selection confined even to these wide limits. The Gorham Company is always ready to forward at short notice attractive sketches of artistic designs specially prepared to meet individual demands.

THE GORHAM COMPANY,



CHICAGO,
137 Wabash Ave.

Silversmiths and Goldsmiths

Fifth Avenue and 36th Street, New York.

BRANCHES:

NEW YORK,
23 Maiden Lane.

SAN FRANCISCO,
Temporary Office:
1103 Broadway, Oakland, Cal.

LONDON,
Ely Place.



WORKS: Providence and New York.

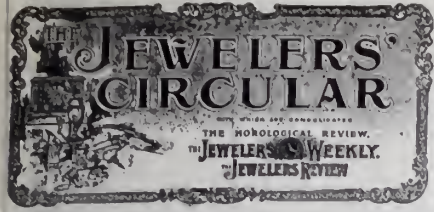

PUBLISHED EVERY WEDNESDAY BY

THE JEWELERS' CIRCULAR PUB'G CO.

J. Mulford, Pres. & Treas. V. S. Mulford, V. P. & Sec.

11 JOHN ST., COR BROADWAY, NEW YORK.

TELEPHONE:
148 CORTLANDT.

CABLE ADDRESS:
JEWELAR, NEW YORK.

VOL. LVI. FEBRUARY 19, 1908. No. 3.

Subscription in United States and Mexico, \$2.00
 Dominion of Canada, 3.00
 Other Countries in Postal Union, 6.00
 Single Copies, .10

Remit by check or money order. Remittances in money are at sender's risk.

Index to News and Special Articles.

	Page.
Landsoome Punch Set for United States Gunboat <i>Paducah</i> . Illustrated on front cover; text on.....	39
Miss Bee's Fashions.....	39
Development in the Art of Jewelry Making.....	11-15
List of Watches and Jewelry Recently Stolen From the Store of P. P. Davis.....	15
Officers Elected by Philadelphia Jewelers' Club. Jewelry, etc., Exported From New York.....	45
Pittsburg Jewelers Cause Arrest of Two Men Believed to Be Check Swindlers.....	47
Bankruptcy Proceedings Begun Against Frankfurt Loan Co., Norfolk, Va.....	47
To Change Name of Jewelers' League.....	49
Jewelry Salesman Accused of Stealing Stock Worth \$15,000, Brought to New York.....	49
Death of Christian Irion.....	49
Death of John Campbell.....	49
Boys Confess to Selling Silver Scrap and Spoons Stolen From Attleboro Firms.....	49
Bankruptcy Trustee Brings Suits to Determine Pawnbrokers' Rights to Articles Pledged by One Who Doesn't Own Them.....	51
Beware of This Man Whom Police Say is Offering Worthless Checks to Jewelers.....	51
Importations at the Port of New York.....	51
Winter Banquet of the New England Manufacturing Jewelers and Silversmiths' Association.....	52-55
Sisler & Laubheim File Schedules.....	55
Pittsburg Jewelers Prepare for Flood.....	56
Max Marcus Offers 40 Per Cent. Settlement.....	56
Retail Jewelers of Arkansas Hold Annual Meeting at Little Rock.....	57
Examination in the Bankruptcy of Joseph Brown & Co. Begins at Chicago.....	57
Industrial School Committee of North Attleboro Reports Against Project to Establish a School for Jewelry Workers.....	57
Jewelers of the Attleboros Organize a National Bank.....	57
Max Schucht, Milwaukee, Wis., Files Bankruptcy Petition.....	58
Annual Convention of Indiana Retail Jewelers' Association.....	58
Games Rolled by Jewelers' Bowling League.....	58
New Enterprises.....	59
Association Notes.....	59
Death of Henry Grant.....	59
Isidore Guntzberger Gives a Deed of Trust.....	60
Assets and Liabilities of Louis Halpert as Shown by His Schedules in Bankruptcy.....	60
Members Elected and Rewards Paid by the Jewelers' Security Alliance.....	61
Gold Bars Exchanged for Gold Coin.....	63
Short Change Swindler Gets Diamonds From Louisville, Ky., Jeweler.....	69
Death of Joseph Bachman.....	69
A Catechism of the Lever Escapement—(Continued).....	87-91
The Dial.....	91
How to Meet the Competition of the Mail Order House—(Continued).....	96
An Attractively Designed Advertisement.....	96
The Man of the Hour in Business.....	97
A Representative Retail Jewelry Store of New England.....	97
Heavy Spring Buying and Extensive Advertising the Harbingers of Renewed Prosperity.....	98
A Simple Method of Depositing Metal Upon Glass, Wood, etc.....	101
Smyrna Umbrella Imports.....	103
The White House China Collection.....	105
A Candid Confession From a Retired "Near Diamond" Merchant.....	107

FROM the way that the articles that have been appearing in THE CIRCULAR-WEEKLY have been reprinted in trade and technical journals, as well as in the daily newspapers, it would seem that our efforts to obtain original matter for our readers are appreciated even outside of the trade itself. As we have often said that unless an article has been especially copyrighted we are happy to have any matter that appears in THE CIRCULAR-WEEKLY used by our subscribers or exchanges, but simply ask that credit be given to the source from which it is obtained. Unfortunately in several instances recently reputable papers have copied articles from THE CIRCULAR-WEEKLY and published them without credit, practically offering them to their readers as original contributions, which is not only a species of fraud as far as their readers are concerned, but also does an injustice to us. In some instances the omission of credit may have been an oversight, but in others it has been done so often as to appear deliberate. If such acts occur in the future we may be forced to protect our rights, but we think that a little reflection on the part of the offending publishers will convince them that it will pay them, when taking articles and illustrations from this journal, to give the credit that the common courtesy of the newspaper profession demands.

IN another column of this issue will be found the first instalment of a report of a lecture by Mrs. W. S. Hadaway before the Applied Art Section of the Society of Arts, London, and though much that she touches upon is of more interest to British than American jewelers and exception may be taken to some of her statements, where she speaks of individual craftsmen, nevertheless a considerable amount of valuable information can be found that will interest American manufacturers who wish to keep abreast of the development of the art side of their craft. Mrs. Hadaway is the wife of an American artist who came to England to study enameling at the Central School of Arts and Crafts, and with her husband has been making a name among the arts craftsmen of England. While her discussion of commercial productions shows a lack of professional knowledge which will be appreciated by the manufacturers, nevertheless her comments and statements on the artistic side of the subject have in them much of value. All things considered, the lecture has many good points, and the fact that it was given at the instigation of a famous society makes it worthy of serious consideration, and we offer it to the jewelry trade of this country for what it is worth. The lecture will be completed in the issue of March 4.

Promoting Diamond Mines Through the Press.

FROM a number of newspaper extracts that have been received at this office in the past few weeks it would seem that a determined effort is being made on the part of certain people to interest the public in diamond mines of Brazil and Mexico and other parts of the world, as press dispatches, some dated from New York and some dated from other parts of the coun-

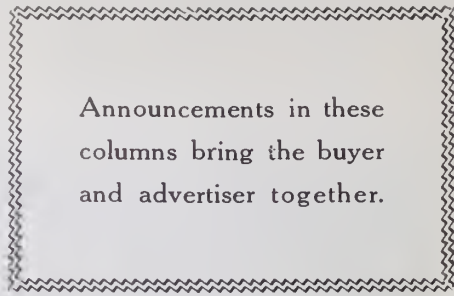

Announcements in these columns bring the buyer and advertiser together.

try, have been sent to papers in various sections, calling attention to new mines, speaking in glowing terms of their prospects, etc., without directly stating there was an opportunity for investors to buy stock. However, this will probably come later in the way of advertisements in the financial columns. One series of dispatches, which pretended to emanate from New York, spoke of Brazilian mines, and even went so far as to say that there was a "slump" in the diamond market caused by the fact that these Brazilian mines were about to operate.

As jewelers are often approached personally on stock jobbing schemes of this kind, and are often consulted by customers on the merits of such propositions, it behooves all to bear in mind that the ways of the stock promoter and his press agents, like those of "the heathen Chinee," are peculiar and also clever; that newspapers are often misled into publishing as items of news stories that are nothing more than fabrications of press agents for the purpose of interesting the public in stock market propositions and sowing seed that will make the subsequent direct work, in the way of sending prospectuses, fall upon fertile ground.

As far as the Brazilian propositions are concerned generally, it is well to call attention to the warning of an American Consul in that country recently to the effect that a large number of companies had been incorporated and concession obtained, not for the purpose of mining diamonds, but for the purpose of forming companies and making money from the public in the sale of the stocks thereof. This does not at all mean that there are not legitimate diamond companies in Brazil, but the fact that the legitimate companies are there gives the opportunity to the stock jobbing "faker" to carry on his work successfully.

The safest advice that the jeweler can take on the subject of buying stocks in diamond companies of which he knows nothing is to be summed up in the one word—"don't."

Jewelers' Gold Bars Withdrawn and Exchanged at New York.

Week Ended Feb. 15, 1908.

The U. S. Assay Office reports:

Gold bars exchanged for gold coin.....	\$213,872.56
Gold bars paid depositors.....	32,812.45
Total.....	\$246,685.01

Of this the gold bars exchanged for gold coin are reported as follows:

Feb. 10.....	\$57,408.63
" 11.....	26,515.79
" 13.....	83,443.97
" 14.....	35,918.91
" 15.....	10,585.26
Total.....	\$213,872.56

FIRST HANDS



CROSS & BEGUELIN

Importers and Cutters of Diamonds and Precious Stones

43 Rue de Meslay, PARIS

Telephone,
480 John

31 Maiden Lane, NEW YORK



**The
Silent
Appeal**

H.A. KIRBY

FINE
GOLD
JEWELRY

PROVIDENCE
NEW YORK

HAVE YOU EVER REFLECTED ON HOW A PRETTILY WROUGHT AND EFFECTIVELY DISPLAYED DESIGN WILL UNCONSCIOUSLY INFLUENCE A PURCHASE? HOW FIRST IT EXCITES ADMIRATION IN THE INDIFFERENT SPECTATOR, THEN IRRITATES THE DESIRE TO POSSESS, AND FINALLY BY ITS VERY IRRESISTIBILITY COMPELS HIM TO PURCHASE? IN EFFECTING SUCH A SALE, ONLY A FEW CONVENTIONAL REPRESENTATIONS ARE NECESSARY BY THE JEWELER, WHOSE PROFITS ARE A JUST REWARD FOR HIS SHREWDNESS IN EQUIPPING HIMSELF WITH SUCH JEWELRY. WE MAKE IT IN AN INEXHAUSTIBLE VARIETY—AT MODERATE COST.

Washington, D. C.

S. M. Selinger has just returned from a trip to New York. He reports business as being very good.

W. Breuninger, 929 Pennsylvania Ave. N. W., has been confined to his home by illness for the past month and is not improving as much as his friends would wish.

Several jewelers speak of the need of a first-class plater, engraver and enameler in this city. A good many orders are received for such work, all of which has to be sent to New York. This need is especially felt during the Winter seasons.

Gerome Desio, of the firm of Victor F. Desio & Co., has gone on a trip for his health, which will carry him practically over the south. He will spend a large part of the time in Palm Beach, Fla., and will also make a stop at Pinehurst, where the firm formerly had a large store, but which has been closed this year, as business conditions there are unusually quiet. While the trip is primarily for his health, Mr. Desio will give some attention to trade and financial conditions, as he passes from section to section of the country.

A. Brozlawski, manager of the Castler National Jewelry Co., in speaking of a note in the last issue of THE JEWELERS' CIRCULAR WEEKLY about the suit brought against the concern for an accounting on behalf of Robert Castler, said that Mr. Castler has received full payment for all outstanding accounts, and the only ones he could have possibly had some interest in were some "dead" ones that had been charged up to profit and loss. Mr. Brozlawski said further that no letter or authority had been received by any one from Mr. Castler since his disappearance, August, 1905.

Savannah, Ga.

R. Van Kuren & Co. and Theus & C. donated gifts to the Valentine party of the pupils of St. Vincent Academy, held in Savannah, Feb. 13 and 14.

A man supposed to be L. B. Sless, formerly of Philadelphia, called on E. Hochman, of 18 W. Broughton St., on Friday of last week, and selected a fountain pen for \$7, telling the jeweler that he would give a check, Saturday night, for his wages and would return then and buy the pen Saturday night. Sless called and presented a check on the Hibernian Bank, of Savannah, for \$76.48, payable to himself, and signed "The Commercial Lithographing and Printing Co.," by H. Waisberg. Mr. Hochman accepted the check, delivered the pen to Sless and paid him \$69.48 cash. On Monday the check was deposited by Mr. Hochman in the Citizens' and Southern Bank. When presented at the Hibernian Bank for payment it was at once discovered to be fraudulent. H. Waisberg, whose signature has been poorly imitated, was sent for and pronounced the check a forgery. He said Sless had been in the employ of his company for a short time as a solicitor, but had not been successful. He thought it probable he had left the city after securing the money. The police department was notified promptly when the forgery was discovered, but the forger has not been located having had ample time to leave the city.

New York Notes.

John Scheidig & Co., opticians, 50 Maiden Lane, will move, May 1, to 32 Maiden Lane.

Benjamin F. Rees, of Zimmern, Rees & Co., left yesterday for Europe on a diamond buying trip, sailing on the *Kronprinzessin Cecile*.

Kahan & Bernstein is the name of a new firm that will do a jobbing business in jewelry, diamonds, etc., at 51 Maiden Lane. The partners are Chas. Kahan and B. H. Bernstein, who expect to open their office the latter part of this week.

Frederick W. Rauch who was formerly with Kleinschmidt, Howland & Co., has started in the diamond, pearl and precious stone brokerage business for himself. He has his office with Kleinschmidt, Howland & Co., 170 Broadway, for the present.

Among those who have voiced their intention of closing their stores early on Saturday nights at Paterson are the Guarantee Jewelry Co., E. R. Vermeer and Mrs. Mary B. Cannon. The movement now being made is to close the stores by nine o'clock Saturday night.

Many of the residents of Greenwich Village have been inconvenienced recently by the condition of a clock in the tower of Jefferson Market, at Sixth Ave. and 10th St. Three of the clock faces in the tower are in perfect order, but the one facing south has been out of order for some time past.

Seth Edward Thomas, Jr., son of Mr. and Mrs. Seth E. Thomas, and Miss Josephine Frederika Van Beuren Reynolds, the daughter of Mrs. Emily A. Van Beuren Reynolds, of this city, will be married tomorrow. Mr. Thomas is the secretary and director of the Seth Thomas Clock Co., 51 Maiden Lane.

Creditors of Edwin W. Dayton, bankrupt, are notified that the first meeting of creditors will be held at the office of William Allen, referee in bankruptcy, 67 Wall St., Feb. 24, at 11:30 A. M., at which time creditors may prove their claims, appoint a trustee and transact such other business as may come before the meeting.

At the National Arts Club there is an exhibition a clever display of jewelry made by English craftsmen. Included in the lot is a silver and opal necklace by Violet Ramsey, while Mr. and Mrs. Arthur Gaskin have made a silver and enamel necklace, with opals, emeralds, pink tourmalines and opazes. Ethel P. Agnew, among many things, has a silver brooch, with enamel birds and opals.

At the regular monthly meeting of the directors of the Jewelers Board of Trade, held last Thursday, the following firms were unanimously elected to membership on the board: John F. Allen, Providence, R. I.; Arnold & Steere, Providence, R. I.; Harrington Mfg. Co., Boston, Mass.; Grafke & Stanek, Chicago; Walter E. Hayward, Attleboro, Mass.; and the Middletown Silver Co., Middletown, Conn.

A meeting of the creditors of Louis Witsenhausen, against whom bankruptcy proceedings were begun a short time ago, was held at the office of Referee Willis, 36 Wall St., last Thursday, at which time a compromise was offered on a basis of

50 per cent., 10 cents in cash and the balance in notes of four, eight, 12 and 16 months. A special meeting will be called at the same place Friday to consider the offer.

A. & S. Esposito, lapidaries and precious stone dealers now at 12-16 John St., have leased quarters in the new building at 15-49 John St., into which they will remove about May 1. The style of the firm is to be changed to A. & S. Esposito Co., the partners being A. and S. Esposito and Stephen Varni. In the new home the concern expects to increase its lapidary department, and also carry a full stock of precious and semi-precious stones.

The first afternoon's sale of the Azeez Khayat collection of ancient iridescent Phœnician, Greek and Roman glassware, dating from 1000 B. C. to 200 A. D., attracted many lovers of the antique in art to the Fifth Ave. Art Galleries last Wednesday. The amount realized from the sale was \$1,814. The highest price paid was \$220, for a large, three-handled Babylonian glazed pottery jar, 22 inches in height, with a diameter of 12 inches.

David Urbach, who for the past 17 years has conducted a jewelry store at Keyport, N. J., has sold his business to I. Prager, of this city, and after settling up his business affairs will take a well-deserved rest from business cares for a while. Mr. Urbach, accompanied by his family, will take a trip to Europe, leaving New York March 17 on the *Kronprinzessin Cecile*, and expects to be away until September. After visiting Austria and other sections of the Continent, Mr. Urbach will return to New York, where he expects to re-engage in business.

William B. Shaw, formerly of the Barrett-Shaw Co., 32 W. 34th St. and 221 W. 125th St., which recently went into bankruptcy, filed an individual petition in bankruptcy last Thursday, with schedules showing liabilities of \$36,284 and no available assets. He holds 25 shares of stock of the Barrett-Shaw Co., which are of no actual value. The largest creditor is Elizabeth B. Griggs, who has a claim for \$25,600. She holds five of his notes, each for \$5,000. The other creditors include the New Netherland Bank, \$7,553, on notes of the Barrett Shaw Co., which he indorsed; Gustav Blumenthal, \$1,664, and Brill Bros., \$1,467 for rent.

President Leo Wormser of the Jewelers Board of Trade has appointed the members of the "Good and Welfare" committee which it was decided to establish at the last annual meeting of the organization. This committee, which is to look after matters of general interest to the trade not within the scope and jurisdiction of present standing committees, will consist of Meyer D. Rothschild, of the American Gem & Pearl Co., chairman; George R. Howe, of Carter, Howe & Co.; Samuel H. Levy, of L. & M. Kahn & Co.; Frederick H. Larter, of Larter & Sons, and George D. Lunt, of the Towle Mfg. Co., with President Wormser, a member *ex-officio*. The committee will probably hold its first meeting this week.

Burglars broke into the store of J. Arisohn, 94 Columbus Ave., early last Thursday morning by "jimmying" the staple on

the outside door of the store and picking the lock, and escaped with about \$300 worth of goods, including a fan which had been left there for sale. The fan, which was valued at \$150, was made of mother-of-pearl inlaid with gold, and is said to be over 100 years old. Mr. Arisohn, in speaking to a CIRCULAR-WEEKLY reporter about the robbery, said that the jewelry taken consisted of two gold purses, a number of rings, brooches, pins, earrings and other small pieces of jewelry valued at about \$150. There were indications on the safe showing that a drill had been used on it. None of the watches belonging to customers was taken, as all were in the safe, together with the more valuable jewelry. The police were notified, but the thieves have not as yet been found.

Included in the list of recent accessions at the Metropolitan Museum of Art are three small gold objects, Egyptian (gift of James Douglas); one bronze cuirass, Greek, fifth century B. C.; one bronze casque, Roman, fifth or fourth century B. C.; one bronze conical-shaped casque, early Italiote, fifth century B. C.; one bronze casque from Capua, sixth century B. C.; two bronze casques, Roman, third or fourth century B. C. (purchase); five examples showing process of Deruta (or Majolica) tile-work (gift of Gardner Teall); 11 silver, bronze and copper medals from various countries (gift of Mr. and Mrs. Frederick S. Wait); a bronze medal, Universal Exposition, St. Louis, 1904, by A. A. Weinman (gift of Clarence Hoblitzelle); a bronze portrait medallion of Washington Irving, by H. K. Bush-Brown (gift of the Saint Nicholas Society); Mrs. George A. Hearn's collection of watches (gift of Mr. and Mrs. George A. Hearn); History of Gems, Raleigh, 1907 (gift of Dr. George F. Kunz); terra-cotta model of a fountain, by Giovanni da Bologna (gift of J. Pierpont Morgan), and two vertical sun-dials, English, 18th century (purchase).

A meeting of the creditors of S. Hart, Waterbury, Conn., was held at the Everett House, New York, Tuesday afternoon, Feb. 11, at which time an offer of settlement was made by the debtor of 25 per cent., but later he raised the offer to 30 per cent., to be paid in notes indorsed by Levy Bros., Waterbury, Conn. This offer is to be accepted by all creditors with the understanding that if he were successful in persuading the attaching creditors to release the \$2,400 insurance money immediately he would pay the 30 per cent. in cash. Attorneys for Henry Cowan and I. Alberts agreed to accept the 30 per cent. The other creditors, many of whom were represented by agents, were not in a position to state what they would do. According to the statement made at the meeting, the stock of the debtor before the fire in December, 1907, was valued at about \$9,000, upon which he held an insurance policy of \$3,000. On this policy \$2,400 was allowed. The insurance money was attached by the Peerless Rubber Co. and other creditors. The stock at this time is, according to the statement made at the meeting, is valued at about \$1,000, although it is thought by some of the creditors that more than that amount can be realized from it. The

ESTABLISHED 1852

THE NASSAU BANK

Original Clearing House Member

Corner Nassau and Beekman Streets - - - - NEW YORK

Title Guarantee and Trust Co.

176 Broadway (between John St. and Maiden Lane), New York

Capital and Surplus - - - - \$12,000,000

Deposits received subject to Check. Interest allowed. Letters of Credit issued. Drafts drawn on Great Britain and the Continent. All Banking Facilities afforded to Customers. Accounts of Jewelers are especially solicited.

Finance Committee in Charge of Banking Interests

E. T. BEDFORD, 26 Broadway
C. H. KELSEY, President
E. L. MARSTON, of Blair & Co., Bankers
W. H. NICHOLS, General Chemical Co.

CHARLES A. PEABODY, President Mutual Life Ins. Co.
JACOB H. SCHIFF, of Kuhn, Loeb & Co.
JAMES SPEYER, of Speyer & Co.
E. O. STANLEY, 2d Vice-President

BRANCH BANKING OFFICES: 196 Montague St. and 175 Remsen St., Brooklyn; 350 Fulton St., Jamaica; 67 Jackson Ave., Long Island City

The Market and Fulton National Bank of New York.

ORGANIZED 1852

81-83 FULTON STREET.

Capital, \$1,000,000.

Surplus, \$1,500,000.

PROGRESSIVE — CONSERVATIVE — SUCCESSFUL.

ALEXANDER GILBERT, President.
R. A. PARKER, - Vice-President.
T. J. STEVENS - - - Cashier.
JOHN H. CARR - Asst. Cashier.

Invites the Accounts of Jewelers.

Will extend every facility that good banking will justify

SAFE DEPOSIT VAULTS.

THE STATE BANK

376-378 GRAND STREET, NEW YORK

Capital and Earned Surplus, over \$1,500,000. Deposits over Fifteen Million.

Offers a favorable market for short and long time jewelry and diamond paper.

The Mercantile National Bank

OF NEW YORK

February 4, 1908

ASSETS

Loans and Discounts	\$6,992,758.84
U. S. Bonds.....	1,009,125.00
Bonds to Secure U. S. Deposits	959,357.50
Real Estate and Securities	1,018,800.00
Due from Banks and Bankers	341,581.72
Exchanges for Clearing House	286,689.24
Cash	1,395,968.50

\$12,004,280.80

LIABILITIES

Capital	\$3,000,000.00
Surplus and Undivided Profits	2,407,236.31
Bank Notes Outstanding	975,000.00
Deposits	5,285,044.49
Bond Account	337,000.00

\$12,004,280.80

SETH M. MILLIKEN, President

MILES M. O'BRIEN, Vice-President

EMIL KLEIN, Cashier

WM. SKINNER, Vice-President

ALFRED W. DAY, Assistant Cashier

GERRISH H. MILLIKEN, Vice-President

DIRECTORS

WILLIAM F. CARLTON,
WILLIAM NELSON CROMWELL,
EDWIN GOULD,
HAROLD A. HATCH,
EDWARD T. JEFFERY,

GERRISH H. MILLIKEN,
BENJAMIN NICOLL,
MILES M. O'BRIEN,
CHARLES E. PERKINS,
DICK S. RAMSAY,
JOHN F. KEHOE,

GEORGE H. SARGENT,
WILLIAM SKINNER,
WILLIAM H. TAYLOR,
WARNER VAN NORDEN,
S. M. MILLIKEN.

Strictly a Commercial Bank
Accounts Solicited

1851

THE JEWELERS' BANK FOR HALF A CENTURY
IN THE SAME LOCATION

1908

The Chatham National Bank

Broadway and John Street
New York

CAPITAL - - - - -	\$450,000
EARNED SURPLUS - - - - -	\$1,000,000

NOT CONNECTED WITH ANY OTHER INSTITUTION, OR CONTROLLED BY ANY SINGLE INTEREST,
INVITES THE ACCOUNTS OF MERCHANTS, FIRMS AND BUSINESS CORPORATIONS, AND IS
PREPARED TO EXTEND EVERY FACILITY CONSISTENT WITH CONSERVATIVE BANKING

Directors

GEORGE M. HARD, President
JOHN H. WASHBURN, Retired
SANFORD H. STEELE, Vice-President
General Chemical Co.
FRANK R. LAWRENCE, Attorney
DANIEL J. CARROLL, Lumber
JOHN D. VERMEULE, President
Goodyear India Rubber Glove Co.
G. P. MOROSINI, Banker

HENRY F. SHOEMAKER, Banker
WILLIAM B. CONRAD, White Goods
FRANKLIN S. JEROME,
Treasurer U. S. Finishing Co.
FRANK J. HEANEY, Exporter
SAMUEL WEIL, Capitalist
LEWIS COON, Real Estate
O. G. FESSENDEN,
of Hayden W. Wheeler & Co.,
Jewelers.

GEORGE M. HARD, President

WILLIAM H. STRAWN, Cashier

HENRY L. CADMUS, Assistant Cashier

New York Notes.

(Continued from page 65.)

tor claims to owe about \$11,000 distributed among about 150 creditors, and of this amount he claims to owe about \$1,800 in borrowed money.

The Knickerbocker Jewelry Co., Inc., has sold out to Arthur M. Hirshfeld.

Morris Rosenbaum, formerly located at 55 First Ave., has moved to Long Island City.

M. Loeb, of the Dueber-Hampden Watch Companies, was a visitor in this city last week.

Geo. H. Rosenblatt, 229 Broadway, sailed for Europe yesterday on the *Kronprinzessin Cecilie*.

Mr. and Mrs. Wm. Barthman sailed on the *Hamburg*, of the Hamburg-American line, last Saturday.

Joseph Fahys, accompanied by his wife, left Saturday on the White Star liner *duc* for the Mediterranean.

Charles Alschul, formerly with Oppenheimer Bros. & Veith, will in the future represent the Wm. C. Penfold Co., 35 Maiden Lane.

Judge Hough, in the United States District Court, has granted a discharge in bankruptcy to John V. A. Cattus, importer of Japanese goods, 98 Front St. Liabilities are \$399,000.

A bulletin of the Merchants' Association of New York has just been issued, in opposition to the Aldrich Emergency Currency bill and containing the report of a committee on bankruptcy and commercial law. The report gives several reasons why the committee do not consider the billavorably.

The Boost Club, of New York, is making arrangements to have Col. William Jennings Bryan present at a regular monthly meeting of the club in April. C. B. Haller, chairman of the entertainment committee, and W. P. Christopher, chairman of the publicity committee, have been appointed special committee to arrange for a minstrel show, to be given by the members of the club, some time late in the Spring.

Schedules in bankruptcy of Samuel Rubin, filed last Friday in the United States District Court, New York, show liabilities of \$3,007.55, with assets of \$1,700, consisting of cash on hand and money deposited in banks. A stock of \$1,500 has been turned over to the receiver. Among the unsecured creditors are: Arsenstein & Worsock, \$502; Herman J. Dietz, \$838; Henry Avidson, \$376; A. Dorfhofer, \$135; Herzfelder & Kohn, \$126; H. Bamm, \$123; Brones Bros., \$164; Levinson & Friedlander, \$485; M. S. Stern, \$179; Jos. Risen, \$200; Empire Silver Plate Co., \$110; J. Freudenheim & Son, \$566; Gordroin & Untz, \$119; R. L. & M. Friedlander, \$102; Lipper Bros., \$195; I. Ollendorf, \$119; Kaubheim Bros., \$186; Edward K. Tryon Co., \$225.

The subscriptions which have been collected in the trade by Leopold Stern for the benefit of the Hospital Saturday and Sunday Association, of New York City, already amount to \$940. The contributions are as follows: Stern Bros. & Co., \$50; Kerner & Untermeyer Mfg. Co., \$50; Arn-

stein Bros. & Co., \$50; Oppenheimer Bros. & Veith, \$50; Bruhl Bros. & Henius Co., \$50; J. R. Wood & Sons, \$50; L. M. Kahn & Co., \$50; Albert Lorsch & Co., \$50; S. L. Van Wezel, \$50; Kastenhuber & Lehteld, \$25; Chester Billings & Son, \$25; Eichberg & Co., \$25; M. B. Bryant & Co., \$25; L. Strasburger's Son & Co., \$25; Sussfeld, Lorsch & Co., \$25; Benedict Bros., \$20; Graff, Washbourne & Dunn, \$20; W. I. Rosenfeld, \$10; C. F. Wood & Co., \$10; Jung & Klitz, \$10; Jonas Koch, \$10; Zimmern, Rees & Co., \$10; Max Rosenberger, \$10; Hayden W. Wheeler & Co., \$10; Carter, Howe & Co., \$10; I. Roseman, \$10; J. B. Bowden & Co., \$10; J. King Optical Co., \$10; Goodfriend Bros., \$10; N. H. White & Co., \$10; Freudenheim Bros. & Levy, \$10; Shiman Bros. & Co., \$10; American Watch Case Co., \$10; A. H. Smith & Co., \$10; Byron L. Strasburger & Co., \$10; J. Strauss & Sons, \$10; Ciner & Seclaman, \$10; Marchand Freres, \$10; L. Heller & Son, \$10; Jos. H. Turk & Co., \$10; Jacobson Bros., \$10; S. C. Powell & Co., \$5; H. Goldsmith & Son, \$5; Herman & Kramer, \$5; Rudolph & Snedeker, \$5; Ludeke & Heiser, \$5; Smith & North, \$5; Cross & Beguelin, \$5; Aikin, Lambert Co., \$5; H. Nordlinger Sons, \$5; A. Schwab, \$5; David Kaiser & Co., \$5; Bodenheimer & Jaskow, \$5.

Newark.

Harry G. Young, who is now a traveling representative for Owen, Steeber & Co., 67 Hamilton St., has started on his first trip for that concern. He will visit the trade in Baltimore, Pennsylvania and Ohio.

The residence of E. R. Cook, of the firm of Cook & Jaques, at 527 E. State St., Trenton, N. J., was entered by burglars early last Thursday evening. This is the second time this season that burglars have plied their calling at the Cook residence, and as in the previous instance little of value was taken. The loss is estimated at about \$50.

Samuel T. Langdon, of Scranton, Pa., who was arrested in New York last September on a charge of stealing two diamond rings, valued at \$1,225, obtained on memorandum from J. Wiss & Sons, has pleaded guilty and was fined \$1,000 by Judge Ten Eyck, Monday. Langdon's brother made restitution to the jewelry firm. Mr. Wiss said that the pawn tickets for the rings were found on the prisoner's person and the goods were redeemed and returned to him.

A bold daylight robbery was effected in the jewelry store owned by John Gero, 59 2d St., Passaic, N. J., Tuesday afternoon, Feb. 11. The thief, evidently a woman by the clue which she left, had presumably entered the store with the intention of making a purchase, but upon finding the store empty took 12 watches valued at about \$50 from a show case in the window, and in her haste to get out left behind a bundle of underclothing. The police were notified and are now working on the case.

Death of Thomas F. Weale.

BALTIMORE, Md., Feb. 17.—Thomas F. Weale, of the old firm of Geary & Weale, died Friday, in his apartment, at the Hotel Belvedere, of congestion of the lungs. Mr. Weale was born in London, 71 years ago, coming to this country when 18 years old.

On arriving in Baltimore he entered the employ of James and George Haig, at 223 W. Baltimore St., remaining there for a number of years. He then formed a partnership with Charles A. Geary, under the firm name of Geary & Weale.

At the death of Mr. Geary, about 38 years ago, he continued to conduct the business under the old firm name until eight years ago, when he retired. The firm in those days was one of the most prominent in the city, and it is said Mr. Weale died wealthy. For a few years prior to his retirement the business was managed by Thomas Hall, who is at present with the J. S. MacDonald Co. Mr. Weale never married.

The funeral took place this afternoon from the home of his cousin, John F. Tribble, 1104 Mount Royal Ave., the burial services being conducted by Rev. Dr. A. B. Kinsolving. Interment was in Greenmount Cemetery.

Short Change Swindler Gets Diamonds from Louisville, Ky., Jeweler.

LOUISVILLE, Ky., Feb. 13.—The "short-change" artist or "flim-flam" man who has been at work in the jewelry trade in other parts of the country, as told in THE CIRCULAR-WEEKLY recently, has evidently been in Louisville, as Richard G. Tafel, a jeweler at 22 W. Market St., was visited by a man of that character Wednesday, and is now mourning the loss of \$575 worth of diamonds in payment of which he has but \$15 in cash. The police have been notified, but have not yet captured the swindler.

The man, who answers the description of the fellow who operated in Cincinnati recently, visited Mr. Tafel's store Wednesday morning and asked to see some diamonds. As Mr. Tafel was away, the young woman in charge refused to sell them, but permitted the man to make a selection. He returned later and met the proprietor, picking out two diamonds on which he agreed to pay \$575 deposit if the jeweler would let him show them to his wife for her selection. The stranger handed the jeweler what he said was the amount, consisting of five \$100 bills, a \$50 bill and the remainder in \$1 bills. When Mr. Tafel counted it he found it was one dollar short, whereupon the swindler counted it himself, agreed with the jeweler and, rolling the bills up and putting a rubber band around them, handed them to Mr. Tafel with a silver dollar.

He immediately left the store with the diamonds, when Mr. Tafel discovered that he had only 14 one-dollar bills and a silver dollar.

Death of Joseph Bachman.

Joseph Bachman, who will be remembered by the older men in the trade as one of its former most prominent and respected merchants, died at his home, 54 W. 77th St., last Sunday. He was 91 years old.

Many years ago he was in business for himself on Grand St., and later at 3 Maiden Lane, under the style of Joseph Bachman & Co. Later, until about four years ago, he was connected with the Gorham Co.

The funeral services were held at Temple Emanu-El yesterday, of which congregation the deceased was a member. Surviving are four daughters and two sons. Mr. Bachman leaves many friends in the jewelry trade who deeply regret his demise.

The ADVANTAGE of BUYING

UR RINGS

SPECIAL FACILITIES
in the manufacture of
UR RINGS enable you to
buy them through your
JOBBER as advantageously
as such goods can be obtained
direct from manufacturers

The Untermeyer-Robbins Co.

Seventy-One Nassau Street, New York

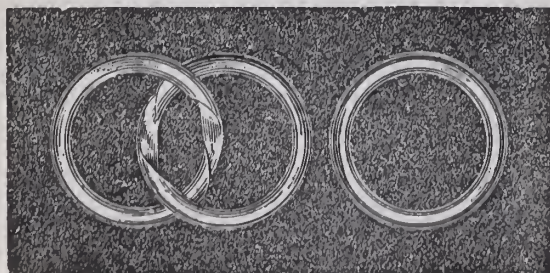

WE MAKE

The Alliance Ring

The graceful style of the Alliance Ring is rapidly supplanting the use of the old style wedding ring. The joints are invisible, and whenever engraving is desired it is done in the inside surface. Can be easily separated by inserting a pin in inside pin-hole.

14 karat, 3 dwts., each, \$1.25 per dwt.; in dozen lots, \$1.15 per dwt., net.
18 karat, 3 dwts., \$1.40 per dwt.; in dozen lots, \$1.30 per dwt., net.

MADE ONLY BY

LEONARD KROWER, Manufacturing Jeweler

536-538 Canal Street

New Orleans, La.

Columbus, O.

The Ohio Optical Association, last week applied for incorporation papers under the laws of the State of Ohio.

The store of Frederick Leindecker, 124 E. Mount St., was robbed Friday night of Saturday morning last of goods valued at \$200. A patrolman found the door open early Saturday morning and notified the proprietor. Investigation showed that the thief had gained entrance to a basement next door, then had cut a hole through the wall, about two feet in diameter, and thus gained entry to the cellar under Leindecker's. The store is located not far from Sculler Bros., on E. Main St., robbed recently, and the police think probably the two jobs were done by the same man.

The bill introduced in the Ohio House of Representatives by Mr. Reynolds, of Franklin County, in regard to inspection of railroad watches, is resting quietly in committee and will probably remain there, as both railroads and jewelers are watching to pounce on it the moment it shows any sign of life. The bill forbids any person engaged in the manufacture or sale of watches from acting as a watch inspector. Senator Deiman is allowing the optometry bill to remain in committee, waiting for opposition to show itself if there is to be any. If no opposition asks for a hearing the bill will be favorably reported and passed with a few minor amendments. The committee of the Ohio Optical Association which has the bill in charge, the president, F. P. Barr, and a number of Columbus opticians, met in Columbus Thursday to discuss informally what these changes shall be.

Toledo.

Toledo jewelers are among those who have suffered losses through the use of forged checks on a former bank doing business in this city. Some months ago three local savings banks combined and the forged checks were on one of the banks entering the consolidation.

The Toledo police is trying to connect George Arcand, who claims Montreal, Canada as his home, with a number of jewelry robberies. Arcand was arrested here last week on the charge of suspicion and when searched was found to have several hundred dollars' worth of diamonds, watches and other kinds of jewelry on his person. Aside from these, his trunk, which was searched at his lodging house, was literally filled with all kinds of jewelry. The police of both Montreal and Detroit were notified.

The Grand Jury of Hancock County, which Findlay is located, 50 miles south here, has just indicted J. C. Moran, of this city, and Joseph Laboon, of Pleasant Beach, under a blanket charge covering large burglary, robbery and cutting with intent to wound. The capture of the two men was accomplished shortly after the jewelry store of J. C. Thompson, Findlay, had been robbed of a tray containing several hundred dollars' worth of diamonds. A number of the stones were recovered with the capture of the robbers, and it is said that as soon as the Hancock County officials get through with them, the two men will have to answer to similar charges in other counties in this section of Ohio.

Providence.

Willis Coates, an importer of Rockville, Nt., was in this city last week, making large purchases.

John Shepard, Jr., who is deeply interested in the jewelry department of his father's store on Westminster St., has gone south to recuperate.

Forty-nine new members have been added to the New England Manufacturing Jewelers and Silversmiths' Association during the past three months. There were 10 applications for membership at the last meeting.

A gas heater in one of the shops of the George W. Dover Co., 80 Clifford St., ignited the woodwork of the shop one morning last week. The firemen were called and had little trouble in extinguishing the blaze. The damage was slight.

In order that payment may be secured on promissory notes, an attachment has been placed on the property of the A. S. Sumnerford Co., gold platers. The action was brought by Frederick E. Tattersall, and it is thought that a compromise will be effected in a few days. The business has run the latter part of last week under the direction of the deputy sheriff who served the writ.

The stockholders of the United Wire & Supply Co. held their annual meeting during the past week and elected the following officers: President, Henry F. Smith; vice-president, William B. Gladding; secretary and treasurer, Albert E. Stevens; general manager, Henry T. Smith; assistant manager, William F. Kilkenny. The following directors were also elected: Henry T. Smith, Henry T. Smith, William B. Gladding, William H. Parks, Clovis H. Bowen, Henry G. Fletcher, Charles Payne, George B. Champlin and Henry J. Spooner.

A fire alarm was sounded Feb. 10, bringing the apparatus to the Hanley building on Aborn St. The building is occupied by the George W. Parks Co., silversmiths, and Fox & Saunders, jewelry card printers. There was no fire, but a sprinkler had burst, deluging the building with water and causing the alarm bells to sound. Similar damage was caused to firms in the Greene building, on Fountain St., the same morning, when a sprinkler burst and water flowed freely into jewelry shops in that building until the firemen came and shut the water supply off.

The Cornell & Andrews Co., Inc., which has a refinery in this city and another in Meriden, is seeking to effect a settlement with creditors. It is understood that the concern is in financial difficulties arising from change of ownership of stock following the death of William O. Cornell, one of the firm, who died some two years ago. The concern is offering to meet all claims less than \$500 on a cash basis, and will pay 62½ cents on the dollar to all claimants to whom it is indebted in excess of \$500. As far as can be ascertained the concern has few creditors in this city. Its branch in Meriden will be continued, but the fate of the local refinery is problematical.

Joseph Sumner and Jacob Kotler, of the United Comb & Novelty Co., have been adjudged bankrupts. The bankruptcy is not against the firm, as the two men men-

tioned presented their petitions individually as co-partners. Their affairs are now in the hands of the trustee in bankruptcy. The liabilities are stated at \$19,348 and assets as \$25,200. Jacob Lederer, Albert Figos and Marion B. Carr are among the largest creditors. The personal property named as assets consists of 88 shares of the United Comb & Novelty Co., which is subject to liens. The assets are: Real estate, \$9,900; stock, \$700; personal property, \$14,000, and property in reversion, \$700.

A fire, which was caused by a defective oil stove in Frank Miner's jewelry shop on the top floor of the four-story building at Eddy and Middle Sts. gutted that shop early last week and caused damage estimated at \$5,000. Several young women working in the place had narrow escapes and were gotten out of the burning building with difficulty. Mr. Miner, in attempting to extinguish the fire with a pail of water, was slightly burned. The stock of the shop was ruined and large quantities of cheap jewelry were thrown into the street. The next morning Middle St. was crowded with men and boys who had heard that a bucketful of diamonds had been thrown into the street. Instead they found several cheap stickpins and emblems.

The Irons & Russell Relief Association held its annual meeting in Prescott Post Hall, Tuesday evening of last week. Following the election of officers a vote of thanks was extended to Messrs. Irons and Russell for a generous cash donation made to the association and a banquet was held. A minstrel show was given by employes of the shop, at which George Casey acted as director. The officers of the association were elected as follows: President, Richard Skuce; vice-president, Gilbert Whittemore; treasurer, Emily H. Paine. The soloists during the minstrel show were: Thomas McDermott, George Cuddyer, Louis Gorton, John Cummings, James Jordan, George Casey, Hugh Donahue, Fred Mack. The accompanist was Miss Florence McDermott. John Cummings acted as interlocutor.

The shops of the Gorham Mfg. Co. in Elmwood resumed their regular schedule of working hours last week. The plans reopened Monday morning, Feb. 10, with its full force of 1,700 hands at work. The shop had been running on a 44-hours-a-week schedule from Thanksgiving week until about three weeks ago, when a lay-off of two weeks was taken in order that an inventory might be made. Last week Superintendent Lawton stated that the resumption of the regular schedule was due to a general improvement in business conditions and more settled affairs. He said that business is getting to its own level again, and that while the outlook is not as bright as it was last year it is not half so erratic as it was two months ago. "Business," said he, "has not resumed a normal state, but it is showing a gradual improvement."

During a fire, which occurred at Xenia, O., about a week ago, George Charters, a retail jeweler, sustained a loss of \$50. It has been estimated that the damage done to the entire business district amounted to several hundred thousand dollars.

North Attleboro.

H. H. Curtis left, Sunday, on a business trip.

Ira Richards and wife have gone to Havana, Cuba.

Henry F. Barrows was in New York, last week, on business.

A. B. Chace has returned from a western trip for F. S. Gilbert.

K. L. Taylor, western representative of Riley & French, was at the factory last week.

George S. Semple, New York representative of the W. & S. Blackinton Co., was at the factory several days the early part of the week.

James Carley, Plainville, is the new foreman of C. O. Sweet & Son. He succeeds M. F. Halon, who has gone into business for himself in North Attleboro.

In the case of Edward Trembly, charged with the theft of gold links from the Estate of O. M. Draper, the jury reported a disagreement after being out an entire day. It is said that the jury stood six for conviction and six for acquittal. A new trial has been ordered. Frederick De Grenier was sentenced to four months in the House of Correction for breaking and entering the factory of F. S. Gilbert and stealing bracelets. He changed his plea of not guilty to guilty.

A hoop broke last week on the big water tank in the Union Power building, and tons of water poured out down into the shops. The accident happened during the evening and consequently had sufficient time to do a lot of damage before being discovered the next morning. The offices of F. S. Gilbert, Furbish, Swift & Fisher and F. I. Gorton were flooded and hundreds of dollars worth of damage was done to boxes and stationery. The damage was particularly heavy in the Gilbert and Furbish, Swift & Fisher offices. To make matters worse the night was intensely cold and the water froze into layers of ice.

Harrisburg, Pa.

Merchants of West Fairview, Enola and vicinity, immediately opposite Harrisburg, have organized a Retail Merchants' Association, with these officers: J. H. Harm, president; Robert Bretz, vice-president; J. P. Kessler, secretary, and H. M. Glessner, treasurer. The 7.30 p. m. closing movement has been adopted.

At the 50th anniversary jubilee of Messiah Lutheran Church, last week, a handsome bronze memorial tablet erected to the memory of the late Prof. L. O'Toole, for many years city superintendent of schools, was unveiled with appropriate exercises. The tablet is mounted upon a base of solid oak and suitably inscribed.

At the annual meeting of the local Board of Trade, last week, these officers were chosen: President, Chas. A. Disbrow; secretary, James A. Bell; treasurer, W. L. Gorgas; trustees for three years, Chas. A. Kunkel, J. C. Harlacker, E. Z. Gross, David E. Tracy, Dr. Galen Hain; for one year, William Strouse; auditors, A. D. Bacon, H. C. Demming, G. Walter Spahr. P. G. Diener was made a member of the membership committee.

Wolcott Manufacturing Co.



PATENTS PENDING

The Fashion



Collar Pins



An absolutely new article which sells at sight. Try it

MANUFACTURED IN ROLLED PLATE BY

Wolcott Manufacturing Co.

71 PECK STREET, PROVIDENCE, R. I.

NEW YORK OFFICE, 14 MAIDEN LANE

Attleboro.

Orlando W. Hawkins forgot factory cares for a fishing trip on Cape Cod last week, returning with a creditable string of pickerel.

W. S. Austin has joined the traveling force of the C. H. Eden Co. and will make his first trip with its samples about March 1.

Hon. S. O. Bigney addressed a public meeting in Bates Opera House, Sunday, on the proposed legislation for State prohibition of the liquor traffic.

Thomas E. McCaffrey, who is financially interested in one of the jewelry houses here, was last week elected to the directorate of the Attleboro Mutual Fire Insurance Co.

The handsome dwelling of Frank Mossberg, of the Frank Mossberg Co., was endangered last week by fire starting in the cellar. Prompt work by the department prevented serious damage.

George H. Herriek, of the Geo. H. Herriek Co., left last week for a visit to Crescent City, Fla. This latter community is occupied by a prominent colony of former Attleboro families once conspicuous in the jewelry industry.

Michael Hanlon was the recipient of tokens of good fellowship last week at the factory of C. O. Sweet, Son & Co. He received a meerschaum pipe from fellow workers, a purse from the firm and flowers from the office employes.

In happy contrast to conditions in several of the factories the James E. Blake Co. added to its working force last week, and claims to be finding business fairly good. Mr. Blake sent out last week pictures and descriptions of the new home he has purchased, telling trade and personal friends that after June 1 they will find the catch-string out.

A meeting will be called some day this week of the creditors and others interested in the case of Leroy D. Braman, the jobbing jeweler who mysteriously disappeared Nov. 20. The preliminary hearing was held last week in Boston before the Court of Bankruptcy on the petition of the Board of Trade that he be declared bankrupt. The amount he left is not large, but if taken over by the court would provide a modest dividend to creditors. No efforts are now being made to locate Braman, nor has anything further been heard from him.

Col. Sidney O. Bigney, of S. O. Bigney & Co., was host last week for a large group of editors and publishers. The Massachusetts Press Association, holding its State convention in Boston, was invited to Attleboro *en masse*, and responded. At the factory the men of the party were given fobs and the women bracelets. Col. Bigney was asked to address them, and did so, emphasizing the need of successful business men in the United States giving more of their personal attention to politics—not necessarily for themselves, but as a means of protecting and building up the nation's industries.

An acid flue on the rear of the No. 3 factory building of the Robinson estate on Union street caught fire one night last week. The blaze was discovered before it communicated with the factory proper, and was extinguished before any other damage ensued than the destruction of the flue. The

flue was of wood and connected with the coloring departments of C. O. Sweet, Son & Co., J. M. Fisher & Co. and F. W. Weaver & Co. The fire started at the bottom and worked its way towards the top. An alarm was sent in from box 9 calling the entire central department to the scene. By the time the department arrived the blaze was smouldering the entire length of the flue.

The problem of aid for the hands thrown out of employment by the jewelry factories was taken up last week by the town authorities in answer to a long petition calling on them to begin street construction work at once to enable men to earn some small income. It is planned to do as suggested, and save a number of desirable residents from either drifting away from town or being obliged to seek the aid of the pauper department. There has been informal discussion among the jewelry manufacturers of the wisdom of giving preference to Attleboro residents and turning off those whose homes are in North Attleboro, Taunton, Mansfield and points in Rhode Island. In the families of many skilled jewelers the financial situation has become acute.

Canada Notes.

Horace Dorer, Westminster, B. C., has moved into more commodious premises.

Roy McGeachie, London, Ont., who has gone west, is succeeded by D. F. Johnstone.

W. G. Challoner, of Challoner & Mitchell, Victoria, B. C., passed through Toronto, last week, on his way to Europe.

James Rylie, of Rylie Bros., Ltd., Toronto, Ont., left Sunday, accompanied by his wife, for a European trip of about four months.

W. Frank Ross, who was in business many years ago on King St., Toronto, Ont., died, Feb. 11. He had been ailing in health for some time.

Albert Kleiser, Toronto, Ont., is suffering severely from the effects of a fall downstairs, resulting in internal injuries which are likely to lay him up for some months.

Ont-of-town jewelers calling on the Toronto, Ont., trade last week, included; H. Wendt, Clifford; R. N. Bassett, Whitby; Alex. Gibson, Peterboro, and J. H. Porte, Pieton, all Ontario.

Daniel Murray, Toronto, Ont., was sent to jail for a month, recently, on a charge of fraudulent use of the mails. He sent out circulars in the name of Murray & Co., manufacturing jewelers, offering \$25 worth of jewelry for \$6, 50 cents cash and the balance in instalments. His premises were searched and no jewelry was discovered, the alleged business being non-existent.

A. J. Allen and wife have left Montreal to enjoy an extended period of travel through the Mediterranean and on the Continent. Mr. Allen, who was an extensive traveler in his younger days, is already acquainted with what is to be seen abroad. He has been around the world twice and has visited all the principal cities in Europe. On this Continent he has visited every city in the United States that was a city 10 years ago. He has also been in every town and city in the Dominion of Canada on a railroad of 500 inhabitants and upwards, and many hundreds of smaller villages.

Boston.

Henry G. Morris has gone to Atlantic City for a week's outing, accompanied by Mrs. Morris.

S. M. Shore, now in Room 910 of the Jewelers' building, will remove March 1 to Room 63 on the sixth floor.

C. S. Blake, now on the fourth floor of the Jewelers' building, will remove to Room 74 on the seventh floor next Monday.

A. Mendelsohn, of Mendelsohn Bros., sailed for Europe last Saturday on the *Kaiserin Auguste Victoria* from New York.

Joseph Van Ulm, heretofore inside salesman, goes on the road this week in northern New England territory for Mendelsohn Bros.

C. W. Davidson, of the Thomas Long Co., accompanied by Mrs. Davidson, is on a recreation trip to Pennsylvania and southern points.

Joseph Cowan started on a western trip Monday last, and at the same time G. W. Colwell, his southern salesman, started on a trip over his regular territory.

The jewelry store of Allen A. Barrett at 777 Main St., Campello, was entered through a rear window by burglars last week and jewelry to the value of \$100 stolen.

Herbert N. Libby, formerly with Charles May & Son, and during the past year with Henry Cowan, has re-entered the employ of the former concern and will have charge of the nautical department.

Buyers visiting Boston during the week included: E. G. Tucker, Worcester; H. B. Howland, New Bedford; Mr. Tisdale, Taunton; M. F. Wood, Lowell; Mr. Gurney, Gurney Bros., Brockton.

The Massachusetts Bureau of Statistics of Labor issued a report last week on the number and character of the appeals made to the State free employment bureaus in 1907. It is significant that not a jeweler asked work.

M. N. Smith and H. W. Patterson, of the Smith-Patterson Co., went to Montreal last week to attend the annual meeting of the Smith-Patterson Co., Ltd., of that city, which was held Feb. 11. The annual report showed a prosperous trade year.

Edward E. Howard and Allan W. Pollard, of the Pollock building, have decided, with mutual good-will, not to renew their partnership agreement of the past five years which has just expired. Mr. Pollard retains the old location of the firm and Mr. Howard will locate in Room 624, Tremont building.

Lewis L. Knott, for the past 18 months with the Shreve, Crump & Low Co., has severed his connection with the establishment. He is succeeded by Charles Barlow, who has been for some time past with the Smith-Patterson Co., but now returns to the position as salesman previously held by him in the employ of the Shreve, Crump & Low Co.

The United States Optical & Findings Co., Camden, N. J., has been incorporated under the laws of the State of New Jersey, with a capital of \$100,000. The incorporators are: John S. Drake, Melvin S. Garris and Amos S. Thomas. The company is to manufacture optical goods.

Pittsburg.

S. Davis has gone to the seashore because of illness and expects to remain there for two months in the hope that he will benefit his health.

C. C. Marsh, of the Marsh, Brown & Mather Co., who has been seriously ill for several months, is said to be improving. He is still at Mt. Vernon with his sister.

Charles W. Wattles, of W. W. Wattles & Sons, is spending the month of February in Florida, and Mr. and Mrs. W. W. Wattles will join him at the Clarendon, Sea Breeze, Fla., and will start to-morrow on their trip.

Frank T. East, of E. P. Roberts & Sons Co., made an address last week favoring annexation of Bellevue to Pittsburg. A number of jewelers live there and the contest is exciting more than usual interest because of the fight being waged. Some jewelers are lined up on both sides.

The banquet, held last week at the Hotel Schenley, by the Pittsburg Chamber of Commerce to celebrate the birth of the martyred Lincoln, was a triumphant success, the most brilliant affair ever given in Pittsburg, and a number of jewelers were present. Incidentally it took the form of a boom for Senator P. C. Knox for the presidency.

Charles G. Lintner, of 1036 Sandusky St., North Side, was brought to Pittsburg last Monday from Chicago by Detective Fred Dillon and pleaded guilty to a number of charges of forgery involving amounts aggregating \$90. He was held in \$500 bail for trial. All of the checks forged were signed "James P. Hickey" and were drawn on the Federal National Bank. Loftis Bros. & Co. were among the victims.

The jewelry store of Bernard Bien, at 2220 Forbes St., was robbed some time prior to 11.30 p. m., Feb. 11, of three diamond rings, 12 signet rings and other jewelry valued at \$200. The burglars cut a hole in the window and removed the stock. Bien had left the lights burning in the store and when he returned at the hour stated above to turn them out he discovered that his place had been robbed. The police are investigating, but there is no clew.

The Jewelers' Duckpin Bowling League has been organized in this city and the opening game was rolled last week. Four teams were incorporated at a recent meeting, representing the houses of E. P. Roberts & Sons, W. W. Wattles & Sons, Henry Terheyden and J. R. Reed & Co. In the inaugural match the Wattles team won two out of the three games from the Roberts trio, having high score of 96. The Wattles team is composed of Messrs. Crawford, Fowler and Stitt; Terheyden team, Messrs. Star, Brose, Minhall and Wells; Roberts team, Messrs. Parlett, Fogel and Klein; Reed team, Messrs. Kunsclmen, Senn and Whitman. It is the intention to make the league a six or eight club affair, and already the greatest interest is being manifested. The first game was rolled on the Dispatch alleys in Fifth Ave. A large number of jewelers were present to see the fun.

Michael McNally, alias Thomas Breen, was arrested near the Pittsburg & Lake Erie Railroad station last week on suspicion, and it was later discovered that he had en-

tered and robbed the jewelry store of the G. C. Murphy Co. at 313-315 Market St. When searched some of the plunder was found in his possession. Shortly after midnight McNally climbed to the roof of the building and, placing a scantling over a skylight, he tied a rope to it and made his way to another roof, but instead of being lowered to the roof as planned his feet went through another skylight and he fell into the store. His head was badly cut by the fall. He rifled the jewelry cases in the store and secured 223 rings, which were not very valuable, and then made his way from the building and started for the South Side, but was later arrested.

Philadelphia.

Wm. T. Miller, watchmaker for the trade, 124 S. 8th St., was painfully injured last week by falling from a street car.

About 500 guests are expected to attend the 13th annual banquet of the Philadelphia Jewelers' Club, Saturday evening, at the Bellevue-Stratford Hotel.

L. P. White and Wm. H. Morris, of the Jewelers' Club, leave next week for the south, where they will meet the Athletic baseball nine of this city and spend some time with them.

J. Emmott Caldwell, of J. E. Caldwell & Co., who was recently married, leased last week the country seat of Joshua L. Baily in Wynnewood, Pa., which he will occupy with his bride early in the Spring.

The first meeting of the creditors of Sperling & Goodman, bankrupts, formerly of 8th St., near Vine St., will be held Thursday of next week before the referee, David W. Amram, at 710 Penn Square building.

A. Goodman, a traveling representative of Durand & Co., is seriously ill with gastritis at the Bellevue-Stratford Hotel, in this city. Mr. Goodman was attacked early in the week and has since been under the care of a physician.

Fred. T. Barry, with J. A. & S. W. Granbury, returned last week from an extended western trip and returned at once to his home in Germantown, a suburb of this city. Mr. Barry declares that business is brisk in both St. Louis and Minneapolis.

Among the out-of-town retailers buying here during the week were: H. S. Kratz, Souderton, Pa.; W. K. Schlotterer, Schwenksville, Pa.; George Bowen, Bridgeton, N. J.; H. B. MacFarland, Downingtown, and D. H. Krause, North Wales.

Louis Stern, of Louis Stern & Co., has returned from an extended trip through the west, the first he has made in six years, and visited Chicago, Cincinnati, Pittsburg, Cleveland, St. Louis and other commercial centers, where he renewed acquaintanceship with old friends in the jewelry trade.

George W. Long, 1625 South St., jeweler and optician, was awarded the contract by the city authorities last week to furnish all spectacles and eyeglasses prescribed by physicians of the Bureau of Health for school children who cannot afford to pay a regular oculist or optician. The city pays Mr. Long for the glasses and his professional work.

Bernard Italic, of the Koshland & Italic

Co., is convalescing from a heavy cold which for a time threatened to develop into pneumonia. Mr. Koshland was a guest Friday night at a banquet celebrating the reunion of old Central High School classes at the Majestic Hotel. He is secretary of the 82d class. Thomas Campbell is touring Pennsylvania and reports an improved business condition throughout the section he has visited.

The Bailey, Banks & Biddle Co. is making what is reported to be the first exhibition of bone china made in this country. Several hundred pieces are on view, which are regarded as equal, not better, than the bone china manufactured in England, which country has long been given the highest place in the industry. Some fine pieces of Belleek china are included in the exhibit, as well as silver deposits ware, the silver decorations being put on by an electrical process, after which the engraving is done.

What was at first reported as having been a bold attempt to rob the jewelry store of William J. O'Donnell, 1004 Chestnut St., in broad daylight, Thursday, later turned out to be only a drunken man's mistake in trying to enter the place under the impression that it was his own home. But the police nevertheless are holding William Bailey Fogarty until such time as he is so far recovered that he will not make a similar mistake again. His awkwardness caused him to break a window and directly led to his arrest.

In noting last week that John N. Taylor, Jr., was to establish himself in business at 11 S. 9th St., in the store occupied formerly by Charles H. Stockwell, mention was unfortunately omitted of the fact that C. L. Bauer, optician, who has carried on an optical business for two years at this location, would remain there. Since Mr. Stockwell's death Mr. Bauer has taken a lease of the entire store and rented a part to Mr. Taylor, but he will continue his optical business without change at the old address in the other part of the store.

Traveling salesmen and executive officers of big firms were more than ordinarily active in this city last week. Among those who visited the trade were: Percy Savoy of the Wadsworth Watch Case Co.; T. Zurbrugg, of the Philadelphia Watch Case Co., Riverside, N. J.; Charles Willeman, of T. G. Frothingham & Co., New York; Milton Wallenstein, of Silberman, Kohn & Wallenstein, New York; Frank Ryder, of Walter E. Hayward & Co.; James MacDonald, of the Walcott Mfg. Co., and Mr. Blecker, of William S. Hedges & Co.

As a further aid to the police in apprehending thieves, pawnbrokers of this city according to an order promulgated last week, are required to make a daily report to the police department of all articles of value taken in pledge by them. The number of the ticket must be given, amount loaned, article, material, style or kind; time received and, in the case of a watch, the maker's name, inscription numbers or other marks. The character of stone and setting must be given of articles of jewelry. Blank for these purposes will be issued soon by the department.

Robert Nelson & Co., Toledo, O., are offering to settle with their creditors on a basis of 33½ per cent.

Connecticut.

The new factory building of the Landers, Cary & Clark Co., New Britain, will shortly be equipped with two elevators.

Wm. Hough, of the branch office of the New England Watch Co., in San Francisco, Cal., is spending a short vacation in Waterbury.

Ross Huggins, until recently with the Aldrich-Murphy Co., Winsted, has left for Great Barrington, Mass., where he has taken a similar position.

C. H. Tibbits and J. P. Stevenson, Wallingford, were elected vice-presidents at the recent meeting of the New Haven County Jewelry Association, held in Meriden.

G. C. Edwards, president of the Holmes Edwards Silver Co., Bridgeport, at a recent meeting of the Hall, Elton Co., held in Waterbury, was also elected president of the concern.

President N. Burton Rogers, of the Rogers Silver Plate Co., Danbury, and F. Wilson, of the same place, have been elected directors of the Danbury Business Men's Association.

The jewelry store of Wm. Vogel, New Britain, was flooded with water one day last week, as the result of the freezing and consequent breaking of a water pipe in a room above the establishment.

The estate and business of the late Frank Lettich, New Haven, was ordered sold last week by the Probate Court, a report having been made that \$12,000 in cash had been offered for the business and real estate.

G. M. Egelston, for several years secretary of the Sessions Foundry Co., Bristol, contemplates retiring from active business this Spring and removing from Bristol. He and his wife intend to spend much time traveling.

Samuel Shore, Waterbury, who only about a week ago resumed his duties as foreman at the factory of the Waterbury Clock Co., Waterbury, after having been confined to his home for five weeks on account of blood poisoning, is again laid up with the same ailment.

The annual meeting of the stockholders of the Seth Thomas Clock Co., Thomaston, was held Tuesday afternoon of last week, and the following officers were re-elected: President, W. T. Woodruff; vice-president, F. D. Bradstreet; secretary and assistant treasurer, Seth E. Thomas, Jr.; treasurer, Seth Thomas.

The settlement of the estate of Edward Thomas, a son of Seth Thomas, has recently been completed at the Plymouth Probate Court. Since 1862 the Probate Court has been moved from its original home at the former center to Terryville, and the land belonging to the estate now lies within the limits of the probate district of Thomaston, which has been in existence for 33 years. A life estate was given to the widow, who died a few weeks ago. Her property passed to members of the Thomas family. Edward Canfield, of Hartford, acted as administrator.

A jury in the civil section of the Supreme Court in Bridgeport, Feb. 12, vindicated Col. N. Burton Rogers, of Danbury, in the suit brought against him by Mrs. Grace Hampson, executrix of the estate of her father, Chas. Heedy, who died after in-

juries sustained following a collision between his vehicle and Mr. Rogers' automobile. After the accident Mr. Rogers sent money to Mrs. Heedy, and this led to negotiations for a settlement, members of the family, it is alleged, believing that Mr. Rogers had thus admitted his liability. This matter was brought up at the trial, and the defendant said that he forwarded the money simply with the intention of doing a kind act and not because he felt obligated or liable in any manner.

Lancaster, Pa.

Charles A. Walters has gone to New York and Albany on a two weeks' trip.

Most of the local jewelers last week made very attractive displays for Valentine season.

Robert V. Wallis, a local watchmaker, and Miss Lillian L. Witmer were married Thursday.

John J. Bowman, of Ezra F. Bowman's Sons, visited Philadelphia and Norristown, Pa., last week.

Martin Gutwold, a watchmaker, of Des Moines, Ia., formerly of Lancaster, is paying his first visit to this city in 15 years.

Mr. Erlich, of Erlich & Co., made his first visit to Lancaster last week since engaging in business for himself in New York.

A. H. Rosenstein, president of the Lancaster Silver Plate Co., has been visiting New York, where his representative, S. Hallendale, was also.

A message from Albuquerque, N. Mex., says that Frank A. Paulsen, who went there for his health six weeks ago, is dangerously ill, having suffered a relapse of his lung trouble.

Archibald McRae, a Glasgow, Scotland, manufacturing jeweler, was a visitor to Lancaster last week, having come here principally to see the plant of the local watch company.

Wendell Swartz, York, Pa., has entered the Ezra F. Bowman Technical School as a student in watchmaking. George Folsheimer, a student, has gone to his home in Shrewsbury, Pa., ill.

Charles D. Rood's fine double team, with a hooded sleigh of novel design, attracted considerable attention during the recent period of sleighing, when Lancaster's many crack teams were out.

Donald C. McIntyre has gone to Salt Lake City to take a position as salesman with the manufacturing jewelry firm of which his brother is a member. He took with him his bride, formerly Miss Henrietta McComsey, to whom he was married Feb. 11.

Last Thursday there was sold at public sale a lot of jewelers' supplies and tools which had been held by the People's Trust Co., of Lancaster, as collateral security for L. C. Reisner, a former manufacturing jeweler. They were purchased for \$400 by W. H. Keller.

At the annual meeting held last week, the stockholders of the Hamilton Watch Co. approved the proposed increase of the capital stock from \$500,000 to \$1,000,000. The following directors were elected: Charles D. Rood, J. W. B. Bausman, P. T. Watt, Charles F. Miller and J. Fred. Seuer. During the past three years the company

has been paying annual dividends of about 60 per cent. on its stock.

Cleveland.

Geo. Lightman, formerly head clerk with David Eaffy & Co., 2 Colonial Arcade, is no longer connected with that house.

Mrs. Frederika Krueger, for more than 50 years a resident of Cleveland, who died last week at the age of 80, was the widow of Louis Krueger, a jeweler, who died nine years ago.

Representative Weidman, of the Hamilton Watch Co., was in the city last week. He says he has been a missionary so long that he has earned the title "pastor emeritus" of the Lancaster flock.

The Webb C. Ball Watch Co. has been displaying in the windows of its retail store a silver porringer made by Paul Revere, the jeweler-patriot. It is the property of P. R. Poe, of this city, and bears the old silversmith's name, "P. Revere," on the handle, as well as in the bowl.

Frank Gerstein, wholesale and retail dealer in diamonds, jewelry and musical instruments, now at 2400 Ontario St., has leased more comfortable and commodious quarters at 2215 Ontario St., the store formerly occupied by N. Miller & Co., and expects to be settled in his new home about March 1.

The Wholesale Merchants' Board of the Chamber of Commerce is sending out literature announcing a series of excursions to all retailers in the territory within 200 miles surrounding and offering fare and one-third for the round trip to Cleveland and return. Local jobbers participating are the Bowler & Burdick Co., the Webb C. Ball Watch Co., the Scribner & Loehr Co. and the Sigler Bros. Co. Further particulars may be had by addressing any one of these houses.

A daring attempt to rob the jewelry store of Henry Welf, 1321 Euclid Ave., was frustrated last week, when Mrs. P. Titus grabbed an unidentified man by the feet just as he was crawling in through a broken plate glass window. Mrs. Titus, who conducts a millinery store in the same block, heard a crash of glass about 11 p. m. and ran out just in time to see the window-smasher making for the interior of the place. Catching hold of his feet and pulling with all her strength, she dragged him out, somewhat cut up by the broken glass. He escaped.

That the much-advertised French scientist who has claimed to have discovered a process for making diamonds is not the only worker in his chosen field is indicated by the dispatch from the Ohio town of Wapakoneta, which stated that on the affidavit of his brother, Harpele Buffenbarger, a well-to-do farmer of this county, was subjected to examination and found insane. Buffenbarger's peculiar hallucination is that he can manufacture diamonds from all sorts of odds and ends by merely enclosing them in an old can and starting up a hot fire underneath the apparatus.

F. M. Schouwailer, Red Wing, Minn., has purchased the jewelry business of C. L. Ekberg, of that place. Mr. Ekberg is fitting up an optical office.

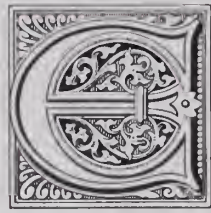

GNTERPRISING and successful jewelers everywhere are pushing the sale of some individual line of watches which they believe to be superior to all others, and upon which they can also make a satisfactory and justifiable profit.

This explains the growing demand for ILLINOIS WATCHES, in 0, 12, 16 and 18 sizes, by increasing numbers of leading jewelers throughout the United States.

If you are not familiar with the superior quality of—and advantages gained by handling—Illinois Watches, it will mean reputation and dollars for you to investigate.

Every one fully guaranteed.

Price List sent on application.

ILLINOIS WATCH COMPANY

SPRINGFIELD

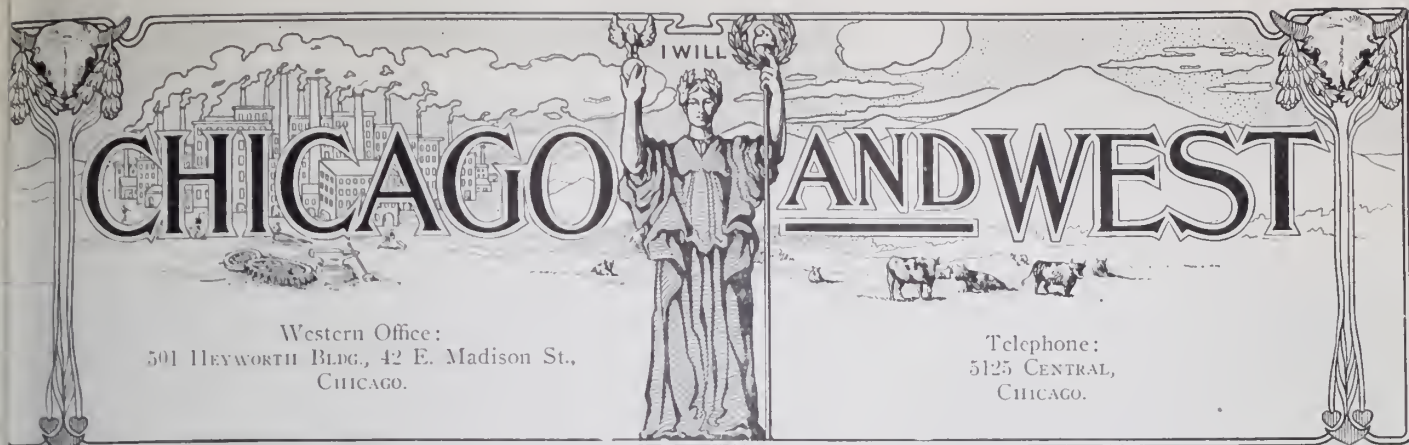

Western Office:
501 HEYWORTH BLDG., 42 E. Madison St.,
CHICAGO.

Telephone:
5125 CENTRAL,
CHICAGO.

VOL. LVI.

CHICAGO, WEDNESDAY, FEBRUARY 19, 1908.

No. 3.

Chicago Notes.

C. C. Hoefler, Kansas City, was here last week.

Henry F. Cohen is on a trip through Wisconsin.

Louis Manheimer is on a three weeks' trip to New York.

E. A. Moore has returned from a trip to the Pacific Coast.

Harry Adler, of Chas. Adler's Sons, visited the local trade last week.

Frank Smith, of Frank Smith & Son, Pontiac, Ill., was in last week.

O. A. Starke, of the Star Watch Case Co., was in New York last week.

Fred Hyatt is on a trip to the Philadelphia Watch Case Co.'s factory.

Fred Rusch, 120 Oak St., announces that he will retire from business May 1.

The case of Giovanni Faraco has been referred to Referee in Bankruptcy Wean.

Edward C. Zimmermann, La Salle, Ill., was among the visitors here last week.

"Jack" Bitterman, of Bitterman Bros., Evansville, Ind., was among the buyers here last week.

Julius Armbruster, of the Illinois Watch Co., spent a few days here last week in the interests of his company.

Albert M. Dueber, of the Dueber-Hampden companies, accompanied by his wife, spent three days here last week.

G. N. Allen, manager of the silverware factory of the Oneida Community, Ltd., was here last week on special business.

Samuel Prager, Terre Haute, Ind., who was here last week, announces that he will hold an auction sale in that town.

Alex. Block, 192½ S. Clark St., has discontinued business at that address. He intends to open in a new location.

Benj. Allen & Co. have sued Benj. Libman, 473 Ogden Ave., for \$74, and Joe Lupo & Co., 147 Grand Ave., for \$150.

C. M. Robertson, wholesale jeweler, who went into bankruptcy some time ago, served on the jury last week before Judge Heap.

Kwate & Kulk, retail jewelers at 3350 S. State St., have been succeeded by M. Kwate, who bought out his partner's interests.

Chas. A. Garlick, representing Reeves & Browne and C. F. Wood Co., stopped over in this city, last week, for a few days on his way west.

Daniel Webster Douglas will represent the Dueber-Hampden companies in Chicago for the next three months, taking the place

of "Tony" Serewicz, who is going to Europe.

H. M. Heyman, formerly with L. Adler & Son, is now representing the S. Cottle Co., Chas. A. Becker Co., Gus Gnam and the Wm. Burke Co.

A. M. Keasey has been engaged by the Quaker City Cut Glass Co. to travel for this house in the middle west. Mr. Keasey left for his initial trip last Sunday.

C. P. Dungan and J. K. Caldwell, of the International Silver Co., entertained a distinguished party of friends on Lincoln's Birthday at the new Star and Garter Theater.

Ben. Frease, a cousin of Mr. Frease, of Frease & Allen, Napoleon, O., who formerly was employed by that firm, has taken a position in the watch department of Benj. Allen & Co.

Wm. A. Rogers, Ltd., has begun suit against the Madsen-Steele Co., the Masonic Temple mail-order house, who asked for an extension last week. The amount involved is \$200.

Claud M. Wheeler, a prominent retail jeweler of Columbia, Mo., and first vice-president of the Missouri Retail Jewelers' Association, spent a few days in this city last week buying stock.

John C. Woelfle, Peoria, Ill., one of the oldest and best-known jewelers in the State of Illinois, was a visitor here last week. Mr. Woelfle has been a subscriber to THE CIRCULAR-WEEKLY since 1871.

Oscar May, J. T. Malone and Emil Schmidt are guests of S. H. Hess, of Rettig, Hess & Madsen at the 12th annual banquet of the Chicago Credit Men's Association, to be held at the Auditorium to-night.

R. F. Prochnow, of the Fort Dearborn Watch & Clock Co., left for Hot Springs last week, accompanied by his wife. On his way home Mr. Prochnow will go on a shooting trip in the Ozark Mountains.

W. J. Adams, Billings, Mont., met a "friend" here last week and was induced to witness a game of pool. Incidentally the "friend" borrowed some money and a diamond stud from Mr. Adams and disappeared.

It was claimed that the Excelsior Watch Co., recently incorporated under that name, may have to meet a trade-mark right to that title on watches of the New York Standard Watch Co. to that name. The latter company has made a watch with that name for many years.

The father of L. E. Fay died last week

at an advanced age. L. E. Fay represents the R. F. Simmons Co. A wire reached him at Los Angeles, Cal., where he was on a business trip, and he returned last week. The remains of Mr. Fay, Sr., will be taken east for interment.

Claude Seymour, chairman; Ernest M. Lunt, J. K. Caldwell and A. W. Sproehnie were a committee of the Chicago Association of Commerce appointed last week to secure subscriptions for the relief of the needy. About \$2,000 is expected to be received in the jewelry trade.

Franz Eschenburg has left for St. Paul, Minn., where he enters upon his new duties with E. A. Brown Co. Just before his departure Mr. Eschenburg announced that E. A. Brown Co. was awarded the contract for furnishing the silver service for the United States battleship *Minneapolis*.

Ben Roth, a retail jeweler at 204 State St., and H. Schwartz, 72 E. Madison St., bought the remaining stock of jewelry of Morsman & Feagans, St. Paul, Minn., last week, paying \$10,500 for it. Mr. Roth bought out Mr. Schwartz's interest, giving him a bonus of \$1,000, and will shortly hold an auction sale.

Chas. G. Breitenbach & Co., wholesale dealers in silverware, have entered suit against Sigmund Ascher, retail jeweler, at 44 Milwaukee Ave., for \$150. Ascher recently sought to compromise with his creditors at 50 cents on the dollar, as previously reported in THE CIRCULAR-WEEKLY. Mr. Breitenbach claims that Ascher received a consignment of silverware on memorandum and refused to return the unsold pieces.

Word was received from Des Moines, Ia., last week, to the effect that N. N. Nolan, who claims to be a traveling salesman for a local jewelry house, has brought suit against the Des Moines Union Railroad for \$15,000 damages for illegal imprisonment. He declares he was arrested without cause at the Union Station, Feb. 10, by a special officer of the company, and was discharged the following morning after spending the night in jail.

P. R. Lawyer, Berkeley Springs, W. Va., has been awarded the contract to supply a town clock, to be placed in the tower of the new court house at Martinsburg, W. Va. The clock will be furnished by the E. Howard Clock Co. and will have four dials, each four feet in diameter. It will strike the hour and will be illuminated after dark.

THE LETTER UNDER THE PICTURE TELLS THE STORY



STORE OF M. E. NABSTEDT & SONS CO., Inc., DAVENPORT, IOWA.

THE ARNSTINE BROS. COMPANY, CLEVELAND, OHIO:

(COPY OF LETTER.)

DAVENPORT, Iowa, January 21, 1908.

GENTLEMEN—As per your request of our opinion regarding the results of the Catalogues you furnished us last Fall, we will say that we have had, comparatively speaking, better results from these splendid advertisements than any previous year, owing to that the first part of November, the money crisis came up, and the local banks issued their clearing house certificates.

We certainly felt that if the Catalogues would do the work as we expected, that we would still do a satisfactory business. After the close of the Holiday Season, in checking up our books for the month of December, we find that we have run considerable ahead over the same month in 1906.

It certainly is very gratifying and speaks volumes for the good work your Catalogue has done for us. We can state that your last Catalogues were admired by all recipients, and it was certainly a beautiful book as any we have seen anywhere in the country. We only regret that we did not have ten thousand copies instead of three thousand. We wish you a profitable and successful year. We remain, with kindest regards,

J.M.N./C.S.B.

Yours very truly,

M. E. NABSTEDT & SONS CO.,

J. M. NABSTEDT.

THE ABOVE FIRM FIRST USED OUR CATALOGS IN 1902.

At a moderate cost, we make it possible for every Retail Jeweler to have a Catalog of his own, that will be appreciated by his customers, a credit to himself, and make his store the leading one of its kind in his community.

WRITE FOR INFORMATION

THE ARNSTINE BROS. COMPANY

Makers of Catalogs for Retail Jewelers only

CLEVELAND, OHIO

Indianapolis.

A business trip through Illinois is being made, this week, by A. P. Craft, head of the A. P. Craft Co.

After a severe illness of several days, J. E. Reagan, manager of the Baldwin, Miller Co., is again able to attend to business.

Horace A. Comstock is attending the National Bowling Tournament at Cincinnati, as a member of one of the local teams.

Samuel Drozdowitz has consolidated the jewelry stock he carried at 146 E. Washington St. with that of his new store at 259 E. Washington St.

N. W. Myer, Crawfordsville; F. C. Sheldon, Shelbyville; J. W. Hudson, Fortville, and A. S. Orr, Greenfield, were among Indiana retail jewelers, in this city, last week.

Local dealers state that the Valentine Day business this year exceeded that of any previous years and that jewelry and silver are becoming more and more popular as valentine gifts.

J. Burke, L. Swantzberg and R. Burke organized and incorporated J. Burke & Co. at South Bend, last week, with \$7,000 capital. They will manufacture a general line of spectacles and optical goods.

Jacob Strauss, of Jacob Strauss & Sons, New York, was in this city, last week. While here he took occasion to deny the rumors that diamonds are to decrease in price and he was quoted extensively by a local newspaper.

The retail business of Chris. Bernloehr & Bros. was incorporated last week, with a capital of \$10,000. They have been in business several years and are now located on the second floor at 14-16 E. Washington St. Members of the firm are Chris., J. A. and A. B. Bernloehr.

The annual meeting of the Indiana State Optical Society was held at the Denison Hotel, in this city, Monday of last week. The programme, as previously announced, was carried out with the addition of an illustrated lecture by David Bixler, showing the action of light when using the retinoscope and a talk on "Some Experiences of the State Board of Optometry," by J. H. Ellis. A banquet at the Grand Hotel, in the evening, closed the meeting.

St. Louis.

C. E. Oeth, Jefferson City, Mo., came to this city last week to claim his 13-year-old daughter, Lillian, who was with her mother in this city. The Oeths have been separated and the girl was in her mother's charge.

Morris Eisenstadt, president of the Eisenstadt Mfg. Co., is among the projectors of the newly organized Westwood Club, a golf and country club, composed of members of the fashionable Columbian Club, which has closed a lease on a magnificent country estate, near Kirkwood, west of St. Louis.

August J. Wedrunsky was arrested last week in a pawnshop, and when searched at headquarters eight watches, several rings and a number of valuable pins were found on him. The jewelry, as well as the clothing worn by the prisoner, was identified by A. H. Soltz, a jeweler, of 1909 Market St.

The organization was completed last week at Little Rock, Ark., of the Arkansas Jew-

elers' Association. The preliminary steps were taken when 50 jewelers met, E. A. Short, of Prescott, presiding, and adopted a constitution and by-laws. The first annual convention will be held Aug. 25, at Hot Springs.

John Hasey has been arrested on suspicion of being implicated in the robbery of the H. Rembold Optical Co., 512 Pine St., on the night of Oct. 22 last. The Rembold firm was robbed of two cameras, money and photo apparatus valued at \$100. Fountain pens and photographic apparatus identified as the property of the company were found in the suspect's room. Pawn tickets for a camera and field glasses were also found there.

Cincinnati.

Sol. Fox, of Fox Bros. & Co., and his wife, are visiting their daughter, Mrs. Judge Mack, of Chicago.

A. A. Spiegel, of A. A. Spiegel & Co., with his family is spending a week visiting his parents in Chicago.

Oscar Keck, of the Herman Keck Mfg. Co., is at his desk again, after an illness of several weeks with grippe.

D. Carl Oberholtzer, Centerburg, O., is here taking engraving lessons of A. C. Geiger, with the Clemens-Oskamp Co.

Hugo Lindenberg, of Lindenberg & Fox, is making his southern trip, and C. G. Goldsmith, of this house, is on a western tour.

A. & J. Plaut, last week, exhibited in their window the large solid silver vase and 12 solid gold jeweled medals, won by Mrs. M. C. Howell, of the National Archery Association.

The local association of wholesale jewelers and manufacturers held a regular meeting Feb. 13 at the Sinton Hotel, when the members adopted a new constitution and by-laws.

Harry C. Walton and Charles Becker, local managers for the Keystone, Crescent and Philadelphia Watch Case companies, have left for a few days' stay in Riverside, N. J., and Philadelphia, Pa.

Charles Melcher, formerly with Aikin-Lambert & Co., has become associated with the John Holland Gold Pen Co. as traveling salesman. His territory will be in the south and he will start on his first trip this month.

The local association of retail jewelers held a regular meeting Feb. 11 at the Palace Hotel, when preliminary arrangements were made for the convention of the American National Retail Jewelers' Association, to be held next August.

Local pawnbrokers have formed an organization, the purpose being to take action against the Stockwell bill in the Ohio Legislature. The bill provides that pawnbrokers may not charge more than 2 per cent. on loans of \$50 or less. At present there is a charge of 10 per cent. The organization has sent representatives to Columbus, O., to lobby against this measure.

Out-of-town jewelers here during the past week buying stock included: A. P. Humphreys, Bellefontaine, O.; E. F. Starks, Newport, Ind.; A. M. Stamm, Williamsburg, O.; Chris. Hewig, Evansville, Ind.; Mr. Dougherty, Bethel, O.; C. H. Creighton, Morrow, O.; W. Levinson, Columbus, O.; A. C. Beckley, Thurmond, W. Va.; O.

Harris, Rising Sun, Ind.; F. Borgering, Lawrenceburg, Ind.; William J. Burkhardt, Dayton, O.; W. A. Fisher, Fairmount, W. Va.

Detroit.

F. H. Nissley, Saline, was in the city purchasing silver last week.

The Weyhing Bros. Mfg. Co. has finished installing its new die-cutting plant.

J. Wollstein, of the firm of L. & M. Wollstein, New York, was in this city last week on a purchasing trip.

Eugene Campbell and wife, Pinckney, were in this city a few days ago, Mr. Pinckney visiting the wholesale houses.

George Chambers, of the firm of the Chambers & Stewart Co., Mt. Clemens, has gone to Florida for the remainder of the winter.

W. W. Bridges, Marine City, has gone to Oklahoma for a few weeks. He has placed his store in charge of Wm. Ulrich, formerly in business in Detroit.

J. F. Plimley, formerly a manufacturer here, but who went to California on account of failing health, writes to friends in the trade that he is recovering.

Edward H. Sauer, Three Rivers, has lately renovated his store. Besides putting in new fittings he has had steel ceilings put in, reducing the risk of fire.

Benjamin Staley, who has been watchmaker for the E. J. Berthet Co., has taken a position in Indianapolis. His place is taken by Robert Taylor, formerly with Joseph H. Ehrlich.

Wm. J. Schultz, jewelry manufacturer, was among the money winners in the American Bowling Congress tournament at Cincinnati, scoring 617 in three games in the individual matches. His team, the Herculeans, was also well up in the tourney, falling just outside the first 10.

Elias D. Trebilcock, 324 Woodward Ave., has sold out to George Schaffner, who has been in the repairing and smelting line in the Loyal Guard building for some time, but who was formerly a retail jeweler. The Trebilcock store was formerly conducted under the firm name of Trebilcock Bros.

A shrewd trick, new to Detroit jewelers, was worked recently at the store of the Luths, Dorweld, Haller Co. The sharper visited the place first to look at some goods near the repair counter and later sent in a messenger, who called for an expensive watch hanging on the repair board, giving the correct name and make. The watch was turned over, but the swindle was discovered later, and a search disclosed the watch in a pawn shop. Some days later Detectives High and Larkins arrested a man in the shop who was trying to pawn a fine grip, and he was identified as the man who had pawned the watch and also who had visited the Luths, Dorweld, Haller Co.'s store and glanced over the repair board. He gave his name as Edward Davis when brought up in police court on a charge of larceny. As the money loss was promptly repaid by him the justice suspended sentence. Jewelers have an idea that this man may be a professional working this trick regularly. He is described as middle-aged, tall and of slender build and slightly gray.

THE HOME OF THE CELEBRATED CARMEN BRACELET



The D. F. Briggs Co.
Attleboro Mass.

A Wonderful Discovery in Jewelry!!

HAT PINS MADE FROM GENUINE ROSEBUDS

Fresh cut rosebuds are placed in a solution which deposits a coat of metal on the buds. The form, with the delicate veins and tracings of the leaves, is retained.

AS IN
NATURE
NO TWO
ARE ALIKE

—
ROSE GOLD
FINISH

—
SOLD ONLY
TO
RETAIL
JEWELERS



THESE
HAT PINS
CAN BE
RETAILED
AT FROM
\$2.00
TO
\$5.00
WHEN
IT IS
EXPLAINED
WHAT
THEY ARE

HAT PINS, C-656, PER DOZEN, \$12.00 NET.

SEND ORDERS TO

LAPP & FLERSHEIM, Wholesale Jewelers, CHICAGO, ILL.

Kansas City.

Guy A. Esslinger, who has been ill with a gripe, is again able to be at the store. H. C. Kionka, of New York, has been giving a visit to his brothers, C. P. and E. Kionka, of Kionka & Kionka.

C. B. Norton, president of the C. B. Norton Jewelry Co., has returned from a visit to the jewelers in the Joplin district.

H. F. Wells, representing the Woodstock-Hoefler Watch & Jewelry Co. in Iowa, reported to be ill at his home in that state.

Ada M. Kessimer, with the C. B. Norton Jewelry Co., is the author of a neat little book of verse which has just been published.

F. C. Clemant, who has just purchased a store of Dick Kolstead, Pleasant Hill, Mo., has been in the city buying some additional goods.

Leslie Burklund has resigned his position with the Meyer Jewelry Co., and will leave the road, taking a position with his old friend, Otto Burklund, Moberly, Mo.

W. E. Crellin, of the Ward & Crellin Jewelry Co., and Leslie White, with the same company, left for another trip over their respective territories last week.

The following new pupils have enrolled in the Kansas City Polytechnic Institute:

McClushey, Nelson, Nebr.; Alex. Bardi, Kansas City, and L. Herwitz, Kansas City. W. C. Vandel, who covers Missouri, Iowa and Arkansas for the Edwards & Doane Jewelry Co., has been paying the house a visit this week, but is again in his territory.

E. H. Morgan, of the C. B. Norton Jewelry Co., has just returned from a trip to Texas, where he has been calling on the trade in company with the regular representative.

Charles Cleveland, a traveling representative for the Woodstock-Hoefler Watch & Jewelry Co., was married, Feb. 5, to Miss Olga Mensing, Olathe, Kans. The couple will make their home in Olathe.

The C. B. Norton Jewelry Co. lost a valuable diamond pin the early part of last week. A man representing himself to be a peopeka jeweler called and asked to look at some diamonds. He bought nothing, but when he left the store the pin was missing. The man has not yet been located.

The following out-of-town jewelers visited this market during the past week: J. R. Delaplain, Helena, Ark.; Mr. Arnold, of Arnold & Co., Texarkana, Ark.; J. J. Baker, Moline, Kans.; W. W. Whiteside, Liberty, Mo.; J. W. Talbot, Nevada, Mo.; Rummel, Paris, Tex.; Wm. H. Meyer, Dawson, Mo.; W. H. Hoover, St. George, Kans.; G. Schueth, Humphrey, Nebr.; H. Sutton, McCook, Nebr.; L. E. DeLanty, Arkville, Mo.

Milwaukee.

Charles W. Nebel, graduate of the Northern Illinois College of Ophthalmology and Optology, has opened optical parlors at 495 24th St., in Milwaukee. He was associated with A. Reinhard, optician, for several years.

Pending a more thorough investigation, the Milwaukee Jewelers' Club has again postponed definite action on the fraternal

or co-operative burglary insurance project, and at the monthly dinner it was decided to begin working toward a definite end at the March meeting. The February meeting at the Blatz Hotel was spent in discussing the insurance question, trade topics, the State convention of jewelers and entertainment. The time of the monthly dinner was changed from 7.30 o'clock p. m. on the second Wednesday to 7 o'clock. Although no committees have been appointed to look after the arrangements for the State convention, the Milwaukee Jewelers' Club as a body is making plans for entertainment. The feature originated by Secretary Franklin Thomson, to give the women more prominence in State conventions, has been taken up enthusiastically.

Pacific Coast Notes.

Niels Nielsen, Salinas, Cal., has moved into new quarters.

F. P. Sieglitz, Rhyolite, Nev., last week moved his stock into a new store.

The interests of Paul W. Stecher, Ogden, Utah, are to be taken over by a new company.

H. A. King, Eureka, Cal., has leased a new location, into which he will soon mail his stock.

E. H. Smith, Orange, Cal., is moving into temporary quarters pending the completion of his new store.

The first woman shoplifter caught in Goldfield, Nev., was detected last week trying to remove articles from the store of Doane & Rosenthal.

W. E. Richter, of the Hickox-Maynard Co., Albuquerque, N. Mex., has applied for a patent on an electric time-switch device, which he has invented.

G. Reber, Petaluma, Cal., who was arrested here last week on a minor charge, has been discharged, the case against him having been dismissed.

Manson & Bay, Redlands and San Bernardino, Cal., have dissolved partnership, A. C. Bay taking the Redlands store and W. A. Munson keeping that in San Bernardino.

F. Backstein, Clifton, Ariz., had his plate glass window broken by unknown parties twice within the last few months. He has offered a reward for the arrest of the offender.

Two men, giving the names of Ed. Croll and Ed. Howard, respectively, have been arrested in Stockton, Cal., on a charge of peddling worthless rings, which they sold as gold.

Eugene Maube, at one time prominent in the Oakland trade, is confined in the Oakland jail, closely watched to prevent him from taking his life. He was recently charged with embezzlement for pawning a watch left with him for repairs, and on hearing of the charge attempted suicide by drinking wood alcohol.

The Fisher & Bellows Co. has sold its stock in Roseburg, Ore., to Rostein, Greenbaum & Co.

In a recent fire in Bennettsville, S. C., the store of S. J. Pearce was damaged to the extent of \$3,000. The insurance amounted to \$1,000.

Omaha.

L. Borsheim is at Hot Springs, Ark., for a couple of weeks.

Chas. Krause, Randolph, Nebr., spent a few days of last week in this city.

C. A. Huck, Schuyler, Nebr., was in this city last week, replenishing his stock.

L. F. Boyce, with Albert Edholm, is confined to his home on account of illness.

Oscar J. Hoberg, Sioux City, Ia., is in the city attending the Whist Tournament.

Isadore Gottheimer, formerly with A. Mandelberg, has taken a position with the Bennett Co.

S. W. Lindsay has secured a new lease on the building which he has occupied for the past 21 years.

Miss Evelyn Bergman, daughter of Sol. Bergman, is home from a three months' visit in New York and the east.

Fred Brodegaard, one of the leading jewelers of this city, was recently elected president of the Suburban Improvement Club.

E. W. Keating, formerly of this city, now representing Swartchild & Co., Chicago, paid a visit to this city last week.

Joseph P. Frenzer supplied the handsome diamond necklace valued at \$3,000 which was presented by a prominent resident of this city to his bride on the occasion of his recent marriage.

On Dec. 17, 1907, several mail sacks which were in the baggage room of the Missouri Pacific Railway were taken out and rifled. Last week at Nebraska City Joe Jones, a negro who has been about the city for the past two years, offered a valuable ring to a jeweler who at once recognized it as one of the rings he had sold and which was in the mail that went out that night. The police were at once notified and the negro was arrested. The mail boxes and sacks have been robbed twice, and no clue was obtained until this ring turned up. The officers now believe they will be able to arrest the entire gang and recover the stolen property.

The jewelry store of Louis Borsheim, 506 S. 16th St., was broken into by burglars Sunday morning, Feb. 9, and looted of several hundred dollars' worth of stock. Entrance was gained through a rear door, which is made of sheet iron. The robbers made their haul some time after 4 o'clock in the morning, as a watchman found all well at that hour. Mr. Borsheim came down at 3.30 o'clock Sunday afternoon and discovered the burglary. The articles stolen were 21 dozen silver knives, forks and spoons, five mirror sets, a dozen pearl-handled gold pens, 25 fountain pens, a number of manicure sets, several watches, bracelets and small valuables, amounting to about \$350. The police are working on the case.

Pacific Northwest

C. T. Dingenpeel is moving from Marysville, Wash., to Arlington, Wash.

C. Christesen, Portland, Ore., is preparing to open a new store, and is having attractive furniture and fixtures specially designed.

Herman I. Segerstrom, Wallace, Idaho, has begun voluntary bankruptcy proceedings. His liabilities are about \$6,000, with assets of \$3,500.

LEATHER BRACELETS FOR WATCHES

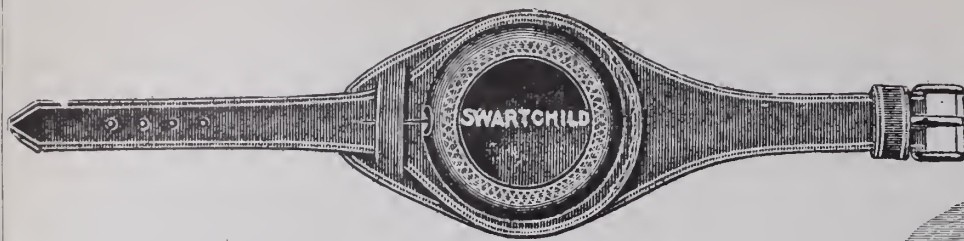

No. D 10. Best quality leather, each, \$0.40; per dozen, \$4.50

Extra Fine Selected
CUTTLEFISH BONE
for forming ring moulds, etc.

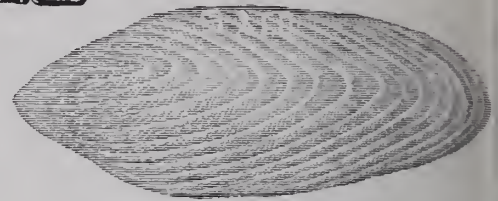

Each piece 6 to 7½ inches long
Price per dozen pieces, . \$0.75

SWARTCHILD & COMPANY

Heyworth Building, CHICAGO

The Largest Exclusive Jewelers' Supply House in the World

If you have not a copy of our double sized 440 page Catalogue write at once.
Sent gratis upon application.

AARON COEN, Pres.

H. J. SEILER, Vice-Pres.

RALPH WAKEFIELD, Treas.

WAKEFIELD & SEILER CO., Inc.

Makers of Fine Jewelry

109 OLIVER STREET

NEWARK, N. J.

THE LATEST IN SCARABEE JEWELRY

Scarabee stones mounted in scarf-pins, brooches and link buttons. All genuine stones in the following shades—Jade, Amazonite, Malachite, Amethyst, Cornelian, Bloodstone and Green Sardonyx. These are beetles cut in stone and are also used as birth stones. The beetle is the symbol of good luck used by the ancient Egyptians and is becoming very popular. They will be more in vogue than the Swastika emblem was. They are made up in 10 Kt. gold to sell from \$2.00 to \$3.50 to the public.

We are also making a line of gold mounted combs different from the every-day comb in the market to-day.

We are the cheapest concern in the country on seamless tube jointed bracelets by weight; we also supply the manufacturing trade with seamless tubing used for bracelets and joints.

REMEMBER US AND WRITE US—the new house with the new ideas. 10 Kt. goods with the 18 Kt. finish.

We make a specialty of seamless tube bracelets in flat, oval, round and square.

HERMAN KOHLBUSCH, Sr.,

ESTABLISHED 1859.

Manufacturer of Fine Balances and Weights

for every purpose where accuracy is required.

Office and Salesroom, 194 BROADWAY, NEW YORK.

Send for Price List.

Tel. 370 Cortlandt.



Don't Worry About the Scarcity of Money

If you need any send us your surplus stock of Diamonds, Watches, Jewelry, Old Gold and Silver, and get our certified check by return mail. If amount is not satisfactory goods will be returned in same condition as received. Strictly confidential Correspond or call. Telephone, 5262 John

New York Jewelry Purchasing Co.

106 Fulton Street, New York



J. E. ROHRBECK
MANUFACTURER
40 FULTON ST.
NEW YORK, N.Y.

IF IT'S A

ROY

TRADE MARK REGISTERED

IT'S STANDARD

On March 1st, ask your jobber to show you the Ægis Gold Watch Case. Made in 12s and 16s Open Face, Bassine plain, and Jurgensen engine-turned.

A new creation in gold case making.



ROY WATCH CASE CO.

21-23 Maiden Lane, New York City

SAN FRANCISCO, CAL.

LONDON, ENG.

Trade-Marks of the Jewelry and Kindred Trades. Second Edition. Price, \$3.00. The Jewelers' Circular Publishing Co.

Los Angeles.

R. A. Moore, Santa Barbara, was here a few days ago.

Bernhard Olcovich moved a few days ago from 713 to 711 S. Broadway.

E. Gerson will have an optical department in his new store at 545 S. Broadway, with a first-class optician in charge.

Albert Ganter, a German jeweler who has been doing business at 621½ W. 6th St., has discontinued business at that place.

J. A. Codori, a Los Angeles auctioneer, is selling the bankrupt stock of E. D. Grandmason, at Ocean Park, under the direction of Trustee Bailey.

The Western Gem Co., F. Stansfield, manager, will move about March 1 from 27 S. Broadway to 410 W. 7th St., where a large new shop is being prepared for use.

A recent cable message from H. J. Whitney, now in Europe, announces that he has decided to continue his trip to and through Egypt and the Holy Land. He will not, therefore, be home as soon as was expected.

Miss Ruggles, a young saleswoman in the employ of J. C. Fleming Co., was robbed a few days ago of a gold watch bearing a diamond in the case, while in a crowded department store. There is no clue to the identity of the robber.

D. M. Small, who has been for some months past manager of the jewelry department in Bullock's general store, has resigned and resumed his old position with Montgomery Bros. His place at Bullock's has been taken by Percy G. Winnett.

James G. Picou and James W. Crogan have entered into a contract with Janes & Co., by which they lease this company's jewelry manufacturing plant, with the privilege of buying it after a stated period. Mr. Picou has been acting foreman of the shop for some time past. Mr. Crogan was also an employe of Janes & Co.

The store of M. W. Barber, 513 W. 6th St., was entered by a burglar about 10 P. M. a few days ago. He forced an entrance through the rear and was at work in the store when he was heard by a woman occupying a room near by. The police were summoned by telephone, but before an officer arrived some one turned on the electric light in front of the store. This frightened the burglar and he escaped by the way in which he entered. The doors to the show cases in front were found open, but so far as Mr. Barber has been able to discover no goods were taken.

Sidney E. Ash, an employe in the manufacturing department of the Carl Entemann Jewelry Co., was arrested and found guilty of embezzlement last week and sentenced to pay a fine of \$150 or serve 150 days in jail. Ash is married and 35 years of age. He had been in the employ of this company since 1901. Another employe observed him putting in his pocket gold that had been given him for use at his bench and reported the fact to Mr. Entemann. He was then watched and was seen to place several pieces of gold in his pocket. A detective was summoned. Ash was brought into the business office and accused of the crime. He at first denied his guilt, but when the detective told him that he knew just what he had taken and where it was concealed he confessed that he had taken a single piece, which he produced and gave

to Mr. Entemann. Further pressure upon him led him to confess more thefts, and gold amounting to 18¾ pennyweights was recovered. It is believed that he had been systematically stealing from his employers for probably several years past, but the evidence of this could not be produced. A diamond ring worth \$110 was stolen from the firm some time ago, but no evidence of the identity of the thief has been obtainable. Because Ash was an employe of the company it was necessary to make the charge one of embezzlement. He was tried in court and convicted on this charge.

San Francisco.

Harry Silver, Seattle, Wash., is now in San Francisco.

J. Ikieta, Skagway, Alaska, visited the local trade last week.

Ernest Muller, Eureka, Cal., is visiting the trade in this city.

Alphonse Judis, of the Alphonse Judis Co., is now in New York.

Julius Wise, of J. S. Lehrberger & Co., is visiting relatives in the east.

The fireproof floors are now being put in the Jewelers' building on Post St.

L. Myers, of the R. & L. Myers Co., is spending his honeymoon in southern California.

McGraw & Lazarus, whose store was recently burned, have secured a desirable new location on Montgomery St., near Sutter St., where they will open in a few days.

Mr. Dorrance, of the Dorrance Battin Co., has just returned from a trip to New York. Edson Adams, of the same company, has been spending his honeymoon in Honolulu.

Mr. Davidson, formerly of Davidson & Rothke, Oakland, Cal., will open a store on 3d St., near Market St., in the near future. Mr. Rothke has bought out his share of the Oakland business.

Charles Kingston has been arrested on a charge of stealing about \$100 worth of goods from the valise of Montague Mendoza, a traveling representative of the Van Duzen & Stokes Co., Philadelphia, Pa.

K. Melrose, of the W. K. Vanderslice Co., is a member of a committee appointed by the merchants of this city to get up a fund for the reception of the naval fleet, which is expected about the end of April. Mr. Melrose says that the trade is subscribing liberally to the fund, as the presence of the fleet is expected to be a great stimulus to business.

Minneapolis and St. Paul.

Wm. Krohn, Annandale, Minn., who left last week, for Cuba, contemplates locating there permanently.

Alfred Anderson, who canvasses the lumbering and mining camps in their seasons, has returned to this city after a trip to the Pacific coast.

The E. A. Brown Co., St. Paul, was awarded the contract to supply the silver service for the battleship *Minnesota*. The Reed & Barton Co. will make the service.

Vehon & Goodman, St. Paul, have filed articles of incorporation, with a capital stock of \$50,000, to deal in jewelry. The incorporators are L. H. Vehon, A. D.

Goodman and M. L. Finkelstein, all of whom are associated with the trade in St. Paul.

Among the recent out-of-town jewelers in the Twin Cities were: E. S. Houghton, Brainerd, Minn.; O. E. Oslund, Milaca, Minn.; R. S. Swarthout, Pine Island, Minn.; Peter Weinzierl, Waconia, Minn.; Mr. Holverson, of Baumbach & Holverson, Alexandria, Minn.; A. L. Mealey, Delano, Minn.

Denver.

Mr. Halburt, of the American Optical Co., has been in the city for a few days on his annual western trip.

R. E. Hawkins, of the Edward Lehman Jewelry Co., leaves this week on his Spring trip. He will cover Colorado and all of the northwestern territory.

L. A. Scott, 18 years of age, who claims his parents are wealthy Denver people, is under arrest in Tucson, Ariz., charged with the theft of diamonds valued at \$2,500. The stolen jewels are alleged to have been taken from Mrs. J. F. Sager, of that city. The boy appears to be weak-minded.

While Mr. Hamilton, at one time owner of a jewelry store in the east and now traveling representative for a large manufacturing concern, was out of the city recently, his home at 1541 Steele St. was robbed and jewelry valued at nearly \$1,000 was stolen. Mrs. Joseph Hamilton and her daughter were at the theater when the robbery occurred. The Hamilton family has lived in Denver for more than a year. They came west for Mr. Hamilton's health.

Joseph I. Schwartz announces that Mrs. Frederick H. Wood, against whom the jeweler brought suit for the recovery of \$15 which was alleged to be a balance due as the result of a sale, has paid the costs of the case and the money sued for, and that the litigation has consequently been closed. The defendant had refused to pay the money sued for, which was part of the price of a topaz and gold necklace, alleging some of the stones of the necklace had been altered. The jeweler avers that the purchaser had the necklace made longer and seemed satisfied until the following day, when she returned and said she had decided that she did not want it at all. After having made the requested alterations Mr. Schwartz refused to refund the money, and it is declared that the defendant then alleged that other stones had been substituted for the original ones.

Trans-Atlantic Voyagers.

TO EUROPE.

David Urbach, Keyport, N. J., accompanied by his family, will sail, March 17, on the *Kronprinzessin Cecile*.

Benjamin F. Rees, New York, sailed yesterday on the *Kronprinzessin Cecile*.

Mr. and Mrs. Wm. Barthman, New York, sailed Saturday on the *Hamburg*.

Mr. and Mrs. Joseph Fahys, New York, sailed Saturday on the *Cedric*.

Geo. H. Rosenblatt, New York, sailed yesterday on the *Kronprinzessin Cecile*.

A. Mendelsohn, of Mendelsohn Bros., Boston, Mass., sailed Saturday on the *Kaiserin Auguste Victoria*.



MIDSUMMER
NIGHT'S
DREAM
SERIES No. D287A

"A Midsummer Night's Dream"

is the latest production
of the *Royal Doulton*
factories. Exquisitely
enameled in rich colors.

Sole Agent

W. S. Pitcairn

44 Murray Street
New York

Write for Booklet, "Quaint Bits
of Royal Doulton"



GOLD PLATED Art Jewelry of every description, and the Schickerling patented Elk and Eagle lines. Fine Diamond Mountings.

¶ Makers of fashionable, popular price, ten and fourteen karat Solid Gold Jewelry. Card Holders for all Lodges, solid gold, sterling and plated. Artistic Novelties.

SCHICKERLING MFG. CO.

391-393 Mulberry Street, NEWARK, N. J.

CONRAD SCHICKERLING, Pres.

T. M. SCHROEDER, Treas.

Trade-Marks of the Jewelry and Kindred Trades.

Second Edition. Over 4,000 Marks.

Price, \$3.00.

THE JEWELERS' CIRCULAR PUBLISHING CO., 11 John St., New York.

RECENTLY
PUBLISHED

READY FOR
DELIVERY

Gems and Precious Stones

THEIR

Characteristics, Localities of Production, Tests and Some Current Literature.

A new book on a new plan. Tabulated, concise, authoritative.

A handy manual for every Jeweler.

CONTENTS

CHARACTERISTICS and LOCALITIES of PRECIOUS STONES

Shows in tabulated form the Chemical Composition, Crystallography, Common Fracture, Lustre, Hardness, Color, etc.

TESTS FOR PRECIOUS STONES:

Describes testing implements, methods of testing, mineralogical characteristics, specific gravity, dichroism, tests, etc.

FAMOUS DIAMONDS OF THE WORLD.

SOME FAMOUS DIAMONDS.

BIRTH STONES OF VARIOUS NATIONS.

GEMS FOR THE DAYS OF THE WEEK.

POETRY OF GEMS.

BIRTH STONES AND THEIR SIGNIFICANCE.

SIGNIFICANCE OF SOME GEMS.

BIRTHDAY FLOWERS.

ZODIACAL SIGNS OF FLOWERS.

WEDDING ANNIVERSARIES.

FLOWERS OF THE MONTH.

OFFICIAL FLOWERS OF THE UNITED STATES.

CLOTH, POSTPAID, \$1.00

PUBLISHED BY

The Jewelers' Circular
Publishing Co.

11 John Street - New York



F. P. Coulter, of the South Bend Watch Co., South Bend, Ind., was in Roseburg, Ore., recently. Charles Kuesel, Henry Pitzner and A. L. Heuer started out recently on their respective routes for Wessel Bros. Co., Milwaukee, Wis.

Traveling representatives in Denver, Colo., last week, included: William Barker, R. Wallace & Sons Mfg. Co.; Mr. Adams, Martin-Copeland Co.; J. J. Valentine and Herbert Graham, with A. I. Hall & Son, San Francisco, Cal., have returned on their first Spring trips, and will start out again in a few days.

Among the traveling representatives in San Francisco, Cal., recently, were: A. J. Parker, Osmun-arker Mfg. Co.; A. Rosenberg, Alling & Co.; C. Mann, Sussfeld, Lorsch & Co.

Traveling representatives in Los Angeles, Cal., last week, included: W. C. Sharkey, Perley Bros.; F. Finley, Whiteside & Blank; H. H. Day, Day, Lark & Co.; Mr. Mitchell, Sloan & Co.

Among the traveling representatives who called on the Toronto, Ont., trade, last week, were: Chas. E. Friedrich Speidel (Pforzheim, Germany); George Brabander; George Smith, Theodore W. Foster & Bro. Co.; Mr. Curley, Waltham Watch Co.

The following traveling representatives called on the trade in Kansas City, Mo., during the past week: Mr. Jaskow, Bodenheimer & Jaskow; Mr. Parker, R. Wallace & Sons Mfg. Co.; Mr. Kimball, Frary & Clark Co.; R. B. Eaton, S. Stern & Co.; Mr. Noyes, Bates & Bacon; Mr. Noble, Turvett & Whiting.

Traveling men visiting Boston, Mass., during the week, included: William H. Sparks, Seth Thomas Clock Co.; Alex. C. Chase; Robert Steele, David Barker & Co.; Mr. Bennett, Rockford Watch Co.; G. Magee, C. F. Rump & Sons; Charles E. Hancock, Hancock, Becker & Co.; Arthur H. Schmitt, Wesler Mackenzie Co.; Julius Kaufman, Goodfriend Bros.; C. A. Gallagher, Sinnock & Sherman; John F. Schierloh, Keystone Watch Case Co.; W. Sherwood, Solidarity Watch Case Co.

The following traveling representatives visited the trade in Lancaster, Pa., recently: Frank G. Milnerberger, J. B. Bowden & Co.; C. E. Hunt, Hafer & Douglas; Arthur Abraham, Cohn, Abraham & Co.; M. A. Illingworth, American Silver Co.; Mr. Gray, Schwartz & Gray; Mr. Wolf, Coding & Heilborn Co.; Mr. Adams, Wm. B. Duran Co.; Irwin Irlich, Wolf-Irlich Co.; Alex. Konkner, Edward Todd & Co.; John Battin, Battin & Co.; Ernest Patry, Kremenitz & Co.; W. T. Francis, Waterbury Clock Co.

Among the traveling representatives who called on the Cincinnati, O., trade, during the past week, were: C. F. Hartshorn, Kremenitz & Co.; Charles E. Evans, John R. Keim; H. B. Bliss, Gorham Co.; Thomas B. Burgess, Frank M. Whiting & Co.; E. J. Hoyt, Louis W. Hraba; Thomas E. Rogers, Riker Bros.; H. B. Rogers, Rogers & Co.; E. A. Reed, Reed & Barton; S. E. Bolles, William Heber; Harry Goodison, E. G. Webster & Son; Walter R. Shute, Day, Clark & Co.; D. A. Davidson, Wallach & Davidson; L. H. Smith, Bippart, Riscom & Osborn; M. Lampert, Henry Zimmern & Co.; Mr. Powell, S. O. Bigney & Co.; C. A. Holbrook, Sloan & Co.; William Rosenberger, A. Walsh & Co.; Mr. Sylvia, Pairpoint Corporation; George H. Remington, Maintien Bros. & Elliot.

The following traveling representatives visited Savannah, Ga., recently: John P. King, Theodore F. Foster & Bro. Co.; R. A. Hawkes, J. B. Bowman & Co.; L. H. Wolf, Jr., J. Boesse & Co.; B. Schackner, T. G. Hawkes & Co.; J. Percy Wrayner, Durand & Co.; A. J. Goode, Chapin & Holter Co.; a representative of S. Cottle Co.; a representative of the Newburyport Silver Co.; J. Lambert, P. W. Lambert & Co.; S. Doenitz & J. Swigart Co.; Oscar S. Schmidt, Moore & Son; H. Abraham, Cohn, Abraham & Co.; Mr. West, Pairpoint Corporation; J. Bernheim, Woodde Sterling Co.; Harry C. Birch, Grant Jewelry Co.; a representative of the New England Watch Co.; a representative of Ketcham & McDougall; a

representative of the Tiffany Electric Mfg. Co. and Wilcox & Wagoner Co.

The salesmen of the New England Watch Co. have been on the road for several weeks now, and are hard at it in their respective territories. Following is a list of territories and the salesmen: Benjamin Westervelt, Greater New York; F. Van Olinda, New York State and Pennsylvania; H. I. Bushe, New England States; H. C. Warner, West Virginia, Ohio, Kentucky and Tennessee; H. C. Birch, southern States; W. C. Gretter, New Jersey, Delaware and the south; George T. Lester, Illinois, Indiana and Michigan; D. H. Raymond, Wisconsin, Minnesota, Iowa and the Dakotas; Carl Wolff, Missouri, Kansas and Nebraska; E. W. Holland, Oklahoma, Arkansas and Texas. Burr W. Freer and his corps of assistants are looking after trade in California, Washington, Oregon, Idaho, Nevada, Montana, Wyoming, New Mexico, Arizona, Utah, Colorado and Alaska.

Traveling representatives who called on the trade in Omaha, Nebr., last week, were: F. R. Horton, Carter, Howe & Co.; George Pilzer, Goodfriend Bros.; De Lancy Stone, Shafer & Douglas; Mr. Brinckle, C. F. Monroe Co.; Hubert Somborn, Hipp, Didisheim & Bro.; Eugene De Nike, Charles P. Goldsmith & Co.; Mr. Colyer, McConnell-Colyer Co.; Mr. Lucas, Frank W. Smith Co.; C. A. Weidemann, George Borgfeldt & Co.; Charles E. Eckel, Unger Bros.; C. H. Davidson, Kohn & Co.; W. H. Hamill, Fred Kaufmann & Co.; George F. Heidt, C. F. Rump & Sons; Harry S. Areher, Lebkuecher & Co., Merrill Bros., Mathews Co. and A. G. Schultz & Co.; John O. Slemmons, J. B. Bowden & Co.; Mr. Gruen, D. Gruen, Sons & Co.; Frank A. Rydstrom, E. Howard Watch Co.; J. Rothschild, Kaffeman, Rothschild & Co.; J. F. Gorman, Woodside Sterling Co.; C. M. McFlick, T. G. Rider Pen Co.

Among the traveling representatives who called on the trade in St. Louis, Mo., last week, were: C. H. Davidson, Kohn & Co.; H. B. Rogers, Rogers & Co.; F. R. Horton, Carter, Howe & Co.; H. R. Shirley, T. B. Clark & Co.; George L. Jann, C. F. Rump & Sons; O. Krause, Arthur W. Ware & Co.; A. T. Hatch, S. B. Champlin Co.; C. L. Krugler, Mandeville, Carrow & Crane; Frank L. Wood, Ludwig Nissen & Co.; F. F. Gibson, Gibson, Krugler Co.; George W. Beardsley, Allsopp & Allsopp; C. A. Holbrook, Sloan & Co.; Thomas E. Rogers, Riker Bros.; A. B. Randall, Coddling & Heilborn Co.; George Pilzer, Goodfriend Bros.; H. R. Blackman, Champenois & Co.; S. W. Abbey, E. Ira Richards & Co.; I. Price, Louis Strasburger's Son & Co.; A. J. Sherrard, Enos Richardson & Co.; Mr. Lucas, Frank W. Smith Co.; Charles B. Evans, John R. Keim; William M. Bennet, Hartford Sterling Co.; F. C. Winship, H. C. Fry Glass Co.; John I. Moffitt, Battin & Co.

Optical Notes.

M. Schwab's Son, optician, Savannah, Ga., has purchased the business of E. H. Armstrong, Jacksonville, Fla. The new owners have made extensive alterations and installed machinery for lens grinding in the Jacksonville store. The firm continues its Savannah store.

Its first examination was given Jan. 29, by the newly appointed State Board of Optometry of Nebraska, in the Y. M. C. A. building in Omaha. There were 25 candidates. The examinations comprised 60 questions, divided into three groups. It was announced that the questions would count each 10 points; the practical use of the trial case, method and rapidity, 200 points; neutralizing lenses, 100 points; the use of other testing apparatus, 100 points, making a total of 1,000 points. A standing of 75 per cent. was required to pass the examination. All the candidates passed in a creditable manner.

I. Prager, who has bought out the business of David Urbach, Keyport, N. J., is remodeling the store and replenishing the stock. He expects to make many improvements in the way of beautifying the establishment.

Buffalo, N. Y.

John Campbell, who for several years conducted a jewelry business in Cohoes, N. Y., died recently at his home in that city, after an extended illness.

Word was received from New York last week to the effect that J. W. Bosche, 42 years old, said to be of the firm of Bosche Bros., jewelers, of this city, had committed suicide in the Astor House, New York. The man in question is believed here to be a member of the firm of Bosche Bros., carriage manufacturers, and not a jeweler.

A petition in bankruptcy has been filed in the office of the clerk of the United States District Court here by Jacob B. Greenburg, of this city. His debts amount to \$2,797, nearly all of which were contracted while he was in the jewelry business in Erie, Pa., in 1905. Exemption is claimed for his assets, amounting to about \$100. Mr. Greenburg has been employed of late in Buffalo as a clothing cutter.

The spirit of progress pervades the establishment of White, Wile & Warner, ring makers. There are no indications of temporary financial depression around their factory, but to the contrary, the very air is full of enthusiasm for the future. They have just added another floor to their building, which gives them the much needed extra room, in order to meet the requirements of their fast growing business. All the representatives of this house are now in their respective territories. Mr. Wile and Mr. Warner, members of the firm, also do considerable traveling. Mr. Wile is in the south and Mr. Warner on the Pacific Coast.

New Orleans, La.

Two well-dressed men recently entered the store of Coleman E. Adler, 810 Canal St., and asked to see some gold-handled penknives. The clerk, who was waiting on them noticed one of the men slip a knife up his sleeve and immediately charged him with the theft. The stranger offered to have his companion go for an officer and to search him, but when the companion went away he never returned. However, Mr. Adler sent for an officer and the man was taken to the Central Station, where the knife was found on him.

A largely attended meeting of the Louisiana State Optical Society in which the principal opticians of the State participated was held here last week, W. E. Houston, of the national association, presiding. The State association was recognized and affiliated with the American Association of Opticians, after which the delegates enjoyed a banquet at the Astrouma and a theater party in the evening. The officers elected are: President, S. P. Schuessler, Baton Rouge; vice-president, M. L. Krammer, Lake Charles; second vice-president, Ike Schwartz, Shreveport; secretary, Maurice F. Fitzgerald, New Orleans; treasurer, Nicholas Belliamore, New Orleans. Executive Committee: Harry Swartz, New Orleans; Jake Lowe, Monroe; E. J. Bohne, New Orleans, and Charles Claremont, Alexandria. Board of Examiners: Geo. A. Beavers, chairman, New Orleans; Harry Watson, New Orleans, and Harry Hollins, Jennings.

News Gleanings.

H. De Bill & Co., 181 Green St., Melrose Highlands, Mass., have discontinued business.

Charles A. Phelps has been chosen by the creditors as a trustee in bankruptcy of George C. Smith, Watertown, N. Y.

W. P. McFarland, Orange, Tex., has been appointed watch inspector for the Houston division of the Southern Pacific Railroad.

Theodore M. Fisher, the trustee in bankruptcy of Chas. F. Budd, Auburn, N. Y., will sell the bankrupt's stock at 82 Genesee St., Feb. 24, at 10 A. M. Application to confirm the sale will follow.

The Porter & Wiser Jewelry Co., Kansas City, Mo., announces that its new catalogue will be ready for distribution in about six weeks. The catalogue will give prices on both special manufacturing and repair jobs.

In a note published in a previous issue of THE CIRCULAR-WEEKLY, referring to the M. J. Wax Co., Portland, Ore., the name of the concern was erroneously spelled Max. This firm is located at 419-420 Worcester building, at 3d and Oak Sts., and acts as manufacturers' representatives for the Pacific northwest.

In the matter of the bankruptcy of Greenbrier Jewelry Co., W. R. Sutton and G. L. Eakle, Marlenton, W. Va., Referee-in-Bankruptcy Mathews has called a third meeting of creditors, which will be held in the Citizens' National Bank building, Charleston, W. Va., Feb. 22, at 10 A. M., at which time a dividend will be declared and paid.

Charles Smead Kenfield, who died in a private hospital in Northampton, Mass., Feb. 4, was at one time a well known jeweler at Amherst, and was the father of C. R. Kenfield, of that city. For 30 years he was in business in Washington and for 15 years was a locksmith of the Treasury Department. The deceased is survived by a son, two sisters and a brother.

Samuel Harrison Eaton, a prominent jeweler, of New Bern, N. C., and son of the late S. K. Eaton, was married last Wednesday to Miss Mary Emma Street, at the home of the bride in George St., New Bern. Immediately after the ceremony Mr. and Mrs. Eaton left on a wedding tour for the north, where they will visit New York, Boston, Providence and other cities and will return to New Bern about March 1.

Joseph H. Mills, who for the past 25 years has been superintendent of the M. W. Carr Jewelry Co., at Somerville, Mass., has severed his relations with that firm and left for Chicago, where he will engage in the manufacture of jewelry. At a reception tendered him before his departure he was the recipient of a traveling bag and umbrella from his personal acquaintances and a gold watch from his former employers and employes.

Word was received at Washington, Pa., last week, of the fact that C. F. Fischer, a young man who had just started in the jewelry business at Johnson, had been run down by an engine of the P. & L. E. Railroad, near Fayette City. His legs were crushed close to the body and he expired before aid could reach him. Mr. Fischer, who was about 20 years old, had just opened his jewelry store and was distributing hand

bills to the houses along the railroad advertising his business. The body was taken to the home of his parents in Smithton, where the funeral was held Thursday afternoon.

Owing to an inadvertency, the attractive catalogue issued by the Allan Jewelry Co., 285 King St., Charleston, S. C., was described Feb. 5, with a group of catalogues distributed by retail jewelers to the consumer. This catalogue was designed expressly for the use of retail jewelers. The description should have been printed under the head of wholesale jewelers' catalogues rather than incorporated in the group issued by retail jewelers.

The Varney Jewelry Co., Wichita, Kans., was recently incorporated at Topeka, with a capital stock of \$74,000, fully paid in. The officers are: President, I. F. Varney; vice-president, H. A. Reinhard; secretary and treasurer, Grace Varney. The directors are: Bertha M. Reinhard, Kass Harris and Herman Feuss. The new concern owns its own building and will occupy both floors. The lower floor will be devoted to jewelry, while the optical department and manufacturing and repairing departments will occupy the upper floor. The plant will be equipped with every modern storekeeping device and manufacturing equipment.

A combination tool patented by Wm. D. Smith, Denver, Colo., possesses certain features which are unique in many respects. The tool is intended to be utilized for a variety of purposes, including the staking of the roller table and the hairspring on the balance; for the holding and heating of the table roller and for setting the jewels; also for setting one or both pallet jewels. It is serviceable for the holding of watch hands, either hour, minute or second hand, when filing or broaching is to be done, and for annealing or for drawing the temper of small parts of watches such as pinions or balance staffs prior to drilling them for repivoting. Besides the above, Mr. Smith, who is reputed to have started the first jewelry factory in Denver, and is the inventor of numerous devices of interest to horologists and others.

The jewelry store of Allen A. Barrett, 777 Main St., Brockton, Mass., was entered Feb. 11 by a thief who got in through a back window. Stock to the value of \$125 was carried away. Show cases were emptied of their contents and drawers were scattered all about the floor. Valuable stock not in the safe for the night was overlooked. The burglary was reported to the police, who were given the following complete list of articles stolen: Silver spoon holder, dozen silver table knives, dozen silver dessert spoons, dozen silver tablespoons, dozen silver teaspoons, silver plated meat fork, silver plated gravy boat, three silver mugs, dozen fiddle pattern silver forks, half dozen vest chains, dozen scarf pins, five gold brooches in leather boxes marked A. A. Barrett, Brockton, Mass., half dozen ladies' gold plated neck chains, one pin, cameo ring, turquoise ring, gold ring with diamond, band ring, five lace pins in the store for repairs, three stickpins, gold ring, gold ring with opal, five neck chains, man's ring with ruby, corner chipped and marked S. M. U. R. P., gilt clock, Dresden china clock, shaving set.

Brazilian Black Diamonds.

THE scarcity of black diamonds and their demand for rock drilling has greatly enhanced their value in the past few years, hence the following report from Deputy-Consul-General Joseph J. Slechta, of Rio de Janeiro, on new fields of supply in Brazil will be of interest:

"From a comparatively small area in the central portion of the State of Bahia are taken almost if not all of the world's entire supply of the black diamond of commerce, used for the purpose of what is known as the diamond drill. This area lies along the upper waters of the River Verde, a tributary of the great river San Francisco, mostly in a range of mountains known as the 'Chapada Diamantina.' The American geologist, J. C. Branner, in surveying the greater part of the northern half of the State of Bahia, included this diamond district in his surveys and in connection therewith made a most important discovery. It had not been supposed that the diamond district extended at all to the west and north of the River Verde, but Dr. Branner's explorations reveal the fact that the same diamond bearing strata extend almost as far as the river San Francisco, covering an area of from 3,000 to 5,000 square miles.

"The diamonds are found in gravel and conglomerate formations. As little is known locally of the occurrence of these formations the property is not held at a high figure and success should attend the efforts of any one properly equipped with capital and mining experience entering upon the exploitation of these fields. The area in question may be approached by rail from either Bahia or Pernambuco. From the terminus of the railways a journey of many days, either by water or by mule back, would be necessary to reach the objective point."

Employment in the Watchmaking Industry in Switzerland.

RECENT statistics quoted by Consul Francis B. Keene, of Geneva, show that, out of a total population of about 3,500,000 inhabitants, the total of persons employed in the watchmaking industry in Switzerland is 115,617, of which 55,988 are male and 59,629 female. The total of watchmakers is 52,752, of which 35,378 are men and 17,374 women.

The distribution of the total 115,617 workers in the various cantons by percentage is as follows: Berne, 42.4; Neuchatel, 34.2; Solothurn, 7.5; Vaud, 6; Geneva, 4.2; Baselland, 1.2; Ticino, 0.7; and Schaffhausen, 0.1.

The correct address of Walter Powell Sons is 103 Baltimore St., Cumberland, Md., and not Baltimore, Md., as erroneously printed last week. The Walter Powell business in Baltimore has no connection with the above-mentioned concern.

George Frodsham, who was for many years a watchmaker, died at the home of his niece, Mrs. Wilkinson, at Hornell, N. Y., Feb. 11, after a long illness. The deceased was born in England, but had followed his trade in Hornell for many years and was well known there.

INDEX TO ADVERTISEMENTS.

Bel Bros. & Co.	27	Gugenheim, M.	35	Pfeiffer, W. S.	786
Blamis, T. W., Co.	11	Hagstoz, T. B., Ltd.	108	Potter & Balfinton Co.	32
Blossop Bros.	26	Hammel, Riglander & Co.	110	Price, Cyrus, & Co.	46
Bovin Mfg. Co.	Inside front cover	Harris & Harrington.	94	Prior, Charles M.	33
Bremer Gem & Pearl Co.	61	Hedges, A. J., & Co.	26	Providence Stock Co.	32
Canadian Platinum Works.	100	Hedges, Wm. S., & Co.	58	Racine, Jules, & Co.	92
Canadian Watch Case Co.	84	Heller, L., & Son.	48	Ranlett & Lowell Co.	94
Canderson, P. E., & Co.	102	Herpers Bros.	100	Reichhelm, E. P., & Co.	100
Carroll Crown Mfg. Co.	28	Hight Mfg. Co.	102	Reichman, A.	61
Carlwald Klement Co.	26	Hill & Schmidt.	23	Reinziehausen, W. F., & Co.	108
Carlson Turquoise Mines Co.	24	Himalaya Mining Co.	60	Revell, A. H., & Co.	106
Carsteln Bros. & Co.	42	Hirsh & Hyman.	48	Rice's, Bernard, Sons.	106
Carstine Bros. Co.	74	Hodenpyl & Walker.	54	Richards, J. M.	56
Casson & Spiegel.	27	Hoffman Novelty Co.	35	Richardson, Enos, & Co.	22
Cassida, John, & Son.	60	Hooper, H. J.	36	Robbins, Chas. M., Co.	33
Cassidy, Perline & Co.	56	Hopkins, E.	111	Rockford Watch Co.	92
Cassidy, Geo. M.	102	Hotel St. James.	106	Roger Williams Silver Co.	26
Cassett Jewelry Co.	34	Hraba, Louis W.	28	Rohrbeck, John E.	78
Cassidy & Bacon.	16	Hyde & Co.	84	Roseman, A.	60
Cassidy, J. & H.	32	Hillnols Watch Co.	72	Roy Watch Case Co.	78
Cassidy, S. O., & Co.	6	International Gem Co.	60	Rudolph & Snedeker.	94
Cassidy, Chester, & Son.	51	Irons, Joseph	28	Rumpp, C. F., & Sons.	104
Cassidy, Grlscom & Osborn.	25	Irving Cut Glass Co.	104	Saunders, Meuger & Co.	58
Cassidy, R. W.	106	Jacot Mule Box Co.	23	Schickerling Mfg. Co.	786
Cassidy, R., & Co.	12	Janitschek Co.	100	Schultz & Co., Inc.	29
Cassidy, Wm., Co.	102	Jeanne, F. A.	56	Sessions Clock Co.	94
Cassidy, S., Co.	101	Jorgeson, F. C., & Co.	102	Simmons, R. F., Co.	20
Cassidy & Vitell.	61	Jurgensen, Jules	94	Smith, Alfred H., & Co.	48
Cassidy, J. B., & Co.	27	Kahn, L. & M., & Co.	42	Smith, C. Sydney, Co.	16
Cassidy Polytechnic Institute.	92	Keck, Herman, Mfg. Co.	44	Smith, Frank W., Co.	18
Cassidy, D. F., Co.	76	Keller Jewelry Mfg. Co.	24	Smith, Wm., & Co.	34
Cassidy Mfg. Co.	6	Kent & Woodland.	24	Snow & Westcott.	28
Cassidy, Howe & Co.	23	Ketcham & McDougall.	29	Sohn & Hyman.	60
Cassidy National Bank.	68	Keystone Watch Case Co.	90	Solderine Co.	100
Cassidy Art Metal Works.	24	Kinney Co.	31	Solidarity Watch Case Co.	18
Cassidy Frères	29	Kirby, H. A.	64	Spencer, E. L., Co.	33
Cassidy Gold & Silver Refining Co.	31	Kohlbusch, Herman, Sr.	78	Star Watch Case Co.	8
Cassidy, J. J.	50	Kohn, Alois, & Co.	27	State Bank	66
Cassidy & Straight.	108	Kremetz & Co.	20	Steiner, Louis	28
Cassidy S., Co.	23	Krower, Leonard	70	Stern Bros. & Co.	50, inside back cover
Cassidy & Court.	31	Langendorf Watch Co.	94	Stern & Corn.	33
Cassidy, M.	30	Lapp & Flersem	76	Sternau, S., & Co.	14
Cassidy & Beguelin.	64	Larter & Sons	40	St. Louis Watchmaking School.	92
Cassidy Co.	50	Lederer, S. & B., Co.	34	Street, Geo. O., & Sons.	23
Cassidy & Fitzgerald.	104	Lees & Sanders.	108	Sussfeld, Lorsch & Co.	34, 104
Cassidy, C.	102	Leiman Bros.	100	Swartzchild & Co.	78
Cassidy, Clark & Co.	25	Lelong, L., & Bro.	109	Tavannes Watch Co.	84
Cassidy, Louis J.	24	Lewy & Cohen	29	Title Guarantee & Trust Co.	66
Cassidy's, James H., Sons.	109	Lisner, D., & Co.	19	Tront, Charles L., & Co.	29
Cassidy Show Case Co.	106	Lissaner & Co.	56	Untermeyer-Robbins Co.	70
Cassidy, Bagnall & Co.	31	Lorsch, Albert, & Co.	42	Urich, S.	35
Cassidy, C., & Sons.	104	Lowe, Edwin, & Co., Inc.	32	U. S. Smelting & Refining Works.	109
Cassidy, O. M., Estate.	15	Lyons Mfg. Co.	17	Van Dam, Eduard.	44
Cassidy Watch Case Co.	92	Maintien Bros. & Elliot.	35	Van Dusen & Stokes Co.	32
Cassidy-Hampden Watch Mfg. Co.	10	Market & Fulton National Bank.	66	Van Schoor, C.	35
Cassidy, T. J., Co.	30	Marson, A.	102	Wachter Mfg. Co.	84
Cassidy, H., & Bro.	22	Mercantile National Bank.	67	Wadsworth Watch Case Co.	9
Cassidy & Co.	60	Meyerowitz Bros.	44	Wagenführ, Charles	50
Cassidy Bros.	54	Miller, Fuller & Whiting Co.	35	Wagner Comb Mfg. Co.	28
Cassidy National Watch Co.	88	Mount & Woodhull.	56	Waite-Thresher Co.	26
Cassidy, P. H. Chain Catch.	32	Myers, S. F., Co.	30	Wakefield & Sellar Co.	78
Cassidy, Joseph, & Co.	3	Nassau Bank	66	Waltham Watch Co.	86
Cassidyheimer, Louis	60	New England Watch Co.	95	Washburn, C. Irving.	30
Cassidy Co.	109	New York Jewelry Purchasing Co.	82	Wells, Chester H.	31
Cassidy, Theodore W., & Bro. Co.	36	New York Standard Watch Co.	93	Wendell & Co.	7
Cassidy, Henry, & Bro.	19	Nissen, Ludwig, & Co.	25	Wheeler, Hayden W., & Co.	50
Cassidylander, R., L. & M.	50	Noel, Rudolph, & Co.	48	Whiting & Davis.	14
Cassidy, J. H. & F. H.	29	Oneida Community, Ltd.	Outside back cover	Whiting Mfg. Co.	13
Cassidy & Griser.	23	Oppenheimer Bros. & Veith.	44	Wightman & Hough Co.	30
Cassidy Sales Co.	36	Oskamp-Nolting & Co.	30	Wodiska, Julius	30
Cassidyfriend Bros.	58	Osmers-Dougherty Co.	24	Wolcott Mfg. Co.	706
Cassidy Co.	62	Osmun-Parker Mfg. Co.	22	Wollstein, L. & M.	109
Cassidy, Herman	94	Ostby & Barton Co.	17	Wood, Chas. F., & Co.	54
Cassidy, August	102	Owanda Cut Glass Co.	104	Wood, J. R., & Sons.	4, 5
Cassidy's Excelsior Sign Co.	31	Parazien, A. D.	94	Zarembowitz, A.	100
		Penfold, Wm. C., Co.	95	Zimmern, Henry, & Co.	109

Special Notices.

Payable invariably in advance.

Rates 75c. per insertion for notices not exceeding 5 words; additional words, 2c. each.

SITUATIONS WANTED, 1c. a word each insertion; minimum charge, 25c.

Heavy type, 5c. a word; minimum charge, \$1.25. Display cards, \$2.00 per inch.

In all cases, if answers are to be forwarded, 10c. extra to cover postage must be enclosed.

All answers to advertisements addressed care The Jewelers' Circular-Weekly, should be sent to the New York Office, unless the Chicago Office is specifically mentioned.

Situations Wanted.

JEWELER, experienced on all kinds of repairing, wishes position. Address Alex Kraus, 227 E. 83d St., New York.

CHASER, on casting and hollow ware, with first class references, desires position. Wimes, 548 E. 82d St., New York.

GERMAN, first class silver and false core work moulder, desires position. John Tepley, 1006 E. 151st St., Bronx, N. Y.

WATCHMAKER and optician wishes position; can furnish best references. Address "L., 3370," care Jewelers' Circular-Weekly.

FIRST CLASS watchmaker and engraver wants position. Address "Watchmaker and Engraver," 131 S. Prince St., Lancaster, Pa.

SILVERSMITH, on silver hollow ware, desires position; first class references. Goldberger, care Wimes, 548 E. 82d St., New York.

WATCHMAKER, engraver and salesman; young man, single, no bad habits; A1 references. Address C. W. Helm, Franklin, Tenn.

WATCHMAKER, thoroughly practical, with 20 years' experience; first class references. Address "P., 3331," care Jewelers' Circular-Weekly.

ENGRAVER, married, desires steady position; can do clock work and some jewelry repairing. Address "E. W.," 114 S. 7th St., Vincennes, Ind.

WANTED, steady position with good house by experienced clockmaker; has good reference. "N. T., 3402," care Jewelers' Circular-Weekly.

WATCHMAKER wants position; experienced on Swiss and American watches, with complete set of tools. Ed. Herzberg, 402 E. 79th St., New York.

WATCHMAKER, who is first class, wishes a good, steady position with a good, reliable firm. Address "H. J., 3418," care Jewelers' Circular-Weekly.

WATCHMAKER and engraver, experienced in all grades of watches; state particulars and salary. Address "Watchmaker," 103 Broadway, Princeton, Ind.

POSITION WANTED by first class jobbing jeweler, stone setter and colorer; 20 years' experience. Address M. J. Nolan, 357 E. 134th St., New York.

YOUNG MAN, 25, desires position with wholesale house; eight years' experience in office and factory. C. G. Braxmar, Jr., 352 W. 23d St., New York.

A DESIGNER and modeler would like a position as designer of jewelry or silver deposit ware. Address "C., 3339," care Jewelers' Circular-Weekly.

YOUNG MAN wishes position as salesman, order or stock clerk in wholesale, retail jewelry or silver house. Address "X., 3072," care Jewelers' Circular-Weekly.

PLATER, colorer and etcher, experienced on jewelry, silver and metal novelties, desires steady position. Address "H., 3208," care Jewelers' Circular-Weekly.

JEWELER, young man, eight years' experience, wishes position as jeweler or learn watchmaking and engraving. Address "Carlson," 240 E. 25th St., New York.

STRICTLY first class watchmaker, with first class tools and references, wishes position; New York City preferred. "H. R., 3382," care Jewelers' Circular-Weekly.

DIAMOND SETTER and jewelry repairer, age 23, desires a position with a reliable house; has 10 years' experience. "G., 3341," care Jewelers' Circular-Weekly.

ENGRAVER, young man, 25 years of age; samples will show character of work; salary, \$25 per week; best reference. J. George Brooks, 115 E. 28th St., New York.

WATCHMAKER desires to quit the bench, wishes a position with a material house or some other occupation. Address "A. V., 3417," care Jewelers' Circular-Weekly.

WATCHMAKER and jeweler, first class, eight years' experience, desires a permanent position; good references. Address "M., 3396," care Jewelers' Circular-Weekly.

A YOUNG MAN, 21 years, thoroughly familiar with the jewelry business, desires a position with a wholesale house. "Competent, 3337," care Jewelers' Circular-Weekly.

YOUNG MAN, with knowledge of repairing clocks and jewelry, wants to finish trade under first class watchmaker; gilt-edge reference. H. P. Thompson, Oil City, Pa.

ENGRAVER wishes position; can do jewelry repairing and some clock work; will give reference and sample plate. Address "M. R., 3416," care Jewelers' Circular-Weekly.

WANTED, by March 1, gold jewelry, rings or general line for middle west, by party having large trade; best of references. "T., 3381," care Jewelers' Circular-Weekly.

EXPERIENCED stock and order clerk, with four years' experience, wants to connect with a jewelry house, at once; references. "V., 3410," care Jewelers' Circular-Weekly.

DIAMOND SETTER, jeweler, first class, experienced on high grade platinum work, desires position; best references. Address "R., 3379," care Jewelers' Circular-Weekly.

A1 MANUFACTURING expert on platinum, order work and repairing, also stone setter, wishes position; best reference. Address "P. F., 3361," care Jewelers' Circular-Weekly.

FIRST CLASS diamond and all around setter, with knowledge of making jewelry, also good carver, wishes position out west. "H. B.," 96 Linwood St., Brooklyn, N. Y.

FIRST CLASS watchmaker, with tools, desires position at once; middle age man; competent to handle railroad work. Address "E. H. B.," 45 Charles St., Springfield, Mass.

SILVER SALESMAN, 10 years' experience, desires to connect with first class retail house; can furnish best of references. Address "J., 3302," care Jewelers' Circular-Weekly.

FIRST CLASS jeweler and clock repairer, can help on watches, wants position in northern part New York State; A1 reference. "W., 3391," care Jewelers' Circular-Weekly.

SITUATION WANTED by young man, 25 years old, eight years' experience in retail store; write for particulars and references. Address Clarence J. Bell, Cooks Point, Davenport, Ia.

WATCHMAKER, four years' experience, can do optical work and some jewelry repairing; own tools; A1 references. Address "Watchmaker," 932 S. 3d St., W., Cedar Rapids, Ia.

JEWELER, first class hollow chain bracelet maker, desires position; experienced on all kinds of chains; willing to leave New York City. Oberlander, 157 E. 112th St., New York.

FIRST CLASS diamond setter, all around, wants position with reliable firm; best reference; no objection to going out of town. Address "O., 3388," care Jewelers' Circular-Weekly.

WANTED, position as engraver in reliable jewelry house by first class man; long experience; at liberty owing to breach of contract. Address "E., 3347," care Jewelers' Circular-Weekly.

EXPERIENCED WATCHMAKER and engraver would like steady position in first class store; desires a change; east preferred. Address "C., 3268," care Jewelers' Circular-Weekly.

YOUNG LADY desires position with jewelry house; have experience with stock and general office work, also stenographer and typewriter. "K., 3279," care Jewelers' Circular-Weekly.

YOUNG MAN, 21, having almost five years' experience with diamond importing house, desires to make a change; can furnish best of references. "R., 2906," care Jewelers' Circular-Weekly.

A HIGH GRADE letter and monogram engraver desires permanent position with a reliable firm after March 1; best of references. Address "Jeweler, 3415," care Jewelers' Circular-Weekly.

WANTED, a position as engraver and to wait on trade, is desired by young lady of experience. will send sample of work and good references. E. M. Komray, 104 W. Tod Ave., Warren, O.

SALESMAN, young man, 21, thoroughly experienced in the retail jewelry business, is open for position, retail or wholesale; references. Address "M., 3554," care Jewelers' Circular-Weekly.

YOUNG MAN, anxious to learn watch and clock repairing; three years' experience; willing to work; best of habits and reference; own tools. H. H. Gabelmann, 107 Wallins St., Winsted, Conn.

WATCHMAKER, with optical diploma, open for engagement at high class work; trained in London; 20 years' American experience; highest references. "H. G., 3352," care Jewelers' Circular-Weekly.

YOUNG MAN, 24, thoroughly experienced in the jewelry business, desires position in same line, where advancement keeps pace with ability; A1 references. F. Winter, 312 Stockton St., Brooklyn, N. Y.

YOUNG MAN, 27, desires position as salesman, traveling or inside; eight years' experience in flat and hollow ware; highest references. Wm. Tollner, care D. C. Van Riper, 170 Broadway, New York.

ENGRAVER, young man, desires position with first class engraver, or an opportunity to learn watch work; good script letterer; samples on request; A1 reference. "D., 3355," care Jewelers' Circular-Weekly.

SALESMAN, young man, having nine years' experience with wholesale and retail house, wishes position as salesman or any kind of work; good references. Address "A., 3366," care Jewelers' Circular-Weekly.

BY TRAVELING salesman, with 10 years' acquaintance with the best jewelry trade in New York, Pennsylvania, Ohio and Kentucky; best references. Address "M. Y. G., 3420," care Jewelers' Circular-Weekly.

POSITION WANTED by a young man, a practical watchmaker, jeweler and salesman, with a good firm in New York or Brooklyn; position as watch salesman preferred. "M., 3389," care Jewelers' Circular-Weekly.

YOUNG MAN, 25 years, thoroughly familiar with the jewelry trade, speaking German, English and French, desires position with a wholesale or retail firm; good references. Address "Y., 3397," care Jewelers' Circular-Weekly.

EXPERIENCED young lady wishes position with diamond mounting house, weighing gold and platinum and taking full charge; is also office assistant and typist. "Recommended, 3373," care Jewelers' Circular-Weekly.

YOUNG MAN, age 22, with some experience on letter and monogram engraving, also with some experience in selling goods in a retail jewelry store, wishes position. Address "F., 3406," care Jewelers' Circular-Weekly.

SALESMAN, calling on New York City and out-of-town trade, desires change with A1 jobbing or manufacturing house; seven years' experience; highest references. Address "R., 3021," care Jewelers' Circular-Weekly.

WANTED, manufacturer's line of filled jewelry, silver or plated toilet or flat ware on commission, established trade in New York, Philadelphia, Baltimore and middle west. Eric R. Sheppard, 53 Maiden Lane, New York.

SITUATION WANTED by first class watchmaker and jeweler; have complete set of tools and can give references from present employer; will work for moderate salary. Address Harry Stone, 2308 Sixth Ave., Birmingham, Ala.

SITUATIONS WANTED.—Continued

MANUFACTURER'S LINE of 10 karat or 14 karat jewelry for New York, Philadelphia, Baltimore, Washington and the middle west; established trade; salary or commission. Address "V., 335," care Jewelers' Circular-Weekly.

DESIGNER on fine diamond and gold jewelry, with 11 testimonials, wishes position in either factory or as salesman in a fine jewelry store; personal references given. Address "Designer, 424," care Jewelers' Circular Weekly.

MAN, 27, understanding German and all details, silverware and novelties, for factory or sales-room detail work; highest references; 10 years' experience with prominent manufacturers. Address "X., 3395," care Jewelers' Circular-Weekly.

GOOD, experienced manufacturing jeweler, who understands fine and cheap work, has all models and designs necessary to be used, is looking for position as a foreman and to take charge of factory. Address "T., 3408," care Jewelers' Circular-Weekly.

JEWELRY and watch salesman, at present employed in New York City, desires change; 15 years' experience; also a thorough refractionist, understanding the optical business from the shop. Address "Optician, 3364," care Jewelers' Circular-Weekly.

WATCHMAKER, 20 years' experience; fine watches, French clocks, jewelry, optical goods; plain engraver and good salesman; steady and reliable; capable of taking charge of store; salary, \$23 to \$25. Address "Allen, 3405," care Jewelers' Circular-Weekly.

YOUNG WOMAN, stenographer, typewriter, has knowledge of bookkeeping, accurate and reliable, can adapt herself to any business, wishes permanent position at a moderate salary; Maiden Lane references. Address "Remington, 3357," care Jewelers' Circular-Weekly.

RST CLASS watchmaker, 30 years' experience, wants position; thoroughly competent on complicated work, railroad watches and adjusting, can take care of repairing department; New York or nearest vicinity preferred. Address "S., 3380," care Jewelers' Circular-Weekly.

RST CLASS REFRACTIONIST, 20 years' experience, A1 adjuster and fitter, good salesman, good address, at present employed as manager, desires change; very best references; want only a first class position. Address "Competent, 3284," care Jewelers' Circular-Weekly.

RST CLASS watchmaker wants permanent position; has had 25 years' experience; had charge of watch rack, received and estimated on work; has worked for the trade; American, 43 years old, married, sober, steady habits; can furnish best of reference; only reliable house need apply. "P., 3409," care Jewelers' Circular-Weekly.

RST CLASS watchmaker, fine letter and monogram engraver and graduate optician; 23 years' experience, five years' on railroad watches; several years in present position; do not repair clocks or jewelry; Indiana or Illinois preferred; would not go east of Indiana; town 8,000 to 25,000; first class references. Address "S. J., 3383," care Jewelers' Circular-Weekly.

ALL AROUND MAN, American, watchmaker, jeweler and engraver; first class workman, familiar with railroad inspection, some knowledge of optics; could take entire charge of store; good tools and reference. "G., 3407," care Jewelers' Circular-Weekly.

Help Wanted.

WANTED, an engraver, who could assist in clock and jewelry work. S. Joseph & Sons, Des Moines, Ia.

WANTED, optician and engraver; only experienced, well recommended man. Chas. S. Stiff, Little Rock, Ark.

WANTED, a young man to do clock and general repairing; wages, \$8 to \$10 per week. H. D. Fisher, Oswego, N. Y.

WANTED, an experienced workman, who can do good watch work and nice engraving; good salary. Address J. S. Baird, Watertown, N. Y.

A FIRST CLASS jeweler, one who can wait on customers, for New York. Write "B. O., 3403," care Jewelers' Circular-Weekly.

WANTED, first class watchmaker, fair engraver and jeweler; permanent position, good salary. Address "Stamford, 3419," care Jewelers' Circular Weekly.

WANTED, first class watchmaker, one who is experienced on railroad work, also engraver preferred; state reference, wages, etc., in first letter. "C. 3422," care Jewelers' Circular-Weekly.

FIRST CLASS watchmaker in Connecticut town of 10,000 population; permanent position; good salary; first class reference required. Address "V., 3384," care Jewelers' Circular-Weekly.

WANTED, first class watchmaker; a permanent position for one thoroughly experienced and competent to take charge of the department. J. Wiss & Sons, 683 Broad St., Newark, N. J.

WANTED, at once, first class watchmaker, jeweler and clock repairer; state reference, experience and salary in first letter; permanent position. Address Mrs. J. T. Douglas, Brewton, Ala.

WANTED, a man who can do good work in clock repairing; must be steady and come well recommended; also a good jeweler for repairing; steady work to a good man. B. U. Tapken, New Brunswick, N. J.

WANTED, experienced retail jewelry salesman, window trimmer and stock keeper; good salary and permanent position to right man; send references and state salary in first letter. J. Lowinsohn, Birmingham, Ala.

WATCHMAKER, jeweler and plain engraver; must have 10 years' experience; married man preferred; permanent position; send references and state salary in first letter. Address "H., 3411," care Jewelers' Circular-Weekly.

WANTED, salesman, acquainted with the wholesale jewelry and notion trade in the east to sell boxes and display goods for a manufacturing concern; state references and experience. Address "N., 3372," care Jewelers' Circular-Weekly.

WANTED, first class watchmaker, engraver and jewelry repairer, one capable to take full charge of bench; salary, \$25 per week and permanent position to right man; address with references and sample of engraving. J. Lowinsohn, Birmingham, Ala.

WANTED, by March 1, a first class engraver, designer and manufacturing jeweler for a fine store; permanent position for a good, competent man; state full particulars and salary expected in first letter; San Diego has the finest climate in California; population, 45,000. The Ernsting Co., 915 5th St., San Diego, Cal.

WATCHMAKER and jewelry repairer who can translate from French and German into English, and who knows something about the theory of horology, will be offered desirable position; state age, nationality, education, general qualifications, etc. "R. J., 2314," care Jewelers' Circular-Weekly.

Business Opportunities.

WHAT have you to exchange for \$3,000 stock and fixtures in storage? Reason, other business interests. Flegel Jewelry Co., Racine, Wis.

WANTED, the best paying jewelry business, in good town, that \$2,000 to \$3,000 will buy. "Jeweler," care H. S. Blanchard, Miller Bldg., Chicago Heights, Ill.

A RING FACTORY, doing fine work, and well equipped; a close price will be considered for cash offer; write if interested. Address "N., 3290," care Jewelers' Circular-Weekly.

FOR SALE, established manufacturing business of chains, bracelets and rings on Maiden Lane, New York; machinery sold on easy terms. Inquire M. Greenberg, 228 E. 7th St., New York.

WILL PURCHASE, for spot cash, jewelry, silverware, clocks, etc., also jewelry and silverware lined boxes new or second hand. Sterling Jewelry Co., 54 W. 34th St., New York.

\$3,500 BUYS stock and fixtures in town of 4,500 inhabitants in Iowa; watch inspectors; last year's business, \$5,400; only cash purchase accepted. "C., 3386," care Jewelers' Circular-Weekly.

FINE LOCATION, western Iowa, 1,000 inhabitants, owner 15 years at same stand, wants to retire; small cash payment with good references can buy. Inquire the A. F. Smith Co., Omaha, Nebr.

LARGE MANUFACTURER of jewelry and diamond mountings offers factory for sale; arrangements can be made for the seller to take the entire production. Address "Box 3413," care Jewelers' Circular-Weekly.

JEWELRY FACTORY for sale or to let; safe, tools, models, flasks and all machinery in good order, running by electricity or steam power; good light and ventilation; low rent; Fulton St., near Nassau St., New York. Address "Z., 3399," care Jewelers' Circular-Weekly.

IF YOU HAVE a surplus stock of diamonds, watches or jewelry, send them to me and I will send cash for same; all business strictly confidential. E. Noel, 552 46th Place, Chicago, Ill.

RARE OPPORTUNITY to buy good paying jewelry and optical business in western Pennsylvania town of 3,500 population, surrounded by steel works and coal mines; no opposition; reasons for selling, other business; \$1,400; only cash will buy it. Address "Steel Works, 3421," care Jewelers' Circular-Weekly.

FOR SALE, old established jewelry and watchmaker's store; also handle string musical instruments; store fixtures and large Mosler safe; only small capital required; good location; two years' lease; rent low; must be sold by March 15; good reasons for selling. Address H. Rose, 535 Market St., Chattanooga, Tenn.

AT 50 CENTS on the dollar and less, corals, jets, ambers, plated and gold filled jewelry, solid gold baby pins, chains, etc., also a lot of diamond jewelry bought at trade auction sales; sent on memo. bills to well rated jewelers; sold for cash only. Address Dan I. Murray, broker and leading auctioneer of America, 3 Maiden Lane, New York.

FOR SALE, a nice retail jewelry and souvenir business, located on Penn. Ave., Washington, D. C.; stock over \$10,000; will reduce if desired; sale at inventory price or less if purchased outright; owner unable to give the business his personal attention, being disabled. Address "S., 3326," care Jewelers' Circular-Weekly.

FOR SALE, a complete jewelry factory, formerly Eisler & Laubheim's shop, at 87 Maiden Lane; large and light; modern machinery, models, dies, safes and fixtures; includes lease; all at very reasonable price; splendid opportunity. "A. S.," Room 55, 65 Nassau St., New York.

LEADING jewelry business in one of the best towns on Puget Sound; population, 25,000; 1907 business, \$23,500; stock invoices, \$17,000; fixtures, \$2,000; railroad watch inspector; can reduce stock to \$10,000; terms one-half cash, balance bankable paper; repair work, \$225 a month; net profits in two years, \$8,000; unless you mean business don't write me; other business interests demand my attention reason for selling. "Puget Sound, 3320," care Jewelers' Circular-Weekly, 42 E. Madison St., Chicago, Ill.

DO YOU WISH TO RETIRE? Why not turn your entire store or surplus stock into cash? We pay the highest prices, also advance liberal cash amounts on stocks; communicate with us before consulting others; we act quick and strictly confidential. Brooklyn Purchasing Syndicate, 608 Broadway, Brooklyn, N. Y., Telephone, 2328 Williamsburg.

Wanted to Purchase.

WANTED, jeweler's power rolling mill; must be in first class condition and reasonable in price; give full particulars when writing. W. E. Mowrey, 408 Ryan Annex, St. Paul, Minn.

(Special Notices continued on page 82.)

If You Know the Marks

you are not confined to the limitations of your stock, but will be able to supply any goods desired. Frequently a resident of a town or city will return from a visit to a larger city, bringing back an attractive novelty or piece of jewelry that is greatly admired by her friends, who will probably want to obtain others like it. They will first call on a local jeweler and if he is not an up-to-date jeweler he will turn them away disappointed because he has not the articles in stock. If, however, he is a progressive dealer, he will examine the trade-mark on the article, identify the maker and send for a line on memorandum. He will tell his prospective customers that he has not the goods in stock just at present, but will have them in a few days. He will make a sale, and every sale counts. But more than this, he will agreeably surprise and please his patrons and will convince them that it is not necessary to go out-of-town to obtain the latest and best productions of the jeweler and silversmith.

“TRADE-MARKS OF THE JEWELRY AND KINDRED TRADES”

(Second Edition)

will enable the jeweler to identify the maker of any article embraced in the jewelry and kindred trades. It illustrates 4,000 marks and covers every branch of the trade. It also contains much interesting and valuable reading matter on the subject of trade-marks in general.

PRICE \$3.00,

Express Prepaid.

PUBLISHED BY

The Jewelers' Circular Pub. Co.
11 John Street, New York.

Special Notices.

(Continued from page 81.)

For Sale.

FOR SALE, jeweler's safe, inside dimensions, 24 x 27 x 30. Ford & Carpenter, 2 Maiden Lane, New York.

FOR SALE, reducing machine for dies, electric motor and appliances. Brenner, 624 Madison Ave., New York.

FOR SALE, one Marvin safe, one pair flat rollers and one pair wire rollers, cheap. R. Schaefer, 14-16 John St., New York.

FOR SALE, one complete set of fine watchmaker's tools, including Whitcomb lathe and attachments, bench wheel, etc.; list sent on application. Hengen-Bates Co., Baltimore, Md.

FOR SALE, platform scales, two dynamos for coloring room, three ft. press, gas furnace, electric furnace, rotary shears, four scratch brush heads, bench vise, air pumps. The Chas. M. Robbins Co., Attleboro, Mass.

ONE LARGE jeweler's safe, 72 inches long, 44 inches wide and 32 inches deep, outside measure; also optical goods, trays and double jeweler's bench; write for further information. Address "E. D., 3387," care Jewelers' Circular-Weekly.

To Let.

FIREPROOF LOFTS, reinforced concrete building, eight minutes from Maiden Lane, 150 feet from subway station, 41 x 95; elevator and heat. Address owner, Van Nostrand, 118 Chambers St., New York.

Miscellaneous.

WATCH REPAIRS wanted; good work, low prices. H. Rudolph, 49 Hoyt St., Brooklyn, N. Y.

MOST DIFFICULT and complicated repairing of clocks and watches of every description carefully executed for trade. Robt. Scholz, Room 49, 115 Nassau St., New York.

Recently Published

Gems and Precious Stones

Their Characteristics, Localities of Production
Tests and Some Current Literature

Cloth, Postpaid, \$1.00

Published by
THE JEWELERS' CIRCULAR PUB. CO.
11 John Street, New York

PATENT DEPARTMENT



IN WHICH IS CONTAINED A LIST OF THE LATEST PATENTS GRANTED BY THE UNITED STATES AND GREAT BRITAIN, THE UNITED STATES PATENTS THAT HAVE EXPIRED AND THE REGISTERED TRADE-MARKS.

UNITED STATES PATENTS.

ISSUED FEB. 11, 1908.

878,616. CUFF-BUTTON. GEORGE W. DOVER, Cranston, R. I. Filed Feb. 9, 1907. Serial No. 356,523.

In a button the combination with a solid bean, of



bar whose end is within the solid bean, and inclined rows of knurls upon the portion of the bar within the bean.

878,716. WATCH-BARREL. LEWIS A. FALLER, Nashville, Tenn., assignor of one-fourth to the B. H. Steif Jewelry Co., Nashville, Tenn. Filed April 1, 1907. Serial No. 365,749.

In a watch movement, top and bottom plates, a spring barrel seated and retained on the bottom plate and having an enlarged externally threaded tubular hub presenting an opening, a cover plate arranged over the upper end of the barrel and provided with an enlarged central opening in line with

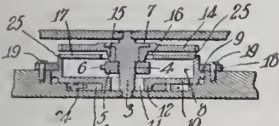

the opening in the hub, a toothed ratchet wheel threaded onto said hub, and an arbor extended through the openings in the hub and cover plate and terminally journaled in said upper and lower plates, said openings being of greater diameter than that of the arbor to permit relative movement of the latter and barrel for disposing of one of said parts eccentric with respect to the other.

878,739. KEY FOR WATCHMEN'S CLOCKS AND SECURING DEVICE THEREFOR. ABRAHAM A. NEWMAN, Chicago. Filed Sept. 19, 1906. Serial No. 335,247.

The combination with a key provided with a recess in its handle, of securing means therefor comprising a section of safety chain and an opened link threaded through that portion of the

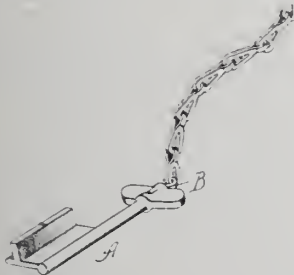

end link of the chain formed by the adjacent openings of the free end of said link and having its free ends inserted in the recess in the key and permanently secured therein.

878,740. KEY FOR WATCHMEN'S CLOCKS AND SECURING DEVICE THEREFOR. ABRAHAM A. NEWMAN, Chicago. Filed Sept. 19, 1906. Serial No. 335,248.

The combination with a key having an opening at its upper end, of a length of fox-tail chain having one end inserted in said opening and being perma-

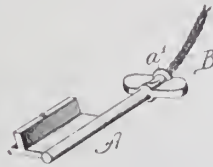

nently held in place by the metal of the key, whereby the removal of said key from the chain and its subsequent replacement without detection is prevented.

878,741. MARKING DEVICE FOR WATCHMEN'S CLOCKS. ABRAHAM A. NEWMAN, Chicago. Filed Dec. 4, 1906. Serial No. 346,276.

The combination with a cylinder having a plurality of series of characters, of a key having a character adapted to co-operate with one of the characters on the cylinder, a cam upon the key and means carried by the cylinder and adapted to

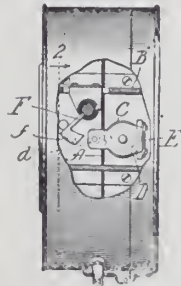

engage with the cam on the key as the key is turned whereby the cylinder is rotated to secure proper engagement between the key and cylinder.

878,742. MARKING DEVICE FOR WATCHMEN'S CLOCKS. ABRAHAM A. NEWMAN, Chicago. Filed Dec. 4, 1906. Serial No. 346,278.

The combination with a rotatable device, having different series of characters, of a key provided

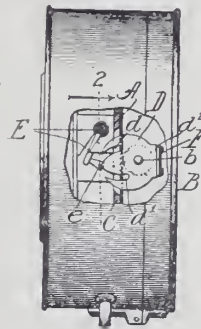

with an engagement device and adapted to be turned to rotate said rotatable device to bring the proper series of characters into operative position.

878,885. SCARF-PIN. ELMER G. KNOOP, Columbus, O. Filed June 5, 1907. Serial No. 377,412.

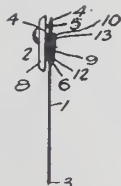

A pin of the type set forth, comprising a shank having pointed upper and lower ends, and formed

with spaces protuberances and a head slidably engaged on said shank between said protuberances.

878,800. WATCH-FOB. CHARLES L. HILLE, Boston, Mass. Filed June 16, 1906. Serial No. 322,115. Renewed Oct. 4, 1907. Serial No. 395,965.

A fob, comprising a strap having reduced portions, strap suspending means, said reduced portions being adapted to accommodate said strap suspending means and charm suspending means, a



clasp for securing the fob in its folded position, and means encircling one of said reduced portions for suspending the fob.

878,911. STYLOGRAPHIC PEN. JACOB ULLRICH, Hoboken, N. J. Filed Oct. 15, 1907. Serial No. 397,581.

A stylographic pen provided with an ink barrel, an inclosed air tube having an expanded lower bore to form an integral housing and a shoulder at the upper end of said housing, a nozzle communicating with the ink barrel, a perforated bushing in the

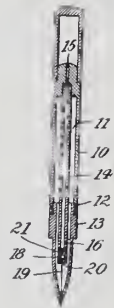

bottom of the housing, a needle passing through the bushing and having a head within the housing, and a spring within the housing that engages said shoulder and head, substantially as specified.

DESIGNS.

39,084. CHARM, PIN OR SIMILAR ARTICLE. SAUL ROBERT JACOBS, Alameda, Cal. Filed Jan.

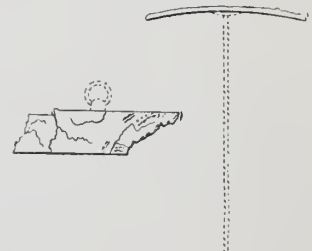

10, 1905. Serial No. 410,281. Term of patent 7 years.

(The same patentee has also obtained design patents for charms, pins, etc., embracing the maps of other States, which patents bear numbers 39,084 to 39,116, inclusive.)

39,118. GLASS BOWL. RICHARD MURR, Chicago.

Buy Watches With Our Patent Ball-Bearing Bow

Already on the Market

No watch case should be without it.

BEWARE OF IMITATION



Should your jobber not sell cases with these bows, write us and we will give you a list of jobbers who do.
 Patented July 25, 1905; May 21, 1907. Other patents applied for.
 Patented in foreign countries.

The Wachter Manufacturing Co.
HARTFORD, CONNECTICUT



American Watch Case Co.,

9-11-13 Maiden Lane

A.W.C.CO

New York

Practical Course in Adjusting

Published Price, \$2.50
 Special Reduced Price, \$1.50, Postpaid

All Jobbers, or
 Jewelers' Circular Publishing Co.

NEW ENGLAND WATCH REPAIRING FOR THE TRADE

GEO. W. HYDE & CO., 101 Tremont Street, Boston, Mass.

Make a Specialty of Repairing

NEW ENGLAND WATCHES

Work returned in one week, and guaranteed to be satisfactory in every respect
 Recommended by The New England Watch Co.

4

Cardinal Points
 of
**TAVANNES
 WATCHES**

1. Adjustment to heat and cold.
2. Special nickel-steel balance hair-spring, making the watch proof against all electrical influences.
3. Interchangeable material coming in finished form and ready to use.
4. A broad guarantee covering its time-keeping qualities under all conditions.

TAVANNES WATCH CO.

2 and 4 Maiden Lane, NEW YORK

131 Wabash Ave., CHICAGO, ILL.

Filed Dec. 16, 1907. Serial No. 406,786.

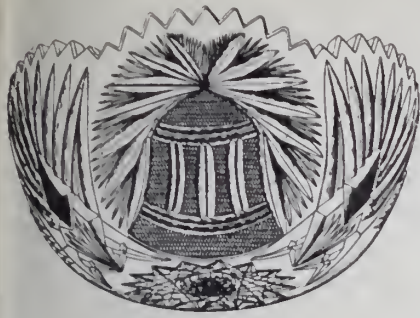

Term of patent 7 years.

39,119. TEA-KETTLE, STAND AND LAMP. SIGMUND STERNAU and CHARLES NELSON, New York and Brooklyn, N. Y., assignors to

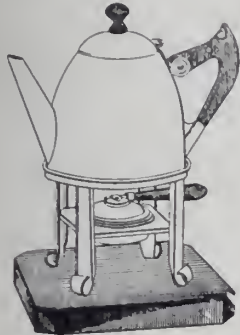

S. Sternau & Co., New York. Filed Dec. 3, 1907. Serial No. 404,966. Term of patent 7 years.

UNITED STATES PATENTS THAT HAVE EXPIRED.

[Reported especially for THE JEWELERS' CIRCULAR-WEEKLY by R. W. Bishop, Patent Attorney, Washington, D. C.]

Issued Feb. 3, 1891.

- 445,539. CORKSCREW. G. W. CAMPBELL and J. D. Hough, Lowville, N. Y.
- 445,553. SUSPENDERS. EMIL GUTMANN, New York.
- 445,600. FOUNTAIN-PEN. N. F. PALMER, Brooklyn, N. Y.
- 445,607. CLOCK STRIKING MECHANISM. A. M. LANE, Meriden, Conn.
- 445,622. PENHOLDER. LILLIAN L. W. McMURTRY, Mattawa, Canada.
- 445,652. COFFEE-POT. FREDERICK NORTON, New York, assignor of one-half to J. A. Britton, same place.
- 445,659. FORGING-BLANK FOR HOLLOW-HANDLE CUTLERY. W. H. CHAPIN Toledo, O.
- 445,683. NAIL-BRUSH AND POLISHER. HENRY WEBER, New Bedford, Mass.
- 445,707. UMBRELLA. ALFREDO WEIGANO, Sheboygan, Wis.
- 445,806. BUCKLE. C. H. FARMER, New York.
- 445,814. SEAMLESS PLATED WIRE. G. U. MEYER, Providence, R. I.
Design issued Jan. 30, 1894, for 14 years.
- 23,026. CLOCK-CASE. W. C. BROWN, Nantucket, Mass.
Designs issued Feb. 5, 1901, for 7 years.
- 34,021. NECKTIE-FASTENER. A. W. HILLBISH, Canton, O.
- 34,022. SKIRT-SUPPORTER. WILHELMINA M. LOWRIE, Buffalo, N. Y.
Design issued Aug. 2, 1904, for 3½ years.
- 37,078. SPOON. W. M. DAVIS, Washington, D. C.

Issued Feb. 10, 1891.

- 416,032. OPTOMETER. C. G. STEVENS, Watertown, N. Y.
- 416,069. CARD-CASE. A. A. Low, Brooklyn, N. Y.
- 416,079. GARMENT SUPPORTER. S. C. SCANTLEBURY, Eastport, Me.
- 416,226. TIME ALARM. W. E. GROVES, Boston, Mass.
Design issued Feb. 12, 1901, for 7 years.
- 31,055. SPOON HANDLE. W. A. JAMESON, Niagara Falls, N. Y.
Designs issued Aug. 9, 1904, for 3½ years.
- 37,076. CLOCK CASE. LOUIS MARQUART, JR., New York.
- 37,077, 37,078 and 37,079. CLOCK CASE. G. H. RHYNDANCE, New Haven, Conn., assignor to the New Haven Clock Co., same place.

BRITISH PATENTS.

(ABRIDGMENTS OF SPECIFICATIONS, 1906, FROM THE Illustrated Official Journal.)

ISSUE OF JAN. 29, 1908.

22,081. RECORDING AND TIMING GAMES. J. K. TUOMSON, Paisley, Scotland. Oct. 6.
Apparatus for recording and timing games of billiards, etc., comprises a continuously-working

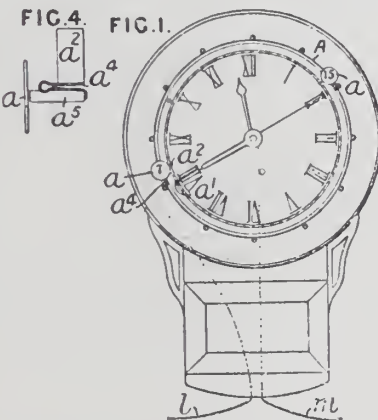
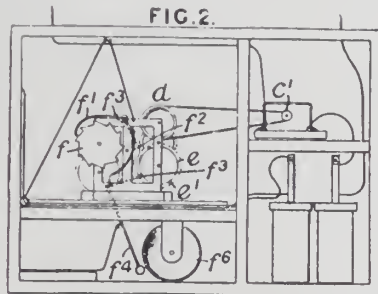

clock, Fig. 1, having secured to its face a brass ring A adapted to carry contact-disks a. The disks are numbered to correspond with the numbers of the tables, and are so placed on the dial that, by contact of the part a2, Fig. 4, with a bent part a1 of the minute-hand, they complete an electric circuit at the times at which the games on the respective tables should finish. The electric circuit is through wires l, m to a motor c, Fig. 2, which drives a wheel d forming part of a clock train comprising a disk e provided with pins e1. One of the pins e acts on the tail f2 of a lever f2, and moves its end f1 away from a bell f3, causing the arm f4 to complete a circuit to an electric bell; simultaneously, the lever f2 actuates a spring-controlled pawl f1, which rotates a ratchet-wheel f. The ratchet-wheel actuates a train of wheels, and so moves the finger of a recording-mechanism which records the number of games played. There are two recording-fingers which, in conjunction with two dials, record units up to 60, and sixties, respectively. The disks a are preferably revolvably mounted in sockets a5 on clips a4, Fig. 4. The electric currents may be derived from a battery or supplied power, and a switch may be inserted in the bell circuit. When the pawl f1 returns to its original position, the

lever f2 also returns, and a hammer on its arm f1 strikes a bell f3. The recording-mechanism is contained in a closed casing. The number of pins e1 may be varied, and the gearing of the mechanism may also be altered.

22,165. WATCH WRISTLETS. R. GEORGE, Walthamstow, and F. JARVIS, Clapton, London. Oct. 8.

A metal rim stamped out as shown in Fig. 3 is inserted in the dome of a leather watch wristlet

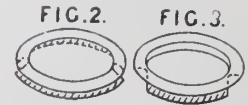

and pressed to the shape shown in Fig. 2. The rim is provided to keep the opening circular and to preserve the edges of the leather.

22,288. INDICATING TIME AT DIFFERENT PARTS OF THE EARTH. E. H. CULMER, London, N. Oct. 9.

Inside the 24-hour dial a is pivoted a rotary dial b, on which the names of various places of the

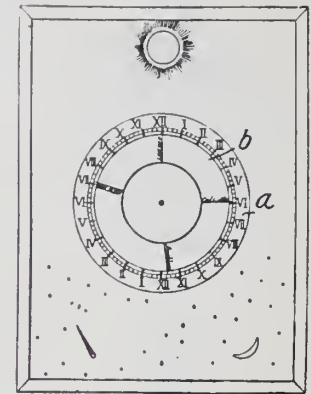

world are marked on radial lines against the hours corresponding to 12 o'clock at London. The dial may be suitably colored to represent the hours of the day and night, and decorated with the sun, moon, stars, etc.

22,321. WATCHES. J. F. KING, Sheridan, Montana, U. S. Oct. 9.

Pendants.—The casing 1 of the watch stem is hollow and receives the screwed bushing 4, which has an inner recess 5 for gutta-percha packing 6 frictionally engaging the winding-spindle 7. This

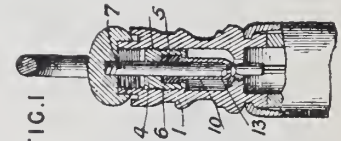

packing keeps foreign matter from entering the watch, and is kept in place by the spring-jawed hub 10, the ends of the spring jaws taking into a recess 13 in the spindle 7. The top of the bushing 4 has recesses to receive a spanner for the purpose of screwing the bushing into place.

Complete specifications accepted Jan. 15, 1908. 1907.

- 3,952. SUGAR-SPOON. COONER.
- 14,912. COMB. LANDESMANN.
Applications filed Jan. 6 to Jan. 11, 1908.
- 307. POCKET-BOX. M. K. BIRKHOZ, Hull.
Complete specification.
- 347. BRACELET. SAUL BETTS, Finsbury, London.
- 452. HAT-FASTENER. C. A. CURDLING and CARRIE HUGHES, Dartford. Complete specification.
- 475. CURLING-IRON. EWALD LOSEBRINK, London.
- 523. ESCAPEMENT FOR WATCHES AND CLOCKS. R. W. BUCKMAN, Oxfordshire.
- 659. MANUFACTURE OF SPOONS. HANS MURY, London. Complete specification.
- 666. HAT-FASTENER. G. N. HALL, Birmingham.
- 705. COMBINED BRACELET AND PURSE. WILLIBALD RAU, London. Complete specification.



WALTHAM JEWEL SERIES WATCHES



DIAMOND; NICKEL;

17 diamond and ruby jewels; both balance pivots running on diamonds; raised gold settings; steel escape wheel; exposed sapphire pallets; compensating balance, adjusted; meantime screws; patent Breguet hairspring, hardened and tempered in form; patent micrometric regulator; tempered steel safety barrel; gold train; exposed winding wheels.

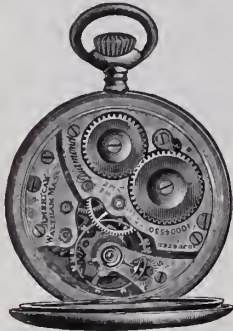

RIVERSIDE; NICKEL;

17 fine ruby jewels; raised gold settings; steel escape wheel; exposed sapphire pallets; compensating balance, adjusted; meantime screws; patent Breguet hairspring, hardened and tempered in form; tempered steel safety barrel; red gold center wheel; exposed winding wheels.

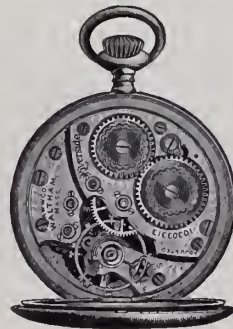

RUBY; NICKEL;

15 jewels; raised settings; exposed pallets; compensating balance; meantime screws; patent Breguet hairspring, hardened and tempered in form; tempered steel safety barrel; exposed winding wheels.

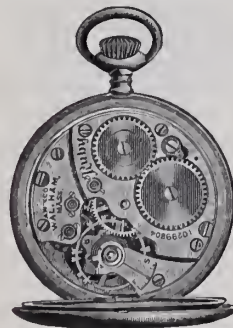

HUNTING OR OPEN FACE

These movements may be obtained in a great variety of Gold Cases, from Plain Polished to the most elaborately Engraved, Carved and Enameled.



Movements Manufactured and Guaranteed by
WALTHAM WATCH COMPANY
WALTHAM, MASS.



THE HOROLOGICAL REVIEW



A CATECHISM OF THE LEVER ESCAPEMENT

Being an Informative and Instructive Series of Questions and Answers for Watchmakers and Apprentices.

(Written expressly for THE JEWELERS' CIRCULAR-WEEKLY by T. J. WILKINSON.)

(Continued from issue of Feb. 5.)

QUESTION:—Name the escapement parts from which the lever receives its lifting energy.

ANSWER:—It is derived from the lift on the teeth of the escape wheel, and the lift on the impulse face of the pallet.

QUESTION:—To what parts and escapement actions is the motion of the lever from bank to bank due?

ANSWER:—To the lifts, on tooth and pallet jewel and the locks.

QUESTION:—Show by means of a drawing that part of a tooth and of a pallet

ANSWER:—It is also measured from the center of the escape wheel.

QUESTION:—What is meant by the expression "pallets' locking face"?

ANSWER:—That part of a pallet jewel with which the escape wheel tooth comes in contact when it drops. See Fig. 10, C to B.

QUESTION:—What does the term "pallets' impulse face" imply?

ANSWER:—It has reference to that part

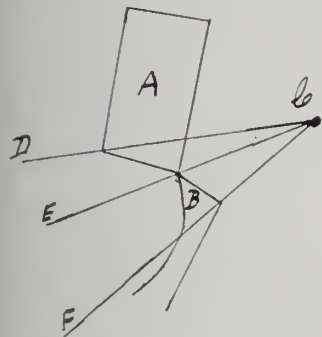

FIG. 9.

jewel, which contain the lifts, and also show the origin of the lifting angles.

ANSWER:—In Fig. 9 the pallet is marked A, and the escape wheel tooth is marked B, and the dot C represents the center of the pallet staff; the angle D C E is the angle of lift or impulse, for that part of the pallet jewels contained between the lines E C D, the source of the angle being at C, the pallet staff center. That part of the escape wheel tooth contained between the lines E C F is similarly the angle of lift or impulse face of the tooth; its origin is at C, the pallet center.

QUESTION:—Name the point from which the angles that govern the motion of the lever are measured.

ANSWER:—The pallet staff center.

QUESTION:—From what point is the width of the escape wheel teeth measured?

ANSWER:—From the escape wheel center.

QUESTION:—Name the origin of the angle which controls the width of a pallet jewel.

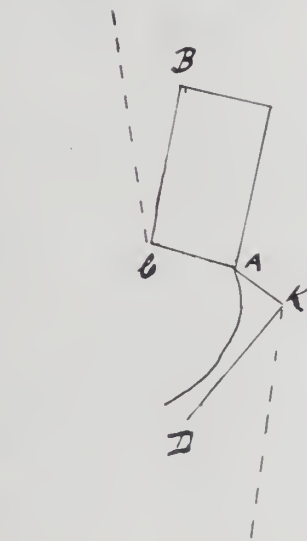

FIG. 10.

of the pallet jewel over which the tooth of the escape wheel slides. See Fig. 10, C to A.

QUESTION:—Explain the location of the locking face on a tooth of the escape wheel.

ANSWER:—The locking face of an escape wheel tooth is that part from K to D, Fig. 10.

QUESTION:—What is meant by the term "lift" or "impulse face" of an escape wheel tooth?

ANSWER:—It always refers to that part of the tooth as represented in K to A, Fig. 10.

QUESTION:—Locate the locking corner of an escape wheel tooth.

ANSWER:—The locking corner is that part marked K, in Fig. 10.

QUESTION:—What part of a tooth's locking face comes in contact with a pallet jewel's locking face when a tooth is locked on a pallet?

ANSWER:—The locking corner only.

QUESTION:—From what point is the locking face of a tooth measured?

ANSWER:—From the corner. See K, Fig. 10.

QUESTION:—To what is the pitch or slant found on the locking faces of pallet jewels due?

ANSWER:—It is due to the draft angle.

QUESTION:—What is the source of the draft angle on the pallet's locking face?

ANSWER:—It takes its origin from the corner C, Fig. 10, of the pallet jewel.

QUESTION:—What number of degrees generally represents the slant or pitch of the pallet's locking face?

ANSWER:—From 12 to 15.

QUESTION:—What is the use of the draft angle?

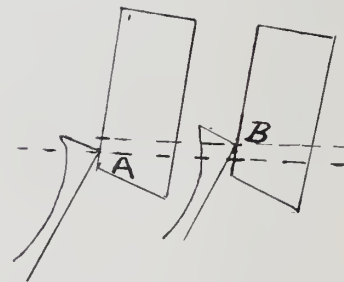

FIG. 11.

ANSWER:—Its office is to retain the lever against its bank.

QUESTION:—Is the draft angle a detriment?

ANSWER:—In a sense it is, as it adds to the unlocking resistance.

QUESTION:—What advantage is the draft angle?

ANSWER:—It insures the soundness of a part of the safety action, by keeping the guard pin away from the edge of the roller table.

QUESTION:—What is meant by the term "total lock of tooth on pallet"?

ANSWER:—It expresses the idea of the lever being at rest against its banking, and the tooth of the escape wheel being at rest at its highest point on the locking face of the pallet jewel.

QUESTION:—Of what is the total lock composed?

ANSWER:—It is the product of two locks, namely, drop or first lock, and draw or second lock.

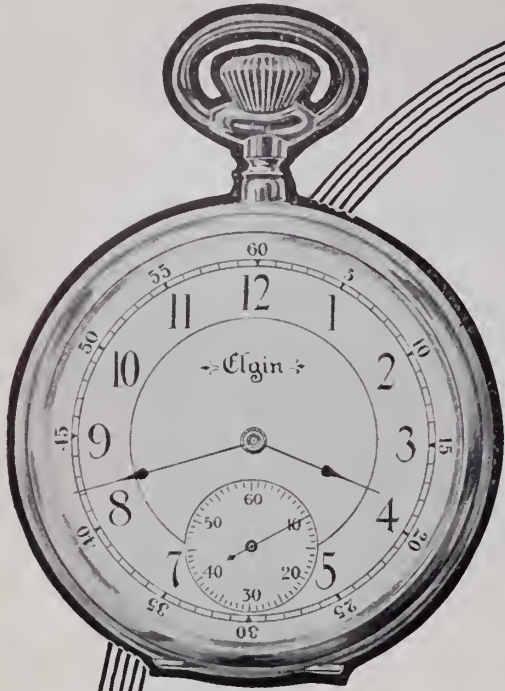

18
16
12

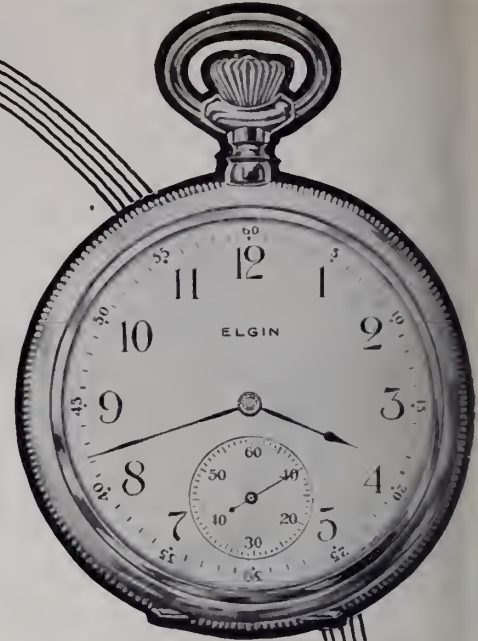

These are the mystic numbers that have made such a heavy increase in the demand for

The G. M. Wheeler Grade **ELGIN WATCH**

Made for years only in the 18 size—it became so popular with people wanting an accurate timekeeper at a moderate price that we were actually *forced* to make it also in thin models—16 and 12 sizes. Result—a tripled business!

DON'T be satisfied with a third of your share—carry the three numbers and reap the full advantage of the Elgin advertising.

See jobbers' list for prices
 or write the Company.

*Send for Elgin art booklets,
 "Timemakers and Timekeepers" and "The Watch."*

ELGIN NATIONAL WATCH COMPANY,

Factories: Elgin, Ill., U. S. A.
 General Offices: 131 Wabash Ave., Chicago.
 New York Office: 11 John St.

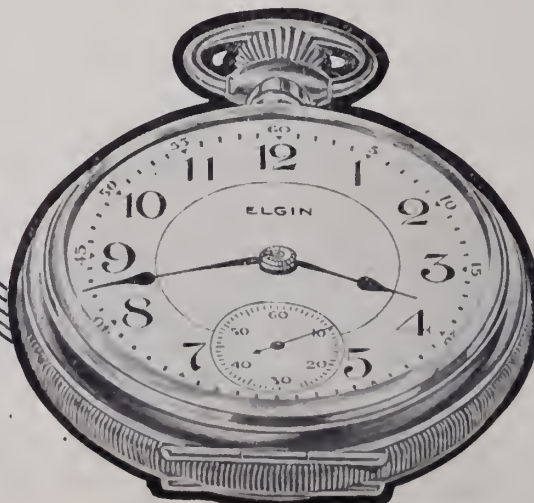

QUESTION:—What is expressed by the term "drop lock"?

ANSWER:—By drop lock we mean that point of contact of a tooth on the locking face of the pallet jewel at the moment a tooth drops thereon. This lock we have also termed the first lock, and it is illustrated at A, Fig. 11.

QUESTION:—From what point is the angle controlling the number of degrees of drop lock measured?

ANSWER:—From the pallet staff center. See A, Fig. 12.

QUESTION:—What do we mean by the term "draw" or "second lock"?

ANSWER:—Just as drop or first lock is

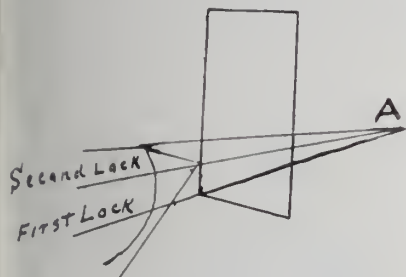

FIG. 12.

completed there occurs a descending motion of the pallet into the escape wheel which results in an increase of the lock. It is to this increase of the locking that we apply the term "draw" or "second lock." See B, Fig. 11.

QUESTION:—To what is this draw or secondary lock due?

ANSWER:—It is the direct result of the draft angle on the impulse face of the pallet jewel.

QUESTION:—What controls the extent of this second lock?

ANSWER:—The position of the banking pin.

QUESTION:—How much of the total lock

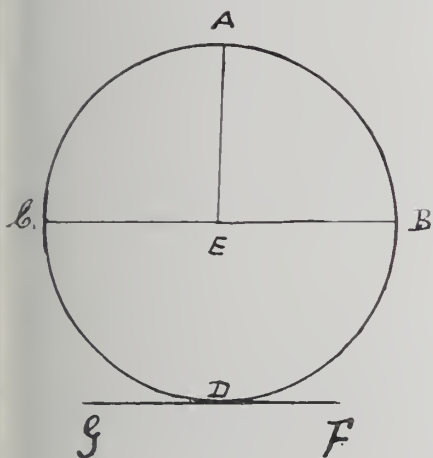

FIG. 13.

should be allotted to the draw or second lock?

ANSWER:—About one-fourth of the whole.

QUESTION:—What number of degrees should represent the total lock?

ANSWER:—About two degrees.

QUESTION:—From what point is the draw lock measured?

ANSWER:—From the pallet staff center. See A, Fig. 12.

QUESTION:—What is meant by the term "one degree"?

ANSWER:—The expression "one degree" always represents the 1/360 part of a circle.

QUESTION:—Of what may we consider a circle to be composed?

ANSWER:—Of a number of straight lines, their length of course varying according to the size of a circle.

QUESTION:—On a circle the size of the earth what is the length of one degree?

ANSWER:—Sixty geographical miles.

QUESTION:—On a circle whose circumference is 12 millimeters, what is the size of one degree?

ANSWER:—.10 millimeter.

QUESTION:—Does the term "degree" always express the same?

ANSWER:—Yes, in that it always stands for the 1/360 part of any circle.

QUESTION:—On what does the linear length of one degree depend?

ANSWER:—On the circumference of the circle of which it is a part.

QUESTION:—What is meant by the circumference of a circle?

ANSWER:—The line which bounds a circle is called the circumference. See A B C D, Fig. 13.

QUESTION:—To what does the term "diameter" refer?

ANSWER:—To a straight line passing through a circle and dividing it into two equal parts. B C is the diameter of the circle shown in Fig. 13.

QUESTION:—What is meant by the term "radius" of a circle?

ANSWER:—The radius of a circle is a line drawn from its center to the circumference. The lines A E, E B and E C are radii of the circle. See Fig. 13.

QUESTION:—Explain the term "tangent."

ANSWER:—A right line which touches a circle but does not cut it. See G F, Fig. 13.

QUESTION:—What is the abbreviation used for degree?

ANSWER:—^o is the sign used.

QUESTION:—What is a right angle?

ANSWER:—The angle A E B, Fig. 13, is such an angle. It contains 90 degrees, exactly one-fourth of the number of degrees in all circles.

QUESTION:—What are concentric circles?

ANSWER:—A series of circles varying in size, but having a common center. See Fig. 14.

QUESTION:—Illustrate by means of concentric circles the difference in the linear length of, say, 20 degrees.

ANSWER:—The lines A B C, Fig. 14, enclose an angle of 20 degrees on each circle. It will be noted that the space from D to F on the outer circle is greater than the distance from K to L on the inner circle, yet each space encloses 20 degrees. The diagram aptly illustrates that the linear length of a degree depends wholly on the circumference of the circle of which it is a part.

QUESTION:—What measurement is best adapted for the minute requirements of the watchmaker?

ANSWER:—The French or metric system.

QUESTION:—What metrical tools should every watchmaker possess?

ANSWER:—A gauge with sliding jaws, registering .1 or 1/10 of a millimeter, and

also a finer gauge, capable of measuring to .01 or 1/100 of a millimeter.

QUESTION:—How can we determine the linear length of a degree in any circle?

ANSWER:—By measuring in millimeters the circle's radius; this multiplied by two gives the diameter; the diameter multiplied by 3.14 gives the circumference of the circle in millimeters. Then by dividing this by

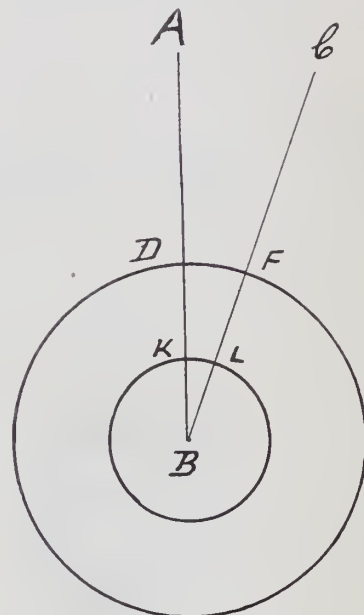

FIG. 14.

360 (the number of degrees in every circle) we obtain the linear length of one degree in millimeters or fractions thereof.

QUESTION:—Can we practically apply the above to estimate the degrees of pallet and tooth lock in a watch escapement?

ANSWER:—Yes.

QUESTION:—Explain the method we can use to estimate the number of degrees a tooth is locked on a pallet.

ANSWER:—In Fig. 15 we have before us pallets of the circular type. The locking

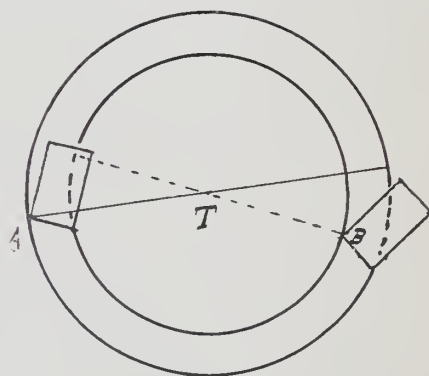

FIG. 15.

face of each pallet rests on a separate circle, the circles being concentric with a common center at the pallet staff. As we have two circles of varying circumference the size or linear length of one degree will vary for each circle; hence two calculations will be required to determine the linear length of a degree on each circle's circumference. We shall make our first calculation on an enlarged escapement, and estimate what two degrees of lock expressed in millimeters

Keystone Solid Gold Watch Cases



The Watch for Ladies and Misses



O size Open Face in Special Models

- ☐ Basic Plain Polish, Satin Finish, and Roman, with Antique and French Bows.
- ☐ Made in good substantial weights, and a wide range of prices.
- ☐ Engraved cases in a large and varied line of patterns.
- ☐ Made with swivel pendants, making an ideal case for use on Chatelaine pins.
- ☐ These cases fitted with 7 Jewel movements meet the demand for a popular price and reliable time piece.
- ☐ Write your jobber for prices.

KEYSTONE 14 K. SOLID GOLD CASES ASSAY

585-THOUSANDTHS FINE

14 K. GOLD ASSAYS 583 $\frac{1}{2}$ -THOUSANDTHS FINE

Trade-Mark



In back.

Note this Guarantee



In cap.

Look for



This tag.

THE KEYSTONE WATCH CASE CO.

NEW YORK

CHICAGO

PHILADELPHIA

CINCINNATI

SAN FRANCISCO

ould be; we have before outlined the rule. commence by measuring the radius of the outer circle. In our drawing the point T represents the pallet staff center and the point A is the lowest locking corner of the entering pallet jewel. A measurement taken from T to A gives us the radius as 30 millimeters. A like measurement of the outer circle, *i. e.*, from the pallet staff center to the lowest locking corner of the exit pallet T to B, Fig. 15, we assume is 25 millimeters. We have now obtained the diameters of each circle and shall begin to calculate the length, in millimeters, of two degrees of lock on the entering pallet. The radius being 30 millimeters, we multiply this by two, thereby obtaining the diameter, *viz.*, 60 millimeters. Multiplying the diameter (60) by 3.14 gives us 188.40 millimeters as the circumference of the outer circle; divide this sum by 360, the number of degrees in a circle, and we obtain .52 millimeters as the linear length of one degree on this circle. By multiplying this result by two we obtain 1.04 millimeters—the answer to the question, "What two degrees of lock on a circle whose radius is 30 millimeters?" The closest ordinary sliding-jaw gauge will express this point is 1. millimeter. By filing a piece of wire to this size and placing one corner of it at A, a comparison of the lock as it exists with our two degrees wire gauge can quickly be made. This method can be employed when we desire to make comparisons of the lock.

Our next problem is to determine the size of two degrees of lock on the discharging pallet. The radius we before determined as 25 millimeters, multiplied by two gives the diameter 50 millimeters. This we multiply by 3.14, the product being 157.0 millimeters, which equals the linear length of the circle's circumference. This amount divided by 360 gives us the linear length of one degree on this circle as being .43 millimeters; to obtain the size of two degrees of course multiply .43 by two. The answer, .86 millimeters, represents the size of two degrees of lock on the exit pallet's locking face. The nearest we can set an ordinary sliding-jaw gauge is 9/10. A close comparison of the lock can readily be made.

QUESTION:—Explain why two degrees of lock on the entering pallet measure 1.04 millimeters and the same amount of lock on the discharging pallet measures .86 millimeters.

ANSWER:—The discrepancy is due the varying size of the circles.

QUESTION:—In American watches would you expect the foregoing condition to exist?

ANSWER:—Yes; the pallets being of the circular type, there is naturally a slightly greater lock on the entering pallet, exactly as in the large model which we have considered.

QUESTION:—Supposing that in a watch escapement we find the distance between the lowest locking corner of the receiving pallet and the center of the pallet staff to measure $2 \frac{6}{10}$ millimeters, and that the distance between the lowest locking corner of the discharging pallet and the pallet staff center measured two millimeters, what type of pallet would be represented?

ANSWER:—The circular type of pallet.

(To be continued.)

The Dial.

THE dial, sometimes called the face, is without doubt one of the most important accessories of the watch, as much on account of its indispensable necessity for recording the time as on account of its convenience for decorative display. The principal object for which the dial has its existence is to indicate the hour in a plain, readable manner, and without confusion. For this reason, the ornamenting of dials has been almost entirely abandoned in modern watches.

The dials of the first watches were made of gilt copper, of silver and sometimes of gold, engraved with the hour figures in relief rising from translucent enameled surfaces of various colored combinations, admired for the beauty of their designs, the motives of which excelled by their originality, calling to mind manuscripts of the middle ages.

These dials furnished by their value admirable works of art and contributed largely to the beauty of the watches of the Renaissance period.

Since the 16th century dials were made entirely of enamel. The rich collection of Messrs. Paul Garnier and Olivier contain several rich specimens of the watches of this epoch. But it was only towards the end of the 17th century that the use of the so-called enameled dial became general. The dials of the times of Louis XVI. were made most artistically and with a perfection which it would be difficult to reach in our time. Some of the more distinguished ones were inscribed with the maker's name, "Cotteau," several of which were adorned with delicate incrustations of gold and small rose diamonds set in enamel between the hour figures as a relief.

Very often colored enamels were largely employed in artistic designs and appropriate shades. For instance, the center of the dial was of a beautiful royal blue bordered by a slender ribbon of white, fringed with gold, enclosing the name of the maker of the watch painted in delicately proportioned letters. Others which were known by the name of "Queens" dials had the hour figures placed vertically instead of radiating toward the center.

As has been stated elsewhere, the revolution before the first Empire and the year 1830 brought about the practice of making dials with high colorings, showing emblems relating to events of patriotism and political developments of the period enlivened by sentimental inscriptions.

Very flat watches, which were in fashion during the time between the years of 1830 and 1840, compelled the use of very thin dials, sometimes engine turned. The introduction at the same time of styles which offered the advantage essential in flat watches to afford more room to the train brought about the liberal use of dials with eccentric hour circles.

A large number of verge watches in use during the years between 1820 and 1830 had dials of copper stamped with ornamental designs and with enameled figures, which dials had no artistic value. During this same time dials were made of silver and even of gold, ornamented with figures representing religious subjects.

The extreme flat watches mentioned above had the cylinder escapement. But before the introduction of these the more bulky watches had convex dials, which afforded the necessary vacant space for the accommodation of dial wheels or for any caducature mechanism, such as repeaters or clock watches. In modern watches with flat dials such mechanism, etc., is generally placed in more or less extensive recesses provided in the thickness of the plates, where bars are used for the accommodation of the upper bearings of the train.

It has recently been proposed to divide the dials of watches into 24 hours, but without much success. While such a division might be practicable for clocks, it becomes otherwise in moderate-sized watches in use at the present time, which would cause the placing of the figures too close together.

As to a decimal division, which has also been advocated by scientists for facilitating calculation, it would seem to be too radical a change and too revolutionary for use in daily life.

Roman figures have been used principally in the marking of hours. Arabic figures were for a time used only during the first Empire and towards the end of the reign of Louis XVI. Their exceptional use is in order where several concentric dials are required as in alarm and other timepieces.

The manner of counting time has not always been the same with all nations, and, according to information furnished by Mr. Arguembourg, of Paris, an expert in everything appertaining to the measurement of time, the Japanese system of counting time differed materially from ours. The following details are given:

"Formerly the Japanese custom was to count the time which elapsed between two risings of the sun. They divided the day into six hours and the night into six hours. In this way each one of their hours represented two of ours; their half hours were equal to our full hour.

At the first hour of the day, which corresponds to our midday, the striking clock strikes nine blows. At the second, which represents two of our hours after noon, eight blows are struck, and so on until the fifth hour, which represents 10 o'clock in the evening of our time, for which the striking mechanism strikes four blows. The night hour begins at midnight. The halves of the hours are indicated alternately by one or two blows—one blow after each uneven hour and two blows after every even hour.

"Every Japanese hour is named after some animal—noon, after the horse; two o'clock, according to our time, after the deer; four o'clock, after the monkey; six o'clock, after the cock; eight o'clock, after the dog; 10 o'clock, after the boar; midnight, after the rat; two o'clock, after the bull; four o'clock, after the tiger; six o'clock, after the rabbit; eight o'clock, after the dragon, and 10 o'clock, after the snake."

Burglars recently entered the store of S. Sumarladason, Seattle, Wash., and stole \$500 worth of stock.

G. V. Warnke, Toledo, O., has moved from 1637 to 1635 Broadway, and has opened up a newly remodeled store with attractive showcases and fixtures.



THE ROCKFORD WATCH
for ALL CLASSES

"True Time for a Life Time."

Rockford Watches

The Most Profitable and Satisfactory
Watch for the Legitimate Jeweler.

WRITE TO-DAY FOR PRICE LIST AND ADVERTISING MATTER

ROCKFORD WATCH COMPANY, ROCKFORD, ILL.

The New Continental Watch Co.'s Movements.



0, 12 and 16 Size. 7 to 21 Jewels.
All Bridge Model and Pendant Set.

Fitting all American cases without any change, interchangeable pendant set, have steel scape wheels, exposed pallets, double roller, Arabic or Roman dials, with and without marginal figures. CONTINENTAL WATCH CO. on bridges, C. W. CO. on dials except otherwise ordered. Special name or nameless movements require four months' time for delivery. Packed in glass show box inside paper box. No expense has been spared to make these movements the best on the market for the money. Every movement absolutely guaranteed. A full line of finished material constantly on hand.

For Sale by all Jobbers.

JULES RACINE & CO., Exclusive Importers,

103 State St., Chicago.

37 MAIDEN LANE, NEW YORK.

HOROLOGICAL DEPARTMENT

BRADLEY POLYTECHNIC INSTITUTE
Formerly Parsons Horological Institute
PEORIA, ILLINOIS

LARGEST AND BEST WATCH SCHOOL IN AMERICA
We teach Watch Work, Jewelry, Engraving
Clock Work, Optics. Tuition reasonable. Board
and rooms near school at moderate rates.
Send for Catalog of Information

Learn Watchmaking

Refined, profitable labor. Competent men always
in demand. We teach it thoroughly in as many
months as it formerly took years. Does away
with tedious apprenticeship. Money earned while
studying. Positions secured. Easy terms. Send
for catalogue. Address

St. Louis Watchmaking School, St. Louis, Mo

PRACTICAL COURSE IN ADJUSTING

Published Price, \$2.50.
Special Reduced Price, \$1.50, Postpaid.
All Jobbers or Jewelers' Circular Publishing Co

ESTABLISHED 1887

DUBOIS WATCH CASE CO.



Manufacturers of

Fine Solid Gold Watch Cases



Specialties in Casing of

CHRONOGRAPHS, REPEATERS AND ALL KINDS OF COMPLICATED WATCHES

NEW YORK OFFICE:
21-23 Maiden Lane

FACTORY AND MAIN OFFICE:
316 Herkimer St., Brooklyn, N. Y.

??

HAVE YOU SEEN THEM ?

??

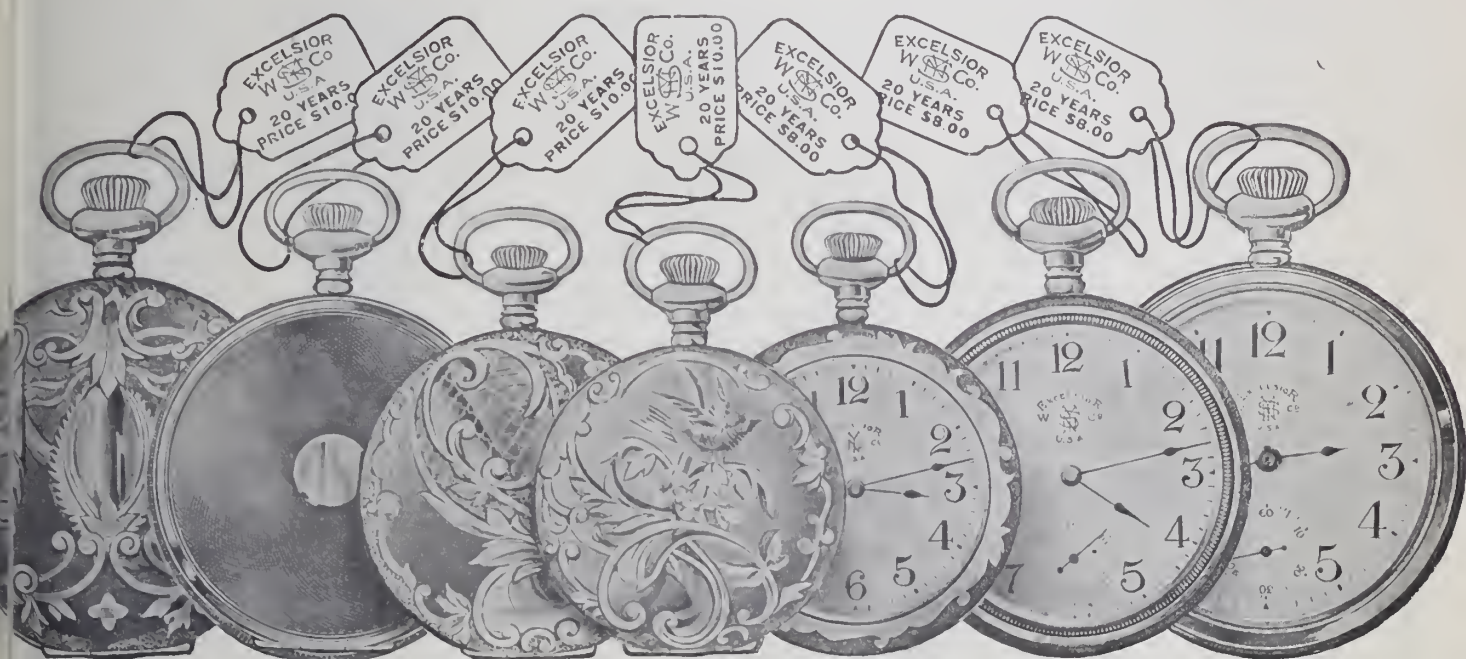

If not, ask your Jobber for the new line of

Excelsior Watches

Made Especially for the Jeweler

In 6, 12, 16 and 18 Size Open-Face and Hunting

Furnished as Complete Watches only in	{ 20-year Gold Filled { 10-year Gold Filled { Silverode	Factory Tag Showing Price on
		Each Watch

GOOD PROFITS IN THEM FOR YOU

Three quarter Plate, Nickel Damaskeened, Nicely Finished Throughout, Specially Timed, 7 Jewels, Quick Train with Bearings in Metal Settings, Cut Expansion Balance, Breguet Hairspring, White Enamel Dial.
 Every Watch is STEM WIND and PENDANT SET (excepting the 18 Size Hunting, which is LEVER SET)

All are THIN MODELS
 All are "Timed in Case" at the factory
 All sell at "Fixed" prices Everywhere

If you have mislaid your Trade Booklet, write for another copy NOW

NEW YORK STANDARD WATCH CO. JERSEY CITY, N. J.



The above TRADE MARK is well known to you, because it is on every watch and watch movement made by the LANGENDORF WATCH CO.

The more of our large line you carry in stock, the more profitable and satisfactory are

YOUR SALES

Perfect Interchangeability of parts renders repairing easy.

Do not accept substitutes, but insist upon getting the genuine L. W. Co. make. It's far the cheapest after all, as the quality is such you may

DEPEND UPON

If your jobber cannot supply you with

THE RIGHT KIND of GOODS

write to the Sole Agents for the United States,

AMERICAN-SWISS WATCH CO.

1 Maiden Lane, New York
CUSHMAN BUILDING

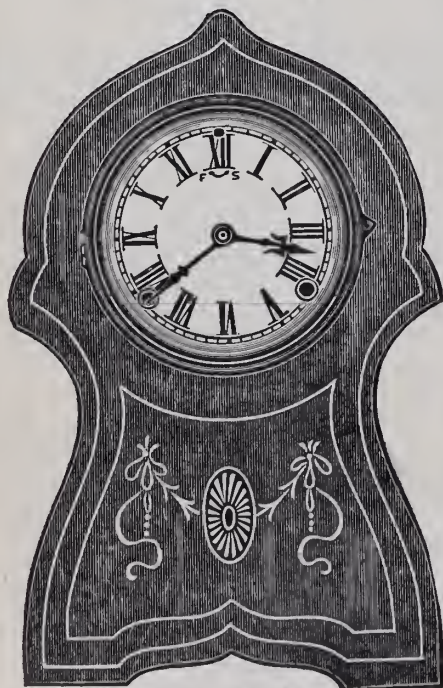

MANCHESTER
Height 13¾ in. Width 8¾ in.

SESSIONS CLOCKS

Superior Finish
Popular Prices

We have added a number of fine marqueterie cabinet clocks to our line which will interest you.

The Sessions Clock Company

FORESTVILLE, CONN., U. S. A.

New York Salesroom, 37 Maiden Lane

HALL CLOCKS



Elliott's
Celebrated
Tubular
Chimes

**HARRIS &
HARRINGTON,**
12 BARCLAY ST.,
NEW YORK

Sole Agents to the Trade
for
J. J. ELLIOTT & CO.
LONDON.



THE  OIL
NEVER
GOES
WRONG

The trade from ocean to ocean is praising this wonderful oil. IT POSITIVELY WILL NOT GUM. Can you say as much for the oil you are using? Send 25c. to your jobber for a bottle, and end your oil troubles.

RANLETT & LOWELL CO.

SOLE MANUFACTURERS
Jewelers' Building BOSTON, MASS.
Wholesale Selling Agents
M. SICKLES & SONS . . . Philadelphia
SWARTCHILD & CO. . . Chicago
NORDMAN BROTHERS CO., . . San Francisco
D. C. PERCIVAL & CO. . . Boston
CHAS. MAY & SON . . . Boston
DANIEL PRATT'S SON
53 Franklin Street, Boston
SUSSFELD, LORSCH & CO., . . New York City
H. S. MEISKEY CO. . . Lancaster, Pa.

HERMANN GRABEMANN

Reliable Watch Repairing

My work you can call your own

Trade References furnished A trial solicited

81 NASSAU ST., NEW YORK

WATCH REPAIRING FOR THE TRADE

Careful, Reliable, Prompt Work. Trade References. Price List on Request.

A. D. PAPAZIEN

71-73 Nassau St., Cockroft Bldg. NEW YORK

JULES JÜRGENSEN
Watches and Chronometers
PARIS—"THE GRAND PRIX"—1900

SOLE
RUDOLPH & SNEDEKER
65 Nassau St., New York
AGENTS

REMOVAL

FROM

PHILADELPHIA to NEW YORK

No. 35 MAIDEN LANE

Wm. C. Penfold Co.

Largest Exclusive Watch Jobbers in New York

OF

Dueber-Hampden Watches Dueber Cases—Hampden Movements

A COMPLETE LINE ALWAYS ON HAND

Mail Us Your Orders

There will be little sale this season for high price Watches. The big demand will be for a medium priced article. The **only** medium priced, high grade watch is the

New England

Nothing takes its place. Are you handling the *New England*? If not, write to-day for Price List and get in position to satisfy the demands of your trade.

The New England Watch Co.

Chicago

WATERBURY, CONN.

San Francisco

STORE KEEPING DEPARTMENT

That this department shall prove mutually beneficial to our readers, it is desirable that the members of the trade generally communicate with THE JEWELERS' CIRCULAR-WEEKLY regarding any advantageous device or plan which they are utilizing in connection with their business.

How to Meet the Competition of the Mail Order House.

(Continued from issue of Feb. 5.)

If every retailer would but realize that his own community can be built up in population and wealth, and that, as it is built up, his own business also increases, he would become a hard and constant worker for his city. And with every advance he would become a stronger competitor to mail-order houses. He would soon be able to supply every want of the people in his line, thus taking away the greatest excuse for sending outside his town for goods.

Almost every order which goes to a mail-order house includes goods which could be bought at home. But people, ordering some one thing they cannot get at home, think they may as well add a few other things to make the order amount to something. And they just include everything they need at the time.

If you can build up your town to a point where you can afford to carry a large stock, you at once take away the temptation to order outside.

By all means join the other merchants of your town in an effort to develop the natural resources. Very few towns exist, today, which do not have some natural resources which should be developed, and such development would bring more business to every one in the town.

The town may be so located that it has the advantage of water transportation, and still not be using this advantage.

Of course, if you happen to be in a mining district the mines are being exploited, but there is always other development possible.

Possibly your town is located near a stream which can be dammed and thus made to develop a large amount of electric power, which can be sold very cheap. This would induce all kinds of factories to locate there.

Possibly you have mineral springs, or other health giving natural resources, which can be developed into a regular health resort.

Possibly you have a good vein of coal under your section, which will furnish work to hundreds of people if developed.

Possibly you have natural gas, and by offering cheap fuel you can get many factories to locate in your town; if oil is struck it can be used to induce the location of refineries.

Perhaps your locality has a fine clay, good for china ware, pottery or brick.

You may have a cliff of limestone of a splendid quality for making cement, and by its proper exploitation may be able to get a factory erected which will employ 500 or more men.

Even a good grove of trees can be developed, with advertising, into a pleasure resort and be made of great benefit to a town by drawing the entire surrounding country there in search of pleasure.

Remember, however, that you must have manufacturing enterprises if you would build up your town. Find out every natural resource you have and join in getting it developed. Natural resources are of no value otherwise, and it is well for your town to be the first in development in your section.

If you are suffering from mail-order competition it may be a good plan for you to search within yourself. See whether you are not to blame for at least a part of the trade going elsewhere. Few men are now living who could not better themselves by looking themselves over occasionally. We are all too prone to think that the thing we do is right, whether it is right or not. Remember that your mail-order competitor is a good merchant, and you must also be a good merchant if you compete successfully.

To be a good merchant, you must keep thoroughly posted on everything in your line. Just to show how a merchant can fool himself into the belief that he is the most progressive man in town, the following incident may be taken as an illustration.

A merchant in a small city went to his wholesale center this Spring to buy goods. Following out his usual custom he closely observed the window trims of the city retailers, so he could put in something new and attractive when he got home. One window especially appealed to him, and he studied it carefully. When he got off the train at his home station that window trim was still running through his mind. And as he walked past the store of his most progressive competitor he was astonished to find his window trimmed exactly as the window he had examined in the large city. This was a puzzle, as he knew absolutely that no other merchant from his city was in the wholesale market that week.

Going into his office to look over his mail he glanced through his letters, then opened several trade papers which had been accumulating since before he left for the market. On opening one which he should have read a week before he left he saw a picture and full description of this same window trim, and at once knew that both his com-

petitor and the merchant in the large city had followed up this description.

He learned by this that it always pays to read the trade papers thoroughly at the earliest opportunity, and to put new suggestions into practice at once if good is to be gained from them. Also, that on account of the trade papers, the merchant in the smallest place can keep his stock and store as much up to date as the merchant in the big city if he will but put forth the effort.

While the trade paper is eagerly scanned by the city retailer for the very latest ideas too many country dealers fail to read them carefully. And just in proportion to their neglect in this direction will they usually be found behind the times. Being behind the times does not worry a good many merchants, and that is where they make a very serious mistake. Let us take just one instance. It is in such stores that traveling salesmen always manage to sell all the old patterns, brands and grades of goods. This soon makes the store a dumping ground and people do not go to such places to buy new goods.

The trade paper, if well and promptly read, will help you to have some judgment in your buying, as well as in your selling.

(To be continued.)

An Attractively Designed Advertisement.

(See advertisement illustrated on page 99.)

AN original conception in retail jewelry advertising is illustrated on page 9. This ad. was used by the G. W. Meyer Jewelry Co., 822 Market St., Chattanooga, Tenn., in the Chattanooga News, about two weeks before Christmas. Only part of the advertisement is illustrated, the main design having been reinforced on either side by panels bearing the name of the advertiser in large type printed in red. The space occupied by the whole announcement was 15 inches by 16 3/4 inches. The accompanying design has been reduced from 11 inches by 14 inches, and was partly printed in red.

The ad. was designed to advertise chief gifts for women, although here and there in the drawing will be seen an odd trinket for mere man. The text lacks force and does not do justice to the extremely clever line drawing. Oriental jewelry and other kinds of novelties may be exploited with excellent effect by means of this clever design. It also lends itself well to the advertising of wedding gifts. Livermore type, or some other artistic letter would allow of most attractive typographical make-up of the mortise.

R. F. N.

Storekeeping Department.

The Man of The Hour in Business.

WHEN a noted alienist remarked recently that most pre-eminently successful men, while not exactly insane, are close to the border-line because their minds are abnormally developed, the public was severely shocked. Here was a man, admittedly an authority on such matters, virtually declaring that genius indicates a lack of mental balance.

At first thought it would seem that, expert or not, he would bring down upon his head a torrent of ridicule. Yet no keen observer attempted to dispute the statement, and, like as not, none will. Because, to shine effulgently in modern life, one must perforce have a pronounced personality, an individuality all his own, some quality so highly developed that he's a marked man among his fellows.

Sometimes one is endowed with peculiar gifts. We have probably all seen the mathematical prodigy who could run his glance over six columns of figures but once and immediately give the correct total. Occasionally it is an acquirement, due to years of application and study of a particular subject.

One man, when occasion arises, calls a score of plough-boys from the fields, boys who never handled a gun, and converts them in short order into a company of able warriors. Another is capable of uttering about him masterly executives who conduct a chain of enterprising newspapers so capably and profitably his own efforts are needless.

Now, every man knows his strength as well as his weakness. The tendency in business is altogether too strong to ignore or subdue one's innate powers. Men are inclined to suppress those intellectual or social distinctions which make them conspicuous, oftentimes because they are the subject of comment not altogether agreeable, and there is thus a general merging toward a common mould, until many are much alike in manners, thoughts and capabilities.

But the man who hopes to become notably successful can ill afford to stifle his personal points of prowess. He must be a man different from other men, and so different that it's noticeable either in contact with him or in the nature of his works.

Another way of looking at it: Unless you are the exception there is some direction in which you can, eventually, attain pre-eminence, if only your more potent faculties are properly cultivated. Doubtless you know what these are better than any one could tell you.

Past performances may show it. Decided preferences are not always reliable. There is a glamour about certain professions and a fascination in others that appeals to most every man at one time or another. There's a work for you.

Of old one said: "Know thyself." Later-day conditions require the same knowledge and its faithful application. In brief, the specialist—even though he borders on insanity—is the man of the hour in the realm of business.—*The Haberdasher.*

A Representative Retail Jewelry Store of New England.

ONE of the most artistically furnished stores in New England is that of the F. L. Wilson Co., Danbury, Conn., an illustration of which is shown below. The store is 125 feet deep and 21 feet wide, with two large show windows, the entrance being in the center. At the right as one enters the store is the watch repairing room, on the left is the diamond room. In the center of the store is a horseshoe show case running the full depth of the store, while on the sides are the wall cases. All the woodwork is of solid mahogany, and great care was taken in the selection of the wood, and also to have the grain of one side match the grain on the other. All fancy ornamentation was carefully avoided so as to leave

electric lights, and below this, forming the top of the inside of the case, is one large piece of ground glass through which the electric light is diffused. This gives an even light throughout the entire case, avoiding the sharp glare of the electric light and all shadows. No portion of the wall is exposed to view below the top line of the wall cases, a large mirror being between each case. In all there are 855 square feet of mirrors in this store.

In the front of the store, on either side, are two long settees, the backs and the seats being of one massive piece of mahogany. The window slopes are also of one piece of the same hard wood. All the fixtures and furnishings were planned and designed by F. L. Wilson and made under his personal direction, and while it took a long time to secure the large pieces of mahogany



INTERIOR VIEW OF THE ATTRACTIVE STORE OF THE F. L. WILSON CO., DANBURY, CONN.

no places for the collection of dust, with the result that the woodwork is kept highly polished and gives a rich and dignified appearance.

Throughout the entire store wherever it was possible to use one piece of wood this was done, which is also true of the glass and mirrors. The frames of the wall cases and the woodwork below are each of one solid piece, as are also the show cases in the center and the glass tops and fronts. To illustrate to what extent the scheme of avoiding pieced work has been carried out, the large horseshoe case in the front has but one piece of glass for the top and one piece for the side. Most cases of this kind have a bar through the center and the sides made of two or three pieces of glass. Another feature of the show cases and wall cases is that the bottoms are flush with the glass, no part of the frame showing above the floor, thus avoiding any shadows and giving full light to all portions of the cases.

In the lighting of the wall cases a novel arrangement has been employed. In the top, in a separate compartment, are the

and make the fixtures according to Mr. Wilson's ideas, the results more than justify the time and money expended.

The stock in the cases is very attractively arranged, there being an especially fine display of cut glass and silverware. In the rear of the store is a work room for the manufacturing and repairing department, which is equipped with the latest electrical machinery.

W. E. Rickett, a watchmaker with the Hickox, Maynard Co., Albuquerque, N. Mex., has invented a device which is intended to turn off or on the electric current used for illuminating purposes at any time desired.

Burglars, about a week ago, smashed the plate glass window in the store of David H. Keene, 10th and Main Sts., Fort Worth, Tex., by means of a large rock, and escaped with several hundred dollars' worth of miscellaneous jewelry. The value of the window alone is estimated at \$150. A reward of \$25 has been offered by the jeweler for the recovery of the stolen stock and the arrest and conviction of the thieves.



RETAIL JEWELERS ADVERTISING

Heavy Spring Buying and Extensive Advertising the Harbingers of Renewed Prosperity.

THE recent resumption of heavy buying in the wholesale market and unusually extensive advertising on the part of retail dealers have acted as a cinching argument

Contrary to previously existing opinions, it has already been demonstrated that the purchasing public now believes that it can buy to the best advantage from the mer-

the advertising done by the advertiser. Now there is no existing doubt that the extensive advertiser is the most careful buyer and consequently the cheapest seller of merchandise.

It took some time to prove this truth, but continuous advertising accomplished it very effectively. As a result retail jewelers as well as others are purchasing space very generously.

The present month gives the jeweler unusual opportunities for the exploitation of his wares, owing to the two legal holidays, Lincoln's and Washington's birthdays, and the valentine season just passed. Besides valentines, which are frequently carried by jewelers, numerous other trinkets, suitable as gifts to be awarded by arduous lovers, are disposed of. Enterprising jewelers now purchase among other stock small novelties

Winter 1876
Pre-Inventory Reductions on
DIAMONDS
All kinds of diamonds reduced
At 25% below retail prices
G. G. Winter Jewelry Co.
502 N. CALLETT AVE.

Spring Announcement
W. C. Graves & Bro.,
Opposite Post Office Building

Society Emblems
of all the different orders, pins, buttons and charms. Class pins and special designs to order at short notice.
C. HOWARD DALEY & CO., JEWELERS—
259 Main St. - Tel. 532

QUALITY
TODAY IS THE LAST DAY TO TAKE ADVANTAGE OF THIS GREAT SALE
20% REDUCTION SALE
L. W. SUTER
JEWELER, SILVER AND OPTICIAN
515 1/2 N. 3rd St. - Tel. 1111

BIRKS and DIAMONDS
Are Synonymous Terms
Henry Birks & Sons LIMITED
DIAMOND MERCHANTS.
GEO. E. TROLEY, Managing Director

Diamond Rings Reduced
Hand Made Settings
We have now many diamond rings and will sell fine quality Tiffany Setting Rings—
1/4-Carat Rings \$10
1/2-Carat Rings \$20
3/4-Carat Rings \$35
1-Carat Rings \$50
1 1/2-Carat Rings \$90
all fine crystal colors, perfectly cut diamonds 25% less than you have ever bought them.
LEBOLT
STATE AND MONROE STS.
Palmer House Corner

Our Big January Discount Sale...
AFTER such a busy Holiday season as we have just passed through it isn't any wonder that our stock needs re-adjusting. Certain lines have to be reduced in order to accomplish this—and so we announce our January Clearance Sale.
While the greater portion of these offerings are goods purchased for our Holiday trade—yet the great majority of them are seasonable, all-year-round—quite as desirable three or six months hence as they were during the Holiday season or at the present time.
Study these various offerings. Make up your mind to secure some of them. Be on hand early tomorrow morning to get your share.
Diamond and Other Classes of Beautiful Jewelry Offered at a Discount of 10 Per Cent.
SOLID GOLD LOCKETS
SOLID GOLD THIMBLES
SOLID GOLD WATCHES
SOLID GOLD WATCH CHAINS
And many other articles in **SOLID GOLD.**
These Goods at 20 Per cent. Discount.
SOLID GOLD SIGNET RINGS
SOLID GOLD GENT'S SET RINGS
SOLID GOLD LADIES' SET RINGS
SOLID GOLD PLAIN RINGS
SOLID GOLD EMBLEM RINGS
These Goods at 25 Per Cent. Discount.
ALL SILVER PLATED WARE
ALL GOLD PLATED JEWELRY
ALL CUT GLASS, ETC.
ALL HAND-PAINTED CHINA

Our Diamond Business
Last year was the largest in the history of our house. Amounting to nearly one-fourth of our entire business. Several reasons for it. The size and variety of the stock had much to do with it. The uniformly fair prices also helped. Our reputation, sustained through two-and-a-half years, was probably an important factor, and then a constantly rising market had its effect. But whatever the reason, it was a gratifying result, and we hope it will be repeated this year.
HIGHT & FAIRFIELD COMPANY

Twenty Per Cent. Off
The special **CLOCKS AND CLOCK SETS**
ranging in price from \$18.00 to \$43.00 are beautiful and cannot be duplicated at the price. On these we are offering a discount of 20%.
Arthur M. Field Co. JEWELERS
Corner Church Street and Palace Ave. ASHLVILLE, N. C.
Eighty Cents Buys One Dollars' Worth

How About Your Old Gold?
BERENS
Quality and Optics. 1110
1111 Broadway, New York

Special Values in Clocks
R. C. Greer's Son
a South Centre Street

Diamond Jewelry
Lawrence L. Moore Co.,
705 Second Avenue, Seattle

New Back Combs
Kofman's
Prices from \$2.00 to \$15.00
78 North High Street

DIAMONDS
M. J. Beuchler

Feaster Bros

A MISCELLANEOUS COLLECTION OF RETAIL JEWELERS' ADVERTISEMENTS USED DURING THE MONTH OF JANUARY.

in favor of prosperity and brisk trade and done much to dispel the haze of pessimism which for a time threatened to settle in certain quarters.

chant who does the most extensive and judicious advertising. It is not so very long ago that an impression prevailed among many that the purchasing public paid for

in gold and silver which can be sold at very low price, and these are mounted tastefully on heart-shaped cards of any color desired, the leading colors being red at

Retail Advertising Department.

white. This bit of enterprise never fails to liven the sales. The show window on this occasion is also not forgotten, and attention is called to it in an advertisement, thus increasing the strength of the impression made upon the reader.

Washington's birthday also allows the jeweler to show the public that he is a progressive citizen by making a timely window display. A display of this character, which is both simple and inexpensive, appeared in the Anniversary Number of THE JEWELERS' CIRCULAR—WEEKLY, issued Feb. 5, last.

The advertisements illustrated herewith are mostly of a general character, and do not advertise goods suitable for any special holiday.

The advertisement of the R. G. Winter Jewelry Co., Minneapolis, Minn., calls attention to a pre-inventory reduction in diamond jewelry, and was used in a space of 1/2 inches, single column.

W. C. Graves & Bro., Memphis, Tenn., in a space of four inches double column, announce desirable purchases by the head of their firm and dwell upon the suitability of recent acquisitions as Easter gifts, etc. Badges and emblems are advertised in a space of 2 3/4 inches by C. Howard Daley & Co., Danbury, Conn.

Reduction sales tend to make surplus stock move rapidly and serve, too, as a timely tonic for sluggish post-holiday business. L. W. Suter, Seattle, Wash.; the Arthur M. Field Co., Asheville, N. C., and Mack the Jeweler, Paris, Ky., are advertising reduction sales at the right time. The typographical arrangement of the Suter announcement, which has been reduced from 1/2 inches double column, is much more attractive than that of the Field ad. The text of the latter, however, is very convincingly written, and the advertisers have chosen a good special to feature at the present time. The ad. of the Field Co. was used originally in a space of six inches double column. A wag who handed Mr. Mack's announcement to the reviewer remarked that its report of a January discount sale was so noisy that it could almost be heard. This is not at all disparaging, but rather laudatory of the announcement's catchiness. The tocsin and fantastic tinsel illustrated on the right make a striking ornament for a New Year's announcement, and is no less apropos in announcing the January sale. But the typographical display of this ad. is not at all pleasing to the eye. The makeup would be improved were the articles enumerated, such as "solid gold locket," etc., set in smaller bold-face type, and arranged one under the other. The sentence above this—"Diamonds and other classes of beautiful jewelry," etc.—might be printed in Livermore type or even in a light-face type to contrast with the list of articles printed below. The space occupied by this ad., which was published Jan. 18 in a local daily, was 10 inches triple column.

Henry Birks & Sons used the accompanying advertisement in a recent issue of a Vancouver daily to advertise their establishment in Vancouver, B. C. The advertisement aims merely to demonstrate the

high class tone of the concern's diamond department.

The advertisement of the Hight & Fairfield Co., Butte, Mont., suggests a happy spirit of optimism and would undoubtedly have proven even more satisfactory had a few specials been advertised under this introduction.

Lebolt & Co., Chicago, announce a special sale of diamond rings in a space of seven inches double column. The typographical arrangement of this ad. is quite good.

The present little announcement, reduced from four inches single column, lays stress on diamond jewelry in a general way, no prices or special articles being mentioned.

Hair ornaments are engrossing the attention of the fair sex at the present time, and the Hofman Jewelry Co., Columbus, O., is taking advantage of this fact by advertising combs. The present ad. was used in a space of 4 1/2 inches double column.

The ad. of Max J. Beuchler, Bridgeport, Conn., occupied a space of only 2 3/4 inches

NO
MATTER WHAT
IT IS, IF YOU WANT IT FOR
"HER"
You're sure to find it at
MEYER'S
And you'll find the price low
enough to suit you.
The Largest and Finest Stock of High Grade Jewelry
in the Entire South.
G. W. MEYER JEWELRY CO.
822 MARKET STREET.
Write for our Catalogue. Mail Orders
Filled Promptly.

A STRIKING ADVERTISEMENT USED BY THE G. W. MEYER JEWELRY CO., CHATTANOOGA, TENN.
(Reviewed and described on page 96.)

Those desiring to turn into cash old-fashioned trinkets of gold will be attracted by the four-inch single-column ad. of the Berens Jewelry & Optical House, Bellingham, Wash.

R. C. Green's Son, Pottsville, Pa., last month, made a special feature of all kinds of clocks from the cheaper to the more expensive ones. The window display bore out the statement in the advertisement, which occupied four inches double column.

The ad. of the Lawrence L. Moore Co., Seattle, Wash., is always identifiable by the trade-mark, consisting of the design of a lion whose head is surmounted by a dia-

single column. Notwithstanding its small size, it is attractive and well constructed.

Feaster Bros., Keyser, W. Va., evidently believe in keeping the reader's mind in suspense, as indicated by the manner in which they use their present space of 4 1/2 inches double column. The "suspense" method of advertising is hardly one to be recommended as a means of advertising jewelry in newspapers. It is best adapted to street car or billboard advertising. The retail jeweler will find it most profitable to say something about his stock every time his ad. appears in the space for which he pays his good money. R. F. N.



HERPERS BROS.,
MAKERS OF
SETTINGS
IN 10, 14 AND 18 KARAT GOLD
AND IN PLATINUM
ALSO A COMPLETE LINE OF
GALLERIES AND FINDINGS

"SWASTIKA"
Plain and for Enamelling
IN THREE SIZES

OFFICE AND FACTORY
NEWARK, N. J., U. S. A.

NEW YORK BRANCH
41-43 MAIDEN LANE

JANITSCHKE COMPANY, Inc.
33 UNION SQUARE, NEW YORK CITY

Manufacturers of Patented **DIES** for the Silver and Metal Trade

ARTISTIC CASTINGS OF EVERY DESCRIPTION
FOR THE SILVER AND JEWELRY TRADE

Iron Hubs and Bronze Forces, False Core Work and Undercut Castings with Elastic Patterns. Fine Plaster Castings by the *Janitschek Patent* Superior to the Asbestos Process

TELEPHONE, 400 STUYVESANT



A Small Compound Sand Blast

Price, \$20.00 Foot Bellows, \$6.00

WORKS AS EFFECTIVELY WITH FOOT BELLOWS AS WITH POWER BLOWER : : : :

MADE of Galvanized Sheet Iron, 10 inches diameter, Glass Top, Fittings of Brass and Iron, practically indestructible. Satisfaction guaranteed. Ask your Jobber for it, or write to us. Other Specialties: Zeuner's Best Jewelers' Saws; American Swiss Files, equal to the best imported; Gas Furnaces, for Melting, Annealing, etc., etc.; Positive Pressure Blowers.

E. P. REICHHHELM & CO.
JEWELERS TOOLS, FILES AND SUPPLIES
24 JOHN STREET, NEW YORK



LEIMAN'S PRESSURE BLOWERS
For Blowpipe Soldering, Melting, Sandblasting, Annealing, or wherever a blast of air is required at pressure

NO Springs Fiber Tips Delicate Parts } **HIGHEST PRESSURE AND VOLUME LASTS A LIFETIME**

LEIMAN'S NEW SAND BLAST
For Rapid Work in Large Quantities.
SEND FOR CATALOGS

LEIMAN BROS. Brill St., and Bonykamper Ave., Newark, N.J. 139-143 Centre Street, NEW YORK
Manufacturers of Jewelers', Silversmiths' and Metal Workers' Machinery, Tools and WORK BENCHES—Plants Equipped.

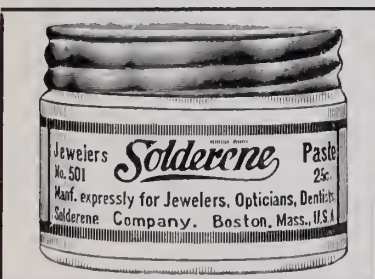

Solderene Paste No. 501
Manf. expressly for Jewelers, Opticians, Dentists.
Solderene Company, Boston, Mass., U.S.A.

A PURE SOLDER IN PUTTY FORM

Apply to place to be soldered using iron or flame. Requires no acids, rosin, pastes or other fluxes. Absolutely neutral, preventing rust and corrosion. Saves time and waste. Large sizes for the manufacturing trade. If your jobber does not carry it in stock send us his name and 25 cents and we will send you No. 501 Jar, prepaid.

SOLDERENE COMPANY (Dept. 0)
91 Oliver Street, Boston, Mass., U. S. A.

Importer and Manufacturer of WATCH MATERIALS, TOOLS, JEWELERS' SUPPLIES AND OPTICAL GOODS



Bargains in Staking Tools

Prices on Application

Fine Gold, Silver and Platinum always on hand. Highest Prices paid for Old Gold and Silver.

A. ZAREMBOWITZ
250 East Houston Street NEW YORK

PLATINUM AMERICAN PLATINUM WORKS
NEW YORK OFFICE 41 Cortlandt Street
NEWARK, N. J.



WORKSHOP NOTES AND QUERIES

Answers are also solicited from our readers to the questions published on this page.

QUESTION No. 2074.—Drilling Holes in Onyx.—*I have some pieces of onyx through which I want to drill holes. Some of the pieces are thin and frail. Is there any danger of breaking them?* D. H.

ANSWER:—For drilling holes through onyx make a drill out of steel wire, about the size of the hole wanted, and grind on the cutting edges; then with a file edge put in three or four straight lines; finally harden the drill by tempering. For drilling thin pieces of onyx it is best first to set in plaster to prevent breaking. The drilling is started and the drill head is tapped lightly with a small hammer, and then given half a turn. The drilling can be done dry and will work very well if the drill and cutting edges are in proper shape.

QUESTION No. 2075.—To Brighten Nickel Watch Cases.—*I handle many nickel and nickel-plated watch cases which need cleaning and brightening up. How can I best do this?* T. B.

ANSWER:—Nickel or nickel plated watch cases may be freshened up as follows: Dip into a cyanide of potassium solution, then rinse off in cold water and scratch brush on the lathe with a fine brass wire. To produce a polish the lathe must be used with cotton flannel or muslin buffs. Polish with Vienna lime or rouge. If there be deep scratches on the case they must first be buffed out on a felt buff and tripoli; then polished up with the Vienna lime, as stated above.

QUESTION No. 2076.—To Blacken Ivory, Horn and Bone.—*How can I blacken ivory, horn and bone?* T. B.

ANSWER:—A fine deep black can be obtained on ivory, horn or bone by boiling the material for some time in a strained decoction of logwood, and then steeping it in a solution of red sulphate of iron. Or paint over with a neutral solution of nitrate of silver.

QUESTION No. 2077.—Bracelets That Irritate.—*Some hollow bracelets irritate the wrist when worn. What can I do to remedy this?* B. T.

ANSWER:—The bracelets probably contain some of the pickling solution, part of which, when dry, will drop out in very fine powder and thus make the wrists sore. If there is any sign of irritation, the bracelet should be placed in water to which has been added a little washing soda, for five or more minutes; then rinse in running water and dry by dipping into boiling water. This operation should kill all chemicals.

QUESTION No. 2078.—Soldering Platinum.—*What kind of solder is used for platinum? I have tried hard solder, but*

have difficulty in making it run. S. P.

ANSWER:—For soldering platinum first sweat on both parts pure gold, then solder with hard solder. A better way is to unite the platinum by melting together without solder, but this requires much skill.

A Simple Method of Depositing Metal Upon Glass, Wood or Other Non-Metallic Substances.

FOR many purposes the usual method of depositing silver or other metals upon glass by painting a flux upon the surface, firing, and then plating is either unnecessary or impossible, says the *Brass World*. Its cost, too, is high and special apparatus is needed. It is possible, by means of apparatus which any electroplater possesses, to deposit any metal upon the surface of glass or other vitreous material, or upon wood, plaster or any other non-metallic substance. The process is simple and readily carried out.

PRINCIPLE OF THE METHOD.

The principle of the process is as follows: The glass or other material that is to be plated is first coated with a uniform covering of a slow drying varnish. When the varnish becomes "tacky" copper-bronze powder is brushed over the surface and the whole allowed to dry hard. The object thus treated is next immersed in a cyanide silver solution containing considerable silver and either no free cyanide or very little (an ordinary silver plating solution will answer). A thin film of silver is thus deposited upon the surface. After rinsing the deposition of the desired metal, copper, nickel, silver or gold may be carried out. The varnish, if of good quality, adheres tenaciously to the surface and if well done, washing with warm water will not affect it. The silver-strike may be omitted, but the deposition then takes place slowly. The coating of silver, however, allows the deposition to go with nearly the ease that it does upon solid metal. The surface covers over almost immediately and the metal deposits with great regularity.

THE FIRST OPERATION.

The first operation consists in cleaning the surface of the article from grease and dirt so that the varnish will adhere in a firm manner. Wood, or similar porous material, must first be treated with several coats of thin shellac varnish or heavy lacquer in order to render them waterproof. Unless this is done, the plating solution will penetrate the surface and prevent a good deposit from taking place. With glass, porcelain or other vitreous sub-

stances, or with any other impervious material that is unnecessary.

The varnish that is used for this purpose should be of the best quality. One of a slow drying nature is to be preferred as it is less apt to crack after drying, and seems to adhere more tenaciously. While no particular varnish is recommended, good results have been obtained with the varieties known as "Japalac" and "Crockett's Spar Composition." Both of these varnishes are slow drying and water does not affect them. There are many other grades, however, which will answer equally as well and the operator can use his own judgment in the matter.

The varnish should be left as it occurs in the can and should not be thinned. It is more difficult to obtain an even coating with thinned varnish than it is with that which is fairly thick. In cold weather the chill should be taken off from it by a slight warming. The object itself should not be too cold as it is then difficult to produce an even coating.

As all depends upon the production of a perfectly even coating of varnish, without specks, waves, bubbles, or streaks, much care is needed in doing the work. Any imperfections on the surface are reproduced in a larger scale when the metal is deposited. It is not difficult, however, with a good brush and the right quality of varnish, to obtain a perfectly even coating.

The brush that is used for the varnishing is a matter of considerable importance. If too soft, the varnish will not spread evenly, and if too hard, streaks will follow. A camel's-hair brush is really too soft for the purpose while an ordinary bristle brush, such as used for ordinary painting is too stiff. A brush of goats' hair, fitch hair, or similar material answers well.

In varnishing the surface of an object, it is sometimes difficult, if the color of the varnish and object are nearly the same, to distinguish the varnish so that every part may be evenly covered. In this case it is well to color the varnish by adding a small quantity of asphalt varnish or other dark colored material, or to use a colored varnish. No pigment, however, should be used for coloring but some soluble dye. Pigments leave an undesirable rough surface. For dark colored surfaces the ordinary varnish will answer.

In varnishing the article, care must be taken to spread evenly and in a manner that will prevent the formation of air bubbles. The object is to obtain a perfectly even coat without any imperfections in it at all.

The holding of the object is one of the difficult problems of this class of work, and the operator will have to exercise much judgment in carrying out this part of the process. Wherever possible, the wire should be placed in a part that can afterwards be cleansed from metal or where the marks left by the wire will not show. The matter is different from that of stringing metal work. In case the connection cannot be made except upon a place that will show, copper wire is twisted around the part in a firm manner and the varnish applied in the usual way.

After a good thickness of metal has been obtained, the wire is removed and a con-

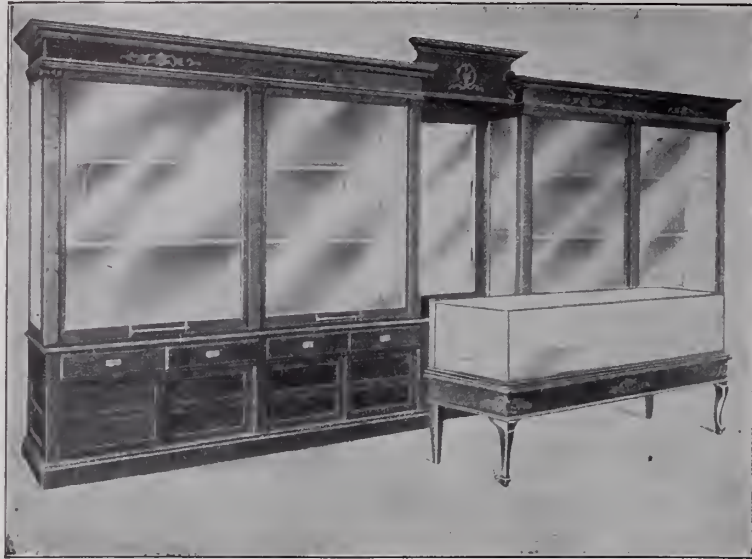

Colonial Wall Case, No. 123. Counter Case and Table, No. 107B.

F. C. JORGESON & CO.
 11 to 17 NORTH ANN STREET, CHICAGO
MAKERS OF High-Grade Jewelers' Fixtures

Do You Know Why

Gravers sharpened with the

"UNIVERSAL"

leave a bright, smooth cut?

Hight Mfg. Co.

Sole Manufacturers

Decatur, Ill.

For Sale by

A. C. BECKEN CO., Chicago, Ill.
 SWARTCHILD & CO., Chicago, Ill.
 E. & J. SWIGART CO., Cincinnati, O.
 F. J. BOESSE & CO., New York
 NORDMAN BROS. CO., San Francisco, Cal.
 LEONARD KROWER, New Orleans, La.



Price, \$2.00

BUY

CUTTLE FISH BONE

The mark P-E-A-CO. insures quality. Secure our prices before buying elsewhere; it will pay you.

P. E. ANDERSON & COMPANY
IMPORTERS 7 @ 13 GOLD ST., NEW YORK CITY

ARTHUR MARSON
 INC.

MAKERS OF
 Swivels, Spring Rings, Snaps and Specialties in the Line, in GOLD and PLATINUM
 Manufacturers of the **SMALLEST SPRING RING** on the market for Neck Chains
 SEND FOR SAMPLES
 23 MARSHALL ST., NEWARK, N.J.

ESTABLISHED 1886

GEO. M. BAKER

TELEPHONE UNION 1493-R

Gold and Silver Refiner and Sweep Smelter

Office, 91 Page St. }
 Works, 77-85 Page St. } **PROVIDENCE, R. I.**

Our processes are strictly up to date and facilities most complete for doing all kinds of refining.
 Specialties: Prompt and good returns.

CASTINGS Gold, Silver, Bronze, Brass German Silver, Copper and Iron

L.D. TEL. 2072 L. Supply Jewelers, Silversmiths Die-makers, Mould-makers, etc. Bronze Forces, Hard Bronze and Iron Shells for Die-cutting Machines Cast Iron Hub for sinking in Steel Dies. Chandeliers Undercut Work, Statuary.

AUGUST GRIFFOUL 313 HALSEY STREET NEWARK, N.J.

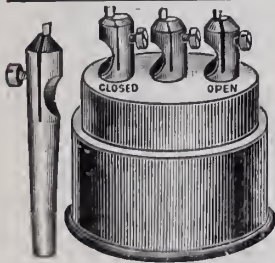

Set of **3 Jewel Setting Cutters**
 Price, \$3.00

This set will drill 100 and more sizes of holes.
 Send for Circular

Culman Tools

Are practical—ask the man who owns them if he wants to do without them at any price.

C. CULMAN

Maplewood - - - St. Louis Co., Mo.

Balance Chuck
 Price, \$3.50



Every Chuck or Cutter which becomes worn or broken will be replaced for 25 Cents.

WM. BOLLES' SELF-FILLING NON-LEAKABLE FOUNTAIN PENS



SIMPLE—CLEAN—PRACTICAL

We make our own goods—and they have stood five years' test by the largest dealers in the country. Write for Catalogue and Price Lists.
THE WM. BOLLES CO., 1108 JEFFERSON ST., TOLEDO, OHIO

Workshop Notes Department.

nection made in another place. The spot left bare by the removal of the wire is then varnished and treated with copper-bronze powder a second time. It is almost impossible, however, to make a good job in this manner and should only be employed as a last resource. In the case of ware which cannot be wired, such as a dish or saucer, the best method is to hold in the bath upon a brass or copper plate. The bottom ridge will not be coated at first, but after a time the article may be turned over and an even coating obtained.

When an even coat of varnish has been obtained so that no waves or brush marks are observed, the article is allowed to remain in a dry, warm place free from dust until the surface becomes sticky, or, so to speak, when the varnish has half-dried. This may be readily detected by touching in unimportant portion with the finger. From two to four hours are usually required for this operation, depending upon the dryness of the atmosphere. Some dry more rapidly than others, but one which dries hard in an hour or two should be avoided as it does not adhere as well.

APPLYING THE COPPER-BRONZE POWDER.

When the varnish has become "sticky" or "tacky" it is ready for the copper-bronze powder. This powder is very finely divided copper and is made by pounding pure copper under a steam hammer until it becomes impalpable. It may be purchased from dealers in bronze powder and only that which is very fine should be bought. In the bronze powder trade, it is known as that which has no "grain." A coarse bronze powder does not give a smooth deposit and it frequently refuses to adhere properly.

The copper-bronze powder is brushed over the surface of the sticky varnish with a soft brush. If possible, it is advisable to carry on this operation under an exhaust hood as the fine particles of copper are very irritating to the throat or nostrils. If only one or two pieces are to be done at a time, the hood is unnecessary; but for constant use, it must be employed or the operator will suffer.

The bronze powder must be thoroughly brushed into the surface. It will not suffice merely to coat it. Dip the brush into the powder so that a large quantity will adhere, and then brush the surface so that the whole becomes rubbed in. Repeat this over the whole surface. Then brush off the superfluous powder with a large, soft brush. The object is now allowed to dry. Care must be exercised not to touch the surface either before or after the powder has been applied or marks will result.

The drying usually requires about twenty-four hours in order to obtain a good, hard surface. When this time has elapsed, brush off the loose particles of bronze powder from the surface so that they will not become loose in the solution. This is important. Loose particles which float, settle upon the article and lumps finally are formed.

THE STRIKING OPERATION.

The object of the "strike" is to coat the surface with a thin pellicle of silver and

also to remove the film of oil that is present upon the bronze powder. The striking bath may be any silver plating solution containing very little free cyanide and considerable silver. The silver plating solution used for plating flat ware answers well. The object of keeping the free cyanide down in this bath is to avoid the dissolving action upon the copper. A silver solution without any free cyanide is also good, but the ordinary silver plating solution used for flat-ware, containing from three to four ounces of silver and about the same quantity of free cyanide to the gallon, gives good results.

The object coated with the copper-bronze powder is immersed in the silver solution for a few seconds (no current is used) and the surface will immediately become covered with silver. The copper precipitates the silver from the solution and is dissolved by the cyanide. This operation serves the two-fold purpose of giving a coating of silver of greater compactness than that of the copper, and also of removing the thin film of grease that the powder contains. (Bronze powder is made by pounding bronze to a powder under steam hammers. A little oil is added to prevent flying and adhesion of the particles.)

When the surface is completely whitened, the object is rinsed and is ready for plating. This plating may be carried out either in a copper, nickel, or silver solution, but for the majority of purposes the acid copper solution is the best. The article is simply immersed in it and plating carried on as usual.

THE PLATING.

The deposition may be commenced with about 3 volts until the surface becomes well covered, when it should be dropped to about 1 or 1½ volts in order to avoid burning. The acid copper solution should not contain over two or three per cent. of free sulphuric acid and some material must be added to give a smooth deposit. Dextrin is useful and is extensively used for this purpose. Molasses is also used. The addition of about half an ounce of either of these substances to a gallon of copper solution will give the required results, although more or even less will answer. The proportion need not be exact. The deposit produced under such conditions is smooth and free from the wart-like appearance formed when nothing is used in the solution.

After a deposit of about two hours has been given the article, it is removed and the surface scratch-brushed in order to matt down any roughness. This scratch-brushing may be repeated from time to time if very heavy deposits are to be produced.

When a perfectly smooth surface is desired, the deposit is allowed to go for some time, say four or five hours, and then the whole is cut down with a sand buff in the usual manner until all roughness has been eradicated. The article is then returned to the bath and further deposition continued.

As heavy a deposit as desired may thus be obtained and in a smooth condition.

Silver, gold, or other metals may be deposited over the copper if desired. As the acid copper solution is suited for the

production of heavy deposits, it is recommended wherever it is possible to use it; but if desired, nickel, silver or gold solutions may be substituted for it. The deposition, of course, is then much slower.

Some excellent results may be obtained by the use of this method and in many instances it may be substituted for silver-deposit work. The ease with which it may be accomplished renders it quite attractive and there are undoubtedly many instances in which it will prove valuable.

This grade of paper, of course, is not actually bleached upon the grass, as linen or other textile goods are frequently done, but it is only a trade name for the paper that is used for wrapping metal goods. It may have been bleached once upon the grass, but history fails to record it if so. Its value lies in the fact that all chemicals used in its manufacture and in bleaching it have been carefully washed out and nothing but a practically pure cellulose remains.

Smyrna Umbrella Imports.

WRITING from Smyrna, Consul Ernest L. Harris says that up to within recent years the umbrella and parasol trade of that Turkish region was supplied entirely by France, Austria, Italy and England. He furnishes the following trade particulars:

"The article ranged in price from \$2 to \$5.50, and the annual importations amounted to about \$8,000. Some 20 years ago, the manufacture of cheap umbrellas was started in Constantinople and Saloniki, and owing to the inferior quality of materials used, as also to the cheapness of native labor, the home-made article was soon able to compete advantageously with foreign goods. Smyrna also soon followed the example of the capital and her rival city, and can now boast of several good umbrella factories.

"With the exception of the plain wooden sticks, which are made locally, all the materials entering into the makeup of an umbrella are imported from Europe. Ninety per cent. of the complete steel frames and of the disconnected ribs for mounting on wooden sticks come from Rhenish provinces, especially from the city of Weyer. The balance is furnished by Italy, England and Belgium. France also supplies the fine, nickeled article, the consumption of which, however, is very limited. Formerly France exported to these parts horn handles for about \$2 a dozen, but a firm near Vienna delivers handles for little over \$1 a dozen.

"For the cheap, current article, which constitutes the greater part of the demand, ordinary cotton cloth, known under the name of 'Regina' used to be imported from Manchester. Of late years, however, Italy has secured nearly the whole of this trade by under selling English manufacturers. The better grades of cotton cloth are imported from England, Austria, Germany and Italy. The half-silk and half-cotton cloth comes from Austria and Germany. Silk is supplied by Italy and Austria and very little by France. Austria furnishes about 90 per cent. of the sticks with handles.

"The umbrella trade of Smyrna amounts, on an average, to \$50,000 per annum, of which \$20,000 is supplied by Constantinople and Saloniki, and \$10,000 by Europe."

C. DORFLINGER & SONS

36 MURRAY STREET

NEW YORK



Hand-Made Blanks only.
Cut, engraved and etched
glass. Light, medium
and heavy stemware,
tumblers, etc.

LEATHER WATCH BRACELETS



Send for assortment on Display Card

ESTABLISHED
1850

C. F. RUMPP & SONS

TRADE MARK

Manufacturers of FANCY LEATHER WARE
PHILADELPHIA

New York Salesrooms, 683 and 685 Broadway

OWANDA CUT GLASS CO.

Manufacturers of

RICH
CUT
GLASS



Originators of
New Designs

Honesdale,
Pennsylvania

No. 1088. 3 Piece Compot

A Complete line of our high-grade goods
shown at our

New York Office, 68 West Broadway

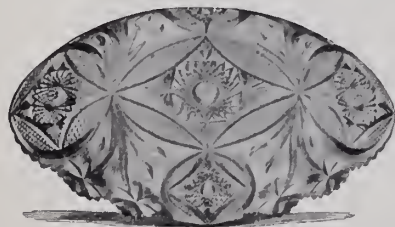

"Wild Rose," No. 122—14-inch
Ice Cream Tray

Irving Cut Glass Co. Inc.

Manufacturers of

Artistic Cut Glass

HONESDALE, PA.

F. W. REICHENBACHER

New York Representative 59 PARK PLACE

CROUCH & FITZGERALD



**Jewelry
Trunks
and Cases**

177 Broadway,
Bet. Cortlandt
and Dey Sts.

688 Broadway
723 6th Ave.,
New York.



S. BORGZINNER CO.

MANUFACTURERS and IMPORTERS

82 and 84 Nassau St.
NEW YORK



LEMAIRE OPERA GLASSES

LEMAIRE FIELD GLASSES

Best in the World. Used in the Army and Navy.

SUSSFELD, LORSCH & CO., Importers

37 MAIDEN LANE, NEW YORK

MARQUE DE FABRIQUE



All Genuine Glasses
Bear This Mark
Large Variety in All
the Latest Styles

THE CONNOISSEUR

Devoted to Art Pottery, China, Marbles, Bronzes, Cut and Decorated Glass Ware, Bric-à-Brac, Lamps, Art Metal Wares, Fancy Goods and Kindred Lines.

The White House China Collection.*

THE rare collection of china ware of Presidents of the United States, on exhibition in cases in the basement hallway of the White House, is slowly receiving valuable additions, and it is the hope of Mrs. Roosevelt, who has taken deep interest in this collection, that it will soon embrace some of the household ware of every presidential family the White House ever sheltered.

During the incumbency of President Harrison his wife became interested in the disappearance of historic household and other articles from the White House. She made a careful search through the attic of the building, which was then used as a storehouse, and discovered much in the way of furniture, bric-à-brac and other articles of historical association. She undertook the preservation of these. She was ambitious to save for posterity some of the specimens of china and plate then in the house. She made many selections and went so far as to design a cabinet which she hoped to have built in the walls of the state dining-room, where the ware was to be preserved and displayed. The impairment of her health prevented her carrying her plan into effect.

About two years ago Col. Thomas W. Symons, who was then superintendent of public buildings and grounds, brought to the attention of Mrs. Roosevelt the ideas which had been entertained by Mrs. Harrison. Mrs. Roosevelt at once became enthusiastically interested, and determined to put the project into execution. She sent for Mrs. Abby G. Baker, who had made a study of the White House china and plate, and asked Mrs. Baker to assist in putting into effect a plan for securing specimens used in each administration.

There was already on hand in the White House specimens of china used during the administrations of Presidents Lincoln, Grant, Hayes, Arthur, Harrison, Cleveland, McKinley and Roosevelt. Mrs. Roosevelt designed four cabinets to receive the china of these administrations. When this had been done she determined to procure, if possible, articles at one time owned by each and every one of the Presidents, and she asked Mrs. Baker to find and collect the ware, so that no change of administration would ever disturb or remove the collection from the White House. She placed it in the custody of the bureau of public buildings and grounds, the superintendent of which always has a general charge of the Executive Mansion.

Mrs. Baker at once began the effort of

securing some of the historic material which was of accepted value. There was no appropriation from Congress available for the ware, and it was known that, with few exceptions, the coveted articles were owned by people who did not care to part with them for a money consideration. While this was realized, it was felt that there were some public-spirited owners who would feel it a patriotic privilege to donate from their private, priceless collections some one or more pieces of the presidential ware to this most commendable public collection. It was further thought that others who would hesitate to make an outright donation would be willing to make a loan, and that there would be still others who would be willing to sell such relics and would place them in the cabinets with the expectation that eventually there would be an appropriation from which they could be purchased.

Nor has this expectation been disappointed. Soon after the cabinets were placed in the corridor a loyal daughter of the American Revolution, Mrs. James S. Bradley, of New York, wrote Mrs. Roosevelt offering to loan three pieces of Washington china, a cut glass decanter and berry dish, and a silver fish knife; also silver candelabra, with two branches, and a gravy boat which originally were the property of President and Mrs. Madison. The offer was gladly accepted, and the pieces were plainly labeled as a loan to the collection from Mrs. Bradley and placed in the cabinets, where, it is needless to add, they have been admired.

Within a little time after this J. Henley Smith, of Washington, whose mother's mother was Miss Dandridge, a sister of Martha Washington, and whose father was at one time Secretary of State under Madison, presented the collection with two plates belonging to a set of dinner plates which she used in the White House and which "Dolly" Madison presented to the senior Mr. Smith herself.

The next gift was from the wife of Brig.-Gen. George F. Elliott, commandant United States Marine Corps, and a direct descendant of Governor Bradford, of Massachusetts, as well as of three other colonial governors. This gift consisted of four pieces of Monroe china and belonged to a tea set presented to her father by a nephew of President Monroe.

Later there were secured three pieces of the Adams china. They were a plate from the state dinner set used by John Quincy Adams and two Staffordshire salt cellars also used by him. They were contributed to the collection by Mrs. Erskine Clement, of Newburyport, Mass. She is a great-granddaughter of John Adams, and the great-granddaughter of John Quincy

Adams. Her mother was born in the White House during the administration of the latter.

There also came into the possession of Mrs. Baker a platter which belonged to President Pierce. As its authenticity could not at first be accredited, a long investigation was made, so as to make sure of its historic value. There was also secured some of the china ware of President Jefferson, which has attracted as much attention as any other in the collection.

A short time ago Miss Mary Wilcox, of Washington, as a memorial to her mother, the late Mrs. Emily Donelson Wilcox, who was the first child born in the Executive Mansion, placed in the White House cabinet six pieces of china and glass formerly owned by President Jackson and used by him during his administration.

She has now added to these one of the historic candelabra presented to Gen. Jackson by Tammany Hall, of New York, and which are inscribed as follows: "Andrew Jackson, Our Federal Union. It must be preserved." The candelabrum is very handsome, and one of the most interesting pieces of the collection.

Through Mrs. Wilcox, Mrs. Baker learned that Mrs. George W. Fall, of Nashville, Tenn., and a niece of President Polk's wife, had in her possession some of the glass and china which were owned and used by President Polk during his administration. Correspondence was entered into with Mrs. Fall, and the result was that she has made a most generous gift of this ware.

It consists of an old-fashioned diamond-shaped fruit stand, white and gold, with curved sides and a pedestal that is quite tall for the size of the bowl; a colonial tea plate and cup and saucer of the old Dresden ware decorated with pink roses and shaded background of blue and pink, and trimmed with gold; a deep blue goblet, and a finger-bowl with the old-time mouthpiece—a small-sized tumbler-shaped glass which was filled with perfumed water and used for the mouth alone.

The pieces have been placed in the second cabinet on the south side of the corridor on the ground floor of the White House, and add inestimably to the historic interest as well as the beauty of the collection.

With the growth of the collection Mrs. Roosevelt has ordered two more cabinets, which will make six on display in the basement corridor. That all of these may be filled, Mrs. Baker is now on a hunt for china of the Tyler and Buchanan administrations, and is hopeful of securing some of that period through Tyler's sons, who live at Williamsburg, Va., and his daughter, Mrs. Ellis, who lives near Roanoke, Va.

*From the *Crockery and Glass Journal*.



**Buckles
Clasps
Belt Pins**

Artistic, But Inexpensive
PRODUCTS OF
The "Apollo Studios"

WILL INCREASE YOUR
SPRING SALES

Bernard Rice's Sons

544 BROADWAY

Works and Studios { 4-6 Marion St.
205-207 Lafayette St. NEW YORK



No. 471—ELECTROLIER

(Patent applied for)

Copper Bound, Leaded Glass Shade

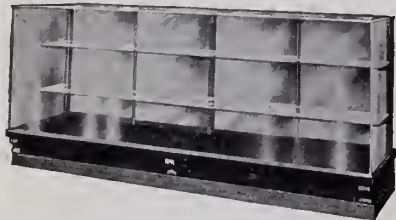

**What Do You Want
In Show Cases?**

Do quality, individuality, style and durability—at the right price interest you?

"Quick Sales" SHOW CASES

are leaders in these respects. Our catalog proves this and

gives you the choice of the greatest variety of good styles for indoor and outdoor use. Only one quality—the best. Let us know your needs and we will submit illustrations and prices. Write us to-day.

Detroit Show Case Co.

Dept. K

"Show Case Makers to Progressive Merchants"

476-490 West Fort Street

DETROIT, MICH.

STORE FRONTS The Petz Patent Store Front Construction saves space gives more room for display and costs but little. Our new book, "Metal Store Fronts," free on request.

The
St. James

Cor. Walnut and 13th Sts., Phila., Pa.

THE IDEAL HOTEL OF
THE QUAKER CITY

A spacious fire and burglar proof safe has been provided for the convenience of the trade. Palatial rooms with bath \$2.50 per day and up. Rooms without bath, (running water) \$2.00 and up.

EUGENE G. MILLER, Mgr.

PATENTS

obtained on inventions and designs. Trade marks, prints and labels registered.

R. W. BISHOP,

ATTORNEY-AT-LAW,

908 G Street N.W., Washington, D.C.

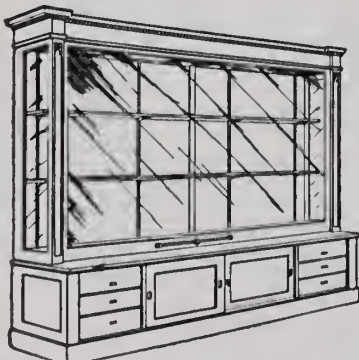

Jewelry Store Fixtures and Show Cases

OUR SPECIALTY

The enlargement of our factory in our new location enables us to quote low prices.

If you need fixtures or show cases let us hear from you. Estimates cheerfully furnished.

ALEXANDER H. REVELL & COMPANY, Rees, Dayton, Eastman and Hawthorne Sts., **CHICAGO, ILL.**

A Candid Confession from a Retired "Near-Diamond" Merchant

(From the Washington, D. C., Post.)

It was experience night at the clubhouse of the Retired Millionaires' Association. The dry goods man, the butcher, the plumber, and even the dentist had told with what ease and grace they had accumulated sufficiently to lean back and take it easy, but there was nothing remarkable or specially speedy about the manner in which the club members' fortunes were made until the retired imitation diamond merchant pushed his chair into the center of the circle and proceeded.

"I have always thought that the mirrors and the electric lights had more to do with than anything else," said the retired dealer in imitation gems, "but I know you will agree with me when you have heard my story that my business methods are certainly entitled to some of the credit.

"I was very proud of the arrangement of my show window, for with those mirrors and lights beating upon the display of near-diamond rings and pins the gems in Timothy's window had only a single candle over brilliancy compared to mine. I can best illustrate my incomparable business methods by having you follow an interested person from the rural districts who has stood in front of that window for 15 minutes and has at last decided that he can't go home without that ring marked \$5."

"The stones in these rings are made up in Providence, by the way, and cost me a little over \$3 a dozen. The cost of the brass ring itself isn't worth mentioning here.

"The delegate from the rural districts tells me that he will take the \$5 ring if the diamond in it is genuine, and if the ring itself is solid gold.

"The stone in that ring is genuine, all right," I tell him. "That's a scientific stone. You see, it's made from the debris and refuse of real diamonds. You could hardly expect to get a real diamond for that money. But this stone is made of exactly the same material as the stones the millionaires wear. It's made under intense heat and by hydraulic pressure, and I know from experience that if you go to the best jeweler in your town. I don't care where you live, he can't tell the difference. It keeps its luster forever."

"Do you give a guarantee with this diamond?" the inquirer is likely to ask.

"I tell him certainly we give a guarantee. We guarantee it forever. We give you a written guarantee as good as the notes of a national bank."

"Do you guarantee the ring to be solid gold?" he asks next.

"I tell him it's solid gold, adding in an undertone which he can't hear that it's a solid gold shell.

"Well, if you'll give me a written guarantee I'll take the ring."

"Then I hand him one of our ordinary sales checks, which merely shows that he has bought a ring for \$5. The purchaser is inclined to be dissatisfied with the guarantee, but I tell him that's the way we

make out our guarantees. He looks a little dubious and then starts to walk out.

"Oh, just a moment, brother," I call after him. Everyone who comes into my store is brother to myself and my clerks. "Pardon me, before you go I would like to show you a much finer ring—one that is superior in every way to the one you have just bought."

"Then I pick a ring that is identical with the one he has bought. I make a swift movement with my right hand and run the stone through my hair. The friction of the hair makes the stone fairly glow.

"Now, that ring you have bought is a machine-cut stone," I say. "I mean that after the stone was manufactured with heat and hydraulic pressure it was cut by machinery. This one which I am now showing you was cut by hand."

"I have the lights in the doorway arranged so that they concentrate on a certain spot. I stand under the spot and move the ring between my thumb and forefinger.

"This ring," I go on, "you must understand, is made from the first clippings of genuine diamonds. It only costs \$5 more than the other ring, and if you really want a superb thing I would advise you to take this. You will notice that the ring is set in duplex prongs, with each prong delicately tempered. Moreover, the ring itself is solid gold, made of two gold plates rolled together."

"But I thought you said the ring I have is solid gold?" the customer says, somewhat alarmed.

"Oh, no.; you misunderstood me," I reply. "I told you that your ring is a solid gold shell."

"Then the customer starts an argument on what I did say, and I switch him off by telling him beneath the two plates of gold in the ring I am about to sell him is gold alloy, which will make the ring wear better than the best gold watch he ever saw.

"Understand, brother," I say, "we don't carry any plated goods here. Everything is either solid gold or solid gold shell. You can't duplicate the gold alone in that ring for the price I am selling it to you. I want to treat you right, but you don't seem to appreciate what I am doing for you."

"Invariably the customer becomes a bit peevish at this point, and shows a disposition to want to have the \$10 ring appraised in a jewelry store or pawnshop before he parts with his money. I begin to resent his imputations at about this time, and am likely to say:

"I want you to understand that we don't allow anyone to appraise our rings. Our word has been good enough for thousands of customers as good as you are, and if it doesn't suit you leave the ring behind."

"Here is where I play my trump card. The time has now arrived to make the customer feel cheaper even than the ring

he has bought, after which he will be in a mood to listen to my greatest offer.

"I hate to think that you are a cheap man," I say, "but I'll tell you what I honestly believe. I don't think you've got the nerve to take up the greatest offer I've ever made."

"Then I tell one of my clerks to hand me the ring that was made expressly for Mr. Willard, the well-known horse owner. We keep a lot of rings of a little different appearance, but of exactly the same quality, wrapped up in boxes in the safe, with names on them to correspond with the size of the purchaser's hand. I have already discovered that the Willard ring is the one that will fit this customer.

"This ring that Mr. Willard ordered is made of 60 per cent. carbon and 40 per cent. diamond clippings," I say. "You'll notice, brother, that the carbon in it gives it a greater luster than the most expensive diamond you ever saw. Mr. Willard had agreed to pay \$50 for this ring, and left \$25 on deposit. Shortly afterward he lost all his money at the race track, and I've got the ring on my hands. I wouldn't like to part with this ring for \$25, but just to see whether you've got any nerve, which I very much doubt, I'll sell it for \$25."

"Nine times out of 10 the customer takes this ring, if for no other reason than to show that he can't be bluffed. Sooner or later he finds out that a whole quart of such things can be bought for \$25, and he comes back with the express purpose of getting his money back. I can see at a glance whether he is sincere in his determination to get his \$25. Sometimes I can induce him to depart with a pair of gold cuff buttons, and consider himself fortunate. In other cases it is necessary to accuse him of being a diamond thief, and of having stolen a ring when he was in before. I make such a strong pretense of calling in the police that he usually is glad to depart without giving further trouble.

"My profits have averaged \$40,000 a month, and during December have run as high as \$75,000. I think my hearers will all agree that my fortune has been made tolerably easy."

The hearers did so agree and passed resolutions thanking the retired imitation diamond merchant for the extreme candor with which he disclosed the secrets of his trade.

A South African diamond mine or "pipe" is the crater of an extinct volcano, and the diamondiferous ground forms the filling of that crater. It is generally conceded by geologists that the diamond ground has been forced up from unknown depths in the form of liquid mud; that is to say, it was a volcano that threw out boiling mud instead of molten igneous rock. In some respects, therefore, it would more closely resemble a geyser than a volcano. Where the diamond ground is found within 50 or 100 feet of the surface it is greenish yellow in color, crumbles to the touch, and is known as "yellow ground." At depths below atmospheric influences it changes to a greenish blue color, becomes much harder and is known as "blue ground" or merely "blue."—*Mines and Minerals.*

LEES & SANDERS,

**DON'T BE AFRAID OF THE FREIGHT
IT WILL PAY YOU TO SEND**

SWEEP SMELTERS, BIRMINGHAM, ENG.



Enough metal is often lost in the careless reduction of
Filings, Waste, Scraps and Sweeps

to cover the cost of the work. We are careful and considerate enough to overcome this loss, thus enabling you to meet the expense out of a surplus that is ordinarily lost.

Try us and see if it isn't so

No. 236 Eddy St., **CONLEY & STRAIGHT,** Providence, R. I.

Gold and Silver Refiners, Assayers and Sweep Smelters, Dealers in Fine Gold, Silver and Platinum, all kinds of Gold and Silver Anodes.

'Phone 3759-R.

WM. F. RENZIEHAUSEN CO.

43-47 Oliver Street, NEWARK, N. J.

Gold and Silver Refiners

PROMPT RETURNS MADE FOR ANY MATERIAL CONTAINING PRECIOUS METALS
DEALERS IN GOLD AND SILVER, AND ROLLERS OF STERLING SILVER

Gold and Silver Anodes a Specialty



WE BUY

Old Gold and Silver Filings, Polishings, Sweeps, Hand Washings, etc. We will make accurate valuations and hold consignment subject to your acceptance. If valuation is not satisfactory, we reship to you at our expense.

WE PAY FOR OLD GOLD:

22 K. 88c. per dwt.	12 K. 48c. per dwt.
20 K. 80c. " "	10 K. 40c. " "
18 K. 72c. " "	8 K. 32c. " "
16 K. 64c. " "	6 K. 24c. " "
14 K. 56c. " "	4 K. 16c. " "

MARKET RATES FOR SILVER AND PLATINUM

Try us and you will Appreciate our Squireness, Promptness and Accuracy.

T. B. HAGSTOZ, Ltd., Main Office, 709 Sansom St., Philadelphia, Pa.
SMELTERS, ASSAYERS, REFINERS.

WE SELL

Gold, Silver and Platinum, various qualities, rolled flat or drawn to wire of any gage.

PRICES OF ALLOYED GOLD:

8 K. 42c. per dwt.	14 K. 66c. per dwt.
10 K. 50c. " "	16 K. 74c. " "
12 K. 58c. " "	18 K. 82c. " "

Gold and Silver Solder, either from formulas furnished, or our own. "T. B. H." Alloy, 25c. per oz. Guinea Gold, 75c. per lb. Shot Copper, 40c. per lb. We will send tables for alloying without charge. They save figuring.

The Ackley Engraving Block AND "JOKER" ATTACHMENT



Pat. March 20, 1906

Made by Engravers who saw the need of a Handy Time Saving Block

THE BEST IS THE CHEAPEST

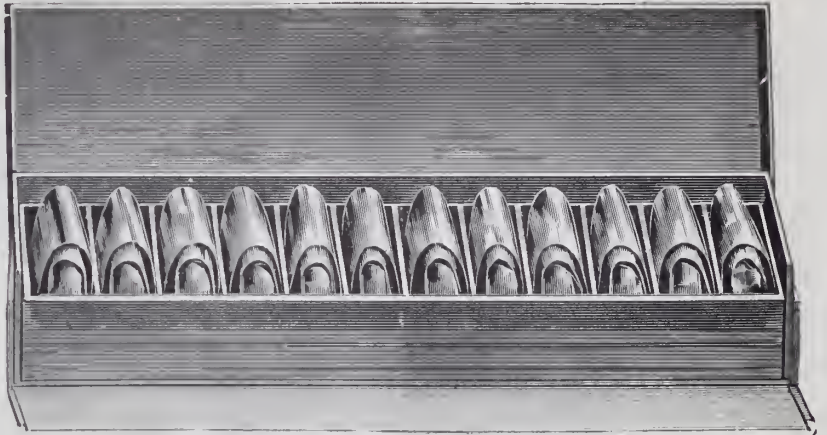

Why the "LAFAYETTE MAINSPRING" is superior

1st—It is guaranteed to be made of the Best Steel. 2d—It is made by Skilled Hand Labor. 3d—Each Spring is wrapped in Oil Paper and Silver Foil, which packing positively avoids exposure to the moisture of the air, and therefore all danger of rust is prevented. 4th—Each Spring bears a metal Tag, indicating the watch it is intended for, which accuracy is warranted. 5th—Each dozen is put up in a neat Box, having twelve partitions, one for each spring, so the handling of several springs at one time is avoided. 6th—The finish of the "Lafayette Spring" is, like its quality, superior to any in the market.

THE ACKLEY ENGRAVING BLOCK: Always ready to hold any article. No hunting for pins. The patent friction pins all remain in the head. Simply pull up to the desired height the ones needed. Each pin is numbered on top to designate size of groove or notch in it. They are so arranged in the head that they will readily hold all large or small articles either by three or more points of contact. The swivel jaw can be locked rigidly in an instant. The key will not fall off, yet it may be removed instantly. The patent base eliminates all unnecessary weight and gives the same movement as the old ball and socket base. This block is the result of years of practical experience of engravers who know the wants of engravers. There is nothing complicated about it to wear out or get out of order. Workmanship and materials are the best. Each part is copper plated before being heavily nickel plated, thus insuring a fine durable finish. Height, 6 $\frac{3}{8}$ inches. Diameter of head, 2 $\frac{5}{8}$ inches. Diameter of base, 6 inches. Weight, 8 pounds. THE "JOKER" ATTACHMENT, as shown beside the block, holds large and small signet and band rings, cuff buttons, collar buttons, signet pins, etc., firmly, without marring. It may be used on any block.

HENRY ZIMMERN & CO., Inc., 77 John Street
New York City
Exclusive Wholesale Distributors for U. S. and Canada

THE
FORMAN CO.
SIX LIBERTY PLACE
OPPOSITE 23 MAIDEN LANE
NEW YORK N. Y.

SIGNS
RAISED METAL LETTERS
SAWED OR CAST
BRASS
ENGRAVED OR ETCHED
WOOD
CARVED OR PLAIN
IRON
WROUGHT OR ENAMELLED
GLASS
PLAIN OR ETCHED

SEND FOR
BOOKLET

Frank Dederick.

Established 58 Years.

James E. Dederick

James H. Dederick's Sons, Assayers and Bullion Dealers.

All qualities of Gold and Silver, in Plate, Square and Round Wire, Rolled to any gauge. We are selling fine gold for \$1.04 per dwt. which we guarantee to be government assay bars. Small rolling for the trade.

ALL QUALITIES OF GOLD AND SILVER SOLDER.

16 Maiden Lane

NEW YORK.

We buy Old Gold and Silver.

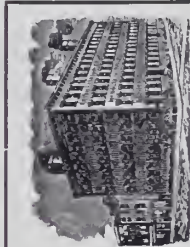

L. LELONG & BRO.

Gold and Silver Refiners, Assayers and Sweep Smelters

S. W. Cor. Halsey and Marshall Sts., NEWARK, N. J.

Prompt attention given to Gold and Silver Bullion.

SMELTING FOR THE TRADE.

UNITED STATES SMELTING AND REFINING WORKS

L. & M. WOLLSTEIN

16 JOHN STREET, NEW YORK

SWEEP SMELTERS AND ASSAYERS

Dealers in Gold and Silver Assay Office Bars. HIGHEST and MOST PROMPT RETURNS made for Sweeps and all kinds of Waste containing precious Metals.

HIGHEST PRICES PAID FOR OLD GOLD AND SILVER

Manufacturers of STERLING SILVER.

Importers of PLATINUM.

Ore and Bullion Assays a Specialty.

A Few Words About Mainsprings

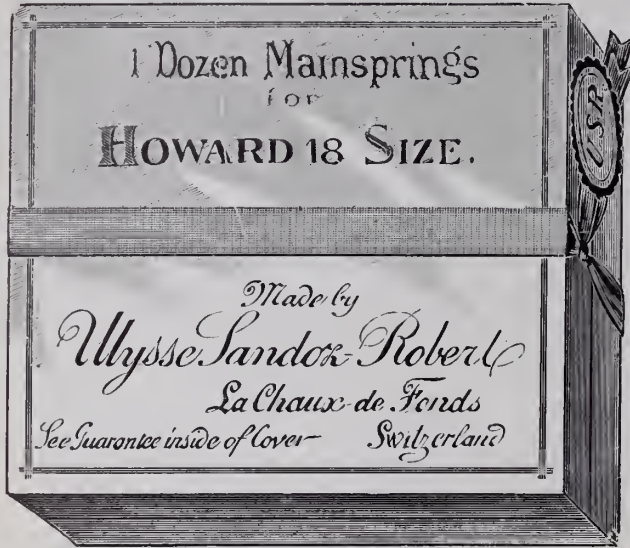

There is no article of material used by the watchmaker or the watch repairer about which, if he be a careful and thorough workman, he feels more solicitous than the *Mainspring*. Next to the fragile watch glass, the mainspring is more frequently replaced than any other article used in watch repairing. While the percentage of breakage is high in all watch springs, it jumps into appalling proportions when they are of an inferior quality, unless their temper is so low as to make them almost useless, and certainly of little value in watches that are to serve the purpose of timekeepers. When we offer you the *Ulysse Sandoz Robert* spring, we feel confident that you are getting the best that skillful hands and lifelong experience can produce.

Made for all American Watches. Per dozen, \$1.25

The Ely Watch Protector

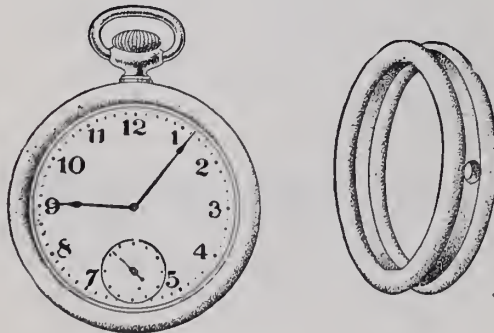

Designed to give the maximum "cling" on the lining of the pocket, with the least possible bulk. Scientifically correct. Made from soft yielding rubber, treated by secret process to prevent it from tarnishing gold or filled cases. No hooks, fastenings or other annoyances. Fits the rim under tension, sealing the joints of the case. Excludes dirt and moisture. Foils pickpockets. Saves hard knocks. The best preventative against dropping watch out of pocket when worn with a fob chain.

Made for 18, 16, 12 and 6 size open face watches.

Price per dozen, \$2.00

Spectacle and Eyeglass Strap Plier No. 105

Price, each, \$1.25

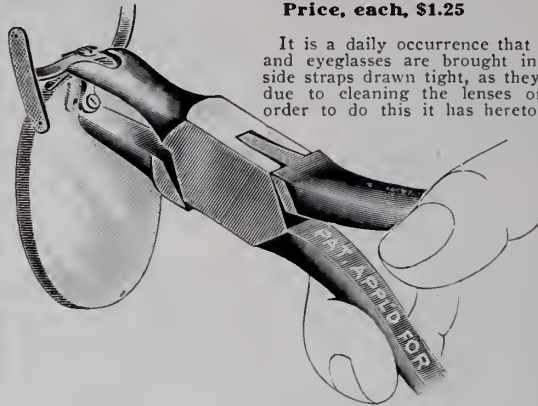

It is a daily occurrence that frameless spectacles and eyeglasses are brought in to have the small side straps drawn tight, as they have become loose, due to cleaning the lenses or other causes. In order to do this it has heretofore been necessary to remove the lenses from the mountings, and as all know, this very often results in breaking or chipping the lenses.

By the means of this plier this can be avoided and the work quickly done.

All that is required is to loosen the screw two or three turns, clamp the frame as shown in the illustration, and bend the straps to the lenses. Retighten the screw, and the work is done.

DO NOT NEGLECT to loosen the screw, as otherwise a good job cannot be done, and the lenses are likely to be broken.

Made of best quality Swedish steel, nickel-plated.



Barrel Cover Plier No. 54

The jaws of this Plier are provided with two circular disks of German silver; both of which are slotted or cut out to admit the longest barrel arbor made. The risk of bruising or scratching the barrel cover is eliminated by the use of this plier. The jaws being parallel, the pressure on the cover is even and full control over the work is possible.

Price, each, \$1.25

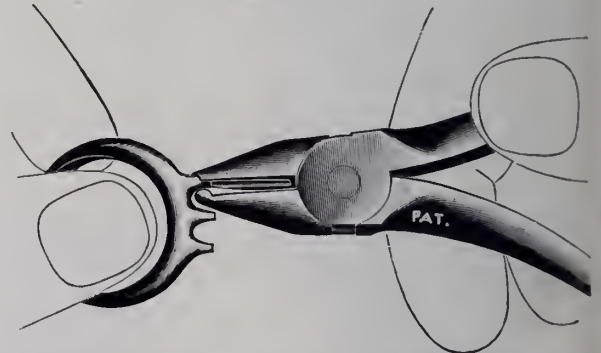

Claw Stretching and Repairing Plier No. 95

This Plier should find ready favor with all jewelers, considering only the saving of time when repairing a broken or worn setting.

Made of best Swedish steel finely nickel-plated. Each, \$1.25

DIRECTIONS:

For repairing worn settings, place slotted jaw on the outer side of the setting and the ball tipped one on the inner side, pulling from or pushing against the setting, as occasion may require, all the while pressing the handles of the plier firmly together.

With little practice, any jeweler can easily repair a worn-out Tiffany or skeleton setting, or draw out a broken claw as good as new, in less than five minutes.

Unequaled for shaping ordinary settings for Moonballs, Whole Pearls, or any round stone.

FOR SALE BY ALL JOBBERS IN THE UNITED STATES AND CANADA

HAMMEL, RIGLANDER & CO. 47-49 Malden Lane
New York

THE JEWELERS' CIRCULAR

WITH WHICH ARE CONSOLIDATED

THE HOROLOGICAL REVIEW,
THE JEWELERS' WEEKLY,
THE JEWELERS REVIEW

Copyright 1908 by
The Jewelers' Circular
Publishing Company.

11 John St., Corner Broadway, New York.

Entered as second-class matter at the New York, N. Y., Post Office.

40th Year.

WEDNESDAY, FEBRUARY 26, 1908.

Vol. LVI. No. 4.



Artistic Offertory Basin Made for Trinity Cathedral, Cleveland, O.

(See Text on Page 35.)

ALVIN SILVER

"ORANGE BLOSSOM"



ALVIN

MFG.

CO.



Sugar Shell

Sterling
Silver

The true test of a design in table silver is the effect produced when the table is arranged for formal hospitality.

Pieces of the Orange Blossom design, shown above, make a most attractive group.

This design is made in over one hundred different articles, and is especially suited to wedding gifts.

It is made in sterling silver, stamped with the above trade-mark, and can be obtained from any jeweler, in sets or single pieces, to meet the requirements of complete service.

"BRIDAL ROSE"



ALVIN

MFG.

CO.



Sugar Shell

Sterling
Silver

The true test of a design in table silver is the effect produced when the table is arranged for formal hospitality.

Pieces of the Bridal Rose design, shown above, make a most attractive group.

This design is made in over one hundred different articles, and is especially suited to wedding gifts.

It is made in sterling silver, stamped with the above trade-mark, and can be obtained from any jeweler, in sets or single pieces, to meet the requirements of complete service.

The two most appropriate patterns of Sterling Silver Flat Ware for wedding anniversaries. These patterns are being advertised in the leading magazines to stimulate trade, and so help the retail jewelers.

These magazines will be read in millions of homes all over the United States.

Be prepared to meet the demand. Complete your stock with fancy pieces and cutlery.

ALVIN MFG. CO., Silversmiths, NEW YORK

Fahys

Quality,
Skill,
Experience,
and
Enterprise

have been employed to place Fahys Cases where they are to-day—that is, as leaders. There are three grades of Gold Filled Cases necessary for the jeweler to supply all demands for high grade filled cases. They are

Fahys “Permanent,”
Fahys “Bristol” and
Fahys “Montauk” Cases.

All of Fahys Cases are made with our patent one piece pendant, eliminating all solder.

JOSEPH FAHYS & CO.

New York

Chicago

Boston

San Francisco

A FINE LINE *of* DIAMONDS

Diamond Cutters
Private Lake

Fine Fishing
for
Retail Jewelers



Investigation
Will Quickly
Demonstrate
That Fishing
in These
Waters
Pays Well

J.R. WOOD & SONS

The INVITATION

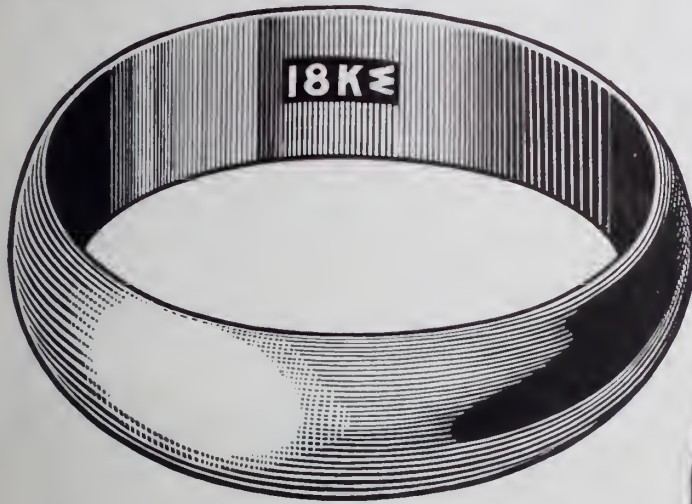

WE INVITE YOU to purchase the best wedding rings made — wedding rings of our manufacture; fully guaranteed as to plump quality and perfect finish.

With all their excellence, our prices are the lowest.

J. R. WOOD & SONS

WEDDING RING MAKERS

2 Maiden Lane, Corner of 170 Broadway
NEW YORK

The Big Dipper

Will Dip Up Profits For You



THE
BEST IN EVERY
GRADE

CHICAGO
701 Heyworth Bldg.

Ask your Jobber

NEW YORK
Maiden Lane

STARWATCH CASE CO.

LUDINGTON, MICHIGAN

COPYRIGHTED BY T. F. KENNEDY



YOU
 CAN SECURE THAT
 CLASS PIN ORDER
 BY SHOWING
 OUR DESIGNS AND SAMPLES.
 WE ARE HEADQUARTERS.
 WRITE TO EITHER FACTORY
 WENDELL & COMPANY,
 103 AND 105 WILLIAM ST.,
 NEW YORK.
 57 WASHINGTON ST.,
 CHICAGO.

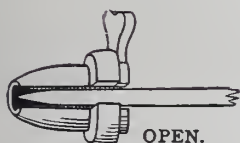

OPEN.

WENDELL'S PERFECT SAFETY CATCH

SETS CLOSE TO BODY OF PIN.
 PROTECTS POINT OF PIN TONG.
 HANDILY LOCKED AND UNLOCKED.
 ABSOLUTELY SECURE.

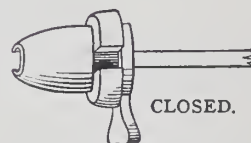

CLOSED.

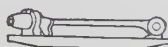

Wolcott Manufacturing Co.



PATENTS PENDING

The Fashion



Collar Pins



An absolutely new article which sells at sight. Try it

MANUFACTURED IN ROLLED PLATE BY

Wolcott Manufacturing Co.

71' PECK STREET, PROVIDENCE, R. I.

NEW YORK OFFICE, 14 MAIDEN LANE

JUST THE SAME AS EVERLASTING

ALL things must yield to Father Time—nothing is indestructible.
Yet it is quite true that

WADSWORTH PERMANENT

watch cases are “just the same as everlasting,” for they will wear so much longer than anybody expects them to that, in the end, they will be carefully laid away to be cherished with the other family heirlooms.

Chaste and artistic in design, perfect in workmanship and truly permanent, they represent the maximum of value, salability and satisfaction.

They would cost more if they were solid, but they would be no more attractive, nor would they give better service.

The Wadsworth Watch Case Co.

FACTORY
DAYTON, KY

CHICAGO
COLUMBUS BUILDING

SAN FRANCISCO
717 MARKET STREET

NEW YORK
49 MAIDEN LANE

Any Hour in the day, you can depend upon finding a Dueber case among these late designs, which will please your customer.

(25 yr 14 K.)

Hampden movements, from the dainty "Four Hundred" series for ladies, to the unparalled 16 size "Wm. McKinley," are cased at the factory.

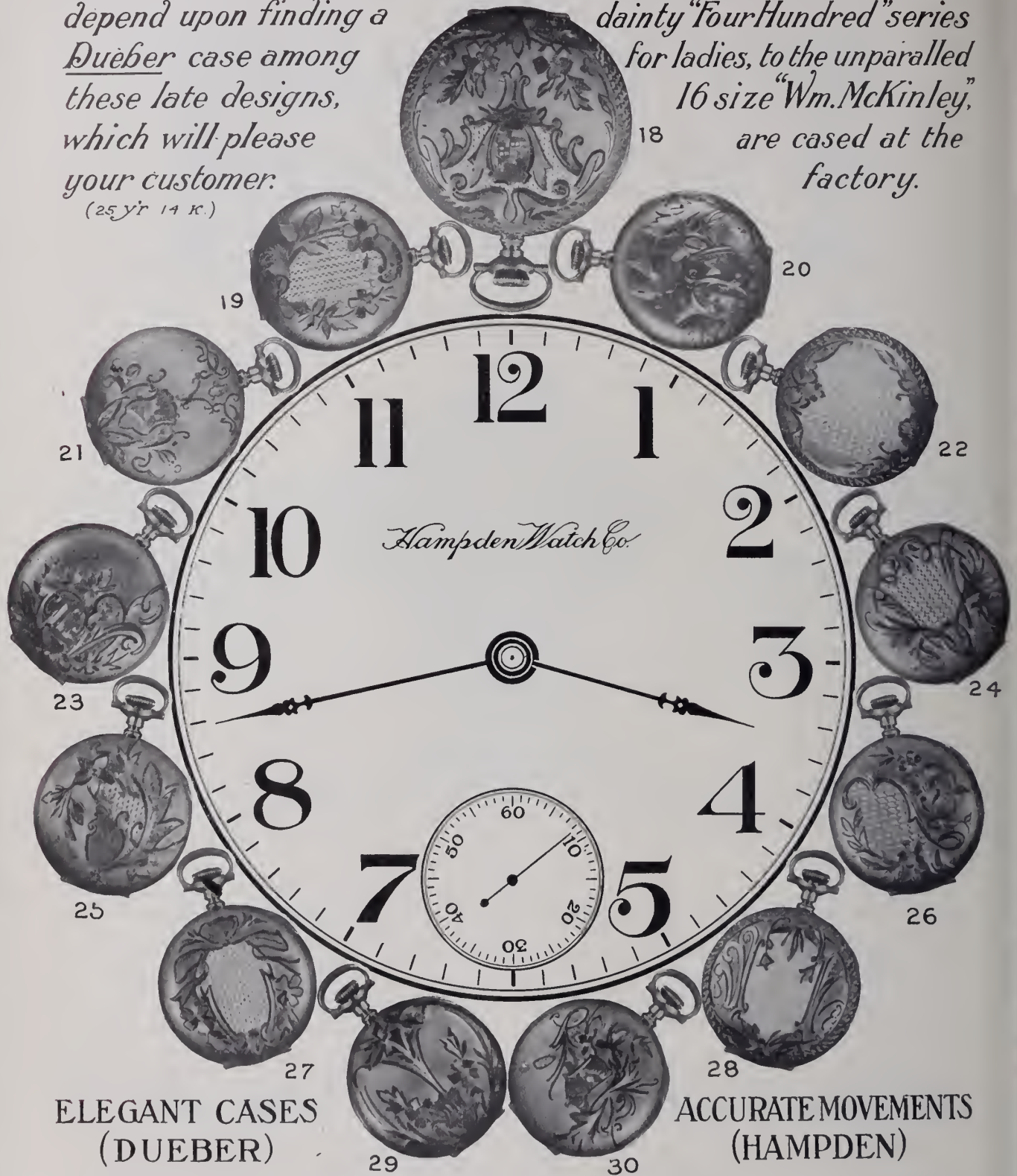

**ELEGANT CASES
(DUEBER)**

**ACCURATE MOVEMENTS
(HAMPDEN)**

Buckles



OUR BUCKLES are dress accessories that beautify what is already pretty in apparel. They constitute a welcome addition to the plainest garments or meet the strangest caprices of a strangely capricious sex—such are the volume and variety of our line. The range develops from buckles of Puritan simplicity to those elaborate curves and scrolls affected at the present time. All designed within the bounds of propriety, and calculated to please alike the exacting and indifferent. Etched, Plain, Fancy Die and Hand Engraved. Illustration, No. 2896, actual size; No. 2897, smaller size, same design. We also make these in belt pins. Sterling Silver of substantial weight.

Established 1861

R. BLACKINTON & CO.

TRADE  MARK

SILVERSMITHS

3 Maiden Lane, New York

Factory: North Attleboro, Mass.



A
**Novel
 Ash
 Receiver**



¶ The 4-in-1 ash receiver shown here is convenient for the man who entertains his friends at home. It consists of four ash receivers which are nested into one as shown in illustration. They may be separated and passed around for the use of the guests.

¶ They are good sellers with the retail jewelers.

Send for illustrated catalog showing our complete line.



No. 929—Extreme diameter 3½ inches.

Furnished in Silver-Plate, Copper or Polished Brass.



WITH THE PARTS NESTED.

New York Showrooms
 BROADWAY, COR. PARK PLACE
 Opposite Post-office

S. STERNAU & CO.

*Makers of Coffee-machines. Fancy Teakettles
 Chafing-dishes and their Accessories, Smoking Sets,
 Alcohol Stoves, Coffee and Tea Pots, etc.*

Office and Factory
 195 PLYMOUTH STREET
 BROOKLYN, N. Y.



WE show herewith a new style bag—an exceptionally strong, stylish, snappy article.

Our new Spring line is complete—covering the entire range of bags—all shapes, all the different styles of mesh—the largest assortment of frames ever shown. Every piece stamped. W. & D. an absolute guarantee of satisfaction.

Your Jobber has them.

WHITING & DAVIS
 PLAINVILLE (Norfolk Co.), MASS.

New York Office, 7 Maiden Lane

WHITING MFG. COMPANY

Silversmiths



The Outlook

To form a clear and discerning forecast of the probable course of business during the coming year is of vital consequence to every Retail Jeweler.

The timidity bred of an undue pessimism, is as mischievous in its consequences as the rash confidence resulting from an overweening optimism.

The Whiting Company's intimate knowledge of existing conditions, in all sections of the country, is of such a nature as to have encouraged them to make special efforts to meet the already growing demand for goods of acknowledged excellence.

The far-seeing Jeweler, therefore, when replenishing his stock, will give attentive consideration to the established reputation of *Whiting Silverware* for convincing quality and attractive design.

Broadway and Nineteenth Street
New York

THE HOME OF THE CELEBRATED CARMEN BRACELET

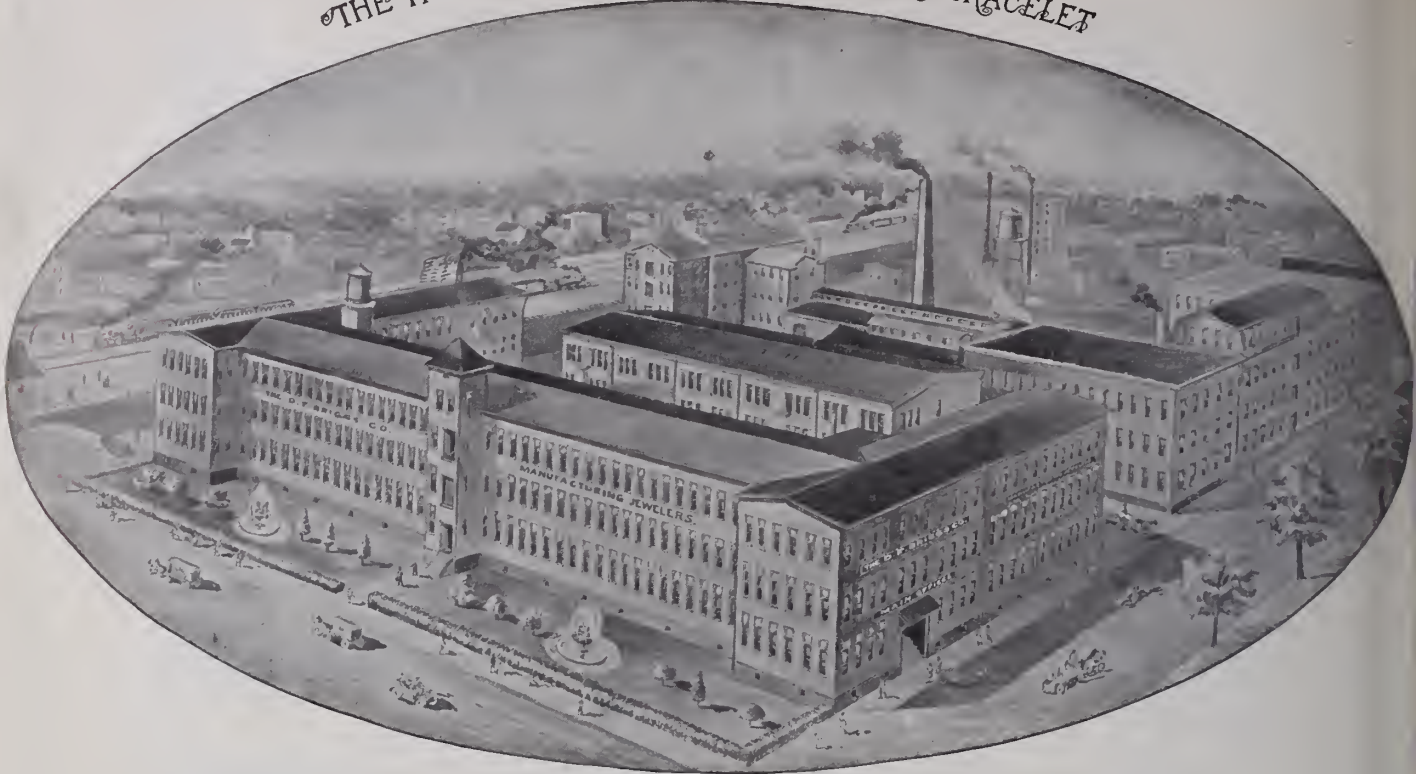

The D. F. Briggs Co.
Attleboro, Mass.

The "BEST" Safety Fob



F 447
E 21

Bates & Bacon

ATTLEBORO
MASS.

High Grade Gold Filled

- Gents Vest
- Dickens
- Safety Fob
- Secret Locket
- Lorgnette
- Eye Glass

CHAINS

Bracelets, Lockets, Chatelaines

NEW YORK:
9 Maiden Lane

CHICAGO:
103 State Street

The "WINNA" Bracelets
Strongest Secret Joint and Catch on the Market

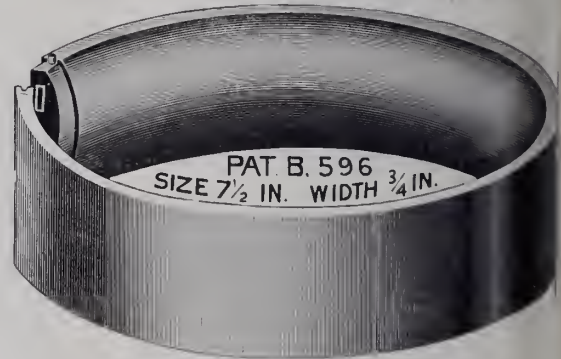

PAT. B. 596
SIZE 7 1/2 IN. WIDTH 3/4 IN.

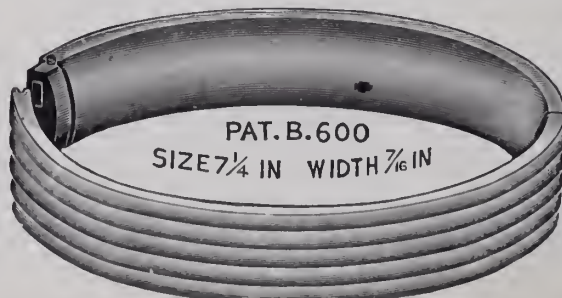

PAT. B. 600
SIZE 7 1/4 IN WIDTH 7/16 IN



PAT. B 598
SIZE 7 1/2 IN. WIDTH 3/4 IN

MR. RETAILER: "Lift the Lid"

just enough to show your customers
a few SOLIDARITY GOLD WATCH
CASES and you'll do business all
right. :: Your jobber can help you.

Solidarity Watch Case Company

Established 1885

54 Maiden Lane, New York

General Selling Agents:

JOHN W. SHERWOOD

:: ::

FRANK E. HARMER

*PURSE
AND
CARD CASE*



*A
METAL
NOVELTY*

THE CHARM OF NOVELTY is felicitously exemplified in these stylish Cases. The taste for "combination" is catered to in a new way. Fashioned of German Silver, rich effects are produced in

ENGINE TURNED DECORATION.

Such unique creations merit the special attention of the trade. Samples will be sent on request. Gun Metal Cases also for mourning or for the elderly. The appeal of the whole line is irresistible. Prices: from \$5.25 to \$7.50.

D. Lisner & Co. *Creating Importers of*
Jewelry Novelties
One-Forty Fifth Avenue, cor. 19th St., NEW YORK

The Best Selling "Thread" Pattern in the Trade



The SMITH "PILGRIM"

There never has been a more artistic and lasting design than the Smith "Pilgrim." It is characterized by simple elegance, refinement and dignity of design, and grateful absence of over-ornamentation. The Smith "Pilgrim" pattern will remain permanently in demand. Include "Pilgrim" in your stock. It is without question the best selling "thread" pattern in the trade to-day. Made in all the fancy pieces.



FRANK W. SMITH CO. MANUFACTURERS OF STERLING SILVERWARE Gardner, Mass.



TRADE MARK



WHILE conditions are gradually becoming normal, yet some stimulus is required by the jeweler to create a demand for goods. This can be most satisfactorily accomplished by displaying a line of jewelry which, by its attractive appearance, excellent finish, and moderate range of price, is bound to interest the average purchaser. Our lines meet these requirements exactly and you are bound to readily dispose of our "Sellers." Our representatives will be pleased to demonstrate this more effectively by showing the lines.

Special orders and jobs always receive particular attention and we will ship anything desired in diamonds, watches  or jewelry. Elk and Fraternal Order of Eagle goods a specialty. The  "Rose" our trade-mark is a symbol of quality and excellence.

HENRY FREUND & BRO.,

71 NASSAU STREET, NEW YORK CITY.

The KREMENTZ LINE of SERPENT JEWELRY

IN
NECKLACES
AND
BRACELETS

MOUNTED WITH DIAMONDS, SAPPHIRES,
AMETHYST, TOPAZ, TURQUOISE MATRIX, ETC.
Bracelets Are Supplied With Solid 14-Kt. Gold Springs

NECKCHAINS of Any Length Desired



Bracelet, 2098.
Neckchain, 2140.

Necklace, 2122.

Bracelet, 2118.
Neckchain, 2129.

KREMENTZ & CO.

Manufacturers of

Fine Gold and Enamel Diamond Jewelry in 14-Kt. Only

MADE EXCLUSIVELY FOR FINE RETAIL JEWELRY TRADE

BRANCH
San Francisco Office
722 Shreve Bldg.

Factory and Main Office
NEWARK, N. J.

BRANCH
New York Office
1 Maiden Lane

THE VIRTUES OF FLAT BACK STUDS

TRADE



MARK

THE PLAINEST and simplest is the stud for a gentleman. To these virtues the Flat Back Studs add the element of comfort. They are least likely to chafe the flesh or wear the underclothing. Points your best customers will appreciate.

TRADE



MARK

DURAND & CO.

49-51 FRANKLIN STREET
NEWARK, N. J.

TRADE **14** MARK

OSMUN-PARKER MFG. CO.
MAKERS OF
Fine Pearl and Diamond Goods
338 Mulberry Street
NEWARK, N. J.

ENOS RICHARDSON & Co.

MANUFACTURERS OF

14-K GOLD JEWELRY



- HANDY PINS TIE CLASPS
- SAFETY PINS VEIL PINS
- BROOCHES HAT PINS
- FLAT LINKS SCARF PINS
- DUMB-BELL LINKS BARRETTES
- FOBS BELT PINS
- 10-K AND 14-K NECK CHAINS AND GUARD CHAINS
- PLAIN AND JEWELLED LORGNETTE CHAINS

23 MAIDEN LANE, NEW YORK



The R. S. Cigar Cutter

In Sterling Silver, Plain and Engraved; and 14 k. Gold, Plain and Engraved, also Set with Diamonds.

A Novelty

Unlike all other cigar cutters, this one lies flat in the pocket—does not get out of order.

A Good Article



We Push It

Our advertising makes the customer want it; his friend sees it and he wants it. An endless chain of customers.

A Good Seller



Trade supplied by

Enos Richardson & Co.

23 Maiden Lane, New York.

G. R. HOWE
W. T. CARTER
W. T. GOUGH

ESTABLISHED 1841 BY A. CARTER

F. R. HORTON
F. W. STANBROUGH
H. L. FARROW

CARTER, HOWE & CO.

MANUFACTURERS OF

GOLD JEWELRY

Bags and Purses in Gold and Silver

9-11-13 Maiden Lane, New York

Factory, Newark, New Jersey



SOLID GOLD COMBS

From \$1.50 Upward

A Snappy New Spring Line
in

Plain and Engraved Bands,
also

New Effects in Pierced Tops

14k.—Everything in Gold Jewelry—10k.
Brooches, Barrettes, Buckles, Bracelets,
Pendants, Festoons, Emblems, Hat
Pins, Fobs, Scarfs, etc.



2 Maiden Lane, New York

UNIQUE GEMS

SEMI-PRECIOUS CEYLON, URAL and NATIVE

GEMS My Specialty

Prices the Lowest. Sample Papers sent on Request
to Reliable Jewelers and Manufacturers.

Louis J. Deacon, Atlantic City, N. J.

I. N. LEVINSON, President

ESTABLISHED 1865

H. S. MORRIS, Sec. and Treas.

S. COTTLE COMPANY

Makers of High-Grade Gold and Silver Novelties

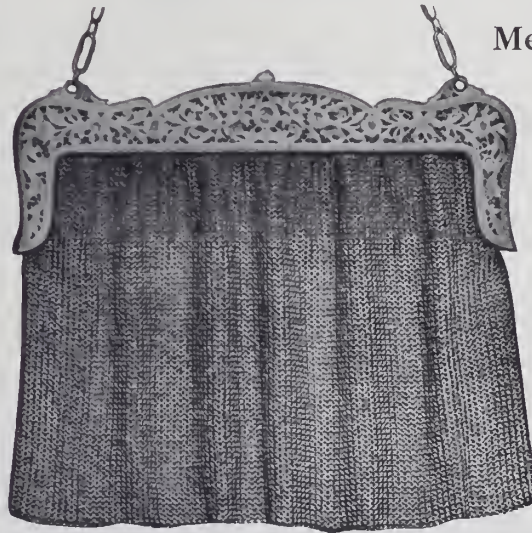

Mesh Bags Buckles
Card Cases
Vanity Cases
Purses Chatelaines

Our new line for Spring is now ready for inspection. Many new and artistic designs are shown. We wish to thank our many patrons for their past favors and hope for a continuance in the future.

31 EAST 17th STREET, NEW YORK

PARIS, 28 Rue D'Hauteville

FRANKFURT, a M., Hanse-Haus, 9 Stiffstrasse

SCARF PINS



Jade, Coral, Opal Matrix, Star-Sapphires, and
other stones, in 14k. plain edge.

35 Maiden Lane,
New York.

Geo. O. Street & Sons.

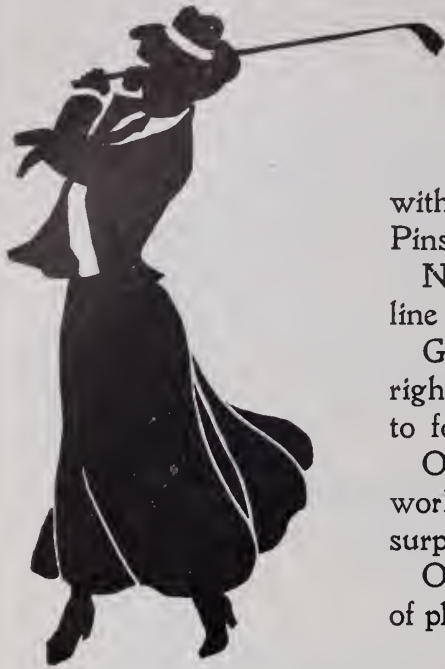

**We have made
... a Hit ...**

with our new Buttons and Scarf Pins.

Now is the time to select your line for 1908.

Get the right goods at the right prices and results are sure to follow.

Our 10 K. line is unequalled in workmanship and finish, and unsurpassed in quality.

Our trade-mark is a guarantee of plump 10 K.

KELLER JEWELRY MFG. CO.

Manufacturers of Fine Gold Jewelry

Brooches, Link Buttons, Locketts, Scarf Pins, Combs, Fobs, Tie Clasps, Charms, Lorgnette Chains, Neck Chains

64 NASSAU STREET, NEW YORK

Factory, 251 N. J. R. R. Avenue - - - NEWARK, N. J.

"THE BRACELET HOUSE"

GOLD BRACELETS of every kind
For WOMAN, MISS OR BABY

KENT & WOODLAND

16 John Street, New York

Factory: Newark, N. J. San Francisco: Julius A. Young

ACTUAL
SIZE.



SEED-PEARL NECKLACES IN ALL SIZES.

OSMERS-DOUGHERTY CO.

MANUFACTURING JEWELERS

291-293 SEVENTH AVE., NEW YORK

Bet. 26th and 27th Sts. Telephone, 913 Madison.

DEALERS IN

BAROQUES, PEARLS and
FANCY STONES



DESIGNING

AND

SPECIAL ORDER WORK

Insure Your Life

L. A. Miller

Special Agent of the

**Equitable Life
Assurance
Society**

will show to any who may be interested Sample Annual dividend policies on the

LIFE, LIMITED PAYMENT, ENDOWMENT, and TERM PLAN

ADDRESS

L. A. Miller

Special Agent

180 Broadway, N. Y.



FANS

AND FRENCH

JEWELRY NOVELTIES

THE latest European Novelties in all grades of

FANS

Lace, Painted and Spangled effects, mounted on bone, ebony and mother-of-pearl sticks.

Our goods are made especially for the jewelry trade.

Send for selection, mentioning price.

LEWY & COHEN

Importers of Fans, Jewelry Novelties, Festoons, Buckles, Chains, Necklaces, Collars, and Jet Goods, Etc.

530 Broadway, New York



Black Enameled Jewelry

OUR SPECIALTY

THE reports from the fashion centers of the world are that

Black Jewelry

of all kinds, both for mourning as well as regular wear, is the latest fad.

Jewels of all kinds mounted this way show up to their best advantage.

We
Make
Everything
in Black

**H. J. Hedges
& Co.**

MAKERS OF 14 K.
JEWELRY

14 John St., New York

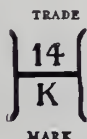

BUY GOODS WITH A TRADE-MARK



BANGLES
BROOCHES
BANGLE BRACELETS

HANDY PINS
TIE HOLDERS
VEIL PINS

A General Line of Fine Jewelry

BIPPART, GRISCOM & OSBORN

OFFICE AND FACTORY
Newark, N. J.

NEW YORK SALESROOM
1 West 34th St.

Links for Summer Shirts

APPROPRIATENESS is a virtue. There are Links that seem to belong to the Summer shirt. These Gem Links are an example. They strike the true note of color. Stones:

AMETHYST, TOPAZ, GARNET
CHINESE JADE, NEW ZEALAND JADE

Scarf Pins to match emphasize the pleasing harmony. Good selling lines appealing to gentlemen of taste.

... Scarf Pins to Match ...

Day, Clark & Co.

MAKERS OF 14-KT. JEWELRY
23 MAIDEN LANE
NEW YORK



LOCKETS ONLY

S. F. Myers & Co

WHOLESALE JEWELERS
47-49 Malden Lane
New York

Modern goods—modern prices—modern methods—they talk for us.

For the trade only—our new, big catalogue, with 100,000 items, sent free.

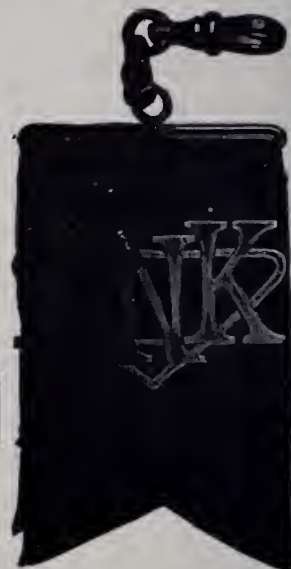

Monograms

INITIALS
AND
FOBS

Our
Specialties

Write for Catalogue,
Prices and Discounts.

CHICAGO
ART METAL
WORKS

63 Lake Street
CHICAGO, ILL.

Registered



U. S. Pat. Office



Pat. Applied for
NUMBER
8482

Latest Design Appropriate for Easter

WIGHTMAN & HOUGH CO.

NEW YORK OFFICE
3 Malden Lane

Main Office and Factory } 7 Beverly St.
PROVIDENCE, R. I.

“If It Is Chopard’s Idea, It’s Ideal”

MERIT, is the quality which singles out whatever is worthy of notice. That Chopard’s productions have merited this distinction is not because we say so, but because our records show a growth, year by year, which speaks eloquently for the sterling quality of our wares.



To single out from our newest importations any one, or a few articles, would be unjust to the others, so we call your attention to our line in general and these in particular:

Fancy Combs, Brooches, La Vallieres, Hatpins, Buckles, etc., also our complete assortment of **Jet Jewelry** and **Pearl Strings**.

Selection Packages sent upon request to all reliable dealers.

CHOPARD FRÈRES

Factory, 35 Rue des Trois Bornes,
PARIS, FRANCE

NEW YORK, OFFICE
56 Maiden Lane

INFORMATION

The right kind of information—the kind that will help you in your daily business work—information that will save you many a dollar is found in our Yearly

GREAT

American Jewelry Catalogue

ASK FOR IT

THE OSKAMP NOLTING CO.

Mammoth Wholesale Jewelers

419-415-417 Elm Street CINCINNATI, OHIO

TRADE



MARK.

SNOW & WESTCOTT

21 MAIDEN LANE, NEW YORK

JAMES P. SNOW

CHAS. E. WESTCOTT

Makers of Fine Gold
Jewelry

ESTABLISHED 1834

Trade-Marks of the Jewelry
and Kindred
Trades. Second Edition. Price, \$3.00.
The Jewelers' Circular Publishing Co.

THE BEST
SOLID GOLD CHAINS

THE CHEAPEST

They stand the test of time and have done so for 56 years.

Supreme in
QUALITY
DESIGN
FINISH
WORKMANSHIP



We Sell Direct. We Have No Salesmen. Eliminating all unnecessary expenses in making and selling enables us to sell at the lowest possible price. Send for catalogue.

Trade  Mark
1850 1907

ALOIS KOHN & CO.
16-18 Maiden Lane, New York
Makers of Gold Chains of every kind



While your business is somewhat dull you will find it to your advantage to look up the local order for

CLASS PINS

Write us for Catalogue J 30, and Samples

THE CHAS. M. ROBBINS CO.

MANUFACTURING JEWELERS AND ENAMELERS
ATTLEBORO, MASSACHUSETTS



MANUFACTURER OF HIGH-GRADE
DIAMOND MOUNTINGS

Prompt Attention
Given to Special
Order Work :: ::



Estimates and
Designs Submitted :: :: :: ::

Patented October 24, 1905.

DIAMONDS RECUT AND REPAIRED

JULIUS WODISKA, 40 John St., New York

GARREAU & GRISER
68 & 70 Nassau St., New York
LAPIDARIES. PRECIOUS STONES
GEMS in Unique Cuttings



DIAMOND MOUNTINGS

of any description in gold and platina

Order Work a Specialty

HENRY BASCHKOPF

47-49 Maiden Lane

New York, N. Y.



Fluffy Meets the Drummer Boys

"Where are you going, my pretty maid?"
 "Out traveling on the road," she said.
 "What is your line, my pretty maid?"
 "Fluffy Ruffles Locket, Veribest, Sir," she said.
 "How do they please and wear, my pretty maid?"
 "Lifetime guaranteed, as good as gold," she said.

"Fluffy Ruffles"

(TRADE-MARK)

LOCKETS

VERIBEST



LEDERERMAK LOCKETS

Sold Exclusively by Jobbers Everywhere

Manufactured and Guaranteed by
S. & B. L. ★ CO.

9-11-13 Maiden Lane, New York City. 100 Stewart St., Providence, R. I. 131 Wabash Ave., Chicago, Ill.

Pierceless Ear Screws

We are making a complete line of these popular goods. Samples upon request.

Also a new line of

- Brooches
- Scarf Pins
- Baby Pins
- Links
- Studs
- Crosses
- Ear Rings
- Rings
- Neck Chains

We have manufactured Gold jewelry for over fifty years and our goods have stood the test of time.

DON'T NEGLECT TO SEE OUR LINE.

Wm. C. Greene Co.

Established 1849 Incorporated 1906

MANUFACTURERS OF GOLD JEWELRY

101 Sabin Street,
Providence, R. I.

Send for the Latest Styles in MONOGRAMS AND INITIALS

as manufactured by
THOMAS J. DUNN CO.

101 Chambers St., New York
 Makers of exclusive styles in
MONOGRAM FOBS

in Gold, Sterling and Rolled Gold Plate.
 Our 1908 Ladies' Belt Buckles are most original and artistic.

Specialties in the Monogram and Initial line.
 Send for Illustrated Sheets.

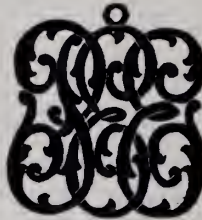

Roger Williams Silver Co.,

PROVIDENCE, R. I.

Sterling Only.

RICH DESIGNS :: :: :: Photos. on Application.

CHARLES M. PRIOR, Designer

We have ready many new designs. Call or write. Etching is more popular than ever and we do it in the finest style.

'Phone 1639 Gramercy 24-26 East 21st St., NEW YORK

Gems and Precious Stones

Cloth, Postpaid, \$1.00

Published by

The Jewelers' Circular Pub. Co.

11 John Street NEW YORK

Orders Prove Our Goods Sell

We make for the Jobbing Trade the following lines of Solid Gold Jewelry:

Rings, Scarf Pins, Studs, Brooches, Charms, Baby Pins, Handy Pins, Chain Sets, Link Buttons, Hair Barrettes, Crosses, Ear Screws, Pierceless Drops, Cameos in all styles, etc.



Insist upon seeing the designs of Gold Jewelry made by the

E. L. Spencer Company

95 CHESTNUT STREET
PROVIDENCE, R. I.

NEW YORK OFFICE
9-11-13 MAIDEN LANE

(SAMPLES ONLY)

CUFF BUTTONS
 IN EVERY POSSIBLE VARIETY
 WE ARE THE LARGEST EXCLUSIVE MAKERS OF 10-K JEWELRY
 ASK YOUR JOBBER FOR P. & B. LINES OF
 Cuff Buttons, Crosses, Beadnecks, Tie Clasps,
 Brooches, Baby Pins, Scarf Pins, Bracelets,
 Locketts, Fobs.

NEW YORK
 OFFICE:
 65 NASSAU ST.

POTTER & BUFFINTON CO.
 PROVIDENCE, R. I.

"HOLD-ON" CLUTCH

FOR SCARF PINS AND BROOCHES

14K. GOLD PLATE
 SUPERIOR TO ALL OTHERS

PRICE 50 CENTS

ADVANTAGES:

1. *It Holds*—The harder you pull, the tighter it holds.
2. *To Release*—Raise the clutch and pull the ball.
3. *All One Piece*—No parts to lose.

HOLD-ON CLUTCH CO. 33 GOLD STREET NEW YORK

Pat. May 20, '02
 To Release
 Pull the Ball

Pat. May 20, '02
 Attached
 to Scarf Pin

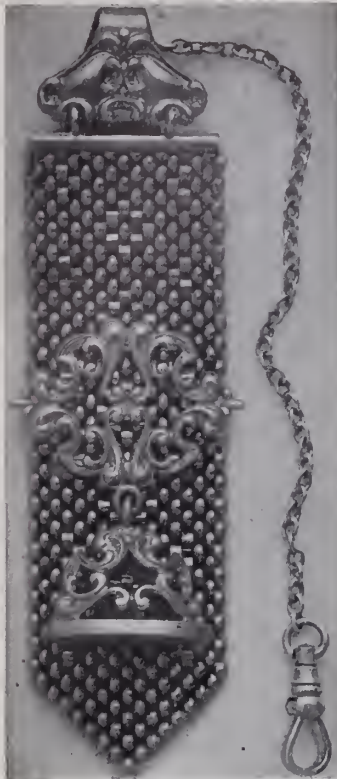

Roller Chain

OUR SPECIALTY

Do not forget that we still continue to show the best line of these goods on the market, in Fobs, Bracelets and Neck Chains. These wear longer, give better satisfaction than any metal fob made, and our designs are up-to-date. Also our line of chains of all kinds find a ready market among the best trade, both in 1-10 and a medium wearing grade.

We also make a nice line of Brooches, Hatpins, Scarfpins, Barrettes, etc., that should demand your attention.

Ask your jobber, and if unable to obtain them from him, advise us who he is, and we will make arrangements for you to get them.

B. S. FREEMAN CO.

ATTLEBORO FALLS, MASS.

Chicago Office, J. T. Edwards, 103 State St., Chicago, Ill.

Perennially Popular

THE best evidence of the popularity of our various lines is the increasing demand for them and our consequent growth. Our jewelry is unexcelled in every quality that contributes to serviceability and appearance. The designs are artistic enough to court that investigation which results in sales.

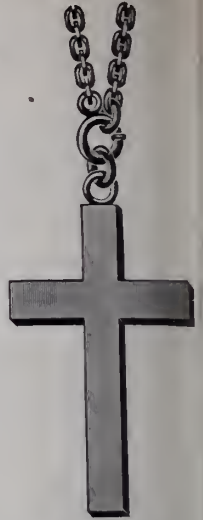

Ask to see our line of

**CHAINS
CHAIN PENDANTS
CROSSES
AND BRACELETS**

The

**Kenilworth
Bracelet**

particularly, the strongest
on the market.

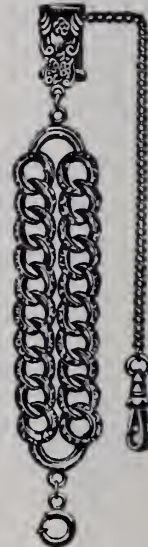

**DORAN,
BAGNALL & CO.**

North Attleboro, Mass.

OFFICES

New York: 194 Broadway
Chicago: 42 E. Madison St.
San Francisco: 91 Drumm St.

EVERYTHING IN LOCKETS AND CHAINS.

THE BASSETT JEWELRY CO.,

PROVIDENCE, R. I.

"GOLD MEDAL"

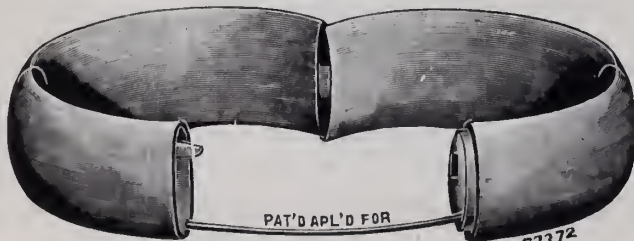

Gold Filled
QUALITY

"Geraldine
Farrar"
Bracelet

The only "SECURON" Hinge Bracelet
Made in all widths, sizes, fancy and plain

Guarantee "Pr. St. Co." Mark Inside

PROVIDENCE STOCK CO.

9-11-13 Maiden Lane
NEW YORK CITY

100 Stewart Street
PROVIDENCE, R. I.

131 Wabash Avenue
CHICAGO, ILL.

10K. GOLD BRACELETS

New and Original
— Designs In —

**BANGLE, JOINT
— AND —
CATCH SIZES**

Scarlet Pins, Ladies' Ring
Earrings and Handy Pin

In a great variety
of designs

TRADE MARK

THE
Edwin Lowe & Co., Inc.

F.W. BODWELL, Pres. & Gen. Mgr.

116 Chestnut St., PROVIDENCE, R. I.

New York Representative: Western Representative:
E. T. Wilson, 180 Bway. S. H. Brower

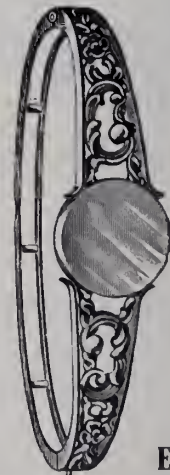

A MILLION RINGS ARE NO
worn that are loose on the finger a
need Wells Perfect Ring Adjusters
hold them in place. Why not fit the
and make a good profit and new cu
tomers.

Ask your Jobber for them
Sold in 1 doz. assorted sizes in packag
as follows: 10 K. Gold, \$3.75; Gold Fille
\$2.00; Metal, 85 cents.

CHESTER H. WELLS, Jeweler, Meshoppen, Pa.

O. M. DRAPER CHAINS

VEST CHAINS, NECK AND GUARD CHAINS

Superior Quality, Artistic Designs, Unparalleled Finish. No line can be complete without a representation of these reliable goods.

Sold only to the jobbing trade.

Estate of O. M. DRAPER

Factory, No. Attleboro, Mass.

NEW YORK OFFICE
37 Maiden Lane

SAN FRANCISCO
506 Chronicle Building

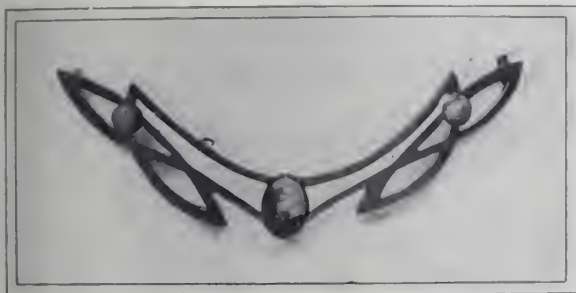

Women of fashion at present are wearing ornaments for the hair more than ever. We anticipated such a demand for these goods and have on hand a large assortment of Rhinestone, Coral and Jet

BARRETTES

from which to select. We also have a magnificent line of Coral Hat Pins, embodying many catchy designs, exclusive carvings and filigree effects, ranging in price from \$4.00 to \$15.00 per dozen.

SELECTION PACKAGES SENT UPON REQUEST

M. GUGENHEIM, Importer of

Brooches, Festoon Chains, Combs, Hat Pins, Collars, Jet Goods, Mesh Bags, in German Silver, Gilt Metal and Sterling

NEW YORK OFFICE: 33 Union Square, Decker Building

PARIS: 32 Faubourg Poissoniere



Veil, Cuff and Baby Pins

An immense line. Many new designs—supplementing our staple patterns—all of acknowledged beauty, and easily sold.

Cameos

A revival of an old-style decoration too good to remain in oblivion. Shell, Coral and others, mounted as Brooches, Stick Pins, etc.

Swastika

Buckles Bracelets Buttons Charms Brooches Barrettes Combs, Hat Pins, Scarf Pins, Leather Trimmings



MILLER, FULLER & WHITING CO.

Manufacturing Jewelers
New York Office, 9-11 Maiden Lane NORTH ATTLEBORO, MASS.
WE SELL TO THE JOBBING TRADE ONLY



Do not have New Cluster Heads made

We repoint Clusters, Marquise, Princess and other fancy rings; we make them like new at very reasonable prices.

One trial will convince you that we do exactly what we claim. We make a specialty of all kinds of repairing. Write for price list—it will pay you.

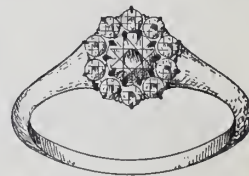

As received from Customer

ARONSON & SPIEGEL, 78 Nassau St., New York

As delivered to Customer



It's the Little Things that count.

The dainty little things that appeal at once to the casual observer. If it's useful, as well as ornamental, so much the better. Here is a LITTLE THING, so very useful and so pretty in design and finish, that you have but to show one to make a sale, and it yields a BIG PROFIT. It is called

The Automatic Eye-Glass Holder

Can be used as well for a Pencil Holder. It is made in Enamel, Gold, Silver and Rolled Plate, in a variety of artistic designs. We fully guarantee every Holder. We mean it, and will replace any Holder that fails to satisfy. Samples sent upon request. Send for catalogue.



Est. 1832. **Ketcham & McDougall, Manufacturers,**
37-39 MAIDEN LANE, NEW YORK.
ALSO MAKERS OF THE LEADING LINE OF THIMBLES.

The "SECURITY" Necklace Clasp

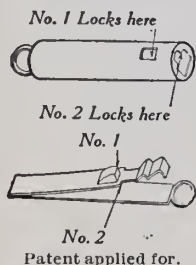

HEAR IT SNAP

Absolutely Secure and Simple. Cannot Pull Out
LOCKS IN TWO PLACES

Making it Doubly Secure
The Only Perfect Clasp

Ask Your Jobber or Write.

PRICES TO THE TRADE:

No. 1	No. 1.	10-Karat,	\$6.00 doz.
	" 1-B.	10 "	7.00 "
	" 1.	14 "	7.00 "
	" 1-B.	14 "	9.00 "
	" 2.	10 "	9.00 "
	" 1.	Platinum,	18.00 "
No. 1B	" 1.	Gold Filled,	2.00 "
	" 1-B.	" "	2.25 "
	" 2.	" "	2.50 "
No. 2	" 1.	Sterling Silver,	2.00 "

The Hoffman Novelty Co.,

Makers, 79-83 No. Pearl St., ALBANY, N. Y.

"CLINCH"



Safety Catch for Scarf Pins

Does not mar the pin. Nothing to get out of order. Simple and neat.

One turn to the right grips like a vise.

..FITS ANY SIZE PIN..

PRICES TO THE TRADE

No. 1	Gold Plated	\$1.50 doz.
No. 2	Roman Gold	2.00 doz.
No. 2	14k G'ld Pl'te	2.25 doz.

No. 1, 25c.

These well-known Razors, the quality of which is warranted, possess this great advantage, that they may be used for ten years before they require actual sharpening. Before using them it is necessary to rub them on good leather strop. Le Coultre's Stropps (to be had with the Razors) should be used in preference to others.

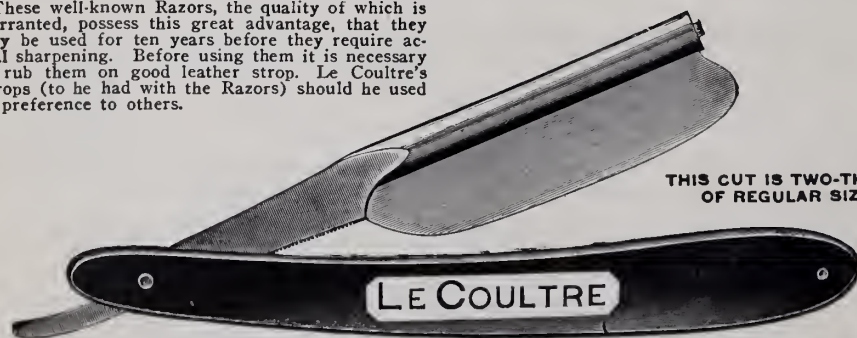

THIS CUT IS TWO-THIRDS OF REGULAR SIZE.

"SPECIAL"—Single Razors for Jewelers' Travelers at trade price.

MATHEY BROS., MATHEZ & CO.

Send for Price-list.

Sole Agents, 21 & 23 MAIDEN LANE, N. Y.

We have the most approved
Reducing Machines

Crees & Court
Die Sinks

21 Eddy St., Providence, R. I.



DIES

FOR

JEWELRY SILVERWARE

Medals
Emblems
Brass Goods

Write us for a Selection of
DESIGNS

-  1. Snap complete.
-  2. Outside of snap.
-  3. Inside of snap.

The E. P. H. Patent NON-PULL-OUT Neck Chain Snap

is a patented snap that insures the wearer against loss of

CHAIN or CHARM

for it positively will not pull out

Made in 10 and 14 Karat Gold and in Gold Filled.

Can be had of the following Wholesale Selling Agents:

- Messrs. W. Green & Co.,
81 Nassau St., New York
- | | |
|------------------------------|-------------------|
| M. Sickles & Sons, | Philadelphia |
| E. A. Cowan & Co., | Boston |
| E. & J. Swigart, | Cincinnati |
| Swartchild & Co., | Chicago |
| Nordman Brothers, | San Francisco |
| Leonard Krower, | New Orleans |
| A. Walker Co., | Providence, R. I. |
| Bauman-Massa Jewelry Co., | St. Louis |
| H. S. Meisley Co., | Lancaster, Pa. |
| The Edw. Lehman Jewelry Co., | Denver, Col. |

PRICES.

- 14 Karat—Small, \$7 per doz. net
Large, \$7.50 per doz. net
- 10 Karat—Small, \$6 per doz. net
Large, \$6.50 per doz. net
- Gold Filled—Small, \$2 per doz. net
Large, \$2.25 per doz. net

THE WASHBURN

SECURITY **MAGIC NUT**
Automatic Holder for ear studs, scarf-pin etc.
for all sizes of scarf-pin wire. Guaranteed.



EAR WIRES
for unpierced ears.



SAFETY CATCH
For Brooches, etc.
Can be applied to a work where pin tongue are used.

Open. Closed. Open. Closed.

Descriptive Circular on Application.
Pearl Drilling and Adjusting a specialty.
Special Order Work and Repairing.
C. IRVING WASHBURN, 12-16 John St., N. Y.

GEMS AND PRECIOUS STONES

Cloth, Postpaid, \$1.00.

Published by The Jeweler's
Circular Publishing Co.

11 JOHN STREET NEW YORK

Begin the New Year Right—Complete Your Stock with Right Goods

GOLD RINGS

Gold Scarf Pins

Gold Brooches

A Handsome Line of Seamless Wire GOLD FILLED RINGS

All ready for prompt delivery to the Jobber

OSTBY & BARTON CO.
PROVIDENCE, RHODE ISLAND

New York Office
9-13 MAIDEN LANE

Chicago Office
103 STATE STREET

The Bowden Rings

ARE COMPLETE IN VARIETY, CORRECT IN
QUALITY AND PERFECT IN FINISH. WE
MAKE EVERY VARIETY OF FINGER RINGS.

J. B. BOWDEN & CO.,

1 Maiden Lane.

NEW YORK.

The "Bryant" Rings.

WE have made the **Bryant Rings** for 50 years, and know how to make first class goods. The stone setting—which every retailer knows is a very important part of the work—we give special attention to. The **Bryant Rings** will help your reputation as a first class Jeweler.



TRADE-MARK

M. B. BRYANT & CO.,

NO. 7 MAIDEN LANE,
NEW YORK.

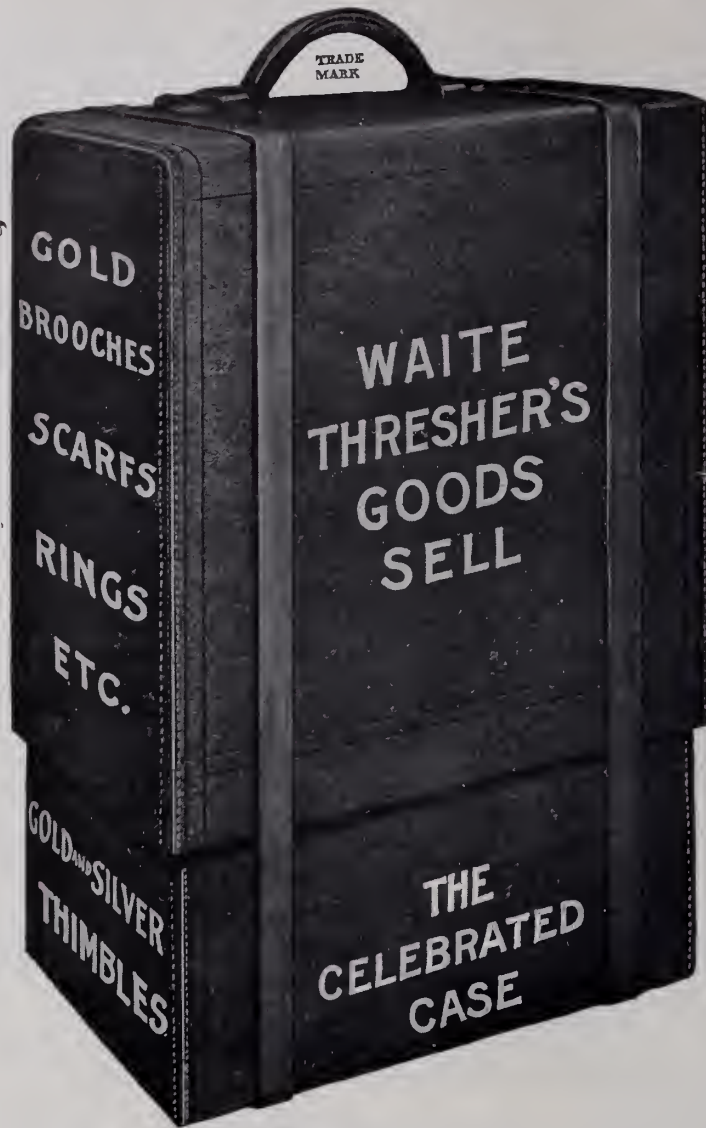

CAMEOS

Stone, Shell, Coral and Lava.
Rolled Gold Plate Mountings

SELECTIONS SENT TO
RELIABLE JOBBERS

Maintien Brothers & Elliot
North Attleboro, Mass.

RIBBONS

plain and fancy designs **Made to Order,**
in large or small quantities, to use with medals and
for club purposes. :: :: :: Correspondence invited.

JOSEPH LOTH & CO., Manufacturers, 65 Greene Street, New York

THE CROHN PATENT SAFETY GUARD

For Scarf Pins
Pins. The most
adjustable one invented. Price, \$1.50 per doz. For sale
by all wholesale jewelers and material houses. Same
by mail, 25c.; in 10k. gold, \$1.00; 14k., \$1.25. M. CROHN
Maker and Inventor, 48 and 50 Maiden Lane, N. Y.

Studs and Lapel
practical and of
price, \$1.50 per doz. For sale
by all wholesale jewelers and material houses. Same
by mail, 25c.; in 10k. gold, \$1.00; 14k., \$1.25. M. CROHN
Maker and Inventor, 48 and 50 Maiden Lane, N. Y.



The Gillette Safety Razor Set consists of a triple silver-plated holder and twelve double edged, thin, flexible, wafer-like blades (24 keen edges), packed in a velvet lined leather case. Price, \$5.00. Also made in Combination Sets in a variety of styles with toilet accessories retailing from \$6.50 to \$50.00 each.

Would You Have the Present Year Bring You Increased Patronage, Profit and Prosperity?

Do you realize that nearly every hour in the day some man is converted to the easier, quicker and more economical way of shaving himself with the

Gillette Safety Razor?

Our persistent and vigorous advertising in the leading publications of this country discloses — *and will continue to disclose* — beyond all question of doubt, the superiority of the "Gillette." It advocates the advantages of self-shaving and guides the man to your store with a five dollar bill to exchange for the best shaving device in this world.

You can readily see the wisdom of having the "Gillette" ready when he calls. The Standard Gillette Set retails at \$5.00 everywhere. Combination Sets from \$6.50 to \$50.00. Keep a good supply in stock. Write to-day for valuable selling information and prices.

GILLETTE SALES CO., 904 Times Bldg., New York City



Locket 2985—Old English



Bracelet with Joint
915—O. E. Engraved, Stones set as ordered, 2 3/8"
916— " " " " " " 2 1/2"
917— " " " " " " 2 3/4"



3863—Rose, Red Eyes, White Mouth
3862—Rose, no stone

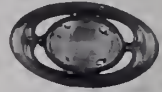

3842 Rose, set as ordered
3900 O. E. Set as ordered



3899—Rose, Red Eyes, White Mouth
3898—No stone

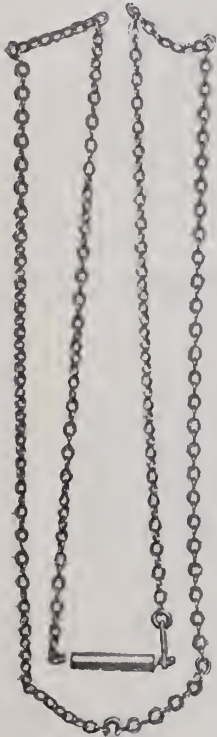

Neck Chain 294—16" long
Old English Chain
Roman Scrolls
Baroque Pearls and Japanese Jades



Hat Pin
847—Rom. Red Enam.
848— " Blue "
849— " Green "



Belt Buckle
3542—Rose, set as ordered
3543—Green, "
3544—Sterling Grey, set as ordered



851—Rose, "Real Malachite Stone
852—Green, Real Malachite Stone



844—Rose or Green Stones set as ordered



2978—Roman and Green Pearls and Brilliant
2977—No stone



Baby Pins
3869—Roman
3870—Old English
3871—Pearl Set, Roman
3872—Old English, Pearl Set



3005—Rose, no stone
3007— " Brilliant

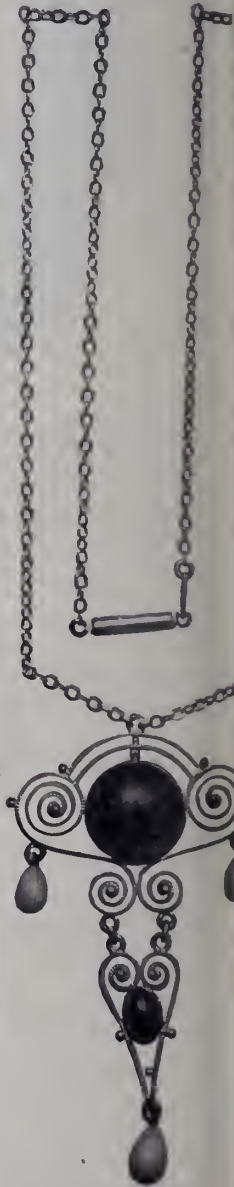

No. 298—16" Neck Chain C
Roman Scrolls
Jap. Jade Stones, 3 Real C
Pendants

Do You Realize

that Spring is near at hand and with it the certain demand for Good Selling Jewelry?

We offer this Season an exceptional line of Fine Gold Filled Goods, among which are Neck Chains and Pendants, Locketts and Charms, Link Buttons and Bracelets, as well as Brooch, Veil, Scarf and Hat Pins.

Each design is skilfully executed and beautifully finished.

Our Sterling Silver Ware includes many new styles in Toilet and Manicure Goods, Vases, Candlesticks and Novelties.

Theodore W. Foster & Bro. Co.

Manufacturing Jewelers and Silversmiths

100 RICHMOND ST., PROVIDENCE, R. I.

NEW YORK 13 Maiden Lane

CHICAGO: Heyworth Bldg.

CANADA: Kingston, Ontar'io

THE JEWELERS' CIRCULAR

WITH WHICH ARE CONSOLIDATED
 THE HOROLOGICAL REVIEW
 THE JEWELERS' WEEKLY THE JEWELERS REVIEW

OL. LVI. WEDNESDAY, FEBRUARY 26, 1908. No. 4.

Ceylon Pearl Shells.

REPLYING to an American inquiry as to the opportunities for purchasing the shells of pearl oysters in Ceylon, Consul A. Creevey writes as follows from Colombo:

The price of pearl shells in recent years has varied from \$20 to \$35 per ton c. i. f. at continental ports. While supply and demand have been the chief factors in determining the price, the quality of the shell and the mode of packing employed have also had their influence. It is expected that the price in 1908 will be higher, as it is stated that there will not be a pearl fishery season, owing to unfavorable conditions on the oyster banks. Even when a large fishery is made it is sometimes impossible to secure large quantities of shells because of irregularities of shape and the prevalence of worms which eat the shells; so at times there are excessive excrescences.

The fisheries were conducted by the Ceylon Government up to two years ago, when they were leased to a company organized for the purpose. The company has sold the shells in "kottus," the buyer undertaking to move all, without regard to quality, from the shore. I am informed that the purchaser of the shells has not rendered satisfactory service, having left the worthless shells on the shore after sorting, and that the company contemplates canceling his lease. The banks lie about three days' sail from Colombo, and the buyer of the shells fears their removal between November and March, when the winds permit. Between April and October the banks are not approachable by sailing craft, owing to the monsoon. This season's shells are now being brought to Colombo, and it is expected that the kottus will yield between 600 and 700 tons of sound shells.

WINDOW-PANE SHELLS—EXPORT STATISTICS.

Samples of shells are forwarded (and may be seen at the Bureau of Manufactures, Washington, D. C.). With the pearl shell samples is a sample of shell known as "window pane." This is the product of a government fishery, and the annual yield averages below 300 tons. The sizes are between five and seven inches, and the price varies between \$70 and \$90 per ton, c. i. f. Continental ports.

The freight rate on shells packed in wooden cases is 15 shillings (\$3.65) per ton higher than the rate on shells in bags and shillings (\$1.22) per ton higher than on shells in barrels. Shippers favor the use of wooden cases, even though the rate be higher, as there is practically no breakage in the cases, while breakage is great in cased shells.

The export of pearl shells from Ceylon in the calendar year 1906 aggregated 13,809

hundredweights, consigned as follows: United Kingdom, 922; Spain, 40; Japan, 1,158; Italy, 1,000; Germany, 7,689; France, 2,971, and Austria, 29. The exports for the first ten months of 1907 amounted to 10,575 hundredweights, of which Germany took 7,002.

It would appear that there is a good opportunity for the establishment in Ceylon of a factory for the manufacture of pearl-shell goods, and that American capital might well be invested in such an enterprise. As none but perfect shells are exported, millions of other shells and fragments fit for manufacture are wasted each year, and these could be utilized by a manufacturing concern located here. A factory located in Ceylon could draw its supply of raw material from the neighboring shell fisheries as well as those of Ceylon, and the failure of a Ceylon fishery need not materially affect the supply.

Madagascar Grants Two Concessions for Government Pearl Fisheries on the West Coast.

OUR consul at Tamatave, Joseph G. Carter, writes that the government of Madagascar has recently granted two concessions for pearl fisheries, of which the following is a brief summary:

The grants cover the entire west coast, a distance of 1,000 miles, with the exception of 200 miles for which two concessions were made in the year 1906. The earlier grants attracted little interest, and apparently no efforts have been made to develop them. There are some indications that the two more recent concessions will be operated, perhaps jointly.

According to the text of the decrees, which have not been definitely approved, the authorization is personal and cannot be sold or transferred without the approval of the Governor-General. The use of divers, machinery, dredges and other apparatus and the establishment on certain points of the coast in the zone specified of installations necessary for the industry are permitted on the condition that such installation will not interfere with navigation, fishing or coast travel.

The terms provide for the payment of a tax during the first year with a stated increase per year. At the expiration of a specified period the tax is to be revised according to the prosperity of the undertaking. Every year a report of the installations made and the results obtained must be forwarded to the Governor-General. The concession may be canceled for failure to begin operations within a stated number of months; for abandonment of the work throughout any one year of the period of concession, except in the case of unforeseen circumstances; for non-payment of the tax,

or for renting or transferring without authorization. At any time when the interests of the colony or public services may require the privilege may be withdrawn without indemnity.

Artistic Offertory Basin Handsomely Jeweled and Enameled, Made for Trinity Cathedral, Cleveland, O.

THE illustration on the front cover shows an offertory basin, a beautiful example of the silversmith's art, which was presented to Trinity Cathedral, Cleveland, O., one of the finest buildings of its kind in the middle west.

The alms basin is of sterling silver and is beautifully enameled. A Champlève enamel in the center represents, with a touch of Byzantine mannerism, the Adoration of the Magi; this is surrounded by eight scenes from the life of Christ, executed in repoussé silver oxidized, and has an enameled border containing four medallions of the evangelists.

In the panels between the medallions are elaborate and vari-colored enamels studded with malachite, large carbuncles, topazes and crystals. The heads of the evangelists are noble and beautiful, conceived in the same spirit of love and reverence, as are the scenes from the life of Christ. It is purely Romanesque in design, perfect in its details; of the period and of a style well suited to the color motifs employed in the elaboration of this unique alms basin.

The central group, picture and cross, is set with jewels *en cabochon*. The ornamentation on the outer rim is in filigree. The arches and detail surrounding the subjects which are in bas relief, are beautifully chased in gray silver, contrasting with the gold mounting.

As a whole this piece is, without doubt, both in design and workmanship, one of the most beautiful specimens of ecclesiastical art and is worthy of taking its place in any age or period. It was made by the Gorham Co., New York.

Retail Jewelers of Hamilton, Ont., Enjoy Banquet.

HAMILTON, Ont., Feb. 20.—The retail jewelers of this place held a banquet at the Royal Hotel yesterday evening. Stuart Lees officiated as chairman. Among the speakers were George H. Lees, A. Levy, J. W. Millard, F. Claringbowl, W. R. Davis and Norman Ellis, Hamilton; E. M. Trovorn, secretary Retail Merchants' Association; Lionel G. Amsden, Edward Beaton and J. E. Brown, Toronto; George Smith, Kingston, Ont., and R. E. Robertson, Hagersville, Ont.

The committee of arrangements consisted of Alfred H. Baker, chairman; J. Levy, Geo. H. Lees and Thomas Binkley.

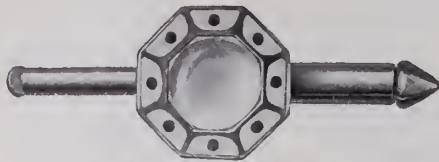

No. 4483

A New Shirt Stud

While we make without contradiction the largest and most varied line of shirt studs in the United States, we are continually increasing it by adding new up-to-date patterns.

The cut above is one from a number of new and original patterns in shirt studs, all having the satisfactory Larter back.

Made in 14K. gold only, with mother-of-pearl center, white enamel and gold border — This combination is not only attractive, but is in absolute good taste for dress occasions.

We also make loose link buttons and Larter vest buttons to match at moderate prices.

LARTER & SONS

21-23 Maiden Lane, New York, N. Y.

TRADE-MARK



REGISTERED IN U. S. PATENT OFFICE



No. 1598

A New Ring

The above illustration is one from a new line of rings for women in both 10K. and 14K. gold, which we are now adding to our stock.

Our rule is not to make the same patterns in both qualities; therefore the above pattern can be had in 14K. gold only, made with cabochon cut opaque stones in the following colors:

- Lapis Lazuli Dark Blue
- Dark Chinese Jade Dark Green
- Amazonite Light Green
- Epidote Olive Green and Red
- Turquoise Matrix, Light Blue and Brown
- Coral Pink

LARTER & SONS

21-23 Maiden Lane, New York, N. Y.

TRADE-MARK



REGISTERED IN U. S. PATENT OFFICE

THE OCCULT IN GEMS AND JEWELRY.

By C. W. Coumbe.

AUTHOR'S NOTE.—For the jewelry trade to hit upon something new, original and "taking" would seem to be an almost impossible task. But, if every line of original thought is exhausted, what is the matter with commencing over again from the beginning? Why not dig up and refurbish that which is so old as to be buried and forgotten under the dust of centuries? "Society," in search of novelty, has taken up the ancient rites of the mystics. Europe, in the lead, has its astrologers and soothsayers by the score in each capital, and among the social leaders the number of believers in the cabalistic art is legion.

A good maxim for the jeweler is: "Follow the trend of the times." If the desire for occult lore be rampant, why not be thereto subservient? Why not talk and teach the ancient lore of gems and jewels? And sell the ancient amulets and talismans?

With this idea in view, the present treatise is indited for the double purpose of assisting the manufacturing jeweler to what is known of the means and methods of the ancient mystics, and at the same time affording the retailer material on which to base a pamphlet concerning such wares of occult forms as their makers may supply him.

The cabalistic devices and information contained in this article are all obtained from ancient works that were considered, in their remote day, serious "scientific" reading. But the mysticism is treated by the author in a jocular manner, to furnish "text" for a retailer's pamphlet, because most modern members of the mystic circle don't like to be thought of as "really superstitious."

WHAT more entrancing theme these days of "isms" than ancient occultism! What more interesting facts for the



FIG. 1—CABALISTIC RING IN THE LONDESBOROUGH COLLECTION.

jeweler than the intimate relationship between occult rites, gems and jewels (better known as talismans)!

To Hermes Trismegistus (the trebly great) we owe the profound knowledge on which are based the occult sciences, astrology and alchemy. To him is given the reputation of laying the foundation stone on which are erected the many religions of later centuries. Undying interest attaches to the works of his followers, the Hermetics, named after him. Most important of all, however (from the jeweler's standpoint) is the fact that to the Hermetics the jewelry trade owes its origin.

Commencing with the talisman, a rare stone or piece of ore, or metal, of peculiar feature, to be carried by the owner for protection from evils, seen and unseen, men (not women) went forth, firm in the faith that they were supported by mystic powers, to fight the battle of prehistoric life. But, if to be carried, how much easier to be worn. And with the talisman mounted for wear we have an amulet. But still it was the revered portable property of stern man. And when, in later history, the amulet of mystic powers received that adornment in metal mounting and framing that made of it a decoration, as well as talisman, to adorn the finger, the wrist, the arm, or

the leg, then first could the fetiches be classed as jewels.

Now, in occult wisdom and the philosophy of the mystics none but the Rosicrucians appear to have arrived at conclusive discoveries. To them alone is ascribed perfection of knowledge of such arcana as the philosophers' stone, the transmutation of the baser to the precious metals, the absolute power over the prolongation of life, and the art of healing therein included. Therefore, to these Hermetic brethren we can look with absolute confidence for any really reliable information as to the actual and relative merits innate in the different stones and metals and their method of manipulation into effective amulets. And they do not disappoint us, for we have a long line of mystic lore revealed to us that will aid a jewelry factory to stock a retail store with a numerous and choice selection of charms that will either invoke the aid of the ethereal spirits, both good and evil, or fend off malign incantations.

And to assist the jeweler to carry out in his alchemistic workshop the elaboration of talismanic adornments that shall enable their wearers to "entrance" the surrounding spirits—human, divine and demoniac—the following recipes and devices are respectfully dedicated:

ROSIKRUCIAN MYSTIC RINGS.

In the Londesborough Collection is the original of a Cabalistic ring, a cut of which accompanies these lines. Outwardly it gives no appearance out of the ordinary. The outside loop is set with a ruby and an amethyst. Pressure upon these stones opens a spring and the two outer bands spring apart, displaying numerous cabalistic signs as well as the names of the following spirits, whose powers the talisman conjures: "Asmodiel, Nachiel, Zamiel." No doubt this pretty bit of workmanship was the product of a German, probably formerly apprenticed to a goldsmith. It dates from about the end of the 15th century, hence one may conclude it to have been made by or for and worn by a mystic philosopher at the time when Johannes Faustus and his many fellow-students were devotees to the occult.

Another talismanic ring (Fig. 2), illustrated herewith, is in base metal, gold plated, and dates back to the 14th century. No doubt it did great marvels in its day, but its powers got "worked out," for nothing of a peculiar character appears to its wearer in these days.

Fortunately for the jeweler genius who is desirous of following in the footsteps of the gold and silver smiths of the 13th to the 15th centuries as to the design and workmanship of talisman mounting, some specific instructions have been handed down from generation to generation, which are still available. The following should prove of interest:

Set in a ring of silver, the combined figure of a ram on half the body of an ox will immediately

reconcile to the wearer any person or thing with which it comes in contact.

The form of a woman with her lower extremities shaped as a fish, if described as holding a mirror and a branch, will, when cut on a "marine hyacinth" (pale sapphire), and set in a gold ring, procure for the wearer any reasonable or unreasonable desire. First, however, the signet design should be covered with wax.

Over the head of a man behind his plow draw the hand of the Lord making a sign; include with this a star. These mystic symbols cut on any stone (they must however be worn "in all purity") will secure safety from tempest and immunity to crops from storms.

In green jasper cut the form of a head and neck. Set the stone in a brass or iron ring on which are engraved the following mystic letters, "B. B. P. P. N. E. N. A." Wear this and thou shalt in nowise perish, but be preserved from many diseases, especially fever and dropsy, it will also bring the wearer good luck in "fowling." Be "reasonable in all things and in battle as well as in lawsuits thou shalt be victor."

Cut the following design on a *diadochus* (diacardius): A tall, erect man holding in one hand a *patra* (Roman libation plate or shallow vessel), and a serpent in the other. The sun must appear over his head and a lion at his feet. Set this in a leaden ring. To work enchantment with this mystic symbol you must place wormwood and fenureek underneath it; then carry it to the river's banks and call up any evil spirit you desire, and he must answer all the questions put to him.

Cut on a white hyacinth (pale sapphire) a youth with crowned head sitting on a four-legged throne. Supporting the throne must be a man (standing) under each leg holding it up with his neck; a circle must surround the neck of the seated figure and his hands must be raised to heaven. This effective device should be mounted on a ring of silver, and the ring should be exactly the same weight as the stone. To increase the sphere of usefulness of the charm produce an impression of the device in

+THEBAIG VTHGLVTHANI



FIG. 2—TALISMANIC RING AND INSCRIPTION, XIV. CENTURY.

a wax composed of mastic and turpentine. This seal can be used by your friends, and if worn about the neck will produce the same charm as the ring itself, namely: "It will obtain from king, noble or wise man whatsoever is requested. But the wearer must go with pure mind and chastity."

Cut in Carnelian the form of a man, bearded, and holding a flower in his hand. Set this in a ring of tin. The ring must be made on the change of the moon and it must be a Friday, the first or eighth of the month. Armed with the powers of such a ring any person touched with it must forthwith do as you wish him.

All the spirits of darkness must obey the wearer of a leaden or iron ring with a man standing on a dragon and holding a sword set in it; to him they will reveal "in low-toned song the location of hidden treasures and the course of procedure necessary in unearthing the same."

"Engrave on iron pyrites the effigy of a man on horseback. In one hand the bridle and in the other a bow. Gird him with a sword, and set in a ring of gold." This will render a man "invincible in battle." Steep the ring in oil of musk and anoint the face with the musk, and "none can resist you but all who see will fear you."

Another talismanic method of becoming invincible in battle (and presumably in more modern prevailing frays of life) is to set in an iron ring a man in armor standing erect with drawn sword, and on his head a helmet. Here again, however, the

LOUIS KAHN

MOSES KAHN

SAMUEL H. LEVY

L. & M. Kahn & Co.

Importers and Cutters of
DIAMONDS

170 Broadway, cor. Maiden Lane, New York

AMSTERDAM: 2 TULP STRAAT

CUTTING WORKS: 29 GOLD STREET

Arnstein Bros. & Co.

Importers and Cutters of

DIAMONDS

65 Nassau Street

New York

LONDON: Audrey House, Ely Place

AMSTERDAM: 6 Tulp Straat

ALBERT LORSCH.

N. Y. Telephone Call, 2161-2 John.

ALFRED KROWER

ALBERT LORSCH & CO.

LORSCH BUILDING, 37 and 39 MAIDEN LANE, NEW YORK

131 Washington Street, Providence, R. I.

Rose Diamonds

stone on which the engraving appears must be of absolutely the same weight as the ring in which it is set.

"Thou shalt not be harmed in purse or person by thine enemies" if you wear a silver ring in which is set Capricorn on a garnet. Judges cannot pass false judgment on you and you will do an "abounding" business, for you will gain the honor and friendship of many and all enchantments against you will prove futile.

PLANETARY RULINGS.

Infinitesimal powers were lodged in the Rosicrucians through their depth of astral knowledge. In reading the planetary affinities they were, indeed, mystic adepts. And their astrological rings doubtless were more perfect and practical in their working than any built on modern lines. Our exceedingly limited scientific knowledge of the "chemic" action of planetary bodies on the telluric sphere, in these days of astrological fallacies, does not permit the jeweler to plan the hermetic ring off-hand. He must follow closely the ritual and readings laid down by those occultists.

The Planetary rings of the astrologers



FIG. 3—ASTROLOGICAL RING.

were designed according to the different planets to which they were assigned. Thus for the sun there was a diamond or a sapphire in a golden circle; for the moon crystals were mounted in silver; for Mercury magnetic iron was sent in mercury (of course the mercury had to be in an amalgam, such as with lead); for Venus the methyst was mounted in copper; for Mars iron-mounted emeralds; for Jupiter carnelian was set in tin; for Saturn the turquoise was mounted in lead.

In the accompanying cut of an astrological ring will be noticed on the signet the sun centrally located, the moon and stars beneath her and Mars at her side, while at the side of the ring a rough drawing of corpio is seen.

The undoubted power of precious stones ruling over the destinies of a planetary governed race of humanity makes it manifest that the following astrological rulings should guide our daily intercourse.

Golden jewelry and yellow gems are appropriated for Sunday's use, inasmuch as they carry with them on that day most propitious conditions. They are also active agents against all the antagonistic influences of the spirit realm on the day governed by our supreme orb—the sun.

On Mondays adorn your person with all the pearls and white stones in your collection of jewels (but no diamonds!), because this day comes under the rule of Nature's second potentiality—the moon.

Decorate yourself on Tuesday with all the fiery hued precious stones you can (honestly) lay your hands on, especially rubies. For it is the day of Mars, and lustrous fire

Imports of Clocks, Watches, Jewelry and Gems Into Canada.

TORONTO, Can., Feb. 19.—The monthly report of the Department of Trade and Commerce of Canada for November gives the value of imports for home consumption in the jewelry and kindred trades as follows:

	Month of November,		Eight months ended November,	
	1906.	1907.	1906.	1907.
Clocks:				
Great Britain.....	\$2,961	\$1,420	\$10,612	\$13,082
United States.....	35,579	29,730	197,953	203,408
Germany.....	4,569	2,726	32,670	38,981
Other countries.....	490	2,046	11,650	12,837
Totals.....	\$43,599	\$35,922	\$252,885	\$268,308
Watches:				
Great Britain.....	\$2,879	\$1,546	\$18,866	\$16,993
United States.....	87,218	74,739	510,502	563,609
France.....	4,365	341	17,979	3,501
Switzerland.....	25,700	17,950	107,456	146,490
Other countries.....	4,921	3,892	26,227	35,518
Totals.....	\$125,083	\$98,468	\$681,030	\$766,111
Jewelry:				
Great Britain.....	\$27,165	\$16,920	\$112,923	\$162,362
United States.....	116,531	83,774	545,982	548,471
Germany.....	7,371	9,185	77,948	84,922
Other countries.....	2,264	6,600	28,070	73,278
Totals.....	\$153,331	\$116,479	\$764,923	\$869,033
Gold and silver and manufactures of:				
Great Britain.....	\$23,804	\$25,719	\$183,841	\$179,519
United States.....	54,775	40,526	212,244	207,321
Other countries.....	4,042	4,579	56,622	46,819
Totals.....	\$82,621	\$70,824	\$452,707	\$433,659
Precious stones of all kinds and imitations of (dutiable):				
Great Britain.....	\$3,141	\$79	\$21,415	\$58,385
United States.....	3,630	5,659	28,518	54,233
France.....	3,727	2,940	21,838	60,024
Holland.....	676
Other countries.....	1,327	1,494	7,892	30,924
Totals.....	\$11,825	\$10,172	\$79,663	\$204,242
Precious stones of all kinds and imitations of (free):				
Great Britain.....	\$13,065	\$6,428	\$486,407	\$555,605
United States.....	14,759	5,374	102,951	188,479
France.....	3,425	778	122,714	258,421
Holland.....	52,630	8,925	218,694	289,548
Other countries.....	6,434	223	129,910	36,479
Totals.....	\$90,313	\$21,728	\$1,060,676	\$1,328,532

stones are her particular "cinch," as latter-day mortals term "affinities."

Trot out all your turquoise, sapphires and every stone that attempts to rival the cerulean tones of heaven's undimmed canopy each Wednesday morning with religious regularity, because those "blues" belong there, and not to Monday, as some weak mortals think.

There is a special occult call for a plentiful display of amethysts and "deep-colored stones of sanguine tint" each Thursday. For it is the day dedicated to Thor—"the Runic impersonated Male Divine Sacrifice" (whatever that may be).

On Friday—specially presided over by Venus—you can best propitiate that goddess by hiding your personality, so far as your means permit, behind emeralds. But if you happen to run short of emeralds any Friday you can to some extent cover up your deficiencies with green stones (malachite is big and cheap, for instance). For although Aphrodite's appropriate color is the imperial, yet she is said by adepts to have certain "leanings" towards the sinister green at times.

But Saturday is the day of days (half holiday, too, for some!), then you can glitter resplendent in diamonds. They have special talismanic powers on the day of Saturn, and must spread their "luster-dart-

ing" rays all around you on that day, even should the dark cavernous depths of Uncle William's safe hide their glory throughout the rest of the week.

(Continued in the issue of March 11.)

Contracts for Watches, Clocks, Etc., Awarded by Navy Department.

WASHINGTON, D. C., Feb. 19.—The Navy Department has awarded the following contracts:

For 12 comparing watches, Harris & Schaffer Co., Washington, \$180.

For 18 boat clocks, Chelsea Clock Co., Boston, Mass., \$247.50.

For 12 binoculars, Price & Keen, Philadelphia, Pa., \$283.20.

J. J. Keegan and H. J. Rosencrantz, the Asiatic travelers, known as "The Irishman and the Jew," attended the Philadelphia Jewelers' Club banquet, after having accomplished a trip which covered over 160,000 miles throughout the Orient, including India, Australia, New Zealand and the far east China. These two gentlemen represented the Keystone and Philadelphia Watch Case companies, the D. F. Briggs Co., Bay State Optical Co., Reed & Barton, Esser & Co. and several other American concerns.

EDUARD VAN DAM

CUTTER OF

DIAMONDS

— CUTTING SHOPS: —

ANTWERP

41 Rue de la Province (Sud.)

CABLE ADDRESS, MADNAV

NEW YORK

437-439 Fifth Ave.
Cor. 39th St. Knabe Bldg.

TELEPHONE 5879 38TH ST.
CABLE ADDRESS DEVRIVAN

AMSTERDAM

55 Ruysdaelstraat

CABLE ADDRESS, MADNAV

LONDON OFFICE, 22 Holborn Viaduct

THE HERMAN KECK MANUFACTURING CO.

CUTTERS OF

DIAMONDS

19-21 WEST FOURTH STREET

CINCINNATI, OHIO

AMSTERDAM

2 Tulpstraat

LONDON

40 Holborn Viaduct

OPPENHEIMER BROS. & VEITH.

CUTTERS OF DIAMONDS.

Cutting Works
43-45-47 John Street

NEW YORK
65 Nassau Street

MEYEROWITZ
BROS

MEYEROWITZ BROS.

IMPORTERS OF

DIAMONDS

PRECIOUS and
SEMI-PRECIOUS STONES

ESTABLISHED 1896

NEW YORK: 37-39 Maiden Lane
PARIS: 58 rue de Maubeuge
AMSTERDAM: 2 Tulpstraat

MEYEROWITZ
BROS

Mr. Brown Knows Nothing.

Examination in the Bankruptcy of Jos. Brown & Co. Continues at Chicago.

CHICAGO, Feb. 21.—The examination into affairs of Jos. Brown & Co. goes merrily. If it were not for the seriousness of the matter which involves an estate with liabilities of over \$175,000, the tiffs between learned counsel engaged, the sphinx-like silence of Jos. Brown himself and the ludicrous remarks sometimes elicited from witnesses the sessions might be very enjoyable from a vaudeville standpoint.

Three sessions were held last week. George Ebner, one of Brown's bookkeepers, testified that great efforts had recently been made to collect outstanding accounts and that a five per cent. bonus was offered as a premium for prompt remittances. Mr. Ebner showed by the ledger that there was \$2,000 outstanding at the present time, of which he considered \$5,000 was bad. As

Glick, another bookkeeper, had testified on Jan. 1 there were outstanding claims \$75,000, there is a modest shrinkage of \$5,000 if both are right.

Jacob Ringer, of Ringer, Wilhartz & Co., representing the receivers, has announced that the pass book of Jos. Brown & Co. cannot be found, although he has conducted a diligent search to be made for it. Brown smiles serenely during the examination. In fact, he almost laughed when he was asked where the pass book was. He said it was among the rest of the books.

I. S. Daniels, formerly manager and credit agent for Jos. Brown & Co., testified he only knew about the debit side of the ledger and that he got all his figures from the bookkeeper. Asked where he got his figures from in the statement made to the Board of Directors last June, Mr. Daniels said the stock was "estimated" and that no figures were given to verify it. One thing Mr. Daniels said he didn't like, and that was that sometimes when a customer failed, instead of charging the amount to profit and loss the bookkeeper under Mr. Brown's instructions would open an account with a mercantile agency and debit the agency with the amount lost. This, of course, would be listed as an asset in statements to the creditors. During the examination it was further stated that some of the employes of Jos. Brown & Co. had been robbing him of considerable merchandise.

Ben Roth testified that the stock on which he loaned \$2,000 was worth between \$4,000 and \$5,000. Mr. Roth banks at the Continental National Bank. S. M. Jess, a former stockholder, got \$10,000 worth of goods on which he loaned \$5,000. The goods are in storage and the warehouse receipt was indorsed to him the day before the petition in bankruptcy was filed. Mr. Jess banks at the Continental National Bank.

Jos. Brown & Co., banked at the Continental National Bank, and Ben. S. Mayer, assistant cashier of the Continental National Bank, is a director in the corporation Jos. Brown & Co.

Jess testified that he got \$37,000 worth of stock, putting in \$15,000 cash and pledges, making his actual payment \$27,000, and took out about the same amount in cash, notes and the store at 344 State St., which is a corporation owned. He said he was

with Brown for about a year and that when he went with him in 1904 Brown owed only between \$15,000 and \$20,000.

Brown testified he didn't know anything at all, except that just before the petition was filed he sold lots of goods to Ben Roth at a special price. Also to Flower on State St. He didn't know what the special price was. He didn't know much about a load of goods sent to 1900 W. Polk St. He knew they went to that address, but didn't know what place of business was at that address. He suggested that Attorney Ringer send some one there and find out. Likewise he didn't know about a load of goods shipped via the "Big Four" Railroad and another load shipped via the L. S. & M. S. a few days before the petition was filed.

Mr. Brown couldn't explain his transactions with the Continental National Bank, nor why he borrowed \$2,000 on a demand note on Feb. 4 and paid the bank \$7,000 on the same day. His answer was, "I must have been crazy." The notes he paid were not due. When questioned about his diamond record book which has disappeared, Mr. Brown said he didn't know anything about it.

Nathan S. Gordon, teamster, testified as to the carting done for Jos. Brown & Co.

Emil Noel, formerly in charge of the diamond stock, said that only he and Mr. Brown had access to the diamond safe. The diamond records, he said, were kept in a black book, and each article was numbered. A separate diamond account acting as a check on the black book was kept on a card system in a special cabinet. This also cannot be found.

Mr. Noel said there were always in stock while he was there between \$6,000 to \$10,000 worth of diamonds and about \$3,000 to \$4,000 out on memorandum. Attorney Ringer stated the entire value of the diamonds found in the safe was between \$300 and \$400. Israel Shrimski, representing various diamond claims, asked if Brown hadn't bought diamonds heavily in December, but the witness couldn't say as he was not in the store that month.

The last meeting was held last Friday. Miss Berger testified to the existence of the diamond records, and said there was between \$20,000 and \$25,000 worth of diamonds always on hand. She checked the stock at the end of November.

The discount clerk at the bank testified that Brown paid the notes before they were due of his own volition. Ben Roth testified that he bought \$3,900 worth of goods at a discount, Jan. 30, \$944 on Feb. 3, for which he paid \$643, and \$679 worth on Feb. 5, for which he paid \$492. He explained the difference between the last two bills and the payments therefor by claiming Brown was indebted to him for the difference.

Attorneys representing the creditors are Messrs. Ringer, Shrimski, Friedman, Walsh and Eastman.

Hugo Pam, representing the bankrupts, is seeking to effect a settlement at 25 cents on the dollar. 15 cents cash and 10 cents on notes, secured by the outstanding accounts.

Creditors seem to think that if Brown can raise \$25,000 cash necessary and pay 15 cents he might have raised that amount before he failed and tided his affairs over. In fact, no creditor seen so far by THE CIRCULAR-

WEEKLY reporter is satisfied with the affairs of this estate. Brown's utter lack of memory regarding his affairs does not seem compatible with the close attention which he was known to pay to the details of his business.

Schedules of Horowitz Bros., New York, Filed in the Bankruptcy Court.

Schedules in bankruptcy of Horowitz Bros., 196 Canal St., New York, against whom a petition in involuntary bankruptcy was filed in January, were filed in the United States District Court last Friday. They show liabilities of \$42,909, and nominal assets of \$26,371.32, consisting of stock, \$12,000; debts due on open account, \$13,456; money in banks, \$9.37.

Among the unsecured creditors named in the schedules are A. Strauss & Co., \$629; Dieckerhoff, Raffloer & Co., \$250; Wm. Demuth & Co., \$127; B. Illfelder & Co., \$443; A. Kastor & Bro., \$315; Porter Bros. & Co., \$134; E. Faber, \$112; M. Kasnowitz, \$138; American Safety Razor Co., \$256; J. Busch, \$450; L. Engel & Co., \$150; Bates Bros. Co., \$369; Fr. Bergner & Co., \$169; J. A. Jerauld, \$290; Geo. Borgfeldt & Co., \$489; International Silver Co., \$436; F. M. & J. L. Cobb, \$558; Cory & Reynolds Co., \$313; Donley & Co., \$274; R. B. McDonald Co., \$213; E. S. McLaughlin & Co., \$177; W. A. Sturdy Mfg. Co., \$789; W. H. Wilmarth & Co., \$102; Marden & Kettlety Co., \$266; Schofield, Battey & Co., \$105; Standard Button Co., \$140; Standard Chain Co., \$118; Waite, Mathewson & Co., \$118; Whitestone Jewelry Co., \$143; Workman & Newman, \$134; Knickerbocker Watch Co., \$187; P. & A. Linton Co., \$107; Alfred Burke & Co., \$294; S. & B. Lederer Co., \$663; McRae & Keeler, \$166; C. R. Harris, \$175; Ettliger Mfg. Co., \$144; Electric Chain Co., \$733; American Optical Co., \$353; S. Langsdorf & Co., \$300; Philadelphia Watch Case Co., \$725; Chas. Parker Co., \$106; W. A. Rogers, Ltd., \$174; Schwab Mfg. Co., \$114; J. Rogers Silver Co., \$185; Fr. Speidel, \$129; Sussfeld, Lorsch & Co., \$493; C. H. Selick, \$108; Louis Barnett, \$425; L. Goldberg, \$159; Chambers Printing Co., \$140; Billboard Publishing Co., \$225; Buyer & Index Co., \$150; E. E. Vreeland, \$136; Holmes Electric Protection Co., \$113; Attleboro Chain Co., \$242; Esser & Co., \$220; Fontneau & Cook Co., \$1,123; Metropolitan Garter Co., \$551; Attleboro Mfg. Co., \$302; Bloom & Mandell, \$489; W. C. Horn & Bro., \$252; Morgan Jewelry Co., \$420; American Silver Co., \$204; Spencer Optical Co., \$106; Adolphe Schwob, \$1,721; Watson, Porter, Giles & Co., \$517; Ross, Saltman & Anderson, \$128; Lyons Mfg. Co., \$157; A. A. Landau, \$113; Geo. L. Brown & Co., \$372; Tuttle & Stark, \$195; Freeman, Daughaday Co., \$316; North American Watch Co., \$700; O. E. Weidlich & Co., \$244; Strauss Bros. & Co., \$420; J. Leibowitz, \$137; Joseph Kaplan, \$600; Bornstein Bros., \$200; Saul Horowitz, \$400; Max Rothberg, \$400; B. Fechter, \$100; Joseph Keller, \$5,260; Fourteenth St. Bank, \$750; and Chas. S. Horowitz, \$6,000, who indorsed paper of the bankrupts.

P. W. Ellis & Co., Toronto and Montreal, have issued judgment against E. Champagne, St. Clothilde, P. Q., for \$142.

To show our absolute confidence in the stability of the prices of Diamonds we will add to all bills purchased from us, from this date on, the following guarantee:

If at maturity of this bill the market prices are less than those charged for the above goods, we guarantee to refund the difference between the then existing market prices and the prices charged on this bill.

CYRUS PRICE & COMPANY
NEW YORK

Annual Convention of the Indiana Retail Jewelers' Association Held at Indianapolis Proves a Great Success.

INDIANAPOLIS, Ind., Feb. 20.—An attendance of about half the members, good-fellowship, considerable business of importance and absolute harmony on all questions discussed marked the first annual meeting of the Indiana Retail Jewelers' Association, which was held here on Tuesday and Wednesday. The sessions were held in the auditorium at the Claypool Hotel, C. Z. Rowe, president.

The convention, which was the first since the meeting for organization held last August, was devoted chiefly to business. There were few papers and no banquet, but every minute of the schedule during the two days was occupied. While the attendance might seem small, the association is less than one year old, and when organized had only 17 charter members. The roll now numbers 98 members, with good prospects for a large increase before the next session.

In addition to affiliating with the Amer-

ican National Retail Jewelers' Association, plans were discussed for fighting jobbers who sell at retail, and a movement was started for establishing an annual watchmakers' school.

There is considerable bitterness between the association and jobbers who do a retail business, and such jobbers were censured in no mild terms in President Rowe's address and on the convention floor. Protests were also made against the methods of jobbers and manufacturers that sell to mail order houses and certain instalment houses. A spirit was manifested to oppose such concerns as forcibly as possible.



FIRST VICE-PRESIDENT H. H. BISHOP.

At the opening session J. P. Mullally, a local dealer, and president of the Indianapolis Retail Jewelers' Association, delivered an address of welcome, after having been introduced by President Rowe. His address was brief, but he told the members that the city was theirs. He explained the small attendance by saying that a ma-

majority of dealers could not get away because they had only one other person in the store with them, and to leave would require closing their stores part of the time. Mr. Mullally deplored the fact that a large number of association members have a wrong conception of the purpose of organization. Many had an idea that organization meant direct pecuniary profit to them, and after making a complaint or two of alleged wrongs, dropped out of the association.

President Rowe's annual address brought forth considerable applause, especially when



C. Z. ROWE, PRESIDENT.

he touched on the necessity of improving conditions in the watchmakers' craft. Among other things he suggested that a law be passed that would provide a State Board of Examiners, as a protection to the trade and the public.

So-called cut-throat methods, sometimes employed by dealers, were mentioned in the course of the address and a number of specific instances where jobbers had sold at retail were given. In order to overcome such objectionable features President Rowe suggested stronger efforts to build up the retail organization so that it would have a power.

Following an executive session at which similar questions were discussed, Ralph M. Clark, Anderson, president of the Indiana Retail Merchants' Association, gave an interesting talk on the parcels post and the benefits of organization. Mr. Clark is a retail jeweler, and thoroughly understood the situation confronting other members of the association.

The Indiana Retail Merchants' Association was cited as an example of what it was possible to accomplish by banding together. This association, within a few years, has grown from a small beginning to about 12,000 members, and is one of the most influential in the country.

Speaking of parcels post, Mr. Clark said

only two things could result—a greater postal deficit and increased taxation. Mail order houses, he said, would be the only ones to gain anything of value from it. It was suggested that each member of the association send a letter of protest to his congressman, and this will be done.

At the night session watchmakers and other employes of local jewelers were invited to hear the two addresses of the evening. One of these, "How to Detect and Remedy Errors in the Lever Escapement," was by H. C. Higgenbotham, superintendent of the South Bend Watch Co. The other was on scientific salesmanship, and was by Dr. C. B. Morrell, of the Sheldon Correspondence School, Chicago.

Mr. Higgenbotham's address was along strictly technical lines and was of much benefit to watchmakers. The lecture on salesmanship was also very thorough, explaining the effective methods of showing the best point in the goods and the best way to handle the customer.

At the session Wednesday morning, Secretary J. A. Oswald brought up the proposition to hold a technical school for watchmakers in Indianapolis one week each year.



SECOND VICE-PRESIDENT A. ROTHERMEL.

Such a school would be open to all watchmakers, whether members of the association or not, and the officers were instructed to see what could be done along such lines. It was suggested that the different watch factories might be willing to send experts as instructors at such a school for the benefits to be derived in having watches repaired correctly.

Charles F. Artes, Evansville, proposed that the association affiliate with the national association as a body, and after some discussion this step was taken with a unanimous vote. While a number of members were individually members of the national association, it was believed more good could be accomplished if the Indiana society joined as a body.

Later in the day Mr. Artes proposed that some token of appreciation be given to Secretary Oswald, and although the blushing secretary insisted that all he had done was done gladly and for the good of the order,

Not One Stone

has ever come near attaining the popularity of the Reconstructed Ruby—the Hope Sapphire following next. * * * Comparatively inexpensive, these two Gems are within the reach of all, their demand increasing rapidly with their introduction to the general public.

* * * We have realized that these Scientific Gems are articles that have come to stay, and have accordingly equipped ourselves for their uninterrupted production. Our facilities for cutting these stones enable us to fill all possible orders without delay.

L. Heller & Son

Importers of Precious and Imitation Stones
68 NASSAU STREET, NEW YORK

PARIS
39 Rue de Chateaudun

PROVIDENCE
212 Union Street

IDAR
14 Hauptstrasse

ORDER

DIAMONDS

ON MEMORANDUM FROM

ALFRED H. SMITH & CO.

London,
3 Holborn Viaduct.

170 BROADWAY, NEW YORK
Corner Malden Lane.
Also 475 FIFTH AVENUE

Chicago,
103 State Street.

— P E N D A N T S —

Our Spring line of 14 Kt. Baroque Pearl and Colored Stone Pendants is very complete both in design and price, the latter ranging from \$2.00 up.

CROSSMAN COMPANY

3 MAIDEN LANE : : : : : NEW YORK

A. ROSEMAN, 9-11-13 Maiden Lane, New York

IMPORTER OF

DIAMONDS

Maker of Diamond Jewelry



TRADE-MARK.

Established 1872

HEADQUARTERS FOR

AMERICAN WATCHES

Ⓜ When A Ⓜ
Customer Wishes
To Sell

YOU any lot or single piece of mounted diamond jewelry—large or small—do not turn him down absolutely, send the goods to me for a

SPOT CASH OFFER

and save all trouble and worry. I pay all express charges and insure the goods in transit. I have been in the business right here for 16 years, and can give the very best references as to responsibility on application. Offers and valuations furnished promptly. Write for further information.

J. J. COHEN
1011 Chestnut St.

Ⓜ Philadelphia, Pa. Ⓜ
Established 1891

committee was appointed to get something for him. Just before adjournment, President Rowe handed Mr. Oswald a gold watch set with a diamond, and the A. P. Craft Co. offered to furnish the necessary description without cost.

All of the old officers were re-elected unanimously. J. P. Mullally, Indianapolis, was nominated for president but withdrew, saying that as the association had been organized only a few months, the officers who had done the hard work should be re-elected.

When the president and vice-president had been re-elected, J. H. Reed, Indianapolis, suggested that the re-election be made unanimous all the way through.

Considerable fun prevailed when it was discovered that Mr. Reed held an elective office as a member of the executive committee. He was innocent, however, as he thought he held an appointive office. No one was lost on installing ceremonies, and



SECRETARY J. A. OSWALD.

President Rowe declared everyone was installed and business continued.

At next year's meeting the by-laws will be amended so that the annual dues can be increased from \$1 to \$2 a year, to cover the dues in the national association. In the future, annual meetings will be held the third Tuesday in February, so that they can follow the annual meeting of the Indiana State Optical Society. This will enable the members of the latter society to meet with the jewelers, if they so desire.

As a result of the meeting just closed, it is probable that the coming legislature will be asked to establish a State Examining Board of watchmakers. According to the association there are many irresponsible watchmakers in the State who should be eliminated. With such a board and with an annual watchmakers' school, it is believed that the watchmaking trade will be greatly improved.

The roster showed the following members present:

Z. Rowe, Argos; A. Rothermel, Connersville; H. Bishop, Indianapolis; G. C. De Camp, Shiraz; J. A. Oswald, Crawfordsville; E. M. Wilhite, Danville; J. B. Hesselbrock, Liberty; J. H. Arnold, Columbus; J. E. Porter, Loogootee; Samuel

Beauchamp, Fairmount; Isaac Booth, Tipton; J. H. Reed, Indianapolis; Asher W. Gray, Indianapolis; H. Vollmer, Princeton; J. H. Noyes, Osgood; J. P. Mullally, Indianapolis; C. H. Mergel, Brazil; O. C. De Selms, Attica; Chas. F. Artes, Evansville; T. N. Sykes, Shelbyville; D. O. Williams, Odon; William E. Eldridge, Boswell; A. M. Keck, Odon; J. M. Bigwood, Terre Haute; J. D. Taylor, Logansport; H. J. Hoffman, Loogootee; Joseph Myers, Brookston; Frank Hazeltine, Kokomo; C. K. McCain, Kokomo; Ralph B. Clark, Anderson; J. M. Washburn, Anderson; George S. Kern, Indianapolis; E. B. Edmonds, Bluffton, and P. M. Tindolph, Vincennes.

The officers of the association are: C. Z. Rowe, Argos, president; H. H. Bishop, Indianapolis, first vice-president; A. Rothermel, Connersville, second vice-president; J. A. Oswald, Crawfordsville, secretary; and J. H. Arnold, Columbus, treasurer.

The executive committee consists of: J. H. Reed and H. H. Bishop, Indianapolis; J. B. Hesselbrock, Liberty; J. E. Porter, Loogootee, and E. M. Wilhite, Danville.

Creditors of Max Schucht, Milwaukee, Wis., Who Recently Filed a Petition in Bankruptcy.

MILWAUKEE, Wis., Feb. 21. — Max Schucht, 1512 Vliet St., this city, who, as announced in last week's issue of THE CIRCULAR-WEEKLY, has filed a voluntary petition in bankruptcy in the federal court, claims assets of \$14,221. The liabilities are given as \$13,490.

Word came to the directorate of the Milwaukee Jewelers' Club last month that Schucht had been buying large quantities of goods and selling them at haphazard prices, in order to dispose of them quickly. The matter was taken up by the Milwaukee Jewelers' Club, and a protest was made to Schucht against the cutting of prices, especially in so flagrant a manner. Then the club adopted strong resolutions condemning Schucht's business methods.

Schucht about two months ago made a proposition to his creditors to settle at 50 cents on the dollar. Creditors refused this offer. The club's action was followed by the Wisconsin Retail Jewelers' Association, which framed up like resolutions and both were sent to the Jewelers Board of Trade in New York for action. Finally Schucht filed the voluntary petition in bankruptcy. The creditors for \$150 and upward are as follows: Chas. F. Hilgendorf (note), \$400; L. Gutmann & Sons, \$1,691; Henry Freund & Bro., \$3,344; L. Longsdorf & Co., \$146; Bradly Ring Mfg. Co., \$926; A. Wittnauer Co., \$207; Waterbury Clock Co., \$105; Kreiss & Hubbard, \$213; H. Heinrich, \$149; William Seckels, \$654; S. D. Champlin Co., \$175; Ansonia Clock Co., \$274; Calumet Watch Co., \$300; Heyman & Kremer, \$275; W. J. Rosenfeld, \$668; New Haven Clock Co., \$140; American Cuckoo Clock Co., \$216; White Art Co., \$138; Illinois Watch Co., \$111; Chas. Kolb & Co., \$457; A. Hirsch & Co., \$487; M. A. Mead & Co., \$1,076; Rogers Silver Plate Co., \$191; H. F. Hahn & Co., \$400; R. Wallace & Sons Mfg. Co., \$569.

James Polk, president of the Second National Bank, Jackson, Tenn., who recently purchased the stock of Taliaferro Bros. for \$8,540, has sold it to I. L. Grady, a jeweler of Jackson, who will place it on sale at that place in a short time.

Pittsburg Jewelers Escape With Little Damage from Effects of Recent Floods.

PITTSBURG, Pa., Feb. 21.—Another big flood has come and gone, but fortunately did not do serious damage. Merchants had time to prepare for it and took no chances. The waters reached a stage of almost 31 feet and caused many dealers much annoyance. Heeren Bros. & Co., at Penn Ave. and 8th St., had from five to six feet of water in their cellar, and naturally some damage was done, but not to amount to much, because everything of value was removed to places of safety. S. & B. C. Weinhaus, just across the street from Heeren Bros. & Co., had the same amount of water in their cellar, but nothing was damaged.

Over on the North Side the stores in lower Federal St., nearest to the river, were somewhat affected by the high tide.



TREASURER J. H. ARNOLD.

The worst that was done, however, was to leave a large deposit of mud on the floors of the stores. Fortunately the highest stage held sway on Sunday, when there is no business, and the flood tide did not come upon the city until late Saturday night, so that business was not interfered with materially. The water was not as high by five feet, as it was in March last year, when so much damage was done. The rivers ran full of ice during the present flood, but the ice, which was two and three feet thick, kept to the middle of the streams and caused no damage to buildings.

The floods which have visited Pittsburg during the last few years are a source of much anxiety among the business men, and already the city is being prevailed upon to do something to prevent the flooding of the streets in the low districts.

In the towns of Turtle Creek, Tarentum and elsewhere, and especially in the upper Ohio river towns, situated in the low lands, much damage is reported, but jewelers fortunately will not be among the chief sufferers.

REGISTERED



TRADE-MARK

AMETHYST JEWELRY

REGISTERED



TRADE-MARK

We have many beautiful and striking pieces in amethysts and combinations of amethysts and pearls, and amethysts and diamonds.

The popularity of amethyst jewelry makes this exceptionally salable stock, and you should certainly have a few representative pieces.

We carry Rings, Necklaces, Brooches, Scarf Pins and La Valliere.

If you have our catalog, well and good—If you haven't, send for it.

REGISTERED



TRADE-MARK

HAYDEN W. WHEELER & CO., Importers
2 Maiden Lane, NEW YORK, N. Y.

AMSTERDAM, 2 Tulp Straat

Phone 7365 Cortland

LONDON, 50 Holborn Viaduct

REGISTERED



TRADE-MARK

F. A. JEANNE

Seal Sapphires

5 Square de l'Opera

PARIS, FRANCE

Cable Address

“GEMFINDER”

Western Union Code

STERN BROS. & CO.,

CUTTERS OF

DIAMONDS,

CUTTING WORKS:

138-142 West 14th St., N. Y.

68 Nassau St.,

NEW YORK.

CHICAGO,
103 State Street.

LONDON,
29 Ely Place.

TURQUOISE

Matrix - Turquoise

Best the World Produces

WE ARE prepared to furnish to the trade Matrix - Turquoise in all shapes and sizes.

Exquisite Color and Markings

We cut Turquoise to order

Mines at Mojave County, Arizona

THE ARIZONA
TURQUOISE MINES CO., Inc.

Cutting Works and Sales Office

171 Broadway, New York

SEND FOR CATALOG

Telephone 5728 Cortlandt

TRY US ON
DIAMONDS

Lissauer & Company
IMPORTERS

52-54 MAIDEN LANE, NEW YORK

Gems and Precious Stones

Cloth, Postpaid, \$1.00. Published by The Jewelers' Circular Pub. Co., 11 John St., New York.

Cincinnati Diamond Broker Brutally Assaulted by Man Who Tried to Rob Him.

CINCINNATI, O., Feb. 24.—Leonidas E. McClymon, a piano and diamond broker at 40 Main St., was the victim of a most cowardly attack, Feb. 20, by a thief, who brutally beat him in an attempt to rob him. The thief was unsuccessful, but escaped.

McClymon had advertised that he had some diamond goods for sale, and a short time thereafter a well-dressed young man appeared, saying he had seen the advertisement. He seemed to gain favor with the broker, and called several times, finally making an appointment to come and make a selection Thursday, at about noon. In the meantime the broker secured about \$500 worth of goods on memorandum from Richter & Phillips in order to be sure and please his customer.

At the appointed time the young man called, but McClymon became a little suspicious and was about to put his goods away when the stranger suddenly pulled a bludgeon from his overcoat pocket and struck the broker several blows over the head.

As soon as the broker appeared to become unconscious the thief tried to take a diamond ring from the latter's finger, but Mr. McClymon roused himself and began to fight his assailant. The broker, despite his 60 years, has great strength, and though bleeding from several bad wounds was successful in warding off further attacks of the robber, who was soon glad to give up the fight and make his escape without getting any booty.

Mr. McClymon then staggered to a nearby drug store, where his wounds were dressed. The police were then notified. The thief is described as a man of about 25 or 30 years old, about five feet eight inches in height and weighing 175 pounds. He wore a black overcoat, black suit and a black derby hat.

As yet the police have not caught the thief.

Girl Gets Verdict Against Cincinnati Jeweler for False Arrest Though He Denies He Accused Her.

CINCINNATI, O., Feb. 19.—The damage suit for \$2,500, brought by a Miss Carroll against Edward Simper, a Vine St. jeweler, which has been pending for the last four years, came up for trial Feb. 16. A judgment of \$500 was granted the plaintiff against Simper, who then gave a notice of appeal.

About four years ago a girl about 18 years of age called at Mr. Simper's store and asked to see some rings. Mr. Simper waited on her, but failed to suit her. As he was about to leave he noticed a ring worth \$12 was gone, and mentioned the fact to the girl, who made a request that she be searched. Mr. Simper says he didn't wish any search made as he did not see her take the ring nor had he accused her.

However, Miss Carrall telephoned to a girl friend, asking her to come and stay with her. After the arrival of the latter, Miss Carroll insisted on being searched, and was supported in it by her friend, according to the report. Upon this, Mr. Simper says, he notified police headquarters, and in a short time two detectives arrived,

and the two girls very cheerfully went to the house of detention, where search was made of both girls, but nothing was found. Miss Carroll immediately brought suit for \$2,500 damages.

Since the trial the matron who made the search says she can testify to remarks made by the girls which will probably throw considerable additional light on the case if a new trial is had. She says she kept away from the last trial as she did not doubt that the case would be dismissed.

The local Retail Jewelers' Association is taking much interest in the case and will bring it up at the next meeting, when steps will be taken toward beginning action for the protection of jewelers against such proceedings in the future.

Bids Received and Contracts Awarded by Government to Supply Various Articles.

WASHINGTON, D. C., Feb. 19.—The Bureau of Supplies and Accounts, Navy Department, has received the following proposals:

On a quantity of silver plated ware for the Brooklyn Navy Yard, International Silver Co., Meriden, Conn., \$3,343.63.

On 480 thermometers, Brooklyn Navy Yard: Henry J. Green, Brooklyn, \$696; Holman & Maurer Mfg. Co., New York, \$180; A. E. Moeller, Brooklyn, \$640.80; Philadelphia Thermometer Co., Philadelphia, Pa., \$452.40; Queen & Co., Philadelphia, Pa., \$591.60; Chas. F. Taglibue Mfg. Co., New York, \$672; Vermilye & Power, New York, \$960.

WASHINGTON, D. C., Feb. 21.—The award for silver-plated table ware for the Brooklyn Navy Yard, for which bids were opened on Feb. 8, has been made to the only bidder, the International Silver Co., Meriden, Conn., at \$1,877.30.

WASHINGTON, D. C., Feb. 22.—The Bureau of Supplies and Accounts, Navy Department, has received the following proposals:

For 50 boat and deck clocks, Chelsea Clock Co., Boston, Mass., \$687.50.

For 30 spyglasses, Bausch & Lomb Optical Co., Rochester, \$420; Price & Keen, Philadelphia, \$444; Sussfeld, Lorsch & Co., Philadelphia, \$526.50; Keuffel & Esser Co., Hoboken, N. J., \$585.

For 50 spyglasses, Bausch & Lomb Optical Co., \$420; Price & Keen, \$417.50; Sussfeld, Lorsch & Co., \$422.50; Keuffel & Esser Co., \$595.

For 100 thermometers, Henry J. Green, Brooklyn, \$145; Manning, Maxwell & Moore, New York City, \$146.50; A. E. Moeller, Brooklyn (a), \$129, (b) \$98; Philadelphia Thermometer Co., \$95; C. J. Tagliabue Mfg. Co., \$132.50.

For 100 binoculars, Bausch & Lomb Optical Co., \$2,350; Price & Keen, \$2,360; Sussfeld, Lorsch & Co., \$2,487.50.

For 20 binoculars, Bausch & Lomb Optical Co., \$1,060; E. Lietz Co., San Francisco, \$1,020; Sussfeld, Lorsch & Co., \$1,140.

Mrs. F. L. Ellis, Ensley, Ala., has moved into attractively furnished quarters on Ave. E., at that place. The premises have been entirely renovated for her use.

Thieves Smash New Orleans Jeweler's Window, Steal Rings Worth \$15,000 and Escape.

NEW ORLEANS, La., Feb. 20.—What the police say is the most daring as well as one of the largest robberies ever perpetrated in this city, occurred shortly before noon yesterday at the establishment of M. Waldhorn & Co., dealers in antiques, diamonds, watches, silverware, etc., 327 Royal St. In broad daylight, in sight of hundreds of people two thieves smashed the window of the store, picked up about \$15,000 worth of rings displayed therein, and drove off in a buggy, scaring away pursuers at the point of their revolvers.

According to Mr. Waldhorn's statement it was shortly after 11.30 when the men drove up in a buggy. Stopping directly in front of the windows, in which the concern displays its diamonds, one of the robbers alighted, and with a small Belgian block, which he carried wrapped in a manila paper and swung on a leather blanket strap, he deliberately smashed the plate glass of the window. Reaching in the robber grabbed two trays of diamond rings, jumped into the buggy and drove away.

Mr. Waldhorn, who was behind the counter at the time, though dazed for a moment at the audacity of the thief, rushed out quickly and tried to prevent the escape of the men by grabbing the bridle of the horses. The thieves, however, quickly leveled their revolvers at his head and he was forced to let go, though he started in pursuit. Further down the street others hearing the jeweler's cry, rushed out to capture the men, but the revolvers of the thieves compelled them to retreat.

There were no policemen in sight at the time, and many of the people who joined in the case not hearing the cry of "thief" thought it was simply a run-away horse.

Mr. Waldhorn, who was near enough to the thieves to give a description of them, said that the man who smashed the glass was quite tall, well dressed in dark clothes, had a dark complexion and was about 28 years old. The other man in the buggy was short and stout and appeared to be much younger than his companion.

The buggy used by the two men was later driven up to the jewelry store by two negroes, who said they had been given 50 cents to return it to the stable. The negroes were arrested, but were too frightened to give a description of the parties from whom they had received the vehicle.

Mr. Waldhorn, who is a member of the Jewelers' Security Alliance, immediately wired that organization to have Pinkerton detectives put upon the case and also notified the Pinkerton agency in this city. Detectives and police are now at work. Waldhorn & Co. have offered a reward of \$1,000 for the recovery of the stolen articles.

Mrs. Mary Satz, Springfield, Mass., who succeeded to the business of her husband, the late Paul Satz, is compromising with her creditors at 20 cents on the dollar.

Knute Ruthstrom, a jeweler of Ontonagon, Mich., was recently found dead in bed at his home, at that place, having been suffocated by smoke which issued from a fire, the origin of which is unknown.

JEWELERS' CLUB, PHILADELPHIA



R. A. G. R. A. E. F.

Thirteenth Annual Banquet.

Saturday Evening, February 22, 1908,

at the

Bellevue-Stratford Hotel.



PHILADELPHIA, Pa., Feb. 24.—To half a thousand members of the Philadelphia Jewelers' Club and their guests, including many men famed as lawyers, statesmen, politicians and captains of industry, the number 13 served, for once at least, to be anything but unlucky when the hospitable organization gave its 13th annual dinner at the Bellevue-Stratford Hotel in this city Saturday night, the anniversary of the birth of George Washington. There are none to gainsay the fact that the banquet was the most successful ever given by the club. Not only were the postprandial orators more than usually eloquent, but the attendance was bigger than in past years.

Even though for years the prodigality of the entertainments annually given by the Philadelphia Jewelers' Club has been famous, those who were there Saturday night are sure that the club outdid itself on the occasion of its 13th banquet. The Bellevue-Stratford's magnificent ballroom needed little decoration, but it was made most attractive with potted plants, exotics and cut flowers. Throughout the evening an orchestra played the popular songs of the hour and songs which are this club's only. After the feast of good things was over and orators had eloquently told of the achievements of the first President of the United States, of the greatness of the country at present, of the projects for its expansion and here and there told some good stories, almost all the guests went to the club house, where the members and their friends fraternized as only jewelers do when the hands of time are figuratively stopped and all are once again boys, "if only for the night."

The dinner had been planned this year with exceptional care, Col. J. Warner Hutchins, of Governor Stuart's staff and one of the most active jewelers in the country, is credited, together with L. P. White, William H. Long, A. G. Lee, Joseph Cadwallader, Archie Rutherford and Henry Bodenheimer, with having made the banquet better than any other ever given by the club. As president of the club Colonel Hutchins presided at a long table from

which diverged 11 other tables, where were seated the club members and their guests.

At the guests' table were: Mayor John E. Reyburn, former Mayor Charles F. Warwick (an old friend of the Jewelers' Club), Congressman J. Hampton Moore, who has



COL. J. WARNER HUTCHINS,
President of the Philadelphia Jewelers' Club.

come especially into prominence as the advocate of the project to make an inland waterway system paralleling the Atlantic seaboard; Col. John L. Sheppard, Congressman J. H. Small, of North Carolina; Hon. John Barrett, Hon. J. E. Ransdell, Louisiana; Congressman Henry C. Loudenslager, of New Jersey; the Rev. David Steele, a prominent and eloquent clergyman of Philadelphia; A. B. Millar, secretary of Governor Stuart of Pennsylvania; M. N. Smith, president of the Boston Jewelers' Club, and Leo Wormser, president of the New York Jewelers Board of Trade.

While the invited guests, all of whom made postprandial addresses which were

eagerly listened to and who for the most part decried the "hard times" cry and extolled the virtues of President Roosevelt, making comparisons with Roosevelt and Washington, there were seated less conspicuously at the other tables men who are widely known not only as jewelers and members of the Jewelers' Club, but as men of influence and distinction. The guests came not alone from the Middle Atlantic States, but from the south and the west and from the big manufacturing centers of the east.

On the whole it was one of the most representative gatherings of jewelers and their friends which has perhaps ever been held in the country, and President Hutchins had only one regret to express, and this was that Harry C. Larter, president of the Jewelers' 24-Karat Club of New York, was unable to attend on account of illness. Col. Hutchins read a telegram from Mr. Larter after making a brief opening address, in which he referred happily to the fact that the Philadelphia Jewelers' Club was holding its 13th annual banquet, but that this fact should not be taken as ill omened, since the club was at the same time observing the 15th anniversary of its birth. He regarded it as auspicious that the club should be privileged to observe its anniversary on such an occasion as the celebration of the birth of the country's first president.

Colonel Hutchins pointed with justifiable pride to the menus laid at each guest's plate, which told succinctly of the organization and yearly progress of the Jewelers' Club. The menus this year were made not simply to be a guide to the material things which were to be enjoyed for the night only, but as lasting keepsakes of the 13th annual dinner. The cover was tastefully adorned with an etching of a peacock, and on the inner cover an engraving of the American eagle, with outstretched wing and in an expectant, eager, defiant attitude, poised on a rock upon which was engraved the numbers "1908." Then a replica of the charter of the Jewelers' Club was contained in the menu, together with photographs of the interior of the club house on Chestnut

St., near 13th St., and a general history of the club, with a brief but interesting reminiscences of the banquets of past years and the honored guests on those occasions, many of whom have since gone to the bourne from which no traveler ever returns. In the envelope inclosing the souvenir menu was included a table chart, so that there would be no excuse for a guest becoming lost or not being able to know where to find a friend, and an embossed card with each guest's name and the menu.

While the guests repaired to the banquet hall about seven o'clock it was two hours later before the speechmaking was begun. In the meantime the menu was being discussed with avidity, which must have made the chef's mouth water himself as he witnessed the relish with which the banqueters made away with his gastronomic preparations and washed it all down from the succulent bivalve, Delaware shad, duck, terrapin, etc., etc., to "plombiere glace Praline" with good old Amontillado sherry, Sauternes, Pommery Sec., and mineral waters (if you insisted upon it).

THE MENU.

Grape Fruit.
Martinis.
Puree Washington.
Amontillado Sherry.
Salted Almonds. Pecans. Relishes.
Planked Shad With Roe.
Sauternes.
Potato Balls.
Mallard Duck.
Pommery Sec.
Green Peas. Fried Hominy.
Tansan.
Jewelers' Club Punch.
Cigarettes.
Terrapin, Philadelphia Style.
Head Lettuce Salad.
Camembert and Roquefort Cheese.
Toasted Crackers.
Plombiere Glace Praline.
Cigars.
Croquants.
Coffee.

After Colonel Hutchins, as toastmaster, had welcomed the guests, spoken of the loyalty of the members of the Board of Directors to the club, who, he said, were deserving of all the credit for making the 13th annual dinner the most successful one ever given by the club, and had referred facetiously to the 24-Karat Club's emulation of the Philadelphia Jewelers' Club, he spoke of the fact that the club was able to give a big dinner and entertain its guests and still have left \$11,000 in its treasury. "This," he said, "is due to the splendid manner in which your house committee and board of governors devote themselves to the interest of our club. But I am not going to talk much shop," concluded Colonel Hutchins, "I simply want to say, though, that after you have heard from the distinguished men at my right and at my left, we want you all to come down to the club, and if you are afraid of missing services to-morrow, why just remember that we have with us to-night as our guest a clergyman, and we may attend his services here and excuse ourselves if we are late to-morrow."

President Hutchins then proposed a toast to the President of the United States. This was drunk with a display of great enthusiasm. Hurrahs were given with spirit, and the guests waved handkerchiefs and napkins as national refrains were sung. Colonel Hutchins then introduced former Mayor Charles F. Warwick, once the bright

shining light at all meetings and gatherings of the Jewelers' Club, but for three years an ill man. He attended the dinner on crutches, the first appearance he has made at a social gathering since the 10th annual meeting of the Jewelers' Club. Mr. Warwick made a characteristic address, introduced with this quotation:

"Home again, home again,

From a distant shore;

And oh, it fills my heart with joy

To see my friends once more."

"Every week during my illness there came to my bedside a bouquet of flowers, fresh with the fragrance of your love. All during that time I prayed to God that I might meet you once more and thank you for your friendship. You cannot imagine how deeply I feel that my prayer has been heard. It has been three years since last I have been out," facetiously ended Mr. Warwick, "and if that is not a long time between drinks then the camel is not in my class."

Mayor Reyburn was introduced and made an interesting speech, which was roundly applauded. Throughout the dinner the Mayor was signaled out for distinction by a host of old friends. When he was called upon for a speech he was more than ordinarily hearty and sincere in extending the freedom of the city to all visitors, and assuring them of protection so far as it might be in the power of a city authority to do so. The Mayor spoke good naturedly of the progress of the country, and declared that if so many jewelers should be able to assemble on an occasion of this sort that it was sufficient evidence that times could not be as bad as some financiers would have the people believe.

Hon. Joseph E. Ransdell, of Louisiana, and president of the National Rivers and Harbors Congress, spoke largely of the project for deeper inland waterways, saying that it was one of the most important subjects before the Congress of the United States to-day. Said he: "In the city of Philadelphia, where so many of the great events in the career of the immortal Washington were enacted and which is more interested to-day in the improvement of its harbor and outlet to the sea than any other great city in the Union, it seems eminently proper when celebrating the memory of our national hero and father to recall his connection with the subjects of waterways. Indeed, this subject is of vital importance to the whole American people. Transportation is the very soul of trade."

John Barrett, director of the International Bureau of American Republics, made an interesting speech, comprehending a number of projects for the expansion of the United States as a commercial power. In part he said:

MR. BARRETT'S ADDRESS.

Although the subject may not seem to concern directly the jewelers of this country, I desire to take advantage of a banquet being held in Philadelphia and having present a considerable number of its representative men, to point out the vital importance of improving the rivers and harbors of the United States, like those of the Delaware River, so that our country may be in a position to develop its foreign commerce in competition with the rest of the world. In most earnest terms I wish to emphasize that it will be folly to expend \$300,000,000 on the construction of the Panama Canal unless we expend a similar amount on the rivers and harbors of our coast line so that we can take full advantage of the canal when it is opened.

Every country of importance is spending vast sums of money to develop its internal waterways and its coast harbors so that its business interests can secure their share of the commerce that is carried upon the high seas. This is true not only of Europe, but of Asia and South America. Inasmuch as the Latin-American republics are the particular field with which I have to do, I want to bring home to you the wonderful work which is being done down there and which, in a sense, shames the United States and proves that we are behindhand, comparatively speaking, in the competition with our own sister republics.

It will probably surprise you to learn that to-day river and harbor improvements are in process of construction in Latin-American countries which, when completed, will represent an expenditure of \$175,000,000. If other works recently completed and others which are contemplated or are sure of being started in the near future were included, the total would be nearly \$300,000,000.

A few illustrations of what is being done will show to you that the progressive Latin-American republics understand the importance of having good rivers and harbors. Rio Janeiro, the beautiful capital of Brazil, which has a population of 900,000, is now expending over \$25,000,000 in providing itself with a system of concrete docks and wharfs that will rival those of any European port. Buenos Ayres, the great capital of Argentina, has now expended over \$50,000,000 in securing one of the finest harbors on both continents, and is about to expend \$25,000,000 more in enlarging these facilities so that the greatest ships that navigate the seas can come up to her wharfs.

And so I might go on enumerating scores of other public works of this character, but this will suffice to support my argument that, if the representative Latin-American countries are spending millions at this time on their waterways and harbors, the United States should do likewise and should put Philadelphia on a basis of equality with such South American ports as Rio Janeiro, Buenos Ayres and Valparaiso.

In impressing upon the men here to-night what a field of trade is open to them in Latin-America—for the same opportunity exists there for building up a market for the jewelry trade that there is for other lines of business—let me call your attention to the fact that the total foreign trade of Latin-America last year, exports and imports, amounted to over \$2,000,000,000, or one-third of the total foreign trade of the western hemisphere. Taking a specific example of the possibilities of these nations, let us bear in mind the wonderful record of the Argentine Republic. Last year this progressive, enterprising nation, in a southern temperate climate, conducted a foreign trade amounting to nearly \$600,000,000. The republic of Brazil, which, by the way, covers a larger area than the United States proper, conducted a foreign commerce of \$430,000,000.

The greatest forward movement that the world has ever witnessed, outside of the United States, in general material development, will be seen in Latin-America during the next decade. It is surely high time that the manufacturers and exporters of the United States made themselves familiar with its possibilities and gained their share of the commerce before it is too late, in the competition with the nations of Europe. Let Philadelphia awaken to her special opportunity and enrich herself accordingly.

Congressman Loudenslager, J. Hampton Moore and Joseph E. Ransdell spoke, and it was exactly midnight before the speechmaking was ended and the jewelers and their friends as well as the guests of honor accepting the cordial invitation of the president of the Jewelers' Club carefully pocketed their souvenir menus and, in jovial groups, wended their way to the club rooms, only about a block away, where the rest of the evening, or more accurately where early morning, was spent in a manner which showed that good fellowship prevailed. Here L. P. White, Colonel Hutchins, Joseph Cadwallader, William Linker, Del. Lee, Henry Bodenheimer and a host of others made the hours pass pleasantly. Fred Yockel was again in demand and made the hit of the evening with a new song. Even Mayor Reyburn was so delighted with the cordiality of the members of the club and so

Chester Billings & Son

1840

Successors to
Kandel, Barmore & Billings

1908

Importers of Diamonds
Other Precious Stones, and
Pearls, Diamond Jewelry

1840, Kandel & Barmore; 1866, Kandel, Barmore & Co.; 1880, Kandel, Barmore & Billings; 1897, Chester Billings & Son

New York, 58 Nassau Street, 29 Maiden Lane
London: 22 Holborn Viaduct, E. C. Paris: 53 Rue de Chateaudun
Amsterdam: 2 Tulp Straat

GEORGE H. HODENPYL.

WALTER N. WALKER.

HODENPYL & WALKER

IMPORTERS OF

DIAMONDS

OTHER PRECIOUS STONES
AND PEARLS

MANUFACTURERS OF
FINE DIAMOND JEWELRY

373 FIFTH AVENUE, NEW YORK

Corner 35th Street

Telephone, 5093 Madison Square

CHAS. F. WOOD & CO.

DIAMONDS

1 MAIDEN LANE

NEW YORK

EISENMANN BROS.

IMPORTERS OF

Pearls and Precious Stones

452 Fifth Avenue, New York
cor. 40th St., Knox Building

3 Rue St. Georges, Paris.

much entertained that he tarried until after one o'clock. Only the old reliable steward is to be depended upon to report all that happened in the club rooms between midnight and Sunday morning. But he declares "He sure ain't got nothin' to say."

The Members and Guests.

Speakers' Table.—A. B. Miller, private secretary of Governor Stewart; Congressman H. C. Loudenslager, New Jersey; Hon. J. E. Ransdell, North Carolina; Hon. J. Hampton Moore, Pennsylvania; Hon. J. H. Small, Mayor John E. Reyburn, Philadelphia, Pa.; President J. Warner Hutchins, Hon. John Barrett, Former Mayor Charles F. Warwick, Rev. David M. Steele, Leo Wormser, president of the Jewelers' Board of Trade.

Table A.—Fred. Barry, B. W. Musselman, John B. Baxter, Charles Mortimore, T. Benton Dornan, John Mallory, J. E. Cadwallader, Fred. Yockel, H. E. Stevenson, Harry Krug, Horace Draper, Clayton Ruff, W. F. Reimold, A. Strouse, Jacob Binder, Jr., A. H. Fox, L. H. Eisenlohr, E. L. Weil, W. W. Wood, Dr. W. D. Robinson, Dr. W. J. O'Brien, J. McClintock, Jr., Samuel Collins, E. W. Marland, J. B. Leifried, J. T. Alburger, F. J. Dougherty, Charles Sapp, L. J. McGrath, W. I. Irwin, John Brant, F. C. Michaelsen, Julius Vetterlein, L. F. Müller, M. C. Myers, J. Howard Sheeler, W. R. L. Fullerton, Clyde G. Allan, R. C. Green, Jr., J. G. Humes, Dr. H. C. Deaver, John J. Campbell.

Table B.—W. H. Kinna, L. P. White, M. P. Hoffman, I. B. Elliott, N. D. Gibbs, Victor Binder, A. S. Smith, J. S. Wheeler, F. W. Schuler, A. J. LeJambre, Sydney Moulthrop, F. C. Bode, J. P. Maas, H. D. Stevens, F. H. Miller, R. Unger, L. B. Hall, W. C. Penfold, L. H. Carpenter, W. H. Iszard, Harry B. Sommer, S. S. White, S. R. Weaver, C. B. Churchill, R. L. Coates, Arthur Sellers, William Sutton, W. G. Earle, A. K. Sloan, A. G. Lee, William H. Platt, J. N. Montgomery, C. L. Beckley, L. V. Benson, L. F. Ellmore, F. J. Foster, E. Unger, A. L. Wilson, J. B. Wood, W. T. Purnell, Frank Hurlburt, F. B. Hurlburt.

Table C.—H. Bodenheimer, S. K. Zook, Hon. D. O. Watkins, C. S. Powell, R. T. Ferguson, J. Fromme, L. P. Rutherford, H. Brown, J. S. Strayer, F. F. Gibson, F. R. Krugler, W. H. Thompson, Jr., Thomas Moore, A. H. Kirkpatrick, W. R. Eisenhower, Fred. Keim, J. C. Adler, F. S. Reid, George A. Briggs, W. C. Nellis, DeForest Ely, Edgar Smith, Charles Muth, F. Alcott, F. A. Robbins, C. Bedichimer, Sig. Myers, A. Rutherford, W. Smock, C. B. Webster, Charles Rudolph, W. T. Benson, W. S. Moore, J. D. Beacham, F. R. Hollister, A. W. Teele, S. E. Bolles, J. A. Goewry, O. J. Scheer, F. Hotz, R. G. Monroe, R. B. Steele, William E. Wood.

Table D.—Charles S. Cook, Benj. F. Griscom, Charles S. Cook, Jr., Walter B. Scott, Ernest Petry, N. B. Eltinge, A. J. Sherrard, Frank I. Locklin, John J. Moffitt, Harry Schlarb, Carl H. Lebkuecher, W. Mayhew, V. L. Burgesser, Wm. T. Gilpin, John T. White, Harry Peck, H. F. Bucher, R. C. Putnam, E. B. Midlen, C. W. Chatterton, George W. Long, George W. Read, H. M. Larter, P. L. V. Thicry, Charles M. Beck, Sr., Fred M. Knowles, Albert F. Carter, R. H. Schley, William Reiman, John D. Battin, George F. Henris, S. Frank Pierson, Josiah Clift, Hon. J. A. Lebkuecher, E. H. Eckfeldt, H. C. Novioch, R. M. Pile, Alfred Reeves, John T. Howard, Fred Bloch, Horace B. Pearson, A. F. Perpignan, William H. Long.

Table E.—John T. Windrim, Col. L. E. Beiter, Col. J. R. Wiggins, I. Langsdorf, Otto Eisenlohr, George E. Walton, W. Groverman, T. J. Mooney, W. T. Gough, F. S. Feraille, C. Weaver, A. Alexander, Jr., Jack Townsend, Joseph Weaver, J. W. Pepper, H. H. Kinberg, Elwood M. Williams, Charles McKaig, A. E. Allsopp, M. Wisham, Dr. T. Reading, J. Clifford Wilson, W. H. Myers, A. C. Yard, G. W. Edmonds, C. C. A. Baldi, A. P. Swoyer, C. J. Eisenlohr, T. K. Ober, W. T. Carter, F. Stanbrough, Richard Gough, Harry Smith, C. H. Conant, F. R. Comstock, Thomas Allsopp, H. Starr Richardson, George E. Hoffman, G. F. Hoffman, M. McDonald, Thomas Massey, Charles de Bourbon, Adolph Gosling.

Table F.—J. Albert Caldwell, Edward Holbrook, J. Frederick Thomas, J. E. Alexander, F. Spies, Charles A. Atkins, M. Stratton, John D. Reynolds, Jr., J. V. Lashhorn, C. S. Douglas, Wm. P. Sackett, Joseph F. Dean, Samuel Levy, L. H. Nordlinger, Frank Kind, Harry Lissauer, Robert B. Allan, T. Allan Power, J. McGill Walker, Chas.

Power, Wm. D. LeRoy, John S. Hoolbrook, William Linker, Hiram A. Bliss, H. H. Hamilton, Crane, H. Higham, F. H. Buhler, Samuelquette, W. L. Washbourne, J. A. Herschede, C. Hodges, J. D. Pettingill, Dr. A. W. Rosenbach, Joseph W. Leberman, M. Leberman, E. S. Stout, N. Zimmilton, W. G. Blair, H. A. Crawford, Thomas G. Jones, H. E. Jeffery.

Table G.—T. Zurbrugg, C. G. Alford, G. W. Ribner, L. M. Levy, H. Eliassoff, S. M. Hynein, A. Schwob, B. F. Wentz, A. W. Moyer, M. Davis, A. Buecke, W. Allison, E. R. Crippin, D. Ewing, F. Feussner, W. W. Finley, B. Levy, Schierloh, John Graham, A. Judis, C. M. Fogg, H. Pool, J. T. Montgomery, J. L. Shepherd, W. Alford, J. H. Gaskill, B. Thorpe, G. Budd, H. Small, F. W. Trewin, H. B. Stanger, C. F. Inck, J. G. Mueller, J. J. Keegan, J. F. Easley, J. Rosencranz, F. B. Falkner, F. H. Kain.

Table H.—John A. Lehman, J. B. McClung, A. Stehhead, John H. Kessler, R. M. Sheain, C. T. Hugherty, F. C. Osmer, G. M. Hallenbeck, F. H. Chapman, T. B. McGinley, C. H. Strunk, G. L. Wood, George Davis, Frank Lane, Gus Mayer, P. Sauer, Charles Hickman, Charles I. Sauer, S. Douglas, Jr., H. O. Brown, C. B. Barton, E. Edwards, H. C. Howell, B. C. Warnick, W. Coleman, W. K. Thudium, G. B. Summerfield, S. McVey, Frank Schanz, F. H. Burpee, W. O. Manze, M. F. Schmidt, E. C. Schmidheiser, George Rieger, J. W. Gosch, T. O. Nock, Harry Reger, F. L. Breitinger, A. Lincoln Acker, D. V. Town, W. H. Podesta, A. V. Brown.

Table I.—David B. Provan, R. S. Medary, C. P. Wy, John A. Smyth, G. E. Donaldson, Charles Ganich, W. W. Fulmer, George W. Kranich, George Beardsley, F. E. Delano, F. W. Rauch, John L. Warner, E. R. Hunt, J. Allis, Leon Goodman, John Van Dusen, Charles C. Leighton, Geo. Fletcher, James S. Benn, John T. Custis, Lester Ilman, of THE JEWELERS' CIRCULAR-WEEKLY; J. Caruth, W. M. Perrine, C. K. Taylor, M. L. Nickel, H. N. Tuttle, H. A. Shute, H. J. Neebe, J. Braun, W. J. Tighe, S. B. Kent, C. Glander, John W. Edmondson, William McMahon, E. M. Edgar, John Ober, E. C. Hammond, J. Craig, C. Wanamaker, William Long, A. B. Bailey, J. Denn.

Death of Thomas E. Bruner.

RALEIGH, N. C., Feb. 21.—Thomas E. Bruner, for 21 years secretary of the State Department of Agriculture, a noted mineralogist, and one of the most popular officials in the service of North Carolina, died at his home in E. Jones St., Raleigh, N. C., Sunday morning. He was 50 years old and a native of Salisbury. Mr. Bruner's name had long been associated with the work of making North Carolina gems known to the world.

Twenty-one years ago he became associated with the State Department of Agriculture and greatly increased the State's resources and advantages. He arranged exhibits at world's fairs, and the North Carolina Exhibit at the Columbian Exposition at Chicago, attracting widespread interest, his collection of North Carolina gems being the most complete and perfect existence. A booklet exploiting North Carolina resources and possibilities, written and illustrated by Mr. Bruner, was translated into German and Norwegian, and upon his visit to Europe this and other information about his native State attractively displayed was distributed throughout England, Scotland and Germany.

At the recent meeting of the State Board of Agriculture resolutions of regret were adopted unanimously. He is spoken of as a man who showed an unbounded interest in the welfare of his native State, and one who was always willing and ready to furnish information of value to those interested in the gems produced in his native State. He was sent to Boston to install the mineral exhibit of North Caro-

lina at that exposition and afterward had charge of important work at New Orleans, Chicago, Atlanta and St. Louis.

The funeral was held from the First Presbyterian Church, of which the deceased was a member. Surviving him are his widow, three sons and three sisters.

Louisville Jewelers Too Smart to be Fooled by Tricks of a Clever Swindler.

LOUISVILLE, Ky., Feb. 21.—A young man, who was arrested in this city and has now been taken to New Orleans, La., is believed to be a clever swindler, and though he did not succeed in getting much from the jewelry trade here, as far as is known, this was due to the diligence of the merchants and not to any lack of effort on his part. The man who gave his name as Thomas E. Halley, had a good scheme, which, had he been successful, would have resulted in the loss of many thousands of dollars to jewelers in this city.

About Feb. 10, the man called at the store

the jewelry be delivered to the young lady, as he had promised it to her that night. Saying that he would be around in the morning, he left the store. Needless to say the jewelry was not delivered, and the matter was reported to the police.

It was later learned that the same man had called upon J. K. Lemon & Son, and gone through the same procedure, ordering a large bill to be sent to the same address he had given to Rodgers & Krull. He is also said to have obtained a diamond ring from a pawnbroker named Stephens. Mr. Lemon refused to deliver the goods, as did Rodgers & Krull.

The man was later arrested and the police learned that he was wanted in New Orleans on the charge of passing a check for \$160. The detectives who came to Louisville from New Orleans to bring him to that city, said that his name was Grant Armstrong.

The jewelers here believe that the man's game was to have the jewelry delivered to the young lady whose name he gave, then tell her they were not the goods that were



THOS. E. HALLEY, ARRESTED IN LOUISVILLE, KY.

of Rodgers & Krull, Fourth Ave. and Green St., and asked to see some diamonds, saying he wished to spend about \$1,500. He selected a brooch valued at \$400, a pair of screw earrings valued at \$600, and a solitaire ring valued at \$425, a total of \$1,425, saying the goods were for his intended bride. He gave to the jewelry firm the name and address of the young lady, and said that he would call the next day and pay for the articles, but that in the meantime the jewelers could send them to his intended on approval.

When references were asked, Halley referred the concern to the Seelbach Hotel, where he was stopping and also to the Third National Bank, where he had an account. Mr. Rodgers called at the bank and learned that the man had given the institution a draft on New Orleans for \$5,000, that the draft had been sent for collection, but that no report could be had on it for at least five days.

The next day the young man called, as he said he would, and presented a check for \$1,425, but Rodgers & Krull asked that he have it certified before delivering the diamonds. The man said he would like to do this, but it was after banking hours. As he was about to leave the city, he asked that

ordered and get them from her on the plea that he wished to return them to the jewelers. She is not believed to be a party of his scheme in anyway.

Jewelers' Gold Bars Withdrawn and Exchanged at New York.

Week Ended Feb. 21, 1908.

The U. S. Assay Office reports:
Gold bars exchanged for gold coin.....\$236,609.76
Gold bars paid depositors..... 43,552.06

Total	\$280,161.82
Of this the gold bars exchanged for gold coin are reported as follows:	
Feb. 17.....	\$26,031.34
" 18.....	82,065.37
" 19.....	81,901.34
" 20.....	31,229.24
" 21.....	15,382.47
Total	\$236,609.76

The store of Heinley & Bro., Colorado Springs, Colo., has been sold to I. V. Barnes, formerly of Holly, Colo. The store will be conducted under the direction of the new owner.

F. C. Haase, Mason City, Ia., will move April 1, from 106 S. Main St., into more commodious quarters, where he will also have show windows which allow him to display his goods to better advantage.

ADDISON W. WOODHULL, President.
FRANK K. HUFF, Vice-President.

GILBERT T. WOODHULL, Treasurer.
WILLIAM J. McQUILLIN, Secretary.

MOUNT & WOODHULL,

IMPORTERS OF

**DIAMONDS,
OTHER PRECIOUS STONES,
PEARLS, ETC.**

MAKERS OF

**FINE
DIAMOND
JEWELRY.**

26 Maiden Lane,
(Southwest Corner Nassau Street)

NEW YORK

**EMERALDS, DIAMONDS
AND PEARLS**

**CABLE ADDRESS:
MILBAGG**

BAGG, PERINE & CO.
IMPORTERS
452 FIFTH AVENUE, at 40th Street
(Formerly at 21 MAIDEN LANE)
NEW YORK

**TELEPHONE
NUMBERS:
917-918 BRYANT**

**RUBIES AND
SAPPHIRES**

Pearl Necklaces and Collarettes.

**Mounted
Diamond
Jewelry**

of every
description.



*Leading Swiss
Jewelry
Emil Knopf
John W. Ruefer
Frank L. Wood.*

**Largest
assortment
of all kinds of
very fine, fancy
and rare gems,
including Pearls,
Diamonds, Rubies,
Emeralds and Sapphires.**

**Particularly Fancy
Colored and Fancy
Shaped Diamonds.**

182 & 184 BROADWAY
NEW YORK

Death of George Deuble.

CANTON, O., Feb. 23.—George Deuble, one of the city's most prominent and influential citizens, as well as one of its pioneer jewelers, passed away Saturday at residence, 438 N. Market St., after an illness of several months. The funeral services will be held at the family home to-day at 2 p. m., and will be conducted by the Rev. T. J. Bucher, of this city, and Rev. E. Willard, of Akron.

Mr. Deuble, who is 74 years old, lived practically all his life in Canton, having come here with his parents when an infant. His father, George Deuble, was practically the first jeweler of this city, having started in business in 1833, at the site of the present Deuble residence. The death of the latter, the two sons, Martin and the deceased took charge of the business and moved it to its present location, 130 S. Market St. Martin Deuble died many years ago and since that time George Deuble continued alone. For 60 years he was connected with the jewelry trade, 40 years of that time he was at the present location. At the time of his death he was one of the oldest merchants of the city.

Mr. Deuble was married Sept. 22, 1858, to Miss Caroline Herbruck, and with her celebrated their golden wedding five months ago. He is survived by his widow, three sons, Walter H., Horace and Homer, and two daughters, Laura and Alice.

Mr. Deuble was a great lover of music and was for many years organist of the German Reformed Church, and a director of the Concordia Singing Society; for years he was an elder of the Trinity Reformed Church. He was also prominent in the Masonic fraternity. In the jewelry trade he stood high, both for his technical and business ability and was respected and honored for his many sterling qualities. He leaves a host of friends in business and social life who deeply mourn his death.

Government Discontinues Suits Against Byron L. Strasburger & Co. Over Duties Claimed on Imported Watches.

It was learned this week that the Government has discontinued its suits brought last October against Byron L. Strasburger & Co., 56 Maiden Lane, New York, for recovery of duties and penalties claimed to be due because of alleged undervaluation of Swiss watch cases. Under the terms of settlement the defendant pays to the government \$30,000, this settling in full all claims and also paying \$10,000 in penalties.

The particulars as to the cases brought by the government were published in THE JEWELERS' CIRCULAR of Oct. 16 and 17, 1907. It will be remembered that the importers brought in movements in cases. No charge was made that the invoice was not correct, as to the combined value of cases and movements. It was claimed, however, that in the given instances, the value of the movements was excessive and that of the cases was too little, and that as a result, the government lost duties, because the rate for movements is 25 per cent ad valorem and for cases 40 per cent.

The Letzler-Lorch Co. has been incorporated in Louisville, Ky.

Important Pearl Case Argued.

Proceedings by Bernard Citroen to Recover Additional Duties Paid on Leeds' Pearls Heard by the United States Circuit Court.

The suit of Bernard Citroen, Paris, against the United States Government, an action brought to recover \$110,000, part of duties collected by the Government on 37 pearls, brought to New York in June, 1906, by the plaintiff and sold to Mrs. Wm. B. Leeds, was tried Monday before Judge Lacombe in the United States Circuit Court at New York. The judge consented to hear the case because he had presided at similar cases which had been carried to the United States Court of Appeals.

J. Osgood Nichols appeared as Assistant United States Attorney for the Government, and W. Wickham Smith for the importer. The particulars of the importation have been published a number of times in his journal. Mr. Citroen, when he brought the pearls to New York, had them invoiced at \$220,000, and paid a duty of 10 per cent. ad valorem under the clause of the tariff law relating to pearls in their natural condition. Soon afterward the Government claimed that it had information leading to the conclusion that the pearls really constituted a necklace and hence that they were dutiable at 60 per cent. as jewelry, instead of 10 per cent. A reliquidation was ordered and Mr. Citroen was called upon to pay 50 per cent. more duty, amounting to \$110,000. It is for the return of this additional duty that he brought his action.

Mr. Citroen's protest was first held before the Board of General Appraisers, which decided in his favor by a vote of two to one. The testimony taken before the Board was presented to Justice Lacombe, together with the additional testimony.

The Government laid special stress on testimony which it obtained, since the hearing before the Board, from Mrs. Wm. B. Leeds, the owner of the necklace. Her testimony was taken Feb. 6, at her home, 987 Fifth Ave., New York, before H. M. Somerville, as referee. The printed copy of her testimony, taken at this time, indicated that in answer to questions she said that she had inspected the necklace several times in Cartier's and in Citroen's stores in Paris. Sometimes the pearls were loose and sometimes strung, and changes were made at times in the identity of the pearls. The last time she saw the pearls at Citroen's was in May, 1906. She said that she had worn the necklace a number of times while she was in Paris. The price she paid was \$340,000. She said that she did not pay for the pearls in Paris, but agreed to pay that price for them on their delivery to her in this country. She said that payment was not all in cash, and that she turned over a necklace which she had previously bought from Tiffany & Co., and on which Mr. Citroen had allowed her \$52,000. The balance she paid in cash, after the pearls were delivered to her at her home in Newport. Since the delivery of the pearls to her she has worn them as a necklace, she says, and had added six new pearls to the original 37.

The 37 pearls weighed 985 grs., an average of 26.62 grs. each. The central pearl weighed 53 grains; the first pair, 83 3/4 grs.;

the second pair, 78 3/4 grs.; third pair, 75 3/4 grs.; fourth pair, 63 3/4 grs.; fifth pair, 62 3/4 grs.; sixth pair, 58 3/4 grs.; seventh pair, 53 3/4 grs.; eighth pair, 51 1/2 grs., and ninth pair, 50 3/4 grs. The 18 smaller pearls weighed 352 3/4 grains.

Mr. Smith argued that as the pearls were imported in a loose condition, not strung, it was not material whether at any other time, before or afterward, they were strung. He said that the Government has no right to take into account anything further than the condition of the pearls at the time of importation.

Mr. Smith cited the Neresheimer, the Tiffany and other cases. Mr. Smith pointed out that drilled pearls and assorted pearls had been held to be pearls in their natural condition. He also called attention to the distinction made in the first Tiffany case that unless the collection of pearls is such as to give to the pearls a greater value than they have if sold separately, then the collection cannot be considered a necklace. In this case evidence was presented that the pearls were worth as much considered separately as when regarded as a necklace.

Mr. Nichols disputed all these points. He argued that the tying up of the large amount of capital involved in making a collection of pearls, such as this, necessarily added to their value, or the dealers would not collect them.

The attorneys argued at length on the issues involved and agreed to submit briefs to the court, the judge reserving decision.

Importations at the Port of New York.

Weeks Ended Feb. 16, 1907, and Feb. 15, 1908.		
	1907.	1908.
Glass, China and Earthen Ware:		
China	\$65,058	\$96,415
Earthen ware	7,709	13,733
Glass ware	24,916	27,153
Optical glass	468	1,168
Instruments:		
Musical	14,171	7,637
Optical	9,062	7,707
Philosophical	5,567	4,315
Jewelry, etc.:		
Jewelry	13,630	13,748
Precious stones	\$41,892	41,043
Watches	42,715	20,430
Metals, etc.:		
Bronzes	2,342	29
Cutlery	54,664	41,598
Ducten metal	1,854
Platina	97
Plated ware
Silverware	59
Miscellaneous:		
Alabaster ornaments	29
Amber	2,700	1,380
Beads	5,660	3,599
Clocks	6,410	2,437
Fans	4,748	7,189
Fancy goods	8,779	5,562
Ivory	9,410	19,954
Ivory, manufactures of.	191	28
Marble, manufactures of.	19,096	6,335
Statuary	9,216	2,292

Market Price for Silver Bars.

The following are the quotations of silver bars in London and New York, as reported by Zimmermann & Forshay:

	London.	New York.
	.999 Basis.	
Feb. 18.....	26 1-16d.	\$58 1/2
" 19.....	25 15-16d.	.58 1/4
" 20.....	25 15-16d.	.58 1/4
" 21.....	25 3-4d.	.57 3/4
" 22 (Holiday).....
" 24.....	25 11-16d.	.57 3/4

Joseph Boehrer, Viroqua, Wis., has sold out to James W. Lucas owing to ill health. He will reside hereafter in Durand.

Cutting of the Cullinan Diamond for King Edward of England.

AMSTERDAM, Feb. 13.—The Cullinan diamond has been successfully cleft into three sections. The largest portion weighs about 1,000 carats, and when polished will be pear-shaped. The stone is not quite free from blemishes, but it is expected that these will be entirely removed in polishing.

The ultimate weight of the stone is unknown, but Mr. Asscher states that when polished it will be by far the largest diamond in the world.

The King's diamond (the Cullinan), the largest in the world, has been cleft in Amsterdam by Joseph Asscher with complete success. Cleaving is the preliminary to the cutting of the gem, and was accomplished in the following manner: The diamond was embedded in cement, and the sharpest diamonds available were bought to make the first incision. The making of the incision took several days, says the London *Evening News'* special correspondent. Next, a specially made knife blade of finest steel was fitted into the incision, and then Mr. Asscher struck a terrific blow on the knife-blade with a thick steel bar. This cut the stone in twain.

The next process is the cutting, which will be entrusted to Henri Koe, who will work for a whole year in a locked room with three assistants. His daily hours of labor will be from seven in the morning until nine o'clock at night. A watchman will keep guard outside the door of the room, and two other watchmen will always be on guard in the building.

The diamond will be cut by being pressed against a disc oiled with a mixture of diamond dust and oil, and revolving 2,400 times a minute. At night the great gem will be placed in a special safe in a strong room with walls of iron and cement 2 1/4 feet thick. The head of the Asscher firm, armed with a revolver and accompanied by 10 of his staff, places the gem in the safe and takes it out night and morning.

Games Rolled by the Jewelers' Bowling League of New York.

The following were the scores of the teams of the Jewelers' Bowling League in the games rolled last week:

Feb. 17.—Aikin-Lambert Co.....	706	865	862
vs. L. E. Waterman Co.....	665	772	702
Feb. 18.—Cooper Diamond Co.....	851	813	872
vs. A. A. Webster & Co.....	750	774	774
Feb. 19.—H. W. Wheeler & Co.....	755	815	772
vs. N. H. White & Co.....	817	873	839
Feb. 20.—Tiffany & Co.....	807	783	851
vs. C. F. Wood & Co.....	758	836	780
Feb. 21.—Jos. Fahys & Co.....	*906	830	836
vs. Cross & Beguelin.....	*906	894	898

STANDING OF TEAMS.

	Won.	Lost.	High score.	Per cent.
Cross & Beguelin.....	35	13	1,017	.729
N. H. White & Co.....	35	13	1,014	.729
Cooper Diamond Co.....	34	14	1,022	.708
C. F. Wood & Co.....	25	14	943	.641
Tiffany & Co.....	29	19	969	.604
Aikin-Lambert Co.....	26	22	967	.542
Jos. Fahys & Co.....	25	26	906	.490
A. A. Webster & Co.....	16	32	916	.333
H. W. Wheeler & Co.....	10	29	922	.256
J. King Optical Co.....	10	35	889	.222
L. E. Waterman Co.....	7	35	852	.159

*Extra Frame—Jos. Fahys & Co., 77; Cross & Beguelin, 96.

WM. S. HEDGES & CO.,

IMPORTERS AND CUTTERS OF

DIAMONDS.

Precious Stones and Pearls.

170 Broadway, Corner Maiden Lane, New York.

27 Holborn Viaduct, London.

R. C. SAUNDERS, Pres.

W. V. LAURINO, Vice-Pres.

JOSEPH P. MEURER, Treas.

SAUNDERS, MEURER & CO.

CUTTERS AND IMPORTERS OF **DIAMONDS** AND OTHER **PRECIOUS STONES**

FINE PEARLS AND FANCY GEMS

65 Nassau St., Cor. John St., Prescott Building Telephone, 1613 Cortland New York

North Attleboro.

Robert Clampitt has returned from his initial trip for C. Ray Randall & Co.

W. C. Dabol, New York representative of G. C. Hudson & Co., was at the factory the past week.

Oscar H. Hornig returned, Friday, from an extended southern trip for Coddling & Heilborn Co.

George Cheever, of Cheever, Tweedy & Co., observed on Saturday his 62d birthday in an informal way.

S. E. Coombs made his first trip for the Paye & Baker Mfg. Co., last week. He traveled through New England.

There was excitement at the T. I. Smith Co.'s factory last Thursday. The fireman stopped and ran out a line of hose before it became known that the alarm was a mistake. The wrong box signal came in at the fire station and the firemen were called to the Smith factory when in reality the blaze was in Oldtown.

Edward Kent, a well known Providence jewelry salesman, Thursday, was summoned to North Attleboro by the death of his brother, James L. Kent, who died from burns received in a fire. Mr. Kent was at the time invalid and confined to bed. Before he could be rescued, he was badly burned and death came a few minutes later.

Cards have been received announcing the coming wedding of Frederick Mason Cool to Miss Ruth Elizabeth Vorhis, daughter of Mr. and Mrs. Albert Barnes Vorhis, Yonkers, N. Y. The wedding will take place Thursday evening, March 5, at the home of the bride, 261 South Broadway. Mr. Cool is the New York representative of Whiting & Davis.

Manufacturers are receiving frequent summons to take municipal offices. William H. Bell, Louis E. Freeman, of Strake & Freeman, and Christopher Dobra, of P. S. Freeman & Co., are candidates for selectman; John H. Peckham and H. F. Barrows are prominently mentioned for town treasurer; Wallace G. Franklin is a candidate for the municipal electric light board and John P. Bonnett is a candidate for trustee of the library.

Grand Exalted Ruler John K. Tener, of Charleroi, Pa., head of the Elks in the United States, visited the North Attleboro jewelry factories last Monday. He inspected the H. F. Barrows Co., T. I. Smith Co. and G. K. Webster Co. shops. At the Barrows factory each member of the suite was given a gold chain fob; at the Smith shop presents of buttons and pins were made, and at Webster's a silver match box with a clock's head engraved thereon was given.

The jewelry store of Henry F. Beaudry in the Cushing building, Rockland, Mass., was entered by burglars Feb. 19. Jewelry and silverware to the value of \$450 was taken by the thieves. Entrance was effected through a rear door, which was forced open. The cracksmen looked over the stock at their leisure and selected what they wanted. It is the custom of Mr. Beaudry to put his more valuable jewelry in the safe and no attempt was made to blow it open. There is no clue to the perpetrators of the crime.

Goodfriend Bros.

IMPORTERS OF PEARLS

Sapphires
Rubies
Opals
Emeralds

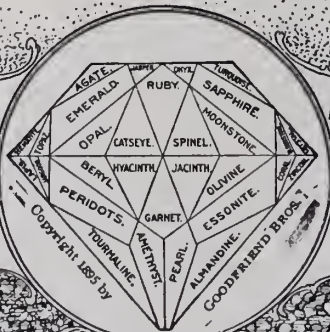

Aquamarines
Peridot
Gem Coral
Tourmalines

and OTHER
Precious and Imitation Stones

PEARL-OPAL-CORAL
& AGATE NECKLACES

PARIS:
10 Rue Cadet.

PROVIDENCE:
212 Union St.

9-11-13
Maiden Lane
NEW YORK

Geo. Brunswick, N.Y.

Providence.

Lonis Samuels, 157 Sheldon St., has started on the road with his samples.

W. B. Shaw, who is buyer for The Fair, Chicago, was in town last week and left several orders with local houses.

Vennerbeck & Chase have opened their new factory in the Doran building. The plant is fitted up in modern style.

Joseph S. Harris, a representative of the Excelsior Jewelry Co., Halifax, N. S., was in this city last week on a purchasing trip.

The factory of Smith Bros., 34 Basset St., has been working overtime for some time past. There has been a large demand recently for the class of goods manufactured by this concern.

Horace Remington, who has a large gold refinery in this city, has secured a cottage at Rockledge, Fla., where he will remain the rest of the winter season. R. L. Griffith and E. L. Spencer, two other jewelers, are at that place.

The Hopkins & Cannon Co., which will do an electroplating business, has organized with a capital of \$10,000. It was incorporated under the Rhode Island laws, last week. The incorporators are: Walter A. Hopkins, Charles E. Cannon and Alexander McCoughlin.

Owen White, an unemployed silversmith who worked in the Gorham factory in Elmwood until December last, committed suicide in his home at 31 Grand St., Monday morning, by placing a flexible tube in his mouth and turning on the illuminating gas. He owned his own house. It is thought that he was despondent because of ill health.

The employes of Silverman Bros. factory in the Doran building met last week and organized a relief association. The association will provide relief for sick and disabled members, and may also assist those who are out of work. The temporary officers are: I. Silverman, chairman; Sarah Goldberg, secretary, and John Silverman, treasurer.

The Gorham Co. recently delivered to the city of Philadelphia a bronze statue of President McKinley, which is to be set up in front of the City Hall in that city. The statue is to stand on a granite pedestal, the figure of the martyred President being eight feet tall. The casting is made from the design of Charles Lopes, who died before he could finish his work. The sculpturing was finished by Isadore Konti.

Macpherson, Roubaud & Co., who recently incorporated their business, have leased the entire fifth floor, in the new Doran building, 150 Chestnut St. This building, which has just been completed, is admirably situated and arranged especially for jewelry manufacturing, which, combined with the latest and most improved machinery which has been installed, will give excellent facilities to the new corporation.

A meeting in the interests of the unemployed was held in the Governor's room at the State Capitol, Friday afternoon, Governor Higgins presiding. It was stated by the mayors of five cities of the State and delegates of different charitable societies and labor unions that there are 39,000 persons unemployed in Rhode Island now, and that it is necessary something must be done

for them. Of this number it was stated a large proportion are jewelry workers. Nothing definite was decided in the matter. The following addressed the meeting: Speaker R. P. Burchard, of the House of Representatives; Mayors McCarthy, of Providence; Kenyon, of Pawtucket; Parks, of Woonsocket; Riley, of Central Falls, and Acting Mayor Shepley, of Newport.

The report of the Collector of the Port of Providence for the past week shows that the demand for European jewelry supplies is not falling off. From Bremen came five packages of imitation precious stones; from Halifax one package of jewelers' sweepings; from Hamburg two packages of imitation precious stones; from London one package of gold leaf, and from Southampton one package of jewelry.

A sneak thief, whom the local police are satisfied is a professional "penny-weighter," or jewelry store thief, stole a solitaire diamond ring valued at \$150 from a tray in the Tilden-Thurber Co.'s store on Westminster St., Friday evening. The thief was a well-dressed young man who entered the store in the afternoon and went at once to the diamond counter, where Captain Taber, an employe of the concern, was standing. Captain Taber has had dealing with all sorts of persons during his connection with the store and is always on the alert for crooks; so, while he displayed his wares he watched his customer narrowly, and saw him remove a ring valued at \$150 from a box and with a dexterous movement substitute in its place a cheap diamond worth probably \$5. Reaching over the counter the clerk grabbed the thief and ordered him to return the good ring. The man with an oath broke from his captor's grasp and ran from the store out into Westminster St. A policeman was standing there and gave chase, but the crook escaped.

Attleboro.

Fred E. King, emblem manufacturer, has been seriously ill lately.

Ralph H. Cole, dealer in Masonic emblem goods, has recovered from a long illness.

Edward A. Wales, retail jeweler, has been appointed town sealer of weights and measures.

Attleboro associates and friends received attractive souvenirs last week from Charles M. Robbins, of the Chas. M. Robbins Co., mailed in Honolulu.

Karl M. Wendelstein, proprietor of an engraving and designing concern, made a generous gift of land to the town last week for street improvements.

Arthur A. McRae, of McRae & Keeler, has the congratulations of his friends on the recovery of his young son, Arthur A., Jr., from a long and critical illness.

Peter Nerney, head of the Bay State Optical Co., is on a combined health and pleasure trip to Jamaica. From a point 900 miles at sea he sent a wireless home.

Walter E. Sanford, for some years a manufacturing jeweler here and later a retail jeweler at Oak Bluffs, has taken the trusteeship of a large concern dealing in clay.

Hon. Sidney O. Bigney, of S. O. Bigney & Co., was the principal speaker Saturday before the Ancient and Honorable Artillery

company of Boston, and expressed hopeful views concerning the international situation in the Far East.

A mass meeting of unemployed, largely jewelers, has been called for Feb. 29, in G. A. R. hall, to ask the town as a body for preference in all work over outside residents, and for the immediate construction of large municipal improvements to provide work for the men.

A note in last week's issue, in speaking of James Carley as the new foreman of C. O. Sweet & Son Co. was an error, as Mr. Carley has become employed by the concern, but not as foreman. F. L. Day, formerly the assistant foreman, has succeeded Mr. Hanlon as the foreman.

Walter E. Haywood, head of Walter E. Haywood & Co., has been removed to a hospital near Boston for treatment. He has suffered an almost complete nervous breakdown, due to overwork last year, when his factory ran both day and night to keep up with orders. He applied himself extremely long hours to his work at the factory, directing production.

Caucuses were held last week and nominations for town offices bestowed on William Nerney, of William Nerney & Co.; Walter J. Newman, formerly of the Horton-Angell Co.; Harrison C. Swift, formerly of H. C. Swift & Co.; Thomas G. Sadler, of Sadler Bros.; Aldro A. French, of the D. E. Makepeace Co.; Charles E. Bliss, formerly of Bliss Bros.; Albert S. Ingraham, of A. S. Ingraham & Co.; Thomas E. McCaffrey, of the Bennett, Hassan Co.; Fred L. Torrey, of F. L. Torrey & Son.

Word was received, last week, of an extensive reduction on insurance rates for centrally located property. It had been previously announced that the jewelry factories in the district involved would not benefit, owing to the fact that they are already so well protected by automatic sprinklers and alarms, and by the presence of two fire stations in the heart of the factory district. The James E. Blake Co., however, received a reduction on its acid headquarters, a separate building, and it was also granted on property owned by Clarence L. Watson, of the Watson-Newell Co. and by Charles H. Tappan, of the D. F. Briggs Co.

Keegan and Rosenkrantz, known throughout the Orient as "the Irishman and the Jew," were in Attleboro last week, securing samples for a new and lengthy trip. This was their first visit here in over three years, the time being spent in a tour of Japan, China, British India, Siam and other far Eastern points. They carry the lines of the D. F. Briggs Co., McRae & Keeler and the Bay State Optical Co. Two more unique characters would be hard to find in the trade. They are typical salesmen of New England Yankee shrewdness at a bargain, and provide Oriental dealers not only with jewelry and optical goods, but many other lines as well. The length of their next trip is not known, but they will start with up-to-date samples. They left for New York Saturday.

Jeweler Wm. F. Ehmann, of Wm. Ehmann & Son, 316 Elk St., Buffalo, N. Y., is out and around again after three weeks in the hospital, where he went to undergo an operation.

EICHBERG & CO.,

IMPORTERS AND CUTTERS OF

DIAMONDS,

65 NASSAU STREET, (Prescott Building.) NEW YORK.

HIMALAYA MINING COMPANY

MINERS AND CUTTERS OF
PRECIOUS AND SEMI-PRECIOUS STONES

537 FIFTH AVENUE

LONDON
PARIS

NEW YORK

OBERSTEIN
PROVIDENCE

CAMEO GOODS

are now in style.

We manufacture BROOCHES in a variety of designs in CORAL, SHELL and STONE.

Schultz & Co., Inc.

Makers of "Business Builders"

An up-to-date line of 10K. jewelry of all kinds

Factory and Office

91 Oliver St. Newark, N. J.

TradeMark



New York Salesroom

12-14 John St. N. Y. City

After July 1, 1908, this Company will change its name to

Percy M. Layman

LAYMAN & STRAUS CO.

Sydney C. Straus

Pittsburg.

Among the out-of-town buyers who were in Pittsburg this week were C. L. Kuhn, Scottsdale; Lewis Brehm, West Newton, and F. H. Hayes, Washington, Pa.

August Loch, the North Side dealer, who recently moved into his new store, is having a few alterations made. His building is one of the best equipped in the two cities.

E. W. Hill, of Goddard, Hill & Co., who fought against annexing Bellevue, his home town, with the city of Pittsburg, came out victorious, the people defeating the issue almost two to one.

John Gilmore, a well-known jeweler and watchmaker, last week served on the jury which tried Thomas Heathcote, aged 69 for the murder of his wife on the North Side. Heathcote was acquitted.

The W. J. Johnston Co. has all of its force of travelers on the road. W. J. Johnston, who leaves this week on a business trip to New York, says that he has been surprised at the amount of business that is being done. His men insisted on going out three of them being in the south, and he is now glad that he let them go.

There are indications that rents will be reduced in Pittsburg. There are said to be 24 vacant store rooms in Wood St., within a distance of six squares. This is one of the busy streets of the city. Some of the jewelers who earlier in the year rented quarters in office buildings, now report that they have been offered quarters for 15 to 20 per cent. less than they pay.

L. J. Vilsack & Co., at present located in the Farmers' National Bank building on Fifth Ave., but who recently gave up the store because of a threatened advance in the rent from \$6,000 a year to \$15,000 per annum, have leased a store at 539 Wood St., formerly occupied by Chas. O'Brien Co., and will open there April 1. Mr. O'Brien, whose concern is now out of business, was formerly identified with the Vilsack house. The firm expects to remodel the store and make it attractive as possible.

Three match games were bowled last Thursday night by the recently organized Jewelers' Duckpin League, on the Dispatch alleys. Three new teams have been added since the initial organization. The E. Roberts & Sons Co. watch department team won two out of three games from the W. W. Wattles art department team; the Wattles jewelry department team won two from the Terheydens, and the Reed team lost three to the E. P. Roberts & Sons jewelry team. Star, of the Terheyden team had high score last week, 107; Stitt, of the Wattles team, had 93 to his credit.

The store of Earl Klingensmith, at Leechburg, Pa., was destroyed by fire last week entailing a loss of from \$1,500 to \$2,000 according to information received here. The fire started about 10 o'clock at night and caused a total damage of \$75,000, the destruction of two buildings, and the burning out of 10 business establishments. The fire had its origin in the basement of the two-story brick building in Market St., which the Klingensmith store was situated and spread to an adjoining building owned by a Mr. Long. Both structures were entirely burned. It is not known just what

S. PITZELE

51-53 Maiden Lane NEW YORK

Manufacturer of



327

FINE

Diamond Mountings

ALSO

Bracelets

AND

Dwt. Goods



306

SPECIAL ATTENTION GIVEN TO ORDER WORK



688



325



329



218



435



348

r. Klingensmith's loss amounts to, but is thought to be in the neighborhood of 2,000, and is said to have been partly covered by insurance. Mr. Klingensmith will re-engage in business.

It has been reported here for several days at J. T. Montgomery, local manager for L. A. Mead & Co., will return to the Chicago office in a short time and that the jewelers operating out of the Pittsburgh office have been withdrawn from the road. Mr. Montgomery left for the east last week and attended the dinner given by the Philadelphia jewelers Saturday night, and goes on from there to New York. At the office of L. A. Mead & Co. it was stated that nothing was known concerning the report, other than that Mr. Montgomery did intend to return to Chicago, presumably, however, because he has been elected vice-president and general manager of the company, and that his election to that position will necessarily require his attention there.

Harrisburg, Pa.

The annual banquet of the West Chester (Pa.) Business Men's Association was held at the Turk's Head Hotel, that city, Feb. 17. While in the act of boarding a Hammelstown trolley car at Cameron and Market streets, Feb. 22, David Glasberg, a jewelry thief for whom the police in various cities have been on the lookout since last October, was arrested by Patrolman Frank. Upon being asked his name by the officer Glasberg gave it as Harry Frank. Glasberg, who is a former Harrisburger, is wanted in Washington, D. C., for the larceny of more than 40 gold watches from a jewelry store here last October. The police of Washington, knowing that Glasberg had married Miss Capin, of this city, concluded that he would show up here after the excitement over the burglary had somewhat subsided. Although the house was watched since that time it was not until yesterday afternoon that Glasberg was seen, and the Washington police department notified.

Atlanta, Ga.

J. C. Mellichamp, now in bankruptcy, is offering a settlement to creditors at 45 per cent. Henry Sanders was arrested Wednesday charged with stealing several hundred dollars' worth of jewelry from Julius Simons, 96 Washington St. Immediately after the robbery was reported, two detectives happened to enter a Decatur St. pawn shop while Sanders was pawning one of the rings. He was arrested, and when his room was searched, all the missing jewelry was found except a large clustered diamond ring. The E. V. Haynes Co., this city, has joined the jewelers who are seeking to reach the public the correct conditions in the diamond trade by having published in the local papers in full the editorial which appeared in THE CIRCULAR-WEEKLY of Jan. 5, headed "The Strength of the Diamond Market." This article, which the Haynes Co. had published in the Atlanta papers recently, appeared under the heading of "Prices of Diamonds Going Upward," and evoked considerable favorable comment in the jewelry trade as well as bringing letters of thanks to the E. V. Haynes Co.

BLACK OPALS

REMARKABLE :: IRIDESCENT :: BEAUTIFUL

Black Opal, a recent Australian discovery, is one of the most beautiful stones hitherto found.

With it many inimitable jewelry creations are possible that must appeal in a forceful manner to the trade.

These remarkable stones exhibit a wonderful play of brilliant colors, ranging from light to cobalt blue, with flashes of violet, from delicate shades of green to peacock green, and all shades of reds, merging into orange and yellow tints.

Black Opal is a worthy addition to the finest stock, and jewelers will find it a welcome "Trade Magnet."

We can furnish these stones in various sizes and shapes, and their full merits can only be appreciated by being seen.

We make a specialty of AUSTRALIAN and MEXICAN OPAL MATRIX.

BUY FROM THE CUTTERS

AMERICAN GEM & PEARL COMPANY

14 & 16 CHURCH STREET, NEW YORK

London, 16 Holborn Viaduct

Paris, 39 Rue de Chateaudun

FROM MINES TO MARKET

CORAL

All Kinds of Coral Specialties for Jewelers

**DROPS
BUTTONS
LENTILLES**

**CORAL
NECK-
LACES**

All Shades and Sizes

Graduated and Uniform



CORAL

**Extra Rose
CORAL
A Specialty**

Gold Medal
St. Louis, 1904

Grand Prix
Liege, 1905

BORRELLI & VITELLI

3 Via Amedeo,
Terre del Greco Italy

401 Broadway, New York
Telephone, 5412 Franklin

19 Rue d'Hauteville,
Paris, France

**ARTHUR REICHMAN
BUYS AND SELLS**

AMERICAN BAROQUE PEARLS

65 Nassau St.

New York

Lancaster, Pa.**TRADE CONDITIONS.**

The Lancaster jewelers are hopeful now of improved trade because the Lancaster County leaf tobacco crop is again under fairly active sale. The tobacco crop of last year brought the growers of Lancaster County over \$3,500,000, and this was a big factor in the local trade.

A. K. Brubaker, Columbia, is ill. Jacob Dubs has opened a repair shop at Mifflin.

J. W. Mayer, of Powers & Mayer, paid his first visit to the Lancaster trade last week.

Alex. McIntyre, a former Hamilton Watch Factory employe, died last Thursday in Chicago of pneumonia.

F. A. Herber, M. Lang and Charles F. Reisner, of the H. S. Meiskey Co., are now covering their respective territories.

S. Kurtz Zook and A. W. Moyer, manager of the Non-Retailing Co., were guests on Saturday evening at the annual banquet of the Philadelphia Jewelers' Club.

John B. Roth, Jr., has returned from a trip to Philadelphia. He will now make a complete line of Masonic emblems and will go on the road himself in a short time.

Charles E. Foose, of the Non-Retailing Co., is off on a two weeks' trip to Philadelphia and Washington, D. C., and Howard W. Detterline, of the same company, has gone to the west.

Homer M. Harkness, Reedville, Pa.; E. G. Hoover, Harrisburg; P. J. McClintock, Cleveland, O.; Stephen L. Benson, Baltimore, and Martin Collier, Erie, Pa., visited Lancaster, last week.

Allan P. Diller, Edmond Brallier, and Arthur B. Bonton, New Orleans jewelers en route to New York, stopped over in Lancaster for a couple of days last week to see old friends. Mr. Brallier resides here many years ago.

William Dorsey, who stole diamond jewelry from George Ryan, at Pottsville, Pa., a couple of weeks ago, was arrested here last week by Chief of Police Bushong, and some of the articles were recovered. The prisoner was taken to Pottsville for trial.

G. William Reisner, manufacturing jeweler, has just finished a set of 13 handsome prize medals for athletic contests at the Y. M. C. A., Lincoln, Nebr. He has also just completed two solid gold oratorical medals for the High School of Shippensburg, Pa., and a number of faculty pins for Smith College, Amherst, Mass.

Edgar J. Fox, watchmaker for George L. Parker, Rocky Mount, N. C., has entered the Ezra F. Bowman Technical School for an advanced course in watchmaking. Mr. Parker's son, George L., has entered the school as a student in engraving and watchmaking. Clyde McCormick, Parkersburg, W. Va., has returned to the school after an attack of illness.

The parents of James E. and John F. Ziegler, who were formerly employed by John B. Roth, Jr., of this city, but of late located at Tonopah, Nev., where the first named was general manager for George Blakeslee & Co., have learned by letter that their sons have removed to San Francisco and opened a jewelry manufacturing establishment of their own. James E. Ziegler was only recently married.

THE CLOSEST relationship exists between us and the Jobber. The latter is your convenient source of supply.

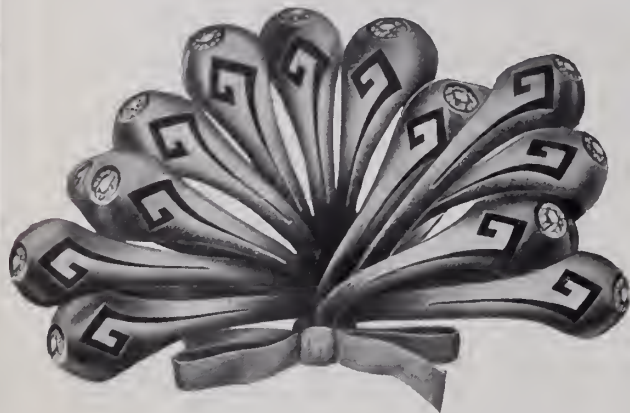

**BUY
UR
RINGS**

from your
JOBBER
as cheap as from
ring makers

The Untermeyer-Robbins Co.

Seventy-One Nassau Street, New York



GOLD PLATED Art Jewelry of every description, and the Schickerling patented Elk and Eagle lines. Fine Diamond Mountings.

¶ Makers of fashionable, popular price, ten and fourteen karat Solid Gold Jewelry. Card Holders for all Lodges, solid gold, sterling and plated. Artistic Novelties.

SCHICKERLING MFG. CO.

391-393 Mulberry Street, NEWARK, N. J.

CONRAD SCHICKERLING, Pres.

T. M. SCHROEDER, Treas.

The Scarab or Sacred Beetle

WROUGHT in cloisonne enamel with beautiful transparent and iridescent colors. Made in *Belt pins, Brooch pins, Hat pins, Stick pins, Cuff links* or *Watch fobs*. Prices from \$3.00 to \$36.00 per dozen.

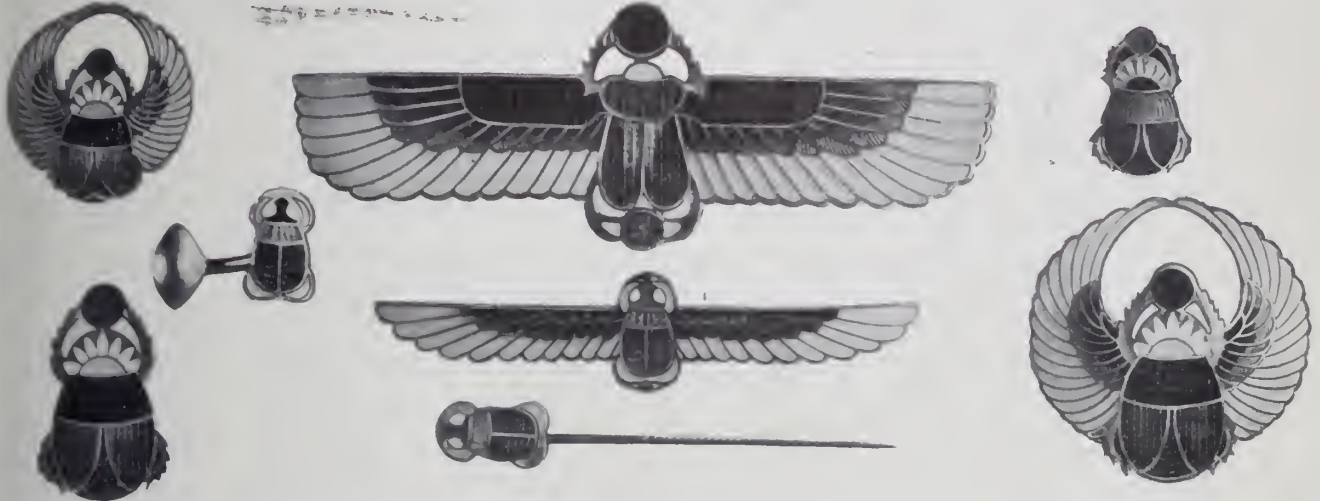

This most ancient Egyptian symbol of good fortune is the best novelty of the season. Samples sent on approval.

The Shepard Manufacturing Co., Silversmiths, MELROSE HIGHLANDS, MASS.

LEATHER BRACELETS FOR WATCHES

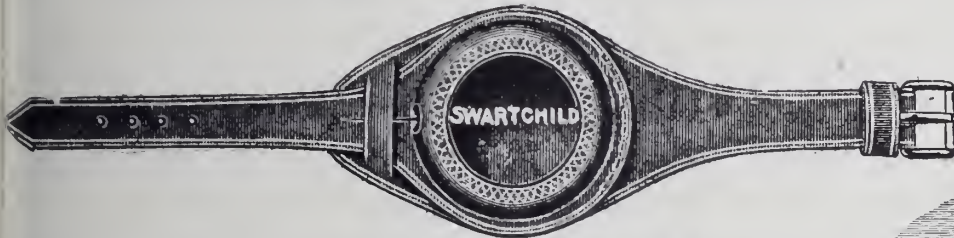

No. D 10. Best quality leather, each, \$0.40; per dozen, \$4.50

SWARTCHILD & COMPANY

Heyworth Building, CHICAGO

Extra Fine Selected
CUTTLEFISH BONE
for forming ring moulds, etc.

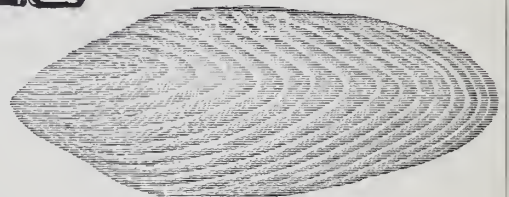

Each piece 6 to 7½ inches long
Price per dozen pieces, . \$0.75

The Largest Exclusive Jewelers' Supply House in the World

If you have not a copy of our double sized 440 page Catalogue write at once.
Sent gratis upon application.

Trade-Marks

of the Jewelry and Kindred Trades. Second Edition. Price, **\$3.00**. The Jewelers' Circular Publishing Co., 11 John Street, New York.



American Watch Case Co.,

9-11-13 Maiden Lane

A.W.C.CO

New York

GORHAM SILVER

¶ The unexampled variety and diversity of Gorham silver designed to serve as Prizes and Trophies, are such as must appeal to the jeweler called upon to meet the oft-times fastidious demands of club committees and others charged with the task of selection.

¶ Vases, Loving Cups, Tankards and Special Pieces of every description, from the simplest to the most elaborate, in every style and at every price. Such, indeed, as cannot fail to appeal to the most exacting taste, are always in stock.

¶ Nor is the range of selection confined even to these wide limits. The Gorham Company is always ready to forward at short notice attractive sketches of artistic designs specially prepared to meet individual demands.

THE GORHAM COMPANY,



CHICAGO,
137 Wabash Ave.

Silversmiths and Goldsmiths

Fifth Avenue and 36th Street, New York.

BRANCHES:

NEW YORK,
23 Maiden Lane.

SAN FRANCISCO,
Temporary Office:
1103 Broadway, Oakland, Cal.

LONDON,
Ely Place.



WORKS: Providence and New York.

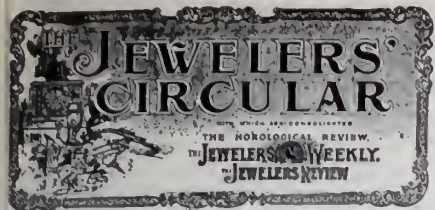

PUBLISHED EVERY WEDNESDAY BY
THE JEWELERS' CIRCULAR PUB'G CO.

J. J. Mulford, Pres. & Treas. V. S. Mulford, V. P. & Sec.

11 JOHN ST., COR BROADWAY, NEW YORK.

TELEPHONE:
 149 CORTLANDT.

CABLE ADDRESS:
 JEWELAR, NEW YORK.

VOL. LVI. FEBRUARY 26, 1908. No. 4

Subscription in United States and Mexico, **\$2.00**
 Dominion of Canada, **3.00**
 Other Countries in Postal Union, **6.00**
 Single Copies, **.10**

Remit by check or money order. Remittances in money are at sender's risk.

Index to News and Special Articles.

	Page.
Artistic Offertory Basin for Trinity Cathedral, Cleveland, O. Illustrated on front cover; text on.....	35
Ceylon Pearl Shells.....	35
Madagascar Grants Two Concessions for Government Pearl Fisheries on the West Coast.....	35
Retail Jewelers of Hamilton, Ont., Enjoy Banquet.....	35
The Occult in Gems and Jewelry.....	37-39
Imports of Clocks, Jewelry, etc., Into Canada. Contracts for Watches, Clocks, etc., Awarded by Navy Department.....	39
Examination in the Bankruptcy of Jos. Brown & Co. Continues at Chicago.....	41
Schedules of Horowitz Bros., New York, Filed in the Bankruptcy Court.....	41
Annual Convention of the Indiana Retail Jewelers' Association Held at Indianapolis.....	43-45
Creditors of Max Schucht, Milwaukee, Wis.....	45
Pittsburg Jewelers Escape With Little Damage From Effects of Recent Floods.....	45
Cincinnati Diamond Broker Brutally Assaulted by Man Who Tried to Rob Him.....	47
Girl Gets Verdict Against Cincinnati Jeweler for False Arrest, Though He Denies He Accused Her.....	47
Thieves Smash New Orleans Jewelers' Window, Steal Rings Worth \$15,000 and Escape.....	47
Goods Received and Contracts Awarded by Government.....	47
Annual Banquet of the Jewelers' Club of Philadelphia.....	48, 49, 50, 51
Louisville Jewelers Too Smart to Be Fooled by Tricks of a Clever Swindler.....	51
Death of Thomas E. Bruner.....	51
Gold Bars Withdrawn and Exchanged.....	51
Death of George Deuble.....	52
Government Discontinues Suits Against Byron L. Strasburger & Co.....	52
Citroen Pearl Case Argued Before United States Circuit Court.....	53
Importations at New York.....	53
Silver Market.....	53
Cutting the Cullinan Diamond.....	53
Games Rolled by Jewelers' Bowling League.....	53
Sol. Lindenborn, New York, Offers Creditors a Settlement.....	67
C. W. Hadley Makes an Assignment.....	69d
Patent Department.....	80, 81, 83
Some Newspaper Comments on the Anniversary Number.....	83
Sir Julius Wernher on the Conditions in the Diamond Trade.....	83
The Mainspring and Its Dimensions.....	85
Clock of the Louis XVI. Period.....	87
Defects in the Electrical Clocks.....	87
Watch Repairing—(Continued).....	89
Horological Notes.....	89
Original Displays Made by Enterprising Jewelers.....	96
"Men Who Sell Things." A Book Giving Words of Counsel for Salesmen.....	96
A Representative Retail Jewelry Store of Atlanta, Ga.....	97
Workshop Notes and Queries.....	99
America's First Glass Factory.....	101
Glass Manufacture in Ireland.....	101
Alaska-Yukon-Pacific Exposition to Be Held at Seattle in 1909.....	103
Presentation Sword Designed and Supplied by a Brooklyn Jeweler.....	103

STATE Senator Thomas F. Grady, whose "silver tongue" amused the members of the jewelry trade at the 24 Karat Club's banquet a year ago in New York, has introduced into the New York Legislature a bill which is of special importance to merchants in many lines, inasmuch as the act makes it larceny to knowingly receive money in exchange for an article of food, drink, jewelry, confectionery or merchandise which is of inferior quality, or of less value, or composed of different materials than it is represented or claimed to be. The bill also makes it a misdemeanor to falsely represent a quality or character of the materials of which such an article of merchandise is composed. While the bill is general in scope and covers ground not heretofore touched upon in legislation, a part of such misrepresentation, as far as jewelry is concerned, is forbidden in the silver and gold stamping sections of the New York statutes, though the omnibus character of Senator Grady's bill would supplement these acts by covering every case of misrepresentation not specifically provided for in the Stamping Laws. Whether or not the bill will become a law it is as yet too early to determine, but its course in the legislature will undoubtedly be followed with interest by jewelers, as well as other merchants.

How Much Does It Cost to Sell Stock? **H**ow much does it cost to do business in the jewelry trade? What should be considered a legitimate profit that will cover the cost of doing business and leave the jewelry merchant a margin for a livelihood? These are questions which, in part or in whole, and in many forms, are often propounded by subscribers of this journal, and the first, on which the second is based, seems to be on a subject so interesting and so vitally important to the members of the trade that it is strange that more attention has not been given to it in the past few years. While it is true that no rule can be laid down as to finding the cost of doing business that will apply to all merchants and all localities, there must be some general principles involved which might be brought out through a proper and careful discussion of the subject by jewelers generally.

It is unfortunate that a large number of small merchants display intense ignorance upon this subject, even to the extent of considering that the percentage of profit which they add to the cost of stock is the profit that they should make in their business. Many merchants who take the trouble of figuring the amount of rent, clerk hire, illumination and heating of their store, etc., in their cost, forget to consider a depreciation in value of stock (by time, wear and tear) as a factor, while others who consider these factors forget to consider the interest on their capital invested as an amount which should be properly added to the cost of doing business.

Several inquiries have been received from jewelers asking us what should be the legitimate profit of a jeweler, but we think that before this can be considered by the average merchant he should first determine what is the cost of doing business, which

You are not apt to get business unless you ask for it. The best way to ask for business is through the advertising columns of THE JEWELERS' CIRCULAR-WEEKLY reaching weekly, thousands of buyers new to you.

should be added to the cost of the stock he purchases before figuring on his profit. Can any of our readers throw light upon this interesting subject? Our columns, as usual, are open to all who wish to give to the trade their ideas, their experiences, or their suggestions on the subject.

To Change the Name of the Jewelers' League. ACCORDING to a well-known writer on political economy, one of the

greatest factors determining the action of mankind on all subjects is sentiment, and, according to him, sentiment even when opposed to pure reason or arguments based on the formal laws of thought has often been able to impede progress and development and to keep life into a lost cause even for generations. It is this potent influence, sentiment, which will be the basis of the opposition (if any be formally manifested) to the amendments of the constitution of the Jewelers' League, which will come up for formal action at the adjourned annual meeting of the organization to be held tomorrow in New York, when the proposition to change the name of the organization to the Assurance League of America is finally decided.

The suggestion to change the name came up at the annual meeting last month, and was brought before the executive committee by a resolution favoring such a change, which was adopted after a short discussion. Though the arguments in favor of this change are strong, particularly as the League has in the past been getting a large number of members from trades in other than the jewelry lines, and has a chance of obtaining many more if the name is made general, nevertheless there are many members of the organization who have been in it for twoscore or more years who will be loath to part with the old name and will feel that the title given to the organization at its birth is one that it should carry through its life. However, it may be called to the attention of many of these people that even under the proposed name "The League," as it is affectionately called by many members, will still be "The League" whether "Jewelers" or "Assurance" be the first part of the title.

As was said before if there be any contest over the change it will be purely on sentimental grounds, but it is sincerely hoped by the officers and executive committee as well as a large part of the membership having the interest of the organization at heart that this will not be a case in which sentiment will prove as potent as some of our economists lead us to believe.

FIRST HANDS



CROSS & BEGUELIN

Importers and Cutters of Diamonds and Precious Stones

43 Rue de Meslay, PARIS

Telephone,
480 John

31 Maiden Lane, NEW YORK



The Silent Appeal

H. A. KIRBY

FINE
GOLD
JEWELRY

PROVIDENCE
NEW YORK

HAVE YOU EVER REFLECTED ON HOW A PRETTILY WROUGHT AND EFFECTIVELY DISPLAYED DESIGN WILL UNCONSCIOUSLY INFLUENCE A PURCHASE? HOW FIRST IT EXCITES ADMIRATION IN THE INDIFFERENT SPECTATOR, THEN IRRITATES THE DESIRE TO POSSESS, AND FINALLY BY ITS VERY IRRESISTIBILITY COMPELS HIM TO PURCHASE? IN EFFECTING SUCH A SALE, ONLY A FEW CONVENTIONAL REPRESENTATIONS ARE NECESSARY BY THE JEWELER, WHOSE PROFITS ARE A JUST REWARD FOR HIS SHREWDNESS IN EQUIPPING HIMSELF WITH SUCH JEWELRY. WE MAKE IT IN AN INEXHAUSTIBLE VARIETY—AT MODERATE COST.

Boston.

William A. Block, jobber in the Washington building, has sold out his branch business in Lawrence.

"Joe" Erlich, assistant to Harry J. Ogden, has recovered from an operation for appendicitis, performed a short time ago.

F. C. Beckwith, of the New York office of Joseph Fahys & Co., paid a visit to the Boston headquarters of the company last week.

George M. Poland filed his name at the State House last week as legislative agent, authorized to appear before all committees on all matters interesting the Boston Jewelers' Association.

E. S. Burnham, of Essex, Mass., has made an assignment. Mr. Burnham carried on a printing business in addition to dealing in jewelry. His liabilities are reported as in the neighborhood of \$4,000, with assets light.

There is some improvement in the demand from out-of-town retailers, and visits of buyers are more in evidence. Among those in town during the week were: Charles H. Sinclair, for N. C. Nelson, Concord, N. H.; S. G. Beers, Taunton; B. D. Loring, Plymouth; H. S. Hewitt, Brockton; L. R. Hapgood, Orange; E. T. Welch, Westboro; F. M. Weber, Hyannis; Fred Hendrick, A. P. Hendrick & Son, Nashua, N. H.

The many friends in this city of George Philbrick, Skowhegan, Me., heard with deep regret the news of his recent death. Mr. Philbrick, who was the father of J. R. Philbrick, now in business at Skowhegan, was well known in the jewelry trade for many years. He started in business about 1850, going to Skowhegan in 1865. He continued alone until 1898, when he admitted his son to an interest, the concern becoming George Philbrick & Son; the partnership was dissolved in 1900, when J. R. Philbrick succeeded to the business. The latter and a widow survive the deceased.

Utica.

A creditors' petition in bankruptcy has been filed against the G. W. Drake Cut Glass Co., of Corning, N. Y., by Charles Kahn, of Corning, and N. C. Knapp and W. J. Warner, of Buffalo, three note creditors, for \$7,500. A receiver has been appointed. The petition was filed so as to prevent a sale of the property under a judgment obtained in the Supreme Court by Lucy Denton Burt, of Corning.

Charles B. Mason, of this city, the receiver of George C. Smith, bankrupt jeweler at Watertown, has filed his report after turning over all assets to the trustee, Charles A. Phelps. His disbursements are \$128. The receiver reports that he made a demand upon S. Silverman, to whom Smith turned over \$1,200 worth of diamonds, to secure a \$400 claim, for a return of the jewels, but Silverman refused to comply. An injunction has been served on Silverman to prevent him from selling the diamonds.

During a fire which recently broke out in the First National Bank building, in Colorado Springs, Colo., the Ashby Jewelry Co. sustained a loss of \$1,000.

New York Notes.

M. J. Averbeck left Wednesday morning for Atlantic City, where he will spend a week or 10 days.

W. H. Saart, of the W. H. Saart Co., North Attleboro, Mass., was at the New York office Tuesday of last week.

The firm of Jacob Dreiver & Son, 560 Fifth Ave., is now known as Dreicer & Co. A new partner was admitted last week.

Erle R. Sheppard, manufacturers' agent, 13 Maiden Lane, visited Pittsburg last week in the interest of some of the concerns whom he represents.

Richard N. Oakman, who was at one time connected with the A. F. Towle & Son Co., silversmiths, died at his home, 130 Bedford Ave., Brooklyn, Monday of last week.

It was reported from Plainfield, N. Y., last week, that the William H. Rogers corporation of that town, whose trade mark is "not the Original Rogers," has decided to move to Muncie, Ind.

The new clock in the city library of the City Hall, which was ordered in 1904, was put up last week, but has not yet been started going. The clock, which is of white marble with exposed hands, cost \$200.

Abe Kassel, who was in the jewelry box manufacturing business at 675 Hudson St., and who recently sold out his stock, is now connected with Wolfsheim & Sachs, 35 Maiden Lane, who have bought most of the stock.

The Weinberg & Sudzen Co. has been incorporated under the laws of New York to deal in jewelry, with a capital of \$12,000. The directors are: Max Weinberg, Max S. Weinberg and Herman Sudzen, all of Brooklyn.

Daily papers during the past week stated that detectives have been searching for James A. Barry, once a Newark, N. J., jeweler. It is the opinion of Mrs. Barry that her husband had been kidnaped and held for ransom.

Edgar Huhn, of the Potter & Buffinton Co., left Feb. 15 for an extended trip through the Mediterranean and on the Continent. While in London Mr. Huhn will spend about two weeks with relatives, whom he has not seen in several years.

Ling & Stewart, 68 West Broadway, have just become the New York representatives for the West Silver Co., Taunton, Mass. The New York salesrooms of Ling & Stewart have been fitted with facilities for the display of the silverware.

Reuben Mason, vice-president and general manager of the Potter & Buffinton Co., 65 Nassau St., accompanied by Mrs. Mason, are having a pleasant stay in southern California. While in San Francisco and Los Angeles, Mr. Mason will visit his old acquaintances in the trade.

At a meeting of the American Institute of Mining Engineers, held last week, Dr. Geo. F. Kunz, of Tiffany & Co., and Henry Washington presented a joint paper dealing of the recent investigation they made of the diamond mine and the diamonds found in Murfreesboro, Pike County, Ark. The members of the Engravers' Art Club of New York will hold their sixth annual exhibition and dinner at Allair's Hall, Feb.

29. There will be a fine display of engraving and art, which will be permanent. The officers of the club are: G. A. Hollis (with the Gorham Co.), president; W. S. Wagner (with T. B. Starr), secretary, and C. J. Kuhr (with the Meriden Co.), treasurer.

The fourth and last day's sale of the collection of oriental art of Mrs. E. H. Conger, widow of the former Minister to China, took place at the American Art Galleries Saturday. The sale, which included pottery, glass, silver and enamel ware, realized \$10,781, making a total of \$37,411 for the entire sale.

A meeting of the creditors of Adolph L. Hodes, 65 Nassau St., who filed a voluntary petition in bankruptcy recently, was held last Thursday at the offices of Referec William Allen, 67 Wall St., at which time Henry Untermeyer was made a trustee in bankruptcy. The meeting was adjourned until Feb. 27.

Friends of Harry Larter, of Larter & Sons, were grieved to hear that he had been ill at his home with tonsillitis since Friday last. Mr. Larter, who is president of the Jewelers' 24 Karat Club, was unable to attend the Philadelphia Jewelers' Club banquet Saturday night, at which he was to be a guest of honor.

Judge Hough in the United States District Court has confirmed the composition settlement of Nathan Balyinson, 414 Broadway, against whom a petition in bankruptcy was filed in November. The settlement is on a basis of 25 cents on the dollar, payable, 10 cents in cash and 15 cents on notes, due in two, four and six months. The liabilities are \$16,243.

An involuntary petition in bankruptcy was filed Friday against the corporation of Holmes, Yolle & Evans, who conducted notion and jewelry stores in various parts of the country, the petitioning creditors being Louis Wolf & Co., whose claim is \$5,276; A. Frankenstein & Co., \$104, and A. & S. Solomon, \$3. Peter Alexander was appointed temporary receiver to continue the business for 15 days. The concern, which has retail stores at 350 Broadway and 162 W. 125th St., this city, also has branches at Jersey City, Ashtabula, East St. Louis, Freeport, Belleville, and Waukegan, Ill., Chicago and Milwaukee.

According to tables just compiled, the following figures of interest to the trade, as showing the relative import and export trade for the month of December, 1906, as compared with the same month in 1907: Clocks and watches imported in December, 1906, \$318,434, as compared with \$270,353 during the same month in 1907; diamonds and precious stones, \$5,311,038, as compared with \$382,717; jewelry, \$176,943, as compared with \$110,050. The domestic exports show the following figures for the same time: Clocks and watches, \$236,445 in December, 1906, as compared with \$232,645 in December, 1907; jewelry, etc., \$179,962, as compared with \$151,980.

The report last week giving the schedules of Eisler & Laubheim was apt to create an erroneous impression in regard to some of the claims scheduled, inasmuch as it did not state that some of the liabilities included by the bankrupts were contingent, and covered practically the same claims as were included in another part giving the direct li-

abilities. We are informed that some of these liabilities were on accommodation notes of creditors, and in scheduling these, the contingent liability on the creditors' notes discounted by the bankrupt was put down, as was also the direct liability on the note given in exchange. This in some instances made the total amount scheduled double the actual liability.

A meeting of the creditors of the Weisscr-Low Co., Pittsburg, Pa., was held at the Hotel Knickerbocker last Wednesday, at which time a proposition was made to New York creditors to accept 50 cents on the dollar in two notes of 25 per cent. each, payable in two and four months, the notes to be secured either by the Diamond National Bank of Pittsburg or some trust company acceptable to the creditors. Nearly all the creditors were in favor of this settlement. At a former meeting held at the same place on Feb. 17 there were about 100 creditors present or represented. It developed that the liabilities of the concern, which is a general department store, amounted to \$382,548.12, and that it had nominal assets of approximately a like amount.

The wedding of Seth Thomas, Jr., of the Seth Thomas Clock Co., and Miss Josephine F. Van Beuren Reynolds, daughter of Mrs. James Banks Reynolds, was solemnized Thursday afternoon in St. Mark's Church, 10th St. and Second Ave. The Rev. Hugh Birkhead performed the ceremony, assisted by Archdeacon Spurr and the Rev. L. W. Batten, rector of St. Mark's. Miss Cornelia E. Thomas, sister of the bridegroom, was the maid of honor, and the bridesmaids were the Misses Elizabeth M. Van Winkle, Juliet Preston Kumler, Grace Thomas, Juliet E. Whiting, Elizabeth B. Brundridge and Louis D. Van Beuren. George H. Southard, Jr., was best man, and the ushers were Mortimer Day, Cornelius Mitchell, Arthur Hamlin, Charles W. Gross, James H. Walker and Myron T. Townsend. Following the ceremony a reception was held at the residence of the bride's mother, Mrs. J. B. Reynolds, 29 W. 14th St. The bride and bridegroom received. Intimate friends and relatives only were invited to the reception.

During the worst of the day's rain storm, about 2.30 P. M., last Wednesday, an accident occurred just in front of the building erecting at 6 Maiden Lane, which attracted a crowd of people. A horse and wagon belonging to J. & W. Fishbaum, truckmen, 20 Maiden Lane, and driven by John Bourne, 241 W. 11th St., was coming toward Broadway and was just behind another vehicle. They stopped to allow a third team to pass, and in some way the horse belonging to the trucking firm fell into a deep hole which had been dug to receive gas mains. The hole was just wide enough to admit the horse, and he lodged therein with only his head above the brink of the hole, in such a position as to be helpless. The police, aided by workmen, rigged a tackle, and using the engine and hoist employed in the construction of the building, started to raise the horse out of the hole. When the neck and fore feet were above ground the rope slipped, but was again adjusted, and the horse was

(New York Notes continued on page 67.)

ESTABLISHED 1852

THE NASSAU BANK

Original Clearing House Member

Corner Nassau and Beekman Streets - - - - NEW YORK

Title Guarantee and Trust Co.

176 Broadway (between John St. and Maiden Lane), New York

Capital and Surplus - - - - \$12,000,000

Deposits received subject to Check. Interest allowed. Letters of Credit issued. Drafts drawn on Great Britain and the Continent. All Banking Facilities afforded to Customers. Accounts of Jewelers are especially solicited.

Finance Committee in Charge of Banking Interests

E. T. BEDFORD, 26 Broadway
 C. H. KELSEY, President
 E. L. MARSTON, of Blair & Co., Bankers
 W. H. NICHOLS, General Chemical Co.

CHARLES A. PEABODY, President Mutual Life Ins. Co.
 JACOB H. SCHIFF, of Kuhn, Loeb & Co.
 JAMES SPEYER, of Speyer & Co.
 E. O. STANLEY, 2d Vice-President

BRANCH BANKING OFFICES: 196 Montague St. and 175 Remsen St., Brooklyn; 350 Fulton St., Jamaica; 67 Jackson Ave., Long Island City

The Market and Fulton National Bank of New York.

ORGANIZED 1852

81-83 FULTON STREET.

Capital, \$1,000,000.

Surplus, \$1,500,000.

PROGRESSIVE — CONSERVATIVE — SUCCESSFUL.

ALEXANDER GILBERT, President.
 R. A. PARKER, - Vice-President.
 T. J. STEVENS - - - Cashier.
 JOHN H. CARR - Asst. Cashier.

Invites the Accounts of Jewelers.Will extend every facility that good banking will justify**SAFE DEPOSIT VAULTS.**

THE STATE BANK

376-378 GRAND STREET, NEW YORK

Capital and Earned Surplus, over \$1,500,000. Deposits over Fifteen Millions.

Offers a favorable market for short and long time jewelry and diamond paper.

The Mercantile National Bank

OF NEW YORK

February 4, 1908

ASSETS

Loans and Discounts	\$6,992,758.84
U. S. Bonds.....	1,009,125.00
Bonds to Secure U. S. Deposits	959,357.50
Real Estate and Securities	1,018,800.00
Due from Banks and Bankers	341,581.72
Exchanges for Clearing House	286,689.24
Cash	1,395,968.50

\$12,004,280.80

LIABILITIES

Capital	\$3,000,000.00
Surplus and Undivided Profits	2,407,236.31
Bank Notes Outstanding	975,000.00
Deposits	5,285,044.49
Bond Account	337,000.00

\$12,004,280.80

SETH M. MILLIKEN, President

MILES M. O'BRIEN, Vice-President

EMIL KLEIN, Cashier

WM. SKINNER, Vice-President

ALFRED W. DAY, Assistant Cashier

GERRISH H. MILLIKEN, Vice-President

DIRECTORS

WILLIAM F. CARLTON,
WILLIAM NELSON CROMWELL,
EDWIN GOULD,
HAROLD A. HATCH,
EDWARD T. JEFFERY,

GERRISH H. MILLIKEN,
BENJAMIN NICOLL,
MILES M. O'BRIEN,
CHARLES E. PERKINS,
DICK S. RAMSAY,
JOHN F. KEHOE,

GEORGE H. SARGENT,
WILLIAM SKINNER,
WILLIAM H. TAYLOR,
WARNER VAN NORDEN,
S. M. MILLIKEN.

Strictly a Commercial Bank
Accounts Solicited

The Chatham National Bank

appreciates the good will of its customers in the jewelry trade. Their co-operation with us in presenting the subject of our facilities to others is most gratifying

SOLD DIRECT TO THE RETAIL TRADE ONLY

FEATURES OF OUR LINE

The UNIQUE, ARTISTIC and UNUSUAL, together with BEST WORKMANSHIP, SUPERIOR QUALITY and PERFECTION IN FINISH



Brooches in gold filled or sterling silver, the gold filled finished in rose or dark green (antique). The sterling in French grey or oxidized. We use finest imitation stones and can furnish any stone or color required.

We Manufacture in GOLD FILLED and STERLING SILVER

BROOCHES, HAT PINS, COMBS, HANDY PINS, WAIST PIN SETS, BARRETTES, SCARF PINS, VEIL PINS, LINKS, BUCKLES, SASH BROOCHES, BRACELETS and NECKLACES.

C. RAY RANDALL & CO., North Attleboro, Mass.

NEW YORK OFFICE, No. 7 Maiden Lane

SAN FRANCISCO OFFICE, Henry M. Abrams Co., No. 717 Market Street

Address all orders and communications to Factory, North Attleboro, Mass.

New York Notes.

(Continued from page 63.)

ally drawn up and swung to a place of safety.

Harry S. Wiltshire, New York representative for Regnell, Bigny & Co., is sick at his home.

The firm of Ludwig Nissen & Co., New York, has been incorporated under the laws of the State of New York with \$600,000 capital stock, all paid in, and with Ludwig Nissen as president.

Benjamin Westervelt, of the New England Watch Co., who was operated upon in 30, as noted in THE CIRCULAR-WEEKLY recently, is improving steadily and will soon be his robust and good natured self again.

The Boost Club has changed the date of the February dinner to Wednesday evening, Feb. 26. The dinner will be at the Iline Association, as usual. The cost is 2.50 a cover, and the gathering is to be formal.

The International Silver Co. has declared quarterly dividend of 1 per cent. on its preferred stock, payable April 1. This is a reduction of one-half of 1 per cent. from the previous disbursement, which was made on Jan. 1 last.

Theodore W. Foster, of Theodore W. Foster & Bro. Co., Providence, was in this city yesterday en route to Ormond Beach, Fla. He will visit other places in Florida and expects to return in about two weeks. He is accompanied by his family.

Rudolph Schrader, who was at one time with the firm of Muss & Schrader, in Maiden Lane, died at his home, 621 Sterling Pl., Brooklyn, last Friday. Funeral services were held Sunday.

Interment Monday morning in Maple Grove Cemetery. Judge Hough, in the United States District Court, has granted a discharge in bankruptcy to Asher Lewine, 208 W. 141st St. A petition in involuntary bankruptcy was filed against Mr. Lewine in October. The liabilities as shown by the schedules are \$17,957.

Mrs. Mary E. Sibley, who died at Bedford City, Va., last week in the 71st year of her age, was the daughter of the late Benjamin W. Clapp, a former well-known manufacturing jeweler of this city. The funeral services were held Monday at Christ Church, Elizabeth, N. J.

The firm of Pitzele & Baschkopf, manufacturers of diamond mountings, 47 Maiden Lane, dissolved Wednesday last by mutual consent. The business was first started in 1898 as Pitzele & Co., and in 1900 changed to the above style. Samuel Pitzele and Henry Baschkopf will both continue business on their own account, the former at 1 Maiden Lane, and the latter at the old address, 47 Maiden Lane.

The Board of United States General Appraisers, in a decision handed down last week, held that watches cannot be sent abroad for repairs and returned free of duty unless the owner makes the usual oath relating to American products sent abroad. The American Express Co., acting for a patron, objected to the action of the collector at Boston in assessing full duty on a watch which had had new works placed

in it in Europe. General Appraiser Hay says in his decision that as there was no compliance with the regulations, the protest must be overruled.

Some damage was done to offices of the L. E. Waterman Co., where a fire started last Saturday afternoon, about 6 p. m., in the building at 10 Courtlandt St., in the lower lofts of which are located a candy store and a picture framing establishment. The offices of the fountain pen company suffered from the effect of water and smoke, but the fire was controlled before the flames spread to the Waterman offices.

A meeting of the creditors of Edwin W. Dayton, 4 W. 39th St., against whom a petition in bankruptcy was filed some time ago, was held at the office of William Allen, referee in bankruptcy, 67 Wall St., Monday, at which time John A. Dutton, the receiver, was elected trustee. A short examination of Mr. Dayton was held relative to the schedules in bankruptcy which have been filed. The meeting was adjourned until March 2.

Amedee Spadone, a prominent rubber merchant, who died Saturday at his residence, 270 West End Ave., of pneumonia, was for many years a prominent member in the jewelry trade of New York. Mr. Spadone, who was 81 years old, early in life entered the jewelry line and for years was prominent in the jobbing business. In the late 60's he was a member of the firm of Warren & Spadone in business at 4 Maiden Lane and later a member of the firm of Spadone, Rood & Co., at 658 Broadway, his partner being Charles D. Rood, now of the Hamilton Watch Co. About 30 years ago Mr. Spadone retired from the jewelry trade to enter the rubber business and became one of the leading merchants in that line. The funeral services, which were held at 11 o'clock Monday morning, were conducted at Christ Church, Broadway and 71st St. The interment was private. The deceased is survived by a widow and four children.

Sol Lindenborn, New York, Offers Creditors a Settlement at 60 Per Cent.

Sol Lindenborn, one of the largest importers of diamonds, 2 Maiden Lane, New York, has made an offer of settlement to his creditors. It is said to be a composition at 60 cents on the dollar, this amount to be payable in notes due in four, eight and 12 months. It is said that there are a few creditors. So far as can be learned no statement has been made public as to the assets and liabilities.

I. Moritz, an European creditor, is now in New York to arrange the matter for the European creditors. Mr. Lindenborn, who is widely known and popular in the trade, has the sympathy of his friends because of his financial trouble.

Mr. Lindenborn commenced business in the Spring of 1887.

The store of W. E. Davis, Nelson, Pa., was recently entered by burglars, who stole about \$170 worth of stock. Two men who gave their names as Daniel Ayres and James McFilio, respectively, were captured later at Lawrence, accused of the crime.

Last Week's New York Arrivals

THE CIRCULAR-WEEKLY each day posts in its office a bulletin of the latest buyers visiting New York, which every member of the trade is cordially invited to copy.

AKRON, O., F. B. Goodman (M. O'Neill & Co.), 458 Broadway.
ALTOONA, PA., J. A. Baird (Kline Bros.), Breslin, 214 Church St.
AUGUSTA, GA., Miss M. D. George (J. B. White & Co.), 214 Church St.
BOSTON, MASS., H. J. Belcher (Jordan, Marsh & Co.), 34 Union Sq.
BRIDGEPORT, CONN., J. C. Mizer (Howland Dry Goods Co.), Park Ave.
CHICAGO, R. J. Goldsmith (M. Herman & Goldsmith), Albert.
DENVER, COLO., H. Holmes (Denver Dry Goods Co.), Broztell.
KANSAS CITY, MO., E. L. Chamberlain (Jones Dry Goods Co.), Grand.
LOUISVILLE, KY., J. F. Ramp (J. Bacon & Sons), 214 Church St.
PORT JERVIS, N. Y., H. J. Pippitt, St. Denis.
SAN FRANCISCO, CAL., Judis Alphonse (Judis Alphonse Co.), L. & M. Kahn & Co., 170 Broadway.
WASHINGTON, D. C., J. Hertzberg (S. Kann Sons & Co.), Imperial 621 Broadway.

Newark.

Nachman Feinschmidt, a jeweler, of 60 Livingston St., was complainant against Valentine Buhl, Gustave Klein and Harry McCauley, all 13 years of age, in the Fourth Precinct Police Court last week. The trio were charged with the larceny of 10 watch cases valued at 30 cents each, and two others valued at \$2 each. The complainant alleged the boys managed to gain an entrance into his store through a transom.

A petition in bankruptcy was filed recently against Lewis Camm and Carsom Berntheizel, jewelry manufacturers at 160 Ferry St. It is alleged that part of the stock valued at \$15,000 was removed from the factory for the purpose of giving a preference to certain creditors. Upon the application of Jacob L. Newman, attorney for the petitioning creditors, the court ordered the return of these goods and this was done. The petitioners also called attention to a suit brought by the American Exchange National Bank on notes for \$2,000. Albert Haefel, assistant cashier of the Union National Bank, has been appointed receiver of the jewelry firm. He says that the liabilities, amounting to \$12,000, will all be liquidated.

Policeman John F. Weber, who killed Frank Ides, an escaped convict, while the latter was trying to elude arrest in Newark early Saturday morning, was taken before Judge Ten Eyck Monday morning and charged with manslaughter. Capt. Ryan, his commander, will make the complaint. Former State Senator Michael T. Barrett volunteered his services without pay and said he would give whatever bail was necessary. Grover Edwards, Robert Cameron and Charles Henderson, who were with Ides when he was shot, admitted, the police say, that they went to Newark on Friday night to rob the store of L. F. Weick & Co. at 10 Pacific St., but found two policemen standing in front of the store.

MR. OPTICIAN: Our new catalog is ready for distribution—it will be found of real interest to you. Will send you a copy free—if you will tell us who and where you are. Ask for Catalog "O." Address

WILLIAM DIXON, INCORPORATED, 39 JOHN STREET, NEW YORK.
Formerly F. W. GESSWEIN COMPANY.

THEBERATH & CO., Inc.

Manufacturers of unusual, exclusive and salable designs in 14k. gold

**Brooches, Festoons, Handy Pins,
Barrettes, Pendants, Veil Pins,**

in beautiful plain patterns, or set with precious and semi-precious stones.

KENT & WOODLAND, SELLING AGENTS

12 John Street,

NEW YORK CITY



NECKLACE No. 540

Lapis,
Amethyst,
Quartz,
Spanish Topaz,
Amazonite.

Price, \$4.50

Illustration half size

**Hand Made
Sterling Silver
Real Stones**

INNUMERABLE DESIGNS

CORAL CAMEOS—NECKLACES

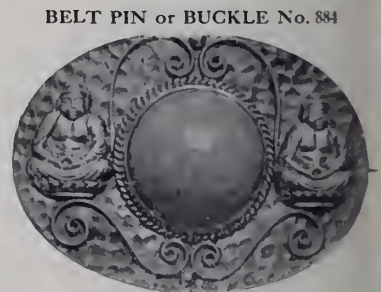

BELT PIN or BUCKLE No. 884

Lapis, Amazonite, Spanish Topaz,
Amethyst. Price, \$4.00

VAN DUSEN & STOKES CO.

1123 Chestnut Street, PHILADELPHIA, PA.

Tel. 4457 }
4458 } Cort.

JOHN M. RICHARD

2 MAIDEN LANE
Room 302, NEW YORK

American Pearls and Baroques

MATCHED PAIRS FOR EARRINGS

The Largest and Finest Assortment in the Market, Mounted and Unmounted.

Learn Watchmaking

Refined, profitable labor. Competent men always in demand. We teach it thoroughly in as many months as it formerly took years. Does away with tedious apprenticeship. Money earned while studying. Positions secured. Easy terms. See for catalogue. Address

St. Louis Watchmaking School, St. Louis, Mo.

RUDOLPH NOEL

PHILIP NOEL

RUDOLPH NOEL & CO.

IMPORTERS AND CUTTERS OF DIAMONDS

2 Tulp Straat, AMSTERDAM

37-39 Maiden Lane, NEW YORK

Connecticut.

Robert M. Wilcox and his wife are enjoying a sojourn in Honolulu.

Major Wm. H. Lyon, Meriden, has been elected fourth vice-president of the Connecticut State Fair Association.

The steel department of R. Wallace & Sons Mfg. Co., Wallingford, is working on 60-hour per week schedule.

Wm. E. Sessions, accompanied by his son, Kenneth, left, Feb. 15, for Sarasota, Fla., where they will remain until about March 1.

B. Elliott Smith, optician with E. J. Brown, 214 Asylum St., Hartford, was married, Feb. 18, to Miss Margaret Schurman, Dorchester, Mass.

George H. Wilcox, president of the International Silver Co., has just returned from a business trip to Toronto and Hamilton, Ont., and Chicago.

B. B. May, traveling representative for International Silver Co., Wallingford, left Tuesday, of last week, on a five weeks' trip through the south.

President F. A. Wallace conducted a Republican rally in Wallingford, Feb. 16, and introduced the speakers, Congressman Lilly, of Connecticut, and State Representative Charles H. Tibbits delivered addresses.

Silver bars, valued at \$1,000, were stolen from the plating room in the factory of Landers, Frary & Clark, New Britain, about a week ago. The metal weighed about 100 pounds and consisted of 50 plates 12 inches long by eight inches wide.

Andrew Dehm, who for 40 years had been in the employ of the Charles Parker Co., Meriden, died suddenly, Feb. 13, at his home at that place, aged 65 years. Death was caused by apoplexy. The deceased had been a resident of Meriden for over 50 years.

Samuel Sloane, general foreman of the Waterbury Clock Co.'s factory, Waterbury, and Miss Julia McCormick, an employe of the same concern, were united in matrimony, on Monday, of last week. The couple left on a wedding trip to Washington, D. C. Upon their return they will reside at 295 Main St.

The handsome clock which the Second company, Governor's Foot Guard, presented to the Richmond Light Infantry Regiment recently, was made by the New Haven Clock Co., New Haven. The case is of the Colonial design and stands nearly eight feet high. It is made of mahogany and is hand-carved.

A special meeting of the stockholders of the New England Watch Co., Waterbury, was called Feb. 24 and ratified the recommendations of the directors that the capital stock of the company be increased from 50,000 to \$1,000,000. The new stock is to be preferred and will bear cumulative dividends at the rate of seven per cent.

The New England Watch Co. has wanted to its employes one hour and a half for lunch instead of the usual hour. By this arrangement many who are now obliged to use the trolley cars both to and from home in order to return within the hour limit, will be enabled to walk. The employes are unanimous in expressing their appreciation of the grant of the extra half hour.

At the annual meeting of the Landers, Frary & Clark Mutual Aid Association, held Feb. 17, in New Britain, the following officers were elected: President, A. G. Anderson; vice-president, J. W. Page; secretary, Thomas W. Timbrell; treasurer, J. H. Smith. The auditors are E. Weyh, J. Baumgartner and Edward Hallorn, the latter having succeeded B. F. Hall. The amount of benefits which have been paid out during the past year is \$2,131, the largest amount since the association was organized.

During the recent meeting in Meriden of the local Aerie of Eagles, a number of donations were received for the coming charity carnival. Among the donors are President Wilcox, president of the International Silver Co., who gave a five-piece silver tea set; the Bradley & Hubbard Mfg. Co., a table lamp; the C. F. Monroe Co., a costly cut glass dish; Manning, Bowman & Co., a pearl agate teapot and bread mixer; Wm. Rogers & Sons Co., 25 pieces of flat ware; E. A. Bliss Co., a bag, bar and comb, and the J. J. Niland Co., which contributed cut glass.

Canada Notes.

F. B. Hostetler, Streetsville, Ont., has sold out.

The firm of Whcatley Bros., Regina, has dissolved.

A. E. Kerr, Edmonton, Alta., has assigned to S. H. Smith.

A meeting of the creditors of F. W. Stansall, Montreal, was held recently.

The stock of J. W. Fraser, Russell, Man., has been sold by the bailiff to Campbell Bros.

A meeting of the creditors of W. W. Tyrill, St. Catharines, was announced for Feb. 21.

Tufts Bros., Fairfax, Man., have dissolved partnership, R. Tufts continuing the business.

The marriage of J. R. Wendt, Wroxeter, Ont., son of Charles Wendt, Mildway, Ont., to Miss Mary K. Robinson, Wroxeter, will take place to-day, Feb. 26.

Phillip Henry Jenkins, Sr., head of the firm of B. M. & T. Jenkins, dealers in antique furniture, Montreal and Toronto, died recently in his 61st year.

Three young burglars, Henry Brennan, Harold Milks and Harry Sadler, have confessed in the Montreal courts to stealing from the silver plating works of George A. Gray.

Out-of-town jewelers calling on the Toronto, Ont., trade last week included W. H. Smith and Wm. Busby, Oakville; T. C. Watson, Newmarket, and F. E. Sheppard, Paisley, all Ontario.

Stolen silver goods, jewelry, and other articles valued at \$2,000 were traced to the store of David Miller, Montreal. He has been arrested on a charge of unlawfully receiving stolen property.

William F. Mannick, wanted by the New York police on a charge of stealing \$1,200 worth of jewelry from Tiffany & Co., New York, is under remand in Montreal awaiting the arrival of documents from the United States.

L. Herbert Luke, of Ambrose Kent & Sons, Ltd., who at the last meeting of the

Grand Chapter R. A. M., in Toronto, Ont., in January, was appointed to the office of Grand Standard Bearer, was, Feb. 12, presented by his Chapter with a set of regalia suitable to his rank.

On the evening of Monday, Feb. 17, a banquet was given by Principal Playnter, of the Canadian Horological Institute, in commemoration of the official opening of the new Institute building at the corner of Church and Wellesley Sts., Toronto, Ont. About 160 guests were present.

Isaac Cohen, of the firm of Sloves & Cohen, Bleury St., Montreal, has been arrested on a warrant charging him with obtaining goods by fraud. He pleaded not guilty and has been liberated on bail bonds of \$800. The firm went into liquidation a few weeks ago and the assets have just been sold.

Samuel Finkle, 23 years old, who has been in Canada about two years, was arrested in Toronto, Ont., on Wednesday last on charges of arson, perjury and subornation of perjury. About two months ago he started a small jewelry manufacturing business at 252 Elizabeth St., Charles Goodman, with whom he had worked, advancing him \$100 for stock and tools, on which Finkle took out a policy for \$1,000 with the London Insurance Corporation. A fire occurred Jan. 25 and Finkle made up a list of losses amounting to \$1,200. The insurance company employed a detective, who found the walls of the place bored with holes and smelling strongly of coal oil, and on examining the debris found little of value. Finkle charged Goodman, who testified to the real character of the stock, with conspiring with the company to defraud him, and induced Harry Green, a young man in his employ, to swear to a statement that Goodman had induced him (Green) to steal from Finkle's stock a lathe included in the list of articles on account of which a claim was made and to pawn the same as a means of invalidating Finkle's case. Green, on being questioned by the detectives, admitted that his declaration was a fabrication that he was incited to make by Finkle. Green was held as a material witness.

New Stores and Enterprises.

W. F. Hart will open a large store about March 1 at Franklin, Va.

Jas. H. Carey, formerly of Detroit, Mich., has gone to Dallas, Tex., to engage in business on his own account.

I. Goddon, St. Paul, Minn., will open a general store in Buffalo Lake, Minn., in the Spring. He will carry a line of jewelry.

The Stead Lens Co. has been incorporated in Kansas City, Mo., with a capital stock of \$50,000, by S. W. Noggle, W. J. Lowe and John N. Orr.

Melville M. Wells and Ralph C. Wells, sons of Chester H. Wells, have started in business at 407 Market St., Wilmington, Del., as engravers and manufacturing jewelers and opticians.

Charles F. Warner, Two Harbors, Minn., is closing out his stock.

Burnett Bros., who have jewelry stores in Seattle, Chehalis, Centralia and Aberdeen, Wash., have filed articles of incorporation, with a capital stock of \$150,000.



Here are some of the publications that are carrying the facts about the HOWARD Watch into the homes of every city and town in the United States.

A wide-awake Retail Jeweler in the Middle West writes the Howard factory, "I believe every man in this town who reads the English language takes one of the magazines containing the Howard advertising.

"I am using this fact for my own benefit, and I have sold more fine watches in the past six months than in any half-year since I started in business. I let everybody know that my store is headquarters for the Howard; that I am 'the Howard dealer' your ads. refer to."

It is easy to sell the Howard Watch. It has sixty years' reputation back of it. It is the oldest and yet the most modern watch. It has kept pace with progress. It is the finest watch in America to-day—as it was in 1842.

E. HOWARD WATCH COMPANY
BOSTON, MASSACHUSETTS.



The Howard Watch

Tourists and travelers take the Howard Watch to all parts of the world.

The man of leisure carries it because it is the finest practical timepiece that money will buy.

How much more important it is to the scientist, the expert, the skilled mechanic—the man whose work requires precision and accuracy.

Lieutenant Peary in his exploration of the Arctic Region relies solely upon the Howard. It is adjusted to temperature, withstanding heat and cold, vibration and change of position.

Thousands of other men take pride in its admirable mechanism and satisfaction in its timekeeping exactness.

The Howard is unique as a watch investment. If you want to know how good, try to buy one at second-hand. The output is limited. It is handled only by the most reliable jewelers. The Howard dealer in every town is a good man to know.

The price of each HOWARD watch—from the 17 jewel, 25-year filled cases at \$35, to the 23 jewel, extra heavy cases at \$150—is fixed at the factory, and a printed ticket attached. Find the right jeweler in your locality and ask him to show you a HOWARD—learn why it is more highly regarded than any other watch and why there is distinction in carrying it.

Elbert Hubbard visited the home of the HOWARD Watch and wrote a book about it. If you'd like to read this little journey, drop us a postal card—Dept. A—we'll be glad to send it to you. Also a little catalogue and price-list, with illustrations actual size—of great value to the watch buyer.

E. HOWARD WATCH COMPANY

BOSTON, MASSACHUSETTS

The above announcement appears in the leading magazines and periodicals for February. It reaches 7,500,000 subscribers about 30,000,000 readers. It will be seen by every man in your community who can afford to buy a watch. Some of them will be interested. Are you a HOWARD dealer? Do the people of your locality know they can find the HOWARD at your store?



A. E. GATES

Jewelers' Auctioneer

1 Maiden Lane, New York

Just closed a very successful 10 days' sale for Jeffe Jewelry Co., Birmingham, Ala. Every day's business more than doubled. Without a doubt the most successful sale ever held in Birmingham. If you doubt this, write to the jewelers themselves. For open time, write or wire at my expense.



HENRY C. HASKELL
DESIGNER AND MAKER

FINE GOLD JEWELRY

Has Moved to 38-40 West 33d Street, New York

FORMERLY AT
9-13 MAIDEN LANE

Exclusive Designs, with Estimates, cheerfully furnished for
Special Orders, will have prompt and careful attention.

Recently Published

Gems and Precious Stones

Their Characteristics, Localities of Production
Tests and Some Current Literature

Cloth, Postpaid, \$1.00

Published by
THE JEWELERS' CIRCULAR PUB. CO.
11 John Street, New York

VARISCITE SOHN & HYMAN

Sole Agents

47-49 MAIDEN LANE
NEW YORK

The Newest Stone for High Class Jewelry

LOUIS FELDENHEIMER

Importer and Cutter of

PRECIOUS STONES AND PEARLS

41 MAIDEN LANE

NEW YORK

William G. Morstrom & Co.

DIAMOND IMPORTERS and MANUFACTURING JEWELERS

Memorandum Packages of Loose or Mounted Stones on request. We solicit Special Order Work.

78-80 STATE STREET

CHICAGO, ILL.

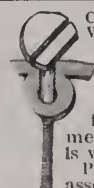

Case Screw Washer **URICH PERFECT FITTING**
Case Screw Washer

Easily adjusted and holds the movement securely even when case shoulder is worn away.

Prices: Gross, \$1.50; Package, 4 doz. assorted, 50c; single doz., 15c.

For sale at all material houses or direct

J.S. URICH, P. O. Box 1942, New York City

TRADE-MARKS

OF THE JEWELRY AND KINDRED TRADES.
Over 4,000 Marks. Second Edition. Price, \$3.00.
The Jewelers' Circular Pub. Co., 11 John St., N. Y.



Mr. Wells, of the Waltham Watch Co., is expected in San Francisco, Cal., in a few days.

Carl Plate, with J. A. Young & Co., San Francisco, Cal., is starting for a long trip to the north. L. E. Price has just returned to the San Francisco office after his first trip for the Duerber-Hampden Watch Works.

H. P. Adams, Pacific Coast agent for the Marin-Copeland Co., has just returned to San Francisco, Cal., from his northwestern trip.

H. A. Forbes, Pacific Coast agent for the Duerber-Hampden Watch Works, is in San Francisco, Cal., preparing for his southern trip.

Among the traveling representatives in Los Angeles, Cal., last week, were: O. Child, Kohn & Co.; Mr. Riley, Mandeville, Carrow & Crane; David Schwab, Ciner & Seclaman.

The following traveling representatives called in the trade in Kansas City, Mo., last week: John Lucas, National Jewelry Co.; Lee Frank, Buffalo Jewelry Co.; B. Hyman, Hirsh & Hyman.

Traveling representatives who visited Denver, Colo., recently included: William Adams, International Silver Co.; Mr. Torrent, Mauer Mfg. Co.; David Feiss, Ingomar, Goldsmith & Co.

Among the traveling representatives in Toronto, Ont., recently, were: Arthur Mondon, Ernst Gideon Eck (Pforzheim, Germany); Mr. Robertson, Peers Jewelry Mfg. Co.; J. Lichtenfels, United States Smelting & Refining Works; a representative of L. & M. Wollstein; a representative of Henry Rogers & Son (Birmingham, Eng.); J. R. Grant, Wm. Hutton & Son (Sheffield, Eng.).

Among the traveling representatives who called in the trade in St. Louis, Mo., last week, were: Jacob Schorsch, Emrich, King & Schorsch; Walter Noon, Cory Bros. Co.; Wallace E. Welch, Hoyt, Obrig & Geiger Co.; Jack Thompson, J. B. Bowen & Co.; E. A. Reed, Reed & Barton; Charles L. Sexton, William L. Sexton & Co.; Zach. A. Oppenheimer; Joseph J. Sideman, Redlich & Co.

The following traveling representatives were in Lancaster, Pa., recently: C. S. Fake, Whiting Mfg. Co.; Mr. Swan, Sinclair & Co.; L. E. Picard, American Watch Case Co.; Morris Weil, S. L. Lynch, Wm. B. Kerr Co.; H. C. Berdan, Gorham & Co.; Jos. Fagan, Unger Bros.; Mr. Theobald, J. Joare & Co.; Mr. Walby, Wolfsheim & Sachs; C. E. Walker, Pairpoint Corporation; B. J. Clark, La Pierre Mfg. Co.; John P. Melhado, Melhado & Hottenfels; S. H. Lynch, Wm. B. Kerr Co.; Lipman E. Picard, American Watch Case Co.; A. H. Abell, S. Sternau & Co.; Edwin A. Starn, H. M. Smith & Co.; D. A. Burt, R. Wallace & Sons Mfg. Co.; Alex. Conklin, Edward Todd & Co.; M. H. Mason, James E. Blake Co.

Traveling representatives who called on the Cincinnati, O., trade during the past week included: H. Dellerson, Henry E. Oppenheimer & Co.; H. E. Barkman, Simpson, Hall, Miller & Co.; Charles L. Sexton, William L. Sexton & Co.; Walter S. Noon, Cory Bros. Co.; Wallace E. Welch, Hoyt, Obrig & Geiger Co.; Jules Franklin; Arthur Totten, Sansbury & Nellis; H. D. Meyer, J. N. Deitsch; E. S. Fishback, Hamilton Watch Co.; Mr. Chisholm, Bugbee & Niles Co.; Fred Somes, Pates & Bacon; Thomas K. Benton, G. W. Parks Co.; Frank Whiting, Whiting & Davis; Jacob Schorsch, Emrich, King & Schorsch; Walter R. Shute, Day, Clark & Co.; F. E. Wiske, Rogers Silver Plate Co.

Traveling representatives who called on the trade in Omaha, Nebr., during the past week, included: Joseph Leudan, A. R. Katz & Leudan Co.; David Beer, Bernheim & Beer; S. W. Abbey, E. Ira Richards & Co.; F. R. Horton, Carter, Howe & Co.; Leo Cahn, Borrelli & Vitelli; Chas. E. Eckel, Unger Bros.; Mr. Lucas, Frank W. Smith Co.; James P. Bannar, D. Gruen, Sons & Co.; Alfred Goldsmith, Adolph Goldsmith & Son; I. Price, Louis Strasburger's Son & Co.; L. M. Frank, Buffalo Jewelry Case Co.; Geo. W. Birnbaum, Julius Wodiska; Mr. Barker, Warren & Williams; C. A. Weidemann, Geo. Borgfeldt & Co.; Mr. Gorman, Woodside Sterling Co.; Samuel L.

Griffin, Langfeld Bros. & Co.; Geo. F. Heidet, C. F. Rump & Sons; H. F. Hines, Wm. Weidlich & Bro.; J. E. Austin, Handel Co.; Frederick C. Kopf, Powers & Mayer; J. H. Johannot, Sterling Glass Co.; Jno. O. Slemmons, J. B. Bowden & Co.; E. E. Richards, Rogers Silver Plate Co.; R. E. Williams, St. Louis Silver Plate Co.; W. A. Moore, William Dixon, Inc.; Chas. H. Ide, Farmington Mfg. Co.; W. Barker, R. Wallace & Sons Mfg. Co.

The following traveling representatives visited Pittsburg, Pa., during the last week: H. A. Bliss, Wordley, Allsopp & Bliss Co.; E. P. Tiffany, F. H. Sadler Co.; J. J. Sideman, Redlich & Co.; Walter R. Shute, Day, Clark & Co.; L. E. Picard, American Watch Case Co.; George A. Jochum, C. Cornelsen; A. E. Silberman, Adolphe Schwoh; A. B. Randall, Codding & Heilborn Co.; F. E. Jacobus, Bride & Tinckler; H. W. Raymond, Worthington & Raymond; Jacob Schorsch, Emrich, King & Schorsch; Charles B. Burgess, Frank W. Whiting & Co.; H. B. Bliss, Gorham Co.; E. A. Reed, Reed & Barton; J. F. Dean, Reed & Barton; Mr. Crane, Mandeville, Carrow & Crane; Harry Goodison, E. G. Webster & Son; Charles T. Dougherty, Osmer-Dougherty Co.; W. H. Gregory, Strobell & Crane; Mr. Rogers, Rogers & Co.; Fred T. Barry, J. A. & S. W. Granbery; W. M. Rosenberger, A. Wallach & Co.; J. W. McClannin, Wilcox Silver Plate Co.; A. J. Sherrard, Enos Richardson & Co.; Gus S. Melville, D. Wilcox & Co.; D. A. Davidson, Wallach & Davidson; Arthur Totten, Sansbury & Nellis; Harry B. Kenning, Park Bros. & Rogers; P. A. Wilkinson, J. J. Sommer & Co.; John F. Schierloh, Keystone Watch Case Co.

Charles W. Hadley, Seattle, Wash., Makes an Assignment to Jos. Mayer & Bro.

SEATTLE, Wash., Feb. 22.—Charles W. Hadley, of this city, has made an assignment to Jos. Mayer & Bro., of this city. His liabilities are about \$7,000 and his assets about the same amount. He is offering 60 cents on the dollar in settlement to his creditors.

Mr. Hadley began business on his own account in 1907. Previous to that time he was employed for some years as a window trimmer.

Baltimore.

The window in Aug. Thurn's store, at 848 S. Eutaw St., was broken open one night recently and several watches and small articles were stolen.

Harris Cohen, 123½ South High St., has been committed for court for receiving stolen goods in connection with the charge of the larceny of two diamond rings against Julius Lieberman.

The wife of Edward W. Oppenheimer, of the firm of M. J. Oppenheimer & Sons, was attacked by a negro one night recently while walking along the street. The negro was frightened away.

Arthur Wallenhorst has been made happy by the return of his pet terrier, "Dixie," that had strayed from him a month ago. Mr. Wallenhorst has had the little black and tan for 10 years, and during that time they have been inseparable, they having traveled together and being constantly at the store. The finder refused the reward of \$100 offered by the jeweler, but Mr. Wallenhorst sent the finder's wife one of the finest gold bracelets in his show cases.

The Maryland Retail Jewelers' Association recently held a meeting at the Merchants and Manufacturers' Association's rooms, adopting a number of resolutions, among them one indorsing the enforcement of the national law requiring the stamping

of the quality on gold and silver, which went into effect June 1, 1907. It was also resolved by the association to incorporate and affiliate with the American National Retail Jewelers' Association. The meeting was largely attended, and numerous speeches were made on subjects of interest to the trade.

Cleveland.

Wilbur L. Cook, the genial Keystone representative who lately transferred his affections to the E. Howard Watch Co., called on the trade during the last week.

J. M. Martin, Crestline, O., who is quite an automobile enthusiast, was in this city during the past week taking in the show and looking for the latest ideas in automobile construction.

The Chamber of Commerce is very busy with preparations for the care and entertainment of the convention of the National Educational Society to be held in this city next Summer. Webb C. Ball is a member of the committee on publicity, while Capt. R. E. Burdick is to help the committee on badges with his practical knowledge of the subject.

H. W. Beattie, whose diamond displays are always a feature of interest about the Euclid Ave. Arcade, had a particularly good arrangement during this week of the local Automobile Show. A good-sized toy "auto" was displayed, its tonneau filled with diamonds, a two-carat pair for searchlights, and the foreground sparkling with stones to represent the glare from the "lights."

A very interesting and helpful article headed "Diamonds—More Precious Than Ever," has just appeared in the supplement of the Sunday edition of a local paper. An accurate description of the methods of production, distribution, etc., is followed by complete reports of interviews with Capt. R. E. Burdick and H. W. Beattie. The matter covered an entire page and will certainly give the general public to understand that prices will be maintained as well as the reasons why.

Word comes from Saginaw, Mich., to the effect that some of the many actions growing out of purchases from the Puritan Mfg. Co. and other concerns of Iowa City, Ia., have resulted in verdicts for the defendants. In the suits in question the plaintiff was one Joseph Stouffer, of Iowa City, Ia., who claimed to be an innocent purchaser of negotiable paper given to the Puritan and other companies by jewelers in payment for goods which they were induced to take. In two such cases in Saginaw depositions were introduced in evidence to show that Stouffer was not what he claimed to be, but was, in fact, associated or connected with the concerns in question, and a verdict for the defendants in the Circuit Court has been affirmed by the Supreme Court. Thomas G. Baillie, the attorney who defended these suits, has in his possession the deposition taken in the cases, which he says he will be glad to submit to attorneys having suits of a similar kind pending, as in every case in which they have been used so far, he claims the defendants have been successful.



ENTERPRISING and successful jewelers everywhere are pushing the sale of some individual line of watches which they believe to be superior to all others, and upon which they can also make a satisfactory and justifiable profit.

This explains the growing demand for **ILLINOIS WATCHES**, in 0, 12, 16 and 18 sizes, by increasing numbers of leading jewelers throughout the United States.

If you are not familiar with the superior quality of—and advantages gained by handling—Illinois Watches, it will mean reputation and dollars for you to investigate.

Every one fully guaranteed.

Price List sent on application.

ILLINOIS WATCH COMPANY

SPRINGFIELD

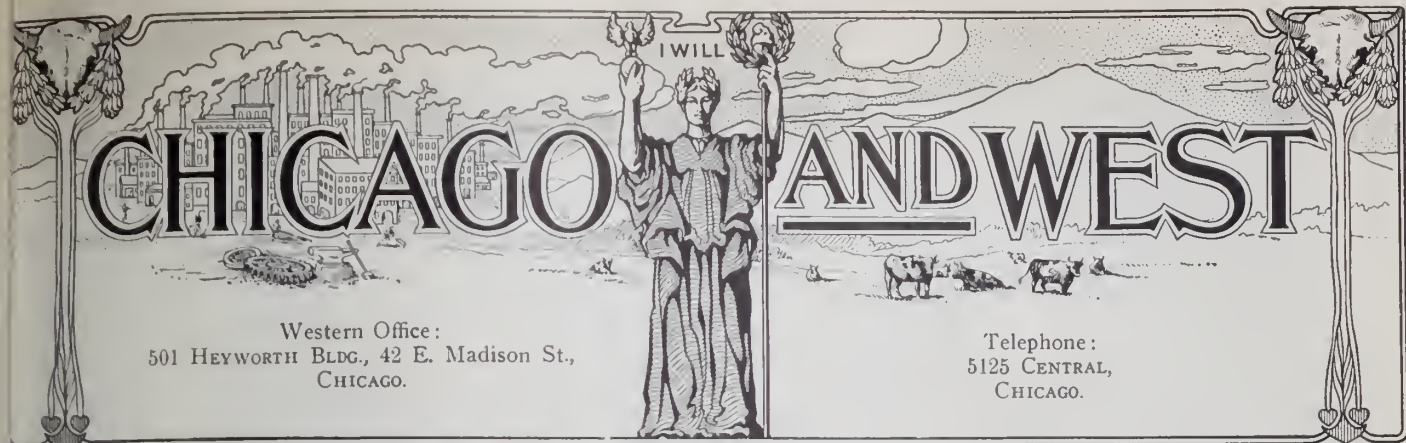

Western Office:
501 HEYWORTH BLDG., 42 E. Madison St.,
CHICAGO.

Telephone:
5125 CENTRAL,
CHICAGO.

Chicago Notes.

L. H. Schafer visited Detroit last week. M. A. Mead is taking a vacation in Florida.

A. C. Becken is on a visit to the eastern factories.

C. E. Child is on a trip to Kansas and Colorado.

G. S. Titus has returned from a trip to the northwest.

Roll Church has returned from a trip to the northwest.

G. F. Schinermund, Greenville, O., was here last week buying stock.

H. J. Crawford, Marseilles, Ill., was here last week accompanied by his son.

Harry H. Miller is back from a trip to the factory of Hutchison & Huestis.

C. B. Warne, of Swartz & Warne, Redfield, S. Dak., was a visitor here last week.

H. F. Hahn, E. J. Hahn and Mrs. E. J. Hahn are spending a few weeks at Pass Christian, Miss.

Mr. Cannon, formerly ribbon buyer, is now buying for the jewelry department of Carson, Pirie, Scott & Co.

Roll Church, J. W. Tice, and F. Lutz were unanimously elected members of the "Camels" at the last meeting.

Benj. Allen and B. C. Allen, accompanied by their families, left last week for a month's trip to Southern California.

Benj. Allen & Co. will remove their tool and material department to the fourth floor of the Silversmiths' building May 1.

Dan Philas, with B. A. Ballou & Co.; Fred Perry, with F. H. Sadler Co., and Louis Blackinton, were here last week.

W. A. Fay has returned from a trip to the Pacific coast. Mr. Fay's wife and son will remain in Los Angeles until June.

No equity for the creditors can be found in the estate of Theo. Leaf, retail jeweler at DeKalb, Ill., who failed some time ago.

Harry E. Biggins, of the Biggins-Rodgers Co., paid a visit last week to the Chicago representative of the concern, Geo. E. Smalley.

J. Howard Fry, of the Fry Cut Glass Co., Rochester, Pa., was here last week visiting F. B. Tinker, the Chicago representative of the firm.

News was received here that L. A. Soper, Harvard, Nebr., had failed. The liabilities are said to be \$2,500 with assets of the same figures.

Harry T. Jack, optician in the Masonic Temple, was, last week, elected president

of the Alumni of the Northern Illinois College of Ophthalmology.

M. L. Jalonack and H. E. Glendore, jewelry auctioneers, have returned from Pittsburg, Kans., where they conducted a successful sale for H. L. Morrison.

The Chicago offices of the Illinois Watch Case Co. and the Rockford Watch Co. will remove on May 1 from the Silversmiths' building to the ninth floor of the Heyworth building.

Bach & Co., proprietors of the Calumet Watch Co., will move into rooms 300 and 301, Heyworth building, about March 1. They will occupy double the space they formerly had.

The stork recently paid a visit to two members of the Chicago office of Robbins & Appleton, and left a boy at the homes of Jas. J. O'Grady, the cashier, and Burt L. Brown, of the material department.

L. E. Fay, with the R. F. Simmons Co., returned from the coast last week to take the remains of his father east for interment at Northboro, Mass. Mr. Fay, Sr., was 88 years old at the time of his death.

Oscar Wurlitzer, retail jeweler, 639 N. Ciark St., who was recently held up at the point of a revolver and forced to give up \$500 worth of jewelry, fortunately carried a "hold-up" insurance policy, and last week recovered the full amount of his loss.

George Armstrong, formerly with the Mauser Mfg. Co., has secured the line of the Paye & Baker Mfg. Co. and is now on an eight weeks' trip through the Middle West. When in Chicago Mr. Armstrong will show his line at the Palmer House.

The case of Ike Lazarus, arrested for stealing jewelry from Emil Braude & Bro., and of Nathan Vogel, retail jeweler at 316 W. 12th St., arrested for having purchased some of the jewelry, both of whom have confessed to the charges, has been postponed until this week.

The estate of Geo. A. Camp, a retail jeweler at 1248 E. 75th St., who filed a voluntary petition in bankruptcy some time ago, has been found to contain nothing for the creditors. The liabilities are \$3,000 and the assets not more than the \$400 allowed by law to the bankrupts.

The "Camels" met last Thursday at Gallis' with Harry Jones in the chair. The club is in a very prosperous financial condition. One of the features of the meeting was a discourse on the jewelry business by Sol Hess. The next meeting will be held on March 19.

Among the out-of-town jewelers in Chicago last week not previously mentioned, were: Bob Nicoll, Kenosha, Wis.; Arthur Rovelstad, Elgin, Ill.; John Elgin, Keokuk, Ia.; W. J. Graff, Boscobel, Wis.; Louis Ratzesberger, Milford, Ill.; Percy Jackson, Rockford, Ill.; R. A. Woodward, Sandwich, Ill.

At a meeting of the creditors of the Madsen-Steele Co., held last week, it was decided to grant the corporation an extension of credit on the following terms: 20 per cent. cash—five per cent. a month until Jan. 1, 1909, when 20 per cent. cash will be paid, and five per cent. a month thereafter until the accounts are paid.

Local Union No. 18 of the jewelry workers was recently suspended from membership in the Chicago Federation of Labor until it complies with the laws of the central body governing the use of labels. It was charged that the jewelry workers were permitting the use of their label on buttons and badges that were made under unfair conditions.

By an error a note in this column recently stated that Fred Rusch, 420 Oak St., would retire from business May 1. Mr. Rusch says that this is not true, and that the only retiring that he will do is from the road, as his business is growing so large to compel him to quit traveling after 15 years of this work. He will hereafter do all his out of town business by mail.

Anton Serewicz, better known as "Tony," Chicago representative of the Dueber-Hampden Watch Works, will sail, March 3, on the steamer *Kaiser Wilhelm II*, for a three months' trip to Europe. Mr. Serewicz has been in the employ of the Dueber-Hampden companies since 1877, starting as office boy in the Chicago office. As a reward for his faithful and efficient services, which have extended over a period of 31 years, the Dueber-Hampden companies have planned a three months' trip for Mr. Serewicz, which includes a visit to England, France, Switzerland, Belgium, Germany, Austria-Hungary, Denmark, Holland and Russia.

S. Levy, who conducted a store at 618 New Market St., Philadelphia, Pa., has retired from business and requests all those having claims against him and those who owe him money to adjust their accounts with him at the earliest possible moment. Mr. Levy was formerly of Zeitlen & Levy, in the jobbing business at 58 Maiden Lane, New York.

AN ECHO FROM THE FAR WEST--READ THE LETTER

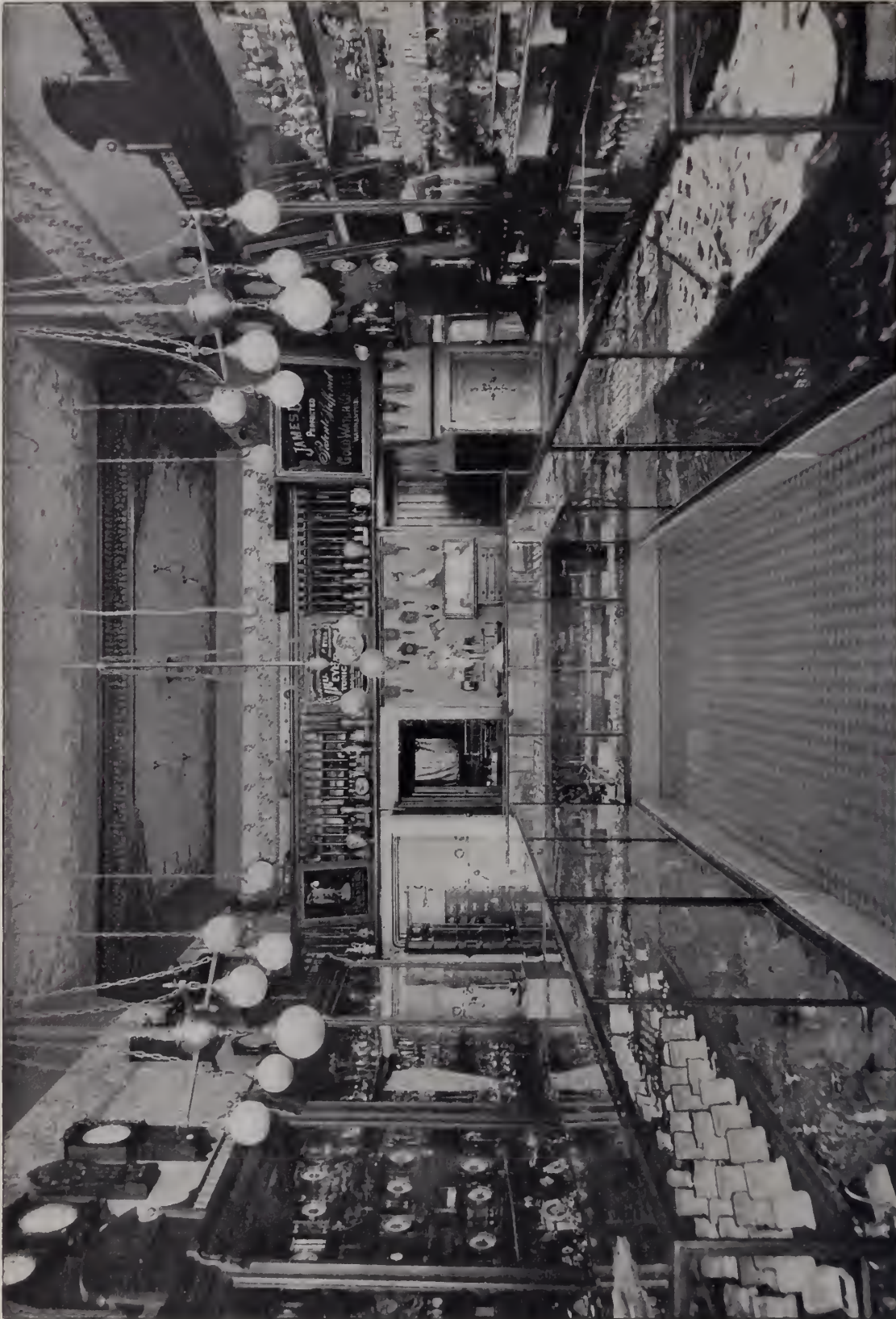

STORE OF THE AMERICAN JEWELRY CO., BAKERSFIELD, CAL. [This firm used our Catalog for three years.]

THE ARNSTINE BROS. COMPANY, Cleveland, Ohio:
 Gentlemen—In regard to results of our Catalogue business as inquired after by you, we beg leave to state the following: Three years ago we used your book, and though we were unexperienced in the needs of that line (Catalogue business), we increased our business materially. Last year just past we used yours doubled our former year's business. Of course we were gaining knowledge of the catalogue business all the time, and this year just past we used a book, as you know, nearly three times the size of our first book, and even in face of the financial condition that the year closed in, we still nearly doubled our last year's business in December.

We have delayed answering your inquiry till now that we might give you the net gains for the year after we had taken stock, but we at this time are so far behind in special order work, that it seems that two months will elapse before we can use our office staff in this respect. So we will simply state the facts without the figures, which we will gladly give you when they are compiled if you write for them.

Business here everybody says is quiet, but we are working nights and feel that our steady hold and gain is attributable only to the liberal use of the book. You'd be surprised to know how far reaching this method of getting business is. Our book has been sent from the Coast to Minnesota, and south to New Orleans, and that the Anticipating a much earlier call from you this year as we have many new friends to incorporate in our new book, which will be separate and distinct from the books of some competitors.

Users of your book feel as one united as we do for it's the only way to kill off unbusiness routine as it does a few **JEWELERS' CIRCULAR COMPANY.**

BAKERSFIELD, Cal., Feb. 6, 1908.
 Three years ago we used your book, and though we were unexperienced in the needs of that line (Catalogue business), we increased our business materially. Last year just past we used yours doubled our former year's business. Of course we were gaining knowledge of the catalogue business all the time, and this year just past we used a book, as you know, nearly three times the size of our first book, and even in face of the financial condition that the year closed in, we still nearly doubled our last year's business in December.

We have delayed answering your inquiry till now that we might give you the net gains for the year after we had taken stock, but we at this time are so far behind in special order work, that it seems that two months will elapse before we can use our office staff in this respect. So we will simply state the facts without the figures, which we will gladly give you when they are compiled if you write for them.

Business here everybody says is quiet, but we are working nights and feel that our steady hold and gain is attributable only to the liberal use of the book. You'd be surprised to know how far reaching this method of getting business is. Our book has been sent from the Coast to Minnesota, and south to New Orleans, and that the Anticipating a much earlier call from you this year as we have many new friends to incorporate in our new book, which will be separate and distinct from the books of some competitors.

Users of your book feel as one united as we do for it's the only way to kill off unbusiness routine as it does a few **JEWELERS' CIRCULAR COMPANY.**

If you are desirous of obtaining the best method of increasing your business, at a nominal expense, write us at once for samples and particulars FREE.

THE ARNSTINE BROS. COMPANY

Makers of Catalogs for Retail Jewelers only

CLEVELAND, - - - OHIO

Los Angeles.

TRADE CONDITIONS.

Most of the retail jewelers in Los Angeles, Cal., report a slight improvement in business conditions. One prominent jeweler reports that his business during the first half of February was almost exactly equal to that of the same period last year. The banks here, which issued a large amount of scrip during the recent financial stringency, have now called in this scrip and are paying out gold currency as usual. This has a tendency to inspire confidence, and there is a general expectation of a gradual improvement in all lines of business.

E. Gerson has begun moving his stock to his new store at 545 S. Spring St.

George Gardner, with the Ernsting Co., San Diego, was here with his bride last week, on a wedding trip.

The H. J. Whitley Co. furnished a number of cups used as trophies at the kennel show held in this city last week.

Col. John Lambert and H. L. Thompson, Joliet, Ill., both stockholders in the Broek & Feagans Co., have, with their families, come to Pasadena to spend the coming Summer.

R. H. Schwarzkopf was in Portland last week, en route home from the east. He reports that while in New York he secured for his firm, Schwarzkopf & Penniman, the agency of J. A. & S. W. Granbery's line.

J. B. Rodgers, Pasadena, was here last week visiting the wholesale houses and purchasing goods for his Spring trade. Among his purchases was included a fine chronometer. He reports trade improving in Pasadena.

A. E. Baraüger, with the E. W. Reynolds Co., returned last week from a successful trip through the northern coast cities. He was absent six weeks. A few days later he started again for another trip over the same route.

L. B. Cohn & Son, proprietors of the Diamond Palace, 123 S. Spring St., will move March 1 to 425 S. Broadway. This is one of the old established firms of this city, the elder Cohn having been in business here since 1869.

The E. W. Reynolds Co. is installing an up-to-date plant for the grinding of bifocal lenses. The instruments used are new automatic machines invented by Walter I. Seymour and constructed here. They have never before been on the market.

The business heretofore conducted under the firm name of Brigden & Pedersen, has been converted into a stock company under the title the Brigden-Pedersen Co. The company is capitalized at \$50,000. The business will be continued at the present location, 507 S. Spring St.

T. W. Copner, until recently superintendent of the manufacturing firm of Jones & Co., has gone into business with Arthur Andrews, manufacturing jewelry, in the Trustee building, No. 1, 342 S. Broadway. The plant occupies the rear portion of the large room in which Gilmore & Lee, wholesalers, are located.

Henry B. Crouch, S. Broadway and Mercantile Pl., surprised his friends and acquaintances last week by quietly slipping out of the city and going to Santa Ana, about 40 miles south of here, where he and Miss Iveline Eicholz, also of this city, were married. The newly-wedded couple have returned to Los Angeles and taken up their

residence at the Hotel Leighton, where the groom formerly resided.

S. Simmons, 315 S. Spring St., reports having just received from his Moqui-Aztec mine, in Nevada, 50 pounds of turquoise taken from a new ledge recently discovered. Some of these stones already polished show a most beautiful matrix laid with gold. The stones themselves have a sky-blue color. Mr. Simmons considers the strike an important one. He expects to start new operations in the mine in April.

Montgomery Bros. exhibited in their windows last week two splendid collections of trophies. One window contained the All-American championship polo trophy of the Coronado Country Club. This is a magnificent piece nearly four feet high, and valued at \$4,000. There were also in the window a number of other cups of the same club amounting to between \$2,000 and \$3,000 in value. In the other window were over 30 cups and trophies of the Southwestern Kennel Club, to be awarded at the dog show held in this city last week.

Carbonate Ore Johnson, so named in consequence of his being the first white child born in the Black Hills mining district, was recently held by United States Commissioner Van Dyke, on a charge of using the mails for fraudulent purposes. Johnson's scheme was to send to prospective customers a bit of stone which he represented to be a hyacinth in the rough. A letter would follow, stating that the recipient could have the stone cut and polished for \$1.50. The government asserts that the stones represented to be hyacinth were cheap specimens of Spanish topaz, costing about 15 cents, wholesale, in Germany. If Johnson is indicted by the Federal grand jury the trial will hinge on expert testimony as to the value of the stones he sold through his mail order scheme. The least penalty for the offense with which he is charged is six months in jail.

F. M. Reiche, 235 S. Spring St., narrowly escaped being the victim of a thief last week. He was called to the telephone by a woman who represented herself to be the daughter of a wealthy woman of this city and one of Mr. Reiche's regular customers. The woman said her husband was going to buy a pair of diamond earrings for her and would probably call on Mr. Reiche soon. Not long afterward he was called to the telephone by a man who represented himself to be the husband of the woman who had previously talked with him about the diamonds. He said he wanted valuable stones and asked what Mr. Reiche had in stock. Mr. Reiche named three pairs of earrings, valued at \$1,000, \$1,200 and \$1,500, respectively. The man said he would take the pair valued at \$1,200; that he would not be able to come to the store for the gems on account of pressure of business, but would send a trustworthy messenger from his office. Not long afterward a young man arrived and said he had been sent for the diamonds. Mr. Reiche, however, insisted on having a written order. The young man went out and returned soon after with an order written on the stationery of the railroad office in which the alleged purchaser is an official. Mr. Reiche, however, was still too cautious to trust the diamonds with the messenger and told him

he would go with him and take them to the purchaser. Mr. Reiche turned to wrap up the diamonds preparatory to taking them with him. When he turned back toward the door the "messenger" had vanished. He soon found out that the alleged buyer knew nothing whatever of any negotiations for diamonds with Mr. Reiche. Mr. Reiche promptly reported the matter to the police and turned over to them the order which the messenger had given him, but no clew has been obtained as to the identity of the would-be thief or thieves.

Omaha.

J. C. Hutson spent a few days of last week in Wahoo, Nebr.

O. J. Hoberg, of Thorpe & Hoberg, Sioux City, Ia., has been chosen vice-president of the Central Whist Association of this city.

The employes of the postoffice purchased from Joseph P. Frenzer last week a handsome solid gold watch and chain, which was presented to retiring Postmaster Palmer.

Earl Clay, engraver for Mawhinney & Ryan Co., and Miss Janet Wallace, with the same firm, were quietly married in this city last week, and left on their wedding trip for South Dakota.

M. J. O'Connell was fined \$25 and costs in police court last Saturday on the charge of stealing a lady's gold watch from the Round Jewelry Co. O'Connell was an employe of the company, and it was asserted that he had pawned watches belonging to the concern.

The C. B. Brown Co. furnished the elaborate diamond cross which was made expressly to order for the Wharton-Kirkendall wedding, last week, as a groom's gift. The cross was of large size, composed of double rows of diamonds, in the center of which was a large diamond.

C. L. Shook, of the Shook Mfg. Co., received a letter during the past week from Denver, Colo., asking for information concerning a man known as "Bloom," who swindled several Omaha jewelers last November, and was traced to Canada, where the goods were restored to the rightful owners. The account of the swindle was published in a previous issue of THE CIRCULAR-WEEKLY. Bloom was not prosecuted and was given his freedom on condition that he surrender all stock. He is now under arrest at Raton, N. Mex., for defrauding several jewelers of Denver, Colo.

Walter Woodall, charged with picking the pockets of J. E. Amos, Du Bois, Wyo., while in this city, last October, of \$1,000 worth of diamonds, has been sentenced to three years in the penitentiary. Mr. Amos passed through Omaha, and while standing in front of a building on Douglas St., was relieved of a box of jewelry consisting of 40 pieces, including many diamond-mounted Masonic emblems. There were six or seven persons implicated in the robbery. Fortunately Mr. Amos recovered all the jewelry, which the police found had been distributed among the several thieves.

The P. H. Boyson Jewelry Co., Cedar Rapids, Ia., is disposing of its stock at a discount sale prior to moving to new quarters in 3d St.



**We Sold
Three Times as
Much as the
Combined Sales
of Two Other
Auctioneers**



Taylor Bros., Houston, Texas. Stock of \$70,000, made two auction sales previous to the one conducted by us. These sales were conducted by auctioneers of national reputation.

We sold, in less time, three times as much as the combined sales of the other two.

We did this in spite of the fact that Houston was suffering from the effects of an enormous bank failure, that two of the largest jewelers in the city were conducting special cut-price sales, that several other large concerns were conducting closing-out sales, and that the city was suffering, to an unusual degree, from the financial depression.

**On Our Way North
WE CAPTURED ANOTHER SOUTHERN TOWN
LENOIR, N. C.**

We made a week's sale for A. W. Dula that amounted to nearly as much as Mr. Dula had sold in the entire year preceding.

Mr. Dula's letter below tells the story and, with that of Taylor Bros., furnishes the evidence to support the above statements.

Messrs. Mitchell & Tillotson.

We have compared the results of your sale with those of two other sales held prior to yours. We find that notwithstanding the other sales were conducted by men of national reputation, and at a time when the country was more prosperous, the sale conducted by you has been more than three times greater than the other two. You have also sold goods that had been in stock many years and that the others could not sell. You have made friends for us during this sale and we have profited in many ways from our association with you during the past fifteen days. Wishing you the success you deserve we remain,

Cordially yours, Taylor Bros.

Mitchell & Tillotson have captured the town and made an auction sale that will be remembered as long as the town stands. Other merchants closed their stores and proprietors and clerks attended our sale and supplied their needs.

Our holiday trade had fallen flat and the auction sale was undertaken as a kind of hopeless last resort. The first day we took in nearly \$1,000 at a profit, and the sale boomed along until we had apparently cleaned up all the loose money in town. The week's business amounted to nearly as much as I had done in the entire year preceding the auction sale.

A. W. Dula.

We can sell at Auction from \$3,000 to \$10,000 per week profitably

MITCHELL & TILLOTSON, Jewelers' Auctioneers

35 Maiden Lane, NEW YORK

Denver.

Nessler & Barker, Colorado Springs, have sold out.

C. E. Barto has offered to make a settlement with his creditors.

Heinly & Bros., Colorado Springs, have been succeeded by W. B. Barnes.

C. B. Lewis, of the Lewis Jewelers' Supply Co., will leave this week on a short trip to Longmont and the northern part of the State.

Mr. Stemens, of J. R. Wood & Sons, has been in this city for a few days, visiting the trade. He reports a very satisfactory business.

Edward Lehman, of the Edward Lehman jewelry Co., returned last week from a short trip. The outlook, he says, is very good for a big Summer business.

J. M. Bolding closed a very successful auction in his store at Longmont, last week. He came down to Denver, Saturday, and is now in town buying a new stock.

Fred Comstock, formerly of Livingston, Mont., has been in this city for a few days. He stopped here to buy tools preparatory to going to Canon City, where he will work for C. C. Patton.

A. Loysen, the Cheyenne detective who windled several jewelers in that town, was tried last week and sentenced to three and one-half years in the penitentiary. The woman who was his confederate was not punished.

The Lewis Jewelers' Supply Co., 1622 Arapahoe St., has caused the arrest at Raton, N. Mex., of M. O. Brittain and Frank Worth, on the charge of using the mails to defraud. Brittain and Worth represented themselves to be connected with some prominent firm and wrote to wholesalers in different parts of the country. When they received a shipment, it is said, they would decamp. The W. W. Hamilton Jewelry Co. has also been after the prisoners for some time. The men were arrested at Raton by Postoffice Inspector Smith and will be tried in New Mexico. They are said to have secured thousands of dollars in the last year, and seldom remained long at one place. The last big haul was secured under the name of Allen & Allen, of Los Angeles. James Lewis will attend the trial as a witness.

Pacific Coast Notes

The Globe Jewelry Co., Globe, Ariz., has moved into newly furnished quarters.

Charles J. Klein, Santa Cruz, Cal., has secured the services of Robert Zurfluth, Los Angeles.

George E. Bangle, Vallejo, Cal., has moved his store three doors east of his present location on Georgia St.

M. F. Noack, Santa Rosa, Cal., has returned from a recent trip to Milwaukee and Chicago, where he purchased stock.

H. A. King, Eureka, Cal., has moved to 17 F St. He will add a watch repairing department to his business in the near future.

The business conducted for three years past by Ira Smith, Pomona, Cal., has been sold to F. E. Lenhart, who will at once take possession.

J. Glick, Stockton, Cal., who has been

confined to his home by illness, is recovering rapidly and will soon be able to attend to his business interests again.

John Reid, a prospector, has discovered a new tourmaline mine near Pala, San Diego county, Cal. He has left a number of samples with the Naylor Gem Co., San Diego.

San Francisco.

W. F. Geerds was laid up with the grippe last week.

Ernest Mueller, Eureka, Cal., visited friends in the trade here, last week.

M. and N. Lichtenstein, Salt Lake City, Utah, visited San Francisco last week.

The store of the Optic Jewelry Co., 242 Kearny St., is being renovated and equipped with new fixtures.

Radke & Co. recently offered a prize cup for the ladies' tennis club. The cup was won by Miss Ida Mearns.

The work on the exterior of Hammersmith & Co.'s new building is about complete, and they expect to move in during the next few weeks.

E. J. Hyde and George H. Doerr, both of Spokane, Wash., spent a few days of last week in this city. They are now in southern California, but will return at the end of the week.

The San Francisco jobbing and manufacturing houses, which have usually made a practice of closing Saturday afternoons between April 1 and Aug. 1, will begin closing at noon on Saturday, this year, after March 1.

Shreve & Co. last Fall announced their intention to reoccupy their building at the corner of Post St. and Grant Ave., next month. The store will be ready for occupancy within a few weeks, but the company is now undecided as to when the movement will take place, and is strongly inclined to remain on Van Ness Ave. until after the next holiday season.

John A. Hammersmith, of Hammersmith & Co., is a member of the present grand jury, which has been investigating abuses in connection with a recent bank failure. The indicted bank officers are now trying to question the validity of the indictment, on the ground that Mr. Hammersmith lives part of the time in Alameda, and is not a legal resident of San Francisco.

Pacific Northwest

R. P. Endicott, of Endicott & Dietz, Myrtle Point, Ore., has sold the bulk of his stock at auction, and in future will conduct a repairing business.

Messrs. Lord and Cochran, members of the firm of the Lord-Cochran Jewelry Co., Goldfield, Nev., have been looking over the situation at Rawhide, Nev., with a view to establishing a branch store there.

The Crescent Jewelry Co., headed by J. S. Zeller, will soon open a store in the building formerly occupied by Paul W. Stecher, Ogden, Utah. Articles of incorporation are being prepared. At present the company will only enter the retail field.

George R. Dodson, Spokane, Wash., left last week for a four months' trip to Europe, visiting England, Germany, France, Spain

and Italy. On his way back he will spend some time in New York making purchases for his Fall and Winter trade.

Milwaukee.

Theodore J. Hoyer, a well-known watchmaker of this city, has taken a position with Samuel Feuerstein, on Washington St., Green Bay, Wis.

Thomas C. Weston was elected trustee of the bankrupt estate of M. M. Huck, the Kenosha (Wis.) jeweler, at the first meeting of creditors in the office of E. Q. Nye, referee in bankruptcy, this city.

F. A. Averbeck, 29 S. Pinckney St., Madison, Wis., was among the donors of prizes in the competition at the annual convention of the Wisconsin Buttermakers' Association, which met in Milwaukee. The Averbeck prize, a gold watch charm, was won by L. P. Holgerson, Troy Center, Wis.

H. P. Alsted, of the Alsted-Kasten Co., one of Milwaukee's largest jewelry firms, is now a full-fledged citizen of the United States. In 1844, when Mr. Alsted came to Milwaukee from Denmark, he took out his "first papers." He has put off the "second papers" year by year, but finally took them out. Mr. Alsted is one of the oldest and best known jewelers in the west.

William Lawlor, Ripon, Fond du Lac County, who was adjudged a bankrupt Oct. 3, last, has petitioned the United States Court for a full discharge of all his debts in bankruptcy, and a hearing on this petition will be held in this city, March 4, before Judge Joseph V. Quarles, at 10 A. M., at which time the creditors may appear and show cause, if they have any, why the discharge should not be granted.

A number of the large Milwaukee jewelry stores that operate optical departments are taking part in the movement for the formation of the Badger State Optical Association. The jewelry men see in this movement a benefit, for the object of the association will be to secure an optical law for Wisconsin. Practically every State surrounding Wisconsin has such a law, and the scores of itinerant opticians, so-called, who are driven from these States by the law come to this State. The result is, it is claimed, that men utterly incompetent and wholly unfitted to handle optical goods establish themselves in business and degrade the trade by underselling legitimate dealers. The new association will attempt to secure a statute that will prevent this promiscuous handling of optical goods and that will at the same time be less severe than a full medical examination. A meeting was held this week in Milwaukee and a temporary organization was effected. E. J. Jensen was elected chairman; William Kah, Jr., vice-chairman; Franklin Thomson, secretary Milwaukee Jewelers' Club and Wisconsin Retail Jewelers' Association, secretary; Louis Muskat, treasurer. A permanent association will be formed in Milwaukee on July 9 and 10, at which time opticians from all over the State will gather at the Blatz Hotel, in response to invitations from the temporary directorate.

Conrad Richenbach, Walkerton, Ont., has given a renewal bill of sale for \$800 to J. Wingfelder.

Kansas City.

The stock of Gurney & Ware is being closed out at auction. The fixtures were sold at auction Monday, Feb. 24.

Charles Moll, formerly in the watchmaking department of Clem. B. Altman, of this city, has accepted a situation with A. Y. Boswell, Tulsa, Okla.

Arthur Foster, Kansas City, and W. McCluskey, Nelson, Nebr., are enrolled as students at the Kansas City Polytechnic Institute.

W. C. Vandell and J. H. Whitney, representatives of the Edwards & Sloane Jewelry Co., are both on the road again. The business of their first trips of the year was fully up to the business of a year ago.

The tenants of the Missouri building, which was damaged by fire last November, are much pleased over the completion of the repairs. Kionka & Kionka and the Kansas City Polytechnic Institute find their quarters much improved.

F. B. Hurd, Breckenridge, Mo., who recently auctioned off his stock, was in this city last week. He announced his intention of going west for six or eight months to recuperate. Six or seven years of close application to business has impaired his health, rendering rest and recreation necessary.

W. E. Emerson, Pleasant Hill, Mo., has entered as a full course student at the Kansas City Horological and Optical School. W. W. Spaulding and wife, who have finished a course in optics, are looking for a location to go into business. They will probably select some town in Kansas.

The following out-of-town jewelers were in this city during the week: W. W. Whiteside, Liberty, Mo.; W. F. Kirkpatrick, St. Joseph, Mo.; W. H. Meyer, Lawson, Mo.; W. H. Hoover, St. George, Kans.; E. Parker, Gilman City, Mo.; C. E. Dale, Bennington, Kans.; George W. Lewis, Herington, Kans.; Geo. C. Wetzell, Linwood, Kans.; Jno. H. Gingrich, Moberly, Mo.; D. E. DeLanty, Parkville, Mo.; W. S. Noble, Drexel, Mo.

Detroit.

W. A. Sturgeon is in New York on a two weeks' trip.

R. Friday, New Baltimore, was a recent visitor in the city.

George A. Allsopp, Jr., of Allsopp & Allsopp, visited the trade here recently.

J. E. Goldberg, Goldberg Bros., was in New York recently, purchasing jewelry.

L. H. Cooper, Oxford, came in for the recent auto show, and called upon the trade while here.

Henry Raymond, of Worthington & Raymond, tool manufacturers, New York, was in town last week.

L. H. Schaefer, Chicago, was at the Pontchartrain Hotel last week, as was also his representative, Edward Strang.

The Healy Jewelry Co., doing business in the Buhl Block, has discontinued business, paying off all indebtedness in full.

Richard M. Johnson, with R. J. F. Roehm & Co., was called to Dayton last week on account of the death of his father.

Emil Rosenau, of the firm of Rosenau Freres, Frankfort-on-the-Main, Germany, manufacturers of Dutch silver, was in town

last week. His American trip this season will extend no further west than Denver.

Wm. Seisco was caught, about a week ago, attempting to break into the retail jewelry store of M. L. Rovin, 433 Hastings St., this city, and was taken into custody by patrolmen Rickard and Stoddard. Half a dozen skeleton keys were found in the possession of the prisoner.

E. C. Avery, traveling for the Chas. A. Berkey Co., had a strenuous time recently in the northern part of the State, on account of the heavy snowfall. He was snowed in on one train all night, and on another train had the experience of progressing but 30 miles in a day, battling with the snow. Travelers generally have had great difficulty in making the smaller towns on account of the branch railroad lines being blocked.

St. Louis.

E. A. Schoenle, of the Maschmeyer-Richards Silver Co., has departed on his regular Spring trip to the Pacific Coast.

Edwin Massa, vice-president of the Bauman-Massa Jewelry Co., returned last week from a business trip through Oklahoma and the southwest.

Max Bauman, of the Bauman-Massa Jewelry Co., is recuperating at San Antonio, Tex., and is said to be contemplating returning to St. Louis early in the Spring.

H. W. Thompson, Muskogee, Okla., has removed to larger and more commodious quarters, and his new store is said to be one of the handsomest and most complete in the new State.

George Porth, Jefferson City, Mo., was in St. Louis last week on his return from Mascoutah, Ill., whither he went to attend a family reunion which celebrated his mother's 70th birthday.

W. H. Wheeler, Palmyra, passed through this city last week on his way to Hot Springs, Ark., where he will spend some time in an effort to regain his health. Mr. Wheeler has been in poor health for some time.

The Brooks Jewelry & Optical Co., of this city, recently elected the following officers and directors. President, James J. Burke; vice-president and treasurer, Paule Pautier. The officers and Mrs. A. M. Burke constitute the Board of Directors.

Among the out-of-town jewelers who called on the trade last week were the following: E. J. Baumann, Ste. Genevieve, Mo.; Mr. Armstrong, of the Armstrong Jewelry Co., Brownwood, Tex.; C. F. Gash, Fredericktown, Mo.; and General Hudson, of Shibley & Hudson, Wooster, O.

A. C. Arnold, of Arnold & Co., Texarkana, Ark., is selling out his stock and will retire permanently from the jewelry business to go into the lumber business. Mr. Arnold will establish a lumber mill in the great southern timber regions, his father-in-law being one of the largest lumbermen in the south.

Hosmer Farrington Jackson, an optician of East St. Louis, Ill., was stricken with apoplexy last week, as he was about to retire for the night and died shortly after. Mr. Jackson called to his wife and 10-year old child as he felt his illness approaching and they summoned physicians. He was 50 years old.

Sam Kober, secretary of the E. M. Jewelry Mfg. Co., returned last week a successful trip of three weeks through Texas, Oklahoma, Arkansas and southern Missouri. Mr. Kober reports that trade fairly active in the southwest.

The Mermod, Jaccard & King Jewelry Co. will open a branch store in the F. building, at 4th St., between Pine Chestnut Sts., to be known as "Ye Shop." The new store will be well stocked with jewelry and will have an optical watch repairing department. The building, although it is strictly an skyscraper in the downtown district, is situated for a high-grade jewelry store as it is in the center of the financial district, opposite the Planters' Hotel and joining the Merchants' Exchange.

Herman Mauch was the toastmaster of the ninth annual banquet of the F. School Patrons' Alliance last week at Hotel Jefferson. Mr. Mauch is the president of the organization, which has grown to large proportions and much success under his regime. The Alliance presented to him a library chair in appreciation of his two years' work as head of the organization. The speech of presentation was made by P. H. Felker, who paid a graceful tribute to Mr. Mauch's public services.

Indianapolis.

Horace A. Comstock has returned from Cincinnati, where he attended the meeting of the National Bowling League.

Burton E. Chapman, of the Elgin National Watch Co., attended the convention of the Indiana Retail Jewelers' Association last week.

Thomas N. Sykes, Shelbyville, was defrauded last Thursday by a man who gave his name as Newton D. Parker, Cincinnati. Parker was arrested while at the ready to leave town. He presented a check for \$25 at the store in payment of \$12 watch and received \$13 in cash.

David S. Gribben, of Gray, Gribben & Gray, has put his mathematical ideas many years into a little book entitled "Mathematics Made Easy." The book, 126 pages, shows a number of new methods of solving the knotty problems. Later he expects to issue another book along similar lines.

Suit was brought last Wednesday against Leopold Krauss, of Krauss & Sons, against the Indiana Board of Registration and Examination in Optometry. He is to compel the board to issue a license to him stating that despite the fact that he has been a practicing optician for about 20 years, he has been denied a license.

At the exhibit in connection with the convention of the Indiana Retail Hardware Dealers' Association last week, the Optician Community had an attractive showing of silverware and hardware specialties. Exhibit was in charge of Alfred C. St. Louis, western representative of the company, and Frank Prime, of the fact Dealers were shown the statement of a five-year advertising contract with THE JEWELERS' CIRCULAR—WEEKLY as an example of the wide publicity that will be given the company's product.

INDEX TO ADVERTISEMENTS.

John Mfg. Co.	Inside front cover	Hedges, A. J., & Co.	23	Price, Cyrus, & Co.	42
American Gem & Pearl Co.	57	Hedges, Wm. S., & Co.	54	Prior, Charles M.	26
American Platinum Works	106	Heller, L., & Son	44	Providence Stock Co.	28
American Watch Case Co.	59	Herpers Bros.	98	Prybil, P.	98
Anderson, P. E., & Co.	98	Himalaya Mining Co.	56	Racine, Jules, & Co.	92
Arizona Turquoise Mines Co.	46	Hodenspyl & Walker	50	Randall, C. Ray	66
Arnstein Bros. & Co.	38	Hoffman Novelty Co.	30	Ranlett & Lowell Co.	92
Arnstein Bros. Co.	72	Hold On Clutch Co.	27	Reichhelm, E. P., & Co.	98
Arnonson & Spiegel	29	Hotel St. James	100	Reichman, A.	57
Arnstein, John, & Son	106	Howard, E., Watch Co.	69a, 69b	Renzelehansen, W. F., & Co.	107
Attag, Perine & Co.	52	Huba, Louis W.	100	Revell, A. H., & Co.	105
Aker, Geo. M.	107	Hyde & Co.	92	Rice's, Bernard, Sons	102
Ahl, Webb C., Watch Co.	93	Illinois Watch Co.	70	Richards, J. M.	68
Aschikopf, Henry C.	25	Irons, Joseph	100	Richardson, Enos, & Co.	18
Assett Jewelry Co.	28	Irving Cut Glass Co.	100	Robbins, Chas. M., Co.	25
Astes & Bacon	14	Jacot Music Box Co.	100	Robert, E. E.	91
Aerge, J. & H.	106	Janitschek Co.	104	Rockford Watch Co.	92
Aulings, Chester, & Son	50	Jeanne, F. A.	46	Roger Williams Silver Co.	26
Aippart, Griscom & Osborn	23	Juergensen, Jules	94	Rohrbeck, John E.	25
Aishop, R. W.	105	Juzek, T. J., & Co.	106	Roseman, A.	44
Aackinton, R., & Co.	11	Kahn, L. & M., & Co.	38	Roy Watch Case Co.	82
Aorgzinner, S., Co.	105	Keck, Herman, Mfg. Co.	40	Rudolph & Snedeker	94
Aorrelli & Vitelli	57	Keller Jewelry Mfg. Co.	22	Rumpp, C. F., & Sons	104
Aowden, J. B., & Co.	31	Kelly & Stehman	100	Saunders, Meurer & Co.	54
Aadley Polytechnic Institute	92	Keut & Woodland	22	Schickerling Mfg. Co.	58
Ariggs, D. E., Co.	14	Ketcham & McDougall	30	Schnitz & Co., Inc.	56
Aryant, M. B., & Co.	31	Keystone Watch Case Co.	88	Sessions Clock Co.	93
Aarter, Howe & Co.	21	Kirby, H. A.	62	Shepard Mfg. Co.	59
Aatham National Bank	66	Kohlbusch, Herman, Sr.	106	Smith, Alfred H., & Co.	44
Ahicago Art Metal Works	24	Kohn, Alois, & Co.	25	Smith, Frank W., Co.	16
Ahopard Frères	24	Kremenz & Co.	17	Snow & Westcott	24
Aohen, J. J.	44	Langendorf Watch Co.	92	Sohn & Hyman	69c
Aottle, S., Co.	21	Larter & Sons	36	Solidarity Watch Case Co.	15
Arees & Court	30	Lederer, S. & B., Co.	26	Spencer, E. L., Co.	27
Arohn, M.	32	Lees & Sanders	107	Star Watch Case Co.	6
Aross & Beguelin	62	Lelong, L. & Bro.	106	State Bank	64
Arossman Co.	44	Lewy & Cohen	22	Steiner, Louis	102
Arouch & Fitzgerald	105	Lisner, D., & Co.	15	Stern Bros. & Co.	46, inside back cover
Aray, Clark & Co.	23	Lissauer & Co.	46	Sternau, S., & Co.	12
Aeacon, Louis J.	21	Lorsch, Albert, & Co.	38	St. Louis Watchmaking School	68
Aetroit Show Case Co.	105	Loth, Joseph, & Co.	32	Street, Geo. O., & Sons	21
Aixon, Wm., Inc.	68	Lowe, Edwin, & Co., Inc.	28	Sussfeld, Lorsch & Co.	102
Aoran, Bagnall & Co.	28	Maintien Bros. & Elliot	32	Swartchild & Co.	59
Aorfinger, C., & Sons	100	Market & Fulton National Bank	64	Theberath & Co.	68
Araper, O. M., Estate	29	Mathey Bros., Mathez Co.	30	Tiffany Electric Mfg. Co.	95
Aarbois Watch Case Co.	93	Mercantile National Bank	65	Title Guarantee & Trust Co.	64
Aueber-Hampden Watch Mfg. Co.	10	Meyerowitz Bros.	40	Trout, Charles L., & Co.	21
Aunn, T. J., Co.	26	Miller, Fuller & Whiting Co.	29	Unique Art Glass & Metal Co.	102
Aurand & Co.	18	Miller, L. A. (Insurance)	22	Untermeyer-Robbins Co.	58
Aichberg & Co.	56	Mitchell & Tilotson	74	Urich, S.	69c
Aisenmann Bros.	50	Morstrom, W. G.	69c	U. S. Smelting & Refining Works	107
Elgin National Watch Co.	86	Mount & Woodhull	52	Vacheron & Constantin	91
A. P. H. Chain Catch	30	Myers, S. F., Co.	24	Van Dam, Eduard	40
Aahys, Joseph, & Co.	3	Nassau Bank	64	Van Dusen & Stokes Co.	68
Aeldenheimer, Louis	69c	New England Watch Co.	94	Wachter Mfg. Co.	94
Aoster, Theodore W., & Bro. Co.	34	New York Jewelry Purchasing Co.	105	Wadsworth Watch Case Co.	9
Areeman, B. S., Co.	28	Nissen, Ludwig, & Co.	52	Waite-Thresher Co.	32
Afreund, Henry, & Bro.	16	Noel, Rudolph, & Co.	68	Waltham Watch Co.	84
Aalaway, J. H. & F. H.	98	Omega Watches	91	Washburn, C. Irving	30
Aarreaud & Griser	25	Oneida Community, Ltd.	Outside back cover	Wells, Chester H.	28
Aates, A. E.	69c	Oppenheimer Bros. & Veith	40	Wendell & Co.	7
Aillette Sales Co.	33	Oskamp-Nolting & Co.	24	Wheeler, Hayden W., & Co.	46
Aoodfriend Bros.	54	Osmers-Dougherty Co.	22	Whiting & Davis	12
Aorham Co.	60	Osmun-Parker Mfg. Co.	18	Whiting Mfg. Co.	13
Agrabemann, Herman	92	Ostby & Barton Co.	31	Wightman & Hough Co.	24
Areene, Wm. C., Co.	26	Pairpoint Corporation	100	Wittnauer, A., Co.	92
Ariffoul, August	107	Papazien, A. D.	94	Wodiska, Julius	25
Augenheim, M.	29	Patek, Philippe & Co.	90	Wolcott Mfg. Co.	8
Aagstoz, T. B., Ltd.	107	Penfold, Wm. C., Co.	95	Wollstein, L. & M.	107
Aammel, Riglander & Co.	108	Piteairn, W. S.	104	Wood, Chas. F., & Co.	50
Aarris & Harrington	93	Pitzele, S.	56	Wood, J. R., & Sons	4, 5
Aaskell, Henry C.	69c	Potter & Buffinton Co.	27	Zarenbowitz, A.	98
		Pratt, J. W., Printing Co.	19, 20	Zimmer, Henry, & Co.	106

Special Notices.

Situations Wanted.

FIRST CLASS watchmaker wishes position; best references. Address "H. G. C., 3458," care Jewelers' Circular-Weekly.

WATCHMAKER and optician wishes position; can furnish best references. Address "L., 3370," care Jewelers' Circular-Weekly.

WATCH and CLOCKMAKER wishes position; can furnish best reference; salary, \$12 per week. John Hofmeier, 41 W. 128th St., New York.

WATCHMAKER and engraver; experienced on all grades of watches; address stating all particulars. "Watchmaker," 103 Broadway, Princeton, Ind.

ENAMELER, thoroughly experienced on emblems, class pins, jewelry, etc., open for a position. "Hustler, 3466," care Jewelers' Circular-Weekly.

YOUNG MAN, 20, desires position as clerk or salesman in wholesale or retail jewelry house. Address S. Herzberg, 235 E. 11th St., New York.

ENGRAVER wants position; would also act as salesman; will send samples of work and good reference. Amer Myers, 624 S. Queen St., Lancaster, Pa.

POSITION by first class watchmaker and engraver; young man; steady and sober; will not go south. Address "Ed.," 817 W. Main St., Enid, Okla.

WATCHMAKER, engraver and salesman, young man, good appearance, A1 references; east preferred. Address "Grant," 11 Smith Block, Auburn, N. Y.

YOUNG MAN wishes position as salesman, order or stock clerk in wholesale, retail jewelry or silver house. Address "X., 3072," care Jewelers' Circular-Weekly.

PLATER, colorer and etcher, experienced on jewelry, silver and metal novelties, desires steady position. Address "H., 3208," care Jewelers' Circular-Weekly.

STRICTLY first class watchmaker, with first class tools and references, wishes position; New York City preferred. "H. R., 3382," care Jewelers' Circular-Weekly.

WANTED, by strictly first class watchmaker, position in west or middle west; best of references; 11 years at bench. Address "X.," P. O. Box 524, Sacramento, Cal.

FIRST CLASS designer and engraver desires position with reliable house, at once; long experience; references. Address "E., 3494," care Jewelers' Circular-Weekly.

SWISS WATCHMAKER, 20 years' experience on all kinds of watches; references and samples; fix four to five watches a day. "Watchmaker," 231 W. 22d St., New York.

ENGRAVER, first class, monograms, inscriptions, script, old English, crests, coats-of-arms, carving, cutting for enamel; excellent references. "R. C.," 1123 Bannock, Denver, Colo.

FIRST CLASS watchmaker, with tools, desires position at once; middle age man; competent to handle railroad work. Address "E. H. B.," 45 Charles St., Springfield, Mass.

A YOUNG married man, age 28, wants position as pawn clerk or salesman; 15 years' experience; good reference and address. Address "B., 3464," care Jewelers' Circular-Weekly.

WATCHMAKER, 28 years at the bench, desires position; experienced in all kinds of watch and clock repairing; salary, \$25 per week. John Brown, 4 Union Sq., New York.

EXPERT WATCHMAKER, optician and clock repairer, 22 years' experience; all tools and trial case; \$20 a week; honest and sober; good references. Charles Beavis, Pineville, Ky.

WATCHMAKER, four years' experience, can do optical work and some jewelry repairing; own tools; A1 references. Address "Watchmaker," 932 S. 3d St., W., Cedar Rapids, Ia.

EXPERIENCED WATCHMAKER and engraver would like steady position in first class store; desires a change; east preferred. Address "C., 3268," care Jewelers' Circular-Weekly.

A1 MANUFACTURING JEWELER, expert on platinum, order work and repairing, also stone setter, wishes position; best reference. Address "P. F., 3361," care Jewelers' Circular-Weekly.

ENGRAVER and clock repairer desirous of locating in the middle west, Kansas or Oklahoma preferred; good references and samples furnished. Jas. E. Spitzmesser, Independence, Kans.

ENGRAVER and salesman, first class, monogram, inscriptions, etc., on silverware and jewelry; 16 years' experience; New York City reference. "M., 3477," care Jewelers' Circular-Weekly.

YOUNG LADY desires position with jewelry house; have experience with stock and general office work, also stenographer and typewriter. "K., 3279," care Jewelers' Circular-Weekly.

GOOD ENGRAVER and salesman wishes to make a change; can also repair clocks; references and sample of engraving furnished; age 24, single. "A., 3474," care Jewelers' Circular-Weekly.

YOUNG MAN, 21, having almost five years' experience with diamond importing house, desires to make a change; can furnish best of references. "R., 2906," care Jewelers' Circular-Weekly.

JEWELER, 12 years' experience in repairing, new work, also a diamond setter, wishes position; willing to go out of town. Address F. Sandler, care L. Kopelman, 127 Pitt St., New York.

SALESMAN, well acquainted in New York, Pennsylvania and New England, desires change; seven years with present firm; best reference. Address "B., 3430," care Jewelers' Circular-Weekly.

WATCHMAKER, with optical diploma, open for engagement at high class work; trained in London; 20 years' American experience; highest references. "H. G., 3352," care Jewelers' Circular-Weekly.

WATCHMAKER, young man, experienced in all grades of watches, with complete tools, desires position with a chance to learn engraving preferred. Address "B., 3450," care Jewelers' Circular-Weekly.

SITUATION WANTED by first class watchmaker, clock and jewelry repairer; 12 years' experience in store and factory; first class salesman and window trimmer. Address "H.," 235 Robbins St., Waltham, Mass.

BY TRAVELING salesman, with 10 years' acquaintance with the best jewelry trade in New York, Pennsylvania, Ohio and Kentucky; best references. Address "M. Y. G., 3420," care Jewelers' Circular-Weekly.

FIRST CLASS watchmaker, with tools, desires position in a first class jewelry store; middle aged man; competent to handle railroad work; south or east preferred. Address "E. L. E.," 323 W. 7th St., Canton, O.

YOUNG MAN, 20, desires position as clockmaker and assistant watchmaker; almost three years' experience under A1 Swiss mechanic; best references; all tools. Address "Watchmaker," 1140 N. 9th St., Reading, Pa.

SITUATION WANTED by a high class watchmaker, jeweler and engraver, who has had 25 years' experience in large cities; complete set of tools and reference. Address "H., 3455," care Jewelers' Circular-Weekly.

JOURNEYMAN JEWELER would like permanent position in west, manufacturing or repair shop; fair knowledge of tools, dies, design, etc.; a first class all around man. Address "R., 3492," care Jewelers' Circular-Weekly.

YOUNG MAN, 21, having five years' experience in the jobbing line as salesman and charge of stock, desires position with manufacturer or jobber; highest references. "Reliable, 3456," care Jewelers' Circular-Weekly.

SALESMAN, calling on New York City and out-of-town trade, desires change with A1 jobbing or manufacturing house; seven years' experience; highest references. Address "R., 3021," care Jewelers' Circular-Weekly.

WANTED, manufacturer's line of filled jewelry, silver or plated toilet or flat ware on commission; established trade in New York, Philadelphia, Baltimore and middle west. Erle R. Sheppard, 53 Maiden Lane, New York.

A FIRST CLASS WATCHMAKER, with many years' experience in high grade adjusting and complicated watch work, wishes to make a change in his position. Reply to Nils Zetterquist, 70 Columbus Ave., Waltham, Mass.

POSITION WANTED by an energetic young man, a practical watchmaker, jeweler and salesman, has also some knowledge of optics, with a reliable firm in New York or Brooklyn. "N., 3457," care Jewelers' Circular-Weekly.

WANTED, position as salesman or manager with retail jeweler; 15 years' experience; good references; married, 28, good address; I can fill the bill; just the man you want. J. P. Turner, 1729 Edmondson Ave., Baltimore, Md.

FOREMAN; six years' experience in jewelry factory, a perfect knowledge of running one, a stone setter by trade; can furnish best of references as to ability and honesty. Address "D., 3487," care Jewelers' Circular-Weekly.

DIAMOND SETTER and jewelry repairer, having a general knowledge of jewelry, 10 years' experience, best reference, can do some watch repairing and engraving, desires position. Address "C., 3472," care Jewelers' Circular-Weekly.

WANTED, position by a first class toolmaker, thoroughly experienced on class pins, medals, monograms and jewelry of every description; wishes to connect with a good concern. Address "Reliable, 3462," care Jewelers' Circular-Weekly.

YOUNG MAN, 26, single, practical watchmaker, seven years in large factory on high grade work, wants position as missionary or outside salesman New England or New York preferred. Address "W., 3461," care Jewelers' Circular-Weekly.

EXPERIENCED jeweler and diamond setter desires a position as salesman with first class house; can give estimates and take charge of repair department; best references. Edward Frecking, 326 N. State Ave., Indianapolis, Ind.

A GOOD, experienced manufacturing jeweler, who understands fine and cheap work, has all modern designs necessary to be used, is looking for a position as a foreman and to take charge of factory. Address "T., 3408," care Jewelers' Circular-Weekly.

A1 WATCHMAKER, experienced on railroad work, desires position at once; at present head watchmaker for New York Central inspector also experienced factory finisher of high grade watches. Address "L. R., 3449," care Jewelers' Circular-Weekly.

BY A FIRST CLASS manufacturing jeweler and diamond setter, also an A1 repairer and all around man; young, sober and reliable, with good recommendation; northwestern States; retail stores only need apply. Address Robert W. C. Pfaeffle, Enid, Okla.

YOUNG WOMAN, stenographer, typewriter, has knowledge of bookkeeping, accurate and reliable, can adapt herself to any business, wishes permanent position at a moderate salary; Maiden Lane references. Address "Remington, 3357," care Jewelers' Circular-Weekly.

YOUNG MAN, 12 years in the business, with New York City experience, married, desires position as salesman with retail store; New York City preferred; understands taking in repair work of all kinds. Address "L., 3425," care Jewelers' Circular-Weekly.

FIRST CLASS watchmaker, 30 years' experience, wants position; thoroughly competent on complicated work, railroad watches and adjusting, can take care of repairing department; New York or nearest vicinity preferred. Address "S., 3380," care Jewelers' Circular-Weekly.

LIVE MAN, 26, having 10 years' practical experience in all branches of silverware manufacture, desires position in factory, stock room or wherever both definite and general knowledge is required; high class man; excellent references. "Capable," 639 Lafayette Ave., Baltimore, Md.

FIRST CLASS watchmaker, age 30, 16 years' experience on American, Swiss and complicated watches, wants permanent position; no time-killer, but fast and reliable worker; A1 references; state salary; west or south preferred. Address "F. Z., 3429," care Jewelers' Circular-Weekly.

SALESMAN, with an established trade of 25 years, would like a position to travel, selling watches, diamonds and jewelry in the States of New Jersey, Pennsylvania, New York, Connecticut and Massachusetts; best of reference given. Address "A. B. C., 3435," care Jewelers' Circular-Weekly.

WATCHMAKER wishes permanent position; 16 years' experience; American, 33 years of age, competent to take full charge of repair department and estimate on work; familiar with railroad work and inspection service; would not go west of Ohio; only good houses need apply. Address "W., 3499," care Jewelers' Circular-Weekly.

FIRST CLASS watchmaker, fine letter and monogram engraver and graduate optician; 23 years' experience, five years' on railroad watches; several years in present position; do not repair clocks or jewelry; Indiana or Illinois preferred; would not go east of Indiana; town 8,000 to 25,000; first class references. Address "S. J., 3383," care Jewelers' Circular-Weekly.

GENTLEMAN, with 20 years' experience in the various branches of the jewelry business, A1 watchmaker and jeweler, desires position as head of watch repair or high grade clock department, salesman or to take entire charge of store, where energy, ability and honesty are appreciated; refined, of good address and have gilt edge references. Address E. Cochrans, 616 S. St. Clair St., Toledo, O.

Side Lines Wanted.

WANTED, up-to-date manufacturer's line 14K jewelry to be sold on commission in territory west of Salt Lake City; established trade with leading jewelers; headquarters at San Francisco; best of references. Address, "P., 3469," care Jewelers' Circular-Weekly.

Help Wanted.

WANTED, an engraver, who could assist in clock and jewelry work. S. Joseph & Sons, Des Moines, Ia.

WATCHMAKER, engraver and salesman; steady position; send reference; state age, experience and salary wanted. P. O. Box 453, Wheeling, W. Va.

WANTED, young man, about 18, who has had some experience in clock repairing and who is willing to make himself useful around the store. Apply 641 Eighth Ave., New York.

YOUNG MATERIAL man to take advantage of a fine opportunity, wait on trade and fill mail orders accurately; give full particulars. Henry Cowan, Jewelers Building, Boston, Mass.

WALSMAN, acquainted with Newark manufacturing trade, wanted to sell precious stones; answer stating references and salary expected. "Importer, 3490," care Jewelers' Circular-Weekly.

FIRST CLASS watchmaker and engraver, and preferably one who can also do jewelry work; permanent position and good wages; references required. Address "F., 3496," care Jewelers' Circular-Weekly.

WATCHMAKER, jeweler and plain engraver; must have 10 years' experience; married man preferred; permanent position; send references and state salary in first letter. Address "H., 3411," care Jewelers' Circular-Weekly.

WANTED, watchmaker and general man to take charge of small branch store; good references required; young man with some knowledge of French clocks and tools preferred; chance for advancement. Box 118, Stockbridge, Mass.

WANTED, a competent jeweler, who can do all kinds of repairing, new plain work and do diamond setting; single man preferred, who also has had experience in waiting on customers; write fully, stating age, experience and previous employers in first letter. Edward Vail & Co., Wichita, Kans.

LEADING and successful manufacturing concern, making britanna novelties, is now developing a general hollow ware line and will need service of competent salesman who is thoroughly familiar with demands of trade; all applications treated in confidence. Apply Box 3426, care Jewelers' Circular-Weekly.

FACTORY SUPERINTENDENT; must have thorough knowledge of manufacture of Sheffield silver; familiar with and able to figure factory costs and install economic methods; full details of experience, with whom, age and salary expected, must be given or application will not be considered. Address "Sheffield, 3443," care Jewelers' Circular-Weekly.

ABRAHAM & STRAUS, Fulton St., Brooklyn, jewelry department, require a man with a general knowledge of watches and jewelry as assistant buyer; must possess executive ability and have department store experience. Apply by mail only.

WATCHMAKER and jewelry repairer who can translate from French and German into English, and who knows something about the theory of horology, will be offered desirable position; state age, nationality, education, general qualifications, etc. "R. J., 2314," care Jewelers' Circular-Weekly.

Business Opportunities.

FOR SALE, the patent right to manufacture a roller jewel setter that will set a roller jewel in 30 seconds, or will sell the patent outright. S. W. Christine, Bangor, Pa.

STOCK and fixtures located in western State; annual sales \$12,500; \$5,000 will buy; good run of bench work; good prices. Address "C., 3440," care Jewelers' Circular-Weekly.

A RING FACTORY, doing fine work, and well equipped; a close price will be considered for cash offer; write if interested. Address "N., 3290," care Jewelers' Circular-Weekly.

WILL PURCHASE, for spot cash, jewelry, silverware, clocks, etc., also jewelry and silverware lined boxes new or second hand. Sterling Jewelry Co., 54 W. 34th St., New York.

FULLY EQUIPPED gold jewelry factory in Newark, N. J., for sale, manufacturing rings, brooches, scarf-pins, etc., or will take a partner. Answer "C., 3445," care Jewelers' Circular-Weekly.

FOR SALE, the old established two window jewelry store on one of New York's busiest avenues, with or without stock, at reasonable price; must be sold at once. M. Hodges, 2168 Third Ave., New York.

PATENT NO. 835,912, an attractive novelty, can be manufactured in gold, silver or plate; patent and tools for making are for sale; cash offers only. Address "Sacrifice, 3437," care Jewelers' Circular-Weekly.

FOR SALE, complete electro-plating plant; solutions and equipment for all kinds of work; a bargain to the right party; must be sold to close an estate. Address Warner Silver Co., 42 Beach St., Bridgeport, Conn.

JEWELRY STORE for sale, the best location in Paterson, N. J.; profits average \$150 a week; real estate business in southern California compels me to sell. Chas. H. Kelley & Co., 123 Main St., Paterson, N. J.

FOR SALE, on account of sickness, an enameling shop for jewelry, established for 25 years; would also accept a competent man for partner instead; location, Newark, N. J. Address "E., 3448," care Jewelers' Circular-Weekly.

MANUFACTURING jewelry business in Maiden Lane district, up-to-date shop, electric lathes; cheap rent; local repair and mounting trade; plant and good will \$1,200 cash. Address "Cash, 3438," care Jewelers' Circular-Weekly.

GOOD TOWN of 2,000, no other watchmaker within 20 miles, all the work one man will need; I will sell or exchange my fixtures worth \$200 for jewelry, also I will sell or exchange two houses and lots worth \$500. Address John L. Ward, Munday, Texas.

JEWELRY FACTORY for sale or to let; safe, tools, models, flasks and all machinery in good order, running by electricity or steam power; good light and ventilation; low rent; Fulton St., near Nassau St., New York. Address "Z., 3399," care Jewelers' Circular-Weekly.

FOR SALE, jewelry store in busy Pennsylvania town, about 16 miles east of Pittsburgh; stock will invoice about \$8,000, mainly watches, movements and diamonds; good watch repairing trade; cheap rent; reason for selling, owner died. Address "W., 3432," care Jewelers' Circular-Weekly.

JEWELRY STORE, no competition; county seat; population, 2,500; best location in northern Wisconsin; hunting and fishing the very best; \$2,500 necessary to handle proposition; will lease or sell business property; reference furnished to parties who mean business. Randall Jewelry Co., Phillips, Wis.

FOR SALE, a complete jewelry store set of fixtures, all in excellent condition; low price to quick buyer; good opening for a good watchmaker and optician; best location in city; population, 4,000, and only one jeweler and no optician; write for particulars. Address Lock Box 386, North Baltimore, Ohio.

DO YOU WISH TO RETIRE? Why not turn your entire store or surplus stock into cash? We pay the highest prices, also advance liberal cash amounts on stocks; communicate with us before consulting others; we act quick and strictly confidential. Brooklyn Purchasing Syndicate, 608 Broadway, Brooklyn, N. Y., Telephone, 2328 Williamsburg.

\$7,000 WILL BUY best jewelry and optical business in good manufacturing town of 11,000 near St. Louis, with rich agricultural country surrounding it; stock can be reduced; will give long lease on store building if desired; I have made money here and so can you. Address "E., 3495," care Jewelers' Circular-Weekly.

IF YOU HAVE a surplus stock of diamonds, watches or jewelry, send them to me and I will send cash for same; all business strictly confidential. E. Noel, 552 E. 46th Place, Chicago, Ill.

AT 50 CENTS on the dollar and less, corals, jets, ambers, plated and gold filled jewelry, solid gold baby pins, chains, etc., also a lot of diamond jewelry bought at trade auction sales; sent on memo. bills to well rated jewelers; sold for cash only. Address Dan I. Murray, broker and leading auctioneer of America, 3 Maiden Lane, New York.

FOR SALE, a nice retail jewelry and souvenir business, located on Penn. Ave., Washington, D. C.; stock over \$10,000; will reduce if desired; sale at inventory price or less if purchased outright; owner unable to give the business his personal attention, being disabled. Address "S., 3326," care Jewelers' Circular-Weekly.

FOR SALE, the well known plant of A. Lounsbury & Son, in full running order, with low rent, consisting of machinery, tools, dies, cutters, hydraulic press, drop presses, foot presses, upright drills, stock, office fixtures, safes, etc.; this plant is thoroughly equipped to make diamond mountings of all descriptions, both heavy and light, as well as fancy jewelry. Apply to Wales B. Lounsbury, 9 Maiden Lane, New York.

For Sale.

FOR SALE, jeweler's safe, inside dimensions, 24 x 27 x 30. Ford & Carpenter, 2 Maiden Lane, New York.

CHEAP, if sold soon, watchmaker's bench, lathe, complete set of tools and stock of materials; all in first class condition. O. G. Kelly, Easton, O.

FOR SALE, one complete set of fine watchmaker's tools, including Whitcomb lathe and attachments, bench wheel, etc.; list sent on application. Hengen-Bates Co., Baltimore, Md.

FOR SALE, one new improved Francis engraving machine, one Loring ophthalmoscope, one Javal ophthalmometer, two grindstones, one jeweler's roll, one lense drill. E. P. Bevilard, Albany, N. Y.

FOR SALE, platform scales, two dynamos for coloring room, three ft. press, gas furnace, electric furnace, rotary shears, four scratch brush heads, bench vise, air pumps. The Chas. M. Robbins Co., Attleboro, Mass.

JEWELER'S FIXTURES for sale; bargain; must be sold; seven straight show cases, one horseshoe case, six wall cases, solid mahogany, plate glass; condition A1; cheap if sold as a whole. For particulars, write Jno. S. Adams, receiver, Asheville, N. C.

To Let.

TO LET, half office or repair place, suitable for any trade. A. Hahn, Room 47, 37 Maiden Lane, New York.

PART OF OFFICE, with large front window, suitable for engraver, diamond setter or light repairing. Room 201, 79 Nassau St., New York.

PART of fine light diamond office, for manufacturer's representative; low rent to right party; 170 Broadway, New York. Address "O., 3427," care Jewelers' Circular-Weekly.

FIREPROOF LOFTS, reinforced concrete building, eight minutes from Maiden Lane, 150 feet from subway station, 41 x 95; elevator and heat. Address owner, Van Nostrand, 118 Chambers St., New York.

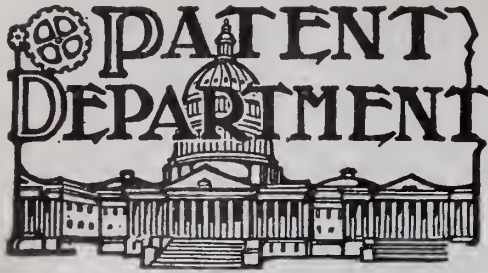

IN WHICH IS CONTAINED A LIST OF THE LATEST PATENTS GRANTED BY THE UNITED STATES AND GREAT BRITAIN, THE UNITED STATES PATENTS THAT HAVE EXPIRED AND THE REGISTERED TRADE-MARKS.

UNITED STATES PATENTS.

ISSUED FEB. 16, 1908.

879,170. BELL-CHIME FOR CLOCKS AND OTHER DEVICES. WILLIAM H. HOSCHKE, New York, assignor to the Sonora Chime Co., New York. Filed April 16, 1907. Serial No. 368,562.

A bell-chime comprising a plurality of bells ar-

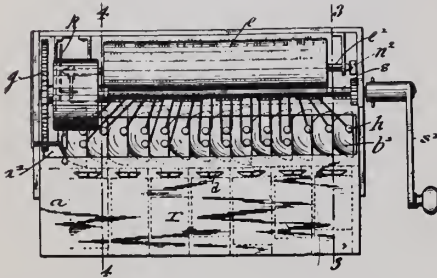

ranged in one row, and resonators for said bells arranged in rows adjacent the latter.

879,296. SELF-FILLING FOUNTAIN-PEN. FRANK H. MOONEY, Chicago. Filed Aug. 19, 1907. Serial No. 389,223.

A pen of the kind described, consisting of the barrel having a side aperture and interior tapering end; the penholder adapted to be rotatably supported in said end of said barrel, and to support a tube and ink chamber; the tube supported on said

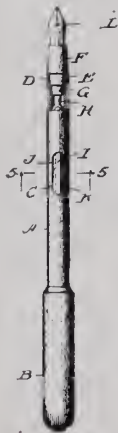

penholder, said tube being insertible in said barrel and rotatable therein, and having a side aperture adapted to register with said aperture in said barrel; and a collapsible ink chamber supported in said penholder and said tube; and the pressure bar affixed on said ink chamber adapted to be actuated by pressure applied through said apertures in said barrel and tube.

879,315. CLOCK. WILSON E. PORTER, New Haven, Conn., assignor to the New Haven Clock Co., New Haven, Conn. Filed Nov. 11, 1907. Serial No. 401,699.

In a variable signal clock, the combination with the center arbor thereof, of a notched signal wheel connected with said arbor for rotation thereby, a bearing-ring carried by the said signal-wheel with a space between the two wheels, a cut-out wheel provided with arms and differential notches, en-

tered into the said space between the signal-wheel and bearing-ring, a count hook coacting with the signal and cut-out wheels, and a setting-wheel con-

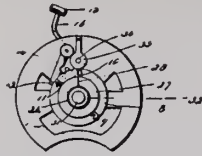

nected with the cut-out wheel for rotating the same and bearing upon the bearing-ring upon which it is rotated to position the said cut-out wheel.

879,358. PIERCELESS EAR-DROP. JOHN S. BRANT, Providence, R. I., assignor to the Cory & Reynolds Co., Providence, R. I. Filed Sept. 13, 1907. Serial No. 392,655.

As an improved article of manufacture the pierceless ear-drop herein described, the same consisting of a substantially U-shaped frame or yoke

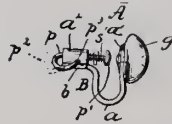

having one arm or member thereof provided with a setting arranged to carry a gem or ornament, an endwise movable spring-pressed retaining-bar carried by the other arm of said frame, said bar being disposed at the rear of and in substantial alignment with the said setting, and means for locking the bar when in its retracted or open position.

879,359. CUFF-PIN AND OTHER ANALOGOUS ARTICLE OF JEWELRY. JOHN S. BRANT, Providence, R. I., assignor to the Cory & Reynolds Co., Providence, R. I. Filed Sept. 13, 1907. Serial No. 392,656.

In a hinged cuff-pin or other analogous article of jewelry, the combination of front and tongue mem-

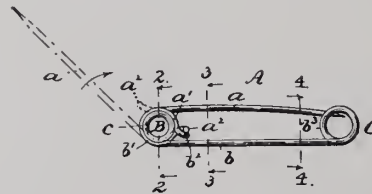

bers having the joint end portion of each of said members substantially alike and being disposed flatwise laterally against each other in different planes, a joint-pin engaging and supporting said end portions, and having the latter provided with integral lugs constructed and arranged so that when the pin is clasped the lugs yieldingly engage each other and impart a degree of resiliency to the pin.

879,410. ELECTRIC SIGNALING-CLOCK. HENRY S. PRENTISS, Elizabeth, N. J. Filed Aug. 4, 1905. Serial No. 272,715.

The combination with an electric signaling circuit

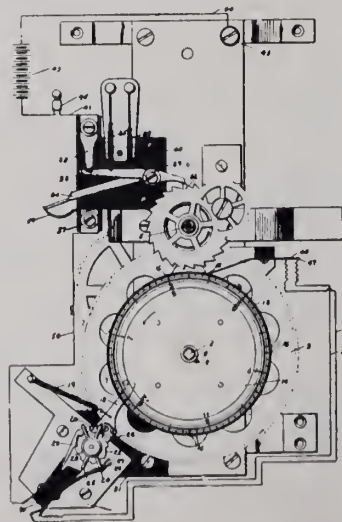

and a clock mechanism, of a disk or plate mounted

to be turned by said clock mechanism and provided with flexible circumferential contact teeth arranged for definite intervals of time, and which when in the plane of the disk are adapted to close said electric signaling circuit; a signal included in said signaling circuit; and a so-called scissor-switch in circuit therewith and comprising two levers having outer contact arms and inner arms of different lengths, said levers being controlled by said clock mechanism and adapted to limit the duration of said signal produced when said circuit is closed.

879,436. FOUNTAIN-PEN. GEORGE W. BENNUM, Georgetown, Del. Filed June 29, 1907. Serial No. 381,433.

A fountain-pen comprising an ink-reservoir, a feed device adapted to receive a supply of ink therefrom, a centrally-bored shaft within the feed device provided with means for controlling the supply of ink thereto, and a lug formed integra-



with said shaft and positioned contiguous said feed device and adapted for partial rotation, said lug abutting, at the limits of its rotation, the feed device for adjusting the supply-controlling means.

879,540. TIME SPEED-INDICATING DEVICE. EDWIN J. HALL, Waltham, Mass.; Anne I. Hall executrix of said Edwin J. Hall, deceased. Filed Aug. 14, 1905. Serial No. 274,061.

In a time speed-indicator, the combination with the center arbor of a clock movement, of a toothed gear secured thereto and thereby driven at a constant speed, speed indicating mechanism, and a variable speed, speed indicating mechanism, an

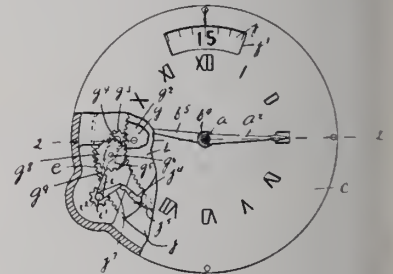

an actuating member for said indicating mechanism bearing a pinion which engages both said constantly and variably driven gears.

879,614. FOUNTAIN-PEN. SIGMUND H. ENGBERG, Brooklyn, N. Y. Filed March 6, 1907. Serial No. 360,910.

A fountain-pen having a barrel with the bore gradually diminishing diameter or tapered at its lower or pen end portion, and a feed bar lying partially within said tapered portion and adapted to fit the tapered portion throughout that portion



of its length which lies within the barrel so as to provide tight closure or fit.

879,626. FOUNTAIN-PEN. CHARLES W. GASTON, Allegheny, Pa. Filed Oct. 16, 1907. Serial No. 397,689.

A fountain-pen comprising a tubular handle piece forming a casing, a compressible ink-holding element therein, a pen attached to the handle piece, a feed tube connected with the ink-holding element and having its outer end spaced from the pen, and a tongue connected with the outer end of the

and curved toward the pen from the side of tube opposite from the latter for conducting



ink from the tube to the pen, the ink-carrying face of the tongue being smooth and straight in its reverse cross section.

379,817. ALARM CLOCK. JOHN R. HAUSCHILD, Eskridge, Kans. Filed Jan. 21, 1907. Serial No. 353,228. The combination with an alarm-clock, of a discharge tube operable by the verge-escapement of

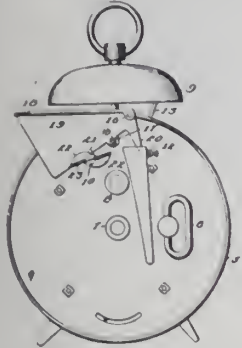

alarm mechanism, and a liquid reservoir operated intermittently by the alarm-wind mechanism.

39,665. TIME-RECORDING REGISTER. NORMAN S. McNAB, Canfield, and JOSEPH S. LINK, Melbourne, Victoria, Australia. Filed July 26, 1907. Serial No. 385,726.

In a workman's time-recorder, the combination of a minute recording typewheel; a sleeve on which a wheel is secured; an hour recording typewheel on said sleeve, and provided with a toothed wheel; a train of gears, one of the wheels of

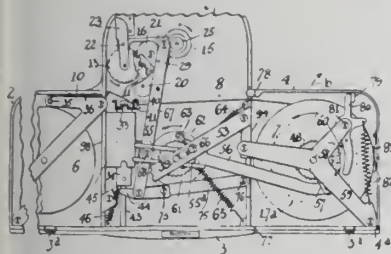

which is rigid with said sleeve; a clock mechanism; a clutch connecting the same with said train of gears; and means for locking and unlocking said toothed wheel, and for moving said wheel at intervals.

79,697. ELECTRIC CLOCK WINDING MECHANISM. ADOLF TRILKE, Eimsbüttel, near Hamburg, Germany. Filed Dec. 21, 1905. Serial No. 292,794.

In an electric clock winding mechanism, the combination with a plurality of wheel trains, of a spring-mounted weighted lever for each of

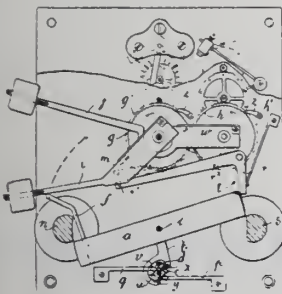

said wheel trains, an electromagnet, an oscillatory armature having a lifting arm extending into the path of travel of said weighted levers to be depressed thereby on the descent of the levers, and means operated by the armature for making contact when the armature descends to cause the electromagnet to oscillate the armature.

379,817. SELF-FILLING FOUNTAIN-PEN. PARKE P. FLOURNOY, Bethesda, Md.; assignor of one-twelfth to Parke P. Flournoy, Jr., one-twelfth to Benjamin C. Flournoy, one-twelfth



to Richard W. Flournoy, one-twelfth to Edmund S. Flournoy, one-twelfth to Addison H. Flournoy, and one-twelfth to Frank C. Flournoy, Bethesda, Md. Filed Nov. 20, 1907. Serial No. 403,038.

A combined closure and suction cap for self-filling fountain-pens having a portion of its length of contracted and thinner cross section and adapted to engage at that point only the exterior surface of a fountain pen barrel.

DESIGNS.

39,134. BADGE. HARRY L. DIEHL, Chicago.



Filed Nov. 8, 1907. Serial No. 401,345. Term of patent 7 years.

39,135. STICK-PIN. JOHN L. KEILMAN, Dyer,



Ind. Filed Jan. 7, 1908. Serial No. 409,721. Term of patent 3 1/2 years.

39,136. NECKLACE. CHARLES A. McDONALD, San Francisco, Cal. Filed Nov. 5, 1907.



Serial No. 400,891. Term of patent 3 1/2 years.

39,138. HANDLE, FOR SPOONS, FORKS OR SIMILAR ARTICLES. FREDERICK HABENSACK, Sag Harbor, N. Y., assignor to the



Fahys Watch Case Co., New York. Filed Dec. 26, 1907. Serial No. 408,200. Term of patent 7 years.

UNITED STATES TRADE-MARKS.

[The following trade-marks have been adjudged entitled to registration under the Act of Feb. 20, 1905, and are published in compliance with Section 6 of said act. Said section provides:

"Any person who believes he would be damaged by the registration of a mark may oppose the same by filing notice of opposition, stating the grounds therefor, in the Patent Office, within 30 days after the publication of the mark sought to be registered, which said notice of opposition shall be verified by the person filing the same before one of the officers mentioned in Section 2 of this act. If no notice of opposition is filed within said time the commissioner shall issue a certificate of registration therefor, as hereinafter provided for."

Marks which are stated to have been "Used 10 years" are registrable under the last proviso of Section 5 of said act, which is as follows:

"And provided further, that nothing therein shall prevent the registration of any mark used by the applicant or his predecessor, or by those from whom title to the mark is derived, in commerce with foreign nations or among the several States, or with Indian tribes, which was in actual and exclusive use as a trade-mark of the applicant or his predecessor from whom he derived title for 10 years next preceding the passage of this act."

PUBLISHED FEB. 18, 1908

Ser. No. **30,165.** (CLASS 27. HOROLOGICAL INSTRUMENTS.) CIE. DES MONTRES INVAR, Chaux de Fonds, SWITZ. Filed Sept. 23, 1907.

INVAR

Particular description of goods—Watches, watch cases and watch movements.

TRADE-MARKS REGISTERED FEB. 18, 1908.

67,762. JEWELRY. HANSEN-BENNETT Co., Providence, R. I.

Filed Oct. 14, 1907. Serial No. 30,592. Published Dec. 17, 1907.

BRITISH PATENTS.

(ABRIDGMENTS OF SPECIFICATIONS, 1906, FROM *The Illustrated Official Journal.*)

ISSUE OF FEB. 5, 1908.

22,619. WATCHES. E. A. RICHARD, 24 Cannon St., London. Oct. 12.

Keyless Mechanism.—Watches for outdoor use, as on motor cars or boats, are made with cylindrical cases fixed, with an annular interspace, within an outer casing which carries the bezel. The bezel

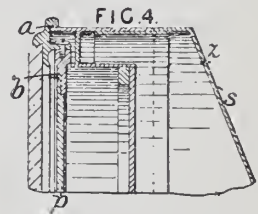

a is made rotatable and has an annular rack *b* attached to it, which meshes with the pivot wheel of the rocking-bar gear for winding and hand-setting. The annular rack is held on the top-plate of the movement by a disk *p* screwed to the frame or plate thereof.

Cases.—The outer case fits a holder *s* permanently attached to the vehicle or boat, and is secured by a bayonet-joint, with a spring catch which must be pushed back by a small key.

22,707. DISPLAYING GEMS. C. MOE, 82 Adams



St., Chicago, U.S.A. Oct. 13. A ring for displaying gems is formed so that

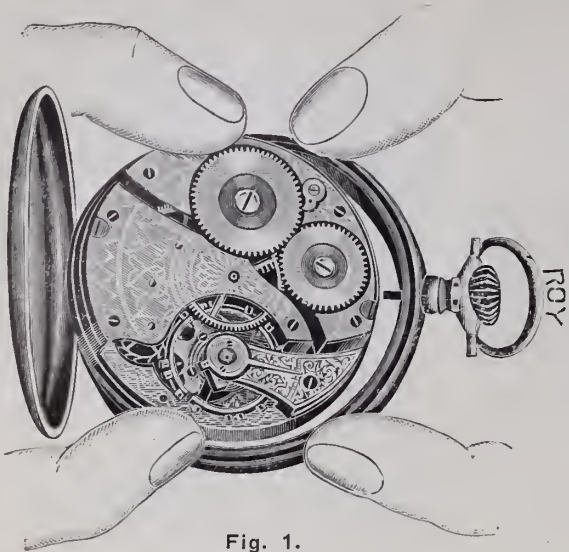

Fig. 1.

The
Ægis
 Case
 Patented

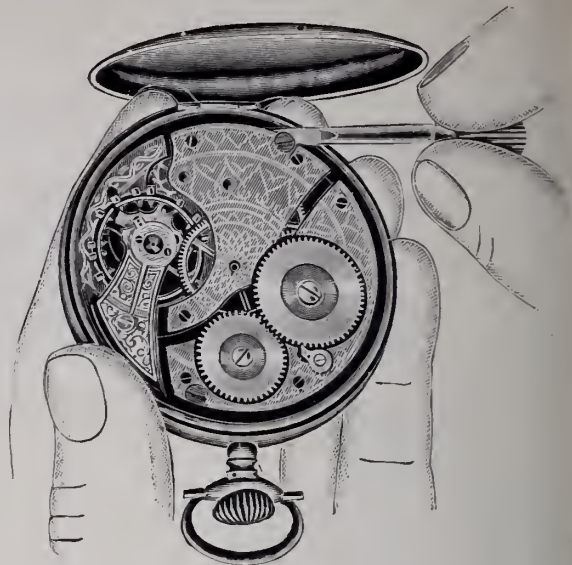

Fig. 3.

¶ The Ægis is a new creation in gold case making. The center and bezel are in one. Instead of having the ordinary Cap, this case is provided with a rigid metal movement Cup, held friction tight in position. This Cup gives protection to the movement such as cannot be secured with the conventional jointed cap, while dust is thoroughly excluded from the front by means of the one piece center and bezel.

¶ To fit movement, first properly adjust the hands; then pull out crown as usual, and insert movement from back of case, (see fig. 1). After winding square is properly fitted, the movement should be pressed down, so that it will be held in proper place by the spring in the case center. The movement cup should then be fitted.

¶ To take out movement, remove the movement cup (shown in fig. 2), by raising it near the pendant; pull out crown to release the square; lift out movement by means of case screw nearest joint (see fig. 3); withdraw movement from square and case.

Made only
 by



Fig. 2

Made only
 by

ROY WATCH CASE COMPANY

SAN FRANCISCO OFFICE
 704 Market Street

21-23 Maiden Lane
 NEW YORK

he prongs 3, which act as the setting, can be prung to hold various-sized gems.

Complete specifications accepted Jan. 22, 1908.
1907.

119. ELECTRIC CLOCKS. PARSONS & BALL.
1,240. ELECTRIC TIMEPIECES. MOLLER.
1,500. MANUFACTURE OF PENDANTS. BAKER.
1,750.7. CANDLESTICK. McMULLEN & BARNES. Applications filed Jan. 13 to Jan. 18, 1908.
1,746. EYEGGLASSES. HENRY ASTON, Birmingham.
1,750. PIN. JEANIE MACDONALD, Southport, Lancaster.
1,773. CLOCK REGULATOR. THOMAS ADAIR, Belfast, Ireland.
1,805. KEY RING. C. S. FORBES. London.
1,866. FOUNTAIN-PEN. F. C. JARVIS and T. H. GARNER, London.
1,837. HAIR-PIN. AMY D. PEACOCK, Earl's Court, London. Complete specification.
1,015. COLLAR-BUTTON. G. L. M. DOBLER, London.
1,052. JEWELERS' CLIP. TOM BATES, London.
1,061. SPECTACLE FRAME. F. W. BATEMAN, London.
1,149. THIMBLE. C. E. ILES, Birmingham.
1,259. WATCHHOLDER. A. E. PEARSON, London.

Complete specifications accepted Jan. 29, 1908.
1907.

- 1,514. COLLAR BUTTON. JOWETT.
1,188. BRACELET. FREIVOGEL.
1,1083. CRUMB SCOOP. DEAN.
16,790. STUD. ADLER.
22,650. WATCH. MONTANDON-BANDELIER. Applications filed Jan. 20 to Jan. 25, 1908.
1,303. CLOCK. PIERRE POETTO, London. Complete specification.
1,315. HAT-PIN. L. F. PILKINGTON, London. Complete specification.
1,338. CHAIN SUSPENDER FOR UMBRELLA HANDLES. G. A. GOODWIN, London.
1,345. FOUNTAIN-PEN. A. F. ZAHM, London. Complete specification.
1,379. POCKETBOOK. CHARLES LAVENDER, Birmingham.
1,411. HAIR ORNAMENT. IDA BECKER, London.
1,495. BELT. A. D. BATEMAN, Manchester.
1,497. EYEGGLASSES. HENRY ASTON, Birmingham.
1,679. HAT-PIN. ANNIE PATTSON, London.
1,701. FOUNTAIN-PEN. R. C. ELLIOTT, London.
1,703. PENHOLDER. W. S. WIDGER, London.

UNITED STATES PATENTS THAT HAVE EXPIRED.

[Reported especially for THE JEWELERS' CIRCULAR-WEEKLY by R. W. Bishop, Patent Attorney, Washington, D. C.]

Issued Feb. 17, 1891.

- 146,542. UMBRELLA OR PARASOL. C. J. SWART, Goshen, Ind.
146,543. BUCKLE. J. A. TRAUT, New Britain, Conn.
146,564. CLASP. S. B. BACON, Waterbury, Conn., assignor of one-half to C. M. Upson, same place.
146,591. INKSTAND. C. E. BLUE, Wellsburg, W. Va.
146,593. CHAIN FASTENING. B. S. FREEMAN, Jr., Attleboro, Mass.
146,611. OPERA GLASSES. C. A. PERKINS and W. H. H. NORCROSS, Boston, Mass., assignor to G. H. Eaton & Co., same place.
146,618. SEAMLESS COMPOUND WIRE. L. L. BURDON, Providence, R. I., assignor to the Burdon Seamless Filled Wire Co., same place.
146,619. METHOD OF PRODUCING SEAMLESS COMPOUND WIRE. L. L. BURDON, Providence, R. I., assignor to the Burdon Seamless Filled Wire Co., same place.

- 446,646. PENHOLDER. F. J. KALDENBERG, Tarrytown, N. Y.
446,680. COFFEE OR TEA STRAINER. HENRY HANNIG, Paterson, N. J.
446,721 and 446,722. BUCKLES. J. A. TRAUT, New Britain, Conn.
446,737. WATCH CASE. E. F. HEFFERNAN, Toronto, Can.
446,774. FOLDING CUP. H. R. HAYNES, Westminster, Mass.
446,804. ELECTRIC REGULATING-CLOCK. D. and G. VANDE PLANCKE, Courtrai, Belgium.
446,840. SUSPENDERS. F. H. RICHARDS, Hartford, Conn., assignor to the Traut & Hine Mfg. Co., New Britain, Conn. Design issued Feb. 19, 1901, for 7 years.
34,093. HAIR-CLASP. F. H. BUZZACOTT, Chicago.
34,095. DECANter. A. D. ST. GEORGE, Chicago. Design issued Aug. 16, 1904, for 3½ years.
37,089. BRUSH-BACK. W. H. BLAKE, Attleboro, Mass., assignor to the J. E. Blake Co., Rhode Island.

Some Newspaper Comments on the Anniversary Number.

ANNIVERSARY NUMBER.

THE JEWELERS' CIRCULAR-WEEKLY HAS JUST ISSUED ITS LARGEST AND BEST EDITION.

"Local jewelers have just received the 39th anniversary number of THE JEWELERS' CIRCULAR-WEEKLY, which, by the way, bears the distinction of being the largest and most handsome publication of its kind ever received in Toledo.

"This number, which contains 254 pages, is not only one of the largest that has ever been issued by any publication of its character in the jewelry trade, but both as a magazine and as a volume of interest to the jeweler, fittingly represents the progress of the times and the importance of the jewelry trade in the commercial world. The amount of advertising it contains establishes a record also, being the largest the firm ever published.

"Beginning with the beautiful front cover and ending with the last page of the book, the issue will be found interesting and instructive to the subscriber, no matter what his line may be, while the retail jewelry merchant will find a number of articles which will be a decided help to him in his business and trade, and others that will give him points which he can directly apply to his business and also give him information of his craft which has never before been placed at his disposal."—Toledo O., *Courier Journal*.

CIRCULAR-WEEKLY CONGRATULATED.

"The *Sun* extends its congratulations to THE JEWELERS' CIRCULAR-WEEKLY not only because of that publication's 39th anniversary, but also because of the anniversary number of 254 pages, an excellent example of the printing art as well as an especially interesting number."—Attleboro *Sun*.

IS A FINE BOOK.

"Local jewelers have received their current copies of the 39th anniversary number of THE JEWELERS' CIRCULAR-WEEKLY, which is one of the most attractive issues ever gotten out by the enterprising firm. The book, as it may be called, is of 252 pages and is elaborately and profusely illustrated. The cover design of two peacocks is remarkably beautiful."—Pawtucket *Times*.

A GREAT EDITION.

"THE JEWELERS' CIRCULAR-WEEKLY, one of the official organs of the jewelers, is to be congratulated on the 39th anniversary edition just issued. The cover design is truly a work of art and the magnitude of the book is almost marvelous when the fact is taken into consideration that it represents a single industry. We are pleased to speak a few words of praise for the modernism of the publication."—North Attleboro *Chronicle*.

TRADE PUBLICATION ISSUES FINE NUMBER.

"The 39th anniversary number of THE JEWELERS' CIRCULAR-WEEKLY, one of the leading weekly trade publications, is a fine sample of the engraver's art and contains some very interesting articles on historic jewelry. The frontispiece, detailed in rich colors, represents two peacocks in full plumage

holding a jeweled pendant supported between them. The heads of the birds surmounted by the pretty crown feathers stand out in bold relief against golden disks. The magazine contains 250 pages of advertising and reading matter."—Detroit, Mich., *Journal*.

TRADE PAPER'S BIRTHDAY.

"The current issue of THE JEWELERS' CIRCULAR-WEEKLY marks the 39th anniversary of that publication, and the event is appropriately celebrated with a special edition of 252 pages. There is an attractive cover design by Hans Brazzler and an interesting article on "The Municipal Plate of the Cities of Europe," illustrated by a score of photographs. The programmes of the coming convention of the Indiana Retail Jewelers' Association to be held here Feb. 18 and 19 is given, and there is also a news letter from this city."—Indianapolis *Star*.

FINE ISSUE OF THE JEWELERS' CIRCULAR-WEEKLY.

"The 39th anniversary of THE JEWELERS' CIRCULAR-WEEKLY, the current issue, is the largest magazine ever issued by this trade's journal to the present time since it was in the field as a weekly journal. The magazine has just been received in this city by the local jewelers and all have expressed themselves as being delighted with the paper. Two hundred and fifty pages on fine paper, with a large amount of excellent reading matter, constitute the contents. One of the noticeable features this week is the unusually large run of advertising matter, which sets a new record for the paper. The cover is printed in three colors and is a handsome creation by Hans Brassler. The municipal plates of several of the leading cities of Europe are shown by illustrations, and several pages are given over to illustrations and a well prepared story on the trend of fashion in jewelry. By photo-engravings and reading matter the gold and silver treasures of the royal house of Hohenzollern, one of the oldest reigning houses of Europe, are shown."—Springfield, Ill., *Register*.

Sir Julius Wernher on the Conditions in the Diamond Trade.

ACCORDING to a recent issue of the *Frankfurter Zeitung*, to a representative of the German diamond trade in interview in Paris, Sir Julius Wernher stated that the principal concern of the De Beers company and the diamond syndicate has always been their customers. If the prices were reduced the customers would be weakened, but the company and the syndicate were interested in strengthening their clients. This was the reason for restricting production at the mines, and De Beers and the Premier companies had therefore withheld the dividends. It was obvious that recent years were under the influence of the high period of prosperity, and it was consequently natural that with a return to normal times the consumption of diamonds would also move in a normal way.

The Premier Mine had started working in a brilliant time, without intimate knowledge of the diamond trade as such, and had believed that the market would be able to absorb any quantity also in less favorable periods. But the directors of the Premier Mine had perceived that the policy of De Beers and the syndicate in the direction of regulating the output according to the demand was the only correct one, and they had also made that policy their own.

In conclusion, Sir Julius remarked that the diamond branch could look to the future full of confidence, and the syndicate would under no circumstances reduce its prices.

The Strange Jewelry Co., Sherman, Tex., has increased its capital stock from \$20,000 to \$30,000.



WALTHAM JEWEL SERIES WATCHES

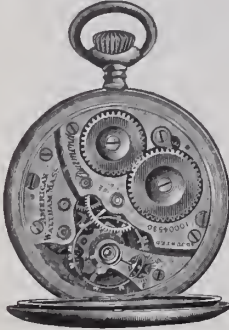

DIAMOND; NICKEL;

17 diamond and ruby jewels; both balance pivots running on diamonds; raised gold settings; steel escape wheel; exposed sapphire pallets; compensating balance, adjusted; meantime screws; patent Breguet hairspring, hardened and tempered in form; patent micrometric regulator; tempered steel safety barrel; gold train; exposed winding wheels.

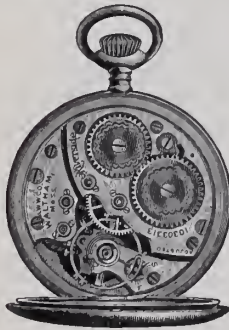

RIVERSIDE; NICKEL;

17 fine ruby jewels; raised gold settings; steel escape wheel; exposed sapphire pallets; compensating balance, adjusted; meantime screws; patent Breguet hairspring, hardened and tempered in form; tempered steel safety barrel; red gold center wheel; exposed winding wheels.

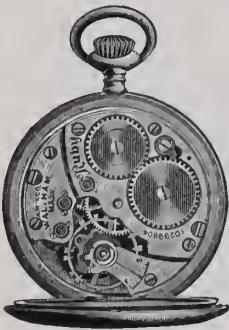

RUBY; NICKEL;

15 jewels; raised settings; exposed pallets; compensating balance; meantime screws; patent Breguet hairspring, hardened and tempered in form; tempered steel safety barrel; exposed winding wheels.

HUNTING OR OPEN FACE

These movements may be obtained in a great variety of Gold Cases, from Plain Polished to the most elaborately Engraved, Carved and Enameled.



Movements Manufactured and Guaranteed by

WALTHAM WATCH COMPANY
WALTHAM, MASS.



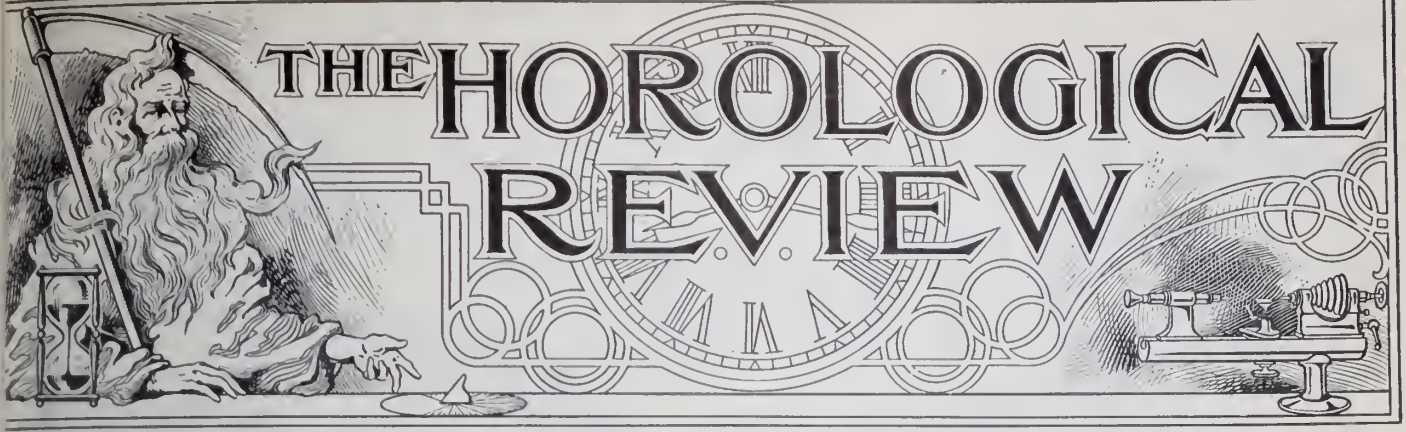

THE HOROLOGICAL REVIEW

The Mainspring and Its Dimensions

By Jean Peitavel, Director of the Horological School at Fleurier

WHEN the young watchmaker has learned that the diameter of the barrel must equal one-third of the inside diameter of the barrel, and that the part of the barrel taken up by the spring ought to be about equal to the remaining part in order to give the greatest number of turns or uncoiling, he in most cases imagines that he has exhausted the subject and that he can stop with that information.

The question, however, is not wholly disposed of with those simple data, and it is evident to everyone who has read the studies made on this subject by competent authors, such as Mr. Grossmann in his course on the theory of watchmaking, or the study published by the *Journal Suisse d'Horlogerie*, having for its title "The Barrel of the Watch and the Mainspring," that a new axis must be laid down.

The development of the manufacture of watches to run a long time without re-winding certainly must have brought a number of watchmakers face to face with this question, and it would not be surprising if many of them, finding its limits too narrow, had thrown overboard the simple data to adopt arbitrary proportions.

H. Grossmann, in his course above mentioned, has inquired with great care into the limits within which is comprised the ratio between the thickness of the spring and the diameter of the collet, and the importance of this ratio is such that it seems to us it ought henceforth to be the basis of the dimensions of the motive organ.

For reasons which it would require too much space to develop here, but which the reader will find in the course above mentioned, a single ratio cannot suffice for all the dimensions of barrel which occur in pocket watches; but it might well answer for several consecutive sizes, such as from 7 to 22 lignes, for instance.

The authors who have treated this subject are far from being in accord in respect to the value of this ratio. According to L. A. Groslande's table of dimensions for watch springs, for the maximum number of coils, say five, the diameter of the collet would be 24 times the thickness of the spring. Messrs. Rosé, in a work on the subject, give for the minimum diameter of the collet 26 times the thickness of the

spring, and Mr. Grossmann, relying on very careful calculations, gives the collet's diameter as 32 times the spring's thickness.

If we ask some of the manufacturers what ratio they have adopted in practice we shall get various answers, as the following shall get various answers.

To be sure there is a great difference in the quality of the springs; therefore the degree of temper will be the first factor to take into consideration in order to fix the

$\left(\frac{2r}{e} = 30\right)$ for an interior diameter of barrel equal to 1, and for coils ranging in number from 4.4 to 11.5.

Ratio between diameter of barrel and thickness of spring. $\left(\frac{2r}{e}\right)$	Diameter of collet. (2 r)	Thickness of spring.	Length of spring.	Number of coils in the spring when unwound. $N' = \frac{R-r'}{e}$	Number of coils in spring when wound around collet. $N'' = \frac{R-r''}{e}$	Number of coils used in unwinding. $\Delta = N'' - N'$
80	0.375	0.0125	29.6	10.8	15.2	4.4
82	0.366	0.0122	30.12	11.1	15.8	4.7
84	0.357	0.0119	31.10	11.5	16.5	5.0
86	0.349	0.01163	31.9	11.8	17.2	5.4
88	0.341	0.01136	32.76	12.1	17.9	5.8
90	0.333	0.01111	33.5	12.45	18.6	6.15
92	0.326	0.01087	34.4	12.8	19.3	6.5
94	0.319	0.01064	35.3	13.1	19.9	6.8
96	0.312	0.01042	36.2	13.4	20.5	7.1
98	0.306	0.0102	37.1	13.7	21.2	7.5
100	0.300	0.0100	38.0	14.1	21.9	7.8
102	0.294	0.0098	38.8	14.4	22.6	8.2
104	0.2886	0.00962	39.6	14.7	23.2	8.5
106	0.283	0.00943	40.4	15.0	23.9	8.9
108	0.278	0.00926	41.2	15.3	24.6	9.3
110	0.273	0.00909	42.1	15.6	25.3	9.7
112	0.268	0.00893	43.0	16.0	26.0	10.0
114	0.263	0.00877	43.9	16.3	26.7	10.4
116	0.2586	0.00862	44.7	16.6	27.3	10.7
118	0.254	0.00847	45.4	16.9	28.0	11.1
120	0.250	0.00833	46.2	17.2	28.7	11.5

SOME DIMENSIONS OF THE MOTIVE ORGAN OF WATCHES.

ratio. It will readily be understood that if the ratio be too great the resulting number of coils to be unwound will be diminished, while if the ratio be too small there is danger either of breakage of springs or a too pronounced permanent mis-shaping.

Having taken all these things into consideration, we can adopt a diameter of collet equal to 30 times the thickness of the spring with the certainty that this proportion is adapted to springs of good quality.

The adoption of such a ratio now admits

the establishing of a table of dimensions of the motive organ for a series of numbers of turns for uncoiling, and it will be remarked that the diameter of the collet increase at the same time with the thickness of the spring. In a single case only will the diameter of the collet be found equal to a third of the interior of the barrel, to wit, the one which gives 6.15 coils for unwinding.

The computations have been made by means of the formulas of the Grossmann course, modified, however, in respect of the value N of the number of coils for unwinding. By the formula

$$N = \frac{1}{e} \left(\sqrt{R^2 - r'^2} + r^2 - r - R + r' \right)$$

we obtain a theoretical result which is too

high, and which practice does not confirm, because the part of the coil which detaches itself from the unwound spring to go to the hook of the collet is not taken into account. In order to take into account this part of the coil, equivalent to a half or three-quarters turn, we have diminished r', the radius of the first coil of the unwound spring, by the quantity e, the thickness of the spring, and we have taken $r' + e = r''$, as the radius of the last coil of the spring when wound, the radii r' and r'' having

SELLING TIME

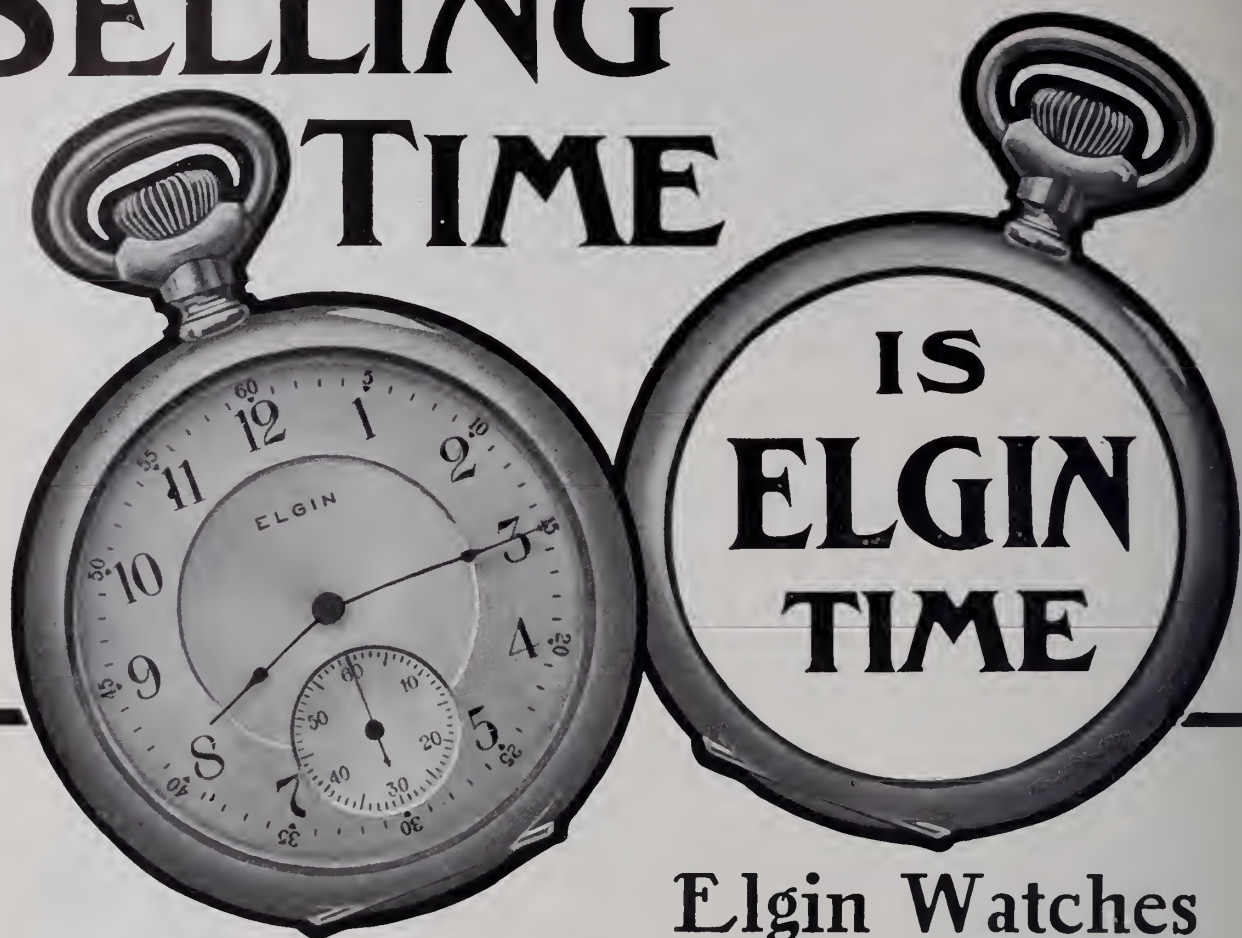

Elgin Watches Know No Season

They are quick sellers all the year round. The demand is steady and constantly increasing. Dealers who carry a full stock of ELGINS are reaping the benefit of our extensive newspaper and magazine advertising.

Is your line complete?

The G. M. WHEELER Grade ELGIN, "*The Watch That's Made for the Majority,*" meets the great demand for a reliable watch at a popular price, and can now be had in various sizes and stylish thin models for men's and boys' use.

See jobbers' list for prices or write the Company.

The Elgin Art Booklet, "*Timemakers and Timekeepers,*" is yours for the asking. Send for it.

ELGIN NATIONAL WATCH COMPANY,

Factories: Elgin, Ill, U. S. A.

General Offices: 131 Wabash Ave., Chicago.

New York Office: 11 John St.

San Francisco Office: 704 Market St.

en obtained by means of the formula

$$r' = r'' = \sqrt{\frac{R^2 + r^2}{2}}$$

which gives the maximum of coils for un-

winding. The difference which is found between the number of coils of the unwound ring, that is, $N' = \frac{R-r}{e}$, and the num-

ber, N'' , of coils of the spring completely wound up around the collet, that is, $N'' = \frac{r''-r}{e}$, gives the number, N , of coils unwound during the unwinding of the spring, that is, $N = N'' - N'$.

In the formulas above given R equals the radius of the interior of the barrel, and r the radius of the collet.

All the values in this table having been calculated on the basis of 1, or unity, as the internal diameter of the barrel, to use the table it will only be necessary to find first, in the column N , the number of coils required, then measure the interior diameter of the barrel and use this value as a multiplier of all the factors relating to the number of turns required—that is to say, the diameter of the collet, and the thickness and length of the spring.

The following example will make the use of this table more intelligible.

Let it be supposed that the interior diameter of the barrel is 21.5 mm. and that 7.1 coils for unwinding are desired.

The following dimensions will be obtained:

Diameter of collet = $0.312 \times 21.5 = 6.708$ mm.
 Thickness of spring = $0.01042 \times 21.5 = 0.224$ mm.
 Length of spring = $36.2 \times 21.5 = 778.3$ mm.

No surprise should be felt if the data in the table be not always found exact; the relations which subsist between the dimensions of the spring, on the one hand, and the diameters of the barrel and the collet, on the other, are extremely variable and cannot be expressed with exactness. Moreover, it will be remembered that a variation of 0.01 mm. in the thickness of the spring will give rise to a variation of at least a third of a coil in the number of coils for unwinding, the other dimensions remaining unchanged.

Before terminating this study there remains one observation to add. If the use of long springs, giving a number of unusual coils, be justifiable in certain cases, it is not at all to be recommended from the point of view of the delivery of motive force. It is true that this force will be less unequal between the first and the last coils of the winding than in the case of a shorter ring, but the friction between the coils absorbs a considerable part of the force of the spring.

We give below a summary of tests made with an apparatus for measuring the loss of power in springs:

Length of Spring.	Number of coils unwound.	Loss by friction expressed in per cent. of motive force.
994	10.5	29.0 Per cent.
990	10.7	23.0 "
790	10.2	16.3 "
572	9.0	14.8 "

Clock of the Louis 16th Period.

(Translated expressly for THE JEWELERS' CIRCULAR-WEEKLY from the Leipziger Uhrmacher Zeitung.)

ONE of the best specimens of the art style of Louis XVI., which style is known for its strict forms, wherein it differs from previous artistic productions, is the handsome mantel clock illustrated below. According to the inscription on the gold plate attached to its front, this clock belonged to Queen Marie Antoinette, of France. The principal part of this magnificent piece is made of lapis lazuli, which is ornamented with different precious stones.

The urn contains the clock movement, which indicates the time on an artistic dial,



MANTEL CLOCK OF LOUIS XVI. PERIOD

represented by two metal bands, of which one indicates the minutes and the other the hour.

These bands rotate around the body of the vase, and show the time under the tongue of the serpent, the symbol of eternity. On a medallion located on the base is an emblem surrounded by precious stones and representing a quiver, a flambeau and a love knot, the meaning of which cannot be deciphered at present, but which may be symbolical of some sentimental event of the times, where emblems and categorical displays were the order of the day.

However indifferently we may regard these art indulgences at the present day, we must admire the rich and high art displayed in these symbolic expressions, which alone should form a study of its intellectual leaning, which shows a distinct preference for flat and form-giving lines. This is

shown most forcibly in the handles of the vase and the sinuous curves of the serpent. In like manner the elliptically formed medallion on the base shows its characteristic tendency.

In a general aspect the distinguishing feature of the style of Louis 16th impresses itself on art students when compared with the Renaissance. Where the latter indulged in circular lines, the former prefer the compressed "volute." When we manifest our partiality for pendants and circumscribe the use of meaningless ornaments, we have characterized the most important points in the style of Louis 16th.

Defects in Electrical Clocks.

WHEN an electric clock, says H. Krapp in the *Leipziger Uhrmacher Zeitung* (a secondary clock is, of course, referred to), fails to keep accurate time, the following defects may have occurred: (1) the battery may be too weak; (2) the conductors may be faulty; (3) the contacts of the master clock may not work; (4) the magnet coils of the secondary clock may have a short-circuit or a coil wire may be broken; (5) the mechanical works of the secondary clock may be faulty.

For these purposes four 25-cell bag batteries, with zinc cylinders, will be found most suitable. I prefer these to dry batteries. If these bag batteries have lost their strength and show less than one volt per cell, they should be taken apart, the zinc scraped clean inside and out and new solution supplied to each cell. In each jar put 200 grammes of sal ammoniac, half fill it with warm water, and when solution is complete replace the carbon bag and zinc cylinder. Carbon and zinc must not be in contact and the binding posts must invariably be dry and clean.

To locate defects 2, 3 and 4, a testing apparatus is necessary. Such an apparatus consists of a small battery and a sensitive galvanometer.

To test the conductors we suspend the apparatus directly in the wires leading to the secondary clock. The wire to the secondary clock is disconnected and the pointer must then remain at O. If we allow the two wires of the secondary clock to be temporarily connected, the conductors, or in other words, the circuit, will be closed and the pointer of the testing apparatus must be vigorously deflected until the two wires are again separated. If this does not occur, there is something wrong with the conductor wires, or if it is in any way possible, it will be as well to equip the secondary clock with new wires (1.5 mm. diameter copper, vulcanized cores).

To test the contacts of the master clock, we attach the testing apparatus directly to it. When at rest, the needle must not be deflected, but must remain stationary on O, as though the apparatus had not been cut in. When contact is, however, made by the master clock (which should take place, as a rule, every minute) the needle must be vigorously deflected and return at once to O. Should this not be the case, and if the deflections of the needle are weak, the contact points should be brightened. If this effects a remedy we shall recognize the fact by the needle being vig-

JAS. BOSS

Stiffened Gold Watch Cases

(Guaranteed for 25 Years)



F. 3188



Trade-Mark in Back



Trade-Mark in Cap



F. 3344

NEW DESIGNS IN 16 SIZE

The popular watch for gentlemen.

F 3188. Rich and elegant effect on the order of the standard "top and bottom" engraving.

F 3251. Another and slightly more elaborate variation on the "top and bottom" order.

F 3344. Fancy engraved. Beautiful combination of Barley Corn, Ray lining, Vermicelli, Bright Cutting and Landscape.

F 2953. A good illustration of effect obtained by using Brocade work in connection with the old-established methods of ornamentation.

These are only a few suggestions from our line, which must be seen to be appreciated

SOLD BY ALL LEADING JOBBERS



F. 3251



F-2953

The Keystone Watch Case Co.

Philadelphia

New York
Chicago

Boston

Cincinnati
San Francisco

ously deflected and then returning at once to O. If, however, the needle is permanently deflected, we are confronted with short circuit in the master clock. There is either a contact where one should not exist or both contacts are inadequately insulated, as regards each other. This fault must also be remedied until the needle acts properly, as described.

If, then, the mechanical works of the secondary clock have been overhauled and proceed in order, the fault can only be with the electro-magnet coils of the secondary clock, and there remains nothing to be done but to return the movement of the secondary clock to the factory.

Watch Repairing.

By H. REINECKE.

(Continued from issue of Feb. 12.)

THE subject of isochronism in the motion of a balance in a watch has been under discussion in one or two previous issues of THE CIRCULAR-WEEKLY, but as such discussion has been rather theoretical it may have generated the desire on the part of watch repairers to learn something more practical on the subject. Hence the following is brought forward to meet such a desire, at least in part.

The whole subject of isochronism was brought into prominence by the inventors and manufacturers of marine chronometers, and its importance has been perpetuated by its application to pocket watches. Balance springs producing isochronism were at first made of some special forms, but more commonly when applied to a large number of watches they were made in the more convenient form of a flat spiral. In these it was recognized that such could be made of number of coils not specially determined, of which each coil had an isochronal point, which was found by practical tests to be conditioned by the relative location of their points of attachment.

Assuming that the point of attachment of the inner coil of the spiral at the collet, so called, and of the outer coil at the stud enclose a number of full circular coils, we express such condition by saying the points of attachment are opposite to each other. When this condition exists in the position of the balance spring, when applied to the balance in a watch, it becomes necessary to take notice that its position has been modified by the position of the regulator pins, which represent a secondary stud for the purpose of shifting. This causes the assumption that the location of the stud is somewhat between the two points. As a general rule, every increase of the length of the spring by shifting the point of attachment at the stud will influence the isochronism to be changed and cause the watch to gain in the short vibrations; every decrease in length of the spring will cause the watch to gain in the long vibrations. This mode of adjustment is limited to one-half of a coil, to be measured when the points of attachment are opposite to each other, either on the inner or outer coil.

The difference in the timekeeping of a watch produced by such an operation must always be corrected by changing the weight of the compensation balance. The difference in the time in the long and short vibra-

tions by the extreme of such an adjustment may be from 20 to 25 seconds, but the nearer the points of attachment can be kept opposite each other, the less eccentric will be the expansion of the balance spring, which has always to be reckoned with.

It is obvious that the same result may be reached, whether we change the length of the spring, its points of attachment or the inner or the outer coil. The preference of the latter is in order when it is an object to avoid too much change in the timekeeping conditions, as these are changed less by circular proportions.

Circumstances should be the guide of an operator. It is not to be inferred that the flat spring has been superseded by the Breguet spring, because the latter produces a better timekeeper. Such is not the case, but it is only preferred on account of its more convenient form and facility of adjustment. On the other hand, the flat spring is more favorable to permanent good timekeeping when once adjusted, as it retains its elasticity after having been hardened and tempered, while a Breguet spring is strained, bent and unbalanced in its general applications and adjustments. The circular position adjustments with a flat spring are more tedious and require more skill, as they are made by the adjusting of the inner coil around the collet, after it has been pinned to it. This may be done by the small eye of a needle, of which the temper has been drawn and the extremity of the closed part of the eye filed off and the sharp corners removed.

For such adjustments in positions the watch repairers require skill and experience. On the other hand, such adjustments may be of use in an obstinate case of adjustments with a Breguet spring. Considering the latter, it has been said with a great deal of force by the English watch adjusters in competitive trials with the helical springs that Breguet springs should not be applied with regulators and should not be bent after hardening. That this subject has been seriously considered may be inferred from the awarding of a premium by the British Government to E. J. Dent for the unequalled steady performance of a chronometer which varied only 0.54 of a second from its rate during a public trial of 12 months.

For the further study of this subject a perusal of the published expressions of celebrated horologists is to be recommended.

(To be continued.)

The establishment of H. R. Millard, Montreal, Que., was considerably damaged by fire, Feb. 13.

The jewelry stock of Jacob Gruesen, W. Superior St., Duluth, Minn., was sold recently by W. G. Good to W. Reinhart for \$11,698. Mr. Gruesen applied to the United States Circuit Court for bankruptcy, and on application of the creditors Judge Page Morris ordered that the stock be sold as soon as \$9,000 or more could be gotten for it. The price brought by the stock will allow the creditors to receive 47 1/4 cents on the dollar. The principal creditors are: S. Langsdorf & Co., Keller Jewelry Mfg. Co., Sischo & Beard, International Silver Co., Watcon & Newell Co., New Haven Clock Co.

Horological Notes.

THE Annual of Watchmaking Establishments for the year 1908 has just been issued by the International Advertising Co., Ltd., of Neuchatel, Switzerland. The volume, which measures nearly eight and one-quarter inches by 11 1/2 inches, contains over 350 pages, neatly bound in enameled paper and cloth. The front cover page shows a half-tone reproduction of the famous painting "Industry," by Paul Robert, which is at present on exhibition in the Museum of Fine Art, in Neuchatel. A fine quality of coated paper is used for the pages, which are well printed in easily readable type. As an annual index and review of matters horological this edition is of much value to those branches of business which have any interest in the commercial and industrial development of horology. It embodies the names and location of manufacturers of watches, tools and material in three distinct alphabetical lists. It contains also complete explanation of the fineness of the precious metals employed in horological products, and speaks of all subjects of interest to the members of the branch, in whose interest it has been published. The book is distributed free to purchasers of watches and watchmakers' supplies upon remitting to the editors the price of mailing, which is one franc.

When the tower of the Metropolitan Life building in Madison Square is completed New York will have what undoubtedly will be the largest clock in the world. That distinction has belonged for many years to "Big Ben," in Westminster Abbey, London, the dial of which is 22 1/2 feet in diameter, while that of the Metropolitan building clock will be 25 feet. It will be a clock suitable in every way to be a part of the tallest permanent structure in the world, as the new tower will be. The tower will be 48 stories, 658 feet above the street, and the clock will occupy part of the 25th, 26th and 27th floors. The middle of the dial will be 346 feet above the street. Notwithstanding the fact that the dial will be a little more than half way between the street and the top of the tower, it will be far above all surrounding buildings. It will be 50 feet higher than the Flatiron building. The immense size of the clock will make it easy to tell the time from a great distance. The letters on the dial will be four feet high and the hands will be 12 feet long. No clock has been ordered for the building yet, and it is not known just how it will be run. Some of the largest clocks are run by electricity, while some of the newer ones use compressed air.

Edwin A. Perry, for nine years superintendent of the Pairpoint Corporation, New Bedford, Mass., is now making silverware in South Carolina, where he is the active manager of the Eastern Carolina Silver Co. Mr. Perry was connected with the Pairpoint Mfg. Co. for 24 years. One year ago he became interested in Hartsville, S. C., as a desirable place for a silver and plated ware factory. With this purpose in view he resigned from the Pairpoint concern and in company with Andrew Lowden, as mold maker, went south and started a business there.

For the Year of 1907

The Annual Timing Contest of the

GENEVA ASTRONOMICAL OBSERVATORY

awarded

53 out of 101 Prizes

TO

Patek, Philippe & Co. WATCHES

Namely:—The only First Prize for best Average Running among Makers. 4 First Prizes out of 5 (Including all the highest) for best individual running.

10 Second Prizes	out of 18
9 Third " "	" 17
12 Fourth " "	" 26
7 Honorable Mentions	" 18
10 Single Prizes	" 17

19 MANUFACTURERS PARTICIPATED.

Previous results at these contests

1906—49	out of 85 Prizes, incl. the First and Highest Prizes
1905—46	" 65 " " " "
1904—36	" 46 " " " "
1903—42	" 54 " " " "
1902—32	" 56 " " " "
1901—28	" 49 " " " "

Awarded Hors Concours (Beyond Competition)

Milan, 1906. St. Louis, 1904. Paris, 1900. Paris, 1889.
Antwerp, 1885. Zurich, 1883.

Gold Medal

Nuremburg, 1905. London, 1885. Calcutta, 1883.
Croningen, 1880. Paris, 1878. Vienna, 1873. Paris, 1867.
Paris, 1855. London, 1851. Paris, 1844.

Diploma of Honor: Nice, 1883.

NEW YORK
68 Nassau Street

GENEVA,
SWITZERLAND

Practical Course in Adjusting

By THEO. GRIBI

Comprising

A review of the laws governing the motion of the balance and balance spring in watches and chronometers, and application of the principles deduced therefrom in the correction of variations of rate arising from want of isochronism, change of position and variation of temperature.

Elucidated and Demonstrated

By original experimental researches in the actual problem, never before published, showing the causes that are operative in the variation of rate, and leading to correct remedies. To which have been added chapters on

How to make a Balance Arbor with Modern Appliances; How to Clean a Watch Properly; and, the Lever Escapement—Some Current Defects in it and How to Remedy Them.

Published Price, \$2.50.

**SPECIAL REDUCED
PRICE, \$1.50,**

Post prepaid.

250 pages, including 18 diagram plates; Fine Paper; Large Type; Clear Illustrations; Systematically arranged; Solid Binding. :: ::

**THE JEWELERS'
CIRCULAR PUB. CO.**

Publishers

11 John St., cor. Broadway
NEW YORK

A Page from Watch History

The picture at the left shows the old Roman tower in which the Vacheron & Constantin watch factory was located in the early days of watch history.

The picture at the right shows the present factory, built in 1875, and remodeled some years ago.

These illustrations not only mark the progress of the V. & C. watch, but of the entire watch-making industry, for the Vacheron & Constantin was recognized as the standard of excellence when the watch was first placed on the market in 1785, and is so recognized to-day.

It has always led in correct, scientific principles, in absolute accuracy, and in all the various improvements in watch manufacture since the establishment of the house. It has captured many first prizes in international timing contests, and its unquestionable superiority renders it the most salable and profitable high grade watch that the dealer can offer his customers.

The V. & C. line embraces every variety of adjusted watches, complicated watches, extra flat, ultra flat, and enameled, carved and jeweled watches.



EDMOND E. ROBERT, Sole Agent, 3 Maiden Lane, New York

The Favorite Movement

WITH BOTH TRADE AND PUBLIC

The Omega movement stands in high favor with the trade, and is constantly increasing in popularity for the reason that the public is quick to appreciate its merits.

The man who carries an Omega is proud of it and misses no opportunity to sound its praises to his friends. He finds it invariably and uniformly reliable. He learns to depend upon it and it never abuses his confidence.

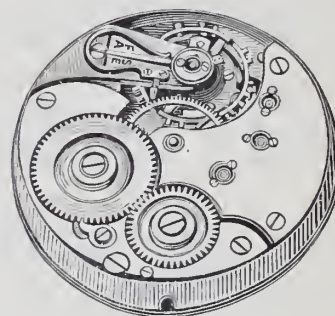

Ω
OMEGA

Adaptable, Interchangeable, and Suited to all Requirements

The Omega is made in all sizes to fit regular American cases, besides a number of Swiss sizes. Every part is interchangeable, and all are made with lever escapements, double roller and pendant set. There are six different grades—from seven jewels to twenty-one jewels—adjusted to heat, cold, and five positions.

EDMOND E. ROBERT
3 Maiden Lane New York

WESTERN SELLING AGENCY
Omega Watches
Heyworth Building, Chicago

CROSS & BEGUELIN
31 Maiden Lane New York



The above TRADE MARK is well known to you, because it is on every watch and watch movement made by the LANGENDORF WATCH CO.

The more of our large line you carry in stock, the more profitable and satisfactory are

YOUR SALES

Perfect Interchangeability of parts renders repairing easy.

Do not accept substitutes, but insist upon getting the genuine L. W. Co. make. It's far the cheapest after all, as the quality is such you may

DEPEND UPON

If your jobber cannot supply you with

THE RIGHT KIND of GOODS

write to the Sole Agents for the United States,

AMERICAN-SWISS WATCH CO.

1 Maiden Lane, New York
CUSHMAN BUILDING



C. L. Guinand Split Chronographs with Minute Registers

The Turfman's Standard.

Remarkable for accuracy and reliability. Are cased in Gun Metal, Silver filled and Gold. Prices reasonable.

Imported exclusively by

Jules Racine & Co.,

Importers of all grades of
Watches and Movements.

103 State Street, Chicago. 37 Maiden Lane, New York.

AUDEMARS, PIGUET & CO.,

BRASSUS and GENEVA.

Manufacturers of Superior

Plain and Complicated Watches.

Represented by

A. WITTNAUER CO.,

9-11-13 Maiden Lane, NEW YORK.

NEW ENGLAND WATCH REPAIRING FOR THE TRADE

GEO. W. HYDE & CO., 101 Tremont Street, Boston, Mass.

Make a Specialty
of Repairing

NEW ENGLAND WATCHES

Work returned in one week, and guaranteed to be satisfactory in every respect
Recommended by The New England Watch Co.

HERMANN GRABEMANN

Reliable Watch Repairing

My work you can call your own

Trade References furnished A trial solicited

81 NASSAU ST., NEW YORK

HOROLOGICAL DEPARTMENT

BRADLEY POLYTECHNIC INSTITUTE

Formerly Parsons Horological Institute

PEORIA, ILLINOIS

LARGEST AND BEST WATCH SCHOOL IN AMERICA

We teach Watch Work, Jewelry, Engraving,
Clock Work, Optics. Tuition reasonable. Board
and rooms near school at moderate rates.
Send for Catalog of Information

THE OIL

NEVER GOES WRONG



The trade from ocean to ocean is praising this wonderful oil. IT POSITIVELY WILL NOT GUM.

Can you say as

much for the oil you are using? Send 25c. to your jobber for a bottle, and end your oil troubles.

RANLETT & LOWELL CO.

SOLE MANUFACTURERS

Jewelers' Building BOSTON, MASS.

Wholesale Selling Agents

- M. SICKLES & SONS Philadelphia
- SWARTCHILD & CO. Chicago
- NORDMAN BROTHERS CO., San Francisco
- D. C. PERCIVAL & CO., Boston
- CHAS. MAY & SON Boston
- DANIEL PRATT'S SON 53 Franklin Street, Boston
- SUSSFELD, LORSCH & CO., New York City
- H. S. MEISKEY CO. Lancaster, Pa.

Rockford Watches Speak for Themselves

Ball Watches

THE RAILROAD STANDARD

Mr. Retailer!

Every Time You
Sell a "Ball" Watch.

1. You earn a fair return on your time and capital invested.
2. You secure a satisfied customer (the best advertisement of all).
3. A machine goes into service which will add to your reputation as a reliable "watch man."

Write to-day THE WEBB C. BALL WATCH CO.

Ball Building, CLEVELAND Railway Exchange, CHICAGO



HALL CLOCKS

Elliott's
Celebrated
Tubular
Chimes

HARRIS &
HARRINGTON,

12 BARCLAY ST.,
NEW YORK

Sole Agents to the Trade
for
J. J. ELLIOTT & CO.
LONDON.

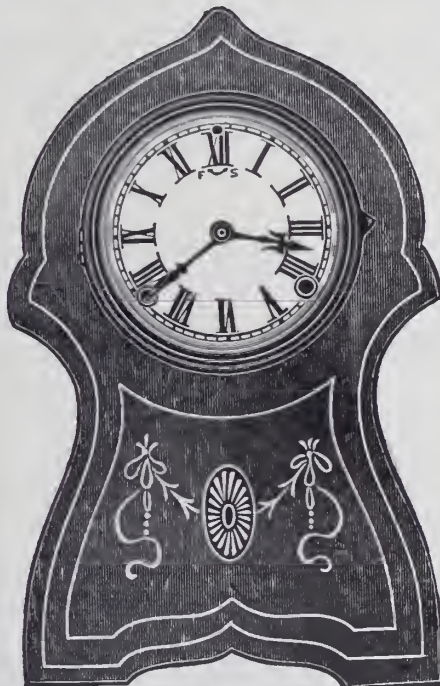

MANCHESTER

Height 13¾ in. Width 8¾ in.

SESSIONS CLOCKS

Superior Finish
Popular Prices

We have added a number
of fine marqueterie cabinet
clocks to our line which will
interest you.

The Sessions Clock
Company

FORESTVILLE, CONN., U. S. A.

New York Salesroom, 37 Maiden Lane

ESTABLISHED 1887

DUBOIS WATCH CASE CO.

Manufacturers of

Fine Solid Gold Watch Cases

Specialties in Casing of

CHRONOGRAPHS, REPEATERS AND ALL KINDS OF COMPLICATED WATCHES

NEW YORK OFFICE:
21-23 Maiden Lane

FACTORY AND MAIN OFFICE:
316 Herkimer St., Brooklyn, N. Y.



The Jeweler's stock that does not contain
a full line of

New England Watches

is far from being complete, and that Jeweler
is in line to lose a large number of sales.

The New England Watch Co.
WATERBURY, CONN.

Chicago

San Francisco

Buy Watches With Our Patent Ball-Bearing Bow

Already on the Market

No watch case should be without it.

BEWARE OF IMITATION



Should your jobber not sell cases with these bows, write us and we will
give you a list of jobbers who do.
Patented July 25, 1905; May 21, 1907. Other patents applied for.
Patented in foreign countries.

The Wachter Manufacturing Co.
HARTFORD, CONNECTICUT

JULES JÜRGENSEN
Watches and Chronometers
PARIS—"THE GRAND PRIX"—1900

SOLE
RUDOLPH & SNEDEKER
65 Nassau St., New York
AGENTS

WATCH REPAIRING
FOR THE TRADE
Careful, Reliable, Prompt Work. Trade Refer-
ences. Price List on Request.
A. D. PAPAZIEN
71-73 Nassau St., Cockroft Bldg. **NEW YORK**

REMOVAL

FROM

PHILADELPHIA to NEW YORK

No. 35 MAIDEN LANE

Wm. C. Penfold Co.

Largest Exclusive Watch Jobbers in New York

OF

Dueber-Hampden Watches Dueber Cases—Hampden Movements

A COMPLETE LINE ALWAYS ON HAND

Mail Us Your Orders

TIFFANY ELECTRIC CLOCKS

NO SPRINGS

NO WEIGHTS

NO CLEANING

NO OILING

350 JEWELERS—ATTENTION 350

In New York, Pennsylvania, Ohio, Indiana, Illinois, Iowa and Michigan we have given, in over thirty cities in each State, the exclusive sale of our Mantel Clocks to leading Jewelers in their respective cities. We also have such an arrangement with Jewelers in every State in the Union. As we sell *direct to the Jewelers*, there are *no cut prices*.

It pays 350 Jewelers to deal with us in this way and is worthy of your consideration. For prices and other information, write



STYLE No. 1

Also Other Styles

TIFFANY ELECTRIC MANUFACTURING CO.

Manufacturers of Tiffany Electric Clocks

General Offices and Factory, 437-453 ELEVENTH AVENUE, 36th to 37th Sts., NEW YORK, N. Y., U. S. A.

STORE KEEPING DEPARTMENT

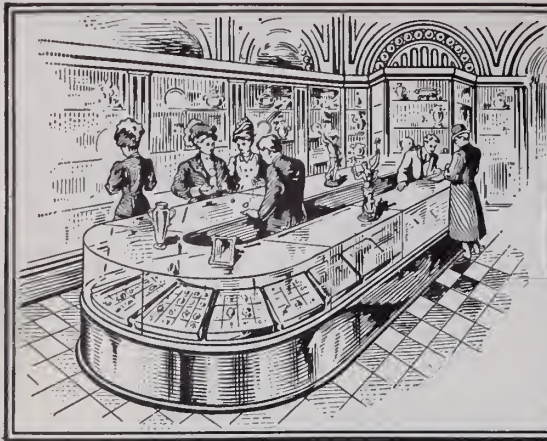

That this department shall prove mutually beneficial to our readers, it is desirable that the members of the trade generally communicate with THE JEWELERS' CIRCULAR-WEEKLY regarding any advantageous device or plan which they are utilizing in connection with their business.

Original Displays Made by Enterprising Jewelers

Including a Wind-mill Illuminated by Electric Lights

An Easter Show Window.

HERE is an attractive looking display which was made by the Gilreath-Durham Co., Greenville, S. C.:

This window has a fixed mirror back and reaches up to a height of about 18

inches. The background above is plain window glass, over which, when the photograph was made, was draped a pair of lace curtains, and between these, just back of the window, a large palm was placed.

The floor was white, and in the center at

the back was a mound, on either side of which was an Easter lily, while jewelry suitable for Easter wear was distributed over the floor and mound, with here and there a few pieces of cut glass and table mirrors.

A Wind-mill Advertising Diamonds.

What is perhaps one of the most attractive outdoor advertising features ever attempted by a Pittsburg jewelry house, is the Dutch Wind-mill erected at Sixth Ave. and Grant St., by Gillespie Bros. of that city. The mill is located on a plot of ground in the shadow of the big Frick building, the lot having been made vacant because of the razing of an old land mark, which was demolished to make room for the widening of Webster Ave.

The mill is brilliantly lighted with electric lights and has attracted the attention of thousands, because of its location, all street cars from the East End to the downtown district passing this point.

The accompanying photograph presents an excellent likeness of the mill and its well-lighted arms at night present a picture which is hard to surpass for beauty. Gillespie Bros. use the daily papers extensively as well as sign board advertising.

Words of Counsel for Salesmen.

MEN WHO SELL THINGS.—Observations and experiences of over 20 years as traveling salesman, European buyer, sales manager and employer. By WALTER D. MOODY. 295 pages, 16 mo., bound in cloth. Published by A. C. McClurg & Co., Chicago. Price, \$1.00 net.

IN this book, as the author states in the opening chapter, an effort is made to state the qualifications essential to the making of a successful salesman. The work is written by an expert in the art of salesmanship who undoubtedly has no small insight into human nature as well as the different genera of salesmen and alleged salesmen.

Reasons are given for the success and non-success of certain members of the craft, and the thoughtful reader can form many conclusions which will prove beneficial to him.

Some idea of the scope of the book can be gleaned from the different chapters, which are as follows: "Pure Grit," "The Knocker," "The Order Taker," "The Fussy or Over-Anxious Salesman," "The Wheelbarrow Salesman," "The Know-it-all Salesman," "The Quick-Tempered Salesman," "The Sky-Rocket Salesman," "The All-Head-and-No-Soul Salesman," "The Old



AN EASTER WINDOW DISPLAY, BY THE GILREATH-DURHAM CO., GREENVILLE, S. C.

Storekeeping Department.

imer," "The Right Kind of Salesman," "The Mind as a Magnet," "Specializing Efforts," "Letters to the Trade," "Getting the Price," "Dress and Orderliness," "Retail Salesmen," "The Salesman's Relation to the Buyer," "The Sales Manager," "Getting an Interest in the Business."

Each chapter is preceded by a terse, rather epigrammatic suggestion of what is to follow. The style of writing adopted is pleasing and well spiced here and there with bits of genuine humor.

Present Opportunity.

JUST now, when some firms are content to sit down and take what business comes to them, is the time when the really progressive firm ought to start out to capture the trade by the right kind of advertising.

Now is the time to make new customers, and to take advantage of this inactivity on the part of the timid, who have dropped out of the contest for the time being.

To firms which will wage a vigorous campaign of advertising, intelligently directed, the present time offers the opportunity of a lifetime, because competition in the advertising field will be slightly less keen—but at the same time the field will be practically as large as ever before.—St. Joseph, Mo., *Fruit Grower*.

The conscientious trade paper is indispensable at all times, but its power is most manifest in periods of unsettled business conditions.

A Representative Retail Jewelry Store of Atlanta, Ga.

ILLUSTRATED herewith is an interior view of the store of W. J. Timms, Atlanta, Ga. The store room proper is 55

of steel, with a border also of steel and extending down three feet, connecting with the burlap, which covers the walls down to the marble base. The fixtures are all mahogany.

The front is entirely of plate glass. All-



AN INTERIOR VIEW OF THE STORE OF W. J. TIMMS, ATLANTA, GA.

feet long, 20 feet wide and 16 feet high. The floor is of Mosaic tiling and the ceiling

the wood work is of mahogany. At the base of the show windows in the front of the store are two feet of Italian marble, the front being entirely of glass. The lighting facilities of the establishment are exceptionally good.

The store is illuminated by means of three large arc lights. In each wall case are 10 incandescent lights of 16 candle power each. Two watchmakers occupy the front part of the store. A room in the rear, 20 by 20 feet, is devoted to the watch material department.

Above the store is the engraving and repairing department. This store was completed last August at a cost of \$10,000. The business has prospered from the start and the working force now consists of three watchmakers, two engravers, one jeweler and repairer.

Truth.

SHOP windows are a sort of mechanical education. A stranger let loose among London's miles of windows will know half of them intimately after he has walked the streets a month or two; nor need he devote any time to become acquainted with them, for they have a trick of devoting time to him.—*Profit Maker*.

Better that the cleanliness of your store go unnoticed than that anyone have occasion to remark upon the presence of dirt.

The same old show case arrangement month in and month out, no matter how many new goods, looks like the same old stock. Change things around if you want to attract attention.—*Printer's Ink*.



AN INGENIOUS NOVELTY IN OUT-DOOR ADVERTISING, BY GILLESPIE BROS., PITTSBURG, PA.



Above Cut Shows Our

METAL SPINNING LATHE

We manufacture these lathes in sizes from 12-inch to 44-inch Swing, and can equip sizes 18-inch and larger with our Chucks for oval work.

Write for Catalogue **P. PRYIBIL, 512-524 W. 41st St., New York.**



A Small Compound Sand Blast

Price, \$20.00 Foot Bellows, \$6.00

WORKS AS EFFECTIVELY WITH FOOT BELLOWS AS WITH POWER BLOWER :::::

MADE of Galvanized Sheet Iron, 10 inches diameter, Glass Top, Fittings of Brass and Iron, practically indestructible. Satisfaction guaranteed. Ask your Jobber for it, or write to us. Other Specialties: Zeuner's Best Jewelers' Saws; American Swiss Files, equal to the best imported; Gas Furnaces, for Melting, Annealing, etc., etc.; Positive Pressure Blowers.

E. P. REICHEL & CO.
JEWELERS TOOLS, FILES AND SUPPLIES
24 JOHN STREET, NEW YORK

1 2 3 4 5 6 7 8 9 0 1 9 0 8 A B C D E F G H I J K

Alphabet and Figures

FOR CLASS RINGS, EMBLEMS, ETC..

HERPERS BROTHERS,

SETTING MANUFACTURERS,
Newark, N. J.,

1 9 0 8

1 9 0 8 A B C D E F G H ETC. 1 9 0 8

BUY CUTTLE FISH BONE

The mark P-E-A-CO. insures quality. Secure our prices before buying elsewhere; it will pay you.

P. E. ANDERSON & COMPANY

IMPORTERS 7 @ 13 GOLD ST., NEW YORK CITY

Importer and Manufacturer of
WATCH MATERIALS, TOOLS, JEWELERS
SUPPLIES AND OPTICAL GOODS

Bargains in Staking Tools



Prices on Application

Fine Gold, Silver and Platinum always on hand. Highest Prices paid for Old Gold and Silver.

A. ZAREMBOWITZ

250 East Houston Street NEW YORK

J. H. GALAWAY P. H.

ENGRAVERS
CRESTS, MONOGRAMS and LETTERING
7 Maiden Lane, Rooms 44-48
Established over 35 years



WORKSHOP NOTES AND QUERIES

[Answers are also solicited from our readers to the questions published on this page.]

QUESTION No. 2079.—To Make Chain Clasps.—How can I make several kinds of chain clasps, to be useful for repair jobs and used when our stock has run out?

T. M. C.

ANSWER:—The *Deutsche Goldschmiede Zeitung* gives an interesting description of



FIG. 1

a mode of making a few very simple chain clasps. They can easily be made by any jeweler or watchmaker. Chain clasps are mostly made from tubing with a thin wall, or the tube may be made by cutting a strip

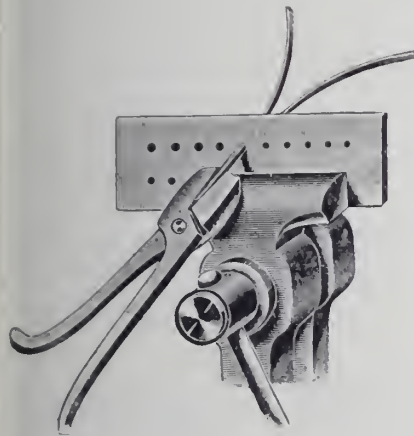

FIG. 2.

of the sheet metal and forming up on the draw plate. (See Fig. 2.) The complete snap is shown in Fig. 1; a is the tube which has a bottom on one end with a hole drilled in the right size; on the opposite end a

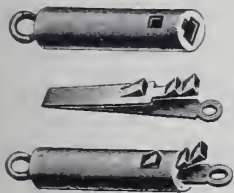

FIG. 3.

ring is soldered in. The spring b (Fig. 1) is made of half-round wire, bent together to form a round to fit the hole in the tube. This spring can, if the jeweler possesses a half-round draw plate, be drawn out of a round wire. If there is no half-round draw

hole, then it can be done on the round draw holes. Roll a round wire flat and solder two ends together. File the soldered ends to a point and draw, as shown in Fig. 2, to the right size. The spring is shaped out of the half-round wire like b, in Fig. 1. A notch is filed in with a three-

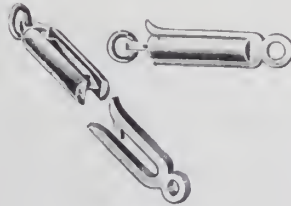

FIG. 4.

cornered file so it will catch in the bottom of the tube a (Fig. 1). The notch should be filed not flat, but a little round, so as to conform to the shape of the hole. This catch is very simple and can be made quickly, but does not produce a very safe catch. A better and more reliable catch is represented in Fig. 3, which is also out of a tube, with a bottom filed out to take in the flat spring as shown in the illustration. In addition the tube has a hole on the side in which is a knob soldered on the spring to snap into it, making a very reliable snap for a chain. Fig. 4 represents a safe and easily made snap, but one objection is found, and that is that it is not very easy to open, and for this reason not much used.

QUESTION No. 2080.—Removing Dents from Watch Cases.—How can we remove dents from watch cases? I refer to small dents that are produced by careless handling in the store.

R. D.

ANSWER:—Dents in watch cases may be removed from most cases without taking the case to pieces. There are various stakes suitable for taking out the dents with a smooth hammer or hard wood mallet. A proper stake is secured in the vise and the dents are raised out by means of the hammer by gently working to bring the parts in conformity with the surface. If the cases are polished care must be exercised to prevent chafing the surface on the stake—that is, by not moving around. Hold in one position. Very often the hammer marks will show, especially if the case is a plain one; then the place must be filed over with a very fine file and polished well again. Engine-turned cases require very careful handling if dented; the engraving is very tender, and will show defects which are difficult to remove.

QUESTION No. 2081.—To Color Jewelry Repairs.—I want something that I can rub

on cheap jewelry that has been repaired. A yellow gold color and a formula for a red gold would be very desirable.

T. C.

ANSWER:—Repaired jewelry can be colored by rubbing on the following with a cork: For a yellow color, suitable for brass, copper or silver, dissolve four grains of fine gold in 35 grains of aqua regia. In this solution immerse small pieces of linen. Enough linen should be used to take up all the solution. Let the linen dry, then put in a sheet iron can and put over a fire so that the rags will be burned into fine ashes. Carefully gather the ashes with the particles of gold. When ready to use, take a cork and wet it with salt water, take up some of the ashes and rub it tightly on the well-cleaned jewelry. This will produce a yellow gold color. For a red color, take the same solution as above and add four grains verdigris, four grains pulverized salammoniac, one grain saltpeter. Dip into this the linen rags. When dry, burn, gather the ashes and proceed just as for yellow gold.

QUESTION No. 2082.—Bright Cutting Aluminum.—Kindly give me a receipt for bright cutting aluminum?

J. R.

ANSWER:—Mineral oils like coal oil or vaseline, are generally employed. A mixture of benzine and vaseline is also used. The materials turpentine, stearine and rum are said to give satisfaction if the mixture is made as follows: Four parts of oil of turpentine, one of stearine and one of rum. Experience, of course, is also necessary in treating this metal, which, notwithstanding the fact that it is a comparatively soft metal, is hard on files and steel tools employed in working it. A graver for aluminum can be sharpened to a more acute angle than if used on coin silver or copper.

QUESTION No. 2083.—Palladium Balance Springs.—Are palladium balance springs still made and used?

J. R. B.

ANSWER:—Palladium balance springs were originally introduced as non-magnetic springs. In their early use it was discovered that palladium balance springs, when applied to marine chronometers, would not accelerate as much as steel springs, and trials also showed that the middle temperature error in the compensation was considerably less with them than with steel springs. It was feared, however, that palladium springs were not as lasting in their elasticity as hardened steel springs, and their use was very limited on this account. It is said that of late an alloy of some metals of the platinum group with iridium, supplied this want of elasticity, and this is largely used with good success.

In a novel electro-plating process recently developed in France, the solution—which may be of any of the usual plating baths—is contained in a brush, which is connected to the positive pole of the electric circuit, while the object to be plated is connected to the negative pole, and simply brushing the well-cleaned object gives a regular and adherent deposit. The thickness of the layer formed depends on the duration of the brushing and the number of applications to each spot. Larger objects than usual can be covered, and a surface may be plated with several different metals, thus giving a varied decoration.—*London Horological Journal*.

C. DORFLINGER & SONS

36 MURRAY STREET

NEW YORK



Hand-Made Blanks only.
Cut, engraved and etched
glass. Light, medium
and heavy stemware,
tumblers, etc.

The Pairpoint Corporation

NEW BEDFORD, MASS.

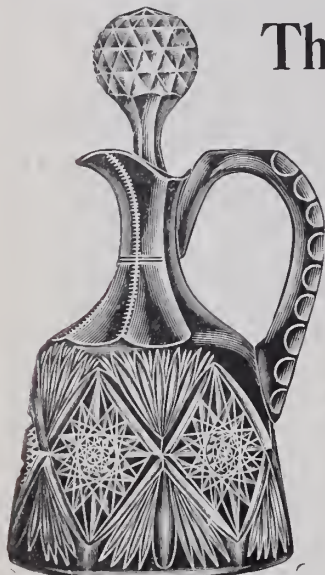

SUPERIOR
SILVER PLATED
WARE

RICH
CUT GLASS
WARE

ELECTROLIERS
GAS PORTABLES, ETC.

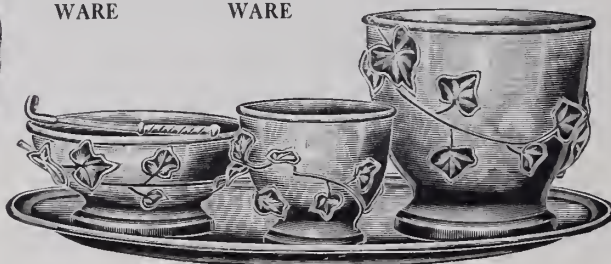

No. 4935.—Smoking Set.

No. 692.
Whiskey Jug.
"Uncatena."

BRANCHES
38 Murray Street - - - - NEW YORK CITY
717 Market Street - SAN FRANCISCO, CAL.
485 St. Catherine Street - MONTREAL, P. O.



35 MAIDEN LANE

Manager
New York Office
for

MIDDLETOWN SILVER CO.

Silver Plated Hollowware

O. F. EGGINTON CO.

Exquisite Cut Glass

CORNING CUT GLASS CO.

Popular Specialties

ROGERS SILVERWARE

Write for Prices

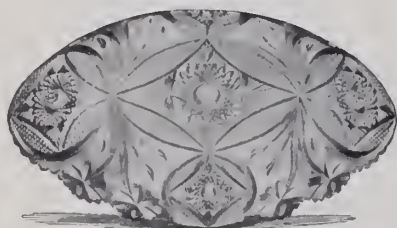

"Wild Rose," No. 122—14-inch
Ice Cream Tray

Irving Cut Glass Co. Inc.

Manufacturers of

Artistic Cut Glass

HONESDALE, PA.

F. W. REICHENBACHER

New York Representative 59 PARK PLACE

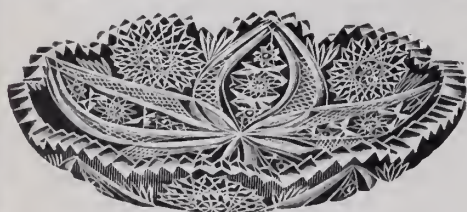

7-in. Saucer, Pansy No. 205

KELLY & STEINMAN, Inc.

Manufacturers of

Rich Cut Glassware

Is Quality any consideration
with you? If so, let us send
you a Sample Order.

OUR PRICES ARE MODERATE

KELLY & STEINMAN, Inc., HONESDALE PENNSYLVANIA

The St. James

Cor. Walnut and 13th Sts., Phila., Pa.

THE IDEAL HOTEL OF
THE QUAKER CITY

A spacious fire and burglar proof
safe has been provided for the con-
venience of the trade. Palatial
rooms with bath \$2.50 per day
and up. Rooms without bath,
(running water) \$2.00 and up.

EUGENE G. MILLER, Mgr.

Established 1879

Manufacturer of

LOUIS W. HRABA Fine Leather Goods

29 East 19th St., New York

Exclusively for the Jewelry Trade

JACOT MUSIC BOX CO

MIRA MUSIC BOXES
AND MIRAPHONES

39 UNION SQUARE - NEW YORK

THE CONNOISSEUR

Devoted to Art Pottery, China, Marbles, Bronzes, Cut and Decorated Glass Ware, Bric-à-Brac, Lamps, Art Metal Wares, Fancy Goods and Kindred Lines.

America's First Glass Factory.

By A. F. Rockwood, in the *Crockery and Glass Journal*.)

THE first American glass factory was erected in the town of Temple, N. H. Washington in his diary speaks of glass being made in New Haven, Conn., in the year 1789. One would suppose by the language he uses that he considers it a new and quite extraordinary affair. It was nine years previous to this, and during the very year whose issue first enabled the country to commence its own manufacturing, that Robert Hewes, of Boston, began to carry out the project which he had long conceived, but had hitherto found impracticable, if not impossible, under English rule—that of making glass in America for America.

In 1780 Mr. Hewes selected a site for his factory secure from the British forces (his glassblowers were Hessians and Waldeckers—soldiers who had deserted from the British army), and he must have had an eye for the beautiful in nature. He chose a spot on the north slope of Kidder Mountain, near its base. To the northwest Mt. Monadnock rears his granite crown, standing like a giant sentinel; to the north, and running east, are the Temple mountains, bold and precipitous; to the east a beautiful valley holds in its embrace the towns of Wilton, Milford and Nashua; while to the northeast Joe English Hill and the Uncanernucks mountains conceal the city of Manchester.

The place is now reached by a two-mile walk over an old road, long a stranger to travel other than by grazing cows and nature-loving tourists. The stone-work about the ovens and the foundations of the building are all that now remain to remind us that here was another example of the American people's struggle for independence; for, says Goodrich's History of the United States, "anterior to the Revolution, the Colonies were not permitted to manufacture even for themselves; the object of England being to keep them in a state of dependence. Even Lord Chatham, the friend of American liberty, said they should not be allowed to manufacture even a hobnail. During the Revolutionary struggle the people were in no condition to turn their thoughts to manufacturing—and, indeed, it is only since the commencement of the present century that the genius of the people has had full scope."

Mr. Hewes seemed to meet with misfortune in his venture almost from the start, as shown by a letter from him to the Selectmen of Temple, asking aid from the town and freedom from taxes for a time,

as his first building was burned. His neighbors helped him to rebuild; but then it was found that the furnaces were spoiled by exposure to the weather, frost having got in, and only a few samples were made.

We find upon examination of the town records that Mr. Hewes received the aid sought. A town meeting was called March 5, 1781, "to advance upon loan to Mr. Hewes £3,000, with good security, to be assessed in two months from this day, and collected as soon as may be." The Book of Acts of the N. H. General Court, 1780-81, contains the following: "In the year of our Lord 1781. An act to authorize certain persons to raise £2,000 of the new emission, to enable one Robert Hewes to carry on the manufacturing of glass in the town of Temple, county of Hillsboro."

The glass house was 65 feet square. The sand was drawn by oxen from Littleton, Mass., coming from Magog Pond, over hilly roads, a distance of 30 miles. The principal manufactures were decanters, bottles and window glass—a few specimens of which are still in existence.

Robert Hewes was an extraordinary man. Everything that relates to him is of interest. It is said of him: "He was very ingenious and industrious, and possessed an excellent education. He taught the use of the Scotch broadsword to the officers of our army, also a company of cavalry in Boston, and composed and published a considerable book on the Art of Defense."

He was born in Boston, and lived on the corner of Essex and Washington Sts. in a fine house with spacious court and magnificent shade trees. He was short, a bit rotund, of light complexion, and very active.

The *Columbian Sentinel* of July 21, 1830, contained this obituary: "In this city, Dr. Robert Hewes, aged 79; long known as a celebrated bone-setter and fencing-master." According to the city register, he died of old age, and was buried in tomb No. 18, Central Burying Ground (on the Common). He is said to have left no children.

Glass Manufacture in Ireland.

AT a recent meeting of the North-East branch of the National Council, held at 87 Marlborough St., Dublin, S. Deakin made some very interesting references to the industries of North-East Dublin, and gave the following account of the glass trade:

The manufacture of fine table glass was carried on from about 1785. Taking up the Dublin Directory for 1801 we find an

entry: "Richard Williams & Co., fine flint glass manufacturers, Potter's Alley (off Marlborough St.)." At this time Irish-made table glass set the standard for quality, practically, to the world, more particularly through the Belfast and Waterford glass, but the two Dublin works are considered of sufficient importance to warrant mention in nearly every contemporary work dealing with Irish manufacture. The only Dublin glass he (Mr. Deakin) had ever seen was made in these same works just before they were finally closed down about 1889, and, although perfectly plain, was very beautiful in quality and luster.

It has not been the case very often that an Irish industry could be said to owe its development to the attention of the English government; yet the prosperity of the Irish flint glass industry must, to a great extent, be placed to their credit. Somewhere about 1780 the English government, being on the lookout for something to tax, bethought them of their flint glass industry, then an important and a flourishing one, and for some reason best known to themselves the duty was levied, not on the resultant product, but upon certain of the raw materials used. This wiped out a considerable number, and forced the remainder to put on the market everything that passed successfully through the annealing furnace—resulting, of course, in lowered quality. Before 1780 not only had England no export trade, but actually imported nearly all its fine glass ware. In about four years' time, although the sand and other raw materials had to be imported, as well as all the clay forming the crucibles—imported, mark you, from England—in spite of this and the higher wages ruling in Ireland, Irish glass was 10 per cent. below the price asked for the English product.

In 1783-4 Ireland exported 20,736 drinking glasses to America, as well as quantities of other glass ware. Commenting on this, a contemporary writer remarks: "This, however, may be considered as an effort on the first opening of trade with America, and it may be doubted whether a speculation of so much risk will speedily be repeated to the same extent." Yet we find a steadily increasing trade with the United States up to the time of the Union. In 1798 the two Dublin factories had sufficient orders in hand from New York alone to keep them working for two years. It is interesting to read that the Irish looked to capturing, in addition to the large trade they were then doing, the entire of England's trade, too, and the possibility of the latter country seriously competing does not seem to have been entertained."—*London Pottery Gazette*.





**Buckles
Clasps
Belt Pins**

Artistic, But Inexpensive

PRODUCTS OF

The "Apollo Studios"

WILL INCREASE YOUR
SPRING SALES



Bernard Rice's Sons

544 BROADWAY

Works and Studios } 4-6 Marion St.
 } 205-207 Lafayette St. **NEW YORK**



No. 471—ELECTROLIER
(Patent applied for)
Copper Bound, Leaded Glass Shade

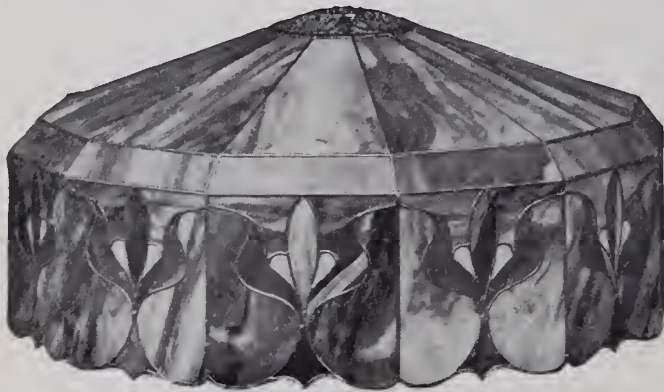

3020 - 18 in. Diameter TOP HANGER

Unique Art Glass & Metal Co.

46 Park Place, NEW YORK

Makers of High Grade

ART GLASS DINING ROOM FIXTURES

Lamp Shades, Electric Shades
and Portables

CALL IN AND SEE OUR BEAUTIFUL LINE
OF PRODUCTS AT POPULAR PRICES :: ::

Also an elegant line of Rich Crystal Cut Glass
at Factory Prices

NOVELTIES ==

FANS

For the Jewelry Trade

A complete stock of un-
usual and exclusive
designs

Louis Steiner

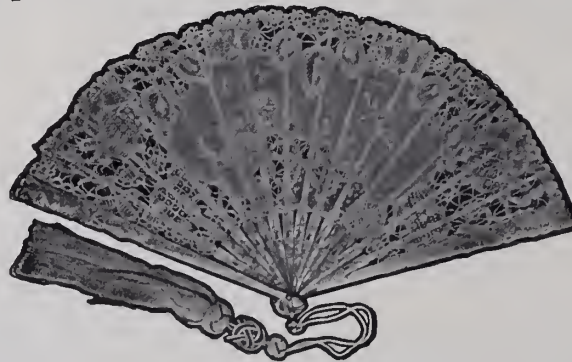

== **NOVELTIES**

FANS

of Every Description

An assortment of Fans
that is unequalled in
this country

520 and 522 BROADWAY
NEW YORK



**LEMAIRE OPERA
GLASSES**

LEMAIRE FIELD GLASSES

Best in the World. Used in the Army and Navy.

SUSSFELD, LORSCH & CO., Importers

37 MAIDEN LANE, NEW YORK

MARQUE DE FABRIQUE



All Genuine Glasses
Bear This Mark
Large Variety in All
the Latest Styles

Alaska-Yukon-Pacific Exposition to Be Held at Seattle, in 1909.

By FRANK L. MERRICK.

NOW that the Jamestown Ter-Centennial Exposition has closed, all eyes are turned toward the next great world's fair, the Alaska-Yukon-Pacific Exposition, which will be held at Seattle, Wash., opening June 1, and closing Oct. 15, 1909.

This exposition will be held in a section of the country where world's fairs are new, and for that and many other reasons it is expected to be a success, beneficially, educationally, artistically and financially.

Work on the grounds and buildings of the exposition is well under way and the management is determined to have everything in readiness by opening day. This has been written about all expositions in late years but the promise has never been completely fulfilled. The officials of the Alaska-Yukon-Pacific Exposition, however, have started out with a completed-on-opening-day idea above everything else, and if they do not carry out their plan it will not be because western energy has not been expended in the task.

The Alaska-Yukon-Pacific Exposition promises to be different from former world's fairs in many ways, but one policy stands out so far above any of the rest that the entire press of the country is commenting favorably about it. No money will be asked from Uncle Sam to carry on the work! That policy must be conceded as original. All the management desires is for the United States government to participate in the same manner as foreign countries and the different States, by erect-

Manufacturers' building, Agriculture building, Auditorium, Palace of Fine Arts and Machinery Hall. The three latter buildings will be permanent structures, built of buff brick with terra cotta trimmings.

The "A-Y-P," as it is sometimes called in Seattle, will differ again from some former fairs in that some of its exhibit palaces will be permanent structures. The grounds are located on the property of the Washington University, a State institution, and after the exposition is over, the permanent buildings and those substantially built will be taken over by the college to be used for educational purposes.

The management of the Exposition has secured the services of Col. Henry E. Doseh, of Portland, Ore., as director of the division of exhibits. The exhibits department is being organized and prospective exhibitors can now receive information in regard to space by applying directly to Col. Doseh.

The Manufacturers' building is well under way and will be the first large exhibit palace finished. It will be about 445 by 145 feet in size and will cost \$80,000. Including the galleries, the Manufacturers' building will contain about 80,000 square feet of floor space.

Presentation Sword Designed and Supplied by a Brooklyn Jeweler.

THE accompanying illustration shows a presentation sword designed and supplied by I. Bergstein, 143 Sands St., Brooklyn, N. Y., for the engineers' force of the United States gunboat *Paducah*, and presented by them to Max Vogt, Dec. 23, 1907.

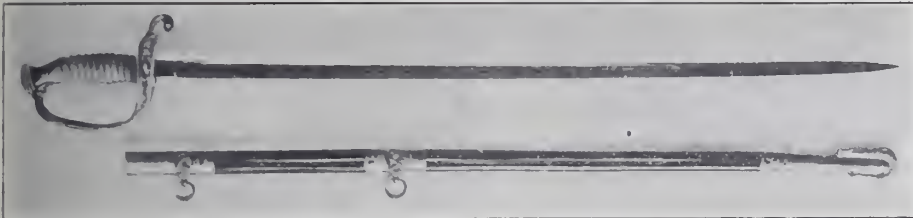

HANDSOME SWORD RECENTLY PRESENTED TO MAX VOGT BY THE ENGINEERS' FORCE OF THE UNITED STATES GUNBOAT *Paducah*.

ing buildings and installing exhibits therein. Since the United States government began to patronize expositions down to the Jamestown fair, Congress has appropriated a total of \$28,752,251 for World's Fairs. Only \$485,000 of this money has been spent west of the Rocky Mountains, the Lewis and Clark Exposition, one of the most successful ever held, receiving the benefit of that amount.

On June 1, last, before a crowd of 15,000 persons, ground breaking ceremonies were held, with many prominent men making addresses. From that date to the present time, work has been going on rapidly upon the exposition grounds. Most of the grading and clearing has been finished. All of the principal roadways, avenues, circles and plazas have been completed. The Administration building has been erected and occupied by the executive force for several months. Contracts have been let for the construction of five large buildings and several small ones. Among these are the

The sword is a fine example of the sword-maker's art of the present day and is gold plated. It is three feet in length and the blade bears the following inscription: "Presented to Max Vogt by the engineers' force of the U. S. S. *Paducah*, Dec. 23, 1907." The same inscription appears on the scabbard near the hilt.

On the handle of the sword is an eagle in relief work surrounded by a circlet of 13 stars.

The Wyoming Cutlery Co., Wilkes Barre, Pa., has elected H. H. Harvey, president; W. S. McLean, vice-president; R. R. Harvey, secretary, and Abram Nesbitt, treasurer. The officers and W. S. Biddle, George Lazarus, A. G. Nesbitt and C. E. Stegmaier are the directors.

According to consular notes received from India, the amount of jade mined in that country during 1906-7 was 2,214½ hundredweight, which was valued at \$39,309.

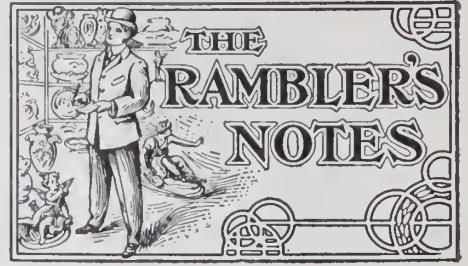

"ALASKAN FISHERMEN" is the title given an attractive

ARTISTIC BRONZES

bronze group by Louis Potter, seen at the Fifth Ave., New York, salesrooms of the Gorham Co. The production represents two fishermen in the act of drawing in a net in which are several fish. One of the men holds the net while his companion has just speared one of the fish in the net and is about to remove it to safety. Another attractive subject, "The Time of Nero," shows four spirited horses held in curb by a stalwart man, who stands upright in a chariot. The chariot is embellished with raised work. The group is mounted on an oblong base.

*

NOVELTIES IN ELECTROLIERS

AT the salesrooms of Bawo & Dotter, 30 Barclay St., New York, are to be seen some attractive lines of electroliers, among which is one representing a chubby child standing, while on his shoulder he holds a flower pot containing flowers, which partly conceal small clouded electric light bulbs. Another offering is a mirror within a bronze frame. At one side of the frame is an electric light bulb. On the opposite side a part of the frame of the mirror is formed by a representation of a woman, who in one hand holds a torch, which ends in a clouded electric light bulb.

*

LIMOGES CHINA NOVELTIES.

THE assortment of Limoges china at the warerooms of Vogt & Dose, 43 Barclay St., New York, includes attractive offerings that should appeal to the jewelry trade. There is a dainty china tea set composed of a small teapot, and sugar and cream holders, all finished in gold effect and with fruit and leaf patterns in the decorative scheme. Small bon-bon baskets, dainty trays and similar novelties are also included in the display. Among other offerings is a tobacco jar cleverly decorated, which has on the cover a pipe modeled in the china. THE RAMBLER.

George E. and O. B. Daniel have purchased the business of E. M. Cook & Co., Marietta, Ga. The new firm style will be Daniel Bros.

The Hay Bros. Jewelry Co., St. Joseph, Mo., have filed a warranty deed at the local court house conveying to George Levy 35 feet of a lot at 707 Felix St. The consideration named in the deed was \$20,000. The property was purchased by Hay Bros. from the present huyer about two years ago.



**"A
Midsummer
Night's
Dream"**

is the latest production of the *Royal Doulton* factories. Exquisitely enameled in rich colors.

=====
Sole Agent

W. S. Pitcairn

*44 Murray Street
New York*



Write for Booklet, "Quaint Bits of Royal Doulton"

**Gems and
Precious Stones**

THEIR

Characteristics, Localities of Production, Tests and Some Current Literature.

A new book on a new plan. Tabulated, concise, authoritative.

A handy manual for every Jeweler.

CONTENTS

CHARACTERISTICS and LOCALITIES of PRECIOUS STONES

Shows in tabulated form the Chemical Composition, Crystallography, Common Fracture, Lustre, Hardness, Color, etc.

TESTS FOR PRECIOUS STONES:

Describes testing implements, methods of testing, mineralogical characteristics, specific gravity, dichroism, tests, etc.

FAMOUS DIAMONDS OF THE WORLD.

SOME FAMOUS DIAMONDS. BIRTH STONES OF VARIOUS NATIONS.

GEMS FOR THE DAYS OF THE WEEK.

POETRY OF GEMS.

BIRTH STONES AND THEIR SIGNIFICANCE.

SIGNIFICANCE OF SOME GEMS.

BIRTHDAY FLOWERS.

ZODIACAL SIGNS OF FLOWERS.

WEDDING ANNIVERSARIES.

FLOWERS OF THE MONTH.

OFFICIAL FLOWERS OF THE UNITED STATES.

CLOTH, POSTPAID, \$1 00

PUBLISHED BY

**The Jewelers' Circular
Publishing Co.**

11 John Street New York

LEATHER WATCH BRACELETS



Send for assortment on Display Card

ESTABLISHED
1850

C. F. RUMPP & SONS

TRADE MARK

*Manufacturers of FANCY LEATHER WARE
PHILADELPHIA*

New York Salesrooms, 683 and 685 Broadway

JANITSCHKE COMPANY, Inc.

33 UNION SQUARE, NEW YORK CITY

Manufacturers of
Patented

DIES

for the Silver and Metal
Trade

ARTISTIC CASTINGS OF EVERY DESCRIPTION
FOR THE SILVER AND JEWELRY TRADE

Iron Hubs and Bronze Forces, False Core Work and Undercut Castings with Elastic Patterns. Fine Plaster Castings by the *Janitschek Patent* Superior to the Asbestos Process

TELEPHONE, 400 STUYVESANT

ROUCH & FITZGERALD



Jewelry Trunks and Cases

177 Broadway,
Bet. Cortlandt
and Dey Sta.
688 Broadway,
723 6th Ave.,
New York.

Don't Worry About the Scarcity of Money

If you need any send us your surplus stock of Diamonds, Watches, Jewelry, Old Gold and Silver, and get our certified check by return mail. If amount is not satisfactory goods will be returned in same condition as received. Strictly confidential. Correspond or call. Telephone, 5202 John.

New York Jewelry Purchasing Co.
106 Fulton Street, New York

Practical Course in Adjusting

Published Price, \$2.50
Special Reduced Price, \$1.50, Postpaid

All Jobbers, or
Jewelers' Circular Publishing Co.

PATENTS

obtained on inventions and designs. Trade-marks, prints and labels registered.

R. W. BISHOP,
ATTORNEY-AT-LAW,

108 C Street N.W., Washington, D.C.

THOSE NEW SHOW CASES

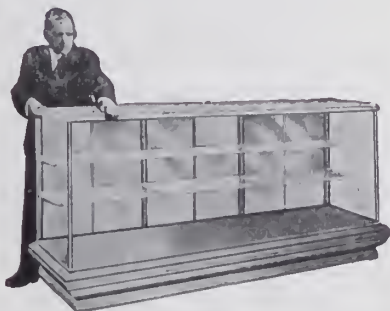

No. 60

In making your decision, bear in mind that the best is cheapest, and that

"Quick Sales" **SHOW CASES**

are the world's best. Comparison, point by point, proves it. There's a reason. We don't skimp at any

point. We put highest quality materials and finest workmanship into our cases. Our designs are standardized. Our prices right. It will profit you to investigate "Quick

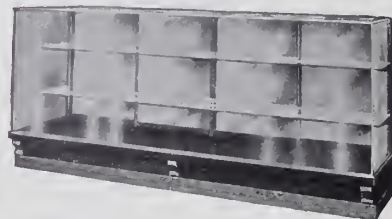

No. 48 All-Glass Frameless Case

Sales" cases — profit you more to buy them. Every good style for indoor and outdoor use listed in our catalog. Write for a copy to-day.

P. S.—We carry in stock a full line of store stools ready for shipment. You will find our prices lowest. Write us.

DETROIT SHOW CASE CO.

DEPT. K

"Show Case Makers to Progressive Merchants"

476-490 West Fort Street

DETROIT, MICH.

ESTABLISHED 1879



S. BORGZINNER CO.

MANUFACTURERS and IMPORTERS

**82 and 84 Nassau St.
NEW YORK**

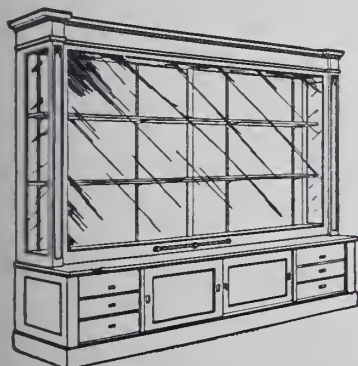

Jewelry Store Fixtures and Show Cases

OUR SPECIALTY

The enlargement of our factory in our new location enables us to quote low prices.

If you need fixtures or show cases let us hear from you. Estimates cheerfully furnished.

ALEXANDER H. REVELL & COMPANY, Rees, Dayton, Eastman and Hawthorne Sts., **CHICAGO, ILL.**

The Ackley Engraving Block

AND "JOKER" ATTACHMENT



Pat. March 20, 1906

Made by Engravers who saw the need of a Handy Time Saving Block

THE BEST IS THE CHEAPEST



Why the "LAFAYETTE MAINSPRING" is superior

1st—It is guaranteed to be made of the Best Steel. 2d—It is made by Skilled Hand Labor. 3d—Each Spring is wrapped in Oil Paper and Silver Foil, which packing positively avoids exposure to the moisture of the air, and therefore all danger of rust is prevented. 4th—Each Spring bears a metal Tag, indicating the watch it is intended for, which accuracy is warranted. 5th—Each dozen is put up in a neat Box, having twelve partitions, one for each spring, so the handling of several springs at one time is avoided. 6th—The finish of the "Lafayette Spring" is, like its quality, superior to any in the market.

THE ACKLEY ENGRAVING BLOCK: Always ready to hold any article. No hunting for pins. The patent friction pins all remain in the head. Simply pull up to the desired height the ones needed. Each pin is numbered on top to designate size of groove or notch in it. They are so arranged in the head that they will readily hold all large or small articles either by three or more points of contact. The swivel jaw can be locked rigidly in an instant. The key will not fall off, yet it may be removed instantly. The patent base eliminates all unnecessary weight and gives the same movement as the old ball and socket base. This block is the result of years of practical experience of engravers who know the wants of engravers. There is nothing complicated about it to wear out or get out of order. Workmanship and materials are the best. Each part is copper plated before being heavily nickel plated, thus insuring a fine durable finish. Height, 6 3/8 inches. Diameter of head, 2 5/8 inches. Diameter of base, 6 inches. Weight, 8 pounds. **THE "JOKER" ATTACHMENT,** as shown beside the block, holds large and small signet and band rings, cuff buttons, collar buttons, signet pins, etc., firmly, without marring. It may be used on any block.

HENRY ZIMMERN & CO., Inc., 77 John Street
New York City

Exclusive Wholesale Distributors for U. S. and Canada

JOHN AUSTIN & SON

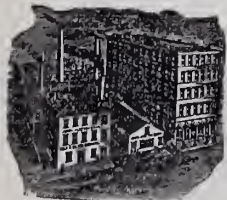

Assayers, Refiners and Smelters

74 & 76 Clifford Street PROVIDENCE, R. I.

We Do Our Own Smelting.

L. LELONG & BRO.

Gold and Silver Refiners, Assayers and Sweep Smelters

S. W. Cor. Halsey and Marshall Sts., NEWARK, N. J.

Prompt attention given to Gold and Silver Bullion.

SMELTING FOR THE TRADE.



(Pat. applied for.)

Balance Hole Jewels. Size of the hole numbered on setting. Saves time and duplication. You can order just what you want. If your jobber does not handle them, send to us. Made for all kinds of American movements.

Ruby and Sapphire, \$1.25 per dozen

THOS. J. JUZEK & CO., Elgin, Ill.

HERMAN KOHLBUSCH, Sr.,

ESTABLISHED 1859.

Manufacturer of Fine Balances and Weights for every purpose where accuracy is required.

Office and Salesroom, 194 BROADWAY, NEW YORK.

Send for Price List.

Tel. 370 Cortlandt.



CRUCIBLES.

Jewelers' Supplies, Etc.

Established 1850.

J. & H. BERGE,

96 John Street, NEW YORK.



PLATINUM AMERICAN PLATINUM WORKS

NEW YORK OFFICE
41 Cortlandt Street

NEWARK, N. J.

LEES & SANDERS,

CHEAP OCEAN RATES
MAKE IT EASY TO COMPETE

SWEEP SMELTERS, BIRMINGHAM, ENG.

'Phone 3759-R.

WM. F. RENZIEHAUSEN CO.

43-47 Oliver Street, NEWARK, N. J.

Gold and Silver Refiners

PROMPT RETURNS MADE FOR ANY MATERIAL CONTAINING PRECIOUS METALS
DEALERS IN GOLD AND SILVER, AND ROLLERS OF STERLING SILVER

Gold and Silver Anodes a Specialty



WE BUY

Old Gold and Silver Filings, Polishings, Sweeps, Hand Washings, etc. We will make accurate valuations and hold consignment subject to your acceptance. If valuation is not satisfactory, we reship to you at our expense.

WE PAY FOR OLD GOLD:

22 K. 88c. per dwt.	12 K. 48c. per dwt.
20 K. 80c. " " "	10 K. 40c. " " "
18 K. 72c. " " "	8 K. 32c. " " "
16 K. 64c. " " "	6 K. 24c. " " "
14 K. 56c. " " "	4 K. 16c. " " "

MARKET RATES FOR SILVER AND PLATINUM

Try us and you will Appreciate our Squareness, Promptness and Accuracy.

T. B. HAGSTOZ, Ltd., Main Office, 709 Sansom St., Philadelphia, Pa.
SMELTERS, ASSAYERS, REFINERS.

WE SELL

Gold, Silver and Platinum, various qualities, rolled flat or drawn to wire of any gage.

PRICES OF ALLOYED GOLD:

8 K. 42c. per dwt.	14 K. 66c. per dwt.
10 K. 50c. " " "	16 K. 74c. " " "
12 K. 58c. " " "	18 K. 82c. " " "

Gold and Silver Solder, either from formulas furnished, or our own. "T. B. H." Alloy, 25c. per oz. Guinea Gold, 75c. per lb. Shot Copper, 40c. per lb. We will send tables for alloying without charge. They save figuring.

UNITED STATES SMELTING AND REFINING WORKS

L. & M. WOLLSTEIN

16 JOHN STREET, NEW YORK

SWEEP SMELTERS AND ASSAYERS

Dealers in Gold and Silver Assay Office Bars. HIGHEST and MOST PROMPT RETURNS made for Sweeps and all kinds of Waste containing precious Metals.

HIGHEST PRICES PAID FOR OLD GOLD AND SILVER

Manufacturers of STERLING SILVER.

Importers of PLATINUM.

Ore and Bullion Assays a Specialty.

CASTINGS Gold, Silver, Bronze, Brass, German Silver, Copper and Iron.
L.D. TEL. 2072 L. Supply Jewelers, Silversmiths, Die-makers, Mould-makers, etc. Bronze Forces, Hard Bronze and Iron Shells for Die-cutting Machines. Cast Iron Hub for sinking in Steel Dies. Chandler, Undercut Work, Statuary.
AUGUST GRIFFOUL 313 HALSEY STREET NEWARK, N. J.

ESTABLISHED 1886

GEO. M. BAKER

TELEPHONE UNION 1493-R

Gold and Silver Refiner and Sweep Smelter

Office, 91 Page St. }
Works, 77-85 Page St. } PROVIDENCE, R. I.

Our processes are strictly up to date and facilities most complete for doing all kinds of refining.
Specialties: Prompt and good returns.

A Few Words About Mainsprings



There is no article of material used by the watchmaker or the watch repairer about which, if he be a careful and thorough workman, he feels more solicitous than the *Mainspring*. Next to the fragile watch glass, the mainspring is more frequently replaced than any other article used in watch repairing. While the percentage of breakage is high in all watch springs, it jumps into appalling proportions when they are of an inferior quality, unless their temper is so low as to make them almost useless, and certainly of little value in watches that are to serve the purpose of timekeepers. When we offer you the *Ulysse Sandoz Robert* spring, we feel confident that you are getting the best that skillful hands and lifelong experience can produce.

Made for all American Watches. Per dozen, \$1.25

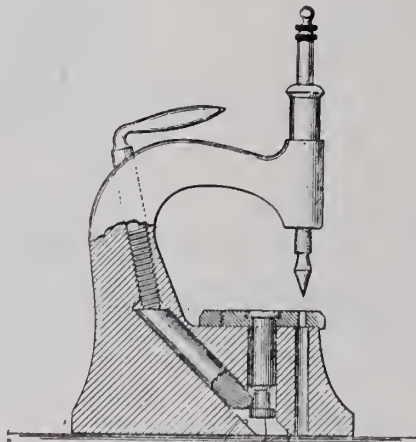

“Echarco” Staking Tool

100 Punch, 24 Stumps - - - - - Each \$16.00

This invention is a decided improvement in staking tools. In the usual construction, the die is held by means of an eccentric cam, which has always been found insufficient, and objectionable, as the blows of the hammer nearly always loosen the cam, and the die plate is permitted to tilt and move out of position. Any mechanic will see, at a glance, from the above sectional view, that a loosening of the bolt is an absolute impossibility, no matter how severe the pounding may be, and that the source of exciting staking tool troubles is entirely eliminated.

Spectacle and Eyeglass Strap Plier No. 105

Price, each, \$1.25

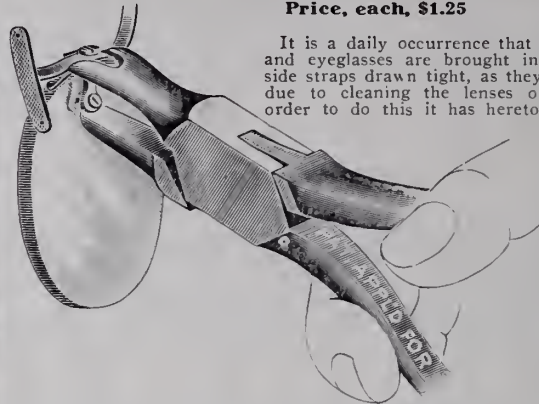

It is a daily occurrence that frameless spectacles and eyeglasses are brought in to have the small side straps drawn tight, as they have become loose, due to cleaning the lenses or other causes. In order to do this it has heretofore been necessary to remove the lenses from the mountings, and as all know, this very often results in breaking or chipping the lenses.

By the means of this plier this can be avoided and the work quickly done.

All that is required is to loosen the screw two or three turns, clamp the frame as shown in the illustration, and bend the straps to the lenses. Retighten the screw, and the work is done.

DO NOT NEGLECT to loosen the screw, as otherwise a good job cannot be done, and the lenses are likely to be broken.

Made of best quality Swedish steel, nickel-plated.

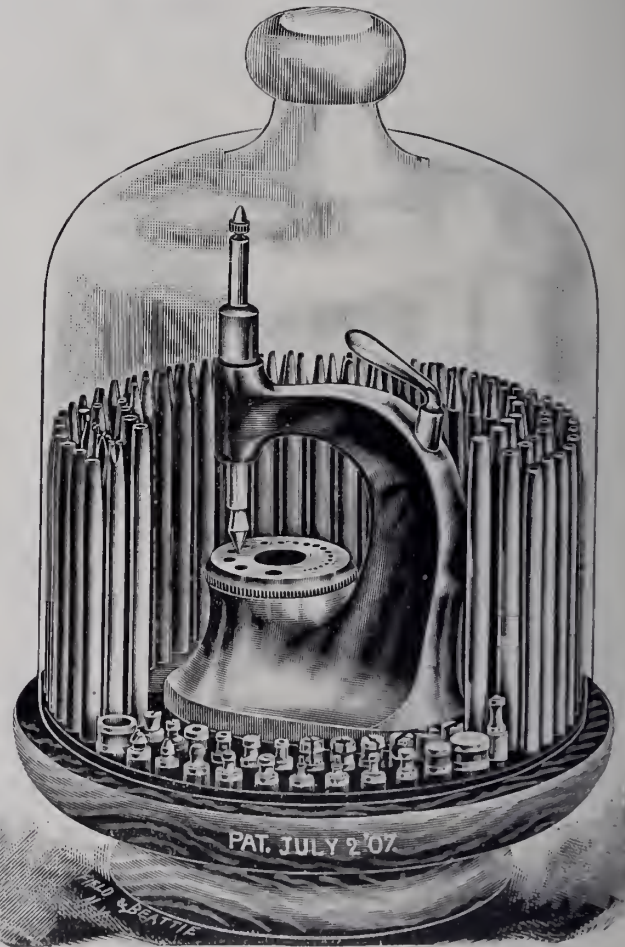

FOR SALE BY ALL JOBBERS IN THE UNITED STATES AND CANADA

HAMMEL, RIGLANDER & CO. 47-49 Malden Lane
New York

THE JEWELERS' CIRCULAR

WITH WHICH ARE CONSOLIDATED

THE HOROLOGICAL REVIEW,
THE JEWELERS' WEEKLY,
THE JEWELERS REVIEW

Copyright 1908 by
The Jewelers' Circular
Publishing Company.

11 John St., Corner Broadway, New York.

Entered as second-class matter at the New York, N. Y., Post Office.

40th Year.

WEDNESDAY, MARCH 4, 1908.

Vol. LVI. No. 5.



Original Design of Silver Plaque for International Automobile Trophy.

(See Text on Page 41.)

ALVIN SILVER

"ORANGE BLOSSOM"



ALVIN

MFG.

CO.



Gravy Ladle

Sterling
Silver

The true test of a design in table silver is the effect produced when the table is arranged for formal hospitality.

Pieces of the Orange Blossom design, shown above, make a most attractive group.

This design is made in over one hundred different articles, and is especially suited to wedding gifts.

It is made in sterling silver, stamped with the above trade-mark, and can be obtained from any jeweler, in sets or single pieces, to meet the requirements of complete service.

"BRIDAL ROSE"



ALVIN

MFG.

CO.



Gravy Ladle

Sterling
Silver

The true test of a design in table silver is the effect produced when the table is arranged for formal hospitality.

Pieces of the Bridal Rose design, shown above, make a most attractive group.

This design is made in over one hundred different articles, and is especially suited to wedding gifts.

It is made in sterling silver, stamped with the above trade-mark, and can be obtained from any jeweler, in sets or single pieces, to meet the requirements of complete service.

The two most appropriate patterns of Sterling Silver Flat Ware for wedding anniversaries. These patterns are being advertised in the leading magazines to stimulate trade, and so help the retail jewelers.

These magazines will be read in millions of homes all over the United States.

Be prepared to meet the demand. Complete your stock with fancy pieces and cutlery.

ALVIN MFG. CO., Silversmiths, NEW YORK



Fahys

Permanent Cases



The case which from absolute merit has won its place as the acknowledged leader of all gold filled watch cases.



Contains and will assay more gold value than any other filled case on the market at the same price.



All of our cases are made with our patent one-piece pendant, which eliminates all solder.



JOSEPH FAHYS & CO.

New York Boston Chicago San Francisco

"STRIKE WHILE *the* IRON IS HOT"

Make Money --
Good
Honest
Dollars



By buying diamonds from us you get the best value obtainable, so you can sell them at a fair profit, and at the same time give your customer proper value for his money

J. R. WOOD & SONS

DIAMOND CUTTERS

2 Maiden Lane, Corner 170 Broadway

NEW YORK

SAFETY



Perfect Safety

from dissatisfied customers is assured to those retail jewelers who handle our wedding rings.

Don't be left "out at sea" by selling rings not up to quality represented, or cast rings that do not wear properly.

We invite you to "ride ashore" to absolute safety.

J. R. WOOD & SONS

WEDDING RING MAKERS

2 Maiden Lane Corner 170 Broadway
NEW YORK

The Big Dipper

Will Dip Up Profits For You



THE
BEST IN EVERY
GRADE

CHICAGO
701 Heyworth Bldg.

Ask your Jobber

NEW YORK
Maiden Lane

STARWATCH CASE CO.

LUDINGTON, MICHIGAN

COPYRIGHTED BY T. F. KENNEDY



No. 69.



No. 48.



No. 40.



No. 61.



No. 64.



No. 63.



No. 71.



No. 67.



No. 73.



No. 51.



No. 44.



No. 66.



No. 99.



No. 22.

When you DO have a call for a fine Emblem Ring it is well to know that Wendell & Co. make the only line of high grade 14K. Rings on the market, that they carry a complete stock and gladly send a selection on memo. Their catalog shows illustrations of the entire line with list prices. They also make special Emblem Rings to order.

WENDELL AND COMPANY

The Special Manufacturers for the Retail Jewelry Trade

03-105 WILLIAM STREET, NEW YORK

57 WASHINGTON STREET, CHICAGO

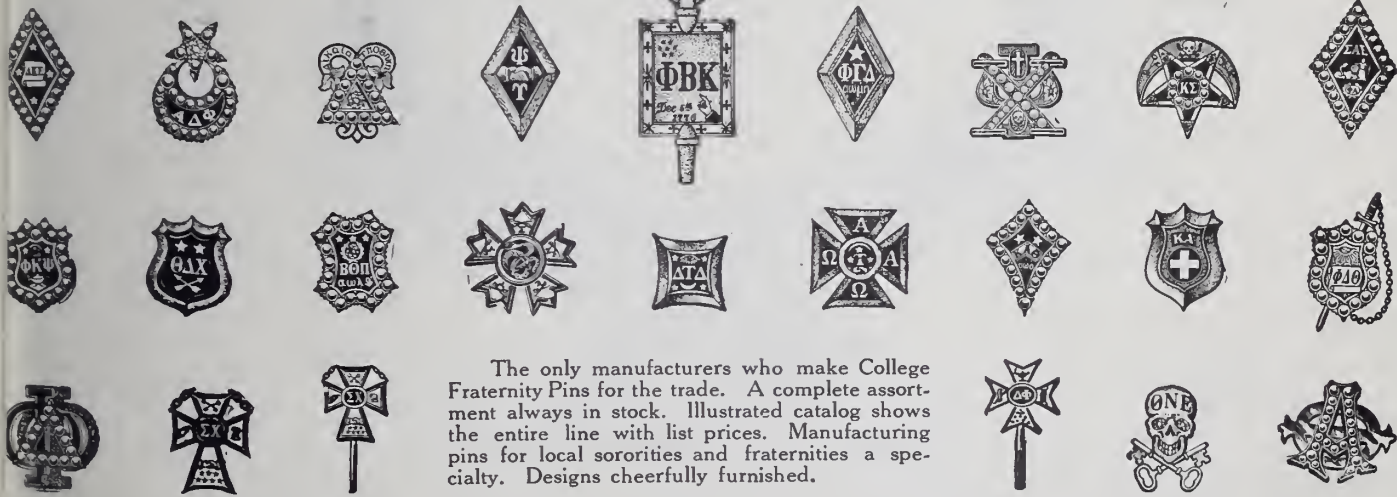

The only manufacturers who make College Fraternity Pins for the trade. A complete assortment always in stock. Illustrated catalog shows the entire line with list prices. Manufacturing pins for local sororities and fraternities a specialty. Designs cheerfully furnished.

HEINTZ BROTHERS.

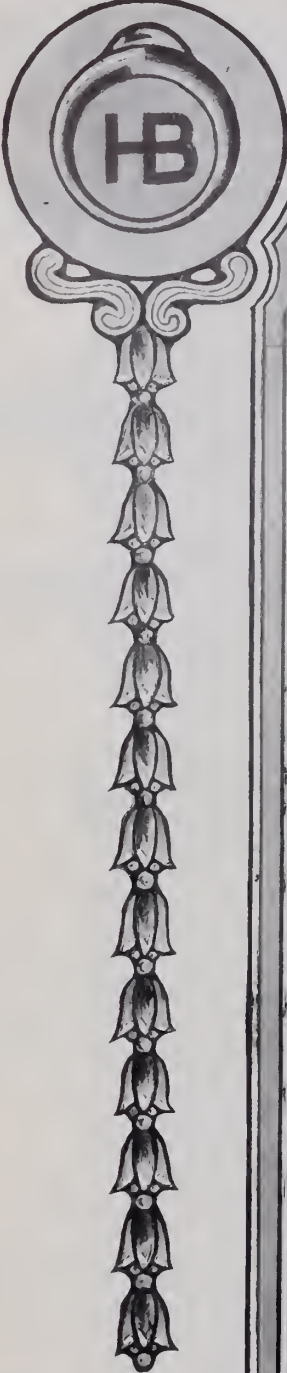

HB

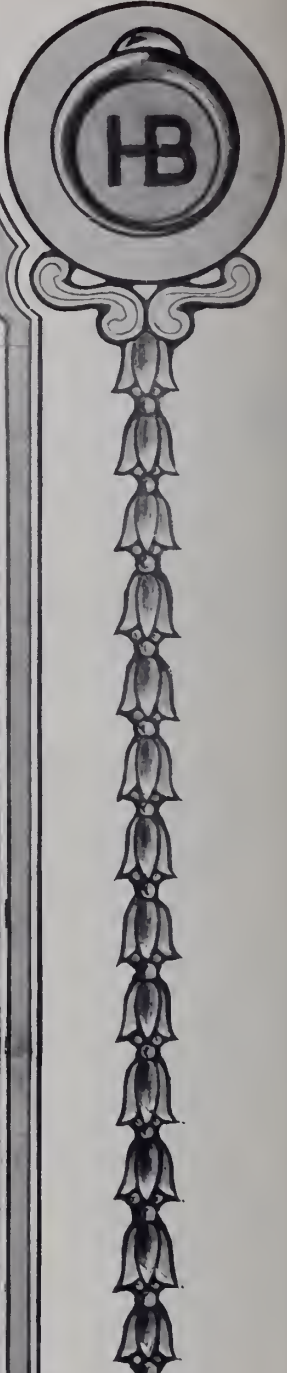

HB



**Start Your Spring Efforts
in the Right Direction
Buy HB Rings**

Our fiscal year just ended not only showed a great increase over the season previous, but proved to be one of the best in the history of our Company. Consistent effort in the right direction—the unlimited assortment of new designs, and quality of product—is responsible for this. The trade recognize that the **HB** Ring is the best selling—and therefore the most profitable—ring product in the market to-day.

HEINTZ BROS.
Buffalo, New York



JUST THE SAME AS EVERLASTING

ALL things must yield to Father Time—nothing is indestructible.
Yet it is quite true that

WADSWORTH PERMANENT

watch cases are “just the same as everlasting,” for they will wear so much longer than anybody expects them to that, in the end, they will be carefully laid away to be cherished with the other family heirlooms.

Chaste and artistic in design, perfect in workmanship and truly permanent, they represent the maximum of value, salability and satisfaction.

They would cost more if they were solid, but they would be no more attractive, nor would they give better service.

The Wadsworth Watch Case Co.

FACTORY
DAYTON, KY

CHICAGO
COLUMBUS BUILDING

SAN FRANCISCO
717 MARKET STREET

NEW YORK
49 MAIDEN LANE

Any Hour in the day, you can depend upon finding a Dueber case among these late designs, which will please your customer:

(25 yr 14 K.)

Hampden movements, from the dainty "Four Hundred" series for ladies, to the unparalled 16 size "Wm. McKinley," are cased at the factory.

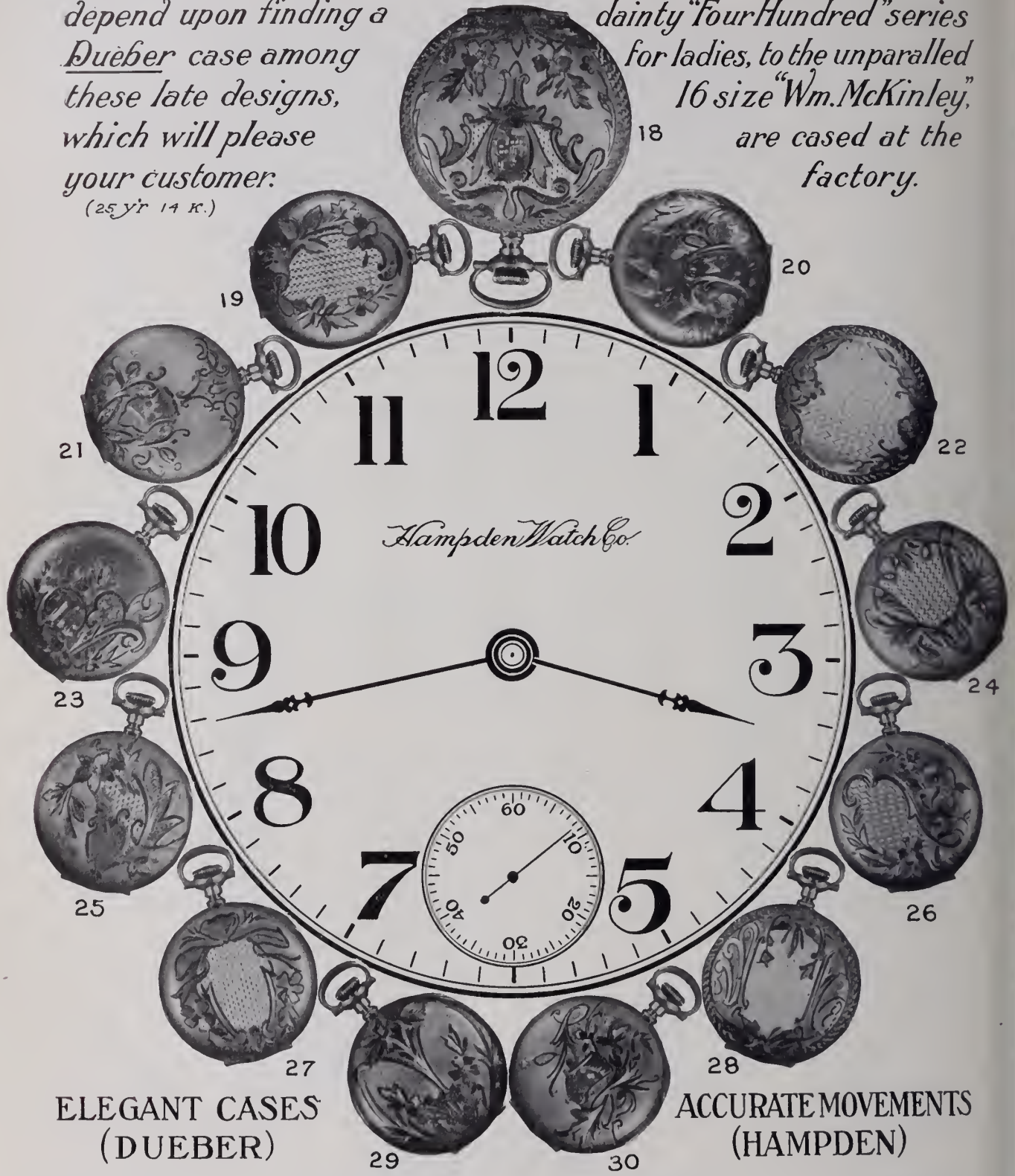

**ELEGANT CASES
(DUEBER)**

**ACCURATE MOVEMENTS
(HAMPDEN)**

WHITING MFG. COMPANY

Silversmiths



The Situation

The Whiting Company, being in close touch with the jewelry trade of the entire community, naturally find themselves exceptionally well informed as to the prevailing business conditions and sentiment.

This knowledge leads them to the belief that in these times of "close buying" it is incumbent upon the retail dealer to make his stock more than usually attractive by the addition to it of such goods as shall compel his customers' attention.

For this reason the Whiting Company have confined themselves this season to the production of such goods as shall be absolutely convincing, owing to their moderate price combined with their excellence of quality and individuality of design.

BROADWAY AND NINETEENTH STREET
NEW YORK



No. 1807

Makes Coffee on the Table

COFFEE MAKING MADE EASY

While the meal is being prepared the Sternau Coffee Machine is distilling the coffee.

It extracts only the wholesome qualities and makes a delicious beverage.

The popularity of the Sternau Coffee Machine is evidenced by our increased sales to the jewelry trade throughout the country.

You'll find Sternau Coffee Machines profitable to handle as they're salable *throughout* the year.

Our latest Catalogue No. 21, sent on request.

If It Burns Alcohol, We Make It

S. STERNAU & CO.

New York Showrooms
BROADWAY, COR. PARK PLACE
Opposite Post-office

*Makers of Chafing-dishes and their Accessories,
Smoking Sets, Alcohol Stoves, Fancy Tea-
kettles Coffee and Tea Pots, etc.*

Office and Factory
195 PLYMOUTH STREET
BROOKLYN, N. Y.



BEST IN THE WORLD FOR THE MONEY

THE D. F. B. CO. LINE

Ladies' and Gentlemen's Fobs

Lorgnette Chains

La Vallieres

Vest Chains

Dickens Chains Filled Rings

Carmen Bracelets

THE D. F. BRIGGS COMPANY

ATTLEBORO, MASS.

Purses for all Purses

WHY LOOK ELSEWHERE TO SUPPLY YOUR STOCK?

From the simple and inexpensive trinket of the unassuming to the most aristocratic and costly conceits. Each grade conceived to meet the taste of some one element of society and all together constituting a line of the greatest possible extent. In the designing, etching and engraving the whims of all the feminine world have been studiously consulted and artistically incorporated with the idea of producing something appealing and consequently easily sold.

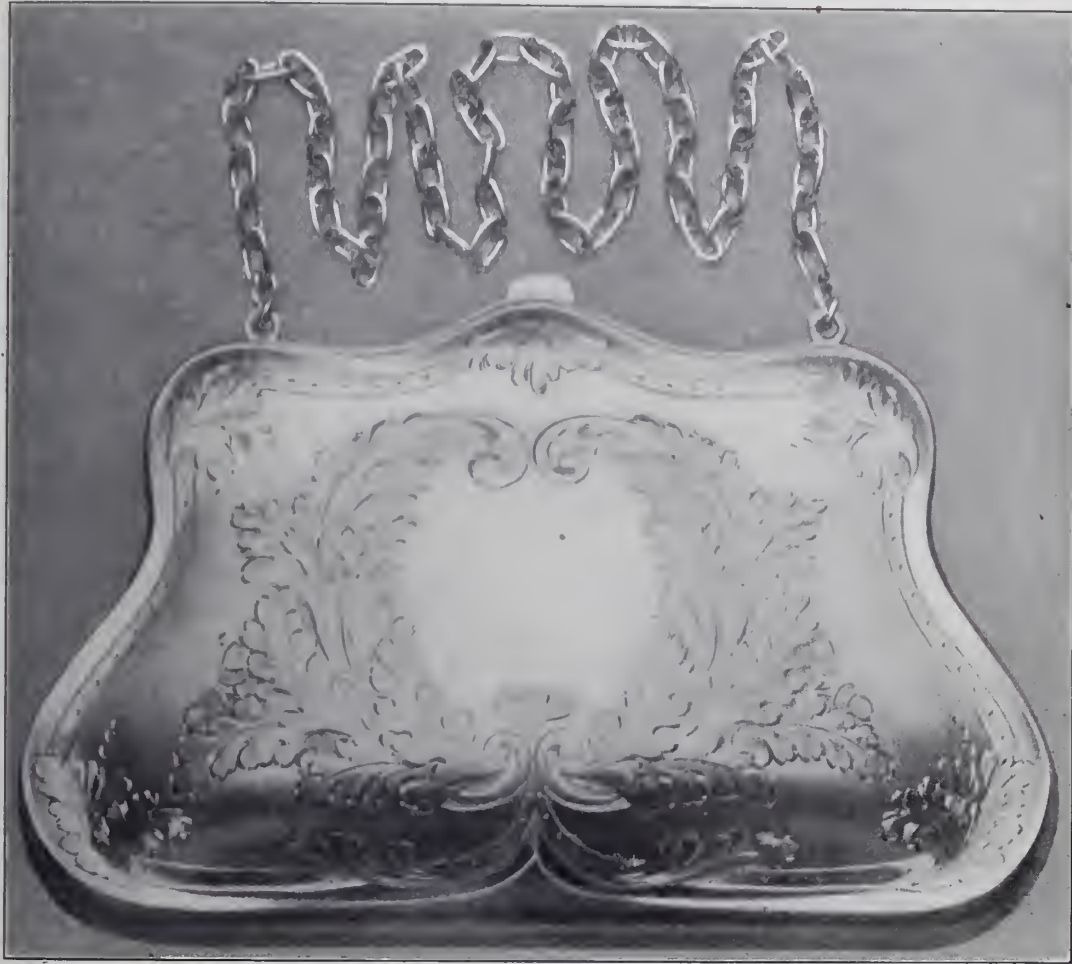

The line must recommend itself to the jeweler carrying combination purses and card case, and satchel shaped box purses, for the reason that we can supply these novelties in a practically unlimited variety, from the smallest to the largest made. We have oblong or satchel shaped purses with silk or leather linings; several sizes of vanity boxes, with silver compartments or leather lined, with puff, mirror, pencil tablet and change compartments, and many others, all of sterling silver, that we couldn't begin to enumerate in this space. See the line to understand it.

Representative jewelers are invited to send for a selection. State whether high, medium or low-priced goods are desired.

R. BLACKINTON & CO.

ESTABLISHED 1861. SILVERSMITHS

Factory, North Attleboro, Mass.

3 MAIDEN LANE, NEW YORK

TRADE  MARK

NEW YORK, 9 Maiden Lane
CHICAGO, 103 State Street

BATES & BACON ATTLEBORO MASSACHUSETTS

THE LEADING HOUSE FOR HIGH-GRADE GOLD-FILLED CHAINS, LOCKETS AND BRACELETS

Something New for Easter! THE "WINNA" BRACELETS
Strongest secret joint and catch on the market

SOME OF OUR NEW DESIGNS
ORDER OF YOUR JOBBER

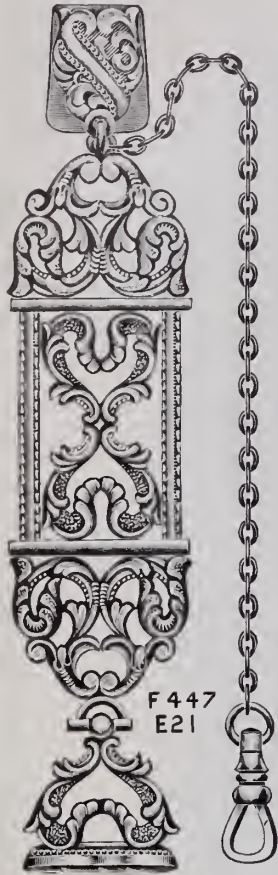

Gents' Vest
Dickens
Safety Fob
Secret Locket
Lorgnette
Eye Glass } Chains

BRACELETS, LOCKETS,
CHATELAINES



L.1260

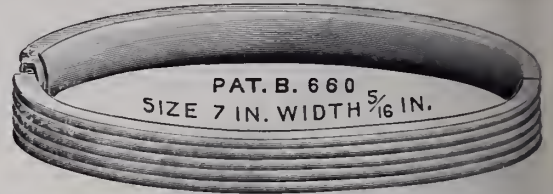

PAT. B. 660
SIZE 7 IN. WIDTH 5/16 IN.

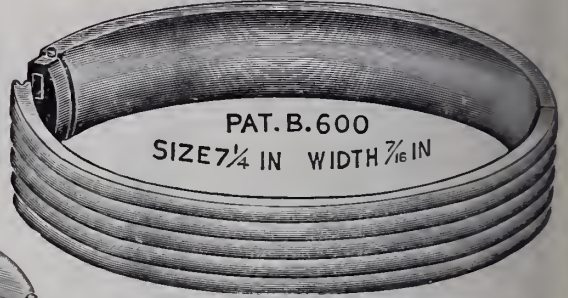

PAT. B. 600
SIZE 7 1/4 IN WIDTH 7/16 IN



PAT. B 662
SIZE 7 1/2 IN. WIDTH 3/4 IN.



PAT. B. 661

F 447
E 21

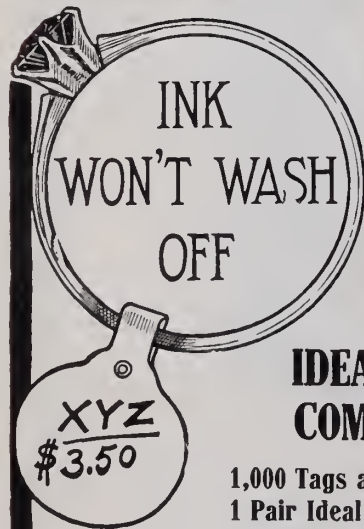

TAG YOUR RINGS WITH WASHABLE TAGS

IDEAL TAGGING OUTFIT COMPLETE, ONLY \$2.50

- 1,000 Tags and Eyelets, . . . \$1.50
- 1 Pair Ideal Pliers,75
- 1 Bottle Waterproof Ink,25
- 1 Neat Hardwood Box, with catch fastener

The IDEAL CELLULOID TAG is something that every jeweler should have, BECAUSE IT SAVES TIME—AND SAVES MONEY.

And because it gives your rings a more attractive appearance.

You don't have to take off the tags when you wash or polish your rings, because the ink that goes

with each outfit is waterproof, and won't wash off. No danger of getting the tags mixed and getting them on the wrong ring.

The Ideal has a large flat writing surface, which makes it better than any other tag.

A complete outfit only costs \$2.50. Better send for it to-day if you want it soon, for the demand is very large.

Bastian Bros. Co.
30 South Avenue, ROCHESTER, N. Y.

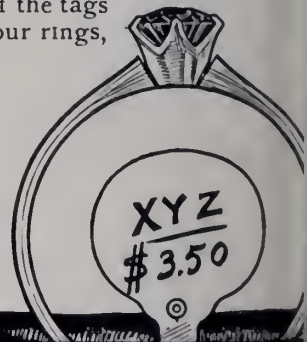
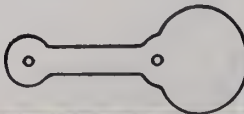

POSITION OF TAG WHEN RING IS IN TRAY

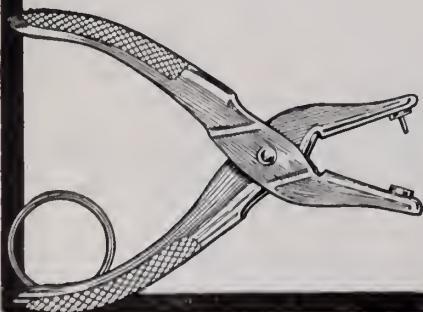



WE show herewith a new style bag—an exceptionally strong, stylish, snappy article.

Our new Spring line is complete—covering the entire range of bags—all shapes, all the different styles of mesh—the largest assortment of frames ever shown. Every piece stamped. W. & D. an absolute guarantee of satisfaction.

Your Jobber has them.

WHITING & DAVIS
PLAINVILLE (Norfolk Co.), MASS.

New York Office, 7 Maiden Lane

SOLD DIRECT TO THE RETAIL TRADE ONLY

FEATURES OF OUR LINE

The **UNIQUE, ARTISTIC** and **UNUSUAL**, together with **BEST WORKMANSHIP, SUPERIOR QUALITY** and **PERFECTION IN FINISH**



Brooches in gold filled or sterling silver, the gold filled finished in rose or dark green (antique). The sterling in French grey or oxidized. We use finest imitation stones and can furnish any stone or color required.

We Manufacture in GOLD FILLED and STERLING SILVER

BROOCHES, HAT PINS, COMBS, HANDY PINS, WAIST PIN SETS, BARRETTES, SCARF PINS, VEIL PINS, LINKS, BUCKLES, SASH BROOCHES, BRACELETS and NECKLACES.

C. RAY RANDALL & CO., North Attleboro, Mass.

NEW YORK OFFICE, No. 7 Maiden Lane

SAN FRANCISCO OFFICE, Henry M. Abrams Co., No. 717 Market Street

Address all orders and communications to Factory, North Attleboro, Mass.

The Scarab or Sacred Beetle

WROUGHT in cloisonne enamel with beautiful transparent and iridescent colors. Made in *Belt pins, Brooch pins, Hat pins, Stick pins, Cuff links* or *Watch fobs*. Prices from \$3.00 to \$36.00 per dozen.



This most ancient Egyptian symbol of good fortune is the best novelty of the season. Samples sent on approval.

The Shepard Manufacturing Co., Silversmiths, MELROSE HIGHLANDS, MASS.

Begin the New Year Right—Complete Your Stock with Right Goods

GOLD RINGS

Gold Scarf Pins Gold Brooches

A Handsome Line of Seamless Wire GOLD FILLED RINGS

All ready for prompt delivery to the Jobber

OSTBY & BARTON CO.
PROVIDENCE, RHODE ISLAND

New York Office
9-13 MAIDEN LANE

Chicago Office
103 STATE STREET

The Best Selling "Thread" Pattern in the Trade



The SMITH "PILGRIM"

There never has been a more artistic and lasting design than the Smith "Pilgrim." It is characterized by simple elegance, refinement and dignity of design, and grateful absence of over-ornamentation. The Smith "Pilgrim" pattern will remain permanently in demand. Include "Pilgrim" in your stock. It is without question the best selling "thread" pattern in the trade to-day. Made in all the fancy pieces.

FRANK W. SMITH CO. MANUFACTURERS OF STERLING SILVERWARE Gardner, Mass.



TRADE MARK



MARGUERITE

MR. RETAILER:

That department in our factory called: "CREATION CORNER" is working overtime.

We simply won't stop creating.

It is just as natural for us to create

SNAPPY GOLD WATCH CASES, as it is for a "live wire" to spit sparks.

Some of our prettiest creations will blossom in April and any Jobber will gladly send you a few.



MARGUERITE

Solidarity Watch Case Company

Established 1885

54 Maiden Lane, New York

General Selling Agents:

JOHN W. SHERWOOD

:: ::

FRANK E. HARMER

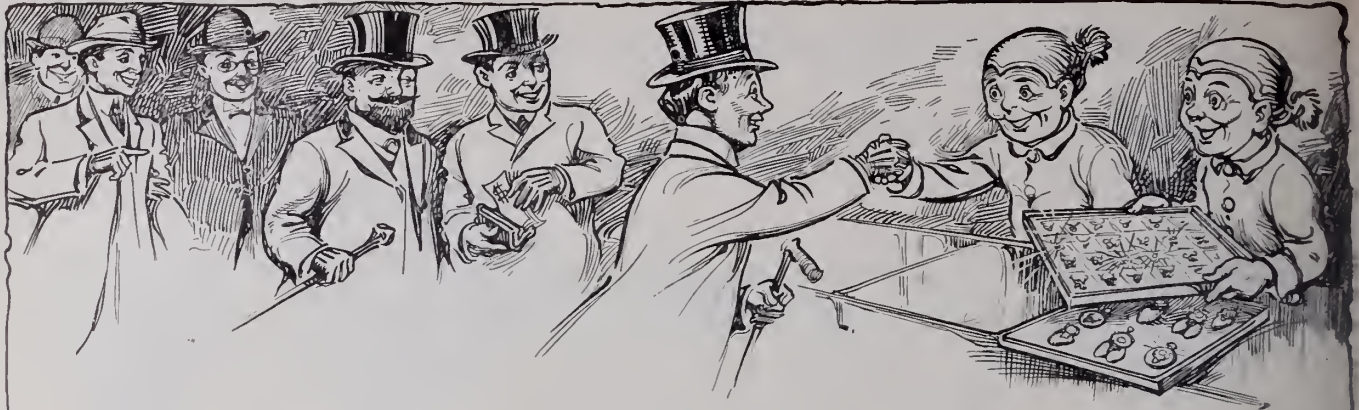

WE have noted quite an increased demand for Elk Jewelry, which is customary about this time, and throughout the Spring. Emblem goods are among the best "Sellers" the jeweler has and particularly so with the Benevolent Protective Order of Elk goods. Our assortment is larger than ever, many new patterns having been added, and you are welcome to selection package on request. We have a large number of extra fine charms suitable for Past Exalted Rulers and for presentation purposes generally.

An assortment of Elk emblems will help you to make sales, not only in Fraternal Jewelry but other articles, as all "Elks" are liberal buyers and good spenders. Write us any time about Elk Jewelry. We are headquarters.

HENRY FREUND & BRO.

Jewelry, Watches, Diamonds

71 NASSAU STREET, NEW YORK

The "Rose,"  our trade-mark, is a symbol of quality and excellence



THE CHARM OF NOVELTY is felicitously exemplified in these stylish Cases. The taste for "combination" is catered to in a new way. Fashioned of German Silver, rich effects are produced in

ENGINE TURNED DECORATION.

Such unique creations merit the special attention of the trade. Samples will be sent on request. Gun Metal Cases also for mourning or for the elderly. The appeal of the whole line is irresistible. Prices: from \$5.25 to \$7.50.

D. Lisner & Co. *Creating Importers of*
Jewelry Novelties
 One-Forty Fifth Avenue, cor. 19th St., NEW YORK

THE SILVERSMITHS BUILDING

17-19 MAIDEN LANE, EXTENDING THROUGH TO JOHN STREET

The largest, best situated and finest building in the world erected for the occupancy of jewelers, Silversmiths and kindred trades.

Designed by Clinton Russell.

At the centre of the wholesale Jewelry and Silverware trade of this continent.

Large frontage on Maiden Lane, with two connecting wings on John Street.

The only building with arcade extending through from Maiden Lane to John Street.

Express Subway Station within 150 feet of John Street Arcade entrance, and the new Hudson Terminal Station only one block distant.

The Maiden Lane front is 20 stories high. The John St. wing, west, is 12 stories. The John St. wing, east, is 10 stories.

Maximum daylight assured in all parts. North and East light in main portion and John St. wing.

Ready for occupancy May 1st.

Thoroughly fireproof throughout.



7 of the latest fast running type of Otis Traction Elevators. Three of the elevators are express, running from the first to the twentieth, with the first stop at tenth floor. Three are local elevators running from the first to the tenth floor, and one elevator running from the first to the twentieth, which may be used as a freight car or for safe lifting purposes.

Building lighted by electricity and heated by steam from street mains.

Vacuum cleaning system installed with an outlet on every floor.

The management of the building has been entrusted to the Gross & Gross Co., who upon completion will occupy offices upon the premises, in charge of Mr. Courtland E. Hastings, who is also the Secretary of the Maiden Lane Realty Company, owners of the building.

Until completion of the building Mr. Hastings can be found at 171 Broadway (entrance on Cortlandt St.) Room 5, where rentals are now being made for space in this building.

MAIDEN LANE REALTY CO., Owners

EDWARD HOLBROOK, President

Wolcott Manufacturing Co.



“Fashion”

Collar Pins



PATENTS PENDING

An Absolutely New Article which Sells at Sight. Try It.

MANUFACTURED IN ROLLED PLATE BY

Wolcott Manufacturing Co.

71 Peck St., Providence, R. I.

New York Office, 14 Maiden Lane

MANUFACTURED IN 10KT. SOLID GOLD BY

JOHN T. MAURAN MFG. CO., Providence, R. I.

SIMMONS ARMILLA

THE few examples here reproduced include some of the latest and most desirable patterns

in the Simmons Armilla line which the jobbers are showing, and are indicative of the variety and tastefulness of design which characterize the line as a whole.

Simmons Armilla is carried by a very considerable portion of the retail trade throughout the country, and the substantial orders and re-orders which the jobbers are receiving are the best index of its salability.

The **Armilla** has, in fact, won wide recognition as the best and the readiest selling of the secret joint and catch bracelets. It is the nearest approach to perfection that has been attained in this type of bracelet, its simplicity and durability of construction being equaled only by the beauty of the designs and the finish and its generally attractive appearance.

AMONG the goods that must be carried at all times and which are salable at all seasons—irrespective of Fashion's whims and caprices—none are more staple or more safe to have in stock than SIMMONS CHAINS and FOBS.

Look over the latest Simmons Patterns at the jobbers' if you would know what are to be the best sellers the coming season.



R. F. SIMMONS COMPANY
Main Office and Works, ATTLEBORO, MASS.

New York Salesrooms
9-13 Maiden Lane

Chicago Salesrooms
42 Madison St. (Heyworth Bldg.)

The KREMENTZ MATCH BOX

made expressly for paper matches, in 14-Kt. Gold and Sterling Silver, with the following finishes:
Roman, polished, engraved, engine turned and the Krementz gun metal finish.

Open



Side View
Closed



Order No.
in 14-Kt. Gold
2117

Front View
Closed



Order No.
in
Sterling
Silver
2043

The side and front views show its compactness. It opens and closes easily and fits the vest pocket, taking very little space.

KREMENTZ & CO.

Manufacturers of

Fine Gold and Enamel Diamond Jewelry in 14-Kt. Only

MADE EXCLUSIVELY FOR FINE RETAIL JEWELRY TRADE

BRANCH
San Francisco Office
722 Shreve Bldg.

Factory and Main Office
NEWARK, N. J.

BRANCH
New York Office
1 Maiden Lane

THE VIRTUES OF FLAT BACK STUDS

TRADE



MARK

THE PLAINEST and simplest is the stud for a gentleman. To these virtues the Flat Back Studs add the element of comfort. They are least likely to chafe the flesh or wear the underclothing. Points your best customers will appreciate.

TRADE



MARK

DURAND & CO.

49-51 FRANKLIN STREET
NEWARK, N. J.



ENOS RICHARDSON & Co.

MANUFACTURERS OF

14-K GOLD JEWELRY

TRADE MARK.



- HANDY PINS
- TIE CLASPS
- SAFETY PINS
- VEIL PINS
- BROOCHES
- HAT PINS
- FLAT LINKS
- SCARF PINS
- DUMB-BELL LINKS
- BARRETTES
- FOBS
- BELT PINS

10-K AND 14-K NECK CHAINS AND GUARD CHAINS

PLAIN AND JEWELLED LORGNETTE CHAINS

23 MAIDEN LANE, NEW YORK



The R. S. Cigar Cutter

In Sterling Silver, Plain and Engraved; and 14 k. Gold, Plain and Engraved, also Set with Diamonds.

A Novelty

Unlike all other cigar cutters, this one lies flat in the pocket—does not get out of order.

A Good Article



We Push It

Our advertising makes the customer want it; his friend see it and he wants it. An endless chain of customers.

A Good Seller



Trade supplied by

Enos Richardson & Co.
23 Maiden Lane, New York.

G. R. HOWE
W. T. CARTER
W. T. GOUGH

ESTABLISHED 1841 BY A. CARTER

F. R. HORTON
F. W. STANBROUGH
H. L. FARROW

CARTER, HOWE & CO.

MANUFACTURERS OF

GOLD JEWELRY

Bags and Purses in Gold and Silver

9-11-13 Maiden Lane, New York

Factory, Newark, New Jersey

ABEL BROS. & CO.

64-66 JOHN STREET
Corner William Street
ABEL BUILDING
NEW YORK

Branches at LONDON—PARIS—AMSTERDAM—ANTWERP—IDAR—OBERSTEIN

Diamond Mounted Jewelry

Loose Diamonds, Pearls
Rubies and Sapphires

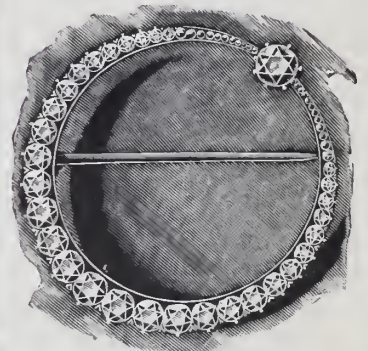
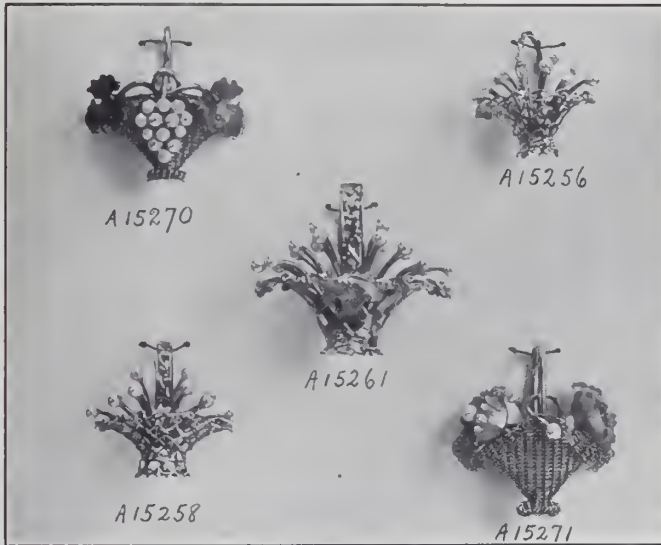

ORIGINAL DESIGNS

Fine Diamond Mountings

L. BONET, CAMEO PORTRAITS,



Importer of Precious Stones,
41 Union Square, NEW YORK.

HILL & SCHMIDT

71 Nassau Street

NEW YORK

Makers of Artistic 14 kt. Jewelry

SPECIAL DESIGNS IN

LA VALLIERES and HANDY PINS



Start Right

Quality rather than price should be considered in selecting merchandise. A customer pleased is the best advertisement. We want your trade to-morrow as well as to-day.

THE KELLER JEWELRY MFG. CO.

Manufacturers of Fine Gold Jewelry

Brooches, Link Buttons, Locketts, Scarf Pins, Combs, Fobs, Tie Clasps, Charms, Lorgnette Chains, Neck Chains

64 NASSAU STREET, NEW YORK

Factory, 251 N. J. R. R. Avenue - - - NEWARK, N. J.

BUY GOODS WITH A TRADE-MARK



BANGLES
BROOCHES
BANGLE BRACELETS

HANDY PINS
TIE HOLDERS
VEIL PINS

A General Line of Fine Jewelry

BIPPART, GRISCOM & OSBORN

OFFICE AND FACTORY
Newark, N. J.

NEW YORK SALESROOM
1 West 34th St.

Insure Your Life

L. A. Miller

Special Agent of the

Equitable Life Assurance Society

will show to any who may be interested Sample Annual dividend policies on the

LIFE, LIMITED PAYMENT, ENDOWMENT, and TERM PLAN

ADDRESS

L. A. Miller

Special Agent

180 Broadway, N. Y.



No. 58

THE ARCHIBALD-KLEMENT LINE OF

SILVER DEPOSIT WHISKY BOTTLES

Distinguishable for their dignity of design and excellence of finish. Made in full quart size, four designs—Narrow Strap, Broad Strap, Rye, Thistle. Shield space for monogram, sterling silver cork-screw tops. Highball and whisky glasses to match each design.

Full line of the foregoing, and any other desired pieces in the A-K Silver Deposit Ware, sent on approval.

ARCHIBALD - KLEMENT CO.
Sample Rooms: 341-347 Fifth Ave., N. Y.
Factory: NEWARK, N. J.

Ludwig Nissen & Co.

182 and 184 BROADWAY
NEW YORK

PEARL
NECKLACES
AND
DIAMOND
COLLARETTES

Mounted Diamond
Jewelry of Every
description :: ::

Largest assortment
of all kinds of very
fine, fancy and rare
gems, including
Pearls, Diamonds,
Emeralds and
Sapphires :: ::

PARTICULARLY
FANCY COLORED
AND FANCY
SHAPED DIAMONDS

Ludwig Nissen & Co.

182 and 184 BROADWAY
NEW YORK

NEW DESIGNS IN

HANDY PINS



Made in all colors
and finishes



Greatest variety of
designs and
sizes



TRADE-MARK

A. J. HEDGES & CO.

Makers of Exclusive Designs
in High Grade 14K. Jewelry

14 JOHN STREET, NEW YORK

Links for Summer Shirts

APPROPRIATENESS is a virtue. There are
Links that seem to belong to the Summer
shirt. These Gem Links are an example. They
strike the true note of color. Stones:

AMETHYST, TOPAZ, GARNET
CHINESE JADE, NEW ZEALAND JADE

Scarf Pins to match emphasize the pleasing
harmony. Good selling lines appealing to gentle-
men of taste.

... Scarf Pins to Match ...

Day, Clark & Co.

MAKERS OF 14-KT. JEWELRY
23 MAIDEN LANE
NEW YORK



THE HAGERSTROM CO. (Incorporated)

Makers of
14-K Jewelry



¶ We are always adding something new and salable to our large line. We have no particular leaders as all our designs are not only original and up-to-date but beautifully made and finished.



No. 1093.

Office and Works
276 N. J. R. R. Ave.
Newark, N. J.



¶ Our Necklaces and La Vallieres are sellers, because they are made at a price that will appeal to the careful buyer. *Seeing is believing.* Also included in our Spring offerings are Link and Cuff Buttons, with Scarf-pins to match, set with a variety of stones.



No. 325.

Finished in Rose and Enamel



No. 326.

Set with Amethyst, Jade, Amazonite, Red and Green Sardonyx, etc.



No. 324.

Set with Half Pearls and Enamel

**MANUFACTURER OF HIGH-GRADE
DIAMOND MOUNTINGS**

Prompt Attention
Given to Special
Order Work :: ::



Patented October 24, 1905.

Estimates and
Designs Submit-
ted :: :: :: ::

DIAMONDS RECUT AND REPAIRED

JULIUS WODISKA, 40 John St., New York

"THE BRACELET HOUSE"

GOLD BRACELETS of every kind
For WOMAN, MISS OR BABY

KENT & WOODLAND

16 John Street, New York

Factory: Newark, N. J.

San Francisco: Julius A. Young



**SOLID
GOLD COMBS**

From \$1.50 Upward

A Snappy New Spring Line

in
Plain and Engraved Bands,
also

New Effects in Pierced Tops

14k.—Everything in Gold Jewelry—10k.
Brooches, Barrettes, Buckles, Bracelets,
Pendants, Festoons, Emblems, Hat
Pins, Fobs, Scarfs, etc.



2 Maiden Lane,

New York

INFORMATION

The right kind of information—the kind that will help you in your daily business work—information that will save you many a dollar is found in our Yearly

GREAT

American Jewelry Catalogue

ASK FOR IT

THE OSKAMP NOLTING CO.

Mammoth Wholesale Jewelers

419-415-417 Elm Street CINCINNATI, OHIO

**Don't Worry About the
Scarcity of Money**

¶ If you need any send us your surplus stock of Diamonds, Watches, Jewelry, Old Gold and Silver, and get our certified check by return mail. If amount is not satisfactory goods will be returned in same condition as received. Strictly confidential. Correspond or call. Telephone, 5202 John.

New York Jewelry Purchasing Co.
106 Fulton Street, New York

TRADE



MARK.

SNOW & WESTCOTT

21 MAIDEN LANE, NEW YORK

JAMES P. SNOW

CHAS. E. WESTCOTT

Makers of Fine Gold
Jewelry

ESTABLISHED 1834

THE BEST
SOLID GOLD CHAINS

THE CHEAPEST

They stand the test of time and have done so for 56 years.

Supreme in
QUALITY DESIGN FINISH WORKMANSHIP



We Sell Direct. We Have No Salesmen. Eliminating all unnecessary expenses in making and selling enables us to sell at the lowest possible price. Send for catalogue.

Trade  Mark
1850 1907

ALOIS KOHN & CO.

16-18 Maiden Lane, New York

Makers of **Gold Chains** of every kind

ARRAUD & GRISER

68 & 70 Nassau St., New York

LAPIDARIES. PRECIOUS STONES
GEMS in Unique Cuttings

UNIQUE GEMS

SEMI-PRECIOUS CEYLON, URAL and NATIVE

GEMS My Specialty

Prices the Lowest. Sample Papers sent on Request to Reliable Jewelers and Manufacturers.

Louis J. Deacon, Atlantic City, N. J.

I. N. LEVINSON, President

ESTABLISHED 1865

H. S. MORRIS, Sec. and Treas.

S. COTTLE COMPANY

Makers of High-Grade Gold and Silver Novelties

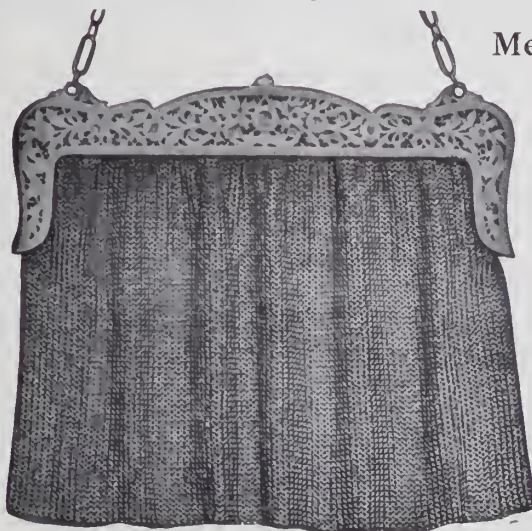

Mesh Bags Buckles
Card Cases
Vanity Cases
Purses Chatelaines

Our new line for Spring is now ready for inspection. Many new and artistic designs are shown. We wish to thank our many patrons for their past favors and hope for a continuance in the future.

31 EAST 17th STREET, NEW YORK

PARIS, 28 Rue D'Hauteville

FRANKFURT a M., Hanse-Haus, 9 Stiffstrasse



ACTUAL SIZE.

SEED-PEARL NECKLACES IN ALL SIZES.

OSMERS-DOUGHERTY CO.

MANUFACTURING JEWELERS

291-293 SEVENTH AVE., NEW YORK

Bet. 26th and 27th Sts. Telephone, 913 Madison.

DEALERS IN **BAROQUES, PEARLS and FANCY STONES**  **DESIGNING AND SPECIAL ORDER WORK**

10K. EMBLEM GOODS

CHARMS
LAPEL BUTTONS
LOCKETS
EAGLE
ELK
ODD FELLOW
MASONIC

CHARMS
LAPEL BUTTONS
LOCKETS
EAGLE
ELK
ODD FELLOW
MASONIC



Schultz & Co., Inc.
Makers of "Business Builders"

An up-to-date line of 10K. jewelry of all kinds

Factory and Office
91 Oliver St., Newark, N. J.

Trade Mark



New York Salesroom
12-14 John St., N. Y. City

We also make a line of Ladies' Brooches in Elk and the different Masonic Degrees

After July 1, 1908, this Company will change its name to

Percy M. Layman **LAYMAN & STRAUS CO.** Sydney C. Straus



327

S. PITZELE

Established 1893
51-53 Maiden Lane NEW YORK
Manufacturer of



306

FINE
Diamond Mountings
ALSO
Bracelets
AND
Dwt. Goods



688

SPECIAL ATTENTION GIVEN TO ORDER WORK



325



329



218



435



348

S. F. Myers & Co.
WHOLESALE JEWELERS
47-49 Maiden Lane
New York

Leadership counts for as much in business as in great battles. We are leaders in our business.

For the trade only—our new, big catalogue, with 100,000 items, sent free.



Monograms
INITIALS AND FOBS
Our Specialties
Write for Catalogue Prices and Discounts.

CHICAGO ART METAL WORKS
63 Lake Street
CHICAGO, ILL.

“If It Is Chopard’s Idea, It’s Ideal”

MERIT, is the quality which singles out whatever is worthy of notice. That Chopard’s productions have merited this distinction is not because we say so, but because our records show a growth, year by year, which speaks eloquently for the sterling quality of our wares.



To single out from our newest importations any one, or a few articles, would be unjust to the others, so we call your attention to our line in general and these in particular:

Fancy Combs, Brooches, La Vallieres, Hatpins, Buckles, etc., also our complete assortment of **Jet Jewelry** and **Pearl Strings**.

Selection Packages sent upon request to all reliable dealers.

CHOPARD FRÈRES

Factory, 35 Rue des Trois Bornes, PARIS, FRANCE

NEW YORK, OFFICE
56 Maiden Lane

Send for the Latest Styles in
MONOGRAMS AND INITIALS

as manufactured by
THOMAS J. DUNN CO.



101 Chambers St., New York
Makers of exclusive styles in
MONOGRAM FOBS

in Gold, Sterling and Rolled Gold Plate. Our 1908 Ladies' Belt Buckles are most original and artistic.

Specialties in the Monogram and Initial line.

Send for Illustrated Sheets.



10K. GOLD BRACELETS

New and Original Designs in—
BANGLE, JOINT
AND
CATCH SIZES

Scarf Pins, Ladies' Rings
Earrings and Handy Pins
in a great variety of designs

TRADE MARK

THE
Edwin Lowe & Co., Inc.
F.W. BODWELL, Pres. & Gen. Mgr.
116 Chestnut St., PROVIDENCE, R. I.
New York Representative: Western Representative:
E.T. Wilson, 180 Bway. S. H. Brower

J. H. GALAWAY P. H.
ENGRAVERS
CRESTS, MONOGRAMS and LETTERING
7 Maiden Lane, Rooms 44-45
Established over 35 years

The Allsopp Rings

The Up-to-Date Line of **Signet and Set Rings**



In twenty years we have built up a business second to none in RINGS EXCLUSIVELY

Allsopp

QUALITY,
DESIGN AND
WORKMANSHIP

Appeal to the Most Fastidious.
It Will Pay You to Examine
a Selection Package.

A ★
TRADE-MARK.

Allsopp Bros. Allsopp Building, Newark, N. J.



NECKLACE No. 540

Lapis,
Amethyst,
Quartz,
Spanish Topaz
Amazonite.

Price, \$4.50

Illustration half size

Hand Made Sterling Silver Real Stones

INNUMERABLE DESIGNS

CORAL CAMEOS—NECKLACES

BELT PIN or BUCKLE No. 884



Lapis, Amazonite, Spanish Topaz,
Amethyst. Price, \$4.00

VAN DUSEN & STOKES CO.

1123 Chestnut Street, PHILADELPHIA, PA.

The Bowden Rings

ARE COMPLETE IN VARIETY, CORRECT IN
QUALITY AND PERFECT IN FINISH. WE
MAKE EVERY VARIETY OF FINGER RINGS.

J. B. BOWDEN & CO.,

1 Maiden Lane.

NEW YORK.

THE CROHN PATENT SAFETY GUARD



For Scarf Pins
ins. The most
adjustable one invented. Price, \$1.50 per doz. For sale
y all wholesale jewelers and material houses. Sample
y mail, 25c.; in 10k gold, \$1.00; 14k., \$1.25. M. CROHN
aker and inventor, 48 and 50 Maiden Lane, N. Y.

Studs and Lace
practical and only



Geo. O. Street & Sons

35 Maiden Lane, New York

Established 1837

RINGS
SLEEVE-LINKS
SCARF-PINS
FOBS AND SEALS



CAMEOS

Stone, Shell, Coral and Lava.
Rolled Gold Plate Mountings

SELECTIONS SENT TO
RELIABLE JOBBERS

Maintien Brothers & Elliot
North Attleboro, Mass.

LOCKETS ONLY

Registered



U. S. Pat. Office



Pat. Applied for
NUMBER
8482

Latest Design Appropriate for Easter

WIGHTMAN & HOUGH CO.

NEW YORK OFFICE
3 Maiden Lane

Main Office and Factory } 7 Beverly St.
PROVIDENCE, R. I.



SHUROLDA



Automatic Scarf Pin Protector



14 Kt. Gold Plate

Price 50 Cents

To Release Pull the Ball

To Release Pull the Ball

Pat. Mar. 12, 1907.
No. 847,164.

The Stronger the Pull the Firmer It Holds

Pat. Mar. 12, 1907.
No. 847,164.

Samples and Prices on Application

FOR SALE BY JOBBERS OR DIRECT BY

STERN & CORN, 71-73 Nassau St., NEW YORK

CHARLES M. PRIOR, Designer

We have ready many new designs. Call or write. Etching is more popular than ever and we do it in the finest style.

'Phone 1639 Gramercy

24-26 East 21st St., NEW YORK

P & B FOBS

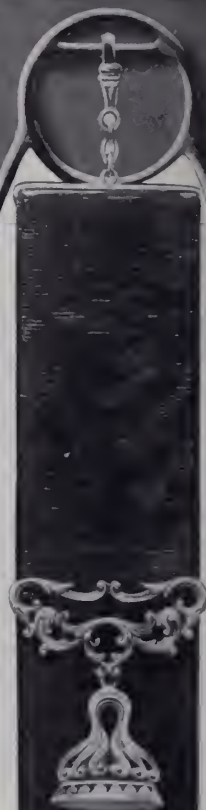

ALL STYLES AND PRICES
BOTH RIBBON AND ALL GOLD

WE ARE THE LARGEST EXCLUSIVE MAKERS OF OUR JEWELRY
ASK YOUR JOBBER FOR THE P. & B. LINES OF
Cuff Buttons Crosses Tie Clasps
Brooches Fobs Baby Pins
Beadnecks Locketts Bracelets
NEW YORK OFFICE 68 NASSAU ST.

POTTER &
BUFFINTON CO.
PROVIDENCE, R. I.

O. M. DRAPER CHAINS

ALL KINDS OF VEST CHAINS
PRINCESS, NECK AND GUARD CHAINS

We do not make as much noise as some of our friends but we are "there with the goods" and the *Jobbing Trade* handling our product for the last half century, know that our QUALITIES are genuine and can be depended upon, that our FINISH is unparalleled and that our prices are consistent.

If you do not handle O. M. DRAPER GOODS, we both lose.
We sell only to the Jobbing Trade.

Estate of O. M. DRAPER
Factory, No. Attleboro, Mass.

NEW YORK OFFICE
37 Maiden Lane

SAN FRANCISCO
506 Chronicle Building

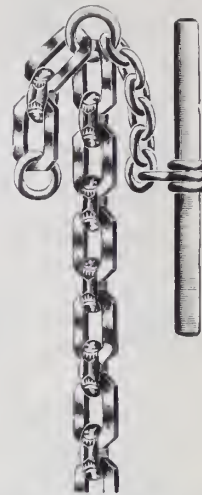

DIES

We are continually preparing new designs for jewelry, silverware, medals, emblems, brass goods, etc. Over 300 satisfied customers are our best recommendation.

Write us and tell us your needs. Let us submit a selection of designs subject to your approval.

Crees & Court

DIE SINKERS

21 Eddy Street PROVIDENCE, R. I.

DIAMOND MOUNTINGS

of any description in gold and platina

Order Work a Specialty

HENRY BASCHKOPF

47-49 Maiden Lane

New York, N. Y.

Roger Williams Silver Co.,

PROVIDENCE, R. I.

Sterling Only.

RICH DESIGNS :: :: :: Photos. on Application.

Try Wells' Perfect Ring Adjusters

1 doz. asst. sizes 10k gold filled (gold on front twice as thick as on back), \$2.00.
1 doz. asst. sizes solid 10k gold, \$3.75.
1 doz. asst. sizes, metal, 85c. Ask your jobber for them, or I will send, prepaid, at once (only on receipt of price), two samples—one small and one medium large gold filled and one metal adjuster for 50c. Address



CHESTER H. WELLS, Jeweler, Meshoppen, Pa.

Women of fashion at present are wearing ornaments for the hair more than ever. We anticipated such a demand for these goods and have on hand a large assortment of Rhinestone, Coral and Jet

BARRETTES

from which to select. We also have a magnificent line of Coral Hat Pins, embodying many catchy designs, exclusive carvings and filigree effects, ranging in price from \$4.00 to \$15.00 per dozen.

SELECTION PACKAGES SENT UPON REQUEST

M. GUGENHEIM, Importer of

Brooches, Festoon Chains, Combs, Hat Pins, Collars, Jet Goods, Mesh Bags, in German Silver, Gilt Metal and Sterling

NEW YORK OFFICE: 33 Union Square, Decker Building

PARIS: 32 Faubourg Poissoniere



While your business is somewhat dull you will find it to your advantage to look up the local order for

CLASS PINS

Write us for Catalogue J 30, and Samples

THE CHAS. M. ROBBINS CO.

MANUFACTURING JEWELERS AND ENAMELERS
ATTLEBORO, MASSACHUSETTS

OCTAGON—Suitable for 12 Rings

WE MANUFACTURE

Fancy Platforms and Blocks for Window Display.
Trays for Show Cases and Travelers' Use of every description.
Jewelry Boxes in many qualities and styles.
Boxes for Silverware, Manicure and Toilet Sets.
Silverware Chests in any combination.
Flannel Rolls and Bags for Silverware.
We Re-cover Window Platforms and Trays.

PAPER BOXES.

Tags, Cards, Cotton, Findings, Etc
Estimates and Samples Cheerfully Furnished

WOLFSHEIM & SACHS

Office and Salesroom: 35 Maiden Lane, New York
(Lorsch Building)
Factory: 10 Gold Street, N. Y.

EASTER OFFERING

When So Many Jewelers
Are Buying

VERIBEST

Label Inside

LOCKETS

Might It Not Be Worth
Your Consideration?

ELK TEETH

Unmounted, genuine. Bought of Indians, 10 to 300, as needed sent on selection to responsible Jewelers at strictly wholesale prices; also

EAGLE, MOUNTAIN LION AND LYNX CLAWS.

L. W. STILWELL,
DIEDWOOD, - SOUTH DAKOTA
Wholesaler of Sioux Indian Bead-Work and Curlo Supply Jobber.

C. VAN SCHOOR

MANUFACTURING JEWELER
AND REPAIRER

Best Workmanship. Lowest Prices. Jewelry Findings and Supplies. Importer of Jobbing Stones. Our findings are made of first quality, seamless stock, in all grades, direct from manufacturer to retailer. Our terms are cash. Give us a trial on repair work or send for booklet. Mail orders and repair work filled same day as received.

2041 W. 45th St., Cleveland, Ohio

WATCH REPAIRING

FOR THE TRADE

Careful, Reliable, Prompt Work. Trade References. Price List on Request.

A. D. PAPIAZI
71-73 Nassau St., Cockroft Bldg. NEW YORK

LEDERERMAK LOCKETS

Exclusively sold by **VERIBEST** Jobbers Everywhere

Manufactured and Guaranteed by
S. & B. L. ★ CO.

Established 1870 New York City 9-11-13 Maiden Lane	Providence, R. I. 100 Stewart Street	Famous 1908 Chicago, Ill. 131 Wabash Avenue
---	---	--

Orders Prove Our Goods Sell

Q We make for the Jobbing Trade the following lines of Solid Gold Jewelry:

Rings, Scarf Pins, Studs, Brooches, Charms, Baby Pins, Handy Pins, Chain Sets, Link Buttons, Hair Barrettes, Crosses, Ear Screws, Pierceless Drops, Cameos in all styles, etc.

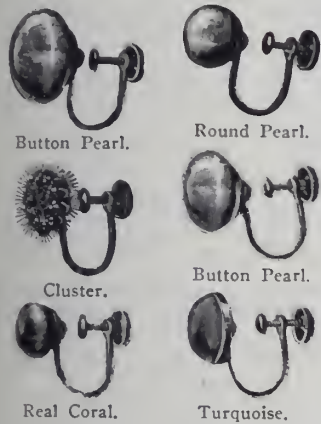

Insist upon seeing the designs of Gold Jewelry made by the

E. L. Spencer Company

95 CHESTNUT STREET
PROVIDENCE, R. I.

NEW YORK OFFICE
9-11-13 MAIDEN LANE

(SAMPLES ONLY)



WE have called the trade's attention to "The Spoon Family" and have sent many samples. Why not get in line and carry goods which are great sellers?

"The Whole Family"

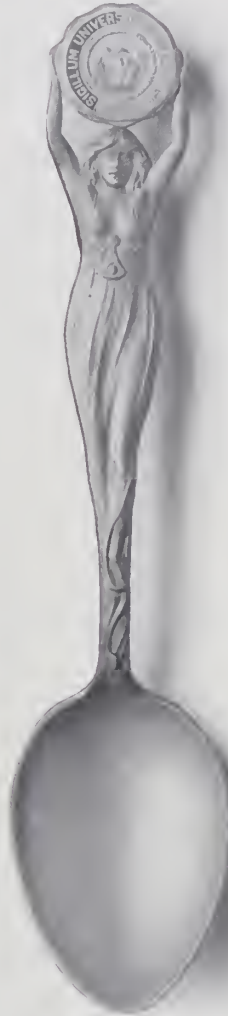

Now is the time, Mr. Retailer, you need sales. Carry goods made by us, and you have the assurance of large sales of College Jewelry.

OUR customers never have shcp-worn goods to be refinished.

THE KINNEY CO. Main Office and Factory, 14 Blount St. PROVIDENCE, R. I.



WE MAKE

The Alliance Ring

The graceful style of the Alliance Ring is rapidly supplanting the use of the old style wedding ring. The joints are invisible, and whenever engraving is desired it is done in the inside surface. Can be easily separated by inserting a pin in inside pin-hole.

14 karat, 3 dwts., each, \$1.25 per dwt. ; in dozen lots, \$1.15 per dwt., net.
18 karat, 3 dwts., \$1.40 per dwt. ; in dozen lots, \$1.30 per dwt., net.

MADE ONLY BY

LEONARD KROWER, Manufacturing Jeweler

536-538 Canal Street

New Orleans, La.

The Thimble House.



No. 149.

Thimbles are not a side line with us—They are our main business. We study Thimbles, our designers study thimbles, our workmen study thimbles—The result is the finest and largest line of Thimbles on the Market.



No. 136.

KETCHAM & McDOUGALL,

Manufacturers,

37 @ 39 Maiden Lane, New York.

Send for Catalogue.

Established 1832.

ALSO MAKERS OF THE NEW AUTOMATIC EYE-GLASS HOLDERS.

EVERYTHING IN LOCKETS AND CHAINS.

THE BASSETT JEWELRY CO.,

PROVIDENCE, R. I.

Perennially Popular

THE best evidence of the popularity of our various lines is the increasing demand for them and our consequent growth. Our jewelry is unexcelled in every quality that contributes to serviceability and appearance. The designs are artistic enough to court that investigation which results in sales.



No. 1117

Ask to see our line of

CHAINS
CHAIN PENDANTS
CROSSES
AND BRACELETS

The
**Kenilworth
Bracelet**

particularly, the strongest
on the market.

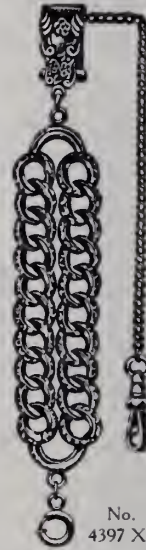

**DORAN,
BAGNALL & CO.**

North Attleboro, Mass.

OFFICES

New York: 194 Broadway.
Chicago: 42 E. Madison St.
San Francisco: 91 Drumm St.

No. 4397 X 1

The "SECURITY" Necklace Clasp

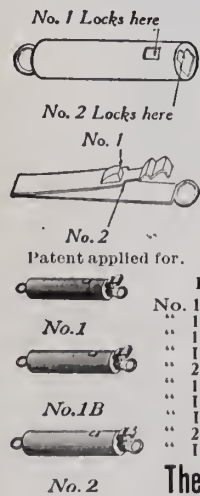

HEAR IT SNAP

Absolutely Secure and Simple. Cannot Pull Out
LOCKS IN TWO PLACES

Making it Doubly Secure

The Only Perfect Clasp

Ask Your Jobber or Write.

PRICES TO THE TRADE:

No. 1.	10-Karat,	\$6.00 doz.
" 1-B.	10 "	7.00 "
" 1.	14 "	7.00 "
" 1-B.	14 "	9.00 "
" 2.	10 "	9.00 "
" 1.	Platinum,	18.00 "
" 1.	Gold Filled,	2.00 "
" 1-B.	" "	2.25 "
" 2	" "	2.50 "
" 1.	Sterling Silver,	2.00 "

The Hoffman Novelty Co., Maker, 79-83 No. Pearl St., ALBANY, N. Y.

"CLINCH"



No. 1, 25c.

Safety Catch for Scarf Pins

Does not mar the pin. Nothing to get out of order. Simple and neat.

One turn to the right grips like a vise.

..FITS ANY SIZE PIN..

PRICES TO THE TRADE

No. 1	Gold Plated	\$1.50 doz.
No. 2	Roman Gold	2.00 doz.
No. 2	14k G'd Pl'te	2.25 doz.

Practical Course in Adjusting

By THEO. GRIDI.

COMPRISING

A review of the laws governing the motion of balance and balance spring in watches & chronometers, and application of the principle deduced therefrom in the correction of variations of rate arising from want of isochronism, change of position and variation of temperature.

ELUCIDATED AND DEMONSTRATED

by original experimental researches in the act problem, never before published, showing causes that are operative in the variation rate, and leading to correct remedies, which have been added chapters on

Published Price, \$2.50.

SPECIAL REDUCED PRICE, \$1.50

Post prepaid.

250 pages, including 18 diagram plates; Full Paper; Large Type; Clear Illustrations; Systematically arranged; Solid Binding.

THE JEWELERS' CIRCULAR PUB. CO.

Publishers

11 John St., cor. Broadway, New York.

WM. SMITH & CO.

OFFICE: Established 1854.

MANUFACTORY:

9-13 Maiden Lane, New York

61 Peck St., Providence, R. I.

Manufacturers of GOLD AND SILVER CHAINS
GOLD, SILVER AND PLATED CHAIN TRIMMINGS

Also GOLD AND SILVER
KEY CHAINS AND
BRACELETS

"IF FOR ANY REASON"

THE LINE THAT QUALITY BUILT

We show the Largest Line of Cameo Fobs Bracelets La Vallieres and Friends on the Market

Our Chain Fob Line is a complete Line in itself. We are always showing New Goods and incidentally selling the up-to-date Jobbers



L. 12041

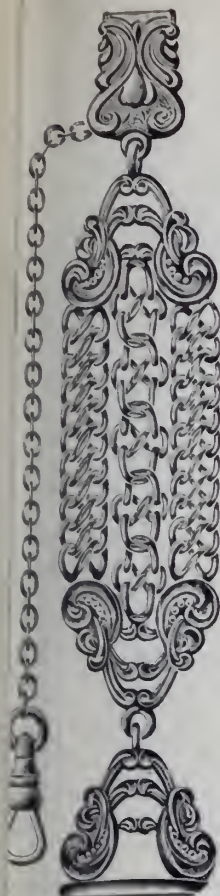

N 134/62

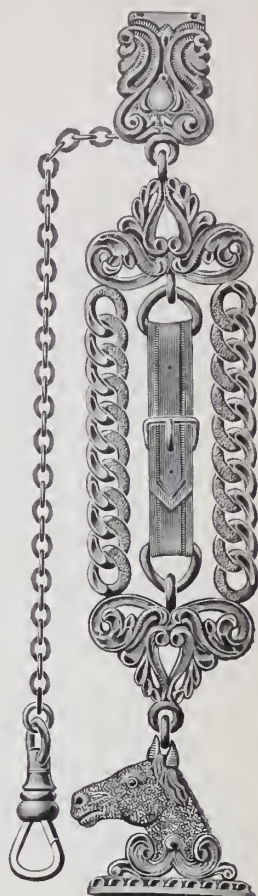

N 104/54

AUSTIN & STONE

INCORPORATED

ATTLEBORO

MASS.



Established 40 Years

Every essential quality of piano construction, tone, touch, scale, design, and beauty of finish are combined in the BRIGGS. They are absolutely and unequivocally a standard piano of the world.

Any SUCCESSFUL JEWELER can largely increase his profits by the sale of pianos, and many receive the greatest part of his income from selling the

"BRIGGS"

We would like to talk this over with reliable concerns in unoccupied territory.

BRIGGS PIANO CO., Boston



Veil, Cuff and Baby Pins

An immense line. Many new designs supplementing our staple patterns—all of acknowledged beauty, and easily sold.

Cameos A revival of an old-style decoration too good to remain in oblivion. Shell, Coral and others, mounted as Brooches, Stick Pins, etc.

Swastika Buckles Bracelets Buttons Charms Brooches Barrettes Combs, Hat Pins, Scarf Pins, Leather Trimmings

MILLER, FULLER & WHITING CO.

Manufacturing Jewelers
New York Office, 9-11 Maiden Lane NORTH ATTLEBORO, MASS.
WE SELL TO THE JOBBING TRADE ONLY





H. J. HOOPER

New York's Leading
Jewelry Auctioneer

Recognized by the Wholesale Houses
the Press and his Patrons

WRITE

him for testimonials that cannot be
equaled by any auctioneer in New York.

Correspondence is strictly between
the principals. Your confidence has
every honorable consideration.

**37 MAIDEN LANE,
NEW YORK CITY.**



HOROLOGICAL DEPARTMENT
BRADLEY POLYTECHNIC INSTITUTE
Formerly Parsons Horological Institute
PEORIA, ILLINOIS

LARGEST AND BEST WATCH SCHOOL IN AMERICA
We teach Watch Work, Jewelry, Engraving,
Clock Work, Optics. Tuition reasonable. Board
and rooms near school at moderate rates.
Send for Catalog of Information

Learn Watchmaking

Refined, profitable labor. Competent men always
in demand. We teach it thoroughly in as many
months as it formerly took years. Does away
with tedious apprenticeship. Money earned while
studying. Positions secured. Easy terms. Send
for catalogue. Address

St. Louis Watchmaking School, St. Louis, Mo



The Gillette Safety Razor Set consists of a triple silver-plated holder and twelve double edged, thin, flexible, wafer-like blades (24 keen edges), packed in a velvet lined leather case. Price, \$5.00. Also made in Combination Sets in a variety of styles with toilet accessories retailing from \$6.50 to \$50.00 each.

Would You Have the Present Year Bring You Increased Patronage, Profit and Prosperity?

Do you realize that nearly every hour in the day some man is converted to the easier, quicker and more economical way of shaving himself with the

Gillette Safety Razor?

Our persistent and vigorous advertising in the leading publications of this country discloses — *and will continue to disclose* — beyond all question of doubt, the superiority of the "Gillette." It advocates the advantages of self-shaving and guides the man to your store with a five dollar bill to exchange for the best shaving device in this world.

You can readily see the wisdom of having the "Gillette" ready when he calls. The Standard Gillette Set retails at \$5.00 everywhere. Combination Sets from \$6.50 to \$50.00. Keep a good supply in stock. Write to-day for valuable selling information and prices.

GILLETTE SALES CO., 904 Times Bldg., New York City



Locket 2985—Old English



Bracelet with Joint
915—O. E., Engraved, Stones set as ordered, 2 3/8"
916— " " " " " " 2 1/2"
917— " " " " " " 2 1/4"



3863—Rose, Red Eyes,
White Mouth
3862—Rose, no stone



3899—Rose,
Red Eyes,
White Mouth
3898—No stone



3842 Rose, set as
ordered
3900 O. E. Set as
ordered

Do You Realize

that Spring is near at hand and with it the certain demand for Good Selling Jewelry?

We offer this Season an exceptional line of Fine Gold Filled Goods, among which are Neck Chains and Pendants, Locket and Charms, Link Buttons and Bracelets, as well as Brooch, Veil, Scarf and Hat Pins.

Each design is skilfully executed and beautifully finished.

Our Sterling Silver Ware includes many new styles in Toilet and Manicure Goods, Vases, Candlesticks and Novelties.

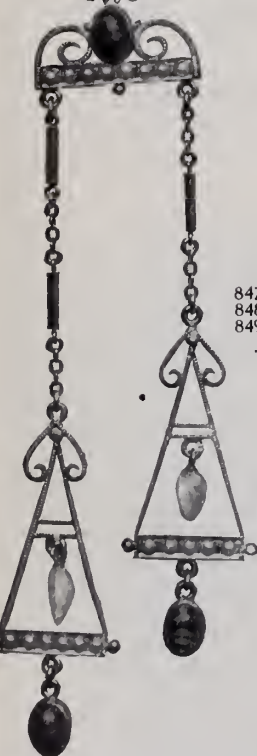

Hat Pin
847—Rom. Red Enam.
848— " Blue
849— " Green "



Belt Buckle
3542—Rose, set as ordered
3543—Green, "
3544—Sterling Grey, set as ordered



851—Rose, Real
Malachite Stone
852—Green, Real
Malachite Stone



844—Rose or
Green Stones set
as ordered



2978—Roman and Green
Pearls and Brilliant
2977—No stone



Baby Pins
3869—Roman
3870—Old English
3871—Pearl Set, Roman
3872—Old English, Pearl Set



3005—Rose, no stone
3007— " Brilliant

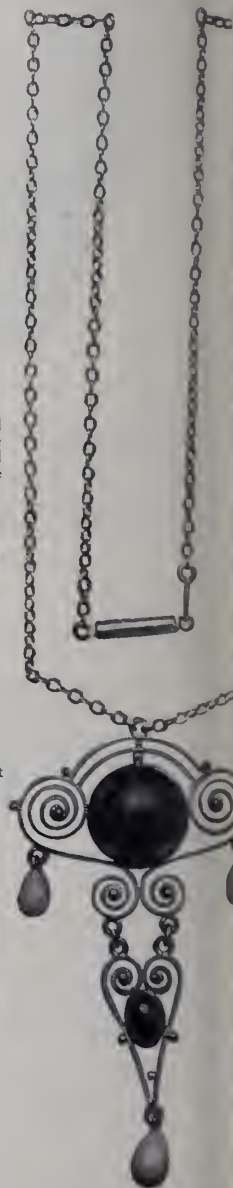

Theodore W. Foster & Bro. Co.

Manufacturing Jewelers and Silversmiths

100 RICHMOND ST., PROVIDENCE, R. I.

NEW YORK 13 Maiden Lane

CHICAGO: Heyworth Bldg.

CANADA: Kingston, Ontario

Neck Chain 294—16" long
Old English Chain
Roman Scrolls
Baroque Pearls and Japanese Jades

No. 298—16" Neck Chain
Roman Scrolls
Jap. Jade Stones, 3 Real O.
Pendants

THE JEWELERS' CIRCULAR

WITH WHICH ARE CONSOLIDATED
THE HOROLOGICAL REVIEW
THE JEWELERS' WEEKLY THE JEWELERS' REVIEW

OL. LVI.

WEDNESDAY, MARCH 4, 1908.

No. 5.

The Designer of Modern Silverware.

By A. F. Saunders, in the *Metal Industry*, New York.

What depends the charm of the composition of the silversmith? asks Charles Blanc, in one of his books. I could answer, it depends throughout on the proportion. Where the silversmith has fulfilled the three following conditions, he has obeyed the fundamental principle, which is the law of his art: His wares should be convenient to handle, well adapted to their use, and as plain as allowable.

Design forms, one of the most interesting as well as important branches of the silverware industry; it is really the trunk out of which grows the finished articles. The designer, while having no set rule to follow, has certain fundamental principles which he must keep in mind, that his wares shall not merely be so-called artistic (a term much misunderstood), but that they shall be well adapted for their use and to the material used in their construction. First of all proportion and practicability should be studied; second, form and a judicious application of ornament. It is always a great temptation to overdo in the matter of decoration, thus spoiling the effect and feeling of refinement of the whole object. The designer to a certain extent allows his imagination to influence him in his creations—that is, he has certain ideals in his mind which are based on what he considers the beautiful, and thus imagines the finished article before him based on these ideals.

He must have a thorough knowledge of the cost of manufacture, the different processes where machine work can be combined with hand work in such a way that it will not decrease the intrinsic value of the work. Of course there is a percentage of his work in which he is given carte blanche; then it is that he can realize some of his ideals and endeavor to make his creation something of beauty and a joy forever. But in this article I am writing of the so-called commercial wares—that is, silverware made on the general trade and in a modern factory where machinery is used when possible.

The first thing the designer does in getting up a design, after settling in his mind the lines he intends working on, is to roughly sketch out on drafting paper the general outline scheme. Take for example a coffee set. After the sizes and outlines of the bodies are settled upon and each piece drawn in the proper proportion to one another, and also a general idea of the decorative scheme considered, the whole design is then gone over and sort of evolved—that is, worked out in detail, adding here, eliminating there, until the whole

combination forms a pleasing, harmonious and artistic creation.

Where his work is placed in competition with others he usually works up his design to the highest degree of finish; sometimes in wash, or pen and ink, making a really beautiful picture. The illustration (shown on the front cover of this issue) of the prize plaque is reproduced from a wash drawing. This piece was designed and made as an international automobile trophy and represents every branch of the silversmith's art (spinning excepted), and is mounted on a mahogany panel.

Again I must refer to his knowledge of the different arts. He must know the material he is working in. A motive suitable for decoration in chased or repoussé work requires an entirely different treatment and feeling when used in etched work. Also the surface to be ornamented must be considered and a certain amount of plain space must be left to form a proper contrast with that which is decorated.

There should be the closest relation between the artist and artisan. While modern shop methods prevent them being one and the same, nevertheless, the results are much nearer the ideal when the two work hand in hand. The so-called arts and crafts movement is doing much in bringing this ideal condition into many up-to-date shops and should receive every encouragement.

While this article is on design, it is necessary to refer to these essential conditions to give a true idea of the designer's work and position. He must also be well versed in the different periods of ornamentation and must be able to feel, to a certain extent, the tastes and influences of the condition of the time of the different styles of ornament that he incorporates in his work. For example, the quiet, classical work of the Greek, the barbarous splendor of the Byzantine and Gothic periods, and the light, capricious character of the courts of the Louis's.

The so-called "art nouveau" movement has given the designer of metal work, as well as his fellow artists and artisans, a chance to deliver himself from the traditional schools of ornament. It has given him a desire to create and beautify and see nature in an entirely different way, using her various moods to express his ideals of beauty in his metal work.

In concluding this article I must say that the designer is offered much more encouragement in his work to-day than he was some years ago, when it was a common expression among the trade that anything went in silver. People's tastes have be-

come more educated in all matters of art, and know the true from the false, in metal work as well as in other art matters. That is the ideal condition the designer strives and hopes for—that his efforts may be appreciated and his wares be objects of beauty to be placed within the reach of all.

The design for an International Automobile Trophy, illustrated on the cover, is the work of the author of the above article, and was made for Geo. W. Shiebler & Co., who were to make the trophy, but it was never completed. The design contains several unique features, being in the form of a wreath of sterling silver 24 by 30 inches, and weighing in all about 230 ounces. The figure of victory in the center is cast in high relief and stands above a perfect model of a racing car.

On either side are the coat of arms of various countries enameled in their proper colors and intertwined is the national flower of each country. A sheet to bear the inscription is hammered out of a sheet of silver and applied as is also the ribbon under the plaque.

The trophy is intended to be mounted on a mahogany panel.

Recent Decisions by General Appraisers as to Duty on Jewelry, Watch Charms and Kindred Lines.

Decisions of the Board of United States General Appraisers, New York, in cases involving duties on jewelry and kindred lines have been announced in the last week as follows:

PINS—JEWELRY.—Protests of Gage Bros. & Co. (Chicago). Pins with metal heads set with imitation precious stones were held to have been properly classified as jewelry. G. A. 6139 (T. D. 26679) followed.

WATCH CHARMS—TOYS.—Protest of Mogi, Momonoi & Co. (New York). The protest related to watch charms classified as jewelry under Par. 434, Tariff Act of 1897. This classification was affirmed as to gold-plated charms; but other charms which had a compass on one face and a watch dial on the other, and which cost less than a half cent apiece, were held dutiable as toys as claimed by the importers.

Jewelers and pawnbrokers have been notified to be on the lookout for several articles of jewelry, valued in all at about \$8,000, which were stolen a short time ago from J. S. Armstrong, 368 Ross Ave., Dallas, Tex. A reward of \$500 has been offered for the capture of the thieves and the recovery of the property. One gold locket, which is among the loot, and which is set with seven or eight diamonds, bears in old English the monogram "M. M. A. F." Another locket, which contains a diamond in the center, bears the monogram "J. A. A." on the back.



No. 3156

Every article of gold jewelry manufactured requires experience, and often clever ingenuity to produce it strong in construction, attractive in pattern and at the right price.

If you have not given our line of 14k. lockets careful consideration you ought to when the opportunity is next presented.

We make a complete line of plain round lockets, the largest line of engine turned lockets in the market and a choice selection of fancy lockets. The above illustration is one from the latter and is made in three sizes, with or without diamonds, for two pictures, at moderate prices.

Our travelers have them, or we will be pleased to send a selection to progressive jewelers.

LARTER & SONS

21-23 Maiden Lane, New York, N. Y.

TRADE-MARK



REGISTERED IN U. S. PATENT OFFICE



No. 278

The making of an article in 14k. gold, then duplicating the same thing in 14k. gold filled, presents two different propositions.

While it is generally known that we make the largest and best line of 14k. gold shirt studs in the world, do you know that we reproduce these same studs in 14k. gold filled, in a great variety of patterns at prices that ought to interest every retail jeweler?

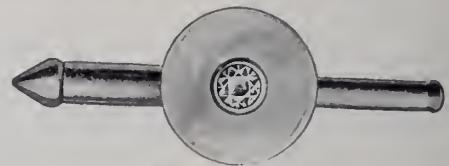

No. 270

These illustrations are from our line of Larter Shirt Studs in 14k. gold filled, and the studs themselves are just as attractive as the pictures.



No. 201

This line is to be had through progressive jobbers only.

LARTER & SONS

21-23 Maiden Lane, New York, N. Y.

TRADE-MARK



REGISTERED IN U. S. PATENT OFFICE

Development in the Art of Jewelry Making

A Paper Read by Mrs. W. S. Hadaway Before the Applied Art Section of the Society of Arts, London
(Continued from issue of Feb. 19.)

Old work, great variety of results were obtained by simple means. In new work, with every kind of complicated means, the results are monotonous. It is from the old that those who are doing good work to-day receive their inspiration, not by repeating like apes the forms and combinations of forms that were once the deliberate expressions of minds which were in harmony with the spirit of their age, but by understanding what has been done, and through his knowledge and obedience to the laws which time has established to develop their own individuality, and by simplicity of method to obtain variety of results, and by voiding those mechanical appliances by the use of which jewelry arrives at such a dead level of commonplace, to produce fresh work of sound execution. There are certain appliances which, of course, it is permissible to use. For instance, if it is desired to repeat a number of small units, such as little five or six petalled flowers like we see in old Hungarian work, or a number of little leaves or devices of any kind, it saves time to have a die cut in steel, and with this to stamp them from the sheet upon the lead-block, and, as repetition is a very valuable factor in design, this saves the laborious process of cutting each leaf by hand from the sheet. The cutting of the die is most important, though, for, as a rule, the professional engraver will give you a very cut-and-dried representation of what you want.

The modern jewelers are so individual that anyone who is familiar with them can pick out at a glance the work of each, and of the pupils influenced by them. Yet, as Mr. Voysey says, we are apt to over-estimate the value of so-called originality without distinguishing between the healthy form of it and that which is mere eccentricity. I do not mean for a moment to say that all those who make jewelry by hand or work independently of trade firms are the authors of good work. There are plenty of misguided ladies who, without training in either design or craft, make so-called ornaments, which they sell to their friends and the uneducated public. Slabs of silver, spread with turquoise blue enamel, or green for variety, with a pearl blister affixed here and there—I have often seen it done with gum or seccotine. This has nothing to do with the art of the jeweler. It ranks with the jewelry of the Rue de Rivoli and the Palais Royal. To wear these ornaments calls for high courage, which is apparently not wanting, and brave souls deck themselves with it heedless of the fact that it is gaudy and deceitful.

Enamel, of course, has its beautiful uses, and in little pieces used with jewels, or little bits of delicate *cloisonné* made with a thin wire (this is very little done, and it is one of the loveliest ways of all to use enamel for jewelry), it is very appropriate.

Little painted enamels, or *champlevé*, are beautiful. Also used to enrich elaborate pieces as in the 15th century Italian. All these ways are fitting and appropriate, but

unbridled indulgence in large surfaces of bright translucent colors is not to be commended. Instead of a restrained mastery over the material, this is a debauch.

The great goldsmiths of the Renaissance were sometimes very sparing in their use of color, subordinating it to the more precious jewels. Simple schemes are often very satisfactory, such as blues and greens on white, white turquoise and green upon coral.

Lewis Day, in his recently published book upon enamel, says: "It seems to be thought that because bright color is to be got in enamel, the brighter the better, and the more of it the more beautiful." I think that little jewel-like pieces of enamel are quite permissible, either in *cloisonné* or *champlevé*, but not a great slab of it. As the quality of transparent enamel is clearness and brightness, it cannot be right not to use the material at its best; that quality should be made the most of, but with discretion. I do not believe in jewels made with enamel on standard silver; the result is mud. For all good results in enamel, fine silver or fine gold is necessary.

There are a number of women who make really good jewelry, and a number who just fall short of being good. As far as the intention, the design and the artistic quality go, all is well, but their hand has not served the apprenticeship long enough to make them mistresses of their implements. Untidily work can never be good. It is not, as some suppose, an artistic quality in a jewel to be sloppy and ill-made. It is in spite of, and not because of, this that many of these jewels are successful. If one can design and originate good jewelry, it is better to employ a competent workman to carry out the scheme under one's own eye than to spoil it with amateur workmanship. To be master of the blow-pipe and chasing hammer takes a long time and much practice.

A short time ago I visited the galleries of the Fine Arts Society. After seeing there some excellent jewelry by Mr. and Mrs. Gaskin, rich with little flowers and leaves of enamel, among which were set jewels of various colors, and the vigorous and sincere jewelry of Mr. Hodel, I came to another room where there was a large case of jewelry by M. Gailliard. The workmanship was more than skilful, the colors were delicate, the materials were good, but after the restrained and simple work of Mr. Hodel and Mr. and Mrs. Gaskin, where the design was nicely adapted to the limitations of the material, it came upon one as a shock—an orgy of delicate realism. There was a daisy made of baroque pearls, which Nature had shaped very like the petals of that flower. There were combs and pendants and various objects copying exactly in both form and color leaves and flowers and insects. If this were all there would be no room for art. Anyone can be trained to make a copy of a flower or insect, or pretty much any object in nature; but nature is not art. It is only when nature is translated

by the artist that it becomes art, not when it is slavishly copied. One would have supposed that this was so well known that there would be no need to say it; but apparently not. I have heard otherwise intelligent people maintain that the more exactly a thing was copied from nature, the better art it was. It is only the individuality of the artist that makes the art worth anything, and if twenty artists were to make a literal copy of, say, a lizard, and if all made it exactly like the model, it would be more a mechanical accomplishment than a work of art; moreover, a result which could be arrived at by casting. For horn and metals to be made to imitate flowers is all wrong. If an image of a flower is to be presented, it must be an image upon which the limitations of the material have been imposed—an abstract of the flower or whatever was intended to suggest the design, the artist's thought about the flower adapted to the material in hand, for no matter how literal an imitation may be, it can in no way compete with the flower as nature presents it.

In ornament, therefore, it is necessary to make use of a severer treatment. In the examples which have come down to us from the earliest times to the present, in no instance has the practice of introducing facsimiles of natural forms been tolerated.

The use of symbols, or a meaning in a jewel, might, I think, easily be carried too far. In the Middle Ages, in the reign of Francis I., devices, as they were called, became so fashionable that almost every personal ornament was made to express a sentiment or meaning of some kind. Sometimes these high-flown and ornate conceits were so elaborate and far-fetched that, instead of conveying a sentiment, they became very puzzling enigmas. In symbolic jewelry, now, I think the mistake might be made of paying more attention to the symbols than to the results as a whole. It is by no means necessary or even desirable that a literary quality should be attached to a necklace or pendant, or ornament of any kind. If in certain instances a sentiment or symbol can be expressed without interfering with what might be called the rhythm of the jewel, no harm is done, but it is quite enough that the jewel should be of good form, good color, well designed and well made throughout.

Speaking of symbolic jewelry, reminds me of a lady, who came to me one day and said she wanted a symbolic jewel. I asked her what she wanted it to symbolize. She didn't know, or care, but she liked interlaced triangles, a serpent or two, and some zodiacal signs. Even painters seem to think that it improves their picture to add a verse of a poem to it. Now, if the picture is satisfactory, it does not need the literary prop. If the picture is weak, the literary prop cannot strengthen it.

I would like to say a word or two about materials. Silver is generally more satisfactory than gold. The yellow of the gold is often too strong for the stones, and it is extremely likely to be too strong for the costume or the complexion of the wearer. Even copper can sometimes be used—it all depends upon the gown and the occasion. Suitability for the occasion is a very important consideration. To be properly

LOUIS KAHN

MOSES KAHN

SAMUEL H. LEVY

L. & M. Kahn & Co.

Importers and Cutters of

DIAMONDS

170 Broadway, cor. Maiden Lane, New York

AMSTERDAM: 2 TULP STRAAT

CUTTING WORKS: 29 GOLD STREET

Arnstein Bros. & Co.

Importers and Cutters of

DIAMONDS

65 Nassau Street

New York

LONDON: Audrey House, Ely Place

AMSTERDAM: 6 Tulp Straat

ALBERT LORSCH.

N. Y. Telephone Call, 2161-2 John.

ALFRED KROWER

ALBERT LORSCH & CO.

LORSCH BUILDING, 37 and 39 MAIDEN LANE, NEW YORK

131 Washington Street, Providence, R. I.

CUTTERS OF
DIAMONDS

quipped every woman needs a variety of jewels, for what suits one gown and occasion is most undesirable for another.

Not long ago I saw a necklace—I forget where it was made—but somewhere there the people are primitive. It was really beautiful in simple design and color. It covered the lady who wore it from neck to waist. The effect with a modern tailor-made gown was most incongruous. It was evidently made for a climate where necklaces are more popular than tailor-made gowns, and there would have been most suitable and lovely. It is in providing ornaments appropriate to all ordinary occasions that the hosts of semi-precious stones are so useful. At moderate cost, as jewels go, one may have a variety of pendants, brooches, necklaces, etc. The range of colors is wide—the green of the chrysoberyl, the blue of the turquoise, the purple and mauves of the amethyst and amethyst quartz, the white and gray and yellow of pearl buttons, the green and pink of the tourmaline, and the shades between them—the one end of the tourmaline crystal being pink and one green—the gray-blue of the blue chalcedony, the delicate pink of the rose quartz, the silvery gray of the moonstone, the mottled orange of the sunstone, the opal-like haliotus shell, the various jacinths and hyacinths and zircons, the yellows of the topaz, the dull red cornelian, the clear rock crystal, the curious gray and blue shot abrasadorite, corals, lapis lazuli, the innumerable shades and varieties of Mexican opal, and the matrix of this, and, most beautiful of all, the opal and opal matrix—this bewilderingly lovely stone, made of tiny specks of every color, juxtaposed in such a changing variety that a counterfeit is not possible. The diamond may be counterfeited, but not the opal; it defies imitation. There is an unfortunate and quite unfounded prejudice against this stone. Sir Walter Scott was largely responsible for this in his novel, "Anne of Geierstein," though another superstition dates back to the seventeenth century, when, at the time of the plague in Venice, an observant person noticed on one of the victims an opal which grew milky and lost its brilliancy. In reality it is probably a survival of the superstitions of the Middle Ages, when all sorts of powers were ascribed to precious stones. The pharmacopœia of the time contained many a sovereign remedy made of powdered gems, and to every gem was ascribed a virtue. The diamond alone was considered poisonous if administered in powder.

There is much difference of opinion about the diamond now; some artists refuse to make use of it at all. I can see no reason why the diamond, used properly, should not be beautiful, particularly with colored stones. As it is now worn it is simply an outward and visible sign of the wearer's wealth, or at least of credit with the jeweler. There is a sort of reason, too, for these glittering masses. At large functions, the opera, large receptions, and so on, but for plenty of glittering stones the jewelry worn would not be noticeable at all. If much glitter is the desired aim the more quiet jewels of beautiful design would not answer; but after all limelight and spangles supply more glitter than all the diamonds put together, so, as it is impossible to vie

with sham glitter, surely more quiet jewels which depend upon the art of their making for their charm are more desirable.

Of course, everyone has his own method of working. I do not think that from designs first drawn on paper, and then carried out by the workman, that the best result can be arrived at. The more spontaneous way is to have at hand the grains, the wires, the twist wires and bead wires of various sizes, various little devices made with these and with the stones and materials to arrange the pattern as one goes along, handing it to the workman to be soldered and finished, or after having made the pattern in this way, to make the sketch, and hand this with the pieces to the workman, unless it is all to be done with one's own hands, and time hardly allows for this if one has to design and make everything. To people who work in this way it is disconcerting to be asked for designs, for as the stones, or pieces of enamel, or devices at hand suggest the designs, it is working backward to make the drawing first.

There is not much literature of artistic jewelry in English. I should like to recommend Mr. Wilson's book, Nelson Dawson's (recently published), also Mrs. Nelson Dawson's book on enameling, Mr. Day's recently published book on the same subject, which deals with it from the historical, while Henry Cunyngame's deals with it from the technical side. This book has been of the greatest service to those who wish to understand the processes of enameling; many people have learned the art from it alone. Then there is Cyril Davenport's small book on jewelry in the same series as Mrs. Nelson Dawson's on enamels. Mr. Fisher has also written a short account of enameling, more theoretic than practical. No better treatise on the art of jewelry has been written than the one which the monk, Theophilus, who lived in the 11th century, has left behind him. These old monks worked under ideal conditions, without haste, and without worldly cares. But for them the arts would have fared badly in times when countries were turbulent with wars, and outside the monasteries there was too little tranquility for their practice.

Some make the mistake of thinking that the more elaborate the design the better it is. Now the simplest arrangement may be infinitely better than the most elaborate. It all depends upon the result, and the over-elaborate is more likely to be wrong somewhere. Sometimes, indeed, what would be quite good and satisfactory is spoiled by over-elaboration. Well-wrought simplicity is admirable; for instance, the Italian peasant's jewelry. It is not necessary for all the little fishes to try to look like whales. Without a proper sense of fitness and a feeling for good design, no jeweler can produce good work. A fine sense of discrimination is necessary, so that among the many historic styles, and the hybrids of these, one may not come to grief. There are just as many *bad* old styles as there are good—rather more, perhaps—and to blindly copy an old style because it has survived is not likely to lead to good results. Some of the very best and most sincere and simple of the old work has been lost, for, unlike a picture or statue, the precious metals could be melted into ingots of value, and the

jewels removed and sold. Every piece of work by the famous artisan bishop of the seventh century, St. Eloi, has been lost. This patron saint of jewelers executed many important works for churches under the patronage of Dagobert I., among them the shrine of St. Geneviève and St. Germain; also jewels for personal use. His own garments were thickly embroidered with gold and gems. He wore a golden girdle set with precious stones, his gowns were of fine linen embroidered with gold, and the border of his silken sagum was likewise adorned. This was at a time when, of course, all the courtiers of the Frankish king were clothed in the richest manner. They were passionately fond of costly dresses and jewels and even jeweled weapons. Scarcely any examples of the goldsmiths' work of the first centuries of the Middle Ages remain. These would, if we had them, be a rich source of inspiration.

It is entirely a modern mistake to separate the art of the jeweler from other arts. At the end of the 14th century, two great artists came from the workshop of a goldsmith, Fillippo Brunelleschi, and Luca della Robbia. Ghiberti never renounced his original profession, but continued during his whole life to execute works connected with the goldsmiths' art.

Benvenuto Cellini, who stands at the very head of the goldsmiths of his time, and who brought the art of chasing to a greater perfection than had been known before, was—as well as goldsmith—sculptor, artist, author, and, according to his own tale, warrior and braggart as well.

Verrocchio, whose statue of Bartolomeo Colleoni at Venice is said to be the finest equestrian statue in the world, was first a goldsmith; Ghirlandajo; and Francesco Francia; in fact, all the goldsmiths of this wonderful period, the 15th century, were either painters or sculptors, or both, as well.

The art of the goldsmith was considered an art; now it is a trade, and while the public who buy are contented with the products turned out by the trade, the artists will have to be satisfied with less commercial success perhaps than falls to the more unworthy product. About 20 years ago, a commercial house made an effort to elevate the public taste in jewelry. They employed some of the best known artists of the time, and spent considerable sums on it, but the result was a dead failure, and they were obliged to fall back upon the old lines as regulated by the law of supply and demand. I have no means of knowing what the result of these experiments were, but it would seem that when commercialism comes in at the door, art flies out at the window. The Guild system has been suggested as a remedy that each person working at jewelry or any other craft should be examined by masters, and granted a certificate before they might practice it, but this would not prevent commercial houses springing up outside the Guild, and competing with it.

I am sure it must be impossible to try to apply to one age the conditions which fitted another. We have to cope with present conditions. It is not possible now to hold together a Guild, which could exclude from practice all but the capable. The Guild, except as a species of aristocracy of craftsmen, is a thing of the past.

EDUARD VAN DAM

CUTTER OF

DIAMONDS

— CUTTING SHOPS: —

ANTWERP

41 Rue de la Province (Sud.)

CABLE ADDRESS, MADNAV

NEW YORK

437-439 Fifth Ave.
Cor. 39th St. Knabe Bldg.

TELEPHONE, 5879 38TH ST.
CABLE ADDRESS, DEVRIVAN

AMSTERDAM

55 Ruysdaelstraat

CABLE ADDRESS, MADNAV

LONDON OFFICE, 22 Holborn Viaduct

AMSTERDAM

2 Tulpstraat

LONDON

40 Holborn Viaduct

OPPENHEIMER BROS. & VEITH.

CUTTERS OF DIAMONDS.

Cutting Works
43-45-47 John Street

NEW YORK
65 Nassau Street

R., L. & M. FRIEDLANDER

IMPORTERS OF

DIAMONDS

30 MAIDEN LANE, - - - NEW YORK CITY

MEYEROWITZ BROS.

IMPORTERS OF

DIAMONDS

PRECIOUS and
SEMI-PRECIOUS STONES

ESTABLISHED 1896

NEW YORK: 37-39 Maiden Lane
PARIS: 58 rue de Maubeuge
AMSTERDAM: 2 Tulpstraat

MEYEROWITZ BROS

MEYEROWITZ BROS

REIGNING PARIS FASHIONS.

JEWELRY NOVELTIES SEEN IN FRANCE'S CAPITAL

IN France the designing of jewelry is classed among the fine arts, and in no other country does one see such excellent examples of the goldsmith's prowess. It is not an accidental profession, but is acquired in the school of Arts et Metiers and looked upon as seriously as sculpture or painting. Again, it is not always taken up as a trade, but as a heritage, for some of the Parisian jewelers, or at least their ancestors, have been in the business for hundreds of years, and look upon it as a proud calling. The French realize the value of settings as no other nation does, and often assign significant stones are so exquisitely set as to be more attractive than some enormous gem that owes its beauty alone to its flawless quality and size. The artisan has a number of advantages over his American confrère, for the Louvre and other museums contain treasure unknown in a younger country. There are fine examples of gold and silversmithing dating back to the Merovingian kings and to the medieval period when gold and precious metals were wisely employed not only for the adornment of the person, but for household utensils, furniture and bric-à-brac.

Just now the necklace is in high favor, and the variety stuns the imagination. Some of them are archaic in their simplicity, while others are of delicate and elaborate workmanship. Of Egyptian origin are pendants in triangular, lozenge and square shapes and with simple and rather barbaric setting, great turquoise matrix, cabochon amethysts and jade imbedded in lustrous ruddy gold, the patterns reproduced from the jewels found on long buried nunny queens, the sole reminder of whose greatness was these inanimate things of metal, enamel and uncut stones. Others bear evidence of being the replicas of necklaces discovered in the ashes of Herculaneum and Pompeii; they are in the more delicate workmanship of a classic age. Here is a network of fine chains from which are suspended a precious wrought intaglio, a cameo or one of enamel so lovely in coloring that the original can scarcely be distinguished from the reproduction, so perfect is the similitude. Mythological subjects or the heads and busts of famous Greek warriors are general, the carved amethysts, topaz and carnelian furnishing an admirable background for the engraver's tools.

Topaz and amethyst are much used in the jewelry of the present day. Some of the necklaces show a string of faceted amethysts imbedded so that only a narrow rim of dead gold is apparent, while the great heavy stones are set so as to form an ornamental pendant. However, light effects are paramount, small stones incrusting so as to form a floral pattern or surrounding diamond or colored gems. Very artistic are pendants square or oval in an open work pattern of tiny stones. A great square amethyst dangles from a big diamond surrounded by pearls and connected by airy loops and ropes of diamonds with invisible settings.

A cross hangs from a slender silver chain and is of unique design. The cross,

about two and a half inches long, is thickly set with small diamonds, while in the center is a smaller cross of pale pink topaz. Pearls are often associated with diamonds or colored stones, pear-shaped pearls swinging from delicate gem-incrusted chains or those of chain links in colored gold.

There is a fancy for straight and narrow strings of rubies or emeralds at least a finger in length, from which depend long pear-shaped pearls or ones in the fashionable rose, quartz or pale green jade.

Necklaces of serpents in Etruscan gold, vari-colored gold or of aluminum and gold in combination are much in favor. The elastic scaled reptile is twined about the throat of beauty, its bejeweled head resting lovingly upon the white neck of the wearer. Some women carry the cult of the serpent to an absurd extent, and wear a bejeweled bracelet to match the coils reaching almost from wrist to elbow. Others also don a serpent ring, but this is carrying matters a little too far.

Bracelets are greatly worn, the fashion of the short sleeve—which is, however, on the wane—necessitating some adornment of the arms. Extensible bracelets adjusted by means of springs are used to keep the top of the glove in place; they are rather narrow, consisting of gold links set with precious stones. Others show oblong pieces of pierced gold alternating with squares of colored stones rimmed with tiny pearls or diamonds. Quaint is a bracelet in a pattern of pine needles in greenish gold with cones of coppery color between square pieces of repoussé gold. Attractive is a bracelet in a lattice work design formed of small rubies and diamonds. Bracelets showing pink and green in oval cabochons are linked together with rather heavy chains.

Brooches are much worn, the fashionable neckwear necessitating such a finish. A ribbon or silk cravat about an inch and a half wide is crossed beneath the collar and fastens with a fancy brooch, or scarf pin. Quaint brooches are of reddish shaded gold in the form of a dragon or other impossible animal, a great ruby or diamond being set in the head. The eagle, the dove and the swallow are among the favorite pins. Rather pretty is a bird's nest of finely interwoven gold wire upon which broods a white pigeon formed of a baroque pearl or white enamel. Butterfly and floral pins are always liked.

There is a growing fancy for turquoise, which is utilized in a number of ornaments, usually enhanced with diamonds which seem to intensify its color. Hat pins, very large, are of cream-colored enamel with dark stains on the edge, and in airy lace-like patterns, the center consisting of a big turquoise matrix or cabochon amethyst. Bracelets of the same fashion are attractive.

Small chain purses are elegant and expensive little trifles. One was in stripes of vari-colored gold and aluminum; another showed a design of oblong spots in red gold on a dull yellow ground, while still another was made of a golden network threaded with the tiniest of precious stones. The clasps were superb, scintillant with gems and fine gold work.

The only jewels worn in daylight are

necklaces, bracelets and pins made of semi-precious stones, the fine stones being reserved for evening wear.

Blouse sets of colored enamel, the buttons as big as a dime are liked. They are intended only for the open front blouse and are not proper for the back. Pins as long as the finger and as narrow as possible are imbedded with square-cut gems and are intended to confine scarfs, fur boas, etc. A quaint brooch shows a very tiny mirror framed in gold; upon the surface crawls a golden fly.

Little gilded boxes in fluted shell shape contain a very small mirror, a powder puff and half a dozen pearl-headed pins.

COUNTESS DE MONTAIGU.

Interesting Lecture on Jewelry Design Delivered by C. Howard Walker at Providence.

PROVIDENCE, R. I., Feb. 26.—“Jewelry Design” was the theme of an interesting discourse which C. Howard Walker, of Boston, delivered last week before the meeting of the Alumni Association of the Rhode Island School of Design. The meeting was attended by craftsmen and persons who are interested in the design of jewelry and silverware.

Mr. Walker, in opening, explained that jewelry is essentially an article of adornment for women, and that the word itself is derived from the same root as the word joy. He divided jewelry into two classes, that which may be worn at a high social function and that appropriate for ordinary wear. The ability of a woman to discriminate as to the fitness of her ornaments to the various gowns she wears, he said, distinguishes the refined woman from the Congo female or Hottentot who essay gaudy objects in their barbaric taste.

Going into the subject of various articles of jewelry, Mr. Walker took up the chief elements of necklaces and paid particular attention to the development of chains which form an important part in connecting the integral parts of necklaces.

“The style of links,” he said, “is especially noteworthy, being of two kinds, the geometric link and the cage link, with a possibility of infinite variety in type and combination.”

Taking up the work of the Greeks he described at length their beautiful delicate gold ornaments; the early Roman and Etruscan jewelry, which was made on much bolder and plainer lines when the variety did not consist in grouping but in alternation; the Byzantine type with its wealth of jewels and gold settings, and the Renaissance type with its striking resemblance to the lace designs of the 15th and 16th century jewelry.

“Sensation and novelty,” said Mr. Walker, “are not an element of virtue and some of the modern work forces the note to absurdity. Jewelry depends on quality not quantity, or its distinction and an unintelligent type of design is characteristic of *l'art nouveau*.”

W. W. Thurlow, for a number of years a retail jeweler at Newburyport, Mass., has sold his store and taken a position as traveling representative.

REGISTERED



TRADE-MARK

RINGS

REGISTERED



TRADE-MARK

RINGS are always in demand, and are always salable, provided you have the right kind to sell. We have—

RINGS of every description: signet rings, diamond rings, fancy rings, rings of every style and combination of stones.

RINGS that satisfy the most critical and appeal to every taste and fancy.

RINGS You can sell. *Write us or wire us any time. We are always ready for your order.*

HAYDEN W. WHEELER & CO., Importers

AMSTERDAM, 2 Tulp Straat

2 Maiden Lane, NEW YORK, N. Y.
Phone, 7365 Cortlandt

LONDON, 50 Holborn Viaduct

ORDER

DIAMONDS

ON MEMORANDUM FROM

ALFRED H. SMITH & CO.

London,
8 Holborn Viaduct.170 BROADWAY, NEW YORK
Corner Maiden Lane.
Also 475 FIFTH AVENUEChicago,
103 State Street.

F. A. JEANNE

Cat's= Eyes

5 Square de l'Opera

PARIS, FRANCE

Cable Address

" GEMFINDER "

Western Union Code

Gems and Precious Stones

—
Cloth, Postpaid, \$1.00
—

Published by

The Jewelers' Circular Pub. Co.
11 John Street NEW YORK

RUDOLPH NOEL

PHILIP NOEL

RUDOLPH NOEL & CO.

IMPORTERS AND CUTTERS OF DIAMONDS

2 Tulp Straat, AMSTERDAM

37-39 Maiden Lane, NEW YORK

Increase in Thefts at Jewelry Factories of the Attleboros Said to Have Followed Decreased Operations.

ATTLEBORO, Mass., Feb. 27.—Within the last few weeks, when curtailment has been the rule in a number of the jewelry factories, a new and decidedly serious problem has arisen in the form of increased larceny of precious metal and finished stock by unscrupulous employes, seeking in that way to keep their incomes up to the standard of good times. "If the manufacturing jewelers should see all that was taken from all the factories in the past month piled in a heap they would die of heart failure," said one of the leading police officials Saturday.

It is not that the standard of morals is any lower now than in the past. There was always an element in the factories, as there would be in the same number of people in any walk of life, who have to be watched, to be kept in check by systems and schemes to prevent pilfering. While business was flourishing, their time was fully occupied, and wages ran high, the temptation to these weaker boys and men was reduced. Now, with enforced partial idleness and reduced incomes they find themselves facing the old temptations in stronger form.

Every factory has its system for checking up the arrival, movements and departure of every grain of precious metal. These systems are as rigid as they can be made, but so long as they are applied by human agents there will be defects, and men and boys bright enough to take advantage of the defects, if not to create them themselves. In one very recent case a confession was secured by police from a lad which did not reach the press and public. They discovered that in one of the large silver shops this boy, several years under 20, had periods in the day when he was entrusted with silver spoons, nearly at a complete state. In a manner calling for little or no trouble he was able to change the checking system, and throw one or two of these spoons in a lump-can. In some cases he blackened them with a flame before so doing. His scheme then was to take along an innocent comrade as a witness, and have the latter see him "find" the spoons in the can. The plan's very simplicity was its strongest point and it had been successfully operated more than once when a police officer investigating the loss of metal suspected this very arrangement, and forced a full confession.

In a shop where a varied line of jewelry is made a young man was recently suspected of taking finished articles, and various traps set to catch him failed. At last the simple expedient of a marked locket left in his way turned the trick. The locket was found in his dinner-box at 6 when he was leaving the shop. In a third case a young man, part of whose work was melting precious metal, fell into the habit of steadily palming small bits, and taking them away in his pocket, this being done so ingeniously that even men set to watch him every minute of the day failed to catch him. An officer's vigilance produced better results and restitution.

At a meeting of manufacturers, who ran together by chance in a clubroom a few days ago, the matter was earnestly discussed, and the suggestion made that in

some shops it would be desirable to have the precious metal handled by a few, willing to submit to search on their departure. It is doubtful, however, if this method will be adopted, owing to the opposition it would certainly encounter.

Jeweler Elected King of Carnival at Mobile, Ala., Mardi Gras.

MOBILE, Ala., Feb. 27.—An interesting feature of the Mobile Mardi Gras this year to the jewelry trade lies in the fact that a local jeweler, Troost Parker, of the firm of Parker Bros., will be the King of the Carnival. This is considered quite an honor as the king is chosen by representatives of the business and social clubs of the city and the honor comes entirely unsolicited. This



TROOST PARKER, KING OF MOBILE'S MARDI GRAS CARNIVAL.

is the first time a member of the jewelry trade has been so honored in this city or in New Orleans.

Mr. Parker is very prominent in society and is a member of the Athelston Club. He is a member of one of the oldest families of Mobile and is a son of Major Frank S. Parker, C. S. A., and nephew of James Battle, the original owner and builder of the Battle House.

Death of John C. Schaefer.

PITTSBURG, Pa., Feb. 27.—John C. Schaefer, at one time a well known jeweler of Pittsburg, died Saturday night at his home Center Ave. and Craig St., aged 57 years.

Mr. Schaefer started in the jewelry business for himself 21 years ago, opening a store in Wylie Ave. Later he moved to Fifth Ave., where he conducted a store for a number of years. During the later years of his life, however, he had been employed by jewelers and worked for the George B. Barrett Co. for a time. He had been a resident of the 14th ward of this city for 21 years and was well known to all the jewelers of this section. He is survived by his widow and four sons—Joseph, Charles, John N. and Harry W. Schaefer—who re-

side at home, and two daughters, Miss Lillian Schaefer at home and Mrs. Austin L. Bailey, of Oakland.

The funeral services were held from the family residence last Tuesday afternoon at 2:30 o'clock and a large number of jewelers attended. The interment was private.

Jewelry, Clocks, Watches, Silverware and Kindred Lines Exported from New York.

WASHINGTON, D. C., Feb. 26.—The following were the exports of jewelry, silverware, optical goods, clocks, watches and kindred lines exported from New York for the week just ended:

- Antofagasta: 2 cases of watches, \$910.
- Barbados: 5 cases clocks, \$1,000.
- Bangkok: 3 cases optical goods, \$510; 8 cases clocks.
- Berlin: 27 cases clocks, \$1,454.
- Bristol: 1 package optical goods, \$227.
- Bremen: 1 case plated ware, \$115; 2 cases watches, \$4,394; 1 case jewelry, \$125.
- Buenos Ayres: 2 cases optical goods, \$2,933; 1 case plated ware, \$196; 1 case watches, \$354; 78 cases clocks, \$1,701.
- Bombay: 55 cases clocks, \$1,283.
- Calcutta: 68 cases clocks, \$1,380; 1 case watches, \$155.
- Christiania: 7 cases clocks, \$444.
- Curacao: 1 case watches, \$120.
- Colon: 2 cases silverware, \$236.
- Corinto: 1 case plated ware, \$115.
- Ecuador: 1 case jewelry, \$120.
- Frankfort: 1 case clocks, \$200.
- Guayaquil: 3 cases clocks, \$198.
- Geneva: 2 cases jewelry, \$500.
- Hamburg: 2 cases plated ware, \$245; 4 cases optical goods, \$846; 18 cases clocks, \$858; 1 case watches, \$175; 5 cases optical goods, \$13.55.
- Havre: 4 cases watches, \$6,027; 2 cases jewelry, \$359; 3 cases optical goods, \$1,184.
- Hongkong: 43 cases clocks, \$727.
- Havana: 19 cases clocks, \$258; 2 cases optical goods, \$476; 19 cases clocks, \$258; 2 cases optical goods, \$476; 1 case optical goods, \$239; 2 cases clocks, \$1,000; 1 case jewelry, \$606.
- Kobe, Japan: 59 cases clocks, \$2,217.
- Lisbon: 7 cases clocks, \$165.
- Rome: 1 case jewelry, \$150.
- Liverpool: 1 case watches, \$150; 1 case jewelry, \$350; 7 cases watches, \$1,325; 1 case optical goods, \$426; 3 cases jewelry, \$634; 1 case jewelry, \$190; 170 cases clocks, \$2,778.
- London: 47 cases clocks, \$1,588; 15 cases watches, \$1,896; 3 cases scopes and views, \$177; 1 case jewelry, \$120; 10 cases optical goods, \$2,916; 20 cases plated ware, \$615; 123 cases clocks, \$3,426; 3 cases watches, \$186; 1 case watch cases, \$350; 71 cases clocks, \$1,976; 90 cases clocks, \$6,115.
- Manila: 2 cases silverware, \$406; 2 cases silverware, \$406; 12 cases clocks, \$160; 2 cases silverware, \$1,600.
- Madras: 42 cases clocks, \$628.
- Melbourne: 2 cases optical goods, \$490; 228 cases clocks, \$5,052; 23 cases plated ware, \$1,030; 1 case scopes and views, \$300.
- Naples: 3 cases jewelry, \$350; 4 cases clocks, \$150.
- Nassau: 2 cases jewelry, \$197.
- Paramaribo: 1 case watches, \$120.
- Peru: 4 cases clocks, \$108.
- Rio de Janeiro: 17 cases clocks, \$270; 169 cases watches, \$14,728; 45 cases clocks, \$1,578; 5 cases watches, \$1,088.
- Santiago: 6 cases clocks, \$109.
- Shanghai: 68 cases clocks, \$968.
- Singapore: 2 cases watches, \$348; 1 case silverware, \$634; 16 cases clocks, \$388; 3 cases optical goods, \$338.
- Southampton: 2 cases stereoscopes, \$226; 6 cases clocks, \$204; 10 cases watches, \$1,894; 7 cases stereoscopes, \$1,316; 23 cases watches, \$13,087; 7 cases optical goods, \$222.
- Sobrabaya: 2 cases plated ware, \$120.
- Valparaiso: 18 cases clocks, \$266.
- Vera Cruz: 16 cases jewelry, \$373.

The Michigan Optical Co., Detroit, Mich., has increased its capital stock from \$85,000 to \$120,000.

Not One Stone

has ever come near attaining the popularity of the Reconstructed Ruby—the Hope Sapphire following next. * * * Comparatively inexpensive, these two Gems are within the reach of all, their demand increasing rapidly with their introduction to the general public.

* * * We have realized that these Scientific Gems are articles that have come to stay, and have accordingly equipped ourselves for their uninterrupted production. Our facilities for cutting these stones enable us to fill all possible orders without delay.

L. Heller & Son

Importers of Precious and Imitation Stones
68 NASSAU STREET, NEW YORK

PARIS
39 Rue de Chateaudun

PROVIDENCE
212 Union Street

IDAR
14 Hauptstrasse

STERN BROS. & CO.,

CUTTERS OF

DIAMONDS,

CUTTING WORKS:

138-142 West 14th St., N. Y.

68 Nassau St.,
NEW YORK.

CHICAGO,
103 State Street.

LONDON,
29 Ely Place.

HIRSH & HYMAN,

IMPORTERS AND CUTTERS OF



2 MAIDEN LANE, NEW YORK

Broadway-Maiden Lane Building

ESTABLISHED
1872.

E. HAHN & CO.,

33, HATTON GARDEN, 33
LONDON.

CABLE ADDRESS:
"AGUAMARINE," LONDON.

- | | | |
|--|---|--|
| Precious Stones, Semi-Precious Stones,
Ceylon Fancy Stones, Pearls, Corals, Opals
and All Novelties in Stones suitable for | } | I. All Jewelry and Export Purposes. |
| | | II. Art Metal Work, Church Work. |
| | | III. Mechanical Purposes. |
| | | IV. Collectors, Educational Purposes, Museums. |

TURQUOISE

Matrix - Turquoise

Best the World Produces

WE ARE prepared to furnish
to the trade Matrix-Turquoise
in all shapes and sizes.

Exquisite Color
and Markings

We cut Turquoise to order

Mines at Mojave County, Arizona

THE ARIZONA
TURQUOISE MINES CO., Inc.

Cutting Works and Sales Office
171 Broadway, New York

SEND FOR CATALOG

Telephone 5728 Cortlandt

Silver Plate Containing Push Button With Which President Roosevelt Started First Train Under Hudson River.

As has often been said, there are a few events of civic or political importance that have occurred in recent years in which the jewelry trade has not been called upon to participate by producing some work in gold or silver that has some connection with the event. The opening of a tunnel under the Hudson River and

which the President pressed was on a silver plate made by Tiffany & Co., New York, an illustration of which appears herewith. As will be seen from the cut, the button is set in a frame, the decoration of which appropriately suggests the tunneling of the river. The button itself is surrounded by a wreath, above which are three shields. It bears the following inscription:

"At the White House in Washington, with this push button, President Roosevelt

Minneapolis Jewelers File Complaint Against Many Railroads, Alleging Unjust Discrimination in Freight on Bullion Sweepings.

WASHINGTON, D. C., Feb. 28.—Rentz Bros., Minneapolis, Minn., have filed a complaint with the Interstate Commerce Commission against the following railroad companies: Chicago, Burlington & Quincy Railroad, Chicago Great Western Railroad, Chicago, Milwaukee & St. Paul Railway, Chicago, Rock Island & Pacific Railway, Great Northern Railway, Illinois, Iowa & Minnesota Railway, Minneapolis & St. Louis Railway, Minneapolis, St. Paul & Sault Ste. Marie Railway; Chicago, St. Paul, Minneapolis & Omaha Railway, Wisconsin Central Railway. Rentz Bros. are manufacturing jewelers, silversmiths, dealers in bullion, and shippers of bullion sweepings, at 519, 521 and 523 First Ave., S., Minneapolis. The defendants are railways engaged in the transportation of persons and property between points in the State of Minnesota and points in the State of Rhode Island.

It is claimed by Rentz Bros. that they have at different times made reasonable request upon the defendants to furnish and provide for them facilities for the transportation of bullion sweepings between points in the State of Minnesota and points in the State of Rhode Island, and that the defendants have refused to accept from them for transportation such bullion sweepings, which is contrary to the provisions of the act to regulate commerce, to which they should be subject; that they have refused to furnish and provide proper facilities and that they have refused to furnish, establish or provide a just and reasonable rate for the transportation of these bullion sweepings, and also that they have refused to furnish a through route between the two places on the bullion sweepings, and that they have furnished transportation and through routes for other property which has a higher value and greater hazard to the transportation companies than have the bullion sweepings, the average value of which is about \$60 per barrel, and that it is shipped enclosed in water-tight oak barrels. For instance, they carry gold and silver plated ware, marble and bronze statuary, clocks, nickel plate watch cases, watch crystals, cutlery, etc. This is said to show a discrimination and a violation of section 1 of the act to regulate commerce.

It is claimed that the roads are practising a discrimination in subjecting the shippers of bullion sweepings to an unusual and unjust disadvantage, and that the refusal to make a tariff rate is a discrimination against them and to other shippers of bullion sweepings and is in direct violation of the law.

They ask that the defendant roads be required to desist from such discrimination, unreasonable prejudice and practices, and that they be required to furnish and provide reasonable and proper facilities for the receipt and shipment of these bullion sweepings, and to establish a through route and a reasonable rate for and on same.

T. W. Warren, Lewistown, Mont., is selling out at auction. He also has a store in Hawlawton.



SILVER PLATE CONTAINING PUSH BUTTON WITH WHICH PRESIDENT ROOSEVELT STARTED THE FIRST TRAIN UNDERNEATH THE HUDSON RIVER.

the starting of the first train on the railroad from New York to New Jersey, Feb. 25, which is considered a most important event for both States, was no exception to the rule as it was the occasion for the production of a silver plate that will long be looked upon with interest by the people of this country.

It should be mentioned that the first train to go through the tunnel was started by a signal given by President Roosevelt, who pressed a button in the White House in Washington, which caused the first train wheels to begin to turn. The push button

gave the signal which started the first train of the Hudson and Manhattan Railroad Co. through the tunnels in the Hudson River between Sixth Ave. and 19th St., New York, and Hoboken, N. J., Feb. 25, 1908."

Oliver Willson, Winfield, Ia., has sold his stock to R. H. Ferris, who will take possession March 1.

E. B. Woodward, Bismarck, N. Dak., has installed in his store two new golden oak wall cases which add considerably to the establishment's attractive appearance.

Chester Billings & Son

1840

Successors to
Kandel, Barmore & Billings

1908

Importers of Diamonds
Other Precious Stones, and
Pearls, Diamond Jewelry

1840, Kandel & Barmore; 1866, Kandel, Barmore & Co.; 1880, Kandel, Barmore & Billings; 1897, Chester Billings & Son

New York, 58 Nassau Street, 29 Maiden Lane
London: 22 Holborn Viaduct, E. C. Paris: 53 Rue de Chateaudun
Amsterdam: 2 Tulp Straat

GEORGE H. HODENPYL.

WALTER N. WALKER.

HODENPYL & WALKER

IMPORTERS OF

DIAMONDS

OTHER PRECIOUS STONES
AND PEARLSMANUFACTURERS OF
FINE DIAMOND JEWELRY

373 FIFTH AVENUE, NEW YORK

Corner 35th Street

Telephone, 5093 Madison Square

CHAS. F. WOOD & CO. DIAMONDS

MAIDEN LANE

NEW YORK

EISENMANN BROS.

IMPORTERS OF

Pearls and Precious Stones

452 Fifth Avenue, New York
cor. 40th St., Knox Building

3 Rue St. Georges, Paris.

CENTENNIAL TIMERS



Without question the best plain and split second timers made.

Register with scientific precision. Substantially built and mechanically perfect.

Invaluable for athletic, mechanical and scientific observations. Cased in nickel. Much in demand during the racing season.

We also carry split chronographs with minute registers, cased in gold, gold filled and sterling silver.

All makes of American cases and movements.



Cross & Beguelin

31 Maiden Lane, N. Y.

Established
1863Telephone
480 John

Examination in Bankruptcy of Jos. Brown & Co., Chicago, Still Going on.

CHICAGO, Feb. 29.—Two sessions in the examinations into the affairs of Jos. Brown & Co. were held last week. Jacob Ringer was absent at the first session, but Israel Shrimski took up the line of examination. Waldeck, assistant cashier of the Continental National Bank, testified that Brown hid certain immatured notes of his own solution. Brown previously testified he was obliged to square up with the bank. Mr. Waldeck said Brown made a signed statement to them on April 30, which purported to have been compiled Jan. 2, 1907. This statement showed assets as: Cash on hand, \$30; cash in bank, \$1,197; bills receivable, \$77; accounts receivable, \$94,730; merchandise, \$110,300; memos, \$3,800; total, \$210,488. Liabilities: Bills payable, \$30,215; due on open account, \$80,000; capital, \$75,000; surplus, \$25,000. S. M. Jess had previously testified that

session, no decision on Pam's objections could be rendered. Brown said he didn't buy any more merchandise in December than he did the year before, and that he opened only a few new accounts.

Mr. Shrimski asked Brown why his accounts receivable had shrunk from \$90,000 in January, 1907, to \$75,000 in June, 1907, and to \$35,000 in February, 1908, but Brown gave the inevitable answer, "I don't know." In answer to the question "Do you know anything about your business?" he replied, "I knew I was there."

Brown was then asked if he had sold anything to Max Weber, who kept a pawnshop on State St. At first he didn't know, but finally acknowledged he did sell something to Mr. Weber, but didn't know how much. He didn't know that lawyer Raphael, to whom he paid \$1,250 in four weeks, was a brother-in-law of Max Weber.

He said he had a safe deposit box in the Chamber of Commerce building, but there was nothing in it. He sat up straight at

The next examination is set for March 5 at 2:30 P. M.

An estimated inventory of the Brown stock is now placed at \$50,000 to \$60,000 cost.

Association Notes.

The officers of the Arkansas Retail Jewelers' Association are making a strong endeavor to interest every jeweler of the State, and to that end will probably issue invitations to all members of the trade to join at the earliest possible moment, calling attention to the good work accomplished at the recent convention held at Little Rock, Feb. 11 and 12. The photograph of some of the members who attended the convention has been forwarded by the association and appears herewith. The figure marked (1) is President E. A. Short, No. 2 is Secretary J. W. Johnson, No. 3 is Treasurer F. E. Farley and No. 4 is M. J. Johnson, the oldest retail jeweler in Arkansas, who



OFFICERS AND MEMBERS OF THE ARKANSAS RETAIL JEWELERS' ASSOCIATION AT CONVENTION HELD FEB. 11-12 AT LITTLE ROCK.

1. President E. A. Short. 2. Secretary J. W. Johnson. 3. Treasurer F. E. Farley. 4. M. J. Johnson, Oldest Jeweler in Arkansas.

he had surrendered \$37,000 worth of stock for \$27,000, and it is claimed that the capital stock of \$75,000 had been impaired by one-half. This does not show on the statement. In June, 1907, Brown made a statement to the Jewelers Board of Trade claiming assets of \$172,000 and liabilities of \$78,000. Mr. Waldeck testified that until a few days ago he did not know that Ben S. Mayer, his associate assistant cashier in the Continental National Bank, was a director in the corporation of Jos. Brown & Co. Jos. Brown then took the stand and, with a look of complacency on his face, completely lost his memory and couldn't find it. Every time Mr. Shrimski pinned him down to a question Brown's attorney, Hugo Pam, interfered and either told Brown not to answer or told Brown practically what to say, and all this in the face of the fact that the referee has held that Brown is entitled to counsel by courtesy only. As the referee was not present at the first

and snapped out his answers very quickly.

Brown claimed he did not know until the day before that Davidson & Block, the latter a cousin of his and a former employe, were running an auction store on Madison St. in the store formerly leased by him.

The second session on Wednesday brought J. Mehlman, Brown's former shipping clerk, to the stand. He said he didn't know anything about a load of goods sent to 1900 W. Polk St., and refused to go to Brown's former premises to look for it. Judge Landis issued an order for a bailiff to take Mr. Mehlman there, and Mehlman didn't take long to go. He said he couldn't find the receipt when he got there.

Meyer Block kept the room in an uproar of laughter by remarks that gave no information whatever of importance to the matter at issue.

All of Attorney Pam's objections at the previous session were overruled.

was an enthusiastic attendant at the convention.

The next meeting of the Oklahoma Retail Jewelers' Association will be held the latter part of this month in Oklahoma City, the exact date of which will be announced later. This association is making a strong effort to have established a minimum retail selling price on all watch movements, and is also trying to secure a minimum selling price on filled cases. Joseph Mazer, McAlester, Okla., the president of the association, is circularizing the trade in the new State, asking all jewelers to join and participate in the proceedings of the next meeting. The other officers of the association are: Vice-president, W. C. Pfeffel, Enid; secretary, F. C. Boasen, Oklahoma City; treasurer, G. F. Miller, Tonkawa. Executive Committee: W. H. Haupt, Bartlesville; N. H. McDuffy, Lawton, and A. W. Sanders, Prague.

ADDISON W. WOODHULL, President.
FRANK K. HUFF, Vice-President.

GILBERT T. WOODHULL, Treasurer.
WILLIAM J. McQUILLIN, Secretary.

MOUNT & WOODHULL,

IMPORTERS OF **DIAMONDS,**
OTHER PRECIOUS STONES,
PEARLS, ETC.

MAKERS OF

FINE
DIAMOND
JEWELRY.

26 Maiden Lane,
(Southwest Corner Nassau Street)

NEW YORK

EMERALDS, DIAMONDS
AND PEARLS

CABLE ADDRESS:
MILBAGG

BAGG & CO.
Successors to BAGG, PERINE & CO.
IMPORTERS
452 FIFTH AVENUE, at 40th Street
NEW YORK

TELEPHONE
NUMBERS:
917-918 BRYANT

RUBIES AND
SAPPHIRES



580.

FLOWER EFFECTS

OUR

Chrysanthemum Brooches

are sellers. The secret is price—\$18.50 up.
Well made, too.

CROSSMAN COMPANY, 3 Maiden Lane, N.Y.

DIAMONDS

TRY
US ON

Lissauer & Company
IMPORTERS

52-54 MAIDEN LANE, NEW YORK

"There is Nothing in the Art that we cannot do."

Special Attention

GIVEN TO OUT OF TOWN ORDERS

The International Gem Co., Inc.

12-16 JOHN ST., NEW YORK

TELEPHONE 1241 CORTLAND

Lapidaries and Importers of Precious Stones

SPECIALISTS IN REPAIRING AND REPOLISHING RARE AND VALUABLE GEMS
DRILLING—ENGRAVING—SLITTING

Changes Its Name.

Jewelers' League of New York Becomes
the Assurance League of America.

The adjourned annual meeting of the Jewelers' League of New York was held last Thursday afternoon at the Astor House to decide upon changing the name of the organization by adopting proposed amendments to the constitution, in pursuance of the resolution adopted at the annual meeting of the league, held on the evening of Jan. 28.

The meeting was called to order by President Street, who made a few remarks relative to the business in hand and called upon F. A. Marsellus, the secretary of the League, who gave a brief résumé of the history of the League and explained the benefits to be derived by a change in the name of the organization. He said:

Furthermore, as approximately over 60 per cent of our new members secured in the past few years were from outside occupations, why not do now what we will undoubtedly be forced to do later having the satisfaction in the future of knowing, through our action now, we were the means of making through a change in name, the league one of the foremost fraternal organizations in this country.

Under the proposed name, "The League," as it is affectionately called by most members, will still be the "League" whether "Jewelers'" or "Assurance" be the first part of the title.

After a brief discussion, President Street placed the question of the adoption of the following amendments before the meeting:

Amend Section 1 of Article I. by striking from said section the words "Jewelers' League of New York," and insert in lieu thereof the words "Assurance League of America."

Amend Section 4 of Article I. by striking from said section the word "Jewelers'" and insert in lieu thereof the word "Assurance."

Amend Section 1 of Article VI. by striking from said section the word "Jewelers'" and insert in lieu thereof the word "Assurance."

Amend Section 5 of Article VIII. by striking from said section the word "Jewelers'" and insert in lieu thereof the word "Assurance."

The league was originally organized in 1877 for the benefit of persons engaged in the jewelry trade and restricted to such. In 1890 the restrictions as to occupation was waived, virtually acknowledging at that time that the field in the jewelry trade was too limited or scattered to properly succeed as a trade's organization, yet to-day while the League is not a trades organization, existing in name only, still we are very seriously handicapped with the name of such.

The name "Jewelers" does not appeal to persons in other lines of business (and apparently not very strongly to jewelers, as only 7/10 of one per cent. of our members secured members last year), and owing to the same we are unable to organize sufficient lodges to conduct our business on the lodge system and secure the proper growth that all fraternal should.

A change of name would enable us to interest all in acceptable occupations.

To increase greatly in the future the benefit given in the past, with additional benefits.

To largely increase our business by increasing our operations through the lodge system, virtually without increase over our present cost, a benefit to all present members.

To operate at a lower cost per member than at present from which all would be benefited. And should enable your league to grow in the future so that your organization would be in the foremost ranks of true fraternal, not only in size and strength, but in the good done to others.

Leo Wormser then made a motion to accept the amendments as proposed; this motion was seconded by Geo. H. Hodenpyl, and unanimously carried. The amendments as adopted changes the name of the organization to "The Assurance League of America."

RETAIL JEWELERS MEET AT MINNEAPOLIS.

Members of Minnesota Association of Retail Jewelers Hold a Most Successful Convention in Minneapolis and Elect Officers.

MINNEAPOLIS, Feb. 26.—The Minnesota Association of Retail Jewelers has scored gain in the holding of the most successful convention the retail jewelers ever held in the State. Strenuous and persistent effort was made fully to advise every retail jeweler in the State of the importance of his meeting.

At an early hour Monday, the jewelers began to gather in large numbers. The first meeting was called to order at 2:45 p. m., by President G. H. Lang, Mankato.

A. E. Paegel, Minneapolis, was introduced, and gave the address of welcome, which was responded to by President Lang.

As all were anxious to know the results of the efforts made by the membership committee and State organizer, the report of that committee was called for, and a surprise was in store for most of those present. The committee reported that 29 applications had been received. This is by far the largest number ever received at one meeting.

Mr. Carpenter, of the South Bend Watch Co., was introduced and gave a short, pithy talk on "Salesmanship." He laid particular stress upon the folly of "knocking" your competitor. Mr. Carpenter's remarks were in a happy strain and included some witty and appropriate stories.

D. C. Spaulding, Wabasha, came forward with advice to the retail jeweler as to becoming more familiar with the lines of goods. He suggested that every jeweler study the assays of his line of goods, so that he may be able to say just what he is selling.

Remarks were made by a number of other members, also by Mr. Weibezahn, of S. O. Bigney & Co. Mr. Williams, of Zumbrota, gave a short talk on the position of the wholesale jewelers toward the association. He recommended that retail jewelers read trade journals, including those outside of their own lines, thereby becoming familiar with the retail business in general.

Mr. Paegal spoke on the character of merchants in the jewelry business and on the importance of obtaining the cash discount. He stated that no business could possibly succeed without paying particular attention to this item, as it in itself was the first basis of profit.

President Lang appointed the following members as a committee on resolutions: J. L. Williams, A. E. Barker, I. Reiner, C. W. Logan and J. C. Herdliska. The committee reported a number of resolutions, which were adopted. Among the most important was one changing of the name from the Retail Jewelers' Association of Minnesota, to the Minnesota Retail Jewelers' Association.

A resolution was also adopted, retaining the State organizer and making him a member of the executive committee.

The election of officers resulted as follows:

President, A. E. Barker, Minneapolis;

vice-president, J. C. Marx, of Shakopee; secretary, I. M. Radabaugh, Hastings; treasurer, I. Reiner, Hutchinson; director for three years, E. Geist, St. Paul; director for two years, J. C. Herdliska, Princeton.

On Tuesday, at 9:30 a. m., the meeting reconvened and President Hurlbut, of the National Association, was introduced and delivered one of his witty and well directed talks along the line of advertising. His address was well received and a vote of thanks was extended to him.

Grievances were scarce, there being only one of any consequence, which was turned over to the grievance committee for investigation.

The report of the finance committee was to the effect that the books were correct and that a balance remained in the treasury of nearly \$500.

Delegates were elected to the National Association's convention in Cincinnati, as follows: F. W. Harper, Renville; J. C. Marx, Shakopee; J. C. Herdliska, Princeton; Geo. R. Clark, St. Cloud; A. E. Paegel, Minneapolis; N. S. Nelson, Hutchinson; J. D. Lifquist, Henning; Emil Geist, St. Paul.

After impromptu remarks by several members, the meeting was adjourned to reconvene at the Commercial Club at 6:30 p. m., where a banquet was enjoyed.

Mr. Paegel, of Minneapolis, acted as toastmaster, and introduced the following speakers:

"Organization," A. E. Barker, Minneapolis; "The Past Year's Record," George Lang, retiring president; "What the National Association Has Accomplished for the Welfare of the Jewelers," Mack A. Hurlbut, Fort Dodge, Ia.; "Classification of Merchandise," Emil Geist, St. Paul; "The Association's Work," A. Slouder, of Springfield, Ill.; "Advertising," I. M. Radabaugh, Hastings; "The Possibilities of the Future Jewelry Trade," J. C. Herdliska, Princeton; "Conditions of the Jewelers' Trade in St. Paul," J. Gaskell, St. Paul; "Competition," George Munns, Minneapolis; "Wake Up Your Brother," W. F. Harper, Renville; "Finances," I. Reiner, Hutchinson; "Window Display," J. D. Bedford, Minneapolis; "Good Fellowship," John McNaught, Minneapolis.

Much good feeling prevailed, and everybody said that they had had one of the best times of their lives.

Hearing on New York Optometry Bill Before Legislature at Albany, N. Y.

ALBANY, Feb. 29.—Physicians and optometrists wrestled for three hours, last Thursday afternoon, over the Wilcox-West bill to create a State Board of Examiners to license all optometrists in the State.

Drs. Van Vleet and Lambert, of New York; President Meyerowitz, of the State Opticians' League, an organization of manufacturing opticians formed to oppose the

bill, and Champe Andrews, of New York, objected to the bill on the ground that it would admit to the practice of medicine quacks and fakers. A letter was read from Dr. Hubbell, of Buffalo, stating that the Erie County Medical Society opposed the bill.

The optometrists were represented by President E. E. Arrington, of the New York State Optical Society, and B. B. Clark, chairman of the society's legislative committee; W. W. Bissell, Rochester; H. P. Simcox, president of the Erie County Optometrical Society; W. M. Kenney, Utica, and A. A. Martin, A. Jay Cross and P. A. Dilworth, New York.

The argument of the optometrists was that they desired to prevent incompetent persons from practising on the eyesight of the people. They asserted that the bill was to protect the eyesight of posterity.

Death of Urbanus Stahler.

ALLENTOWN, Pa., Feb. 26.—Friends of Urbanus Stahler, jeweler and repairer at Tamaqua, Pa., were grieved to hear, last week, that he had died at that town as a result of a paralytic stroke.

Mr. Stahler, who was about 68 years old, had been in business at Tamaqua for many years, and had been especially successful in building up an excellent repair trade. He was highly regarded in the community and was prominent in many ways. He was a public-spirited citizen and was also noted as one of the Pennsylvania Cornet Band, with which he played the piccolo for over 30 years. He was a charter member of the Tamagua Club and Camp 525, P. O. S. of A.

Deceased leaves a widow and five children: Mrs. Wellington Billig, Philadelphia; Mrs. Leroy Sterling, of Haddonfield, N. J.; Mrs. Andrew Raab, Mrs. George Brinton, and Harry, of this place. Funeral services were conducted at the home, Wednesday, by Rev. George Gebert, and interment was in the 'Odd Fellows' Cemetery.

William H. Shepherd, Celebrated Maker of Artificial Eyes, Dies at Taunton, Mass.

TAUNTON, Mass., March 1.—William Herbert Shepherd was laid to rest yesterday, and with him passed away valuable secrets in a unique branch of optical industry—the making of artificial eyes. He learned the trade in England, and for years the British government took all his product, under a contract. At its expiration he came here and opened a business, his product being in demand not only all over the United States, but also in Europe and Asia.

Deceased developed important secret processes which made his handiwork in a class by itself. This was especially true in the making of artificial human eyes. His artificial eyes of animals were in demand for taxidermists, and he developed these also by individual processes.

To a male relative he taught some of his secrets concerning animal eyes.

Curtis Brown, formerly with Daniel Silver, Lawrence, Mass., has gone to Havana, Cuba, as a member of a regimental band.

WM S. HEDGES & CO.,

IMPORTERS AND CUTTERS OF

DIAMONDS.

Precious Stones and Pearls.

170 Broadway, Corner Maiden Lane, New York.

27 Holborn Viaduct, London.

JAGERSFONTEIN

and other Gem Diamonds

SAUNDERS, MEURER & CO.

65 Nassau Street

NEW YORK

Goodfriend Bros.
IMPORTERS OF **PEARLS**

Sapphires
Rubies
Opals
Emeralds

Aquamarines
Peridot
Gem Coral
Tourmalines

AGATE, LALAGE, JADE, TURQUOISE, SAPHIRE, MOONSTONE, RUBY, EMERALD, SPINEL, CATSEYE, HYACINTH, JACINTH, OLIVINE, BERYL, PERIDOTS, GARNET, ESSONITE, TOURMALINE, PEARL, ALMANDINE, GOODFRIEND BROS. Copyright 1895 by

and OTHER
Precious and Imitation Stones

PEARL-OPAL-CORAL & AGATE NECKLACES

PARIS: 10 Rue Cadet.
PROVIDENCE: 212 Union St.

9-11-13
**Maiden Lane
NEW YORK**

Geo. Brunswick, N.Y.

Bids Received and Contracts Awarded by Government Departments to Supply Various Articles.

WASHINGTON, D. C., Feb. 26.—The Bureau of Supplies and Accounts, Navy Department, is inviting proposals until March 3 for the following items of hollow silver plated ware, to be of new patterns: 3 sugar bowls, 38 casters, without cruet; six chafing dishes, 27 fish dishes, 27 fruit dishes; 50 meat dishes, from 10 to 20 inches; 4 vegetable dishes, three 3½-quart ewers, 4 gravy boats and 38 gravy ladles, 18 half-pint cream pitchers; 16 water pitchers, six syrup pitchers, six two-pint and 63 pint teapots; six smokers' sets, 24 celery dishes, six three-pint coffee pots, 72 salt shakers, 7 pepper shakers, 76 waits, 12 and 18 inches; 10 baking dishes, 31 butter dishes.

In addition to the foregoing bids will be received on the same date for the following items of flat silver-plated ware, also of new pattern: 264 dessert forks, 152 table forks; 348 dessert knives, 468 table knives, 12 butter knives, 396 coffee spoons, 12 mustard spoons; 72 salt spoons, 492 teaspoons, 60 dessert spoons, 48 table knives and 72 teaspoons.

All to be delivered at the Brooklyn Navy Yard within 30 days of date of contract.

WASHINGTON, D. C., Feb. 26.—The Bureau of Supplies and Accounts is inviting proposals until March 3 for 144 mercurial thermometers for the League Island Navy Yard, from 0° to 212°, 10-inch copper cases.

WASHINGTON, D. C., Feb. 27.—The award for a large quantity of silver-plated ware for the Brooklyn Navy Yard, for which bids were opened on Feb. 11, has been made to the only bidder, the International Silver Co., Meriden, Conn., at their bid of \$3,343.63.

Foreign Trade Opportunities for Manufacturers of Watches, Clocks, Jewelry, Glass Ware, Etc.

WASHINGTON, D. C., Feb. 29.—An American consul in southern Europe reports that a prominent jeweler in the city in which he is located is desirous of handling high grade American-made gold and silver watches, especially ladies' watches.

Another American consul reports that the proprietor of a large store in the European city in which he is located is about to open a general store in Egypt and would like to receive catalogues and price lists from American manufacturers of chandeliers, electric light, gas and oil, cut and pressed glass ware, furniture, silverware, watches, clocks and jewelry, guns and revolvers, umbrellas and canes, leather goods, and other articles suitable for a department store.

Manufacturers, wholesalers or exporters interested in the above can obtain full particulars from the Bureau of Manufactures, Washington, D. C., by referring to the numbers of the consuls' communications respectively 2001 and 2003.

H. S. Proctor and James R. McIntyre, Jr., have formed a partnership and purchased the stock of Grinnell & Co., Valley City, N. Dak.

TO REGULATE MARKING OF WATCH CASES.

Important Measure Introduced Into Congress by Hon. E. B. Vreeland Seeks to Abolish Guarantees and Provide for Quantity and Quality Marks.

WASHINGTON, D. C., March 2.—The following is the text of a bill in regard to the stamping of gold-filled watch cases, which was introduced by Congressman Vreeland Saturday, Feb. 29. THE CIRCULAR-WEEKLY correspondent was informed that the bill has been submitted to all the prominent manufacturers of gold-filled watch cases, and that its provisions meet with their general approval, except as to one or two minor details, and also of the retail trade. The bill has been prepared under the direction of George Cook, a well-known patent lawyer of New York, who has been in frequent conference with the various members of the trade in respect to the same. The bill reads:

AN ACT FORBIDDING THE IMPORTATION, EXPORTATION OR CARRIAGE IN INTERSTATE COMMERCE OF GOLD FILLED OR GOLD PLATED WATCH CASES BEARING WORDS OR MARKS IMPORTING A GUARANTEE OF WEAR FOR A SPECIFIED TIME AND FOR OTHER PURPOSES.

Be it enacted by the Senate and House of Representatives of the United States of America in Congress assembled:

That it shall be unlawful for any person, firm, corporation or association, being a manufacturer, wholesaler or retail dealer in, watch cases made in whole or in part of an inferior metal having deposited or plated thereon, or brazed or otherwise affixed thereto, platings, coverings or sheets composed of gold or of an alloy thereof and which watch cases are known in the market as "gold filled," "rolled gold plate," "gold plate," "gold electro plate," or by any similar designation, or for any officer, manager, director or agent of such firm, corporation or association, to import into or export from, or cause to be imported into or exported from, the United States for the purpose of selling or disposing of the same, or to deposit, or cause to be deposited in the United States mails for transmission thereby, or to deliver or cause to be delivered to any common carrier for transportation, from one State, Territory or possession of the United States, or the District of Columbia, to any other State, Territory or possession of the United States or to said district in interstate commerce, or to transport or cause to be transported from one State, Territory or possession of the United States or from the District of Columbia to any other State, Territory or possession of the United States, or to said district in interstate commerce any such watch case manufactured after the date when this act takes effect, and having stamped, branded, engraved or imprinted thereon or therein, or upon any tag, card or label attached or applied thereto, or enclosed therewith, or upon any box, package, cover or wrapper in which such watch case is enclosed or enclosed, the word "guaranteed" or the word "warranted," with other words or marks indicating the time or duration of wear, or any mark or marks designed or intended to indicate the length of time that such watch case or the plating, covering or sheet of gold or of its alloy in such watch case will last or wear, or any word or words, mark or marks, indicating or importing or designed or intended to import time permanence or duration.

Section 2. That no watch case made in whole or in part of an inferior metal having deposited or plated thereon or brazed or otherwise affixed thereto a plating, covering or sheet composed of gold or of an alloy thereof and known in the market as rolled gold plate, gold plate, gold filled, or gold electro plate, or by any similar designation, which watch case or any tag, card or label attached or applied thereto, or enclosed therewith, or any box, package, cover or wrapper, in which such watch case is enclosed or enclosed, is stamped, branded, engraved or imprinted with any word or mark usually employed to indicate the fineness of gold, shall be so imported into or exported from the United States, or so deposited in

the United States mail for transmission, or so delivered to any common carrier, or so transported or caused to be transported, as specified in the first section of this act, unless accompanying such mark or words usually employed to indicate the fineness of gold and in close proximity thereto and upon the same such case, tag, card, label, box, package, cover or wrapper, there also be stamped, branded, engraved or imprinted words, letters or figures plainly indicating that such watch case or part thereof is made of rolled gold plate, gold plate or gold electro plate, or is gold filled, as the case may be, and also unless accompanying such mark or words usually employed to indicate the fineness of gold and in close proximity thereto and upon the same such case, tag, card, label, box, package, cover or wrapper there also be stamped, branded, engraved or imprinted words or figures plainly indicating in the decimal part of an inch the thickness of the exterior and interior plates, coverings, or sheets of gold or of its alloy upon such watch case, provided that no words or figures indicating or purporting to indicate the thickness of such exterior or interior plates, coverings or sheets of gold or of its alloy, shall be stamped, branded, engraved or imprinted upon such watch case or such tag, card, label, box, package, cover or wrapper, except in conjunction with words or marks usually employed to indicate the fineness of gold. If the thickness of the plates, coverings or sheets of gold or of its alloy upon the exterior of such watch case shall differ from the thickness of those upon the interior, the first in order of such words or figures shall indicate the thickness of the plates, coverings or sheets on the exterior of the watch case, and the second shall indicate the thickness of the plates, coverings or sheets on the interior of such watch case; and, if the thickness of such plates, coverings or sheets shall not be uniform on either the exterior or interior of such watch case, the words or figures so stamped, branded, engraved or imprinted shall refer in each instance to the plate, covering or sheet of least thickness on such exterior or interior. The indicated thickness of any plate, covering or sheet composed of gold or of its alloy upon such watch case shall not exceed the actual thickness of such plate, covering or sheet by more than half of 1,000th of an inch.

Section 3. That each and every person, firm, corporation or association being a manufacturer of or wholesaler or retail dealer in such watch cases described in Section 1, who or which shall knowingly violate any of the provisions of this act, and every officer, manager, director, or managing agent of such corporation or association, having knowledge of such violation and directly participating in such violation or consenting thereto, shall be deemed guilty of a misdemeanor, and, upon conviction thereof in any court of the United States having jurisdiction of crimes within the district in which such violation was committed, or through which has been conducted the transportation of the watch case in respect to which such violation had been committed, shall be punished by a fine of not more than \$500, or imprisonment for not more than three months, or both, at the discretion of the court. Whenever the offense is begun in one jurisdiction and completed in another, it may be dealt with, enquired of, tried, determined and punished in either jurisdiction in the same manner as if the offense had been actually and wholly committed therein.

Section 4. That any such watch cases described in Section 1 which shall have been transported into any State, Territory, district or possession of the United States, and shall remain therein for use, sale or storage shall, upon arrival in such State, Territory, district or possession, be subject to the operation of all the laws of such State, Territory, district or possession of the United States, to the same extent and in the same manner as though such watch cases had been produced in such State, Territory, district or possession, and shall not be exempt therefrom by reason of being introduced therein in original packages or otherwise.

Section 5. Wherever the words "watch case" are used in this act, they shall be taken to include any watch case described in the first section of this

act, whether the same does or does not contain a movement or does or does not form part of a complete watch.

Wherever the word "exterior," as applied to a watch case, is used in this act, it shall be taken to mean all those parts of a watch case which are exposed to view or wear when the case is closed, other than the crown, but including the backs or lids, the center, the pendant and the bow and, if an open face case, the bezel.

Wherever the word "interior," as applied to a watch case, is used in this act, it shall be taken to mean those interior surfaces of a watch case that are usually covered with a sheet of gold, including the inner surfaces of the backs or lids, the inner and outer surfaces of the cap covering the movement and, if a hunting case, the outer surface of the bezel.

Section 6. That this act shall take effect six months after the date of its passage.

Nebraska State Optical Society Holds Convention.

LINCOLN, Nebr., Feb. 27.—The annual meeting of the Nebraska State Optical Society was held here yesterday in the Lincoln Hotel. Officers for the ensuing year were elected, standing committees were chosen and a movement looking toward the establishment of a permanent circulating library for opticians was adopted. The following officers and committees were chosen: President, Fritz Hoefler, Aurora; first vice-president, F. A. Hannis, York; second vice-president, Mr. Preston, Oxford; secretary, J. H. Hukill, Lincoln, and treasurer, John Holts, Omaha.

Executive committee: C. W. Bowlby, Omaha, chairman; F. A. Hallett, Lincoln; E. A. Polleys, Seward, and F. T. Johnson.

Examining board: W. D. Vail, Wayne; M. L. Jones, Fairfield, and D. L. Davis, Nelson.

Legislative committee: A. B. Tarbox, Omaha, chairman; D. M. Davies, Falls City; H. P. Sutton, McCook.

A paper entitled "The Color Sense," dealing with the causes of color blindness and written by A. F. Thompson, Adel, Ia., was read at the morning session, Mr. Thompson being unable to be present himself.

W. B. Ankeny, Corning, Ia., read a paper in the afternoon on "Muscular Anomalies."

C. C. Leese, president of the society, gave a talk on a case of crossed eyes. Dr. Campbell, Topeka, Kans., spoke on "The Health Ray Lens."

Mr. Hukill, Lincoln, and the secretary of the society will have charge of the library. Books will be purchased at the request of members and will be sent according as desired.

A report showed that the society was in good condition financially and otherwise. Forty new members have been added since last year.

A vote of thanks was tendered J. C. Hutson, Omaha member of the State Board of Examiners, for his untiring efforts in enforcing the Optometry Law.

Ernest Jeunet, a leading resident of Franklin, Pa., who died, Feb. 19, of apoplexy, was at one time well-known in the jewelry trade. Mr. Jeunet, who was 65 years old, was born in the Department of Montbozon, France, and when about 11 years old came to America with his father. He located at Meadville, where he later engaged in the jewelry business, but became a telegraph operator and for many years had charge of the Western Union office in Franklin.

BLACK OPALS

REMARKABLE :: IRIDESCENT :: BEAUTIFUL

Black Opal, a recent Australian discovery, is one of the most beautiful stones hitherto found.

With it many inimitable jewelry creations are possible that must appeal in a forceful manner to the trade.

These remarkable stones exhibit a wonderful play of brilliant colors, ranging from light to cobalt blue, with flashes of violet, from delicate shades of green to peacock green, and all shades of reds, merging into orange and yellow tints.

Black Opal is a worthy addition to the finest stock, and jewelers will find it a welcome "Trade Magnet."

We can furnish these stones in various sizes and shapes, and their full merits can only be appreciated by being seen.

We make a specialty of AUSTRALIAN and MEXICAN OPAL MATRIX.

BUY FROM THE CUTTERS

AMERICAN GEM & PEARL COMPANY

14 & 16 CHURCH STREET, NEW YORK

London, 16 Holborn Viaduct

Paris, 39 Rue de Chateaudun

FROM MINES TO MARKET

Second Annual Convention of the Nebraska Retail Jewelers' Association Held at Lincoln.

LINCOLN, Nebr., Feb. 28.—The second annual meeting of the Nebraska Retail Jewelers' Association was held yesterday in the Lincoln Hotel. The meeting was the largest yet held in this State, representatives from jobbers and factories being present, and a great many opticians remaining over from their convention held the day before. Officers for the coming year were elected as follows: George Arkright, Beatrice, president; E. A. Polleys, Seward, vice-president; T. L. Combs, Omaha, secretary-treasurer. An executive board consisting of H. J. Engles, Fairbury, and H. E. Howard, Hastings, was chosen.

The association will meet two days of next year in Omaha.

Six delegates were elected to represent Nebraska, at the annual meeting of the National Jewelers' Association, which is to be held in the first week in August at Cincinnati, O. The delegates are: George Arkright, Beatrice; J. A. Rueling, Wymore; T. L. Combs, Omaha; Fritz Hoefler, Aurora; Max Egge, Grand Island, and F. A. Hannis.

The morning session opened with a short address by President J. A. Rueling, Wymore. He said that through illegitimate and dishonest competition, the jeweler's business had suffered more than any other, and he suggested legislation as the remedy. Mr. Rueling announced that it is the intention of the association to publish a monthly magazine.

Max J. Egge, Grand Island, secretary and treasurer, reported the finances to be satisfactory. The membership has reached 125, with a promise of further growth.

T. L. Combs, Omaha, spoke on The National Association.

M. L. Hurlbut, the national president, spoke on "Benefits of Organization." He advocated that retailers should, when possible, co-operate with jobbers and manufacturers. He read a paper on the proper advertising for retail jewelers.

The afternoon session was called at 2 o'clock. George Arkright, Beatrice, read a paper on "The Jewelry Business 25 Years Ago."

Fritz Hoefler, Aurora, told of his early experience, as a proprietor of a store, and how he purchased a carload of clocks, which he was compelled to sell on time.

An address by Mr. Higgenbotham, of the South Bend Watch Co., was most interesting. It was technical and was illustrated by a number of charts.

The next address was by M. D. Franks, Omaha, who spoke on "Initiative Versus Defensive Methods of Business." W. H. Wagner, Cleveland, O., spoke on "The Watch Trust." Many of those present said that they doubted the existence of such a trust. Mr. Wagner read letters that had been used in the discussion of the subject at Washington, on the identity of interest among some of the companies, to support his position.

David B. Knowles, Lawrence, Mass., whose father died a short time ago at an advanced age, is heir to the estate of the elder Mr. Knowles.

CORAL

All Kinds of Coral Specialties for Jewelers

DROPS
BUTTONS
LENTILLES

CORAL
NECK-
LACES

All Shades and Sizes
Graduated and Uniform



CORAL MANUFACTURING COMPANY

CORAL

Extra Rose
CORAL
A Specialty

Gold Medal
St. Louis, 1904

Grand Prix
Liege, 1905

BORRELLI & VITELLI

3 Via Amedeo,
Terre del Greco Italy

401 Broadway, New York
Telephone, 5412 Franklin

19 Rue d'Hauteville,
Paris, France

Tel. 4457 } Cort.
4458 }

JOHN M. RICHARD 2 MAIDEN LANE
Room 302, NEW YORK

American Pearls and Baroques

MATCHED PAIRS FOR EARRINGS

The Largest and Finest Assortment in the Market, Mounted and Unmounted.

A. O. Brittain and Frank North Indicted by Federal Grand Jury on Charge of Using Mails to Defraud.

LAS VEGAS, N. Mex., Feb. 26.—M. O. Brittain and Frank North, whose photographs are shown herewith, were arrested at Raton, N. Mex., recently, on the charge of using the mails to defraud, on which charge they were indicted by a Federal Grand Jury here, Feb. 21, and are held here awaiting a trial before the District Court, in May.

The postal authorities desire to learn something of the identity and antecedents of North, but think they have sufficient evidence against Brittain to convict him.

Brittain was a street car conductor in Los Angeles, Cal., about three years ago, and went into business as a jeweler at Meson, Ariz., where he remained until

recently frightened Brittain as he disappeared without obtaining any credit so far as is known.

Early in February, he sent orders from Raton to a Kansas City music house, and to the W. W. Hamilton Jewelry Co., Denver, signing himself Allen & Allen, of Los Angeles, Cal., and stating that his firm was opening a branch store at Raton. His handwriting was recognized by the Denver firm and the letter turned over to the post-office authorities. After investigating the case, Brittain and North were placed under arrest by a post-office inspector.

Credit for Brittain's arrest is largely due to Chas. B. Lewis, of the Lewis Jewelers' Supply Co., Denver, who has made it his particular business for some time to bring Brittain to justice.

If any of the members of the trade have

Manufactures of Agate, Chalcedony, Chrysolite, Coral, Etc., to Be Assessed for Duty at 50 Per Cent.

The jewelry and gem trades were notified last week by special Deputy Appraiser Clapp that, acting under the instruction from the Secretary of the Treasury, a change in the classification of manufactures of agate, alabaster, chalcedony, chrysolite, coral, etc., will go into effect March 16. After that date this merchandise will be classified by the Appraiser at the rate of 50 per cent. ad valorem, under Par. 415 of the Tariff Law, instead of 10 per cent. under Par. 435, as precious stones advanced in value by cutting, etc.

The action of the Treasury Department in ordering this change is said to be based on the recent decision in the suit of the United States vs. Lorsch, wherein agate bearings were declared by the United States Circuit Court of Appeals to be dutiable as manufactures of agate at 50 per cent., thus reversing the United States Circuit Court and the Board of General Appraisers, which declared them dutiable at 10 per cent. The Appellate court held that the section providing for manufactures of these stones was more specific and more applicable to bearings, which were complete for manufactures than was the section for precious stones, although the court had held previously that similar articles, though manufactures, were nevertheless dutiable by similitude, at 10 per cent.

The question that has agitated the jewelry trade has been how far the Collector or the Appraiser will consider the word "manufacture" to apply, or whether all articles not distinctly made for use as precious stones that are to be set in jewelry, will be dutiable at 50 per cent. under this ruling.

It is said that some of the importers had seen the Assistant Secretary of the Treasury on the subject asking him to change his ruling, but that he refused to do so, and that the Appraiser had no other alternative than to follow the order of the Treasury Department and promulgate the ruling of the above-mentioned notice.

Convention of Minnesota State Association of Optometrists.

MINNEAPOLIS, Feb. 26.—The leading address at the eighth annual and 14th semi-annual meeting of the Minnesota State Association of Optometrists, held Monday at 804 Nicollet Ave., was made by I. M. Rada-baugh, Hastings, president of the association, who urged the discouragement of the sale of optical goods to catalogue or mail order houses.

Forty members of the association were present. An interesting feature was the presentation of a case for ophthalmoscopic examination by P. C. Hirschy. John C. Eberhardt, Dayton, O., lectured on "Optometrical Methods of Precision, Both Objective and Subjective."

New members of the Association were elected as follows: T. V. Moreau, Minneapolis; Frank A. Ubel, J. P. Hoeltgen, St. Paul; W. H. Cowley, Detroit; E. W. Larson, Bemidji; C. H. Anderson, Chatfield; J. F. Sullivan, Blackduck; O. C. Retzlaff, Winnebago.



FRANK NORTH.

Accused of using the mails to defraud.



M. O. BRITTAIN.

September, 1906. He then went to Denver, which was his headquarters, for the next three or four months, from which point he sold watches, jewelry, etc. largely among railroad men, being himself a member of the "Brotherhood of Railroad Trainmen." During that time he conducted stores for a short time at Sterling, Colo., and at Laramie, Wyo.

He left Denver, suddenly, early in January of 1907, considerably in debt to several Denver wholesale houses. He was lost sight of for a time, but turned up last December at North Platte, and later at Columbus and Fremont, Nebr., under the name of M. Bloom, and under that alias, representing himself to be M. Bloom, a jeweler of Tacoma, Wash., he obtained goods from Omaha jobbers to the amount of \$1,500 to \$2,000 and disappeared.

He went to St. Louis, Mo., and under the name of E. Lipke, turned another trick, among his creditors being one of the large ring houses.

In January last, he appeared at Kansas City, Mo., under the alias of J. E. Converse, representing that he was the son of Jesse Converse, a retired jeweler of Laramie, Wyo., and that he was going to open a store at Fort Scott, Kan., but before extending him credit, the Kansas City jobbers started investigations which evi-

information which would assist in the prosecution of these two men, particularly the identification of North, they should communicate with either the Lewis Jewelers' Supply Co., or the W. W. Hamilton Jewelry Co., who will place such evidence in the hands of the postal authorities.

Death of William H. Dewey.

LONDON, Ont., Feb. 26.—William Henry Dewey, an old-time jeweler, died in this city, Feb. 21, in his 79th year. He came to Canada when quite young. His father, William Dewey, London, Eng., was a first cousin of the father of Admiral Dewey. The deceased bore a marked resemblance to the admiral in features and physique. He is survived by a sister.

Market Price for Silver Bars.

The following are the quotations of silver bars in London and New York, as reported by Zimmermann & Forshay:

	London.	New York, .999 Basis.
Feb. 25.....	25 13-16d.	\$.577½
" 26.....	25 11-16d.	.577½
" 27.....	25 1-2d.	.57¼
" 28.....	25 1-2d.	.57¼
" 29.....	25 9-16d.	.57¾
March 2.....	25 13-16d.	.57¾

EICHBERG & CO.,
 IMPORTERS AND CUTTERS OF
DIAMONDS,
 65 NASSAU STREET, (Prescott Building.) NEW YORK.

HIMALAYA MINING COMPANY
 MINERS AND CUTTERS OF
 PRECIOUS AND SEMI-PRECIOUS STONES
 537 FIFTH AVENUE
 LONDON OBERSTEIN
 PARIS NEW YORK PROVIDENCE

A. ROSEMAN, 9-11-13 Maiden Lane, New York
 IMPORTER OF
DIAMONDS
 Maker of Diamond Jewelry

Established 1872
 HEADQUARTERS FOR
AMERICAN WATCHES
 TRADE-MARK.

VARISCITE SOHN & HYMAN
Sole Agents
 47-49 MAIDEN LANE
 The Newest Stone for High Class Jewelry NEW YORK

ARTHUR REICHMAN
 BUYS AND SELLS
AMERICAN BAROQUE PEARLS
 65 Nassau St. New York

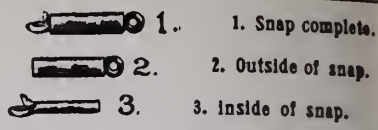

**The E. P. H. Patent
 NON-PULL-OUT
 Neck Chain Snap**

*is a patented snap that insures
 the wearer against loss of*
CHAIN or CHARM
for it positively will not pull out

**Made in 10 and 14 Karat Gold and
 in Gold Filled.**

*Can be had of the following Wholesale
 Selling Agents:*
 Messrs. W. Green & Co.,
 81 Nassau St., New York

M. Sickles & Sons,	Philadelphia
E. A. Cowan & Co.,	Boston
E. & J. Swigart,	Cincinnati
Swartchild & Co.,	Chicago
Nordman Brothers,	San Francisco
Leonard Krower,	New Orleans
A. Walker Co.,	Providence, R. I.
Bauman-Massa Jewelry Co.,	St. Louis
H. S. Meiskey Co.,	Lancaster, Pa.
The Edw. Lehman Jewelry Co.,	Denver, Col.

PRICES.

14 Karat—Small, \$7 per doz. net
 Large, \$7.50 per doz. net

10 Karat—Small, \$6 per doz. net
 Large, \$6.50 per doz. net

Gold Filled—Small, \$2 per doz. net
 Large, \$2.25 per doz. net

PRACTICAL COURSE IN ADJUSTING
 Published Price, \$2.50.
 Special Reduced Price, \$1.50, Postpaid.
 All Jobbers or Jewelers' Circular Publishing Co.

AN EXAMPLE OF A GREAT ACHIEVEMENT IN THE MANUFACTURE OF
 IMPORTED WATCHES IS EVIDENCED IN

“Tavannes” Movements and “Cyma” Watches

WHY?



Because all features heretofore existing that have been an obstacle to the modern watchmaker have been eliminated—being brought about by the introduction of automatic machinery in the manufacture of these goods, and the concentration of our mammoth factory on a modern scale, enabling us to furnish “FINISHED MATERIAL” ready to use.

“TAVANNES” movements and “CYMA” watches give most satisfactory results when exposed to the extreme influence of TEMPERATURE, ELECTRICITY or MAGNETISM.



TAVANNES WATCH COMPANY

131 Wabash Avenue Chicago ADOLPHE SCHWOB, Sole Agent for the U. S. 704 Market Street San Francisco
 2 and 4 MAIDEN LANE, NEW YORK

Death of James Hedges.

In the death of James Hedges, senior member of the firm of William S. Hedges & Co., importers of diamonds, 170 Broadway, New York, which occurred last Saturday at his country home at Allenhurst, N. Y., of heart disease, the diamond trade lost one of its most highly respected members. Mr. Hedges was known in the gem industry as a conservative business man, reserved in his manner, yet always ready to lend a helping hand.

James Hedges was born in New York, Jan. 10, 1836, and spent his early life in that city, where he attended the public schools. When about 18 years of age he was engaged as a clerk by a James McCulloch, a member of the produce exchange, with whom he remained for a time. In April 1871 he entered the employ of Smith & Hedges, 1 Maiden Lane, of which firm his brother William S. was a member. He later became a member of the firm, whose name was changed to Smith, Hedges & Co.

In 1878 the firm of Smith, Hedges & Co. was dissolved and the two brothers, William S. and James Hedges formed the firm of William S. Hedges & Co. and began business at 170 Broadway. Mr. Smith and his brother formed the firm of Alfred H. Smith & Co.

William S. Hedges died in 1886 and the business was continued under the same style by his brother James. Feb. 1, 1905, Frank Jeanne and Charles L. Roos, former employes, were admitted to the firm.

Mr. Hedges was a member of the Chamber of Commerce, New York Athletic Club, the Museum of Natural History, the Metropolitan Museum of Art, a 33d degree Mason and a member of the York and Scottish Rite. He was a member of Washington Lodge No. 33, F. and A. M., Elizabeth, N. J.

Funeral services will be held from the late New York home of the deceased, 272 W. 86th St., this evening at 7.30 p. m., Rev. Dr. Jefferson, of the Broadway Tabernacle, officiating.

The interment will take place at the convenience of the family.

Deceased is survived by a widow, one son and one daughter.

Death of James E. Tyler.

RICHMOND, Va., Feb. 26.—James Evans Tyler, who died at St. Luke's Hospital last week was for many years prominent in the jewelry trade and was highly esteemed in business and social circles. He is survived by a widow, one daughter and two sons.

Mr. Tyler was born in Richmond in 1841, and was the son of John H. Tyler, a member of the old jewelry firm of Mitchell & Tyler. James E. Tyler was educated in the jewelry trade, but his business career was interrupted by the Civil War, and he became a member of Company F, the First Virginia Infantry. He served with distinction on the Confederate side, and after the war started in the jewelry business, becoming head of the firm of J. H. Tyler & Co., which continued for several years. Mr. Tyler finally bought out the interests of his brothers in 1886 and continued the business alone for some time. Of recent years he had been connected with the business of Schwarzschild Bros.

Mr. Tyler was noted as a gallant soldier, having fought in every battle with General Lee up to Appomattox, and was prominent among the Confederate Veterans. A detail from Lee Camp attended the services Wednesday, which were conducted by Rev. Dr. J. H. Dixon. The interment was in Hollywood.

Bankrupt Jeweler Sues Creditors and Attorneys Who Caused His Arrest in a Civil Suit.

Joseph Haskell, who was formerly* in business at 37 Maiden Lane, has brought an action through his attorneys, Sternberg, Jacobson & Pollock, against Ingomar Goldsmith & Co. and their attorneys, Felix Levy and Saul S. Myers, for \$50,000 damages.

In March, 1907, the defendants Goldsmith, acting for themselves and other creditors, through their attorneys fought Haskell in bankruptcy proceedings and also started a suit in the State courts in which a civil order of arrest against Mr. Haskell was obtained, which was subsequently set aside by a decision of the Appellate Division of the Supreme Court on the ground that the service of the order was not proper.

The complaint in this action brought by Mr. Haskell states that an involuntary petition in bankruptcy was filed against him in October, 1904, and that he was arrested while returning from a hearing before a referee in bankruptcy on a civil order of arrest in an alleged action in the Supreme Court to recover \$1,111.72. The complaint states that the plaintiff was a resident of Philadelphia, Pa., at the time of the arrest, and alleges that he was exempt from service and the action of the defendants was a malicious abuse of process.

The action is brought in the Supreme Court of New York County.

Tragic Suicide of Jacob C. Worst.

MEADVILLE, Pa., Feb. 26.—The tragic death of Jacob C. Worst, a well known jeweler of western Pennsylvania, who committed suicide in his home in this city Monday night by blowing his head off with a shotgun, was a great shock as well as a surprise to his many friends in the trade. Mr. Worst had suffered with dropsy for two or three months past, and it is believed that the pain and suffering made him despondent.

The tragedy took place shortly after six o'clock in the evening. His wife had called him to supper and he answered that he would be down directly, but a few minutes after a shotgun's report was heard and it was found that Mr. Worst had placed the muzzle of a double-barreled shotgun in his mouth, held it with his left hand, while with the right hand he pulled the trigger. His head was almost torn from his body.

Mr. Worst had been in the jewelry trade for many years. He was the son of the late Charles Worst, who started in business about 1868, and was associated with his father for a long time. Mr. Worst was a well known sportsman and was one of the best trap and wing shots of western Pennsylvania.

Fritz Hoefler has begun excavation work for an addition to his jewelry store in Aurora, Nebr.

Alabama Retail Jewelers Hold Annual Convention at Mobile.

MOBILE, Ala., Feb. 29.—The members of the Alabama Retail Jewelers' Association met yesterday at the Commercial Club at the second annual session, but owing to the busy season in Mobile a number of the local jewelers were unable to attend and only a small number from other parts of the State was on hand.

President Richard Heine, of Talladega, who presided, made an excellent address, which was ordered spread upon the minutes of the association and that it be printed in the official organ of the association.

The same officers were requested to continue in office until the next meeting of which the time and place will be determined later by the association. The officers are: Richard Heine, Talladega, president; C. L. Ruth, Montgomery, vice-president; Patrick H. Linnehan, Birmingham, treasurer; Max Robinson, Birmingham, secretary.

After the annual meeting all the visiting jewelers were guests of the Gabriel Jewelry Co. at a supper held at the Carothon Hotel.

Importations at the Port of New York.

Weeks Ended Feb. 23, 1907, and Feb. 22, 1908.		
	1907.	1908.
China, Glass and Earthen Ware:		
China	\$74,639	\$83,681
Earthen ware	9,028	12,093
Glass ware	36,290	20,592
Optical glass	446	6,816
Instruments:		
Musical	23,614	22,219
Optical	6,920	7,138
Philosophical	2,714	1,524
Jewelry, etc.:		
Jewelry	22,629	7,653
Precious stones	1,292,424	68,976
Watches	26,612	21,833
Metals, etc.:		
Bronzes	1,427	348
Cutlery	8,858	26,156
Dutch metal	1,722	3,504
Platina	98,090	20,111
Plated ware
Silverware	847	98
Miscellaneous:		
Alabaster ornaments	265	1
Amber	1,550	3,820
Beads	7,177	3,216
Clocks	4,252	2,061
Fans	15,306	3,435
Fancy goods.....	13,397	9,879
Ivory	28,902	25,991
Ivory, manufactures of..	251	122
Marble, manufactures of.	31,833	11,056
Statuary	7,565	2,861

Jewelers' Gold Bars Withdrawn and Exchanged at New York.

Week Ended Feb. 29, 1908.	
The U. S. Assay Office reports:	
Gold bars exchanged for gold coin.....	\$232,005.92
Gold bars paid depositors.....	35,739.94
Total	\$267,745.86
Of this the gold bars exchanged for gold coin are reported as follows:	
Feb. 24.....	\$48,950.71
" 25.....	37,012.62
" 26.....	60,199.92
" 27.....	37,325.59
" 28.....	27,943.35
" 29.....	20,573.73
Total	\$232,005.92

The stock of jewelry, dry goods, etc., of John R. May, Lexington, Nebr., has been destroyed by fire.

The marriage of Miss May Durand and Reginald R. Rowley, formerly employed in the Booth store, in Ortinville, Minn., occurred recently.



Made for St. Luke's Church,
Marietta, Ohio.

EASTER, the most important feast day of the Church, will soon be here. This day is made the occasion for presentation to Churches in all denominations, of memorial and other gifts of great variety. The Gorham Company are manufacturers of Church metal work in all its branches, viz.: Communion Sets, Altar Brasses, Alms Basins, Chalices, Ciboria, Monstrances, Memorial Tablets, etc., and they take this means of suggesting to the trade that their wants in this line be made known to the Company at an early date, to obviate the possibility of disappointment as to date of delivery.

Literature illustrating this line may be had upon application, and The Gorham Company hold themselves in readiness to lend all assistance in their power toward securing orders.

THE GORHAM COMPANY,

Silversmiths and Goldsmiths

Fifth Avenue and 36th Street, New York.

BRANCHES:

CHICAGO,
137 Wabash Ave.

NEW YORK,
23 Maiden Lane.

SAN FRANCISCO,
Temporary Office:
1103 Broadway, Oakland, Cal.

LONDON,
Ely Place.

WORKS: Providence and New York.

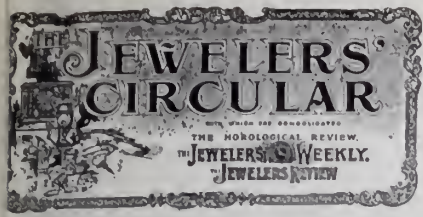

PUBLISHED EVERY WEDNESDAY BY THE JEWELERS' CIRCULAR PUB'G CO. J. Mulford, Pres. & Treas. V. S. Mulford, V. P. & Sec. 11 JOHN ST., COR BROADWAY, NEW YORK. TELEPHONE: 448 GORTLANDT. CABLE ADDRESS: JEWLAR, NEW YORK.

VOL. LVI. MARCH 4, 1908. No. 5.

Subscription in United States and Mexico, \$2.00 Dominion of Canada, 3.00 Other Countries in Postal Union, 6.00 Single Copies, .10

Remit by check or money order. Remittances in money are at sender's risk.

Index to News and Special Articles.

Table with 2 columns: Article Title and Page. Includes entries like 'Original Design of Silver Plaque for International Automobile Trophy', 'The Designer of Modern Silverware', 'Increase in Thefts at Jewelry Factories of the Attleboros', etc.

THE Chambre Syndicale des Megociants en Diamants, of Paris, has, in circular form, published the correspondence between the president of this body and the Diamond Syndicate, the De Beers Consolidated Mines, Ltd., and the Premier Mining Co. in regard to the policy which these three will pursue in the future.

THE Jewelers' League of New York, the trade's old and well known fraternal and insurance association, which was incorporated in 1877, is now the Assurance League of America, final action on changing the name having been taken at the adjourned annual meeting held at New York, last week.

The Duty on Agate, Chalcedony, Coral, Etc. THE notice sent out from the office of the Appraiser of the Port of New York last week to the effect that after March 16 manufacturers of agate, alabaster, chalcedony, chrysolite, coral, etc., will be classified by that office under Par. 115 of the Tariff Act at 50 per cent, has caused no little surprise, inasmuch as such a classification appears not only to be contrary to the spirit in which the Tariff Act has been interpreted by the customs authorities recently, but at variance with a long line of decisions of the United States Board of

Five Hundred and Thirteen NEW subscribers to the JEWELERS' CIRCULAR-WEEKLY have been added to our lists during January and February, 1908. All are buyers and possible customers of our advertisers.

General Appraisers, the United States Circuit Court and the United States Circuit Court of Appeals.

The action of the Appraiser, of course, does not come on his own initiative, but is in accordance with instructions received from an Assistant Secretary of the Treasury, who claims to base his ruling on a recent decision of the United States Circuit Court of Appeals on a protest of Albert Lorsch & Co. How the Treasury Department has been able to interpret the decision in question as necessitating such a ruling on all articles composed of these stones is very hard for the layman to see, particularly so when the decision of the court which was written by Judge Lacombe is read in connection with previous decisions on similar questions by the same court (which were also written by the same judge), in which the 10 per cent. duty under Par. 435, covering precious stones, was sustained.

It has not only been conceded, but, as a matter of law, agate, chrysolite, etc., are precious stones; in fact, were declared so by the United States Circuit Court of Appeals back in 1893 in the case of Erhardt vs. Hahn, which decision confirmed the principle previously laid down—that an article is deemed a manufacture only when it has been advanced through one or more processes into a complete commercial article known and recognized in the trade by a specific and distinctive name other than that of the material of which it is composed, and consequently articles made of agate, etc., remain precious stones for tariff purposes whether they be in their original condition or advanced by cutting, etc., as long as they remain stones in the commercial sense of the word, and are not known by a name other than the substance of which they are composed. A few years ago the United States Circuit Court of Appeals in the case of Hahn vs. the United States reiterated this principle and sustained the contention of the importers that agate and onyx handles for pen holders, knives, paper weights, etc., were dutiable under the same clause as precious stones by similitude, being identical in material with certain kinds of precious stones, although advanced by manufacture into specific commercial articles.

It will be recalled that in the decision in the case of the United States vs. Lorsch, in which agate bearings are held to be manufactures of agate, the United States Circuit Court of Appeals laid stress on the fact that these bearings have become complete manufactures and that nothing further is required to fit them for the specific use for which they are intended, and that they are ready to be fitted into the grooves.

FIRST HANDS



CROSS & BEGUELIN

Importers and Cutters of Diamonds and Precious Stones.

43 Rue de Meslay, PARIS

Telephone,
480 John

31 Maiden Lane, NEW YORK



The Silent Appeal

H. A. KIRBY

FINE
GOLD
JEWELRY

PROVIDENCE
NEW YORK

HAVE YOU EVER REFLECTED ON HOW A PRETTILY WROUGHT AND EFFECTIVELY DISPLAYED DESIGN WILL UNCONSCIOUSLY INFLUENCE A PURCHASE? HOW FIRST IT EXCITES ADMIRATION IN THE INDIFFERENT SPECTATOR, THEN IRRITATES THE DESIRE TO POSSESS, AND FINALLY BY ITS VERY IRRESISTIBILITY COMPELS HIM TO PURCHASE? IN EFFECTING SUCH A SALE, ONLY A FEW CONVENTIONAL REPRESENTATIONS ARE NECESSARY BY THE JEWELER, WHOSE PROFITS ARE A JUST REWARD FOR HIS SHREWDNESS IN EQUIPPING HIMSELF WITH SUCH JEWELRY. WE MAKE IT IN AN INEXHAUSTIBLE VARIETY—AT MODERATE COST.

prepared for their reception in the completed scales. It is true that the court also says (in the paragraph relied upon by the Treasury Department), "When Congress selects by name one of those species and provides that manufactures of that particular stone shall be dutiable at a different rate, it so clearly indicates its intention to withdraw the article from the general group as soon as it has become a completed manufacture, that the absence of the words 'not specially provided for' in the paragraph covering the grouping is not particularly significant," but we think, however, that a careful reading of the above opinion in connection with the previous decisions of the court clearly indicates that as long as articles of agate, chalcedony, chrysolite, etc. can be considered stones to be used as such they are properly dutiable under the provisions of Par. 435 at 10 per cent., covering precious stones cut, and that they cannot be considered as coming under Par. 115 at 50 per cent. until they appear in the form of completed manufactured articles.

We do not doubt that any attempt by the customs officials to collect a duty of more than 10 per cent. on agate, chalcedony, chrysolite, etc., which is not in the form of a complete manufactured article will be successfully resisted by importers, but we think it is an injustice to cause such a test case to be made, as it would unnecessarily and unjustly put importers to a large amount of expense and inconvenience as well as tie up a considerable amount of capital pending the adjudication of the suit. If the Treasury Department intends that this recent ruling applies only to articles completely manufactured, it should so notify the trade at once, but if it intends it to apply the ruling to articles that are in any way used in the jewelry trade it should rescind the order before the courts, and show that it has no validity.

LETTERS TO THE EDITOR.

Mr. Montgomery Corrects a Report.

PITTSBURG, Pa., Feb. 28

Editor THE JEWELERS' CIRCULAR—WEEKLY

I beg that you correct an error in the report of your local reporter, which was published in your paper, Feb. 26.

Our company is not curtailing the territory covered from this office. How such a report could have started we are at a loss to understand, as we have put out four men since the first of the year, when we only had two in 1907. We have largely increased their stocks and also the territory covered by them; in fact, we expect to be seeing twice as many customers by July 1, as we were seeing last year. So far as I have been able to learn, we are conducting the most aggressive campaign of our history.

Regarding the further report that it was my intention to go to Chicago—it is again in error, as I will remain as the active manager of the Pittsburg office as in the past. While I have been elected to the position of vice-president of the company and it will require trips to the home office from time to time, my active work will continue to be done here.

Very truly yours,
J. T. MONTGOMERY,
Manager for M. A. Mead & Co.

New York Notes.

Irving Lederer sailed for Europe yesterday on the *Kaiser Wilhelm II*.

Michele Gallo, 36 Mulberry St., has been succeeded by A. Gallo and G. Volpe.

Robt. Ingersoll & Bro., 51 Maiden Lane, will remove to 45 John St. about May 1. The firm of Schraga & Golden, 238 Leecker St., has been succeeded by Isidor Chraga.

M. Landmann, with Frederick W. Gessen, 90 Nassau St., is making a trip through the south.

Henry C. Haskell, designer and maker of jewelry, who was formerly at 9 Maiden Lane, has moved to 38 W. 33d St.

Mr De Waters, of the C. G. Braxmar Co., 10 Maiden Lane, who has been at home for two weeks with a sprained ankle, is able to be at the office again.

Judge Holt, of the United States District Court, Monday, granted a discharge in bankruptcy to Isaac W. Sproder, a jeweler, at 65 Nassau St., whose debts amount to 19,063.

The opening of the Memorial Exhibition of the Works of Augustus Saint Gaudens was held Monday evening at the Metropolitan Museum of Art from 8.30 p. m. until 11 p. m.

It is reported that F. M. Kauderer, who has conducted a store at 598 Broadway, Brooklyn, for some time past, has purchased the business of M. H. Woodhull, Patchogue.

The firm of Bagg, Perine & Co. has been succeeded by Bagg & Co. W. D. N. Perine, who, with Milton P. Bagg, composed the old firm, is now a member of the firm of Dreicer & Co.

L. O. Levison, California Jewelry Co., San Francisco, Cal., arrived in New York Monday on the *Amerika* and visited the office of THE CIRCULAR-WEEKLY. He started directly for his home.

The firm of Dieges & Clust, 23 John St., has been incorporated under the laws of the State of New York with a capital of \$100,000. The directors are: Charles J. Dieges and Herbert M. Seem, New York, and Prosper Clust, Brooklyn.

A. M. Hill, Jr., of Hill & Schmidt, has been very ill for the past six weeks. His friends, however, will be glad to hear he is recovering slowly and hopes to be back to his office this week. The following week he will call on his regular trade.

A warning is given to the trade to beware of two young men about 25 years old and about five feet eight inches high, with smooth-shaven faces, of slim build, dark, both dressed in dark suits. Diamond houses are specially warned to look out for these men.

The Castle Co. has been incorporated under the laws of the State of New York to manufacture jewelry, optical goods, etc., with a capital of \$25,000. The incorporators are: C. N. Brewster, J. F. Brewster, W. F. Mangels and E. Mangels, Coney Island.

Notice is given to the creditors of Eisler & Laubheim, bankrupts, that they may, on application at the offices of Olcott, Gruber, Bonyng & McManus, 170 Broadway, on and after March 10, 1908, receive the notes for the composition as confirmed by the

court. The composition was for 50 cents on the dollar.

His Majesty, King Haaken, of Norway, has conferred the decoration of Chevalier of the Cross of the First Class of the Royal Order of Saint Olav upon Dr. George F. Kunz, the gem expert. The decoration of Chevalier Legion d' Monnen was given him in 1907.

At a recent meeting of the board of directors of the Merchants' Association of New York a report of the Committee on Bankruptcy and Commercial Law, recommending the indorsement of the Fowler bill, was received and a resolution was adopted indorsing the bill.

F. J. Whiton has sub-let for Jos. S. Acker the store at 18 Maiden Lane until May 1, 1909, and has leased the same premises for the owner (Jas. G. Powers) for a further term of 10 years to John Frick, who will occupy the same for his jewelry and medal business in connection with his present location at 8 Liberty Place, adjoining.

Judge Platzek, of the Supreme Court, has appointed the Carnegie Trust Co. and Henry Schneider temporary receivers of the Oriental Bank, 182-184 Broadway, on application of Attorney-General Jackson, and fixed their bond at \$300,000. The order to show cause to make the receivers permanent was set down for March 24. The officers and depositors of the bank will fight the receivership proceedings in every way possible.

A meeting of the creditors of Adolph Hodes, 65 Nassau St., who filed a petition in bankruptcy some time ago, was held at the offices of Referee in Bankruptcy William Allen last Thursday. J. Epstein, attorney for the bankrupt, was unable to attend the meeting because of sickness, and his brother, representing the bankrupt, asked for an adjournment. To-day, at 11.30 A. M., at the same place, was decided upon for the next meeting.

A decision handed down Monday by the Board of United States General Appraisers declares that artificial rubies and emeralds and imitation pearls drilled through are not jewelry within the meaning of the Dingley tariff. The ruling was called forth by protests of Frederics & Co. and others who objected to the classification of 60 per cent. imposed by the Collector. The Board decided that the artificial rubies, emeralds, etc., are dutiable at 10 per cent., while the artificial pearls are dutiable at 20 per cent.

Harry Levinson, who was formerly employed as a traveling salesman by Freudenheim Bros. & Levy, 54 Maiden Lane, and who was arrested in Chicago and brought to this city charged with the larceny of jewelry belonging to the firm, as told in a recent issue of THE CIRCULAR-WEEKLY, pleaded guilty last Friday before Judge Mulqueen in Part IV of General Sessions to larceny in the first degree. The specific indictment was stealing a diamond worth \$700. He stole much more, however. He will be sentenced to-morrow.

H. J. Bridger, 472 Fulton St., Brooklyn, has executed a deed transferring all his assets to A. H. Kirkpatrick, L. Veit and M. H. Mason as trustees. They have the power to dispose of the stock and collect accounts and whenever they have sufficient

funds to pay 10 per cent. of the liabilities they are to distribute same to creditors. This agreement remains in force until Sept. 1, 1909, when, if the creditors are not all paid up, the trustees can dispose of business in any way they see fit and distribute the proceeds to the creditors.

There has been on exhibition during the past week at the Fifth Ave. salesrooms of the Gorham Co. a solid silver wreath, which is to be sent by the Swedish-Americans of New York to the bier of King Oscar II. At the bottom of the wreath is the Swedish coat-of-arms, and on either side are the dates Jan. 21, 1829 and Dec. 8, 1907. At one side of the coat-of-arms is the flag of Sweden and on the opposite side is the American flag, both enameled in proper colors. The wreath, which is most artistically made, is the work of the company exhibiting it.

Willis G. Nash, of the National State Bank, of Albany, has been elected president of the Mercantile National Bank, to succeed Seth M. Milliken, who resigned. William H. Taylor, vice-president of the Bowling Green Trust Co., was elected vice-president, to succeed J. Milliken, and William Skinner, who was made a vice-president after the resignation of the Heinze-Morse-Thomas contingent, was re-elected. Miles M. O'Brien was the only officer of the bank under the old management to remain. He was re-elected first vice-president.

Figures given out at the Appraiser's stores in this city show a decided falling off in the importation of precious stones cut and pearls and in precious stones uncut for the month of February. In February, 1907, the amount of precious stones cut and pearls reached \$3,456,284, as compared with \$24,583 for the same time this year. The amount of precious stones uncut imported in February, 1907, amounted to \$819,016, while the amount this year in February was \$24,583. The total in February, 1907, was \$4,275,300, as compared with \$200,443 for the same time this year.

A petition in involuntary bankruptcy was filed in the United States District Court, New York, last Thursday, against Samuel Eisenberg, New Rochelle, N. Y., by Louis Dolgin, \$349; Henry Stone, \$69; Arsenstein & Woronock, \$63, and Louis Anguss, \$65. It is alleged that Mr. Eisenberg owes debts to the amount of \$2,000 and over and is insolvent. It is also alleged that he made preferred payments and that he admitted his insolvency in writing. Mr. Eisenberg opened a store at 37 Mechanic St., New Rochelle, in October, 1903. He moved to his present address at 25 Mechanic St. in 1905.

Friends in the trade learned with regret of the death of Maurice Maas, secretary and treasurer of the Maiden Lane Safe Deposit Co., which occurred last Thursday at his late home, 31 W. 124th St. He had been ill about two months. Mr. Maas, who was 53 years of age, was born in Durkheim, Germany, and came to this country 35 years ago. For a number of years he was cashier of the Manhattan Bank in Memphis, Tenn., coming from there to this city. The funeral services were held Sunday from his late home and

ESTABLISHED 1852

THE NASSAU BANK

Original Clearing House Member

Corner Nassau and Beekman Streets - - - - NEW YORK

Title Guarantee and Trust Co.

176 Broadway (between John St. and Maiden Lane), New York

Capital and Surplus - - - - \$12,000,000

Deposits received subject to Check. Interest allowed. Letters of Credit issued. Drafts drawn on Great Britain and the Continent. All Banking Facilities afforded to Customers. Accounts of Jewelers are especially solicited.

Finance Committee in Charge of Banking Interests

E. T. BEDFORD, 26 Broadway
C. H. KELSEY, President
E. L. MARSTON, of Blair & Co., Bankers
W. H. NICHOLS, General Chemical Co.

CHARLES A. PEABODY, President Mutual Life Ins. Co.
JACOB H. SCHIFF, of Kuhn, Loeb & Co.
JAMES SPEYER, of Speyer & Co.
E. O. STANLEY, 2d Vice-President

BRANCH BANKING OFFICES: 196 Montague St. and 175 Remsen St., Brooklyn; 350 Fulton St., Jamaica; 67 Jackson Ave., Long Island City

The Market and Fulton National Bank of New York.

ORGANIZED 1862

81-83 FULTON STREET.

Capital, \$1,000,000.

Surplus, \$1,500,000.

PROGRESSIVE — CONSERVATIVE — SUCCESSFUL.

ALEXANDER GILBERT, President.
R. A. PARKER, - Vice-President.
T. J. STEVENS - - - Cashier.
JOHN H. CARR - Asst. Cashier.

Invites the Accounts of Jewelers.

Will extend every facility that good banking will justify

SAFE DEPOSIT VAULTS.

THE STATE BANK

376-378 GRAND STREET, NEW YORK

Capital and Earned Surplus, over \$1,500,000. Deposits over Fifteen Millions

Offers a favorable market for short and long time jewelry and diamond paper.

The Mercantile National Bank

OF NEW YORK

WILLIS G. NASH, President

MILES M. O'BRIEN, Vice-President

WM. SKINNER, Vice-President

WILLIAM H. TAYLOR, Vice-President

EMIL KLEIN, Cashier

DIRECTORS

WILLIAM F. CARLTON,
ROBERT C. CLOWRY,
WILLIAM NELSON CROMWELL,
L. H. CUTTER,
EDWIN GOULD,
HAROLD A. HATCH,

EDWARD T. JEFFERY,
WILLIAM H. LAWS,
WILLIS G. NASH,
BENJAMIN NICOLL,
MILES M. O'BRIEN,
CHARLES E. PERKINS,

DICK S. RAMSAY,
WILLIAM SKINNER,
E. D. STREET,
WILLIAM H. TAYLOR,
E. J. TRUSSELL,
WARNER VAN NORDEN,

Strictly a Commercial Bank
Accounts Solicited

1851

The Jewelers' Bank for half a century
in the same location.

1908

The Chatham National Bank

OF NEW YORK

Broadway and John Street

CAPITAL	-	-	-	-	-	\$450,000
EARNED SURPLUS	-	-				\$1,000,000

Accounts Solicited

DIRECTORS

GEORGE M. HARD, President
 JOHN H. WASHBURN, Retired
 SANFORD H. STEELE, Vice-President
 General Chemical Co.
 FRANK R. LAWRENCE, Attorney
 DANIEL J. CARROLL, Lumber

JOHN D. VERMEULE, President
 Goodyear India Rubber Glove Co.
 G. P. MOROSINI, Banker
 HENRY F. SHOEMAKER, Banker
 WILLIAM B. CONRAD, White Goods
 FRANKLIN S. JEROME,
 Treasurer U. S. Finishing Co.

FRANK J. HEANEY, Exporter
 SAMUEL WEIL, Capitalist
 LEWIS COON, Real Estate
 O. G. FESSENDEN,
 of Hayden W. Wheeler & Co.,
 Jewelers.

GEORGE M. HARD, President
 WILLIAM H. STRAWN, Cashier
 HENRY L. CADMUS, Assistant Cashier

SEND YOUR SWEEPS to the Cincinnati Gold & Silver Refining Co.

REFINERS, ASSAYERS AND SMELTERS

Office, 523 Elm Street; Works, 2257 Eastern Avenue; CINCINNATI, OHIO

Highest Price Paid for Gold, Silver and Platinum Platinum and Gold Fillings Refined by the Russian Method

PRACTICAL COURSE IN ADJUSTING

Published Price, \$2.50.

Special Reduced Price, \$1.50, Postpaid.

The Jewelers' Circular Pub. Co., 11 John St., N. Y.



W. H. SAART
President



GEO. J. KELLEY
Treasurer



F. B. PLATT
New York Representative



F. R. TRUELL
Western Representative

The Four Men who Have Been Instrumental in Making
THE W. H. SAART CO.

ATTLEBORO, MASS.

The Leading Sterling Silver Novelty House in the United States

Bags Buckles Sash Pins Vanity Cases Hat Pins

New York Notes.

(Continued from page 65.)

interment was in Cypress Hills Cemetery. Deceased is survived by a widow and three children.

Julius Mamluck & Co., 68 Nassau St., earn the trade to give no goods on memorandum to any one purporting to come from them without a written order from the firm.

Among those who have already leased space in the Frankel building, at the corner of John and Dutch Sts., are the Keller Bldg. Co., A. & E. Esposito, W. L. Sexton & Co., John Werner, Benjamin Sugarman, Jeandheur and A. Rosenthal.

The meeting of creditors of Edwin W. Dayton, 4 W. 39th St., against whom a petition in bankruptcy was filed some time ago, which was called for Monday afternoon at the offices of Referee Allen, 67 Vall St., was postponed until Monday, March 9, at 11:30 A. M. at the same place.

The trade is warned to be careful in dealing with a young man giving the name of Albert See, who has been calling on jewelers in this city, asking for diamond jewelry to be sent to a hotel in order that he be inspected by his father. He is described as five feet six inches high, with black hair and a little black mustache. He is about 30 years old.

Wilbur Irving Follett, president of the Follett Time Recording Co., who died Friday night at the Beechwood Hotel, in Summit, N. J., was buried Saturday from the home of his father-in-law, Samuel Streit, 3 Lincoln Park, Newark. Deceased, who was the inventor of the time recording stamp and time clock which bears his name, was a descendant of President John Adams. He was born in New York in 1867 and was graduated in 1890 from Columbia University.

A short but exciting fire occurred Saturday afternoon on the third floor of the building at 23 John St., in which is located the electroplating establishment of Charles Schaefer. The department responded quickly and prevented the spread of flames. The damage by fire, smoke and water is estimated at \$1,500. The fire was caused by the igniting of several gallons of lacquering fluid. The other floors of the building are occupied by Dieges & Clust and by Geo. Linde, an engraver.

I. Goodman, Butte, Mont., Goes Into Voluntary Bankruptcy.

BUTTE, Mont., March 2.—A voluntary petition in bankruptcy has been filed by I. Goodman, trading as the Northwestern Supply & Jewelry Co., of this city. Mr. Goodman made an offer of 30 cents in settlement, but some of the creditors would not accept the offer.

The assets are estimated at \$4,500 in merchandise and \$8,000 in instalment accounts, and the liabilities are about \$19,000 to \$20,000.

Mr. Goodman has been in business about six years. In October, 1905, he purchased the business of Max Goldstein at Great Falls, but later moved his stock to Butte.

A. C. Brannon has moved from Montezuma, Ga., to Roanoke, Ala.



W. H. Hovey, of J. B. Whitney & Co., San Francisco, is now in Seattle, Wash.

The following traveling salesmen are among those reported to have called on the trade in Kansas City, Mo., during the past week: Mr. Armbruster, Illinois Watch Co.; Chas. H. Ide, Farrington Mfg. Co.

Among the traveling representatives of eastern houses recently in San Francisco were Mr. Andrews, Alsopp & Alsopp; Edw. Childs, Cohn & Co.; Frank Shirek, Deitsch Bros.; Mr. Schwab, Ciner & Seelmann.

Travelers in Denver, Colo., last week included: David Feiss, Ingomar Goldsmith & Co.; Frank Thompson, Derby Silver Co.; E. A. Hall, Holmes & Edwards Silver Co.; Mr. Lowell, Watson & Newell Co.; Mr. Domic, Herman F. Hahn & Co.; Dave Fice, C. P. Wilson.

Among the traveling representatives in Los Angeles, Cal., recently were Carl Plate, Julius Young; George Miller, Gorham Co.; Adolph Goldsmith; Theodore Lyons, Lyons Gem Co.; A. P. Wood; Jacob Marx, Kossuth Marx Jewelry Co.; Mr. Crouch, California Jewelry Co.; Mr. Mitchell, Schussler & Co.; Albert Lowenthal.

Among the traveling salesmen visiting New Orleans, La., recently were: Mr. Cunningham, E. L. Spencer Co.; Mr. Kleckner, Theo. W. Foster & Bro. Co.; Murray Kohn, Silbermann, Kohn & Walenstein; Mr. Shattuck, W. & S. Blackinton Co.; Mr. Sinnock, Ehrlich & Sinnock, Geo. Goldberg, Untermeyer-Robbins Co.; Mr. Sandfelder, D. P. Briggs Co.

Among the traveling representatives in Lancaster, Pa., recently, were: John H. Baker, Jacobson Bros.; Mr. Chaddeston, Jennings Bros. Mfg. Co.; J. Spear, E. A. Bliss Co.; Mr. Fake, Whiting Mfg. Co.; J. Fred Crane, Mandeville, Carrow & Crane; Louis E. Stern, Rice & Hochster; Ferd. Levy, Ferd. Levy & Co.; Mr. Cohen, Levy & Cohen; Charles H. Israel, Quaker City Cut Glass Co.; George L. Shepardson, C. A. Marsh & Co.; Louis Hodges, E. A. Potter Co.

The following traveling representatives visited the trade at Pittsburg, Pa., last week: Max Huss, S. Borgzinner Co.; Jacob Schorsch, Emrich, King & Schorsch; W. H. Osborne, R. Wallace & Son-Mfg. Co.; Arthur Bradshaw, Meriden Britannia Co.; Fred H. Felger, F. & F. Felger, R. H. Schley, Sloan & Co.; Mr. Fay, T. I. Smith Co.; J. T. Griffith, Jr, Carter, Howe & Co.; H. N. Van Bergen, Snow & Westcott; S. C. Corbin, Waterbury Clock Co.; M. E. Loomis, C. Sydney Smith & Co.; Ernest A. Rose, Weigle & Rose; Jules Franklin; Mr. Wickerson, Carter Qvarnstrom & Remington.

Traveling representatives who called on the Cincinnati, O., trade during the past week included: N. Loeb, Dueber-Hampden Watch Works; F. H. Kehl, F. H. Nohle & Co.; Mr. Greene, George L. Brown & Co.; I. Price, Louis Strasburger's Son & Co.; A. N. Dorchester, Chapin & Hollister Co.; Fred H. Felger, F. & F. Felger; William J. McQuillin, Mount & Woodhull; J. M. Morrow, American Watch Case Co.; S. E. Bolles, William Scheer; Mr. Hofman, Eichberg & Co.; W. H. Osborne, R. Wallace & Sons Mfg. Co.; Mr. Dorchester, W. E. Richards & Co.; Mr. Boss, Standard Button Co.; S. C. Corbin, Waterbury Clock Co.; Mr. Fay, T. I. Smith Co.; W. R. Elhot, Meriden Cut Glass Co.

Traveling representatives in Omaha, Nebr., last week, were: E. C. Bell, Omega Watch Co.; M. Lewkowitz, D. Ullman & Co.; Chas. H. Ide, Farrington Mfg. Co.; William T. Smith, International Silver Co.; Henry E. Hart, Albert Lorsch & Co.; Arthur Totten, Sanshury & Nellis; A. M. Breckenridge, Benj. Allen & Co.; J. Leon Gross, Knickerbocker Silver Co.; Wm. H. Peer, Bristol Mfg. Co.; P. A. McCourt, A. C. Fry Cut Glass Co.; G. G. Pfordresher, Geo. L. Brown & Co.; Lew Gummhinner, M. Gugenheim; Alfred Goldsmith, Adolph Goldsmith & Son; L. M. Frank, Buffalo Jewelry Case Co.; H. A. Bliss, Wordley, Allsopp & Bliss Co.; F. A. Stern, F. M. Weintraub.

Traveling representatives in Indianapolis, Ind., recently included: Eugene Frommeyer, L. Gat-

mann & Sons; George A. Allsopp, Jr., Allsopp Bros.; Louis Freund, Henry Freund & Bro.; H. B. Kline, Stott Bros.; M. J. Vogel, Morris Vogel & Bro.; John F. Garland, L. H. Keller & Co.; F. F. Gibson, Gibson, Krugler Co.; M. E. Van Bergh, Van Bergh Silver Plate Co.; Ben Shier, Heintz Bros.; W. H. Kennon, Sigler Bros. Co.; J. C. Miller, Herman Keck Mfg. Co.; Ferd. Phillips, Richter & Phillips; M. F. Thornton, A. J. Hedges & Co.; J. Rothschild, Kaffeman, Rothschild & Co.; J. B. Osthoff, Jos. Noterman & Co.; H. L. Richards, Fessenden & Co.; J. Barnet, Lissauer & Co.

Jewelers' Bowling League of New York Preparing for Annual Banquet.

Members of the Jewelers' Bowling League of New York are looking forward to the annual dinner which is to be held on the evening of April 4, at the Broadway Central Hotel. The committee in charge of arrangements have left nothing undone to add to the pleasure of the evening, and it is needless to say that the menu will meet with general approval. Arrangements are being made for about 250 guests. Members who have not already secured tickets are urged to give the matter immediate attention. Tickets may be obtained from Henry Laboureur, 54 Maiden Lane. The committee in charge of the banquet consists of R. H. Woodrow, John F. Schierloh and Henry Laboureur.

The banquet will be an informal affair. It is expected that this year's banquet will eclipse all previous efforts of the club.

The following were the scores of the teams of the league in the games rolled last week:

Feb. 25.—Cooper Diamond Co.....	873	961	801
vs. Tiffany & Co.....	875	911	822
Feb. 26.—H. W. Wheeler & Co.....	734	701	781
vs. Aikin-Lambert Co.....	804	921	758
Feb. 27.—N. H. White & Co.....	879	865	904
vs. Cooper Diamond Co.....	795	755	866
Feb. 28.—Jos. Fahys & Co.....	896	791	951
vs. A. A. Webster & Co.....	791	840	720

STANDING OF TEAMS.

	Won.	Lost.	High score.	Per cent.
N. H. White & Co.....	38	13	1,014	.745
Cross & Bequelin.....	35	13	1,017	.729
Cooper Diamond Co.....	35	19	1,022	.645
C. F. Wood & Co.....	25	14	943	.641
Tiffany & Co.....	31	20	969	.608
Aikin-Lambert Co.....	28	23	967	.549
Jos. Fahys & Co.....	27	27	951	.500
A. A. Webster & Co.....	17	34	916	.333
H. W. Wheeler & Co.....	11	31	922	.268
Julius King Optical Co....	10	35	889	.222
L. E. Waterman Co.....	7	35	852	.159

Individual Averages—C. E. Roll, 197 24/51; Platt Adams, 190 21/45; E. E. Wood, 186 2/30; F. Schneider, 185 5/45; W. G. Wood, 184 23/36; W. C. Weber, 182 1/53; E. G. Howell, 181 24/54; R. H. Woodrow, 180 16/48.

High Individual Scores—G. H. Ertel, 266; C. E. Roll, 256; L. A. Goettler, 252.

Trans-Atlantic Voyagers.

FROM EUROPE.

L. O. Levison, San Francisco, Cal., returned Monday on the *America*.

TO EUROPE.

Irving Lederer, New York, sailed yesterday on the *Kaiser Wilhelm II*.

Edgar Hulen, of the Potter & Buffinton Co., New York, sailed recently.

D. Gruen, of D. Gruen, Sons & Co., Cincinnati, sailed Feb. 29 on the *Princess Irene*.

Anthony Serewicz, Chicago representative of the Dueber-Hampden Watch Works, sailed yesterday on the *Kaiser Wilhelm II*.

Lee H. Fuller has reached his 38th year of successful business in Waterville, Minn.

THE CLOSEST relationship exists between us and the Jobber. The latter is your convenient source of supply.



**BUY
UR
RINGS**

from your
JOBBER
as cheap as from
ring makers

The Untermeyer=Robbins Co.

Seventy-One Nassau Street, New York



S. BORGZINNER CO.

MANUFACTURERS and IMPORTERS

**82 and 84 Nassau St
NEW YORK**

LOUIS FELDENHEIMER

Importer and Cutter of

PRECIOUS STONES AND PEARLS

41 MAIDEN LANE

NEW YORK

Last Week's New York Arrivals

THE CIRCULAR-WEEKLY each day posts in its office a bulletin of the latest buyers visiting New York, which every member of the trade is cordially invited to copy.

BRIDGEPORT, CONN., J. C. Mizer (Howland Dry Goods Co.), 75 Spring St.

CHICAGO, J. D. French (Chas. A. Stevens & Bro.), Wellington; 487 Broadway.
Miss A. Mulcahey (Boston Store), Wellington; 377 Broadway.

COLUMBUS, O., J. G. Sikes (Z. L. White & Co.) Breslin.

INDIANAPOLIS, IND., W. Angrove (Pettis Dr. Goods Co.), 2 Walker St.
W. D. Sanford (Pettis Dry Goods Co.), Herald Sq.; 2 Walker St.

MONTGOMERY, ALA., J. D. Jessel (Montgomery Fair), Breslin; 214 Church St.

NORWICH, CONN., F. J. Stanley (Porteus & Mitchell Co.), 55 White St.

POTTSVILLE, PA., G. C. Abergast (Dives Pomeroy & Stewart), Herald Sq.; 2 Walker St.

TACOMA, WASH., W. H. Congar (People's Store Co.), 214 Church St.

WASHINGTON, D. C., W. Colman (J. Goldenberg), Grand, 65 Beckman St.

Newark.

The list of names of merchants who have agreed to close their stores early at Paterson includes the name of H. E. Botwick 157 River St.

The firm of Noble & Hunt, jewelers and silversmiths, have recorded articles of incorporation. The capital stock is \$50,000. The incorporators are Martin C. and Elizabeth A. Noble, of this city, and Barton M. and Addie S. Hunt, of Irvington.

A small blaze occurred last week when spark in the smelting room of Tiffany & Co.'s silverware factory, at Forest Hill, set fire to some crude oil which leaked from pump. When the firemen arrived they shut off the oil and the flames were quickly extinguished. The loss is estimated by Captain Martin, of the salvage corps, at \$300.

Theodore M. Willis, one of the oldest jewelers in this section, died at the Mountain Side Hospital, Sunday, of paralysis. Some time ago Mr. Willis, while entering his home in Valley road, fell and cut his head severely and was rendered unconscious. It was at first thought that his condition was improving, but he grew worse and could not rally. For 31 years Mr. Willis conducted a store in Bloomfield Ave. Deceased is survived by one daughter.

The Crescent Beneficial and Social Association, composed of employees of the Crescent Watch Case Co., celebrated its 23rd anniversary with a reception and dance at Shawger's Hall, Orange St. and Roseville Ave., recently. The affair proved a great success, as the attendance was the largest in the history of the association. After the performance refreshments were served and then dancing was carried on until early morning. The committee consisted of J. C. Steinbrunner, A. W. Fenwick, Willis I. Small, Martin Kiatt and Herbert Fleet.

Capt. E. H. Russell, who died at Chicago a short time ago, followed the jewelry trade in Providence after the Mexican War in which he served in the United States Navy. He remained in the trade until the Civil War broke out.

Report of the Directors of the Premier Diamond Mining Co., Ltd., Submitted to Shareholders.

LONDON, Feb. 25.—The following is the directors' report submitted to-day at the general meeting of the shareholders of Premier Transvaal Diamond Mining Co., Ltd. It covers the financial year ended on 31, 1907, and contains much information of interest.

to the Shareholders:

Gentlemen:—Your directors have pleasure in submitting their fifth annual report and balance sheet.

Mining Property.—Your mining property remains as at flotation, being the freehold of Prins's portion of Elandsfontein No. 85, District Pretoria, in extent 817 morgen, 431 square rods.

Freehold Property.—Your Freehold property has been added by the acquisition of a second portion of the farm Spitzkop, No. 31 (Wilgever), in extent 673 morgen, 420 square rods, and a portion of the farm Kamelfontein No. 106, in extent 286 morgen, 505 square rods, and your interest in all the farms is subject to the provisions of Ordinance 66 of 1903.

Expenditure and Revenue Account.—Account No. 1 discloses a profit of £865,728 19s. 11d., while Account No. 2 shows the distribution of this amount. The attention of shareholders is drawn to the fact that the amount of £164,000, represented by the stock of diamonds unsold at the end of the company's year, has been treated as undivisible profit for the present.

The following is a summary of the company's revenue and expenditure from its inception to date:

Working capital originally subscribed	£10,000 0 0
raised by issue of 3,000 reserve shares of £1 each	74,249 19 0
Industry revenue, including company's share of Cullinan diamond	116,682 0 0
Expenditure and revenue account (profit)	2,932,313 6 3
	£3,133,245 5 3

Accounted for as follows:

Transfer fees on property	£707 10 0
Equipment	1,206,717 13 8
Government	£708,208 9 11
Government reserve	240,000 0 0
Dividends	948,208 9 11
Reserve stock of diamonds (profit in suspense)	620,000 0 0
Dividend payment postponed (No. 3 deferred shares)	164,000 0 0
Balance	160,000 0 0
	33,611 11 8
	£3,133,245 5 3

The balance sheet has been supplemented by detailed schedules, giving fullest particulars of the different items.

Diamonds.—The production for the year amounted to 1,889,986½ carats, an increase of 90,240½ carats over last year.

Cullinan Diamond.—The Cullinan diamond has been presented by the people of the Transvaal to His Majesty King Edward VII., and the company may well be proud of the fact that this unique gem of its production will forever remain one of the crown jewels of the British Empire.

Sale of Diamonds.—The directors informed you in their last report of their desire to create a trading fund, so as to make the large amount then represented by stock of diamonds on hand available for the purposes of the company pending realization. It is a matter of satisfaction to the board to report that an offer was received in May last for the issue of £300,000 debenture stock (secured only by the floating stock of diamonds on quite favorable terms, but the Government preferred that the company did not issue debenture stock, and the offer had to be declined, a policy which proved correct in the light of after events.

The Market.—The market for diamonds, after a slight setback at the end of June last, became active again in August, and the London diamond office sold your production freely until sales were suspended by the board in view of the negotiations with the Diamond Syndicate, which negotiations culminated in the agreement of Oct. 23 last. This

syndicate has for the past 16 years contracted with the De Beers Consolidated Mines, Ltd., for the whole of that company's production, and your directors felt that by placing the sale of the Premier company's diamonds in the hands of this combination, who have heretofore practically controlled the diamond trade, they were acting in the best interests of the company. Certain relative proportions as to amounts to be supplied by the De Beers Co., and this company were agreed upon, and the first period of the contract, which provides for the sale to the syndicate of your production from July, 1907, to February, 1908, terminates in March next. It is to be regretted that since the date of the agreement the American crisis has had a most disturbing effect on the diamond market, and the reports received from the syndicate lead your directors to believe that the present depression may continue for some time longer, but it is bound to disappear with the improvement in the money markets, of which there are already very promising signs. Under these circumstances it is impossible to say definitely whether the syndicate will exercise its right to renew the contract for a further period, but your directors have no hesitation in stating that they are fully convinced of the desirability of supporting an effective monopoly for the sale of rough diamonds.

As the stocks of the syndicate in consequence of the depression are bound to be larger than usual, and, therefore, as it is likely that no call will be made, for the present anyhow, upon the company to increase the deliveries under the contract, the board resolved, as from Jan. 1 until normal conditions prevail, to discontinue operations with the No. 1 gear, the magnetic separator, and tube mill. These reductions, amounting to about 30,000 carats per month, have been agreed upon in consultation with the directors of the De Beers Consolidated Mines, Ltd., which company had already taken steps to reduce its output. In order to keep in close touch, both with the syndicate and the diamond market in London, the company has appointed W. Busch as its special representative. The directors consider they were particularly fortunate in securing in Mr. Busch a gentleman who brings to the service of the company a very wide knowledge of the complicated diamond business.

Mine.—The general manager's report gives the fullest account of the technical work at the mine. The board wishes to draw special attention to the very great increase in the quantity of ground handled, and the highly satisfactory decrease in the cost per load. Complete tables as to the yield are attached to the general manager's report, and call for no further comment.

Dividends.—The dividends declared during the year only affect the preference issue, namely:

No. 5, 125 per cent. for the half-year ended April 30, 1907, and paid June 5, 1907	£50,000
No. 6, 125 per cent. for the half-year ended Oct. 31, 1907, and paid Dec. 9, 1907	50,000

£100,000

The directors were keenly disappointed that the halting tendency of the diamond market prevented them from declaring a dividend in June last, and regret that the protracted disorganization of the trade and of the money markets rendered it prudent to delay payment of dividend No. 3 on deferred shares of 400 per cent. (10s. per share) declared in December last. Shareholders were immediately advised of this decision. The directors draw the attention of shareholders to the extremely sound, even if somewhat drastic way, in which the accounts have been framed. It will be observed that this year the unrealized stock of diamonds is brought into reserve instead of being used for calculating the profits available for distribution, and the floating stock of mining stores has been written off. Had the course usually adopted in ordinary and normal times been followed, a profit for the year of 17s. 6d. per deferred share would have been disclosed. Under these circumstances the directors feel that they are not called upon to defend the declaration of a 10s. dividend in December last.

Since then, however, as already stated, the reports on the condition of the diamond market led the directors to believe that a total stagnation was within the bounds of possibility, and they felt it

was incumbent on them to make the company independent of temporary depressions, and they reluctantly, but in the permanent interest of the company, postponed payment of the dividend. Shareholders will readily realize that a narrow limit to the cash resources of the company might have necessitated diamonds being forced on an unwilling market, and thus converted what the directors believe to be a temporary inconvenience into a permanent injury to the diamond trade. Through the action of the directors in delaying payment of the dividend, the company starts its new financial year with an amount of fully £400,000, as will appear from accounts, and, in addition, it commands the proceeds resulting from the delivery of its production for the first four months of the current financial year to the Diamond Syndicate. The policy pursued by your directors enabled and justified the Government in coming to the aid of the diamond industry in the manner and to the extent set out in the circular. The action of the Government calls for the hearty appreciation of the shareholders.

Directors.—Messrs. T. M. Cullinan and P. W. Tracey retire in terms of the company's articles of association, but, being eligible, offer themselves for re-election. Since the close of the financial year T. M. Cullinan, owing to pressure of Parliamentary duties, found it necessary to relinquish the position of managing director, and P. Ross Frames has been appointed in his stead.

Auditors.—The auditors, Howard Pim, and the firm of Alexander Aiken & Carter, retire, but offer themselves for re-election. You will be asked to fix the remuneration for the past audit and appoint auditors for the ensuing year.

Management.—It is with great pleasure that the directors record their profound appreciation of the services of W. McHardy, the general manager, and his staff. The thanks of the directors are expressed to T. Edington and W. M. Chalmers, the secretary and accountant, at the head office, and their respective staff, as also to the diamond department under J. Ehlert; the mine secretary, J. L. Locke; the mine accountant, M. S. Knowles, and their staffs.

(Signed) T. M. CULLINAN, Chairman.
A. WAGNER, P. ROSS FRAMES, P. W. TRACEY, J. I. HOFFMANN, A. LANGEBRINK, E. BRAYSHAW, CHAS. JEROME, JOHN JOLLY, W. H. DAWE, P. DREYFUS, Directors.

Text of the Bill to Forbid Misrepresentation of Merchandise.

ALBANY, N. Y., Feb. 26.—Following is the text of the Grady bill forbidding misrepresentation in the sale of merchandise.

AN ACT TO AMEND CHAPTER 4 AND CHAPTER 9 OF TITLE 15 OF THE PENAL CODE, BY ADDING NEW SECTIONS THERETO, RELATIVE TO FALSE AND FRAUDULENT REPRESENTATIONS OF SALES.

The People of the State of New York, represented in Senate and Assembly, do enact as follows:

Section 1. Chapter 4 of Title 15 of the Penal Code is hereby amended by adding thereto the following:

Sec. 529-a. Any manufacturer, dealer, or other person, who knowingly receives any money or other thing of value, or who causes, directs or permits an agent or employe to receive money or other thing of value, in exchange or in payment for any article of food, drink, confectionery, jewelry or other merchandise, which is of inferior quality or of less value, or composed of different materials than it is represented or claimed to be by such manufacturer, dealer, or other person, shall be deemed to have obtained such money or other thing of value by misrepresentation and fraud and is guilty of larceny.

Sec. 2. Chapter 9 of Title 15 of the Penal Code is hereby amended by adding thereto the following:

Sec. 585-b. Any person who manufactures, offers or exposes for sale in any factory, warehouse, wholesale or retail store, or other place, any article of food, drink, confectionery, jewelry or other merchandise, represented or claimed by such manufacturer, dealer or other person, or by any agent or employe of such manufacturer, dealer or other person, to be made or composed of other or different materials or substances, or of materials or substances of better quality or greater value, than such article is actually made or composed of, shall be deemed to have so manufactured or exposed for sale, such article of food, drink, confectionery, jewelry or other merchandise, with intent to defraud and is guilty of a misdemeanor.

Sec. 3. This act shall be in full force and effect on and after the first day of September, 1908.

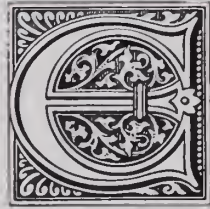

GNTERPRISING and successful jewelers everywhere are pushing the sale of some individual line of watches which they believe to be superior to all others, and upon which they can also make a satisfactory and justifiable profit.

This explains the growing demand for **ILLINOIS WATCHES**, in 0, 12, 16 and 18 sizes, by increasing numbers of leading jewelers throughout the United States.

If you are not familiar with the superior quality of—and advantages gained by handling—Illinois Watches, it will mean reputation and dollars for you to investigate.

Every one fully guaranteed.
Price List sent on application.

ILLINOIS WATCH COMPANY
SPRINGFIELD



Western Office:
501 HEYWORTH BLDG., 42 E. Madison St.,
CHICAGO.

Telephone:
5125 CENTRAL,
CHICAGO.

VOL. LVI.

CHICAGO, WEDNESDAY, MARCH 4, 1908.

No. 5.

Chicago Notes.

George Weidig has returned from a trip to the northwest.

S. C. Eppenstein and wife have returned from Hot Springs, Ark.

James H. Ramsey, Aledo, Ill., was among the buyers here last week.

"Dan" Axman is no longer connected with the J. D. Bergen Co.

George Becker, of Becker & Ramage, La Salle, Ill., was a visitor here last week.

M. J. Straus, of Hammel, Riglander & Co., called on his friends in the local trade last week.

C. H. Knights, accompanied by his wife, left last week, for a month's trip to Florida and Cuba.

Louis R. Millar, representing J. W. Foringer in the south, is back after a six weeks' trip.

W. P. Wincher, 101 Washington St., was here last week for handling objectionable postal cards.

E. Schwartz, of E. Schwartz & Co., has completed a two weeks' term on a jury in the Municipal Court.

Howard Ringgold is now connected with the Chicago office of Leon Hirsch in the Heyworth building.

A. Weidman, representing the Hamilton Watch Co., stopped over in this city, last week, on his way west.

A. Garon, of Garon Bros., Duluth, Minn., stopped over here, last week, on his way east, on a pleasure trip.

W. H. Bradley, of the J. D. Bergen Co., accompanied by Mrs. Bradley, paid a visit to the western office of the company last week.

The assets of the bankrupt National Jewelry Co., whose liabilities were \$24,000, have been sold to E. S. Pike, a real estate dealer, for \$1,400.

W. J. Gamm, Madison, Wis., was here, last week. Mr. Gamm will make a southern pleasure trip of four weeks' duration before returning home.

Will F. Juergens, of the Juergens & Andersen Co., returned from French Lick Springs, last week, after previously undergoing an operation.

Kelsey & Wienecki, opticians, have removed from room 301 to room 307, Chicago Savings Bank building, where they occupy much larger quarters than formerly.

C. D. Peacock has installed a set of chimes at the outside of his store. These strike the quarter, half and full hour and

attract a good deal of favorable comment.

Carl Fasch, assistant to Louis Bruns, in the Denver office of the Juergens & Andersen Co., is now associated with Ferdinand Hotz, diamond dealer, in the Stewart building.

J. D. Hawthorne, Kearney, Nebr., was united in marriage, Feb. 6, at Peru, Ill., to Miss Clara F. Gillmann, of that town. Mr. and Mrs. Hawthorne were in this city, last week.

John H. C. Baumgarten died last Thursday, aged 73 years, and was buried last Sunday at Graceland Cemetery. Mr. Baumgarten was the father of Edwin Baumgarten, traveler for M. F. Barger & Co.

Frank C. Schulenberg, of Schulenberg Bros., manufacturing jewelers of Milwaukee, Wis., was united in marriage last Saturday to Miss L. Greiner. Alfred H. Schulenberg, brother of the groom, was best man.

Among the out-of-town jewelers here, last week, not mentioned elsewhere were: A. I. Shapira, of A. I. Shapira & Bro., St. Paul, Minn.; A. R. Staufenbeil, Dubuque, Ia.; H. E. Scattergood, Hillsdale, Mich.; Walter W. Stitt, representing Lincoln H. Hall, Trinidad; Col. M. Howard, of Wolf & Howard, Rochester, Ind.

The creditors of the National Jewelry Co., which was adjudicated bankrupt, Feb. 6, have been notified by Referee Frank L. Wean, that the first meeting will be held in room 637, Monadnock Block, March 5, at 10:30 A. M., at which time all those having claims may attend, present their claims, appoint a trustee and examine the bankrupt.

C. H. Knights & Co. have applied for incorporation papers. Mr. Knights is on a southern trip, and the details of the incorporation will not be completed until his return. Fred G. Thearle, the present "Co.," said the new corporation will have a paid-up capital of \$125,000, and would be known as C. H. Knights-Thearle Co. Mr. Thearle stated that the incorporation would permit several heads of departments becoming stockholders in the concern.

An involuntary petition in bankruptcy has been filed against the Madsen-Steele Co., a jewelry mail order concern in the Masonic Temple, who failed three years ago. The petitioning creditors are: The E. L. Spencer Co., \$850; B. A. Ballou & Co., and the Attleboro Chain Co., \$50. The petitioners allege that the corporation committed an act of bankruptcy by paying some creditors

while insolvent, that it had asked for an extension of credit, and that at present some creditors had entered suit against the corporation, and that on order to conserve the estate, a receiver was necessary. The corporation, and that in order to conserve it asked for an extension, that the liabilities were \$29,364, with assets of \$43,595.

Sigmund Ascher, a retail jeweler at 444 Milwaukee Ave., who recently sought to compromise with his creditors on a basis of 50 cents on the dollar, and who failed to secure their consent, has filed an involuntary petition in bankruptcy with liabilities of \$3,832, and assets of \$3,214. Of the latter the merchandise is estimated at \$2,061, of which \$465 worth is claimed exempt. The creditors from \$50 to \$100 are: Despres, Bridges & Noel, J. Bulova, Rockford Watch Co., and Emil Braude & Bro. Between \$100 and \$200, Otto Young & Co., Sproehnl & Co., and Hirsch & Oppenheimer. Between \$200 and \$300, Fred Blauer & Co., and Sabsevitz Bros. From \$300 to \$400, Eliassof Bros & Co., A. Hirsch & Co. The largest creditors are: L. Witsenhausen, \$1,262, and Ingomar Goldsmith & Bro., \$900.

Toledo.

Clinton & Close have eliminated their jewelry department, and will hereafter confine their business to women's garments and similar articles.

New members of the Toledo Chamber of Commerce among Toledo jewelers are: William Walcott, E. D. Gould, John Swigart, J. Prochaska, Robt. Nelson, A. J. Heesen, C. K. Merrill and L. Beckman.

J. W. Flowers, formerly a well-known jeweler here, has purchased the patents for manufacturing a truck scale and will hereafter devote his time to this business. Mr. Flowers was for 10 years watchmaker for J. J. Freeman & Co., for a number of years watchmaker for J. G. Kapp, and later owned and operated a store on Adams St. For some years past he has acted as secretary of the Toledo Chamber of Commerce, but resigned that position to take up the truck scale proposition.

Philip Koch, owner of a jewelry store in New Albany, Ind., attempted to commit suicide at his home a short time ago. It is believed that he will recover.

A Sample Opinion of Our Method

☞ Read the Letter Under the Picture ☞



STORE OF CALVIN K. CLAUER, SOUTH BEND, IND.

Two Stores—105 S. Michigan St., South Bend, and 517 S. Main St., Elkhart, Ind.

South Bend and Elkhart, Ind., Jan. 6, 1908.

The Arnstine Bros. Co., Cleveland, Ohio.

Gentlemen:—In reply to your favor regarding testimony for your Catalogue will say that as a medium for advertising, we believe your system very beneficial and elevating in gaining a high opinion of the trade, as a first-class jeweler and by having our name brought up and spoken of in the store and at home.

Having the merchandise to deliver for certain illustrations, when asked for, was very satisfactory.

We will be glad to interview your proposition for 1908 when you have it ready.

Yours truly,
CALVIN K. CLAUER.

We are now furnishing our Catalogs to a large number of Retail Jewelers, located in nearly every State in the Union, some of them for eight years in succession, increasing their business, and giving their stores a prestige not otherwise obtainable.

Write us at once for samples and particulars FREE

Our representatives visit nearly every State in the Union. If you are interested, and will notify us, our representative will take pleasure in calling on you and explaining our method.

THE ARNSTINE BROS. COMPANY

Originators of Our Exclusive Catalog Method for the Retail Jeweler

CLEVELAND, OHIO

Cincinnati.

John Selbert, Frankfort, Ky., spent a few days in this city last week on business.

Joseph Phillips, of the Sterling Glass Co., was in New York on business last week.

A. J. Augustin, of the Dennison Mfg. Co., is in Columbus, O., this week on business.

Jonas Wise, of Frohman & Co., left this week on his regular business trip to the north.

A. C. Brodfuehrer, Louisville, Ky., was here last week attending the Bowlers' Convention.

George Detmering, of the M. Schwab Jewelry Co., is calling on the Indiana trade this week.

The Cincinnati Watch Case Repair Co. is remodeling its factory and installing new machinery.

Charles Jacot, manager for Friedrich Spiedel, Germany, made his annual visit to his city last week.

Herbert Oskamp, of the Oskamp Jewelry Co., has been kept away from business by an attack of grippe.

William Pflueger and J. B. Osthoff, of Joseph Noterman & Co., have left on their respective trips west.

Mr. Perry, superintendent of the Hamilton Watch Co., called on the trade here during the past week.

Henry Detmering, superintendent of the Dueber Watch Case Mfg. Co., was here last week visiting friends.

J. C. Daller, Sr., manager of the Clemens-Oskamp Co., has been unable to attend to business on account of illness.

Joseph Voss, Jr., of Joseph S. Voss & Sons, left last week on an extended business trip through the southwest.

During the Scottish Rite convention, held here last week, the 32d degree was conferred upon David Gradison, Arcade.

C. L. Mellott, Woodsfield, O., last week stopped here on his way to California, where he will remain about two months.

W. L. Fredeking, Hinton, W. Va., has opened a new store at Russell, Ky., for which he bought his opening stock here last week.

W. L. Fredeking, Hinton, W. Va., bought the stock here for his new jewelry and repair business which he has just opened at Russell, Ky.

E. W. Ledman, of Samuel E. Ledman & Son, Louisville, Ky., was here last week appearing as a champion bowler during the contest held in this city.

Loring Andrews, of the Loring Andrews Co., was in New York last week as a guest at the wedding of the Duc de Chaulnes and Miss Theodora Shonts.

Lee Loeb, of Herman & Loeb, has just returned from a 10 weeks' business trip west. Clarence Loeb, of this house, visits the trade in Ohio this week.

E. G. Frankenstein was married, Feb. 24, to Miss Bess Dreifus, of this city. They are now visiting eastern cities, after which they will return to Cincinnati to reside.

The Cincinnati Wholesale Jewelers & Manufacturers' Association was incorporated last week by A. G. Schwab, Charles A. Noeting, Louis H. Albert, Eli Gutman and Joseph Noterman.

J. H. Johannot, formerly with Krantz.

Smith & Co. at Honesdale, Pa., has taken a position as traveling salesman with the Sterling Glass Co., and will have for his territory the middle west.

Gustave Adolph Wagner, eldest son of Emil Wagner, a jeweler of Freeman Ave., died Feb. 20 at the age of 35 years, at his home on Freeman Ave. He had very recently returned from California, whither he had gone to benefit his health.

C. W. Lucius, of the Frank Herschede Co., and his wife, celebrated their 25th wedding anniversary last week. Among the many beautiful remembrances received was a handsome bunch of 25 American beauty roses, the gift of the employes of the company.

Among those attending the Scottish Rite convention in this city last week were: H. A. Bedel, Jackson, O.; Major Frank Henn, Chillicothe, O.; C. A. Gossard, Washington Court House, O.; O. G. Kelley, Eaton, O.; Charles H. Blume, Marietta, O.

William Deters, watchmaker for William Preuer, and wife, celebrated their 32d wedding anniversary Feb. 9 with a large reception at their home on Laclède Ave., Price Hill. The occasion was very enjoyable and many handsome gifts were presented the happy couple.

D. Gruen, of D. Gruen, Sons & Co., sailed Feb. 29 on the *Princess Irene* for the Mediterranean. He will spend the Summer months in Madretsch, Switzerland, at the company's factory. George Gruen, of this company, is in Columbus, O., this week on business pertaining to legislative matters.

At an early hour one morning last week burglars smashed the large window in the front door of Louis Rosin's novelty store at 4 E. Pearl St., and stole about \$50 worth of stock. The loot consisted of stick pins, cheap watches, all kinds of jewelry and opera glasses. Later in the day two men were arrested at Race and Commerce Sts. who had some of the stolen goods. The prisoners are Louis West and Joseph Leonard.

A colored man giving his name as Sam Jones was arrested Feb. 27 on a charge of having robbed the show window of the Gilsey store of \$300 worth of jewelry one night last week. He was before the police court Feb. 28 and bound over to the Grand Jury. When arrested he was pawning the stolen goods at a Central Ave. pawnshop. Members of the Gilsey firm were summoned and identified the articles as theirs. The window had been broken by a brick.

Out-of-town jewelers who were in this city last week purchasing stock, included: F. C. Taylor, Carlisle, Ky.; Fred. J. H. Schell, Xenia, O.; O. Heidingsfeld, Greenfield, O.; A. P. Humphreys, Bellefontaine, O.; E. F. Randolph, of Randolph & Mutendorf, Williamson, W. Va.; Joseph Meyer, Harrison, O.; G. O. Woodcock, New Martinsville, W. Va.; Charles Diefenbach, Jr., Hamilton, O.; Mr. Sanders, with O. V. Neal, Parkersburg, W. Va.; Walter G. Wheaton, Dayton, O.; S. L. Sherwood, Ewing, Ky.

Julius Levy, engaged in a small jewelry business at 341 W. 5th St., was last week the victim of two robbers, who had decoyed him to a lonely place on Charles St. by

means of a letter. The letter asked the jeweler to call at an address given, as the writer wished to purchase certain trinkets in the jewelry line. Mr. Levy started for the house designated in the letter, and upon nearing the place was attacked by the two men, who demanded his money. Though he had considerable money on him at the time he made his escape with no loss.

Cleveland.

Albert M. Dueber, of the Dueber-Hampden Watch Works, was in this city last week.

The unexpected appearance of James Logan, a jeweler of St. Clair Ave., prevented two men rifling the window of his store after they had smashed in his large plate glass front last week. Mr. Logan, hearing the crash, ran forward from the rear of his store in time to frighten away the thieves.

Coming down to his Superior Ave. store last Friday morning Harry Goldberg found a large round hole smashed in his plate glass window and all the goods within reach missing. Out of several hundred dollars worth of jewelry stolen the police have at this writing recovered one gold-filled bracelet. This is Mr. Goldberg's third experience of the kind this Winter.

Whether as a result of the "golden rule" tendencies of the Chief of Police and the two new police court judges, or because of the number of unemployed being unusually large for this time of the year, there is just now an epidemic of window smashing, burglary, etc. Jewelers' window displays are running largely to plated silverware, art goods and cut glass, the more valuable articles being locked up in their safes at night.

Capt. R. E. Burdick, of the Bowler & Burdick Co., is in receipt of a letter from his Amsterdam diamond brokers under date of Feb. 18. They state that the price of rough remains firm and advise that representatives of the De Beers and the Premier Mining companies and of the controlling selling syndicate of London have just signed a new agreement. This recent understanding, they say, will serve to draw even closer together those in control of the diamond market, and is a further guarantee of the stability of prices.

Chas. Leach, collector of customs, has lost in his fight to have the Cassie Chadwick jewels he seized in New York sold for the benefit of the woman's creditors. The Supreme Court of the United States has dismissed the appeal from a decision of the Circuit Court of Appeals of the Sixth District, which ordered a return of the jewels. According to the district attorney's office the jewels will now be returned to J. W. Friend, Pittsburg, who claimed possession. The jewels, it is alleged, had been smuggled into this country from Europe.

In a recent fire in Colorado Springs, Colo., the Ashby Jewelry Co. sustained a loss of about \$5,000, fully insured.

B. G. Gustafson, Lawrence, Kans., has been awarded the contract to repair the time recording clock in the Lawrence post-office.

The Only Manufacturers in the Line Selling Only to Retail Jewelers Direct

SOLD WITH
PROFIT BY
THE RETAIL
JEWELER.

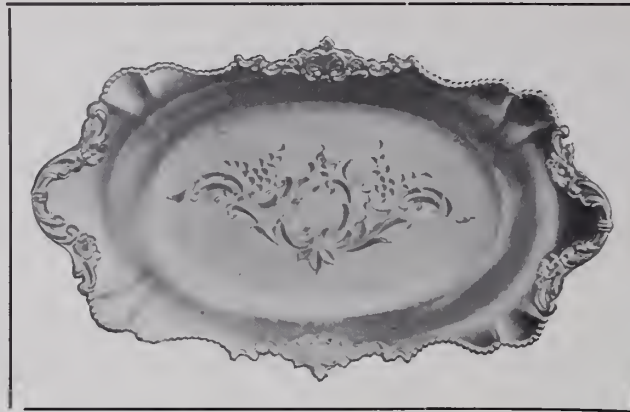

IF YOU HAVEN'T
SEEN OUR
LINE, WRITE
AND ONE OF
OUR SALES-
MEN WILL
CALL.

Rockford Silver Plate Co. ROCKFORD, ILL.

“Stand By Those Who Stand By You”

WE PROTECT EVERY RETAILER OF ROCKFORD GOODS

A Wonderful Discovery in Jewelry!!

HAT PINS MADE FROM GENUINE ROSEBUDS

Fresh cut rosebuds are placed in a solution which deposits a coat of metal on the buds. The form, with the delicate veins and tracings of the leaves, is retained.

AS IN
NATURE
NO TWO
ARE ALIKE
—
ROSE GOLD
FINISH
—
SOLD ONLY
TO
RETAIL
JEWELERS



THESE
HAT PINS
CAN BE
RETAILED
AT FROM
\$2.00
TO
\$5.00
WHEN
IT IS
EXPLAINED
WHAT
THEY ARE

HAT PINS, C-656, PER DOZEN, \$12.00 NET.

SEND ORDERS TO

LAPP & FLERSHEM, Wholesale Jewelers, CHICAGO, ILL.

Los Angeles.

E. Gerson moved, March 1, to his new store at 545 S. Broadway.

F. C. Gardner, formerly located on Main St., has moved to 222 W. 1st St.

A. J. Wipperman, Idaho Falls, Idaho, visited Los Angeles the past week.

Philip Klein, of this city, has opened a branch store in San Francisco, Cal.

Percy H. Greer, of this city, is making a creditors' sale for B. Lissner, Oakland, Cal.

H. H. Adams, San Francisco manager for the Gorham Co., was here last week on his way home from New York.

F. A. Perkins, formerly with T. Besbeck, 224 S. Spring St., has joined the forces of O. Lipman, manager of the workshop, 324 S. Broadway.

Geo. E. Feagans, Joliet, Ill., arrived here last Saturday to attend the annual meeting of the stockholders of the Brock & Feagans Co. He will remain but a short time.

Among the jewelers from neighboring towns who were here recently, were: L. E. Vaughn, Oxnard; S. P. Johnson, Glenora; Elsie Wynne, Azusa, and F. E. Wolfarth, Covina.

Robert A. McMullen, president of the Southwest Turquoise Co., after a visit of a week or two here, has gone to Arizona for a short time to look after the turquoise mines of his company there.

Ed. Turner, of the E. W. Reynolds Co., is out again making a trip to San Diego and through the southern part of the State. A. E. Baranger, of the same company, is making a trip through the north.

Another hearing of the case of Frank J. Blumkin, before the referee in bankruptcy, will be held on March 5. He denies that he pawned diamonds from his stock. An attempt will be made at the next hearing to get at the facts about the alleged mysterious disappearance of a large portion of his supposed assets.

Brock & Feagans have just made for the Redondo Electric Railway Co. four fine heavy gold medals to be given by the company to Conductor John C. Green, motorman H. E. Aiken and R. O. Williams and R. J. Gillespie "for conspicuous bravery." On the night of Jan. 11 a suburban car, of which Green and Aiken were in charge, and on which Williams and Gillespie were passengers, was held up by a robber. The robber, with two revolvers in his hands, ordered Green to put up his hands. Williams, who was behind the bandit, threw his arm around the bandit's neck and, at the same time, with the other hand, struck one of the bandit's hands upward. Aiken knocked the bandit's other hand upward and shot him three times, killing him almost instantly. Aiken and Gillespie also rushed to the conductor's aid at the risk of their lives.

The incorporation of the business of Brigden & Pederson, under the style of the Brigden & Pederson Co., which was noted in THE CIRCULAR—WEEKLY last week, is the outcome of the meeting of creditors held Feb. 6, at which time a statement was presented showing the concern's assets to amount to about \$50,561, the total liabilities \$41,698, leaving a nominal surplus of \$7,863. As the partners had no property outside

of the firm's assets and the business was in such an excellent condition that it was thought necessary that it should be continued without interruption, the corporation was then decided upon. The board of directors consists of five members, three of whom are selected by the creditors, the other two being Messrs. Brigden and Pederson. The capital stock of the corporation was issued to the former partners, who transferred it in pledge to the three members of the board representing the creditors, and the latter incur no stockholders liability by the arrangement. An endeavor is now being made to have all of the creditors assent to this plan to prevent any action in the way of bankruptcy proceedings or suits. As the business is being continued the net proceeds were distributed to creditors pro rata, Messrs. Brigden and Pederson running the business at nominal salaries and the creditors on the directorate serving without pay. It is expected that by this means about 50 per cent. of the indebtedness will be paid within a year, and at the end of that time there will be an excellent prospect of realizing the balance in full. The creditors' committee in charge of the assets are F. R. James, of the J. P. Trafton Co.; H. B. Lewis, E. W. Reynolds Co., and A. C. Ingram, of S. Meyer & Co.

Indianapolis.

W. J. Hoffman, of Hoffman & Lauer, is recovering from a severe attack of la grippe.

Julius C. Walk & Son, as members of the Retail Merchants' Association, have indorsed the proposition to consolidate the two local telephone companies.

James M. Morris, treasurer of the Fidelity Watch Co., has been named as a member of the grand jury that will investigate the wholesale charges of graft in county offices.

City authorities are making a test of the city ordinance requiring a fee of \$25 a day for the temporary operation of branch stores. A woman who has been representing an eastern concern and using the sample rooms of a local hotel as a salesroom, was placed under arrest. The case is to be appealed to a higher court.

The committee having the second annual automobile show in charge, which will be held March 23-28, has named the following local jewelers as timers for the hill-climbing contest, March 24: Carl Walk, of Julius C. Walk & Son; George S. Kern, Gus Craft, of A. P. Craft & Co.; Horace A. Comstock and A. W. Gray, of Gray, Gribben & Gray.

Another effort will be made to have the Indianapolis Retail Jewelers' Association affiliate with the State body. Some of the members of the local organization were already members of the State body, so it was decided not to join as an organization until the matter had been discussed further. It is believed that within a short time the State association will be increased by the 29 members of the local association.

Ralph K. Worden, posing as a representative of the "W. A. Rogers' Silver Co.," was arrested last week after he had attempted to appoint Detective James F. Quigly, of the local force a branch manager. Worden's scheme was to appoint a manager in each

city and collect as high a cash bond as possible. He represented that he had a coupon system through which laundries were to be induced to give away a set of silver for every \$25 worth of work done. From letters found among his belongings it is evident that Worden operated in a dozen or more cities. A woman found in his company was arrested, but later was released.

Kansas City.

A. J. Levin has moved his stock from 718½ Walnut St. to 934 Main St.

H. I. Player is this week taking an active part in the six-day walking match in the Convention Hall.

W. G. Lytle, with the Bliss Jewelry Co., Atchison, Kans., was in Kansas City last week on a vacation trip.

Nettie Quick, stenographer for the Edwards & Sloane Jewelry Co., is confined to her home with tonsillitis.

Sam Bloom, with the Meyer Jewelry Co., was in the house a couple of days last week, but is again in his territory.

L. T. McHugh, from Sheridan, Mo., is in the city, taking a course in engraving at the Kansas City Engraving School.

C. P. Kionka, of Kionka & Kionka, has returned from a trip through Iowa, and will leave for his Spring trip through Texas next week.

R. A. Helmer, South Auburn, Nebr., passed through this city last week, on his way to Olathe, Kans., where he paid a visit to relatives.

Jos. H. Talbert, Talbert Jewelry Co., Kingman, Kans., has just announced the marriage of his daughter Jessie, Feb. 18, to Dr. G. E. Burket.

Paul Preston, traveler for the Edwards & Sloane Jewelry Co. in Kansas and Oklahoma, paid the house a visit, last week, and left for his territory Sunday.

Bernard Fricke, watchmaker for the Meyer Jewelry Co., served a term on the jury last week, and Fred Doubler, with the same house, is doing the same thing this week.

The house force of the Edwards & Sloane Jewelry Co. begins this week to take its vacation. Every week between this and June there will be one or more of the force absent.

Patrick Larkin, with the Hassig & Krieke Watch & Jewelry Co., has just been indorsed by the Democrats of the Sixth Ward of this city for member of the lower house of the city council.

Kionka & Kionka have moved to 207-08 Missouri building, on the same floor of the same building in which they have been located. They now have more floor space than in their old quarters.

The following jewelers called on the local trade, last week: M. C. Fox, Russell, Kans.; T. S. Mendenhall, Burr Oak, Kans.; Mrs. J. W. Oxley, Browning, Mo.; C. A. Clement, Springfield, Mo.; J. M. Earp, Lamar, Mo.; W. J. Lewis, Topeka, Kans.; Stuart Mitchell, Oklahoma City, Okla.; L. J. Harris, Corder, Mo.; Mr. Thistlethwaite, with C. E. Range, Trenton, Mo.; A. L. Wilson, Newton, Kans.; Mr. Marks, with A. Marks, Lawrence, Kans.; Leslie Burkland, Moberly, Mo.; E. Freeman, Paola, Kans.; J. O. Stett, Paola, Kans.

New Silk Cord, with Needle, for Stringing Beads

This Silk Cord is Strong and Durable, and made in two sizes, small and medium

No. D7. Small size.	per doz. cards,	\$0.75
" D7. Medium size.	" " "	.75
" D7. Assorted sizes.	" " "	.75

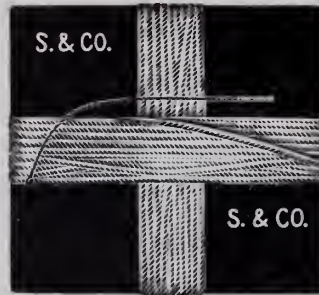

A twisted metal needle, one and a half inches long, is attached to each cord, making it very easy to string beads.

Six Feet of Cord to Each Card.

SWARTCHILD & COMPANY

If you have not a copy of our double-sized 440-page Catalogue, write at once. Sent gratis upon application.

Heyworth Building, Chicago

THE LARGEST EXCLUSIVE JEWELERS' SUPPLY HOUSE IN THE WORLD

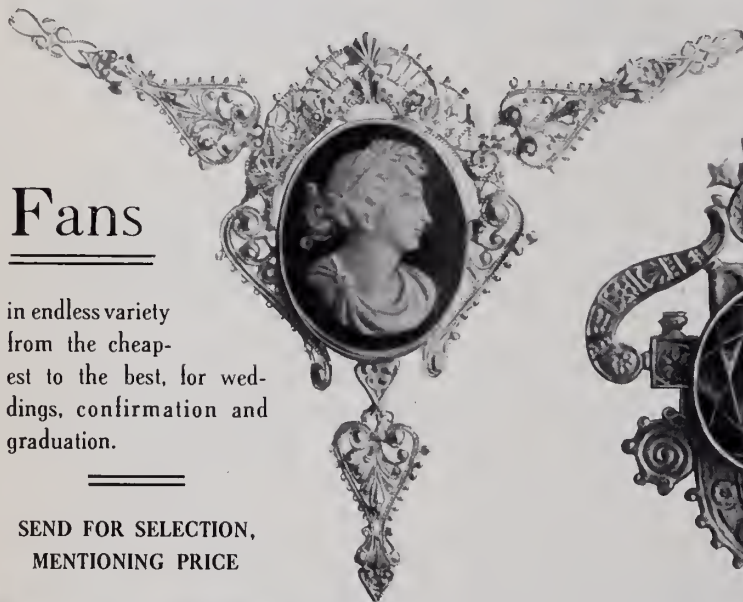

Fans

in endless variety from the cheapest to the best, for weddings, confirmation and graduation.

SEND FOR SELECTION,
MENTIONING PRICE

Novelties for Easter



in Necklaces, Buckles, Belt Pins, Brooches, Hat Pins, Collars, in sterling silver and gold plated, set with semi-precious and imitation stones: lapis, coral, amethyst, topaz, etc. Also an extensive line of Cameo Jewelry.

LEWY & COHEN

IMPORTERS

530 Broadway Cor. Spring St.
NEW YORK

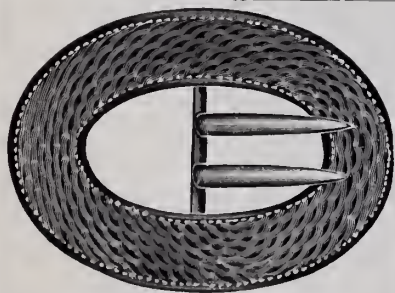

Engine Turned Buckles and Belt Pins

4 Styles . \$9.00 a Doz.

Silver, Gilt, Oxidized or
Gun Metal Finishes

Quality Guaranteed

(Other Styles up to \$18.00 a Doz.)

Artistic, But Inexpensive

PRODUCTS OF

The "Apollo Studios"

WILL INCREASE YOUR
SPRING SALES

Bernard Rice's Sons

PROPRIETORS

544 BROADWAY

Works and Studios 4-6 Marion St.
205-207 Lafayette St. NEW YORK



No. 471—ELECTROLIER

(Patent applied for)

Height, 20 in.—2 Lights
Copper Bound Leaded Glass
Shade, 17 in. Diam.

PRICE, \$16.00

St. Louis.

TRADE CONDITIONS.

February, although not a month of phenomenal business activity in any line of trade, seems to have been fairly good in the jewelry trade. Dealers and jobbers report that they have held their own and in some cases the month was from five to 10 per cent. better than the corresponding month of the previous year.

Foreman Nacke, of the E. Maritz Jewelry Mfg. Co., is suffering from la grippe. W. D. Armstrong, of the Armstrong Jewelry Co., Brownwood, Tex., was one of the week's visitors to the trade.

The fiscal year of the Eisenstadt Mfg. Co. closed on the last of February. The annual meeting, however, will not be held until June.

The retail jewelers of East St. Louis, Ill., are forming an association and have effected a preliminary organization. They will meet to-morrow to elect permanent officers and to adopt a constitution and by-laws.

State Auditor Wilder, who is a member of a large jewelry firm in Jefferson City, Mo., has announced that he will not be a candidate for re-election to his present office. Mr. Wilder declares that he will devote his whole attention to his business.

Marcel Acker, 1939 Utah St., was a member of the jury which last week returned a verdict of guilty in the case of Daniel Naughton, assistant clerk of the House of Delegates, who was brought back from New Orleans recently on an indictment for accessory after the fact of bribery.

Among the out-of-town jewelers who visited St. Louis last week were the following: W. J. Urbani, Vandalia, Ill.; George L. Edwards, of Edwards & Son, Kansas City, Mo.; S. G. Parker, Newport, Ark.; Gene Thomas, Thomas J. House, Kirksville, Mo.; William R. Davis, Jr., Springfield, Mo.; S. O. Harvell, Harvell Jewelry Co., Litchfield, Ill.; William Shulte, Breese, Ill.; J. T. Brunner, Brashear, Mo.; Al Gerber, Edwardsville, Ill.; O. L. Davis, New Madrid, Mo.

Milwaukee.

Thomas C. Weston has been elected trustee of the bankrupt estate of M. M. Huck, Kenosha, Wis.

Franklin Thomson, temporary secretary of the Badger State Optical Society, which formed a temporary organization in Milwaukee, two weeks ago, says that there will be 100 to 150 members by the time of the first business meeting, which will be held July 9-10.

A window in the store of C. J. Dewey, at 232 West Water St., jewelry and notions, was broken, last week. James Howard, a former school teacher, 52 years old, broke the plate glass, it is claimed, with a stone and cleared out the show window. A passer-by called the police and Howard was caught within a few minutes. All the goods were recovered.

A "civic beauty" craze that struck Milwaukee, and which was endorsed by many jewelers, has proved a boomerang, some think. An order was issued, last week, to all owners of over-hanging advertising signs to take them down within 48 hours. Lit-

tle did jewelers think, when they figuratively patted the Board of Public Works on the back that the clocks in front of jewelry stores would be ordered down, but such an order was given. The Jewelers' Club then held a meeting and made an organized effort to have the order rescinded in so far as the clocks are concerned. The jewelers agreed to take down all advertising from the clocks, but want the clocks left alone. R. Bloedel, on Grand Ave., was most emphatic in his opposition. The big clock in front of his store has stood for more than 25 years. The C. Preusser Co., Mason and East Water Sts.; Alsted & Kasten Co., Wisconsin and Milwaukee Sts., and nearly every downtown jewelry house, has a street clock. The jewelers may obtain injunctions, if necessary, to protect the clocks.

Denver.

Wm. P. Jones, Fort Luyston, Colo., visited this city, last week.

W. W. Singleton, Lafayette, Colo., was in this city, last week, buying stock.

Louis Hahn is now connected with the firm of Joseph I. Schwartz, as a salesman.

W. E. Payne, Boulder, Colo., was in this city, for a few days, last week, on a business trip.

L. Egholm, a jeweler of Yampa, Colo., suffered a severe loss, last week, his home having been entirely destroyed by fire.

Thieves, Feb. 24, broke the plate glass window of a local jewelry store and got away with two trays of diamonds, valued at \$30,000.

C. H. Patch, of the Edward Lehman Jewelry Co., will leave, the middle of this week, for a trip through Wyoming and Nebraska.

R. E. Hawkins, of the Edward Lehman Jewelry Co., left, last week, on an extended trip through the southern and eastern part of the State.

Hugo Hill, who has been with the Boyd Park Jewelry Co., of this city, for the past four or five years, has resigned and is now with a concern in Cleveland, O.

Joseph I. Schwartz, the local jeweler whose store windows were badly scratched by vandals, has put in a new plate glass front. Thus far no arrests have been made.

The firm of M. Myers & Co., formerly in business at 1519 Stout St., recently dissolved and J. Buchhalter, the son of M. Buchhalter, of the old firm, is continuing in business at the old address under his own name. Mr. Buchhalter is a young man about 18 years of age.

Harry L. Kortz is opening a new store at 970 15th St., and it will be exceptionally attractive. The fixtures are of oak, and there are two large plate glass windows. The store was bought last April, but the former occupants only recently moved out. The store is to be run by Mrs. Kortz and Mr. Kortz's brother-in-law, Mr. Klinger, under the name of Klinger & Co., under the supervision of Mr. Kortz.

On the evening of Feb. 19, the Jewelry Workers' Union of America, local No. 7, gave a ball at Richmond Hall, 1646 California St. The committees were as follows: Arrangements—P. Fruh, chairman; W. E. Goward, K. Lidholm, R. Colvin, G. A. Ehret, Paul Otto and W. Hurlle. Re-

ception—W. E. Goward chairman; G. A. Ehret and P. Fruh. Floor—K. Lidholm, chairman; E. J. Simpson and Daniel Conway. The affair was largely attended.

Detroit.

L. L. Johnson and wife, Tawas City, were here, recently.

C. H. Miner, Chocotah, visited friends here, recently.

Leonard Cooper, Oxford, Mich., was here recently, on legal business.

Robert Traub is the proud papa of a baby girl, which arrived last week.

F. L. Showerman, Ypsilanti, was a purchaser in town a few days ago.

W. T. Savage, Ubly, was looking at optical goods when in town last week.

B. Hawkins, with F. A. Jorexel, returned, Friday, from a trip through Michigan.

George Johnston, of the Johnston Optical Co., was in Chicago part of last week.

W. H. Moreton, with Noack & Gorenflo, has joined the new cavalry troop of militia just formed.

George Schaffner, who recently bought out E. D. Trebilcock's store at 324 Woodward Ave., is inventorying and will add largely to the stock.

Traub Bros. & Co. were sufferers in a fire, last week, which narrowly escaped being a disastrous one. The fire started in the floor and ran up back of the silver cases built against the wall. The store was filled with smoke in a minute or so and only the prompt work of the employes with hand extinguishers and apparatus, in the store and cellar, prevented a big loss. The damage was about \$100.

The marriage of Frank P. Mathauer, of the wholesale jewelry firm of Mathauer & Koester, 106 Woodward Ave., to Miss Antoinette N. Voelkel was held Wednesday evening last. Mr. Mathauer has been connected with the jewelry business for a number of years. Miss Voelkel was principal of the Monteith school. The wedding trip extends to Washington, D. C., and southern cities and the happy couple will reside, on their return, in a new home now building on Calvert Ave.

The buyers' excursion of the Wholesalers' Association brought many jewelers into Detroit. Besides those mentioned elsewhere, the following visited the wholesale trade: W. F. King, Adrian; C. E. Marvin, Howell; Mrs. E. M. Goette, Orion; E. H. Cressey, Saline; E. J. Potter, Carleton; Mr. Edwards, of Edwards & Adams, Carleton; C. E. Montfort, Utica; William Murphy, Lansing; M. J. Yake, Deckerville; J. J. Campbell, Pigeon; A. F. Crongeyer and A. B. Milkins, Wyandotte. A feature of the Wholesalers' week was a series of noonday luncheons at the Penobscot Inn, at which good speeches were made by merchants and others, the topics bearing upon commercial topics largely. The Wholesalers' transportation bureau has perfected railroad arrangements, which make possible earlier deliveries in a very wide territory and thus broaden the city's wholesale market.

James Fricker & Bro., Americus, Ga., are conducting an auction sale prior to overhauling and making extensive improvements and alterations in their jewelry store.

Minneapolis.

The F. L. Bosworth Co. has installed a system of balconies, so as to gain additional storage room.

Cohen Bros. will be the firm style of the new business soon to be opened at 412 Nicollet Ave., as a removal of the present business of Meyer Cohen & Co., now at 235 Nicollet Ave.

Grant R. Simons, Langford, S. Dak., surprised his many friends in the trade by getting married while in Minneapolis, recently. Mr. and Mrs. Simons went at once to their home in Langford.

The shop goods and tools of Morsman & Feagans, St. Paul, were sold, recently, to B. Ballard, who owns the jewelry repair department in the store of Schuneman & Evans, of that city. The store itself has been leased for a clothing business.

There is an agitation in the city for the removal of overhanging signs and other street incumbrances. As a result of this, a number of merchants along Nicollet Ave. have voluntarily removed signs. Among the jewelers who have done so, are: White & MacNaught, S. Jacobs & Co., the R. G. Winter Jewelry Co., T. V. Moreau, and others.

Omaha.

Miss Margaret Kerr, buyer for A. Mandelberg, has returned from a visit at Indianapolis, Ia.

Miss Ada Porter, formerly with T. L. Combs & Co., has taken a position with Gustafson & Hendrickson.

T. L. Combs attended the convention of the Nebraska State Jewelers' Association, which was held in Lincoln, Nebr., Feb. 27.

R. E. Pitcher, Alma, Nebr.; Dr. Cross, De Witt, Nebr.; M. J. Lebian, Gretna, Nebr., and F. W. Bruning, Bruning, Nebr., were in this city last week, replenishing their stock.

A. L. Haman, chief inspector for the Great Northern, Northern Pacific and C. B. & Q. R. R., with headquarters in St. Paul, Minn., was in Omaha last week, and left for an inspection trip over the B. & M. lines.

Mrs. J. C. Hunt returned to her home in Superior, Nebr., last week, having completed a post-graduate course in optometry in Chicago, Ill. While en route home she stopped off a few days in Omaha, the guest of Mrs. C. L. Shook.

Pacific Northwest

Buhn Bros. are about to close out their jewelry store in Bellingham, Wash.

Frank Cooleage, Athena, Ore., was married last week to Miss Edna Stahl, of Moro, Ore.

Herman Fredell, North Yakima, Wash., has been adjudged a bankrupt; assets, about \$9,000; liabilities, \$11,000.

A. C. Fox, Seattle, Wash., has entered the employ of Burnett Bros. in their Chehalis store, and will attend to the watch repairing and jewel setting.

Desautels & Duggan have been appointed curators of the estate of J. I. Brouillette, Montreal.

San Francisco.

L. C. Koberg, Healdsburg, Cal., is now in San Francisco.

Charles Nelson, Fowler, Cal., is now in San Francisco.

W. T. Harris, Los Angeles, is visiting the trade in San Francisco.

Fred Dorrance, of the Dorrance-Battin Co., has returned from the east.

John A. Hammersmith, of Hammersmith & Co., is on a pleasure trip to Byron Springs, Cal.

Jos. H. Ames has completed the equipment of his new diamond-setting shop in the Kamm building.

Marcus Mayer, of Jos. Mayer & Bro., Seattle, Wash., made a visit to the San Francisco trade last week.

T. Burns, of 1507 Ellis St., has reported to the police the robbery of a five-carat diamond from his store. He has no clue to the robber.

A. Hoffmann is training a race horse which he intends to drive in the races of the San Francisco Driving Club in Golden Gate Park, May 3.

Mr. Daynes, of Daynes & Son, Salt Lake City, spent a day in San Francisco last week on his way home from a visit to southern California.

Hammersmith & Co. are supplying a number of trophies for the automobile show which will be held here in a few weeks. They have just completed a contract for nine Howard clocks, which have been installed in the new Pacific building, at 4th and Market Sts. Their new building at Sutter St. and Grant Ave. is about completed, and they are showing a picture of it in the window of the Van Ness Ave. store.

Pacific Coast Notes.

Mr. Schuler is having an extension put on his store at Fortuna, Cal.

H. B. Crouch, Los Angeles, Cal., was married at Santa Ana, last week.

C. R. Goodnough, San Rafael, Cal., has sold out his business to H. P. Proctor.

L. J. Lyons, Suisun City, Cal., has removed his home to Fairfield, a short distance away.

Henry Bohm, of the Bohm-Bristol Co., who had been at the Denver, Colo., store for two months, left for New York a few days ago.

George E. Bangle, Vallejo, Cal., has taken possession of his new store, formerly occupied by Crowley & Conlon, in the Bernard block. The store has been entirely remodeled and new furniture added.

The girl working in the telephone office next to the Burkham jewelry store, Bodie, Cal., heard a burglar breaking into the store one night last week, and telephoned to the proprietor of the store. The thief, who was loaded down with watches and other jewelry, was caught.

The store of H. S. Harris, Bath, Me., was damaged by fire and smoke recently. The loss was covered by insurance.

J. M. Johnson, Sanford, Me., recently fell through a trap door in his store and sustained injuries which have confined him to his home for the past fortnight.



W. F. Bost has opened a jewelry store Sterling, Colo.

L. Burke has opened a store in Nor Branch, Mich.

Ray C. Bassett has opened a store Woonsocket, S. Dak.

Mr. Halleck, Ord, Nebr., has opened store at Scotia, Nebr.

J. E. Ziegler has started a large manufacturing plant at Stockton, Cal.

Peters Bros., Davidson, Mich., will add a line of jewelry to their general store.

R. J. Baldwin, Cresco, Ia., has opened a repairing establishment in Dubuque, Ia.

A new store was recently opened in Denver, Colo., under the name of Klinger & Co.

H. H. Walker has started in business the Montewshi building, at Minto, N. D.

L. W. Pennington and S. K. Hanley have opened a store at 27 N. 9th St., Worcester, Mass.

A. W. Holmes, formerly a jeweler South Dakota, has opened a store in Nor Lawrence, Kans.

H. A. Potts, formerly of Omaha, Neb., is a new jeweler in Denver, Colo., and has opened a store on Stout St.

The Rhodes Co. has just been incorporated in Seattle, Wash., with a capital of \$100,000, and will handle jewelry, etc.

L. O. Hughes, formerly with Paul McCoy & Co., Minot, N. Dak., has opened a store on his own account in the same place.

Muus Bros. are about to open a jewelry and dry goods store in Grand Forks, Dak. They already have stores in Mir and Velva.

The Wallingford Art Novelty Co., which was organized a short time ago, will begin manufacturing next month in Wallingford, Conn. The plant is on Quinnipiac St., that place, Edward Carter is president.

L. G. Delamothe, formerly of Par France, has opened a factory at 1307 Shannon Ave., Spokane, Wash., for the metallization of flowers, etc., as practised by the Egyptians. The plant will cost \$25,000 and will need about 50 employees.

The Kleine Optical Co. has filed papers incorporation under Missouri laws. The capital stock is \$3,000, fully paid, and the incorporators are Wm. C. Tieman, 28 shares, Wedliel Thomas and Nelson Thomas, one share each. The company will manufacture and deal in optical goods.

C. H. Hinges, Salem, Ore., has completed arrangements to erect an attractive sign in front of his store. The sign will consist of a hollow glass watch in which three incandescent lights will be placed. Outside and entirely surrounding the case will be a circle of electric globes. The inner watch will be suspended from ornamental iron work above the entrance.

Boston.

M. Myers is on a three months' trip to the Pacific coast.

Grover Rasch has entered the employ of Charles W. Jhonnot as watchmaker.

The M. Mordell Co. has removed to room 910 Jewelers' building from Room 63. Leon E. Granstein is to cover New England territory for S. M. Shore, having started on a trip last Monday.

Herbert N. Libby, formerly with Henry Swan, now has charge of the material department of Charles May & Son.

The Baird-North Co., which is closing its business at Salem, Mass., is having final clean-up of goods at auction.

C. S. Blake, who recently moved to Room 1, Jewelers' building, will hereafter carry line of jewelry in addition to maintaining watch sales and repair department.

Fred J. Smiley, a Newton watchmaker, reported financially embarrassed, with liabilities of \$5,294 and assets of \$3,500. He filed a voluntary bankruptcy petition Wednesday.

I. Warshauer, jobber, Jewelers' building, was removed from Room 47 to larger and more convenient quarters, taking Rooms 44 and 45, recently vacated by C. S. Blake and M. J. Graham.

C. G. Aldrich Co. has taken the New England agency for the Cohannet Silver Co., Taunton, and the Aldrich Co.'s sales-room in the Jewelers' building will be the Boston headquarters of the company.

Abraham Figelstone, Worcester, 22 years of age, was convicted, last Wednesday, in the Waltham court of playing a confidence game on the streets in that city by offering "phony" wedding rings to passers-by at nominal sums. He was fined \$25.

By a fire last Thursday night in the studio building on Tremont St., the premises of B. V. How, optician, and the Studio Jewelry Co. were damaged by fire and smoke. They will reopen shortly. The How optical concern is temporarily located in Room 18 in the building.

Word was received from Mackay, Idaho, last week, of the death there, on Feb. 21, of Henry D. Morse, formerly well known in Boston as a watchmaker. A little over a year ago he gave up active employment on account of ill-health, and last September he went west hoping to regain his health. He worked for many years for Parazina and later for F. F. Place Co.

Next Monday a slight increase in the working hours of the Waltham Watch Co.'s employes is scheduled to take place. The new arrangement will provide for nine and one-half hours' work for five days of the week, and the plant will be closed on Saturdays. This is an increase of seven hours per week over the present arrangement, and will benefit 3,500 workers.

Dying almost instantly from heart disease, Henry M. Eaton, 75 years old, a skilful gold and silver engraver, was discovered by his friends, Feb. 20, in the retiring room of the Crawford House. Hoping that some spark of life was left, the body was hurriedly sent to the Relief Hospital, where the physicians pronounced the death as instantaneous and due to heart disease.

The New England Watchmakers' Club is meeting with success in its class instruction

project. There are three of these classes which meet at the club room on Bromfield St. and are instructed by experts from the Waltham Watch Co.'s factory, who volunteered their services on behalf of the organization. The subjects taken up have been the trueing and poising of balances and the trueing of hairsprings.

North Attleboro.**TRADE CONDITIONS.**

Business, which has been very quiet the past few weeks, shows some signs of picking up. Better and larger orders were received by manufacturers during the past week than for some time past. The restoration of confidence is all that is needed before business will begin to be good in the opinion of the larger manufacturers, who declare that jobbers are low in stocks and must give big orders when business begins to move.

George L. Paine is on a western trip.

Oscar H. Hornig left Monday on a three weeks' trip for the Codding & Heilborn Co.

Louis D. Barrows was in New York last week on business connected with his concern.

H. A. Scofield and C. A. Scofield returned last week from business trips for Scofield, Melcher & Scofield.

Charles Hopkins, for many years a plater with E. I. Franklin & Co., died at the Massachusetts General Hospital last week.

R. G. Avins, Chicago; F. H. Strong, New York, and A. Frederickton, New York, were in North Attleboro on business the past week.

The residence of William H. Riley was visited by burglars on the evening of Feb. 25 for a second time within a few months. An entrance was gained through a dining-room window. The marauders evidently were hunting only for cash, as silverware was passed by unmolested. On the previous visit \$225 in money and considerable silverware was taken.

Speaking before the Men's Club of the Baptist Church, Robert J. Fuller, superintendent of the North Attleboro public schools, gave an interesting talk upon "Industrial Education in Germany: Its Rise, Its Significance." He gave a very comprehensive talk upon the work being done in Germany and urged the support of a similar method in Massachusetts.

Announcement was made by Charles G. Bancroft, receiver of the insolvent Jewelers' National Bank, that the first dividend would come in March, and that he would recommend not less than 60 per cent. The assessments have come in freely and arrangements have been made whereby all but three blocks will be cared for. President A. H. Wiggin sent in his check for \$21,200. He owned 212 shares. Suits will be brought against those who have failed to meet the demands.

At a meeting held Saturday evening a petition making application for a new Jewelers' National Bank was filed with Comptroller of the Currency Ridgely. The petition was signed by Joseph L. Sweet, of the R. F. Simmons Co.; George K. Webster; Albert Totten, formerly of Totten Bros.; Walter B. Ballou, of R. Blackinton & Co.; Fred E. Sturdy, of J. F. Sturdy & Sons; Charles O. Mason, of the Mason Box Co., and Fred A. Howard, of Frank M. Whiting & Co. A meeting of the stockholders

will be held as soon as the subscriptions are collected, and an organization will be then perfected. It is expected that the bank will be prepared to do business in April.

Attleboro

George L. Shepardson, of C. A. Marsh & Co., left last week for New York for a trip with his sample case.

Arthur A. McRae, of McRae & Keeler, and William Saart, of W. H. Saart & Co., have returned from several days' fishing trip down Cape Cod.

Col. Sidney O. Bigney, of S. O. Bigney & Co., who now seems certain to be a delegate-at-large to the Republican national convention, issued a statement last week that he should be unpledged.

Work was suspended for part of last week at the R. F. Simmons Co. factory, owing to an explosion which wrecked the blowpipe running around the main room of the plant. The noise was loud, but the damage was not great.

Emil Holmberg, employed by Sturdy Bros., and Alrick Sturk, employed by the C. H. Eden Co., left last week for a walk to Mexico City. They are skilled workers and expect to engage in some form of jewelry work in the southern republic. A few years ago they made a similar walking trip over Europe.

Charles E. Bliss, formerly of Bliss Bros.; Mark E. Rowe; Everett S. Horton, of the Horton-Angell Co.; Harry P. Kent, of F. W. Weaver & Co.; Edgar A. Remington, of Carter, Qvarnstrom & Remington, and Ernest M. Bliss, of the Bliss Bros. Co., were last week made trustees of the Richardson school fund.

Edward N. Bliss, son of the late Everett B. Bliss, of Bliss Bros., who was himself formerly interested in the jewelry business, was married last week to Miss Lena Hutchinson, daughter of the late Joseph G. Hutchinson, salesman for Smith & Crosby. Chester Howard, with W. E. Richards & Co., acted as best man.

So serious has become the industrial situation in this town that a mass meeting of unemployed was held in a local hall Saturday night. Business in the jewelry factories is not brisk enough to provide work for all the jewelers, and real distress is beginning to be felt in many homes. The meeting was called to discuss the proposition of special municipal work to furnish occupation and an income to those in need. Emmons D. Guild, of W. H. Wilmarth & Co., and Charles O. Sweet, of C. O. Sweet, Son & Co., were present and spoke, as did men representing other industries. A committee was appointed with C. O. Sweet as one of its members to devise ways to relieve the situation.

Creditors of Jones & Frasier, Durham, N. C., for whose business a receiver was recently named in the State courts, have filed an involuntary petition, asking that the concern be declared bankrupt, setting up the receivership as an act of bankruptcy to sustain their claim. The defendants deny that there is any cause for the bankruptcy court to intervene, and have demanded a jury trial, and a hearing on the petition has been set for March 18.

Pittsburg.

An auction has been started at 932 Liberty Ave.

Page Dieffenbach, a watchmaker, has accepted a position with W. W. Warwick.

George West, of West, White & Christy, who was on the sick list for a few days, is all right again.

B. E. Brown, of Monessen, and P. J. Manson, of Jeanette, were in Pittsburg last week, buying goods.

Charles O'Brien, it is said, will enter the employ of L. W. Vilsack & Co. when that firm opens up in Mr. O'Brien's former location in Wood St.

W. G. Spies has sent out cards announcing the marriage of his daughter Louise Johanne to Charles Frederick Becker, Feb. 28, at Steubenville, O.

The Hardy & Hayes Co. sold the cups offered by the Press Tournament League, the cups being especially handsome. The medals being offered were also designed by this house.

P. C. Gillespie spent a few days of last week in New York. He was accompanied by Mrs. Gillespie and the couple will spend a few days at Cambridge Springs before returning to Pittsburg.

Arthur Bradshaw, a well-known traveling salesman, who was in Pittsburg last week, was given a royal reception. He had been seriously ill with typhoid fever, and it was his first visit here since his recovery.

The Jewelers' Duckpin League rolled another game last Thursday night, the Wattles team again coming out victorious with a score of 260. Messrs. Letzkus, Daub and Wagorian, of the L. J. Vilsack team, and Messrs. Bender, Flath and Rosen, with the A. E. Siedle & Co. team, have joined forces with the league. Games will be rolled every Thursday night on the Dispatch alleys. Six firms are now represented in the league.

The report mentioned last week that J. T. Montgomery, local manager of M. A. Mead & Co., would return to the Chicago office, and the salesmen operating out of the Pittsburg office had been withdrawn from the road, is denounced as absolutely incorrect by Mr. Montgomery. He says that the company is in no way curtailing its territory, but on the contrary has put out four men since the first of the year as against two in 1907. As to himself Mr. Montgomery says, though he has been elected vice-president of the company, which will require trips to the home office in Chicago from time to time, he has no intention of returning to Chicago, but will remain as before the active manager of the Pittsburg office. How the report in question could have originated, he says, he is at a loss to understand.

The stockholders of the Geo. B. Barrett Co. met last week and reorganized by electing the following officers: Henry A. Barrett, president; C. P. Byrnes and W. G. Stewart, vice-presidents; F. F. Aul, secretary and treasurer. The officers, with W. G. Ingham and George S. Dunbar, comprise the board of directors. Mr. Barrett, who succeeds his father as president of the company, has been an invalid for about two years. Messrs. Byrnes and Stewart are sons-in-law of the late George B. Barrett, Mr. Stewart being an attorney. The business

management of the house will, however, be under the direction of Mr. Ingham and Mr. Dunbar, Mr. Ingham being the buyer. He has been the active head of the house for a number of months past, and the business will be continued as heretofore, the Barrett estate maintaining its interest in the business.

It is proposed to build a city hall on the site bounded by Fifth Ave., Masters Way, Union and S. Diamond Sts., and if the city carries out its plans for or five jewelry houses must find new locations. J. C. Grogan & Co., J. R. Reed & Co., the John M. Roberts & Sons Co. and others would be affected by the improvement. The last-named house has a 10-year lease on its present location, so that if the property talked of is acquired this firm would have to be reckoned with by the city. Much money was spent by the firm in remodeling its new building. It is proposed to build a plaza in front of the new hall, and this would be of incalculable value to the Hardy & Hayes Co., which would be directly opposite in Fifth Ave., and to the E. P. Roberts & Sons Co., a little further up the street. The city proposes to sell its present city hall building and spend \$3,500,000 in the erection of a building and market house large enough for the use of the combined cities. The matter has caused a lively interest among the jewelers in the jewelry section of the city. Mr. Grogan's lease, it is said, expires this year, while the Reed firm re-leased last year for a period of three years.

Mrs. M. L. Patterson, who was arrested Feb. 26 in the store of Henry Wilkins & Co., 440 Wood St., on suspicion, was discharged the following day because of the insufficiency of the evidence against her. The police were notified about six weeks ago that a diamond brooch valued at \$300 had been taken from the store. Mrs. Patterson had visited the store, according to the story told the police, and had stated that she wished to have a diamond brooch. She telephoned the store to send a clerk out to her house in order that she might select one. She, however, visited the store in person and inspected some pieces. One brooch is said to have been missed from the store at the time. Wednesday morning Mrs. Patterson called at the store and asked to see some diamond earrings, and later a pair was found to be missing, and Policeman Daniel Welsh was summoned to the store. Mrs. Patterson was placed under arrest and taken to the Central Police Station, and detectives visited the woman's home. An investigation did not reveal sufficient evidence to hold the woman and the police discharged her from custody.

The case against Frank Gardner, of Gardner Bros., Charlotte, N. C., charging him with having received stolen goods, was dismissed about a week ago.

Miss Hazel Eugenia Meyer, daughter of F. G. Meyer, Dayton, O., and F. Edward Sweetman were married Feb. 25 at the Sacred Heart Church, Dayton. Miss Meyer is well known in the jewelry trade, having been associated with her father in his store for several years past and has been the recipient of many messages of felicitation upon her marriage.

Lancaster, Pa.

Francis Pickering, Milwaukee, Pa., is visiting relatives in Lancaster, where he spent part of his boyhood days.

Frederick G. Kirchner, with the Hamilton Watch Co., was married, Feb. 27, to Miss Anna Freiler, of Lancaster.

Ellis Murdock, Pittsburg, head clerk for a jewelry firm, while en route to New York with his bride, last week, stopped over in Lancaster a few days to visit friends in the trade.

Percy W. Appel, with Wm. W. Appel, a favorite Lancaster baritone, last week took a leading role in the production at York, Pa., of the musical extravaganza, "The Talk of the Town."

The directors of the Hamilton Watch Co. last week re-elected their old officers for the ensuing year: President, Charles D. Rood; treasurer, Charles F. Miller; secretary, J. W. B. Bausman.

W. F. Meiskey, of the H. S. Meiskey Co., and Fred A. Wheeler, of the Non-Retailing Co., were among the guests at the annual banquet of Lancaster Lodge of Elks, Thursday evening last.

At the banquet held on the evening of Feb. 27, by the Lancaster Lodge of Elks, John K. Tener, Charleroi, Pa., Grand Exalted Ruler of the United States, was presented with a beautiful silver loving cup, furnished by Augustus Rhoads, of this city. It was suitably engraved and stood on a solid ebony pedestal.

Edward Rosenstein, of the Lancaster Silver Plate Co., on the night of Feb. 27, distinguished himself by being one of the several persons who pursued three thieves who had just raided a residence. C. Hallendate a representative of this company, left last Wednesday to visit the western trade and will be absent six months. He will show in Chicago a full line of novelties during the month of April.

At a sale of the effects of the late Christian Musselman, of this city, last week, a grandfather's clock was sold to Omer Musser, Manheim, Pa., for \$75. It was made by Joseph Bowman, Strasburg, No. 50, and had brass works in a cherry case paneled in mahogany. A Seth Thomas clock, made on special order, which strikes the quarter, half and three-quarter hours, was sold to W. Grant Barr for \$20.

B. D. Bemis, of Avery & Bemis, jewelers, Amherst, O., who was a student in engraving at the Ezra F. Bowman Technical School, was called home last evening by his partner's illness. Jacob Ziegler, Schock Mills, Pa., has returned to the school after a trip to his home. Charles A. Bawder, Cambridge, O., a former jeweler of East Liverpool, O., has entered the school as student in the engraving and watchmaking departments.

Walter A. Whitney, Brushton, N. Y., is sending out neat calendars, showing a half-tone reproduction of the exterior of his jewelry establishment.

Frank A. Elmer, jeweler and optician, Hudson, N. Y., has decided to retire from the jewelry business and devote his entire attention to his optical trade. He started in the jewelry business in 1894. His stock will be sold at auction.

New Orleans, La.

TRADE CONDITIONS.

Business conditions in this city have improved somewhat in the last few days, caused by the event of our coming Mardi Gras which always stimulates business. During Mardi Gras a great many balls are given by the different carnival organizations, at which a number of presentations are made and consequently ladies' jewelry is in great demand. Souvenirs consist mainly of brooches, bracelets, barrettes, etc., which are always very beautiful. The organizations generally have their own designs which are made up by the local jewelers. In the order as many as 200 or 300 of a kind with the monogram of their organization.

Mr. Zurbrugg and C. M. Fogg, of the Key-Note Watch Case Co., were visitors to this city recently.

The auction of M. Scooler turned out far more successful than was anticipated. The sale was well attended.

A. G. Balfry, vice-president of A. B. Griswold & Co., was married Feb. 22, and is taking a wedding trip through Mexico. E. Barbier, a well known jeweler of the French quarter of this city, has recovered from a serious illness and will soon be at his post.

The firm of Leonard Krower has received a number of requests for accommodation from the jewelers who intend to be here during Mardi Gras.

The Lucios Diamond Co. has opened a beautiful store on St. Charles St., near Canal St., and its window is one of the handsomest in the city, being illuminated by innumerable electric lights during the day as well as night.

A presentation was lately made to Bernard McCloskey, president of the new court building commission of a genuine silver bowl, with genuine ivory handle. The building was represented on one side of the bowl, and on the other side was the inscription. This trowel was made by Coleman E. Adler.

With the event of our coming Mardi Gras a great many visitors are expected here, especially in the jewelry line. As Leonard Krower always makes it a point to invite the firm's customers to the city special advertisements, the entire traveling force, consisting of M. Dorenfield, M. Jacobs, M. Goodman, V. Wolsch, H. Watson and E. Magnus, will be in the city to entertain their customers.

A desperate negro recently made a bold attempt to rob the show window of S. Bertel, a pawnbroker, at Tulane Ave. and Campart Sts., by throwing a cobble stone through the glass. The negro snatched two wolvers valued at \$20 and fled up Common St. He was chased into Royal and Canal Sts., where he was captured. The negro gave his name as Samuel Jefferson and admitted that he is wanted in Monroe on a charge of shooting and dangerously wounding a negro there.

With the approach of Mardi Gras the jewels of the different kings and queens are exhibited. In A. B. Griswold's window may be seen the jewels of the King and Queen of Comus, which consists of necklace, girdle, bracelets, shoulder pins, scepter and crown. The workmanship is most exquisite. In the window of Coleman E. Adler the jewels of the King and Queen of Comus are displayed. The window is very appropriately decorated in Rex colors,

which are purple, yellow and green, and likewise appending is a list of all the kings and queens who have reigned at the different balls of this organization since the year 1872. In the window of D. H. Holmes are displayed the jewels of the King and Queen of Proteus. These are also very handsome, set with rubies, emeralds and white stones.

This city has suffered quite severely from quite a number of robberies, the following jewelry establishments having been broken into: The Progressive Novelty Store (A. I. Hirsch), L. Frigerio's Sons, William Frantz & Co. and the Lowengardt, Armstrong Co. It is reported that the men who robbed William Frantz & Co. have been discovered and are now in prison. It is more than likely that this will lead to further discovery as to the parties who robbed the other jewelers.

Baltimore.

The silver fruit bowl, fork and spoon presented to Dr. Jacob H. Hollander, last week, by his associates on the Committee on Taxation were made by Jenkins & Jenkins.

The estate of the late Thomas F. Wealc was appraised last week by the court appraiser at \$214,985. The inventories were filed in the Orphans' Court by the Safe Deposit & Trust Co. as executor. Mr. Wealc having never married, the bulk of the estate was left to relatives.

The Co-operative Specialty Co. was incorporated on Friday for the acquiring and developing of patented novelties. The incorporators are Myer Levy, Louis Maseritz, Benjamin Bratman, Joseph Gostomalsky and Herman Becker, the authorized capital stock being \$1,000, divided into 100 shares of \$10 each.

Harris Cohen was recently convicted in the Criminal Court of the charge of receiving stolen goods, and was sentenced Thursday to 18 months in the Maryland Penitentiary. The stolen goods in the case consisted of a diamond ring valued at \$200 which he bought from Julius Lieberman. Cohen said he gave the man \$73 for the ring, but Lieberman said he only received \$33. Cohen's store is on S. High St. When sentenced he wept bitterly.

At the Designers and Artisans' Club exhibit last week at 525 N. Charles St. there was an interesting exhibit of English and American hand-wrought jewelry, enamels etc., which afforded an opportunity for a comprehensive study of the two methods. The English collection was brought to this country by the Detroit Society of Arts and Crafts. It is large and valuable and includes a number of pieces of work by Alexander Fisher, who is one of the greatest living metal workers. A silver box, set with stones, and a jewel casket show remarkable skill. One of the distinctive features of the English collection is the great number of settings in jewelry and the quantity of enamel used. The work of the Americans is simple and dignified. In technique and methods of treatment the two schools are similar.

E. L. March, Fort Dodge, Ia., will build a residence on First Ave., N., shortly. Plans are being arranged.

Paris Notes.

PARIS, France, Feb. 20.—A note in the Anniversary Number of THE JEWELERS' CIRCULAR—WEEKLY, which, by the way, has been most favorably commented upon by the trade of this city, spoke of the bankruptcy of D. Cohen, of 27 rue Laffitte. On the chance that he might be confounded with Jules E. Cohen, 58 rue Laffitte, who visited the American trade last Fall, it should be stated that there is no connection whatsoever between the two houses.

L. Gauthier, president of the Chambre Syndicale des Négociants en Diamants, addressed a letter to the president of the Diamond Syndicate of London, the De Beers Consolidated Mines, Ltd., and the Premier Diamond Mining Co., calling their attention to the telegram sent by the Syndicate to Leopold Stern, of Stern Bros. & Co., New York, in which the Syndicate told of its intention to maintain diamond prices, and asking for an official confirmation of this statement. In response to the letter President Gauthier received direct communications from L. & A. Abrahams, of the London Syndicate; E. R. Tymm, secretary of the De Beers Consolidated Mines, Ltd., and W. Busch, representative of the Premier Diamond Mining Co., each reiterating the statement sent in the cable to New York to the effect that "the Syndicate will continue their policy of maintaining prices; this in agreement with the De Beers and Premier mines." Messrs. Tymm and Busch adding that their companies concurred in the above statement. The letters have been published by the Chamber in circular form, with a fac-simile of the letter-heads and a translation of the English into French in parallel columns. This circular has been sent to the entire diamond trade with excellent results, and it has practically settled all rumors as to the future of the diamond market.

Columbus, O.

E. G. Knoop, of this city, has received a patent on a scarf pin.

The Harrington Co., of this city, was incorporated recently with \$20,000 capital stock by William G. Harrington, Mary L. Harrington, G. Dana Harrington, Gordon M. Harrington and George C. Ruth.

The Denman bill, providing for a committee of optometry to be connected with the State Board of Medical Registration and Examination, still rests in the committee to which it was referred by the Senate. The bill is one drawn up by and introduced at request of the Ohio State Optical Association. The Senate committee and the members of the association and their attorney, Judge Okey, have been unable to agree on a date for a hearing, but have finally decided on to-morrow (March 5). There have been some objections to certain sections of the bill by a few opticians, but only as to minor details. These will be changed to meet the objections. As the bill stands, it does not recognize optical schools unless connected with a medical college. It is not thought the bill will meet with a great deal of opposition in either the Senate or House.

Oscar H. Iltis, Chaska, Minn., is an agent for the Edison phonographs.

Philadelphia

I. B. Braverman, Reading, Pa., is conducting an auction sale to reduce his stock.

F. L. Shaw, Federal St., Camden, has completed extensive alterations to his store.

F. D. Grover, 2006 Germantown Ave., was confined to his home recently with the grippe.

J. B. Bechtel, of Joseph B. Bechtel & Co., has returned from a tour of the Lehigh Valley.

J. Lcskin, 1711 South St., was robbed last week of diamond jewelry valued at \$70. The thief escaped.

Samuel Kind, of S. Kind & Sons, 1110 Chestnut St., contemplates a pleasure trip of three weeks to Cuba and the West Indies.

A. Smith, with John A. Kinsler, manufacturing jeweler, 1020 Chestnut St., is convalescent from a severe attack of the grippe.

J. E. Caldwell & Co. made the handsome silver service which was last week presented to Monte Cross, a famous baseball player.

Isaac Press & Son, 8th and Chestnut Sts., were victims last week of a smooth swindler who substituted an imitation stone for a genuine diamond.

Ernest Miller White, a prominent mining expert, of Black Warrior, Va., visited the trade in this city recently to purchase lathes for drilling.

The Superior Comb Co. instituted suit in the local courts last week to recover on a contract alleged to have been entered into with I. Press & Son.

George Hunt, formerly with M. Sickles & Sons, but now with I. Eiseman, Pittsburg, is traveling for pleasure and recreation, but contemplates returning to this city.

F. B. Wallen, Broadway, Camden, was chosen last week as one of the committee of business men to urge the Pennsylvania Railroad not to abandon Hatton Ave. station in Camden.

The first meeting of the creditors of Sperling & Goodman, bankrupt jewelers, 8th St., near Vine St., was held Thursday at the offices of the referee, D. W. Amram, 710 Penn Sq. building.

Retailers visiting here last week included: D. H. Krause, North Wales; W. L. Roberts, Wilmington; H. B. MacFarland, Mauch Chunk; E. L. Thomas, Phoenixville, Pa., and E. Allez, Millville, N. J.

Wm. Purnell, who has represented the Wm. C. Penfold Co. in this city and vicinity, will not change his territory by the concern's removal to New York, but will visit the Philadelphia trade as in the past.

Frederick Schober, a retired naval engineer, died in St. Agnes Hospital last week. After his retirement from the Navy he became engaged in various enterprises, helping to organize the National Watch Case Co.

Thomas Madden, with M. Sickles & Sons, was recently elected an assessor in the 34th Ward, and is receiving the congratulations of his friends in the trade, who assure him that he must continue to achieve political distinction.

Charles Rees, 142 W. Dauphin St., who has just recovered from a tedious illness, and who is one of the most prominent retailers in his section of the city, has decided to retire and has sold his store to E.

Jaschik, a jeweler who recently came here from South Africa.

Abe and Ed. Sickles, of M. Sickles & Sons, departed last week for a pleasure trip to Bermuda, accompanied by their families, and will be gone about a fortnight. Abe Sickles proposes later to go abroad to purchase diamonds for his firm.

Frederick Barry, a well-known traveler, who has been resting at his home in Germantown since his return from an extended trip through the west, left again last week to be gone about six weeks. Mr. Barry says that business in the west, especially St. Louis and Minneapolis, is brisk.

The assigned estate of James M. McCulloch, for years a well-known retailer at 33 S. 8th St., is to be removed to the auction rooms at 12th and Walnut Sts. and disposed of, Wednesday next, at 10 A. M. The order for the sale was made last week by Fred B. Hurlburt, of H. O. Hurlburt & Sons.

Andrew Little, with J. B. Bechtel & Co., has returned from a honeymoon trip with his bride, *nee* Miss Bertha Bierlin. Mr. Little is receiving the congratulations of his friends in the trade. J. B. Bechtel, head of the firm, returned last week from a thorough canvass of the Schuylkill and Lehigh valleys, and reports business as entirely satisfactory.

Creditors have filed a petition in the United States District Court to have David Baylinson, manufacturing jeweler, 731 Sansom St., adjudged an involuntary bankrupt. The creditors so far known are Albert Lorsch & Co., \$623.18; Wm. I. Rosenfeld, \$496.42; Malliet & Maxwell, \$1,862.71. Arthur L. Cohn, in addition, obtained judgment against Baylinson for \$763.64.

Roy Herbert, 1022 Arch St., caused the arrest last week of Edward Sommers, 1813 N. 13th St., in a suit for \$1,000 damages for false arrest. Herbert charges that Sommers caused his arrest for the larceny by bailee of a diamond ring and two gold watches, whereas he maintains he bought the jewelry on instalments from Sommers, but had a disagreement over payments.

L. P. White, 9th and Chestnut Sts., departed Wednesday for an extended trip through the south. Mr. White accompanies, with several other prominent Philadelphians, the Athletic baseball nine, which is going south to "limber up" before the baseball season is under way, and will attend the Mardi Gras after a short sojourn in Cuba and the fashionable Florida resorts.

In the arrest Saturday of Ashton Andrews, alias "G. W. Andrews, M.D., Nero Cruz, Mexico," for the alleged act of attempting to substitute a paste ring for a genuine diamond in the store of S. Rosenblatt, 2605 Germantown Ave., Captain of Detectives Donaghy believes he has made an important capture. Mr. Rosenblatt, believing he had detected the man, quickly called in a policeman. Andrews is suspected of being a man who made several recent attempts to rob jewelers in various sections of the city by the old reliable pennyweight game. Newspaper clippings and other data found in the prisoner's possession indicate him to be a discharged Honduran filibuster recently released from three years' imprisonment. Andrews also had letters from financial institutions in Vera Cruz.

Canada Notes.

George E. Trorey, Vancouver, B. C., was in Toronto, this week, on his way to New York and the eastern markets.

W. W. Tyrill, St. Catharines, Ont., who is in financial difficulties, is endeavoring to obtain an extension of time from his creditors.

M. C. Ellis, of P. W. Ellis & Co., Toronto, left, last week, for a European tour of several months. He is accompanied by Mrs. Ellis.

Out-of-town buyers calling on the Toronto trade this week included J. B. Kambro; J. Park, Bradford; E. D. Wilcox, Uxbridge; Edward F. Davis, Tillsonburg; William Delaney, Jr., Cobourg, and J. Johnson, Attwood.

Samuel Finkle, the manufacturing jeweler charged with conspiracy with H. Green to defraud the London Fire Insurance Corporation, was discharged, Feb. 27, there being no evidence of conspiracy, but was committed for trial on a new charge of attempting to defraud.

Sadie King, a young woman who was formerly in charge of the stock room of Roden Bros., silversmiths, Toronto, but has latterly been out of employment, was arrested, Feb. 21, on the charge of stealing silver forks from Roden Bros. The theft was detected by the attempt of two boys to dispose of six silver forks at a pawnshop. They could not account for the forks being in their possession and fled when questioned. The forks were handed over to the police and claimed by Miss King of Roden Bros. were communicated with and found their stock short. Miss King admitted the theft, it is said.

Buffalo, N. Y.

Samuel Derefsky, Niagara Falls, N. Y., recently confessed to a judgment of \$642.50 to Morris Rosenbloom, and his jewelry store on Main St. was closed by a marshal to satisfy the judgment.

Some jewelry was recently stolen from the show window of the Triangle Jewelry Store at Triangle St. and Abbott Road. The thieves broke a pane of glass in the window and reached through the hole for the jewelry.

The Buffalo police are on the lookout for the burglars who recently stole \$1,000 worth of jewelry from the store of W. Geneth Bros. at Sheran, Pa. It is thought that the robbers may have come to Buffalo to dispose of the stolen goods.

Comerford & Bush, at 1627 Broadway, recently entered a complaint against a railroad fireman of this city and had the man arrested. It is said that he bought a watch on the instalment plan and sold the timepiece before he had completed the payment.

Jireh Kinney, 92 Seneca St., a veteran jeweler, has the sympathy of the trade for his recent bereavement due to the death of his son, Paul L. Kinney, which occurred at East Aurora, Feb. 16. Young Mr. Kinney was hurt in an automobile accident over a year ago, and after his recovery complained of severe pains in his head. He died suddenly without warning, and it is believed that his death was due to heart failure which was superinduced by his accident.

INDEX TO ADVERTISEMENTS.

Al Bros. & Co.	25	Harris & Harrington	98	Prior, Charles M.	32
Aspöpp Bros.	31	Hedges, A. J., & Co.	27	Racine, Jules, & Co.	100
Aspin Mfg. Co.	Inside front cover	Hedges, Wm. S., & Co.	56	Randall, C. Ray	15
American Gem & Pearl Co.	58	Heintz Bros.	8	Ranlett & Lowell Co.	98
American Platinum Works.	106	Heller, L. & Son.	50	Reichhelm, E. P., & Co.	106
American Watch Case Co.	100	Herpers Bros.	166	Reichman, A.	60
Albald-Klement Co.	26	Hight Mfg. Co.	112	Reinziehausen, W. E., & Co.	114
Arizona Turquoise Mines Co.	50	Hill & Schmidt	25	Revell, A. H., & Co.	113
Aronstein Bros. & Co.	44	Himalaya Mining Co.	60	Rice's, Bernard, Sons	78
Aronstein Bros. Co.	71	Hirsch & Hyman.	50	Richards, J. M.	58
Austin, John, & Son.	115	Hodenpyl & Walker	52	Richardson, E. Os., & Co.	24
Austin & Stone	37	Hoffman Novelty Co.	36	Robbins, Chas. M., Co.	34
Avg., Perine & Co.	54	Hooper H. J.	38	Rockford Silver Plate Co.	76
Ayer, Geo. M.	113	Hotel St. James	110	Rockford Watch Co.	101
Ball, Webb C., Watch Co.	99	Hraba, Louis W.	110	Roger Williams Silver Co.	33
Balschopf, Henry C.	33	Hyde & Co.	98	Rohrbeck, John E.	38
Bastian Bros. Co.	14	Illinois Watch Co.	72	Roseman, A.	60
Bassett Jewelry Co.	36	International Gem Co.	54	Roy Watch Case Co.	88
Bates & Bacon.	14	Irons, Joseph	110	Rudolph & Suedeker	98
Baugh, J. & H.	114	Irving Cut Glass Co.	110	Rumpp, C. E., & Sons	112
Bearings, Chester, & Son.	52	Jacot Music Box Co.	110	Saart, W. H., Co.	68
Beckhart, Griscom & Osborn.	26	Jantitsek Co.	106	Saunders, Maurer & Co.	56
Beckshop, R. W.	113	Jeanne, E. A.	48	Schultz & Co., Inc.	29
Beckinton, R., & Co.	13	Jorgeson, F. C., & Co.	112	Sessions Clock Co.	98
Belles, Wm., Co.	113	Jurgensen, Jules	98	Shepard Mfg. Co.	16
Benet, L.	25	Kahn, L. & M., & Co.	44	Shimons, R. F., Co.	22
Bergzinner, S., Co.	70	Keller Jewelry Mfg. Co.	26	Smith, Alfred H., & Co.	48
Berrelli & Vitelli.	58	Kent & Woodland	28	Smith, Frank W., Co.	17
Bowden, J. B., & Co.	31	Ketcham & McDougall	36	Smith, Wm., & Co.	36
Bradley Polytechnic Institute.	38	Keystone Watch Case Co.	94	Snow & Westcott	28
Briggs, D. F., Co.	12	Kinney Co.	35	Sohn & Hyman	60
Briggs Piano Co.	37	Kirby, H. A.	64	Solderine Co.	106
Brarter, Howe & Co.	25	Kohlbasch, Herman, Sr.	113	Solidarity Watch Case Co.	17
Bratham National Bank.	68	Kohn, Alois, & Co.	29	Spencer, E. L., Co.	35
Chicago Art Metal Works.	30	Krenentz & Co.	23	Star Watch Case Co.	6
Chopard Frères	30	Krower, Leonard	35	State Bank	66
Cincinnati Gold & Silver Refining Co.	68	Langendorf Watch Co.	98	Steiner, Louis	110
Clinley & Straight	114	Lapp & Flershem	76	Stern & Corn	32
Cottle, S., Co.	29	Larter & Sons	42	Stern Bros. & Co.	50, inside back cover
Crees & Conrt.	33	Lederer, S. & B., Co.	34	Sternau, S., & Co.	12
Crohn, M.	31	Leiman Bros.	106	Stilwell, L. W.	34
Cross & Beguelin	52, 64	Lelong, L., & Bro.	114	St. Louis Watchmaking School.	38
Crossman Co.	54	Lewy & Cohen	78	Street, Geo. O., & Sons.	31
Crouch & Fitzgerald	112	Libby Glass Co.	108	Sussfeld, Lorsch & Co.	100, 113
Cray, Clark & Co.	27	Lisner, D., & Co.	18	Swartzchild & Co.	78
Crocon, Louis J.	29	Lissauer & Co.	54	Tavannes Watch Co.	60
Croderick's, James H., Sons.	115	Lorsch, Albert, & Co.	44	Theberath & Co.	84
Croxon, Wm., Inc.	114	Lowe, Edwin, & Co., Inc.	30	Title Guarantee & Trust Co.	66
Crovan, Bagnall & Co.	36	Maiden Lane Realty Co.	19, 20	Trout, Charles L., & Co.	28
Croffinger, C., & Sons.	110	Maintien Bros. & Elliot.	31	Untermeyer-Robbins Co.	70
Cropper, O. M., Estate.	33	Market & Finton National Bank.	66	Urich, S.	84
Crozier Watch Case Co.	99	Marson, A.	115	U. S. Smelting & Refining Works.	115
Crozier-Hampden Watch Mfg. Co.	10	Mercantile National Bank.	67	Van Dam, Eduard	46
Crum, T. J., Co.	30	Meyerowitz Bros.	46	Van Dusen & Stokes Co.	31
Crum and Co.	24	Miller, Fuller & Whiting Co.	37	Van Schoor, C.	34
Crichberg & Co.	60	Miller, L. A. (Insurance).	26	Wachter Mfg. Co.	99
Crisenmann Bros.	52	Mount & Woodhull	54	Wadell Show Case & Cabinet Co.	112
Crozier National Watch Co.	92	Myers, S. F., Co.	30	Wadsworth Watch Case Co.	9
C. P. H. Chain Catch.	60	Nassau Bank	66	Waite-Thresher Co.	38
Cahys, Joseph, & Co.	3	New England Watch Co.	97	Waltham Clock Co.	100
Caldenheimer, Louis	70	New York Jewelry Purchasing Co.	28	Waltham Watch Co.	90
Caldwell, Theodore W., & Bro. Co.	40	New York Standard Watch Co.	96	Washburn, C. Irving	113
Caldwell, Henry, & Bro.	18	Nissen, Ludwig, & Co.	27	Wells, Chester H.	33
Caldwell, R. L., & M.	46	Noel, Rudolph, & Co.	48	Wendell & Co.	7
Calaway, J. H., & F. H.	30	Oneida Community, Ltd.	Outside back cover	Wheeler, Hayden W., & Co.	48
Calveray & Griser	29	Oppenheimer Bros. & Veith.	46	Whiting & Davis	15
Callette Sales Co.	39	Oskamp-Nolting & Co.	28	Whiting Mfg. Co.	11
Goodfriend Bros.	56	Osmers Dougherty Co.	29	Wightman & Hough Co.	32
Gorham Co.	62	Osmun Parker Mfg. Co.	24	Wodiska, Julius	28
Grand Rapids Show Case Co.	113	Ostby & Barton Co.	16	Wolcott Mfg. Co.	21
Griffoul, August	115	Owanda Cut Glass Co.	110	Wolfsheim & Sachs	34
Gugenheim, M.	33	Page-Davis School	84	Wollstein, L. & M.	115
Gagerstrom Co.	28	Papazien, A. D.	34	Wood, Chas. F., & Co.	52
Hagstoz, T. B., Ltd.	114	Penfold, Wm. C., Co.	101	Wood, J. R., & Sons	4, 5
Hahn, E., & Co.	50	Pitcairn, W. S.	112	Zarembowitz, A.	106
Hammel, Riglander & Co.	116	Pitzele, S.	30	Zimmern, Henry, & Co.	115
		Potter & Buffinton Co.	32		

Special Notices.

Payable invariably in advance.

Rates 75c. per insertion for notices not exceeding 25 words; additional words, 2c. each.

SITUATIONS WANTED, 1c. a word each insertion; minimum charge, 25c.

Heavy type, 5c. a word; minimum charge, \$1.25. Display cards, \$2.00 per inch.

In all cases, if answers are to be forwarded, 10c. extra to cover postage must be enclosed.

All answers to advertisements addressed care *The Jewelers' Circular-Weekly*, should be sent to the New York Office, unless the Chicago Office is specifically mentioned.

Situations Wanted.

DO YOU NEED HELP? Write your wants to "Experience, 3567," care Jewelers' Circular-Weekly.

ENGRAVER and saleslady, experienced; best of references. Address "P. C. L., 3514," care Jewelers' Circular-Weekly.

YOUNG MAN wishes position as engraver and watchmaker; has tools. Address "B., 3502," care Jewelers' Circular-Weekly.

FIRST CLASS watchmaker and salesman, able to manage, no butcher; own tools; good reference. J. B. Lollis, Litchfield, Ill.

FIRST CLASS diamond setter, special milgrán setting, wants position. Address "M. J., 3563," care Jewelers' Circular-Weekly.

THOROUGH, practical, rapid and experienced watch repairer, disengaged April 1. J. A. Coon, 548 Warren St., Hudson, N. Y.

POSITION WANTED by engraver; all kinds of lettering and monograms; references given. Urban Dean, Cameron Mills, N. Y.

BOOKKEEPER, experienced double entry; can take charge of office; best reference. Address "N., 3533," care Jewelers' Circular-Weekly.

BY MARCH 15, second watchmaker, good engraver and optician; single; age 23; best reference. "H. B.," 1013 S. 3d St., Elkhart, Ind.

YOUNG MAN, 20, desires position as clerk or salesman in wholesale or retail jewelry house. Address S. Herzberg, 235 E. 11th St., New York.

FIRST CLASS watchmaker desires to make a change; young man, good habits; A1 references. "Watchmaker, 3530," care Jewelers' Circular-Weekly.

PAWNBROKER; setter would like to learn the pawnbroking business; honest, with best reference. "J. L., 3505," care Jewelers' Circular-Weekly.

POSITION by first class watchmaker and engraver; young man; steady and sober; will not go south. Address "Ed.," 817 W. Main St., Enid, Okla.

FIRST CLASS diamond setter on fine jewelry desires position at once; no objection to going out of town. Address "E., 3523," care Jewelers' Circular-Weekly.

EXPERIENCED engraver and salesman, can assist on ordinary jewelry and clock repairing; first class references. "T., 3575," care Jewelers' Circular-Weekly.

SITUATION WANTED by good, practical watchmaker and plain engraver; good set of tools; good references. "Jeweler," 528 Jackson St., Sandusky, O.

ASSISTANT WATCHMAKER would like position or act as first watchmaker; moderate salary; references. M. Jackson, care Detroit Hotel, Mt. Clemens, Mich.

STRICTLY first class watchmaker, with first class tools and references, wishes position; New York City preferred. "H. R., 3332," care Jewelers' Circular-Weekly.

WANTED, by strictly first class watchmaker, position in west or middle west; best of references; 11 years at bench. Address "X.," P. O. Box 524, Sacramento, Cal.

EXPERIENCED salesman, 27, 14 years' in both wholesale and retail jewelry and watch business; salary nominal. Address "X., 3561," care Jewelers' Circular-Weekly.

COLORER, first class on all colors and solutions, desires position; honest, sober; capable of fixing coloring department. Charles Berlin, 231 Eldridge St., New York.

ENGRAVER would like good, steady position with good house; capable of handling fine class of work; west preferred. Address "G., 3513," care Jewelers' Circular-Weekly.

YOUNG MAN, 9 years' experience in retail jewelry business, desires position in retail or wholesale house; willing to travel. "K., 3510," care Jewelers' Circular-Weekly.

YOUNG MAN, 21, thoroughly familiar with jewelry business, five years' experience, desires a position; A1 reference. "Competent, 3579," care Jewelers' Circular-Weekly.

FIRST CLASS watchmaker, with tools, desires position at once; middle age man; competent to handle railroad work. Address "E. H. B.," 45 Charles St., Springfield, Mass.

FIRST CLASS jewelry repairer desires position; can repair all kinds of jewelry; four years' experience; best reference. William Vehs, 778 Hunterdon St., Newark, N. J.

EXPERIENCED WATCHMAKER, with good knowledge of refraction, wishes position where good, clean work is appreciated. "East, 3565," care Jewelers' Circular-Weekly.

FIRST CLASS watchmaker, jeweler and good engraver; all tools; no bad habits, steady; long experience. Conrad Kohler, care Ruff, jeweler, 146 Clinton St., Johnstown, Pa.

PERMANENT POSITION by young man, first class watchmaker, jeweler and monogram engraver; married. Address W. L. Primrose, 125 S. 7th St., Grand Junction, Colo.

WATCHMAKER, engraver and optician, 18 years' experience, desires steady position at good wages; middle or New England States preferred. "H., 3564," care Jewelers' Circular-Weekly.

EXPERT WATCHMAKER, optician and clock repairer, 22 years' experience; all tools and trial case; \$20 a week; honest and sober; good references. Charles Beavis, Pineville, Ky.

WATCHMAKER, engraver and optician wants permanent position; have had first position for past year; can give reference. Address "M., 3528," care Jewelers' Circular-Weekly.

JEWELER, 20 years' experience as first class jeweler and repairer, understand taking place as assistant foreman; best reference. Address "H., 3531," care Jewelers' Circular-Weekly.

WATCHMAKER, engraver and salesman, young man, good appearance, A1 references; New England or eastern State preferred. Address "Grant," 11 Smith Block, Auburn, N. Y.

POSITION WANTED by first class jewelry repairer, new work and setting, clock repairer, and can help on watches; young man; A1 reference. "D., 3547," care Jewelers' Circular-Weekly.

YOUNG MAN, 21, having almost five years' experience with diamond importing house, desires to make a change; can furnish best of references. "R., 2906," care Jewelers' Circular-Weekly.

EXPERT sample maker and designer, capable of taking charge of the shop; steady position preferred to high wages; city references. Address "R., 3535," care Jewelers' Circular-Weekly.

WATCHMAKER and engraver, over 15 years' experience, wants steady position in first class store; nothing less than \$20 per week considered. "H. W. P., 3566," care Jewelers' Circular-Weekly.

FIRST CLASS jewelry engraver, salesman and window dresser, desires position with first class firm, by March 15; best references furnished. "Engraver," 123 E. Broad St., Richmond, Va.

WATCHMAKER and engraver, 30 years' experience on railroad and Swiss watches; no jewelry repairs; state particulars, references. Address "Watchmaker," 103 Broadway, Princeton, Ind.

JEWELER, experienced, all around man, platinum diamond mounter, new and repair work, can also do setting, wishes position; best of references. John Berkowitz, 221 E. Jacob St., Louisville, Ky.

PRACTICAL WATCHMAKER, 28 years at the bench, desires position; nonpareil in repairing all kinds of watches and clocks; salary, \$25 a week. John Brown, 4 Union Square, New York.

WATCHMAKER, with optical diploma, open to engagement at high class work; trained in London; 20 years' American experience; highest references. H. G. Ganney, 81 Puntine St., Jamaica, L. I.

YOUNG LADY, having Maiden Lane reference, desires position as office assistant and general helper with jewelry firm; also capable of selling. Address "J., 3558," care Jewelers' Circular-Weekly.

A MAN with 15 years' experience and thorough knowledge of the diamond trade, wants position in office or jewelry store; can furnish high references. "O., 3538," care Jewelers' Circular-Weekly.

YOUNG MAN, 22 years of age, would like to travel, or keep books to start, for a diamond house; four years' experience in office and on the road. "R. E. M., 3501," care Jewelers' Circular-Weekly.

A1 WATCHMAKER, jeweler and engraver desires a change; Indiana or Illinois preferred, can furnish any reference; positively no bad habit \$21 per week to start. "C., 3546," care Jewelers' Circular-Weekly.

WATCHMAKER, 20 years' experience on high class work, accustomed to taking in and delivering work, desires good position with first class jeweler; not engraver. "R. Y.," 11 South Union St., Rochester, N. Y.

ENGRAVER, young man, desires position with first class engraver, or an opportunity to learn watch work; good script letterer; samples on request; A1 reference. "S., 3517," care Jewelers' Circular-Weekly.

SALESMAN, calling on New York City and out-of-town trade, desires change with A1 job in office or manufacturing house; seven years' experience; highest references. Address "R., 3021," care Jewelers' Circular-Weekly.

FIRST CLASS watchmaker, jeweler and plain engraver, good salesman; competent on high grade watch repairing and estimating on work; best references. Address "Experienced, 3548," care Jewelers' Circular-Weekly.

A FIRST CLASS WATCHMAKER, with many years' experience in high grade adjusting an complicated watch work, wishes to make a change in his position. Reply to Nils Zetterquist, 70 Columbus Ave., Waltham, Mass.

YOUNG LADY desires position with jewelry house; has had seven years' experience and is capable of filling any position in that line; can furnish first class references. Address "T. 3519," care Jewelers' Circular-Weekly.

SILVERWARE SALESMAN, long experience, successful record, large acquaintance New York City, east and middle west, wants position without concern who can handle big business. "Hustler 3532," care Jewelers' Circular-Weekly.

A FIRST CLASS watchmaker, 25 years' experience on high grade American and Swiss watches, wishes a steady position; can start at once in vicinity of New York City. Address "K., 3541," care Jewelers' Circular-Weekly.

FIRST CLASS watchmaker, 14 years' experience, competent on railroad and finest watches, also fair engraver, jeweler and salesman, wants permanent position; best references; good habits. "L., 3556," care Jewelers' Circular-Weekly.

POSITION WANTED by first class watchmaker, 28 years' experience, thoroughly competent in all kinds of watches; good set of tools; first class New York references from best houses. Address "A. D., 3560," care Jewelers' Circular-Weekly.

YOUNG MAN, 25, can assist at watch work, do plain engraving, jewelry coloring and act as a salesman, desires position with good watchmaker, own tools. Address "M., 3557," care Jewelers' Circular-Weekly, 501 Heyworth Bldg., Chicago, Ill.

A YOUNG MARRIED man, age 28, desires position as salesman and window dresser; 12 years' experience; can do plain watchwork, clock and jewelry repairing; New York City preferred. Address "W., 3570," care Jewelers' Circular-Weekly.

A GOOD, experienced manufacturing jeweler, who understands fine and cheap work, has all models and designs necessary to be used, is looking for a position as a foreman and to take charge of a factory. Address "T., 3408," care Jewelers' Circular-Weekly.

FIRST CLASS watch repairer, every kind of difficult watch cases, stone setting, clock repairing, some engraving, can do refracting, making glasses and repair silverware; fast worker. Address "G. H. Clock, watchmaker, General Delivery, New York.

SITUATIONS WANTED.—Continued

A FIRST CLASS manufacturing jeweler and diamond setter, also an A1 repairer and all around man; young, sober and reliable, with good recommendation; northwestern States; retail stores only need apply. Address Robert W. C. Pfaffel, Enid, Okla.

GRADUATE OPTICIAN and jewelry repairer, age 25, thoroughly experienced, desires position; can wait on trade, give correct estimates on all jewelry and optical repairs, and can take entire charge; references. Address "R., 3562," care Jewelers' Circular-Weekly.

WANTED, a position by a jobbing jeweler, who can also do a little setting, polishing, gilding, refining, smelting and wait on trade; willing to go out of town at reasonable salary. Address "N., 3527," care Jewelers' Circular-Weekly, 501 Heyworth Bldg., Chicago, Ill.

WATCHMAKER and graduate optician would like a position in good town in Colorado; have good position, but wife's health demands change; will come on 30 days' trial; best of reference; have tools and trial case; wages, \$22.50 per week. J. T. Little, 317 S. 3d St., Independence, Kans.

SALESMAN, with an established trade of 25 years, would like a position to travel, selling watches, diamonds and jewelry in the States of New Jersey, Pennsylvania, New York, Connecticut and Massachusetts; best of reference given. Address "A. B. C., 3435," care Jewelers' Circular-Weekly.

YOUNG MAN, 24, single, desires permanent position; first class watchmaker, plain engraver and graduate optician; can act as salesman when necessary; own bench and tools, including lathe, etc.; moderate salary; six years' experience; Georgia or Tennessee preferred. Address "J., 3516," care Jewelers' Circular-Weekly.

FIRST CLASS watchmaker, fine letter and monogram engraver and graduate optician; 23 years' experience, five years on railroad watches; several years in present position; do not repair locks or jewelry; Indiana or Illinois preferred; would not go east of Indiana; town 8,000 to 25,000; first class references. Address "S. J., 3383," care Jewelers' Circular-Weekly.

WATERSMITH; energetic, ambitious young man, with a wide experience of 25 years, wishes position as manager, foreman or high class workman; thoroughly competent to handle all branches of gold and silver novelties and hollow ware trades; strictly sober; unquestionable references; moderate wages to start; willing to go anywhere. Apply "X., 3536," care Jewelers' Circular-Weekly.

Side Lines Wanted.

SALESMAN, with office and force in Chicago, wants line of jewelry or kindred line; what have you to offer? Address "A., 3542," care Jewelers' Circular-Weekly.

Help Wanted.

WATCHMAKER, engraver and salesman; steady position; send reference; state age, experience and salary wanted. P. O. Box 453, Wheeling, W. Va.

WANTED, at once, watchmaker and engraver; good opportunity for right man; none but strictly business man need apply. W. F. Cheers, Sanford, N. C.

WANTED, first class watchmaker, optician and engraver; permanent position to the right man in one of the growing cities of the southwest; population about 20,000. Address "A1, 3524," care Jewelers' Circular-Weekly.

WANTED, watchmaker and general man to take charge of small branch store; good references required; young man with some knowledge of French clocks and tools preferred; chance for advancement. Box 118, Stockbridge, Mass.

WANTED, at once, young man salesman for retail jewelry establishment; must be accustomed to handling high class trade. Henry Kohn & Sons, Hartford, Conn.

WANTED, watchmaker, must be first class on railroad and complicated watches and have good reference; permanent position to right man; large store; population, 45,000; state full particulars in first letter. J. Jessop & Sons, San Diego, Cal.

WANTED, first class watchmaker, letter and monogram engraver, one who can do good jewelry and clock repairing preferably, good optician; first class satisfactory references wanted; my position is steady and reliable to good party; salary, \$20 to start; if satisfactory will raise. Apply at once to A. Rabinowitz, Stamford, Conn.

WATCHMAKER and jewelry repairer who can translate from French and German into English, and who knows something about the theory of horology, will be offered desirable position; state age, nationality, education, general qualifications, etc. "R. J., 2314," care Jewelers' Circular-Weekly.

WANTED, reliable person or firm to carry high class line of sterling silver flat and hollow ware in the west from Denver to the coast on commission basis; business already established and only such as have personal acquaintance with the trade need apply; line can be carried in conjunction with first class gold jewelry or kindred line. Address with references, "H., 3509," care Jewelers' Circular-Weekly.

Business Opportunities.

FOR SALE, the patent right to manufacture a roller jewel setter that will set a roller jewel in 30 seconds, or will sell the patent outright. S. W. Christine, Bangor, Pa.

STOCK and fixtures located in western State; annual sales \$12,500; \$5,000 will buy; good run of bench work; good prices. Address "C., 3440," care Jewelers' Circular-Weekly.

A RING FACTORY, doing fine work, and well equipped; a close price will be considered for cash offer; write if interested. Address "N., 3290," care Jewelers' Circular-Weekly.

FOR SALE, on account of sickness, old established jewelry store on Eighth Ave., New York; small capital required; rent very moderate. Answer "V., 3512," care Jewelers' Circular-Weekly.

FOR SALE; an opportunity to buy an established business; county seat; no stock except optical goods and fixtures; best reasons for selling. Address "F., 3553," care Jewelers' Circular-Weekly.

FOR SALE, the old established two window jewelry store on one of New York's busiest avenues, with or without stock, at reasonable price; must be sold at once. M. Hodes, 2168 Third Ave., New York.

WANTED; large jewelry house wants entire production of small manufacturer of 10 karat brooches, rings, scarf-pins and exclusive up-to-date novelties. Box 3525, care Jewelers' Circular-Weekly.

FOR SALE, complete electro-plating plant; solutions and equipment for all kinds of work; a bargain to the right party; must be sold to close an estate. Address Warner Silver Co., 42 Beach St., Bridgeport, Conn.

FOR SALE, leading jewelry store in Iowa County seat; town of 4,500 population, watch inspectors, one competitor; business will bear closest investigation; terms, \$3,500 cash. "Y., 3537," care Jewelers' Circular-Weekly.

JEWELRY STORE for sale, the best location in Paterson, N. J.; profits average \$150 a week; real estate business in southern California compels me to sell. Chas. H. Kelley & Co., 123 Main St., Paterson, N. J.

FOR SALE, on account of sickness, an enameling shop for jewelry, established for 25 years; would also accept a competent man for partner instead; location, Newark, N. J. Address "E., 3448," care Jewelers' Circular-Weekly.

RARE OPPORTUNITY to buy paying jewelry, optical and imported novelties, stock and fixtures, \$3,500; no opposition; 4,000 people; healthy place; Summer and Winter resort; county seat; established over 13 years; sell for cash only. Otto Sange, Bay St. Louis, Miss.

FOR SALE, old established business, 25 years at same stand in one of the best sections of New York, with stock and fine repairing business; can be bought cheap; desiring to retire; will reduce stock to suit; lease has three years to run. Box 3526, care Jewelers' Circular-Weekly.

FOR SALE, jewelry store in busy Pennsylvania town, about 16 miles east of Pittsburg; stock will invoice about \$8,000, mainly watches, movements and diamonds; good watch repairing trade; cheap rent; reason for selling, owner died. Address "W., 3432," care Jewelers' Circular-Weekly.

FOR SALE, control of a patented jewelry novelty (U. S. and foreign patents), a money maker, field unlimited, now being marketed, a good seller, no competition, jewelry factory complete; a clean proposition; only parties of means need apply. Address "H., 3569," care Jewelers' Circular-Weekly.

\$7,000 WILL BUY best jewelry and optical business in good manufacturing town of 11,000 near St. Louis, with rich agricultural country surrounding it; stock can be reduced; will give long lease on store building if desired; I have made money here and so can you. Address "E., 3495," care Jewelers' Circular-Weekly.

IF YOU HAVE a surplus stock of diamonds, watches or jewelry, send them to me and I will send cash for same; all business strictly confidential. E. Noel, 552 E. 46th Place, Chicago, Ill.

FOR SALE, a nice retail jewelry and souvenir business, located on Penn. Ave., Washington, D. C.; stock over \$10,000; will reduce if desired; sale at inventory price or less if purchased outright; owner unable to give the business his personal attention, being disabled. Address "S., 3326," care Jewelers' Circular-Weekly.

PARTNER, who understands the optical business and will invest at least \$1,000 in wholesale optical business established one year in city of 55,000 population; a proposition worthy of your consideration; for full particulars address, "E., 3550," care Jewelers' Circular-Weekly, 501 Heyworth Bldg., Chicago, Ill.

DO YOU NEED MONEY? If so, send your diamonds and watches to me and get quick and liberal returns; highest cash prices paid for entire jewelry stocks; will send our representative if necessary; business confidential; National Bank references. H. Schwartz, 807 Chicago Savings Bank Building, Chicago, Ill.

DO YOU WISH TO RETIRE? Why not turn your entire store or surplus stock into cash? We pay the highest prices, also advance liberal cash amounts on stocks; communicate with us before consulting others; we act quick and strictly confidential. Brooklyn Purchasing Syndicate, 608 Broadway, Brooklyn, N. Y., Telephone, 2328 Williamsburg.

FOR SALE, the well known plant of A. Lounsbury & Son, in full running order, with low rent, consisting of machinery, tools, dies, cutters, hydraulic press, drop presses, foot presses, up-right drills, stock, office fixtures, safes, etc.; this plant is thoroughly equipped to make diamond mountings of all descriptions, both heavy and light, as well as fancy jewelry. Apply to Wales B. Lounsbury, 9 Maiden Lane, New York.

Special Notices.

(Continued from page 83.)

For Sale.

FOR SALE, jeweler's safe, inside dimensions, 24 x 27 x 30. Ford & Carpenter, 2 Maiden Lane, New York.

MEDIUM SIZE jeweler's safe, Mosler make, fire-proof, in good condition; cheap. Apply W. S. Burrows Co., 110 W. 34th St., New York.

CHEAP, if sold soon, watchmaker's bench, lathe, complete set of tools and stock of materials; all in first class condition. O. G. Kelly, Eaton, O.

FOR SALE, new Whitcomb lathe, 10 chucks, Moosler 18 chucks, foot wheel, Boettgers demagnetism, new; gold scale, staking hook, 50 punches, 14 plugs, callpus, countershaft. Address "I., 3571," care Jewelers' Circular-Weekly.

FOR SALE, platform scales, two dynamos for coloring room, three ft. press, gas furnace, electric furnace, rotary shears, four scratch brush heads, bench vise, air pumps. The Chas. M. Robbins Co., Attleboro, Mass.

JEWELER'S FIXTURES for sale; bargain; must be sold; seven straight show cases, one horseshoe case, six wall cases, solid mahogany, plate glass; condition A1; cheap if sold as a whole. For particulars, write Jno. S. Adams, receiver, Asheville, N. C.

Wanted to Purchase.

WE WANT to purchase a good paying retail jewelry business; we have \$10,000 to invest; city must not be less than 25,000 and good climate; give amount of business done, amount of repair work and full particulars in first letter. Address "U., 3544," care Jewelers' Circular-Weekly.

To Let.

TO LET, part of fine light diamond office, moderate rent, for manufacturer's representative. Room 1308, 9-13 Maiden Lane, New York.

PART OF OFFICE, fine light, suitable for engraver, designer or stone setter. Apply, 2 to 4 P. M., Room 412, 38 W. 33d St., New York.

PART OF OFFICE, with large front window, desk room and bench room, including bench. I. Robinson, diamond setter, 12 John St., New York.

Lost.

LOST, a ruby cluster ring, 10 diamonds, on Feb. 14; liberal reward for its return as I have a lot of trouble. L. M. Stern, 47 Maiden Lane, New York.

WORKSHOP NOTES

(Third Edition)

For Jewelers and Watchmakers

PRICE, \$2.50

Published by

THE JEWELERS' CIRCULAR PUBLISHING CO.

11 John Street, corner Broadway, New York

LEARN JEWELERS ENGRAVING

"The Engraving School that Graduates Experts." A fascinating, high-salaried and easily learned trade, taught thoroughly and practically by correspondence. Your instructor is the foremost authority and master workman in the world. We will teach the beginner better engraving by correspondence than he can gain in years of rigid apprenticeship. We will improve the skill of any engraver one hundred per cent. and make him master of the trade. The demand for competent engravers far exceeds the supply. Send for handsome, illustrated prospectus. **PAGE-DAVIS COMPANY,** Suite 10, 90 Wabash Avenue, CHICAGO.



Case Screw Washer **URICH PERFECT FITTING**

Case Screw Washer

Easily adjusted and holds the movement securely even when case shoulder is worn away. Prices: Gross, \$1.50; Package, 4 doz. assorted, 50c; single doz., 15c.

For sale at all material houses or direct

S. URICH, P. O. Box 1942, New York City

THEBERATH & CO., Inc.

Manufacturers of unusual, exclusive and salable designs in 14k. gold

**Brooches, Festoons, Handy Pins,
Barrettes, Pendants, Veil Pins,**

in beautiful plain patterns, or set with precious and semi-precious stones.

KENT & WOODLAND, SELLING AGENTS

12 John Street,

NEW YORK CITY

Connecticut.

TRADE CONDITIONS.

General reports from various parts of the State of Connecticut indicate that business is beginning to improve appreciably. An increase of seven hours weekly in the working time at the factory of the Waltham Watch Co., Waltham, Mass., will go into effect on Monday, March 9, according to notices which have been posted at the mills. This will meet all demands, while 3,500 hands are employed. Similar encouraging reports come from her quarters throughout the State.

W. E. Porter has assigned to the New Haven Clock Co., New Haven, a patent which he was recently granted on a clock.

President Lee Roberts, of the Bristol Business Men's Association, was one of the guests at the annual banquet of the New Britain Men's Business Association, held a short time ago.

Henry L. Wade, Waterbury, has been appointed treasurer of the Anti-Tuberculosis League of Connecticut and has already received many handsome checks for the worthy object of that organization.

Leo C. Herr, for several years in the employ of the New England Watch Co., died, Feb. 23, at his home in Waterbury, of appendicitis. The deceased was 36 years of age, and is survived by a widow and six children.

The Landers, Frary & Clark Co., New Britain, has offered a reward of \$500 for information which shall lead to the arrest and conviction of the thieves who recently stole \$1,000 worth of silver in bars from the concern.

E. G. Burnham, Bridgeport, well known in the trade, and who has been seriously ill, is reported convalescent. Some apprehension as to his recovery was felt some days ago, owing to Mr. Burnham's advanced years.

Gen. George H. Ford, New Haven, ex-president of the Connecticut branch of the Sons of the Revolution, was one of the guests at a banquet given on Washington's birthday, in New Haven. Many notable speakers were heard.

Orlando Dunn, in the employ of the R. Wallace & Sons Mfg. Co., Wallingford, while working near an open fire in the forging room, on Monday of last week, sustained painful burns about the hands and arms by a spark which blew up and set fire to his clothing.

At the banquet of the Meriden Business Men's Association, held on Monday of last week, President George H. Wilson, of the International Silver Co., acted as chairman of the reception committee. George M. Curtis and Major W. S. Lyon were members of the committee.

J. W. Cadden, president and treasurer of the Plant-Cadden Co., jewelers and opticians, of Norwich, has the sympathy of his many friends in the trade, owing to the recent death of his mother. The deceased was a native of Bruck, Nuremberg, Bavaria, and was about 75 years of age.

Mrs. Emma Stroebel Curran, Waterbury, has brought suit against her brother, Geo. J. Stroebel, for \$2,500, and an attachment for \$3,500 has been made on property owned by the defendant. The plaintiff alleges that the defendant owed \$2,500 on Feb. 8, 1905, to their late brother, Christian Stroebel, and that the money was loaned to

George Stroebel to pay taxes on insurance. Prior to Christian Stroebel's death, it is alleged, he assigned the claim against his brother to the plaintiff.

The Waterbury Clock Co.'s Aid Association, Waterbury, which recently celebrated its 25th anniversary by an entertainment and ball, was first organized in December, 1882, for the purpose of paying a weekly benefit to employes who were incapacitated by illness or accident. The total amount disbursed by the association since its organization is nearly \$30,000. The present officers are: President, P. B. Reese; vice-president, G. F. Moore; secretary, R. Pierce; treasurer, S. Martin.

Frank Tarcheara, a negro, 25 years of age, attempted to steal a ring from the store of Wm. T. Steven, 203 Trumbull St., Hartford, Feb. 25, by concealing it under his tongue. He entered the store and said he wished to purchase an engagement ring. After inspecting several, he decided that he would consult his fiancée. He handed a ring back and the jeweler at once recognized it as a substitute of the genuine article, which was later found in the unique location mentioned above, when he was searched at the station house.

Louis B. Ammerman, who was arrested in New Haven, several days ago, after cashing worthless money orders throughout the east, was sentenced, Feb. 25, to five years' imprisonment by Judge Platt, in the United States court. Ammerman was wanted in Bridgeport and many other cities. Among those whom he defrauded in Bridgeport were the Davis & Hawley Co., Max Wittstein and Henry C. Reid. At each of these establishments he made purchases and offered in payment the worthless money orders. In most instances he received not only the goods, but the change above the amount of his purchase.

Louisville, Ky.

Miss Pearl Geller, a pretty young actress, and Walter Frick, a young jeweler of St. Louis, were married, last week, in this city, the culmination of a romance which began three weeks ago.

Letzler, Lorseh & Co., of this city, through their attorneys, Charuth, Chatterson & Blitz, are offering creditors a settlement of 50 per cent., of which part is to be paid in cash and the balance on time. The recent financial stringency found the partners in a position where, though apparently solvent, they were unable to meet their obligations, for lack of cash or ability to convert the assets, and rather than make an assignment, go through bankruptcy, or take any proceedings of this sort, they decided to submit to the proposition of settlement on the above-mentioned basis. The liabilities are estimated at about \$10,000, while the value of the stock, machinery, fixtures, etc., is estimated at between \$11,000 and \$12,000, and the firm has book accounts and bills receivable amounting to about \$2,500.

The safe of the National Drug & Mercantile Co., Bluff City, Kans., was blown open a few nights ago and a number of watches and a small amount of cash were stolen.

Washington, D. C.

The *Post* of this city recently published an interview with Thomas Lees, a well known jeweler of Hamilton, Ont., who has been stopping at the Raleigh, in which Mr. Lees explained the condition of the jewelry trade in Canada since the financial disturbance of last November, saying that conditions were now much improved and there was again plenty of money in circulation.

In the action brought by the wife of Robert Castelberg, against the Castelberg National Jewelry Co. for an accounting, Judge Gould, of Equity Court, No. 2, has granted an order compelling the complainant to give security for costs. Mrs. Castelberg brought the action as agent for her husband, who disappeared from Washington in August, 1905. All liabilities is absolutely denied by the defendant, which claims to owe nothing to the missing man.

As recently noted in THE CIRCULAR-WEEKLY, the will of the late Norman Galt was admitted to probate recently and by its provisions Mr. Galt's widow, Edith Bolling Galt, is made his sole legatee and executrix. She has now notified the trade that the business owned by her husband and conducted under the style of Galt & Bro., at 1107 Pennsylvania Ave., will be continued as heretofore under the same name without change in policy or change in the staff employed.

The Supreme Court last week handed down a decision on the right of Customs Collector Leach, of Cleveland, to seize in New York the jewelry of the late Mrs. Cassie Chadwick, which was believed to have been smuggled by her. Mrs. Chadwick had hypothecated the jewelry with J. W. Friend, of Pittsburg, who had turned it over to H. H. Larkin, from whom it was seized. The court held that Mr. Leach could not properly take possession of the property in New York.

The House of Representatives has received a favorable report on the bill to establish a biological and fish cultural station in the second district of Iowa, the action of the Committee on Fish and Fisheries being based on the report of a special committee sent to investigate the fresh water bivalves from which pearl buttons are made and which produce fresh water pearls. The report says that the establishing of the Iowa station will result in giving an impetus to the pearl button industry in several parts of the country.

Merchants in the towns in the Mohawk and Hudson valleys, in trying to get something for nothing, got caught in a bunco game which has made them a little wiser, even if their bank accounts have been hit. A clerical-looking gentleman had a scheme that proved a "taker." The scheme was to put in a stock of jewelry to be given away to customers, like trading stamps. The merchants were to sell the jewelry if they could, and at the end of the year the remaining stock was to be taken off their hands and no payments were to be made until the end of the year. Now notes are beginning to turn up against the merchants, and it's a case of settle or stand a lawsuit. The merchants supposed they signed contracts, but in reality they signed notes for which payment is now demanded.

THE OPTICAL REVIEW

FOR MARCH

- ¶ A High Class Magazine for Opticians and Optometrists.
- ¶ A Worthy Representative of an Important Industry.
- ¶ Publishes the Best Optical Literature Procurable and All the News.

THE OPTICAL REVIEW is the greatest aid to the advancement and progress of the optical department, the optician and optometrist.

No jeweler with an optical department can afford to be without it.

CONTENTS FOR MARCH

"Correcting the Muscular Anomalies." By Howard C. Doane, Boston, Mass.

"Measuring the Working Distance." By E. Le Roy Ryer, New York City.

"Prisms in Ocular Practice IX." By John C. Eberhardt, Dayton, Ohio.

"Nature of Light, Wave Theory, Propagation of Light." By Howard D. Minchin, Ph.D., Rochester, N. Y.

"The Optometrist's Obligations to Society." By John L. Beard, Charleston, W. Va.

"Mal-Assimilation: the Cause of High Ametropia." By A. C. Roberts, Red Wing, Minn.

"Eyesight of the Poorer City Children." By H. Wright Thomson, M.D., Glasgow, Scotland.

Digest of Current Optometrical Literature—Optometrist's Catechism—Questions and Answers—Examination Room Work—Making the Sale—News of the Month—Meetings and Conventions—Optometry Legislation—Editorials—Patents—In a Light Vein.

¶ We exclusively extend to subscribers of THE JEWELERS' CIRCULAR-WEEKLY the privilege of subscribing to THE OPTICAL REVIEW at one-half price—50 cents per year. If you have not already mailed your subscription, simply sign and return the attached form, sending no money in advance.

¶ Carefully read the blank below. Send at once and get the February issue.

ISSUED MONTHLY.

SUBSCRIPTION, \$1.00 PER YEAR.



Published by
THE JEWELERS' CIRCULAR PUBLISHING CO.,
11 John Street, cor. Broadway, New York

Commence _____

N. B.—This subscription will be billed concurrently with your Jewelers' Circular subscription. It can be stopped at any time.

Please enclose your business card or printed address

190

Send "THE OPTICAL REVIEW" to my address until otherwise ordered, for which I agree to pay **50 cents a year** as a special introductory combination price with my subscription to the JEWELERS' CIRCULAR-WEEKLY.

Name _____

Street _____

City _____

State _____

Constitution and By-Laws of the Indiana Retail Jewelers' Association.

INDIANAPOLIS, Ind., Feb. 26.—The following is the text of the constitution and by-laws adopted by the Indiana Retail Jewelers' Association:

CONSTITUTION.

Article I.—Name.

This association shall be called the Indiana Retail Jewelers' Association.

Article II.—Objects.

The objects of this association shall be to unite the retail jewelers of the State in a sentiment promotive of the highest welfare of the trade; to cause the elimination of unmercantile methods and practices; to encourage the supremacy of standards of truth and honesty in all jewelry and related products; to protect the trade against agencies and influences subversive of its highest development and prosperity; to promote legislation opposed to untrue or deceptive quality marks on jewelry manufacturers; to foster the recognition of the fraternity of interest between all identified with the progress of the jewelry and kindred arts; to co-operate in promoting improved conditions of education, apprenticeship and employment, and in general to promote measures calculated to redound to the material and moral advantage of retail jewelers.

Article III.—Membership.

Section 1. This association shall consist of active, associate and honorary members.

Sec. 2. Retail jewelers only (those persons whose exclusive or principal business is the keeping of a retail jewelry store, and who are practical watchmakers or regularly employing one, and who maintain a bench for repair purposes) shall be eligible to active membership.

Sec. 3. Any member of the jeweler's art, who shall have attained the age of 21 years, residing in the State, in charge of a retail jewelry business or in the employ of another, shall be eligible to associate membership, but shall not vote or hold office.

Sec. 4. Persons not retail jewelers, but identified with their interests, on whom it is desired to confer the compliment, may be elected honorary members. They shall not, however, be required to contribute to the funds, nor shall they be eligible to hold office or vote at the meetings.

Article IV.—Officers.

The officers of this association shall be a president, two vice-presidents, a general secretary, a treasurer and an executive committee consisting of five members, representing as nearly as may be the various sections of the State (and of which the president, vice-presidents, general secretary and treasurer shall be *ex officio* members), all of whom shall be elected annually, and shall hold office until the election of their successors.

Article V.—Time of Meeting.

The regular annual meeting of this association shall be held at Indianapolis on the second Tuesday of February of each year.

Article VI.—Duties of Officers.

Section 1. The president, or in his absence or inability to serve, the vice-presidents in their order, shall preside at all meetings of the association, call special meetings at the written request of 10 members, fill any vacancies occurring in any office from any cause, appoint all special committees, present at each annual meeting a report on the affairs of the association and perform such other duties as pertain to the office. The president shall appoint five delegates (with power to name alternates) to attend the annual meeting of the National Association of Retail Jewelers of which he shall be chairman *ex officio*; he shall also appoint five delegates to each State Jewelers' Association of adjacent States.

Sec. 2. The general secretary shall keep a record of all the proceedings of the association. He shall read all communications, conduct all correspondence of the association, at each annual meeting render a report of the duties performed by him since the last annual meeting, and perform such other duties as the association shall direct. He shall notify members of committees of their appointment and election, and furnish each member of the committee with the names of his associates on said committee. He shall receive and collect all moneys for the association, giving re-

ceipts for the various amounts, keep a correct account thereof, and pay the same to the treasurer, taking his receipt therefor. He shall give a sufficient bond within 60 days after his election, subject to the approval of the president.

Sec. 3. The treasurer shall have charge of all the funds of the association, for which he shall be personally responsible, shall pay all bills when countersigned by the president and general secretary, and report the state of the treasury, when called upon by the president or the executive committee. He shall give a sufficient bond within 60 days after his election, subject to the approval of the president.

Sec. 4. It shall be the duty of the general secretary and the treasurer to turn over to their successors, without unnecessary delay, all papers and property of the association committed to their care.

Sec. 5. The executive committee shall have full power to act for, and shall have general charge of the affairs of the association in the intervals of the regular annual meetings, provided that the action of such committee shall not contravene instructions of the association; and its action may at any time be overruled by the association. The committee shall organize by the adoption of rules, and with such officers and committees as it shall deem desirable or necessary. Five members shall constitute a quorum.

Article VII.—By-Laws.

This association may establish for its future government and regulation such by-laws, not in conflict with this constitution, as may be deemed proper and desirable.

Article VIII.—Amendments.

Every proposition to alter or amend this constitution shall be submitted in writing and received at an annual meeting, and may be voted for at the next annual meeting, when, upon receiving the votes of three-fourths of the members present, it shall become part of this constitution.

BY-LAWS.

Article I.—Quorum.

Fifteen members shall constitute a quorum.

Article II.—Members and Dues.

Section 1. All applications for memberships shall be made in writing (accompanied by a fee of \$2) to the general secretary, and shall be referred by him to the executive committee, who shall report such as are approved to the association at its next session, when the applicants may be elected by a two-thirds vote of the members present.

Sec. 2. Every member shall pay annually into the hands of the general secretary the sum of \$1. Anyone in arrears at the annual meeting shall not be entitled to vote, and any one neglecting to pay said dues for three consecutive years may be dropped from the roll of membership.

Sec. 3. The association shall have power to expel a member by a two-thirds vote; but the vote shall not be taken until the next annual meeting after the charges have been preferred and the accused shall be notified of the charges and specifications made against him.

Sec. 4. Resignation of membership shall be made in writing to the general secretary, but no resignation shall be accepted from anyone who is in arrears to the treasury.

Article III.—Standing Committees.

Section 1. The association shall elect all standing committees (of which the president shall be an *ex-officio* member), each to consist of three members, viz.: Committee on trade interests, committee on legislation, committee on qualities, committee on membership and committee on deceased members.

Sec. 2. The committee on trade interests shall report at each annual meeting such observations and information upon questions of trade welfare as the committee shall deem of interest, together with recommendations for action.

Sec. 3. The committee on legislation shall report on the nature and effects of legislation enacted during the year affecting the interests of retail jewelers and what additional legislation is proposed or desired, with related recommendation.

Sec. 4. The committee on qualities shall report to the association annually, or oftener in its discretion, on the qualities of jewelry products in the

market, the presence or absence of quality marks, the truth or falsity of such marks, together with such other information or such recommendations as may pertain to the subject.

Sec. 5. The committee on membership shall, in co-operation with the general secretary, endeavor to secure as members all eligible retail jewelers in the State.

Sec. 6. The committee on deceased members shall annually make due reference to members who have died during the year.

Article IV.—Publication of Proceedings.

The proceedings of the association, the roll of officers, committees and members shall be published annually under the supervision of the general secretary, and a copy of the proceedings sent to each member of the association who is not in arrears for annual dues.

Article V.—Local Secretary.

Section 1. A local secretary shall be elected at each meeting, who shall reside at or near the place where the next meeting is to be held. He shall have general charge of arrangements for the meeting, including arrangements for any exhibit of jewelry products, should the association authorize such exhibit.

Article VI.—Local Organizations.

All local or county organizations of retail jewelers shall be entitled to three delegates as their representatives to the annual meetings, and are requested to send annually written reports of their work during the year.

Article VII.—Order of Business.

The order of business, unless otherwise ordered, shall be as follows:

1. Reading the minutes.
2. Applications for membership.
3. President's address.
4. Reports of officers and committees.
5. Unfinished business.
6. New business.
7. Election of officers.
8. Installation of officers elect.
9. Adjournment.

Article VIII.—Amendments.

Section 1. These by-laws shall not be suspended without the consent of two-thirds of the members present.

Sec. 2. Any amendment to these by-laws must be made in writing, read before the association at one sitting, and laid over to a subsequent sitting, when, upon receiving the votes of two-thirds of the members present, it shall become a part of these by-laws.

RESOLUTIONS.

Resolved, That we record our condemnation of all marks on gold and silver products which are not indicative of their true quality, and that we heartily approve of the new federal stamping law relating to gold and silver jewelry, believing that it will aid materially in the promotion of honest qualities and honest methods in trade.

Resolved, That we favor such action as shall secure to the retail jewelry trade exemption from the unfair, unjust and ruinous competition by retail mail order concerns, department stores and similar alien elements, and we call upon manufacturers and wholesale dealers to lend their assistance in such manner as shall recognize the rights and interests of the retail jewelry trade, and afford to the trade the full measure of protection to which it is entitled.

Resolved, That we condemn the practice of retailing by wholesale dealers as fraught with great and widespread injury to retail jewelers and as being fundamentally unjust in that it involves competition between the wholesaler and retail dealer who buys from such wholesaler. We therefore regard the practice as being hostile to the welfare of the jewelry trade, when such retailing is not regularly maintained as a separate business apart from the wholesale business.

Resolved, That it is the sense of this association that retail jewelers should confine their purchases of watches, clocks, jewelry and kindred articles, as far as practicable, to those wholesale dealers and manufacturers who restrict their sales to retail jewelers, or who sell under those conditions only which enforce retail prices recognized by the retail trade as reasonable and just.

Resolved, That we refuse to purchase goods without the name or mark of the manufacturers on same.

Resolved, That we condemn the common practice of selling diamonds, watches, clocks and jewelry by persons other than jewelers and commonly known as curbstone dealers, or by employes of jewelry jobbing house.

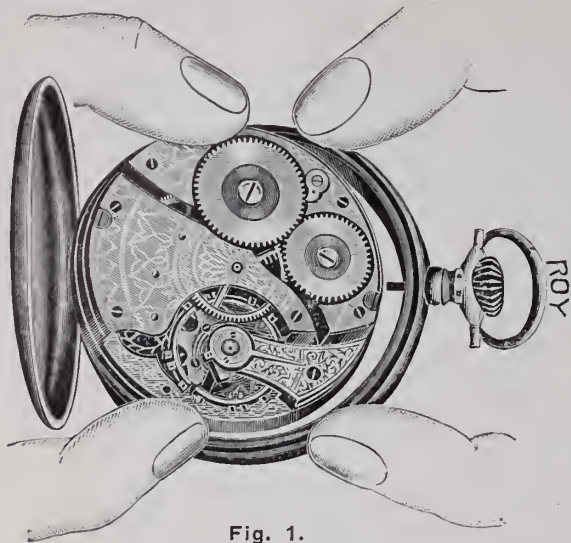
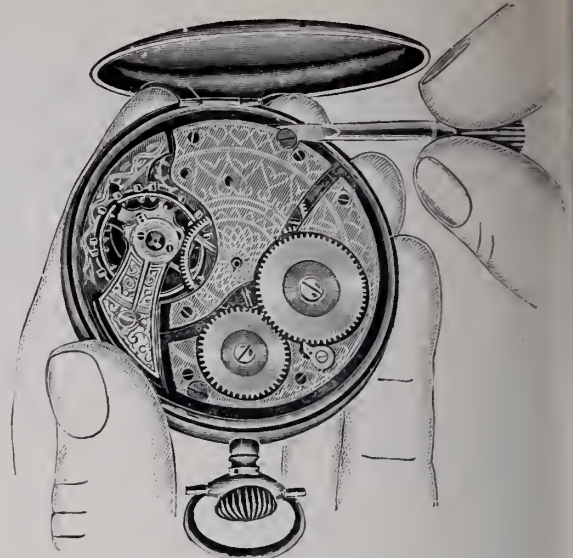

Fig. 1.

The
Ægis
 Case
 Patented



ROY
Fig. 3.

¶ The Ægis is a new creation in gold case making. The center and bezel are in one. Instead of having the ordinary Cap, this case is provided with a rigid metal movement Cup, held friction tight in position. This Cup gives protection to the movement such as cannot be secured with the conventional jointed cap, while dust is thoroughly excluded from the front by means of the one piece center and bezel.

¶ To fit movement, first properly adjust the hands; then pull out crown as usual, and insert movement from back of case, (see fig. 1). After winding square is properly fitted, the movement should be pressed down, so that it will be held in proper place by the spring in the case center. The movement cup should then be fitted.

¶ To take out movement, remove the movement cup (shown in fig. 2), by raising it near the pendant; pull out crown to release the square; lift out movement by means of case screw nearest joint (see fig. 3); withdraw movement from square and case.

Made only
by



Fig. 2

Made only
by

ROY WATCH CASE COMPANY

SAN FRANCISCO OFFICE
704 Market Street

21-23 Maiden Lane
NEW YORK

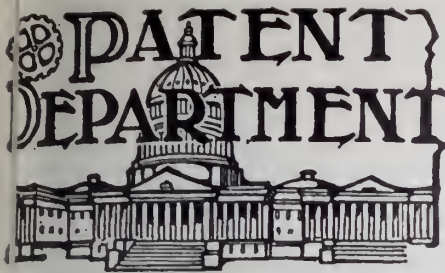

IN WHICH IS CONTAINED A LIST OF THE LATEST PATENTS GRANTED BY THE UNITED STATES AND GREAT BRITAIN, THE UNITED STATES PATENTS THAT HAVE EXPIRED AND THE REGISTERED TRADE-MARKS.

UNITED STATES PATENTS.

ISSUED FEB. 25, 1908.

79,881. BRACELET. SIGMUND L. LEDERER, Providence, R. I. Filed April 17, 1907. Serial No. 368,754.

In a bracelet two hollow wings hinged together, cap fixed in one wing and provided with an open-

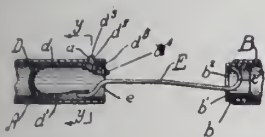

ing a spring loop mounted in the other wing, a notch upon one end of the loop adapted to engage the cap, a guide rod upon the other end of the loop traversing the opening, and a hook upon the end of the guide rod within the first-mentioned wing.

79,912. FOUNTAIN PEN. PERCY P. SANFORD, Bratenahl Village, O. Filed March 8, 1907. Serial No. 361,206.

In a fountain-pen, the combination of a pen holder providing a reservoir for ink, a pen carried by said pen holder, a feeding tube extending from the reservoir toward the point of the pen and terminating beneath it, said feeding tube having flattened portion adjacent to the pen but separated



therefrom a substantial distance, and the duct through the feeding tube terminating in said flattened portion some distance from the lower end thereof, whereby a globule of ink may accumulate on said flattened portion and be delivered to the pen.

879,924. ELECTRICAL APPLIANCE FOR CLOCKS. HARRY O. SWEDBERG and AMOS T. DURBIN, Rossville, Ill. Filed Oct. 11, 1906. Serial No. 338,530.

In an apparatus of the class described, the com-

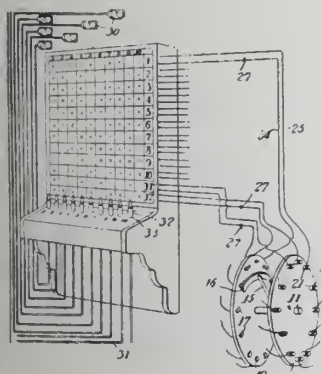

ination with two fixed annular spaced series of contacts, each terminating in a binding post, a clock-actuated spring bridging contact ar-

ranged to successively bridge the opposing contacts of the two series, a switchboard having rows of jacks, the number of rows corresponding to the number of contacts in the annular series, passage through the tank and to press the excess of liquid therefrom, a device for removing from one of the last named belts, the adhering it has removed from the articles, and mechanism for driving the belts.

880,209. ELECTRICALLY-OPERATED CLOCK. HARLEIGH GILLETTE, Chicago. Filed March 27, 1907. Serial No. 364,829.

The combination with a master clock movement, of a secondary clock motor, time-indicating means, connections between the time-indicating means and said secondary clock motor, electrical connections including the motor, means controlled by the movement of the master clock movement for regularly and alternately setting up two different electrical

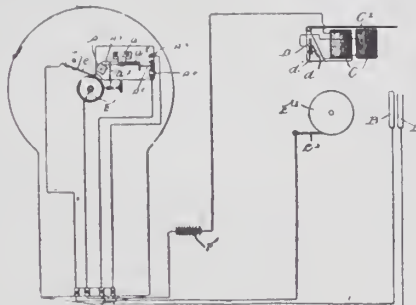

states in the connection, said secondary clock motor being constructed and arranged to be operated in the same direction during each of said electrical states, mechanical means operatively driven by the movement of the motor for interrupting each electrical state after a predetermined movement, whereby the motor is stopped, and mechanical means operatively driven by the motor whereby such movement of the motor shall set devices in the secondary clock in such position that the motor can respond to and be moved by the next succeeding electrical state in the connections.

DESIGNS.

399,156. VESSEL. JOHN J. HEEBY, Moundsville, W. Va., assignor to the Fostoria Glass Co.,



Moundsville, W. Va. Filed Dec. 14, 1907. Serial No. 406,569. Term of patent 14 years.

TRADE-MARKS REGISTERED FEB. 25, 1908.

67,959. WATCHES. SOUTH BEND CO., South Bend, Ind. Filed Oct. 29, 1907. Serial No. 30,857. Published Dec. 24, 1907.

BRITISH PATENTS.

(ABRIDGMENTS OF SPECIFICATIONS, 1906, FROM The Illustrated Official Journal.)

ISSUE OF FEB. 12, 1908.

23,507. BROOCH PINS. H. A. IVES and D. W. JEFFERY, both of Colchester, Essex. Oct. 23. In safety brooch fastenings consisting of a U-shaped piece of spring metal which is threaded

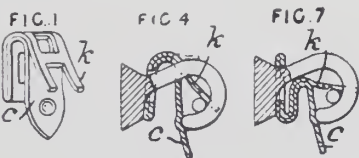

on the hook, an additional bifurcated limb k is provided and engages the upper part of the hook to prevent lateral displacement. The device is formed from a strip of spring metal doubled upon

itself and then bent to a U-shape, the free ends c, k being caused to diverge.

23,630. CLOCKS. STEFAN RITTER VON GRUDZINSKI, Krakau, Galicia, Germany. Oct. 24. Period for granting patent not yet expired.

Clocks Combined With Time-Checks for Games; Stop Mechanism.—The clockwork is adapted to indicate separate short intervals of time, in connection with the use of billiard tables, etc., by means of a pointer 6 on a dial 8, and the sum of such intervals by another pointer on a separate dial, a device being provided for stopping the clockwork and zeroizing the pointer 6. A sleeve 17 carrying the pointer 6 is driven by friction wheels 12, 16 through gearing 11, 10 from the shaft 5 of the clock-work, the wheels 11, 12 being mounted on

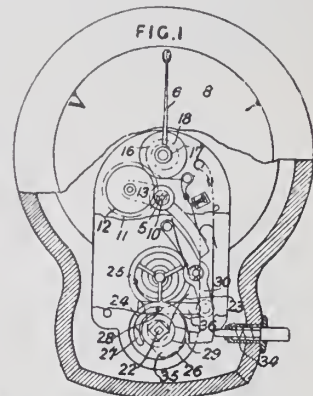

the lever 13 which is pivoted on the shaft 5. The sleeve carrying the second pointer is concentric with the sleeve 17 and is geared to the shaft 5. To stop the clock when the time expires, the spindle 22 and disk 28 are turned to the left by means of a special key, so as to apply the spring 23 to the balance wheel 25. The push 34 is then operated and rocks the spring-actuated lever 30; the nose of that lever enters the notch 29 in the disk 26, and the upper arm engages and turns the lever 13, thereby disengaging the friction wheels 12, 16 and allowing the spring 18 to return the hand 6 to zero. The clock is restarted by turning the spindle 22 to the right, when the spring 24 wipes the balance wheel. A pin 28 works in a slot 27 in the disk 26, and a triangular arm 35 on which the spring-actuated arm 36 bears, ensures the full turning of the spindle 22 in either direction.

Complete specifications accepted Feb. 5, 1908. 1907.

18,209. COMBINED CIGAR CUTTER, MATCH BOX AND ASH TRAY. ZORN.

24,007. HAT-PIN GUARD. BOHME.

26,047. HAIR-CRIMPER. WILCOX.

Applications filed Jan. 27 to Feb. 1, 1908.

1,780. BUCKLE. BARTHOLOMEW JACOB, Birmingham. Complete specification.

1,808. HAT PROTECTOR AGAINST HAT-PINS. J. H. EDIS, Enfield, Middlesex.

1,874. CASE FOR EYEGLASSES OR JEWELRY. W. G. OAKES, Manchester.

1,963. NECKTIE FASTENER. FRANK THEAK, London.

1,991. SNUFF BOX. JOSEPH WALKER, Birmingham.

2,053. HAT-PIN LOCKING DEVICE. F. H. DARLEY, London.

2,164. TEA INFUSER. RUDOLF WINTERNITZ, London.

2,199. WIRE FINGER-RING. ALFRED KRAUSE, London.

2,249. HAIR-PIN. JOSEF LEICHT and JULIUS MAYER, London. Complete specification.

2,256. HAT-PIN. D. L. SALZEDO, London.

2,283. CLASP. M. W. SCHLOSS, Manchester. Complete specification.

2,316. TIME-RECORDER. H. R. SANDERS, London.

2,327. NECKTIE SUPPORT. N. D. NELSON, London. Complete specification.

The stock of the late A. B. Hubermann, Omaha, Neb., is being disposed of at a special reduction sale.



WALTHAM JEWEL SERIES WATCHES



DIAMOND; NICKEL;

17 diamond and ruby jewels; both balance pivots running on diamonds; raised gold settings; steel escape wheel; exposed sapphire pallets; compensating balance, adjusted; meantime screws; patent Breguet hairspring, hardened and tempered in form; patent micrometric regulator; tempered steel safety barrel; gold train; exposed winding wheels.

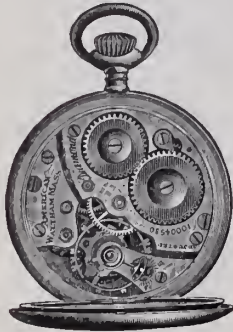

RIVERSIDE; NICKEL;

17 fine ruby jewels; raised gold settings; steel escape wheel; exposed sapphire pallets; compensating balance, adjusted; meantime screws; patent Breguet hairspring, hardened and tempered in form; tempered steel safety barrel; red gold center wheel; exposed winding wheels.

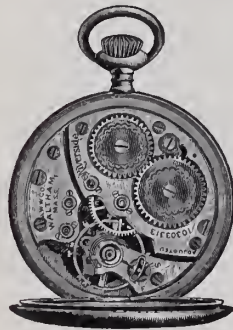

RUBY; NICKEL;

15 jewels; raised settings; exposed pallets; compensating balance; meantime screws; patent Breguet hairspring, hardened and tempered in form; tempered steel safety barrel; exposed winding wheels.

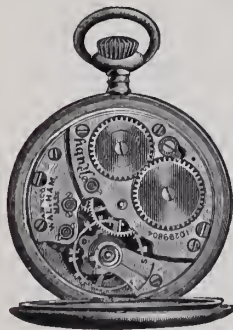

HUNTING OR OPEN FACE

These movements may be obtained in a great variety of Gold Cases, from Plain Polished to the most elaborately Engraved, Carved and Enameled.



Movements Manufactured and Guaranteed by
WALTHAM WATCH COMPANY
WALTHAM, MASS.



THE HOROLOGICAL REVIEW

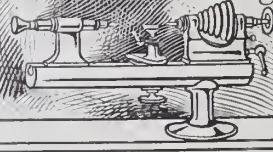

PRACTICAL POINTS ON THE LATHE

Its Manipulation in the Art of Watch Making.
(Written Expressly for THE JEWELERS' CIRCULAR-WEEKLY.)

(Continued from issue of Feb. 19.)

QUESTION:—When we desire to estimate the circumference of a circle by what figures we multiply the diameter?

ANSWER:—By 3.14.

QUESTION:—Do we always multiply by these figures?



FIG. 16.

ANSWER:—Yes; they are a fixed quantity.

QUESTION:—Having the circumference expressed in millimeters or any other measure, how do we obtain the linear length of one degree on any given circle?

ANSWER:—By dividing the circumference by 360, the number of degrees in every circle.

QUESTION:—If the distance of each pallet

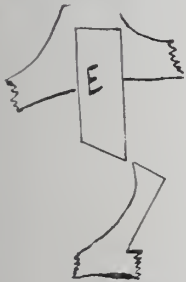

FIG. 17.

entering corner from the pallet staff center measured 2.5 millimeters, what pallet type would this indicate?

ANSWER:—The equidistant.

QUESTION:—If the distance from the locking corner of a pallet measured 2.8 millimeters, figure out the linear length of two degrees of lock.

ANSWER:—
Radius, $2.8 \times 2 =$

Diameter, $5.6 \times 3.14 =$
Circumference, $17.58 \div 360 =$
Size of one degree, $.05 \times 2 =$
Size of two degrees, .10 millimeters (nearly).

QUESTION:—If the distance from a pallet's lowest locking corner to the pallet staff center measured three millimeters, figure out how much three degrees of lock would represent.

ANSWER:—
Radius, $3 \times 2 =$
Diameter, $6 \times 3.14 =$

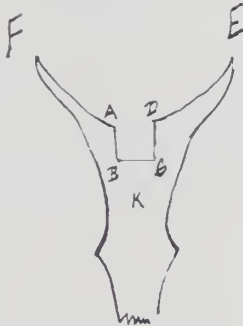

FIG. 18.

Circumference, $18.84 \div 360 =$
Size of one degree, $.05 \times 3 =$
Size of three degrees, .15 millimeters (nearly).

QUESTION:—Estimate four degrees of lock on a pallet whose locking corner is 3.5 millimeters from the pallet staff center.

ANSWER:—
Radius, $3.5 \times 2 =$
Diameter, $7. \times 3.14 =$
Circumference, $21.98 \div 360 =$
Size of one degree, $.06 \times 4.$
Size of four degrees, .24 millimeters (nearly).

QUESTION:—Explain the term "receiving pallet."

ANSWER:—It is applied to that pallet over whose impulse face a tooth slides in order to enter between the pallet jewels—that pallet which receives the tooth on its locking face previous to its entry between the pallet stones. It is also termed the entering pallet. (See R, Fig. 16.)

QUESTION:—What is meant by "discharging pallet"?

ANSWER:—That pallet over whose impulse face a tooth slides in order to make its exit outside the pallet stones. It is also termed the exit pallet. (E, Fig. 17.)

QUESTION:—What is the lever notch?

ANSWER:—The slot in the lever A, B, C, D (Fig. 18), and into which the roller jewel enters.

QUESTION:—What is meant by the expression "corner of notch"?

ANSWER:—That part of the notch marked A D (Fig. 18).

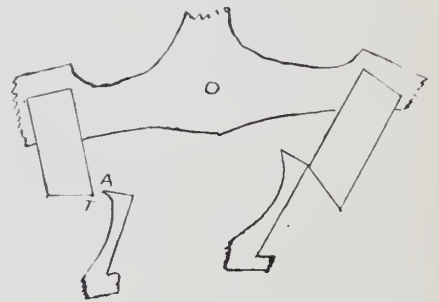

FIG. 19.

QUESTION:—To what does the term "horns of lever" refer?

ANSWER:—To the sweep of the horns F to A and D to E (Fig. 18).

QUESTION:—Where is the guard pin situated?

ANSWER:—The guard pin is inserted directly behind the lever notch K, Fig. 18.

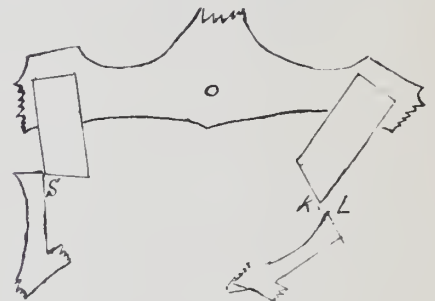

FIG. 20.

QUESTION:—What is the purpose of the guard pin?

ANSWER:—It acts as an important feature of the safety action.

QUESTION:—When specifications are given for escapement drafting, the space which separates the edge of the roller table from the guard pin is given, as of so much of a degree. State from what point this space is measured.



In every country on the globe there is a demand for the

ELGIN WATCH

Just now, in response to extensive advertising, the demand is for the G. M. Wheeler Movement.

To take advantage of this popular tide as it runs, every jeweler should have the G. M. Wheeler grade Elgin Watch in three sizes, 18, 16 and 12—particularly the smaller sizes in the thin model.

See jobbers list for prices or write the Company.

Send for Elgin art booklets, "Timemakers and Timekeepers" and "The Watch."

ELGIN NATIONAL WATCH COMPANY,

Factories: Elgin, Ill., U. S. A.
General Offices: 131 Wabash Ave., Chicago.

New York Office: 11 John St.
San Francisco Office: 734 Market St.

ANSWER:—It is measured from the pallet off center.

QUESTION:—As the pallet and tooth locks are likewise estimated from the pallet off center, does any relationship exist between the pallet lock and the space separating the guard pin from the edge of the roller table?

ANSWER:—Yes; quite a vital relationship, we shall later explain.

QUESTION:—From what point is the depth of the notch in the lever measured?

ANSWER:—It is also measured from theillet staff center.

QUESTION:—To what part of a single roller table is the term "crescent" applied?

ANSWER:—To the circular cutting directly in front of the roller jewel.

QUESTION:—What comprises the safety motion in a single roller escapement?

ANSWER:—The guard pin, roller jewel, riner of notch, roller table, banking pins.

QUESTION:—What does the term "drop," as applied to an escapement, imply?

ANSWER:—The term "drop" as applied to the escape wheel has reference to the space through which the escape wheel moves after being discharged by a pallet; drop or free flight of the wheel exists until another tooth becomes locked on the face of the opposite pallet.

QUESTION:—How many kinds of drop have we in an escapement?

ANSWER:—Two—inside and outside drop.

QUESTION:—Explain what is meant by "outside drop."

ANSWER:—When a tooth of the escape wheel leaves the discharging corner of the exit pallet a free flight of the wheel is observed. This free motion is termed the outside drop and exists until another tooth is intersected by the opposite pallet.

QUESTION:—Explain what is meant by "inside drop."

ANSWER:—When a tooth of the escape wheel is discharged from the entering pallet a free motion of the escape wheel takes place. This free flight is termed the inside drop, and exists until another tooth is caught on the locking face of the opposite pallet.

QUESTION:—What does the term "shake" imply, as related to the pallet and teeth action.

ANSWER:—It has reference to that conjunction of the pallets with the teeth of the escape wheel where least freedom is found to exist between these parts.

QUESTION:—Do shake and drop express similar actions?

ANSWER:—No; they are totally different.

QUESTION:—As regards the pallets and teeth, how many kinds of shake exist?

ANSWER:—Two—inside and outside shake.

QUESTION:—Describe inside shake.

ANSWER:—Inside shake may be defined as that position of the pallets and of those teeth contained *between* the pallet jewels (Fig. 19), where least freedom is found to exist.

QUESTION:—How can we practically determine the existence of inside shake in an escapement?

ANSWER:—To observe inside shake, bring the tooth down to the lowest locking corner of the discharging pallet and note the space (T to A, Fig. 19) which exists; this separation represents the amount of inside shake.

QUESTION:—Describe outside shake.

ANSWER:—Outside shake is that position where we find least freedom between the pallet jewels and the teeth of the escape wheel just without the pallet jewels.

QUESTION:—Explain how to demonstrate practically the existence and extent of outside shake.

ANSWER:—To demonstrate outside shake bring the tooth locked on the receiving pallet down to the lowest locking corner as at S, Fig. 20; then observe the space separating K from L, Fig. 20; this space represents the outside shake.

QUESTION:—Should inside shake and outside shake be of equal extent?

ANSWER:—Yes; the shakes should be equal.

QUESTION:—Should the inside drop be equal in amount to the outside drop?

ANSWER:—Yes; the drops should be of equal extent.

QUESTION:—Suppose we have before us a watch in sound running order; at a time

the crescent state the position of the roller jewel.

ANSWER:—The roller jewel will have entered the lever notch.

QUESTION:—What is the position of the guard pin in relation to the crescent and of the roller jewel in relation to the lever notch, when unlocking takes place?

ANSWER:—The guard pin will be found within the crescent and the roller jewel will be found within the notch.

QUESTION:—When the guard pin is in the center of the crescent and the roller jewel at its greatest depth in the notch of the lever, give position of tooth and pallet.

ANSWER:—The impulse face of the tooth will be found on the impulse face of the pallet (Fig. 21).

QUESTION:—When is the guard pin found closest to the edge of the roller table?

ANSWER:—At the immediate moment it makes its exit out of the crescent.

QUESTION:—What phase of tooth and pallet action then takes place?

ANSWER:—The draw or second lock commences to take effect.



FIG. 21.

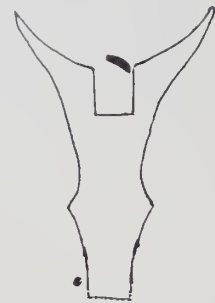

FIG. 22.

when we find the roller jewel beyond the tip of the lever horn we place a finger on the balance, holding it in this position. The tooth of the escape wheel is then locked on the receiving pallet, the lever at rest against its banking; describe the routine action of the escapement from the moment we release the balance.

ANSWER:—The roller jewel enters the notch of the lever, the guard pin enters the crescent. The roller jewel then strikes the lever notch a blow, which causes the unlocking of tooth and pallet; the tooth of the escape wheel then enters on to the impulse plane of the pallet; thereby the roller jewel receives a blow from the opposite side of the lever notch which causes the balance to travel with renewed energy. As the tooth of the escape wheel leaves the pallet's impulse face its free flight or drop is observed. Just as the tooth drops on to the opposite pallet the guard pin will be on the point of making its exit out of the crescent. After the tooth has dropped on to the opposite pallet a downward motion of the pallet jewel into the escape wheel will be seen. This is the secondary lock due to draw. The extent of this lock is controlled by the lever meeting the guard pin, and the guard pin is then at its greatest distance from the edge of the roller table.

QUESTION:—When we find the guard pin outside the crescent, state the position of the roller jewel.

ANSWER:—The roller jewel is outside the crescent.

QUESTION:—When the guard pin enters

QUESTION:—When is the guard pin at its greatest distance from the edge of the roller table?

ANSWER:—When the draw lock is completed the lever is then at rest against its banking.

QUESTION:—Name the three important positions of the guard pin.

ANSWER:—First, as it enters the crescent; second, at the moment of its exit out of the crescent; third, when the lever comes to rest against its banking.

QUESTION:—When the guard pin enters the crescent, give position of the roller jewel.

ANSWER:—The roller jewel enters the notch of the lever.

QUESTION:—Can unlocking take place when the roller jewel is in the lever notch.

ANSWER:—No.

QUESTION:—State from what source the roller jewel receives the blow which adds renewed vibratory force to the balance.

ANSWER:—From the side of the lever notch, which obtained its force from the mainspring transmitted through the tooth and pallet.

QUESTION:—As drop or first lock is completed state the position of the roller jewel.

ANSWER:—It will be found opposite the corner of the lever notch (Fig. 22).

QUESTION:—When is the roller jewel on its exit journey out of the notch closest to the corner of the notch?

ANSWER:—At the moment it commences to make its exit from the notch, *i.e.*, just before draw lock takes effect.

Keystone Solid Gold Watch Cases.



**Compact
Slender
Graceful
Symmetrical**

- ☐ 16 size, 12 size, 6 size, O Size, Jewel, Lady Elgin, 10 Ligne Waltham, Hunting and Open Face.
- ☐ Bascine, Plain Polish, Satin Finish and Roman.
- ☐ Juergensen, Engine Turned, Shield, Drop Shield and Spot.

**KEYSTONE 14 K. SOLID GOLD CASES ASSAY
585-THOUSANDTHS FINE**

(14 K. GOLD ASSAYS 583 $\frac{1}{4}$ -THOUSANDTHS FINE)

Look for

Trade-Mark



in Back.

Note this Guarantee



in Cap.



this Tag.

**The Keystone Watch Case Co.
Philadelphia**

**New York
Chicago
Cincinnati
San Francisco**

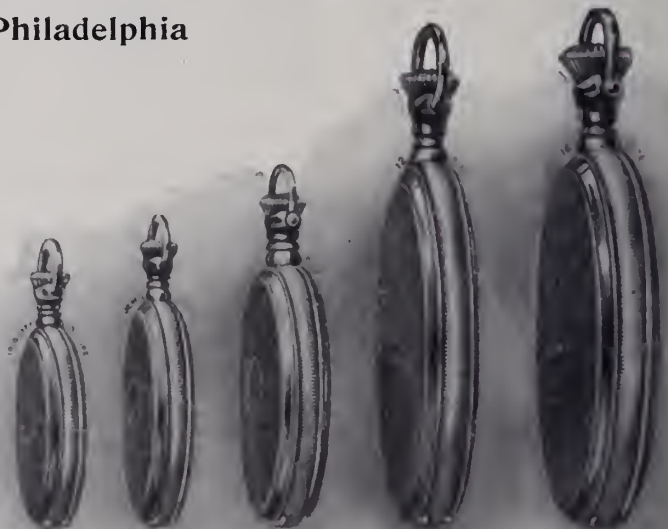

QUESTION:—What may be said of the relative positions of the guard pin to crescent, and of the roller jewel to the notch, the moment the roller jewel enters the crescent notch preparatory to striking an un-asking blow?

ANSWER:—We always find that when the guard pin enters the crescent the roller jewel is in the notch, as the question indicates.

QUESTION:—When the roller jewel starts to make its exit out of the notch (Fig. 22), where is the guard pin in relation to the crescent?

ANSWER:—The guard pin will be found still within the crescent.

(To be continued.)

Synchronization of Clocks by Gas Pressure.

B. BONNIKEN, in the *British Horological Journal*.

(See also issue of Jan. 29.)

MOUNTED on a suitable axle, such as the minute hand axle A of each clock like in the system, is a pinion which in this case represents the cannon pinion. The minute wheel B gears with the cannon pinion and is mounted on a shaft which carries two pinions, B² and B³ respectively. The pinion B² meshes with the 24-hour wheel C, and the pinion B³ meshes with the 12-hour wheel D. A snail is mounted on the wheel C. It is not fixed to the said wheel, but is adapted to be driven by the wheel by a suitable device, allowing of a limited independent relative rotation of the said wheel and snail, such as the pin C² in the wheel and slot C³ in the snail. The pinion B³ drives the hour wheel

On a suitable pivot such as E is mounted a lever, the one arm E¹ of which bears upon the periphery of the snail C¹, and is forced into contact therewith by a suitable spring. The other arm E² of the lever carries an armature E⁴ adapted to make and break contact with an electro-magnet F introduced into the electric circuit, which is supplied from any suitable generator X¹, preferably the local public electric supply. The arm E³ also carries a contact point E³ adapted to contact with two mutually insulated blades E⁵ and E⁶ to complete the first half of said electric circuit. A projection E⁷ on the arm E³ of the lever is adapted to operate in the path of a circular series of studs G mounted on a rotatable plate G¹; and the amplitude of the movement of this projection E⁷ is equal to the distance between each stud G and its neighbor.

The studs are adapted to pass one at a time through a contracting radial guide H on a disc H¹ fixed to the axle A. The other half of the circuit is adapted to be closed by the action of a lever, the arm J of which carries a pin J¹ which bears upon the periphery of a cam A², which also is fixed to the axle A. The said cam has two shoulders A³ and A⁴ arranged at suitable parts of its periphery, and connected by a concentric portion. A collar C⁴ provided with a notch C⁵ is fixed to the 24-hour wheel C. The arm J² carries a pin J², which normally holds the spring blade in contact K clear of contact with the spring blade contact K¹, these two blades also being introduced into the electric circuit. The

spring blade K, bearing upon the pin J², causes the pin J¹ to bear upon the peripheries of the collar C⁴ and cam A².

The electric current for all the clocks in the system is passed through a single main switch, preferably at the generating station, which may be that of the local electric lighting authority. The switch may be adapted to be opened at any one moment by a weight or spring released by any suitable means by a standard clock mechanism. The weight or spring-driven body is adapted to strike upon a lever or other mechanism normally held up and returned to the "closed" position by a spring or balance weight.

The action is as follows:—The pinion A¹ rotates the wheel C through the minute wheel B and its pinion B² once in 24 hours. The snail C¹ is carried round by the wheel in approximately the same time. As the snail rotates the lever E¹, E² is moved so as to gradually bring the armature E⁴ nearer to the magnet F, and to close the first switch E⁵, E⁶. At, say, two minutes before the completion of the 24 hours the pin J¹ falls over the shoulder A³ on the cam A², and moves into the notch C⁵ in the collar C⁴; the pin J² moves at the same time, allowing the blade K to come into contact with the blade K¹, and thus completing the second half of the circuit. The completion of the entire circuit excites the electro-magnet F, which attracts the armature E⁴ and holds the lever E¹, E², until the circuit is broken.

The movement of the armature E⁴ lifts the arm E¹ of the lever clear of the snail C¹, and the snail, being thus freed from the braking effect of the lever, is carried round by a light spring L far enough for the shoulder of the snail to clear the said arm E¹ upon the lever being released, and allowing it to fall back into contact with the periphery of the said snail at its smallest radius. The concentric portion of the double cam A² rotates under the pin J¹ during, say, a period of ten minutes.

At the moment of synchronization the standard clock releases the weight or spring actuating the lever or other mechanism and opens the main switch, thus breaking or otherwise reducing the current of the circuit. The main switch immediately returns to its normal position, and the weight or spring can be again set ready for action by any suitable means, automatically or otherwise, before the next moment of synchronization. The breaking of the circuit releases the levers E¹, E² in all the clocks in the system, the said levers falling back to their normal position. As each lever is thus moved the projection E⁷ operates on the stud wheel G¹, and moves it round to the extent of one stud; and as the stud wheel is thus moved one of the studs thereon is forced through the contracting radial guide H on the disc H¹, the narrow end of which is made a good working fit for the studs G.

The disc H¹, the axle A, and hence the minute hand A³ fixed to the said axle are thus brought to a precise angular position corresponding to the correct time as communicated by the standard clock, which is preferably regulated by the standard time of the country. The circuit having been broken, the pin J¹ after a time falls over the shoulder A⁴ of the cam A². The pin J²

moves at the same time so as to allow the end of the blade K to pass under the bow K² on the blade K¹. As the cam A² further rotates it gradually lifts the pin J¹ and moves back the pin J² and blade K. Any contact made between the blades K and K¹ during this return movement will be of no effect, as the switch E⁵, E⁶, E⁷ is broken during this period. One synchronization cycle having been concluded, the parts are left to prepare themselves during 24 hours for the next.

The above synchronizing mechanism, Mr. Chandler and myself are responsible for originating, and we believe it is quite original in many of its details. The fact that the German Patent Office accepted it, and granted us a patent, helps to confirm this belief. The first, or model, clock was now made by myself, and a gross of sets of component parts of clocks were made for us by one of our leading English clock manufacturers, and by the help of these parts, the fitting up of a number of clocks was now carried out in the Synchronized Electric Clock Co's workshops under Mr. Chandler's superintendence. To give the readers an idea of the working of the system, and yet escape the, to me, distasteful necessity of praising my own work, I here give reprints from the *Leamington Chronicle* of March 18, 1905, which all speak well for the clock system under consideration at that time the clocks were driven and synchronized solely through the electric cables:

"Those 'small servants of Time,' as Stevenson called them, which we keep in our houses to note the flight of the hours are, like most servants, occasionally given to carelessness and inaccuracy, and require careful watching to keep them in order. It is not the least worrying of life's little worries to find that no two clocks in your house agree, and that the one on which you had depended to warn you when the time had come for you to leave to catch a train has been silently falling behind Father Time day after day, with the result that you have the pleasure of seeing your train glide away from the platform without you. To the work of devising some means of preventing such small annoyances—and no one knows when circumstances may make what is normally a small annoyance a serious misfortune—many inventors have from time to time given much thought and attention.

"Their labors have not been without result, and several systems for 'synchronizing' clocks and timepieces, *i.e.*, automatically insuring that they shall always keep correct time within a fraction of a second, have been brought under the notice of the public. In one system, which is at work in Paris, the object sought after is attained by means of compressed air; in another, electricity; the handy man among natural forces, is pressed into the service. The principal bar to the general introduction of these systems is their expense. Only in the very largest communities could they be introduced with any hope of commercial success, and under any circumstances they would always be somewhat of a luxury.

(To be continued.)

O. D. Gunn, Biloxi, Miss., is about to discontinue his jewelry business.

? ?

? HAVE YOU SEEN THEM ?

? ?

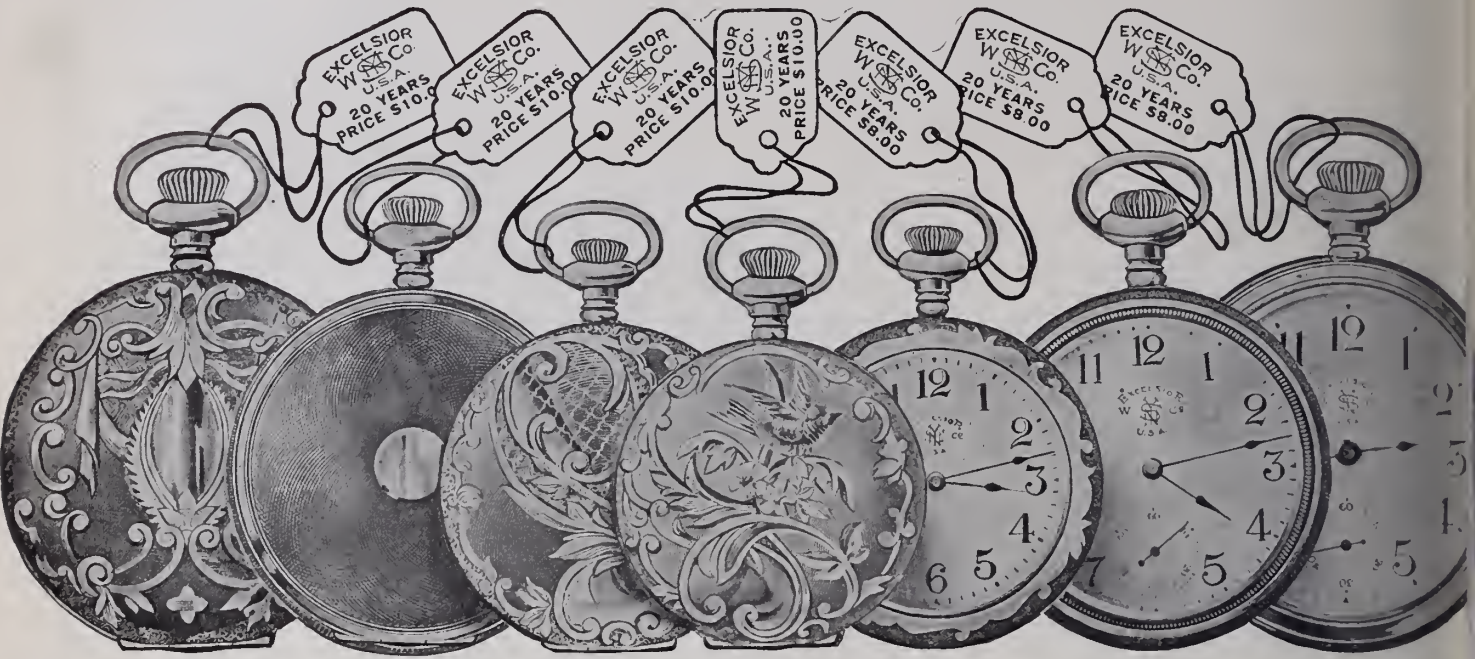

If not, ask your Jobber for the new line of

Excelsior Watches

Made Especially for the Jeweler

In 6, 12, 16 and 18 Size Open-Face and Hunting

Furnished as Complete Watches only in {

- 20-year Gold Filled
- 10-year Gold Filled
- Silverode

Factory Tag Showing Price on Each Watch

GOOD PROFITS IN THEM FOR YOU

Three quarter Plate, Nickel Damaskeened, Nicely Finished Throughout, Specially Timed, 7 Jewels, Quick Train with Bearings in Metal Settings, Cut Expansion Balance, Breguet Hairspring, White Enamel Dial.
 Every Watch is STEM WIND and PENDANT SET (excepting the 18 Size Hunting, which is LEVER SET)

All are THIN MODELS
 All are "Timed in Case" at the factory
 All sell at "Fixed" prices Everywhere

If you have mislaid your Trade Booklet, write for another copy NOW

NEW YORK STANDARD WATCH CO.
JERSEY CITY, N. J.

New England

WATCHES

stand alone as the only high-grade watches made that sell at a medium price. Dealers who do not carry them will lose more sales this year than usual, for the demand will be even greater than before.

New England Watches are equal in workmanship and appearance to the most expensive watches manufactured, and being sold at a medium price they have been aptly described as

"The Watch for the Great American People"

The "Great American People" are demanding a high-grade time-piece for a moderate price. The best preparation you can make to supply this demand is to put in a full line of *New England* Watches at once. Bear in mind that every watch is fully guaranteed by the manufacturers.

THE NEW ENGLAND WATCH CO.

Waterbury, Conn.

Chicago

San Francisco



The above TRADE MARK is well known to you, because it is on every watch and watch movement made by the LANGENDORF WATCH CO.

The more of our large line you carry in stock, the more profitable and satisfactory are

YOUR SALES

Perfect Interchangeability of parts renders repairing easy.

Do not accept substitutes, but insist upon getting the genuine L. W. Co. make. It's far the cheapest after all, as the quality is such you may

DEPEND UPON

If your jobber cannot supply you with

THE RIGHT KIND of GOODS

write to the Sole Agents for the United States,

AMERICAN-SWISS WATCH CO.

1 Maiden Lane, New York
CUSHMAN BUILDING

HALL CLOCKS



Elliott's
Celebrated
Tubular
Chimes

HARRIS &
HARRINGTON,
12 BARCLAY ST.,
NEW YORK

Sole Agents to the Trade
for
J. J. ELLIOTT & CO.
LONDON.



THE  OIL

NEVER
GOES
WRONG

The trade from ocean to ocean is praising this wonderful oil. IT POSITIVELY WILL NOT GUM.

Can you say as much for the oil you are using? Send 25c. to your jobber for a bottle, and end your oil troubles.

RANLETT & LOWELL CO.

SOLE MANUFACTURERS
Jewelers' Building BOSTON, MASS.

Wholesale Selling Agents
M. SICKLES & SONS . . . Philadelphia
SWARTCHILD & CO. . . Chicago
NORDMAN BROTHERS CO., . . San Francisco
D. C. PERCIVAL & CO. . . Boston
CHAS. MAY & SON . . . Boston
DANIEL PRATT'S SON . . . 53 Franklin Street, Boston
SUSSFELD, LORSCH & CO., . . New York City
H. S. MEISKEY CO. . . Lancaster, Pa.

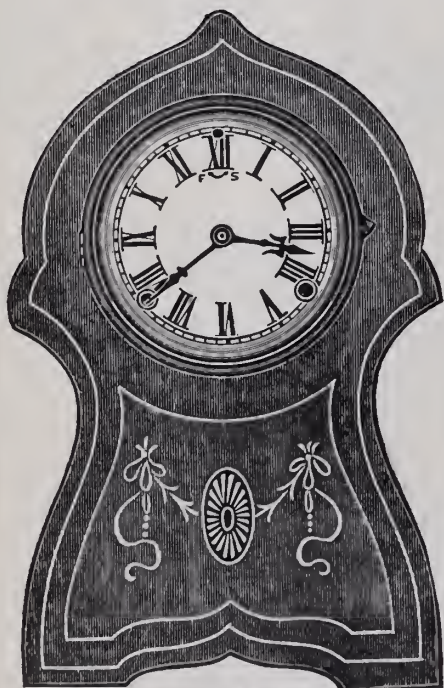

MANCHESTER
Height 13 3/4 in. Width 8 3/4 in.

SESSIONS CLOCKS

Superior Finish
Popular Prices

We have added a number of fine marqueterie cabinet clocks to our line which will interest you.

The Sessions Clock Company

FORESTVILLE, CONN., U. S. A.

New York Salesroom, 37 Maiden Lane

JULES JÜRGENSEN
Watches and Chronometers

PARIS—"THE GRAND PRIX"—1900

SOLE
RUDOLPH & SNEDEKER
65 Nassau St., New York
AGENTS

New England Watch Repairing for the Trade

GEO. W. HYDE & CO.
101 TREMONT STREET
BOSTON, MASSACHUSETTS

Make a Specialty of Repairing
New England Watches
Work returned in one week, and guaranteed to be satisfactory in every respect. Recommended by The New England Watch Co.

Ball Watches
THE RAILROAD STANDARD

Mr. Retailer!

*Every Time You
Sell a "Ball" Watch.*



1. You earn a fair return on your time and capital invested.
2. You secure a satisfied customer (the best advertisement of all).
3. A machine goes into service which will add to your reputation as a reliable "watch man."

Write to-day **THE WEBB C. BALL WATCH CO.**

Ball Building, CLEVELAND Railway Exchange, CHICAGO

Buy Watches With Our Patent Ball-Bearing Bow

Already on the Market

No watch case should be without it.

BEWARE OF IMITATION



Should your jobber not sell cases with these bows, write us and we will give you a list of jobbers who do.
Patented July 25, 1905; May 21, 1907. Other patents applied for.
Patented in foreign countries.

The Wachter Manufacturing Co.
HARTFORD, CONNECTICUT

ESTABLISHED 1887

DUBOIS WATCH CASE CO.

Manufacturers of

Fine Solid Gold Watch Cases

Specialties in Casing of

CHRONOGRAPHS, REPEATERS AND ALL KINDS OF COMPLICATED WATCHES

NEW YORK OFFICE:
21-23 Maiden Lane

FACTORY AND MAIN OFFICE:
316 Herkimer St., Brooklyn, N. Y.



18 K



14 K



THE progressive jeweler to-day knows that when a customer comes into his store he must be impressed with the idea that he is doing a high-class business.

In order to do this he must have the goods. No article you can buy will give your store more tone than a fine Hall Clock. It will also give you a fine profit. Purchase a "Waltham" and you will soon find a customer for it.

Send for catalogue, descriptive of many styles and kinds.

WALTHAM CLOCK COMPANY

Office and Salesrooms, Waltham, Mass.

Trade-Mark.



Trade-Mark.

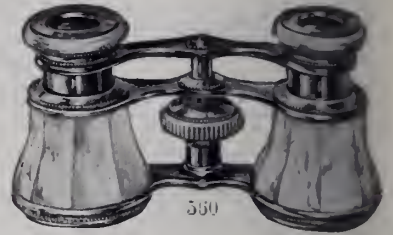
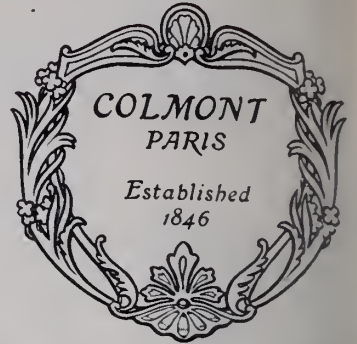

COLMONT OPERA and FIELD GLASSES

have been recognized by Opticians who really wanted a good article without paying too high a price.

With Colmont Glasses
You Have a Guarantee

The name STANDS for honesty and uniformity of construction, fairness of price.

For your own advantage, investigate the "COLMONT" line at your jobber's.

**SUSSFELD, LORSCH
& CO.**

Importers
NEW YORK PARIS

A.W.C.CO

Moderate-priced Cases



14K.
C-1992

The illustration represents one of a large line of gold cases designed to sell at prices in accord with the expectations of the average purchaser. It isn't cheap, neither is it expensive; but nicely adjusted to the circumstances of the every-day buyer. The price and quality are rather disproportionate. We invite comparison to emphasize the superiority of these cases.

Sold by us directly to you

American Watch Case Co.

9-11-13 Maiden Lane

New York

The Lady Racine

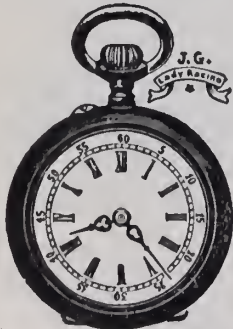

JULES RACINE & CO.,
103 STATE ST., CHICAGO. SOLE AGENTS 37 MAIDEN LANE NEW YORK.

For Sale by all Jobbers

Positively the BEST chatelaine watch in the market.

Machine Made

10, 11, 12 and 13 Line; Cylinders and Levers; cased in Nickel, Gun Metal, Silver and Gold.

Material on Hand.

Write for prices.



Lady Racine
Nurse Watch.

REMOVAL

FROM

PHILADELPHIA to NEW YORK

No. 35 MAIDEN LANE

Wm. C. Penfold Co.

Largest Exclusive Watch Jobbers in New York

OF

Dueber-Hampden Watches Dueber Cases—Hampden Movements

A COMPLETE LINE ALWAYS ON HAND

Mail Us Your Orders



THE ROCKFORD WATCH
For ALL CLASSES

"True Time for a Life Time."

Rockford Watches

The Most Profitable and Satisfactory
Watch for the Legitimate Jeweler.

WRITE TO-DAY FOR PRICE LIST AND ADVERTISING MATTER

ROCKFORD WATCH COMPANY, ROCKFORD, ILL.

STORE KEEPING DEPARTMENT

That this department shall prove mutually beneficial to our readers, it is desirable that the members of the trade generally communicate with THE JEWELERS' CIRCULAR-WEEKLY regarding any advantageous device or plan which they are utilizing in connection with their business.



Mechanical Window Displays

Constructed With a View to Enhancing the Attractiveness of the Jeweler's Show Window

By Otto Jonas

The Swinging Bell.

A ROLL of ticker tape and two five-cent bottles of mucilage are all the materials required for this display outside of those which can be picked up around any retail store. Get two pieces of stiff cardboard (the kind used by the writer in

unloosen a little more and repeat the process until the entire roll becomes sufficiently loosened to be worked with.

Place the roll of tape on top of your frame so that the hole in the center of the roll fits over the point at the top of the frame. Now very firmly and slowly press

take a day or two. When thoroughly dry turn the bell up, removing the frame. Repeat the mucilage-spreading formula on the inside and let the bell dry again. When thoroughly dry you will have a light, well-shaped frame.

Tinfoil should cover the entire outside of the object and should be used on the inside, working it up three or four inches from the bottom. Smooth out the tinfoil first. Paste it on neatly and the result will imitate a heavy silver bell.

Whittle a piece of wood into the required shape, covering this also with tinfoil, and you have a clapper for your bell. Attach a string to the clapper, tie a knot about 10 inches above this clapper, run the string through and suspend your bell. The window can then be arranged as shown in Fig. 5.

The fan should, of course, be concealed. The ground plan of the window is illus-

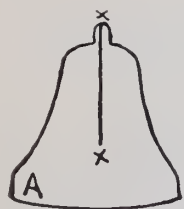

Fig. 1.

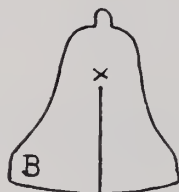

Fig. 2.

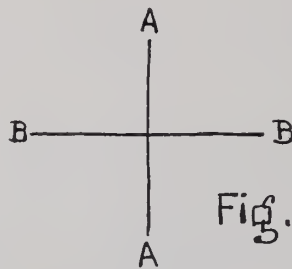

Fig. 3.

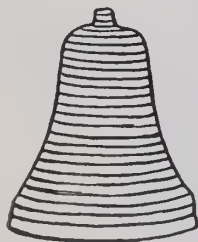

Fig. 4.

HEAVY CURTAIN

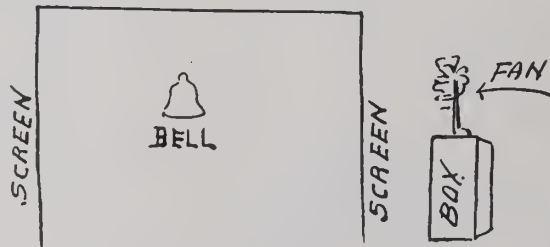

Fig. 6.

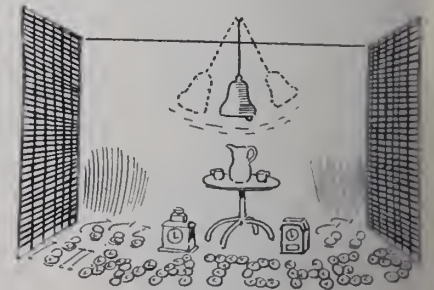

FIG. 5.

working out this scheme was 8 by 12 inches). Cut the cardboard into patterns as shown by Figs. 1 and 2. The line from x to x on each design represents straight slits. Excepting this feature, the patterns are identical.

Slip these two parts together so that they cross at right angles. Fig. 3 shows clearly the manner in which this is to be done. This is a cross-sectional view. Then you have your skeleton framework ready.

Take your roll of ticker tape; start from the center and be careful not to tear the outer rim of the tape that encircles or protects this outer edge (as it is very important that this be left intact). Draw out about five yards of the tape in order to loosen it up. If it does not work easily

down the ticker tape, beginning at the center and working it over, moulding it to the frame. This part of the work can be more accurately done if managed by two persons, and this part of the construction must not be hurried if a neat, uniform result is desired. When completed each end of the tape should be just halfway overlapping the next layer, and should look like Fig. 4.

Pass your mucilage brush freely over the outer edges. After the surface is fairly sticky you may soak the whole outside surface liberally with mucilage, being careful to spread it evenly. Paste will not answer the purpose of mucilage. After the work has been thus far completed let the whole affair stand until thoroughly dry. This may

trated in Fig. 6. If lattices are arranged like Fig. 5 spaces should be left between them so that air blowing from the fan through the spaces will cause the fan to move slowly backward and forward.

It will require patience and ingenuity to get the fan properly adjusted to your particular window, so that sufficient force will be directed against the bell. All other fixtures in the window ought to be firmly adjusted so that nothing except the bell will move. To the uninitiated passerby this apparently heavy bell moving without visible aid forms a mystifying attraction.

The latticework screens can be constructed quickly and economically by using ordinary lathe. Cover these with paper pasted on or painted. Place the electric fan where it will be out of sight from both street and store. It will be easy to hide the fan without using screens. Stock such as large-sized clocks or silverware can be so placed that the fan will be concealed, and will yet permit a breeze to strike the bell.

Storekeeping Department.

The Newly Furnished Store of Frank Ricard, Lowell, Mass.

ILLUSTRATED herewith are two views of the attractively furnished new store of Frank Ricard, Lowell, Mass., who started in business in February, 1894, with floor space of six by 10 feet and a very minute window display. At that time the store was located at 660 Merrimack St. Repairing of all kinds was made a specialty. The stock was moved into a larger store at 640 Merrimack St. in 1896, and here Mr. Ricard remained until last Summer, when the store at 636-638 Merrimack St. was leased and extensive alterations made in the premises. New fixtures, wall and show cases and mirrors were installed.

The concern now has a floor space of about 2,700 square feet, the dimensions of the store being 30 by 90 feet. There are five wall cases, each 14 feet long, with a level edge, and between each case is a plate glass mirror, 36 by 72 inches. As one enters the store there are seen on the right three cases, and on the left two cases. A feature of the business has always been the watch repairing department, where there is a watch rack space 14 feet long and having the capacity to contain 200 watches. There are also three watch benches.

Besides the above mentioned cases there are upright cases and one umbrella case, the latter allowing the rainy day requisites to be exhibited in a conspicuous and attractive manner. The establishment has three safes, one of which is lined with steel.

The circular seat, seen in the central part

of the photograph in the interior of the store, is upholstered in green plush, the upper portion of the post around which it is built being adorned with plate glass mirrors. The store is carpeted with inlaid German Rixdorfer linoleum.

Another attractive feature of this store is the ceiling, which is divided into panels with an 18-inch frieze which has been hand-painted by a Belgian artist.

The heating facilities of the store are all that can be desired, the store being kept warm and comfortable in the Winter time

A Display for St. Patrick's Day.

A WINDOW in green is here pictured for a typical St. Patrick's day display. The symbol of Ireland is used as a central feature, while jewelry in boxes forms a graceful curve in front. The boxes should be of green cloth or paper.

In front of these, at either side, encircled

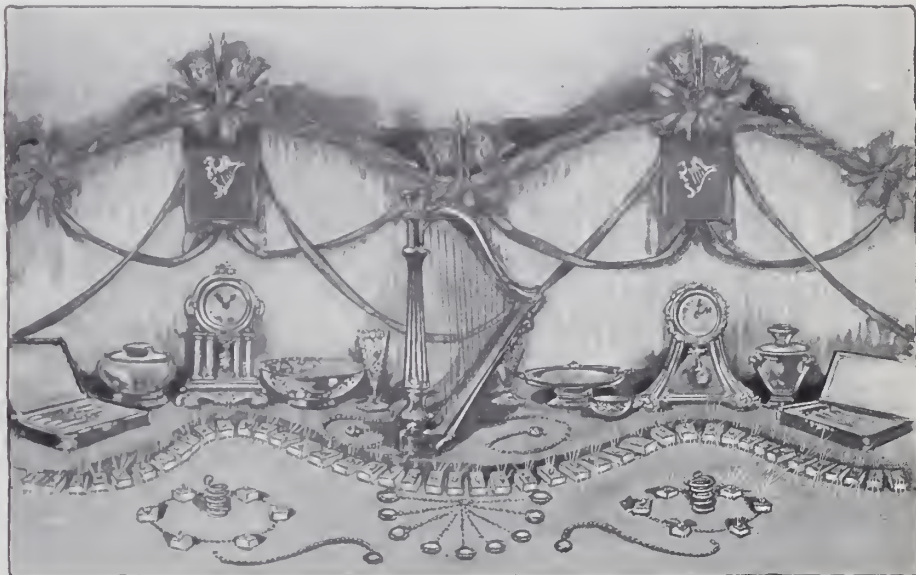

ORIGINAL WINDOW DISPLAY, SHOWING JEWELRY AND EMBLEMS OF ST. PATRICK'S DAY.

by means of a hot-air furnace. A separate room in the basement is devoted to the clock repairing department.

This store is well systematized and contains several well arranged departments, in-

cluding separate departments for silverware, clocks and optical goods, religious articles, glass ware and cut glass, china and other stock.

by jewelry or watch chains, is a gold snake bracelet, a very popular trinket just now and particularly appropriate for this display. The two large twisted loops connecting the groups of Irish flags can be green crepe paper or cloth fabric of some sort. Bands of green ribbon hang in a festoon arrangement, as shown in the illustration.

The Way of the Enterprising.

A PLEASING window display shown recently by Chas. F. Rudolph, Wilmington, Del., consisted of two dainty groups of carnations which won prizes at the recent convention of the American Carnation Society in Washington.

E. D. Howard Ware, Mass., recently displayed in his show window a copy of the *Ulster County Gazette*, published at Kingston, N. Y., Feb. 4, 1800. The paper is discolored by age and has been framed in order to preserve it. It is owned by Mrs. Nelson Williams, of that place.

J. Lott Losey, South Bend, Ind., has sold his stock to his father, John R. Losey, who has removed it to Plymouth, Ind., where he has consolidated it with his own stock. J. L. Losey will in future devote his entire attention to a new jewelry enterprise which he has started.

Adam Judson, jewelry peddler, was found lying in the snow a short time ago near Ralston, Pa., in a dazed condition. His rifled jewelry box, from which a large amount of rings and watches had been stolen, was found nearby. Two men have been arrested on the charge of having committed the crime.



INTERIOR VIEW OF THE STORE OF FRANK RICARD, LOWELL, MASS.

cluding separate departments for silverware, clocks and optical goods, religious articles, glass ware and cut glass, china and other stock.

RETAIL JEWELERS ADVERTISING

The use of this department is open to every retail jeweler. Forward for criticism your newspaper ads., booklets, catalogues, novelties, circulars, etc. Ask advice and offer suggestions. Replies in these columns are unbiased. Make letters as full and particular as you desire. Every letter and ad. sent will receive full attention, though the publication of the matter may sometimes be delayed several weeks.

AMONG the miscellaneous advertisements illustrated below will be found several which will offer suggestions to those who wish to prepare copy for the advertising of wedding gifts, invitations, etc.

The C. A. Tucker announcement, reduced from 13 inches, double column, has a most timely illustration and a catch phrase as

Another jeweler who believes in fighting the mail order concern on its own ground is John N. Mulford, Memphis, Tenn., whose advertisement of six and one-half inches, double column, should at least prompt a goodly number to write for the jeweler's catalogue. If the ad. has accomplished this its main purpose has been fulfilled.

tionery, etc. The offer has been neatly advertised in the accompanying announcement, reduced from four and one-half inches, triple column.

The Harris-Goar Co., Kansas City, Mo., advertised a special diamond sale in an original manner. The letter "D," suggesting diamonds, forms a border for the text.

Up in the center of the group is a diminutive announcement by J. F. Boes, Salt Lake City, Utah, who adopts a "triple-power" method of impressing his name upon the reader. There is the name itself, an Indian bow and the bows of ribbon tied at either end. The original ad. occupied a space of only two inches, single column.

Above this is a space of four and three-quarter inches, double column, which the B. H. Stief Jewelry Co., Nashville, Tenn., says it "has cheerfully given for a cause dear to all and for the perpetuation of the precious memories of heroism and devotion of the glorious women of the Confederacy." This is generosity, indeed, but the inevit-



Happy Brides and Wedding Bells

The month of love and romance is near at hand—the time when shy-eyed women to suit his desire more accurately than at any other season of the year. Engagements, weddings and rumors of weddings will be the order of the times—and associated with each occasion comes the thought of romance. What shall we give the happy couple? It is also the pressing question of the hour—last have wants rivaled by a tip to Tucker's headquarters for wedding gifts. While you are planning ring want for the maid a one of a few gifts that would please her.

BEAUTIFUL DESIGNS IN SOLID SILVER.
It comes, lasting and appropriate—a gift that would be appreciated for time and lasting friendship. That's your choice—here's another.

Beautiful China
Get your beautiful designs, a host of new and pretty things that make good sensible and useful wedding gifts—and last but not least—

Wedding Jewelry
A diamond set in anything brooch, ring, pendant, we want you what no amount of money can buy in jewelry to equal ours and the designs are new, talk for their reasonable price.

From shell, bracelets, rings, watches, Ebla want, brooches, signet rings, neck chains. Non-aluminum of jewelry, beautiful creations of the Jeweler's skill and genius. Too many kinds and varieties to enumerate but a stock that is sufficiently large in almost of wide selection.

We would be glad to have you come in and see what we have at our stock house and give us suggestions and get acquainted with the big gift store.

C. A. Tucker Jeweler
1123 O Street
A-26

BRODNAX

Buy Invitations Bearing the Imprint of a Successful Firm It Costs No More

When you go to making an invitation you, of course, want to make as cheaply that they are accepted properly, that they will hold at once, but have used, and that the form of the invitation is correct.

There are many ways to avoid the expense of having the type set who want to avoid the expense of having the type set who want to avoid the expense of having the type set.

If your invitation bear the imprint of the B. H. Stief, for our signature for doing things properly in this respect, you will probably save as much as twenty to thirty per cent. from the cost of a regular invitation. We have a large stock of our own designs and by having them set in gold or silver, you can get a very elegant invitation for a very small price.

So you can order invitations from us with the certainty of getting the best that can be produced, and at a saving of fifty per cent. will also understand that they are the best.

As an example of the low prices we are able to give you with our line of engraved in English, steel, brass and silver, we give you the following:

100 different invitations will bring you only \$1.00.

A reference for further information will bring you only \$1.00.

Wholesale orders of wedding invitations will be given the same price, and the proper cards will give you the same price. We will be glad to answer any questions you may have.

Geo. T. Brodnax, Inc.
Gold and Silver Smiths
Memphis, Tenn.
22 South Main St.

This space is liberally given for a space due to all and for the perpetuation of the precious memories of heroism and devotion of the glorious women of the Confederacy.



The B. H. Stief Jewelry Co.
404 Union Street
NASHVILLE, TENNESSEE

If It's Made of Gold, We Make It



J. E. BOES
JEWELER
SALT LAKE CITY, UTAH

ANOTHER WATCH TALK.

If you find yourself in a predicament where you need a watch that you can depend on, and that will last for years, you should get a watch from A. C. Smith. We have a large stock of watches, and we are able to give you the best that can be produced, and at a saving of fifty per cent. will also understand that they are the best.

A. C. SMITH, Grand Watch Importer
Approved by the U. S. Government
117 Broadway, New York City

Wedding Gifts of Quality



The approval of Fall brings new and beautiful designs in Sterling Silver and Cut Glass. Our designs are all made in our own shops and are of the best quality. We have a large stock of our own designs, and we are able to give you the best that can be produced, and at a saving of fifty per cent. will also understand that they are the best.

C. H. Leonard,
The Reliable Jeweler
436 Main Street, West, Conn.
Both Yelms.

To-Day's Your Day

It is the day of the diamond sale.

Diamond Sale
The sale and purchase of diamonds, jewelry, and other precious stones.

\$24.50

Harris-Goar's
1897 Grand Ave.

Fair Visitors

MAKE YOUR HEADQUARTERS HERE. Use Our Telephone, Cigar and Writing Rooms

Package Delivered to the Depot Free of Charge

Thorpe & Hoberg
312 NORTH SIoux CITY'S LEADING JEWELERS BOTH FORMS

Gifts

A Bride

to give you a happy wedding, we have a large stock of wedding gifts, and we are able to give you the best that can be produced, and at a saving of fifty per cent. will also understand that they are the best.

W. K. Cowan & Company
215-217 Main Street
The First Floor Building

Your Mail Orders

Receive Our Immediate and Most careful Attention

Write for MULFORD'S Catalogue. It is a book of 100 pages, and it is the best that can be produced, and at a saving of fifty per cent. will also understand that they are the best.

MULFORD JEWELER
MEMPHIS, TENN.
6 SOUTH MAIN ST.

WEDDING GIFT AND OTHER SINGLE AND DOUBLE COLUMN ANNOUNCEMENTS USED BY RETAIL JEWELERS.

"winsome" as the dainty bride appears to be.

The man who wrote the advertisement of Geo. T. Brodnax, Memphis, Tenn., knows how to appeal effectively to prospective buyers of wedding stationery and announcements. The last paragraph forms a strong conclusion to a generally well-written advertisement.

A. C. Smith, Mexico City, Mex., gives the public a convincing line of watch talk in an advertisement which has been reduced from 10 inches, double column. Watch owners and those who intend to purchase pocket timepieces are made to feel that Mr. Smith knows watches as a competent watchmaker should know them and that his words of recommendation may be depended upon.

Chinese jade jewelry is well advertised by S. Nordlinger & Sons, Los Angeles, Cal., in a space of four inches, single column. The Oriental character of the jewelry is well brought out by the characteristic illustration.

W. K. Cowan & Co., Chicago, have an advertisement which is very attractive typographically. The ring illustrated is hardly one to advertise as suitable for a bride. The illustration could in fact have been omitted entirely without detracting in any way from the general merit of the advertisement.

During a fair held at Sioux City, Ia., Thorpe & Hoberg, enterprising jewelers of that place, generously invited visitors to make their headquarters at their establishment and use their writing rooms, sta-

able wag will say that it is also "dam good advertising."

The ad. of C. H. Leonard, Westport, Conn., originally occupied five inches, double column. Prices should have been quoted in an announcement of this kind.

The engagement has been announced of Miss E. Rumsey, of St. Louis, Mo., and Pierce Carter, of Paris, France. The ceremony, it is said, will take place at Miss Rumsey's home shortly after Easter.

The J. J. Sweeney Jewelry Co., Houston, Tex., will soon move from the corner of Main and Congress Sts., where it has been located for a long time, to the Burns building, corner of Main St. and Prairie Ave. The new quarters have been entirely fitted up in attractive style for the jewelers.

Retail Advertising Department.

The Jeweler's Appeal to the Farmer.

Written expressly for THE JEWELERS' CIRCULAR—WEEKLY by FRANK FARRINGTON.)

In most parts of the country the farmers' trade is of much importance. In the smaller towns the prosperity of the town often depends upon the financial condition of the farmers in the surrounding territory and at the present time if there is one class of people who have continued to be prosperous in the face of adverse conditions, that class is assuredly the farming class.

In view of the fact that the farmers today have more money to spend than any other class, it is certainly desirable for the jewelry trade to take particular pains to interest them.

The farmers are better business people than they ever were before. They are nowadays an educated class and know what they want and are willing to pay a fair price for it.

The fact that they buy so largely from the mail order houses is not so much due to any peculiarity of the farmer as it is due to the everlasting persistence of the mail order advertisers and the everlasting failure of the retailers to appreciate that if they were to go after the business in the same way as the houses a thousand miles away do, they would leave those long distance shop-keepers scarcely a leg to stand upon.

The farmer is perhaps naturally a little suspicious. He requires first of all to be assured that what he is to buy will prove to be the quality he thinks it is and what it is represented to be. On this account the local dealer in a line of jeweler's goods has every advantage over a mail order house. He can show the man the goods himself and he is right on the ground where he can be required to make good in case of any failure on the part of the articles he sells to come up to advertised standard.

A jeweler from the nature of his stock and the high prices of his goods, needs first of all to be responsible. He must have the confidence of his customers and the first step in going after the trade of the farmers should be to gain their confidence. Once they are assured of your reliability and that they can depend upon your goods to be just as you represent them they will be willing to do business with you. The next thing is to show them what you sell and make them want it and that is nothing but the straightest kind of advertising.

The direct by mail method is a good way to get at the farmers for they give careful attention to everything they get through the mails. They are not overburdened with circular matter in the way that a town business man is. All their mail is read.

This does not mean, however, that you can send the farmer any kind of printed matter which you want to, the cheaper the better, and get results. The recipient of cheap grade advertising matter, if intelligent enough to be a possible customer, will be intelligent enough to judge your store by the quality of its advertising.

The mere fact that much of the advertising matter that the farmer does get is cheap in appearance makes it all the more desirable that yours be of fairly high quality. It will get results greater in proportion to its attractiveness than when sent to other classes of buyers.

It is important that the farming trade be made to feel at home in your store if you would have them buy there. They are often rather diffident buyers. They do not like to shop around but prefer to go to a place where they know that they will be treated right and buy what they want right there.

Proper treatment when buying means to them being treated with due courtesy and not with the superior air that many salespeople have with the customer who cannot put up a bluff that he knows about the goods he is buying. The farmer depends upon the salesman's honesty more than the villager. He knows that he doesn't know much about the goods and he knows that the salesman knows that he doesn't. Also he hates to expose his ignorance too much or ask too many questions. He has pride the same as anyone.

The salesman who will get on best with the farmer is one who is honest, accommodating and friendly. The supercilious one will make the farming trade look elsewhere.

Well-to-do farmers want good value for their money. If they feel that the article costing \$10 is worth more than the difference in price, they will be pretty apt to buy in place of the \$5.00 article.

They care rather more for durability and stability than for beauty and are more apt to buy with a view to permanence than is the society person.

Show the farmer the watch that will give him accurate time and last the rest of his life and that is the watch he wants. Of course, it must be good to look at, but he does not want style. Style as you view it is not a thing that he is posted upon.

The personal element is strong with the farmers. They like to be able to walk into a store and call someone by name. They like to do business with a man they have done business with before. Urge your clerks to learn and to remember the names of their farmer customers. It will pay better than the same effort in connection with town trade.

When a farmer comes in who is known to one of the clerks, it should be arranged if possible to have that clerk serve him. If that particular one cannot do so, let him make it a personal matter to take just a moment to introduce the farmer personally to another salesman with the assurance that "Here is a man who knows just as much about these goods as I do and you can depend on him to treat you right."

The farmers will give a store that they like more word-of-mouth advertising than other people. Farmers are clannish and if they like the store, they will go out of their way to recommend it to their friends and their friends will take their word.

The farmers' wives and children ought to be treated well and it is a mistake to think that they do not appreciate little courtesies as much as others. They appreciate them more for they see less of them.

(To be continued.)

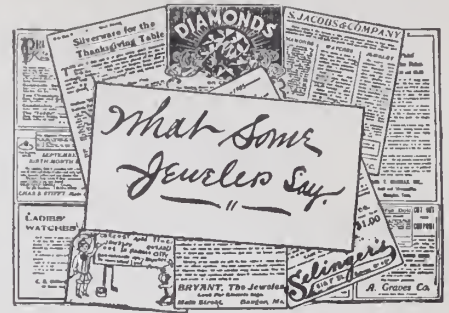

Catch phrases, descriptions and arguments which retail jewelers have used in their newspaper advertisements.

ADVANCE showing of the newest patterns for Spring and Summer of combs, bracelets and belt buckles. 18k. solid gold inlaid back combs, \$3.50 upwards; bracelets in all sizes and finishes, either plain or engraved, from \$1 to \$25; belt buckles—the newest patterns for Spring, engraved or jeweled mounted—\$1 and upwards. Clifford D. Cassel, Norristown, Pa.

Spring jewelry in newest designs—Roman pearl necklaces, beautiful for Summer wear; belt and sash buckles; bracelets in all styles and prices; hat pins, entirely new; feather lace pins. C. D. Silverthorn, Lynchburg, Va.

Graduation Gifts—You will soon be looking for wedding as well as graduating gifts. Arrange to meet this occasion by a visit to our store, where you will be cheerfully shown through the stock. Don't feel obliged to buy. We consider courteous treatment a good advertisement. Some of the most appropriate gifts will be found in our well selected line of finger rings, bracelets and new designs in brooches, etc., for graduation and wedding gifts. Clark & True, Middletown, Conn.

Stylish Fobs.—Most of the smart young fellows—and many of the smart old fellows—say that our new fobs are unusually pretty. One of the favorite designs consists of the conventional silk ribbon, with heavily gold plated disc, on which is engraved initials or monogram of wearer. Others have gold pendants set with carbuncles and other semi-precious stones. Prices range from \$1 to \$6. J. S. Baird, Watertown, N. Y.

Cut Glass Indicates Refinement.—It is a sign of an artistic temperament in those who desire to own it. It is useful, as well—a sensible, serviceable investment. We have a tempting array of "Hawkes" cut glass. Every design is new, and we can offer our customers some exceptional values. Many people hesitate at buying cut glass, on account of its supposed costliness—but dollar for dollar it reveals a richness that is possessed by few other articles of art or utility. Take a look at our window. You'll be interested. F. W. Sellers, Wichita, Kans.

Any man who is contemplating the purchase of an engagement ring should see the diamonds which we have specially selected for this purpose. Some of them are made up in three-stone engagement rings of great beauty. To see these gems is to realize that they are first quality. Johnston Bros., Montreal, Can.

1 2 3 4 5 6 7 8 9 0 1 9 0 8 A B C D E F G H I J K

Alphabet and Figures

FOR CLASS RINGS, EMBLEMS, ETC..

HERPERS BROTHERS,

SETTING MANUFACTURERS,

Newark, N. J.,

1 9 0 8

1 9 0 8 A B C D E F G H E T C . 1 9 0 8

JANITSCHKEK COMPANY, Inc.

33 UNION SQUARE, NEW YORK CITY

Manufacturers of Patented **DIES** for the Silver and Metal Trade

ARTISTIC CASTINGS OF EVERY DESCRIPTION FOR THE SILVER AND JEWELRY TRADE

Iron Hubs and Bronze Forces, False Core Work and Undercut Castings with Elastic Patterns. Fine Plaster Castings by the *Janitschek Patent* Superior to the Asbestos Process

TELEPHONE, 400 STUYVESANT

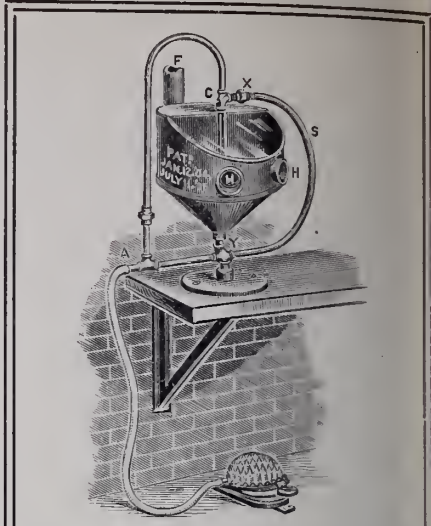

A Small Compound Sand Blast

Price, \$20.00 Foot Bellows, \$6.00

WORKS AS EFFECTIVELY WITH FOOT BELLOWS AS WITH POWER BLOWER ::::

MADE of Galvanized Sheet Iron, 10 inches diameter, Glass Top, Fittings of Brass and Iron, practically indestructible. Satisfaction guaranteed. Ask your Jobber for it, or write to us. Other Specialties: Zeuner's Best Jewelers' Saws; American Swiss Files, equal to the best imported; Gas Furnaces, for Melting, Annealing, etc., etc.; Positive Pressure Blowers.

E. P. REICHHHELM & CO.
JEWELERS TOOLS, FILES AND SUPPLIES
24 JOHN STREET, NEW YORK

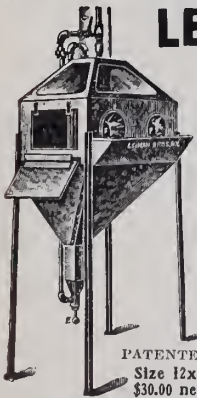

LEIMAN'S NEW SAND BLAST

SIMPLE EFFICIENT ECONOMICAL } Short, Straight Feed Pipes—CAN'T CLOG UP
Continuous Automatic Sand Feed—For RAPID WORK IN LARGE QUANTITIES

LEIMAN'S HIGH PRESSURE BLOWER

RUNS SMOOTH AND NOISELESS
Greatest Volume Highest Pressure No Springs or Delicate Parts to Get Out of Order

SEND FOR CATALOGS

LEIMAN BROS.

Brill St. and Bonykamper Ave., NEWARK, N. J.
139-143 Centre St., NEW YORK, N. Y.

Manufacturers of Jewelers', Silversmiths' and Metal Workers' Machinery, Tools and WORK BENCHES—Plants Equipped

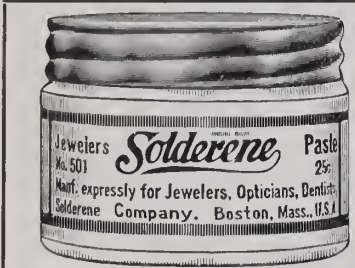

A PURE SOLDER IN PUTTY FORM

Apply to place to be soldered using iron or flame. Requires no acids, rosin, pastes or other fluxes. Absolutely neutral, preventing rust and corrosion. Saves time and waste. Large sizes for the manufacturing trade. If your jobber does not carry it in stock send us his name and 25 cents and we will send you No. 501 Jar, prepaid.

SOLDERENE COMPANY (Dept. 0)
91 Oliver Street, Boston, Mass., U. S. A.

Importer and Manufacturer of WATCH MATERIALS, TOOLS, JEWELERS' SUPPLIES AND OPTICAL GOODS



Bargains in Staking Tools

Prices on Application

Fine Gold, Silver and Platinum always on hand. Highest Prices paid for Old Gold and Silver.

A. ZAREMBOWITZ
250 East Houston Street NEW YORK

PLATINUM AMERICAN PLATINUM WORKS NEWARK, N. J.
NEW YORK OFFICE 41 Cortlandt Street



WORKSHOP NOTES AND QUERIES

Answers are also solicited from our readers to the questions published on this page.]

QUESTION No. 2084.—Japanese Alloys.—Will you please tell me of what the Japanese alloy known as shakdo is composed? Will appreciate any information which you can give on other Japanese alloys used for ornamental purposes. T. R. D.

ANSWER:—Shakdo, says Geo. Buchner, in *Die Metallfärbung*, is an interesting alloy of copper and gold, the proportion of gold being from 1 to 10 per cent. Articles manufactured of this alloy should be immersed in a caustic solution of sulphate of copper, alum and verdigris, which will impart to them a blue black color. By the application of this solution the copper on the surface of these articles is dissolved, leaving exposed a thin film of gold of a blue color, which is produced by the reflection of the light. The intensity of such reflection is graduated by the amount of gold in the alloy. In the case of the proportion of gold of one or two per cent. only, a rich bronze color is produced. Pure copper when acted upon by this caustic solution will impart to it an enameled appearance of a reddish tint. Shakdo is largely employed in artistic ornamentation, such as sword handles, buckles and ladies' vestments. *Giu shi bu ichi* (quarter silver) is an alloy of copper and silver which contains silver of about 30 to 50 per cent. This composition, when boiled in the caustic solution and used for ornaments, will assume a rich grey color which is much admired by the Japanese and is used for numerous fancy articles. Mokume is a name signifying a combination of numerous colored alloys of the metals, which produce a highly ornamental effect. Damascened articles are produced in the following manner: About 30 or 40 thin plates of gold, shakdo, silver, Rosette copper leaf and *giu shi bu ichi* are united in alternating layers and soldered together. This plate is pierced in various figures and lines, which plate is skilfully chased and hammered. When such pieces of metal are formed into ornaments etched in the caustic solution, the beautifully shaded lines of the different alloys are displayed with a most charming effect. To make karakane (bell metal), first quality, take 10 parts of copper, four parts of tin, ½ of iron and 1½ of zinc. For second quality use 10 parts of copper, 2½ of tin, 1½ of lead, ½ of zinc. Third quality: 10 parts of copper, three of tin, two of lead, ½ of iron, one of zinc. Fourth quality: 10 parts of copper, two of tin, two of lead. In producing bell metal the copper is melted first and the other metals should follow in rotation as given. The best bells are cast out of the first mixture, large bells out of the third. Karakane is used very extensively in Japan.

The solder for the different allows are as follows: For bell metal, 20 parts brass, 10 parts copper and 15 parts tin; for brass, 10 parts brass, 1½ of copper and six parts zinc; for silver, 10 parts silver and two to three of brass; for *giu shi bu ichi*, 10 parts silver, five parts brass and three parts zinc; for shakdo, three parts shakdo, best quality, and 10 parts zinc. Japanese copper articles are highly finished, and at times look as if they were enameled. This appearance is promoted by alloying the copper with red oxide of copper. They are then boiled in the caustic solution.

QUESTION No. 2085.—Cement for Imitation Pearls.—Please let me know of a good cement that will hold imitation pearls to a gold or filled ear stud. C. W. G.

ANSWER:—Major's cement is excellent for this work. Another cement for fastening pearls may be made of bleached shellac dissolved in grain alcohol or may be bought from watch material dealers, who generally keep a very fine white cement for sale, which is used by watchmakers and jewelers, and is the best cement obtainable.

Method of Producing Malleable Tantalum

TANTALUM is one of the most interesting of the rare metals. It is now employed in the production of the so-called tantalum lamp in which a filament of tantalum is employed instead of one of carbon.

According to the *Brass World* a process of making malleable and ductile tantalum has recently been patented by Marcello Von Pirani, Wilmerdorf, Germany, and assigned to the well-known electrical company of Siemens & Halske, Berlin, Germany.

Tantalum readily absorbs nitrogen, hydrogen or oxygen, so that it cannot be produced in the atmosphere. To make it, the inventor first produces tantalum hydride by heating tantalum chloride in hydrogen. If this tantalum hydride be heated in the air, it oxidizes, and if heated strongly in an atmosphere of hydrogen, the greater part of the hydrogen gas is given off and reabsorbed again upon cooling. The tantalum hydride is brittle and cannot be used. In order to obtain the malleable and ductile tantalum, the tantalum hydride is heated in a vacuum by means of an electric current so that it is actually raised to a white heat or above its melting point. The vacuum is maintained during the heating so that all gas that is expelled is removed.

The Nebraska Retail Jewelers' Association met in Lincoln, Nebr., Thursday, Feb. 20. The Nebraska Optical Society met Wednesday, Feb. 26.

Recent Researches in Silver Alloys.

It is my purpose to speak of silver alloys known as sterling silver, namely 925 parts fine silver and 75 parts of other metal or metals, for any other proportion would be quite valueless from a commercial standpoint. An alloy of silver below 925 could not be hall-marked or sold as sterling silver, and above that the increased cost would make it prohibitive. Thus we confine our research to 925 parts of fine silver and 75 parts of other metals. Copper and silver, regular sterling, is too well known to need any remarks save that this alloy produces fire scale and at times may be as hard as steel if not properly melted.

Iron and silver	will not alloy practically
Chromium and silver	“ “ “ “
Titanium and silver	“ “ “ “
Tungsten and silver	“ “ “ “
Vanadium and silver	“ “ “ “

Nickel and silver will alloy up to about one-half of one per cent., but on remelting



BUTTON.

the alloy separates and therefore is of no value. I have made a button of the alloy and the silver is found at the bottom as follows:

The silver at the bottom contained 2½ per cent. of nickel and the nickel at the top 15 per cent. silver; but on remelting the metals separated again and we find the proportions different with each melt.

Cobalt and silver, same melts as nickel and silver.

Manganese and silver alloy. The alloy is white, softer than fine silver, lacks temper, full of ruffles when rolled, is fireless.

Lead and silver; brittle and of no value, fireless.

Tin and silver; not so brittle as lead, no value fireless.

Antimony and silver; yellow color stain similar to tin, fireless.

Bismuth and silver; soft but rotten, fireless.

Zinc and silver; soft, tough, but lacks temper, fireless.

Cadmium and silver; soft, but becomes porous in working, also lacks temper, fireless.

Magnesium and silver; very similar to cadmium.

Aluminum and silver; aluminum makes silver muddy, sticks to the crucible and is of little value; the alloy is fireless.

The best alloy is copper with one-half of one per cent. of manganese used as a deoxidizer. One-half of one per cent. of cadmium is often used to make the copper alloy softer.

Manganese and zinc alloys with silver have recently been patented in America and Europe as a fireless product.—A. E. Hobson, in the *Metal Industry*.

The funeral of Walter Wells, a jeweler, who died in Vernon, Tex., was held in Kansas City, Mo., about a week ago. The deceased was the son of J. Z. Wells, of 2620 Prospect Ave., Kansas City. He is survived by a widow.

Libbey

"THE WORLD'S BEST"

CUT GLASS

Business Established in 1818

THE LIBBEY GLASS COMPANY represents almost a century of continuous devotion to the glass industry.

With such an experience ; with the finest facilities and the best workmen in the world—is it likely that any other cut glass can even approach its perfection?

The customer, nine times out of ten, KNOWS that no successful substitution is possible.

**Be sure the name "LIBBEY"
is graven in the glass**

The Libbey Glass Co.

TOLEDO, OHIO

NEW YORK SALESROOM, 57 PARK PLACE

THE CONNOISSEUR

Devoted to Art Pottery, China, Marbles, Bronzes, Cut and Decorated Glass Ware, Bric-à-Brac, Lamps, Art Metal Wares, Fancy Goods and Kindred Lines.

High Prices for Bristol Porcelain.

THE sale of a Bristol teapot on the 13th of last month for £441 has caused something like a flutter among dealers, and a sensation among connoisseurs, writes a member of the staff of the *London Pottery Gazette*. It has, at the same time, revived public interest in the products of the Bristol factory. All lovers of china—and especially of old china—are familiar with the high prices frequently obtained for pieces of Chinese and Sèvres porcelain. It will be remembered that in the Cockshut sale last year a Sèvres teapot was sold for £367 10s., but few persons were prepared to find that Bristol porcelain had acquired such a fancy value. After all, rarity more than quality governs the money value of old china. This is recognized by connoisseurs, and receives frequent confirmation by dealers at Christie's and other art sales-rooms—the sale we refer to is an instance.

It is difficult, he says, to account for the high price paid for this particular teapot, seeing that so recently as 1904 a complete Bristol tea service was sold for £162 15s. It is most likely it can be accounted for, though whether the secret will ever be made public is doubtful. The same teapot was sold at Sotheby's in 1871 for £190. When it was offered at Christie's last month, the first bid was 50 guineas, and in a few moments a spirited competition between Mr. Wills and Mr. Harding resulted in the purchase of the lot by the latter.

The pot and cover are 6½ in. high. It has a globular-shaped body, with rustic handles and spout and flattened dome cover, with flowers in biscuit porcelain. It has polychrome decoration—a full-length figure on each side. On one side a figure of "Liberty," holding a spear, surmounted by a Phrygian cap and a shield bearing the Gorgon's head; on the other side there is a figure of "Plenty," with a cornucopia—supporting a pedestal on which Hymen is standing with a flaming torch. The figures are white medallions on a bright ground of canary yellow. It is an allegorical subject, the conception of which is apparently more praiseworthy than the execution. There is a shield on the pedestal bearing the arms of Burke impaling Nugent, with emblematical figures and devices, and the date Nov. 3, 1774, in Roman numerals. The borders are of trellis design in brown, on canary ground, with scroll framework in gold.

The piece is known as the "Burke" teapot, and its history is briefly this: Richard Champion founded the Bristol pottery in 1773. In 1774 Edmund Burke was nominated as member of Parliament for Bristol, and a sharp contest followed, the result be-

ing that Burke was elected. He became acquainted with Champion during the contest. While staying in Bristol, Burke was the guest of Mr. and Mrs. Smith, of that town, and as a memento of the courtesy he had received from them and of his electoral campaign, he commissioned Champion to make a handsome tea service as a present for Mrs. Smith. That service is now historical. It then occurred to Champion to make another and finer tea service and to present it to Mrs. Burke. The teapot spoken of belonged to that set—hence its name—the "Burke" teapot.

Jeweler's Work in Life Membership Cards.

ANOTHER example of gold work in life membership cards is shown in the illustration herewith of the gold card presented by Keder Khan Grotto No. 12, M. O. V. P. E. R., of Syracuse, N. Y., to Charles H.

Reussow. The photograph is enameled on the gold. A large seal appears beneath the inscription.

This is the first card of its kind that has been gotten up for a Grotto Lodge, and folds on a hinge, so that it can be easily carried in the pocket.

Silver of the Duke of Gloucester.

IT is most interesting to note the changes in customs as the ages roll along. The reading of a very ancient document at all times evokes romantic thought and historic memories, but what a tragic chapter is reopened to us in a certain inventory existing in England—that of the personal belongings of no less a royal personage than the Duke of Gloucester. It dates back to the 14th century, and is of special interest to the jeweler and gold and silversmith as the following paragraphs will show:

The Duke of Gloucester—the youngest



GOLD LIFE MEMBERSHIP CARD MADE BY A SYRACUSE JEWELER.

Reussow. This card, which is designed and made by Arthur L. Bradley, of Syracuse, is of solid gold, all the lettering being engraved and enameled and the signatures appearing exactly as if they were written by the men in whose handwriting they purport to appear.

The card has a portrait of Mr. Reussow in the corner and the emblem of the organization on the other side, the latter being enameled in red and white. The

son of Edward III., King of England, was born in 1355. In 1386, history tells us, he became head of the Council of Regency. In 1397 he was seized and tried. He is said to have confessed his political misdeeds, and was taken to Calais, where he was smothered. In due course the unfortunate duke's property was seized by the "Escheator," and, of course, a full inventory of his "goods and chattels" had to be taken.

(Continued on page 111.)

C. DORFLINGER & SONS

36 MURRAY STREET

NEW YORK



Hand-Made Blanks only.
Cut, engraved and etched
glass. Light, medium
and heavy stemware,
tumblers, etc.



My Stock

of exquisite and unusual
effects in FANS is, as
usual, the Most Complete
in this country.

Louis Steiner

FANS And Novelties for the Jewelry Trade **520 and 522 Broadway
New York**



35 MAIDEN LANE

Manager
New York Office
for

MIDDLETOWN SILVER CO.

Silver Plated Hollowware

O. F. EGGINTON CO.

Exquisite Cut Glass

CORNING CUT GLASS CO.

Popular Specialties

ROGERS SILVERWARE

Write for Prices

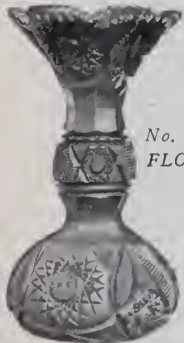

No. 1085.
FLORENCE.

Owanda Cut Glass Co.

Manufacturers of

Rich Cut Glass

Originators of New Designs

HONSDALE, PENNSYLVANIA

A complete line of our high-grade goods shown at our
New York Office, 68 West Broadway.

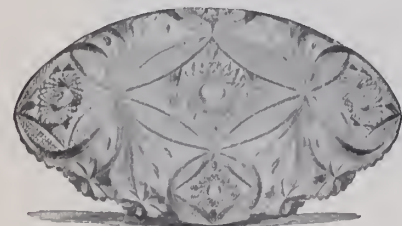

"Wild Rose," No. 122—14-inch
Ice Cream Tray

Irving Cut Glass Co. Inc.

Manufacturers of

Artistic Cut Glass

HONSDALE, PA.

F. W. REICHENBACHER
New York Representative 59 PARK PLACE

The St. James

Cor. Walnut and 13th Sts., Phila., Pa.

THE IDEAL HOTEL OF
THE QUAKER CITY

A spacious fire and burglar proof
safe has been provided for the con-
venience of the trade. Palatial
rooms with bath \$2.50 per day
and up. Rooms without bath,
(running water) \$2.00 and up.

EUGENE G. MILLER, Mgr.

Established 1879

Manufacturer of

LOUIS W. HRABA Fine Leather Goods

29 East 19th St., New York

Exclusively for the Jewelry Trade

JACOT MUSIC BOX CO.

MIRA MUSIC BOXES
AND MIRAPHONES

39 UNION SQUARE - NEW YORK.

How Jewelers Sustain Loss in Their Repairing Business.

HERE is a movement on foot among retail jewelers throughout the country to obtain laws governing the matter of goods which are left with them for repair and are never called for, says the Newark, N. J., *Evening Call*. It is said that nowhere is there any law which adequately protects the storekeeper, whether he be a general dealer in jewelry or the proprietor of a repair shop, from loss in various ways, not the least of which is that he may have tied up at one time repair work amounting to several hundreds of dollars, without any safe way in which to get his money out of the goods.

He has, usually, a contract with the person leaving a ring, brooch, pin, watch, spectacles, eyeglasses, fountain pen or other article to be repaired, in which it is set forth that he will not be responsible for goods left over 30 days, but the instances in which the goods are disposed of at the end of that time for the benefit of the jeweler are rare. Besides, it is said to be doubtful if the contract, which is embodied in a brief statement on the numbered ticket which is given by the jeweler to his customer, would hold in a suit at law. Even if the jeweler takes advantage of the contract and is willing to legally defend it if necessary, the goods must be advertised for a given number of times and a certain period of time before they can be sold, and there are State laws governing all kinds of goods, left with business men under various circumstances, which must be conformed to, as there are no exemptions or special regulations for jewelers.

Newark retail jewelers and repair men complain of existing conditions in those respects just the same as jewelers elsewhere, and they tell some queer stories in connection with their repair work. The most important feature to them, however, is the fact that no matter when or under what circumstances they dispose of goods left with them, they are likely to have a claim made by the owner. Whatever the circumstances may be, any litigation of the matter means expense and unpleasant notoriety and possibly the substantiation of the claim of the owner in the end by the courts. For that reason a great majority of claims for goods left for repair which have for any reason or in any manner gone out of the hands of the jeweler are usually settled by the latter on the best terms he can make.

Inquiry among some of the retail jewelers of this city who do repair work has developed the surprising fact that it is no uncommon thing for men, women and children to leave the articles with the jeweler for from a few months or a year after they are repaired to a period of five, six or seven years before calling for them. Owing to that fact, practically every jeweler has continually on hand a stock of second-hand goods which represents to him from \$50 to several hundred dollars, according to the extent of his business, in money to be collected in repairs, and often means that he has the care of thousands of dollars' worth of goods belonging to other persons. Under the law he must protect them from fire and burglary and care for them in every way,

just as carefully as he does his own first-class stock.

One Newark jeweler last week walked to a drawer in his repair department and, pulling out a small box containing an array of dust-covered envelopes, remarked: "Those are spectacles and eyeglasses. They represent to me over \$150 for repair work done on them. All of them are in excellent condition and should be of value to the owners. They are worthless to me, as there is no market at the end of a year or at any other time for second-hand eyeglasses. Some of the articles in that box have been here for six months, and the time which others have been in my possession runs up to two or three years. I must have them in readiness to hand over whenever the owners appear to claim them, but if they never appear I am put to a dead loss of the time and money actually expended for the repairs, to say nothing of the small profit which is involved."

Turning to a wall case which contained several scores of gold and silver watches of all sizes, makes, styles, conditions and degrees of value, the same dealer continued:

"The length of time I have had those watches in my possession varies from three months to three years or more. The amount of repair work which they represent is several hundred dollars, but instead of getting a profit out of them they are thus far dead loss to me of just that much money, to say nothing of the time and effort which myself and my employes have to devote continually to their care. At a sale I would get more than my money out of some of them, while out of others I would get really less than my charges as shown on the attached tickets. But I am not selling them. Just as sure as I do, the owners are likely to return for them. They will accept no explanation, and will insist upon having their watches returned to them or the equivalent in cash—not what the timepieces were actually worth when brought to me, but what they cost, or the value, sentimental and all, which is put upon them by the owners. I've been stung once or twice rather than go into court, so I don't sell or otherwise dispose of them. But is it fair that myself or any other jeweler engaged in the repair business should be compelled to assume such a costly and risky burden for other people? I, for one, hold that it is not, and I am glad to see that a country-wide agitation has been started for the purpose of obtaining laws for that phase of the jewelry trade which will be more equitable to the jeweler and under which the customer will not have all the good end of a proposition which grows entirely out of the carelessness of the latter. The only good we can get out of the watches now is by taking a chance and lending them to customers for whom we are repairing other watches."

In a box, kept in a safe, the jeweler had other watches, all of which had been left in his care for longer periods than those which he still kept on the rack over the repair benches. Some of them had been in the possession seven or eight years, and he still lives in hope that they will be called for some day. In still another box he had brooches, chains, rings and other articles, varying in value from a few cents to \$25 or more, and there was the same story to tell

about them as about the eyeglasses and watches.

"We find by experience," he said, "that many causes contribute to our accumulation of property belonging to others which originally comes into our hands for purposes of repair. Some persons lose their tickets and then actually forget where they left the articles. Others move away, and in the excitement of leaving the city or the country fail to think anything about the article of jewelry which they took to the repair man. Still others become hard up for money after having taken the article to be repaired and find that they are better able to get along without it than to pay for the work which has been done on it.

"Another class of customers will come in after the work is done, inspect and admire the repaired or refinished article and remark that they will be in within a day or two to get it, and that is the last we ever see of them. We never know whether the work is unsatisfactory or whether something suddenly happened to the owner which compelled him or her to abandon the article. There are many other reasons, apparently, why people leave their jewelry for months and years, and some of them forever, in a repair shop. It is an important matter in the jewelry trade and we will welcome any form of legislation which may be decided upon to remedy the evil."

Silver of the Duke of Gloucester.

(Continued from page 109.)

And it is this document, still existing, that affords such interesting reading. Every page of the many folios describing, more or less minutely, the furniture, carriages and other household equipment of the royal prisoner gives every reader (who can understand it—for it is in Latin) a fund of instruction as to the elaborate outfits the mighty of those days enjoyed. But of especial value to THE CIRCULAR-WEEKLY'S readers are the items in silverware of the duke enumerated in the catalogue.

In it we find "Two silver candlesticks, weighing 4 lbs. 3½ ozs.; a 'holy water stopp' and sprinkle of silver gilt, weighing 3 lbs., 2½ ozs.; a 'senser' with four chains of silver, and a ship and spoon for the incense of silver parcel-gilt; two silver cruets and a chalice wholly gilt." The other plate was as follows: "Basins and ewers, pottlepots, chargers, platters, salt cellars, spoons, masers," etc.

How many of us these days can define the meaning of "pottlepots, chargers and masers"? One "maser," we are told, was of unusual size and held three gallons. It had a band and "embossed print of silver-gilt." This weighed 8 lbs. 5 ozs. It had also a cover of silver-gilt weighing 6 lbs. 5½ ozs. The last item on the silverware list is "a large alms dish in the shape of a ship, weighing 10 lbs." It was valued by the escheator's appraisers at £14. This is equal to \$300 of our present values.

An extended interview with John C. Pierik, Springfield, Ill., on the trend of fashion in jewelry, was published in a recent issue of a local daily newspaper.



Battle of Hastings

BAYEUX TAPESTRY
UNDERGLAZE ENAMEL

is the latest production of the **Royal Doulton** factories. Exquisitely enameled in rich colors.



SERIES No. D2873

Sole Agent

W. S. Pitcairn

44 Murray Street
New York

Write for Booklet, "Quaint Bits of Royal Doulton"

JEWELERS' SHOW CASES.

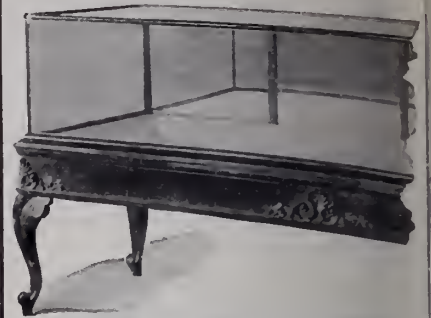

Our Small ROSEWOOD MOULDING STEEL LINED CASE. We Challenge the World to Produce a Better Case

F. C. JORGESON & CO.

11-17 N. ANN ST., CHICAGO

Makers of all Kinds of

JEWELERS' FIXTURES

Write for Illustrated Circular

Our Motto: *The Best of Everything*

The Universal

Runs on edge of stone and sharpens the graver across the point, leaving no scratches running from the point back. The result is a bright, smooth cut.



Price, \$2.00

Hight Mfg. Co.
Sole Manufacturers
Decatur, Ill.

For Sale by

- A. C. BECKEN CO., Chicago, Ill.
- SWARTCHILD & CO., Chicago, Ill.
- E. & J. SWIGART CO., Cincinnati, O.
- F. J. BOESSE & CO., New York.
- NORDMAN BROS. CO., San Francisco, Cal.
- LEONARD KROWER, New Orleans, La.
- H. S. MEISKEY CO., Lancaster, Pa.

STYLE No. 79.

JEWELERS' Store Fixtures

Made to order

WADELL SHOW CASE CO.

Near Mt. Elliott, DETROIT, MICH., Dept. I.

LEATHER WATCH BRACELETS

Send for assortment on Display Card

ESTABLISHED 1850

C. F. RUMPP & SONS

Manufacturers of FANCY LEATHER WARE

PHILADELPHIA

New York Salesrooms, 683 and 685 Broadway

TRADE MARK

CROUCH & FITZGERALD

Jewelry Trunks and Cases

177 Broadway,
Bet. Cortlandt
and Dey Sts.

688 Broadway,
723 6th Av.,
New York.



Jewelry Store Fixtures and Show Cases

OUR SPECIALTY

The enlargement of our factory in our new location enables us to quote low prices.

If you need fixtures or show cases let us hear from you. Estimates cheerfully furnished.

ALEXANDER H. REVELL & COMPANY, Rees, Dayton, Eastman and Hawthorne Sts., **CHICAGO, ILL.**



LEMAIRE OPERA GLASSES

LEMAIRE FIELD GLASSES

Best in the World. Used in the Army and Navy.

SUSSFELD, LORSCH & CO., Importers

37 MAIDEN LANE, NEW YORK

MARQUE DE FABRIQUE



All Genuine Glasses
Bear This Mark
Large Variety in All
the Latest Styles

THE WASHBURN

SECURITY **MAGIC NUT**
Automatic Holder for ear studs, scarf-pins etc.
for all sizes of scarf-pin wire. Guaranteed.



EAR WIRES
for unpierced ears.



SAFETY CATCH
For Brooches, etc.
Can be applied to any work where pin tongues are used.

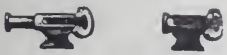

Open. Closed. Open. Closed.
Descriptive Circular on Application.
Pearl Drilling and Adjusting a specialty.
Special Order Work and Repairing.
C. IRVING WASHBURN, 12-16 John St., N. Y.

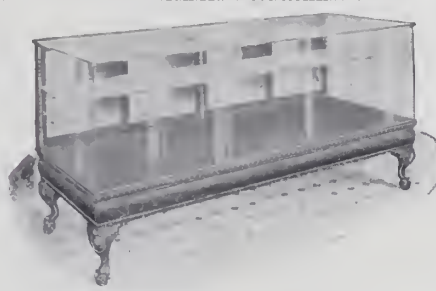

"American Beauty" Table Display Case No. 408

The Store Beautiful

Means increased business—Success. We can make your store Beautiful and at a small cost.

Write for Catalogue C and information

GRAND RAPIDS SHOW CASE CO.
GRAND RAPIDS, MICH.

New York Office: 750 Broadway (same floor as McKenna Bros. Br. & Co.) (Under our own management)
St. Louis Office: 1331 Washington Ave.
The Largest Show Case Plant in the World

ESTABLISHED 1886

GEO. M. BAKER

TELEPHONE UNION 1493-R

Gold and Silver Refiner and Sweep Smelter

Office, 91 Page St. }
Works, 77-85 Page St. } PROVIDENCE, R. I.

Our processes are strictly up to date and facilities most complete for doing all kinds of refining.
Specialties: Prompt and good returns.

PATENTS

obtained on inventions and designs. Trade-marks, prints and labels registered.

R. W. BISHOP,

ATTORNEY-AT-LAW,
908 G Street N.W., Washington, D.C.



HERMAN KOHLBUSCH, Sr.,
ESTABLISHED 1859.
Manufacturer of Fine Balances and Weights
for every purpose where accuracy is required.

Office and Salesroom, 194 BROADWAY, NEW YORK.
Send for Price List. Tel. 370 Cortlandt.



WM. BOLLES' SELF-FILLING NON-LEAKABLE FOUNTAIN PENS



SIMPLE—CLEAN—PRACTICAL

We make our own goods—and they have stood five years' test by the largest dealers in the country. Write for Catalogue and Price Lists.

THE WM. BOLLES CO., 1108 JEFFERSON ST., TOLEDO, OHIO

MR. OPTICIAN:

Our new catalog is ready for distribution—it will be found of real interest to you. Will send you a copy free—if you will tell us who and where you are. Ask for Catalog "O." Address:

WILLIAM DIXON, INCORPORATED

39 JOHN STREET, NEW YORK
Formerly F. W. GESSWEIN COMPANY



Enough metal is often lost in the careless reduction of **Filings, Waste, Scraps and Sweeps**

to cover the cost of the work. We are careful and considerate enough to overcome this loss, thus enabling you to meet the expense out of a surplus that is ordinarily lost.

Try us and see if it isn't so

No. 236 Eddy St., **CONLEY & STRAIGHT**, Providence, R. I.

Gold and Silver Refiners, Assayers and Sweep Smelters, Dealers in Fine Gold, Silver and Platinum, all kinds of Gold and Silver Anodes.

WM. F. RENZIEHAUSEN CO.

'Phone 3759-R.

43-47 Oliver Street, NEWARK, N. J.

Gold and Silver Refiners

PROMPT RETURNS MADE FOR ANY MATERIAL CONTAINING PRECIOUS METALS
DEALERS IN GOLD AND SILVER, AND ROLLERS OF STERLING SILVER

Gold and Silver Anodes a Specialty

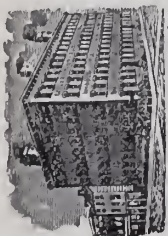

L. LELONG & BRO.

Gold and Silver Refiners, Assayers and Sweep Smelters

S. W. Cor. Halsey and Marshall Sts., NEWARK, N. J.

Prompt attention given to Gold and Silver Bullion.

SMELTING FOR THE TRADE.

CRUCIBLES.



Jewelers' Supplies,
Etc.

Established 1850.

J. & H. BERGE,
96 John Street,
NEW YORK.



PRACTICAL COURSE IN ADJUSTING.

Published Price, \$2.50.

Special Reduced Price, \$1.50, Postpaid.

All Jobbers or Jewelers' Circular Publishing Co



WE BUY

Old Gold and Silver Filings, Polishings, Sweeps, Hand Washings, etc. We will make accurate valuations and hold consignment subject to your acceptance. If valuation is not satisfactory, we reship to you at our expense.

WE PAY FOR OLD GOLD:

22 K. 88c. per dwt.	12 K. 48c. per dwt.
20 K. 80c. " "	10 K. 40c. " "
18 K. 72c. " "	8 K. 32c. " "
16 K. 64c. " "	6 K. 24c. " "
14 K. 56c. " "	4 K. 16c. " "

MARKET RATES FOR SILVER AND PLATINUM.

Try us and you will Appreciate our Squareness, Promptness and Accuracy.

T. B. HAGSTOZ, Ltd., Main Office, 709 Sansom St., Philadelphia, Pa.
SMELTERS, ASSAYERS, REFINERS.

WE SELL

Gold, Silver and Platinum, various qualities, rolled flat or drawn to wire of any gage.

PRICES OF ALLOYED GOLD:

8 K. 42c. per dwt.	14 K. 66c. per dwt.
10 K. 50c. " "	16 K. 74c. " "
12 K. 58c. " "	18 K. 82c. " "

Gold and Silver Solder, either from formulas furnished, or our own. "T. B. H." Alloy, 25c. per oz. Guinea Gold, 75c. per lb. Shot Copper, 40c. per lb. We will send tables for alloying without charge. They save figuring.

The Ackley Engraving Block

AND "JOKER" ATTACHMENT

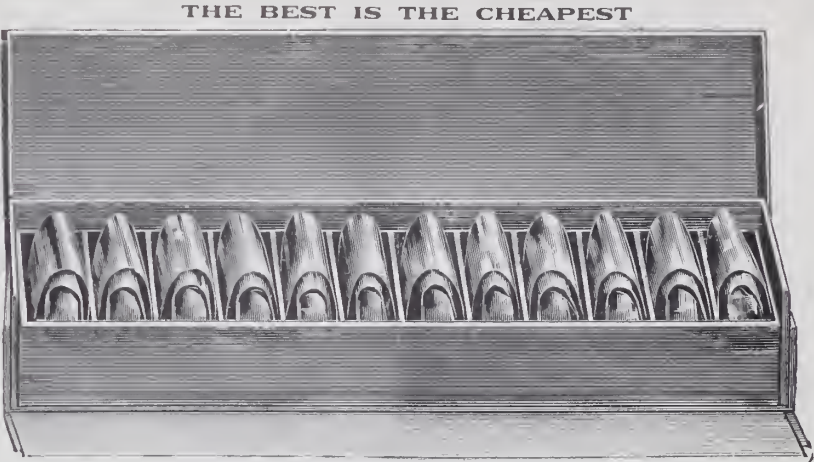

THE BEST IS THE CHEAPEST

Why the "LAFAYETTE MAINSPRING" is superior

1st—It is guaranteed to be made of the Best Steel. 2d—It is made by Skilled Hand Labor. 3d—Each Spring is wrapped in Oil Paper and Silver Foil, which packing positively avoids exposure to the moisture of the air, and therefore all danger of rust is prevented. 4th—Each Spring bears a metal Tag, indicating the watch it is intended for, which accuracy is warranted. 5th—Each dozen is put up in a neat Box, having twelve partitions, one for each spring, so the handling of several springs at one time is avoided. 6th—The finish of the "Lafayette Spring" is, like its quality, superior to any in the market.

THE ACKLEY ENGRAVING BLOCK: Always ready to hold any article. No hunting for pins. The patent friction pins all remain in the head. Simply pull up to the desired height the ones needed. Each pin is numbered on top to designate size of groove or notch in it. They are so arranged in the head that they will readily hold all large or small articles either by three or more points of contact. The swivel jaw can be locked rigidly in an instant. The key will not fall off, yet it may be removed instantly. The patent base eliminates all unnecessary weight and gives the same movement as the old ball and socket base. This block is the result of years of practical experience of engravers who know the wants of engravers. There is nothing complicated about it to wear out or get out of order. Workmanship and materials are the best. Each part is copper plated before being heavily nickel plated, thus insuring a fine durable finish. Height, 6 3/4 inches. Diameter of head, 2 5/8 inches. Diameter of base, 6 inches. Weight, 8 pounds. THE "JOKER" ATTACHMENT, as shown beside the block, holds large and small signet and band rings, cuff buttons, collar buttons, signet pins, etc., firmly, without marring. It may be used on any block.

Pat. March 20, 1906
 Made by Engravers who saw the need
 of a Handy Time Saving Block

HENRY ZIMMERN & CO., Inc., 77 John Street
 New York City
 Exclusive Wholesale Distributors for U. S. and Canada

ARTHUR MARSON

INC.

MAKERS OF

Swivels, Spring Rings, Snaps and
 Specialties in the Line, in GOLD
 and PLATINUM

Manufacturers of the
 SMALLEST SPRING RING
 on the market for Neck Chains

SEND FOR SAMPLES

23 MARSHALL ST., NEWARK, N. J.

JOHN AUSTIN & SON

Assayers, Refiners and Smelters

74 & 76 Clifford Street PROVIDENCE, R. I.



We Do Our Own Smelting.

Frank Dederick.

Established 58 Years.

James E. Dederick

James H. Dederick's Sons,

Assayers and Bullion Dealers.

All qualities of Gold and Silver, in Plate, Square and Round Wire, Rolled to any gauge.
 We are selling fine gold for \$1.04 per dwt. which we guarantee to be government assay bars.
 Small rolling for the trade.

ALL QUALITIES OF GOLD AND SILVER SOLDER.

16 Maiden Lane

NEW YORK.

We buy Old Gold and Silver.

CASTINGS

Gold, Silver, Bronze, Brass,
 German Silver, Copper and Iron.

L.D. TEL. 2072 L. Supply Jewelers, Silversmiths,
 Die-makers, Mould-makers, etc. Bronze Forces, Hard
 Bronze and Iron Shells for Die-cutting Machines.
 Cast Iron Hub for sinking in Steel Dies. Chandelier,
 Undercut Work, Statuary.

AUGUST GRIFFOUL 313 HALSEY STREET
 NEWARK, N. J.

UNITED STATES SMELTING AND REFINING WORKS

L. & M. WOLLSTEIN

16 JOHN STREET, NEW YORK

SWEEP SMELTERS AND ASSAYERS

Dealers in Gold and Silver Assay Office Bars. HIGHEST and MOST PROMPT RETURNS made for Sweeps
 and all kinds of Waste containing precious Metals.

HIGHEST PRICES PAID FOR OLD GOLD AND SILVER

Manufacturers of STERLING SILVER.

Importers of PLATINUM.

Ore and Bullion Assays a Specialty.

A Few Words About Mainsprings

Spectacle and Eyeglass Strap Plier No. 105

Price, each, \$1.25

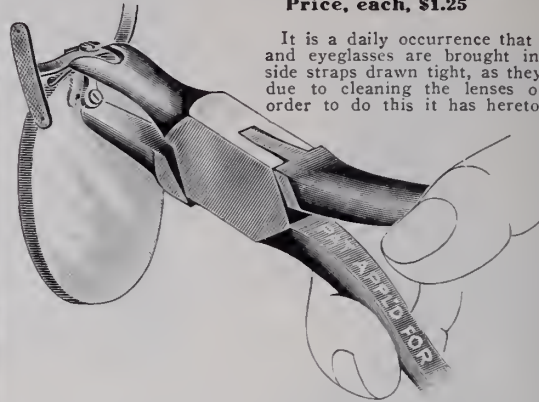

It is a daily occurrence that frameless spectacles and eyeglasses are brought in to have the small side straps drawn tight, as they have become loose, due to cleaning the lenses or other causes. In order to do this it has heretofore been necessary to remove the lenses from the mountings, and as all know, this very often results in breaking or chipping the lenses.

By the means of this plier this can be avoided and the work quickly done.

All that is required is to loosen the screw two or three turns, clamp the frame as shown in the illustration, and bend the straps to the lenses. Retighten the screw, and the work is done.

DO NOT NEGLECT to loosen the screw, as otherwise a good job cannot be done, and the lenses are likely to be broken.

Made of best quality Swedish steel, nickel-plated.

There is no article of material used by the watchmaker or the watch repairer about which, if he be a careful and thorough workman, he feels more solicitous than the *Mainspring*. Next to the fragile watch glass, the mainspring is more frequently replaced than any other article used in watch repairing. While the percentage of breakage is high in all watch springs, it jumps into appalling proportions when they are of an inferior quality, unless their temper is so low as to make them almost useless, and certainly of little value in watches that are to serve the purpose of timekeepers. When we offer you the *Ulysse Sandoz Robert* spring, we feel confident that you are getting the best that skillful hands and lifelong experience can produce.

Made for all American Watches. Per dozen, \$1.25

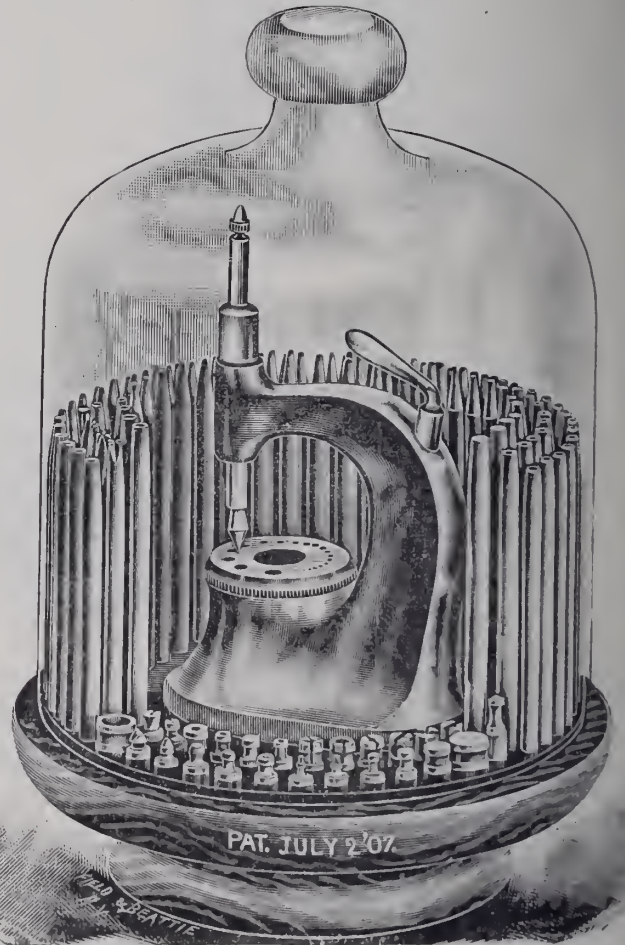
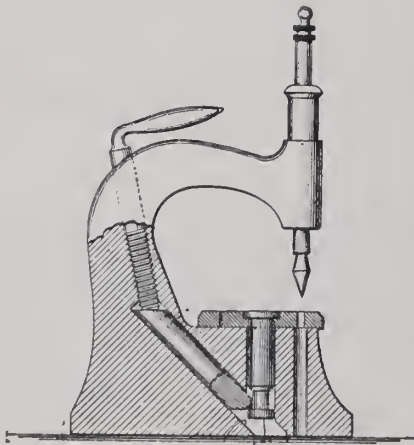

“Echarco” Staking Tool

100 Punch, 24 Stumps - - - - - Each \$16.00

This invention is a decided improvement in staking tools. In the usual construction, the die is held by means of an eccentric cam, which has always been found insufficient, and objectionable, as the blows of the hammer nearly always loosen the cam, and the die plate is permitted to tilt and move out of position. Any mechanic will see, at a glance, from the above sectional view, that a loosening of the bolt is an absolute impossibility, no matter how severe the pounding may be, and that the source of existing staking tool troubles is entirely eliminated.

FOR SALE BY ALL JOBBERS IN THE UNITED STATES AND CANADA

HAMMEL, RIGLANDER & CO. 47-49 Malden Lane
New York

THE

JEWELERS' CIRCULAR

WITH WHICH ARE CONSOLIDATED

THE HOROLOGICAL REVIEW,
THE JEWELERS' WEEKLY,
THE JEWELERS REVIEW

Copyright 1908 by
The Jewelers' Circular
Publishing Company.

11 John St., Corner Broadway, New York.

Entered as second-class matter at the New York, N. Y., Post Office.

40th Year

WEDNESDAY, MARCH 11, 1908.

Vol. LVI., No. 6.



Silver Nef Presented to Manager of a German Steamship Company.

(See Text on Page 35.)

ALVIN SILVER

"ORANGE BLOSSOM"



ALVIN

MFG. CO.



Cucumber Server

Sterling
Silver

The true test of a design in table silver is the effect produced when the table is arranged for formal hospitality.

Pieces of the Orange Blossom design, shown above, make a most attractive group.

This design is made in over one hundred different articles, and is especially suited to wedding gifts.

It is made in sterling silver, stamped with the above trade-mark, and can be obtained from any jeweler, in sets or single pieces, to meet the requirements of complete service.

"BRIDAL ROSE"



ALVIN

MFG. CO.



Butter Knife

Sterling
Silver

The true test of a design in table silver is the effect produced when the table is arranged for formal hospitality.

Pieces of the Bridal Rose design, shown above, make a most attractive group.

This design is made in over one hundred different articles, and is especially suited to wedding gifts.

It is made in sterling silver, stamped with the above trade-mark, and can be obtained from any jeweler, in sets or single pieces, to meet the requirements of complete service.

The two most appropriate patterns of Sterling Silver Flat Ware for wedding anniversaries. These patterns are being advertised in the leading magazines to stimulate trade, and so help the retail jewelers.

These magazines will be read in millions of homes all over the United States.

Be prepared to meet the demand. Complete your stock with fancy pieces and cutlery.

ALVIN MFG. CO., Silversmiths, NEW YORK

FAHYS PERMANENT CASES



They have solid gold joints and solid gold French bows. French bows are stronger, as well as more artistic.

JOSEPH FAHYS & CO.

New York

Boston

Chicago

San Francisco

"STRIKE WHILE *the* IRON *is* HOT"

Make Money --
Good
Honest
Dollars



By buying diamonds from us you get the best value obtainable, so you can sell them at a fair profit, and at the same time give your customer proper value for his money

J. R. WOOD & SONS

DIAMOND CUTTERS

2 Maiden Lane, Corner 170 Broadway

NEW YORK

SAFETY



Perfect Safety

from dissatisfied customers is assured to those retail jewelers who handle our wedding rings.

Don't be left "out at sea" by selling rings not up to quality represented, or cast rings that do not wear properly.

We invite you to "ride ashore" to absolute safety.

J. R. WOOD & SONS

WEDDING RING MAKERS

2½ Maiden Lane Corner 170 Broadway

NEW YORK

The Big Dipper

Will Dip Up Profits For You



THE
BEST IN EVERY
GRADE

CHICAGO
701 Heyworth Bldg.

Ask your Jobber

NEW YORK
Maiden Lane

STARWATCH CASE CO.

LUDINGTON, MICHIGAN

COPYRIGHTED BY T. F. KENNEDY.



Flat Belcher ring as received with claws badly worn.



How the same ring looks when stone is reset without new claws. Stone is not secure and point is below inside of ring.

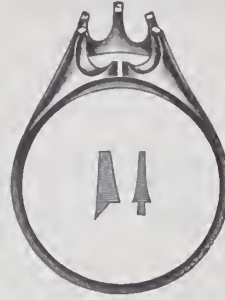

How we splice settings and solder in new claws; seams do not show and rings are as perfect as when originally made.



How ring looks with new claws and stone securely reset. Entire ring is finished like new.

When we tell you that we have received as many as 75 diamond rings in one day for new claws and settings, you will not think us extravagant for using a full page in THE JEWELERS' CIRCULAR to exploit this feature of our business, but will wonder if you are getting your share of claw work.

99 out of every 100 owners of diamond rings willingly pay \$1.50 to \$5 for new claws or settings on their rings, but would not buy new mountings for \$5 to \$25.

It is worth while to familiarize yourself and your employees with this work, as it is one of the important little things that helps to make your business profitable.

WENDELL & COMPANY

The firm that did much to change the repair end of the Retail Jewelry Business from a source of worry and dissatisfaction to one of pleasure and profit.

103-105 William Street
New York

TWO WONDERFUL SHOPS

57 Washington Street
Chicago



Tiffany ring as received with worn off claws. Stone cannot be reset, as it would be too low to look well and the point would come below the inner circle of ring.
(See cut No. 2 of flat belcher.)

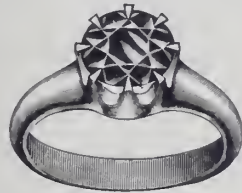

How same ring looks with new claws and stone securely reset. Entire ring is finished like new.



Oval Belcher ring as received with claws badly worn. Stone cannot be reset, as it would be too low to look well and the point would come below the inner circle of ring.
(See cut No. 2 of flat belcher.)

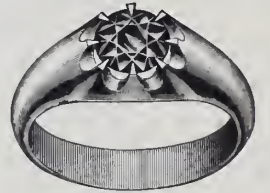

How same ring looks with new claws and stone securely reset. Entire ring is finished like new.

THE PRICES QUOTED ABOVE FOR NEW CLAWS AND SETTINGS ARE SUBJECT TO OUR CATALOGUE DISCOUNT.

WE CAN PUT NEW CLAWS AND SETTINGS ON MOUNTINGS TAKEN IN TRADE AND REFINISH THEM SO THEY WILL BE AS GOOD AS NEW.

WE RETIP CLAWS AND MAKE NEW SETTINGS FOR CLUSTER MOUNTINGS SO THEY ARE AS GOOD AS WHEN ORIGINALLY MADE, AT PRICES THAT MAKE IT ADVANTAGEOUS FOR THE OWNERS TO HAVE THIS WORK DONE.

Carrying no diamonds in stock, entering and tagging each piece of diamond jewelry as received, then giving to each workman but one ring at a time, which is returned before he receives another, prevent any possibility of diamonds being exchanged while in our possession.

Buckles



OUR BUCKLES are dress accessories that beautify what is already pretty in apparel. They constitute a welcome addition to the plainest garments or meet the strangest caprices of a strangely capricious sex—such are the volume and variety of our line. The range develops from buckles of Puritan simplicity to those elaborate curves and scrolls affected at the present time. All designed within the bounds of propriety, and calculated to please alike the exacting and indifferent. Etched, Plain, Fancy Die and Hand Engraved. Illustration, No. 2896, actual size; No. 2897, smaller size, same design. We also make these in belt pins. Sterling Silver of substantial weight.

Established 1861

R. BLACKINTON & CO.

TRADE  MARK

SILVERSMITHS

3 Maiden Lane, New York

Factory: North Attleboro, Mass.

WHITING MFG. COMPANY

Silversmiths



The Situation

The Whiting Company, being in close touch with the jewelry trade of the entire country, naturally find themselves exceptionally well informed as to the prevailing business conditions and sentiment.

This knowledge leads them to the belief that in these times of "close buying" it is incumbent upon the retail dealer to make his stock more than usually attractive by the addition to it of such goods as shall compel his customers' attention.

For this reason the Whiting Company have confined themselves this season to the production of such goods as shall be absolutely convincing, owing to their moderate price combined with their excellence of quality and individuality of design.

BROADWAY AND NINETEENTH STREET
NEW YORK

SAN FRANCISCO, CAL.
717 Market Street



The Home of The

DUEBER-HAMPDEN

COMPLETE WATCH

(Filled 25 Yr Cases.)

Attention is called to
Solid Gold, 12 Size
Cases on another
page.

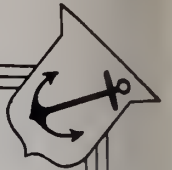

The tendency
is toward smaller
watches.
Nothing so satis-
factory, in a small
watch, as a
DUEBER-HAMPDEN.



JOHN HANCOCK. 12 SIZE.
COMPLETE. (Cased at factory.)



Wolcott Manufacturing Co.



“Fashion”

Collar Pins



PATENTS PENDING

An Absolutely New Article which Sells at Sight. Try It.

MANUFACTURED IN ROLLED PLATE BY

Wolcott Manufacturing Co.

71 Peck St., Providence, R. I.

New York Office, 14 Maiden Lane

MANUFACTURED IN 10KT. SOLID GOLD BY

JOHN T. MAURAN MFG. CO., Providence. R. I.



No. 3542.

Made in Nickel-Plate, Copper and Silver-Plate.

PALATABLE LUNCHES

At home enhance the pleasure of an evening's entertainment.

The Chafing-dish enables the hostess to prepare lunches quickly in a variety of ways and to show her skill in cookery.

Sternau Chafing-dishes being original in design and workmanship, ornamental as well as useful, appeal to those wishing high-grade wares.

Every jeweler should stock Sternau Chafing-dishes, as they are salable *throughout* the year.

If It Burns Alcohol, We Make It

S. STERNAU & CO.

New York Showrooms
BROADWAY, COR. PARK PLACE
Opposite Post-office

Makers of Coffee Machines, Chafing-dish Accessories, Alcohol Stoves, Smoking Sets, Fancy Teakettles, Baking Dishes, Etc.

Office and Factory
195 PLYMOUTH STREET
BROOKLYN, N. Y.



NEW YORK, 9 Maiden Lane
CHICAGO, 103 State Street

BATES & BACON ATTLEBORO MASSACHUSETTS

THE LEADING HOUSE FOR HIGH-GRADE GOLD-FILLED CHAINS, LOCKETS AND BRACELETS

Something New for Easter!

THE "WINNA" BRACELETS
Strongest secret joint and catch on the market

SOME OF OUR NEW DESIGNS
ORDER OF YOUR JOBBER

- GENTS' VEST
 - DICKENS
 - SAFETY FOB
 - SECRET LOCKET
 - LORGNETTE
 - EYE GLASS
-) CHAINS

BRACELETS, LOCKETS, CHATELAINES

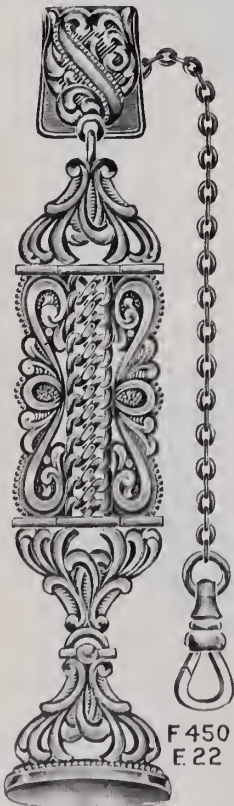

F 450
E 22

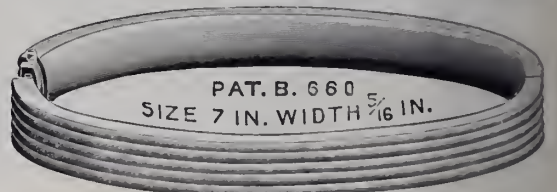

PAT. B. 660
SIZE 7 IN. WIDTH 5/16 IN.

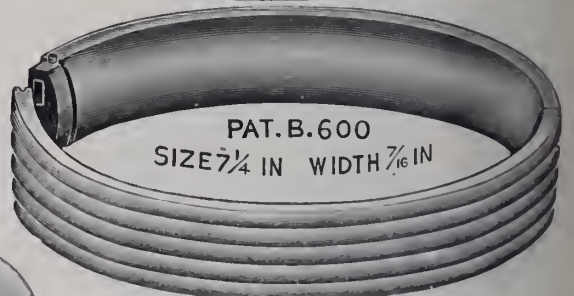

PAT. B. 600
SIZE 7 1/4 IN. WIDTH 7/16 IN.



PAT. B 662
SIZE 7 1/2 IN. WIDTH 3/4 IN.

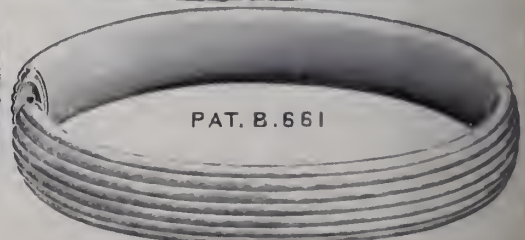

PAT. B. 661

SOLD DIRECT TO THE RETAIL TRADE ONLY

FEATURES OF OUR LINE

The UNIQUE, ARTISTIC and UNUSUAL, together with BEST WORKMANSHIP, SUPERIOR QUALITY and PERFECTION IN FINISH



Brooches in gold filled or sterling silver, the gold filled finished in rose or dark green ('antique'). The sterling in French grey or oxidized. We use finest imitation stones and can furnish any stone or color required.

We Manufacture in GOLD FILLED and STERLING SILVER

BROOCHES, HAT PINS, COMBS, HANDY PINS, WAIST PIN SETS, BARRETTES, SCARF PINS, VEIL PINS, LINKS, BUCKLES, SASH BROOCHES, BRACELETS and NECKLACES.

C. RAY RANDALL & CO., North Attleboro, Mass.

NEW YORK OFFICE, No. 7 Maiden Lane

SAN FRANCISCO OFFICE, Henry M. Abrams Co., No. 717 Market Street

Address all orders and communications to Factory, North Attleboro, Mass.



WE show herewith a new style bag—an exceptionally strong, stylish, snappy article.

Our new Spring line is complete—covering the entire range of bags—all shapes, all the different styles of mesh—the largest assortment of frames ever shown. Every piece stamped. W. & D. an absolute guarantee of satisfaction.

Your Jobber has them.

WHITING & DAVIS
PLAINVILLE (Norfolk Co.), MASS.

New York Office, 7 Maiden Lane



2/3 SIZE



The Original **Carmen Adjustable Bracelet**

With 20 years' experience and the best factory equipment that can be procured, we are able to produce

THE BEST IN THE WORLD FOR THE MONEY

The stamp, "The D. F. B. Co.," is a guarantee of quality and up-to-date designs. Ladies' and Gentlemen's Chains, Fobs, Lorgnettes, La Vallieres, Hat Pins, Chatelaine Pins and Bracelets.

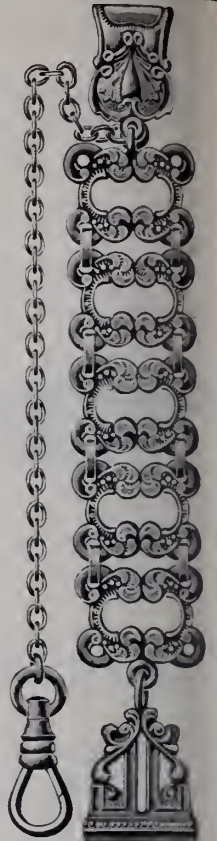

THE D. F. BRIGGS COMPANY

ATTLEBORO, MASS.

NEW YORK OFFICE
180 Broadway

CHICAGO OFFICE
Heyworth Bldg.

ST. LOUIS OFFICE
Mermod & Jaccard Bldg.

LONDON OFFICE
118-122 Holborn E. C.

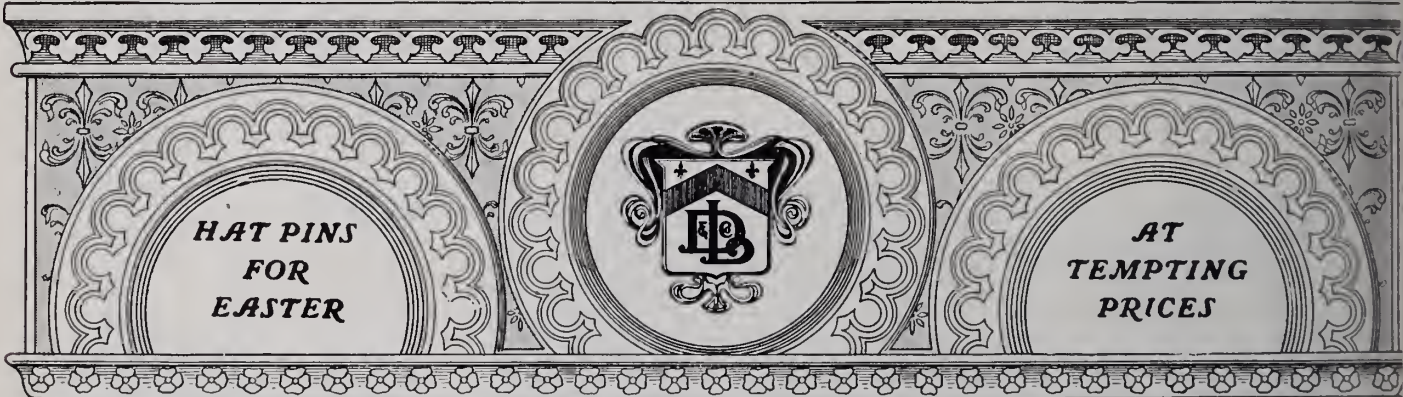

GIFTS will be bestowed this coming Easter as usual, but purchasers will be cautious as to the amounts they are willing to spend. This special line of Easter Hat Pins fits right in with prevailing conditions—combining appropriate colors and effects with very moderate prices. You can retail them profitably at from \$1.00 to \$3.00. There is business in them. AMETHYST, TOPAZ, LAPIS LAZULI, etc.

D. Lisner & Co. *Creating Importers of* **Jewelry Novelties**
One-Forty Fifth Avenue, cor. 19th St., NEW YORK



WE have noted quite an increased demand for Elk Jewelry, which is customary about this time, and throughout the Spring. Emblem goods are among the best "Sellers" the jeweler has and particularly so with the Benevolent Protective Order of Elk goods. Our assortment is larger than ever, many new patterns having been added, and you are welcome to selection package on request. We have a large number of extra fine charms suitable for Past Exalted Rulers and for presentation purposes generally.

An assortment of Elk emblems will help you to make sales, not only in Fraternal Jewelry but other articles, as all "Elks" are liberal buyers and good spenders. Write us any time about Elk Jewelry. We are headquarters.

HENRY FREUND & BRO.

Jewelry, Watches, Diamonds

71 NASSAU STREET, NEW YORK

The "Rose,"  our trade-mark, is a symbol of quality and excellence

Begin the New Year Right—Complete Your Stock with Right Goods

GOLD RINGS

Gold Scarf Pins

Gold Brooches

A Handsome Line of Seamless Wire GOLD FILLED RINGS

All ready for prompt delivery to the Jobber

OSTBY & BARTON CO.
PROVIDENCE, RHODE ISLAND

New York Office
9-13 MAIDEN LANE

Chicago Office
103 STATE STREET

The Best Selling "Thread" Pattern in the Trade



The SMITH "PILGRIM"

There never has been a more artistic and lasting design than the Smith "Pilgrim." It is characterized by simple elegance, refinement and dignity of design, and grateful absence of over-ornamentation. The Smith "Pilgrim" pattern will remain permanently in demand. Include "Pilgrim" in your stock. It is without question the best selling "thread" pattern in the trade to-day. Made in all the fancy pieces.

FRANK W. SMITH CO. MANUFACTURERS OF STERLING SILVERWARE Gardner, Mass.



TRADE MARK



MARGUERITE

MR. RETAILER:

That department in our factory called: "CREATION CORNER" is working overtime.

We simply won't stop creating.

It is just as natural for us to create

SNAPPY GOLD WATCH CASES, as it is for a "live wire" to spit sparks.

Some of our prettiest creations will blossom in April and any Jobber will gladly send you a few.



MARGUERITE

Solidarity Watch Case Company

Established 1885

54 Maiden Lane, New York

General Selling Agents:

JOHN W. SHERWOOD

::

::

FRANK E. HARMER

The KREMENTZ MATCH BOX

made expressly for paper matches, in 14-Kt. Gold and Sterling Silver, with the following finishes:
Roman, polished, engraved, engine turned and the Krementz gun metal finish.

Open



Side View
Closed



Order No. 1
in 14-Kt. Gold
2117

Front View
Closed



Order No. 2
in
Sterling
Silver
2043

The side and front views show its compactness. It opens and closes easily and fits the vest pocket, taking very little space.

KREMENTZ & CO.

Manufacturers of

Fine Gold and Enamel Diamond Jewelry in 14-Kt. Only

MADE EXCLUSIVELY FOR FINE RETAIL JEWELRY TRADE

BRANCH
San Francisco Office
722 Shreve Bldg.

Factory and Main Office
NEWARK, N. J.

BRANCH
New York Office
1 Maiden Lane

THE ELEMENT OF CHARACTER IN FOBS



THE FOB, in its history and associations, is related to the signet ring. Both were the stamp and impress, the mark and signature of their owner. Great pains were taken to give them character. Durand Fobs are true to their traditional character.

PRICES: \$10.00 to \$220.00



DURAND & CO.

49-51 FRANKLIN STREET
NEWARK, N. J.



OSMUN-PARKER MFG. CO.

MAKERS OF

Fine Pearl and Diamond Goods

338 Mulberry Street

NEWARK, N. J.

ENOS RICHARDSON & Co.

MANUFACTURERS OF

14-K GOLD JEWELRY



- HANDY PINS
 - TIE CLASPS
 - SAFETY PINS
 - VEIL PINS
 - BROOCHES
 - HAT PINS
 - FLAT LINKS
 - SCARF PINS
 - DUMB-BELL LINKS
 - BARRETTES
 - FOBS
 - BELT PINS
- 10-K AND 14-K NECK CHAINS AND GUARD CHAINS
- PLAIN AND JEWELLED LORGNETTE CHAINS

23 MAIDEN LANE, NEW YORK



The R. S. Cigar Cutter

In Sterling Silver, Plain and Engraved; and 14 k. Gold, Plain and Engraved, also Set with Diamonds.

A Novelty

Unlike all other cigar cutters, this one lies flat in the pocket—does not get out of order.

A Good Article



We Push It

Our advertising makes the customer want it; his friend sees it and he wants it. An endless chain of customers.

A Good Seller



Trade supplied by

Enos Richardson & Co.

23 Maiden Lane, New York.

☞ The Art of Reproduction of Jewelry.

☞ How many real illustrations have you seen of real nice jewelry? Very few!

☞ The jewelry art has been most unmercifully butchered, in the reproduction of the subjects, by photo-engraving houses, who profess to be able to do first-class work.

☞ And again, it sometimes is the fault of the customer to woe who thinks that the cheaper half-crown or plate will fill the bill—a fatal error.

☞ Turn this leaf, kind reader, and see if we have "lifted" the photo-engraving art or not.

☞ We believe we have, judging from the numerous complimentary letters we are receiving from new customers on our previous examples shown in this journal.

☞ If you have something that you desire to show to your trade either in the true colors of the original or in black or white, let us do it for you—and do it right.



THE COMPANY
JEWELRY PHOTO-ENGRAVING
NEW YORK

JEWELRY PHOTO-ENGRAVING COMPANY
NEW YORK

A most difficult subject, successfully treated by our improved
Direct Three-Color Process

See previous page



Made direct from
the goods

Plated and Engraved by the
Peninsular Engraving Company
Detroit, Mich.

G. R. HOWE
W. T. CARTER
W. T. GOUGH

ESTABLISHED 1841 BY A. CARTER

F. R. HORTON
F. W. STANBROUGH
H. L. FARROW

CARTER, HOWE & CO.

MANUFACTURERS OF

GOLD JEWELRY



Bags and Purses in Gold and Silver

9-11-13 Maiden Lane, New York

Factory, Newark, New Jersey

THEBERATH & CO., Inc.

Manufacturers of unusual, exclusive and salable designs in 14k. gold

**Brooches, Festoons, Handy Pins,
Barrettes, Pendants, Veil Pins,**

in beautiful plain patterns, or set with precious and semi-precious stones.

KENT & WOODLAND, SELLING AGENTS

12 John Street,

NEW YORK CITY

New Cigar Cutter

LOOKS AND WORKS LIKE A CHARM

This is the only practical cigar cutter that is a piece of jewelry for fob or chain. Can be set with diamonds and will admit of full size monogram engraving.

Patented and manufactured in 14K Gold by

Kollmar, Rauch & Co.

306 Market Street, Newark, N. J.

Sleeve Buttons
Fobs
Barrettes



Brooches
Scarf Pins
Handy Pins



We Protect You

which is absolutely a thing to be considered since the new Stamping Law has taken effect.

Bear in mind every article bearing our trade-mark is absolutely 10 K. and of highest grade of workmanship and finish.

THE KELLER JEWELRY MFG. CO.

Manufacturers of Fine Gold Jewelry

Brooches, Link Buttons, Lockets, Scarf Pins, Baby Pins, Handy Pins, Waist Sets, Crosses, Combs, Fobs, Tie Clasps, Charms, Lorgnette Chains, Neck Chains

64 NASSAU STREET, NEW YORK

Factory, 8 Lum Street,

NEWARK, N. J.



SOLID GOLD COMBS

From \$1.50 Upward

A Snappy New Spring Line

in Plain and Engraved Bands, also

New Effects in Pierced Tops

14k.—Everything in Gold Jewelry—10k. Brooches, Barrettes, Buckles, Bracelets, Pendants, Festoons, Emblems, Hat Pins, Fobs, Scarfs, etc.



2 Maiden Lane,

New York

I. N. LEVINSON, President

ESTABLISHED 1865

H. S. MORRIS, Sec. and Treas.

S. COTTLE COMPANY

Makers of High-Grade Gold and Silver Novelties

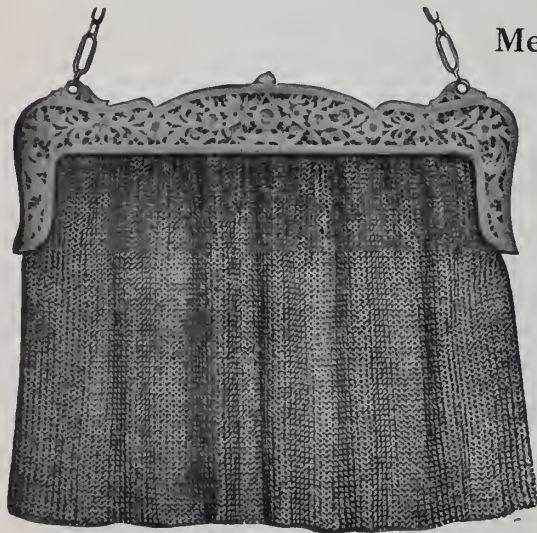

Mesh Bags Buckles

Card Cases

Vanity Cases

Purses Chatelaines

Our new line for Spring is now ready for inspection. Many new and artistic designs are shown. We wish to thank our many patrons for their past favors and hope for a continuance in the future.

31 EAST 17th STREET, NEW YORK

PARIS, 28 Rue D'Hauteville

FRANKFURT a M., Hanse-Haus, 9 Stifftstrasse

TRADE



MARK.

SNOW & WESTCOTT

21 MAIDEN LANE, NEW YORK

JAMES P. SNOW

CHAS. E. WESTCOTT

Makers of Fine Gold Jewelry

ESTABLISHED 1834



Monograms

INITIALS AND FOBS

Our Specialties

Write for Catalogue Prices and Discounts

CHICAGO ART METAL WORKS

63 Lake Street CHICAGO, ILL.

New England Watch Repairing for the Trade

GEO. W. HYDE & CO.
101 TREMONT STREET
BOSTON, MASSACHUSETTS

Make a Specialty of Repairing New England Watches

Work returned in one week, and guaranteed to be satisfactory in every respect. Recommended by The New England Watch Co.

Day, Clark & Co.

Makers of 14-Kt. Jewelry

23 Maiden Lane
NEW YORK



BUY GOODS WITH A TRADE-MARK

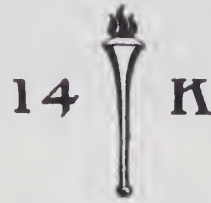

BANGLES
BROOCHES
BANGLE BRACELETS

HANDY PINS
TIE HOLDERS
VEIL PINS

A General Line of Fine Jewelry

BIPPART, GRISCOM & OSBORN

OFFICE AND FACTORY
Newark, N. J.

NEW YORK SALESROOM
1 West 34th St.

Grace for the Graceful

YOU WANT what your customers want—and every woman wants a Necklace. You want this Gold Bead line. Even and Graduated. Perfection of Vermicelli trim. Finest of Roman finish. Plain and decorated alternations. Fifteen sizes. It pays to carry them.

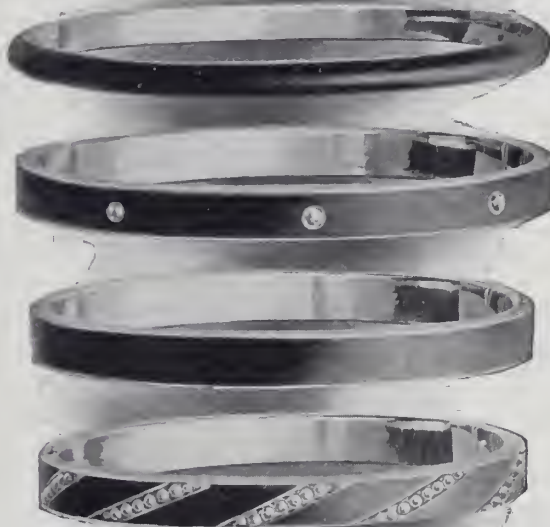

Mourning Goods
of all kinds

Bracelets
Brooches
Scarf Pins
Buttons
Studs
Necklaces

Everything in Black

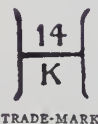

TRADE-MARK

A. J. HEDGES & CO.

Makers of 14K. Jewelry

14 John St., NEW YORK



SEED-PEARL NECKLACES IN ALL SIZES.

OSMERS-DOUGHERTY CO.
MANUFACTURING JEWELERS

291-293 SEVENTH AVE., NEW YORK
Bet. 26th and 27th Sts. Telephone, 913 Madison.

DEALERS IN
BAROQUES, PEARLS and
FANCY STONES



DESIGNING
AND
SPECIAL ORDER WORK

LOCKETS

All parts of our Lockets are strictly 10 K. The patterns, workmanship and finish are in keeping with our latest productions in up-to-date 10 K. jewelry.



LOCKETS

- Round
- Heart Shape
- Square
- Oval
- Plain
- Fancy
- Emblematic
- Hand Engraved
- Set with Diamonds
- Set with Cameos

Schultz & Co.
Makers of "Business Builders"



Factory and Office
91 Oliver Street - - - Newark, N. J.
New York Salesroom
12-14 John Street - - New York City

After July 1, 1908, this Company will change its name to
Percy M. Layman **LAYMAN & STRAUS CO.** Sydney C. Straus

"THE BRACELET HOUSE"

GOLD BRACELETS of every kind
For WOMAN, MISS OR BABY

KENT & WOODLAND

16 John Street, New York

Factory: Newark, N. J. San Francisco: Julius A. Young

DIAMOND MOUNTINGS

of any description in gold and platina

Order Work a Specialty

HENRY BASCHKOPF

47-49 Maiden Lane

New York, N. Y.

1. Snap complete.
2. Outside of snap.
3. Inside of snap.

**The E. P. H. Patent
NON-PULL-OUT
Neck Chain Snap**

*is a patented snap that insures
the wearer against loss of*

CHAIN or CHARM
for it positively will not pull out

Made In 10 and 14 Karat Gold and
In Gold Filled.

Can be had of the following Wholesale
Selling Agents:

- Messrs. W. Green & Co.,
81 Nassau St., New York
- M. Sickles & Sons, Philadelphia
 - E. A. Cowan & Co., Boston
 - E. & J. Swigart, Cincinnati
 - Swartchild & Co., Chicago
 - Nordman Brothers, San Francisco
 - Leonard Krower, New Orleans
 - A. Walker Co., Providence, R. I.
 - Bauman-Massa Jewelry Co., St. Louis
 - H. S. Melskey Co., Lancaster, Pa.
 - The Edw. Lehman Jewelry Co., Denver, Col.

PRICES.

- 14 Karat—Small, \$7 per doz. net
- Large, \$7.50 per doz. net
- 10 Karat—Small, \$6 per doz. net
- Large, \$6.50 per doz. net
- Gold Filled—Small, \$2 per doz. net
- Large, \$2.25 per doz. net

**THE GREAT AMERICAN
JEWELRY CATALOG**

Is a publication of real practical value; it truthfully illustrates those lines of merchandise; best adapted to the needs of the *Jewelry Trade*; it's reliability is unquestionable.

SAFETY

With implicit confidence you can use it when ordering goods; it insures you against deception; remember, for every dollar's worth of merchandise you buy you are obtaining positive, intrinsic value.

Write for this catalog; it means much to you.

THE OSKAMP-NOLTING CO.

Mammoth Wholesale Jewelers
411-413-415-417 Elm St., CINCINNATI, OHIO

UNIQUE GEMS

SEMI-PRECIOUS CEYLON, URAL and NATIVE
GEMS My Specialty
Prices the Lowest. Sample Papers sent on Request
to Reliable Jewelers and Manufacturers.

Louis J. Deacon, Atlantic City, N. J.

The "Bryant" Rings.

WE have made the **Bryant Rings** for 50 years, and know how to make first class goods. The stone setting—which every retailer knows is a very important part of the work—we give special attention to. The **Bryant Rings** will help your reputation as a first class Jeweler.



M. B. BRYANT & CO., No. 7 MAIDEN LANE,
NEW YORK.



SOLID GOLD CHAINS

bearing our trade mark stand for the highest achievement in gold chain manufacture. Plump quality, perfect workmanship, careful finish and attractive designs—all combined—distinguish our product.

WE SELL DIRECT TO YOU

No intermediaries, no corps of salesmen, no unnecessary expenses to add to the price—just the cost of the gold, the cost of making and a modest profit for ourselves enable you to buy the best chains at the lowest price. SEND FOR CATALOGUE.

ALOIS KOHN & CO.

16-18 MAIDEN LANE, NEW YORK

Gold Chains of Every Description

The Bowden Rings

ARE COMPLETE IN VARIETY, CORRECT IN QUALITY AND PERFECT IN FINISH. WE MAKE EVERY VARIETY OF FINGER RINGS.

J. B. BOWDEN & CO.,

1 Maiden Lane,

NEW YORK.



CAMEOS

Stone, Shell, Coral and Lava.
Rolled Gold Plate Mountings

SELECTIONS SENT TO
RELIABLE JOBBERS

Maintien Brothers & Elliot
North Attleboro, Mass.

"If It Is Chopard's Idea, It's Ideal"

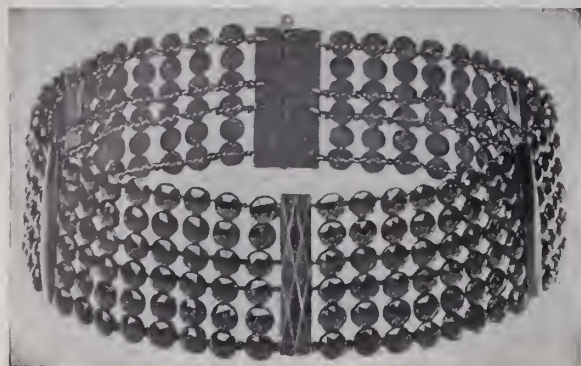

JETS continue to occupy the "Center of the Stage," and no matter what you want, we can supply it.

Also White Stone and Novelty Jewelry of every description, and Fish Skin Pearls of unequalled lustre; all grades.

As we have said before, everything, direct from Paris, through us to you, at prices that insure you **BIG PROFIT** on **SMALL INVESTMENT**.

Selection Packages Sent Upon Request.

CHOPARD FRÈRES

Factory, 35 Rue des Trois Bornes,
PARIS, FRANCE

NEW YORK, OFFICE
56 Maiden Lane

S. F. Myers & Co.

WHOLESALE JEWELERS
47-49 Maiden Lane
New York

To do the best that is known to-day, and seek for the better to-morrow—that is our way.

For the trade only—our new, big catalogue, with 100,000 items, sent free.

GARREAU & GRISER
68 & 70 Nassau St., New York
LAPIDARIES. PRECIOUS STONES
GEMS in Unique Cuttings



327

FINE

Diamond Mountings
ALSO
Bracelets
AND
Dwt. Goods

S. PITZELE

Established 1893

51-53 Maiden Lane NEW YORK

Manufacture of



306



688

SPECIAL
ATTENTION
GIVEN
TO ORDER
WORK



325



329



218



435



348

Perennially Popular

THE best evidence of the popularity of our various lines is the increasing demand for them and our consequent growth. Our jewelry is unexcelled in every quality that contributes to serviceability and appearance. The designs are artistic enough to court that investigation which results in sales.



No. 1117

Ask to see our line of

**CHAINS
CHAIN PENDANTS
CROSSES
AND BRACELETS**

The

Kenilworth Bracelet

particularly, the strongest on the market.

**DORAN,
BAGNALL & CO.**

North Attleboro, Mass.

OFFICES

New York: 194 Broadway.
Chicago: 42 E. Madison St.
San Francisco: 91 Drumm St.

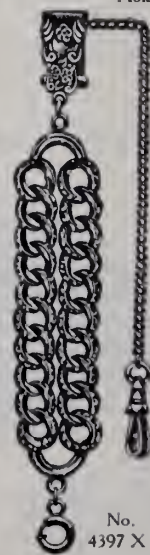

No. 4397 X 1

Send for the Latest Styles in
MONOGRAMS AND INITIALS

as manufactured by

THOMAS J. DUNN CO.

101 Chambers St., New York

Makers of exclusive styles in

MONOGRAM FOBS

in Gold, Sterling and Rolled Gold Plate. Our 1908 Ladies' Belt Buckles are most original and artistic.

Specialties in the Monogram and Initial line.

Send for Illustrated Sheets.



Orders Prove Our Goods Sell

Q We make for the Jobbing Trade the following lines of Solid Gold Jewelry:

Rings, Scarf Pins, Studs, Brooches, Charms, Baby Pins, Handy Pins, Chain Sets, Link Buttons, Hair Barrettes, Crosses, Ear Screws, Pierceless Drops, Cameos in all styles, etc.

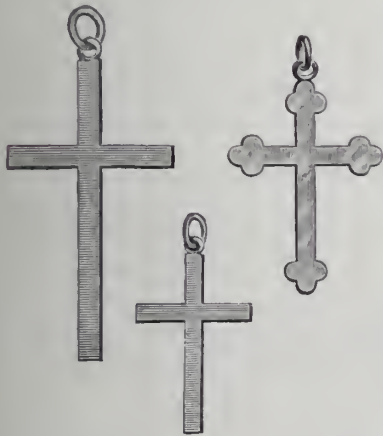

Insist upon seeing the designs of Gold Jewelry made by the

E. L. Spencer Company

95 CHESTNUT STREET
PROVIDENCE, R. I.

NEW YORK OFFICE
9-11-13 MAIDEN LANE

(SAMPLES ONLY)

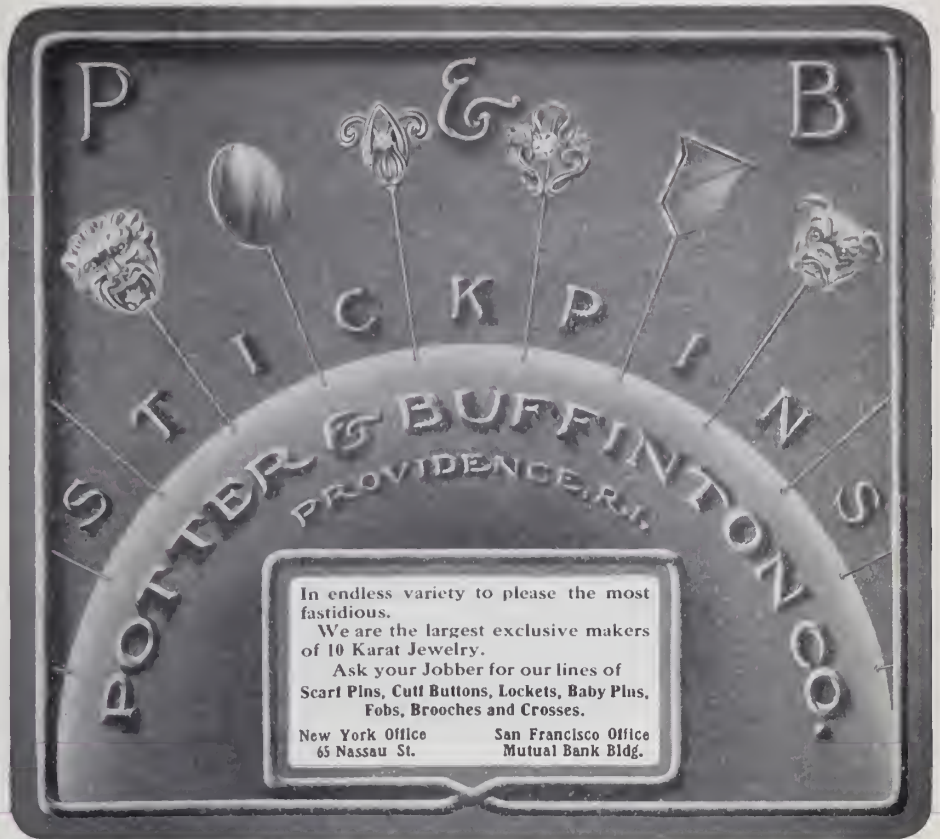

In endless variety to please the most fastidious.

We are the largest exclusive makers of 10 Karat Jewelry.

Ask your Jobber for our lines of Scarf Pins, Cuff Buttons, Locketts, Baby Pins, Fobs, Brooches and Crosses.

New York Office
65 Nassau St.

San Francisco Office
Mutual Bank Bldg.

Important Notice

The jewelry trade is hereby notified that the following manufacturing jewelers have been granted licenses under my pending patents to manufacture and sell the "Fashion" Collar Pins:

KREMENTZ & CO.
CARTER, HOWE & CO.
BIPPART, GRISCOM & OSBORN
A. J. HEDGES & CO.
ECKFELDT & ACKLEY
J. T. MAURAN MFG. CO.
WOLCOTT MFG. CO.
ARCH CROWN MFG. CO.
SCHRADER-WITTSTEIN CO.

The trade is informed that I shall protect our rights under my pending patents to the full extent of the law, and having confidence in the fairness of the trade in general, I believe that I may expect its co-operation by refusal to purchase should other manufacturers than those above mentioned offer "Fashion" Collar Pins in imitation of mine.

Thanking the trade in advance for its consideration, I beg to remain, very respectfully,

CHARLES T. WITTSTEIN,
ARCH CROWN MFG. CO. Camp and Orchard Sts., Newark, N. J.

LOCKETS ONLY

Registered



U. S. Pat. Office



Pat. Applied for
NUMBER
8482

Latest Design Appropriate for Easter

WIGHTMAN & HOUGH CO.

NEW YORK OFFICE
3 Maiden Lane

Main Office and Factory } 7 Beverly St.
PROVIDENCE, R. I.

Pierceless Ear Screws

We are making a complete line of these popular goods. Samples upon request.

Also a new line of

- Brooches
- Scarf Pins
- Baby Pins
- Links
- Studs
- Crosses
- Ear Rings
- Rings
- Neck Chains

We have manufactured Gold jewelry for over fifty years and our goods have stood the test of time.

DON'T NEGLECT TO
SEE OUR LINE.

Wm. C. Greene Co.

Established 1849 Incorporated 1906

MANUFACTURERS OF
GOLD JEWELRY

101 Sabin Street,
Providence, R. I.

"HOLD-ON" CLUTCH



FOR SCARF PINS AND BROOCHES

14K. GOLD PLATE
SUPERIOR TO ALL OTHERS

PRICE 50 CENTS

Pat. May 20, '02
To Release
Pull the Ball

Pat. May 20, '02
Attached
to Scarf Pin

ADVANTAGES:

1. *It Holds* — The harder you pull, the tighter it holds.
2. *To Release* — Raise the clutch and pull the ball.
3. *All One Piece* — No parts to lose.

HOLD-ON CLUTCH CO. 33 GOLD STREET NEW YORK

Don't Worry About the Scarcity of Money

If you need any send us your surplus stock of Diamonds, Watches, Jewelry, Old Gold and Silver, and get our certified check by return mail. If amount is not satisfactory goods will be returned in same condition as received. Strictly confidential. Correspond or call. Telephone, 5202 John.

New York Jewelry Purchasing Co.
106 Fulton Street, New York

O. M. DRAPER CHAINS

ALL KINDS OF VEST CHAINS
PRINCESS, NECK AND GUARD CHAINS

We do not make as much noise as some of our friends but we are "there with the goods" and the *Jobbing Trade* handling our product for the last half century, know that our QUALITIES are genuine and can be depended upon, that our FINISH is unparalleled and that our prices are consistent.

If you do not handle O. M. DRAPER GOODS, we both lose.
We sell only to the Jobbing Trade.

Estate of O. M. DRAPER

Factory, No. Attleboro, Mass.

NEW YORK OFFICE
37 Maiden Lane

SAN FRANCISCO
506 Chronicle Building

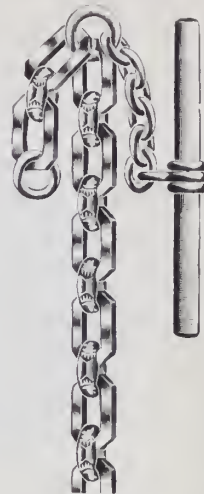
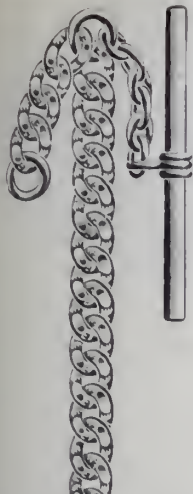

Workshop Notes for Jewelers and Watchmakers

Cloth :: Postpaid, \$2.50

Published by
The Jewelers' Circular Pub. Co.
11 John St., New York

THE CROWN PATENT SAFETY GUARD



For Scarf Pins and Lace Pins. The most adjustable one invented. Price, \$1.50 per doz. For sale by all wholesale jewelers and material houses. Sample by mail, 25c.; in 10k. gold, \$1.00; 14k., \$1.25. M. CROHN, Maker and Inventor, 48 and 50 Maiden Lane, N. Y.



A MILLION RINGS ARE NOW worn that are loose on the finger and need Wells Perfect Ring Adjusters to hold them in place. Why not fit these and make a good profit and new customers.

Ask your Jobber for them Sold in 1 doz. assorted sizes in packages as follows: 10 K. Gold, \$3.75; Gold Filled, \$2.00; Metal, 85 cents.

CHESTER H. WELLS, Jeweler, Meshoppen, Pa.



Roller Chain

OUR SPECIALTY

Do not forget that we still continue to show the best line of these goods on the market, in Fobs, Bracelets and Neck Chains. These wear longer, give better satisfaction than any metal fob made, and our designs are up-to-date. Also our line of chains of all kinds find a ready market among the best trade, both in 1-10 and a medium wearing grade.

We also make a nice line of Brooches, Hatpins, Scarfpins, Barrettes, etc., that should demand your attention.

Ask your jobber, and if unable to obtain them from him, advise us who he is, and we will make arrangements for you to get them.

B. S. FREEMAN CO.

ATTLEBORO FALLS, MASS.

Chicago Office, J. T. Edwards, 103 State St., Chicago, Ill.

NECKLACE No. 540



Lapis, Amethyst, Quartz, Spanish Topaz Amazonite.

Price, \$4.50

Illustration half size

Hand Made Sterling Silver Real Stones

INNUMERABLE DESIGNS

CORAL CAMEOS—NECKLACES

BELT PIN or BUCKLE No. 884



Lapis, Amazonite, Spanish Topaz, Amethyst. Price, \$4.00

VAN DUSEN & STOKES CO.

1123 Chestnut Street, PHILADELPHIA, PA.



EASTER OFFERING

THE INTEREST we take in our **VERIBEST LOCKETS**

does not end when we receive
your money.
Our Lifetime Guarantee
Is practically without time limit
And both assures and protects.

IT MEANS

that the purchaser of a

Lederermak



Labeled Inside

Is certain that the locket will be
mechanically perfect and give
absolute satisfaction as good as gold.

Exclusively sold by **VERIBEST** Jobbers Everywhere

S. & B. L. ★ CO.

Famous Since 1870

New York City
9-11-13 Maiden Lane

Providence, R. I.
100 Stewart Street

Chicago, Ill.
131 Wabash Avenue

EVERYTHING IN LOCKETS AND CHAINS.

THE BASSETT JEWELRY CO.,

PROVIDENCE, R. I.

Roger Williams Silver Co.,
PROVIDENCE, R. I.

Sterling Only.

RICH DESIGNS :: :: :: Photos. on Application.

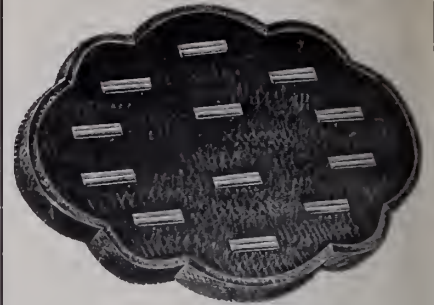

SCALLOPED—Suitable for 12 Rings

WE MANUFACTURE

Fancy Platforms and Blocks for
Window Display.

Trays for Show Cases and Travel-
ers' Use of every description.

Jewelry Boxes in many qualities
and styles.

Boxes for Silverware, Manicure
and Toilet Sets.

Silverware Chests in any
combination.

Flannel Rolls and Bags for Silver-
ware.

We Re-cover Window Platforms
and Trays.

PAPER BOXES.

Tags, Cards, Cotton, Findings, Etc
Estimates and Samples Cheerfully Furnished

WOLFSHEIM & SACHS

Office and Salesroom: 35 Maiden Lane, New York
(Lorsch Building)

Factory: 10 Gold Street, N. Y.

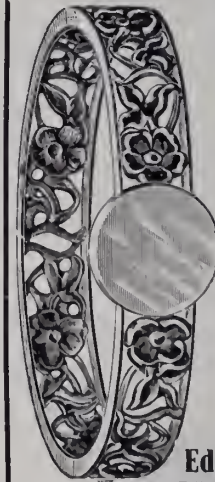

10K. GOLD BRACELETS

New and Original
—Designs in—

**BANGLE, JOINT
—AND—
CATCH SIZES**

Scarf Pins, Ladies' Rings
Earrings and Handy Pins

In a great variety
of designs

TRADE MARK

**THE
Edwin Lowe & Co., Inc.**
F.W. BODWELL, Pres. & Gen. Mgr.

116 Chestnut St., PROVIDENCE, R. I.
New York Representative: E. T. Wilson, 180 Bway.
Western Representative: S. H. Brower

Learn Watchmaking

Refined, profitable labor. Competent men always
in demand. We teach it thoroughly in as many
months as it formerly took years. Does away
with tedious apprenticeship. Money earned while
studying. Positions secured. Easy terms. Send
for catalogue. Address

St. Louis Watchmaking School, St. Louis, Mo.

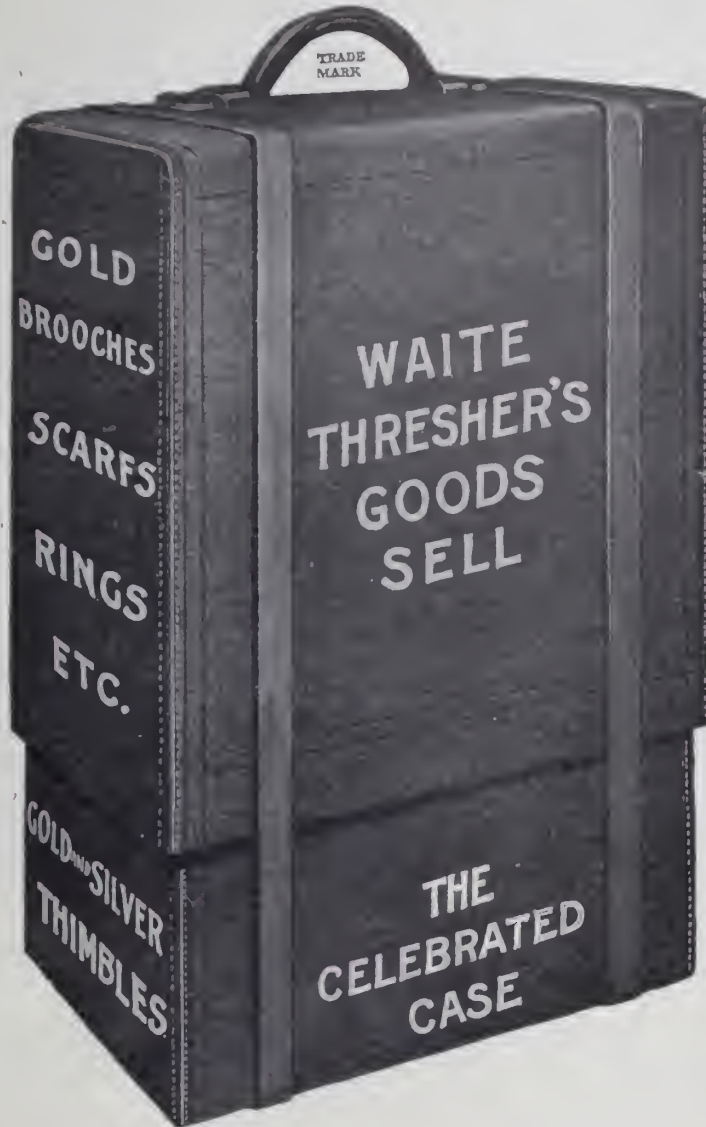

DIES

We are continually preparing new designs for jewelry, silverware, medals, emblems, brass goods, etc. Over 300 satisfied customers are our best recommendation.

Write us and tell us your needs. Let us submit a selection of designs subject to your approval.

Crees & Court

DIE SINKERS

21 Eddy Street PROVIDENCE, R. I.



It's the Little Things that count.

The dainty little things that appeal at once to the casual observer. If it's useful, as well as ornamental, so much the better. Here is a LITTLE THING, so very useful and so pretty in design and finish, that you have but to show one to make a sale, and it yields a BIG PROFIT. It is called

The Automatic Eye-Glass Holder

Can be used as well for a Pencil Holder. It is made in Enamel, Gold, Silver and Rolled Plate, in a variety of artistic designs. We fully guarantee every Holder. We mean it, and will replace any Holder that fails to satisfy. Samples sent upon request. Send for catalogue.

Est. 1832. **Ketcham & McDougall, Manufacturers,**

37-39 MAIDEN LANE, NEW YORK.

ALSO MAKERS OF THE LEADING LINE OF THIMBLES.



THE CHAS. M. ROBBINS CO.
 MANUFACTURING JEWELERS AT TLEBORO. MASS

The Scarab or Sacred Beetle

WROUGHT in cloisonne enamel with beautiful transparent and iridescent colors. Made in *Belt pins, Brooch pins, Hat pins, Stick pins, Cuff links or Watch fobs.* Prices from \$3.00 to \$36.00 per dozen.

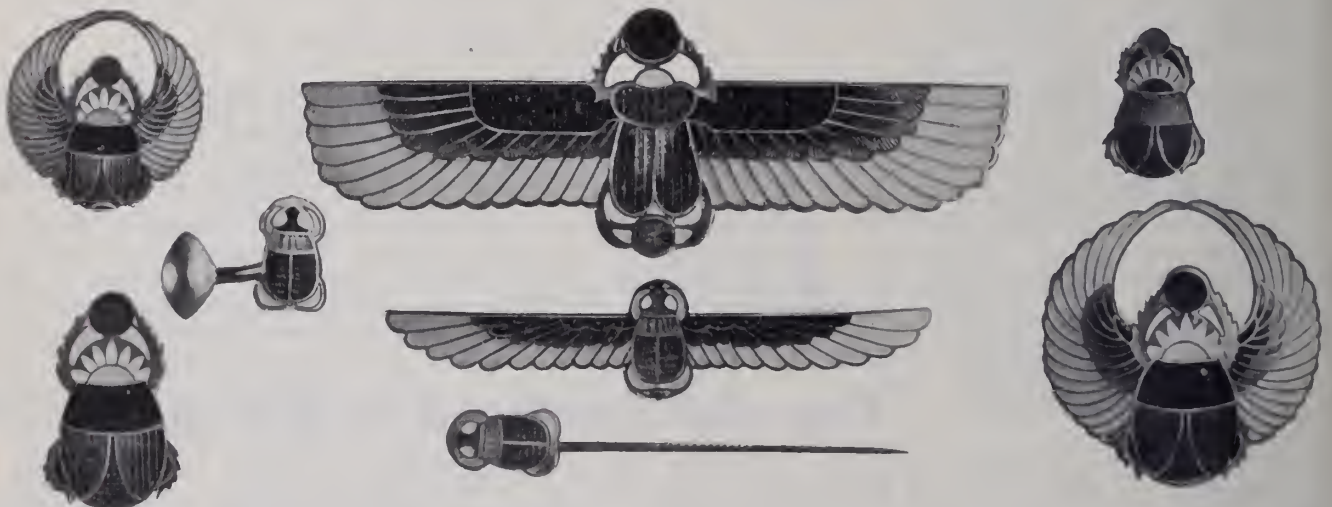

This most ancient Egyptian symbol of good fortune is the best novelty of the season. Samples sent on approval.

The Shepard Manufacturing Co., Silversmiths, MELROSE HIGHLANDS, MASS.



The Gillette Safety Razor Set consists of a triple silver-plated holder and twelve double edged, thin, flexible, wafer-like blades (24 keen edges), packed in a velvet lined leather case. Price, \$5.00. Also made in Combination Sets in a variety of styles with toilet accessories retailing from \$6.50 to \$50.00 each.

Would You Have the Present Year Bring You Increased Patronage, Profit and Prosperity?

Do you realize that nearly every hour in the day some man is converted to the easier, quicker and more economical way of shaving himself with the

Gillette Safety Razor?

Our persistent and vigorous advertising in the leading publications of this country discloses — *and will continue to disclose* — beyond all question of doubt, the superiority of the "Gillette." It advocates the advantages of self-shaving and guides the man to your store with a five dollar bill to exchange for the best shaving device in this world.

You can readily see the wisdom of having the "Gillette" ready when he calls. The Standard Gillette Set retails at \$5.00 everywhere. Combination Sets from \$6.50 to \$50.00. Keep a good supply in stock. Write to-day for valuable selling information and prices.

GILLETTE SALES CO., 904 Times Bldg., New York City



Locket 2985—Old English



Bracelet with Joint
915—O. E., Engraved, Stones set as ordered, 2 3/4"
916— " " " " " " 2 1/2"
917— " " " " " " 2 3/4"



3863—Rose, Red Eyes, White Mouth
3862—Rose, no stone



3899—Rose, Red Eyes, White Mouth
3898—No stone



3842 Rose, set as ordered
3900 O. E. Set as ordered

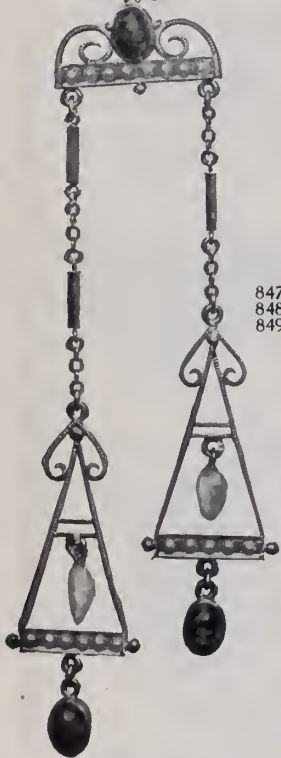
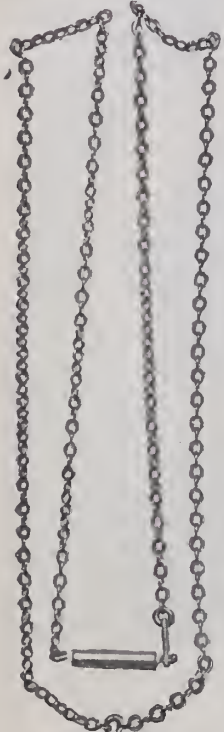

Neck Chain 294—16" long
Old English Chain
Roman Scrolls
Baroque Pearls and Japanese Jades



2978—Roman and Green Pearls and Brilliant
2977—No stone



Hat Pin
847—Rom. Red Enam.
848— " Blue "
849— " Green "



Belt Buckle
3542—Rose, set as ordered
3543—Green, "
3544—Sterling Grey, set as ordered



851—Rose, Real Malachite Stone
852—Green, Real Malachite Stone



844—Rose or Green Stones set as ordered



Baby Pins
3869—Roman
3870—Old English
3871—Pearl Set, Roman
3872—Old English, Pearl Set



3005—Rose, no stone
3007— " Brilliant

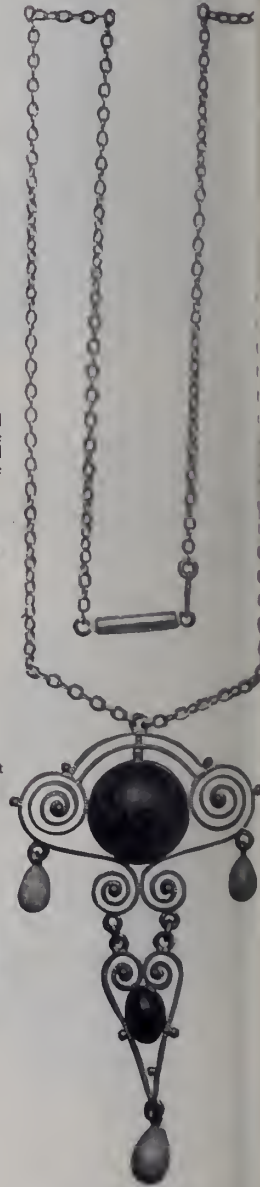

No. 298—16" Neck Chain O. E.
Roman Scrolls
Jap. Jade Stones, 3 Real Cornl Pendants

Do You Realize

that Spring is near at hand and with it the certain demand for Good Selling Jewelry?

We offer this Season an exceptional line of Fine Gold Filled Goods, among which are Neck Chains and Pendants, Locketts and Charms, Link Buttons and Bracelets, as well as Brooch, Veil, Scarf and Hat Pins.

Each design is skilfully executed and beautifully finished.

Our Sterling Silver Ware includes many new styles in Toilet and Manicure Goods, Vases, Candlesticks and Novelties.

Theodore W. Foster & Bro. Co.

Manufacturing Jewelers and Silversmiths

100 RICHMOND ST., PROVIDENCE, R. I.

NEW YORK 13 Maiden Lane

CHICAGO: Heyworth Bldg.

CANADA: Kingston, Ontario

Some Fine Examples of the Art of Munich Silversmiths.

MUNICH, that beautiful Bavarian city, where high art and beer dwell together in strange harmony, has by no means neglected any of the branches of industrial art, and among them that of the silversmith takes a prominent place. This is well



PRIZE PRESENTED BY BAVARIAN AUTOMOBILE CLUB TO VICTOR OF RACE AT MUNICH.

shown in the illustrations herewith of some interesting pieces which have recently issued from the prominent workshop of Ed. Wollenweber, court silversmith at Munich.

One of these creations, shown on the front cover, is a "nef." The use of the form of a ship as a table center at one time was very general, and of recent years has been revived again. These "nefs" form a most

picturesque table decoration at large banquets, etc. In the present piece the ship is 58 centimeters (23 inches) high, and was presented by the board of directors of a prominent steamship company to their manager on the occasion of the celebration of his jubilee.

The base is of bronze, while the waves, the hull of the vessel, sails, figures, etc., are of silver. On the prow is a genius with two juvenile figures, offering a laurel wreath to the celebrant. Aft on the vessel the coat-of-arms of the company in question is affixed, which is held by two figures. Everything, including the models, was executed in the shop of the aforesaid artist.

A very fine example of artistic silver-smithing is the mug shown in the cut at the right. This was made on an order from Berlin. The German eagle bears the medallion of the present Emperor William on the lid, which is richly chased. On the body appears the Imperial Castle at Berlin in artistic engraving, and above the castle the double eagle with an inscription band.

We have described in these columns various former prizes of the Herkomer automobile race, one of the leading sporting events in Germany. For the last Herkomer contest no prize was dedicated by the city of Munich, a fact which has caused much disappointment in automobilizing circles, but the Bavarian Automobile Club has had various valuable trophies for the victors of the race made in Munich. The most notable among them is the bowl illustrated on the left. This magnificent specimen rests upon a base of green marble and a pierced substructure in four divisions decorated with the enameled coats-of-arms of Germany, Bavaria and of the Imperial and the Bavarian Automobile clubs. These four coats-of-arms are united by green enameled hanging garlands. The whole lower structure is richly embellished with semi-precious stones. The bowl resting on this base has the usual kettle-like shape with the highly plastic ornaments in exquisite chasing. The protruding handles which run all around the bowl terminate into little laurel trees and winged wheels, the emblem of traffic, which are again organically combined into a frieze.

The pleasingly rounded lid is crowned with figures. A vigorously modeled man is seated upon a winged dragon and has seized the tamed monster by the comb or mane with the left hand, while he shields his eyes with the right, for he is peering far out upon the goal to which a female genius points with outstretched right arm. In the left hand the figure bears the palm branch of victory. The frieze encircling the

bowl and lid as well as the dragon are richly studded with colored semi-precious stones, whereby the effect of the unique piece is materially heightened.

The design for this striking bowl was furnished by the Munich art painter, F. H. Mederer, while the excellent execution bears eloquent testimony to the high development of the art of working precious metals in Munich. C. A. B.

Recent Decisions by General Appraisers on Jewelry and Kindred Lines.

Decisions of the Board of United States General Appraisers, New York, in cases involving duties on jewelry and kindred lines,



HANDSOME MUG MADE BY MUNICH SILVERSMITH.

have been announced in the last week as follows:

HAT-PINS, JEWELRY.—Protest of Stern Bros., New York. Hat-pins having gun-metal heads set with imitation diamonds were held to have been properly classified as jewelry under Par. 434, Tariff Act of 1897.

TOY NECKLACES, LONG CHAINS.—Protests of Blumenthal & Co. and protests of A. J. Hague & Co., et al., New York. The protests related to necklaces and long chains. Those valued at less than 11 marks per gross were held dutiable as toys under Par. 418, Tariff Act of 1897, as claimed by the importers. G. A. 6658 (T. D. 28391) followed.

JEWELRY.—Protests of G. W. Sheldon & Co., Chicago; protests of B. Altman & Co., and protest of A. L. Tuska, New York. The goods were held to have been properly classified as jewelry.

H. H. Nerbovig, Waseca, Minn., is selling his stock at auction, preparatory to retiring.



No. 278

The making of an article in 14k. gold, then duplicating the same thing in 14k. gold filled, presents two different propositions.

While it is generally known that we make the largest and best line of 14k. gold shirt studs in the world, do you know that we reproduce these same studs in 14k. gold filled, in a great variety of patterns at prices that ought to interest every retail jeweler?

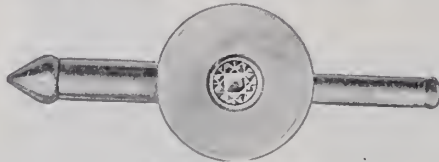

No. 270

These illustrations are from our line of Larter Shirt Studs in 14k. gold filled, and the studs themselves are just as attractive as the pictures.



No. 201

This line is to be had through progressive jobbers only.

LARTER & SONS

21-23 Maiden Lane, New York, N. Y.

TRADE-MARK



REGISTERED IN U. S. PATENT OFFICE



No. 3156

Every article of gold jewelry manufactured requires experience, and often clever ingenuity to produce it strong in construction, attractive in pattern and at the right price.

If you have not given our line of 14k. lockets careful consideration you ought to when the opportunity is next presented.

We make a complete line of plain round lockets, the largest line of engine turned lockets in the market and a choice selection of fancy lockets. The above illustration is one from the latter and is made in three sizes, with or without diamonds, for two pictures, at moderate prices.

Our travelers have them, or we will be pleased to send a selection to progressive jewelers.

LARTER & SONS

21-23 Maiden Lane, New York, N. Y.

TRADE-MARK



REGISTERED IN U. S. PATENT OFFICE

THE OCCULT IN GEMS AND JEWELRY.

By C. W. Coumbe.

(Continued from issue of Feb. 26.)

RING DIVINATION

WHILE to the ancients there are manifold methods of delving into the events of the future, perhaps none was so positively certain of the outcome as those of Dactylomania. To the ancients, in their never-ceasing hunt for wisdom, this was a most prolific branch of research.

In the engraving, Fig. 4, is reproduced the signet or seal of a divination ring. It is hieroglyphic; the bird-like form is a sphinx, the monster of bird's body and woman's face, which propounded riddles to passing mortals and destroyed those unable to solve them. Notice the cabalistic divination star over its head. The goblet is, of course, a divination cup, foretelling future events by crystal reflection. Near the cup are Pan's pines—music's charms—etc.

Unfortunately in the oral passage of the doctrines and ritual of dactylomania from age to age the dust of doubt and loss of detail mar the sequence and wholeness of the

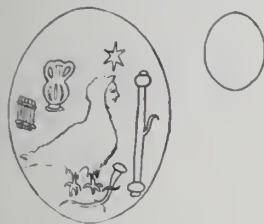

FIG. 4—DIVINATION RING.

practices so far as they have come down to us. But sufficient authentic information is yet available to gain a glimpse into the forms and ceremonies, and if in 20th century practice the divinations are not as satisfactory from an oracular standpoint as might be desired the rings used in the occult inquiry remain at least uninjured for the owner.

One of the simplest formulas for ring divination, and one which has probably on that account received most practical attention at the hands of a modern public is hydromancy carried on after the following manner:

A ring is suspended by a slender thread from the finger and allowed to dip into a bowl of water. Questions are put, and if the reply be yes, without any ulterior assistance, the ring will swing itself and hit the sides of the bowl a certain number of times.

MEDICINAL RINGS.

One of the many "lost arts"—one that no doubt by its absence holds back our medical fraternity most seriously—is the correct utilization of "medicinal" rings. In the inscribed signets of the illustrations of medicinal rings (Fig 5) accompanying this, the rough, old-style lettering invoking "renewed health" and "increase of days" do not inspire 20th century sceptics with faith in their potentialities.

Trallian, a largely gifted physician of the fourth century, was a specialist on colic and

biliary complaints. And his sovereign cure consisted of an octangular ring of iron. There were eight words engraved on this, and they commanded the bile to "take possession of a lark" (from which you can see what a commanding position he held). There was also a magic diagram which had to be added to carry out the cure efficiently.

This able physician left other invaluable prescriptions behind when he followed in the straight path of his patients. A copper ring is one, with the figure of a lion, a crescent and a star. This is to be worn



FIG. 5—PHYSICIAN'S MEDICINAL RING.

on the fourth finger. Another powerful remedy of his for ordinary cases of colic was in the application of a ring with an engraved Hercules strangling the Nemoean lion.

Galen (about 200 A. D.), the world renowned therapist and doctor, tells of a green jasper amulet of King Nechepsus, of Egypt (630 B. C.) that had cut in it a design of a dragon surrounded by rays. This potent remedial agent aided the digestive organs of its wearer remarkably.

The Leipzig physician, Michaelis, cured any old disease that came along. But he had a most marvelous ring to bring about these effects. It was made from the tooth of a sea horse. 'Tis a pity sea horses' teeth are still so scarce!

A capital relief for headaches was obtained through rings of lead mixed with quicksilver.

But at the present day the inhabitants of Devonshire (England) forfend the enchant-



FIG. 6—RING OF MAGI. FIG. 7—MYSTICAL RING.

ments of evil spirits with rings of cheap manufacture through uncanny material. They prefer rings made of nails from coffins dug out of the churchyards.

That the jeweler would be safe in recommending certain precious stones to his customers who are on the sick list is shown from many facts.

Pliny says the emerald jasper was a great favorite with the Orientals as an infallible panacea for each and every ill; but the full power of that stone was only attained in a silver, not a golden, circlet. But the limit of power of precious stones to aid humanity's woes does not end with cures for the sick. They protect the wearer against the "evil eye" and demoniac influences of all kinds. Turquoises reconcile man and wife. Carbuncles drive away "poisonous air" (useful for ladies in street cars where to-

bacco fumes stray), they "repress luxury and preserve health."

BIBLICAL MYSTIC RINGS.

Great powers were said to lie in the ring worn by the Jewish high priest, giving him great celestial power. The ring of Solomon enabled him to baffle his enemies.

Many of the mystics used the names of the three "Wise Men," the Magi, in their devotional exercises, and there are still extant "rings of the Magi" which were said to bring to their owners superhuman powers. One of these is illustrated here. Some recent writers on the subject trace in the name of the first of this triad the Jasper—stone of mystic power.

Another of the sacred rings is also here depicted. The circlet is adorned all around it with double concentric circles with a spot in their center—an astrological symbol. Engraved on the signet are the letters h E T h on an oval base. "Heth" is a sacred name for Jehovah, and the Gnostics use these four letters very frequently on their mystic insignia. The ring in the illustration is of 15th century production and probably of English derivation.

And during recent times even civilized Europe reveals faith in the amulet. One of the many of these charms (and it makes a

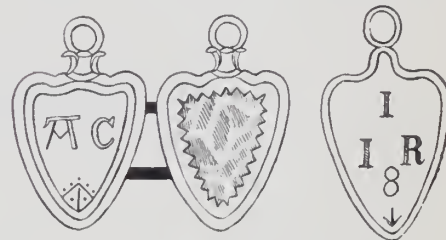

FIG. 8—FLINT ARROW HEAD RINGS.

neat ornament) is the flint arrowhead of the "stone age." Picked up by the peasantry, with no knowledge of a paleolithic stage of human history, they call these flint weapon tips "Elf-arrows," supposed by them to come from the clouds shot by the fairies. They are nearly always mounted in silver, with the reverse having some mystic inscription and the obverse left in the rough "chipped" form. The Scotch are much "addicted" to these charms, one of the two (Fig. 8) illustrated herewith having for over 50 years (until recently) been worn by an old Scotch lady. The silver mounting of these two probably date from the 17th century. Scandinavians use them as charms, as do the Italians. In Italy, however, they are known as "tongues of St. Paul. When found by the peasants they kneel down and pick them up with their tongues and then preserve them as amulets.

The toadstone ring had the lovely attribute of keeping the fairies away from new-born babes—also their mothers. It used to be a capital remedy for kidney troubles, for which the patient dipped the ring in water and then drank it (the water, not the ring). But toadstones were very scarce and greatly prized. They were found in the 'heads of certain maile toads.'

The loss of a betrothal ring has always been considered an ill omen. It is still so considered, and the loss of rings containing large rubies or diamonds have been known to seriously unhinge the minds of otherwise level-headed men and women.

LOUIS KAHN

MOSES KAHN

SAMUEL H LEVY

L. & M. Kahn & Co.

Importers and Cutters of

DIAMONDS

170 Broadway, cor. Maiden Lane, New York

AMSTERDAM: 2 TULP STRAAT

CUTTING WORKS: 29 GOLD STREET

Arnstein Bros. & Co.

Importers and Cutters of

DIAMONDS

65 Nassau Street

New York

LONDON: Audrey House, Ely Place

AMSTERDAM: 6 Tulp Straat

ALBERT LORSCH.

N. Y. Telephone Call, 2161-2 John.

ALFRED KROWER

ALBERT LORSCH & CO.

LORSCH BUILDING, 37 and 39 MAIDEN LANE, NEW YORK

131 Washington Street, Providence, R. I.

HEADQUARTERS for CORAL

Coral Cameos

Coral Boutons

Coral Strings

Coral Pendants

Coral Flowers

Coral Cabochons

REPOUSSÉ WORK AND CHASING*

ILLUSTRATED AND DEMONSTRATED BY AN EXPERIENCED ARTISAN

(Continued from issue of Feb. 5.)

TURNING now from the East to the West of Europe, we find that in the ninth and 10th centuries, when the Byzantine Empire had already had a continued existence and civilization for centuries, Central and Western Europe was still comparatively barbaric. But although the West could not boast of such an ordered existence as the Eastern Empire, it was well versed in most of the artistic crafts, and much beautiful work must have been made, judging by the glimpses we get of it from the very few specimens that still exist to illustrate the art of Central and Western Europe, covering such a period as represented by a thousand years (first to 10th century, A.D.). The Goths and Vandals, Franks, Merovingians, Saxons, Danes, all were well versed in the various crafts, and the chronicles and inventories tell us of beautiful work made for churches and kings. In fact, owing to the scarcity of actual work, it is to manuscripts that we must turn for the history of the gold and silversmith's art before the Middle Ages.

OLDEST PIECE OF PLATE.

Perhaps the oldest piece of plate made in Western Europe still in existence, is the gold chalice and paten of Gourdon, which is now kept in the National Library at Paris. It is of the Merovingian period (sixth century), has the large bowl typical of all early chalices, and is decorated in the barbaric style with uncut stones and filigree work. This style was practised with variations for centuries, throughout Central and Western Europe, and reached its zenith in the 12th century, when some of the finest work since the Antique was produced. It was a style eminently suited for working in metal, generally composed of simple motives and units skilfully designed, and proving that the craftsmen thoroughly understood both the advantages and limitations of the material in which he was working. There was no attempt to copy forms generally associated with architecture or woodwork, although in the 13th century, with the advent of the Gothic period, architectural forms were used in metal with good effect. With the Carolingian revival came a modification of this style, the figure being used more, as in classical art, whereas before it had been used only in a very conventional and often crude manner. One or two fine examples of the work of this period have come down to us, notably some book-covers with embossed figure work and filigree with cabochon stones, which are preserved in the Library in Paris. Another fine piece is the altar-front in the Church of Saint Ambrose at Milan. Most of this work originates from the monasteries in the Rhine Valley, which, with the end of the tenth century, became

the center of a great artistic movement under the Ottos.

CLOISSONNÉ ENAMELING INTRODUCED.

It was at this time that cloisonné enameling was introduced here from the East, Byzantine influence making itself felt possibly through the marriage of the future Otto the Second with a Byzantine Princess. At Trier and Aix-la-Chapelle some very fine metal work is still preserved, while the book-cover now at Gotha with enamels and embossed figures of Otto the Second and his Empress Theophano and the Evangelists, is the finest of its kind in Germany, dating from the time when Egbert was Archbishop of Trier, who greatly encouraged the artistic crafts for the production of ecclesiastical work. This style of work was continued both in Germany and France, until the middle of the 12th century; the so-called chalice of Saint Remy from the treasury of the Cathedral of Reims, which is considered one of the most beautiful chalices in existence, being of this date. In the latter half of the 12th century the adoption of a champlevé enameling caused another variation, and filigree work as a method of decoration disappeared to a great extent. Champlevé enameling lasted longest in the South of France, but the rapid development of the Gothic style in the thirteenth century, both in Northern France and the Rhine Valley, caused yet another and more drastic change in the appearance of metal work. Architectural forms were now gradually introduced as methods of decoration, and this style gradually extended all over Central and Western Europe. It was at its best in the fourteenth century, but in the middle of the following century signs of decay are noticeable, the imitation of architectural forms was pushed to extremes, and the whole work lacks the dignity and simplicity of the earlier work.

THE GOTHIC STYLE.

The Gothic style was essentially characteristic of the Middle Ages. It borrowed little from ancient classic art, and sought for inspiration entirely in the manners and customs of the time. The beginning of the thirteenth century marked the advent of this new style, when the old form of architecture, founded on the use of the classic column and round arch, was displaced by a totally different type of architecture, whose chief characteristics were the pointed arch and the lighter and more delicate form of column and window. This exercised an overpowering influence on the gold and silversmiths of the time, who more and more introduced architectural forms into their work. At first, in the 13th and 14th centuries, this was attended with most happy results, and the metal-work of this period, both from an artistic as well as technical point of view, reached a high standard of excellence; but by the end of the 15th century this copying of essentially architectural forms was pushed to extremes, and the

end was at hand. The Spaniards called this style of metal-work *plateresca* (silver architecture), a very appropriate term. Another notable feature of the metal-work of this period is the increased knowledge of the figure, and the consequent development in ornamental statuary in gold and silver. The life and splendor of the Middle Ages gave ample scope to the artist for his figure-work, and the monks in their costumes, knights in armor, and women in the picturesque dresses of the times, are all to be seen reproduced on the shrines, altars, reliquaries, chalices, and the various other objects in metal still in existence, as well as in the form of statuettes. One of the finest examples of the latter type is the silver figure of the Virgin and Child, from the treasury of Saint Denis, which is now preserved in the Louvre. It is of the early 14th century, worked out of sheet metal in repoussé, and the inscription round the base on which it stands gives us the exact date—1339—when it was made to the order of Queen Jeanne d'Evereux. It is beautifully modeled, quite as worthy of the master-sculptor as of the craftsman working in silver, and the plastic qualities of the metal have enabled the artist to give a suppleness and thin appearance to the draperies, which one seldom sees in marble or ivory sculptures.

IN ITALY.

Italy produced more figure work in the precious metals than any other country in Europe, many of the great Italian sculptors of this period commencing their careers as gold and silversmiths; among these may be mentioned Luca della-Robbia, Antonio del Pollaiuolo, Lorenzo Ghiberti (the maker of the bronze gates of the baptistry of Florence), and Antelotto Bacciforte. Two of the most remarkable pieces of Italian silverwork of this period are the silver altar of Pistoia, and the altar of St. John the Baptist in Florence. The altar of Pistoia is of the 14th century, and is chiefly composed of a number of bas-reliefs, dealing with the life of St. James. The weight of this altar is estimated at 447 pounds. The altar of St. John the Baptist was begun after the old altar in the same place had been melted down in 1366, and was not completed until 1477. It is about 3½ yards in width, 3 feet, 3 inches deep, and 4 feet, 3 inches in height. Each of the ends has four bas-reliefs, arranged like those in the front, which has eight, but two are wanting and are filled in with paintings. They deal with the life of the saint, and are worked in high relief. The frieze is made up of 43 niches, containing small silver figures, while the framework enclosing the reliefs is richly decorated with windows, niches filled in with translucent enamel over reliefs, and niello in the best Gothic style. These two altars are masterpieces of the best Italian goldsmiths of the 14th and 15th centuries, when Gothic art had reached its highest perfection in Italy.

(To be continued.)

The authorities at Mattoon, Ill., are seeking the whereabouts of E. J. Collins, who recently secured a \$50 watch from Herron Bros., at that place, and disappeared before making full payment for it.

*All rights reserved. Copyright, 1907, in the United States by the Jewelers' Circular Publishing Co., and in Great Britain by the Watchmaker, Jeweler, Silversmith and Optician.



RINGS



RINGS are always in demand, and are always salable, provided you have the right kind to sell. We have—

RINGS of every description: signet rings, diamond rings, fancy rings, rings of every style and combination of stones.

RINGS that satisfy the most critical and appeal to every taste and fancy.

RINGS You can sell. *Write us or wire us any time. We are always ready for your order.*

HAYDEN W. WHEELER & CO., Importers

AMSTERDAM, 2 Tulp Straat

2 Maiden Lane, NEW YORK, N. Y.
Phone, 7365 Cortlandt

LONDON, 50 Holborn Viaduct

EDUARD VAN DAM

CUTTER OF

DIAMONDS

CUTTING SHOPS:

ANTWERP

41 Rue de la Province (Sud.)

CABLE ADDRESS, MADNAV

NEW YORK

437-439 Fifth Ave.
Cor. 39th St. Knabe Bldg.

TELEPHONE, 5879 38TH ST.
CABLE ADDRESS, DEVRIVAN

AMSTERDAM

55 Ruysdaelstraat

CABLE ADDRESS, MADNAV

LONDON OFFICE, 22 Holborn Viaduct

AMSTERDAM
2 Tulpstraat

LONDON
40 Holborn Viaduct

OPPENHEIMER BROS. & VEITH.

CUTTERS OF DIAMONDS.

Cutting Works
43-45-47 John Street

NEW YORK
65 Nassau Street

RUDOLPH NOEL

PHILIP NOEL

RUDOLPH NOEL & CO.
IMPORTERS AND CUTTERS OF DIAMONDS

2 Tulp Straat, AMSTERDAM

37-39 Maiden Lane, NEW YORK

THE NEWS FROM LONDON

British Trade Extremely Unsatisfactory—Many Unemployed in Silver Industry—Conditions in Birmingham, Sheffield, Coventry, Scotland and Ireland Also Bad—Movement to Encourage Day Classes in Jewelry Instruction—London Lapidaries Annoyed Because Cullinan Diamond Is Being Cut in Amsterdam.

LONDON, March 1.—The condition of trade in Great Britain is extremely unsatisfactory. In every quarter of the kingdom complaints come to me that trade is "awfully bad." It is, indeed, almost out of memory when we try to recall a February which has shown such poor results. I can remember well the condition of affairs in the early 80s, but I cannot call to mind so much dissatisfaction with things in general, or the jewelry and allied trades in particular. Many things militate against London trade; the metropolis is, so to speak, the pulse of the kingdom, and all commercial ailments are felt very acutely there. I cannot in all my experience, extending over 31 years, remember so many men actually unemployed in the silversmithing industry, or such a regular system of "short time" in vogue. The jewelry trade is not quite so bad, but there is comparatively little to choose between this and the before-mentioned trade. Watchmakers are not only slack, but prices have been cut to such an extent that wages must now be at a minimum. Some idea of the very bad condition of the London silversmithing industry may be gauged from the statement that 43 candidates are asking for the votes of subscribers to the Silver Trade Pension Society. Many of the men I have known from my boyhood and they include some of the finest silversmiths of the last half of the 19th century.

* * *

In Birmingham trade is also very bad; buying has been practically *nil* and many find themselves in a tight corner financially. Workpeople are on very short time, or totally unemployed. Sheffield has also seen an unsatisfactory month, but as the month closes there is a gleam of hope and a promise of regular work for some, as very large admiralty orders for electro-plated goods have been secured by fortunate Sheffield firms. In the cutlery trade matters are particularly quiet and there is a remarkable scarcity of orders.

* * *

Coventry watchmakers, cycle and motor makers are not busy, while trade in the north of England and Scotland, which has been for some time very unsatisfactory, is now threatened by labor troubles in the engineering and shipbuilding industries. Ireland still remains very quiet, while the slump is also experienced in every provincial town. So far I have been able to report increasing Board of Trade returns; now, even in this direction, the tide has turned, for in the last published figures we find a decrease of over £4,000,000 in our national imports, while exports have decreased to the extent of £2,750,000. In my opinion, the situation is not due to our fiscal position, but is part of the general decline. The student of political economy knows that cycles of good and bad trade may generally be expected every 10 years.

There is historical proof of this, so we must bide a-while and possess our souls with patience.

* * *

Things are moving apace with regard to technical and art education for those engaged in the silversmithing and jewelry centers. This month a particularly important meeting was held at the Birmingham Jewelers' School in order to strengthen the movement for afternoon classes, the main object of the meeting being to engender enthusiasm among the foremen and men who work by the "team" system and to persuade them to use their influence with the youngsters under them and also make it possible for them to attend afternoon classes. A resolution to the following effect was carried: "That this meeting of employers and employed, approving of the system of afternoon classes, and considering they should be heartily supported by the trade, pledge themselves, in conjunction with the Birmingham Jewelers and Silversmiths' Association, to use every effort to further the art and technical training of the young people in the trade." It was mentioned that whereas 500 students attended the evening classes only 65 went to those held in the afternoon. In London the same spirit is abroad, and I understand that within the next few weeks a meeting will be held—probably in the Goldsmiths' Hall—for the purpose of getting London jewelry and silverware manufacturers to petition the London County Council to provide day classes in practical design for those engaged in the jewelry and silver trades. There are already day classes for those who will later enter the trade and also Saturday morning classes for practical work, at the Central School of Arts and Crafts, organized at the suggestion of the London Wholesale Jewelers Association some years ago.

* * *

Not a little annoyance is shown by London lapidaries at the sending of the "Cullinan" Diamond to Amsterdam to be cut. It seems, indeed, ironical that one of the very men who will have the most to do with the diamond was at one time employed in Hatton Garden. There can be no doubt about the ability of several of our London gem cutters. Some are perfect artists and I think they have reason to complain; although, after the late Prince Consort's experience of cutting the Koh-i-noor in London, it is hardly to be wondered at that King Edward's advisers recommended that the great stone be cut in Amsterdam, where much practice should indeed make perfect.

* * *

The leader of the labor members in the House of Commons has introduced a bill for the purpose of regulating home work in the electro-plating and other trades. The maximum number of persons living in a dwelling house which may be used for the

purposes of manufacture is fixed and they must have at least 250 cubic feet of space each, and it is further stated that if the room used for purposes of manufacture is used by night as a sleeping apartment then there must be 400 cubic feet of space to each person.
St. GEORGE.

Examination of Adolph L. Hodes in Bankruptcy Proceedings Begins at New York.

The examination in the bankruptcy of Adolph L. Hodes, 65 Nassau St., New York, who filed a voluntary petition recently in the United States District Court, was begun last Wednesday before Referee Allen, 67 Wall St., New York.

Mr. Hodes testified that he moved to his present location, 65 Nassau St., from 45 Maiden Lane, about five years ago, and that he handled a general jewelry line, and that he conducted the business personally.

He said that he read over the schedules in bankruptcy before signing them, and so far as he knew they were correct with the exception of the omission of a few accounts due him. He testified that he had paid his attorney, Jesse Epstein, \$1,000 to see him through bankruptcy. His attention was called to the fact that the schedules did not record such a payment.

His check book showed that five days before the petition in bankruptcy was filed a check for \$1,149 had been drawn, which Mr. Hodes explained was the balance due his father-in-law, C. Brothers, for the rental of property at 99 Hester St. He said that he had the power of attorney in the rental of this property, and that he acted for his father-in-law. The leases on the property were admitted as exhibits signed by Mr. Hodes individually. He was instructed to produce his authority as having power of attorney at the next meeting. He said that the money received from the rentals had nothing to do with his business.

When asked why he had entered the receipt of the money on his cash book, he explained that the amount was not large enough to open a separate account for, so he deposited it in the bank and recorded it on his cash book.

Jan. 23, seven days previous to the time of the filing of the bankruptcy petition, the bankrupt paid to Minnie Brothers \$2,000. He explained that he had not paid the money which he had borrowed from her before, because he needed the money for other purposes. At this point, Frederick N. Van Zandt, the examining attorney, asked for an adjournment until March 12, at 11 A. M. A meeting is called for the same day at 10:30 A. M., to consider an offer of \$7,500 made for the stock.

Fred Parshall, Jr., a member of The Tuttle & Parshall Co., Plattsburgh, N. Y., is spending the month of March in Florida, where he expects to do some tarpon fishing.

E. I. Waddell, Presque Isle, Me., has the sympathy of his friends in the trade in his bereavement caused by the death of his wife, Feb. 17. Mr. and Mrs. Waddell were married Nov. 6, 1905. She is survived by her husband, an infant daughter, a mother and three brothers.

Not One Stone

has ever come near attaining the popularity of the Reconstructed Ruby—the Hope Sapphire following next. * * * Comparatively inexpensive, these two Gems are within the reach of all, their demand increasing rapidly with their introduction to the general public. * * * We have realized that these Scientific Gems are articles that have come to stay, and have accordingly equipped ourselves for their uninterrupted production. Our facilities for cutting these stones enable us to fill all possible orders without delay.

L. Heller & Son

Importers of Precious and Imitation Stones
68 NASSAU STREET, NEW YORK

PARIS
39 Rue de Chateaudun

PROVIDENCE
212 Union Street

IDAR
14 Hauptstrasse

ORDER

DIAMONDS

ON MEMORANDUM FROM

ALFRED H. SMITH & CO.

170 BROADWAY, NEW YORK.

Corner Maiden Lane.

Also 475 FIFTH AVENUE.

London,
6 Holborn Viaduct.

Chicago,
103 State Street.

MEYEROWITZ
BROS

MEYEROWITZ BROS.

IMPORTERS OF

DIAMONDS

PRECIOUS and
SEMI-PRECIOUS STONES

ESTABLISHED 1896

NEW YORK: 37-39 Maiden Lane
PARIS: 58 rue de Maubeuge
AMSTERDAM: 2 Tulpstraat

MEYEROWITZ
BROS

Tel. 4457 } Cort.
4458 }

JOHN M. RICHARD 2 MAIDEN LANE
Room 302, NEW YORK

American Pearls and Baroques

MATCHED PAIRS FOR EARRINGS The Largest and Finest Assortment in the Market, Mounted and Unmounted.

WORKSHOP NOTES
for Jewlers and Watchmakers
Cloth :: Postpaid, \$2.50
Published by
The Jewelers' Circular Pub. Co.,
11 John St., New York

The Career of the Late August Schnell.

TROY, N. Y., March 4.—August Schnell, who died last Saturday morning at his home, 111 4th St., this city, was one of Troy's leading business men, as well as one of the most prominent jewelers of this section. His death, therefore, is a distinct loss to the commercial world of Troy, and is deeply regretted. Mr. Schnell was stricken with pleuro-pneumonia less than a week before his death, and grew steadily worse until his heart was unable to stand the ravages of the disease.

Deceased, who was a native of Hanover, Germany, was born April 22, 1845. In early life he came to the United States, going first to Boston, but later moving to Troy, and in 1880 opened a jewelry business on Congress St., between 3d and 4th Sts., this city, where he laid the foundation of the business, which he conducted so long and so successfully. He occupied a store on the Congress St. side of the Grand Opera House, and continued here until he moved to the present establishment, 83 3d St., four years ago, where the business has since remained.

Mr. Schnell was a man of strong, forceful character, whose sturdy honesty and upright principles in his business dealings won for him the respect and esteem of his associates, his customers and even his business competitors; these traits combined with his business acumen and common sense caused his steady success throughout his career.

Though a strong Republican in politics, Mr. Schnell never held or sought public office. He was prominent in the fraternal circles and especially in the Masonic order, and the Knights of Pythias, being a member of Apollo Lodge of the former, and Guttenberg Lodge of the latter. Mr. Schnell was twice married and his second wife, who was Miss Lucinda Elliott, of this city, survives him.

The funeral services were held Monday afternoon from Mr. Schnell's residence, and were in charge of Rev. E. W. Babcock, of the Holy Cross Church. The pallbearers were members of the organizations with which Mr. Schnell was connected.

Hjalmar S. Anderson, Worcester, Mass., Goes Into Voluntary Bankruptcy.

WORCESTER, Mass., March 6.—Hjalmar S. Anderson, doing business as Robinson & Anderson, with a retail jewelry store at 373 Main St., filed a voluntary petition in bankruptcy in the United States Court at Boston, and the schedules which accompany the petition show liabilities of \$17,979.45, and assets of \$7,950. The assets enumerated consist of stock in trade valued at \$5,000 and fixtures and machinery valued at about \$1,500 with book accounts of \$1,600 insurance policies and miscellaneous items.

Mr. Anderson's business was started over 50 years ago by A. L. Burbank, who began it in 1851, and about 20 years ago Mr. Anderson entered the employ of Mr. Burbank, as a watchmaker. He remained with the concern and its successors, A. L. Burbank & Co., Robinson-Hilton Co., and W. H. Robinson & Co., becoming a partner in the business, after the failure of W. H. Robinson & Co., in 1904. Mr. Rob-

inson died in September, 1905, since which time Mr. Anderson continued alone.

There are about 100 unsecured creditors, the principal of whom are: Henry Cowan, Boston, \$2,227, for merchandise and notes; Adolph Goldsmith & Son, \$2,137, and Adolph Rosenthal, \$1,401, both of New York City, for merchandise.

Jewelry, Clocks, Watches, Silverware and Kindred Lines Exported from New York.

WASHINGTON, D. C., Feb. 29.—The following were the exports of jewelry, silverware, optical goods, clocks, watches and kindred lines from the Port of New York for the week just ended:

- Belize: 1 case jewelry, \$101.
- Bremen: 1 case silverware, \$150; 2 cases watches, \$770; 2 cases plated ware, \$185.
- Bombay: 44 cases clocks, \$942.
- Buenos Ayres: 2 cases watches, \$2,055; 29 cases clocks, \$1,861; 1 case optical goods, \$195.
- Callao: 1 case watches, \$130.
- Calcutta: 130 cases clocks, \$1,663.
- Colon: 11 cases clocks, \$445.
- Curacao: 3 cases plated ware, \$170; 2 cases jewelry, \$120.
- Glasgow: 16 cases clocks, \$157.
- Guayaquil: 2 cases jewelry, \$166.
- Hamburg: 2 cases jewelry, \$620; 2 cases optical goods, \$1,265.
- Havre: 1 case silverware, \$355; 3 cases jewelry, \$200; 1 case clocks, \$243; 1 case silverware, \$755; 5 cases optical goods, \$968; 2 cases jewelry, \$300.
- Havana: 3 cases jewelry, \$692; 1 case plated ware, \$128.
- Liverpool: 1 case silverware, \$157; 3 cases clocks, \$150; 1 case jewelry, \$300.
- London: 4 cases clocks, \$200; 5 cases plated ware, \$100; 6 cases watches, \$1,114; 3 cases jewelry, \$1,428; 81 cases clocks, \$2,019; 3 cases thermometers, \$175; 13 cases optical goods, \$6,254.
- Macoris: 5 cases plated ware, \$117.
- Manchester: 67 cases clocks, \$716.
- Melbourne: 55 cases plated ware, \$1,850; 301 cases clocks, \$5,301; 6 cases optical goods, \$1,638; 4 cases plated ware, \$615; 1 case optical goods, \$127; 2 cases watches, \$607; 23 cases clocks, \$311; 3 cases watches, \$829.
- Mollendo: 1 case silverware, \$160; 1 case jewelry, \$1,083.
- Montevideo: 1 case jewelry, \$885; 12 cases clocks, \$180.
- Para: 11 cases clocks, \$478.
- Prague: 1 case silverware, \$700.
- Rio de Janeiro: 3 cases plated ware, \$475.
- Rosario: 245 cases clocks, \$2,958.
- Sheffield: 13 barrels jewelers' sweepings, \$9,656.
- Singapore: 6 cases scopes and views, \$2,000.
- Shanghai: 2 cases watches, \$310; 1 case precious stones, \$5,400.
- Southampton: 4 cases clocks, \$100; 1 case optical goods, \$469; 13 cases watches, \$2,489; 17 cases watches, \$3,299; 3 cases jewelry, \$378; 1 case scopes and views, \$240.
- Valparaiso: 4 cases clocks, \$119.
- Zanzibar: 8 cases clocks, \$104.

A. P. Staley, High Point, N. C., having recently resigned as secretary of the North Carolina Retail Jewelers' Association, this body has appointed Frank Jolly, of Raleigh, to that position. The annual meeting of this association will be held in Raleigh some time during the latter part of April or the first part of May. H. Mahler's Sons, of Raleigh, have invited the members who will be present at the meeting to participate in a barbecue, which will be held at the Mahler farm after the convention. An excellent programme is being arranged, and President Bernau and the other officers are making a strong endeavor to have every member of the association present. Every jeweler of the State is invited to come to Raleigh and participate in the proceedings of the convention.

Death of George O. Street.

George O. Street, one of the oldest manufacturing jewelers in the trade, who for many years was a familiar figure in the Maiden Lane district, New York, and a man highly respected for his sterling qualities, died at his home, Great Barrington, Mass., Tuesday of last week, where he had lived since his retirement from the firm of George O. Street & Sons, in 1892.

Mr. Street was born, Dec. 19, 1816, in New York City, and came from old New England stock, his English ancestors having been among the first settlers in the New Haven Colony, 270 years ago. He was a son of Harvey Street and a descendent of the Rev. Nicholas Street, who was a co-



THE LATE GEORGE O. STREET.

worker with John Davenport at the settlement of New Haven.

Deceased began to learn the jewelry trade in 1831 with Diamond & Lilliston, but finished his apprenticeship with Downing & Baldwin, in Reade St. In 1837 he started in business in Broad St. on his own account, as a manufacturing jeweler, later forming a partnership with Moses G. Baldwin and John C. Downing, under the style of Geo. O. Street & Co., but upon the death of the latter continued alone. In 1863 his son, Geo. W. Street, the present senior member of the firm, was admitted, and later, H. Louis Street, his other son, became a partner in the firm, and the name changed to George O. Street & Sons. In 1892, his grandson, a son of George W. Street, was admitted into partnership.

Mr. Street was a member of St. John's Lodge F. & A. M., Norwalk, Conn., and a highly respected member of the Episcopal Church. He was held in high regard by his social and business associates and was a man who did much for the cause of humanity, always being a liberal giver to deserving charities.

Deceased is survived by two sons and a daughter who have the sympathy of the trade in their bereavement. The funeral was held Friday at Great Barrington.

Richard Williams was arrested about a week ago in a pawnshop in Wilkes-Barre, Pa., where he was attempting to dispose of several watch cases. He finally admitted that he stole the cases from a jewelry store.

Chester Billings & Son

1840

Successors to
Kandel, Barmore & Billings

1908

Importers of Diamonds
Other Precious Stones, and
Pearls, Diamond Jewelry

1840, Kandel & Barmore; 1866, Kandel, Barmore & Co.; 1880, Kandel, Barmore & Billings; 1897, Chester Billings & Son

New York, 58 Nassau Street, 29 Maiden Lane
London: 22 Holborn Viaduct, E. C. Paris: 53 Rue de Chateaudun
Amsterdam: 2 Tulp Straat

GEORGE H. HODENPYL.

WALTER N. WALKER.

HODENPYL & WALKER

IMPORTERS OF

DIAMONDS

OTHER PRECIOUS STONES
AND PEARLSMANUFACTURERS OF
FINE DIAMOND JEWELRY

373 FIFTH AVENUE, NEW YORK

Corner 35th Street

Telephone, 5093 Madison Square

CHAS. F. WOOD & CO. DIAMONDS

1 MAIDEN LANE

NEW YORK

EISENMANN BROS.

IMPORTERS OF

Pearls and Precious Stones

452 Fifth Avenue, New York
cor. 40th St., Knox Building

3 Rue St. Georges, Paris.

CENTENNIAL TIMERS

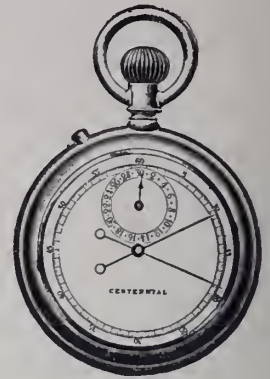

Without question the best plain and split second timers made.

Register with scientific precision. Substantially built and mechanically perfect.

Invaluable for athletic, mechanical and scientific observations. Cased in nickel. Much in demand during the racing season.

We also carry split chronographs with minute registers, cased in gold, gold filled and sterling silver.

All makes of American cases and movements.



Cross & Beguelin

31 Maiden Lane, N. Y.

Established
1863Telephone
480 John

Circular-Weekly's Stamping Act Passes Assembly of New Jersey, and May Soon Become a Law.

TRENTON, N. J., March 4.—THE JEWELERS' CIRCULAR-WEEKLY'S State Stamping Law, drawn to conform with the National Stamping Law, is likely to become a law in this State at this session of the legislature. The law, which, as already told by THE CIRCULAR-WEEKLY, was introduced a short time ago by Wm. Riker, Jr., with the backing of the manufacturing jewelers of Newark, passed the Assembly, a week ago, and is now in the Committee of the Senate by which there is every reason to believe it will be favorably reported. It will probably be passed next week, as it passed the lower house without an adverse vote.

The bill reads as follows:
AN ACT PROVIDING FOR THE STAMPING OF GOLD, SILVER AND THE ALLOYS THEREOF, AND IMPOSING PENALTIES FOR THE VIOLATION OF THE PROVISIONS THEREOF.

Be it enacted by the Senate and General Assembly of the State of New Jersey:

1. Any person, firm, corporation or association, who or which makes for sale, or sells, or offers to sell or dispose of, or has in his, her or its possession with intent to sell or dispose of, any article of merchandise made in whole or in part of gold or any alloy of gold, and having stamped, branded, engraved or imprinted thereon, or upon any tag, card or label attached thereto, or upon any box, package, cover or wrapper in which said article is encased or enclosed, any mark, indicating, or designed or intended to indicate, that the gold, or alloy of gold, in such article is of a greater degree of fineness than the actual fineness or quality of such gold or alloy, unless the actual fineness of such gold or alloy in the case of flat ware and watch cases be not less by more than 3-1000ths parts, and in the case of all other articles be not less by more than one-half karat than the fineness indicated by the marks stamped, branded, engraved or imprinted upon any part of such article, or upon any tag, card or label attached thereto, or upon any box, package, cover or wrapper in which such article is encased or enclosed, according to the standards and subject to the qualifications hereinafter set forth, is guilty of a misdemeanor; *provided* that, in any test for the ascertainment of the fineness of the gold or its alloy in any such article, according to the foregoing standards, the part of the gold or its alloy taken for the test, analysis or assay shall be such part or portion as does not contain or have attached thereto any solder or alloy of inferior fineness used for brazing or uniting the parts of said article; *provided further*, and in addition to the foregoing tests and standards, that the actual fineness of the entire quantity of gold and of its alloys contained in any article mentioned in this section (except watch cases and flat ware), including all solder, or alloy of inferior metal used for brazing or uniting the parts of the article (all such gold, alloys and solder being assayed as one piece), shall not be less by more than one karat than the fineness indicated by the mark stamped, branded, engraved or imprinted upon such article, or upon any tag, card or label attached thereto, or upon any box, package, cover or wrapper in which said article is encased or enclosed.

2. (a) Any person, firm, corporation or association, who or which makes for sale, or sells, or offers to sell or dispose of, or has in his, her or its possession with intent to sell or dispose of, any article of merchandise made in whole or in part of silver or of any alloy of silver, and having marked, stamped, branded, engraved or imprinted thereon, or upon any tag, card or label attached thereto, or upon any box, package, cover or wrapper in which said article is encased or enclosed, the words "sterling silver" or "sterling," or any colorable imitation thereof, unless 925-1000ths of the component parts of the metal appearing or purporting to be silver, of which such article is manufactured, are pure silver, subject to the qualifications hereinafter set forth, is guilty of a misdemeanor; *provided*, that in case of all such articles there shall be allowed a divergence

in fineness of 1-1000ths parts from the foregoing standard.

(b) Any person, firm, corporation or association, who or which makes for sale, or sells, or offers to sell or dispose of, or has in his, her or its possession with intent to sell or dispose of, any article of merchandise made in whole or in part of silver or of any alloy of silver, and having marked, stamped, branded, engraved or imprinted thereon, or upon any tag, card or label attached thereto, or upon any box, package, cover or wrapper in which such article is encased or enclosed, the words "coin" or "coin silver," or any colorable imitation thereof, unless 900-1000ths of the component parts of the metal appearing or purporting to be silver, of which such article is manufactured, are pure silver, subject to the qualifications hereinafter set forth, is guilty of a misdemeanor; *provided*, that in the case of all such articles there shall be allowed a divergence in fineness of 4-1000ths parts from the foregoing standards.

(c) Any person, firm, corporation or association, who or which makes for sale, or sells, or offers to sell or dispose of, or has in his, her or its possession with intent to sell or dispose of, any article of merchandise made in whole or in part of silver or of any alloy of silver, and having stamped, branded, engraved or imprinted thereon, or upon any tag, card or label attached thereto, or upon any box, package, cover or wrapper in which said article is encased or enclosed, any mark or word (other than the word "sterling" or the word "coin") indicating, or designed or intended to indicate, that the silver or alloy of silver in said article is of a greater degree of fineness than the actual fineness or quality of such silver or alloy, unless the actual fineness of the silver or alloy of silver of which said article is composed be not less by more than 4-1000ths parts than the actual fineness indicated by the said mark or word (other than the word "sterling" or "coin") stamped, branded, engraved or imprinted upon any part of said article, or upon any tag, card or label attached thereto, or upon any box, package, cover or wrapper in which said article is encased or enclosed, subject to the qualifications hereinafter set forth, is guilty of a misdemeanor.

(d) *Provided*, that in any test for the ascertainment of the fineness of any such article mentioned in this section, according to the foregoing standards, the part of the article taken for the test, analysis or assay shall be such part or portion as does not contain or have attached thereto any solder or alloy of inferior metal used for brazing or uniting the parts of such article; and *provided further*, in addition to the foregoing tests and standards, that the actual fineness of the entire quantity of metal purporting to be silver contained in any article mentioned in this section, including all solder or alloy of inferior fineness used for brazing or uniting the parts of any such article (all such silver, alloy or solder being assayed as one piece), shall not be less by more than 10-1000ths parts than the fineness indicated, according to the foregoing standards, by the mark stamped, branded, engraved or imprinted upon such article, or upon any tag, card or label attached thereto, or upon any box, package, cover or wrapper in which said article is encased or enclosed.

3. Any person, firm, corporation or association, who or which makes for sale, or sells, or offers to sell or dispose of, or has in his, her or its possession with intent to sell or dispose of, any article of merchandise made in whole or in part of inferior metal, having deposited or plated thereon or brazed or otherwise affixed thereto a plate, plating, covering or sheet of gold, or of any alloy of gold, and which article is known in the market as "rolled gold plate," "gold plate," "gold filled," or "gold electroplate," or by any similar designation, and having stamped, branded, engraved or imprinted thereon, or upon any tag, card or label attached thereto, or upon any box, package, cover or wrapper in which said article is encased or enclosed, any word or mark usually employed to indicate the fineness of gold, unless said word be accompanied by other words plainly indicating that such article, or some part thereof, is made of rolled gold plate, or gold plate, or gold electroplate, or is gold filled, as the case may be, is guilty of a misdemeanor.

4. Any person, firm, corporation or association,

who or which makes for sale, or sells, or offers to sell or dispose of, or has in his, her or its possession with intent to sell or dispose of, any article of merchandise made in whole or in part of inferior metal, having deposited or plated thereon or brazed or otherwise affixed thereto, a plate, plating, covering or sheet of silver, or of any alloy of silver, and which article is known in the market as "silver plate" or "silver electroplate," or by any similar designation, and having stamped, branded, engraved or imprinted thereon, or upon any tag, card or label attached thereto, or upon any box, package, cover or wrapper in which said article is encased or enclosed, the word "sterling," or the word "coin," either alone or in conjunction with any other words or marks, is guilty of a misdemeanor.

5. Every person, firm, corporation or association guilty of a violation of any one of the preceding sections of this act, and every officer, manager, director or managing agent of any such person, firm, corporation or association directly participating in such violation, or consenting thereto, shall be punished by a fine of not more than \$500, or imprisonment for not more than three months, or both, at the discretion of the court; *provided*, that if the person charged with violation of this act shall prove that the article concerning which the charge is made was manufactured prior to the passage of this act the charge shall be dismissed.

The procedure under this act will be by complaint and indictment by the jury as in other cases of misdemeanor.

Importations at the Port of New York.

Weeks Ended March 2, 1907, and Feb. 29, 1908.			
	1907.	1908.	
China, Glass and Earthen Ware:	1907.	1908.	
China	\$114,803	\$114,803	\$65,901
Earthen ware	27,666	27,666	7,058
Glass ware	37,238	37,238	19,246
Optical glass	4,898	4,898	1,549
Instruments:			
Musical	15,701	15,701	8,006
Optical	7,213	7,213	5,610
Philosophical	3,783	3,783	5,603
Jewelry, etc.:			
Jewelry	17,428	17,428	18,368
Precious stones	589,518	589,518	71,603
Watches	38,302	38,302	16,971
Metals, etc.:			
Bronzes	1,176	1,176	7,046
Cutlery	65,358	65,358	32,269
Dutch metal	5,159	5,159	1,200
Platina	40,764	40,764	61,447
Plated ware
Silverware	264	264	88
Miscellaneous:			
Alabaster ornaments	24	24	13
Amber	21,349	21,349	2,574
Beads	5,902	5,902	3,096
Clocks	10,133	10,133	2,051
Fans	7,118	7,118	190
Fancy goods	12,967	12,967	8,065
Ivory	11,453	11,453	6,955
Ivory, manufactures of..	239	239	187
Marble, manufactures of.	7,098	7,098	18,356
Statuary	38,187	38,187	6,975

Senator Simmons has introduced an amendment to the Post-Office Appropriation Bill to provide that the rates of postage on merchandise mailed at the distributing office of any rural free delivery route shall be five cents for the first pound, and two cents for each additional pound or fractional part of same. On parcels weighing less than a pound the rates would be as follows: For two ounces or less, 1c.; for over two ounces and not exceeding four ounces, 2c.; for over four ounces and not exceeding eight ounces, 3c.; for over eight ounces and not exceeding 12 ounces, 4c.; for over 12 ounces and not exceeding one pound, 5c. This rate would apply only at local post-offices for delivery to patrons on routes emanating from that office, or collected by rural carriers for delivery to the office from which the route emanates, and not to mail transmitted from one office to another, and would not apply to packages exceeding 11 pounds in weight.

ADDISON W. WOODHULL, President.
FRANK K. HUFF, Vice-President.

GILBERT T. WOODHULL, Treasurer.
WILLIAM J. McQUILLIN, Secretary

MOUNT & WOODHULL,

IMPORTERS OF

DIAMONDS,
OTHER PRECIOUS STONES,
PEARLS, ETC.

MAKERS OF

FINE
DIAMOND
JEWELRY.

26 Maiden Lane,

(Southwest Corner Nassau Street)

NEW YORK

EMERALDS, DIAMONDS
AND PEARLS

CABLE ADDRESS:
MILBAGG

BAGG & CO.
Successors to BAGG, PERINE & CO.
IMPORTERS
452 FIFTH AVENUE, at 40th Street
NEW YORK

TELEPHONE
NUMBERS:
917-918 BRYANT

RUBIES AND
SAPPHIRES

Pearl Necklaces and Collarettes.

Mounted
Diamond
Jewelry

of every
description.



Largest
assortment
of all kinds of
very fine, fancy
and rare gems,
including Pearls,
Diamonds, Rubies,
Emeralds and Sapphires.

**Particularly Fancy
Colored and Fancy
Shaped Diamonds.**

182 & 184 BROADWAY
NEW YORK

Leading Messrs.
Frederick & Co.
Emil Knopf
John W. Ruefer.
Frank L. Wood.

TURQUOISE

Matrix - Turquoise

Best the World Produces

WE ARE prepared to furnish
to the trade Matrix-Tur-
quoise in all shapes and sizes.

Exquisite Color and Markings

We cut Turquoise to order

Mines at Mojave County, Arizona

THE ARIZONA TURQUOISE MINES CO., Inc.

Cutting Works and Sales Office
171 Broadway, New York

SEND FOR CATALOG

Telephone 5728 Cortlandt

Practical Course in Adjusting

BY THEO. GRIBI,

COMPRISING

A review of the laws governing the motion of the
balance and balance spring in watches and
chronometers, and application of the principles
deduced therefrom in the correction of vari-
ations of rate arising from want of isochronism,
change of position and variation of temper-
ature.

ELUCIDATED AND DEMONSTRATED

by original experimental researches in the actual
problem, never before published, showing the
causes that are operative in the variation of
rate, and leading to correct remedies. To
which have been added chapters on

Published Price, \$2.50.

SPECIAL REDUCED PRICE, \$1.50,

Post prepaid.

250 pages, including 18 diagram plates; Fine
Paper; Large Type; Clear Illustrations; System-
atically arranged; Solid Binding.

THE JEWELERS' CIRCULAR PUB. CO.
Publishers

11 John St., cor. Broadway, New York.

Watch Case Law Explained.

Attorney Who Drew Bill Introduced by Congressman Vreeland Explains the Provisions of the Act.

In speaking, last week, to a reporter of THE CIRCULAR-WEEKLY about the bill introduced by Congressman Vreeland, which seeks to regulate the marking of watch cases by abolishing guarantees and providing for quality and quantity stamps, which bill was published in full in the last issue of this journal, George Cook, the attorney who has the matter in charge, made the following statement:

"For a number of years, during which time I have been very closely and intimately connected with most of the reputable case makers throughout the country, I have continually heard complaints concerning the evils growing out of the guarantee stamps in gold filled cases, and the desirability of abolishing the same. Some months ago, I came to the conclusion that the only course to pursue was to make it illegal to stamp a case containing any mark or marks indicating the length of time that such case would wear, and with this in mind, interviewed a number of the case makers as to the desirability of securing such legislation. The present bill is a result of these many interviews.

"The principal purpose sought to be accomplished by the bill is to prevent the marking of gold filled or gold plated watch cases with a guarantee of time during which the case will wear, whatever be the form such guarantee may take. The reason for doing away with such marking of filled and plated cases is three-fold: First, as a protection to the manufacturer; second, as a protection to the dealer, and third, as a protection to the consumer or the public. Under existing circumstances, the reputable manufacturer, who puts an adequate amount of gold in his cases, has no protection against inferior goods as the goods are largely sold according to the term of years for which they are guaranteed.

"By doing away with the guarantee and either stamping the goods in such a way as to show the quality and quantity of gold contained, or else not stamping at all, the business will get down to a basis of open and above-board competition, and the buyer will govern himself according to the actual known value of the article, or according to the reputation of the manufacturer.

"With regard to the dealer, so long as the goods are guaranteed to wear a certain number of years, the dealer is apt to feel that he is protected, and has no responsibility whatever; that if the case does not wear, he can simply fall back on the manufacturer and get a new one. I have been informed that some of the dealers have had a pretty severe lesson taught them where a company went out of business. During the past 10 or 15 years I have known of manufacturers of filled cases to start up and flourish a while, and then as suddenly go out of business, the result being that the dealer who has sold these fake cases to his customers, finds the manufacturer out of business and no one to fall back on to make the guarantee good. In many instances, the dealer has had to make

good out of his own pocket, at a serious loss.

"Perhaps the greatest amount of injury and injustice, however, is done to the public. A large quantity of watches are sold through the medium of auctions, installment dealers, peddlers and fakors of different kinds, and I am informed that thousands of cases have been passed off by this class of dealers upon the public stamped as guaranteed for 25 or 20 years, which were nothing more than brass, pure and simple.

"In addition to its prohibitory provision, making it illegal to stamp a guarantee of time or wear in a gold filled or plated case, the bill also provides that in the case of gold filled and gold plated watch cases the thickness of the interior and exterior plates should be given in decimals wherever the karat mark is placed upon the article. This reform has been so frequently discussed that it hardly needs any explanation. It is obvious that a complete statement in regard to a gold filled article where a quality mark is used, involves at least the three elements, namely, the use of the words "gold filled" or similar words, the quality mark, and marks or words indicating in some way the quantity of gold in the case. The consensus of opinion is that this last result can best be reached by stamping on the case the thickness of the outside and inside plates.

"I have visited and talked with many of the reputable manufacturers throughout the country, and have reviewed the provisions of the bill with them on a number of occasions, and I find them generally agreed that legislation of this character is very desirable."

Gem Importers to Fight Attempt to Collect 50 Per Cent. Duty on Manufactures of Agate, Coral, Etc.

A meeting of precious stone dealers was held last Wednesday afternoon at 35 Maiden Lane, New York, in reference to the notice issued by the United States Government stating that increased duty on all articles included in Par. 115 of the Tariff Law, such as manufacturers of agates and other semi-precious stones, all of which have heretofore been dutiable at 10 per cent., should be hereafter dutiable at 50 per cent. The contention of the Government was explained in full in the last issue of THE CIRCULAR-WEEKLY.

The meeting organized with Alfred Krower, of Albert Lorsch & Co., as chairman, and Jacob Goodfriend, of Goodfriend Bros., as secretary. A committee of three, consisting of Messrs. Goodfriend, Krower and Benedict, were appointed to engage counsel. Alfred H. Washburn, of Comstock & Washburn, has been engaged as counsel for the importers, and as soon as possible after the ruling goes into effect a test case will be brought. The meeting was largely attended and a desire was manifest on the part of those present to fight the additional duty in the courts. Those not in attendance at the meeting have since signified a desire to be numbered among the importers contending in the matter.

Par. 115 of the Customs Laws reads as follows: "Manufacturers of agate, alabaster, chalcedony, chrysolite, coral, cornelian,

garnet, jasper, malachite, marble, onyx, rock crystal or spar, including clock cases with or without movements not specifically provided for in this act, 50 per cent. ad valorem." This is the paragraph on which the Government bases its contention that the duty should be advanced. It has been the custom of the Treasury Department to classify all imports of these stones when partly manufactured as dutiable at 10 per cent. by similitude under Par. 435, providing for precious stones advanced in condition or value from their natural state by cleaving, splitting or other process.

It is said that the attention of the assistant secretary of the treasury has been called to the matter and he has been asked to change his ruling and has refused to do so, which leaves the Appraisers and Collector in a position where no other alternative offers other than to act according to the ruling and demand the 50 per cent. duty on these articles.

Examination in Bankruptcy of Jos. Brown & Co. Continues at Chicago.

CHICAGO, March 7.—One session of the examination into the affairs of Jos. Brown & Co., bankrupts, was held last Friday. Lawyers Ringer and Shrimski wanted to find out what Brown did with the cash he received from his auction sales during December, 1907. William B. Severn, auctioneer, testified that his firm had paid Brown \$2,200 in December, part cash and part checks. Brown testified he put all money he received into his business. Asked if it was possible it wasn't entered in the books, he said: "Maybe yes, maybe no." Sometimes, said the witness, he bought goods for cash and used the money that way. It was likely to happen, he said, that he would keep the money and make no entry.

Brown said he only signed the statement in June. He didn't know its contents. He refused under advice of his counsel, Hugo Pam, to answer several questions.

Referee Eastman was called. Pam said: "Don't let them scare you, Brown." Brown bravely replied: "I ain't scared."

Brown said he never had stock certificates of Jos. Brown & Co. in his hands and didn't know if he owned any. He didn't know "Pittsburg Joe," to whose restaurant he had sold 10 barrels of cut glass. "Pittsburg Joe's" restaurants are very low priced ones and heretofore not famous for displays of cut glass. A complete and impenetrable haze encompassed Brown in regard to statements made to the trade. He signed them and that was all he would say. He said he could neither read nor write.

Brown was asked if 48 hours prior to his failure he had bills of large denomination in his possession. He said he had one \$500 bill which he drew for himself from the bank and that was all he had.

Louis Byrens, an auctioneer, testified that on Feb. 5, the day before the failure, Brown showed him a large roll of bills, among which were two \$1,000 bills that Brown claimed he had just received a check for \$10,000.

When asked about his diamond business Brown again lost his memory. He admitted "kiting" checks with Max Weber, and said he did it with a thousand people.

W^M S. HEDGES & CO.,

IMPORTERS AND CUTTERS OF

DIAMONDS.

Precious Stones and Pearls.

170 Broadway, Corner Maiden Lane, New York.

27 Holborn Viaduct, London.

EMERALDS

IN CURRENT SIZES AND GEM PIECES

SAUNDERS, MEURER & Co.

65 NASSAU STREET

NEW YORK

F. A. JEANNE

Rubies and Emeralds

5 Square de l'Opera

PARIS, FRANCE

Cable Address

"GEMFINDER"

Western Union Code

STERN BROS. & CO.,

CUTTERS OF

DIAMONDS,

CUTTING WORKS:

138-142 West 14th St., N. Y.

68 Nassau St.,

NEW YORK.

CHICAGO,
103 State Street.

LONDON,
29 Ely Place.

ARTHUR REICHMAN

BUYS AND SELLS

AMERICAN BAROQUE PEARLS

65 Nassau St.

New York

ELSIE BEE'S FASHIONS.

EASTER NOVELTIES NOTED IN A LADY'S RAMBLES
AMONG THE JEWELERS.

THE alert jeweler uses every season as an opportunity to launch novelties, and in the approach of Easter he seizes a chance to express new ideas and attract trade. While he is somewhat limited in designs, there is still a large field open to him in this line, as is illustrated by a locket maker who is offering several new lockets. They are of Roman or rose gold, circular in shape, with enameled and stone-set design.

* * *

The chicken idea is also presented in a novel brooch—just the outlines being given in tiny brilliants. This pin is about an inch and a half in length.

* * *

A unique cross is made of four pieces of lapis lazuli, the lines being irregular—that is, not parallel, but slanting from the four extremities toward the center.

* * *

In graceful outlines, however, nothing is more attractive than the Celtic cross, especially the one that is fashioned from the ancient cross of Clonmacnoise, Ireland.

* * *

The enameled black cross with edges of gold and a half-pearl center from which issue rays of gold is more or less novel. It follows the Catholic design in shape.

* * *

In Easter scarf pins there is a simple gold cross with an enameled lily in its center. There are also the chicken and rabbit designs, carried out in enamel, with perhaps a single setting of a peridot, amethyst or topaz.

* * *

Easter bells appear upon several new brooches. These are either in the simple design of a bell with a pearl clapper hanging from a gold bowknot, or a bell on a wish bone, or, again, a bell as the central figure with an enameled lily on either side.

* * *

In crosses there is nothing more appropriate than the one of closely set amethysts. Like the amethyst rosaries, this cross perhaps sells the best at the Easter season—next, of course, to the small, inexpensive plain gold crosses. The topaz cross follows close to the amethyst one in popularity.

* * *

There is one novel application of an old idea in book marks that grows slightly away from the usual design of the faith-hope-and-charity style. It is simply a narrow band of purple ribbon, the length of a prayer book, from one end of which hangs a simple gold cross, while from the other suspends the star of Bethlehem.

* * *

One of these lockets bears simply a cross of diamonds on a Roman gold surface. Another has a lily design in relief at the base, with a spray of enameled leaves on either side and a small cross above. A third consists of an elaborate design—a slanting cross in brilliants resting on an open gold prayer book, surrounded by a circle formed of enameled lilies and stems.

ELSIE BEE.

STREET CLOCKS PULLED DOWN AND WRECKED.

Jewelers' Signs in Milwaukee, Wis., Forcibly Removed by Order of the Mayor — Action Declared Legal — Jewelers Formally Protest.

MILWAUKEE, Wis., March 6.—At 1 o'clock yesterday morning a detail of firemen, acting under orders of Mayor S. M. Becker, tore down the clocks of jewelers who had declined to comply with the order to remove all signs and obstructions from the streets of the city. No heed was given

Ave. and 6th St.; Alsted-Kasten Co., Wisconsin and Milwaukee Sts.

That the firemen experienced some difficulty in removing the clocks is shown by the remnants in the streets on the morning after the raid. Tackles, iron saws and other appliances were employed. The Seidel

costly sign-clock which had stood in front of the store, and displayed the mess in the show window with the following placard:

Ordered done by
S. M. Becker,
Candidate for Governor.

Mayor Becker later said he was not afraid of duty even if it did cost him a few votes.

Archie Tegtmeyer, whose sign is among the missing, denies the statement of the Mayor that the jewelers were given ample time in which to remove the clocks and other signs. He said he was assured a few hours before the raid was made that nothing would be done for some time. An ordinance is pending in the City Council which excepts clocks from the sign removal order.

MILWAUKEE, Wis., March 11.—That the steps taken by the members of the fire department acting under orders of Mayor Becker in removing the street clocks belonging to jewelers are legal and that the jewelers cannot recover damages was a verbal opinion given by City Attorney Kelly. The opinion was occasioned when Attorney Carl Heim, representing W. & E. Schmidt, 308 3d St., arrived at the city hall and in a conference with the city attorney said that suit would be instituted against the city for \$530 to pay for the clock which was smashed while the fire department was taking it down. The clock of Adam Bloedel, in front of the Plankinton house, was also destroyed and several jewelers maintained yesterday that their timepieces had been ruined or injured.

Another feature of the clock crusade developed when an injunction was served on city officials restraining the city from interfering with David Goldman, who says that he intends to again put up the clock at National Ave. and Grove St. The injunction was issued by Court Commissioner Donnelly.

The Milwaukee Jewelers' Club issued the



HOW A. BLOEDEL'S STREET CLOCK WAS COMPLETELY WRECKED.

hundreds of letters and telephone calls received by the police and the Mayor from people who desired that the clock signs be allowed to remain intact, owing to their utility to the general public in the downtown streets.

On March 4 the Mayor ordered warrants issued against the jewelers who had not obeyed. The jewelers took no action, and Mayor Becker then got a tip that injunctions would be served by the jewelers in question if city officials tried to remove the clocks.

At midnight the Mayor quietly ordered firemen to tear down the clocks, thus avoiding injunctions or opposition of any kind. When the work of destruction became public yesterday morning there was a storm of protest against the action of the Mayor, and the jewelers were advised to take legal action in the matter.

The jewelers whose clocks were summarily torn down and mutilated are as follows: A. Bloedel, 127 Grand Ave.; C. Preusser Jewelry Co., E. Water and Mason Sts.; Richard Seidel, 2d St. and Grand Ave.; A. J. Stoessel, 1097 3d St.; W. & E. Schmidt, 308 3d St.; A. Bringe, 12th and Walnut Sts.; D. Goldman, Grove St. and National Ave.; Archie Tegtmeyer, Grove St. and National Ave., and Herman Miller, Mitchell St. and Third Ave.

Orders were also issued for the summary removal of signs at the following jewelry stores, but when the firemen arrived the signs had already been removed by the owners: Joseph Wellstein & Co., National and Fifth Aves.; Charles Veicht, Grand

clock was attacked first and not harmed in removing it, but the Bloedel clock was a mass of ruin when the firemen got through with it. The chief of the fire department and 12 men, headed by the master mechanic of the department, made the raid.



SCENE IN FRONT OF ARCHIE TEGTMEYER'S STORE.

A secret meeting of the Milwaukee Retail Jewelers' Club was held soon after it was discovered that the clocks and signs had been removed so suddenly, and a statement to the public as well as legal proceedings are in prospect. The Seidel jewelry store gathered up the wreckage left of the

following statement in the public press:

Believing that the drastic, destructive and uncalled for tactics pursued by the Mayor, despite his promises and that of his secretary not to do so, in ordering the fire department to raze the clocks, calls for an explanation, the jewelers submit the following:

When the order was given to take down the

Goodfriend Bros

IMPORTERS OF PEARLS

Sapphires
Rubies
Opals
Emeralds

Aquamarines
Peridot
Gem Coral
Tourmalines

and OTHER
Precious and Imitation Stones

PEARL-OPAL-CORAL
& AGATE NECKLACES

PARIS:
10 Rue Cadet.
PROVIDENCE:
212 Union St.

9-11-13
Maiden Lane
NEW YORK

Geo. Brunswick, N.Y.

signs and it became known to the public that this order also included the public clocks, the jewelers were besieged by many of their patrons and the public in general to make every effort to retain the clocks as they were considered a public convenience.

With this in mind the undersigned called on the Mayor and explained the situation to him. The Mayor then stated that *no radical action would be taken*, and at his suggestion all advertising was removed from the clocks. The writer was again assured by the secretary as late as Wednesday afternoon that he, the secretary, considered it advisable to "let the matter rest." That same night, or rather early in the morning, the Mayor orders the fire department to take down the clocks, and, with two exceptions, these expensive clocks, the property of taxpayers, were absolutely wrecked.

It is neither the purpose or desire of the jewelers to defeat any city ordinance or to stand in the way of its enforcement, and they wish it understood that the action taken by them was the request of the public as expressed by the petitions signed by hundreds of citizens and which were to have been presented to the Mayor to-day. Milwaukee is the only city in the United States without street clocks.

"This crusade against signs and clocks has come about as suddenly that we've hardly had time to get our breath," said Louis W. Bunde, president of the Bunde & Upmeyer Co., "but something, of course, will have to be done to illuminate the streets. The city has taken down the illuminated signs and clocks. Now it's up to the city."

Mr. Upmeyer, vice-president of the firm, takes the same view of the situation as Mr Bunde.

"As far as we alone are concerned," he said, "the mayor's order works no harm. We never have permitted overhanging signs on our store, and our clock is so placed that it does not have to be removed. We close our store nights and our windows remain illuminated. The situation of our store is such that we are not hurt in the least by the order.

"When they say, however, that all signs should come down there should be no discrimination. If the clocks have to come down because they advertise the jewelers, then let the street car company's time-tables, which are placed on poles at the corners, be taken down, too. The time-tables are signs. They're advertising the business."

Archie Tegtmeyer said: "If the people make known to us their wish to have these clocks restored we shall go before the common council with a petition asking for a permit to replace them, as we regard them as a public convenience which we shall be glad to furnish."

Later an offer was prepared by the jewelers' club to the city, to give the sign-clocks to Milwaukee, providing the city will maintain them for public convenience.

Mr. Goldman in discussing his injunction said that he desires to re-erect his clock and that, fearing the city may interfere with his doing so, the injunction restraining such action is issued, pending the action of the circuit court. It is pointed out that the clock was razed "surreptitiously and in the night" by city officials. Mr Goldman also files an appeal with the circuit court asking that the temporary injunction be made permanent. In this appeal he states that his clock was erected at great expense to himself. He states that its value is \$1,000.

On the theory that street clocks are a public benefit, Alderman Yockey of the

CORAL

All Kinds of Coral
Specialties for Jewelers

**DROPS
BUTTONS
LENTILLES
CORAL
NECK-
LACES**

All Shades
and Sizes

Graduated and
Uniform

CORAL

**Extra Rose
CORAL
A Specialty**

Gold Medal
St. Louis, 1904

Grand Prix
Liege, 1905

CORAL MANUFACTURING COMPANY

BORRELLI & VITELLI

3 Via Amedeo,
Terre del Greco Italy

401 Broadway, New York
Telephone, 5112 Franklin

19 Rue d'Hauteville,
Paris, France

LOUIS FELDENHEIMER

Importer and Cutter of

PRECIOUS STONES AND PEARLS

41 MAIDEN LANE
NEW YORK

eventh ward introduced an ordinance into the common council Monday, March 9, providing that the city acquire a proprietary interest in the clocks removed from in front of jewelry stores two nights ago, and all others that may be erected, and that they be set up at the end of sidewalks or other prominent places on public thoroughfares.

The seventh ward alderman said that he had obtained the promise of every jeweler whose clock was taken down by the city of donating the timepieces to the city unconditionally, and if the city decides to erect them the jewelers will operate them at private expense. Mr. Yockey admitted that the jewelers might insist upon having the

Canada's Gold and Silver Marking Act Comes Into Operation March 13.

TORONTO, Can., March 5.—The Gold and Silver Marking Act passed last year by the Canadian Parliament comes into operation March 13, unless the date is postponed by the government. When the act was adopted there were strong objections taken to many of its provisions, as not being in the interests of the jobbing and retail branches of the trade, and it was passed on the understanding that it could be reconsidered at the present session.

For some time a committee, representing the different branches of the trade, has been engaged in the work of redrafting

guishing letters shall be used to denote the quality such as "R. P." for rolled plate; "G. F.," gold filled; "E. P.," electro-plate, and "Gilt," gold electro-plate. It is made an offense to make use of printed or written matter, or advertisements guaranteeing the time-wearing qualities of goods. The representatives of the manufacturers strongly opposed the reduction of the minimum gold standard to 9 kts., but the other branches were unanimous in its favor.

E. M. Trowern, this week, submitted the draft bill to the administration at Ottawa, and requested on behalf of the committee that the operation of the act now on the statute book should be postponed until July 1, to allow of the consideration of the proposed amendment by Parliament.

Bids Received and Contracts Awarded by Government Departments.

WASHINGTON, D. C., March 4.—The following bids have been received by the Bureau of Supplies and Accounts, Navy Department:

On hollow silver plated sugar bowls, chafing dishes, fruit dishes, vegetable dishes, etc. International Silver Co., Meriden, Conn., \$6,158.55.

On silver plated flat ware, including 264 dessert forks, 132 table forks, 348 dessert knives, 468 table knives, 12 butter knives, 396 coffee spoons, 60 dessert spoons, 108 tablespoons, 564 teaspoons and 72 salt spoons. International Silver, Co., \$935.40; E. H. H. Smith Silver Co., Bridgeport, Conn., \$968.

WASHINGTON, D. C., March 5.—The Navy Department has awarded the following contracts:

For 480 thermometers, Brooklyn Yard, Philadelphia Thermometer Co., \$452.40.

For 50 Boat and deck clocks, Washington Yard, Chelsea Clock Co., Boston, Mass., \$867.50 (only bidder).

For 30 quartermaster's spy glasses, Washington Naval Observatory, Bausch & Lomb Optical Co., Rochester, N. Y., \$442.50.

For 50 officers' of the deck spy glasses, Washington Naval Observatory, Bausch & Lomb Optical Co., \$420.

For 100 thermometers, Washington Naval Observatory, Philadelphia Thermometer Co., \$95.

For 100 binoculars, Washington Naval Observatory, Bausch & Lomb Optical Co., \$2,350.

For 20 prismatic binoculars, Washington Naval Observatory, E. Lietz Co., San Francisco, Cal., \$1,020.

The great "artificial diamond" case still interests Paris. *The Temps*, of that city, last week, said that the examining magistrate in the case of Lemoine, the electrical engineer, who is accused by Sir Julius Werner of obtaining from him by fraud more than \$300,000 in connection with an alleged invention for the manufacture of diamonds, is said to have discovered a person who supplied Lemoine with fusible plugs, in which it is supposed were concealed diamonds which were subsequently found in the crucibles in which the diamonds were alleged to be made. Lemoine has now formally charged Sir Julius with forgery and swindling in reference to documents Sir Julius submitted to the magistrate.



HOW THE CLOCK OF THE W. & E. SCHMIDT CO. WAS DESTROYED.

clock, for operating of which he is paying, stand before his place of business, yet of this he was not certain.

New York Jewelry Firm Asks Police to Help Find Salesman Who Disappeared Feb. 25.

S Kaplan & Co., 51 Maiden Lane, New York, have asked the police to find Samuel Zucker, a salesman, who left the offices of the concern, Feb. 25, with samples valued at \$4,162, for which he has not accounted. He was to return that night, members of the firm say, and when he did not do so, they traced the missing man to Philadelphia and Atlantic City, where they lost track of him.

Mr. Zucker, who is 38 years of age, was a member of another jewelry firm until a few weeks ago, since which time he has taken out jewelry for S. Kaplan & Co., selling it about New York City and returning each night.

The salesman is described as 5 feet 10 inches high, with black hair and eyes, having a heavy mustache and beard.

J. M. Wagner, optician at Reading, Pa., has caused the arrest of Reymond Lebo, 25 years old, who is accused of passing a worthless check.

the measure. The committee was composed of W. K. McNaught, M.P.P.; Thomas Roden and W. G. Ellis, Toronto, representing the manufacturers; Walter J. Barr, Toronto; A. Levy, Hamilton, and S. Lee, Toronto, representing the wholesale trade, and Jas. Ryrie, Benj. Kent and J. W. Johnson, Toronto, representing the retailers. Walter J. Barr was chosen chairman, and E. M. Trowern, secretary of the Retail Merchants' Association, which has taken an active part in agitating for a modification of the act, was appointed secretary.

The measure was recast and divided into four parts, dealing respectively with manufacturers of gold, silver, gold and silver-plated ware, and electro-plated ware. Its provisions were a good deal simplified, and several important changes were made as follows:

The minimum standard of gold to be manufactured or imported was fixed at 9, instead of 10 kt. The provision of the act prohibiting the manufacture or importation of all silver under sterling was struck out, and the stamping of silver of a lower quality than sterling was permitted, provided the actual quality is stamped in thousandths. No stamping of the date mark is required. Provision is made that distin-

MONTANA SAPPHIRES

AT ATTRACTIVE PRICES

Where uniformity of size, evenness of color and quality are essential, our stock of Montana Sapphires particularly commends itself.

Pearls and practically every precious and semi-precious stone but the diamond.

BUY FROM THE CUTTERS

AMERICAN GEM & PEARL COMPANY

14 & 16 CHURCH STREET, NEW YORK

London, 16 Holborn Viaduct

Paris, 39 Rue de Chateaudun

FROM MINES TO MARKET

Col. Daniel C. Dusenberry, Middletown, N. Y., Celebrates His 90th Birthday.

MIDDLETOWN, N. Y., March 4.—Col. Daniel C. Dusenberry, who celebrated the 90th anniversary of his birth at his home in this city yesterday, will celebrate the 70th anniversary of the date in which he embarked into the jewelry business in the window of a jewelry store then conducted by Ira Woore. At that time his sole possession consisted of a kit of tools, and with this small beginning he developed the large and successful business now long at 14 North St., this city, under the style of Daniel C. Dusenberry & Son.

Col. Dusenberry was born in Amityville, Orange County, in 1818 and at the age of 16 went to Goshen, where he became an apprentice at watchmaking with Daniel Wooden. He then took up the work of manufacturing silver spoons, and after becoming proficient in the watch, silver and jewelry trade, came to Middletown, which then had a population of less than 300. A few years after starting in business with a bench in a window, Col. Dusenberry moved to larger quarters and laid in a stock of clocks and watches. A short time later he purchased the lot upon North St., on which is now located the handsome block, part of which is occupied by his store. The first building, which he erected, was a two-story frame structure, but in 1882 this gave place to the edifice which now stands there. On March 1, 1893, Mr. Dusenberry took into partnership his son, D. Willis Dusenberry, under the present style, and continued in active business until 1906, when he retired from the active management of the concern, turning this over to his son.

Colonel Dusenberry is widely known throughout this section. He is a trustee of the Middletown Savings Bank, a director of the Middletown and Unionville and Water Cap Railroad Co.; president of the Board of Trade; director of the Orange County Trust and Safe Deposit Co.; director of the Middletown Straw Hat Works, and director of the old Middletown National Bank. He was also one of the active movers in securing the location of the Middletown State Hospital of this city.

Death of Albert Bornefeld.

SARATOGA, N. Y., March 9.—Albert Bornefeld, one of Saratoga Springs' oldest jewelers, died on Saturday, aged 73 years. Deceased was a native of Frankfort, Germany, and he located in Saratoga Springs 40 years ago. He was engaged in business continuously up to the time of his death. His store was at 346 Broadway.

Mr. Bornefeld is survived by his widow and one son, Albert J. Bornefeld.

Market Price for Silver Bars.

The following are the quotations of silver bars in London and New York, as reported by Zimmermann & Forshay:

	London.	New York
March 3.....	25 9-16d.	87 1/2
" 4.....	25 1-2d.	87 1/2
" 5.....	25 7-16d.	87 1/2
" 6.....	25 9-16d.	87 1/2
" 7.....	25 5-8d.	87 1/2
" 9.....	25 9-16d.	87 1/2

Harry T. Love, Brookville, is about to enlarge his jewelry store.

TRY US ON DIAMONDS

Lissauer & Company IMPORTERS

52-54 MAIDEN LANE, NEW YORK



580.

FLOWER EFFECTS

OUR

Chrysanthemum Brooches

are sellers. The secret is price—\$18.50 up. Well made, too.

CROSSMAN COMPANY, 3 Maiden Lane, N. Y.

William G. Morstrom & Co.

DIAMOND IMPORTERS and MANUFACTURING JEWELERS

Memorandum Packages of Loose or Mounted Stones on request. We solicit Special Order Work.

78-80 STATE STREET

CHICAGO, ILL.

Chas. A. Weber, Bankrupt Jeweler, Convicted of Larceny on Charges by Creditors.

The trial of Charles A. Weber, formerly diamond broker at 320 Fifth Ave., New York, who was held for the Grand Jury on the charge of the larceny of a pearl necklace, valued at \$6,500, from Ludeke & Heiser, 170 Broadway, New York, in the Fall of 1906, was begun before Judge Crain in Part III. of General Sessions last Thursday and a verdict of guilty was rendered yesterday.

According to the charge, Mr. Weber obtained a pearl necklace from the firm of Ludeke & Heiser, with whom he had been doing business for some time, and pawned it for \$2,000. It was later recovered by the firm, who obtained the pawn ticket from the receiver in bankruptcy after Mr. Weber failed. The trial opened with a review of the charge against the defendant by Assistant District Attorney Hart, in which he placed before the jury the statements the people wished to prove.

John Heiser, of the complainant firm, was called as a witness and testified that he received a telephone communication from the defendant to the effect that he wished to get a pearl necklace valued at \$7,800 for a customer, but this necklace was not in stock at the time and one valued at \$6,500 was delivered on memorandum to Frank Weber, a brother of the defendant, to be taken to the defendant.

Adolph Ludeke testified that he was in Maine at the time of the transaction and knew nothing about it until he returned. He said he failed to collect the money on the necklace or to get the necklace back after asking Mr. Weber for reports on it, and that he later had the defendant arrested.

Arthur B. Tuttle, a clerk employed by the firm, corroborated the testimony of Mr. Heiser as to the transaction and swore that the necklace was taken on memorandum. Frank Weber was called and testified to getting the necklace from the firm and delivering it to his brother.

Mr. Keim, Weber's receiver in bankruptcy, testified relative to the bankruptcy proceedings and the pawn tickets offered in evidence. George A. Fuller, a Pinkerton detective, testified relative to his search for Weber and of the arrest of the defendant at Port Jervis.

Chas. A. Weber, the defendant, then took the stand in his own behalf and testified relative to his business transactions. He then told of the telephone conversation already referred to and said the transaction did not differ in any way from other transactions with the firm. He admitted pawning the necklace and said he did not tell Ludeke & Heiser that he had pawned it, giving as a reason that he considered he had a right to pawn it, as it was his. He said that he didn't get the necklace on memorandum, but also said he did not know the difference between a memorandum sale and an ordinary sale. He said he received the necklace with a paper accompanying it.

Asked about his departure from New York about the time of the bankruptcy proceedings, he said he went to his old home and then related the incidents of his arrest.

The question as to whether the necklace

was taken on memorandum and remained the property of Ludeke & Heiser until paid for or whether, when the necklace was delivered to Mr. Weber, he bought it in ordinary sale, was a matter of contention between counsel and the District Attorney.

The defendant admitted that he pawned the necklace soon after receiving it. It appears that the necklace was not the only thing pawned and that goods obtained from other firms were also pawned.

Witnesses were called to prove the honesty and good character of the defendant prior to the time of the trouble and they all testified favorably to the accused.

The jury rendered a verdict of guilty, recommending mercy. He will be sentenced Friday.

Death of John A. Keane.

John A. Keane, for 25 years a salesman in the employ of the Ostby & Barton Co., 13 Maiden Lane, New York, and one of the best-known traveling men in the trade, died at his home, 500 Van Buren St., Brooklyn,



THE LATE JOHN A. KEANE.

N. Y., last Friday. He was sick only three days, and his sudden death came as a shock to his many friends and acquaintances in the trade. He contracted a cold which developed into pneumonia, and this affected his heart.

Mr. Keane was born Sept. 23, 1861, in Brooklyn, where he spent his early life. When a boy he was employed by W. R. Richards, Providence, R. I., and later came to New York and entered the employ of Ostby & Barton, now the Ostby & Barton Co., with whom he was connected at the time of his death.

It is said by those who knew Mr. Keane that he was a kind friend and ever ready to extend a helping hand in time of need. He was a most efficient salesman, and during his career on the road formed a wide circle of friends, who extend sympathy to the widow and children of the deceased.

Deceased was interested in athletic sports and especially in the game of baseball. He was a member of Ridgewood Lodge F. & A. M.; of the Elks, and was also a member of the Jewelers League and of the Brotherhood of Traveling Jewelers.

Funeral services were held from his late home Monday night. A widow and five children survive him.

Test Case to Determine Government's Claim to 10 Per Cent. Duty on Split Miners' Diamonds.

A customs controversy has arisen between the Government and importers over the importation of so-called "miners' diamonds," which are used extensively in the construction of rock drills, etc. For years it has been the practice of the Treasury Department to admit the diamonds free of duty under the provision of the tariff for "miners' diamonds not set." The Government now comes forward with the contention that the diamonds are advanced in value by splitting or cutting, and that they should be classified under a paragraph which specifies that duty be imposed at 10 per cent.

In order to determine the correctness of the Government's action in returning these stones for duty a test case has been brought by the Sullivan Machinery Co., of Chicago. The diamonds are worth from \$70 to \$100 a carat, and should the court sustain the Treasury Department in the contention which has been brought forward it will mean a considerable sum of money in added duties which will go to the Government. It is the contention of the Government that since the diamonds are not imported in the rough state they are advanced in value over the crude material, and are, therefore, dutiable at 10 per cent.

A large percentage of dealers in this kind of material have facilities for splitting the diamonds in their own factories and import the material in the crude form. The diamonds are technically known as carbonado, and those under protest are from two to three carats in weight, about the size of a small bean, and of a reddish color. The test case is before United States General Appraiser Sharretts, who has granted an adjournment until March 13 in order to enable the Treasury Department's counsel to produce witnesses to substantiate the 10 per cent. duty. The paragraph under the tariff laws on which this contention is raised, reads as follows:

"Diamonds and other precious stones, rough or uncut, and not advanced in condition or value from their natural state by cleaving, splitting, cutting or other processes, per cent. duty. The paragraph under which this contention is raised reads as follows:

The Government contends that since the stones have been split their value has been advanced and that this classification does not hold good.

Jewelers' Gold Bars Withdrawn and Exchanged at New York.

Week Ended March 7, 1908.

The U. S. Assay Office reports:
Gold bars exchanged for gold coin...\$287,946.66
Gold bars paid depositors..... \$31,819.57

Total	\$319,766.23
Of this the gold bars exchanged for gold coin are reported as follows:	
March 2	\$50,465.41
" 3	56,345.44
" 4	47,017.92
" 5	87,893.51
" 6	40,213.54
" 7	5,010.84
Total	\$287,946.66

"ASK YOUR JOBBER"

**The
Heavy Shanks**

COUPLED WITH
SUPERIOR WORKMAN-
SHIP AND UP-TO-DATE
IDEAS ARE WHAT
INDIVIDUALIZE THE

UR RINGS

The Untermeyer-Robbins Co.

Seventy-One Nassau Street, New York

A. ROSEMAN, 9-11-13 Maiden Lane, New York

IMPORTER OF

DIAMONDS

Maker of Diamond Jewelry



Established 1872

HEADQUARTERS FOR

**AMERICAN
WATCHES**

VARISCITE SOHN & HYMAN

Sole Agents

47-49 MAIDEN LANE
NEW YORK

The Newest Stone for High Class Jewelry



C. C. Purty has opened a jewelry store in Johnstown, Colo.

Thomas McLane has decided to open a store in Shubert, Nebr.

Chas. P. Elliott is about to engage in business at Cresbad, S. Dak.

R. M. Herr will soon open a retail jewelry store in Ontonagon, Mich.

A. Outram has opened a store in the Schmidt building, at Tracy, Cal.

Mr. Hanna intends to open a store in Pierre, S. Dak., in the near future.

W. G. Love is fitting up a store in the Nevada building, Angels Camp, Cal.

W. C. Shimmel is making arrangements to open a new store at Portersville, Cal.

E. E. Smith has opened a store of his own at 514 Washington St., St. Louis, Mo.

Taylor & Co. opened a retail jewelry store at 11 S. 9th St., Philadelphia, Pa., last week.

Al. Winter, River Falls, Wis., has commenced business in Spring Valley, in the same State.

Geo. W. Schaeffer has started in business on his own account at 320 W. Greenwich St., Reading, Pa.

The Kleine Optical Co. was recently incorporated in St. Louis, Mo. The incorporators are: Wm. C. Tieman, Woodlief Thomas and Nelson Thomas.

Oliver Watts, formerly in the employ of Elias H. Klahr, Middletown, Pa., has purchased a store at Millersburg, Pa., which he will conduct on his own account.

Articles of incorporation were filed last week with the Secretary of State at Jefferson City, Mo., by the Blankenmeister-Oberting Jewelry Co. The incorporators are A. L. Blankenmeister, George Oberting and A. F. Blankenmeister, 100 shares each. The capital stock is \$30,000, fully paid.

H. J. Webb will open a store in Springfield, Mass., about the middle of April. He will be located in room 4 on the second floor of the Republican building. Mr. Webb was formerly with Woods & Co., and for nine years conducted business under the name of H. J. Webb & Co., on Main St., Springfield.

T. B. Hightower, who was arrested in the store of W. L. Davids, Troy, Ala., in September, 1906, and searched in an endeavor to find a roll of chains that were lost, recently brought suit against the jeweler and was awarded \$750 damages on his claim for false arrest.

Creditors of Henry Muenchenberger, who had a jewelry store on De Kalb Street, near Main, Norristown, Pa., recently filed a petition to have him adjudged an involuntary bankrupt. The petitioning creditors are: Andrew Muenchenberger, \$758; Egbert & Groff, \$4, and the Times Publishing Co., \$12. Mr. Muenchenberger started in business in November, 1895.

Fight Over Railroad Watch Inspection Bill Now In the Maryland Legislature.

ANNAPOLIS, Md., March 4.—The fight is on in the State Legislature over the bill to regulate railroad watch inspection, which was introduced a short time ago in the House of Delegates on behalf, so it is said, of the American National Retail Jewelers' Association. This bill is practically identical with the measure introduced in the Illinois Legislature, which has been allowed to die by that body.

The text of the Illinois bill was published in full in THE CIRCULAR-WEEKLY of Nov. 6, 1907, and the bill introduced in this State differs from it only in minor particulars—for instance, in providing the standard of watches to be carried by railroad men it omits the limitation to 16 and 18 sizes, which appeared in the Illinois bill, and provides for monthly and semi-annual inspection instead of bi-weekly and quarterly, as in the other bill. The last section (6) provides that any railroad company superintendent, chief or general inspector who shall violate the act may be punished by a fine of not less than \$500 and not more than \$2,000.

The measure which was introduced by Mr. Gill by request bears title: "An act to require railroad companies to establish and maintain a department of time inspection, to require certain of their employes to carry standard watches and to provide for their regulation and inspection." It was put into the hands of the Committee on Corporations.

The same reasons for the introduction of the bill, i.e., to eliminate abuses in watch inspection, was given in the Legislature here as before the Illinois Legislature, all of which have been specifically denied by C. C. Crooks, the local inspector of the B. & O., Western Maryland Railroad, M. & P., and other lines.

Hearing on Optometry Bill Before Legislature of Ohio.

COLUMBUS, March 9.—The Senate Committee, to which was referred the Optometry bill introduced in the Legislature by request of the Ohio Optical Association, gave a public hearing last Tuesday night, and the meeting developed that the opticians of Ohio have come near being caught as buffers between the oculists and the practicing physicians of Ohio. The bill as finally agreed upon by oculists and opticians prevents practicing physicians from fitting glasses, and it appeared very much as though the oculists would like to have this made into law, but that they do not want to be credited with being behind such a measure. At least that is the way it looks to some of the opticians.

There was opposition—spirited opposition—from physicians at the hearing. It was intimated, and intimated so broadly, that the opticians alone were responsible for the drawing of the bill in such a manner as to prevent physicians from fitting glasses, that Judge Okey, attorney for the Ohio association, arose to publicly deny to the committee that such was the case.

The attendance at the committee meeting was large, as there were a large number of physicians in the city to attend the Repub-

lican convention. Another meeting will be held to-morrow night.

Annual Report of the International Silver Co. Made Public.

The International Silver Co. last week issued its report for the year ended Dec. 31, 1907. The income account compares as follows:

	1907.	1906.
Earnings	\$933,291	\$1,338,156
Interest on bonds.....	327,945	330,797
Balance	\$805,348	\$1,007,859
Preferred dividends.....	460,817	263,324
Balance	*\$144,529	\$744,035
Written off—		
Depreciation	205,318
Plant investment	400,000
Total written off..	\$605,316
Surplus	\$144,529	\$138,719
Previous surplus.....	2,902,377	2,763,658
Profit and loss surplus....	\$3,046,906	\$2,902,377

*Equal to 1.15 per cent. on the \$9,944,700 common stock outstanding.

The general balance sheet as of Dec. 31, 1907, compares as follows:

ASSETS.		
	1907.	1906.
Plant investment	\$15,444,691	\$15,342,934
Stock on hand.....	3,550,171	3,815,157
Other investments	4,340,966	4,283,931
First mortgage bonds in trust	88,719	125,719
Debenture bonds in treasury	60,000
Cash	588,309	603,460
Accounts and notes receivable	2,293,615	2,326,742
Total	\$26,361,471	\$26,497,943
LIABILITIES.		
Preferred stock	\$6,607,500	\$6,607,500
Common stock.....	9,944,700	9,944,700
First mortgage bonds.....	3,579,000	3,639,000
Debenture bonds.....	2,000,000	2,000,000
First mortgage bonds H. & E. Sil.....	127,600	127,600
Accounts and notes payable	957,018	1,087,119
Dividends, preferred stock.....	98,746	65,831
Reserve	123,816
Surplus	3,046,907	2,902,377
Total	\$26,361,471	\$26,497,943

Games Rolled by the Jewelers' Bowling League of New York.

The following were the scores of the teams of the Jewelers' Bowling League in the games rolled last week:

March 2.—Cross & Beguelin.....	832	830	856
vs. Julius King Optical Co.....	689	732	668
March 3.—Tiffany & Co.....	830	836	994
vs. L. E. Waterman Co.....	837	879	718
March 4.—Cooper Diamond Co.....	793	941	816
vs. Aikin-Lambert Co.....	797	799	821
March 5.—H. W. Wheeler & Co....	820	748	835
vs. A. A. Webster & Co.....	850	818	806
March 6.—Cross & Beguelin.....	810	917	867
vs. H. W. Wheeler & Co.....	696	758	610

STANDING OF TEAMS.

	Won.	Lost.	High score.	Per cent.
Cross & Beguelin.....	41	13	1,017	.759
N. H. White & Co.....	38	13	1,014	.745
Cooper Diamond Co.....	36	21	1,022	.632
Tiffany & Co.....	32	22	994	.593
Aikin-Lambert Co.	30	24	967	.555
C. F. Wood & Co.....	25	14	943	.510
Jos. Fahys & Co.....	27	27	951	.500
A. A. Webster & Co.....	19	35	916	.352
H. W. Wheeler & Co.....	12	36	922	.250
Julius King Optical Co....	10	38	889	.208
L. E. Waterman Co.....	9	36	879	.200

Mrs. C. L. Clarke, Connellsville, Pa., has decided to close out his stock at auction. The business will be discontinued about April 1.

Bankruptcy Referee Sustains Charges of Creditors Who Object to Joseph Haskell's Discharge.

Referee-in-Bankruptcy John J. Townsend has filed his report to the United States District Court of New York and has sustained the charges filed by Ingomar Goldsmith & Co. in the bankruptcy proceedings against Joseph Haskell, a former Maiden Lane jeweler, sustaining the claim of the creditors that Haskell has violated the provisions of the bankruptcy law and is not entitled to a discharge in bankruptcy.

The fight against Haskell by Ingomar Goldsmith & Co., through their attorney, Felix H. Levy, has been recorded in detail in these columns from time to time in the past two years. As was noted a year ago, charges were filed on behalf of the Goldsmith firm by Mr. Levy with the Referee in February, 1906, to the effect that the bankrupt had, with intent to conceal his financial condition, destroyed, concealed and failed to keep books of account or record from which his condition might be ascertained, and also that he had concealed the cash proceeds of a large quantity of merchandise sold by him.

Testimony in these proceedings was taken at length and Referee Townsend, in his report, reviews the testimony in detail and concludes that the first specification has been established by the evidence adduced. With regard to the concealment of assets he makes no specific finding, having sustained the first charge, but files with his report the testimony and briefs of the attorney for the information of the court.

It will be remembered that an involuntary petition was filed against Haskell in October, 1904, and the bankruptcy proceedings have been going on ever since. Ingomar Goldsmith & Co. also began a civil suit against him in behalf of the creditors, under which an order of arrest was issued, but this was set aside and Haskell recently started a suit for damages.

Officers Re-elected at Annual Meeting of the Jewelers' Protective Union.

The annual meeting of the Jewelers' Protective Union was held at the rooms of the Jewelers Board of Trade, 170 Broadway, N. Y., Tuesday afternoon, March 3, at which time the officers of the organization were re-elected for the ensuing year.

The meeting was called to order by President O. G. Fessenden and, after the report of Ira Goddard, the secretary and treasurer, was read and accepted, the report of the executive committee was approved. The reports showed the organization to have gained 41 new members since the last annual meeting.

The following officers were re-elected: President, Oliver G. Fessenden; vice-president, Frederick H. Larter; secretary and treasurer, Ira Goddard; assistant secretary and treasurer, Fred L. Goddard. The executive committee is composed of the president, vice-president, secretary and the following: August Oppenheimer, Leopold Stern, Charles F. Wood, George W. Street, Charles G. Alford, Augustus K. Sloan, William T. Gough and William I. Rosenfeld.

S. Terpstra, Hospers, Ia., was burned out, recently.

EICHBERG & CO.,

IMPORTERS AND CUTTERS OF

DIAMONDS,

65 NASSAU STREET, (Prescott Building.) NEW YORK.

HIMALAYA MINING COMPANY

MINERS AND CUTTERS OF
PRECIOUS AND SEMI-PRECIOUS STONES

537 FIFTH AVENUE
NEW YORK

LONDON
PARIS

OBERSTEIN
PROVIDENCE

"Gems and Precious Stones"

Their CHARACTERISTICS, LOCALITIES OF PRODUCTION,
TESTS and some CURRENT LITERATURE

A New Book on a New Plan. Tabulated, Concise, Authoritative.
A Handy Manual for Every Jeweler.

— Cloth, Postpaid, \$1.00 —

PUBLISHED BY

THE JEWELERS' CIRCULAR PUBLISHING CO., 11 John St., New York

Insure Your Life

L. A. Miller

Special Agent of the

Equitable Life Assurance Society

will show to any who may be interested Sample Annual dividend policies on the

LIFE, LIMITED PAYMENT, ENDOWMENT, and TERM PLAN

ADDRESS

L. A. Miller

Special Agent

180 Broadway, N. Y.

Gems and Precious Stones

Cloth, Postpaid, \$1.00. Published by the Jewelers' Circular Pub. Co., 11 John St., New York.



JOHN F. TURNER Expert Jewelry Auctioneer

2 Maiden Lane, New York, N. Y.

The following leading and representative firms, for whom I have conducted successful sales, will inform you what I have done for them. I can do the same for you.

James D. Murphy, New York, N. Y.	Frankfort Jewelry Co., Norfolk, Va.	Breen & Morris, Attys., Ft. Wayne, Ind.
J. E. Steere, Charlotte, N. C.	J. P. Morgan Co., St. Louis, Mo.	Dorcen Bros. & Co., Montreal, Canada.
George Wolf & Co., Louisville, Ky.	C. G. Schulze, Halifax, N. S.	Otto H. Fasoldt, Albany, N. Y.
S. N. Jenkins & Co., Richmond, Ind.	Frank Curtis Company, Decatur, Ill.	C. A. Sterner, Allentown, Pa.
G. Heitkemper, Portland, Oregon.	C. H. Knights & Co., Chicago, Ill.	Wm. Vogel, New Britain, Conn.
Morris G. Cohen, Pittsburg, Pa.	Ernst Schall Co., Hartford, Conn.	McConahay Co., Salt Lake City, Utah.
Jaccard Jewelry Co., Kansas City, Mo.	J. K. Basaye, Seattle, Wash.	S. Kitani, Cleveland, Ohio.
C. W. Ernsting, San Diego, Cal.	Thos. J. Routledge, Elmira, N. Y.	G. C. Bowen, Niagara Falls, N. Y.
E. A. Souder, Albany, N. Y.	T. Porte & Co., Grand Forks, N. Dak.	Anderson & Co., Ishpeming, Mich.
M. Henriksen, Duluth, Minn.	B. A. Southerland, Charlotte, N. C.	C. C. Thoma, Battle Creek, Mich.
Wm. V. Blair, Meriden, Conn.	Lord Bros. & Co., Milwaukee, Wis.	
C. O. Haines, Columbus, Ohio.		



W. H. SAART
President



GEO. J. KELLEY
Treasurer



F. B. PLATT
New York Representative



F. R. TRUELL
Western Representative

The Four Men who Have Been Instrumental in Making THE W. H. SAART CO.

ATTLEBORO, MASS.

The Leading Sterling Silver Novelty House in the United States

Bags Buckles Sash Pins Vanity Cases Hat Pins

The Simplicity Collar Supporter

A practical and ornamental novelty. Only one pin to fasten. The stiff bar acts as a support to the Gibson collars now so extensively worn, and conceals the two ends where they come together. All sizes. Neat and convenient. Look for our trade mark and accept no others. **BIG SELLERS.**

MILLER, FULLER & WHITING CO.
MANUFACTURING JEWELERS



VEIL, CUFF AND BABY
PINS, CAMEOS

SWASTIKA Buckles, Brace-
lets, Buttons, Charms,
Brooches, Barrettes, Combs,
Hat Pins, Scarf Pins,
Leather Trimmings.

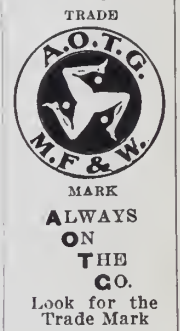

NORTH ATTLEBORO, MASS.

New York Office 9-11 Maiden Lane Samples only. We Sell to the Jobbing Trade Only

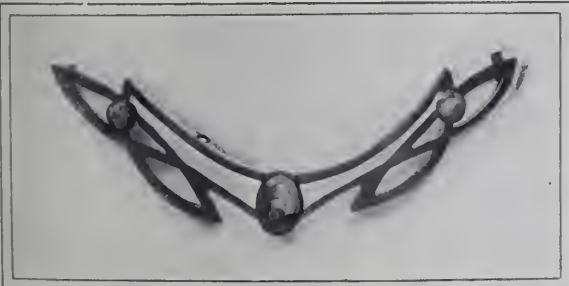

Women of fashion at present are wearing ornaments for the hair more than ever. We anticipated such a demand for these goods and have on hand a large assortment of Rhinestone, Coral and Jet

BARRETTES

from which to select. We also have a magnificent line of Coral Hat Pins, embodying many catchy designs, exclusive carvings and filigree effects, ranging in price from \$4.00 to \$15.00 per dozen.

SELECTION PACKAGES SENT UPON REQUEST

M. GUGENHEIM, Importer of

Brooches, Festoon Chains, Combs, Hat Pins, Collars, Jet Goods, Mesh Bags, in German Silver, Gilt Metal and Sterling

NEW YORK OFFICE: 33 Union Square, Decker Building

PARIS: 32 Faubourg Poissoniere



Made for St. Luke's Church,
Marletta, Ohio.

EASTER, the most important feast day of the Church, will soon be here. This day is made the occasion for presentation to Churches in all denominations, of memorial and other gifts of great variety. The Gorham Company are manufacturers of Church metal work in all its branches, viz.: Communion Sets, Altar Brasses, Alms Basins, Chalices, Ciboria, Monstrances, Memorial Tablets, etc., and they take this means of suggesting to the trade that their wants in this line be made known to the Company at an early date, to obviate the possibility of disappointment as to date of delivery.

Literature illustrating this line may be had upon application, and The Gorham Company hold themselves in readiness to lend all assistance in their power toward securing orders.

THE GORHAM COMPANY,

Silversmiths and Goldsmiths

Fifth Avenue and 36th Street, New York.

BRANCHES:

CHICAGO,
137 Wabash Ave.

NEW YORK,
23 Maiden Lane.

SAN FRANCISCO,
Temporary Office:
1103 Broadway, Oakland, Cal.

LONDON,
Ely Place.

WORKS: Providence and New York.

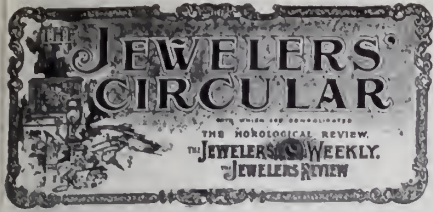

PUBLISHED EVERY WEDNESDAY BY
THE JEWELERS' CIRCULAR PUB'G CO.
 L. J. Mulford, Pres. & Treas. V. S. Mulford, V. P. & Sec.
 11 JOHN ST., COR BROADWAY, NEW YORK.
 TELEPHONE: CABLE ADDRESS:
 1148 CORTLANDT. JEWELAR, NEW YORK.

VOL. LVI. MARCH 11, 1908. No. 6.

Subscription in United States and Mexico, \$2.00
 Dominion of Canada, 3.00
 Other Countries in Postal Union, 6.00
 Single Copies, .10

Remit by check or money order. Remittances in money are at sender's risk.

Index to News and Special Articles.

	Page.
Silver Nef Presented to Manager of a German Steamship Company. Illustrated on Front cover	
Some Fine Examples of the Art of Munich Silversmiths	35
Recent Decisions on Jewelry and Kindred Lines	35
The Occult in Gems and Jewelry—(Concluded)	37
Repoussé Work and Chasing—(Continued)	39
The News From London	41
Examination of Adolph L. Hodcs in Bankruptcy	41
The Career of the Late August Schnell	43
Hjalmar S. Anderson Goes Into Bankruptcy. Jewelry, etc., Exported From New York	43
Death of George O. Street	43
THE CIRCULAR-WEEKLY'S State Stamping Law Passes Assembly of New Jersey	45
Importations at New York	45
Watch Case Bill Explained	47
Gem Importers to Fight Attempt to Collect 50 Per Cent. Duty on Manufactures of Agate, etc.	47
Examination in Bankruptcy of Jos. Brown & Co.	47
Elsie Bee's Fashions	48
Mayor of Milwaukee, Wis., Orders Destruction of Jewelers' Sign Clocks	49-51
Jewelry Firm Asks Police to Help Find Salesman Who Disappeared Feb. 25	51
Canada's Gold and Silver Marking Act Comes Into Operation March 13	51
Silver Market	52
Death of Albert Bornefeld	52
Col. D. C. Dusenberry, Middletown, N. Y., Celebrates 90th Birthday	52
Chas. A. Weber Convicted	53
Death of John A. Keane	53
Test Case to Determine Government Claim to 10 Per Cent. Duty On Split Miners' Diamonds	53
Gold Bars Exchanged at New York	53
New Enterprises	54
Railroad Watch Inspection Bill in Maryland	55
Hearing on Ohio Optomety Bill	55
Annual Report of the International Silver Co. Games Rolled by the Jewelers' Bowling League	55
Bankruptcy Referee Sustains Charges Against Joseph Haskell	55
Annual Meeting of the Jewelers' Protective Union	55
Bankruptcy Petition Against the Shourds-Adcock-Teufel Co.	67
Negotiations Between Premier Mining Co. and Diamond Syndicate for Renewal of Contract, Progressing	65
Patent Department	79-81
Treasurer of A. N. R. J. A. Against Proposed Railroad Watch Inspection Laws	81
Egyptian Goldsmiths	81
Synchronization of Clocks by Gas Pressure	83
Two Devices for the Rapid Winding of Watches	83
Results of Kew Trials for 1907-1908	85
Annual Trial of Chronometer Watches	87
The Jeweler's Appeal to the Farmer—(Concluded)	92
An Attractive Jewelry Emporium Down in Old Mexico	93
Timely Suggestions to Advertisers	93
The Lahor Market Cornered	93
Workshop Notes and Queries	95
A Novel Method of Utilizing Silver Scrap	95
Mexican Pottery Manufacture	97

COMMERCIAL failures during the month of February, according to statistics compiled by R. G. Dun & Co., though making a better showing than January, were largely in excess, both in number and liabilities, of the figures of the corresponding month of last year. The jewelry trade is no exception to the rule in this regard, the insolvencies reported among dealers in jewelry and clocks being 30 in number with liabilities of \$716,539, according to the table showing failures by branches of business compiled for *Dun's Review*. According to the same authority there were 15 failures in 1907, with liabilities of \$125,023; 10 in 1906, with liabilities of \$54,087; 20 in 1905, with liabilities of \$153,608, and 18 in 1904, with liabilities of \$188,721.

To Regulate Mark- THE jewelry trade, ing of Filled particularly the Watch Cases. manufacturers, jobbers and dealers in

watch cases, were distinctly interested last week in the bill to regulate the marking of filled watch cases which was introduced by Congressman Vreeland, Feb. 29, and published in full in the last issue of THE CIRCULAR-WEEKLY. This act, which essentially seeks to abolish the use of guarantees in watch cases that are shipped in interstate commerce, also provides for regulating the marking on gold filled, rolled plate or other watch cases, in a way that goes much further than the National Stamping Law passed last year.

According to the act a watch case made in whole or in part of inferior metal which bears a mark, usually employed to indicate the fineness of gold, must not only be stamped with the words "rolled gold plate," "gold electro plate," "gold filled," as the case may be, but must also have figures which indicate in decimal parts of an inch the thickness of the exterior and interior plates of gold upon the case. If the thickness of the interior and exterior differ, the figures of both must appear, a margin of one-half of one 1,000th of an inch being allowed for error. The word "exterior" in the act applies to all those parts of the case which are exposed to view and wear when the case is closed other than the crown, while the word "interior" applies to the inside surfaces of the back or lids and the inner and outer surfaces of the cap covering the movements. A violation of the act is made punishable by a fine of not more than \$500 and imprisonment of not more than three months.

The measure is not introduced as an amendment to the National Stamping Law, but as an act by itself, though it has incorporated in its provisions all those features of the stamping act which apply to gold-filled or gold-plated ware, with additional ones of its own which apply to watch cases only. It can stand or fall by itself without interfering with the stamping law at all, and will cause no conflict therewith.

The bill was framed at the request of several manufacturers, and is essentially designed to eradicate evils which have grown up in the watch trade from which legitimate manufacturers, jobbers and retailers as well as the public have suffered for many years. There was a condition to meet, in the view of the framers, and this

may properly be considered the first intelligent attempt to meet it by legislation of the kind proposed. It was stated at the time the bill was introduced that practically all the manufacturers had acquiesced in its provisions, but it seems that this is not exactly so, because, while the general purpose of the bill seems to be approved by all of them, some take exception to the phraseology as far as it applies to trade names such as "permanent," which they consider have assumed the value of trade-marks, and should be permitted to be used as such, though they are willing to abolish any stamp of guarantee. How the retailers and jobbers feel toward the bill has not yet been ascertained, though those behind the movement have been given assurances in many quarters that the bill meets with the dealers' approval, and an endeavor is now being made to get a definite expression of retail jewelers' views on the subject.

The experience with the National Stamping Law would indicate that if the bill is put in a form that meets with the entire approval of the legitimate members of the trade it will be seriously considered and quickly passed by Congress. If it has any defects or deficiencies that its sponsors have overlooked, these may be remedied by an honest expression of opinion from the members of the trade who can give the matter consideration. The fact that the bill is in the hands of the Hon. Edward B. Vreeland, who has the confidence and esteem of his fellow members of Congress, not only insures the measure the consideration that it deserves by the national legislature, but also gives assurance that the jewelry trade will have a "square deal" as far as the bill itself is concerned, and that proper and legitimate suggestions as to the measure itself will be given careful attention and consideration.

THE CIRCULAR-WEEKLY will be pleased to hear from its subscribers who have any comment to make upon the measure in any way, either as suggestions or simply as indorsements of the bill, that we may aid in determining exactly how the trade as a whole stands upon the subject, and also discover exactly how it will affect the retailer as well as the manufacturer.

A Strange Plan to THE strange suggestion that the Change British people of Great Britain should be made Time.

early risers by law has been dignified by a parliamentary bill which Mr. Pearce, M. P., has introduced into the House of Commons. Briefly the suggestion, which is that of a London builder, is that the hands of the clock should be put ahead 20 minutes on each of the first four Sundays in April so that the clock would, by this means, gain 80 minutes in the course of the month. Business hours would consequently, for example, start at 8.40 instead of 10 o'clock and finish at 3.40 p. m. instead of 5 o'clock, as reckoned by the mean sun, and as nothing is to be gained by advancing the clock on solar time the hands would be set back 20 minutes on each of the first four Sundays in September.

Very simple; but for all the big names which have given benediction to the scheme there are some who seriously question the

ROCK BOTTOM PRICES ON DIAMONDS

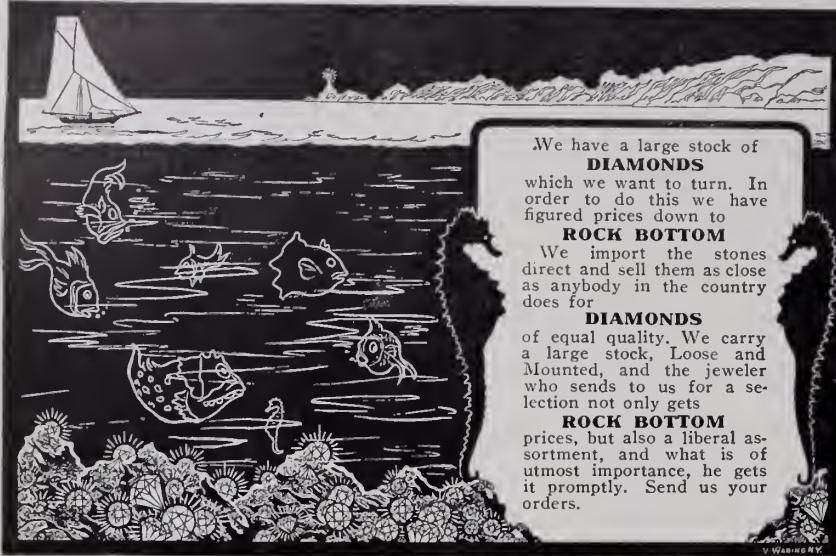

We have a large stock of
DIAMONDS
which we want to turn. In
order to do this we have
figured prices down to

ROCK BOTTOM
We import the stones
direct and sell them as close
as anybody in the country
does for

DIAMONDS
of equal quality. We carry
a large stock, Loose and
Mounted, and the jeweler
who sends to us for a se-
lection not only gets

ROCK BOTTOM
prices, but also a liberal as-
sortment, and what is of
utmost importance, he gets
it promptly. Send us your
orders.

CROSS & BEGUELIN

Importers and Cutters of Diamonds and Precious Stones

44 Rue de Meslay, PARIS

Telephone,
480 John

31 Maiden Lane, NEW YORK



The Silent Appeal

H. A. KIRBY

FINE
GOLD
JEWELRY

PROVIDENCE
NEW YORK

HAVE YOU EVER REFLECTED ON HOW A PRETTILY WROUGHT AND EFFECTIVELY DISPLAYED DESIGN WILL UNCONSCIOUSLY INFLUENCE A PURCHASE? HOW FIRST IT EXCITES ADMIRATION IN THE INDIFFERENT SPECTATOR, THEN IRRITATES THE DESIRE TO POSSESS, AND FINALLY BY ITS VERY IRRESISTIBILITY COMPELS HIM TO PURCHASE? IN EFFECTING SUCH A SALE, ONLY A FEW CONVENTIONAL REPRESENTATIONS ARE NECESSARY BY THE JEWELER, WHOSE PROFITS ARE A JUST REWARD FOR HIS SHREWDNESS IN EQUIPPING HIMSELF WITH SUCH JEWELRY. WE MAKE IT IN AN INEXHAUSTIBLE VARIETY—AT MODERATE COST.

suggested meddling with the clock. Regular living is, we are told, essential to good health, particularly in these strenuous days, and there are also night workers as well as day workers. Above all there is Greenwich, and having secured the recognition of the Greenwich meridian throughout the world shall the people of Great Britain be guilty of interfering with the established uniformity? The Astronomer Royal is against the scheme, for both the reasons stated, though the Irish Astronomer Royal is in favor of it. Most of the big employers of labor are also against the scheme, while the proprietors of theaters and music halls are by no means favorably disposed to it.

There is an old Spanish proverb which says: "Getting up very early in the morning does not make the dawn come any sooner." It might be asserted that we can neither cheat, rob nor kill Time. The old fellow is not to be humbugged by legerdemain or jugglery with the instruments wherewith we record his measured movement.

Boston.

George E. A. Phillips, of the Nelson H. Brown clock house, has been on a trip to New York.

George Moses, of the Thomas Long Co., has been on a recreation trip to Gloversville, N. Y., during the past week.

Samuel M. Magid is continuing the business of Cashner & Magid, 52 Cross St., under the old style, since its recent dissolution.

Arthur Reed, formerly salesman for Bigelow, Kennard & Co., is now with Thomas Long Co., and has charge of the gold jewelry department.

Morandi & Proctor, of Union St., who have bought out the culinary furnishings department of the Smith & Anthony Co., have added full lines of table silverware to their stock.

Buyers in town during the week included Henry Tisdale, Taunton; B. D. Loring, Plymouth; Joseph La Joie, Worcester; U. C. Smith, Brockton; Frank Schofield, St. Albans, Vt.

Nelson H. Brown will remove from 90 Franklin St. to larger and more convenient quarters on April 1, the entire second floor of the building at 70 Franklin St. being remodeled for the firm's occupancy.

Creditors in this city of J. F. Burgess, Camden, Me., have received an offer of settlement from him. He owes about \$4,000 on merchandise accounts and \$2,000 secured by mortgage. He expects to be able to raise \$1,000 cash, and pay 25 cents on the dollar.

J. A. Freund, of the Bigalke & Eckert Co., New York, will deliver a lecture this evening on "Adjusting Watches" before the New England Watchmakers' Club, at Room 11, Engineering building, Massachusetts Institute of Technology. The annual meeting of the club will be held March 18 at the club room, 17 Bromfield St., to elect officers and act upon a by-law amendment to make five members a quorum.

Three colored men were arrested, Feb 19, on suspicion of having taken part in the robbery of the Parsons Jewelry Store, at Fort Scott, Kans.

New York Notes.

George H. Cahoon, of the George H. Cahoon Co., Providence, R. I., spent a few days, last week, in this city.

M. H. Wallenstein, of Silbermann, Kohn & Wallenstein, sailed, March 3, on the *Kaiser Wilhelm II.*, where he will spend some time.

Alpin C. Chisholm and C. L. Rhodes, of the Bugbee & Niles Co., North Attleboro, Mass., spent Friday and Saturday in this city.

Erle R. Sheppard, manufacturers' agent, 51 Maiden Lane, has returned from a trip through the middle west and will remain in this city until April 15.

Everett L. Spencer, of the E. L. Spencer Co., Providence, R. I., has been spending a week in New York and vicinity. He went back to Florida Wednesday.

D. T. Marshon, of the Electrolytic Art Metal Co., who has been ill for the past week or more suffering from grippe and acute indigestion, is improving.

N. B. Barton, of the Ostby & Barton Co., 13 Maiden Lane, was in town Monday. He attended the funeral of the late John A. Keane, a former salesman of the firm.

Herman Kisselstein, a jewelry workman, hanged himself in the loft of a barn back of his home on Carpenter Ave., near Fulton St., Hollis, Queens, last Friday afternoon.

A fire occurred last Friday night in the building at 1212 Fulton St., Brooklyn, occupied by J. B. Hoecker as an optical establishment. The damage is estimated at \$1,000.

W. M. Birks, of Henry Birks & Sons, Ltd., Montreal, Que., visited the offices of THE CIRCULAR-WEEKLY, last week. He sailed for Europe on the *Mauretania* last Saturday.

Walter W. Ballou, Sr., accompanied by his son, W. B. Ballou, spent some time in New York last week. This is the elder Mr. Ballou's first visit to New York over two years.

Friends in the trade extend their sympathy to J. Ira Seebacher, with Henry Froehlich & Co., 68 Nassau, because of the death of Mr. Seebacher's mother, which occurred recently.

George C. Ferris, New York representative of R. Blackinton & Co., has just returned from a seven weeks' trip through the south and to the Pacific coast. He reports a very successful trip.

Isidor Lauchenbach, a diamond cutter, committed suicide Monday of last week by inhaling gas through a rubber tube at the home of his cousin, 217 E. 83d St. He had been out of work for some time.

H. C. and E. M. Bliss, of the Bliss Bros. Co., Attleboro, Mass., left Thursday on the *Alpache* for Sea Breeze, Fla., where they will spend a month's vacation, and will join their father and family there.

The Ten & Fourteen Karat Mfg. Co. has been incorporated under the laws of the State of New York, with a capital of \$50,000, to manufacture jewelry. The directors are: W. H. Reidell, Yonkers; Leon Kauffman and Wm. C. Little, New York.

H. A. Groes & Bro., 51 Maiden Lane, have been notified that they will have to vacate their retail store at 1503 Broadway

because the building is to be torn down. The firm have decided to discontinue their retail business, for the present at least, and will hold an auction sale of the stock. The auction will begin March 21.

The next regular monthly meeting of the Optometrical Society of the City of New York will be held this evening at 8 P. M., in the parlors of the Fifth Avenue Hotel, Fifth Ave. and 23d St. E. LeRoy Ryer will lecture on chapters five and six of Lockwood's Principles of Optometry. Professor Lockwood will conduct the quiz.

Fred I. Williams, who was at one time well known in the trade in this city as a jewelry salesman, died, Jan. 12, at St. Louis, of acute gastritis. He was employed by Albert Lorsch & Co. and by Bruhl Bros. in Providence, and later came to this city, and about 1890 became a jewelry broker, making his headquarters with C. Cottier & Son, 65 Nassau St. He left the trade a year later. He was 46 years of age.

John Ford, for 43 years proprietor of an optical store at 418 Pearl St., and one of the oldest men in the optical trade in this city, died last Thursday at his residence in Flatbush Ave., Brooklyn, at the age of 80 years. Mr. Ford's quaint old shop was a landmark in the neighborhood of Pearl and Chambers Sts. The personality of the proprietor and his aged assistant fitted well with one's first impression of the shop and, though his methods were of days gone by, he did not lack for customers.

At the Fifth Ave. salesrooms of the Gorham Co. there is on exhibition a window in American glass, which is of most artistic and careful workmanship. The subject is "Christ Walking on the Water," and shows a cloud-banked sky and the Apostles huddled in terror of the storm in an open boat. The background of purple and the green water form a strong contrast to the figure of the Saviour in His robes of white and red. The window was made from an original design and is to be placed in Grace Presbyterian Church, Brooklyn.

A meeting of the creditors of David Kessler, 226 Henry St., against whom a petition in bankruptcy was filed some time ago, was held at the office of Seaman Miller, referee in bankruptcy, at 2 Rector St., on Friday of last week, at which time the claims were presented. The creditors present could not agree on a trustee and the referee appointed the receiver in bankruptcy, William Scott, as trustee. The meeting was adjourned until March 18 at 2 P. M. In the schedule filed by Mr. Kessler the liabilities were set down as \$11,663, with assets of \$9,795.

Ruth Elizabeth Vorhis, daughter of Mr. and Mrs. Albert Barnes Vorhis, of Yonkers, N. Y., was married last Thursday to Frederick Mason Cook, of Whiting & Davis. Mr. Cook is well known and popular in the Maiden Lane district. The ceremony was solemnized at the home of the bride's parents, 261 S. Broadway, Yonkers, at 8.30 P. M. A large number of friends of the groom in the jewelry trade were present. A reception and dance followed the ceremony, at which about 150 were present. Mr. and Mrs. Cook are in the south on a trip and on their return will reside at Yonkers.

The election of officers of the Merchants' Association of New York for the current year occurred Thursday afternoon at a special meeting of the board of directors. By a unanimous vote the following were chosen officers of the association: Henry R. Towne, president Yale & Towne Mfg. Co., president; Gustav H. Schwab, of Oelrichs & Co., first vice-president; William A. Marble, vice-president R. & G. Corset Co., second vice-president; Wm. Jay Schieffelin, of Schieffelin & Co., third vice-president; Gustav Vintschger, president Markt & Co., Ltd., treasurer, and S. C. Mead, secretary. Resolutions expressing the commendation of the association of the work of the retiring president, Clarence Whitman, were adopted, resolutions approving of a bill introduced by Senator Beveridge and now pending before Congress were adopted, as were several other resolutions relative to land title registration and in regard to the movement for a special training school for United States Government appointees to the Diplomatic and Consular services.

The Seth Thomas Clock Co. has made a large tower clock for the Colgate Soap Co., of this city. The clock is said to be the largest in the world. It is now being thoroughly tested at the factory before it is brought to Jersey City and placed on the building of the soap company, facing the Hudson River. Some idea of the size of this clock can be gained from the following figures: The minute hand is 20 feet long and weighs 370 pounds. The point of the minute hand travels 23 inches in one minute, or three and two-thirds miles a week. The length of the hour hand is 15 feet, and its weight 500 pounds. It travels 81 feet eight inches in 24 hours. The dial is 40 feet six inches in diameter and is white with black numerals five feet long and 30 inches wide in the widest part. At night the clock hands and the numerals on the dial will be illuminated by incandescent lights. It will be easily possible to read the time from the New York side of the river. The clock is equipped with a gravity escapement with a compensating pendulum rod so arranged that the elements will have no effect on the accuracy of the clock.

Among the recent accessions at the Metropolitan Museum of Art are eight silver and bronze medals and plaques by Victor D. Brenner; a bronze medal, Pike's Peak Centennial, 1806-1906 (gift of Gardner Teall); pistol-handled silver knife and fork, English, 18th century (gift of Rutherford Stuyvesant); three pewter porringers, late 18th century; one pewter pitcher, 19th century; pair of brass egg-tongs, 19th century, American; two pairs of andirons, one door-knocker, one crane, and one andiron with crane, Italian, late 16th century; one large and one small relief head of George Washington, to be added to the Huntington Collection (gift of Mr. and Mrs. Frederick S. Wait); two statues in stone, French; Virgin Holding Child, 14th century, and Saint Barbara with Tower, 15th century; six terra-cotta reliefs of the Madonna Italian, 15th and 16th centuries, purchase. The list of loans include 42 bronze medals in commemoration of naval events in American history, early 19th

ESTABLISHED 1852

THE NASSAU BANK

Original Clearing House Member

Corner Nassau and Beekman Streets - - - NEW YORK

Title Guarantee and Trust Co.

176 Broadway (between John St. and Maiden Lane), New York

Capital and Surplus - - - \$12,000,000

Deposits received subject to Check. Interest allowed. Letters of Credit issued. Drafts drawn on Great Britain and the Continent. All Banking Facilities afforded to Customers. Accounts of Jewelers are especially solicited.

Finance Committee in Charge of Banking Interests

E. T. BEDFORD, 26 Broadway
 C. H. KELSEY, President
 E. L. MARSTON, of Blair & Co., Bankers
 W. H. NICHOLS, General Chemical Co.

CHARLES A. PEABODY, President Mutual Life Ins. Co.
 JACOB H. SCHIFF, of Kuhn, Loeb & Co.
 JAMES SPEYER, of Speyer & Co.
 E. O. STANLEY, 2d Vice-President

BRANCH BANKING OFFICES: 196 Montague St. and 175 Remsen St., Brooklyn; 350 Fulton St., Jamaica; 67 Jackson Ave., Long Island City

The Market and Fulton National Bank of New York.

ORGANIZED 1852

81-83 FULTON STREET.

Capital, \$1,000,000.

Surplus, \$1,500,000.

PROGRESSIVE — CONSERVATIVE — SUCCESSFUL.

ALEXANDER GILBERT, President.
 R. A. PARKER, - Vice-President.
 T. J. STEVENS - - - Cashier.
 JOHN H. CARR - Asst. Cashier.

Invites the Accounts of Jewelers.

Will extend every facility that good banking will justify

SAFE DEPOSIT VAULTS.

THE STATE BANK

376-378 GRAND STREET, NEW YORK

Capital and Earned Surplus, over \$1,500,000. Deposits over Fifteen Millions.

Offers a favorable market for short and long time jewelry and diamond paper.

The Mercantile National Bank

OF NEW YORK

WILLIS G. NASH, President

MILES M. O'BRIEN, Vice-President

WM. SKINNER, Vice-President

WILLIAM H. TAYLOR, Vice-President

EMIL KLEIN, Cashier

DIRECTORS

WILLIAM F. CARLTON,
ROBERT C. CLOWRY,
WILLIAM NELSON CROMWELL,
L. H. CUTTER,
EDWIN GOULD,
HAROLD A. HATCH,

EDWARD T. JEFFERY,
WILLIAM H. LAWS,
WILLIS G. NASH.
BENJAMIN NICOLL,
MILES M. O'BRIEN,
CHARLES E. PERKINS,

DICK S. RAMSAY,
WILLIAM SKINNER,
E. D. STREET,
WILLIAM H. TAYLOR,
E. J. TRUSSELL,
WARNER VAN NORDEN,

Strictly a Commercial Bank
Accounts Solicited

1851

The Jewelers' Bank for half a century
in the same location.

1908

The Chatham National Bank

OF NEW YORK

Broadway and John Street

CAPITAL - - - - - \$450,000
 EARNED SURPLUS - - - - - \$1,000,000

Accounts Solicited

DIRECTORS

GEORGE M. HARD, President
 JOHN H. WASHBURN, Retired
 SANFORD H. STEELE, Vice-President
 General Chemical Co.
 FRANK R. LAWRENCE, Attorney
 DANIEL J. CARROLL, Lumber

JOHN D. VERMEULE, President
 Goodyear India Rubber Glove Co.
 G. P. MOROSINI, Banker
 HENRY F. SHOEMAKER, Banker
 WILLIAM B. CONRAD, White Goods
 FRANKLIN S. JEROME,
 Treasurer U. S. Finishing Co.

FRANK J. HEANEY, Exporter
 SAMUEL WEIL, Capitalist
 LEWIS COON, Real Estate
 O. G. FESSENDEN,
 of Hayden W. Wheeler & Co.,
 Jewelers.

GEORGE M. HARD, President
 WILLIAM H. STRAWN, Cashier
 HENRY L. CADMUS, Assistant Cashier

TRADE



MARK.

Geo. O. Street & Sons

35 Maiden Lane, New York

Established 1837

RINGS

SLEEVE-LINKS

SCARF-PINS

FOBS AND SEALS



An Opportunity to Buy \$140,000 Worth of High Grade Diamond Jewelry at Low Figures

Being obliged to vacate our store at short notice, owing to the building being torn down, we have decided to discontinue our retail business and sell the same at auction, beginning March 25th.

INSPECTION INVITED

H. A. GROEN & BRO.

OFFICE AND FACTORY:
51 MAIDEN LANE

1503 Broadway, New York

New York Notes.

(Continued from page 61.)

entury, lent by Thomas Harbeck, and a silver mug, American, late 18th century, lent by Hon. Chas. H. Truax.

The William Dietz Co. has been incorporated under the laws of the State of New York to deal in silverware, etc., with a capital of \$10,000. The directors are: August Kutzleb and Walter Kutzleb, New York, and Richard Kutzleb, Baltimore, Md.

Word was received in New York yesterday that the Henry Welf Co., Cleveland, O., had made an assignment. The business was established some years ago by Henry Welf. In 1896 the stock and fixtures were purchased by a relative. In 1897 the business was incorporated.

Herman Hamburger, who formerly represented the Bonner Mfg. Co., has associated himself in a similar capacity with S. Pitzel, manufacturer of diamond mountings, 51 Maiden Lane. Mr. Hamburger's territory will include New York State, Pennsylvania and parts of Maryland and the District of Columbia.

Andrew Mander, a gold and silver plater, 79 Nassau St., died Saturday at his home, 1226 Pacific St., Brooklyn. He was born 48 years ago in this city, and for many years has been in business on Nassau St. Deceased is survived by two sons and a daughter. The funeral services were held from the late residence of the deceased Sunday night.

Last Week's New York Arrivals

THE CIRCULAR-WEEKLY each day posts in its office a bulletin of the latest buyers visiting New York, which every member of the trade is cordially invited to copy.

- ASHTABULA, O., M. E. Flour, Margaret Louise Home.
- BALTIMORE, MD., M. Schneeberger (Goldenberg Bros.), Breslin.
- CHICAGO, W. Lambrecht, Belvedere.
- CINCINNATI, O., Miss J. Marsh (H. & S. Pogue Co.), Imperial.
- INDIANAPOLIS, IND., W. D. Sanford (Pettis Dry Goods Co.), 2 Walker St.
- MINNEAPOLIS, MINN., C. E. Fisher (L. S. Donaldson Co.), 2 Walker St.
- H. G. Schoonmaker (L. S. Donaldson Co.), 2 Walker St.
- NEW HAVEN, CONN., E. F. McDermott (E. Malley Co.), Grand; 320 Church St.
- PORT HURON, MICH., J. D. Patterson (R. S. & J. D. Patterson), Navarre.
- PROVIDENCE, R. I., A. J. Ferguson (Callender, McAuslan & Troup Co.), 2 Walker St.
- ST. LOUIS, MO., J. F. Bolland (J. Bolland Jewelry Co.), Imperial.
- George Hess (Hess & Culbertson Jewelry Co.), Cumberland.
- TORONTO, ONT., W. E. Ellis, Park Ave.
- WASHINGTON, D. C., J. Hertzberg (S. Kann Sons & Co.), Cumberland.
- YOUNGSTOWN, O., S. G. Dixon (J. N. Euwer's Sons), Seville.

E. W. Dick, in the employ of Moses D. Brandes, Birmingham, Ala., has been held for trial charged with taking diamonds from the concern and pledging them in local pawnshops. Dick was arrested by officers Cole and Williams. Several valuable gems have been recovered.

Negotiations Between Premier Mining Co. and Diamond Syndicate for Renewal of Contract Progressing Favorably.

To set at rest the sensational reports published in the daily papers of this country and Canada to the effect that the contract between the Diamond Syndicate in London and the Premier Mining Co. would not be renewed, THE CIRCULAR-WEEKLY Monday cabled directly to the president of the Syndicate and the London representative of the Premier Mining Co., asking the true state of affairs. Yesterday cables were received from these gentlemen which show the falsity of many of the reports published, Mr. Abrahams, of the Diamond Syndicate, stating that the negotiations for a renewal of the contract are still pending, and Mr. Busch for the Premier company, stating that all parties are doing their best to come to an agreement.

The two cables read:

ture is under the auspices of the Newark Manufacturing Jewelers' Association, whose members will extend a welcome to every one interested who wishes to attend the lecture.

In speaking of the incorporation of the firm of Noble & Hunt, in last week's issue of THE CIRCULAR-WEEKLY, it should have been stated that the concern manufactures jewelers' and silversmiths' machinery. The incorporators are not jewelers and silversmiths, as the erroneous note signified.

News Gleanings.

Clinton H. Little, 85 E. Main St., Amsterdam, N. Y., has leased the building 27 Main St. The building will be entirely re-

297, CN: LONDON, 14.

**JEWELERS' CIRCULAR,
NEW YORK.**

**ALL PARTIES DOING THEIR BEST TO COME TO AN
ARRANGEMENT. BUSCH.**

JS. 19 LONDON, 11.

**JEWELERS' CIRCULAR,
NEW YORK.**

**NEGOTIATIONS PENDING BETWEEN PREMIER COM-
PANY AND THE SYNDICATE. ABRAHAMS.**

It will be seen from the above that most of the reports which have been given such wide publicity are not founded on fact, but are purely conjecture on the part of the writers.

Even if the contract were not renewed, which is now not at all likely, the Premier company any more than the De Beers companies could not afford, for its own interests, to reduce the prices on the stones, which is the crux of the whole diamond question. It was this community of interest in maintaining a standard price for diamonds that has caused them to act together.

Failure to renew their contracts, the Maiden Lane importers say, would not mean a war in prices, but simply a fight for trade, with the quality of the diamonds and not the price as the inducement for patronage.

Newark.

The firm of Schultz & Lapp has been incorporated with a capital of \$50,000. The incorporators are: Frederick L. Schultz, John C. Lapp and Edward G. George, all of this city.

The attention of the trade has been called to the meeting to be addressed by Prof. J. C. Monaghan in the Free Public Library, Saturday, March 14, at 8 p. m., on the subject of "Manual and Technical Training and Their Benefits to Those Engaged in the Making of Artistic Wares." The lec-

modeled and one-half will be occupied by Mr. Little's store.

On the claim of a St. Louis creditor a local constable recently took charge of the store of C. E. Oeth, Jefferson City, Mo. The claim was only about \$100, and an attempt will be made to adjust it at an early date. Mr. Oeth has been in business in Jefferson City about three years and carries a small stock.

Franklin Thomson, secretary of the Milwaukee Jewelers' Club, and of the Wisconsin Retail Jewelers' Association, says that the State convention in Milwaukee, in June, will be the largest ever held. Responses to notices have been unusually liberal. Mr. Thomson says the new optical society is building up rapidly.

According to the corporation reports of the Benedict Silverware Mfg. Co., East Syracuse, N. Y., the volume of business for the year ending March 1 was double that of the preceding 12 months. New machinery has been installed and about April 1 the company will add to its force of workmen. These officers have been elected: President, Harry L. Benedict; first vice-president, George N. Crouse; second vice-president, C. C. Graham; secretary, Chas. Von Wagner; treasurer, R. B. Roantree; assistant secretary, John Bailey; assistant treasurer, Newton Owens. Messrs. Benedict, Crouse and Von Wagner are the directors.

Providence.

George H. Holmes served on the jury last week.

George W. Peck, of the Miner & Peck Co., New Haven, was in town Wednesday.

Horace W. Steere, of Arnold & Steere, is enjoying a brief vacation in Bermuda. George F. Darling is also in that place.

A demand for sterling silver plate novelties has caused Mackey & Elias to work their factory overtime for the past two weeks.

H. F. Carpenter, of H. F. Carpenter & Son, gold refiners, and his wife, left Wednesday for an extended trip in the south and the Bermudas.

A new factory for the manufacture of mounted combs has been opened at 59 Page St. by J. W. Heller, formerly manager of the factory operated by A. Bazar & Co.

A. T. Wall, of A. T. Wall & Co., accompanied by his family, will be absent from this city for about six months. He sailed for Europe last week and will tour the Continent.

Fire caused considerable damage in the shop of H. J. Astle & Co., on Friendship St., Monday morning. The blaze started in the warehouse and spread to the store rooms of the concern.

Everett L. Spencer made a trip to his factory in this city last week. He returned Tuesday to Rockledge, Fla., where he has been spending the Winter. He will remain in the south until April.

Feintuch & Solinger, a new firm, are making preparations to make Oriental jewelry and combs at 234 Chestnut St. This is a new concern. Mr. Feintuch will represent the concern on the road.

A new concern which manufactures tools for the trade and spectacle frames, is headed by W. F. Keenan, formerly with the Stevens Optical Co. The concern will be known as the Solar Optical Co.

Benjamin Noka, a genuine full-blooded Narragansett Indian, was taken to the Rhode Island Hospital from a cheap lodging house early last week. Noka's last place of employment was in a jewelry shop.

R. G. Shultz, the foreign representative of the United Wire & Supply Co., celebrated the 25th anniversary of his marriage at his home, 31 Daboll St., Wednesday evening. A large number of friends attended, and the presents were numerous and costly.

After a brief hearing in the United States District Court before Judge Brown, last week, the Chase Mfg. Co. was adjudged bankrupt. The bankruptcy proceedings were involuntary and were brought on the petition of George W. Dover and others. The matter was placed in the hands of Chester W. Barrows as referee in bankruptcy.

The imports into the Port of Providence during the past week included some items which seem to reflect an indication that jewelry business is picking up. Among other things which arrived were four packages of imitation precious stones from Bremen, one package of metal, and one of jewelry from Liverpool, and one package of gold slag from Yarmouth.

Burglars entered the house at 501 Public St. occupied by Mrs. Ethel Cutler, mother

of Harry Cutler, president of the New England Manufacturing Jewelers and Silver-smiths' Association, March 3, while Mrs. Cutler was away, and stole a quantity of old coins and some jewelry which had a greater value than its intrinsic worth. Mr. Cutler was notified of the burglary, and he in turn reported it to the police of the Seventh station. The officers have no clue.

The Providence police have begun to take a census of the unemployed living in this city. The reports of the officers in precincts 1, 4, 5 and 7, the jewelry districts, will be interesting reading. The lists are incomplete as yet, but those figures which are in do not show that there is any alarming condition of affairs in jewelry circles. The estimate made by the police of stations 5 and 7, the precincts in which the bulk of jewelry workers live, are indicative of the fact that the majority of workers of this sort are still at work. In many cases they point out that the jewelry workers, while employed on a short-hour basis, are nevertheless earning some money each week, and cannot therefore be classified under the head of the unemployed.

The Union Trust Co.'s affairs have assumed a brighter aspect in the past two weeks, and it now appears that the bank will reopen. The reorganization plan, it is expected, will be accepted by the Superior Court when the receivers make their final report to the court next Saturday. Already over 95 per cent. of the depositors have released their claims against the bank and subscribed for stock in the new concern which the receivers propose, if the court is willing, to organize. Jewelers in this city and the Attleboros are keenly interested in this company. It has been stated that the reopening of this bank will do more to better conditions in the trade in this section than anything else which could occur. There are nearly 100 manufacturing jewelers on the deposit books, and their claims alone aggregate nearly \$2,000,000. William A. Copeland, a manufacturing jeweler, is chairman of the receivers' committee, and Harry Cutler is also a member of this committee.

Attleboro.

Peter Nerney, of the Bay State Optical Co., spent last week on a business and pleasure trip to the Panama Canal zone.

Frank Mossberg, of the Frank Mossberg Co., is an aspirant for place as alternate to the Republican district delegate to the national convention.

The W. A. Sturdy Mfg. Co., Sturdy Bros. and Freeman, Daughaday & Co., a group of three jewelry concerns in the nearby village of Chartley, resumed full time in their factories last week.

John W. Luther, of J. W. Luther & Co.; Ezekiel Blake, of the James E. Blake Co., and Fred W. Lincoln and John M. Fisher of J. M. Fisher & Co., were last week elected to office in the Methodist Church.

The Finberg Mfg. Co. last week began the erection of a steam power plant in the rear of its factory to supplant the electric power now used. Land has also been acquired for the erection of an addition to the factory property in the near future.

The annual report of Cummings & King

was filed last week with the Secretary of State, through Treasurer Charles Billington. The figures show: Promotion account, \$2,000; machinery, \$18,850; cash and debts receivable, \$75,511; manufactures and merchandise, \$26,721; advertisements in force, \$10,000; good will, \$10,000; commissions, \$35,364; profit and loss, \$4,176; capital stock, \$138,990; accounts payable, \$26,994; floating debt, \$16,638.

The town's local election took place last week and the voters bestowed office on Fred L. Torrey, of F. L. Torrey & Son; Charles E. Bliss, formerly of Bliss Bros., and on several less prominent in the jewelry industry. The town voted thanks to Joseph L. Sweet, of the R. F. Simmons Co., for his generous donation toward the new public library. David E. Makepeace, of the D. E. Makepeace Co. is new chairman of the water commissioners. Maj. Everett S. Horton, of the Horton-Angell Co., was elected chairman of the library trustees for his 23d year.

Owing to the serious illness of Walter E. Hayward and the necessity of closing up his business, his conservator, Harold E. Sweet, appointed by the Probate Court, March 2, disposed of the entire business of Mr. Hayward, excepting the book accounts, to Charles C. Wilmarth, factory superintendent and foreman for Mr. Hayward for the past 21 years, and Frank J. Ryder, the traveling salesman for the firm since 1901, who will hereafter conduct the business under the name of the Walter E. Hayward Co. All outstanding accounts up to March 1 will be settled by the conservator, Mr. Sweet.

Joseph L. Sweet, of the R. F. Simmons Co., and Charles H. Tappan, of the D. F. Briggs Co., have proven the first to come to the relief of the unemployed in this town. They have contributed \$500 each toward a fund to provide aid to the needy. This is one of the results of the mass meeting of unemployed held here a few days ago, at which the fact was brought out that about 80 per cent. of those laid off at the jewelry factories because of dull times are Attleboro residents, many without reserve funds to meet the emergency, and scores are in actual want. The difficulty has been met by appointing a committee headed by Chas. O. Sweet, of C. O. Sweet, Son & Co., to find ways and means to aid these unfortunate jewelry workers and at the same time, if possible, save them from the stigma of pauperism. The committee was named at the mass meeting and has been actively at work since. The office of the selectmen has been designated as a free employment bureau from 10 to 12 each day, in charge of Selectman George M. Worrall. Lists of the unemployed are kept there so that as business becomes better the jewelry manufacturers hiring help can give preference to fellow townsmen. At the same time funds will be collected for relief outside that given by the overseers of the poor. Selectman George A. Sweeney and Truant Officer Warren Parker will assist in the distribution, which will be wholly of supplies, no cash being given out.

W. G. Riley, formerly of the firm of Riley Bros., Philippi, W. Va., has gone to Gary, Ind., where he has opened a new store.

North Attleboro.

Daniel Chisholm returned Friday from the west.

C. H. Schlicker, of Charles L. Trout & Co., was in town on business last Friday.

S. E. Coombs has returned from a New England trip for the Paye & Baker Mfg. Co.

William F. Maintien has been nominated for another year by the Republicans of Plainville.

E. I. Franklin & Co. worked full time last week. The Bugbee & Niles Co. lengthened out its schedule.

A dividend of 60 per cent. has been officially declared by Comptroller of the Currency Ridgely to the depositors of the defunct Jewelers' National Bank. It will be paid to depositors within 10 days.

The T. I. Smith Co. has filed the following report with the Commissioner of Corporations: Real estate, \$48,483; machinery, \$66,097; cash and debts receivable, \$136,597; manufactures and merchandise, \$50,000; total, \$301,127; capital stock, \$150,000; accounts payable, \$61,439; profit and loss, \$80,688; total, \$301,127.

Manufacturers have received letters urging their support and influence with Representatives and Senators in the question of furthering industrial education. It is desired that a bill be passed through the Legislature making an industrial education commission permanent. It was appointed for five years by Governor Douglas. It is also desired to have courses in industrial education introduced into the high schools. In towns having less population than 10,000 it is not possible to support a school, and therefore a course in the high school would be beneficial.

Frederic Mason Cook, Attleboro Falls, was married in Yonkers, N. Y., Thursday evening, to Miss Ruth Elizabeth Vorhis, daughter of Mr. and Mrs. Albert D. Vorhis, of that place. The ceremony was performed by Rev. William P. Bruce. The bridesmaids were Miss Marion Whiting, daughter of Charles A. Whiting, of Whiting & Davis; Miss Margaret Garrett, of Hamilton, Ont.; Miss Natalie Hamilton, of Brooklyn, and Miss Lucinda Vorhis, of Brooklyn. G. Percy Clap, New York representative of the Daggett & Clap Co., was best man. Harry W. Fisher, of Furbish, Swift & Fisher, was one of the ushers.

Harrisburg, Pa.

Harrisburg has lost out in its efforts to secure the Southern Watch Co. plant, which will be removed from Nashville, Tenn., to York, this State, in the near future, as told in another column.

O. H. Watts, Biddletown, has purchased the store of W. F. Day in Millersburg, this county, and took possession March 9. He had been with E. H. Klahr in Middletown for some years.

Charters have been granted to the J. D. Fowler Co., Thornhill, Allegheny County, with a capital of \$15,000 to deal in jewelry, dry goods, etc., and to the Natalie Store Co., of Natalie, with a capital of \$10,000.

The sale of the stock of D. Shapiro in Lykens, recently purchased by the Atlantic Mercantile Co. of Atlanta, Ga., was concluded March 10. B. Shapiro was severely

burned about the face and head a few days ago by a rush of gas from the furnace at his store while in the act of opening the furnace door.

Candidates for the Legislature of 1908-9 may as well prepare themselves for a statement of their position with respect to a number of measures affecting retail jewelers and other merchants, which will be introduced at the instance of the State Retail Merchants' Association next Winter. Among these measures which are to be introduced is the Garnishee bill, which proposes to give the right to the merchant to attach a certain percentage of a man's wages or salary to apply them on old accounts. The candidates for the Legislature will also be urged to favor the abolition of the mercantile license laws.

Savannah, Ga.

James H. Hunter, a silent partner in the firm of R. Van Keuren & Co., died, Feb. 29, of acute bronchitis, aged 52 years. He is survived by a widow, one daughter and one son.

Theus & Co. will furnish the challenge trophy, and R. Van Keuren & Co. will furnish the second and third prizes to be awarded in the automobile races to be held in Savannah, March 18 and 19. The challenge trophy is a Grecian-shaped two-handled silver cup on an ebony base, the whole to be 27 inches high. An oval frame containing the picture of General Oglethorpe is the central engraving. Beneath the picture is a shield with the words "Governor Oglethorpe," and a date upon it. Supporting the frame are palm branches, and live oaks covered with Spanish moss, all in bold relief. On one side of the frame is an Indian scene, representing life about Savannah in 1733. Wigwams, canoes, a stream, and a typical Indian camping scene complete the picture. In unusual contrast is the scene on the other side of the central engraving. Here are shown automobiles of latest design at racing speed, with the date "1908." The convoluted stem of the cup has acanthus leaves in relief. The face is Corinthian. The ebony pedestal is octagonal in shape. Cotton bales surround it, affording room for the inscription of the names of successful winners of the cup. The spread of the handles is 22½ inches. Leading from the decorated handles to the cup in relief are cotton plants with the white balls showing. The trophy is to cost about \$1,800. The second prize will be a silver cup, 15 inches high, of very graceful design. A picture of General Oglethorpe, showing the entire figure seated, will form the central decoration, the name "General Oglethorpe" being engraved beneath the figure, the picture to be bordered with leaves and wild roses. The third prize is very much like the second and each one costs about \$1,000. The winning drivers will each be given a bronze medal of very handsome design. All medals will be furnished by A. Van Keuren & Co.

A fire at Elmira, N. Y., recently, wrought considerable damage to the factory of the Majestic Cut Glass Co., at the corner of Madison Ave. and Clinton St., at that place.

Canada Notes.

E. M. Arnold, Kentville, N. S., has assigned.

The assets of David Spencer, Montreal, have been sold.

The assets of J. N. Brouillette, Montreal, have been sold.

W. W. Tyrill, St. Catharines, Ont., is asking an extension.

Wm. Hepinstall, Leamington, Ont., has sold out to G. E. Early.

James S. Jones, Colborne, Ont., has moved to Deseronto, Ont.

W. B. Saunders, Vancouver, B. C., is reducing his stock by an auction sale.

J. A. Caulder, Moose Jaw, Saskatchewan, has sold his retail business to A. Cunningham.

The death of H. Schaefer, of H. Schaefer & Son, Halifax, N. S., is announced.

The stock of S. Sherman, Montreal, has been damaged by fire. The loss is covered by insurance.

Out-of-town jewelers calling on the Toronto, Ont., trade, last week, included: P. S. Byrne, Beaverton; W. M. Ketchum, Brighton; N. Brock Wilkins, Galt; J. Auger, Mount Brydges, and F. Clarke, Peterborough—all Ontario.

The bracelet given by Miss Margaret Anglin, the famous actress, to the best actress in the Earl Grey Musical and Dramatic Competition at Ottawa, was engraved at the jewelry store of Henry Birks & Sons. It is a plain band of gold set with three large sapphires and two diamonds. The winner was Mrs. Edgar.

At the annual meeting of William A. Rogers, Ltd., held in Toronto, Feb. 27, the report of the directors showed earnings for 1907 greater than those of any previous year. The sales for the year aggregated \$1,395,965, and the net profits were \$195,649. Dividends of 7 per cent. on preferred, and 8 per cent. on common stock were paid, amounting to \$123,000, and \$25,000 transferred to the realty and plant reserve, making the total reserves \$400,000. The assets were stated at \$2,417,051.

E. M. Trowern, Toronto, Ont., secretary of the Retail Merchants' Association, of Canada, has been in Ottawa conferring with the Department of Justice relative to the draft of the new Gold and Silver Marks Act, to replace the measure submitted last season, to which numerous objections were taken by retail and wholesale jewelers. A bill has been drafted which will meet all the objections urged last year, and will be introduced to the Federal House. The English standard of nine karats for all marked goods has been adopted.

Thomas Lambert, who died recently at the home of his brother-in-law, North Attleboro, in the 61st year of his age, was at one time well known in the jewelry business. Mr. Lambert was formerly a member of the firm of Lambert & Schofield, manufacturers, who were first at Plainville and then at Providence, R. I., and while there Mr. Lambert retired. The business is now conducted by Schofield, Battey & Co. Mr. Lambert is survived by two sisters.

Pittsburg.

C. C. Marsh, whose illness has been reported from time to time, continues to hold his own.

Sol. Cerf, of Sol. Cerf & Co., is home from New York, where he had been buying stock for the Spring trade.

W. J. Johnston, of the W. J. Johnston Co., expects to spend a few days of this week in New York on business.

Many jewelers were temporarily scared last week by the report that there would be another flood, but fortunately the rivers did not reach the danger line.

West, White & Christy have as yet secured no trace of the man who robbed one of their traveling salesmen of a large amount of jewelry several months ago at Canton, O.

William Heeren, of Heeren Bros. & Co., has started on a tour of Egypt and other countries of the Old World. Otto Heeren, of the same firm, will leave early in May for a trip abroad.

J. C. Grogan, of J. C. Grogan & Co., has been in New York and Atlantic City for the last few weeks. The Grogan house, it is said, have re-leased their present place of business for another year.

L. W. Vilsack & Co. have taken possession of the new store which has been leased by the firm in Wood St. and have begun making extensive alterations to the building, which they expect to occupy April 1.

The following out-of-town merchants were in Pittsburg last week buying goods: L. Schmidt, Braddock; J. R. Thorn, Toronto; John Linnenbrink, Rochester; F. H. Hayes, Washington; E. A. Bloser, New Kensington.

M. A. Mead, of M. A. Mead & Co., Chicago, was in Pittsburg last Saturday, and spent the day with J. T. Montgomery, local manager of the house. Mr. Montgomery says that he is extremely optimistic on business conditions.

Three or four jewelry firms have been bidding for space in the new Keenan store building being erected at Liberty Ave. and 7th St., but it is stated that the prospective tenants have not been able to come to terms with the building people.

The fact that Harry Levinson, arrested in New York for larceny, had pleaded guilty was read by Pittsburg jewelers with a great deal of interest. There are several jewelers here who have been watching his movements closely. Levinson was formerly in business here.

S. Davis, of S. Davis & Co., was operated on in New York last week and the operation was successful. He has left there for Markleton Sanitarium, where he will rest for the next three weeks. Mr. Davis' health had been greatly impaired and the operation was necessary.

The report published in the last issue of THE CIRCULAR—WEEKLY to the effect that Charles O'Brien would enter the employ of L. W. Vilsack & Co. when that concern opened up at Mr. O'Brien's former location on Woods St. proved to be untrue. L. W. Vilsack & Co. emphatically deny that Mr. O'Brien will be connected with the concern.

The Jewelers' Duck Pin League rolled another match last Thursday night, and

both Roberts teams won from both Wattles teams, while the Reeds defeated the Vilsacks. H. M. Smit, of the J. M. Smit Co., says that the employes of his house would like to roll a game with the league teams, so that there are indications that a challenge will be issued.

Lancaster, Pa.

TRADE CONDITIONS.

The fairly active selling of the new tobacco crop, the staple industry of Lancaster County, which means so much to the business people of this city, has inspired a hope of better things among the local jewelers. Probably a fourth of the crop has been sold, for cash, too, and the jewelers will get their share of what the growers will spend here.

E. H. Keller has just installed in his store a fine, large, new safe.

W. W. Appel had an auction sale for several days last week, and disposed of considerable stock.

Franklin L. Sutter, a Louisville, Ky., jeweler, was married here last Thursday to Miss Anna Farley, formerly of Louisville.

James M. Jenks, formerly a manufacturing jeweler of this city, now of Cleveland, O., spent a few days in Lancaster last week among old friends.

Thirty employes of the Hamilton Watch Co.'s factory one evening last week made a trolley trip to Rohrerstown, where they had a big chicken and waffle supper.

Eugene P. Coho, for the past 11 years with the Hamilton Watch Co., first as secretary and more recently as treasurer, has severed his connection with the company.

Dr. Walter B. Weidler exhibited here at a social entertainment given a few days ago a large eelock of peculiar workmanship taken from the City Hall at San Juan, Porto Rico.

E. P. Zane, Christiana; S. H. Miller, Mt. Joy; J. M. Kreider, Ephrata; J. H. Sensenig and George Townsley, New Holland; Archie May, York, and Peter B. Farley, Pittsburg, were among the visitors to Lancaster last week.

Frank Reaves, superintendent of the watch factory at South Bend, Ind., formerly foreman of the finishing department of the Hamilton factory, spent several days in Lancaster last week, having stopped over on his way to New York.

The Southern Watch Case Co., Nashville, Tenn., has arranged to move to York, the business men of that place having subscribed for \$25,000 of the company's stock. The factory will be the building formerly occupied by the Dentists' Supply Co.

During the late mayoralty campaign very pretty bronze medals in large numbers were struck off for one candidate, Hon. J. P. McCaskey. These have now become a local fad, and have been plated in gold and silver and made in the form of watch fobs, belt buckles and breast pins. Some have been made into very artistic designs.

Messrs. James E. and John F. Ziegler, formerly of Lancaster, who recently went from Tonopah, Nev., to San Francisco, to engage in the jewelry manufacturing business, have written to Lancaster friends that they have located at Stockton, Cal., having been unable to secure a suitable building in San Francisco.

Arthur C. Hart, with Henry Kohn &

Sons, Hartford, Conn., is taking a course in engraving at the Ezra F. Bowman Technical School, Erwin Alderfer, of Norfolk, Va., has entered the school for a course in engraving, and Fred W. Butler, Honesdale, Pa., is taking a course in engraving and watchmaking. Mrs. Harry Knight, Lancaster, is a student in engraving.

Stephen Fletcher, a well-known watch and clock maker, who was employed at the watch factory and among local jewelers many years, was killed last week on the Pennsylvania railroad near Coatesville. It is believed he was hit by a train while walking on the track. He was an Englishman by birth, and was 55 years old. Of recent years he traveled the country, repairing cloeks and watches.

Connecticut.

W. T. Woodruff, Thomaston, has left for an extended tour through the south.

Robert B. Ferguson, with C. H. Leonard, Winsted, will leave March 9 for Owensboro, Ky., where he will reside permanently.

Dave Zoslave, Waterbury, has enlarged his quarters and made extensive improvements to meet the demands of his increasing business.

The movement department of the Seth Thomas Clock Co., Thomaston, has begun to run on a schedule of five days per week, 10 hours per day.

For the second time within a week the store of Louis Faleo, 172 Meadow St., New Haven, was robbed on Monday, of last week. Several fountain pens were stolen.

Joseph Zubkoff, with the Waterbury Clock Co., Waterbury, and who is at present confined in St. Luke's Hospital, New York, has the best wishes of his fellow employes for a speedy recovery.

George W. Eggleston, upon the occasion of his recent resignation from the secretaryship of the Sessions Foundry Co., of Bristol, was presented by the office employes with a beautiful diamond ring.

P. J. Couzens, of the New York office of the Seth Thomas Clock Co., was among the visitors in Thomaston recently, inspecting the record breaking tower clock which has just been completed by the clock company for the Colgate Co., of Jersey City.

Louis C. Hiller, designer for factory "L," International Silver Co., Wallingford, is rapidly recovering from an operation recently performed at the Post-Graduate Hospital in New York. Mr. Hiller will not be able to resume work at the factory for several weeks.

Frank Traceas, who was arrested in Hartford recently, while trying to substitute a bogus diamond for a diamond ring in the store of Wm. T. Stoven, and who is now serving a three months' sentence in jail, is also wanted by the police of Springfield and Lawrence, Mass.

The will of John Insull, father of John C. Insull, of the firm of C. J. Monson, Jr., & Co., New Haven, was admitted to probate, about a week ago. The estate is worth \$10,000. John C. Insull, Mrs. David Ducharme and Mrs. F. B. Buck, all children of the deceased, and A. S. Clark, of Hartford, a stepson, each received one-fifth part of the estate. The remainder is given in trust to Miss Ellen Brown, a granddaughter.

Philadelphia.

Victor Kurtz, 900 Chestnut St., returned last week from an extended trip down east. Joseph K. Davidson, 718 Sansom St., has gone to Florida for a short trip with his mother and sister.

D. V. Brown, manufacturing optician, 740 Sansom St., has gone to Florida with his family for a short pleasure trip.

Dr. George Wardell, formerly a jeweler and optician at Wildwood, N. J., has opened an optical store at Phoenixville, Pa.

T. E. Clayton, Westgrove, N. J., is receiving the congratulations of his friends in the trade on account of his recent marriage.

Philip Cleckley, watchmaker, late with Charles Evans, Reading, Pa., accepted Friday a position with William Davis, 5126 Market St.

H. Samuels, watchmaker, formerly with Lyons & Wilkinson, West Philadelphia, has accepted a position with a jeweler in Co-hoes, N. Y.

A. Gaylord, of H. O. Hurlburt & Sons, is making an extended trip through the State on business, and will visit his old home at Honesdale, Pa.

E. H. Burr, 2452 Frankford Ave., celebrated the 30th anniversary of his marriage, last week, and entertained about 300 guests at the reception.

Edward Harkins, 27th and Diamond Sts., is receiving the congratulations of his friends in the trade upon the birth, last week, of a daughter.

Charles Packard, watchmaker, has resigned his position with R. L. Saunders, 13 S. 8th St., to accept a position with Robert King, Atlantic City, N. J.

Pennington & Hanley, manufacturing jewelers, 27 S. 9th St., Reading, Pa., who have been only recently established, open their place of business formally this week.

Frank Holman, formerly of the jewelry department of Strawbridge & Clothier, has accepted a position as buyer for the silverware and cutlery departments of Gimbel Bros.

A. V. Scott and Mrs. Scott, the former with the R. H. White Co., Boston, who is widely known here, were in this city a few days last week renewing acquaintances with old friends in the trade.

The suit mentioned in a recent issue of THE CIRCULAR—WEEKLY brought by the Superior Comb Co. against I. Press & Son has been settled by the latter out of court and discontinued without costs.

Robert W. King, Atlantic City, stopped off in this city last week on his way south to visit relatives in Baltimore and Washington and to take a rest before the Easter rush starts toward the shore resort.

Henry J. Andrews, manufacturing jeweler, 8th St., near Sansom St., is enjoying a few days this week taking shots at the first flight northward of ducks at his favorite retreat, Beach Haven, N. J.

Thomas Maddock, the veteran traveling man for Simons, Bro. & Co., and reported to be the oldest man on the road in the country, being an octogenarian, departed last week on his usual trip through the south.

William H. Windolph, 56 N. 13th St., has leased the store property at the northeast corner of 12th and Filbert Sts., which is

undergoing extensive alterations. When they are completed Mr. Windolph will move in.

Bellefield Garrison, formerly of the firm of Garrison & Douglass, Camden, N. J., has bought out his brother, Jacob Garrison, Cape May, N. J. The latter is reported to contemplate making his permanent home in the west.

William Huber, Elmer, N. J., is reported to be about to undergo an operation at the Jefferson Hospital, in this city, for stomach trouble, for which he has been under treatment for some time, but the exact nature of which is not yet known.

Col. J. Warner Hutchins, president of the Jewelers' Club, was honored, last week, by being appointed as treasurer of the executive committee, having charge of a complimentary dinner to be given April 1 to State Treasurer John O. Sheatz.

The conclave of the Mystic Shriners at Lu Lu Temple, in this city, last week, attracted here O. O. Stillman, New Brunswick, N. J., and Charles F. Rudolph, Wilmington, Del., both of whom were interested in putting through candidates.

By order of Fred B. Hurlburt, of the firm of H. O. Hurlburt & Sons, the stock of jewelry, diamonds, etc., from the assigned estate of James McCulloch, 33 S. 8th St., were disposed of at public auction to-day. Mr. McCulloch has not yet determined what he shall do.

Harry Oliver, with Tarrant & Gismond, New York, was in this city, last week, renewing old acquaintances and taking good naturedly the scoldings he received because he did not time his trip so as to be here for the annual banquet of the Jewelers' Club, with whose members he is a prime favorite. Mr. Oliver left to go to Chicago and thence to cover the northwest.

M. Sickles & Sons have improved their establishment by adding a new watchmaker's room and a tastefully furnished room for the display of salesmen's samples and for the transaction of such other business as is best done with semi-privacy. Abe and Ed. Sickles returned, Friday, from a fortnight's stay in Bermuda for pleasure. Elmer Horn, of the material department, spent a few days at his parents home in Easton.

Taylor & Co., a new retail firm at 11 S. 9th St., have completed the furnishing of their establishment opposite the Central Post-Office building, and have made it one of the most attractive in that section of the city. Handsome mahogany fixtures have been installed and the place made in every way pleasing to the eye. The formal opening was held Monday, when flowers, cut and potted, contributed to lend color and beauty to the furnishings.

The Bailey, Banks & Biddle Co. placed upon exhibition in their show windows last week the handsome championship cup won by John E. Anderson's *Irene*, of the Corinthian Yacht Club, at the carnival of the Motor Boat Club of America on the Hudson in Autumn of last year. The firm also exhibited the handsomely engraved and framed coat-of-arms of the city of Camden, N. J., which has just been finished by the heraldry department of the company.

Among the visitors from other towns to this city's wholesale trade during the week were the following: Harry S. Yost, Shen-

andoah, Pa.; A. M. Kendall, Millville, N. J.; O. O. Stillman, New Brunswick, N. J.; E. L. Thomas, Phoenixville, Pa.; L. S. Caldwell, Wildwood, N. J.; Jos. H. Shuler, Norristown, Pa.; E. Allez, Millville, N. J.; J. Tausig, of Jacob Tausig's Sons, Harrisburg, Pa.; F. H. Barnett, Birdsboro, Pa., and Charles F. Rudolph, Wilmington, Del.

William Hurlburt, of H. O. Hurlburt & Sons, who has been sojourning at Asheville, N. C., is expected to return this week. Fred Hurlburt proposes soon making a trip to Europe with his family on a sight-seeing and pleasure tour. It is Mr. Hurlburt's annual custom to make a European trip, each year taking in a different country. He has "done" Spain, France, Italy and now will go through England and Scotland. Mr. Leopold, of the traveling staff, has departed for his Spring trip south.

Joseph B. Bechtel & Co., 725 Sansom St., received last week a shipment of boxes containing gross upon gross of jewelers' paper boxes, estimated to have weighed about two tons. The firm proposes hereafter to stamp and print the boxes upon orders received direct from their customers at the printing plant, which is an adjunct to their building. In this way money and time will be saved to the customer. To meet the demands of the trade it was necessary to lay in a large stock of boxes, for which shelving must now be provided. The firm is the first in the east to do its own printing of jewelry boxes, although it is done in some western cities.

Edwin Pomfrey, a watchmaker, employed by C. S. Powell, 8th and Chestnut Sts., and living at 126 W. Gorgas Lane, Germantown, is reported to be one of the heirs of a British estate worth \$17,000,000, for which proceedings are being brought by Joseph W. Pomfrey, Cincinnati. It is claimed that during the Revolutionary War, Pomfrey, of a titled family, deserted the British to join forces with the Americans. After the war the estate reverted to the Crown, but afterward was restored to the family and has been handled by the Chancery Court ever since. Pomfrey, the watchmaker, was amazed to learn that he was to be considered an heir to a big British estate and surprised that the Pomfrey, of Cincinnati, whom he does not know, is related to him.

Trans-Atlantic Voyagers.

TO EUROPE.

Albino Giambetto, Chicago, sails to-morrow for Europe.

A. T. Wall, of A. T. Wall & Co., Providence, R. I., sailed recently.

M. H. Wallenstein, of New York, sailed, March 3, on the *Kaiser Wilhelm II*.

W. M. Birks, of Henry Birks & Sons, Ltd., Montreal, Que., sailed Saturday on the *Maurctania*.

John Wentela, Marquette, Mich., who represents the Singer Sewing Machine Co., has bought out the jewelry store of L. Rinne, in the Caples building on Orange St. Mr. Wentela will move the headquarters of his sewing machine business to the jewelry store. John Niemineman, formerly of Chicago, will have charge of the jewelry department. Mr. and Mrs. Rinne will shortly sail for Finland on a visit of several months.



GNTERPRISING and successful jewelers everywhere are pushing the sale of some individual line of watches which they believe to be superior to all others, and upon which they can also make a satisfactory and justifiable profit.

This explains the growing demand for ILLINOIS WATCHES, in 0, 12, 16 and 18 sizes, by increasing numbers of leading jewelers throughout the United States.

If you are not familiar with the superior quality of—and advantages gained by handling—Illinois Watches, it will mean reputation and dollars for you to investigate.

Every one fully guaranteed.

Price List sent on application.

ILLINOIS WATCH COMPANY

SPRINGFIELD

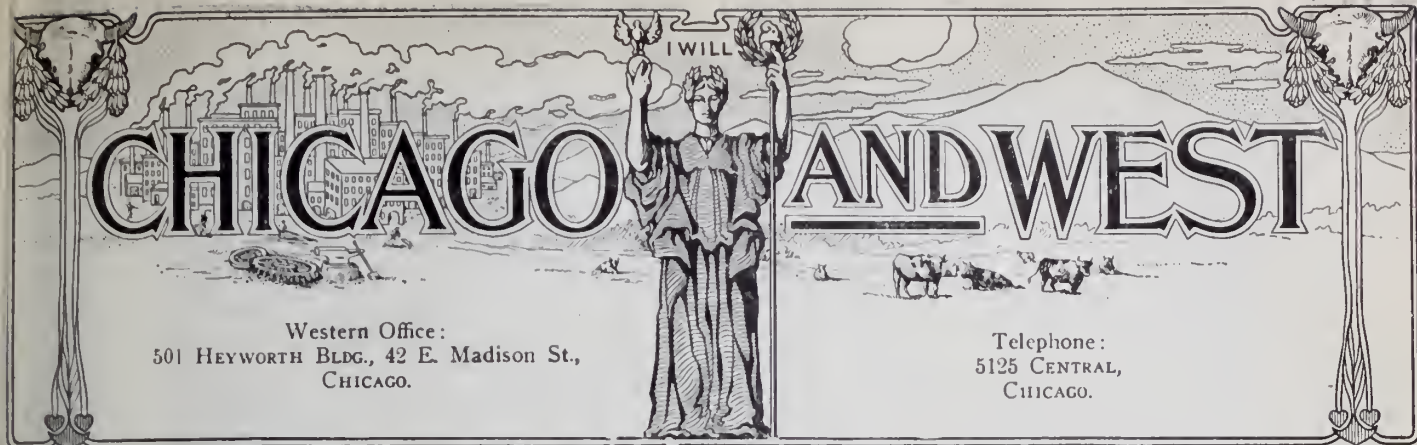

Chicago Notes.

A. C. Becken has returned from an eastern trip.

William H. Carew, Streator, Ill., was recently married.

Geo. Weidig made a flying trip to New York last week.

Jules Franklin, New York, spent a few days here last week.

Mrs. E. Herbst, Sparta, Wis., was among the visitors here last week.

E. V. Wendell and family have returned from a visit to New York.

B. T. Roberts, of Grout's Excelsior Sign Co., is on a trip to New York.

Chas. J. Linden, Kankakee, Ill., was among the buyers here last week.

O. A. Starke, of the Star Watch Case Co., was a visitor to this city last week.

A. L. Williams & Co., manufacturing jewelers in the Powers building, are enlarging their quarters.

Isaac Lazarus, accused by Emil Braude & Bro. of stealing jewelry, is held in \$1,000 bail to the Grand Jury.

Mortimer Collins, with C. D. Gardner, Manistee, Mich., was here last week, accompanied by Mrs. Collins.

Alphonse Judis, accompanied by his wife and son, stopped over in this city last week on his way home to San Francisco.

Messrs. Benedict & Wilkinson were here last week, buying the opening stock for their new store at Sioux Falls, S. Dak.

M. F. Barger & Co. will move, May 1, from the Columbus Memorial building to the ninth floor of the Heyworth building.

News is received here that C. E. Hobson, of the Hobson Jewelry & Music Co., Charleston, Ia., has sold his interest to his partner, Mr. Arnold.

Albert M. Dueber, president and treasurer of the Dueber-Hampden companies, spent 10 days here last week. M. Loeb, with the same companies, was also here.

Albino Giambitto, a retail jeweler at 158 W. Taylor St., will sail for Europe tomorrow, March 12, for a month's visit to Italy. He intends to bring back a consignment of coral.

In a letter to a friend received here last week, Howard Rowbotham, formerly a well-known jewelry salesman here, now in Philadelphia, writes that his mother recently died in Philadelphia.

M. A. Hawber, who formerly kept a retail jewelry store in Monroe, Wis., was in town last week, buying his opening stock

for the new store which he will shortly open in Springfield, Mo.

Jones & Dreyer, installment jewelers, 269 Dearborn St., have secured an extension from their creditors of five months, and will liquidate their liabilities in monthly instalments of 6 1/2 per cent.

Prosper Clust, of Diges & Clust, New York, while here last week was served with papers in a \$10,000 suit for defamation of character brought by Chas. J. Zeller against Mr. Clust's firm. Mr. Zeller was formerly Chicago manager for Diges & Clust.

Among the out-of-town retail jewelers in Chicago last week not previously mentioned were: Robert Koerber, Trenkley & Koerber, Ft. Wayne, Ind.; Mr. Kreig, Kreig & Giles, Kewanee, Ill.; R. L. Jenkins, Amboy, Ill.; F. G. Berta, Coal City, Ill.; C. S. Barrett, Emerick, Barrett & Co., Freeport, Ill., and H. G. Butterfield, Hamburg, Ia.

S. K. Huston is visiting New York and the east this week in the interest of the western creditors of the Madson, Steele Co., bankrupts. Mr. Huston's chief object is to get the creditors to mutually decide on a trustee to take charge of the estate in order to conserve it and save the expensive administration of a receiver. Frank McKee was appointed receiver under a bond of \$20,000. E. D. Buell, O. W. Wallis and H. A. Baby were appointed appraisers of the merchandise last week.

Schedules of the National Jewelry Co., bankrupts, show secured liabilities of \$9,838 and unsecured liabilities of \$13,766. The security given was merchandise to the value of \$12,300. Among the jewelry creditors for less than \$100 each are the Electric Chain Co., E. J. Koch & Co., S. Buchsbaum & Co., F. A. Hardy & Co., A. A. Greene & Co., R. Wallace & Sons Mfg. Co., G. Webster & Co., Wm. L. Gilbert Clock Co. From \$100 to \$200, Attleboro Chain Co. and C. O. Sweet & Son Co.; \$200 to \$300, Leon Hirsch, Plainville Stock Co. and C. F. Monroe Co.; from \$300 to \$400, North American Watch Co. The larger creditors are: L. Fritzsche & Co., \$773; Massover & Pokrass, \$1,362, and S. O. Bigney & Co., \$2,427. The entire estate was sold for \$1,400. The American Trust and Savings Bank has been appointed trustee.

B. Libman, retail jeweler at 473 Ogden Ave., has filed a voluntary petition in bankruptcy, with liabilities of \$475 secured by a chattel mortgage and unsecured liabilities of \$1,986. His assets outside of the goods secured by the chattel mortgage amount to

\$100, on which he claims exemption. Besides money borrowed from various loan concerns he owes the jewelry trade as follows: On claims less than \$50, Wm. L. Gilbert Clock Co., Rockford Watch Co., Silverfield Co., Bartels Optical Co., Seth Thomas Clock Co., Waterbury Clock Co., Omega Watch Co., Moore & Evans, J. D. Bergen Co., C. G. Breitenbach Co., Despres, Bridges & Noel; from \$50 to \$100, Chas. T. Wittstein & Co., John Eulenberg, B. Schuette, Graffe & Stanek, Benj. Allen & Co., Meyer Joseph & Co., A. Hirsch & Co.; from \$100 to \$200, H. Davidson & Co., F. E. Morse Co.

Plan to Wind Up the Shourds-Adcock-Teufel Co.—Involuntary Bankruptcy Petition Filed by Creditors.

CHICAGO, March 7.—The affairs of the Shourds-Adcock-Teufel Co. are expected to be adjusted soon. The corporation wished to discontinue business. Some time ago the concern was granted an extension, and 20 per cent. of the indebtedness was paid. Since then the company owes \$2,000 for additional merchandise bought. The rent is high, amounting to nearly \$20,000 a year. Mr. Adcock is seriously ill, and it is thought best to discontinue the business.

A meeting of creditors was held in New York the latter part of February, and the following plan advised: First, three trustees to be appointed from Chicago—M. A. Mead, of M. A. Mead & Co.; Frank Plon, of the Schrader-Wittstein Co., and Wm. J. Diges, Chicago manager for the Jewelers Board of Trade. These trustees are to dispose of the stock by private sale or auction as they see fit. Twelve thousand dollars due the Hibernia Bank for money loaned the corporation on real estate belonging to Mr. Teufel and \$2,000 due for merchandise bought since the extension to be paid first and in full. The balance of the creditors to receive 50 per cent. of their claims, and the residue, if any, to be turned over to the corporation.

The corporation claims assets of \$107,000, of which \$93,000 is merchandise, and has liabilities of \$51,000, of which \$35,000 is for merchandise.

CHICAGO, March 9.—An involuntary petition in bankruptcy was filed to-day in the United States Court against the Shourds-Adcock-Teufel Co. by Fera & Kadison, W. S. Hedges & Co. and the Whiting Mfg. Co.

TRY IT, OTHERS HAVE

Read
The Letter

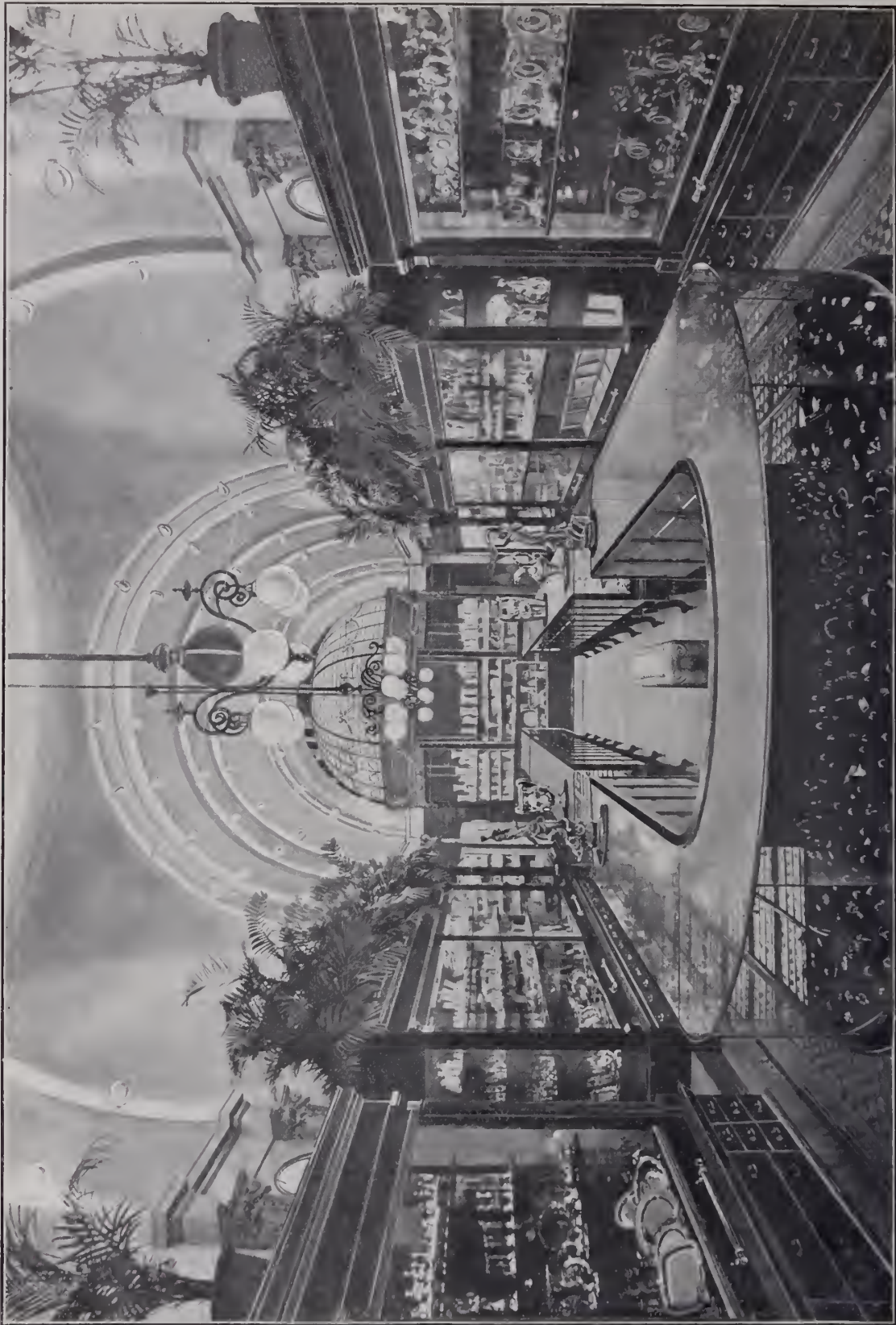

Write us at once for samples and particulars FREE

Our representatives visit nearly every State in the Union. If you are interested, and will notify us, our representative will take pleasure in calling on you and explaining our method.

THE ARNSTINE BROS. COMPANY

Originators of Our Exclusive Catalog Method for the Retail Jeweler
CLEVELAND, OHIO

STORE OF EUGENE V. HAYNES CO., ATLANTA, GA.

(Extracts from Letter)

The Arnstine Bros. Company, Cleveland, Ohio.

Gentlemen:—In reference to yours of recent date inquiring our impression of your Catalogue as an advertising medium, beg to advise that our results therefrom were very gratifying to us. We believe that owing to the financial depression that our sales would have been much smaller than they were had we not used the Catalogue. Yours very truly,
EUGENE V. HAYNES COMPANY.

Atlanta, Ga., Jan. 25, 1908.

Cincinnati.

Jacob Morris, 1227 Vine St., is holding an auction and reports it to be a "closing out" sale.

Nathan Hahn, of Lindenberg, Strauss & Co., has started on his regular western business trip.

Sam J. Loeb, manufacturers' agent, has started on an extended business tour among western cities.

Edward E. Richter, of Richter & Phillips, is home from Chicago, whither he went, last week, on business.

I. D. Waxman, formerly of this city, but now of the R. W. K. Co., Chicago, was here, last week, visiting friends.

The Loring Andrews Co. has just completed an order for diamond earrings worth \$6,000, for Ethel Barrymore.

B. S. Newman and Jonas Wise, of Frohman & Co., are making their respective trips north and through Ohio and Indiana.

Atwood Saunders, with O. V. Neal, Parkerburg, W. Va., stopped over in this city, last week, on his return from his southern trip.

Dan I. Murray, having fully recovered from his illness, with his assistant, James Curran, is conducting the closing out sale of J. H. Baber, Dayton, O.

Charles Hain, a former jeweler at Circleville, O., was here, last week, and stated that he has located in Columbus, O., as an expert and consulting engineer on safe time locks.

Harry Wessel, polisher for Fox Bros. & Co., was run down at 4th and Vine Sts., last week, by an automobile. His condition is not as serious as was first feared, and his speedy recovery is now looked for.

Out-of-town jewelers, who were here during the past week, included: William Shire, Paris, Ky.; J. C. Meyer, Harrison, O.; J. F. Feldman, Chillicothe, O.; Oscar Heidingsfeld, Greenfield, O.; W. L. Lehne and wife, Decatur, Ind.; F. A. Schweetung, Oxford, O.; Frank C. Taylor, Carlisle, Ky.; A. T. Maupin, Athens, W. Va.; J. H. Noyes, Osgood, Ind.; Walter S. Wheaton, Dayton, O.; Mr. Hurwitz, Thurmond, and R. W. Honacker, Hollandsville, W. Va.

On the afternoon of March 3, Henry Michie, of Michie Bros., called at police headquarters and identified a suspect arrested on that morning, saying he was Prentice Tiller, the man who was with Varney at the time Michie Bros.' store was robbed of \$2,500 worth of diamonds 17 years ago. Tiller, the man charged with this robbery, waived examination in police court and was bound over to the Grand Jury. Government officials are also investigating the past few months of Tiller's life. He is suspected of having some knowledge of the recent mail box thefts here, and also throughout Ohio and Indiana. Tiller is also credited with formulating the plans, by which several wholesale jewelry firms have been swindled. For several months past complaints have been made that a band of men have been locating in the small towns as retail jewelers, getting out stationery and then ordering stock. When the goods arrive the "jewelers" disappear. An appeal has been made

by the attorney for Tiller to the prosecuting attorney to release Tiller. The reason given for his release is that the original indictment found against him, Aug. 4, 1891, was nolleed by the late John C. Schwartz, on Dec. 31, 1900. The present prosecuting attorney, however, says the action of his predecessor does not prevent a reconsideration of the case, and he will present the full facts to the Grand Jury, and will prosecute Tiller if a bill is returned.

Indianapolis.

Carl L. Rost was appointed chairman of the Club Property Committee of the Indianapolis Commercial Club, last week.

Asher Gray, of Gray, Gribben & Gray, is spending three weeks in Texas, with a friend who is prospecting. Mr. Gray's trip, however, is merely for pleasure.

J. F. Kiser, Muncie, and John Bauchert, Noblesville, were among Indiana jewelers who visited this city, last week. There were a number of other jewelers in the city, during the week.

After a successful business trip of four weeks, I. Grohs, of the I. Grohs Jewelry Co., returned from St. Louis, Saturday. He met many of his customers from the west and southwest, while in that city.

At the instance of his wife, M. F. Smith, a downtown jeweler of this city, was arrested at Martinsville, one day last week, in the company of a woman. The case against Smith was dismissed in police court here, and friends have arranged for him to stay in a private sanitarium for a short time.

A local newspaper is conducting an advertising plan whereby 11 fortunate young women will be given a free trip to Europe during July and August. Among the young women nominated is Miss Myrtle Hiddinger, a sales woman employed by J. P. Mullally. Local jewelers are taking considerable interest in her campaign.

It has been learned that Ralph W. Worden, arrested here a few days ago and returned to Toledo, O., operated in Chicago, Cleveland, Pittsburg, Columbus, O., St. Paul and Richmond, Ind., besides Toledo and Indianapolis. His scheme was to appoint a resident manager for the "W. A. Rogers' Silver Co.," collect a cash bond and leave the city. He guaranteed the manager a weekly salary of \$10 and commission.

Local police are holding Bert Waterford on charges of grand larceny and burglary. He is suspected of having broken the plate glass window in Carl L. Rost's jewelry store, about three weeks ago, and stealing \$600 worth of diamonds and jewelry. He has been identified as a man who sold a watch and ring, similar to some stolen from Rost's, at Louisville, and it has also been learned that he left a hammer at a pool room shortly after the burglary.

The building formerly occupied by Peter Egloff, Rhinelander, Wis., has been destroyed by fire.

The store of H. F. Beaudry, Union St., Rockland, Mass., was recently entered by burglars, who stole about \$500 worth of stock. There is no clue.

Detroit.

J. G. Bruce, Burnside, purchased stock here, last week.

Frank Preswell, Holly, was a recent visitor in this city.

A. L. Blair, Middleton, was here, recently, visiting the trade.

S. M. Sharer, Dexter, was in Detroit, recently, on a buying trip.

M. D. Walton, Armada, has recently recovered from a severe illness.

Delaney A. Pontius, Algonac, was here to visit the trade, a few days ago.

H. F. Dorweld, of Luths, Dorweld & Haller Co., returned, recently, from a western trip.

L. H. Tyrrell, who started a small store some time ago at 28 Lafayette Boulevard, has discontinued business.

Mr. and Mrs. Adolph Enggass have announced the engagement of their daughter Minna, to Max Philip Heavenrich, Saginaw.

E. C. Avery and E. W. Krainbrink, with the Chas. A. Berkey Co., started out on the road, Monday, after having been in the store a few days, stocking up.

Chas. Miller, a member of the firm of R. J. F. Roehm & Co., and in charge of the manufacturing department, has gone on a trip to Asheville, N. C., with his wife.

J. H. Frease, Napoleon, O., is a motor boat enthusiast, and was here, last week, looking over the speeders on exhibition in the Light Guard Armory. He also called on the wholesale jewelers.

F. Switzer, Mt. Clemens, who came in Friday, had a lively trip as the trolley lines run through a long stretch of territory that is flooded and there was danger that the cars could not get through for a time.

E. S. Barnes, Rochester, was in this city, the earlier part of last week, before the snows melted and told the wholesale merchants that the drifts were 15 feet high in places in the hilly part of Oakland County.

Retail jewelers who visited the wholesale trade, last week, in addition to those mentioned elsewhere, were: J. L. Chapman and L. J. Laurain, Ann Arbor; A. C. Hill, Ypsilanti; Mr. Adams, of Edwards & Adams, Carleton.

Michigan has been singularly free from failures and embarrassments in the jewelry line during the period of financial uncertainty now passing. While many other merchants in various lines have failed, the jewelers have been fortunate. In Detroit the business changes have been practically normal in number, there being only one bankruptcy, a very small one, one trust mortgage and one retirement. No merchant of any standing in the business has felt it necessary to close up. Throughout the State, good crops have saved the situation entirely, except in a few factory towns.

A man giving his name as Robert F. Guilfoyle is said to have passed a number of worthless checks on merchants at Ithaca, N. Y. At the store of C. B. Brown he bought a seal ring for which he gave a check for \$10 and \$1 in change was given him. A number of merchants complained to the police and Guilfoyle was arrested on a train as he was about to leave the city.

New Silk Cord, with Needle, for Stringing Beads

This Silk Cord is Strong and Durable, and made in two sizes, small and medium

No. D7. Small size, per doz. cards, \$0.75
 " D7. Medium size, " " " .75
 " D7. Assorted sizes, " " " .75

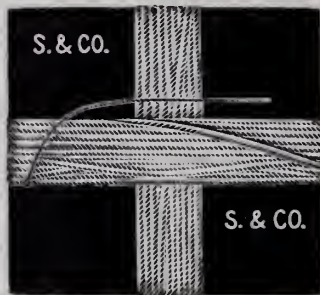

A twisted metal needle, one and a half inches long, is attached to each cord, making it very easy to string beads.

Six Feet of Cord to Each Card.

SWARTCHILD & COMPANY

If you have not a copy of our double-sized 440-page Catalogue, write at once. Sent gratis upon application.

Heyworth Building, Chicago

THE LARGEST EXCLUSIVE JEWELERS' SUPPLY HOUSE IN THE WORLD

ESTABLISHED 1887

DUBOIS WATCH CASE CO.



Manufacturers of

Fine Solid Gold Watch Cases



Specialties in Casing of

CHRONOGRAPHS, REPEATERS AND ALL KINDS OF COMPLICATED WATCHES

NEW YORK OFFICE:
 21-23 Maiden Lane

FACTORY AND MAIN OFFICE:
 316 Herkimer St., Brooklyn, N. Y.

WATCHES OF PRECISION.

Mathey Bros., Mathez & Co.

WATCHES DEMAGNETIZED



Manufacturers and Importers of
Superior, Plain and Complicated Watches.

Sole Agents for

CHAS. H. MEYLAN.

SMALL WATCHES A SPECIALTY.



12 SIZE MOVEMENTS

Brassus, Switzerland

21 MAIDEN LANE, NEW YORK.

12 SIZE SPLITS

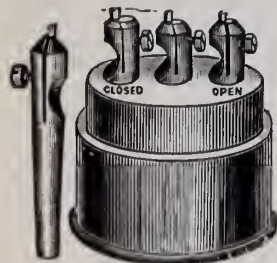

Set of
3 Jewel Setting Cutters
 Price, \$3.00

This set will drill 100 and more sizes of holes.
 Send for Circular

Culman Tools

Are practical—ask the man who owns them if he wants to do without them at any price.

C. CULMAN

Maplewood - - - St. Louis Co., Mo.

Balance Chuck
 Price, \$3.50



Every Chuck or Cutter which becomes worn or broken will be replaced for 25 Cents.

Practical Course in Adjusting

Published Price, \$2.50
 Special Reduced Price, \$1.50, Postpaid

All Jobbers or
 Jewelers' Circular Pub. Co.

Denver.

Sol. Erick, Lafayette, was in this city for a few days last week.

Dan S. Park, of Dan S. Park & Co., ft. last week, for Cheyenne.

J. P. Wilcox, Idaho Springs, Idaho, was one of the buyers in this city last week.

Mr. Park, with E. L. Hunhan, Greeley, was in the city for a few days, last week, on business.

Mr. Burns, of Juergens & Andersen Co., Chicago, was in this city for a few days, visiting the trade, last week.

Roy S. Smith, formerly of Longmont, Colo., has sold his business there. He intends to start a new store at Lincoln, Nebr.

Daniel G. Weil, of the I. C. Weil Curio Co., left, last week, on his vacation. He intends going into the mountains and will be gone a couple of weeks.

Mr. Howells, Florence, was in the city last week, and made several large purchases from the jobbers to replenish his stock, which has been depleted considerably.

Mr. Bohm, of the Bohm-Allen Jewelry Co., left, last week, on a trip to New York. He is purchasing goods for his firm here, and is also taking the trip for pleasure.

Mr. Johnson, representing the Board of Trade of New York, has been in this city for a few days. He has been getting reports on the standing and credit of the local jewelers.

Mr. Ashby, of the Ashby Jewelry Co., Colorado Springs, had his store damaged to the extent of \$3,000 by fire recently. It is said that defective wiring was the cause of the fire.

Mr. Fulton, of the Lewis Jewelers' Supply Co., returned last week from his trip to the northwest. He reports a very successful business and a good outlook for the coming Summer.

W. W. Hamilton, of the W. W. Hamilton Jewelry Co., has left for an extended trip abroad. He will visit Palestine and the Holy Land. He sailed from New York on the steamship *Arabic*.

Mrs. Ada Smith is on trial before Justice Carlon on a charge of stealing an \$8 garnet ring from George Reinhardt, 2052 Larimer St. Mr. Reinhardt alleges that he showed some rings with garnet settings to Mrs. Smith; that she asked to look at diamond rings, and then failed to return a garnet ring. Mr. Reinhardt testified that when he asked for its return Mrs. Smith went dashing down the street, with the ring. He says he attempted to see her at her home, 2512 Lawrence St., several times, but unsuccessfully.

Minneapolis and St. Paul.

C. A. Hoffman, Minneapolis, is at present in Honolulu in the interests of his firm.

Axel Madsen, of Rettig, Hess & Madsen, Chicago, has gone to Dakota, on a regular trip. Mr. Madsen resides in Minneapolis.

R. G. Winter, of the R. G. Winter Jewelry Co., Minneapolis, has gone east on a business trip.

Several storekeepers of Minneapolis have agreed to remove advertising signs, which are supposed to obstruct one's view and appear unsightly. Among those who have decided to remove signs are; White

& MacNaught, E. D. Best Co., and several others.

Frank A. Upham, a jeweler of 111 E. 7th St., St. Paul, fell unconscious in his store while engaged in conversation with his son, last week. He was removed to a hospital at once, and made good progress toward recovery, his condition not being regarded as serious.

E. A. Kirchner, of Kirchner & Renich, Minneapolis, has been granted a patent on a self-righting dating stamp. It consists of a weighted handle, so arranged that pressure in the act of picking up the stamp will turn it to the proper position for stamping the date right side up. The same appliance can be used upon receipting stamps, or, in fact, upon any kind of a rubber stamp.

Los Angeles.

Edward Gerson is now settled in a new and handsome store at 545 S. Broadway.

J. P. Jaeger, of Jaeger Bros., Portland, Ore., has been spending a few weeks here.

The J. P. Trafton Co. moved, a few days ago, to its new location on Broadway.

A recent message from H. J. Whitley, now abroad, indicates that he will arrive home about March 22.

J. H. Birnbaum, of Birnbaum Bros., has been suffering from an attack of grippe, which confined him to his home for several days.

J. H. Padgham, Santa Ana, and A. W. Elliott, Santa Paula, were in Los Angeles, a few days ago. Both came to do business with the wholesalers here.

William Petry, gem cutter, at 114 S. Spring St., is now engaged in cutting a quantity of very fine green and blue gold quartz, brought from Nevada. It is made mostly in designs for pendants.

J. Belgard has bought out the interest of J. Posner in the Crown Jewelry Co., 415 S. Spring St., and also the stock and fixtures of the Peerless Store, 433 S. Broadway. He assumes all liabilities and will continue the business at the present location of the Crown Jewelry Co.

Fire, which started from an electric light wire in the window of the Geneva Watch & Optical Co., on Broadway, near 3d St., recently, threatened to do serious damage. Fortunately it was discovered promptly. The fire department was called and soon extinguished the blaze.

Energetic operations are in progress at the northwest corner of Broadway and 4th St., where the ground floor of what constituted three stores, occupied by the Cummings Shoe Co., Edward Gerson, jeweler, and Sanborn Vail & Co., stationers, is being prepared for the occupancy of Montgomery Bros., as a jewelry store. Before night on the first day the partitions and practically the entire interior of the three rooms had been removed. The store will be, with possibly one or two exceptions, the largest and finest retail jewelry store in the United States.

E. W. Dick, an employe in the jewelry store of Moses D. Brandes, Birmingham, Ala., was recently brought to court on the charge of taking several pieces of jewelry, the property of his employer. When a bond was required his employer signed it.

San Francisco.

Mr. Delovage, Portland, Ore., was in this city a few days ago.

W. T. Harris, Los Angeles, has been in San Francisco for the past week.

Walter P. Marble and Mr. Metcalf have just returned from a trip to Samoa.

The local office of the Martin-Copland Co. is installing a burglar alarm system.

Geo. H. Doerr, Spokane, Wash., spent several days, last week, in San Francisco.

George Smith, of the Keystone Watch Case Co., has just returned from his visit to the east.

McGraw & Lazarus have finished fitting up their new store at 245 Montgomery St., and are now open for business.

Felix Friedlander, Portland, Ore., is here, in company with his wife. They have just returned from southern California.

Mr. Turtleotte, of the Waite-Thresher Co., stopped in this city, last week, on his way east, after a vacation in Los Angeles and Santa Catalina Island.

Mr. Mason, of the Potter & Buffinton Co., is stopping in San Francisco on a pleasure trip, in company with his wife. He is also transacting business for his firm with local houses.

L. O. Levison, of the California Jewelry Co., who has been in Europe for some time past, is expected here about March 15. He will spend a few days in some of the eastern cities on his way.

The large stock of jewelry which was carried by the bankrupt general store of Kragens will soon be sold for the benefit of creditors. The creditors' committee has advertised for sealed bids on the stock.

Among the recent out-of-town jewelers in this city not elsewhere mentioned, were: Mr. Cochran, Lord, Cochran Jewelry Co., Goldfield, Nev.; E. R. Hubbard, Lompoc, Cal.; Walter King, Stockton, Cal.; Mr. Powell, Powell-McKee & Co., Sacramento, Cal.; Geo. Penniman and Mr. Schwartzkopf, Los Angeles.

Omaha.

L. E. Griffith is making a business trip through the State.

Geo. W. Ryan was in Grand Island, Nebr., on business, last week.

Mr. Sarter, of the Sarter Jewelry Co., Lincoln, Nebr., was a visitor in this city, last week.

Chas. Krause, Randolph, Nebr., and M. L. Kile, Creighton, Nebr., have recently equipped their dark rooms with new optical instruments of the latest design.

Ed. Keating, formerly with H. Copley, but now with Swartzchild & Co., Chicago, Ill., spent a few days in the city calling on the trade and visiting old friends.

The Omaha Silver Co., of this city, was recently purchased by B. L. Kemper, W. G. Hemphill and J. H. Buckinham. The plant will be managed by W. G. Hamphill.

S. W. Lindsay fell down the stairs at his home, last week, and received injuries which, while not serious, will compel him to remain at home during the entire week.

W. B. Graves, Elkhorn, Nebr.; Mr. Muddra, Stanton, Nebr.; F. T. Johnson, Genoa, Nebr.; E. J. Niewohner, Columbus, Nebr., and John Albright, David City, Nebr., were in the city, last week, replenishing stocks.

Pacific Coast Notes.

Eugene Hess, Frankfort, Germany, is visiting in Oakland, Cal.

Arthur G. Perham, Ontario, Cal., is closing out his stock at auction.

B. Jackson, Gridley, Cal., has opened a branch store in Biggs, Cal.

Ira Smith has sold his business on W. 2d St., Pomona, Cal., preparatory to removing to Pasadena.

I. H. Herold, Oakland, Cal., was robbed last week of stock worth \$125. A billiard parlor owned by Mr. Herold was robbed about the same time.

Chas. E. Perham has added a watch repairing department to his business at 603 Beacon St., San Pedro, Cal., and James S. Baker, of Los Angeles, has been placed in charge.

David Davis, formerly of Bakersfield, Cal., who was recently acquitted on a charge of stealing a large amount of diamonds from Solomon & Law, of that town, has become insane.

Arthur Everitt, Albuquerque, N. Mex., has donated to the board of control of the National Irrigation Congress two silver trophy cups, each 14 inches high and eight inches wide, to be awarded for the best exhibits of fruits and cereals.

Frank H. Guernsey, Tropic, Cal., has purchased the stock and business of P. W. Andrews, on 4th St., just west of Glendale Ave. Mr. Guernsey was formerly employed with the Fleming Optical Co., in Los Angeles, for several years and later conducted a watch department of his own in connection with the Chas. F. Nieman Co., in Los Angeles.

An auction sale is being carried on to dispose of the stock of Manson & Bay, Redlands, Cal. The sale will last until the entire stock is sold. Reasons given by Mr. Bay for closing out his business are that he intends to go east and take a course in an optical college, and after completing the course, will return to Redlands and open a general optical business.

J. R. Williams, Needles, Cal., who has been official watch and clock inspector for the A. T. & S. F. Railway Co., for the past six years, has just accepted an appointment as official watch and clock inspector for the Southern Pacific Railroad Co. This will in no way interfere with his present business in Needles. Mr. Williams has just installed a \$200 Eaton & Glover Co.'s New Century engraving machine in his establishment.

Pacific Northwest.

Emil Pfund, Aberdeen, Wash., has asked for an extension.

Grover Bros., Snohomish, Wash., have filed a petition in bankruptcy.

Wm. E. Loomis, Ontario, Ore., recently filed a petition in bankruptcy.

The Crown Jewelry Co., Seattle, Wash., is now in the hands of a trustee.

K. Ackert, Centralia, Wash., is looking for a location to open a store at Elma, Wash.

J. A. Hyde is erecting a new building on 1st St., Kalama, Wash., which is to be occupied by C. M. Salisbury.

Dr. W. A. Ingalls, Prosser, Wash., has purchased the interest of his partner, A. R. McLane, in the firm of McLane & Ingalls.

Mr. McLane leaves the business on account of ill health.

Robert Henry Robinson, Condon, Ore., died suddenly a few days ago of pneumonia. He was formerly in business in Arlington, Ore. He was prominent in civic and Masonic circles, and is mourned by many friends.

Six claims have been filed by various wholesale firms in the United States against Herman I. Segerstrom, a dealer at Wallace, Idaho. The claims aggregate the sum of \$5,841.71, and have been allowed by the referee in bankruptcy for the county.

St. Louis.

J. J. Gaffner, St. Jacob, Ill., was visited last week by the stork, which brought an infant son to his house.

Charles Hellwig has opened a store in the Star building, 12th and Olive Sts., in the quarters occupied formerly by Edward Barfield.

The annual meeting and election of officers of the Retail Jewelers' Association of St. Louis will be held this month at the Jefferson Hotel.

Many of the jobbers and manufacturers have announced that they will close at noon on Saturdays during the Spring and Summer months. Several of them inaugurated the half holiday, last Saturday.

Among the out-of-town jewelers who called on the local trade, last week, were: A. H. Krause, Greenville, Ill.; L. J. Wick, Highland, Ill.; John Roark, Winchester, Ill.; Harry J. White, of the Krug-White Jewelry Co., Staunton, Ill.

A burglar recently broke into the pawn shop of J. Wittels, 1529 Market St., this city, and escaped with \$300 worth of jewels. The rear door showed that the thief used an auger with which he bored holes in the panels and then inserting his hand pulled the iron bar that kept the door locked.

Max M. Freund, Brooklyn, N. Y., accompanied by his wife, is spending two weeks with his sister and brother, J. L. Freund, of this city. The visitors are on their return from an extended honeymoon trip to Washington and other points, extending as far south as Havana, Cuba. The groom is a jeweler of Brooklyn, and the bride was formerly Miss Sadie Cohen, of Buffalo, N. Y.

The East St. Louis Jewelers' Association, which was projected two weeks ago at a preliminary meeting of several of the largest jewelers in that city, has perfected its organization and elected the following officers: Charles G. Derleth, president; Edw. S. Jacobs, of Vahlman & Jacobs Jewelry Co., secretary; Bernhard M. Fink, vice-president, and A. M. Zerweck, of the Zerweck Jewelry Co., treasurer.

At a recent meeting of creditors of the Canadian Jewelry & Importing Co., Montreal, Que., held at the Manufacturing Jewelers' Board of Trade in Providence, R. I., a composition settlement of 50 per cent. was submitted, payable in six equal instalments in three, six, nine, 12, 15 and 18 months from March 1, 1908. The assets are placed at \$127,673, with liabilities of \$149,578, of which there are preferential and secured creditors, whose claims aggregate \$32,723. A committee was appointed from the Manufacturing Jewelers' Board of Trade.

Kansas City.

TRADE CONDITIONS.

The consensus of opinion among dealers here is that trade is holding up well, taking into consideration the time of year and prevailing business conditions. Business cannot be classed as brisk, neither can it be classed as dull. Some find it a little slow, while others say it is up to the average and few claim it is improving. On the whole the outlook may be classed as hopeful. This is due not so much to conditions right here in the city as to the reports that are coming in from the smaller cities and towns in Kansas City territory. Nearly all of them are reporting a better trade than was looked for, which means a reduction of stocks that will call for early buying, and a corresponding improvement in the trade of the manufacturer and jobber. Collections have been fairly satisfactory and there are but few complaints of slow payments.

S. J. Huey, Excelsior Springs, Mo., has gone to California for a sojourn of several weeks.

J. F. Holbrook, Mound City, Kans., was in this city early in the week, attending the funeral of his sister.

G. V. Dickinson, general sales agent of the Elgin National Watch Co., was a visitor in this city early in the week.

Mr. Fernald and wife, Carroll, Ia., stopped off here for a couple of days on their return trip from San Francisco, Cal.

J. H. Whitney, traveling representative in Kansas for the Edwards & Sloane Jewelry Co., is in this city refilling his trunks for another trip.

C. B. Norton, of the C. B. Norton Jewelry Co., attended the session of the Nebraska State Jewelers' Association, at Lincoln, Nebr., last week.

H. E. Rakeman, Sapulpa, Okla., passed through this city, Thursday, on his return from Clifton, Kans., where he went to attend the funeral of his grandmother.

J. F. Mulhaupt, a clerk in the employ of the Woodstock-Hocfer Watch & Jewelry Co., who has been on the sick list for a couple of weeks with the grippe, is again able to give attention to his duties.

M. S. Murray, traveling representative for the C. B. Norton Jewelry Co., who has just returned from a trip through Texas, says he found business fairly good. As soon as he can replenish his trunks he will take to the road again.

W. S. Schumann, Oklahoma salesman for the C. B. Norton Jewelry Co., who has just returned from his territory, reports business very fair. In the western part of the State dealers say business is good. Crops are in fine condition and the outlook is very promising for an exceedingly good business next Fall.

Among the out-of-town jewelers here during the past week were: R. H. Morehouse, Topeka, Kans.; C. B. Libbey, Weir, Kans.; C. A. Clement, Springfield, Mo.; F. R. Cullumber, Eldon, Mo.; Mr. Armstrong, of the Armstrong Jewelry Co., Brownwood, Tex.; George A. Young, Moberly, Mo.; F. M. Goodnight, Crescent, Okla.; H. L. Morrison, Pittsburg, Kans.; J. H. Reynolds, Marshall, Okla.; T. S. Mendenhall, Burr Oak, Kans.; Carl Ricker, Emporia, Kans.; R. A. Helmar, South Auburn, Nebr.; L. Megede, Richmond, Mo.

B. H. Stephenson has purchased the department store stock of Anthes & Smith, in Norfolk, Nebr.

INDEX TO ADVERTISEMENTS.

Aln Mfg. Co.	Inside front cover	Heller, L. & Son.....	42	Potter & Bullinton Co.	27
American Gem & Pearl Co.....	52	Herpers Bros.	94	Prior, Charles M.	76
American Platinum Works.....	94	Himalaya Mining Co.	66	Prybil, P.	94
American Watch Case Co.....	90	Hodenspyl & Walker.....	44	Racine, Jules, & Co.....	88
Arch Crown Mfg. Co.....	27	Hoffman Novelty Co.....	100	Randall, C. Ray.....	13
Arizona Turquoise Mines Co.....	46	Hold On Clutch Co.	28	Ranlett & Lowell Co.....	98
Austein Bros. & Co.....	38	Hotel St. James.....	96	Reichhelm, E. P., & Co.....	94
Auristine Bros. Co.....	68	Howard, E. Clock Co.....	90	Reichman, A.	48
Austlu, John, & Son.....	103	Iraba, Louis W.	96	Renziehausen, W. F., & Co.....	102
Bagg & Co.	16	Hyde & Co.	22	Revell, A. H., & Co.....	101
Baker, Geo. M.	102	Illinois Watch Co.	66	Rice's, Bernard, Sons.....	101
Bain, Webb C., Watch Co.....	90	Irons, Joseph.....	96	Richards, J. M.	42
Baschkopf, Henry.....	24	Irving Cut Glass Co.....	96	Richardson, Enos, & Co.....	18
Bassett Jewelry Co.	30	Jacot Music Box Co.....	96	Robbins, Chas. M., Co.....	32
Bates & Bacon.....	12	Janitschek Co.	100	Robert, E. E.	89
Berge, J. & H.	103	Jeanne, F. A.	48	Rockford Watch Co.	77
Billings, Chester, & Son.....	14	Jergensen, Jules.....	91	Roger Williams Silver Co.....	30
Bippart, Griscom & Osborn.....	23	Juzek, T. J., & Co.....	100	Rohrbeck, John E.....	64
Black, R. W.	103	Kahn, L. & M., & Co.....	38	Roseman, A.	54
Blackinton, R., & Co.....	8	Keller Jewelry Mfg. Co.....	22	Roy Watch Case Co.....	80
Borrelli & Vitelli.....	50	Kelly & Stehman.....	96	Rudolph & Snedeker.....	91
Bowden, J. B., & Co.....	25	Kent & Woodland.....	24	Rumpp, C. F., & Sons.....	98
Bradley Polytechnic Institute.....	91	Ketcham & McDougall.....	31	Saart, W. H., Co.....	57
Briggs, D. F., Co.....	14	Keystone Watch Case Co.....	86	Saunders, Menrer & Co.....	48
Bryant, M. B., & Co.....	25	Kirby, H. A.	60	Schultz & Co., Inc.....	24
Burter, Howe & Co.....	21	Kohlbusch, Herman, Sr.....	94	Sessions Clock Co.	76
Chatham National Bank.....	64	Kohn, Alois, & Co.....	25	Shepard Mfg. Co.	32
Chicago Art Metal Works.....	22	Kollmar-Rauch & Co.....	21	Smith, Alfred H., & Co.....	42
Chopard Frères.....	26	Kremenz & Co.	17	Smith, Frank W., Co.....	16
Chottle, S., Co.....	22	Kuehl, Geo., & Co.....	77	Snow & Westcott.....	22
Chrees & Court.....	31	Langendorf Watch Co.....	76	Sohn & Hyman.....	54
Chrohn, M.	29	Larter & Sons.....	36	Solidarity Watch Case Co.....	16
Chross & Beguelin.....	44, 60	Lederer, S. & B. Co.....	30	Spencer, E. L., Co.....	27
Chrossman Co.	52	Lees & Sanders.....	102	Star Watch Case Co.....	6
Crouch & Fitzgerald.....	100	Lelong, L., & Bro.....	103	State Bank.....	62
Culman, C.	70	Lewy & Cohen.....	100	Steiner, Louis.....	101
Day, Clark & Co.....	23	Lisner, D., & Co.....	14	Stern Bros. & Co.....48, inside back cover	
Deacon, Louis J.	24	Lissauer & Co.....	52	Stern, S., & Co.....	12
Dixon, Wm., Inc.....	102	Lorsch, Albert, & Co.....	38	St. Louis Watchmaking School.....	30
Doran, Bagnall & Co.....	26	Loth, Joseph, & Co.....	100	Street, Geo. O., & Sons.....	64
Dorfinger, C., & Sons.....	96	Lowe, Edwin, & Co., Inc.....	30	Sussfeld, Lorsch & Co.....	101
Draper, O. M., Estate.....	29	Maintien Bros. & Elliot.....	25	Swartchild & Co.	70
Dubois Watch Case Co.....	70	Market & Fulton National Bank.....	62	Theberath & Co.	21
Dueber-Hampden Watch Mfg. Co.....	10	Mathey Bros., Mathez Co.....	70	Title Guarantee & Trust Co.....	62
Dunn, T. J., Co.....	26	Mercantile National Bank.....	63	Trout, Charles L., & Co.....	22
Durand & Co.	18	Meyerowitz Bros.....	42	Turner, John F.	66
Eichberg & Co.	66	Miller, Fuller & Whiting Co.....	57	Unique Art Glass & Metal Co.....	98
Eisenmann Bros.....	44	Miller, L. A. (Insurance).....	66	Untermeyer-Robbins Co.....	54
Elgin National Watch Co.....	84	Morstrom, W. G.	52	Urich, S.	100
E. P. H. Chain Catch.....	24	Mount & Woodhull.....	46	U. S. Smelting & Refining Works.....	103
Eveson Co.	76	Myers, J. A.	76	Vacheron & Constantin.....	89
Fahys, Joseph, & Co.....	3	Myers, S. F., Co.....	26	Van Dam, Eduard.....	40
Feldenheimer, Louis.....	50	Nassau Bank.....	62	Van Dusen & Stokes Co.....	29
Foster, Theodore W., & Bro. Co.....	34	New England Watch Co.....	91	Vacher Mfg. Co.	91
Freeman, B. S., Co.....	29	New York Jewelry Purchasing Co.....	28	Waite-Thresher Co.	31
Freund, Henry, & Bro.....	15	Nissen, Ludwig, & Co.....	46	Waltham Watch Co.	82
Galaway, J. H. & F. H.....	103	Noel, Rudolph, & Co.....	40	Washburn, C. Irving.....	98
Garreaud & Griser.....	26	Omega Watches.....	89	Wells, Chester H.....	29
Gillette Sales Co.....	33	Oneida Community, Ltd.....Outside back cover		Wendell & Co.	7
Glendore, H. E., & Co.....	78	Oppenheimer Bros. & Veith.....	40	Wheeler, Hayden W., & Co.....	40
Goodfriend Bros.....	50	Oskamp-Nolting & Co.....	24	Whiting & Davis.....	13
Gorham Co.	58	Osmers-Dougherty Co.....	24	Whiting Mfg. Co.	9
Greene, Wm. C., Co.....	28	Osmun-Parker Mfg. Co.....	18	Wightman & Hough Co.....	28
Griffoul, August.....	102	Ostby & Barton Co.....	15	Wittstein, Chas. T.....	27
Groen, H. A., & Bro.....	64	Pairpoint Corporation.....	96	Wolcott Mfg. Co.	11
Gugenheim, M.	57	Papazien, A. D.	88	Wolfsbeim & Sachs.....	30
Hagstoz, T. B., Ltd.....	102	Patek, Philippe & Co.....	58	Wollstein, L. & M.....	103
Hammel, Riglander & Co.....	104	Peufold, Wm. C., Co.....	90	Wood, Chas. F., & Co.....	44
Harris & Harrington.....	88	Peninsular Engraving Co.....19, 20		Wood, J. R., & Sons.....4, 5	
Hedges, A. J., & Co.....	23	Pitcairn, W. S.	98	Zarembowitz, A.	94
Hedges, Wm. S., & Co.....	48	Pitzele, S.	26	Zimmern, Henry, & Co.....	103

Special Notices.

Payable invariably in advance.

Rates 75c. per insertion for notices not exceeding 25 words; additional words, 2c. each.

SITUATIONS WANTED, 1c. a word each insertion; minimum charge, 25c.

Heavy type, 5c. a word; minimum charge, \$1.25. Display cards, \$2.00 per inch.

In all cases, if answers are to be forwarded, 10c. extra to cover postage must be enclosed.

All answers to advertisements addressed care *The Jewelers' Circular-Weekly*, should be sent to the New York Office, unless the Chicago Office is specifically mentioned.

Situations Wanted.

ENGRAVER and saleslady, experienced; best of references. Address "P. C. L., 3514," care Jewelers' Circular-Weekly.

YOUNG MAN, watchmaker and engraver, desires steady position; has tools. Address "H., 3607," care Jewelers' Circular-Weekly.

THOROUGH, practical, rapid and experienced watch repairer, disengaged April 1. J. A. Coon, 548 Warren St., Hudson, N. Y.

POSITION WANTED by engraver; all kinds of lettering and monograms; references given. Urban Dean, Cameron Mills, N. Y.

EXPERIENCED silverware and jewelry salesman, road or retail, retail preferred. Address "R., 3594," care Jewelers' Circular-Weekly.

FIRST CLASS Parisian jeweler, 28, wishes position; can furnish best reference. Address "J., 3599," care Jewelers' Circular-Weekly.

CHASER, on silver hollow ware, who understands modeling, desires position; seven years' experience. "Bokor," 524 E. 85th St., New York.

WATCHMAKER-wants position; experienced on Swiss and American watches, with complete set of tools. Ed. Herzberg, 402 E. 79th St., New York.

FIRST CLASS watchmaker desires to make a change; young man, good habits; A1 references. "Watchmaker, 3530," care Jewelers' Circular-Weekly.

ENGRAVER, three years' experience on ornamental engraving, desires position; A1 reference. Address "W., 3597," care Jewelers' Circular-Weekly.

WATCHMAKER and salesman, first class, young man, desires permanent position; best reference. Address "S., 3636," care Jewelers' Circular-Weekly.

WATCHMAKER, who is 24 years old, wishes a good, steady position with a reliable firm. Address "H. V., 3644," care Jewelers' Circular-Weekly.

SILVERSMITH, 25, German, on silver hollow ware, desires position; first class references. "Goldberger," care Wimmer, 548 E. 82d St., New York.

YOUNG MAN, experienced engraver, wants immediate and permanent position; can do some clock and die work. Ross Starkweather, Johnstown, N. Y.

FIRST CLASS diamond setter on fine jewelry desires position at once; no objection to going out of town. Address "E., 3523," care Jewelers' Circular-Weekly.

POSITION WANTED as watchmaker; own tools; three years' experience; near Toledo, O., preferred. Address "G., 3591," care Jewelers' Circular-Weekly.

PRACTICAL WATCHMAKER desires position with first class house, to repair watches by piece work. "Watchmaker, 3625," care Jewelers' Circular-Weekly.

WANTED, good, steady position as watchmaker and engraver, or watchmaker and optician, at good wages. H. W. Putney, 126 N. 8th St., Allentown, Pa.

FIRST CLASS jeweler on new and repair work, 18 years' experience, wants position; best references; good habits. Wm. Vehs, 778 Hunterdon St., Newark, N. J.

WANTED, by an experienced young lady, a position as engraver, willing to act as saleslady; best of reference. Address "Redman," 11 Smith Block, Auburn, N. Y.

WANTED, by strictly first class watchmaker, position in west or middle west; best of references; 11 years at bench. Address "X.," P. O. Box 524, Sacramento, Cal.

POSITION WANTED by first class jobbing jeweler, special order work, stone setter and colorer; 20 years' experience. Address M. J. Nolan, 337 E. 134th St., New York.

YOUNG MAN, 9 years' experience in retail jewelry business, desires position in retail or wholesale house; willing to travel. "K., 3510," care Jewelers' Circular-Weekly.

YOUNG MAN, 21, having six years' experience in the wholesale jewelry business, desires a position; A1 reference. Address "N., 3651," care Jewelers' Circular-Weekly.

FIRST CLASS watchmaker, with tools, desires position at once; middle age man; competent to handle railroad work. Address "E. H. B.," 45 Charles St., Springfield, Mass.

WATCHMAKER desires to make a change; experienced on railroad work, at present head watchmaker for railroad inspector. Address "A., 3614," care Jewelers' Circular-Weekly.

FIRST CLASS watchmaker, jeweler and good engraver; all tools; no bad habits, steady; long experience. Conrad Kohler, care Ruff, jeweler, 146 Clinton St., Johnstown, Pa.

JEWELER, 28 years, six years with first class Parisian firm, speaks French, German and English, desires position; best reference. "J. H.," 317 Spruce St., Philadelphia, Pa.

FIRST CLASS watchmaker, good engraver, understands railroad watch work and inspection; age 35, married; best of references; wages, \$25 per week. 816 State St., Alton, Ill.

PERMANENT POSITION by young man, first class watchmaker, jeweler and monogram engraver; married. Address W. L. Primrose, 125 S. 7th St., Grand Junction, Colo.

EXPERIENCED watchmaker and engraver would like permanent position in first class store, desires a change; east preferred. Address "A. R., 3645," care Jewelers' Circular-Weekly.

WATCHMAKER, engraver and optician wants permanent position; have had first position for past year; can give reference. Address "M., 3528," care Jewelers' Circular-Weekly.

YOUNG MAN, 21, having almost five years' experience with diamond importing house, desires to make a change; can furnish best of references. "M., 3639," care Jewelers' Circular-Weekly.

POSITION WANTED by first class watchmaker, expert clock and difficult jewelry repairer and stone setter; 42 years of age. Address W. Bird, watchmaker, General Delivery, New York.

JEWELER, experienced on fine diamond platinum mountings and gold work, with some knowledge of designing, desires steady position. Address "C., 3582," care Jewelers' Circular-Weekly.

WANTED, a permanent position by first class watchmaker and good engraver, with fine reference from last place. Address "Watchmaker and Engraver," 336 W. North St., York, Pa.

ENGRAVER; experienced letter and monogram engraver, could assist on clocks, open for position April 1; young man, very best reference. Address Box 3587, care Jewelers' Circular-Weekly.

WANTED, position, somewhere in south, by first class jobbing jeweler, who can also do new work and stone setting; can furnish A1 reference. Address "T. S., 3655," care Jewelers' Circular-Weekly.

YOUNG MAN, 24, thoroughly experienced in the jewelry business, desires position in same line, where advancement keeps pace with ability; A1 references. F. Winter, 312 Stockton St., Brooklyn, N. Y.

WANTED, position as salesman or manager with retail jeweler; 15 years' experience, good references; married, 28, good address; I can fill the bill. J. P. Turner, 1729 Edmondson Ave., Baltimore, Md.

YOUNG MAN, 19, desires office position with diamond or jewelry house; three years' experience; highest references; willing and accurate; moderate salary. "W. W., 3634," care Jewelers' Circular-Weekly.

A YOUNG LADY, experienced as buyer for the jewelry trade in any branch, would like position as such; excellent reference in regard to taste and capability. "X., 3609," care Jewelers' Circular-Weekly.

ENGRAVER, young man, desires position with first class engraver, or an opportunity to learn watch work; good script letterer; samples on request; A1 reference. "D., 3602," care Jewelers' Circular-Weekly.

TRAVELING SALESMAN desires change; highest reference, with good trade in Pennsylvania, New York, Ohio, Illinois and Missouri; general jewelry line preferred. "V., 3596," care Jewelers' Circular-Weekly.

A1 WATCHMAKER, jeweler and engraver desires a change; Indiana or Illinois preferred; can furnish any reference; positively no bad habits; \$21 per week to start. "C., 3546," care Jewelers' Circular-Weekly.

BOOKKEEPER, double entry, 20 years with present employer, owing to firm retiring from business May 1, am open for engagement; best reference. Address "G. T. L., 3650," care Jewelers' Circular-Weekly.

WANTED, position as traveling salesman for manufacturer or jobber by young man; prefer western territory; 12 years' experience in jewelry business. Address "G., 3615," care Jewelers' Circular-Weekly.

MANUFACTURER'S LINE wanted on commission for jobbers or department store trade for New York City; established trade, can show good improvements. Address Eric R. Sheppard, 58 Maiden Lane, New York.

A FIRST CLASS WATCHMAKER, with many years' experience in high grade adjusting and complicated watch work, wishes to make a change in his position. Reply to Nils Zetterquist, 70 Columbus Ave., Waltham, Mass.

GOOD ENGRAVER and clockmaker, young man of experience, wishes a position with reliable store; west preferred; references and samples cheerfully submitted. E. W. King, care General Delivery, San Francisco, Cal.

FIRST CLASS all around jeweler, having thorough experience of fine diamond mountings and all kinds of repairing and setting, wishes position will go anywhere; best references. "F., 3632," care Jewelers' Circular-Weekly.

JEWELER, experienced all around man, platinum diamond mounter, new and repair work, can also do setting and designing, wishes position; best of references. Address "Schroeppe," 1105 S. Carolina Ave., S. E., Washington, D. C.

WATCHMAKER, has had 11 years' experience on high grade watches, capable of putting a watch in thorough order, wants position with good firm where only first class work is required. "B., 3630," care Jewelers' Circular-Weekly.

YOUNG LADY desires position with jewelry house; has had seven years' experience and is capable of filling any position in that line; can furnish first class references. Address "T., 3519," care Jewelers' Circular-Weekly.

A FIRST CLASS watchmaker, 25 years' experience on high grade American and Swiss watches, wishes a steady position; can start at once in vicinity of New York City. Address "K., 3541," care Jewelers' Circular-Weekly.

POSITION WANTED as salesman and engraver by young man of good appearance, 25 years of age, two years' experience, who understands the retail business thoroughly; reference. Address H. P. O'Neil, 411 Franklin St., Johnstown, Pa.

EXPERIENCED locket, brooch, bracelet and chainmaker, very good jobber, can do coloring, smelting and refining, 35 years old, married man, desires position; willing to go west. Address "Honest, 3620," care Jewelers' Circular-Weekly.

YOUNG MAN, 25, can assist at watch work, do plain engraving, jewelry coloring and act as salesman, desires position with good watchmaker, own tools. Address "M., 3557," care Jewelers' Circular-Weekly, 501 Heyworth Bldg., Chicago Ill.

HIGH CLASS MANAGER, can do bench work and engraving, also refractionist; \$100 per month up; south or west; trade winner with stiff references; permanent place wanted. "O., 3598," care Jewelers' Circular-Weekly, 501 Heyworth Bldg., Chicago, Ill.

SITUATIONS WANTED.—Continued

A GOOD, experienced manufacturing jeweler, who understands fine and cheap work, has all models and designs necessary to be used, is looking for a position as a foreman and to take charge of factory. Address "T., 3408," care Jewelers' Circular-Weekly.

FIRST CLASS watchmaker, 30 years' experience, wants position; thoroughly competent on complicated work, railroad watches, adjusting; can take care of repairing department; best New York references. Address "F., 3640," care Jewelers' Circular-Weekly.

BY A FIRST CLASS manufacturing jeweler and diamond setter, also an A1 repairer and all around man; young, sober and reliable, with good recommendation; northwestern States; retail stores only need apply. Address Robert W. C. Pfaeffle, Enid, Okla.

YOUNG MAN, age 22, with three years' experience on letter and monogram engraving, also some experience in selling in retail jewelry store, wishes a position; first class references; speak several languages. Address "L., 3624," care Jewelers' Circular Weekly.

A1 WATCHMAKER and graduate optician would like a position in good town in Colorado; have good position, but wife's health demands change; will come on 30 days' trial; best of reference; have tools and trial case; wages, \$22.50 per week. J. T. Little, 317 S. 3d St., Independence, Kans.

WANTED, by a young woman, a position with either a wholesale silver house or as manager of the silver department in a jewelry business; can make herself useful in any or all departments; 12 years' experience; best references; location immaterial. Address "P., 3595," care Jewelers' Circular-Weekly.

YOUNG MAN, 24, single, desires permanent position; first class watchmaker, plain engraver and graduate optician; can act as salesman when necessary; own bench and tools, including lathe, etc.; moderate salary; six years' experience; Georgia or Tennessee preferred. Address "J., 3516," care Jewelers' Circular-Weekly.

FIRST CLASS watchmaker, fine letter and monogram engraver and graduate optician; 23 years' experience, five years on railroad watches; several years in present position; do not repair clocks or jewelry; would not go east of Indiana; town, 8,000 to 25,000; first class references. Address "S. J., 3623," care Jewelers' Circular-Weekly.

Help Wanted.

AUCTIONEER WANTED; live man for jewelry store, busy thoroughfare, desirable stock. Rundback Bros., 2196 Third Ave., New York.

WATCHMAKER. First class workman, one who can engrave preferred; salary and percentage; steady position, A. Hawkins, 727 Eighth Ave., New York.

WANTED, salesmen to sell new patented safety watch guard on commission basis; reference required. Address "M., 3592," care Jewelers' Circular-Weekly.

WANTED, a first class watchmaker to take care of railroad watches especially; none but competent watchmakers need apply. Alfred Bourgeois, Jackson, Miss.

FIRST CLASS watchmaker and engraver to take charge of watch department; steady position; send references, state age, experience and salary wanted. S. Spitz, Santa Fe, N. M.

MANUFACTURING JEWELER wants young lady, who is competent to pick out stones and has had experience in office of jewelry factory. Apply 7th floor, 64 Fulton St., New York.

SALESMAN WANTED on commission to handle well known high grade silver plated hollow ware line, straight or with another good line. Address "R., 3629," care Jewelers' Circular-Weekly.

WANTED, young man with store experience, to do watch, clock and jewelry repairing, also engraving; permanent position; good salary. Address "Boston, 3646," care Jewelers' Circular-Weekly.

WANTED, a first class watchmaker, jeweler, plain engraver, also optician, one who can wait on trade; must have good references; steady position; state salary wanted. D. M. Rinaldo, Hot Springs, Ark.

ENGRAVER, first class, to take charge of engraving department; one who can do chasing, enamel cutting and designing; must be sober and industrious. E. H. Warnke & Co., Enterprise Bldg., Milwaukee, Wis.

WANTED, first class engraver, one who can do either jewelry or watch repairing, for large southern city; good salary for right party; must have best references. Apply Rosenbaum & Adler, 65 Nassau St., New York.

WANTED, first class watchmaker, optician and engraver; permanent position to the right man in one of the growing cities of the southwest; population about 20,000. Address "A1, 3524," care Jewelers' Circular-Weekly.

WANTED, at once, first class manufacturing jeweler and engraver for establishment with power plant; permanent employment, salary, \$25 per week, with increase; with reference. A. Levy-tansky, 108 W. Commerce St., San Antonio, Tex.

WANTED, reliable person or firm to carry high class line of sterling silver flat and hollow ware in the west from Denver to the coast on commission basis; business already established and only such as have personal acquaintance with the trade need apply; line can be carried in conjunction with first class gold jewelry or kindred line. Address with references, "H., 3509," care Jewelers' Circular-Weekly.

Business Opportunities.

FOR SALE; a good, clean jewelry stock for sale at a bargain; must sell at once; good town, no competition. N. Staininger, Vail, Ia.

FOR SALE, jewelry business in interior town, within 100 miles of Detroit; going business. Inquire of Noack & Gorenflo, Detroit, Mich.

J. M. ROSSI, 20 Maiden Lane, New York, desiring to retire from active business, will sell his entire stock of highest grade jewelry amounting to about \$2,000.

FIRST CLASS De Lange refractometer and also fine line of up-to-date optical goods, decided bargain, must sell quick regardless of price. O. C. Radder, Seneca Falls, N. Y.

FOR SALE, the patent right to manufacture a roller jewel setter that will set a roller jewel in 30 seconds, or will sell the patent outright. S. W. Christine, Bangor, Pa.

A RING FACTORY, doing fine work, and well equipped; a close price will be considered for cash offer; write if interested. Address "N., 3290," care Jewelers' Circular-Weekly.

FOR SALE, on account of sickness, an enameling shop for jewelry, established for 25 years; would also accept a competent man for partner instead; location, Newark, N. J. Address "E., 3448," care Jewelers' Circular-Weekly.

FOR SALE, jewelry store, town of 8,000, increase of 4,000 in Summer, 30 miles from New York City, suitable for first class watchmaker, German preferred; write for further particulars. Address "A. D. T." 1037 Sixth Ave., New York.

IF YOU HAVE a surplus stock of diamonds, watches or jewelry, send them to me and I will send cash for same; all business strictly confidential. E. Noel, 552 E. 46th Place, Chicago, Ill.

DO YOU NEED MONEY? If so, send your diamonds and watches to me and get quick and liberal returns; highest cash prices paid for entire jewelry stocks; will send our representative if necessary; business confidential; National Bank references. H. Schwartz, 807 Chicago Savings Bank Building, Chicago, Ill.

DO YOU WISH TO RETIRE? Why not turn your entire store or surplus stock into cash? We pay the highest prices, also advance liberal cash amounts on stocks; communicate with us before consulting others; we act quick and strictly confidential. Brooklyn Purchasing Syndicate, 608 Broadway, Brooklyn, N. Y., Telephone, 2328 Williamsburg.

FOR SALE, the well known plant of A. Lounsbury & Son, in full running order, with low rent, consisting of machinery, tools, dies, cutters, hydraulic press, drop presses, foot presses, upright drills, stock, office fixtures, safes, etc.; this plant is thoroughly equipped to make diamond mountings of all descriptions, both heavy and light, as well as fancy jewelry. Apply to Wales B. Lounsbury, 9 Maiden Lane, New York.

For Sale.

FOR SALE, jeweler's safe, inside dimensions, 24 x 27 x 30. Ford & Carpenter, 2 Maiden Lane, New York.

TWO WATCHMAKERS' benches, cabinet, foot wheel, trial case and jeweler's lathe. Room 404, 81 Nassau St., New York.

FOR SALE, jewelry trunks, plain trays and fine silk lined trays. The Arnstine Bros. Co., cor. 9th St. and Prospect Ave., Cleveland, O.

FOR SALE, good set of watchmaker's tools, including bench, lathe, etc.; fine set for a beginner. Address "S., 3600," care Jewelers' Circular-Weekly.

FOR SALE, platform scales, two dynamos for coloring room, three ft. press, gas furnace, electric furnace, rotary shears, four scratch brush heads, bench vise, air pumps. The Chas. M. Robbins Co., Attleboro, Mass.

FOR SALE, two fine cherry show cases, 10 feet long, with tables, cost \$125 each, will sell for \$40 each; three cases about 6 feet long, three wall cases and drawers, perfect order, one jeweler's safe, 5 feet high by 4 1/2 feet wide, cost \$375, will sell for \$140. C. G. Roehat, 75 Montgomery St., Jersey City, N. J.

To Let.

PART of desirable office occupied by silversmiths, Room 308, 320 Fifth Ave., cor. 32d St., New York.

PART OF OFFICE, fine light, suitable for engraver, designer or stone setter. Apply, 2 to 4 P. M., Room 412, 38 W. 33d St., New York.

PART OF OFFICE, with large front window, desk room and bench room, including bench. I. Robinson, diamond setter, 12 John St., New York.

PART OF OFFICE, good light, suitable for engraver, designer, stone setter or watchmaker. Apply Room 71, 12 to 16 John St., New York.

Wanted to Purchase.

WANTED, jeweler's power rolling mill, one with good size rolls; must be in first class condition and reasonable in price. Address with particulars to Edward Todd & Co., 1 W. 34th St., New York.

WE WANT to purchase a good paying retail jewelry business; we have \$10,000 to invest; city must not be less than 25,000 and good climate; give amount of business done, amount of repair work and full particulars in first letter. Address "U., 3544," care Jewelers' Circular-Weekly.

(Special Notices continued on page 76.)



The above TRADE MARK is well known to you, because it is on every watch and watch movement made by the LANGENDORF WATCH CO.

The more of our large line you carry in stock, the more profitable and satisfactory are

YOUR SALES

Perfect Interchangeability of parts renders repairing easy.

Do not accept substitutes, but insist upon getting the genuine L. W. Co. make. It's far the cheapest after all, as the quality is such you may

DEPEND UPON

If your jobber cannot supply you with

THE RIGHT KIND of GOODS

write to the Sole Agents for the United States,

AMERICAN-SWISS WATCH CO.

1 Maiden Lane, New York
CUSHMAN BUILDING

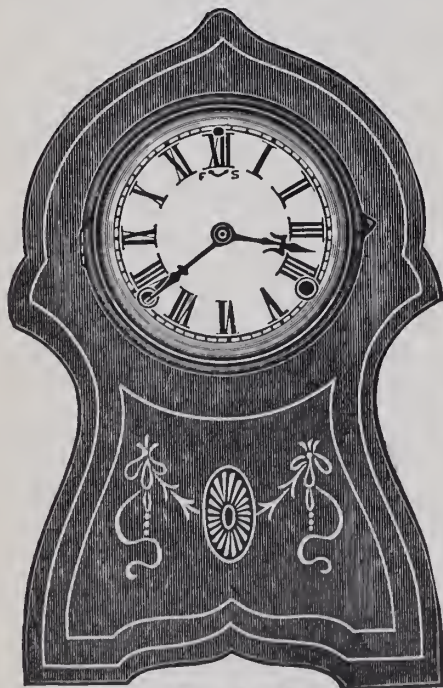

MANCHESTER
Height 13¾ in. Width 8¾ in.

SESSIONS CLOCKS

Superior Finish
Popular Prices

We have added a number of fine marqueterie cabinet clocks to our line which will interest you.

*The Sessions Clock
Company*

FORESTVILLE, CONN., U. S. A.

New York Salesroom, 37 Maiden Lane

Special Notices.

(Continued from page 75.)

Wanted to Rent.

WANTED, a place with bench and rollers for jeweler. Address "I., 3612," care Jewelers' Circular-Weekly.

Lost.

LOST, four pearl shaped pieces of coral, Thursday, March 5, in the vicinity of Maiden Lane, John and Nassau Sts.; reward for the return of same to McTeigue, Manz & Co., 31 W. 31st St., New York.

Miscellaneous.

I CAN TELL you how to advertise and pull business, all the year; I'll prove it first and then furnish the idea and material to only one dealer in a town. Address "W., 3616," care Jewelers' Circular-Weekly.

S. F. MYERS BLDG.
47-49 Maiden Lane, N. Y.

For Rent

A few choice, light and very desirable offices

Moderate Rentals

Details of

J. A. MYERS

On Premises

Practical Course in Adjusting

Published Price, \$2.50

Special Reduced Price, \$1.50, Postpaid

All Jobbers, or

Jewelers' Circular Publishing Co.

NOTICE TO THE LIVE JEWELER WE HAVE THEM

Hampden, Springfield, Rockford, Hamilton, Elgin and Waltham movements in all sizes and grades. Railroad movements a speciality. Drop us a postal and we will show you how to save big money.

THE EVESON CO. (Not Inc.)
503 Heyworth Bldg. CHICAGO, ILL.

CHARLES M. PRIOR, Designer

We have ready many new designs. Call or write. Etching is more popular than ever and we do it in the finest style.

'Phone 1639 Gramercy

24-26 East 21st St., NEW YORK



THE ROCKFORD WATCH
for ALL CLASSES

"True Time for a Life Time."

Rockford Watches

The Most Profitable and Satisfactory
 Watch for the Legitimate Jeweler.

WRITE TO-DAY FOR PRICE LIST AND ADVERTISING MATTER

ROCKFORD WATCH COMPANY, ROCKFORD, ILL.

GEO. KUEHL & CO.

80-82 Wabash Avenue, CHICAGO, ILL.

Manufacturers and Importers of

BLACK FOREST CLOCKS

WITH

TRADE MARK



Cuckoo Clocks, Quail and Cuckoo Clocks, Westminster Mantel Chime
 Clocks, Quarter-Hour Strike Clocks, Novelty Clocks, Four
 Hundred-Day Clocks, Traveling Clocks, Alarm Clocks,
 Music Clocks, Barometers, Chronoscopes

WORKS: SCHONACH AND HORNBERG, Bad. Schwarzwald, GERMANY

20
Years

H. E. GLENDORE & CO.

807 Chicago Savings Bank Building

CHICAGO, ILLINOIS

20
Years

Do You Want
M O N E Y
In Your Cash Box?

READ!!

We guarantee you against loss; your reputation remains the same after we finish. We never misrepresent the quality, and you can always depend on us to fill our engagements. We will make your sale and **POSITIVELY GUARANTEE** that our **NEW SYSTEM** will produce the required results. Wire or write for date.



Do You Want
M O N E Y
In Your Cash Box?

THAT IS *WHY* WE HAVE THE CONFIDENCE OF THE *MANY JEWELERS* WHOM WE HAVE SERVED; AND ACCOUNTS FOR THE EVER-INCREASING DEMAND FOR OUR SERVICES.

A \$40,000 SALE

To My Brother Jewelers:
My sale, which was conducted by H. E. Glendore & Co., was one of the most pleasant surprises of my business career, surpassing all my expectations. Yours,
A. KAEMPFER.

A \$7,000 SALE

I moved to Amarillo, Texas, and opened there Dec. 15, 1907. Mr. Glendore made my sale the following month (January), opening sale Jan. 11, 1908, selling over \$7,000 and averaging 5 per cent. profit, under the most difficult circumstances. Many thanks to him.
E. I. PITTMAN & SON.

A \$10,000 SALE

My sale made in last month, February, 1908, by H. E. Glendore and M. L. Jalonack, was in every way satisfactory. My guarantee with them was for them to get me 80 cents on the dollar. But they made my stock bring me dollar for dollar, above expenses. H. L. MORRISON,
Pittsburg, Kan.

A \$20,000 SALE

To anyone seeking the service of a first-class auctioneer, I can sincerely and truthfully recommend Mr. Glendore, who has made a friend of myself, and his entire attendance, and is a hard worker for his employer, who made good margins on his sales, and highly satisfactory to me. This sale was a surprise. I beg to remain most friendly,

JOE FRIEDLANDER,
Memphis, Tenn.

WE HAVE A COMPLETE NEW SYSTEM FOR CONDUCTING SALES.

AN \$18,000 SALE

Mr. H. E. Glendore has my entire thanks as his sale was an entire success from all business standpoints.
J. PETROVITSKY,
Salt Lake City, Utah.

Write for our Special Terms

Will Pay Cash for Your Stock

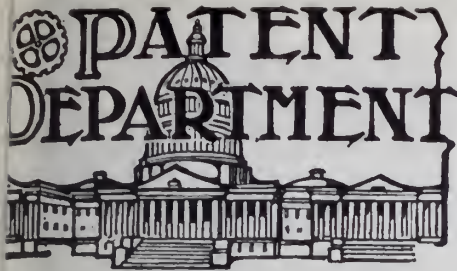

WHICH IS CONTAINED A LIST OF THE LATEST PATENTS GRANTED BY THE UNITED STATES AND GREAT BRITAIN, THE UNITED STATES PATENTS THAT HAVE EXPIRED AND THE REGISTERED TRADE-MARKS.

UNITED STATES PATENTS.

ISSUED MARCH 3, 1908.

880,675. PROCESS ALARM-CLOCK. WILLIAM J. LATCHFORD, Chicago. Filed March 11, 1907. Serial No. 361,793.

A process alarm clock comprising an electric circuit and an alarm device therein; a fixed dial also in the circuit having its subdivisions each provided with means for receiving a contact pin; a dial concentric with the fixed dial mounted for

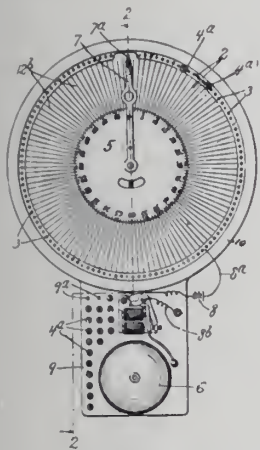

rotation with the clock train; a contact finger carried by the rotating dial, said rotating dial being graduated commencing at the location of the finger to correspond with the subdivisions of the fixed dial, and distinguishably marked contact pins adapted to be applied at will to any subdivision of the fixed dial.

880,897. WATCH-BEZEL. Gov G. LLOYD, Donaldson, Minn. Filed March 13, 1907. Serial No. 362,122.

A watch case and bezel comprising the outer rim and main part of the bezel, having a larger and a smaller screw-threaded offset and provided with a beveled seat for the glass, the glass resting at its margin on said beveled seat, a follower outwardly

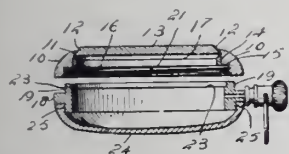

beveled at its outer margin, screwed into said smaller offset and bearing at its outer edge on the extreme margin of the glass, the ring or case-center provided with an external screw-threaded offset to adapt it to be turned into the larger offset of the outer rim, and having an internal offset 23, combined with the casing for the watch-works provided with a rim resting on the said offset 23 and bearing against the inner side of the follower.

881,065. JEWEL-BAR. HENRY W. FISHEL, New York, assignor to himself and Theodore H. Fishel, copartners trading as Fishel, Nessler & Co., New York. Filed March 16, 1907. Serial No. 362,660.

An integral jewel bar recessed to form a plurality of closely adjacent jewel-receiving sockets, walls surrounding the sockets and terminating in

thin extremities continuons with the lateral surfaces of the bar, and jewels located in and closely fitting the sockets, the thin extremities of the walls



being forced inward over the jewels and securing the jewels in place.

881,066. JEWEL BAR. HENRY W. FISHEL, New York, assignor to himself and Theodore H. Fishel, copartners trading as Fishel, Nessler & Co., New York. Filed May 13, 1907. Serial No. 373,447.

A jewel bar comprising a body provided with jewel-receiving sockets, a thin wall at one side of

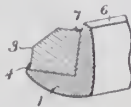

each socket and beading at the other side of each socket and jewels secured in the sockets, the thin wall being burnished down on the jewels.

DESIGNS.

339,164. PIN OR BUTTON HEAD. DAVID P. BARRY, New York. Filed Jan. 4, 1908. Se-



rial No. 409,362. Term of patent 7 years.

UNITED STATES TRADE-MARKS.

[The following trade-marks have been adjudged entitled to registration under the Act of Feb. 20, 1905, and are published in compliance with Section 6 of said act. Said section provides:

"Any person who believes he would be damaged by the registration of a mark may oppose the same by filing notice of opposition, stating the grounds therefor, in the Patent Office, within 30 days after the publication of the mark sought to be registered, which said notice of opposition shall be verified by the person filing the same before one of the officers mentioned in Section 2 of this act. If no notice of opposition is filed within said time the commissioner shall issue a certificate of registration therefor, as hereinafter provided for."

Marks which are stated to have been "Used 10 years" are registrable under the last proviso of Section 5 of said act, which is as follows:

"And provided further, that nothing therein shall prevent the registration of any mark used by the applicant or his predecessor, or by those from whom title to the mark is derived, in commerce with foreign nations or among the several States, or with Indian tribes, which was in actual and exclusive use as a trade-mark of the applicant or his predecessor from whom he derived title for 10 years next preceding the passage of this act."

PUBLISHED MARCH 3, 1908

Ser. No. 31,845. (CLASS 27. HOROLOGICAL INSTRUMENTS.) NETH THOMAS CLOCK CO., New York. Filed Dec. 19, 1907.



Particular description of goods.—Clocks.

Ser. No. 32,160. (CLASS 28. JEWELRY AND PRECIOUS METAL WARE.) ARTHUR L. BAILHACHE, Racine, Wis. Filed Jan. 10, 1908.



Particular description of goods.—Jewelry for personal wear, bowls, spoons, and cups of precious-metal ware.

TRADE-MARKS REGISTERED MARCH 3, 1908.

68,029. CHAINS FOR PERSONAL ADORNMENT. D. F. BRIGGS CO., Attleboro, Mass. Filed Nov. 18, 1907. Serial No. 31,230. Published Dec. 31, 1907.

BRITISH PATENTS.

(ABRIDGMENTS OF SPECIFICATIONS, 1906, FROM The Illustrated Official Journal.)

ISSUE OF FEB. 19, 1908.

24,014. CLOCKS. E. WUSTHOFF, Hamburg, and M. KRIMNITZ, Magdeburg, both in Germany. Oct. 29.

Alarms.—The ordinary mechanical alarm is repeated at intervals, preferably of a quarter of an hour, until the spring has run down. The wheel d which actuates the escapement e is locked by

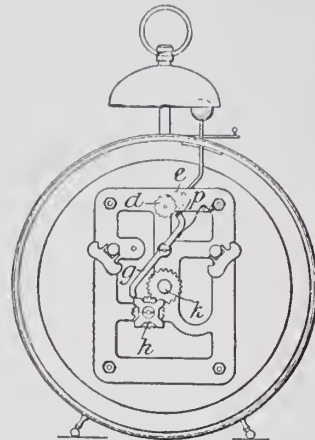

the engagement of a pallet p on the spring-actuated lever g, which is controlled by the four-toothed wheel h, geared to the minute-hand arbor k.

24,216. STUDS, ETC. A. MOLLER, Grünwald, Thalsperren, Cantine, and F. KRATZER, Gablonz, both in Bohemia. Oct. 30.

In a stud, detachable button, etc., having a revolving bolt 1 in a hollow shank 4, the bolt is

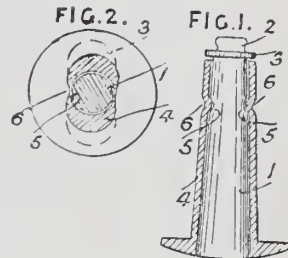

conical, with a circular section, and is notched at 5 to engage projections 6 within the elliptical spring shank, so that rotation is prevented during insertion in the buttonholes. The bolt has a bush 2 and elliptical collar 3.

Complete specifications accepted Feb. 12, 1908. 1907.

2,965. OPHTHALMOMETERS. GOWLLAND & GOWLLAND.

8,813. STUDS. PALMER.

14,005. STUDS. MORTON.

17,717. ELECTROPLATING. COWPER-COWLES.

23,705. BRACELET. SPEIDEL.

Applications filed Feb. 3 to Feb. 8, 1908.

2,339. HAT-PIN. A. J. FRASER, Glasgow.

2,341. TIME-RECORDER. W. M. LLEWELLIN, Bristol.

2,487. BUCKLE. W. J. GORDON and ROBERT MCPHERSON, London. Complete specification.

2,545. BUCKLE. THOMAS WALKER, THOMAS WALKER, JR., ALFRED WALKER and A. E. WALKER, Birmingham.

2,630. BROOCH. E. A. MARSH, Birmingham.

2,659. HAT-HOLDER. FRANZ LIMER, London.

2,691. HAIR-PIN. F. H. ADDIS, London.

2,715. COLLAR BUTTON. HARTVIG DUNCAN, London.

2,747. FINGER RING. WRIGHT & PERRY and H.

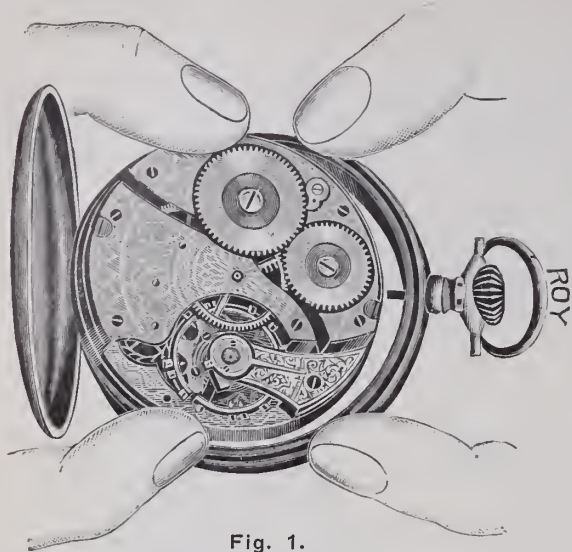

Fig. 1.

The
Ægis Case
 Patented

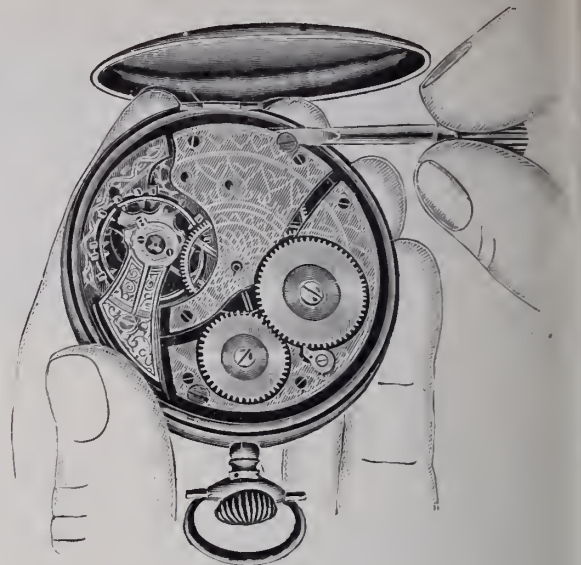

Fig. 3.

¶ The Ægis is a new creation in gold case making. The center and bezel are in one. Instead of having the ordinary Cap, this case is provided with a rigid metal movement Cup, held friction tight in position. This Cup gives protection to the movement such as cannot be secured with the conventional jointed cap, while dust is thoroughly excluded from the front by means of the one piece center and bezel.

¶ To fit movement, first properly adjust the hands; then pull out crown as usual, and insert movement from back of case, (see fig. 1). After winding square is properly fitted, the movement should be pressed down, so that it will be held in proper place by the spring in the case center. The movement cup should then be fitted.

¶ To take out movement, remove the movement cup (shown in fig. 2), by raising it near the pendant; pull out crown to release the square; lift out movement by means of case screw nearest joint (see fig. 3); withdraw movement from square and case.

Made only
 by



Fig. 2

Made only
 by

ROY WATCH CASE COMPANY

SAN FRANCISCO OFFICE
 704 Market Street

21-23 Maiden Lane
 NEW YORK

- T. PERRY, Birmingham.
 2,821. CUFF RETAINERS. C. W. GLANVILLE, London.
 2,888. SLEEVE-LINKS. SAUL BETTS, London.

UNITED STATES PATENTS THAT HAVE EXPIRED.

[Reported especially for THE JEWELERS' CIRCULAR-WEEKLY by R. W. Bishop, Patent Attorney, Washington, D. C.]

Issued Feb. 24, 1891.

- 447,002. COFFEE-POT. FLORA L. BROWN, Chicago.
 447,105. INDEPENDENT ELECTRIC CLOCK. W. J. DUDLEY, Everett, Mass.
 447,128. BIFOCAL SPECTACLES. G. H. CLINE, Jersey Shore, Pa.
 447,185. CORKSCREW. CARL HOLLWEG, Barmen, Germany.
 447,197. PENHOLDER. THOMAS NANCE, Shelbyville, Tenn.
 447,249. SEPARABLE BUTTON. R. H. LEWIS, Providence, R. I., assignor to Albert Eddy, same place.
 Designs issued Feb. 26, 1901, for 7 years.
 34,124. BADGE. IKKO MATSUMOTO, Chicago.
 34,125. CHARM. W. S. BICKLEY, Chester, Pa.
 34,129. COVERED DISH. GUSTAVE VOGT, Limoges, France.
 34,130. DISH. GUSTAVE VOGT, Limoges, France.
 Design issued Aug. 23, 1904, for 3½ years.
 37,104. CLOCK OR PICTURE FRAME. A. E. SELIGER, St. Paul, Minn.

Issued March 3, 1891.

- 447,405. DEVICE FOR MAKING EAR-WIRES. SIMON GOLDNER, Brooklyn, N. Y.
 447,473. WATCH CASE SPRING. JOSEF PALLWEBER, Furtwangen, assignor to Sigmund Stern, Frankfurt-on-the-Main, Germany.
 447,474. WATCH. R. L. PEABODY, New York.
 447,493. CUFF-HOLDER. H. D. MUGER-DITCHYAN, Chicago.
 447,502. MANUFACTURE OF JUG-TOPS. HOMER WRIGHT, Pittsburg, Pa.
 447,533. CUFF-HOLDER. B. R. BACON, East Orange, N. J., assignor to himself and T. R. Scully, Buffalo, N. Y.
 447,622. ORNAMENT. L. B. PRAHAR, Brooklyn, N. Y.
 447,644. FORK-GUARD. STEPHEN NOWILL, Constantinople, Turkey.
 447,663. HOLDER FOR STAMPS. B. F. CARPENTER, Roselle, N. J.
 447,692. BRACELET. A. W. MAGERIANS, New York.
 447,736. CLASP. J. H. MURCH, Boston, Mass., assignor to F. J. Gilbert, same place.
 Designs issued March 5, 1901, for 7 years.
 34,154. PIN. G. A. WHITING, North Attleboro, Mass., assignor to the Greenleaf & Crosby Co., Florida.
 34,155. RING. IKKO MATSUMOTO, Indianapolis, Ind.
 34,157. SPOON-HANDLE. H. H. CURTIS, North Attleboro, Mass.
 34,159. TEA-POT. F. W. VAN BERGH and G. W. STYVER, Rochester, N. Y., assignor to the Van Bergh Silver Plate Co., same place.
 34,160 and 34,161. CLOCK CASE. E. M. JENNINGS and C. S. MOSMAN, Bridgeport, Conn., assignors to the Jennings Bros. Mfg. Co., same place.
 34,162. DIAL. G. M. CHERICATI, New York.
 34,165. FLASK. A. D. GEORGE, Chicago.

C. E. Campbell, Panora, Ia., has been improving the appearance of his store by painting, decorating and installing new counters and show cases.

Lynch & Hannifin and Towle & Winterhalter, Butte, Mont., have consolidated and will hereafter be known as the Towle, Winterhalter, Hannifin Co., with headquarters in the Goldberg block.

LETTERS TO THE EDITOR.

Treasurer Bernau of the A. N. R. J. A. Against Proposed Railroad Watch Inspection Laws.

GREENSBORO, N. C., Feb. 29, 1908.

Editor THE JEWELERS' CIRCULAR-WEEKLY:

As an officer of the American National Retail Jewelers Association I have heard considerable comment on the resolutions concerning the so-called Watch Inspection bill that we passed at the last meeting of our organization, and, if you will permit me to take up a little space in your publication, I would like to make clear my own position in this matter.

Personally, I think the whole action was a mistake. To my own personal knowledge it was never read verbatim on the floor, was handed to some one of the committee of resolutions, which in turn recommended it, stating that each member knew what the resolution was; therefore, it was, so to speak, railroaded through the convention. Next morning there appeared in the Chicago *Tribune* an article attacking one particular concern, claiming that our convention had done this and that the resolution was aimed at this house.

Now I know this was not the intention of the executive committee, nor do I believe it was the intention of the majority who voted for the resolution to attack any particular concern or concerns.

The subject was discussed at great length recently at our executive committee meeting at Cincinnati recently, but as some of the members thought it better to let the matter rest as it stands, the following resolution, prepared by myself and Max Jennings, was tabled:

"The executive committee regret very much that matters relating to the inspection of watches have drifted into the channels they did, which we do not believe were intended by the association, nor authorized by the officers. Whereas, The railroad men individually complained that they were discriminated against in the matter of watch inspection, collectively later stated that they were satisfied with the rules, We recommend to the several State associations that no action be taken in this matter until such time when all the interests are united on what is required, and that all chief inspectors be asked to come to an agreement as to a minimum standard of watches on all their roads."

I am sorry this resolution did not pass at our meeting, but trust that the subject will not be allowed to drop and will come up at the next meeting for a thorough discussion. It is my idea that the association had better not have anything to do with legislation along these lines, because it would only be detrimental to our own interest and would not help the railroad men or the general public. Watch inspection as carried on by the big railroad systems now gives excellent results, both to the railroad and the employes and affords a good demand to the jewelry trade for high class watches.

As the railroad employe has to buy no tools or anything but a good watch, he certainly has no cause for complaint; in fact, officially his organization says he has no complaint, and I do not think therefore it is

the part of the jeweler to take up for him a fight which he does not seem to wish waged. Yours very truly,

R. C. BERNAU,
 Treasurer American National Retail Jewelers Association.

Cleveland.

Webb C. Ball and S. Y. Ball spent several days last week in Chicago.

Wm. Dehnel and wife, Sandusky, O., were in this city last Thursday evening.

W. A. Smith and E. C. McKeen, representing the Waltham Watch Co., have spent the past few days in Cleveland and surrounding towns.

The following out-of-town dealers were in Cleveland during the past week: C. M. Wilson, Salem; Nelt Barr, Ashland; L. W. Wyckoff, Chagrin Falls; T. H. Park, Mantua; Geo. F. High, Medina; Robert Miller, Lorain, O.

Frank N. Gear, who is conducting a railroad watch business from an office in the Cuyahoga building, was in Columbus recently. Mr. Gear seems to be unsupported by Ohio retailers in his effort to secure legislation changing the present methods of conducting railroad time service. At a recent legislative committee hearing on the matter, no one appeared in support of the measure except Mr. Gear, and he was asked by several of the committeemen present what was responsible for his particular and sustained interest in this bill.

This city is the headquarters of the Brotherhood of Locomotive Engineers and the Brotherhood of Railroad Trainmen, both very influential organizations of railroad men. Their chiefs and high executive officers have, within the past few weeks, been in conference with operating officials of the railroad companies at different points, and it is reported that definite and most satisfactory assurances have been received from the companies that there will be no reduction in pay of any of the operating employes. The assurance means business for jewelers, as well as other merchants.

Egyptian Goldsmiths.

"EGYPTIANS made the finest jewelry the world has ever had," said Professor Max Mueller, the celebrated Egyptologist, in another of his series of lectures on Egypt at the University of Pennsylvania Museum recently. "Their goldsmiths were more skilful than even those of the present day. In those days, when a customer took gold to a smith to be worked with into a necklace or bracelet, he stayed there to watch him, so that none of the gold should be stolen."

Doctor Mueller's subject was "The Art of Ancient Egypt." He traced the history of it from the earliest times, showing its subservience to architecture. "One of the dominant features of the Egyptian art," said the lecturer, "is humor, and there are many amusing examples of this."

Frank Horan, formerly of Lake City, Minn., has accepted a position in a store at Casselton, N. Dak.

Waltham Watches

The history of the WALTHAM WATCH COMPANY is the history of watch manufacturing in America. More than half a century ago this Company introduced a new principle in the construction of watch movements, and has ever since applied the most advanced methods, producing always the best watches in the world. The WALTHAM WATCH COMPANY has built within its own walls the marvelous machinery employed in making the 15,000,000 Waltham watch movements now in use

Waltham Watch Company

WALTHAM, MASS.

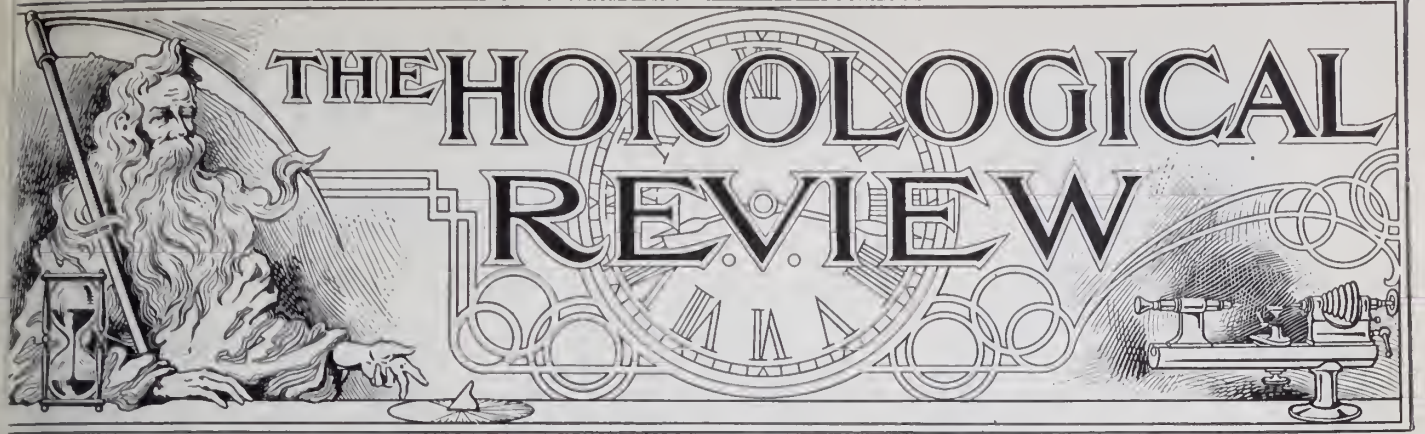

THE HOROLOGICAL REVIEW

Synchronization of Clocks by Gas Pressure.

By R. BONNIKSEN, in the *British Horological Journal*.
(Continued from issue of March 4.)

It has remained for two local inventors, F. A. Chandler, jeweler, of Leamington, and Bahne Bonniksen, a Danish gentleman who has made his home at Coventry, to perfect a system—or, to be strictly accurate, two systems—which are not open to this objection. The main point of difference between them and the older systems is that, whereas the latter required wires to be installed for their separate use, Messrs. Chandler and Bonniksen derive the current which they use from the electric light mains, so that any user of electricity, whether for light or power, can have his clocks synchronized at a cost which is far below the lowest figure possible under either separate wiring or pneumatic systems.

A representative of the *Chronicle* visited Mr. Chandler's place of business in Victoria Terrace the other day, and the inventor very courteously explained the leading features of the system to him at some length. Stripped of technicalities, the system of working is this: There is a master clock at the place where the current is generated—in Leamington the Midland Electric Light and Power Works—and this clock, which is of superior make, is carefully regulated so as always to record the correct Greenwich time. Any number of clocks fitted with the special apparatus which Messrs. Chandler and Bonniksen have invented can be kept going in unison with this one clock by means of the subtle force communicated to them through the electric company's mains, and they require neither winding nor setting to time. Once in 24 hours a signal goes from the master clock to every member of the horological clan of which it is the head, and the hands shift backward or forward on the dial—according as each one has lost or gained during the day. The clocks are always wound up, and always right—or so near to being right that the error is inappreciable.

Our representative asked Mr. Chandler if there was any limit to the number of clocks which might be synchronized by this system, and his reply was in the negative. "Wherever the current for electric lighting is carried," he said, "we can work our clocks. The amount of current we use is infinitesimally small—so small that the most delicate meter in existence would not register it. The wonderful thing is that

we can handle these great cables and the strong currents they carry, and make them operate such delicate machinery as clock-work."

Mr. Chandler and Mr. Bonniksen have quite recently perfected another invention. It may be briefly defined as a system of automatic regulating which operates gradually instead of spasmodically—that is to say, the process of synchronization is always in progress, instead of being accomplished instantaneously once in 24 hours. The advantages of such a system are obvious, and Mr. Chandler believes there is a great future for it in large hotels and other establishments, where many dials are worked by one central master clock.

Mr. Chandler has several men engaged in manufacturing the clocks, many of which are now working in Leamington, and are giving entire satisfaction to the customers of the company which has been formed to exploit the patents. But such an invention is certain to be heard of over a very much wider area than that of this borough before long. There are assuredly great possibilities before it, and Leamingtonians will probably have cause in the not distant future to feel some legitimate pride in the fact that a townsman of their own played so prominent a part in such an ingenious and beautiful application of electrical science to the needs of our complicated commercial life."

(THE END.)

Two Devices for the Rapid Winding of Watches.

THE question was asked in a French exchange whether there existed an apparatus by means of which the winding of stem-winders could be effected more rapidly than with the fingers. In the reply he was told that among the German patents the description of a device had been found, which is reproduced herewith (Fig. 1).

This contrivance was intended by the inventor for this special purpose. It was at the same time to serve as a place to hang up the watch. Its construction is as follows: A strip of rubber, G, slightly hollowed out in the direction of its length, is fixed to the wall between two pieces of wood, H H. The upper portion, H, only serves for ornament, while the lower circular disk, trimmed with plush, is where the watch is hung up on the hook, h.

The whole has the appearance of a pendulum, and our cut (Fig. 1) shows it in about one-third actual size.

The busy man to whom the winding be-

tween thumb and index finger means too much loss of time only needs to take his chronometer from the hook h, where it had been hanging over night, place the crown or button on the top end of the rubber strip and slide it down to the bottom, when the watch will be fully wound.

The question of the rapid winding of watches is not devoid of interest, especially in stores or factories where every day many watches are under observation. The rubber strip just described placed flat on the work-

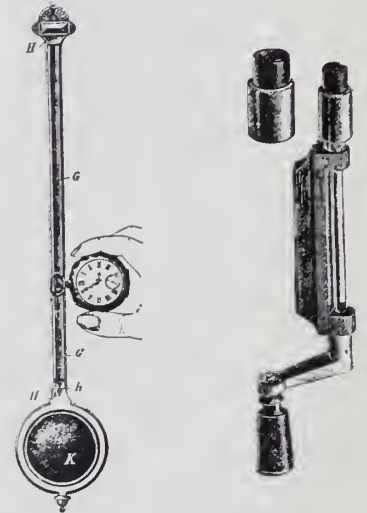

FIG. 1.

FIG. 2.

bench will render good service, and has probably been actually used for this purpose.

There is, however, in the market a tool specially designed for factories, etc. As will be seen from the illustration (Fig. 2) it consists of a sort of mainspring winder, the chuck of which presents at its extremity a cavity provided with rubber. The button of the watch to be wound is placed in this cavity and the handle or crank of the tool turned, thus quickly winding the watch without any danger of forcing out the crown, or button.

The tool comes with two chucks of different size, suitable for large and small watches.

It is said that the Democratic leaders of Delaware are beginning to take notice of the boom of Milliard F. Davis, a well-known jeweler of Wilmington, for the nomination of governor. Mr. Davis has not announced his candidacy, but his friends have been enthusiastic in suggesting that the jeweler have the State ticket.

The G. M. Wheeler Grade

ELGIN WATCH

In 3 Sizes

Popular when it was made only in the 18 size—in great demand now in the thin model 16 and 12 sizes.

Advertised so widely everyone knows of it—priced so reasonably everyone wants it—sells so rapidly every jeweler must have it.

See jobbers list for prices
or write the Company.

*Send for Elgin art booklets,
"Timemakers and Timekeepers" and "The Watch."*

ELGIN NATIONAL WATCH COMPANY,

Factories : Elgin, Ill., U. S. A.
General Offices : 131 Wabash Ave., Chicago.
New York Office : 11 John St.
San Francisco Office : 704 Market St.

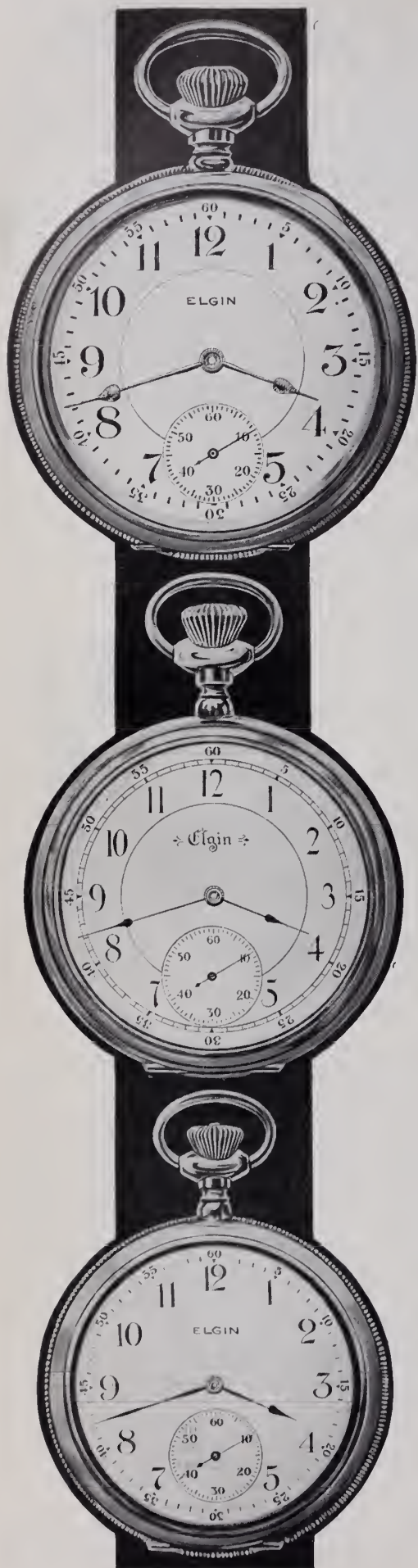

RESULTS OF KEW TRIALS FOR 1907-1908

LONDON, Feb. 29.—The result of the Kew trials is by no means satisfactory to the British watch trade. The first four positions in the list of the 50 best watches submitted were secured by Swiss manufacturers. Patek, Philippe & Co. (who, by the way, also head the Geneva Observatory list

with four watches and were awarded the first prize) head the Kew list with two watches, which were awarded respectively 92.2 and 91.9 marks. Messrs. Vacheron & Constantin have two watches placed third and fourth and Charles Frodsham, an old-established and famous English house, oc-

cupies the fifth position with a Tourbillon, which has been awarded 89.6 marks. Kar-ruselus, which have so far figured so largely in the list, are represented only by six.

The report of the superintendent, which came into my hands to-day, states that 26 fewer watches were sent for trial, that the percentage of movements obtaining A certificates is smaller, while the average number of marks obtained by the listed 50 is also lower. On the other hand, there have been an unusually large number of marine

KEW TRIALS FOR 1907-RATING OF WATCHES AND CHRONOMETERS.

Performances of the watches which obtained the highest number of marks during the year.

Table with columns: Watch deposited by, Number of Watch, Escapement, Balance spring, etc., Mean daily rate (Pendant up, Pendant right, Pendant left, Dial up, Dial down), Mean variation of daily rate, Mean change of rate, Difference between extreme gaining and losing rates, Marks awarded for (Daily variation, Change of rate, Temperature compensation), Total Marks.

In the above List the following abbreviations are used, viz.: S.r. for single roller; d.r. for double roller; g.b. for going barrel; s.o. for single overcoil; d.o. for double overcoil spring; + for gaining rate; - for losing rate.

Ladies' Open Face Watch Cases

Jas. Boss Stiffened Gold
Guaranteed for 25 years



F-016



Trade-Mark
in back.



Trade-Mark
in cap.



F-015



F-3043

¶ The Queen Style is the smallest case that can be built over an O size movement.

¶ Swivel Pendant. The best for use with Chatelaine Pin.

¶ French Bow. Secure and Artistic.

¶ Plain Polish, Satin Finish, Roman. For monogram work.

¶ Engine Turned Shield, Spot and Drop Shield; Fancy Engraved in great variety, and Diamond Set—single Stone Star, etc.

¶ Jas. Boss 25-year O size, open face cases, fitted with 7-jewel movements, make reliable watches at a popular price.

¶ Sold by all leading Jobbers.



F-0115



F-3450

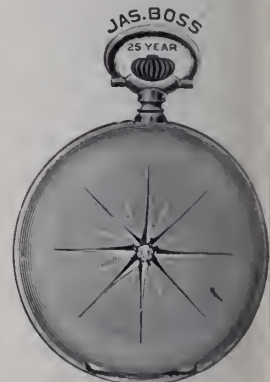

FD-544 1/2

THE KEYSTONE WATCH CASE CO.

PHILADELPHIA

NEW YORK

BOSTON

CHICAGO

CINCINNATI

SAN FRANCISCO

TABLE II.—HIGHEST MARKS OBTAINED BY "COMPLICATED" WATCHES DURING THE YEAR 1907.

Description of Watch.	Number.	Name.	Marks awarded for			Total marks. 0—100.
			Variation.	Position.	Temperature.	
			0—40.	0—40.	0—20.	
Minute and seconds chronograph, minute repeater, perpetual calendar, and moon's phases	2266	J. W. Benson, London	31.1	30.3	14.8	76.2
Minute and split seconds chronograph and minute repeater	09152	Chas. Frodsham & Co., London	32.1	35.7	15.2	83.0
	203155	Stauffer, Son & Co. London	29.9	35.3	16.3	81.5
	203160	Stauffer, Son & Co. London	30.8	36.0	14.4	81.2
	203161	Stauffer, Son & Co. London	30.4	34.6	15.6	80.6
Minute and split seconds chronograph	11733	John Walker, London	28.2	34.4	13.7	76.3
	22603	C. J. H. Marlow, Coventry	32.0	37.9	15.4	85.3
Minute and seconds chronograph	2399	J. W. Benson, London	30.0	35.3	15.2	80.5
	92295	Newsome & Co. Coventry	32.1	30.9	14.5	77.5
$\frac{1}{2}$ second chronograph	203165	Stauffer Son & Co., London	30.0	34.7	16.5	81.3

chronometers sent in for trial during the year, viz., 174. Of these 134 were awarded certificates.

It is noteworthy that in the list of complicated watches Stauffer, Son & Co. again occupy the first three positions for minute and split seconds chronographs. It is remarkable that for three years in succession this firm have retained the three premier positions. They also have a special and singular section in the list for their one-tenth of a second chronograph, which has secured a very high percentage of marks.

In the Greenwich trials for box chronometers Johannsen & Co. head the list and Kullberg, of London, takes the second position. For chronometer watches H. White & Co., of London, are awarded first place and Owen & Robinson, Ltd., of Leeds, the second, J. Player & Son, of Coventry, being placed third and fourth. The official report says:

RATING OF WATCHES AND CHRONOMETERS, 1906.
The number of watches sent for trial this year was 246, as compared with 272 in 1906.

The "especially good" class A certificate was obtained by 49 movements. The high degree of excellence to which attention was called in previous reports has been fairly well maintained, but the percentage number of movements obtaining the especially good class A certificate has fallen somewhat; only four watches obtained 90 marks and upwards, and the average number of marks obtained by the first 50 watches is lower.

The following figures show the percentage number of watches obtaining the distinction "especially good," as compared to the total number obtaining class A certificates: 1895, 16.6; 1896, 30.5; 1897, 28.0; 1898, 22.1; 1899, 26.6; 1900, 35.4; 1901, 35.5; 1902, 31.6; 1903, 42.4; 1904, 50.2; 1905, 44.7; 1906, 47.5; 1907, 43.0.

The 246 watches received were entered for trial as below:

For class A, 155; class B, 55, and for the subsidiary trial, 36. Of these 114 were awarded class A certificates, 44 obtained class B certificates, 29 passed the subsidiary test, and 59 failed from various causes to gain a certificate.

In Appendix IV, to the report of the Observatory Department will be found a table giving the results of trial of the watches which gained the highest numbers of marks during the year. The first two places were taken by the keyless going barrel bar-lever watches, Nos. 132700 and 132676, sent by Messrs. Patek, Philippe & Co., Geneva, which obtained respectively 92.2 and 91.9 marks.

Marine Chronometers.—There has been an unusually large number of marine chronometers submitted for trial during the year, the entries having risen to 174. Of these 134 received certificates and 40 failed.

ABSTRACT OF ANNUAL TRIAL OF CHRONOMETER WATCHES, 1907.

In forming the Trial Number $a + 2b + \frac{1}{3}(c + \frac{d+e}{3})$, the quantities *a, b, c, d, e* are taken numerically, irrespective of sign. The period of rating was for 16 weeks, from 1907, August 3rd, to 1907, November 23rd, and the watches were tested in heat and in four positions, namely, dial up, pendant up, right and left respectively. All the Watches are Keyless.

Order of Merit	Maker's Name.	No.	Difference between greatest and least weekly rates. Dial up. <i>a.</i>	Greatest difference between one week and the next. Dial up. <i>b.</i>	Difference of Weekly Rates.			<i>a + 2b</i>	Trial Number $a + 2b + \frac{1}{3}(c + \frac{d+e}{3})$
					Pendant up, minus Dial up. <i>c.</i>	Pendant right, minus Dial up. <i>d.</i>	Pendant left, minus Dial up. <i>e.</i>		
					<i>s.</i>	<i>s.</i>	<i>s.</i>		
1	H. White and Co. ... (Cheapside)	1784	13.6	3.7	- 4.3	- 31.9	+ 7.1	21.0	29.7
2	Owen and Robinson...	76679	14.3	3.6	+ 13.1	+ 14.0	+ 14.0	21.5	32.8
3	J. Player and Son ...	31385	12.2	6.2	- 9.3	- 9.8	- 11.6	24.6	32.9
4	J. Player and Son ...	30234	12.1	7.3	- 7.6	- 11.7	- 9.6	26.7	34.1
5	Owen and Robinson ...	93433	10.4	5.2	+ 16.7	+ 16.8	+ 16.8	20.8	34.8
6	Halford and Son ...	5181	9.7	3.5	- 21.9	- 3.9	- 43.4	16.7	35.6
7	Brown and Son ...	39700	20.2	4.5	- 9.7	- 15.0	+ 11.2	29.2	33.5
8	J. Player and Son ...	30813	21.1	7.6	- 1.3	- 8.3	- 7.3	36.3	39.6
9	H. White and Co. ... (Cheapside)	1650	9.1	8.8	- 4.9	- 39.4	- 28.4	26.7	40.5
10	Thorneloe ...	1052	23.9	8.5	- 0.1	+ 2.3	- 0.3	40.9	11.1
11	Stanley ...	1668	13.6	8.0	+ 7.6	- 19.2	- 37.4	29.6	42.8
12	Carroll ...	152374	19.6	8.2	+ 9.4	- 3.4	+ 10.4	36.0	43.0
13	J. Hewitt ...	60453	13.6	10.5	- 3.2	+ 24.0	- 16.9	34.6	43.0
14	H. White and Co. ... (Cheapside)	1645	9.9	9.9	- 13.7	- 13.6	- 30.4	29.7	43.9
15	Thorneloe ...	79303	27.2	7.9	+ 1.5	+ 2.2	+ 2.9	43.0	44.7
16	S. Lyon Junr. ...	57494	23.0	10.4	- 1.3	- 3.6	- 1.1	43.8	45.3
17	J. Hewitt ...	58349	11.5	5.3	- 27.8	- 28.1	- 29.3	22.1	45.6
18	Brown and Sons ...	41028	15.7	9.1	+ 7.9	- 27.1	- 25.7	33.9	46.7
19	Story ...	145735	13.7	11.1	- 16.2	- 8.8	- 11.8	35.9	47.3
20	Yeomans ...	82315	24.8	8.0	+ 8.2	+ 7.0	+ 9.1	40.8	47.6
21	Polland ...	51610	25.4	10.6	- 2.5	- 1.6	- 0.7	46.6	48.3
22	Olivant and Botsford	31180	27.2	7.3	+ 1.0	- 25.9	- 22.6	41.8	50.4
23	Usher and Cole ...	30502	12.5	9.4	- 21.6	- 19.1	- 33.1	31.3	50.8
24	Yeomans ...	80984	21.3	8.7	+ 1.7	- 16.6	- 51.1	38.7	50.9
25	J. Hewitt ...	60450	15.1	10.6	+ 19.2	- 13.2	+ 30.7	36.3	53.2
26	J. Player and Son ...	31386	17.5	12.8	+ 9.3	+ 17.3	+ 19.4	43.1	53.9
27	J. Player and Son ...	33937	27.2	8.5	- 7.4	- 17.9	+ 18.8	44.2	54.0
28	J. Player and Son ...	33519	21.3	8.9	- 18.6	- 18.0	- 18.5	39.1	54.5
29	Wright and Craighead	8340	20.9	8.1	- 18.4	- 31.5	- 22.1	37.1	55.2
30	Sims ...	05150	17.4	9.2	+ 27.2	+ 21.3	+ 27.2	35.8	57.5
31	J. Player and Son ...	35241	15.8	8.5	- 14.9	+ 36.5	- 70.1	32.8	58.1
32	Armstrong Bros. ...	149	26.8	10.1	- 12.5	- 15.4	- 13.1	47.0	58.1
33	J. Hewitt ...	60022	22.8	10.9	+ 19.7	+ 28.5	+ 5.1	44.6	60.1
34	Kendal and Dent ...	10606	15.7	14.6	+ 20.8	+ 18.7	+ 25.0	44.9	62.6
35	J. Player and Son ...	33938	11.3	9.7	- 38.7	- 28.2	- 49.7	30.7	63.1
36	H. White and Co. ... (Cheapside)	15653	24.6	11.7	+ 9.8	- 25.2	- 44.6	43.0	64.5
37	Halford and Son ...	5179	22.0	12.7	+ 2.7	- 37.7	- 56.8	47.4	64.6
38	J. Hewitt ...	60023	19.8	11.4	+ 28.6	+ 22.9	- 24.5	42.6	64.8
39	Birch and Gaydon ...	2568	21.7	13.4	- 24.2	- 23.8	- 24.9	48.5	68.7
40	George ...	51341	20.7	9.1	+ 40.0	- 33.7	+ 49.3	38.9	72.7
41	J. Hewitt ...	60452	13.3	9.4	+ 59.1	+ 46.7	- 35.7	32.1	75.4
42	Stanley ...	1667	20.4	11.1	+ 48.6	+ 27.6	+ 25.2	42.6	75.7
43	Usher and Cole ...	30574	19.6	14.5	- 33.8	- 29.7	- 66.3	48.6	81.5

P. H. COWELL (For Astronomer Royal).

For the Year of 1907

The Annual Timing Contest of the
GENEVA ASTRONOMICAL OBSERVATORY

awarded

53 out of 101 Prizes

TO

Patek, Philippe & Co. WATCHES

Namely:—The only First Prize for best Average Running among Makers. 4 First Prizes out of 5 (Including all the highest) for best individual running.

10 Second Prizes	out of 18
9 Third " "	" 17
12 Fourth " "	" 26
7 Honorable Mentions	" 18
10 Single Prizes	" 17

19 MANUFACTURERS PARTICIPATED.

Previous results at these contests

1906—49	out of 85 Prizes, incl. the First and Highest Prizes
1905—46	" 65 " " " " "
1904—36	" 46 " " " " "
1903—42	" 54 " " " " "
1902—32	" 56 " " " " "
1901—28	" 49 " " " " "

Awarded Hors Concours (Beyond Competition)

Milan, 1906.	St. Louis, 1904.	Paris, 1900.	Paris, 1889.
	Antwerp, 1885.	Zurich, 1883.	

Gold Medal

Nuremburg, 1905.	London, 1885.	Calcutta, 1883.
Croningen, 1880.	Paris, 1878.	Vienna, 1873.
Paris, 1855.	London, 1851.	Paris, 1844.

Diploma of Honor: Nice, 1883.

NEW YORK
 68 Nassau Street

GENEVA.
 SWITZERLAND

GUINAND'S RELIABLE SPLIT TIMERS AND SPLIT CHRONOGRAPH WATCHES

In NICKEL, GUN METAL, SILVER
 AND GOLD FILLED CASES



JULES RACINE & CO.

EXCLUSIVE IMPORTERS

Chicago Office: 103 State Street
 New York Office: 37 Maiden Lane

FOR SALE BY ALL JOBBERS

HALL CLOCKS



Elliott's
 Celebrated
 Tubular
 Chimes

HARRIS & HARRINGTON,

12 BARCLAY ST.,
 NEW YORK

Sole Agents to the Trade
 for
 J. J. ELLIOTT & CO.
 LONDON.

WATCH REPAIRING FOR THE TRADE

Careful, Reliable, Prompt Work. Trade Refer-
 ences. Price List on Request.

A. D. PAPAZIEN

71-73 Nassau St., Cockroft Bldg. NEW YORK

A Page from Watch History

The picture at the left shows the old Roman tower in which the **Vacheron & Constantin** watch factory was located in the early days of watch history.



The picture at the right shows the present factory, built in 1875, and remodeled some years ago.

These illustrations not only mark the progress of the **V. & C.** watch, but of the entire watch-making industry, for the **Vacheron & Constantin** was recognized as the standard of excellence when the watch was first placed on the market in 1785, and is so recognized to-day.

It has always led in correct, scientific principles, in absolute accuracy, and in all the various improvements in watch manufacture since the establishment of the house. It has captured many first prizes in international timing contests, and its unquestionable superiority renders it the most salable and profitable high grade watch that the dealer can offer his customers.

The **V. & C.** line embraces every variety of adjusted watches, complicated watches, extra flat, ultra flat, and enameled, carved and jeweled watches.



EDMOND E. ROBERT, Sole Agent, 3 Maiden Lane, New York

The Favorite Movement with both Trade and Public

The Omega Movement

stands in high favor with the trade, and is constantly increasing in popularity for the reason that the public is quick to appreciate its merits.

The man who carries an Omega is proud of it and misses no opportunity to sound its praises to his friends. He finds it invariably and uniformly reliable. He learns to depend upon it and it never abuses his confidence.



Ω
OMEGA

Adaptable, Interchangeable, and Suited to all Requirements

The Omega is made in all sizes to fit regular American cases, besides a number of Swiss sizes. Every part is interchangeable, and all are made with lever escapements, double roller and pendant set. There are six different grades — from seven jewels to twenty-one jewels — adjusted to heat, cold, and five positions.

EDMOND E. ROBERT
3 Maiden Lane New York

WESTERN SELLING AGENCY
Omega Watches
Heyworth Building, Chicago

CROSS & BEGUELIN
31 Maiden Lane New York

Ball Watches
THE RAILROAD STANDARD

Mr. Retailer!

*Every Time You
Sell a "Ball" Watch.*

1. You earn a fair return on your time and capital invested.
2. You secure a satisfied customer (the best advertisement of all).
3. A machine goes into service which will add to your reputation as a reliable "watch man."

Write to-day **THE WEBB C. BALL WATCH CO.**

Ball Building, CLEVELAND Railway Exchange, CHICAGO



WM. C. PENFOLD CO.

No. 35 MAIDEN LANE, NEW YORK

LARGEST EXCLUSIVE WATCH JOBBERS IN NEW YORK OF

Dueber-Hampden Watches Dueber Cases — Hampden Movements

A Complete Line Always on Hand. Mail Us Your Orders

A.W.C.CO

Moderate-priced Cases



14K.

C-1992

The illustration represents one of a large line of gold cases designed to sell at prices in accord with the expectations of the average purchaser. It isn't cheap, neither is it expensive; but nicely adjusted to the circumstances of the every-day buyer. The price and quality are rather disproportionate. We invite comparison to emphasize the superiority of these cases.

Sold by us directly to you

American Watch Case Co.

9-11-13 Maiden Lane

New York

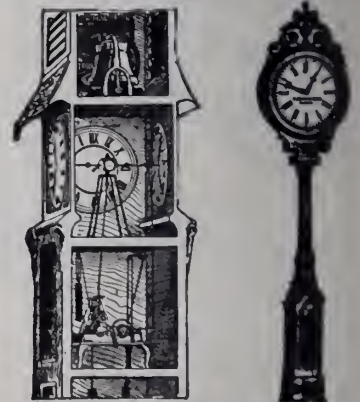

MAKERS OF

Tower and Street Clocks

For particulars write us, mentioning The Jewelers' Circular-Weekly.

E. HOWARD CLOCK CO.,

EST. 1842. BOSTON, MASS., U. S. A.

The wise jeweler will see to it that his stock of

New England Watches

never grows low.

A full line of the *New England* is an essential part of every up-to-date stock these times.

The New England Watch Co.
WATERBURY, CONN.

Chicago

San Francisco

Buy Watches With Our Patent Ball-Bearing Bow

Already on the Market

No watch case should be without it.

BEWARE OF IMITATION

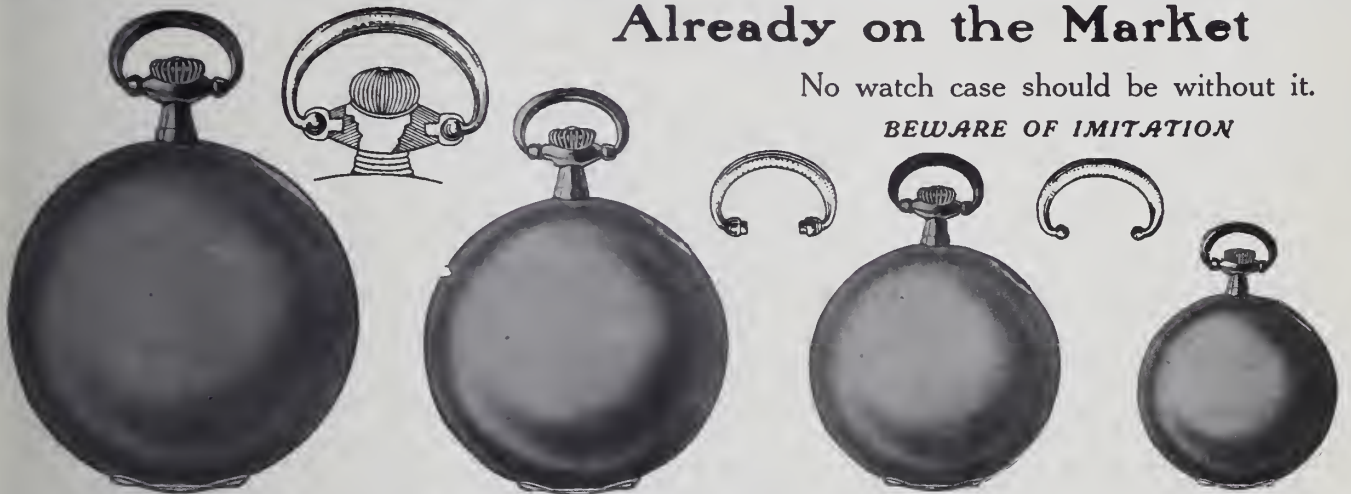

Should your jobber not sell cases with these bows, write us and we will give you a list of jobbers who do.
Patented July 25, 1905; May 21, 1907. Other patents applied for.
Patented in foreign countries.

The Wachter Manufacturing Co.
HARTFORD, CONNECTICUT

HOROLOGICAL DEPARTMENT
BRADLEY POLYTECHNIC INSTITUTE
Formerly Parsons Horological Institute
PEORIA, ILLINOIS
LARGEST AND BEST WATCH SCHOOL IN AMERICA
We teach Watch Work, Jewelry, Engraving,
Clock Work, Optics. Tuition reasonable. Board
and rooms near school at moderate rates.
Send for Catalog of Information

JULES JÜRGENSEN
Watches and Chronometers
PARIS—"THE GRAND PRIX"—1900

SOLE
RUDOLPH & SNEDEKER
65 Nassau St., New York
AGENTS

STORE KEEPING DEPARTMENT

That this department shall prove mutually beneficial to our readers, it is desirable that the members of the trade generally communicate with THE JEWELERS' CIRCULAR-WEEKLY regarding any advantageous device or plan which they are utilizing in connection with their business.

THE JEWELER'S APPEAL TO THE FARMER.

Written expressly for THE JEWELERS' CIRCULAR-WEEKLY by FRANK FARRINGTON.
(Continued from issue of March 4.)

THE children of any parents ought to have careful attention, but this is particularly true of the farmer's children. These youngsters are shy and hate to go into a store and ask for things unless they are perfectly certain they are right. When they come into your store see that they are made to feel at home. Their purchases will probably amount to very little. They may seem scarcely to be worth bothering with and yet if you are in business to stay you will be surprised (unless you have already noticed it), to see how soon those same small children will be big enough to be coming for purchases that do amount to something. They grow up very quickly. The difference between childhood and the point where they shop for themselves is a very few years.

More than that, every child who visits stores, goes home and tells how he was treated. That stamps the character of the store upon the mind of the people at home, for a store can be judged by the way it treats children and in every family the children are so important a part that to treat them badly is to make enemies of the adults there.

In advertising to the farmers it is important to look after the reasonable demands of the class. There are in the farmer's case more articles of reasonable use than in the case of most people. The farmer's business is a business of seasons. His work is one thing to-day and another a week from to-day. His different occupations call for different articles of utility and though such articles are not often within the range of the jeweler, there is necessarily a difference in his needs this season and next season, summer, fall, haying, harvesting, planting, etc.

The goods which the farmer will buy at any time are rather different from those of the townspeople and the advertising aimed at the outside buyers should be especially prepared, but without any intimation that they are different or in any way odd. Many of the farming class are still a little sensitive upon being called "farmers." The comic press is largely responsible for this condition.

Newspaper advertising that is directed at the farmers ought not often to specify that

fact. Farmers should be made interested simply by calling attention to goods in which they will be interested.

Direct advertising can be done well in the form of imitation typewritten letters with the names filled in. A lineograph or some such machine can be secured for \$18 or \$20 that will do such work well enough and it can be used in a hundred ways as a business getter. It will make package slips and even dodgers. It is a good investment at the price.

The form letter to the farmer will appeal to him as personal if it has his own name filled in at the top and a bona fide signature at the bottom. A good rubber stamp will make signatures rapidly that cannot at a glance be told from the genuine by an inexperienced person.

Such advertising makes the farmer interested in you personally. He feels a personal interest in the store and the general effect in addition to the sales producing effect is valuable.

Advertising for the farmers should describe the goods fully and always give prices. Get the mail order house catalogue and see what they offer in the way of the goods that you are about to advertise. The farmer who reads your advertisement will more than likely have that catalogue in his house and it is more than possible that he will if interested in the goods compare your offer with that of the catalogue house.

If the farmer has been contemplating the purchase of the goods you advertise, you may depend upon it that he knows what he can buy those goods for elsewhere. He does not buy your kind of goods off-hand. He thinks it over and often the purchase of a watch or a set of teaspoons is a thing which the family has been planning for a year or so. It would be folly to send this man an ad saying, "We sell all kinds of silver teaspoons" and expect that bare statement to catch him when he has another ad that pictures the spoons, tells what make they are and the price, and gives a good broad guarantee with them.

Be specific in all advertising and especially so in the advertising that is meant to appeal to the farmers.

It is not difficult to secure a good mailing

list of the farmers in your vicinity, but it is most important. A list kept corrected up to date is the basis of all your direct advertising.

The post office officials have no right to give a list of their patrons though they do have the right to correct an already made-up list. The R. F. D. names can be secured by driving over the routes as the names are on the farmers' boxes but of course this will not secure the names that are not on those routes.

Getting a List of Names.

One way of getting the names is from the tax rolls. Another way is to buy newspaper lists or to hire someone to travel over the roads and secure names.

As farmers are easily interested in schemes of various kinds, it is possible to get a good list of names by offering prizes for contributions to simple prize schemes with long lists of prizes so that everyone will feel that there is a great big chance of getting something out of it.

No one plan will get all the names. It is wise to try them all and keep adding to the list as the names come. Give out souvenirs in the store to the farmers, asking them to register their names in return. Ask the farmers you know to give you the name of their neighbors. There are plenty of ways of getting names and in the end you will have a list which will comprise all the best names.

Dealers in other lines of goods may have lists already prepared that they will sell on loan and in some towns the merchants' associations prepare for their members just such lists as you want.

The farmer after all is a man not substantially different from others and requires much the same treatment. He is a business man more than ever before and does business on a cash basis where it used to be long time accounts payable in produce or when the produce was sold.

When you think of the farmer, put yourself in his place and you will have no difficulty in devising ways of treating him to gain his confidence and his friendship. Do not patronize him or look down upon him. He is a better man than you are in many ways. He knows his business as well as you do yours and in proportion may be even more successful at it. He is no longer narrow-minded, if the man who spends his life in the open could ever have been really so. He is a good man to do business with and it is decidedly worth while to try for his money.

[THE END.]

Storekeeping Department.

An Attractive Jewelry Emporium Down in Old Mexico.

DOWN in the city of Mexico, A. C. Smith bears the distinction of having opened the first real American jewelry store. It is unlike any other in that country, and stands unique. It is patterned after the newer stores on upper Fifth Ave., New York, and few stores of its size in New York or elsewhere can compare with it in elegance of appointments.

The floor is white and black mosaic. The ceiling, which is 20 feet high, is steamboat white, with a cove of stucco in bas relief in Italian Renaissance, tinted in old ivory running around the entire room. Below this is a band of dark green, two feet wide, terminating in a light band of gold. The walls

plate glass case, fitted with glass shelves and having a door at each end leading to a handsomely fitted up diamond parlor. This rear case has plate glass on both sides and is filled with choice pieces of sparkling cut glass. The four other wall cases are used for the display of sterling silver. All these cases are lighted from the top by invisible lights which, when turned on, produce a dazzling effect.

The display cases are of rosewood mouldings and plate glass and rest on mahogany tables—two 10 feet long and one eight feet at the front and with rounded end joining at a right angle to the others. In these cases is displayed a gorgeous array of diamonds, watches and rich jewelry.

The window arrangement is of itself novel and consists of a high dark mahogany case in each window, draped in white silk, in which are displayed a few rich and choice pieces. These cases are lighted from the

D. E. Thompson, British Minister Reginald Tower, Japanese Minister Baron Arakawa, Governor of the Federal District Guillermo de Landa y Escandon, E. N. Brown, president of the National Railways.

Timely Suggestions to Advertisers.

PEOPLE in agricultural districts which are full of money on account of the high prices the farmers are getting for their products will find advertising of the following goods in papers that reach the rural communities remunerative:

Pianos, pianolas, organs, phonographs, music boxes. Farmers in their quiet homes, enjoy music.

Clocks, watches, jewelry, furniture, books, especially historical works, lamps, kodaks, silverware, rifles, sewing machines, fountain pens, birds.

In addition the ruralists will be able to



INTERIOR AND EXTERIOR OF THE RETAIL JEWELRY STORE OF A. C. SMITH IN THE CITY OF MEXICO.

are in dark green burlap. On each side are two large shallow alcoves 17 feet square, supported by three square black marble columns with Corinthian Capitals in old ivory.

At the rear are two large arched windows, with the arches and capitals in old ivory and black marble columns. The front is distinctively new to Mexico and one of the handsomest to be found anywhere. It is done entirely in Royal Danish marble. The entire upper wall as well as the front wall, inside window casing and window ceilings are in large slabs of dark green marble with black marble wainscoting. The doors are double, made of dark mahogany with long narrow beveled edge plate glass. On either side of the doors is a large round column of dark green marble resting on square marble bases. The entire effect is extremely handsome and pleasing.

The furniture and fixtures are of solid dark Santo Domingo mahogany of dull finish. There are two 12-foot mahogany and plate glass wall cases on each side of the store, connected with four-foot mirrors and with black leather covered settee and mirrors set in mahogany panels joining at the front end of the store. At the rear is a cross partition with a 10-foot mahogany and

top by invisible electric lights, presenting a beautiful picture set in a dark frame.

The color scheme of the store is green, gold and ivory with rich dark dull mahogany fixtures, which for artistic taste and elegance in richness surpasses anything to be seen this side of the Rio Grande, and reflects deserved credit on Mr. Smith and his able assistant, Mr. Kinehan, who have been untiring in their efforts to make this the handsomest store in Mexico.

This store is the result of public demand and was made possible through a rapidly increasing retail business. It is under the management of Mr. Kinehan, who has been Mr. Smith's trusted lieutenant for several years and who has by his genial manners and close attention to the interests of customers won for himself their respect and confidence. This store does a strictly retail business separate and additional to Mr. Smith's present railway watch inspection and wholesale business in Cinco de Mayo.

The location is one of the very best in the city, on the main thoroughfare, right in the heart of the retail district and banking center.

Among the distinguished people who visited the store during the formal opening were the following: American Ambassador

buy more of the necessities of life and of farm implements than ever before.

The greatest wealth producers of 1907 will be the best buyers in 1908.—*Mail Order Journal*.

The Labor Market Cornered.

SAN MARCOS, Tex., Feb. 19, 1908.
Editor THE JEWELERS' CIRCULAR—WEEKLY:

Herewith I present to you a literal copy of the printed billhead or letter head of one of the craft in Texas, barring, of course, the name of town and the genius who presides over this wonderful shop. How can you match that? Bring on your man and his billhead.

Yours sincerely,
GEO. H. KNIGHT.

—, Texas, —, 190—.

S. V. SABLEGROVE,
BLACKSMITH AND WHEELWRIGHT,
Silversmith, Jewelry Repairer, Gunsmith, Sewing Machine Repairer, Bicycle Repairer, Lock Repairer, Umbrella Repairer, Trunk Repairer, Furniture Repairer, Organ Repairer, Stove Repairer, Plumber, Painter, Well Digger, Cistern Plasterer, Brickmason, Hotel Cook, Waiter and Experienced Horse Doctor.

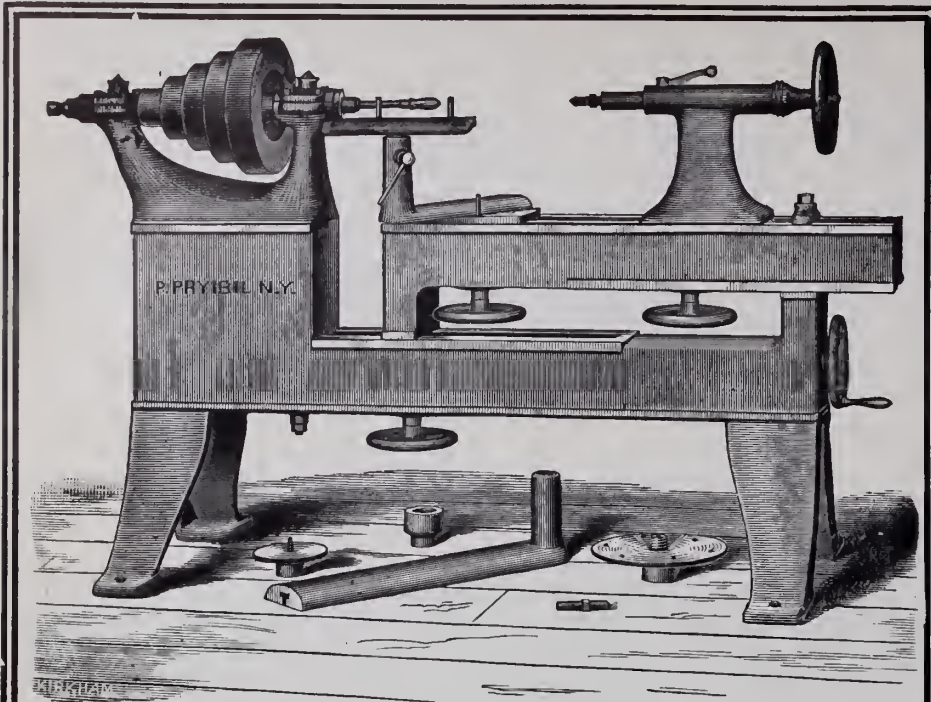

Above Cut Shows Our
EXTENSION SPINNING LATHE.

Swing of lathe 22 inches when closed, 44 inches when extended.
Substantially built for heavy work.

Write for
Catalogue

P. PRYIBIL, 512-524 W. 41st St., New York.

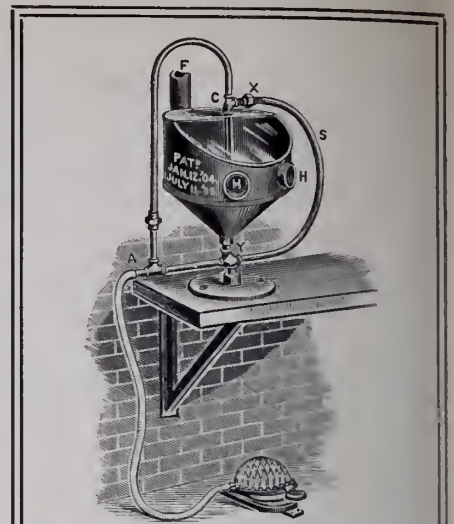

**A Small Compound
Sand Blast**

Price, \$20.00 Foot Bellows, \$6.00

WORKS AS EFFECTIVELY WITH
FOOT BELLOWS AS WITH
POWER BLOWER :: :: ::

MADE of Galvanized Sheet Iron, 10 inches diameter, Glass Top, Fittings of Brass and Iron, practically indestructible. Satisfaction guaranteed. Ask your Jobber for it, or write to us. Other Specialties: Zeuner's Best Jewelers' Saws; American Swiss Files, equal to the best imported; Gas Furnaces, for Melting, Annealing, etc., etc.; Positive Pressure Blowers.

E. P. REICHELME & CO.
JEWELERS' TOOLS, FILES AND SUPPLIES
24 JOHN STREET, NEW YORK

1 2 3 4 5 6 7 8 9 0 1 9 0 8 A B C D E F G H I J K

Alphabet and Figures

FOR CLASS RINGS, EMBLEMS, ETC..

HERPERS BROTHERS,

SETTING MANUFACTURERS,

Newark, N. J.,

1 9 0 8

1 9 0 8 A B C D E F G H ETC. 1 9 0 8

Importer and Manufacturer of
WATCH MATERIALS, TOOLS, JEWELERS'
SUPPLIES AND OPTICAL GOODS

Bargains
in
**Staking
Tools**

Prices on
Application

Fine Gold, Silver and Platinum always on hand.
Highest Prices paid for Old Gold and Silver.

A. ZAREMBOWITZ
250 East Houston Street NEW YORK



HERMAN KOHLBUSCH, Sr.,
ESTABLISHED 1859.
Manufacturer of Fine Balances and Weights
for every purpose where accuracy is required.
Office and Salesroom, 194 BROADWAY, NEW YORK.
Send for Price List. Tel. 370 Cortlandt.



PLATINUM AMERICAN PLATINUM WORKS
NEW YORK OFFICE
41 Cortlandt Street
NEWARK, N. J.



WORKSHOP NOTES AND QUERIES

[Answers are also solicited from our readers to the questions published on this page.]

QUESTION No. 2086.—Stripping Gold.—*I would like to know a little more about stripping gold by zinc battery as per your answer to question No. 2069. We took two wet batteries and refilled them with new sal ammoniac and new zinc, connected the positive pole or carbon end of battery and placed our rings on the hook connected with zinc. Then we put two ounces of cyanide of potassium and one quart of water in porcelain dish. When the ring was dipped in the boiling solution there was an action around the ring which did not affect it any. It seemed to leave a rust-like deposit on the ring. We wish to use this for taking the Roman finish off signet rings. Can you see where our trouble is?* E. J. A.

ANSWER:—If you will read answer to question No. 2069 again you will see that you must connect the ring with a wire from the negative pole and make connection with the solution by putting a piece of sheet iron, or a nail, on the positive pole, which will do the work if the battery is right. Stripping an article is accomplished in the same way as depositing, excepting that the cathode and anode are reversed; using the piece to be stripped as an anode, takes off the metal or strips it.

QUESTION No. 2087.—To Remove Gray Finish.—*Will you please let me know how to take oxidizing, a gray finish, from a case so that it can be resilvered?* G. S. & Co.

ANSWER:—Oxidizing or gray finish can be removed by placing the article in a strong cyanide of potassium dip. If this does not remove it heat the cyanide dip and the oxidizing will be removed. Then proceed to clean and resilver in the usual way. If the article was well silver-plated originally, then it can be burnished and polished without replating. A strong cyanide dip is composed of one pound of cyanide of potassium to each one gallon of water.

QUESTION No. 2088.—Engraved Combs.—*We have some demand for engraved combs. We refer to a plain back comb engraved with monogram and the cuts filled with gold (?). We have been using just plain gilding, but it comes out. What kind of gold paint or other substance could we use?* J. H. B. Co.

ANSWER:—For the filling of monograms on celluloid combs the bronze powder, made into a paint, may be used. These powders can be purchased in all colors, and a gold-colored bronze powder would answer the purpose. The paint is made by mixing the powder with a pale varnish and painting the engraving in with a fine brush. When dry any surplus that has run beyond the letters

can be wiped off with a cloth saturated with alcohol. As combs are made out of different materials, a prepared gold paint may be very adhesive for one material and it may not hold on another. Therefore it is best to try a little first and find what is best suited for the material. The pale varnish is considered good adhesive for most materials, while for some alcohol and bronze mixture is suitable. Another good one is the liquid glue, mixed with the bronze; first thin the glue with a little warm water. Celluloid and horn combs cannot be heated much without spoiling them, but warm them as much as they will stand and the paint will hold better.

QUESTION No. 2089.—Scraping Sound in a Watch.—*What causes the scraping sound in a watch when held to the ear in a certain position and when all the balance jewels and the staff are, or seem to be, all right?*

ANSWER:—A loud scraping sound in a watch may be caused by the rim of the balance coming in contact with something, which may be the center wheel, the hair-spring, stud or the regulator pins. A scraping sound can hardly be in the escapement.

QUESTION No. 2090.—Ring Casting from Old Gold.—*In making old gold into rings I made one in which the gold worked easily and was not brittle. This ring was cast in charcoal. Having some gold left from this ring, but not quite enough, I added to it the bezel of an old Brooklyn ("U. S. Assay") case. The filings from the first ring were not put into the second. In melting it borax and saltpeter were used, and it was cast in an asbestos mould. This casting was brittle and broke when hammered. After remelting and recasting I filed and smoothed it up before hammering, but still it was brittle. I annealed it often enough, so I think that could hardly be the fault, for it was very hard immediately after annealing, as before. I am unable to determine why the gold became hard and brittle. I would like to know how to make it soft and more workable.* L. J. K.

ANSWER:—One of the most difficult tasks for the working jeweler is to turn scrap to good account. It may be considered an unusual success when a ring is cast in a malleable condition. The alloying of gold is a great science, and the purifying of old gold is the same. When you added more gold to the original quantity, the presence of the part of a grain of lead or soft solder would cause as much as an ounce of gold to be ruined for use. There are other metals which would produce a similar effect. Pure silver and pure copper are the only metals suitable for the alloying of pure gold; and such gold is generally a

metal which gives no trouble in working up into jewelry.

A Novel Method of Utilizing Silver Scrap.

From the Brass World.

IN close-plating with silver, a thin silver sheet is soldered to a base metal, and smoothed down so that to the ordinary observer the article has the appearance either of solid silver or of one heavily electroplated. The silver, known as "close-platers' metal," is cut into the shapes that are necessary for covering the article and so as to form as good a joint with each other as it is possible to make them. There is, therefore, considerable waste in the form of clippings and trimmings.

It is usually customary in the close-plating trade to sell this scrap back to the mill from which the sheet was obtained; but one enterprising close-plater, who also carries on electroplating, has devised a method of utilizing it that allows the full value of the silver to be obtained. Close-platers' silver is always pure and contains no alloy

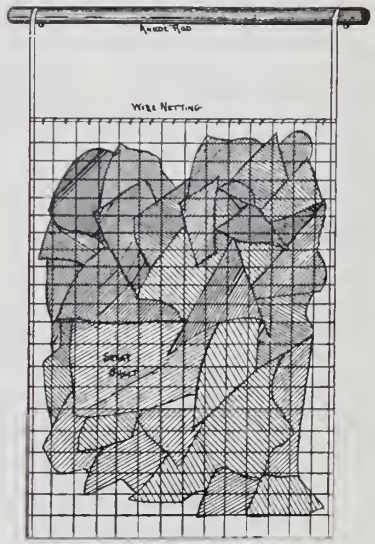

METHOD OF USING SILVER SCRAP AS ANODE.

at all. He uses the scrap as anodes in silver plating and obtains good results.

The novelty of the method lies in the manner of holding the scrap. The sketch herewith shown will serve to illustrate it. Two pieces of iron wire netting are placed together in the shape of a gridiron and the scrap is held between them. Two heavy wires are fastened to the sides and act as hooks for the anode rod. The wire must be free from any coating and, therefore, galvanized wire will not answer. The bare iron must be used.

Cyanide solutions do not act upon iron so that nothing but the silver is dissolved. The constant immersion of the iron under the solution serves to keep it from rusting. Close-platers' silver is quite pure and leaves practically no deposit upon the surface as it dissolves so that the scrap dissolves evenly and completely without requiring any attention.

William Sader, New London, Wis., has been installing a small engine designed to create power for a couple of lathes and for a mechanical display in his store.

C. DORFLINGER & SONS

36 MURRAY STREET

NEW YORK

Hand-Made Blanks only.
Cut, engraved and etched
glass. Light, medium
and heavy stemware,
tumblers, etc.



The Pairpoint Corporation

NEW BEDFORD, MASS.

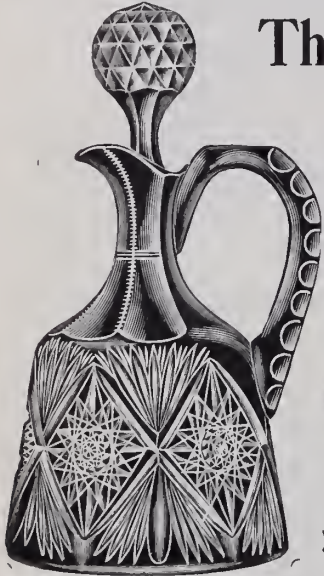

SUPERIOR
SILVER PLATED
WARE

RICH
CUT GLASS
WARE

ELECTROLIERS
GAS PORTABLES, ETC.



No. 4935.—Smoking Set.
BRANCHES

No. 692.
Whiskey Jug.
"Uncatena."

38 Murray Street - - - - NEW YORK CITY
717 Market Street - SAN FRANCISCO, CAL.
485 St. Catherine Street - MONTREAL, P. Q.



Manufacturers' Distributor
35 MAIDEN LANE

"La Vigne"

NEWEST and Best-seller in
ROGERS SILVER-PLATE

Bright
or
French-Gray-Finish



TEN CENTS in postage will
bring you sample teaspoon.

JOSEPH IRONS, 35 Maiden Lane
NEW YORK, N. Y.

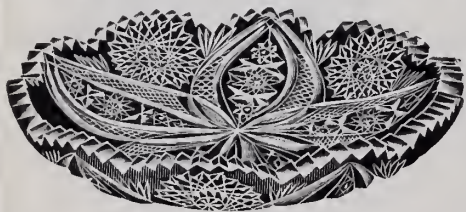

7-in. Saucer, Pansy No. 205

KELLY & STEINMAN, Inc.

Manufacturers of

Rich Cut Glassware

Is Quality any consideration
with you? If so, let us send
you a Sample Order.

OUR PRICES ARE MODERATE

KELLY & STEINMAN, Inc., HONSDALE PENNSYLVANIA

Irving Cut Glass Co. Inc.

Manufacturers of

Artistic Cut Glass

HONSDALE, PA.

F. W. REICHENBACHER

New York Representative

No. 25 WEST BROADWAY, Room 43



"Wild Rose," No. 122—14-inch
Ice Cream Tray

The St. James

Cor. Walnut and 13th Sts., Phila., Pa.

THE IDEAL HOTEL OF
THE QUAKER CITY

A spacious fire and burglar proof
safe has been provided for the con-
venience of the trade. Palatial
rooms with bath \$2.50 per day
and up. Rooms without bath,
(running water) \$2.00 and up.

EUGENE G. MILLER, Mgr.

JACOT MUSIC BOX CO.

MIRA MUSIC BOXES
AND MIRAPHONES

39 UNION SQUARE - NEW YORK.

Established 1879

Manufacturer of

LOUIS W. HRABA Fine Leather Goods

29 East 19th St., New York

Exclusively for the Jewelry Trade

THE CONNOISSEUR



Devoted to Art Pottery, China, Marbles, Bronzes, Cut and Decorated Glass Ware, Bric-à-Brac, Lamps, Art Metal Wares, Fancy Goods and Kindred Lines.

MEXICAN POTTERY MANUFACTURE.

Antiquity of the Industry—Production of the Cuernavaca Ware.

THE pottery industry of Mexico, writes Special Agent Arthur B. Butman, is of ancient origin, having been handed down from father to son from time immemorial. Excavations among the prehistoric ruins of Mitla have resulted in the unearthing of many specimens of this handicraft, the designs of which are reproduced to this day. A description of the industry is appended: Cuernavaca, Guadalajara, Puebla and Oaxaca are the principal centers of the modern pottery industry, although pottery is manufactured in many of the smaller towns and villages throughout the republic. The pottery manufactured in these cities possesses distinctive types and characteristics, each quite different from the others, and universally known and recognized by the name of the city where it is made.

Cuernavaca pottery is manufactured in the little village of San Antone, just outside the city of that name. The dwellers in practically every one of the adobe houses in the village are clay workers, and each house is a workshop. The only established plant is here made entirely by hand, and after the following process:

PREPARING AND MOLDING THE CLAY.

The clay, after being taken from the earth, is first thoroughly dried in the sun, then pulverized with a wooden mallet and passed through the finest meshed brass-wire cloth, after which process the clay is finer than wheat flour. The former custom of the Indian was to use a handkerchief or a piece of cotton shirting for this purpose. For mixing, a fine slime is prepared by soaking a portion of the pulverized clay in water, passing it through a sieve, and afterwards mixing the dry clay and kneading to the right consistency.

A mold of the required size for the body of the article to be made is placed on the upper portion of the old style potter's wheel, covered with the proper thickness of clay, then patted and shaped with a wooden paddle and with the hands. The Indian potter turns the model about before him by scraping his bare toes on the lower portion of the wheel, and during the revolutions he continues to smooth the clay with a narrow strip of wet cloth until the desired surface is obtained. The narrow standard or legs, as the case may be, are then fashioned, and the article removed from the mold and placed in the same inverted position until such time as the standard shall have dried sufficiently to hold the weight of the body.

Handles, spouts, etc., are all formed by the hands, without molds, and joined by means of the clay slime and prepared clay.

DECORATING AND DRYING PROCESSES.

One characteristic peculiar to the Cuernavaca pottery is the inlaid decoration, for which small bits of broken china are employed. Other decorations principally used are molded reptiles and insects, molded leaves and flowers, and stamped work (Grecian and conventionalized border designs).

The making of the inlaid work is a slow and primitive process, and the execution of the many and often elaborate effects thus wrought is a great tribute to the artistic and patient Indian potter. The design to be used is first drawn upon thin paper, then placed on the damp clay and traced with a small sharp-pointed stick, after which it is slowly wrought by pressing bits of china of the proper shape into the clay, with the glazed surface on the outside. The article is now thoroughly smoothed with a wet cloth and placed in the drying room.

Molds for the formation of decorations are made in plaster of Paris from the live reptiles, insects, etc., so that each is perfect in detail. These decorations are formed by carefully pressing the clay into the mold and as carefully removing it. The edges are then trimmed and the molded decoration placed in the desired position on the article to be decorated, using the clay slime as a cement. In cutting portions of the clay preparatory to molding a crude tin knife is employed. For trimming edges a thread of fiber is used, one end being held in the mouth, the other in the hand. Stamps for fashioning the stamped decorations are made from hard wood, hand carved by the Indian.

During the drying process the pottery is watchfully shielded from sun and wind and a careful examination made each day of every piece in the drying room, so that, if possible, the molded decorations may be prevented from cracking. Should these crack before the articles are completely dried it is possible to replace the decoration, otherwise the article is valueless. While drying the handles and other delicate portions are wrapped in cloth, that the process may be equalized. At a certain time the molded decorations are well scraped and cleaned, and when thoroughly dry the pottery is polished with a piece of rough sacking and finally with a smooth cloth. It is now placed in the sun, to be completely heated before painting and burning. One

color only is used in the painting of Cuernavaca pottery. This is a yellow clay from the neighboring mountains, similar to yellow ochre, simply mixed with water. The pottery is now ready for burning.

METHODS OF BURNING.

Here again we find a method most primitive. I was informed by the proprietor of the pottery factory that the habits of these Indian potters, together with a natural antipathy toward progressive usages, almost prohibits the introduction of new tools or methods. In fact, the workers refuse to substitute certain small modern tools purchased for the work, preferring their own crude ones.

No permanent kiln is used for burning, each individual process being accompanied by a building of a kiln of the size required in the following manner: A number of jars, approximately 18 inches in height and nine inches in diameter, are placed on an open space of ground, as closely together as possible, between and around the outer edges of which is laid the fuel. Flat pieces of previously burned pottery are used to cover the jars and fuel upon which are piled the articles to be burned. The whole is then completely covered with many "comales" (round, flat slabs, which are used for cooking the "tortillas," a sort of a pancake and universal peon food, by being placed over burning charcoal). The fuel is then set on fire, and when well alight green grass or wet hay is thrown over the pile. The necessary burning occupies about two hours, after which time and while red hot the kiln is uncovered. Each article is removed, being lifted by an iron rod, and allowed to cool in the air, which concludes the process of manufacture.

After burning the painted portions of the pottery will have turned to a dark terracotta, and the unpainted portions, or such pieces as are wholly left in the natural color of the clay, will have changed from a dark gray to a light terracotta color.

The principal loss to the manufacturer occurs during the drying process, almost no breakage resulting from the burning. The Cuernavaca potter will mold any design if a drawing with required dimensions is furnished him.

The Mexican Government recently ordered a Cuernavaca vase 32 inches high, with inlaid decorations of the American and Mexican flags and the American and Mexican eagles, as a gift to President Roosevelt.

The form of the lizard, so frequently employed in decorations of this particular pottery, owes its use to the existence of a lizard, nearly nine feet long, carved on a rock, supposedly by the Aztecs, in the village of San Antone.

The wage of the potters ranges from 37



Winter Sports

RICH BROWN GLAZE

is the latest production of the *Royal Doulton* factories. Exquisitely enameled in rich colors.

Sole Agent

W. S. Pitcairn

44 Murray Street
New York

"WINTER"
SERIES No. D2865

Write for Booklet, "Quaint Bits of Royal Doulton"

LEATHER WATCH BRACELETS



Send for assortment on Display Card

ESTABLISHED
1850

C. F. RUMPP & SONS

TRADE  MARK

Manufacturers of FANCY LEATHER WARE

PHILADELPHIA

New York Salesrooms, 683 and 685 Broadway



THE  OIL
NEVER
GOES
WRONG

The trade from ocean to ocean is praising this wonderful oil. IT POSITIVELY WILL NOT GUM.

Can you say as much for the oil you are using? Send 25c. to your jobber for a bottle, and end your oil troubles.

RANLETT & LOWELL CO.

SOLE MANUFACTURERS

Jewelers' Building BOSTON, MASS

Wholesale Selling Agents

M. SICKLES & SONS	Philadelphia
SWARTCHILD & CO.	Chicago
NORDMAN BROTHERS CO.,	San Francisco
D. C. PERCIVAL & CO.	Boston
CHAS. MAY & SON	Boston
DANIEL PRATT'S SON	53 Franklin Street, Boston
SUSSELD, LORSCH & CO.,	New York City
H. S. MEISKEY CO.	Lancaster, Pa.

THE WASHBURN

SECURITY **MAGIC NUT**
Automatic Holder for ear studs, scarf-pins etc.
for all sizes of scarf-pin wire. Guaranteed.



EAR WIRES
for unpierced ears.



SAFETY CATCH
For Brooches, etc.
Can be applied to any work where pin tongues are used.



Open. Closed. Open. Closed.
Descriptive Circular on Application.
Pearl Drilling and Adjusting a specialty.
Special Order Work and Repairing.

C. IRVING WASHBURN, 12-16 John St., N. Y.

PRACTICAL COURSE IN ADJUSTING.
All Jobbers or Jewelers' Circular Publishing Co.
Published Price, \$2.50.
Special Reduced Price, \$1.50, Postpaid.

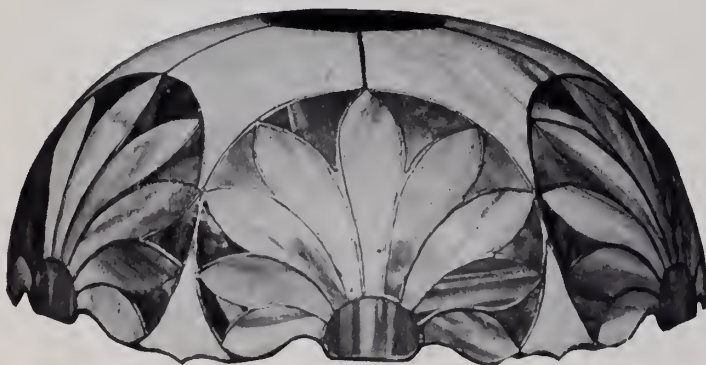

3024 18 in. Diameter TOP HANGER

Unique Art Glass & Metal Co.

46 Park Place, NEW YORK

Makers of High Grade

ART GLASS DINING ROOM FIXTURES

Lamp Shades, Electric Shades
and Portables

CALL IN AND SEE OUR BEAUTIFUL LINE
OF PRODUCTS AT POPULAR PRICES :: ::

Also an elegant line of Rich Crystal Cut Glass
at Factory Prices

centavos to one peso a day, the foreman of the factory receiving eight pesos a week (110 centavos = 1 peso; 1 peso = 49.8 cents)

THE GUADALAJARA POTTERY.

Pottery made in Guadalajara is probably more widely known than that of any other Mexican manufacture. The potteries are situated about six miles from the city proper, in the Indian village of San Pedro. Here another race of potters, true descendants of the Aztecs, live, handing down from one generation to another the knowledge of working this peculiar class of ware called by them "Zapotecas." Many of the original forms and designs mentioned in the records of the friars at the time of the conquest are preserved in the Guadalajara pottery of to-day, this being especially true of the ware known as the "Aromatic" pottery, which is colored in the burning.

The clays from which the Guadalajara potteries are formed are of two kinds, black and white. The black clay is found in veins one to two meters (meter = 3.28 feet) below the general level of the ground, and is a formation of vegetable origin, as is proved by its peculiar odor and also by petrified remains. The veins vary greatly in length, but the width is usually from three to four meters. The white clay is more abundant than the black, and is very compact and heavy, being a subsoil formation, covering large areas and varying from one-half to 2½ meters in depth. It is a great detriment to agricultural interests in the region.

The black clay is prepared by simply dissolving in water, producing a very sticky substance. The white sort is thoroughly dried, pulverized, and passed through a fine wire sieve, then added to the wet black clay and well kneaded. For molding the finer forms the potter uses the substance as thus prepared. If flower pots, garden jars, etc., are desired, a fine sand is added.

Each family of workers are specialists in their line of work. Many forms and designs are produced, but only one design in one family. The potter who molds flower pots cannot mold water bottles, nor can the one who molds water bottles mold figures.

I was informed by the proprietor of the important Guadalajara establishment that the transfer of work has been tried, but always without success. The worker teaches his son to perform the same task as his own, and should he have no son the knowledge of the special form or design of his work is lost at his death. By way of illustration, I was told of an aged Indian who had for many years furnished the firm with a special form of jar, known as the "Montezuma." The Indian died, leaving no heirs, and the loss of this particular article, which was naturally a rarity commanding a good price, resulted.

Unlike the Cuernavaca potters, the Guadalajara workers never use a potter's wheel. Here the small articles are made in molds and the larger pieces are formed by placing a mass of prepared clay on the ground, while the potter walks around and around the clay to be molded, using a piece of hog-skin, well soaked in water, for forming and smoothing the article.

The tools which are employed are a piece of knife of tin, a wire for cutting or trim-

ming, and a nail or small piece of pointed wood never exceeding six inches in length. A dish of water and some white clay in powdered form are placed near by for cleaning the clay from the hands during the process of molding.

The Guadalajara ware is fired or burned in cylindrical ovens, with a hearth and no chimney, made especially for this purpose, different fuels being employed to produce the different colors. For the red-colored pottery a grass locally known as "tepopote" is used, which is found in abundance on lands having a volcanic formation in appearance much like pumice stone. Such lands are called by the natives "jal," and from their formation it is said the State takes its name of Jalisco.

When a grayish-white color is desired, the pottery is burned with twigs of "taray" (tamarisk), or shavings may be used. It is impossible to employ wood or coal of any kind, as the necessary requirement is the flame rather than the heat. The burning process occupies about 12 hours, more or less, according to the size of the oven in use.

The colors employed are mineral, manganese for the black, kaolin for the white, while the reds and yellows are of special kinds of clay. Water bottles, for instance, which are often made in red or yellow colorings, are first painted and then burned, painted while still warm, and again subjected to the flames of dried grass, which burns with much smoke.

The bright greens, blues, etc., are obtained from pigments mixed with gum, varnish, or oils, and, not being fired, these colors will in time wear off. Those interested in the manufacture of Guadalajara ware endeavor to have preserved the old forms, strictly Indian, rather than attempt to produce copies or imitations of forms more modern.

However the ancestry of the primitive Mexican Indian may be decided, it is certain, that the decorations or paintings, which are all of Indian origin, on Guadalajara pottery very closely resemble Chinese decorations.

The wages paid here are approximately the same as in Cuernavaca, the most expert potter receiving not more than one peso a day, and working from 8 A. M. to 12 M. and from 2 to 6 P. M.

PUEBLA AND OAXACA POTTERY.

The Puebla pottery is a more or less crude earthenware, having a white, or rather grayish-white, ground, with decorations usually in the delft blue shades, although browns and yellows sometimes appear. The Puebla tiles are a famous characteristic of the city of the same name; in fact, Puebla is a city of tiles. They are everywhere used—on the domes of churches, façades of residences, and on walls and floors. The decorations are usually medieval in design and, though somewhat crude, not inartistic. Puebla ware is known as "Talavera."

The pottery made in Oaxaca is green glazed ware, and includes articles for table and kitchen use.

The principal output of all varieties of Mexican pottery is at present for domestic use. With the exception of that purchased and sent to the United States by American tourists very little is exported.

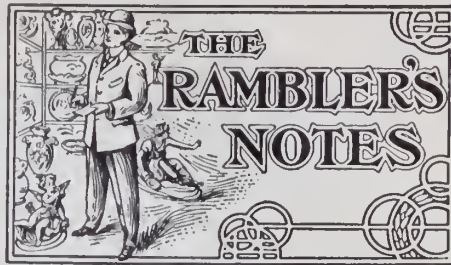

NOVELTIES IN CUT GLASS.

THE attractive display of cut glass at the New York salesrooms of the Maple City Glass Co., 253 Broadway, New York, contains many offerings of interest to jewelers visiting the city. Included in the display are compotes in a number of styles, one of which has a rounded base from which rises a gracefully shaped stem supporting the body of the dish, which is cut in intricate patterns. Sugar and cream sets in a variety of patterns offer the buyer an opportunity to make a careful selection, while the display of cigar jars and marmalade jars is equally as tempting. Cover and plate sets for use as butter dishes, etc., are shown in a number of styles and cuttings. One has the star pattern worked out as a central idea. Candy boxes, dainty jewel boxes and glove boxes are also included in the offerings now on exhibition. An attractive line of candlesticks of different sizes and patterns is shown, together with a well selected display of vases.

NEW EFFECTS IN CLOCK SETS.

AT the salesrooms of the Seth Thomas Clock Co., 51 Maiden Lane, New York, are displayed a varied and attractive assortment of clock sets, comprising a wide variety of patterns. Among these is an attractive set known as a "Dauphin," finished in rich gold and highly burnished. The clock is equipped with a cathedral bell, half-hour strike, and has a four-inch porcelain dial. The clock is supported by gracefully curved legs, and is surmounted by an attractive crest effect. About the face is a wreath of flowers, and a spray of the same flowers is used as a decorative design below the dial. The clock stands 18½ inches high and has a base of 8½ inches. The candelabra included in the set are finished in keeping with the clock, and are provided each with four gracefully curved arms supporting cups for the reception of candles. The candelabra are 22 inches high.

ARTISTIC ELECTROLIERS.

"L'ÉVAPEUR" is the name given an attractive electrolier seen at the salesrooms of L. D. Bloch & Co., New York. It shows a draped figure of a graceful woman standing beside a miniature upright steam engine and boiler. Above her head are four electric light bulbs. The figure of the woman and the engine stand on a round base. Another subject, "L'Electricité," is seen at the same salesrooms, and shows instead of the steam-driven machine an electric motor.

THE RAMBLER.

Fans

in endless variety from the cheapest to the best, for weddings, confirmation and graduation.

SEND FOR SELECTION, MENTIONING PRICE

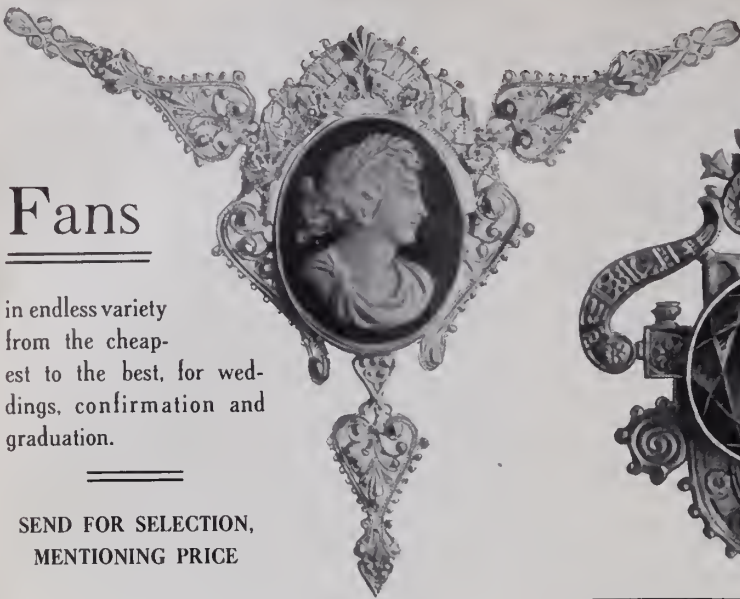

Novelties for Easter

in Necklaces, Buckles, Belt Pins, Brooches, Hat Pins, Collars, in sterling silver and gold plated, set with semi-precious and imitation stones: lapis, coral, amethyst, topaz, etc. Also an extensive line of Cameo Jewelry.



LEWY & COHEN

IMPORTERS

530 Broadway Cor. Spring St. NEW YORK

The "SECURITY" Necklace Clasp

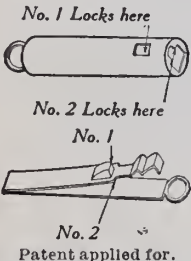

HEAR IT SNAP
Absolutely Secure and Simple. Cannot Pull Out
LOCKS IN TWO PLACES
Making it Doubly Secure
The Only Perfect Clasp

Ask Your Jobber or Write.

PRICES TO THE TRADE:

No. 1	10-Karat	- -	\$6.00 doz.
"	1-B. 10	" "	7.00 "
"	1. 14	" "	7.00 "
"	1-B. 14	" "	9.00 "
"	2. 10	" "	9.00 "
"	1. Platinum	" "	18.00 "
"	1. Gold Filled	" "	2.00 "
"	1-B. "	" "	2.25 "
"	2. "	" "	2.50 "
"	1. Sterling Silver	" "	2.00 "

The Hoffman Novelty Co.,

"CLINCH"



Safety Catch for Scarf Pins

Does not mar the pin. Nothing to get out of order. Simple and neat.

One turn to the right grips like a vise.

..FITS ANY SIZE PIN..

PRICES TO THE TRADE

No. 1	Gold Plated	\$1.50 doz.
No. 2	Roman Gold	2.00 doz.
No. 2	14k G'ld Pl'te	2.25 doz.

No. 1, 25c.

Makers, 79-83 No. Pearl St., ALBANY, N. Y.

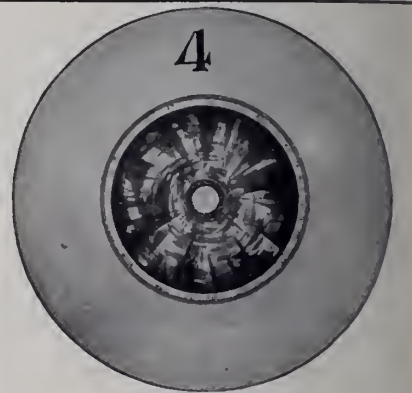

(Pat. applied for.)

Balance Hole Jewels. Size of the hole numbered on setting. Saves time and duplication. You can order just what you want. If your jobber does not handle them, send to us. Made for all kinds of American movements.

Ruby and Sapphire, \$1.25 per dozen

THOS. J. JUZEK & CO., Elgin, Ill.

JANITSCHKE COMPANY, Inc.

33 UNION SQUARE, NEW YORK CITY

Manufacturers of Patented **DIES** for the Silver and Metal Trade

ARTISTIC CASTINGS OF EVERY DESCRIPTION FOR THE SILVER AND JEWELRY TRADE

Iron Hubs and Bronze Forces, False Core Work and Undercut Castings with Elastic Patterns. Fine Plaster Castings by the *Janitschek Patent* Superior to the Asbestos Process

TELEPHONE, 400 STUYVESANT

CROUCH & FITZGERALD



Jewelry Trunks and Cases

177 Broadway, Bet. Cortlandt and Dey Sta.

688 Broadway, 723 6th Av., New York.

RIBBONS

plain and fancy designs Made to Order, in large or small quantities, to use with medals and for club purposes. :: :: :: Correspondence invited.

JOSEPH LOTH & CO., Manufacturers, 65 Greene Street, New York



Case Screw Washer **URICH PERFECT FITTING**

Case Screw Washer

Easily adjusted and holds the movement securely even when case shoulder is worn away.
Prices: Gross, \$1.50; Package, 4 doz. assorted, 50c; single doz., 15c.

For sale at all material houses or direct

S. URICH, P. O. Box 1942, New York City

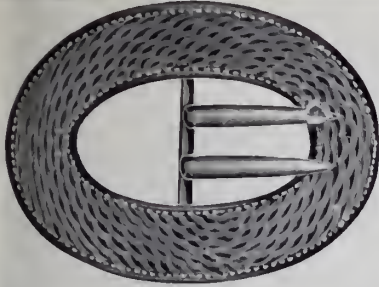

Engine Turned
Buckles and Belt Pins

4 Styles . \$9.00 a Doz.

Silver, Gilt, Oxidized or
Gun Metal Finishes

Quality Guaranteed

(Other Styles up to \$18.00 a Doz.)

Artistic, But Inexpensive

PRODUCTS OF

The "Apollo Studios"

WILL INCREASE YOUR
SPRING SALES

Bernard Rice's Sons

PROPRIETORS

544 BROADWAY

Works and Studios } 4-6 Marion St.
 } 205-207 Lafayette St. **NEW YORK**



No. 471—ELECTROLIER
(Patent applied for)

Height, 20 in.—2 Lights
Copper Bound Leaded Glass
Shade, 17 in. Diam.

PRICE, \$16.00

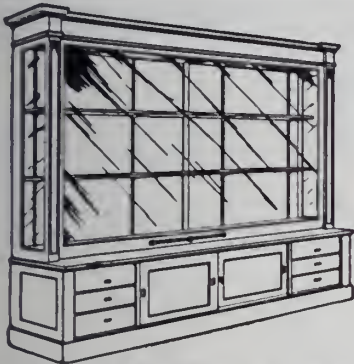

Jewelry Store Fixtures and Show Cases

OUR SPECIALTY

The enlargement of our factory in our new location enables us to quote low prices.

If you need fixtures or show cases let us hear from you. Estimates cheerfully furnished.

ALEXANDER H. REVELL & COMPANY, Rees, Dayton, Eastman and Hawthorne Sts., **CHICAGO, ILL.**

NOVELTIES

FANS

For the Jewelry Trade

A complete stock of unusual and exclusive designs

Louis Steiner

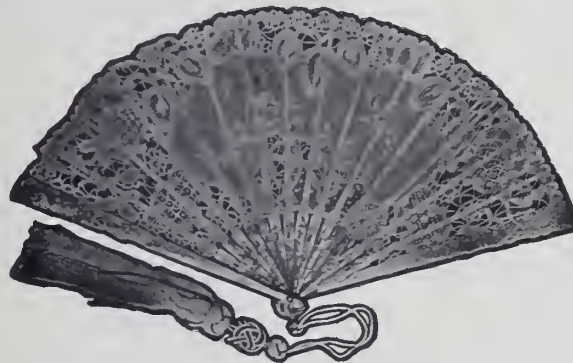

NOVELTIES

FANS

of Every Description

An assortment of Fans that is unequalled in this country

520 and 522 BROADWAY
NEW YORK



LEMAIRE OPERA GLASSES

LEMAIRE FIELD GLASSES

Best in the World. Used in the Army and Navy.

SUSSFELD, LORSCH & CO., Importers

37 MAIDEN LANE, NEW YORK



All Genuine Glasses
Bear This Mark
Large Variety in All
the Latest Styles

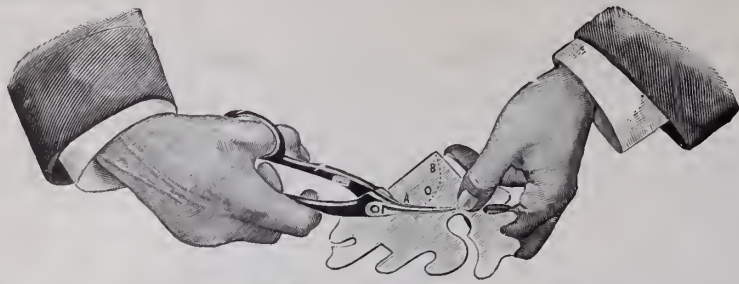

A Shear that will cut any kind of design to perfection. Better have a pair—they are mighty useful.

Scissor handle, Jap., 7½ in., \$2.00
Plain " bright, 6½ in., 1.50

WILLIAM DIXON, Incorporated 39 John St., New York
Formerly F. W. Gesswein Company

LEES & SANDERS,

FROM THE SWEEP PRODUCER DIRECT
TO THE UP-TO-DATE SMELTERS

SWEEP SMELTERS, BIRMINGHAM, ENG.

HONEST AND
PROMPT RETURNS FOR YOUR OLD GOLD, SILVER FILINGS, SWEEPINGS & C.

WE BUY

Old Gold and Silver Filings, Polishings, Sweeps, Hand Washings, etc. We will make accurate valuations and hold consignment subject to your acceptance. If valuation is not satisfactory, we reship to you at our expense.

WE PAY FOR OLD GOLD:

22 K. 88c. per dwt.	12 K. 48c. per dwt.
20 K. 80c. " "	10 K. 40c. " "
18 K. 72c. " "	8 K. 32c. " "
16 K. 64c. " "	6 K. 24c. " "
14 K. 56c. " "	4 K. 16c. " "

MARKET RATES FOR SILVER AND PLATINUM

Try us and you will Appreciate our Squareness, Promptness and Accuracy.

T. B. HAGSTOZ, Ltd., Main Office, 709 Sansom St., Philadelphia, Pa.
SMELTERS, ASSAYERS, REFINERS.

WE SELL

Gold, Silver and Platinum, various qualities, rolled flat or drawn to wire of any gage.

PRICES OF ALLOYED GOLD:

8 K. 42c. per dwt.	14 K. 66c. per dwt.
10 K. 50c. " "	16 K. 74c. " "
12 K. 58c. " "	18 K. 82c. " "

Gold and Silver Solder, either from formulas furnished, or our own. "T. B. H." Alloy, 25c. per oz. Guinea Gold, 75c. per lb. Shot Copper, 40c. per lb. We will send tables for alloying without charge. They save figuring.

'Phone 3759-R.

WM. F. RENZIEHAUSEN CO.

43-47 Oliver Street, NEWARK, N. J.

Gold and Silver Refiners

PROMPT RETURNS MADE FOR ANY MATERIAL CONTAINING PRECIOUS METALS
DEALERS IN GOLD AND SILVER, AND ROLLERS OF STERLING SILVER

Gold and Silver Anodes a Specialty

ESTABLISHED 1886

CEO. M. BAKER

TELEPHONE UNION 1493-R

Gold and Silver Refiner and Sweep Smelter

Office, 91 Page St. }
Works, 77-85 Page St. } PROVIDENCE, R. I.

Our processes are strictly up to date and facilities most complete for doing all kinds of refining.
Specialties: Prompt and good returns.

CASTINGS

Gold, Silver, Bronze, Brass, German Silver, Copper and Iron.
L.D. TEL. 2072 L. Supply Jewelers, Silversmiths, Die-makers, Mould-makers, etc. Bronze Forces, Hard Bronze and Iron Shells for Die-cutting Machines. Cast Iron Hub for sinking in Steel Dies. Chandelier, Undercut Work, Statuary.

AUGUST GRIFFOUL 313 HALSEY STREET NEWARK, N. J.

The Ackley Engraving Block

AND "JOKER" ATTACHMENT



Pat. March 20, 1906

Made by Engravers who saw the need of a Handy Time Saving Block

THE BEST IS THE CHEAPEST

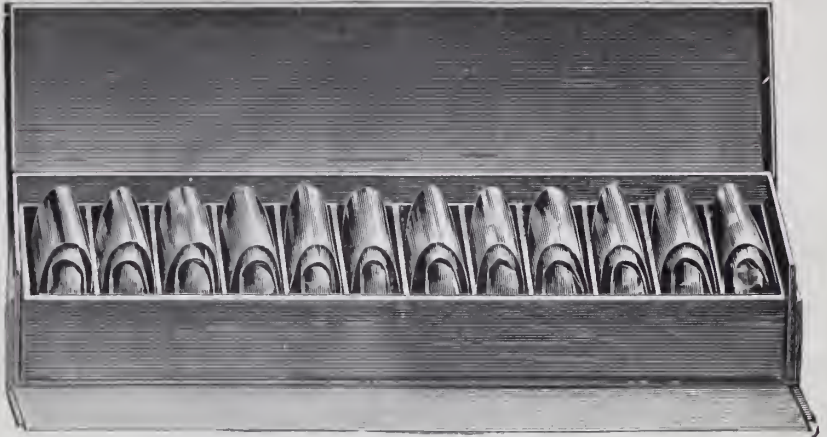

Why the "LAFAYETTE MAINSPRING" is superior

1st—It is guaranteed to be made of the Best Steel. 2d—It is made by Skilled Hand Labor. 3d—Each Spring is wrapped in Oil Paper and Silver Foil, which packing positively avoids exposure to the moisture of the air, and therefore all danger of rust is prevented. 4th—Each Spring bears a metal Tag, indicating the watch it is intended for, which accuracy is warranted. 5th—Each dozen is put up in a neat Box, having twelve partitions, one for each spring, so the handling of several springs at one time is avoided. 6th—The finish of the "Lafayette Spring" is, like its quality, superior to any in the market.

THE ACKLEY ENGRAVING BLOCK: Always ready to hold any article. No hunting for pins. The patent friction pins all remain in the head. Simply pull up to the desired height the ones needed. Each pin is numbered on top to designate size of groove or notch in it. They are so arranged in the head that they will readily hold all large or small articles either by three or more points of contact. The swivel jaw can be locked rigidly in an instant. The key will not fall off, yet it may be removed instantly. The patent base eliminates all unnecessary weight and gives the same movement as the old ball and socket base. This block is the result of years of practical experience of engravers who know the wants of engravers. There is nothing complicated about it to wear out or get out of order. Workmanship and materials are the best. Each part is copper plated before being heavily nickel plated, thus insuring a fine durable finish. Height, 6 $\frac{3}{8}$ inches. Diameter of head, 2 $\frac{1}{2}$ inches. Diameter of base, 6 inches. Weight, 8 pounds. **THE "JOKER" ATTACHMENT,** as shown beside the block, holds large and small signet and band rings, cuff buttons, collar buttons, signet pins, etc., firmly, without marring. It may be used on any block.

HENRY ZIMMERN & CO., Inc., 77 John Street
New York City
Exclusive Wholesale Distributors for U. S. and Canada

CRUCIBLES.

Jewelers' Supplies,
Etc.
Established 1850.
J. & H. BERGE,
96 John Street,
NEW YORK.

J. H. GALAWAY P. H.
ENGRAVERS
CRESTS, MONOGRAMS and LETTERING
7 Maiden Lane, Rooms 44-45
Established over 35 years

PATENTS

obtained on inventions and designs. Trade marks, prints and labels registered.
R. W. BISHOP,
ATTORNEY-AT-LAW,
908 C Street N.W., Washington, D.C.

JOHN AUSTIN & SON

Assayers, Refiners and Smelters
74 & 76 Clifford Street PROVIDENCE, R. I.
We Do Our Own Smelting.

L. LELONG & BRO.

Gold and Silver Refiners, Assayers and Sweep Smelters
S. W. Cor. Halsey and Marshall Sts., NEWARK, N. J.
Prompt attention given to Gold and Silver Bullion.
SMELTING FOR THE TRADE.

UNITED STATES SMELTING AND REFINING WORKS

L. & M. WOLLSTEIN

16 JOHN STREET, NEW YORK
SWEEP SMELTERS AND ASSAYERS
Dealers in Gold and Silver Assay Office Bars. HIGHEST and MOST PROMPT RETURNS made for Sweeps and all kinds of Waste containing precious Metals.
HIGHEST PRICES PAID FOR OLD GOLD AND SILVER
Manufacturers of STERLING SILVER. Importers of PLATINUM. Ore and Bullion Assays a Specialty.

A Few Words About Mainsprings

Spectacle and Eyeglass Strap Plier No. 105

Price, each, \$1.25

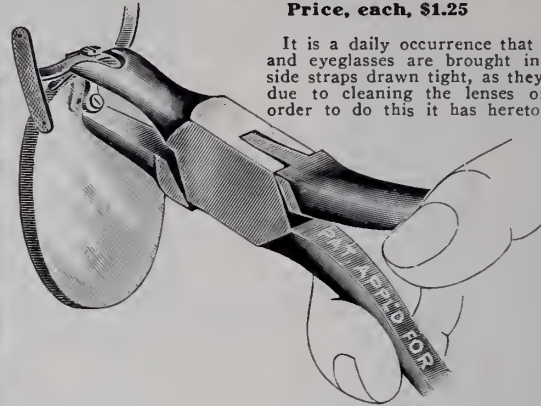

It is a daily occurrence that frameless spectacles and eyeglasses are brought in to have the small side straps drawn tight, as they have become loose, due to cleaning the lenses or other causes. In order to do this it has heretofore been necessary to remove the lenses from the mountings, and as all know, this very often results in breaking or chipping the lenses.

By the means of this plier this can be avoided and the work quickly done.

All that is required is to loosen the screw two or three turns, clamp the frame as shown in the illustration, and bend the straps to the lenses.

Retighten the screw, and the work is done.

DO NOT NEGLECT to loosen the screw, as otherwise a good job cannot be done, and the lenses are likely to be broken.

Made of best quality Swedish steel, nickel-plated.

There is no article of material used by the watchmaker or the watch repairer about which, if he be a careful and thorough workman, he feels more solicitous than the *Mainspring*. Next to the fragile watch glass, the mainspring is more frequently replaced than any other article used in watch repairing. While the percentage of breakage is high in all watch springs, it jumps into appalling proportions when they are of an inferior quality, unless their temper is so low as to make them almost useless, and certainly of little value in watches that are to serve the purpose of timekeepers. When we offer you the *Ulysse Sandoz Robert* spring, we feel confident that you are getting the best that skillful hands and lifelong experience can produce.

Made for all American Watches. Per dozen, \$1.25

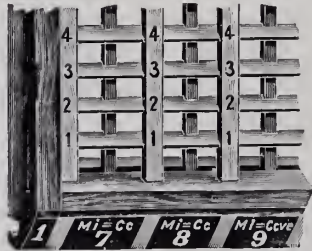

Top View, Showing Skeleton Frame of Drawer. Accumulation of dust and chips is impossible.

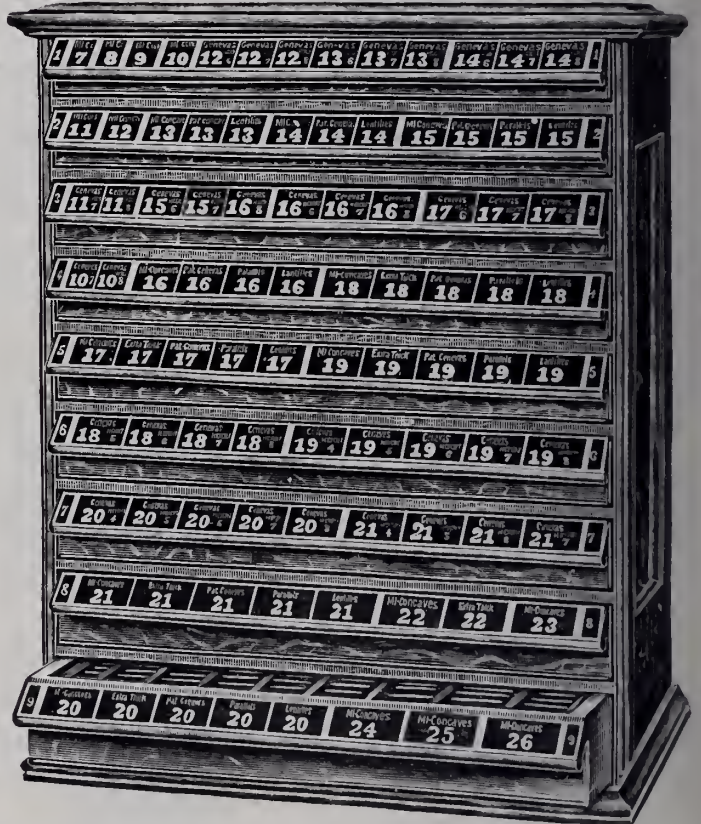

Echarco Watch Glass Cabinet No. 15 (Patented)

Price, each, \$16.00

This cabinet has many new features not found in any other. Novelty and usefulness are the chief arguments in its favor.

CONSTRUCTION AND MATERIAL.—The cases are made of oak, finely finished and of attractive appearance. Sides are paneled. Partitions of basswood and put together in best manner possible.

PARTITIONS are skeleton, preventing accumulation of dust, chips, etc.

BOTTOMS of cabinets are hollow to receive chips, dust, etc.

ARRANGEMENT FOR GLASSES.—The 9 drawers contain 1,547 spaces to hold glasses in upright position.

Labeling of drawers as shown in cut is on the pulls of the drawers and done in gold bronze on black background.

DIMENSIONS.—24 inches wide, 29½ inches high, 12 inches deep; weight, 45 lbs.; with packing case, 75 lbs.

The construction of drawers, the arrangement of partitions to economize space and weight, and the novel method of showing contents on drawer-pulls are all prominent characteristics and extremely well thought of.

FOR SALE BY ALL JOBBERS IN THE UNITED STATES AND CANADA

HAMMEL, RIGLANDER & CO.

47-49 Malden Lane
New York

THE JEWELERS' CIRCULAR

WITH WHICH ARE CONSOLIDATED

THE HOROLOGICAL REVIEW,
 THE JEWELERS' WEEKLY,
 THE JEWELERS REVIEW

Copyright 1908 by
 The Jewelers' Circular
 Publishing Company.

11 John St., Corner Broadway, New York.

Entered as second-class matter at the New York, N. Y., Post Office.

40th Year

WEDNESDAY, MARCH 18, 1908.

Vol. LVI., No. 7.

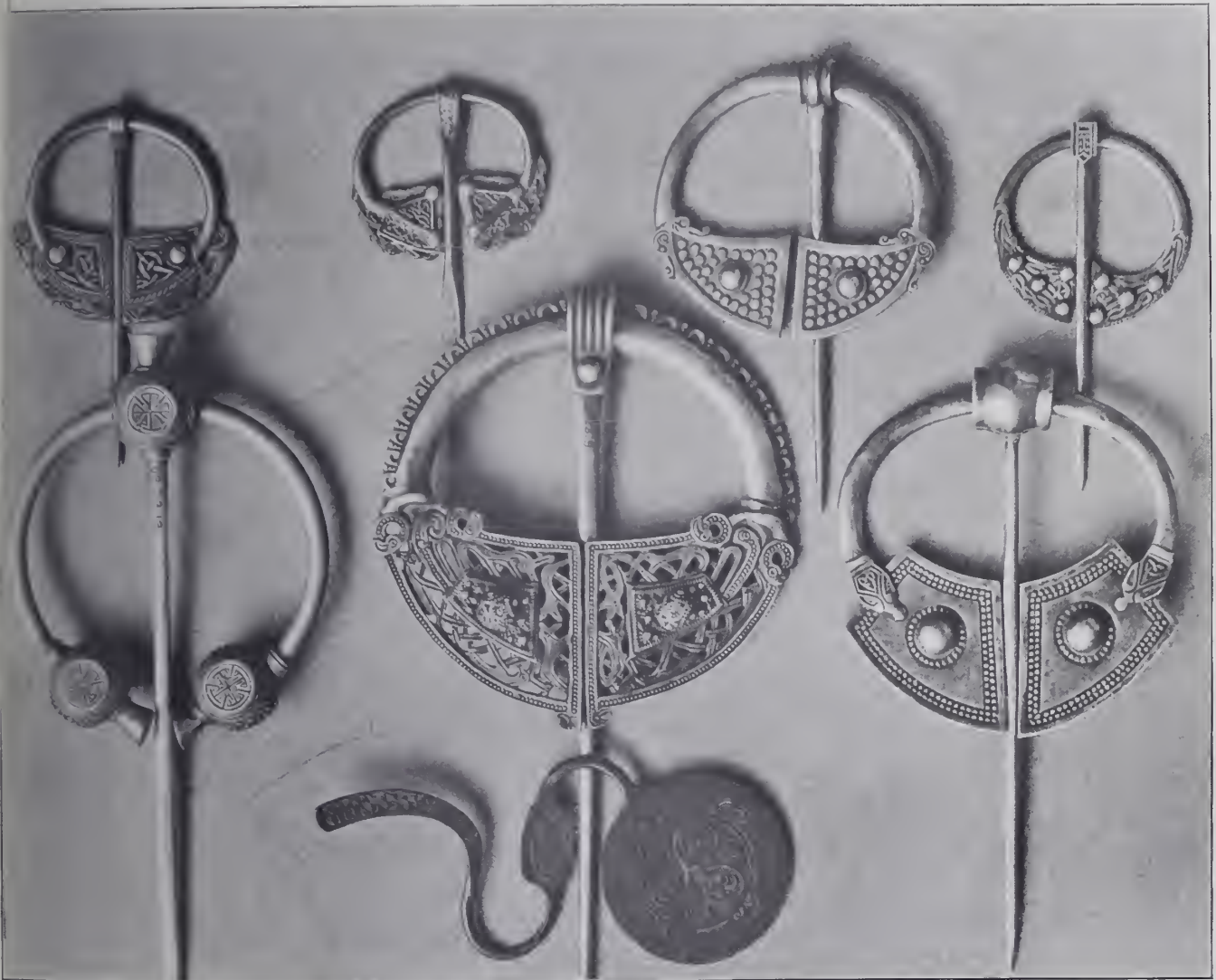

Reproductions of Antique Irish Brooches in the Metropolitan Museum of Art, New York.

(See Text on Page 39.)

ALVIN SILVER

The New Alvin Plate surpasses anything ever made in Plated Silver Ware.

MADE IN ONE QUALITY ONLY—THE BEST. Must be seen to be appreciated. Send for samples.

Price list will be sent to all Jewelers in the next few days. Please notify us if you do not receive it.



BRIDE'S BOUQUET.



LILY.



ALVIN MFG. CO.

SILVERSMITHS

NEW YORK

Fahys

A bill which we do not approve of, has been introduced in Congress prohibiting the stamping of any guarantee in Gold Filled Watch Cases. We are advised by eminent counsel that any law intended to prohibit a legitimate manufacturer from stamping his goods with a guarantee would be unconstitutional.

We not only stamp our guarantees in our cases, and back them up, but we propose to continue doing so, and thus fully protect the Retail Jeweler. Our business has been established for half a century, and we expect to continue it for another half century.

We appreciate the confidence and support shown us by the Retail Jeweler and are determined to continue meriting same.

WE ARE NOT MEMBERS OF ANY WATCH CASE TRUST

JOSEPH FAHYS & CO.

New York

Boston

Chicago

San Francisco

"STRIKE WHILE *the* IRON *is* HOT"

Make Money --
Good
Honest
Dollars



By buying diamonds from us you get the best value obtainable, so you can sell them at a fair profit, and at the same time give your customer proper value for his money

J. R. WOOD & SONS

DIAMOND CUTTERS

2 Maiden Lane, Corner 170 Broadway

NEW YORK

SAFETY



Perfect Safety

from dissatisfied customers is assured to those retail jewelers who handle our wedding rings.

Don't be left "out at sea" by selling rings not up to quality represented, or cast rings that do not wear properly.

We invite you to "ride ashore" to absolute safety.

J. R. WOOD & SONS

WEDDING RING MAKERS

2 Maiden Lane Corner 170 Broadway

NEW YORK

The Big Dipper

Will Dip Up Profits For You



THE
BEST IN EVERY
GRADE

CHICAGO
701 Heyworth Bldg.

Ask your Jobber

NEW YORK
Maiden Lane

STAR WATCH CASE CO.

LUDINGTON, MICHIGAN

COPYRIGHTED BY T. F. KENNEDY

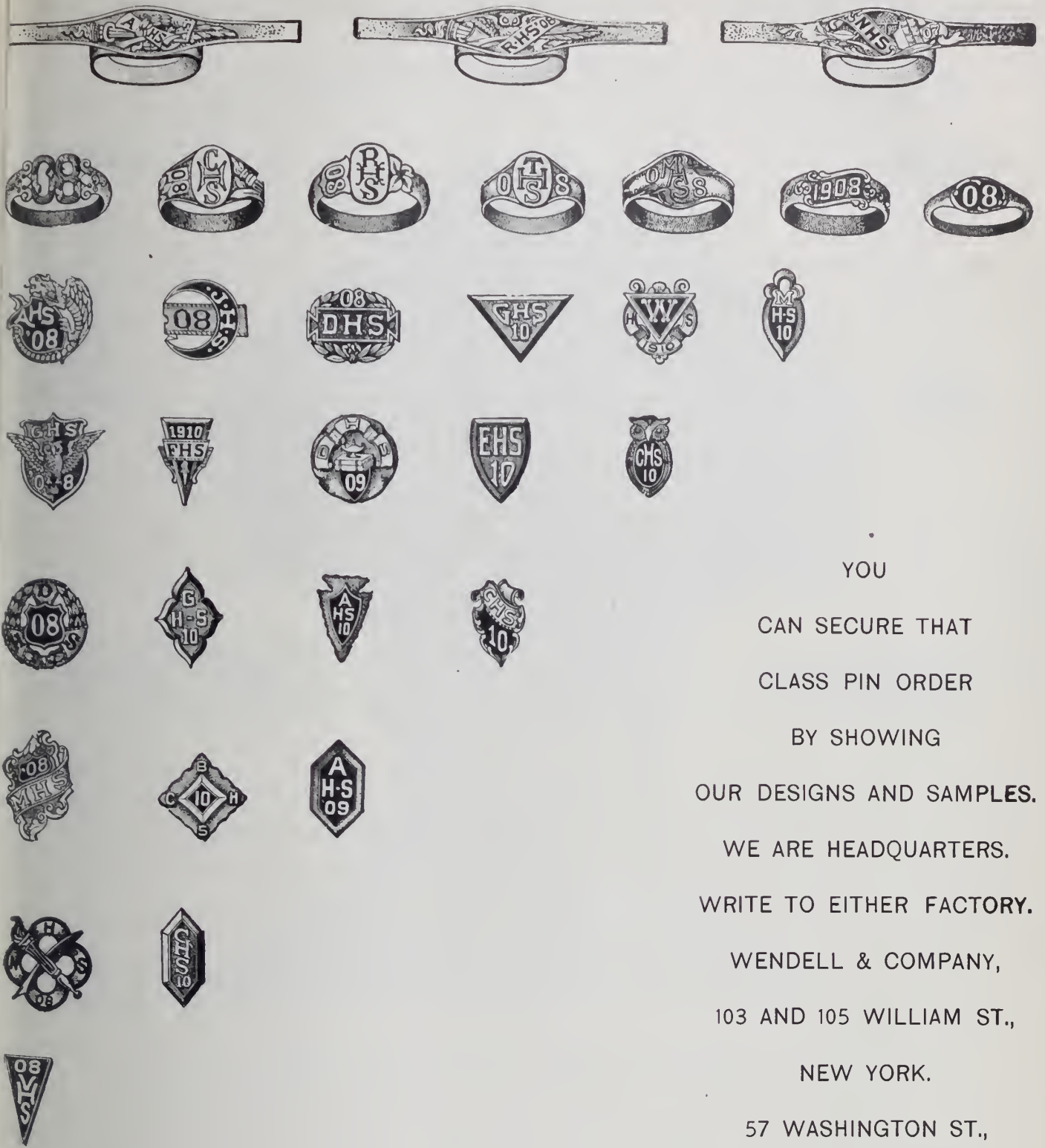

YOU
 CAN SECURE THAT
 CLASS PIN ORDER
 BY SHOWING
 OUR DESIGNS AND SAMPLES.
 WE ARE HEADQUARTERS.
 WRITE TO EITHER FACTORY.
 WENDELL & COMPANY,
 103 AND 105 WILLIAM ST.,
 NEW YORK.
 57 WASHINGTON ST.,
 CHICAGO.

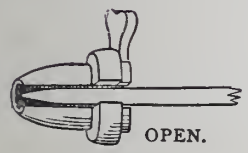

OPEN.

WENDELL'S PERFECT SAFETY CATCH

SETS CLOSE TO BODY OF PIN.
 PROTECTS POINT OF PIN TONG.
 HANDILY LOCKED AND UNLOCKED.
 ABSOLUTELY SECURE.

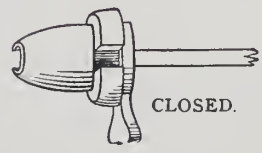

CLOSED.



Wolcott Manufacturing Co.



“Fashion”

Collar Pins



PATENTS PENDING

An Absolutely New Article which Sells at Sight. Try It.

MANUFACTURED IN ROLLED PLATE BY

Wolcott Manufacturing Co.

71 Peck St., Providence, R. I.

New York Office, 14 Maiden Lane

MANUFACTURED IN 10KT. SOLID GOLD BY

JOHN T. MAURAN MFG. CO., Providence, R. I.

DECADES OF HISTORY

HOW OFTEN we find historic periods reckoned in "decades" —periods of ten years and multiples of ten. Among sovereigns it's a long reign that extends over two decades. No less than five Presidential elections transpire in the same period. Over such a stretch of time, if not even longer, extends the life of the

WADSWORTH 20-YEAR

Case. During these decades the history of the case itself is interesting. It begins with the sale of a good looking, good wearing article, well made, attractively priced. It begins with good profit to the jeweler. The case keeps on looking well, working well, serving well. The jeweler keeps his customer. The makers keep their reputation.

Attains Its Majority

The Wadsworth Watch Case Co.

FACTORY
DAYTON, KY.

CHICAGO
COLUMBUS BUILDING

SAN FRANCISCO
717 MARKET STREET

NEW YORK
49 MAIDEN LANE



31



32



33



34



35



36



37

12 SIZE
 SOLID
 GOLD
Dueber Cases
 WHICH ARE SURE
 TO PLEASE.

A Few Words About Mainsprings

Spectacle and Eyeglass Strap Plier No. 105

Price, each, \$1.25

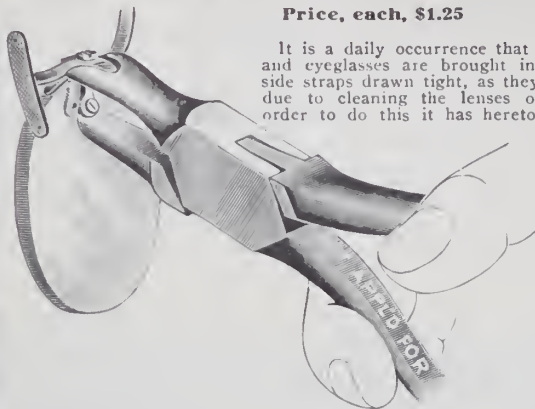

It is a daily occurrence that frameless spectacles and eyeglasses are brought in to have the small side straps drawn tight, as they have become loose, due to cleaning the lenses or other causes. In order to do this it has heretofore been necessary to remove the lenses from the mountings, and as all know, this very often results in breaking or chipping the lenses.

By the means of this plier this can be avoided and the work quickly done.

All that is required is to loosen the screw two or three turns, clamp the frame as shown in the illustration, and bend the straps to the lenses. Retighten the screw, and the work is done.

DO NOT NEGLECT to loosen the screw, as otherwise a good job cannot be done, and the lenses are likely to be broken.

Made of best quality Swedish steel, nickel-plated.

There is no article of material used by the watchmaker or the watch repairer about which, if he be a careful and thorough workman, he feels more solicitous than the *Mainspring*. Next to the fragile watch glass, the mainspring is more frequently replaced than any other article used in watch repairing. While the percentage of breakage is high in all watch springs, it jumps into appalling proportions when they are of an inferior quality, unless their temper is so low as to make them almost useless, and certainly of little value in watches that are to serve the purpose of timekeepers. When we offer you the *Ulysse Sandoz Robert* spring, we feel confident that you are getting the best that skillful hands and lifelong experience can produce.

Made for all American Watches. Per dozen, \$1.25

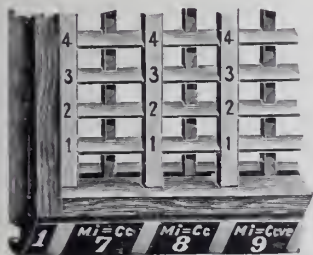

Top View, Showing Skeleton Frame of Drawer. Accumulation of dust and chips is impossible.

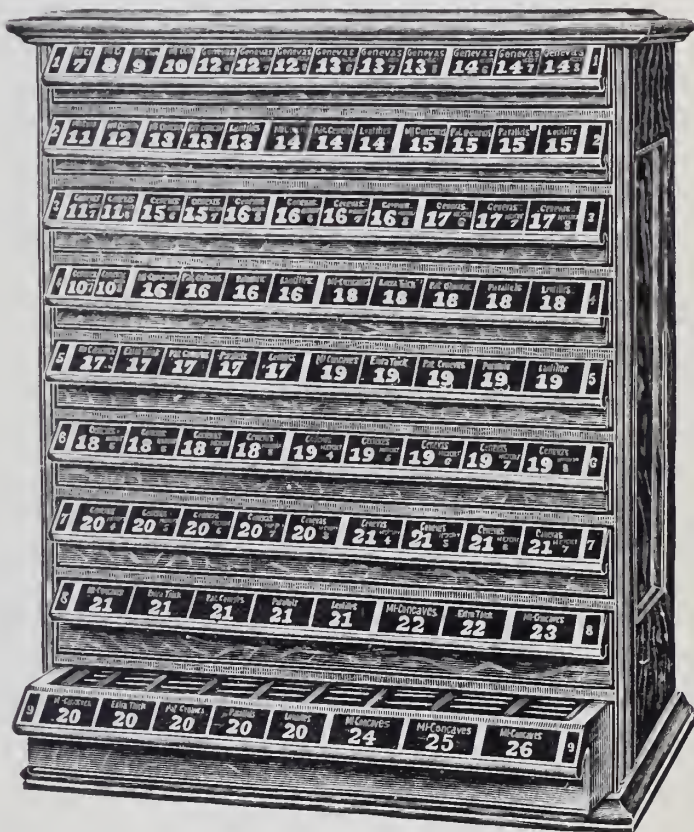

Echarco Watch Glass Cabinet No. 15 (Patented)

Price, each, \$16.00

This cabinet has many new features not found in any other. Novelty and usefulness are the chief arguments in its favor.
CONSTRUCTION AND MATERIAL.—The cases are made of oak, finely finished and of attractive appearance. Sides are paneled. Partitions of basswood and put together in best manner possible.
PARTITIONS are skeleton, preventing accumulation of dust, chips, etc.
BOTTOMS of cabinets are hollow to receive chips, dust, etc.
ARRANGEMENT FOR GLASSES.—The 9 drawers contain 1,547 spaces to hold glasses in upright position.
 Labeling of drawers as shown in cut is on the pulls of the drawers and done in gold bronze on black background.
DIMENSIONS.—24 inches wide, 29 1/2 inches high, 12 inches deep; weight, 45 lbs.; with packing case, 75 lbs.
 The construction of drawers, the arrangement of partitions to economize space and weight, and the novel method of showing contents on drawer-pulls are all prominent characteristics and extremely well thought of.

FOR SALE BY ALL JOBBERS IN THE UNITED STATES AND CANADA

HAMMEL, RIGLANDER & CO. 47-49 Maiden Lane
New York

Purses for all Purses

WHY LOOK ELSEWHERE TO SUPPLY YOUR STOCK?

From the simple and inexpensive trinket of the unassuming to the most aristocratic and costly conceits. Each grade conceived to meet the taste of some one element of society and all together constituting a line of the greatest possible extent. In the designing, etching and engraving the whims of all the feminine world have been studiously consulted and artistically incorporated with the idea of producing something appealing and consequently easily sold.

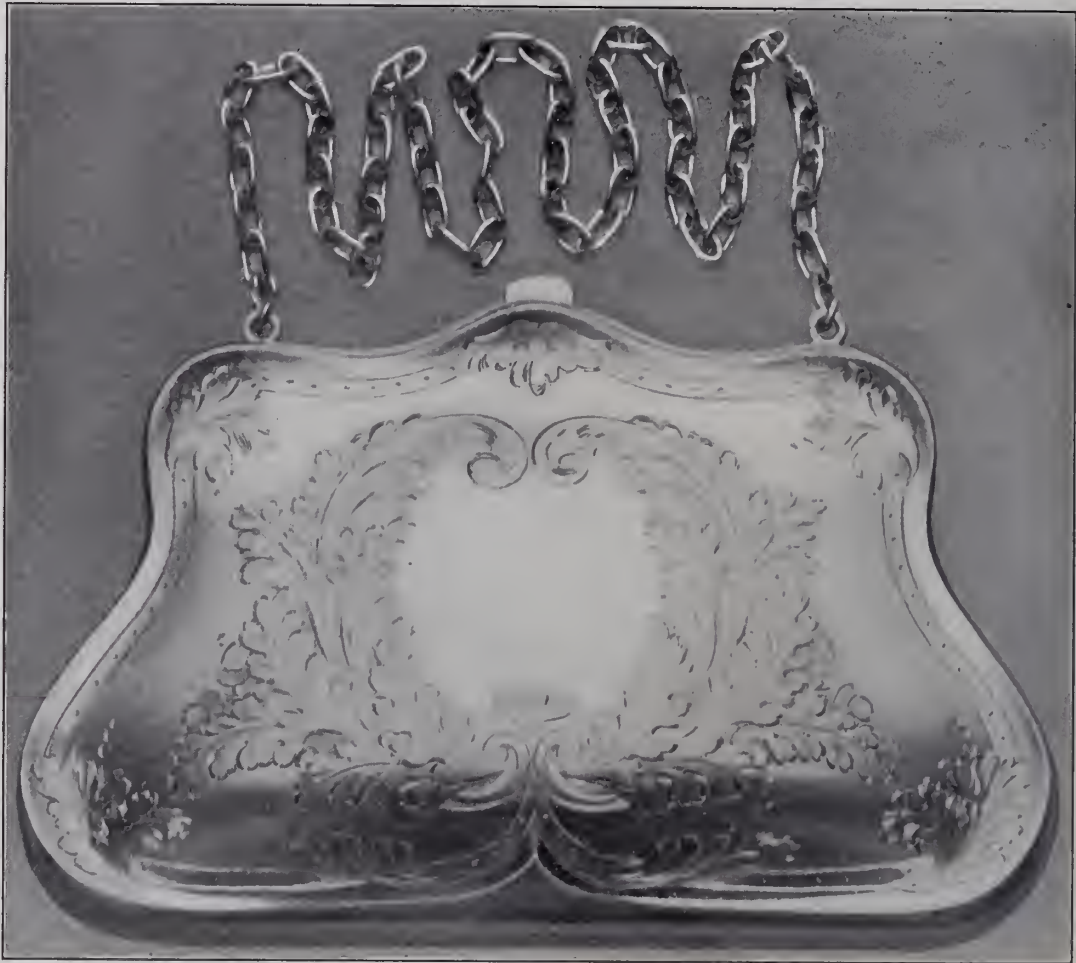

The line must recommend itself to the jeweler carrying combination purses and card case, and satchel shaped box purses, for the reason that we can supply these novelties in a practically unlimited variety, from the smallest to the largest made. We have oblong or satchel shaped purses with silk or leather linings; several sizes of vanity boxes, with silver compartments or leather lined, with puff, mirror, pencil tablet and change compartments, and many others, all of sterling silver, that we couldn't begin to enumerate in this space. See the line to understand it.

Representative jewelers are invited to send for a selection. State whether high, medium or low-priced goods are desired.

R. BLACKINTON & CO.

ESTABLISHED 1861. SILVERSMITHS

Factory, North Attleboro, Mass.

3 MAIDEN LANE, NEW YORK

TRADE  MARK

WHITING MFG. COMPANY

Silversmiths



The Situation

The Whiting Company, being in close touch with the jewelry trade of the entire country, naturally find themselves exceptionally well informed as to the prevailing business conditions and sentiment.

This knowledge leads them to the belief that in these times of "close buying" it is incumbent upon the retail dealer to make his stock more than usually attractive by the addition to it of such goods as shall compel his customers' attention.

For this reason the Whiting Company have confined themselves this season to the production of such goods as shall be absolutely convincing, owing to their moderate price combined with their excellence of quality and individuality of design.

BROADWAY AND NINETEENTH STREET
NEW YORK

SAN FRANCISCO, CAL.
717 Market Street

STERNAU
Coffee-Machine
with
Sterno-Inferno Burner



Made in Nickel-plate, Copper
and Silver-plate

NEW CONTRIVANCES

are always made to save labor and to better the conditions in every line of business.

The Sternau Coffee-Machine saves labor and produces the best flavor of the coffee obtainable.

It does not boil coffee but distils it—thus extracting only the wholesome properties and keeping the beverage free from bitterness.

Connoisseurs will not be without a Sternau Coffee-machine.

As the Sternau Coffee-machine makes perfect coffee conveniently it is in demand.

Write to-day for our catalogue showing the different styles and quoting prices.

S. STERNAU & CO.

Makers of

Coffee-machines, Fancy Teakettles, Chafing-dishes and their Accessories, Smoking Sets, Alcohol Stoves, Coffee and Tea Pots, etc.

New York Showrooms
BROADWAY, COR. PARK PLACE
Opposite Post Office

Office and Factory
195 PLYMOUTH STREET
BROOKLYN, N. Y.

If it's for an Alcohol Lamp, we make it.

HAT PINS
FOR
EASTER



AT
TEMPTING
PRICES

GIFTS will be bestowed this coming Easter as usual, but purchasers will be cautious as to the amounts they are willing to spend. This special line of Easter Hat Pins fits right in with prevailing conditions—combining appropriate colors and effects with very moderate prices. You can retail them profitably at from \$1.00 to \$3.00. There is business in them. AMETHYST, TOPAZ, LAPIS LAZULI, etc.

D. Lisner & Co. *Creating Importers of* **Jewelry Novelties**
One-Forty Fifth Avenue, cor. 19th St., NEW YORK

COMPLETE YOUR STOCK WITH RIGHT GOODS

GOLD RINGS

Gold Scarf Pins

Gold Brooches

A Handsome Line of Seamless Wire GOLD FILLED RINGS

All ready for prompt delivery to the Jobber

OSTBY & BARTON CO.
PROVIDENCE, RHODE ISLAND

New York Office
9-13 MAIDEN LANE

Chicago Office
103 STATE STREET

NEW YORK, 9 Maiden Lane
CHICAGO, 103 State Street

BATES & BACON ATTLEBORO MASSACHUSETTS

THE LEADING HOUSE FOR HIGH-GRADE GOLD-FILLED CHAINS,
LOCKETS AND BRACELETS

Something New for Easter! THE "WINNA" BRACELETS
Strongest secret joint and catch on the market

SOME OF OUR NEW DESIGNS
ORDER OF YOUR JOBBER

GENTS' VEST }
DICKENS }
SAFETY FOB } CHAINS
SECRET LOCKET }
LORNETTE }
EYE GLASS }

BRACELETS, LOCKETS, CHATELAINES



F450
E22

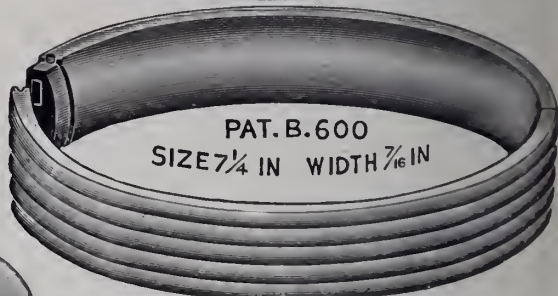

SOLD DIRECT TO THE RETAIL TRADE ONLY

FEATURES OF OUR LINE

The UNIQUE, ARTISTIC and UNUSUAL, together with BEST WORKMANSHIP, SUPERIOR QUALITY and PERFECTION IN FINISH



Brooches in gold filled or sterling silver, the gold filled finished in rose or dark green (antique). The sterling in French grey or oxidized. We use finest imitation stones and can furnish any stone or color required.

We Manufacture in GOLD FILLED and STERLING SILVER

BROOCHES, HAT PINS, COMBS, HANDY PINS, WAIST PIN SETS, BARRETTES, SCARF PINS, VEIL PINS, LINKS, BUCKLES, SASH BROOCHES, BRACELETS and NECKLACES.

C. RAY RANDALL & CO., North Attleboro, Mass.

NEW YORK OFFICE, No. 7 Maiden Lane

SAN FRANCISCO OFFICE Henry M. Abrams Co., No. 717 Market Street

Address all orders and communications to Factory, North Attleboro, Mass.



W. H. SAART
President

GEO. J. KELLEY
Treasurer

F. B. PLATT
New York Representative

F. R. TRUELL
Western Representative

The Four Men who Have Been Instrumental in Making

THE W. H. SAART CO.

ATTLEBORO, MASS.

The Leading Sterling Silver Novelty House in the United States

Bags Buckles Sash Pins Vanity Cases Hat Pins

The Best Selling "Thread" Pattern in the Trade



The SMITH "PILGRIM"

There never has been a more artistic and lasting design than the Smith "Pilgrim." It is characterized by simple elegance, refinement and dignity of design, and grateful absence of over-ornamentation. The Smith "Pilgrim" pattern will remain permanently in demand. Include "Pilgrim" in your stock. It is without question the best selling "thread" pattern in the trade to-day. Made in all the fancy pieces.

FRANK W. SMITH CO. MANUFACTURERS OF STERLING SILVERWARE Gardner, Mass.



TRADE MARK



MARGUERITE

MR. RETAILER:

That department in our factory called: "CREATION CORNER" is working overtime.

We simply won't stop creating.

It is just as natural for us to create

SNAPPY GOLD WATCH CASES, as it is for a "live wire" to spit sparks.

Some of our prettiest creations will blossom in April and any Jobber will gladly send you a few.

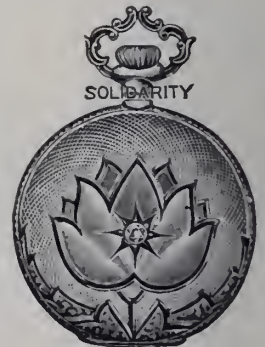

MARGUERITE

Solidarity Watch Case Company

Established 1885

54 Maiden Lane, New York

General Selling Agents:

JOHN W. SHERWOOD

:: ::

FRANK E. HARMER



THE Annual Elections of the B. P. O. E. are approaching. Presentation Pieces will be in demand. We are headquarters. Send for selections of fine Jewels, Elk Charms and Buttons. You will make good sales and add to your reputation for having "The best in the line."

HENRY FREUND & BRO.

"Sellers of Sellers"

71 Nassau St., New York

The "Rose,"



our trade-mark, is a symbol of quality and excellence



"Kotobuki"



(Pronounced Ko-to-bit-ki)

THE JAPANESE WORD FOR LONG LIFE

The Popular Craze in

SCARF PINS

Price in 14 Kt.
\$3.00

MANUFACTURED IN 14 KT. GOLD BY

Price in 14 Kt.
\$3.00

VAN DUSEN & STOKES CO.

MAKERS OF ORIENTAL JEWELRY

IMPORTERS OF CORAL AND SEMI-PRECIOUS STONES

1123 CHESTNUT STREET

PHILADELPHIA



The Original **Carmen Adjustable Bracelet**

With 20 years' experience and the best factory equipment that can be procured, we are able to produce

THE BEST IN THE WORLD FOR THE MONEY

The stamp, "The D. F. B. Co.," is a guarantee of quality and up-to-date designs. Ladies' and Gentlemen's Chains, Fobs, Lorgnettes, La Vallieres, Hat Pins, Chatelaine Pins and Bracelets.

THE D. F. BRIGGS COMPANY

ATTLEBORO, MASS.

NEW YORK OFFICE
180 Broadway

CHICAGO OFFICE
Heyworth Bldg.

ST. LOUIS OFFICE
Mermod & Jaccard Bldg.

LONDON OFFICE
118-122 Holborn E. C.

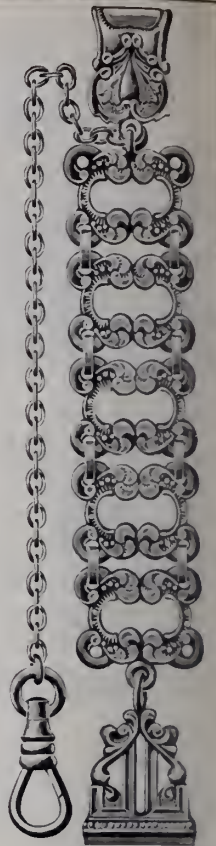

REMOVAL

We take pleasure in notifying the trade that our factory and main office is now located at

36 GARNET ST., PROVIDENCE, RHODE ISLAND.

We shall continue to produce new, attractive and quick-selling goods in our various lines of

GOLD-FILLED JEWELRY.

Larger quarters and increased facilities will enable us to render prompt and efficient service at all seasons.

We thank our customers for past favors, and solicit a continuance of their patronage.

E. A. POTTER COMPANY

Representatives:

LOUIS S. HODGES
HARRY E. FARQUHARSON

36 GARNET STREET

PROVIDENCE, RHODE ISLAND

SIMMONS ARMILLA

SHOWING more samples from the Simmons Armilla line—all excellent selling patterns and a first-rate assortment to include in your Spring display.

Simmons Armilla is a profitable bracelet to handle because its attractiveness, evident quality and reasonable cost make it a ready seller; it has, in fact, a record of sales equaled by no other joint and catch bracelet.

Almost any wholesale jewelry house will show you dozens of Armilla patterns as good as the numbers shown here—in plain, engraved, chased and stone-set designs, polished, English and Roman finish.

IF your showing of SIMMONS WATCH and LORGNETTE CHAINS and FOBS isn't as full and complete as it should be, don't delay to fill in any patterns that may be lacking.

No other goods meet the requirements of all classes of chain and fob wearers so satisfactorily in point of style, wear and actual economy as do the Simmons goods.



R. F. SIMMONS COMPANY
Main Office and Works, ATTLEBORO, MASS.

New York Salesrooms
9-13 Maiden Lane

Chicago Salesrooms
42 Madison St. (Heyworth Bldg.)

Notice

Because

A person happens to dress in black, there is no reason why they should not enjoy wearing the very latest fashions. Consequently we make all the latest fads and fancies in Mourning Jewelry, as well as a complete line of regular goods in Black Enamel.



TRADE-MARK

H. J. Hedges & Co.
Makers of 14 K. Jewelry

14 John Street
New York

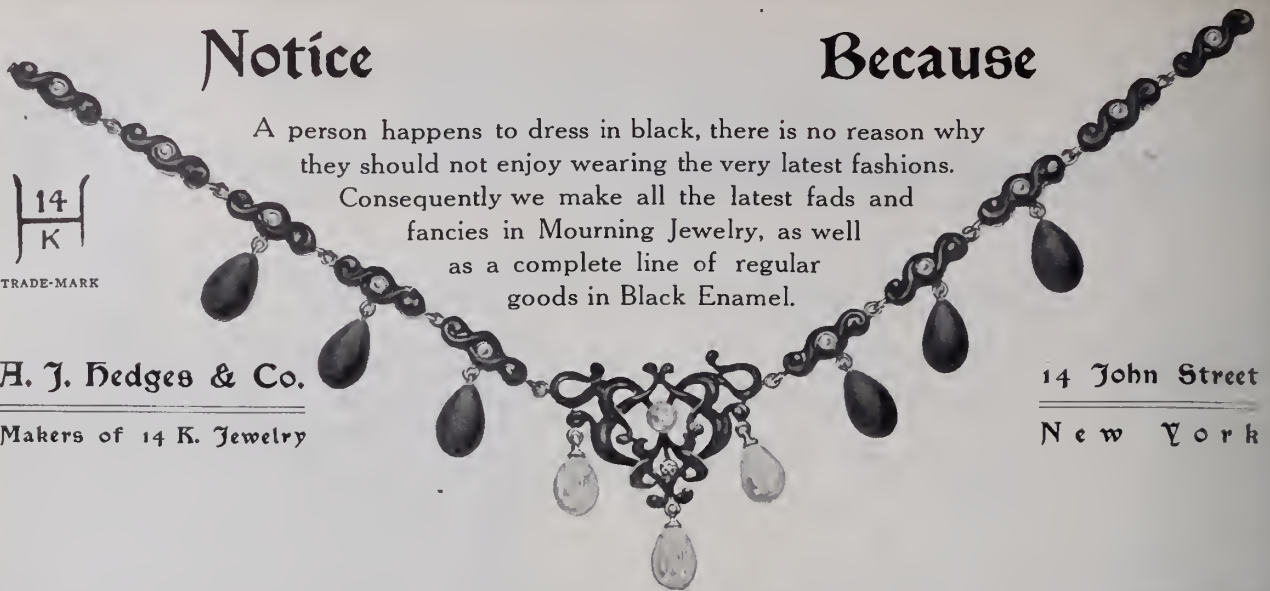

The Allsopp Rings

The Up-to-Date
Line of **Signet and Set Rings**



A ★
TRADE-MARK.

Allsopp

QUALITY,
DESIGN AND
WORKMANSHIP

Appeal to the Most Fastidious.
It Will Pay You to Examine
a Selection Package.



Allsopp Bros. Allsopp Building, Newark, N. J.

The Bowden Rings

ARE COMPLETE IN VARIETY, CORRECT IN
QUALITY AND PERFECT IN FINISH. WE
MAKE EVERY VARIETY OF FINGER RINGS.

J. B. BOWDEN & CO.,

1 Maiden Lane,

NEW YORK.

DIAMOND MOUNTINGS

of any description in gold and platina

Order Work a Specialty

HENRY BASCHKOPF

47-49 Maiden Lane

New York, N. Y.

GARREAU & GRISER
68 & 70 Nassau St., New York
LAPIDARIES. PRECIOUS
GEMS in Unique Cuttings

UNIQUE GEMS
SEMI-PRECIOUS CEYLON, URAL and NATIVE
GEMS My Specialty
Prices the Lowest. Sample Papers sent on Request
to Reliable Jewelers and Manufacturers.
Louis J. Deacon, Atlantic City, N. J.

The KREMENTZ MATCH BOX

made expressly for paper matches, in 14-Kt. Gold and Sterling Silver, with the following finishes:
Roman, polished, engraved, engine turned and the Krementz gun metal finish.

Open



Side View
Closed



Order No.
in 14-Kt. Gold
2117

Front View
Closed



Order No.
in
Sterling
Silver
2043

The side and front views show its compactness. It opens and closes easily and fits the vest pocket, taking very little space.

KREMENTZ & CO.

Manufacturers of

Fine Gold and Enamel Diamond Jewelry in 14-Kt. Only

MADE EXCLUSIVELY FOR FINE RETAIL JEWELRY TRADE

BRANCH
San Francisco Office
722 Shreve Bldg.

Factory and Main Office
NEWARK, N. J.

BRANCH
New York Office
1 Maiden Lane

THE ELEMENT OF CHARACTER IN FOBS



THE FOB, in its history and associations, is related to the signet ring. Both were the stamp and impress, the mark and signature of their owner. Great pains were taken to give them character. Durand Fobs are true to their traditional character.

PRICES: \$10.00 to \$220.00



DURAND & CO.

49-51 FRANKLIN STREET
NEWARK, N. J.



ENOS RICHARDSON & Co.

MANUFACTURERS OF

14-K GOLD JEWELRY



- | | |
|-----------------|------------|
| HANDY PINS | TIE CLASPS |
| SAFETY PINS | VEIL PINS |
| BROOCHES | HAT PINS |
| FLAT LINKS | SCARF PINS |
| DUMB-BELL LINKS | BARRETTES |
| FOBS | BELT PINS |

10-K AND 14-K NECK CHAINS AND GUARD CHAINS

PLAIN AND JEWELLED LORGNETTE CHAINS

23 MAIDEN LANE, NEW YORK



The R. S. Cigar Cutter

In Sterling Silver, Plain and Engraved; and 14 k. Gold, Plain and Engraved, also Set with Diamonds.

A Novelty

Unlike all other cigar cutters, this one lies flat in the pocket—does not get out of order.

A Good Article



We Push It

Our advertising makes the customer want it; his friend sees it and he wants it. An endless chain of customers.

A Good Seller



Trade supplied by

Enos Richardson & Co.

23 Maiden Lane, New York.

C. R. HOWE
W. T. CARTER
W. T. GOUGH

ESTABLISHED 1841 BY A. CARTER

F. R. HORTON
F. W. STANBROUGH
H. L. FARROW

CARTER, HOWE & CO.

MANUFACTURERS OF

GOLD JEWELRY

Bags and Purses in Gold and Silver

9-11-13 Maiden Lane, New York

Factory, Newark, New Jersey



SOLID GOLD CHAINS

bearing our trade mark stand for the highest achievement in gold chain manufacture. Plump quality, perfect workmanship, careful finish and attractive designs—all combined—distinguish our product.

WE SELL DIRECT TO YOU

No intermediaries, no corps of salesmen, no unnecessary expenses to add to the price—just the cost of the gold, the cost of making and a modest profit for ourselves enable you to buy the best chains at the lowest price. SEND FOR CATALOGUE.

ALOIS KOHN & CO.

16-18 MAIDEN LANE, NEW YORK

Gold Chains of Every Description



THEBERATH & CO., Inc.

Manufacturers of unusual, exclusive and salable designs in 14k. gold

**Brooches, Festoons, Handy Pins,
Barrettes, Pendants, Veil Pins,**

in beautiful plain patterns, or set with precious and semi-precious stones.

KENT & WOODLAND, SELLING AGENTS

12 John Street,

NEW YORK CITY



Steer Straight

for the Keller Line of Gold Jewelry during the year of 1908, and you will strike no breakers and will arrive safely at the end of a successful year of 1908.

THE KELLER JEWELRY MFG. CO.

Manufacturers of Fine Gold Jewelry

Brooches, Link Buttons, Locketts, Scarf Pins, Baby Pins, Handy Pins, Waist Sets, Crosses, Combs, Fobs, Tie Clasps, Charms, Lorgnette Chains, Neck Chains

64 NASSAU STREET, NEW YORK

Factory, 8 Lum Street

NEWARK, N. J.



SOLID GOLD COMBS

From \$1.50 Upward

A Snappy New Spring Line

in Plain and Engraved Bands, also

New Effects in Pierced Tops

14k.—Everything in Gold Jewelry—10k. Brooches, Barrettes, Buckles, Bracelets, Pendants, Festoons, Emblems, Hat Pins, Fobs, Scarfs, etc.



2 Maiden Lane,

New York

Hill & Schmidt

71 NASSAU STREET - - - - NEW YORK

Makers of Artistic 14 Kt. Jewelry



THE ARCHIBALD-KLEMENT LINE OF

SILVER DEPOSIT WHISKY BOTTLES

Distinguishable for their dignity of design and excellence of finish. Made in full quart size, four designs—Narrow Strap, Broad Strap, Rye, Thistle. Shield space for monogram, sterling silver cork-screw tops. Highball and whisky glasses to match each design.

No. 58

Full line of the foregoing, and any other desired pieces in the A-K Silver Deposit Ware, sent on approval.

ARCHIBALD - KLEMENT CO.
Sample Rooms: 341-347 Fifth Ave., N. Y.
Factory: NEWARK, N. J.



SNOW & WESTCOTT CO.

21 MAIDEN LANE, NEW YORK

JAMES P. SNOW

CHAS. E. WESTCOTT

Makers of Fine Gold Jewelry

ESTABLISHED 1834

J. H. GALAWAY F. H.

ENGRAVERS

CRESTS, MONOGRAMS and LETTERING

7 Maiden Lane, Rooms 44-45

Established over 35 years

Day, Clark & Co

Makers of 14-Kt. Jewelry

23 Maiden Lane
NEW YORK



I. N. LEVINSON, President

ESTABLISHED 1865

H. S. MORRIS, Sec. and Treas.

S. COTTLE COMPANY

Makers of High-Grade Gold, Silver, Gun Metal Novelties

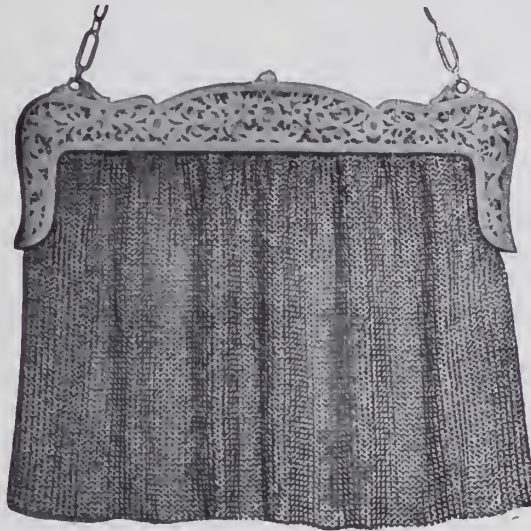

- Mesh Bags Buckles
- Card Cases Chatelaines
- Vanity Cases Sash Pins
- Purses Hat Pins

S. COTTLE CO.
31 EAST 17th STREET
NEW YORK

PARIS, 28 Rue D'Hauteville

"THE BRACELET HOUSE"

GOLD BRACELETS of every kind
For WOMAN, MISS OR BABY

KENT & WOODLAND

16 John Street, New York

Factory: Newark, N. J. San Francisco: Julius A. Young



Geo. O. Street & Sons

35 Maiden Lane, New York

Established 1837

- RINGS
- SLEEVE-LINKS
- SCARF-PINS
- FOBS AND SEALS

Grace for the Graceful

YOU WANT what your customers want—and every woman wants a Necklace. You want this Gold Bead line. Even and Graduated. Perfection of Vermicelli trim. Finest of Roman finish. Plain and decorated alternations. Fifteen sizes. It pays to carry them.



ACTUAL SIZE.
SEED-PEARL NECKLACES IN ALL SIZES.

OSMERS-DOUGHERTY CO.

MANUFACTURING JEWELERS

291-293 SEVENTH AVE., NEW YORK

Bet. 26th and 27th Sts. Telephone, 913 Madison.

DEALERS IN
BAROQUES, PEARLS and
FANCY STONES



DESIGNING
AND
SPECIAL ORDER WORK

“If It Is Chopard’s Idea, It’s Ideal”

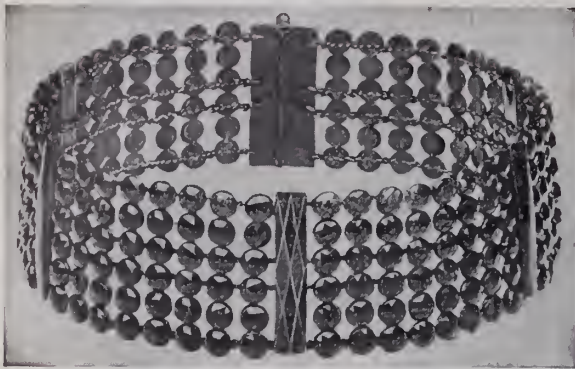

JETS continue to occupy the “Center of the Stage,” and no matter what you want, we can supply it.

Also **White Stone** and **Novelty Jewelry** of every description, and **Fish Skin Pearls** of unequalled lustre; all grades.

As we have said before, everything, direct from Paris, through us to you, at prices that insure you **BIG PROFIT** on **SMALL INVESTMENT**.

Selection Packages Sent Upon Request.

CHOPARD FRÈRES

Factory, 35 Rue des Trois Bornes,
PARIS, FRANCE

NEW YORK, OFFICE
56 Maiden Lane



327
FINE

Diamond Mountings
ALSO
Bracelets
AND
Dwt. Goods

S. PITZELE

Established 1893
51-53 Maiden Lane NEW YORK
Manufacture of



306

SPECIAL ATTENTION GIVEN TO ORDER WORK



688



325



329



218



435



348

Send for the Latest Styles in
MONOGRAMS AND INITIALS

as manufactured by
THOMAS J. DUNN CO.

101 Chambers St., New York
Makers of exclusive styles in
MONOGRAM FOBS

in Gold, Sterling and Rolled Gold Plate.
Our 1908 Ladies' Belt Buckles are most original and artistic.

Specialties in the Monogram and Initial line.
Send for Illustrated Sheets.



WE MANUFACTURE

Fancy Platforms and Blocks for Window Display.

Trays, for Show Cases and Travelers' Use, of every description.

Jewelry Boxes in many qualities and styles.

Boxes for Silverware, Manicure and Toilet Sets.

Silverware Chests in any combination.

Flannel Rolls and Bags for Silverware.

We Re-cover Window Platforms and Trays.

PAPER BOXES.

Tags, Cards, Cotton, Findings, Etc.
Estimates and Samples Cheerfully Furnished

WOLFSHEIM & SACHS

Office and Salesroom:
35 Maiden Lane,
(Lorsch Building)
NEW YORK
Factory: 10 Gold Street, N. Y.

THE GREAT AMERICAN JEWELRY CATALOG

Is a publication of real practical value; it truthfully illustrates those lines of merchandise; best adapted to the needs of the *Jewelry Trade*; its reliability is unquestionable.

SAFETY

With implicit confidence you can use it when ordering goods; it insures you against deception; remember, for every dollar's worth of merchandise you buy you are obtaining positive, intrinsic value.

Write for this catalog; it means much to you.

THE OSKAMP-NOLTING CO.

Manmoth Wholesale Jewelers
411-413-415-417 Elm St., CINCINNATI, OHIO



J. E. ROHRBECK
MANUFACTURER
40 FULTON ST.
NEW YORK, N. Y.

Orders Prove Our Goods Sell

Q We make for the Jobbing Trade the following lines of Solid Gold Jewelry:

Rings, Scarf Pins, Studs, Brooches, Charms, Baby Pins, Handy Pins, Chain Sets, Link Buttons, Hair Barrettes, Crosses, Ear Screws, Pierceless Drops, Cameos in all styles, etc.

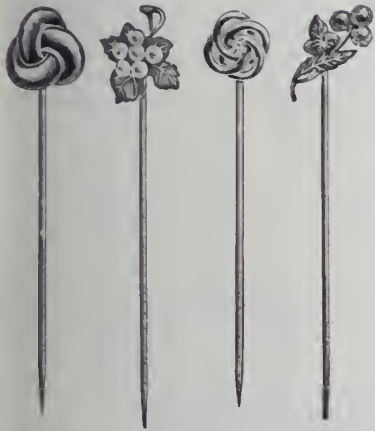

Insist upon seeing the designs of Gold Jewelry made by the

E. L. Spencer Company

95 CHESTNUT STREET
PROVIDENCE, R. I.

NEW YORK OFFICE
9-11-13 MAIDEN LANE

(SAMPLES ONLY)

P & B BABY PINS

BABY PINS—ALL DESIGNS
SUITABLE FOR BABIES OR GROWN-UPS

We are the Largest Exclusive Makers of 10 K. Jewelry.

Ask your jobber for the P. & B. Lines of Cuff Buttons, Crosses, Bead Necks, Tie Clasps, Brooches, Baby Pins, Scarf Pins, Bracelets, Locketts and Pins.

NEW YORK OFFICE, - - 65 NASSAU ST.

POTTER & BUFFINTON CO.

PROVIDENCE, R. I.

== BARRETTES ==

Plain
Fancy
Roman Pearl

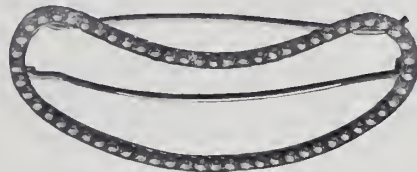

Hand Engraved
Pierced Effect
Set with Stones

ROMAN - ENGLISH - ROSE

The above cut shows one of our Roman Pearl 10 K. Beauties

Superior to Half Pearls — Will Not Discolor — May be Cleaned

Schultz & Co.
Makers of "Business Builders"



Factory and Office
91 Oliver Street - - - Newark, N. J.
New York Salesroom
12-14 John Street - - New York City

After July 1, 1908, this Company will change its name to

LAYMAN & STRAUS CO. Percy M. Layman Sydney C. Straus

Roger Williams Silver Co.,

PROVIDENCE, R. I.

Sterling Only.

RICH DESIGNS :: :: :: Photos. on Application.

LOCKETS ONLY

S. F. Myers & Co.

WHOLESALE JEWELERS
47-49 Maiden Lane
New York

Molasses catches more flies than vinegar.
Our bait is all molasses.

For the trade only—our
new, big catalogue, with
100,000 items, sent free.

Registered



U. S. Pat. Office



Pat. Applied for
NUMBER
8482

Latest Design Appropriate for Easter

WIGHTMAN & HOUGH CO.

NEW YORK OFFICE
3 Maiden Lane

Main Office and Factory } 7 Beverly St.
PROVIDENCE, R. I.



SHUROлда



Automatic Scarf Pin Protector



14 Kt. Gold Plate

Price 50 Cents

To Release Pull the Ball

To Release Pull the Ball

Pat. Mar. 12, 1907. No. 847,164. The Stronger the Pull the Firmer It Holds Pat. Mar. 12, 1907. No. 847,164.

Samples and Prices on Application

FOR SALE BY JOBBERS OR DIRECT BY

STERN & CORN, 71-73 Nassau St., NEW YORK

WM. SMITH & CO.

OFFICE: Established 1854.

MANUFACTORY:

9-13 Maiden Lane, New York

61 Peck St., Providence, R. I.

Manufacturers of GOLD AND SILVER CHAINS
GOLD, SILVER AND PLATED CHAIN TRIMMINGS

Also GOLD AND SILVER
KEY CHAINS AND
BRACELETS

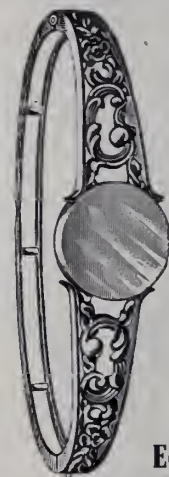

10K. GOLD BRACELETS

New and Original
— Designs in —

BANGLE, JOINT
— AND —
CATCH SIZES

Scarf Pins, Ladies' Rings
Earrings and Handy Pins

In a great variety
of designs

TRADE MARK

THE

Edwin Lowe & Co., Inc.
F. W. BODWELL, Pres. & Gen. Mgr.

116 Chestnut St., PROVIDENCE, R. I.

New York Representative: Western Representative:
E. T. Wilson, 180 Bway. S. H. Brower



Monograms

INITIALS
AND
FOBS

Our
Specialties

Write for Catalogue
Prices and Discounts

CHICAGO
ART METAL
WORKS

63 Lake Street,
CHICAGO, ILL.

CASTINGS Gold, Silver, Bronze, Brass, German Silver, Copper and Iron.

L. D. TEL. 2072 L. Supply Jewelers, Silversmiths,
Die-makers, Mould-makers, etc. Bronze Forces, Hard
Bronze and Iron Shells for Die-cutting Machines.
Cast Iron Hub for sinking in Steel Dies. Chandelier,
Undercut Work, Statuary.

AUGUST GRIFFOUL 313 HALSEY STREET
NEWARK, N. J.

Perennially Popular

THE best evidence of the popularity of our various lines is the increasing demand for them and our consequent growth. Our jewelry is unexcelled in every quality that contributes to serviceability and appearance. The designs are artistic enough to court that investigation which results in sales.



No. 1117

Ask to see our line of

**CHAINS
CHAIN PENDANTS
CROSSES
AND BRACELETS**

The
Kenilworth Bracelet

particularly, the strongest on the market.

**DORAN,
BAGNALL & CO.**

North Attleboro, Mass.

OFFICES

New York: 194 Broadway.
Chicago: 42 E. Madison St.
San Francisco: 91 Drumm St.



No. 4397 X 1

CROUCH & FITZGERALD

Jewelry Trunks and Cases

177 Broadway,
Bet. Cortlandt and Dey Sts.
688 Broadway,
723 6th Ave.,
New York.



Try Wells' Perfect Ring Adjusters

1 doz. asst. sizes 10k gold filled (gold on front twice as thick as on back), \$2.00.
1 doz. asst. sizes solid 10k gold, \$3.75.
1 doz. asst. sizes, metal, 85c. Ask your jobber for them, or I will send, prepaid, at once (only on receipt of price), two samples—one small and one medium large gold filled and one metal adjuster for 50c. Address



CHESTER H. WELLS, Jeweler, Meshoppen, Pa.

THE CROWN PATENT SAFETY GUARD



For Scarf Pins Studs and Lace Pins. The most practical and only adjustable one invented. Price, \$1.50 per doz. For sale by all wholesale jewelers and material houses. Sample by mail, 25c.; in 10k gold, \$1.00; 14k., \$1.25. M. CROHN, Maker and inventor, 48 and 50 Maiden Lane, N. Y.

Rosaries Sell Well !!

GOLD FILLED SEAMLESS WIRE. Guaranteed to Wear. Im. Amethyst, Emerald, Ruby, Garnet, Aqua Marine, Sapphire, Mother of Pearl, Agate, etc., etc.



607E

665E—Fine rolled plate rosary, real mother of pearl beads with crucifix; an excellent seller. It will pay the up-to-date jeweler to handle rosaries.

We furnish these rosaries with imitation amethyst, emerald, garnet, light topaz (or amber) at the same price. Order an assortment of colors. List price \$2.50 each.



607E

607E—Emerald, oval shaped bead rosary. We carry these rosaries in stock in imitation amethyst, garnet, emerald, crystal, light topaz (or amber).

Send in your order. You will find them sellers, \$4.00 each, list price.



665E

664E—Fine rolled plate rosary, real Mother of Pearl beads with crucifix; an excellent seller. It will pay the up-to-date jeweler to handle rosaries.

We furnish these rosaries with imitation amethyst, emerald, garnet, light topaz (or amber) at the same price. Order an assortment of colors. \$2.25 each, list price.

A large line of Easter Goods on Attractive Cards. Call and see them!

M. J. AVERBECK, 10-12 Maiden Lane
NEW YORK

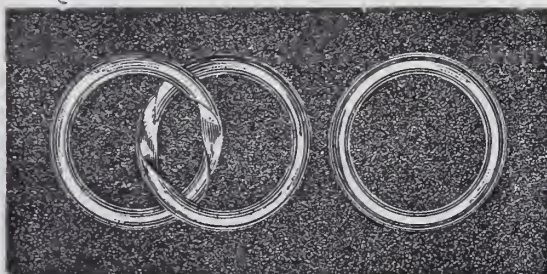

WE MAKE

The Alliance Ring

The graceful style of the Alliance Ring is rapidly supplanting the use of the old style wedding ring. The joints are invisible, and whenever engraving is desired it is done in the inside surface. Can be easily separated by inserting a pin in inside pin hole.

14 karat, 3 dwts., each, \$1.25 per dwt. ; in dozen lots, \$1.15 per dwt., net.
18 karat, 3 dwts., \$1.40 per dwt. ; in dozen lots, \$1.30 per dwt., net.

MADE ONLY BY

LEONARD KROWER, Manufacturing Jeweler

536-538 Canal Street

New Orleans, La.



EASTER OFFERING

THE MOST
COMPLETE PROTECTION
LIFETIME SATISFACTION

VERIBEST



LOCKETS

It's the Quality Gold that
we use that makes them
"Goodasgold"

"Lederermak"

Exclusively sold by

VERIBEST



Jobbers Everywhere

Manufactured and Guaranteed by

S. & B. L. CO.

New York City, 9-11-13 Maiden Lane
Providence, R. I., 100 Stewart Street
Chicago, Ill., 131 Wabash Avenue

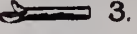

-  1. Snap complete.
-  2. Outside of snap.
-  3. Inside of snap.

**The E. P. H. Patent
NON-PULL-OUT
Neck Chain Snap**

*is a patented snap that insures
the wearer against loss of*

CHAIN or CHARM

for it positively will not pull out

**Made in 10 and 14 Karat Gold and
in Gold Filled.**

*Can be had of the following Whole-
sale Selling Agents:*

Messrs. W. Green & Co.,
81 Nassau St., New York

- M. Sickles & Sons, Philadelphia
- E. A. Cowan & Co., Boston
- E. & J. Swigart, Cincinnati
- Swartchild & Co., Chicago
- Nordman Brothers, San Francisco
- Leonard Krower, New Orleans
- A. Walker Co., Providence, R. I.
- Bauman-Massa Jewelry Co., St. Louis
- H. S. Meiskey Co., Lancaster, Pa.
- The Edw. Lehman Jewelry Co., Denver, Col.

PRICES.

- 14 Karat—Small, \$7 per doz. net
- Large, \$7.50 per doz. net
- 10 Karat—Small, \$6 per doz. net
- Large, \$6.50 per doz. net
- Gold Filled—Small, \$2 per doz. net
- Large, \$2.25 per doz. net

EVERYTHING IN LOCKETS AND CHAINS.

THE BASSETT JEWELRY CO.,

PROVIDENCE, R. I.



Charles Wagenführ
Die Sinker,
140 West Broadway,
New York.

Trade-Marks of the Jewelry
and Kindred
Trades. Second Edition. Price, \$3.00.
The Jewelers' Circular Publishing Co.



CAMEOS

Stone, Shell, Coral and Lava.
Rolled Gold Plate Mountings

SELECTIONS SENT TO
RELIABLE JOBBERS

Maintien Brothers & Elliot
North Attleboro, Mass.

O. M. DRAPER CHAINS

ALL KINDS OF VEST CHAINS
PRINCESS, NECK AND GUARD CHAINS

We do not make as much noise as some of our friends but we are "there with the goods" and the *Jobbing Trade* handling our product for the last half century, know that our QUALITIES are genuine and can be depended upon, that our FINISH is unparalleled and that our prices are consistent.

If you do not handle O. M. DRAPER GOODS, we both lose.
We sell only to the Jobbing Trade.

Estate of O. M. DRAPER

Factory, No. Attleboro, Mass.

NEW YORK OFFICE
37 Maiden Lane

SAN FRANCISCO
506 Chronicle Building

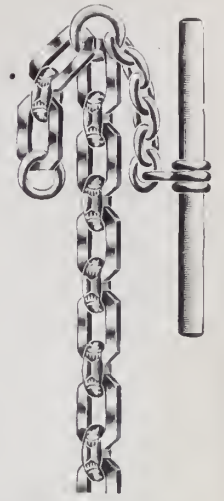
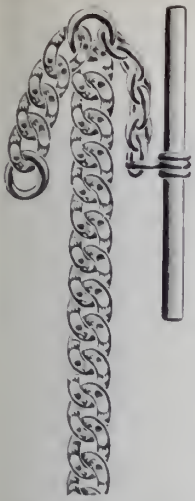

The Simplicity Collar Supporter

A practical and ornamental novelty. Only one pin to fasten. The stiff bar acts as a support to the Gibson collars now so extensively worn, and conceals the two ends where they come together. All sizes. Neat and convenient. Look for our trade mark and accept no others. **BIG SELLERS.**



VEIL, CUFF AND BABY PINS, CAMEOS

SWASTIKA Buckles, Bracelets, Buttons, Charms, Brooches, Barrettes, Combs, Hat Pins, Scarf Pins, Leather Trimmings.



MILLER, FULLER & WHITING CO.
MANUFACTURING JEWELERS

NORTH ATTLEBORO, MASS.
New York Office Samples We Sell to the
9-11 Maiden Lane only. Jobbing Trade Only

THE WASHBURN

SECURITY **MAGIC NUT**
Automatic Holder for ear studs, scarf-pins etc.
for all sizes of scarf-pin wire. Guaranteed.

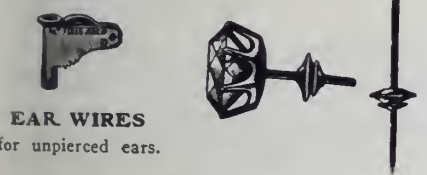

EAR WIRES
for unpierced ears.

SAFETY CATCH
For Brooches, etc.
Can be applied to any work where pin tongues are used.

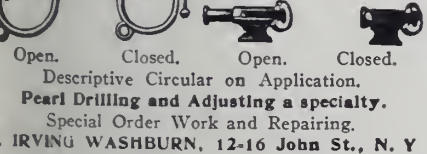

Descriptive Circular on Application.
Pearl Drilling and Adjusting a specialty.
Special Order Work and Repairing.
C. IRVING WASHBURN, 12-16 John St., N. Y

The Thimble House.



No. 149.

Thimbles are not a side line with us—They are our main business. We study Thimbles, our designers study thimbles, our workmen study thimbles—The result is the finest and largest line of Thimbles on the Market.



No. 136.

KETCHAM & McDOUGALL,

Manufacturers,

37 @ 39 Maiden Lane, New York.

Send for Catalogue.

Established 1832.

ALSO MAKERS OF THE NEW AUTOMATIC EYE-GLASS HOLDERS.

Machine cut work a specialty

- DIES -

Designs cheerfully submitted for jewelry, silverware, medals, emblems, brass goods, etc.

We are using the most approved and modern reducing machines, guaranteeing the finest work.

- DIES -

Crees & Court, Die Sinkers

21 EDDY STREET, PROVIDENCE, R. I.

- DIES -

WRITE TO-DAY FOR A SELECTION



The "SECURITY" Necklace Clasp

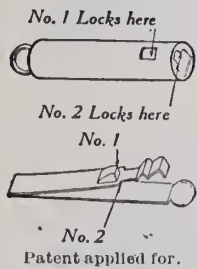

HEAR IT SNAP
Absolutely Secure and Simple. Cannot Pull Out
LOCKS IN TWO PLACES

Making it Doubly Secure
The Only Perfect Clasp

Ask Your Jobber or Write.

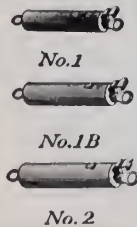

Patent applied for.

PRICES TO THE TRADE:			
No. 1.	10-Karat,	- -	\$6.00 doz.
" 1-B.	10 "	- -	7.00 "
" 1.	14 "	- -	7.00 "
" 1-B.	14 "	- -	9.00 "
" 2.	10 "	- -	9.00 "
" 1.	Platinum,	- -	18.00 "
" 1.	Gold Filled,	- -	2.00 "
" 1-B.	" "	- -	2.25 "
" 2	" "	- -	2.50 "
" 1.	Sterling Silver,	- -	2.00 "

The Hoffman Novelty Co.,

"CLINCH"



Safety Catch for Scarf Pins

Does not mar the pin. Nothing to get out of order. Simple and neat.

One turn to the right grips like a vise.

..FITS ANY SIZE PIN..

Patent applied for.

PRICES TO THE TRADE

No. 1 Gold Plated	\$1.50 doz.
No. 2 Roman Gold	2.00 doz.
No. 2 14k G'ld Pt'	2.25 doz.

No. 1, 25c.

Makers, 79-83 No. Pearl St., ALBANY, N. Y.

The **St. James**

Cor. Walnut and 13th Sts., Phila., Pa.

THE IDEAL HOTEL OF THE QUAKER CITY

A spacious fire and burglar proof safe has been provided for the convenience of the trade. Palatial rooms with bath \$2.50 per day and up. Rooms without bath, (running water) \$2.00 and up.

EUGENE G. MILLER, Mgr.



The Gillette Safety Razor Set consists of a triple silver-plated holder and twelve double edged, thin, flexible, wafer-like blades (24 keen edges), packed in a velvet lined leather case. Price, \$5.00. Also made in Combination Sets in a variety of styles with toilet accessories retailing from \$6.50 to \$50.00 each.

Would You Have the Present Year Bring You Increased Patronage, Profit and Prosperity?

Do you realize that nearly every hour in the day some man is converted to the easier, quicker and more economical way of shaving himself with the

Gillette Safety Razor?

Our persistent and vigorous advertising in the leading publications of this country discloses — *and will continue to disclose* — beyond all question of doubt, the superiority of the "Gillette." It advocates the advantages of self-shaving and guides the man to your store with a five dollar bill to exchange for the best shaving device in this world.

You can readily see the wisdom of having the "Gillette" ready when he calls. The Standard Gillette Set retails at \$5.00 everywhere. Combination Sets from \$6.50 to \$50.00. Keep a good supply in stock. Write to-day for valuable selling information and prices.

GILLETTE SALES CO., 904 Times Bldg., New York City



Scarf Pin 891
Old English
Set as ordered

Scarf Pin
842—Rose
or Green
Set as
ordered

Neck Chain 296
Old English Chain
Roman Scrolls
16" long
Stones set as ordered
Baroque Pearl
Pendant

Link Button
877—Rose, Ruby
and Brilliants
878—O.E., Ruby
and Brilliants

Link Button
872—O.E., Stones set
as ordered

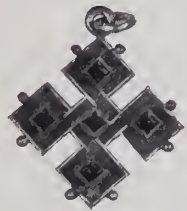

Charm 2982
Rose, Ruby Stones

Easter Suggestions

We have this season many choice designs in Fine Gold Filled Jewelry, suitable for Easter gifts, among which are Neck Chains and Pendants, Locket and Charms, Link Buttons and Bracelets, as well as Brooch, Veil, Scarf and Hat Pins. Our Gold Filled Goods meet the most critical test for high standing.

We mention our Sterling Silver Toilet, Manicure and Table Goods as appropriate Wedding Gifts.

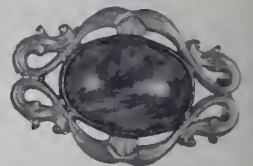

Brooch Pin
3864—Old English, Japanese
Jade Stone



Locket
3013—Rose, No Stones
3016—Rose, Red Eyes,
White Mouth



Scarf Pin
884—O.E.
Set as
ordered



Belt Buckle
3540²—Rose, Ruby Eyes, Stone in Mouth set as ordered, Pin Stem
3540 —Rose, Ruby Eyes, Stone in Mouth set as ordered, Clasp

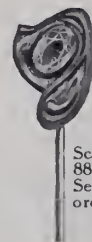

Scarf Pin
886—O.E.
Set as
ordered



Charm
2984—Rose, Red Eyes,
White Mouth
2983—Rose, No Stone

Theodore W. Foster & Bro. Co.

Manufacturing Jewelers and Silversmiths

100 RICHMOND ST., PROVIDENCE, R. I.

NEW YORK: 13 Maiden Lane

CHICAGO: Heyworth Bldg.

CANADA: Kingston, Ontario

THE JEWELERS' CIRCULAR

WITH WHICH ARE CONSOLIDATED
THE HOROLOGICAL REVIEW
THE JEWELERS' WEEKLY **THE JEWELERS REVIEW**

Vol. LVI. WEDNESDAY, MARCH 18, 1908. No. 7.

Commerce of the Philippine Islands, in Watches, Clocks, Jewelry, Etc.

WASHINGTON, D. C., March 12.—The latest commercial returns for the Philippines show that business is gradually recovering from the depression to which it has been subjected, and Secretary Taft expresses the opinion that during the next 25 years a development will take place in the islands which will be as remarkable as the development of Alaska during the past 10 or 15 years.

Reviewing the trade for the quarter ending Sept. 30 last, we find that the importations of clocks and watches are larger than they were for the corresponding three months in 1906, the value for that period being \$3,096 and for the past year \$3,428. This is not borne out, however, in the returns for the nine months, in which there has been a steady decline shown during the past three years, the value for the first nine months of 1905 being \$9,738, for 1906 \$8,938, and for the past nine months only \$8,180. Returning to the importations for the quarter, we find that Germany has superseded us in first place with a value of \$1,113 as against \$701 for the corresponding three months in 1906; on the other hand, we have fallen from first to second place with a value reduced from \$1,176 to \$688. A new competitor—Austria-Hungary—stands third for the first three months with a value of \$617, and thus takes the place formerly held by Japan, who shows a decreased value from \$851 to \$614. The other contributors are France, \$263; China, \$63; United Kingdom, \$60; Belgium, \$9, and Italy, \$1.

The importations of watches for the first nine months of last year show a decided falling off. In 1905 the value of these importations for the first nine months was \$60,516; in 1906 it had fallen to \$44,673, and still further during the nine months of last year to \$20,308. For the three months ending with Sept. 30 the value was only \$5,450, as compared with \$6,614 in the corresponding three months of 1906. France still stands first as the source of supply, although with a value reduced from \$3,298 to \$5,450; on the other hand, the United States stands second with a value slightly increased from \$1,456 to \$1,778. Germany shows an increase from \$44 to \$194; Switzerland shows a value reduced from \$1,794 to \$822, and Japan from \$16 to \$12; on the other hand, Italy has a value of \$138, and was not a factor in the corresponding three months of 1906.

In the jewelry trade the decline is even more marked than in the clock and watch importations. Taking the importations for the first nine months of last year, we find that there has been a decrease in value from \$1,387 to \$16,815, and that for the three months there has been a decrease from

National Monthly Import and Export Statistics.

WASHINGTON, D. C., March 11.—The records of the Treasury Department contain the following comparative statistics of interest to the jewelry trade, for January, 1907 and 1908, and for the seven months ended January, 1908:

	IMPORTS.		—7 Months Ending—	
	Jan., 1907.	Jan., 1908.	Jan., 1907.	Jan., 1908.
Clocks and parts of.....	\$43,886	\$22,986	\$428,178	\$378,831
Watches, materials and movements.....	224,593	171,946	1,842,419	1,728,464
Diamonds, glaziers' diamonds, etc., unset, and watch jewels (free).....	834,146	74,393	6,900,693	3,727,066
Diamonds, n. c. s., not set (dutiable).....	1,824,653	176,452	14,821,714	8,159,674
Diamond dust or bort (free).....	14,761	5,150	62,560	45,803
Precious stones, rough or uncut (free).....	22,197	32,071	80,842	86,754
Precious stones and pearls, not set (dutiable).....	576,177	128,511	4,814,146	2,118,872
Jewelry and manufactures of gold and silver.....	132,252	1,121,073
EXPORTS OF FOREIGN MERCHANDISE.				
Clocks and parts.....	\$30	\$359	\$588	\$871
Watches, materials and movements.....	124	4,406	1,976
Diamonds, rough, including miners', glaziers', etc.....	9	2,349
Diamonds, n. c. s. (dutiable).....	15,277	30,718
Precious stones and pearls, not set (dutiable).....	10,585	1,968	17,546
Jewelry and manufactures of gold and silver.....	4,343	13	20,212	5,912
EXPORTS OF DOMESTIC MERCHANDISE.				
Clocks and parts.....	\$108,242	\$109,378	\$832,931	\$898,234
Watches and parts.....	103,014	72,961	1,081,424	916,028
Jewelry and manufactures of gold and silver.....	167,226	108,706	1,219,541	1,062,193
Plated ware.....	37,047	43,204	487,954	500,861

\$15,409 to \$6,751. France has taken first place as a source of supply, although with importations reduced for the three months from \$4,582 to \$4,333 the United States has jumped from third to second place, although it is with a value reduced from \$4,277 to \$1,548, while Germany has fallen from first to third place with a value reduced from \$5,507 to \$490; the United Kingdom, Spain and Italy have dropped out; China shows a slight increase from \$139 to \$166, Hong Kong from \$27 to \$154, Japan from \$28 to \$102, and the British East Indies from \$10 to \$48.

Of all other manufactures of gold and silver there has also been a decreased import value for the nine months. For the three months there has been an increase from \$4,274 to \$8,944. The main part of this increase is in importations received from the United States, in which the jump has been from \$1,694 to \$5,788; the United Kingdom stands second with an increase from \$41 to \$945, Germany shows a decrease from \$294 to \$123, and France from \$1,285 to \$670. Austria-Hungary is a new competitor, with a value of \$57; China shows an increase from \$32 to \$841, Hong Kong a decrease from \$114 to \$52, Japan an increase from \$346 to \$452, while the British East Indies shows a decrease from \$62 to \$16.

About the only item in which there is to be noted a satisfactory increase is plated ware, and in that we find that the manufacturers of the United States are allowing those of other countries to walk away with a trade in which they had a strong lead. For the nine months of last year the value of the importations of plated ware was

\$36,592, as against \$14,534 in 1906. But while the United States increased her share of the trade from \$6,997 to \$11,542, she has fallen from first to second place by allowing France to lead with a value of \$13,566 as against \$3,015 last year.

During the three months France stands first with a value of \$5,084 as against \$1,968 in 1906, Germany stands second with a value of \$4,168 as against \$1,000, and the United States third with a value of \$4,005, as compared with \$2,766 in the corresponding three months of 1906. Other sources of supply were as follows: United Kingdom, \$696; Japan, \$875; Austria-Hungary, \$202; British East Indies, \$67; Italy, \$47; China, \$37; Switzerland, \$31; Spain, \$29; Belgium and Australia, each \$4, and Hong Kong, \$3.

The exports show largely increased exportations of mother-of-pearl from \$15,373 to \$19,027, all of which was exported to the British East Indies; the exportations of tortoise-shell show an increase during the three months of \$4,316 to \$5,818; on the other hand, of all other shell there is a decrease in the export value from \$16,571 to \$11,201.

Evidently the prophesied prosperity that is coming to the islands will be needed before there is any very satisfactory opening for anything but the necessities of life.

Samuel W. Fellows, Lawrence, Mass., was recently swindled out of two valuable rings by a stranger, who entered his store ostensibly to make a purchase. The thief cleverly substituted two worthless rings for those which he stole. Thus far no arrests have been made.

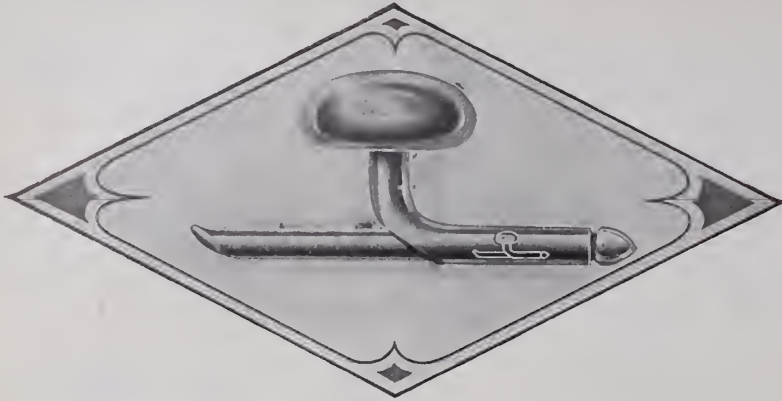

THE COAT SHIRT

is coming more into use each year. If you are a progressive retail jeweler, why not have in stock a line of Shirt Studs that not only can be used in the coat shirt, but also in any other style shirt made?

The Larter Shirt Stud fills all requirements and has our guarantee stamped on the barrel of each in the form of a Trade-Mark that there is no better shirt stud made.

Over 500 patterns in 18K. and 14K. gold and 10K. gold and 14K. gold filled. These last two lines to be had through progressive jobbers.

LARTER & SONS

21-23 Maiden Lane, New York, N. Y.

TRADE-MARK



REGISTERED IN U. S. PATENT OFFICE

ELSIE BEE'S FASHIONS.

SPRING NOVELTIES NOTED IN A LADY'S RAMBLES
AMONG THE JEWELERS.

CORAL in button effect is used on festoon necklaces, the coral being relieved by baroque pearls.

* * *

Among stones, Chinese jade has a place in the front ranks. Its color is adapted to many applications.

* * *

The best selling veil pin is conceded to be the slightly curved bar, plain or engraved. It is the simplest of the standard styles.

* * *

The new designs in black bracelets are most attractive. One very striking but simple design consists of a heavy dull black band, well rounded and in bangle form, set with three medium-sized round pearls.

* * *

A dainty design has for a central setting a close row of small half pearls, on either side of which is a narrow twisted strip of black. This is finished with a black wire. A perfectly round dull black bangle is set with small diamonds, about one inch apart.

* * *

After a little lull, coral is coming forward. It is seen in carved rose designs with enameled leaves and polished wire stems. In this form it is applied to La Vallières—sometimes three pendants of differing sizes hanging from a simple gold chain—brooches of all sizes, and handy pins.

* * *

Sporting veil pins constitute a somewhat new class. To get the length that is an essential feature of the veil pin, this is a satisfactory design—the crop and horseshoe nails admitting of a certain lengthening out that is desirable. In this new assortment the horseshoes are somewhat irregular in shape and the curl of the whips has some original turns and settings.

* * *

A distinct novelty in men's scarf pins is just appearing. It has grown out of the demand for a variety of pins, each harmonizing with certain ties or suits, and it stands as an inexpensive solution of this question. Formerly a man was content with a single pin as with one pair of cuff links, but fashion is now more exacting, and he who considers himself smart must be provided with many of these articles or his wardrobe is not complete. The new pin is made with two finished sides, either of which may be worn outward. Now, there are several inner sections attached only at the top and bottom and capable of being turned completely around. This makes it possible to have a number of designs—seven different combinations in all. The least expensive of this new style is constructed half of gold and half of platinum. This makes the designs simply a various combination of these two materials, but the contrasting colors give the effect of distinctive and separate scarf pins. This hardly seems possible until one has seen the pins.

ELSIE BEE

Some Notable Reproductions of Ancient Irish Jewelry and Silverware Put on Exhibition.

AMONG the recent accessions at the Metropolitan Museum of Art, New York, is a collection of reproductions of Irish jewelry, illustrations of which are shown herewith, which is attracting no small amount of attention. The illustration on the front cover of this issue shows a collection of reproductions of early brooches, among which is the Kilkenny brooch, the original of which was found in

been added to the collection of reproductions copies of objects in the National Museum and Trinity College, Dublin, with a few from those in private collections. First in importance among the originals from which these copies are taken are the shrines containing a bell, book, crozier, or relic—usually of bronze, set with gold, silver, jewels, etc. The shrine of Lough Erne, an example of the 'Church-shaped' form.



LISMORE CROZIER.

CLONMACNOISE CROZIER.

Saint Carthagh, the first Bishop of Lismore, the niche having been made for its protection. One of the most beautiful of croziers is that of the Abbots of the great monastic city of Clonmacnoise on the Shannon, dating from about the year 1100, now in the



THE TARA BROOCH.

National Museum. It is decorated with silver strips let into bronze, and has an unusually fine openwork 'mane' along the edge of the curve and head. It was discovered about 1790 in the little church of Kiernan, the reputed burial place of Saint Kiernan.

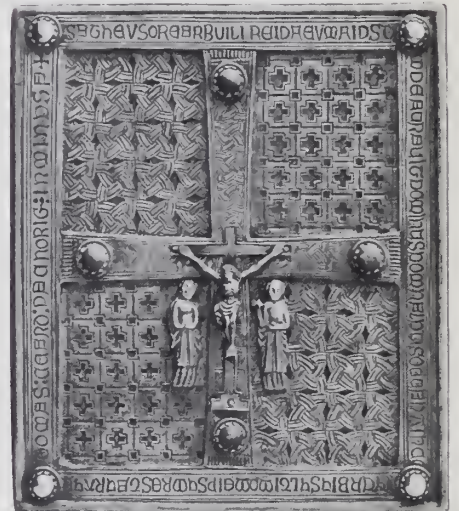

SHRINE OF THE BOOK OF DIMMA.

the County Kilkenny. The spectacle brooch was found near Meath, Slane County. The original university brooch is in Trinity College, Dublin.

In speaking of this collection of reproductions the *Bulletin* of the museum says:

"In the artistic handicrafts and manufactures, Ireland has held a proud position, especially as regards silver and glass, the examples exhibited at the Historical Loan Collection of the Irish International Exhibition, held at Dublin during the past year, showing how well deserved was this pre-eminence.

"A few reproductions placed in the museum a year ago show the great skill of the craftsman in these materials down to the end of the 12th century. There have now

fished out of Lough Erne in 1891, contains a smaller and older shrine with a yew box. It is evidently of a date earlier than 1100 A. D. The shrine of the Book of Dimma, now at Trinity College, was found in 1789 among the rocks of the Devil's Bit Mountains, Tipperary, and was made in the year 1150 to contain a copy of the Gospels written by Dimma, the scribe, some time in the seventh century.

"The Lismore Crozier, or Pastoral Staff of MacMeic Aeducan, a former Bishop of Lismore, who died in 1120, was found, together with the celebrated book of Lismore, built into a recess in a wall when Lismore Castle was restored about 1811. It is now in the possession of the Duke of Devonshire and is probably the actual pastoral staff of

"The celebrated Charter-horn, symbol of the conveyance or transfer of property, usually known as the 'Kavanagh Horn,' was presented to Trinity College by Thomas Kavanagh of Ballyborris in the County of Carlow, a lineal descendant of the last King

LOUIS KAHN

MOSES KAHN

SAMUEL H. LEVY

L. & M. Kahn & Co.

Importers and Cutters of
DIAMONDS

170 Broadway, cor. Maiden Lane, New York

AMSTERDAM: 2 TULP STRAAT

CUTTING WORKS: 29 GOLD STREET

Arnstein Bros. & Co.

Importers and Cutters of

DIAMONDS

65 Nassau Street

New York

LONDON: Audrey House, Ely Place

AMSTERDAM: 6 Tulp Straat

ALBERT LORSCH

N. Y. Telephone Call, 2161-2 John

ALFRED KROWER

ALBERT LORSCH & CO.

LORSCH BUILDING, 37 and 39 MAIDEN LANE, NEW YORK

131 Washington Street, Providence, R.I.

Reconstructed Rubies

IN CABOCHON AND BRILLIANT CUT, ALL SIZES AND SHAPES

of Leinster. Carved out of ivory, it is 16-sided and stands upon a pair of brass legs with gilded brass body-mounts, and bears the inscription, *Tigernanus O'Lavan Me Fecit Deo Gratias I. H. S.*, which gives the name of the craftsman, Tiernan O'Lavan.

"Of the objects of personal adornment used in Ireland, the principal and commonest was the brooch of bronze, rarely of the precious metals, enameled or jeweled, which was worn both by men and women. The earliest are those which had a movable ring, usually with expanded ends, and with a slit by which the open ring could be passed under the pin and turned so as to hold it firmly in place. A second stage in their development displays brooches with larger flattened ends, sometimes triangular in shape. Still later is the type in which the slit of the ring is closed by a small band or tongue of metal, and can, therefore, no longer be turned under the pin. In the last stage the slit has been completely closed, although clearly indicated in the pattern. The ring pins were developed from the brooches and probably came into use about the ninth or 10th century.

"The Tara brooch, a reproduction of which is already in the museum, is the most perfect of those now preserved at Dublin. The so-called Dalriada brooch is of fine gold, in which it is probably unique, and, according to Dr. Petrie, is not later than the end of the 11th or beginning of the 12th century. The recent accessions include copies of several other famous brooches: the brooch found at Kilmainham, County Dublin, where once stood a hospital of the Order of Templars; the Cavan (or Queen's); Kilkenny and Tipperary brooches, called after the counties in which they were found, all in the National Museum; the University brooch in Trinity College, with

ornament formed of the interlacing of the bodies of the Irish Elk; the Clarendon, or Ogham brooch, the only one found bearing an inscription in the Ogham character; and the Arbutus brooch, deriving its name from

seum of Trinity College, are shown; also copies of two methers or drinking vessels in wood."

In speaking of the Tara brooch, Nelson Dawson, in a book entitled "Goldsmiths and

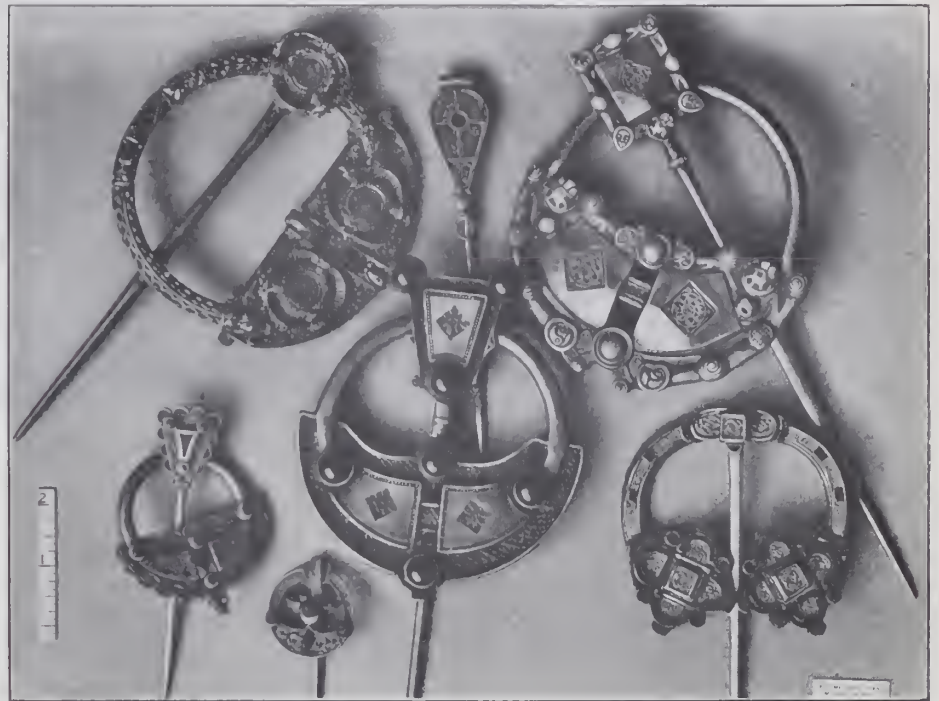

BROOCHES FROM KILKENNY, ROSCREA, TIPPERARY AND OTHER LOCALITIES.

its resemblance to the decoration of the berries of that tree.

"Reproductions of cloak and bodkin pins, earrings, neckrings, a large fibula of fine gold weighing 33 ounces, now in the Mu-

Silversmiths' Work," says: "The original Tara brooch is made of whitish looking metal that suggests silver, referred to as white bronze, namely, copper with a large admixture of tin, with possibly some silver. These are delicate enrichments of gold and silver ware work cleverly attached to the surface, some of which are of so intricate and minute a pattern that they can hardly be seen with the naked eye."

Referring to Irish jewelry the same author says: "There is naturally more known about the metal work of the Christian period than about that of the previous era. St. Patrick came to Ireland about 440, and he had a large following of ecclesiastics and others, mostly foreigners, in his train. Among these were the Smiths, MacCeicht, Laebhan and Fontchar and three other skilled artificers, Aesbuite, Fairill and Tassach, and it is on record how the former were ordered to make bells which were left in all parts of Ireland in the oratories established by St. Patrick, while the braziers had to make the patens and the ministers the altar chalices."

Morris Nobbe gave an oyster dinner Washington's Birthday at the Club House, five miles from Galveston, Tex. Among the guests were: A. C. Winters, of Enos Richardson & Co.; Alex. I. Mayer, of Arnstein Bros., and Jake Zineman, of Heyman & Kramer. Mr. Nobbe, attired as George Washington, delivered a short address on the "Father of His Country." Mr. Winters gave several vocal selections and Mr. Meyer acted very cleverly as an imitator as well as giving several piano selections, while Mr. Zineman danced.



LOUGH ERNE SHRINE.

EDUARD VAN DAM

CUTTER OF

DIAMONDS

CUTTING SHOPS:

ANTWERP

41 Rue de la Province (Sud.)

CABLE ADDRESS, MADNAV

NEW YORK

437-439 Fifth Ave.
Cor. 39th St. Knabe Bldg.

TELEPHONE, 5879 38TH ST.
CABLE ADDRESS DEVRIVAN

AMSTERDAM

55 Ruysdaelstraat

CABLE ADDRESS, MADNAV

LONDON OFFICE, 22 Holborn Viaduct

AMSTERDAM

2 Tulpstraat

LONDON

40 Holborn Viaduct

OPPENHEIMER BROS. & VEITH.

CUTTERS OF DIAMONDS.

Cutting Works
43-45-47 John Street

NEW YORK
65 Nassau Street

R., L. & M. FRIEDLANDER

IMPORTERS OF

DIAMONDS

30 MAIDEN LANE, - - - NEW YORK CITY

MEYEROWITZ BROS.

IMPORTERS OF

DIAMONDS

PRECIOUS and
SEMI-PRECIOUS STONES

ESTABLISHED 1896

NEW YORK: 37-39 Maiden Lane
PARIS: 58 rue de Maubeuge
AMSTERDAM: 2 Tulpstraat

MEYEROWITZ BROS

MEYEROWITZ BROS

REPOUSSÉ WORK AND CHASING*

ILLUSTRATED AND DEMONSTRATED BY AN EXPERIENCED ARTISAN

(Continued from issue of March 11.)

THE USE OF FIGURE WORK.

THE development and greater use of figure-work led to a new and beautiful method of enameling. Figure compositions were now carved or worked in repoussé in low relief, and perfectly transparent enamel was fired over these, so that all the details and modeling of the surface underneath was seen through a brilliant film of color. This is termed translucent enamel, and can be seen in most of the more important pieces of gold and silverwork of the 13th, 14th and 15th centuries.

Shrines and reliquaries were made in great numbers, mostly in the form of churches and chapels, made up of numbers of pieces of plate soldered together, while

with large doors, buttresses with many small pinnacles, and a spire. The surface ornamentation is carried out by means of engraving and niello-work, as well as filigree-work, and stones. In addition, a system of crockets and leaves about the arches and twined around the volutes, gives a rich appearance to the whole work. Finally, as in all elaborate 13th century work, the shrine is completed with figures in the round and bas-reliefs representing the saint and scenes from his life.

An elaborate reliquary, belonging to the Rothschild collection in the Louvre, but originally from the Abbey of Floreffe, is in the same style. It is in the form of a triptych, of Flemish workmanship of the 13th century. In the central piece two angels support the cross, while in the wings

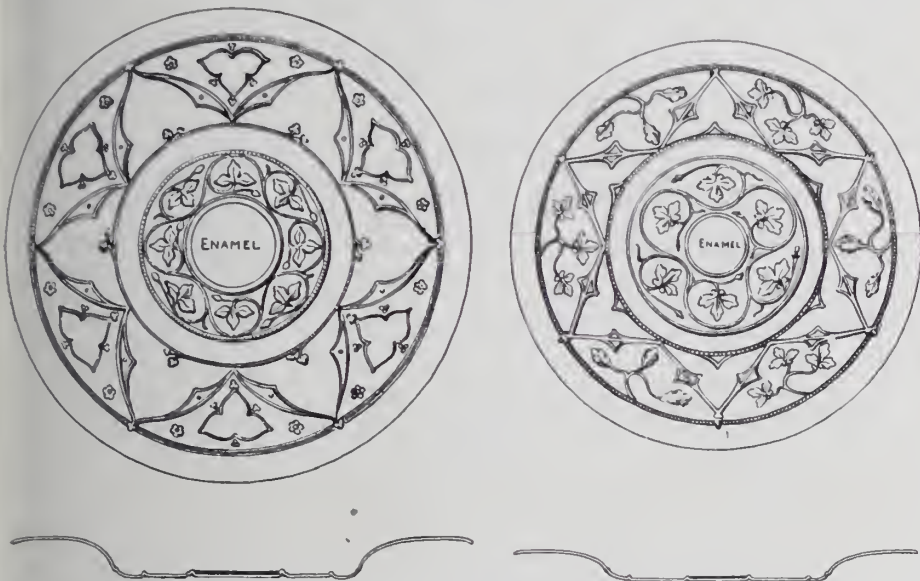

TWO SILVER BOWLS WITH ORNAMENT OF REPOUSSÉ NOW IN VICTORIA AND ALBERT MUSEUM, LONDON.

in the niches or recesses, into which the main body was divided, and which in this style naturally became numerous, were fixed images of saints and personages connected with the Church. These were generally beaten out of sheet metal, not cast. Conventional foliage was now also well developed. In place of the stiff and angular foliage to be seen on work of the 10th and 11th centuries, we get the bold but graceful foliage which is one of the most noticeable features of the Gothic style, worked in sheet metal as a rule, and showing a complete mastery of form and technique.

THE SHRINE OF ST. TAURIN.

One of the finest shrines still in existence is the shrine of St. Taurin, at Evreux (France). It is of the 13th century, and all the methods of treatment which were then known were employed in the making of it. The general plan is that of a church,

are shown scenes from the life of Christ, the crucifixion, the descent from the cross besides various other figures. In both of these pieces the sound knowledge of the figure possessed by the artist is apparent, and marks a great improvement on similar work of the previous period.

At the end of the 13th century, a new object was added to the already large list of ecclesiastical vessels. This was the monstrance made for holding and carrying the consecrated wafer, the necessity of which arose at the festival of Corpus Christi, first instituted by Urban IV., in 1264. The most notable of mediæval monstrances still in existence is the one belonging to the Castle of Sedletz in Bohemia, which dates from the 15th century, and is unsurpassed by any other known specimen for the beauty of its design and the wonderful technique displayed in the mounting of its almost innumerable buttresses and pinnacles, which form one of the chief characteristics of its design.

FOR COMMUNION.

Chalices, pyxes, tabernacles, and censers were worked in a similar way. Architectural forms and peculiarities, as well as Gothic foliage, are always in evidence, while the different technical processes then known were used with good effect. Chalices, which previous to this period had round feet, generally decorated with filigree-work and stones, were now made with lobed feet, decorated with enameled medallions and embossed foliage. A change, too, is noticeable in the cup of the chalice, which before had been wide and shallow, but was now made deep and narrow, and very often fitted into a sort of calix or outer cup, before being fixed on to the stem above the knop. Pastoral staves, or croziers, which before this time had been bold and simple in shape, were now made of great richness, the knop below the actual crook generally being developed into an architectural structure.

From the 13th century onward, the industrial arts (especially that of the metal-worker) ceased to be confined to the cloister; the goldsmiths' guilds being formed about that time. Very little remains of household plate, or other secular objects, in gold and silver of the 13th, 14th, or 15th centuries; but we have many descriptions in manuscripts of the period. The wealth of princes and nobleman at this period was immense, the Court of the Dukes of Burgundy being the most sumptuous and costly of the Middle Ages. In royal and noble houses of that period, the guests washed their hands before and after dinner in perfumed water, which was served in elaborately wrought silver or bronze dishes. Two of these dishes, of which a sketch is shown, are now preserved in the Victoria and Albert Museum, South Kensington. They were discovered with a number of spoons and gold coins of the reign of Philip of Valois (King of France, 1328-1350), when demolishing an old house in Rouen in 1864. They are of silver parcel-gilt, decorated with embossed and chased geometrical tracery and foliage in the best Gothic style. The center of each dish originally held an enamel, which has now been restored. Even as late as the latter half of the 14th century only knives and spoons were in general use at table, forks being practically unknown.

(To be continued.)

Police of Paterson, N. J., have sent out a general alarm for the arrest of a well dressed man who swindled Harry Chapman, 25 N. Main St., out of four watches to the value of about \$150. Chapman was alone in the store when a man who introduced himself as "Mr. Kaufmann" entered and asked to see some ladies' watches. The display did not seem to satisfy him, and, not wishing to lose a customer, Chapman went to a store close by and soon returned with four watches. The stranger could not make a selection, and suggested that the jeweler go along with him and let his "girl" decide. Together they went to 108 Water St., where Chapman was ushered into the parlor and the stranger took the watches to show to his girl, who was "upstairs." Chapman remained in the parlor for some time before he realized he had been duped.

*All rights reserved. Copyright, 1907, in the United States by the Jewelers' Circular-Publishing Co., and in Great Britain by the Watchmaker, Jeweler, Silversmith and Optician.

OFFICE OF
H. Z. & H. OPPENHEIMER
IMPORTERS AND CUTTERS OF DIAMONDS
1 MAIDEN LANE, NEW YORK

To Our Customers

Do not be misled by the exaggerated and prevaricated reports appearing in the various papers. For some reason unknown the press of the country, for the purpose of sensationalism, has lately made it a point to exaggerate every occurrence in our line, when it is a fact that the panic we have passed through has affected not only our line, but every other business and industry in the country. Why then do they select the Diamond business for special condemnation?

True, there have been failures and business troubles, just as in all other lines of business, but if they are carefully examined into, it will be found that most of them were caused either by outside speculation or some special reason.

There are proportionately as many solvent, upright and honorable merchants in the Diamond business as in any other line. The Diamond mines are controlled by two companies, and their entire output does not exceed the total sum of \$30,000,000 yearly, which can be and is easily controlled, and these companies will certainly not do anything detrimental to the interests of their clients, which would be equivalent to "cutting off their own noses."

Through our representatives in London we have the assurances of both the De Beers and the Premier Companies, as well as from the London Syndicate, that under all circumstances prices will be maintained.

Business may be quiet for a little while, but it will gradually improve, and in the meanwhile remember that Diamonds do not eat anything, nor will they rot, nor yet require a warehouse to store them. General business is improving and the Diamond trade will soon get its share.

We are in a position to render assistance to such of our customers as are worthy and may require it.

Very truly yours,

H. Z. & H. OPPENHEIMER.

Corporation Reports Filed by Jewelry Manufacturing Concerns of Massachusetts.

Boston, March 11.—The annual corporation reports of several jewelry and optical houses in Massachusetts were made public to-day at the office of the Secretary of State. The figures follow:

T. I. Smith Co., North Attleboro; report filed by Treasurer Theron I. Smith; real estate, \$48,433; machinery, \$66,097; cash and debts receivable, \$136,597; manufactures and merchandise, \$50,000; capital stock, \$150,000; accounts payable, \$61,439; profit and loss, \$89,688.

Leach & Garner Co., Attleboro; report filed by Treasurer Stephen H. Garner; machinery, \$15,000; cash and debts receivable, \$107,164; manufactures and merchandise, \$15,629; capital stock, \$12,000; accounts payable, \$48,881; surplus, \$76,912

William H. Saart Co., Attleboro; report filed by Treasurer George J. Kelley; machinery, \$21,720; cash and debts receivable, \$45,625; manufactures and merchandise, \$13,359; patent rights, \$2,000; trade-marks, \$3,000; capital stock, \$15,000; accounts payable, \$28,111; profit and loss, \$47,593.

E. A. Fargo Co., Taunton; report filed by Treasurer Edwin A. Fargo; real estate, \$1,150; machinery, \$15,451; cash and debts receivable, \$9,500; merchandise, \$11,568; treasury stock, \$11,600; capital stock, \$30,000; accounts payable, \$2,710; floating debt, \$15,594; profit and loss, \$2,976.

Boston Optical Co.; report filed by Treasurer William P. McEvon; machinery and fixtures, \$3,010; cash and debts receivable, \$19,860; manufactures and merchandise, \$35,713; capital stock, \$30,000; accounts payable, \$8,974; floating debt, \$10,700; surplus, \$3,909.

Globe Optical Co., Boston; report filed by Treasurer Albert G. Barber; machinery and fixtures, \$8,381; cash and debts receivable, \$77,905; manufactures and merchandise, \$97,070; stock in other corporations, \$15,900; capital stock, \$70,000; accounts payable, \$14,968; floating debt, \$46,600; dividends and due officers of company, \$7,470; profit and loss, \$45,218; reserved for depreciation, \$15,000.

Three Thieves Boldly Smash Window of York, Pa., Jewelry Store, and Secure Rings Worth \$600.

LANCASTER, Pa., March 11.—A remarkably bold robbery was committed at York on the evening of March 9, with scores of people on the street outside the store and the proprietor and clerks within. The victim was Archie W. May, whose place of business is at 411 W. Market St.

Three men walked up to one of the show windows and two of them smashed the plate glass by striking it with their elbows. The third caught up three trays of rings, worth nearly \$800, and emptied most of the rings into a satchel which one of his companions held open. Many rings were dropped upon the sidewalk and afterwards recovered, but about \$600 worth went into the bag.

The thieves fled, pursued by a crowd, one losing his hat in the chase, the only clue left behind. The fellows escaped with their booty, though two boys were close

enough to recognize them, and can identify any, if caught.

The day after the robbery Charles Harris, of Westfield, Mass., an engraver, was arrested on suspicion, because he was hatless and was begging. He was locked up for examination.

Three men several months ago attempted a bold theft of diamonds at Louis Weber & Son's store, Lancaster, and it is not unlikely that the York thieves may have been those who operated in Lancaster.

Jewelry, Clocks, Watches, Silverware and Kindred Lines Exported from New York.

WASHINGTON, D. C., March 11.—The following were the exports of jewelry, silverware, optical goods, clocks, watches and kindred lines from the Port of New York for the week just ended:

- Berlin: 12 cases clocks, \$760.
- Bremen: 2 cases watches, \$371.
- Buenos Ayres: 4 cases watches, \$2,269.
- Cape Town: 6 cases clocks, \$198; 4 cases plated ware, \$413
- Cayenne: 4 cases plated ware, \$153.
- Calcutta: 14 cases clocks, \$371; 157 cases clocks, \$2,103; 62 cases clocks, \$1,101; 57 cases clocks, \$4,638.
- Christiana: 12 cases clocks, \$476.
- Cristobal: 1 case plated ware, \$442.
- Curacao: 12 cases clocks, \$174
- Gilbara: 3 cases plated ware, \$358.
- Guayaquil: 1 case watches, \$105.
- Hamburg: 66 cases clocks, \$326; 1 case plated ware, \$250; 3 cases optical goods, \$1,649.
- Havana: 1 case silverware, \$114; 68 cases clocks, \$879; 30 cases clocks, \$786; 1 case jewelry, \$306; 12 cases clocks, \$353; 1 case jewelry, \$149.
- Hong Kong: 184 cases clocks, \$2,372.
- Liverpool: 126 cases clocks, \$1,857; 247 cases clocks, \$4,199; 5 barrels jewelers' sweepings, \$7,000; 3 cases jewelry, \$373; 1 case silverware, \$175; 1 case jewelry, \$1,000; 2 cases watch material, \$1,500; 24 cases clocks, \$397; 2 cases silverware, \$250; 1 case jewelry, \$250; 10 cases watches, \$1,977; 4 cases optical goods, \$1,397; 4 cases thermometers, \$282.
- London: 48 cases clocks, \$1,658; 4 cases optical goods, \$2,091; 2 cases plated ware, \$381; 129 cases clocks, \$3,751; 5 cases watches, \$281.
- Melbourne: 117 cases clocks, \$1,591; 45 cases clocks, \$883; 6 cases optical goods, \$850; 4 cases clocks, \$200.
- Montevideo: 4 cases plated ware, \$320.
- Oporto: 29 cases clocks, \$277.
- Pt. Antonio: 1 case jewelry, \$176.
- Rio de Janeiro: 17 cases clocks, \$288; 5 cases watches, \$1,887.
- Shanghai: 23 cases clocks, \$405.
- Santiago: 3 cases plated ware, \$139.
- Southampton: 19 cases watches, \$3,351; 1 case optical goods, \$387.
- Stockholm: 9 cases clocks, \$183.
- St. Johns: 14 cases clocks, \$203.
- Tampico: 18 cases clocks, \$226; 1 case watches, \$160.
- Trinidad: 5 cases watches, \$253; 3 cases clocks, \$52.
- Valparaiso: 39 cases clocks, \$909.
- Yokohama: 50 cases clocks, \$1,439.

Word was received from Niagara Falls, Ont., last week, that E. S. Cole, a jeweler on Erie Ave., had been robbed one evening recently of a tray of diamonds valued at \$400. The thieves are supposed to be two men who visited Mr. Cole's shop and asked to see some brooches. While his back was turned it is thought they took the tray of diamond rings, as they hurriedly left the store and the rings were then missed. A man suspected of being one of the thieves was arrested on the American side shortly afterward, but when taken back to Canada Mr. Cole could not identify him as the thief.

Sale of Walter E. Hayward's Business Due to His Breakdown in Health from Overwork.

ATTLEBORO, Feb. 14.—The change in ownership of Walter E. Hayward's manufacturing jewelry business, referred to briefly last week, takes out of the Attleboro trade circles a man who has been quietly conspicuous there for years. In the retirement of Mr. Hayward Attleboro loses a public-spirited and personally popular man.

The business was founded considerably over a half century ago under the name of Thompson & Hayward, but its career under that style was brief, and the practical start was made in 1851 as Hayward & Briggs. The head of the firm was Charles E. Hayward, one of the ablest pioneers in the industry the town had. On the retirement of his partner some years later he ran it as Charles E. Hayward & Co. The name was changed again when he took in as partner George L. Sweet, under the style of Hayward Sweet. The latter left after a few years to become traveling man for the R. F. Simmons Co.

Mr. Hayward passed away, dividing his estate between his two children, Mrs. Joseph L. Sweet and Walter E. Hayward. The latter ran it in his own name since 1898, and did so successfully. Like other concerns it received a temporary set-back by the fire which destroyed 17 of the local factories, May 18, 1898, but its progress since has been satisfactory. Mr. Hayward threw himself into the work with a zeal which proved his physical undoing. Defective eyesight warned him of the risk of a break-down, but the past few years had been such a bonanza period he could not bring himself to work easier. He put in night and day at his office, ran two shifts of workers, and then collapsed. He suffered a shock which affected his health to a degree that makes complete recovery seem too much to hope, and he is now in a hospital at Newton, critically ill.

Owing to his condition his affairs were placed in the custody of the Probate Court, which appointed Harold E. Sweet, of the R. F. Simmons Co., conservator. The latter had the advantage of expert assistance from his father, Joseph L. Sweet, and disposed of the business, dating from March 1, to Charles C. Wilmarth, of Attleboro, and Frank J. Ryder of New York.

The change will make little or no difference to the trade in its direct dealings. Mr. Wilmarth joined the concern 21 years ago, as foreman, and has been in full charge of the factory ever since. In recent years Mr. Hayward has left the practical details of getting out the work wholly to him. A partnership had been contemplated, but Mr. Hayward was stricken before he carried out the plan. Mr. Ryder has been with the house since 1901.

The new owners will do business as Walter E. Hayward Co. Mr. Wilmarth will continue in charge of the plant, and Mr. Ryder will make his home in New York, and will be assisted in the east by Russell Atwell, of Attleboro, as salesman.

The show case in the store of A. Winkler, Scranton, Pa., was broken one night recently and a number of watches were stolen. Four boys were afterward arrested.

REGISTERED



TRADE-MARK

≡ RINGS ≡

REGISTERED



TRADE-MARK

RINGS are always in demand, and are always salable, provided you have the right kind to sell. We have—

RINGS of every description: signet rings, diamond rings, fancy rings, rings of every style and combination of stones.

RINGS that satisfy the most critical and appeal to every taste and fancy.

RINGS You can sell. *Write us or wire us any time. We are always ready for your order.*

HAYDEN W. WHEELER & CO., Importers

AMSTERDAM, 2 Tulp Straat

2 Maiden Lane, NEW YORK, N. Y.

'Phone, 7365 Cortlandt

LONDON, 50 Holborn Viaduct

ORDER

DIAMONDS

ON MEMORANDUM FROM

ALFRED H. SMITH & CO.

London,
6 Holborn Viaduct.

170 BROADWAY, NEW YORK.

Corner Maiden Lane.

Also 475 FIFTH AVENUE.

Chicago,
103 State Street.

F. A. JEANNE

FANCY-COLORED AND FANCY-SHAPED

DIAMONDS

5 Square de l'Opera

PARIS, FRANCE

Cable Address

“ GEMFINDER ”

Western Union Code

Gems and Precious Stones

—
Cloth, Postpaid, \$1.00
—

Published by

The Jewelers' Circular Pub. Co.

11 John Street

NEW YORK

RUDOLPH NOEL

PHILIP NOEL

RUDOLPH NOEL & CO.

IMPORTERS AND CUTTERS OF DIAMONDS

2 Tulp Straat, AMSTERDAM

37-39 Maiden Lane, NEW YORK

Manufacturing Jewelers of Newark Listen to an Important Lecture on the Subject of Technical Education as Applied to the Jewelers' Art.

NEWARK, N. J., March 16.—Under the auspices of the Manufacturing Jewelers' Association of Newark, Prof. J. C. Monaghan delivered a very instructive and interesting lecture Saturday evening in the hall of the Public Library, which was completely filled. The subject was "Technical Education as Applied to the Jewelers' Art," and Professor Monaghan was well qualified to discourse on this theme. He occupies the chair of Economics in the University of Notre Dame, Ind., but began life as a draftsman. He has filled important posts at the George Washington University, District of Columbia, and in the Bureau of Consular Service. He served as United States consul in Germany for 12 years, and while there, took occasion to make a thorough investigation of technical education abroad. Much of the lecture was devoted to comparing conditions as they exist in the United States and Europe.

George R. Howe, who presided, said in introducing the speaker that when the manufacturers were very busy they found little time for educational interests, and when they had leisure they too often overlooked them. He was glad a lively interest had now been awakened.

The lecturer said the days of "rule of thumb" had passed. A Los Angeles man retains as a curio the first pan of biscuits his wife baked. She does better now. Technical education is needed even in cooking. Italy could live on the waste of New York. French cooking excels because everything is weighed and measured. There is a law of quantity as well as quality.

We lead in masses because we have the raw materials, but not in technique and design. A large piece of tapestry made in Philadelphia was worth, perhaps, \$100, while a piece of Gobelin tapestry half the size would bring from \$25,000 to \$100,000. Bismarck says, "The nation that has the schools has the future;" but in reality it is the nation that has the schools plus the raw materials. The best schools are in Germany and Japan, the skilful fingers of the Japanese being in their favor. The president of Columbia University has said that "Education is entering into our inheritances."

We have various inheritances—literary, legal, scientific, æsthetic, etc.—but their educational application must be *useful*—must fit one for life. Professors must think outside of the covers of their books.

A Pittsburg professor, after a four months' jaunt abroad returned to say that America had nothing to learn from Europe in the matter of technical education. It would take all of that time to study a single great institution such as the technical school at Berlin. An American may say, "See what we have done without such schools." The question, however, is, What would we be without them, and what would Germany be without them? There they have a school for every industry—schools for knitting, blacksmithing, plumbing, mason work, etc.

A year in such a school is worth three as an apprentice. Can we get a "vocative system" of education in this country?

The speaker advised the appointment of a Newark commission of a non-political character, not a junketing expedition, to go abroad and study this subject at first hand, assured that the local industry would benefit thereby. A glowing tribute was paid to *L'ecole des Beaux Arts* in Paris, whose students are supplying the world with design. It is the Mecca of art students the world over. Here are genius and skill equal to that of Phidias or Praxiteles or the masters of the Renaissance.

A defect of our school system is that we suppress fancy and overlook the will. Witness the useless sons of the wealthy. Our young men are too prone to want "white shirt jobs." They prefer salary to wages, though the latter may be larger. Parents suppress art in their children. A young man is put in a bank who ought to be in a studio or workshop. Here there is a piano in every house, but no music. In Germany there are few pianos, but it is music everywhere. To learn to paint one must go to Paris, Munich or Dresden. Does it pay to acquire supreme skill?

St. Gaudens was a humble attendant at Cooper Institute, afterwards working with an obscure cameo cutter. He went to Paris. He became the finest sculptor since Angelo, only Thorwaldsen approaching him. He could command any price.

Our trusts have put the theatre and the opera beyond the reach of the poor. In Germany one can witness the works of Goethe and Wagner for a few cents. We build as if we did not intend to stay in town. Abroad a sentiment for beauty expresses itself everywhere. All this is of inestimable value in æsthetic education.

In Germany the "vocational system" prevails. By the time a child reaches the age of 10 his bent is discovered and line of life directed. He enters a developing school at 14. Drawing is an essential element. Pupils make excursions to various industries, relying wholly on their memory for the drawings and reports they have to make. So accurate were these on the occasion of a visit to the great Krupp works that the Krupps had the reports of the students suppressed. Each industrial school has its art section. If the student shows special ability he is sent to Paris free of expense, the only condition being that he return and teach. Valuable collections are often bought for the inspiration of students.

Assuming the pupil to be studying the jewelers' craft, all materials are supplied—solders, blow-pipe, bench work, etc. When the boy finishes his course he enters the factory, which is well lighted and ventilated and *free from dust*. His preliminary training avoids waste. Die-work abroad costs one-fifth less than here. The boys are placed beside older men, whose methods they observe, and the latter can check the errors of the former. The workmen know

their work and are familiar with the history of art. They are ethnologists, knowing the tastes of different nations, and they are familiar with all the sources of supply. The factories also have accomplished linguists, capable of conversing with men of diverse races; and in view of all these facts it is no wonder their products go all over the world. Many famous factories are themselves schools, such as the famous porcelain works at Sèvres and Dresden. There is always a deficit at Meissen, but the work is maintained. Emigration from Germany has almost ceased.

In this country we should begin on the art side, as we have good institutes of technology such as that in Boston. The Textile School in Philadelphia is one of the best in the world, and it is very successful. What has been done elsewhere can be done in Newark. And see to it that you make your building beautiful.

In presenting a vote of thanks to the speaker, Dr. A. B. Poland, superintendent of the Board of Education, outlined what had already been accomplished in Newark. He referred to the local technical school and the evening drawing school with an attendance of over a thousand. The Board of Education has a manual training high school in view. A State committee is taking up the general subject of technical education. Dr. Poland thought we excelled in our kindergarten work, but failed in dealing with pupils after the age of 14. When they leave the grammar school we hardly know what to do with them.

The lecture suggests a direction for advance.

Milwaukee Jewelers, at Formal Meeting, Decide to Donate Their Clocks to the City.

MILWAUKEE, Wis., March 13.—Milwaukee jewelers will formally donate their clocks to the City of Milwaukee, according to action taken at a meeting of the Milwaukee Jeweler's Club, at the Blatz Hotel.

Resolutions, in which it was set forth that the clocks had always been maintained on the public streets, had always proved a public benefit, and had ever been demanded by the public, were passed. These resolutions also declared that the clocks had recently been ordered razed by the city; that some of them suffered considerable damage during the process; but that, in spite of all, the jewelers were ready to repair them, to re-erect them, and maintain and operate them at their own expense. The resolution concludes with an appeal to the common council to accept them as gifts and allow their re-erection.

The clocks are to become public property. In other words, they are to be operated exactly as they always have been operated and will be placed in the same locations they have always occupied. Alderman Yockey attended the meeting and was engaged as attorney, together with Carl Runge, to fight for the jewelers in case such a course should become necessary.

The jewelers discussed the clock question for hours. Many views were expressed, most of them grilling Mayor Becker and all of them favoring donation of the clocks. In the event of non-acceptance by the council the jewelers are preparing to fight.

An EXHIBITION *of* GEMS ROUGH AND CUT

March 24th to 28th inclusive, at 537 Fifth Ave., N. Y.



THIS exhibit is for the purpose of better acquainting the jewelry trade and the public with our product of Precious and Semi-Precious stones both in the rough and cut. Among the minerals exhibited will be Tourmalines, Chrysoprases and Turquoises from our own mines situated in the state of California. We will show these goods in the process of cleaving, cutting and polishing as well as an exceptionally fine display of Gem Crystals. These gems both in brilliancy and beauty cannot be excelled.

We extend a cordial invitation to the entire trade, and a treat is in store for those who will visit the display. We trust that we shall have the pleasure of greeting you and showing you through the exhibit.

Respectfully,

HIMALAYA MINING CO.

Thief Escapes with \$700 Worth of Stock from Store of Jewelers in New Haven, Conn.

NEW HAVEN, Conn., March 15.—A well-dressed stranger yesterday entered the store of S. Silverthau & Sons, and after requesting Frederick Silverthau to show him a large diamond which was on display in the window, made off with two diamond earrings which had previously been placed before him for his inspection. Frederick Silverthau and his brother Abraham dashed after the thief, who, however, was fleet of foot and managed to elude not only the jewelers but a large crowd which soon gathered and hot-footed it after the fugitive.

The stranger first came to the store three weeks ago with a valuable automobile watch which he left to be repaired. He stated that he was an actor and gave his address as New Haven. When the watch was repaired he called and paid for it. Then he returned a few diamonds and informed some of the members of the firm he had a mother-in-law who was anxious to purchase a good diamond ring. He was told to send in the relative, and a few days later another stranger called and introduced himself as that person. He inspected several rings and promised to return again with the other man. The first stranger came back last night, as mentioned above, and spent about 15 minutes looking at different rings. Finally he placed one on his finger and asked to see some earrings. As he examined a pair he requested the jeweler to show a diamond in the show window. The earrings weigh about three carats and the ring 1 1/4 carats, their total value being placed at \$700.

The stranger is described as being of dark complexion, five feet seven inches tall, and weighing about 150 pounds. He is about 30 years of age and smooth shaven. When last seen he wore a black derby hat and a wine-colored overcoat.

Germain Kern, Bankrupt Jeweler of Knoxville, Sent to Prison for Two Years.

KNOXVILLE, Tenn., March 11.—Germain Kern, a former jeweler and pawnbroker of his city, who was convicted last Thursday of falsifying his bankruptcy schedules and withholding assets from his schedules, was Saturday sentenced to two years and two days in the Federal prison of Atlanta. A motion for a new trial was denied by Judge McCall, who pronounced sentence.

The Kern case is one of the most celebrated that has been in the courts of Knoxville in many years. Kern formerly kept a large pawnbroking and jewelry establishment on South Gay St. Application for involuntary bankruptcy was filed against Kern and a receiver was appointed. Criminal proceedings were also instituted, but Kern left the country. Later he was returned from Toronto, Can. His preliminary hearing occurred before United States Commissioner Horace VanDeventer and he was held to court under bail of \$7,500. The amount was furnished.

A little later Kern, who had lost his business, his home and everything he possessed, appeared on the street one day in

David Warfield's role, "The Auctioneer." Since that time he has kept a small jewelry wagon on Wall Ave. Much sentiment in favor of Kern was aroused, though it was not denied that the charges against Kern were most serious.

C. E. Tucker, Greenville, S. C., Goes Into Voluntary Bankruptcy.

GREENVILLE, S. C., March 11.—C. E. Tucker, late of the firm of C. E. Tucker & Bro., has filed a voluntary petition in bankruptcy. His liabilities are about \$4,000 and the assets will amount to about \$2,500.

The firm of C. E. Tucker & Bro. was composed of Charles E. Tucker and his brother, Patrick R. He started in business here in January, 1902, and for a while Charles Tucker continued the business alone, but again became associated with his brother about a year ago, dissolving three months ago. They are both very young men, but have been active, the elder being only about 21 years old.

Inability to make sales during the financial depression is understood to be the reason of the failure of this jewelry concern, which has always been regarded as sound and aggressive.

The first meeting of creditors under the bankruptcy law will be held in the office of Referee Heyward, Thursday, March 19, when a trustee will be elected and other matters transacted.

Games Rolled by the Jewelers' Bowling League of New York.

The following were the scores of the teams of the Jewelers' Bowling League in the games rolled last week:

March 9.—Jos. Fahys & Co.	815	684	829
vs. L. E. Waterman Co.	656	793	804
March 10.—Cooper Diamond Co.	902	833	1,045
vs. Julius King Optical Co.	828	766	759
March 11.—Tiffany & Co.	844	774	841
vs. H. W. Wheeler & Co.	698	735	880
March 12.—C. F. Wood & Co.	814	834	931
vs. Aikin Lambert Co.	848	819	882
March 13.—N. H. White & Co.	909	932	916
vs. L. E. Waterman Co.	823	713	758

STANDING OF THE TEAMS.

	Won.	Lost.	High score.	Per cent.
Cross & Beguelin.	41	13	1,017	.759
N. H. White & Co.	41	13	1,014	.759
Cooper Diamond Co.	39	21	1,045	.650
C. F. Wood & Co.	27	15	943	.643
Tiffany & Co.	34	23	994	.596
Aikin Lambert Co.	31	26	967	.544
Jos. Fahys & Co.	29	28	951	.509
A. A. Webster & Co.	19	35	916	.352
H. W. Wheeler & Co.	13	38	922	.255
Julius King Optical Co.	10	41	889	.196
L. E. Waterman Co.	10	41	879	.196

Market Price for Silver Bars.

The following are the quotations of silver bars in London and New York, as reported by Zimmermann & Forshay:

	London.	New York.
March 11.	25 9-16d.	\$.55 3/4
" 12.	25 9-16d.	.55 3/4
" 13.	25 3-4d.	.55 3/4
" 14.	25 5-8d.	.55 1/2
" 16.	25 9-16d.	.55 3/4

Herman Stocker has retired from the jewelry firm of L. Stocker Sons, Macomb, Ill., having sold his interest to LeRoy Stocker, who will conduct the business in future with his father, Edward Stocker. The firm name will remain unchanged.

Rewards Paid and Members Elected by the Jewelers Security Alliance.

The regular monthly meeting of the executive committee of the Jewelers Security Alliance was held on Friday, the following members being present: Chairman Butts, President Sloan, Vice-Presidents Champenois and Wood, Treasurer Karsch, Secretary Noyes and Messrs. Abbott, Alford, Bowden and Brown of the committee. The following new members were admitted:

- Belding Bros., Portland, Ore.; H. W. Bounds, Dallas, Tex.; G. W. Galloway & Son, Binghamton, N. Y.; N. Goldstein & Son and H. Hawley Co., Dallas, Tex.; D. H. Keene and Levy Bros., Ft. Worth, Tex.; W. W. Mitchell, Dallas, Tex.; A. E. Sheets & Co., Lexington, N. C.; Theberath & Co., Inc., Newark, N. J.; Conn Jewelry Co., Bowling Green, Ky.; N. J. Felix, New York; A. Kurtzborn, Jr., St. Louis, Mo.; S. E. Phillips & Co., Mannington, W. Va.; Stearns & Hill, Keene, N. H.; Weisbaum & Son, Hanford, Cal.; Louis A. Borsheim, Omaha, Nebr.; W. I. Hatch, Lancaster, N. H.; C. M. Henkel, Bisbee, Ariz.; Quimby & Quimby, Claremont, N. H.; Stern Bros. & Co., New York; A. M. Yeakel, Perkasi, Pa.; R. E. Boemig, Woodsville, N. H.; Holder & Landsadel, New York; Frederick King, Barre, Vt.; Daniel Sargent, Delphos, Kans.; H. C. Stearns, Lakeland, Fla.; Herbert L. Terry, Sayville, N. Y.; P. H. Shuey, Red Bluff, Cal.; F. Bucher & Sons, Baltimore, Md.; E. Jaschik, Philadelphia, Pa.; Andrews & Co., Providence, R. I.; Queen City Loan Co., Seattle, Wash.; C. B. Brown Co., Omaha, Nebr.

The 46th reward of \$100 was ordered paid to the police of Dayton, O., for the arrest and conviction of George Geissman and Lawrence Koors, who broke into the store of Wm. J. Burkhardt of that city Jan. 7 and stole about \$500 worth of jewelry. The police noticed one of them walking up and down before the store at 1 A. M. as a lookout, and attempted to arrest him, but he got away in spite of four shots fired at him. Mr. Burkhardt offered the reward under instructions from the secretary of the Alliance, which stimulated the police so that they soon captured the thieves and recovered all the goods. The burglars pleaded guilty and were sentenced to an indeterminate term in the Mansfield Reformatory.

W. P. McFarland, Orange, Tex., Files a Voluntary Bankruptcy Petition.

ORANGE, Tex., March 11.—W. P. McFarland, a retail jeweler of this town, has filed a voluntary petition in bankruptcy. His liabilities are about \$23,400. The secured creditors aggregate \$2,500, and the unsecured \$19,557. There are also preferred claims of \$350. His assets consist of stock and accounts, etc., valued at about \$18,000; real estate, \$2,500; machinery, etc., \$2,000; household goods, \$1,000. An effort is now being made to obtain a settlement with his creditors, and it is believed that this will be successful and that Mr. McFarland will soon be able to resume. The first meeting of creditors will be held March 21.

Mr. McFarland began business in March, 1902, and by his industry and ability built up an excellent trade. He carried a good stock and was believed to have done well until recently, though it was known that he had been suffering from lack of cash owing to business conditions, and a short time ago sought an extension from his creditors.

The store of Thomas Erickson & Son, Red Wing, Minn., has been closed on account of the illness of both partners.

Cameos = Scarabs = Carbuncles

Notwithstanding the difficulty generally experienced at present in supplying the sudden demand for these goods, we have succeeded, thanks to our firmly established connections with the stone centers of Europe, in making arrangements for the uninterrupted supply of them, and are, therefore, fully prepared to fill all orders for these articles with the greatest possible dispatch.

CAMEOS — ONYX, PINK and BROWN SHELL, and CORAL

SCARABS and CARBUNCLES } RED and BROWN SARD, BLOODSTONE, MOSS AGATE, GREEN AGATE, NEW ZEALAND and CHINESE JADE, AMAZONITE, TIGER EYE, CORAL and TURQUOISE MATRIX

In all regular and special shapes and sizes

L. Heller & Son

Importers of Precious and Imitation Stones
68 NASSAU STREET, NEW YORK

PARIS
39 Rue de Chateaudun

PROVIDENCE
212 Union Street

IDAR
14 Hauptstrasse

Goodfriend Bros.
IMPORTERS OF **PEARLS**

Sapphires
Rubies
Opals
Emeralds

Aquamarines
Peridot
Gem Coral
Tourmalines

and OTHER
Precious and Imitation Stones

PEARL-OPAL-CORAL
& AGATE NECKLACES

PARIS:
10 Rue Cadet.

PROVIDENCE:
212 Union St.

9-11-13
Maiden Lane
NEW YORK

Geo. Brunswick, N.Y.

TURQUOISE

Matrix - Turquoise

Best the World Produces

WE ARE prepared to furnish to the trade Matrix-Turquoise in all shapes and sizes.

Exquisite Color and Markings

We cut Turquoise to order

Mines at Mojave County, Arizona

THE ARIZONA
TURQUOISE MINES CO., Inc.
Cutting Works and Sales Office
171 Broadway, New York

SEND FOR CATALOG

Telephone 5728 Cortlandt

Diamond Importer Says He Was Hypnotized by Debtor.

Bankruptcy Petition Filed Against Maurice C. Dreshfield by Creditor Who Claims He Got Diamonds Worth \$182,549 on False Representation.

A petition in involuntary bankruptcy was filed last Wednesday in the United States District Court, New York, against Maurice C. Dreshfield, 170 Broadway, New York, by Rudolf A. Breidenbach, a precious stone importer, Henry C. Morath and Linn Wagner, all of New York, in which it is alleged that Dreshfield, in conjunction with George H. Carpenter, a manufacturer of fire appliances at 17 E. 32d St., New York, obtained diamonds valued at \$182,549 from Mr. Breidenbach upon alleged fraudulent statements made by Dreshfield and Carpenter regarding the latter's financial condition.

The petition recites that Mr. Breidenbach, "relying upon the false and fraudulent representations of Maurice Dreshfield, accepted 33 promissory notes made by the said George H. Carpenter, mostly all payable to the said Maurice C. Dreshfield and endorsed by the latter, and then for and in consideration of the delivery of said diamonds to the said Maurice C. Dreshfield and George H. Carpenter, the said Dreshfield and Carpenter handed the said promissory notes over to the said Rudolf Breidenbach, many of these notes having been protested for non-payment."

The petition further alleges that Carpenter had in his possession four promissory notes aggregating \$35,000, alleged to have been made by the William Kavanaugh Co., Norwalk, O., and payable to the Norwalk Steel & Iron Co., Norwalk, O., and Carpenter is alleged to have falsely represented to Mr. Breidenbach that the companies were in excellent financial condition, and that the notes would be paid when due, and Carpenter is alleged to have guaranteed the payment on the notes which were protested for non-payment. The petition goes on to say that Dreshfield and Carpenter represented to Mr. Breidenbach that Carpenter was the president of the Monarch Fire Appliance Co., and that a vast amount of money would be made by this company, and in consideration of the delivery of the diamonds Mr. Breidenbach was to receive from Carpenter a large amount of stock in the fire appliance company, which has not been done.

It is claimed that between Sept. 9, 1907, and Dec. 30, 1907, diamonds valued at \$182,549 were obtained from Mr. Breidenbach, and that on this account \$9,445 was paid. The claims of the other two petitioners are for much less amounts; that of Henry C. Morath is for \$2,854, and that of Linn Wagner, \$1,550.

The petition charges that both Dreshfield and Carpenter are insolvent and committed acts in bankruptcy by disposing of diamonds valued at \$173,103.

Judge Holt appointed William Lesser, of Lesser Bros., receiver, under a bond of \$1,000.

A petition was also filed against George H. Carpenter.

Solomon Oppenheimer, attorney for Mr. Breidenbach, when asked by a CIRCULAR-

WEEKLY reporter how his client came to allow so much valuable property to leave his possession without getting ample security, said that Mr. Breidenbach was in a way hypnotized or unduly influenced. "Mr. Breidenbach thought he would make money in the fire appliance company in addition to his diamond business," said Mr. Oppenheimer. "He knew Mr. Dreshfield and had confidence in him, having had previous dealings with him."

Mr. Oppenheimer said that Dreshfield introduced Carpenter to Mr. Breidenbach and that they went out dining, and that Mr. Breidenbach was greatly influenced by Carpenter's personality. He also said that an attempt had been made to get the men to return the diamonds, but without success. "About \$60,000 is now due on the notes," said the attorney.

Mr. Oppenheimer added: "This matter will not affect creditors of Mr. Breidenbach in any way, as he is thoroughly solid financially, and owns real estate in the Bronx and in the downtown district which is unincumbered."

The transactions looked all right, said Mr. Oppenheimer, as Mr. Breidenbach investigated and visited Bridgeport, Conn., where he found quite a large plant operated by the Monarch Fire Appliance Co., of which Mr. Carpenter is president.

The diamonds were delivered in lots, valued as follows: Sept. 9, 1907, \$5,733; Sept. 17, \$14,809; Sept. 24, \$9,858; Oct. 2, \$31,162; Nov. 9, \$6,998; Nov. 17, \$27,445; Nov. 26, \$3,342; Nov. 27, \$15,317; Dec. 7, \$22,701; Dec. 30, \$45,378, or \$182,540 in all.

Maurice C. Dreshfield was taken before United States Commissioner Alexander Saturday and examined by Receiver William Lesser. The object of the examination of the alleged bankrupt was to ascertain what had been done with the jewels on which the sum of \$173,104 is still due the petitioning firm of Rudolph A. Breidenbach, according to the papers filed, and to learn if it is possible to recover any of the property.

Mr. Dreshfield when questioned said he lives at New Rochelle and described himself as "Carpenter's fiscal agent." He admitted that he had sold and pledged the jewels obtained from Mr. Breidenbach for less than half their value, and that while commissions aggregating \$30,000 are still due him thus far, he has made but \$1,500 out of the transactions. Dreshfield said he turned over all the money realized by sales to jewelers, pledges from pawnbrokers, and loans from banks in this city, Philadelphia, Baltimore and Washington to Carpenter for the Monarch Fire Appliance Co. of Bridgeport, Conn., which corporation, he understood, the Maiden Lane merchant was desirous of helping. In addition to this, the witness said, Breidenbach was fully aware of the way the jewels were disposed of, and consented in writing to the pledges made on the stones by pawnbrokers and also the loans by banks.

He testified that he paid Joseph L. Greenwald, president of the People's Trust Co., Philadelphia, \$1,000, for a four months' loan of \$10,000. He said that he had accounts with the Chatham National Bank, and he claimed he accounted to Carpenter for all goods received from Mr. Breidenbach—in all about \$200,000.

William Lesser, receiver in bankruptcy of Dreshfield, was Monday appointed auxiliary receiver for any property of Dreshfield's, in Philadelphia, with a bond of \$20,000, and an injunction had been obtained there restraining the Central Trust Co., of that city, and several firms and individuals from disposing of diamonds pledged or hypothecated by Dreshfield. Mr. Lesser also said that he made a motion before Judge Holt to compel Dreshfield to turn over \$50,000 worth of diamonds, and Judge Holt referred the matter to a special master to take testimony.

Short Change Swindler Who Has Been Operating in Brooklyn Gets Diamonds from a Pawnbroker.

The police of this borough and Manhattan are looking for a thief who recently stole \$1,370 worth of diamonds from Simpson's pawnshop on Myrtle Ave., Brooklyn, after he had made an unsuccessful attempt to get away with a similar amount of jewels in a Fulton St. store.

The thief visited the store of Henry Healy, 435 Fulton St., Brooklyn, and asked to see some diamonds which he examined and selected a number which would amount to \$1,375. The stranger pulled out a roll of bills, but said he did not have quite money enough, so started with the salesman to the Brooklyn Bank. The two walked down Fulton St. to Pierrepont, where the stranger suddenly halted and said he thought he might be able to get a check cashed in a nearby liquor store.

Leaving the salesman standing on the corner, the chap darted into the saloon. He reappeared on the street after a few moments and said he would have to turn back and stop in the Mechanics' Bank. Into the bank went the pair, and here on a desk the stranger counted over his money, only to find that he was still a few dollars short, he said. The chap evidently decided that the salesman could not be fooled, so said he would call at the store and left the bank.

Shortly afterward the stranger entered Simpson's pawnshop and selected \$1,370 worth of gems and placed a number of bills on the counter.

The clerk, after counting the money, ascertained there was just \$1,369 in the roll, and so informed the stranger. The latter picked up the money and began counting it over and agreed with the clerk. He pushed a silver dollar toward the clerk and, handing back what the latter supposed was the \$1,369, hurriedly departed with the gems. A moment or two after the stranger had hastily departed with the diamonds the clerk found he had just 19 \$1 bills and a silver dollar.

The police were promptly notified and, while they have spent much time without getting any trace of the thief, they still have hopes of landing him. The man they seek is said to be 26 or 27 years old, weighs about 130 pounds and is five feet six inches in height and of dark complexion.

DIAMOND MARKET IN NO DANGER.

Absurd Newspaper Stories Due to Errors and Ignorance—Premier Company Has No Thought of Lowering Prices Even if Syndicate's Contract is Not Renewed—Negotiations for a Renewal Still On—Syndicate to Maintain Prices as Hitherto.

IN spite of all the evidence to the contrary, the newspapers of the United States, last week, continued to publish their silly reports speculating upon the diamond market and predicting all sorts of dire troubles if the present contract between the Syndicate and the Premier Mining Co. should not be renewed when it expires March 29. Cables from London received in New York, however, showed that all these reports and rumors were absolutely baseless, without the slightest foundation and fact; that the Premier Co. had given no intimation that it would not renew its contract; that the negotiations for the renewal of the same with the Syndicate were still on, and in addition to all this that the Premier Co. had no intention whatsoever

of lowering prices, regardless of the question of whether or not the present agreement with the Syndicate is renewed. This policy of the Premier Co. is announced in the cable received in New York Monday which is published herewith together with the cable from L. & A. Abrahams, the head of the Syndicate, announcing that the "Syndicate firmly intends to maintain prices as hitherto."

These two cables coming from the highest authentic sources of information should set at absolute rest once for all this speculation as to the future of the diamond market, as they come officially to the Diamond Cutters' Association, of New York, which produces about 99 per cent. of the diamonds cut in the United States. It is expected

that the news received in these cables will for a time at least put a quietus on the sensational newspaper reports in regard to the diamond market.

In behalf of the newspapers, however, it should be said that many of the reports that came out last week in regard to the break in the diamond market were based on a mis-understanding of the despatches from London. For some time past there has been considerable activity in the shares of the De Beers Consolidated Mines, Ltd., and those of the Premier Mining Co., Ltd. and the financial depression all over the world which decreased the sale of diamonds has had an effect on the prospective profits of these companies, and consequently the shares went down to a considerable extent. This, coupled with an evident attempt to depreciate the values of these shares for stock jobbing purposes, caused a slump that was commented upon in the London papers, and the reports from London and Paris about the "drop in the market" which referred entirely to the *stock market* and the *shares* of the diamond com-

T. W.

COMPAGNIE FRANÇAISE DES CÂBLES TÉLÉGRAPHIQUES.

NEW YORK.

- 44 BROAD ST. (ALWAYS OPEN)
TELEPHONE, 451 & 452 BROAD
- PULITZER BUILDING, PARK ROW.
TELEPHONE, 2089 BEEKMAN.
- 3 MERCER STREET,
TELEPHONE, 1238 SPRING
- 1 WORTH STREET,
TELEPHONE, 394 FRANKLIN.
- 581 BROADWAY,
TELEPHONE, 1238 SPRING
- 65 FIFTH AVENUE,
TELEPHONE, 1004 STUYVESANT.
- 281 FIFTH AVENUE,
TELEPHONE, 397 MADISON SQ.
ORLEANS, MASS.

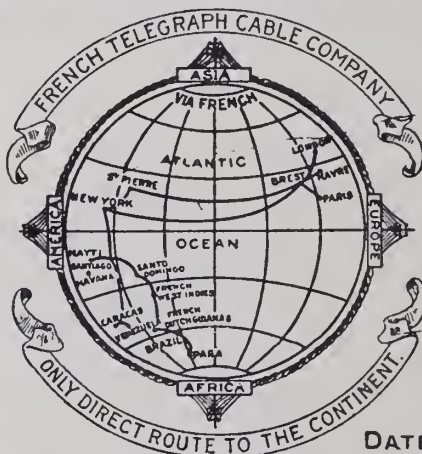

PARIS.

- 38 AVENUE DE L'OPERA
- LONDON.
- 24 ROYAL EXCHANGE, E. C.
- 2 MINING LANE
- HAVRE.
- 40 RUE DE CHILOU,
- BREST.
- 30-32 RUE DE CHATEAU
- ANTWERP.
- AGENCY, 14 RUE VENUL.
- ST. PIERRE, MIQUELON

TIME,

DATE,

MAR 16 1908

The following MESSAGE is received via FRENCH TELEGRAPH CABLE, subject to the terms and conditions printed on the back hereof, which are ratified and agreed to.

B 394 LONDON 20

VEITHOP NY

SYNDICATE FIRMLY INTEND TO MAINTAIN PRICES AS HITHERTO

L AND A ABRAHAMS ON BEHALF OF THE DIAMOND SYNDICATE

Cable and Telegraph addresses registered at telegraph offices in any part of the World are available for the delivery of Cablegrams sent by this line. No inquiry respecting this Message can be attended to without the production of this paper. Repetitions of doubtful words should be obtained through the Company's offices, and not by DIRECT application to the sender.

panies, was recopied over here and interpreted in headlines (and sometimes in the rewriting of the article), as a slump in the prices for the diamonds themselves, a conclusion which was in no way indicated by the reports from London.

As a matter of fact, all who are conversant with the situation knew even before the Syndicate cables were received that the Syndicate has no intention whatsoever of changing the market price for diamonds except in an upward direction, but the newspaper reports caused disquiet among those who did not understand.

Following the despatches from London about the diamond mining company shares came the rumor in the London *Daily Mail*, a British yellow journal, to the effect that the Premier mine might not renew its agreement with the Syndicate. While such a condition is within the range of possibility, inasmuch as negotiations for the renewal of the contract have not been closed, there was nothing particularly new in the suggestion but the inference that followed, namely, that this would mean a fight between the De Beers and the Premier people, had no foundation, in fact, but was purely a speculation on the part of the writer. The American journals, not appreciating the difference in production between the De Beers and the Premier mines, looked upon this as important news, and featured the ac-

count with ridiculous inferences of their own as to a drop in prices.

So it will be seen that out of a stock market story and the fact that the negotiations for a renewal of a contract were still pending, grew up all the sensational erroneous and misleading statements which have appeared in the American and Canadian presses.

THE CIRCULAR-WEEKLY has given the text of the telegrams which appear herewith to the daily press of the country, and has also written letters to the newspapers explaining the situation, and it is possible that many of the papers will now begin and try to undo some of the harm they have done in the jewelry trade through dissemination of this misinformation.

A. Goldman & Co., Pittsburg, Offer Settlement at 25 Per Cent. Which Is Refused.

At a meeting of creditors of A. Goldman & Co., Pittsburg, Pa., held at the Broadway Central Hotel, New York, last Friday, the attorney representing the debtors made an offer of settlement at 25 per cent., which was voted upon and refused. The debtor was not in attendance. His attorney said the firm could not entertain an extension proposition, and that the best they could do was a small offer to creditors.

The assets are claimed to total \$19,267, and consist of merchandise, \$15,267; fixtures, \$1,000, and book accounts, \$3,000. The liabilities are placed at \$16,964. Included in the liabilities is a bank indebtedness of \$3,700, secured by assigned claims, also a loan indebtedness to Rena Fushan (daughter of Morris Gilbert) of \$2,000, secured by assigned claims. These claims held by the bank and Miss Fushan are outside of the book accounts claimed as assets.

The attorney stated in support of the 25-cent offer that in March, 1907, Goldman found himself unable to carry on the business alone and interested Mr. Gilbert, who put \$10,000 cash into the business. He claimed that this money had been expended in salaries, etc., and that all expenditures showed on the books. He stated that between Jan. 1 and Feb. 20, 1908, the debtor had checked out \$13,000 to merchandise creditors and claims to have checks showing such payments. He also said that the debtors had lost about \$3,500 from their book accounts owing to failures.

A committee consisting of H. M. Peck, chairman; Mr. Levy, of Freudenheim Bros. & Levy, A. Frankenstein and Mr. Kelly, of the W. H. Saart Co., were appointed and met the debtor and his attorney at the offices of the W. H. Saart Co. last Saturday, but no better offer of settlement was obtained.

Form No. 1515

WESTERN UNION

Cable Message

WESTERN UNION

THE WESTERN UNION TELEGRAPH COMPANY.

INCORPORATED

ROBERT C. CLOWRY, President and General Manager.

THE LARGEST TELEGRAPH AND CABLE SYSTEM IN EXISTENCE. CABLE SERVICE TO ALL THE WORLD

21,000 OFFICES AND 25,000 ADDITIONAL TELEGRAPH AND TELEPHONE CONNECTIONS IN NORTH AMERICA.

DIRECT AMERICAN CABLES NEW YORK TO GREAT BRITAIN.

CONNECTS also with ANGLO-AMERICAN and DIRECT U. S. ATLANTIC CABLES.

DIRECT COMMUNICATION WITH GERMANY AND FRANCE, CUBA, WEST INDIES, MEXICO and CENTRAL and SOUTH AMERICA— WITH PACIFIC CABLES TO ALASKA, HONOLULU, AUSTRALIA, GUAM, THE PHILIPPINES, JAPAN, ETC.

Branch Offices in Principal Cities of Great Britain and the European Continent. All Foreign Telegraph Stations accept Messages to be sent

"Via WESTERN UNION."

RECEIVED at Central Cable Office, 16 Broad St., New York

TELEPHONE: 2354 RECTOR

MAR 14/08

162CN EXS London 17

VEITHOP NY

PREMIER COMPANY HAVE NO INTENTION LOWERING PRICES

REGARDLESS CONTINUATION OF PRESENT AGREEMENT WITH SYNDICATE

BUSCH FOR THE PREMIER MINING CO

Chester Billings & Son

1840

Successors to
Kandel, Barmore & Billings

1908

Importers of Diamonds
Other Precious Stones, and
Pearls, Diamond Jewelry

1840, Kandel & Barmore; 1866, Kandel, Barmore & Co.; 1880, Kandel, Barmore & Billings; 1897, Chester Billings & Son

New York, 58 Nassau Street, 29 Maiden Lane
London: 22 Holborn Viaduct, E. C. Paris: 53 Rue de Chateaubain
Amsterdam: 2 Tulip Straat

CENTENNIAL TIMERS

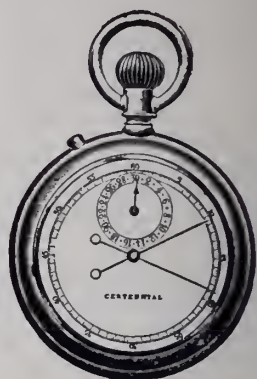

- ☐ Without question the best plain and split second timers made.
- ☐ Register with scientific precision. Substantially built and mechanically perfect.
- ☐ Invaluable for athletic, mechanical and scientific observations. Cased in nickel. Much in demand during the racing season.
- ☐ We also carry split chronographs with minute registers, cased in gold, gold filled and sterling silver.
- ☐ All makes of American cases and movements.



Cross & Beguelin

31 Maiden Lane, N. Y.

Established 1863

Telephone 480 John

GEORGE H. HODENPYL.

WALTER N. WALKER.

HODENPYL & WALKER

IMPORTERS OF

DIAMONDS

OTHER PRECIOUS STONES
AND PEARLS

MANUFACTURERS OF
FINE DIAMOND JEWELRY

373 FIFTH AVENUE, NEW YORK

Corner 35th Street

Telephone, 5093 Madison Square

CHAS. F. WOOD & CO. DIAMONDS

1 MAIDEN LANE - - - NEW YORK

EISENMANN BROS.

IMPORTERS OF

Pearls and Precious Stones

452 Fifth Avenue, New York
cor. 40th St., Knox Building

3 Rue St. Georges, Paris.



Mr. Wolfsheim, of Wolfsheim & Sachs, is now in San Francisco, Cal.

Mr. Wells, of the Waltham Watch Co., is visiting the trade on the Pacific coast.

Jacob Marx, of Kossuth-Marx Jewelry Co., has been in San Francisco, Cal., for several days.

Carl Widemann, representing Borrelli & Vitelli, is in San Francisco, Cal., with a line of coral.

Charles Rednall, with the Alphonse Judis Co., San Francisco, Cal., was, recently, in Sonora, Cal.

William Rapp, with L. A. Giacobbi, San Francisco, Cal., has just left for the northwest mining territory.

W. C. Hough, with Kremenz & Co.'s San Francisco office, has returned from the northwest, and will start late this week for southern California.

Among the traveling representatives in Los Angeles, Cal., recently, were: J. H. Donnelly, Sprochnle & Co.; A. Weilish, George Greensweldt & Co.

T. C. Boylan, Pacific coast representative of Manning, Bowman & Co., has just returned to San Francisco, Cal., after an extensive trip through the north.

The following traveling representatives were in Cleveland, O., during the past week: Frank Otley, Riker Bros.; H. E. Sweet, R. F. Simmons Co.; Harry Bliss, Gorham Co.; Mr. Ayers, Simons Bro. & Co.; Charles Dougherty, Osmer-Dougherty Co.; E. A. Gardner, E. A. Bliss Co.; W. A. Smith and E. C. McKeen, Waltham Watch Co.

Traveling men visiting Boston, Mass., during the week, included: John W. Reddall; E. M. Knapp, J. A. & S. W. Granbery; G. B. Osborn, William Smith & Co.; V. L. Burgess, Kremenz & Co.; E. V. Hutton, H. & E. O. Belais; E. H. Eckfeldt, Eckfeldt & Ackley; Charles Arena, La Scala, Fried & Co.; E. W. Martin, Martin-Copeland Co.; G. W. Read, Larter & Sons; Mr. Spies, Whiting Mfg. Co.; Benjamin Griscom, Bippart, Griscom & Osborn; Louis Nordlinger, L. & M. Kahn & Co.; Frank J. Keller, Keller Mfg. Co.; R. W. Simpson, Jr.; Mr. Kent, Kent & Woodland; J. Schwob, Adolphe Schwob.

The following traveling representatives called on the trade in Kansas City, Mo., during the past week: Jos. Frank, Sussfeld, Lorsch & Co.; H. W. Raymond, Worthington & Raymond; Mr. King, Ostby & Barton Co.; H. A. Scofield, Scofield, Melcher & Scofield; Emil Pick, Hammel, Riglander & Co.; H. G. Pfordresher, Geo. L. Brown & Co.; James O. Otis, Harvey & Otis; Mr. Atkins, New England Watch Co.; R. T. Kleckner, Theodore W. Foster & Bro. Co.; Mr. Kettleby, A. H. Bliss Co.; George B. Neil, Keystone Watch Case Co.; G. A. Armstrong, Paye & Baker Mfg. Co.; Max. L. Jacoby, Manchester Mfg. Co.

The following traveling representatives were in Lancaster, Pa., recently: H. B. Kline, Stott Bros.; Harry Caro, Manchester Mfg. Co.; F. Dilsheimer, Ferd. Dilsheimer & Co.; A. E. Espleman, Adolph Schwob; F. E. Jacobus, Bride & Tinckler; W. H. Rowland, International Silver Co.; Charles Levy, Bristol Mfg. Co.; John D. Rafelye, J. D. Bergen Cut Glass Co.; M. F. Loomis, C. Sydney Smith & Co.; Robert E. Kehl, F. H. Noble & Co.; Sol. Sickles; Howard Claxton, Dennison Mfg. Co.; Mark Scheinman, D. C. Percival & Co.; Mr. Beck, Cheever, Tweedy & Co.; E. P. Ledos, Ledos Mfg. Co.; J. H. Sylva, New Haven Clock Co.

Traveling representatives who called on the Cincinnati, O., trade, during the past week, included: Mr. Sweet, J. F. Sturdy's Sons; Julius F. Schuman, Jr., William Kinschurf Co.; Jos. S. Sideman, Redlich & Co.; H. B. Matthews, Matthews Co.; C. A. Holbrock, Sloan & Co.; J. E. Pryor, Pryor Mfg. Co.; C. Glander, J. D. Dalzell & Co.; George T. Howard, Towle Mfg. Co.; George Taylor, Wilcox & Wagoner Co.; J. T. Griffith, Jr., Carter, Howe & Co.; C. A. Hulstrom, Wilcox & Evertsen; C. L. Krugler, Mandeville, Carrow & Crane; H. A. Scofield, Scofield, Melcher & Scofield; C. E. Pettit, B. A. Ballou & Co.; H. S. Noyes, Bates & Bacon; Mr. Cohen, Levy & Cohen; Frank W. Bloomer, E. I. Franklin & Co.

The following traveling representatives were in Omaha, Nebr., last week: Mr. Clinger, T. G. Hawkes & Co.; Arthur Abraham, Cohn, Abraham & Co.; Thomas E. Rogers, Riker Bros.; Mr. Hartshorn, Kremenz & Co.; Emil Pick, Hammel, Riglander & Co.; T. S. Richter, C. O. Sweet & Son Co.; a representative of Doran, Bagnall & Co.; Theo. Kuehl, Geo. Kuehl & Co.; Charles Jacot, Friedrich Speidel; W. M. Gibbs, J. Hoare & Co.; L. H. Smith, Bippart, Griscom & Osborn; N. D. Batterson, Gillette Sales Co.; Steve Smith, Keller Jewelry Co.; a representative of Hamilton & Hamilton, Jr.; a representative of A. M. Wright & Son; Henry Freund, Henry Freund & Bro.; Thomas H. Ryland, American Watch Case Co.

Imports at the Port of New York.

Weeks Ended March 9, 1907, and March 7, 1908.		
China, Glass and Earthen Ware:	1907.	1908.
China	\$87,058	\$84,940
Earthen ware	8,674	15,721
Glass ware	16,597	37,557
Optical glass	4,777	5,996
Instruments:		
Musical	6,790	23,103
Optical	8,605	5,020
Philosophical	2,300	4,405
Jewelry, etc.:		
Jewelry	18,856	6,611
Precious stones	951,187	77,276
Watches	29,190	23,226
Metals, etc.:		
Bronzes	1,498	132
Cutlery	11,429	26,974
Dutch metal	3,138	2,947
Platina	8,260	36,014
Plated ware		
Silverware	464	512
Miscellaneous:		
Alabaster ornaments	179
Amber	4,365	2,442
Beads	3,715	2,153
Clocks	1,868	2,377
Fans	12,231	4,853
Fancy goods	14,229	8,062
Ivory	37,037	25,743
Ivory, manufactures of	2,824	255
Marble, manufactures of	28,125	13,181
Statuary	5,972	4,838

Bids Solicited by Government Departments to Supply Various Articles.

WASHINGTON, D. C., March 15.—The superintendent of the Treasury Department is inviting proposals until April 15 for the supplies for the fiscal year ending June 30, 1909, and among the items called for are the following:

- Three dozen large thermometers.
- Two dozen small thermometers.

WASHINGTON, D. C., March 16.—The Bureau of Supplies and Accounts, Navy Department, is inviting proposals until March 24 for the following items:

For 6,000 forks for enlisted men—To be of pure white German silver, not less than 18 per cent. nickel, perfectly plain in style, highly polished, and to measure 7 7/16 inches; to weigh not less than 20 ounces avoirdupois to the dozen.

For 6,000 spoons for enlisted men—Same quality as above, to be delivered in neat pasteboard boxes, each to contain two dozen; 6,000 table knives, solid steel, blank, polished.

J. E. Schenck, Bellevue, Ia., has been succeeded by Huntoon & Co.

Thomas Cain was arrested in McKeessport, Pa., about a week ago, accused of selling cheap jewelry without a license. When arraigned in court the accused said he bought the jewelry from a wholesale house in Pittsburg, but was unable to give the name of the firm. He was released upon his promise to leave the city at once.

News Gleanings.

The store of Peter Muller, Perham, Minn., was recently destroyed by fire.

The store of Landhuis & Terpstra, Hoppers, Mo., has been destroyed by fire.

J. F. Hewes, Titusville, Pa., will be compelled to vacate his present quarters, April 1, and has not decided upon his new location as yet.

L. M. Beck, Fort Wayne, Ind., owing to increasing business, has moved to 924 Calhoun St., where he has attractively furnished quarters.

W. J. Lewis, Topeka, Kans., president of the Kansas State Optical Association, has bought the jewelry store of N. F. Morehouse, at that place.

F. Brody & Sons, Des Moines, Ia., will move from the Garver block into their new building, Court Ave., near 4th St., within 30 days.

Cave & Plunkett, Houston, Tex., are fitting up a workshop for the manufacture of jewelry. The new plant will be equipped with every modern mechanical device.

A half-tone illustration, accompanied by a description of the establishment of Walter A. Whitney, Brushton, N. Y., was published in a recent issue of a local daily.

Abraham Marcus, Wilkes-Barre, Pa., and Miss Esther Cohen, of South Pennsylvania, were recently united in marriage. The groom is a well-known jeweler of Wilkes-Barre.

Wm. Schweigert, of Wm. Schweigert & Co., Augusta, Ga., who is the president of the Union Savings Bank of that city, presided at the dinner given to the officers and directors of his bank and the presidents of the other banks of Augusta which was held at the Bon Air recently. Mr. Schweigert had as his guest V. S. Mulford, of the Jewelers' Circular Publishing Co.

At the recent meeting of the stockholders of the Benedict Mfg. Co., East Syracuse, N. Y., officers for the ensuing year were elected, as told in the last issue of THE CIRCULAR—WEEKLY, and dividends were declared of six per cent. on the common stock and seven per cent. on the preferred stock. The new drop presses in the flat ware factory have arrived and have been put in operation.

Charles T. Evans, of the firm of Evans & Sons, Utica, N. Y., has been the recipient of many congratulations from his friends in the jewelry trade as well as many favorable comments from newspapers upon the publication, in book form, of the collection of his essays on the jewelry trade subjects which have appeared from time to time. The book appears under the title of "Evans' Essays; or, Practical Hints to Retail Jewelers by One of Them."

The Treasury Department has acquiesced in the recent decision of the United States Circuit Court of Appeals against the government's contention that the statue *La Bellona* of ivory and bronze, imported by Tiffany & Co., was dutiable at 35 per cent., the Court holding that the importers claim that it was dutiable at 15 per cent. was correct, and that the paragraph for statuary does not require that it should be produced in a solid block or mass. The case is now closed.

ADDISON W. WOODHULL, President.
FRANK K. HUFF, Vice-President.

GILBERT T. WOODHULL, Treasurer.
WILLIAM J. McQUILLIN, Secretary.

MOUNT & WOODHULL,

IMPORTERS OF **DIAMONDS,**
OTHER PRECIOUS STONES,
PEARLS, ETC.

MAKERS OF
FINE
DIAMOND
JEWELRY.

26 Maiden Lane,
(Southwest Corner Nassau Street)

NEW YORK

EMERALDS, DIAMONDS AND PEARLS

BAGG & CO.
Successors to BAGG, PERINE & CO.
IMPORTERS
452 FIFTH AVENUE, at 40th Street
NEW YORK

CABLE ADDRESS: MILBAGG

TELEPHONE NUMBERS: 917-918 BRYANT

RUBIES AND SAPPHIRES

Pearl Necklaces and Collarettes.

Mounted Diamond Jewelry
of every description.



Emil W. Ruffer
John W. Ruffer
Frank L. Wood

Largest assortment of all kinds of very fine, fancy and rare gems, including Pearls, Diamonds, Rubies, Emeralds and Sapphires.

Particularly Fancy Colored and Fancy Shaped Diamonds:

182 & 184 BROADWAY
NEW YORK



Edward Willis is a new jeweler at Hollywood, Cal.

E. Mueller will shortly open an optical store in Eureka, Cal.

Thomas H. Avery has started in the jewelry business at Owendale, Mich.

Noble & Hunt, Newark, N. J., have been incorporated, with a capital stock of \$50,000.

John Ramage recently opened a repair shop at 552 W. Prospect St., Hollywood, Cal.

W. S. Brady is about to open a watch and jewelry repairing establishment in Broxton, Ga.

A. Dannanbawn, New York, about April 1, will open a retail jewelry store in Mahanoy City, Pa.

C. H. Linneman & Son expect to open a large manufacturing plant in San Francisco, Cal., in the near future.

Philip Klein has gone into the wholesale jewelry business in San Francisco, Cal. His store is located on 4th St.

A Mr. Frigault has completed arrangements to open a repairing establishment in the Gifford block, Mayville, N. Y.

Norris L. Berry, formerly with J. J. Woodward, Somersworth, N. H., has opened a retail jewelry store in Limerick, Me.

Denny & Ellington is the name of a new retail jewelry concern which was recently organized in Greensboro, N. C. The store is located on Elm St.

The Z. F. Highsmith Co. has been incorporated in Sumter, S. C., with a capital stock of \$25,000, to engage in the manufacture of jewelers' tools.

Edward G. Koelser has gone into the jewelry manufacturing business, with quarters in the Hodges building, Detroit, Mich. He was formerly employed as a repairer by Hugh Connelly, of the same place.

The Julius Friton Jewelry & Gem Co. filed articles of incorporation, last week, with the Secretary of State, at Jefferson City, Mo. The capital stock is \$14,000, all paid. The incorporators are: Julius Friton, 138 shares; Julius G. Friton and Albert G. Rubin, Jr., one share each.

Jewelers' Gold Bars Withdrawn and Exchanged at New York.

Week Ended March 14, 1908.

The U. S. Assay Office reports:
Gold bars exchanged for gold coin.....\$206,798.46
Gold bars paid depositors..... 62,568.70

Total\$269,367.16

Of this the gold bars exchanged for gold coin are reported as follows:

March 9.....	\$61,711.94
" 10.....	10,321.48
" 11.....	72,432.53
" 12.....	41,614.20
" 13.....
" 14.....	20,508.31

Total\$206,798.46

New Orleans, La.

TRADE CONDITIONS.

The Mardi Gras has come and gone, and the city has doffed its holiday attire and enters its every-day routine. The event is always looked forward to by jewelers with pleasure as the great influx of strangers always stimulates business, and in the jewelry trade particularly. Though the number of visitors was more than usual this year, the local trade did not do any better than last, though a large number of the dealers benefited to a considerable extent. This is due to the fact that the visitors did not spend money as freely as heretofore, but of what they did spend, the jewelry trade got its full share.

The entire traveling force of Leonard Krower, which was in the city during the arrival to entertain the customers of the firm, are now preparing to resume their regular duties.

Among the most beautiful show windows of the carnival were those of the old firm of A. B. Griswold & Co., 728 Canal St. One window had in it a huge wooden watch 12 feet in circumference, literally covered with watch movements all going, the movements being the product of the Illinois Watch factory.

Among the out-of-town jewelers who have been in this city recently were: J. Lowe, Carl Goepel, F. C. Rivoire, H. Hollins, A. Hollins, S. J. Rivoire, Mr. Bartlett, of Sherwood & Bartlett; H. Chachere, F. J. Dreher, Ben Peine, A. Simon, A. J. Mashaw, Foreman Parker, P. E. Villiminot, H. F. Meilleur, R. E. Currer and C. A. Goepel.

The displays made by the jewelers of this city during the Mardi Gras were unusually handsome this year, but owing to the recent epidemic of robberies extra precautions were taken during crowded times to prevent thefts, and these seem to have been successful, as so far no window robberies were reported, nor did any member of the trade sustain loss during the festivities.

The second convention of the Louisiana State Optical Society, which was held here recently, was well attended and proved satisfactory in every way. Many lectures were delivered, among them a demonstration of frame fitting by J. Beck, a demonstration of the manufacture of lenses by E. G. Bohne and an address on "How to Handle a Customer," by Charles Claremont. During the convention Leonard Krower presented the visitors with a box of cigars.

Rochester.

Jewelers of this city were interested in the news from Waterloo, received last week, to the effect that the suit brought by the Eldorado Jewelry Co., of Iowa, against Graham & Selmsler, a Waterloo firm, to recover \$197.70 for cheap jewelry sold the defendants, had been unsuccessful. The defendant firm returned the jewelry as unsatisfactory and the Iowa firm brought suit. When the case was tried the judge ordered a verdict for the defendants.

A thief recently robbed the window of the jewelry store of S. D. Burritt, 104 State St., and got away with articles valued at \$100. With a glass cutter he made a hole in the plate glass large enough to insert his arm and took everything within reach. Shortly after the robbery was discovered, a man who says he is Charles Keeler, 32 years old, was arrested while selling jewelry, and some of

the articles found on him were identified as the stolen property. The police say he confessed having committed the act. Later George Rice, 28 years old, was arrested on the charge of receiving some of the articles.

St. Louis.

A. Kurtzeborn, Jr., has opened an attractively furnished establishment in the Frisco building, this city. Mr. Kurtzeborn was for a long time associated with the firm of A. Kurtzeborn & Sons.

The motion of Pierce's Loan Co. to have Mrs. Mary Killian removed as the administratrix of her husband's estate was denied, last week, by Probate Judge Holtcamp. The company appealed to the circuit court with a claim for \$620 for diamonds, said to have been bought by Killian, which claim was disallowed. R. Lee Killian was a city detective, who was shot and killed, about a year ago. After his death suit was brought against his widow for some diamonds included in his estate which she claimed she had loaned to him. The suit of the loan company is an outgrowth of the other action.

Wheeling, W. Va.

T. A. Westmyer recently presented the local Board of Trade with a handsome clock.

The Phillips Jewelry Co. has purchased the cases and fixtures of Charles Hancher's old store in this city, which will be completely remodeled for future use.

The building at 1314 Market St. was recently renovated and opened by the Wheeling Optical Co. S. C. Cozard, formerly of the West Virginia Optical Co., is in charge.

George Wolf, John Cox and Ellsworth Cox were arrested last week by the local police, and are believed to have been connected with the robbery of Joe Nessen's jewelry and cigar store, which took place March 15. A watch and some rings found on the prisoners are claimed by Nessen.

Buffalo, N. Y.

The fifth annual meeting of the Buffalo Optometrical Society was held recently in the Lafayette Hotel and the following officers were chosen for the ensuing year: President, L. W. Aldridge; vice-president, E. G. Wiseman; secretary, Julius Hansen; treasurer, R. T. Williams; executive committee, E. V. Syrcer and C. F. Cushing.

A recent issue of the Buffalo News contained an interview of E. J. Eisele, of King & Eisele, on the subject of the bill to regulate the marking of watch cases introduced by Congressman Vreeland. Mr. Eisele criticized the bill and suggested amendments which he claimed would improve its effectiveness and make it more satisfactory.

A note in the last issue of THE CIRCULAR-WEEKLY mentioned the fact that T. G. Hightower obtained a verdict against W. L. Davids, Troy, Ala., for \$750, on a charge of false arrest. The impression conveyed by this note, however, was erroneous, inasmuch as we learn from Mr. Davids that the judge before whom the case was tried set aside the verdict as being not in accordance with the evidence in the case.

Last Week's New York Arrivals.

THE CIRCULAR-WEEKLY each day posts in its office a bulletin of the latest buyers visiting New York, which every member of the trade is cordially invited to copy.

- ALBANY, N. Y., M. Levitz, Astor House.
- BALTIMORE, MD., J. W. Putts (J. W. Putts Co.), Albert.
- W. E. Putts (J. W. Putts Co.), Albert.
- BOSTON, MASS., J. M. Bacon, Astor House.
- J. B. Humphrey (J. B. Humphrey Co.), Algonquin.
- BRIDGEPORT, CONN., J. C. Mizer (Howland Dry Goods Co.), 454 Broome St.
- BRATTLEBORO, VT., G. H. Clapp (A. B. Clapp & Bro.), Ashland.
- BUFFALO, N. Y., F. Meyers (Adams, Meldrum & Anderson Co.), 2 Walker St.
- P. C. Schaeffer (Adams, Meldrum & Anderson Co.), 2 Walker St.
- C. F. Damm, Astor House.
- CLEVELAND, O., C. E. Myers (The Fries & Schule Co.), Brozteil.
- DES MOINES, IA., M. Joseph (S. Joseph & Sons), 622 W. 137th St.
- ELK POINT, S. DAK., H. Pinkin (C. Holain), Grand Union.
- HAMMOND, IND., C. Arkin, Cosmopolitan.
- MINNEAPOLIS, MINN., F. H. Weld (Weld & Sons), Navarre.
- PHILADELPHIA, PA., R. Quinn (John Wanamaker), Broadway and 10th St.
- SIENANDAOHI, PA., S. Levit, Broadway Central.
- SPRINGFIELD, MASS., D. Wallace (Forbes & Wallace), 2 Walker St.
- WASHINGTON, D. C., Mrs. J. C. Nourse (Woodward & Lothrop), Holland; 438 Broadway.

Newark.

L. F. Hersh & Bro. have purchased the building 130 and 132 Broad St., Elizabeth, N. J., in which are located Otto Roggenkamp's store and the drug store of Oliver & Drake. They intend to remodel the building for office purposes.

After being established in business in Elizabeth, N. J., continuously for seven years, the Maiden Lane Diamond, Watch & Jewelry Co., 219 Broad St., will retire from business at the end of this month. The clearing sale began Wednesday last and will continue daily at 2.30 to 7.30 P. M., until the stock is disposed of. James L. Hand, Jr., is the auctioneer in charge of the sale.

Israel Solomon, a jewelry peddler from New York, was arraigned in a Paterson (N. J.) police court recently on a charge of peddling without a license, preferred by Warrant Officer Cervino and fined \$25 by the recorder. The prisoner had only \$18 in his pockets and wished to telephone to his brother-in-law to have him come up with the money, but the court officer requested the man to sit down and refused to let him telephone and he was committed for 30 days.

The plot on the northeast corner of Austin and Parkhurst Sts., 130x85, was sold last week to Larter & Sons, manufacturing jewelers. The ground was in two plots, one belonging to Emil C. Mertz, and the other to W. S. Righter. The consideration was not given, but it is understood to be in the neighborhood of \$12,000. The jewelry firm expects to erect during the summer a modern building to suit the purposes of the business. The building will be fireproof and will be used entirely by the firm.

WM. S. HEDGES & CO.,

IMPORTERS AND CUTTERS OF

DIAMONDS.

Precious Stones and Pearls.

170 Broadway, Corner Maiden Lane, New York.

27 Holborn Viaduct, London.

RUBIES

BURMAH, SIAM AND SPINEL

SAUNDERS, MEURER & Co.

65 NASSAU STREET

NEW YORK

STERN BROS. & CO.,

CUTTERS OF

DIAMONDS,

CUTTING WORKS:

138-142 West 14th St., N. Y.

68 Nassau St.,

NEW YORK.

CHICAGO,
103 State Street.

LONDON,
29 Ely Place.

HIRSH & HYMAN,

IMPORTERS AND CUTTERS OF



2 MAIDEN LANE, NEW YORK

Broadway-Maiden Lane Building

DIAMONDS

TRY
US ON

Lissauer & Company
IMPORTERS

52-54 MAIDEN LANE, NEW YORK

Cleveland.

Webb C. Ball was in Chicago Thursday. L. J. Goddard, of Ravenna, was in this city last week.

J. H. Heiman was out of town several days last week.

Harry Goldberg spent part of last week in New York conferring with creditors.

W. H. Rees and F. R. Gee, of the Wingate, Nusbaum Co., spent the past week in New York.

Henry Horowitz has purchased his partner's interest and will continue the business of Horowitz & Checel.

The Franklin Jewelry Co., owned by Chas. Ettinger, is conducting and extensively advertising an auction sale. Their displays advertise that fixtures and lease are for sale.

T. J. Schauweker, of Schauweker Bros. Co., is a member of the Cleveland Grays, a local military organization of national reputation. He has just returned from a two weeks' trip with them through the South to Havana, Cuba.

While Samuel Kleiman, 2546 E. 55th St., was away Friday morning, bold daylight burglars broke into his place with duplicate keys and stole a small basket full of jewelry. A gold watch set with a diamond in the back, a gold rope chain with locket, a gold ring set with rubies, one set with a turquoise, one set with four opals, and a band wedding ring, also a bracelet and a locket were among the booty.

B. V. Arnstine and H. W. Arnstine, of the Arnstine Bros. Co., are getting ready to call on their numerous customers in various States, to arrange with them for again placing the usual orders for their holiday catalogues. J. Y. Wells, formerly with a St. Louis, Mo., house, is now representing the Arnstine firm in the northwestern States, and C. H. Van Pelt, recently connected with one of the largest eastern diamond importing houses in the northeastern States.

With the intention of according all creditors equal consideration, the Henry Welf Co., conducting a jewelry store on Euclid Ave., made an assignment March 9 in Judge Adams' Insolvency Court. Edw. W. Dissette is named as assignee under a bond of \$3,000. Appraisers are now at work on the stock, which will inventory at about \$3,000, as against \$2,200 of merchandise liabilities. The Welfs have been particularly unfortunate in undertaking to "pioneer" in a slowly developing business section—they were delayed many months in getting into their new location and have been hindered ever since by building operations and obstructions in the neighborhood, which have made it difficult for customers to reach them. Attorney Wm. M. Reynolds, representing the Welf Co., advises that matters will be wound up for the benefit of the creditors as expeditiously as possible and with the sole idea of meeting an unfortunate situation in an honorable manner.

The Lazarus Jewelry Store, Macon, Ga. is adding new fixtures of solid mahogany plate glass and marble and making other extensive improvements in the interior of its establishment.

Connecticut.

C. D. Morris, Wallingford, was called to Waterbury on jury duty, last Thursday.

C. H. Tibbitts, Wallingford, left on Tuesday of last week, for a 10 days' business trip to the south.

Factory "M," International Silver Co., Wallingford, is now running on a five-day per week schedule.

Charles D. Benker has succeeded Herman Michaelis as foreman of the lamp department of the Bradley & Hubbard Mfg. Co., Meriden.

A. Frank, Bridgeport, has engaged in the pawn brokerage business, which he will conduct in conjunction with his jewelry and optical business at 233 State St.

George H. Undorf, for some time an employe of the movement department of the Seth Thomas Clock Co., Thomaston, died recently at that place, aged 31 years.

Edward S. Dwight, a jeweler of East Hartford, was recently found dead at his home. Death was caused by heart disease. The deceased, who was 55 years old, is survived by a widow and one son.

L. V. B. Hubbard and wife, Shelton, last week celebrated their golden wedding anniversary. Mr. Hubbard has been engaged in the jewelry business at that place for several years.

Morris S. Cramer, a clockmaker by trade, having been employed for several years by the New Haven Clock Co., New Haven, died, about a week ago, at his residence at that place, aged 73 years.

Samuel W. Tasch was one of the reception committee of three for the Wooster Lodge, Knights of Pythias, Danbury, which welcomed the grand officers of the order to a banquet held in Danbury, March 12.

Joseph Bauer, of New York, who is accused of having stolen several diamonds from the store of Parker, Kolb & Co., Bridgeport, was brought to that city from New York about a week ago, and arraigned in the city court. His case was continued.

Henry Schaw, employed as a bellboy at the Allen House, Hartford, was arrested Wednesday afternoon on a charge of the attempted theft of \$1,000 worth of jewelry belonging to Charles Murphy, a traveling representative for a New York jewelry concern.

Frank A. Wallace, president of R. Wallace & Sons Mfg. Co., and of the First National Bank, Wallingford, sailed recently for a six weeks' trip to Europe. He will pass some time in London with friends and will then proceed to Germany, France and Russia.

Wm. Forbes was arrested, one day last week, on George St., New Haven, accused of burglary. Among the stores which Forbes is alleged to have robbed is that of a jeweler named Falco, 172 Meadow St. An accomplice, named Wm. Shaw, is the nephew of the jeweler whose store was looted.

At the recent annual meeting of the Wallingford Co., Inc., the following directors and officers were elected: Directors, C. W. Leavenworth, F. A. Wallace, F. W. Morris, C. D. Morris and Henry Norton. President, C. W. Wallace; secretary and treasurer, C. D. Morris; manager, Henry Norton.

Max J. Buechler, Bridgeport, has secured a lease of a large store in the Windsor Hotel building, for five years, at an annual rental of \$1,800, with the exception of the first year when the rental will be \$300 less. There is a provision for a renewal at the expiration of the lease if notice is given before March 1912.

Lancaster, Pa.

TRADE CONDITIONS.

Business here during the past week took a distinctive turn for the better, and most of the jewelers felt an improvement in trade. Lancaster county's big crop of tobacco is now selling rapidly, and as it is paid for as soon as delivered, a big lot of money is already beginning to circulate. It is believed by the trade that better times are at hand.

Monroe B. Kersey has gone to Charleston, S. C., on a two weeks' trip.

T. R. Helms, a jeweler of Hamlet, N. C., spent part of last week in Lancaster with friends.

John J. Bowman, of Ezra F. Bowman's Sons, has been in Philadelphia and parts of New Jersey.

Miss Carrie A. Sanders, for some years connected with the Hamilton Watch Co., died March 11.

P. J. Broomell, Wichita, Kans., stopped over in Lancaster a few days last week en route to New York.

H. N. Gurley, a Johnstown, Pa., jeweler, formerly of Lancaster, sustained a serious loss last week by fire in his store.

H. E. Sanders, a retired jeweler living near Marietta, had a stroke of paralysis Thursday and is in a serious condition.

G. William Reisner has just completed a number of solid gold pins for the senior class of the High School of Helena, Mont.

Louis Weber & Son have placed on the front of their building a handsome electric sign, 15 feet long, which attracts much attention.

Giuseppe Platona, a silversmith of Rome, Italy, spent last week in Lancaster, visiting relatives. He intends traveling extensively in the south before returning home.

Louis Weber & Son and S. Kurtz Zook furnished some pretty prizes for the big euchre held on the evening of March 10 by Conestoga Council, Royal Arcanum.

Charles Weidner, an engraver, formerly with Carter, Howe & Co., New York, has taken a position with a Lancaster leaf tobacco dealer as a traveling salesman.

A. W. Moyer, manager of the Non-Retailing Co., visited Baltimore and Washington last week. E. R. Kant, a representative of the company, is off on a trip to western Pennsylvania, Maryland and Virginia.

George Folckner, Shrewsbury, Pa., who was home on the sick list a month, has returned to the technical school, where he is a student. Roy Lefever, of Sharon, Pa., has entered the school as a student in watchmaking.

Among the out-of-town jewelers here recently were Clarence Halbach and E. L. Rinckenbach, Harrisburg; Jerome J. Butler, Chicago; M. M. Finckabine, Wheeling; Carson T. Dodd, Memphis, Tenn.; Allan Carter, Boston.

C. K. Rothstein, Bradford, Pa., has sold out and moved to Cambridge Springs for the benefit of his health.

Boston.

Carl D. Smith, of the Smith, Patterson Co., is on a recreation trip to Atlantic City.

The Waltham Watch Co. recently increased the working time of its factory seven hours a week.

Bernard Alberts, after being away nearly a year, has returned to his old position of assistant manager of the United Jewelry Co., 749 Washington St.

George R. Nutter, of this city, has registered at the Massachusetts State house as a legislative agent to attend and speak at all hearings bearing on the proposed bill for the registration and licensing of opticians.

Edward Barlow, who was for a number of years with the Shreve, Crump & Low Co., and more recently with the Smith, Patterson Co., in the stationery department, has returned to the employ of the former concern.

There was a good attendance of members of the New England Watchmakers' Club last Wednesday evening, when a talk upon the adjusting of watches was given by J. A. Freund, of New York. To-night the annual meeting will take place, and officers will be elected for the year.

One of the large plate glass front windows of the jewelry store of John C. Sawyer, on Summer St., was broken Tuesday night, March 10, but it is supposed that the would-be robbers were frightened away, as nothing had been taken when the break was discovered and the police were notified.

Boston dealers in diamonds have received from one of the largest diamond cutting firms in the world, having workshops in New York, Antwerp and Amsterdam, the following announcement: "We and all other cutters have received the following cable: 'Premier has no intention of lowering prices regardless of condition. Present agreement with syndicate signed.'" This is accepted here as reassuring the dealers in the matter of diamond prices, and will be an argument for maintaining quotations to customers.

Pacific Northwest.

H. A. Miller, North Bend, Ore., has sold out to L. Barr, who has already taken possession.

Burglars broke into the store of Geo. Schwartz, 613½ Second Ave., Seattle, Wash., recently, and escaped with \$350 worth of stock.

Ralph Winslow, of Winslow Bros., Pendleton, Ore., was on board the Sheridan local that was wrecked near Forest Grove, recently, and sustained a badly injured knee.

Fred C. Grover, Snohomish, Wash., has filed a voluntary petition in bankruptcy in the Federal Court, giving his debts as \$4,860 and his assets, including his home and furniture, which he asks to be classed as exempt, as \$5,760.

The bankrupt stock of the Orland M. Heacock store in La Grande, Ore., has been sold by Frank Phy, the trustee, to the La Grande Investment Co. for \$3,000. The liabilities are placed at \$11,000, and as some of the items are preferred claims it is estimated that most of the creditors will not realize more than 20 cents on the dollar.

MONTANA SAPPHIRES

AT ATTRACTIVE PRICES

Where uniformity of size, evenness of color and quality are essential, our stock of Montana Sapphires particularly commends itself.

Pearls and practically every precious and semi-precious stone but the diamond.

BUY FROM THE CUTTERS

AMERICAN GEM & PEARL COMPANY

14 & 16 CHURCH STREET, NEW YORK

London, 16 Holborn Viaduct

Paris, 39 Rue de Chateaudun

FROM MINES TO MARKET

Canada Notes.

The assets of A. Mongeau & Co., Montreal, who recently assigned, were scheduled to be sold March 13.

Harry Smith, with Ryrie Bros., Toronto, Ont., has returned from an extended purchasing trip to New York and the eastern markets. A. E. Elmes, representing the same firm, is back from a buying trip.

Out-of-town jewelers calling on the Toronto, Ont., trade, last week, included: F. J. Brown, Galt; W. H. Smith, Oakville; T. C. Watson, Newmarket, and E. G. McLaren and J. B. Nash, representing W. G. Young, London—all Ontario.

On Tuesday, March 10, Sir Richard Cartwright, on behalf of the Canadian government, introduced into the Dominion Senate a bill postponing for one year the date set for the Gold and Silver Marking Act to come into force. This will permit of the consideration at the present session of the proposed amendments agreed upon by a joint committee.

Edward Jones, aged 21, and his brother, Roy Jones, aged 23, were arrested last week in Buffalo, N. Y., on request of the Hamilton, Ont., police, charged with entering Mr. Levy's jewelry store, 55 John St., Hamilton, and stealing about \$500 worth of watches, rings and other goods. Most of the goods were recovered. The prisoners refused to return to be tried for robbery in Canada and were sent to jail for 90 days each on the charge of bringing stolen property into the United States.

Harrisburg, Pa.

Joseph Rinkenbach, son of E. L. Rinkenbach, is perfecting himself in his knowledge of optometry in New York.

Harrisburg jewelers and other merchants have been asked by Senator Penrose for an expression of their opinion concerning the proposed parcels post law.

The country sale season is now on and grandfathers' clocks are being sought. At a recent sale near here one of these old relics was purchased for \$90. They are invariably good timekeepers.

Uptown jewelers are jubilant over the action of Select Council in adopting an amendment to the traction extension ordinance requiring the railway company to operate cars both ways on N. 3d St.

The store of David Smith, 227 Christian St., Steelton, was entered last week by burglars who carried away a quantity of merchandise, including a number of suit-pins. A panel was cut from a back door.

The handsomely embroidered city flag just received from the American Flag Co has been on exhibition in the jewelry store of C. Ross Boas on Market St. It is a beautiful emblem containing a reproduction of the dome of the State Capitol flanked by the coat-of-arms of the Dauphin of France, and is attracting much attention.

The three former State officials, Messrs. Mathues, Snyder and Shoemaker, and Capitol Contractor John H. Sanderson were convicted March 13 of conspiracy to defraud the State out of considerable money in the matter of furnishing the new \$13,000,000 State Capitol. New trials will be asked, the defendants renewing their bail.

CORAL

All Kinds of Coral Specialties for Jewelers

DROPS
BUTTONS
LENTILLES

CORAL
NECK-
LACES

All Shades
and Sizes

Graduated and
Uniform



CORAL MANUFACTURING COMPANY

CORAL

Extra Rose
CORAL
A Specialty

Gold Medal
St. Louis, 1904

Grand Prix
Liege, 1905

BORRELLI & VITELLI

3 Via Amedeo,
Terre del Greco Italy

401 Broadway, New York
Telephone, 5412 Franklin.

19 Rue d'Hauteville,
Paris, France

Tel. 4457 } Cort.
4458 }

JOHN M. RICHARD 2 MAIDEN LANE
Room 302. NEW YORK

American Pearls and Baroques

MATCHED PAIRS FOR EARRINGS

The Largest and Finest Assortment in the Market, Mounted and Unmounted.

Attleboro.

Frank H. Sadler, of F. H. Sadler & Co., enjoying a brief rest at The Breakers, Palm Beach, Fla.

Charles H. Eden, of the C. H. Eden Co., defendant in a \$2,000 damage suit, the result of an auto collision in 1906.

Alfred D. Crosby has withdrawn from J. Cummings & Co. He is reported as contemplating entering business for himself.

Edward Richardson, the Providence manufacturer, has the sympathy of the trade in the death of his father, Edward O. Richardson, in this town, last week.

John M. Fisher, of J. M. Fisher & Co., is at present the favored candidate for delegate from this congressional district to the prohibition party convention in Columbus, July 15.

Charles M. Robbins, of the Chas. M. Robbins Co., is en route home from Honolulu. On the way he will show samples through the west. He is expected home the last of April.

Albert Winsor, a retired manufacturer, is now a patient in a hospital in Providence, and was kindly remembered on his birthday, last week, with fruit and flowers from Masonic associates.

The manufacturing jewelers, who contemplated forming a social and trade club, with headquarters in a handsome building on North Main St., have dropped the matter for the present.

P. T. White, of Otto Young & Co., Chicago, in charge of his concern's buying and catalogue departments, was a visitor at local factories last week. He expressed agreeable surprise at the municipal improvements since his last previous visit in 1890.

Frank Mossberg, of the Frank Mossberg Co., paid a business visit to Quebec, last week. He is contemplating a branch factory there or in Montreal, but so far has not considered devoting it to any of his lines, which affect the jewelry industry.

"I expect to see the jewelry business pick up noticeably after May 1," is the declaration of Charles A. Marsh, of C. A. Marsh & Co. Mr. Marsh takes a decidedly optimistic view of the situation, in spite of the fact that at present business is greatly curtailed.

In the Superior Court the cases of Mauran I. Furbish and Herbert B. Robinson vs. the B. K. Mfg. Co., were, last week, settled after a portion of the evidence had been heard. The suits were to recover on notes of \$1,200 each given at the time the concern was incorporated.

Charles O. Sweet, of C. O. Sweet, Son & Co., head of the work committee for unemployed, has called for \$250 of the \$1,000 relief fund for immediate distribution. The number registering as in want of work has been large enough to keep the selectmen's office open after hours, and a few have in this way found temporary work.

Factory Supt. Wood, of the James E. Blake Co., whose resignation was noted two weeks ago, will take a position in Providence shortly. He has been succeeded by the promotion of Asst. Supt. Fitch, who entered the employ of the company nine years ago, and has worked up to a post calling for real executive ability. Mr.

Wood will shortly remove his household to Providence from South Main St., this town.

Joseph L. Sweet, of the R. F. Simmons Co., sailed, last Thursday, for a trip to Italy, Austria, Germany and England. The work of salvaging the temporarily wrecked Jewelers' Bank of North Attleboro, fell heavily on his shoulders at a time when he was not physically ready for it, and now that the work has reached a point where he can be spared, his doctor has ordered him abroad. He will return about April 15, the trip being principally for the voyage.

Col. Sidney O. Bigney, of S. O. Bigney & Co., made, last week, a public utterance which was by far the most hopeful thing heard from a manufacturing jeweler around here for months. He was one of the guests of honor at a banquet given by the Brockton (Mass.) Republican Club, and in his post-prandial address said: "I confidently predict that the jewelry business will be on the boom again by fall. The Attleboro manufacturers are going to send out the largest and best lines in their history. Nobody ever made business good by sitting at home and whining. We are going to get out a lot of new goods, so good they'll have to buy them; we're going to try and cheer the other fellow up and get him busy again, and the wheels will have to move." Mr. Bigney is in the midst of a whirlwind campaign for the honor of being one of the four State delegates-at-large to the Republican National Convention, and it is calling for a hard fight, demanding his personal attention from the tip of Cape Cod to the Berkshires.

A syndicate of New York men is negotiating for the purchase of the holdings in this town of Charles H. Tappan, head of the D. F. Briggs Co. If this is carried through successfully, it will be by far the most epochal change in the history of the jewelry industry here. The public has been taken very little into the confidence of the negotiators up to this time, but it is possible to state that an offer has been made and is under consideration. Meantime Mr. Tappan is in Chicago, and cannot be interviewed. The reason for the sale being contemplated at this time is the low state of Mr. Tappan's health, which makes him anxious to drop the heavy burden now on his shoulders. He is at a private hospital in the suburbs of Chicago, undergoing treatment, which has seemed to show some good effects. Arduous work and the shock of the recent sudden death of his brother, William C. Tappan, have made retirement seem desirable. The business is extremely prosperous and has never been openly offered for sale, but it has been understood that a practical offer would be considered. If a sale is made, it is understood that Mr. Tappan desires to dispose of his entire holdings *en bloc* rather than piecemeal. He is head of the D. F. Briggs Co., has controlling interest in Bates & Bacon, and on the death of Joseph M. Bates not long ago purchased the numerous jewelry factory buildings erected by the latter. He is at present the central figure in the industry in this town, and if he sells out and retires will be greatly missed. In his present illness he has the sympathy of a wide circle of friends and associates.

North Attleboro.

Alton H. Riley has purchased a new automobile.

George K. Webster has gone south for three weeks.

R. Abrams, New York, was in town the latter part of last week.

S. E. L. Coombs is in Maine on a business trip for Paye & Baker Mfg. Co.

R. H. Booth, salesman for Sturtevant & Whiting, was in town the past week.

Mr. and Mrs. E. A. Roser, Chicago, announce the engagement of their daughter, Miss Helen Caroline Roser, to Roy C. MacPherson, who covers the middle west for Riley & French.

Robinson Bros. will move from the third story in the Plainville Stock Co. building to the quarters formerly occupied by Maintien Bros. & Elliot, in the building with Scofield, Melcher & Scofield.

Earle Middleton, a watch repairer, was badly burned last Wednesday afternoon while working at the bench with a small flame. A few feet away was a small dish of benzine, and the vapor from the liquid ignited, setting the benzine ablaze. Seizing the dish Mr. Middleton placed it on the floor and sought to extinguish the flames, which soon spread to a large pile of newspapers.

The application of the petitioners for a charter for the Manufacturers' National Bank was favorably acted upon by Comptroller of Currency. March 10 the formal election of directors took place, G. K. Webster, Joseph L. Sweet, Frederick E. Sturdy, F. L. Baker, Albert Totten, G. Herbert French and Andrew E. Jencks being selected. Fred E. Sturdy was chosen president and Clifton W. Carpenter, paying teller at the Jewelers' Bank, was chosen cashier. The bank expects to open in two weeks.

Atlanta, Ga.

Meunch & Beiersdorfer, 99 Peachtree St., have on exhibition in their window a beautiful silver cup handsomely embossed, about 15 inches high on ebony base, that will be given to the member of the Atlanta team making the best batting average. The member of the team playing in 50 games or more and making the most hits will receive this beautiful piece of silver.

Accompanied by Chief of Police Mallory Bousch, of Norfolk, Va., H. B. Jones, an expert watchmaker and jeweler of this city, is in New Orleans for the purpose of determining if possible whether the diamond ring pawned by one T. C. Felkner is the jewel taken from the body of Mr. Berry at Norfolk, Va. Last November A. H. Berry, a traveling salesman living at Rome, Ga., was found dead in his room at a hotel at Norfolk. All of his jewels were gone, and it was supposed that he had been killed and robbed. Efforts were made to apprehend the murderer, but no clew was obtained until some time in January, when a diamond ring was pawned in New Orleans to a former Rome citizen, who recognized the jewel as one owned by Berry. The man, whose name was T. C. Felkner, was placed under arrest, and now efforts are being made to ascertain if he is responsible for the death of Berry.

EICHBERG & CO.,

IMPORTERS AND CUTTERS OF

DIAMONDS,

65 NASSAU STREET, (Prescott Building.) NEW YORK.

A. ROSEMAN, 9-11-13 Maiden Lane, New York

IMPORTER OF

DIAMONDS

Maker of Diamond Jewelry



TRADE-MARK.

Established 1872

HEADQUARTERS FOR

AMERICAN WATCHES

"There is Nothing in the Art that we cannot do."

Special Attention

GIVEN TO OUT OF TOWN ORDERS

The International Gem Co., Inc.

12-16 JOHN ST., NEW YORK

TELEPHONE 1241 CORTLAND

Lapidaries and Importers of Precious Stones

SPECIALISTS IN REPAIRING AND REPOLISHING RARE AND VALUABLE GEMS
DRILLING—ENGRAVING—SLITTING

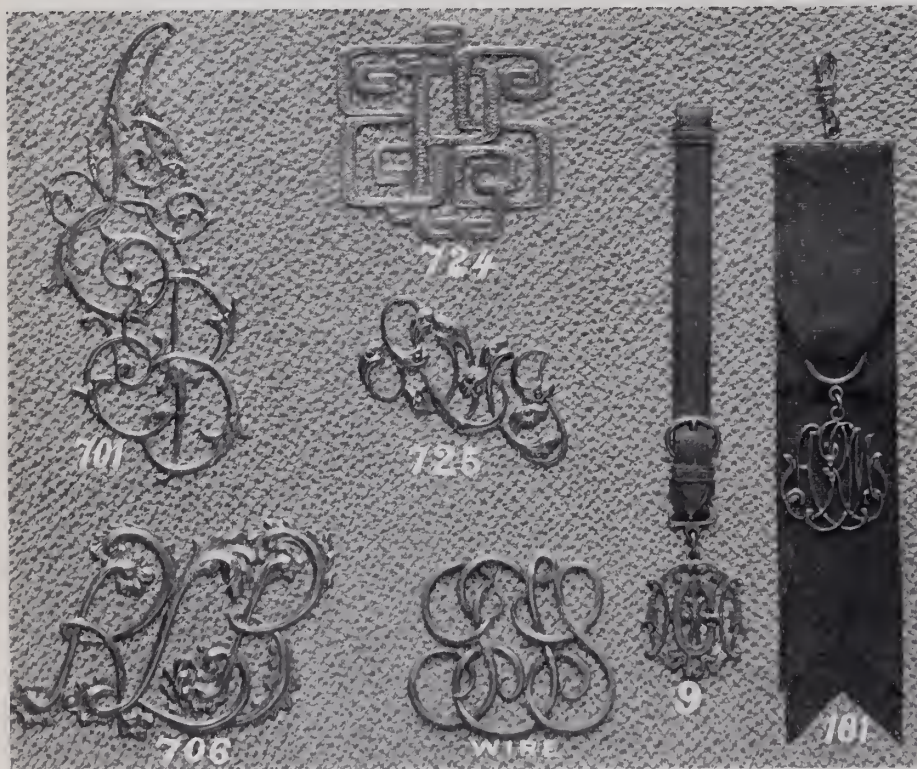

WALDRON & CARROLL

Manufacturers of

— MONOGRAMS —

For Fobs, Pocketbooks, Bags, Belt Buckles, Veil Pins, Brooches, Barrettes, etc. MONOGRAMS inlaid in wood and ivory.

34 WARREN STREET - - NEW YORK

Pittsburg.

George W. Biggs, with the John M. Roberts & Son Co., and one of the best known jewelers in the city, has been ill at his home for a week.

Sam F. Sipe gave out an extensive interview last Friday to all of the afternoon papers, setting forth the diamond situation as it existed up to date.

Albert Heeren, of Heeren Bros. & Co., leaves this week for a trip to Cuba and the Isle of Pines. He has some property interests at the last named place, which he is going to see.

The usual match game was played last Thursday night by the teams comprising the Jewelers' Duckpin League, on the Dispatch alleys. The Roberts team No. 1 defeated the Roberts team No. 2, the Wattles No. 1 the Vilsacks, and the Wattles No. 2 the Terheyden team. Parlett of the Roberts No. 1 team made the only century score of the evening.

The indications are that Goddard, Hill & Co. will move from their present location in Fifth Ave. to quarters in Liberty Ave., although no definite decision has yet been reached. A renewal of the lease at the same rental has been offered the firm, but it desires more commodious quarters. A decision regarding the matter will be made this week.

Among the out-of-town jewelers who were in Pittsburg last week buying goods were the following: Frank Murdock, Ligonier; B. L. Bloser, New Kensington; B. E. Brown, Monessen; H. R. Brown, Donora; E. F. Seaman, Monongahela City; W. D. Wade, Wade Jewelry Co., East Liverpool; John J. Linnenbrink, Rochester; J. F. Murphy, Dawson.

Mrs. Blanca Arons, the mother of B. E. Arons, well known to the trade, died last Friday morning at her home at 926 Heath St., this city. She was 89 years old and one of the oldest and best known Jewish women of the city. She was born in Portugal, and came to this country in 1872. She is survived by nine children, 32 grandchildren and 27 great grandchildren.

The Hardy & Hayes Co. donated a china vase, L. W. Vilsack & Co. a silver syrup pitcher, and John J. Mundorf, the optician, a pair of opera glasses to the prize euchre party given last Friday afternoon at the Alvin Theater by the *Chronicle Telegraph*, in the interest of the relief fund started by that publication, and which has collected about \$15,000 for distribution among the charitable organizations of the city, who are assisting the poor during the present crisis. About 2,000 women attended the euchre, which was a big society event, in the interest of charity.

Acting on advice previously given in THE CIRCULAR—WEEKLY, the Hardy & Hayes Co. this week promptly denied the reports sent out from London that the diamond syndicate was about to be broken up and that there would be a drop in the price of precious stones. J. Alexander Hardy, president of the company, gave out interviews denying the report and the papers gave his statements considerable prominence. These were also substantiated by a statement from J. W. Mayer, of Powers & Mayer, New York diamond importers, who

ppened to be in Pittsburg when the Lon- on story was published. George W. White, of West, White & rristy, last week finally won his suit for sixth interest in the Sutmeyer estate, orth fully \$200,000. He has already re- ived a portion of it. Mr. White married daughter of Sutmeyer, and the latter died fore Mrs. Sutmeyer, leaving his estate his wife, to be distributed at her death. r. White's wife died before Mrs. Sut- eyer, and he secures her share. The ife of Otto Heineman, the North Side weler, is one of the heirs of the estate, nd will also receive a sixth interest. The state has been in litigation for the last ar or more and was only finally decided st week in the Orphans' Court. Mr. White's interest will be between \$30,000 nd \$40,000.

Stanley J. Peters, who conducted a jew- lry shop in Allentown, last week was ommitted into the custody of Sheriff Far- y, of Mercer county, W. Va., and his eputy, M. W. Christy, to be taken to panishburg for trial on a charge of grand rceeny. The officers came to Allentown hursday and arrested Peters as a fugitive rom justice. They had requisition papers rom the Governor of West Virginia. It s claimed that Peters was in business at Bramwell, W. Va., and after some business everse, skipped out 18 months ago with nearly \$1,000 worth of jewelry and other ssets. He was recently located and is arrest followed. Peters at once applied or a writ of habeas corpus, claiming that e was no fugitive from justice. Judge rexler heard the case and refused the rit

The proposal to locate the new city hall on the Market house site appears sure to be adopted. If present plans are carried out the jewelry stores on Market St. be- tween Fifth Ave. and the market, will be forced to move. The building which J. R. Reed & Co. occupies can hardly be bought yet awhile, because the property is in liti- gation, owing to disputes among the heirs of the property, and the courts must de- cide the matter. The lease on this building, however, extends only a year longer. The John M. Roberts & Son Co. have a nine- year lease yet, so that it will be difficult to force the concern to move, unless the city buys the firm's lease. The question is, however, one of most absorbing interest to the jewelers of the city, as these houses and others which will be affected, are among the oldest and best known in the city.

The Philadelphia Optical Club was or- ganized Thursday evening. There is a proposition to file an application for the privilege of the Jewelers' Club rooms, but some of the opticians are in favor of having separate quarters. The following are the officers of the new club: President, John W. Cleary, of Lander, Cleary & Co.; vice-pres- ident, Walter S. Magee, of McIntire, Ma- gee & Brown Co.; secretary, John Martseh; treasurer, William F. Reimold. The direc- tors are: William F. Reimold, Charles H. Sullivan, Jr., John H. Bates, Jr., A. Reed McIntire and William W. Russell. The club has excited considerable interest in the al optical trade and is sure to be a suc- cess.

“ASK YOUR JOBBER”

The Heavy Shanks

COUPLED WITH SUPERIOR WORKMAN- SHIP AND UP-TO-DATE IDEAS ARE WHAT INDIVIDUALIZE THE

UR RINGS

The Untermeyer-Robbins Co.

Seventy-One Nassau Street, New York



580.

FLOWER EFFECTS

OUR

Chrysanthemum Brooches

are sellers. The secret is price—\$18.50 up. Well made, too.

CROSSMAN COMPANY, 3 Maiden Lane, N. Y.

ARTHUR REICHMAN
DEALER IN
AMERICAN BAROQUE PEARLS
65 Nassau St. New York

The Latest Novelty in Cloisonne Enamel

STERLING SILVER WITH BEAUTIFUL TRANSPARENT COLORING

Birth Day Handy Pins



¶ We wish to call particular attention to this line and the rich effect produced with polished silver in combination with the enamel. This is the best hit of the season.

Price, \$7.50 per doz. mounted on an easel pad.

SHEPARD MFG. CO., MELROSE HIGHLANDS, MASS.

Philadelphia

Ferd. Levy, 900 Chestnut St., expects to make an extended stay at Atlantic City with his wife.

Robert Blittersdorf, with C. R. Dankworth, 725 Sansom St., is reported to be critically ill.

William C. Robertson, diamond dealer, 725 Sansom St., spent the week's end at Atlantic City.

Gustavus Beiler, diamond dealer, 125 S. 7th St., has given up his business to enter the insurance business.

Ed. Sickles, of M. Sickles & Sons, made a business trip to the factory of the firm at Newark, N. J., last week.

Carl A. Doubet, a prominent retailer of Washington, D. C., is a visitor to this city combining business and pleasure.

Albert McKinney, watchmaker, formerly at 29th St. and Ridge Ave., has accepted a position with Harry Bipman, 5205 Haverford Ave.

Francis B. Wallen, retailer, 405 Broadway, Camden, N. J., who has been suffering from a painful abscess, has fully recovered.

Additional stock of the Keystone Watch Case Co. to the amount of \$551,400, par value \$100, has been listed on the local stock exchange.

I. Wechsteln, watchmaker for the trade, 725 Sansom St., has given up the business and accepted a position with Harry Weir, Manayunk.

Louis P. White, wholesaler, 9th and Chestnut Sts., is expected back this week from an extended pleasure trip through the south and into the Antilles.

The Bailey, Banks & Biddle Co. made a special display last week of trophies and prizes designed for the Sportsman's Show held in an armory here.

William J. Haines, 2746 N. 5th St., has received the contract to furnish 22 gold and silver medals for award to winners of a series of out-of-door games.

Robert Leusch, retailer, at Front St. above Susquehanna Ave., was one of the jurors who last week convicted Walter Hallowel of murder in the first degree.

Abraham Sickles, of M. Sickles & Sons is one of the incorporators of the Mortgage Building & Loan Association, which has applied for a charter under the State law.

J. B. Bechtel, of J. B. Bechtel & Co., returned Monday from a week's tour of the North Penn territory. Mr. Bechtel says business is improving throughout the State.

George Hurlburt, of H. O. Hurlburt & Sons, started Monday for an extended western trip. William Dawson is ill with grippe. E. C. Jump returned last week after a short illness.

E. J. Hertz, 13th and Chestnut Sts., was one of those who last week tendered a complimentary dinner to Director of Public Works Stearns upon his return from a European trip.

Thomas Bell, engraver, has resigned his position as manager of the engraving department of the Keystone Watch Case Co. to accept a position as head clerk at the Bellevue-Stratford Hotel.

A. F. J. Dorn, 834 Market St., Camden, N. J., displayed in his show window last week a South Bend 17 jeweled watch.

VARISCITE SOHN & HYMAN

Sole Agents

47-49 MAIDEN LANE
NEW YORK

The Newest Stone for High Class Jewelry

LOUIS FELDENHEIMER

Importer and Cutter of

PRECIOUS STONES AND PEARLS

41 MAIDEN LANE

NEW YORK

Gems and Precious Stones

Cloth, Postpaid, \$1.00 Published by
The Jewelers' Circular Publishing Co.,
11 John Street, New York.

rozen in a cake of ice, but still running and keeping accurate time.

William A. Kinna, manager of the Elgin National Watch Co.'s New York office, and James R. Gleason, of the New York office of Robbins & Appleton, were both visitors to this city's trade last week.

While buying jewelry at the wholesale establishment of S. M. Stern & Co., at 432 Market St., Friday, Edward T. Delaney, dealer in men's furnishings at 1221 Girard St., dropped dead of heart disease.

The Philadelphia *North American* recently published a long article on the local jewelers' Club, giving illustrations showing interior views of the club house and portraits of the former presidents and present officers.

Many local jewelers who for years had known John Keane, who traveled this territory for Ostby & Barton, New York, expressed deep regret last week when news of his death reached them through the columns of THE CIRCULAR-WEEKLY.

William Harmon, a young clerk formerly employed by I. Abrahams & Co., retailer, 28 7th St., who stole an envelope from his employer containing checks for \$209 and \$16 cash, Feb. 18, was arrested last week and held in bail for court. The checks were covered, but the money had been spent.

Among the out-of-town retailers buying from local wholesalers last week on their trips to the city were the following: J. M. Lewis, Lambertville, N. J.; H. S. Landis, Frederick, Md.; H. B. MacFarland, Downingtown, Pa.; D. H. Krouse, North Wales, Pa.; R. W. Quicksall, Mt. Holly, N. J.; John MacPherson, Mauch Chunk, Pa.; Clifford Cassel, Norristown, Pa.; J. W. Clark, Bristol, Pa.; William Huber, Elmer, N. J.; Mr. Thomas, Phoenixville, Pa.; E. H. H. Millz, Millville, N. J.

The Puritan Mfg. Co., an Iowa corporation, won its suit in Judge Kinsey's court last week to recover on two promissory notes for \$225.14 against Christopher Koch, a local druggist. Koch had declared that the jewelry which he had purchased from the company was not as represented, and refused to meet the notes. He declares that he will appeal the case, and, further, that he will be aided by others who, he says, have not been satisfied with the goods bought of the Puritan company. The company places gold-plated jewelry in drug stores throughout the country.

Alfred A. Phillips, manager for J. J. Round & Co., instalment jewelers, 9th St. below Market St., was arrested twice last week on two separate charges of larceny and has been held in bail for trial. Catharine Hayes, 634 Jackson St., it was alleged, had been made a present of a ring which W. S. Quigley, 2224 S. 63d St., had bought from Philips on the instalment plan. Quigley lapsed in payments and Philips is said to have gone to Miss Hayes' place of employment, and, charging her with stealing the ring, forced her to surrender it. John O'Kane, another complainant, says he purchased a \$22 watch from the Round concern and paid \$8 in instalments for it. When he lapsed Phillips is said to have represented himself as a detective and to have arrested Kane. He took him to his own house, and after threatening him made him surrender the watch.

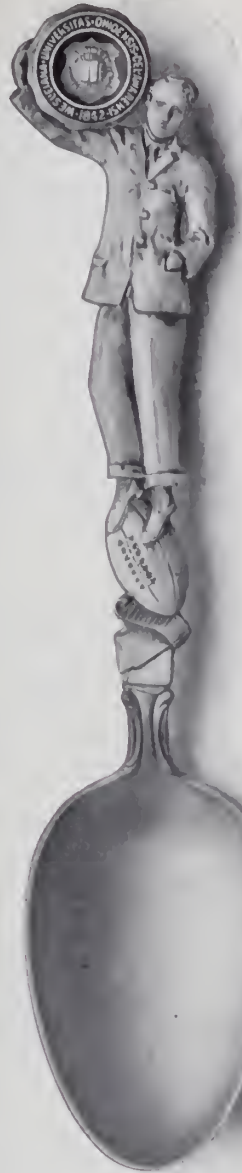

WE have called the trade's attention to "The Spoon Family" and have sent many samples. Why not get in line and carry goods which are great sellers?

"The Whole Family"

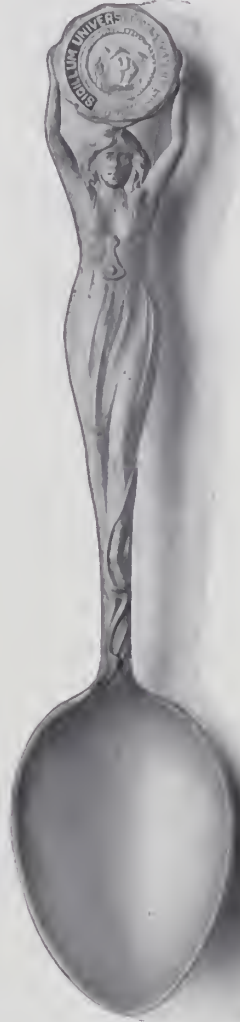

Now is the time, Mr. Retailer, you need sales. Carry goods made by us, and you have the assurance of large sales of College Jewelry.

OUR customers never have shop-worn goods to be refinished.

THE KINNEY CO. Main Office and Factory, 14 Blount St. PROVIDENCE, R. I.

Gems and Precious Stones

Their Characteristics, Localities of Production, Tests and Some Current Literature

CLOTH, POSTPAID, \$1.00

Published by THE JEWELERS' CIRCULAR PUB. CO., 11 John St., N. Y.

ANNOUNCEMENT

On May 1st,

THE GORHAM COMPANY

will remove its Maiden Lane store to the New Silversmiths Building, Nos. 15, 17, 19 Maiden Lane, occupying the ground floor and basement.

THE STORE NOW OCCUPIED BY US
AT NOS. 21 AND 23 MAIDEN LANE,

FOR RENT

Apply to

GROSS ^{AND} GROSS COMPANY
MANAGERS

COURTLAND E. HASTINGS, Agent
171 Broadway, Room 5

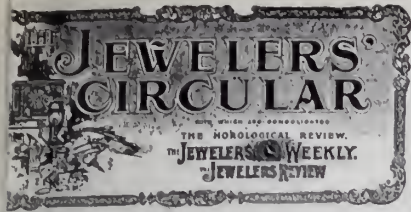

PUBLISHED EVERY WEDNESDAY BY
THE JEWELERS' CIRCULAR PUB'G CO.
 J. Mulford, Pres. & Treas. V. S. Mulford, V. P. & Sec.
 11 JOHN ST., COR BROADWAY, NEW YORK.
 TELEPHONE: 49 CORTLANDT. CABLE ADDRESS: JEWELAR, NEW YORK.

OL. LVI. MARCH 18, 1908. No. 7.

Subscription in United States and Mexico, \$2.00
 million of Canada, 3.00
 other Countries in Postal Union, 6.00
 Single Copies,10
 Sent by check or money order. Remittances in money are at sender's risk.

Index to News and Special Articles.

	Page.
Reproductions of Antique Irish Brooches. Illustrated on	Front cover
Commerce of the Philippine Islands in Watches, Clocks, Jewelry, etc.	37
Annual Monthly Import and Export Statistics	37
Latest Bee's Fashions	38
Some Notable Reproductions of Ancient Irish Jewelry and Silverware	39-41
Widow's Work and Chasing—(Continued)	43
Corporation Reports Filed by Jewelry Manufacturing Concerns of Massachusetts	45
Three Thieves Boldly Smash Window of York, Pa., Jewelry Store and Secure Rings Worth \$600	45
Jewelry and Kindred Lines Exported From New York	45
Death of Walter E. Hayward's Business Due to His Breakdown in Health	45
Newark Manufacturers Listen to Lecture on Technical Education	47
Wisconsin Jewelers at Formal Meeting Decide to Donate Clocks to the City	47
Armed Thief Escapes With \$700 Worth of Stock From Store of Jewelers in New Haven, Conn.	49
Erman Kern, Bankrupt Jeweler, Knoxville, Tenn., Sent to Prison for Two Years	49
James Rolled by Jewelers' Bowling League	49
Walter M. Tucker, Greenville, S. C., Goes Into Voluntary Bankruptcy	49
Members Paid and Members Elected by the Jewelers Security Alliance	49
V. P. McFarland, Orange, Tex., a Voluntary Bankrupt	49
Bankruptcy Petition Filed Against Maurice C. Dreshfield by Creditors Who Claim He Got Diamonds Worth \$182,000 on False Representations	51
Short Change Swindler Who Has Been Operating in Brooklyn Gets Diamonds From a Pawnbroker	51
Diamond Market in No Danger—Cables From Abroad Show Newspaper Stories to Be Absurd	51a
Goldman & Co. Offer 25 Per Cent. Settlement	51b
Bids Solicited by Government Departments	53
Imports at New York	53
New Enterprises	54
Gold Bars Withdrawn and Exchanged	54
Patent Department	85-87
A Catechism of the Lever Escapement—(Continued)	89-91
The Clock in the Church at Lund (Sweden)	91
Karrusel Watch Constructed by a Watchmaker of Los Angeles, Cal.	93
Proposals Invited for Electric Clocks for New Municipal Building in Washington, D. C.	93
Ingenious Methods Invented in Order to Protect Jewelry Stores Against Burglars	102-103
The Making of Good Jewelry Advertising Copy	104-105
Workshop Notes and Queries	107
A Method of Saving Gold From Rinse Water	107
Reproductions of Ancient Pottery of Crete in the Metropolitan Museum of Art	109
Old Glass and Pottery Sold in London	111
High Prices for Old Silver Sold at London	111
A Notable Addition to the Bronzes of the Metropolitan Museum of Art	111

A Past Performance Recalled. **T**HE CIRCULAR-WEEKLY has always made it a special point to protect its subscribers against swindlers by giving the greatest possible publicity to all attempts to rob the trade, with descriptions of the swindlers, and wherever possible pictures of those who seek to make jewelers their victims. This policy has not only resulted in the arrest of many clever crooks, but has also been the means of saving our subscribers from losses which can be truthfully estimated in the hundreds of thousands of dollars. An important instance of this kind was recalled last week when the postoffice inspectors of New York arrested a man whom they claim is "Abe" Rothschild, a noted swindler, and whom they now charge with using the mails to defraud, but whose work in the jewelry trade was stopped by this journal.

The Rothschild referred to, who has a long career of crime, early in 1895 started on a campaign of swindling jewelers, and under the name of J. C. Coleman, succeeded in getting a quantity of merchandise from Georgia merchants, swindling jewelers at Atlanta, Augusta, Macon, Savannah and even Charleston. He skipped out from Georgia in March and started to operate in other sections of the country, but fortunately for the trade his plan of campaign was exposed by this journal in the issue of March 20, 1895, was read by our subscribers, and within five days of its publication Rothschild was captured in Canada as he was about to work a similar swindle on jewelers of Hamilton. Thomas Leese, of that city, who had read THE CIRCULAR's account carefully, recognized Rothschild's tricks the moment he tried to get goods from Geo. H. Leese & Co. and the Levy Bros. Co. under the name of T. Hutton.

Though this is but one of the many swindlers that THE CIRCULAR-WEEKLY has brought to justice, the Rothschild case was probably the one in which the publication of the methods of the swindler resulted in the capture in the quickest possible time, the issue of this journal having gotten to Canada with an account of his operations practically before the swindler could arrive there on his flight from Georgia.

Whether or no Rothschild (if the man arrested be he) is again sent to prison on the present charge is now of little interest to the jewelry trade, because the lesson that he learned in his previous acts has taught this swindler that jewelers read their trade paper and through it are informed of what happens to their brother merchants in other parts of the country, so that it is a dangerous trade to operate in more than once. Many crooks have learned the same lesson in the past and no doubt more will learn it in the future, but in the meantime it behooves the jeweler to read THE CIRCULAR-WEEKLY carefully and become conversant with all the details of the swindling schemes published from time to time. Also for the sake of his fellow-merchants the jeweler should never lose an opportunity to inform us when an attempt to swindle him is made, whether it be successful or unsuccessful, that we may give warning to others upon whom the swindler may

pay a visit in the future. In this way the subscribers of THE CIRCULAR-WEEKLY can act as one large organization for mutual protection.

Newspaper Canards About the Diamond Market. **T**HERE has probably been no time in the history of the business world of this

country where an industry has been the subject of such needless and baseless attacks as the diamond trade has received in the past two weeks or so by the newspaper press in general, and it is safe to say that few lines of business have been in a position to withstand it in the manner that the diamond trade has done. Without any rhyme or reason and without an authentic fact to go upon, newspapers in every part of the country have in the last week published all sorts of stories tending to give the impression that the diamond market was about to collapse, that diamonds would be cheaper, and that the industry was demoralized; and this despite the fact that prices have been thoroughly maintained from the syndicate to the retailers, and that it is the firm belief of every large importer and cutter in the country that if any change in the market price is made in the future at all it will be in an upward direction.

The only excuse for those stories and the only pegs around which they could build them at all was the drop in the price of the shares of the De Beers Consolidated Mines and the Premier Mining Co. upon the stock exchange, and the fact that the syndicate in London, which controls the De Beers output and also that of the Premier mine, was negotiating with the latter for a renewal of the contract which expires on March 29.

The decrease in the output of the diamond mines, as well as the decrease in the demand for diamonds throughout the world, are responsible in part for the drop in the price of diamond mine shares, and undoubtedly this tendency was augmented by a campaign to "bear" the market for these shares, but the value of the shares of the diamond mines has had, never had, and never will have, any direct effect on the market price of diamonds alone, but is dependent upon the amount sold and the profits made. However, this fact is carefully disguised in the newspaper accounts which spoke of the fall of "prices" until they reached the lowest ebb, not mentioning that the prices were the prices of the shares, and not of the diamonds. These stories which are supposed to emanate from London were picked up and featured by the American papers, which, in addition, had a new story based on a rumor published in a London "yellow journal" that the Premier might not renew its contract with the syndicate, and around these "facts"—or, more properly, erroneous inferences—were built the wild stories of the "possible war between the diamond companies," with the "consequent reduction in prices."

As everyone conversant with the trade well knows, even if the contract between the Premier and the syndicate should not be renewed there is little reason to expect any material effect upon the diamond market, as it would simply bring conditions back

ROCK BOTTOM PRICES ON DIAMONDS

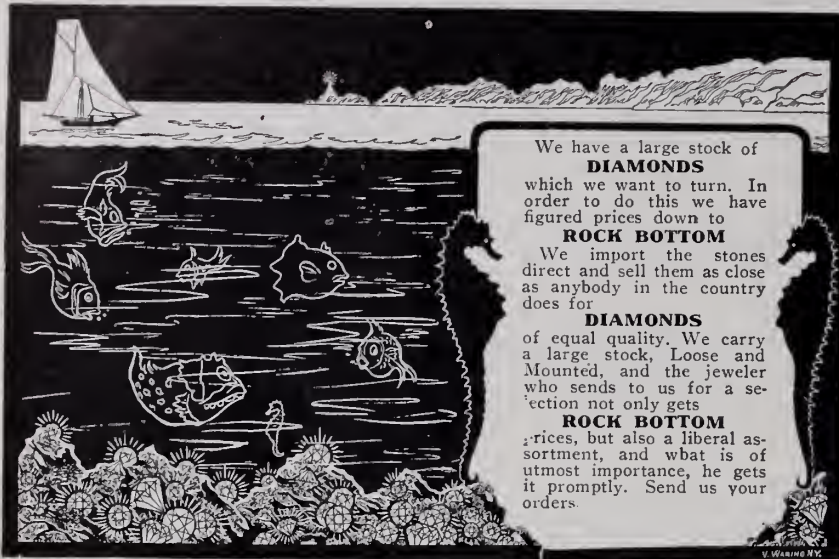

We have a large stock of
DIAMONDS

which we want to turn. In order to do this we have figured prices down to

ROCK BOTTOM

We import the stones direct and sell them as close as anybody in the country does for

DIAMONDS

of equal quality. We carry a large stock, Loose and Mounted, and the jeweler who sends to us for a selection not only gets

ROCK BOTTOM

prices, but also a liberal assortment, and what is of utmost importance, he gets it promptly. Send us your orders.

CROSS & BEGUELIN

Importers and Cutters of Diamonds and Precious Stones

43 Rue de Meslay, PARIS

Telephone,
480 John

31 Maiden Lane, NEW YORK



Trade-Mark

OUR guiding principle has always been to incorporate as much artistic skill and good material in the construction of our jewelry as possible. This is contrary to the skimming, economic operations so extensively practiced in the manufacture of inexpensive gold jewelry. In observing this standard we naturally sacrifice the petty profits resulting from the less exacting methods of others; nevertheless our jewelry is consistently low priced and of a quality away beyond the ordinary.

Ask to see it and look for our trade-mark—the imprint of originality and all that's good.

85 Sprague Street
PROVIDENCE, R.I.

H. A. KIRBY

9-11-13 Maiden Lane
NEW YORK CITY

to where they were before the present contract was made some six months ago, when the nearly 90 per cent. of the diamond product which came from the De Beers mines determined the market price which the Premier people took advantage of. In fact it would be business suicide for the Premier mine to attempt to cut under the market price, and no one with sense for a minute supposes that such a proposition is possible.

How far from the truth all these articles on the diamond market have been was clearly shown in the two cables received from New York, Monday, which are reproduced in another column of this issue. One cable, which was from W. Busch, the London agent of the Premier Diamond Mining Co., Ltd., states that the Premier company has no intention of lowering prices regardless of the question of the continuation of the present agreement with the syndicate while the other cable which is from L. & Abrams, on behalf of the syndicate, states that the syndicate firmly intends to maintain prices as hitherto.

As a matter of fact, however, it is distinctly probable that the contract between the syndicate and the Premier mine will be renewed and nothing has developed that would in any way give a basis for the stories of a break. THE CIRCULAR-WEEKLY conclusively showed this last week in its cables from L. & A. Abrahams and M. Busch, to the effect that the negotiations for the renewal of the contract are pending and all parties are doing their best to come to an arrangement. The contract does not expire until the end of this month, and it is but natural that both parties of the agreement should dicker for the best possible terms of renewal.

The tendency of the newspapers of this country to give prominence to every report that tends to indicate that the diamond market is not stable is as general as it is unexplainable, and the inference that there is concerted action or a campaign to "beat" the diamond market generally, therefore does not seem unreasonable, though we could benefit thereby outside of the manipulating the shares of the diamond companies is hard to understand. However, enough has been published to show the jeweler that practically no reliable whatsoever can be placed on the newspaper reports of the diamond trade, and he will have to make this clear to his customers every way possible.

THE CIRCULAR-WEEKLY is and will be in a position to give the trade complete news of everything that develops in the diamond market, and it will do so at the earliest possible moment. Our news will be uncolored and can be relied upon by the trade absolutely accurate in every respect. The jeweler can feel that through THE CIRCULAR-WEEKLY he will be made conversant with every essential fact that bears upon the situation, and can rest content in paying attention whatsoever to any newspaper reports at all unless he sees them confirmed by the reports of this journal.

Schultz & Lapp have been incorporated in Newark, N. J., with a capital stock of \$25,000, to engage in the jewelry business. The incorporators are F. L. Schultz, J. Lapp and Edw. G. George.

New York Notes.

The Schwarz Co. has been incorporated manufacture jewelry boxes with a capital of \$25,000. The directors are: Charles Schwarz, Frank F. Schwarz and Harry O'Brien.

The Oriental Jewelry Co., this city, has been incorporated with a capital stock of \$100,000. The directors are: Joseph L. Epstein, George T. Van Valkenburgh and James Fletcher Ruark, all of this city.

A clock is being made by the Seth Thomas Clock Co. for the Library building Westport, N. Y. This clock is a gift from the widow of the late Robert C. Black, Black, Starr & Frost. A clock is also in process of construction by the same company for the Sacred Heart Church, Brook-

The long-established house of C. A. Fursch, 198 Bay St., Stapleton, Staten Island, has changed its firm name to C. A. Turpisch Sons. The founder of this firm learned his trade in the workshops of Paris and London, and his sons, Walter and Rolland, have been educated in the business. Walter, the oldest son, is an optician, and Rolland a goldsmith.

Creditors of L. Witsenhausen are notified that a hearing will be held in the United States District Court, March 23, relative to the bankrupt's petition for the acceptance of a composition offer which was made some time ago. Mr. Witsenhausen offered a composition in bankruptcy, and is now asking that the composition be confirmed by the court.

At the regular monthly meeting of the board of directors of the Jewelers' Board of Trade held last Thursday at the Board's rooms, 170 Broadway, the following firms were unanimously elected to membership in the board: The Brown & Dean Co., Providence, R. I.; Peninsular Engraving Co., Detroit, Mich.; Simnoek & Sherrill, New York, and American Exchange National Bank, New York. (Associate.)

Albert C. Ward, alias Col. Ward, a man 44 years of age, whose portrait was published in a recent issue of THE CIRCULAR-WEEKLY, was arrested Wednesday at Vanamaker's, in this city, by Detective Lieutenants Murphy and Pollack, and committed to await extradition papers from Massachusetts. He is wanted in Boston. The police in this city have been looking for him for some time past. He had been trying to pass bogus checks.

A man who gave the name of John Edwards was arrested Friday evening on a charge of burglary on complaint of Victor L. Hote, 238 W. 53d St. The jeweler, according to the detectives, left his store a short time and went to his apartments on the third floor. Upon his return a few minutes later he found two men ransacking his stock. The intruders fled, and the jeweler gave chase. At 55th St. Edwards was captured. The prisoner had four gold watches, which the jeweler said he recognized as his property.

Hiram A. Stevens, who was at one time a wholesale jeweler in this city, but retired from business in 1897, died Tuesday of last week at his home, 14 Palmetto St., Brooklyn, at the age of 76 years. He was originally from Connecticut, and came to Brook-

lyn in 1875. He was a member of Calvary Protestant Episcopal Church and an active member of the Men's Club at that church. He is survived by a widow, a daughter and a son. The funeral services were held Thursday evening from his late home, Dr. Williams officiating. Interment was private.

James Myers, a Poughkeepsie jeweler, learned last week that he had been left \$20,000, the residue of the estate of Charles Grube, who was for many years a professor of music in Vassar College, and who died at the age of 94 years a few weeks ago. For the last 30 years Mr. Myers had often visited him. It was Mr. Myers who found the aged man dead in bed. It may be of interest to know that Mr. Myers was at one time in business with D. A. Ainley under the firm style of Myers & Ainley, in Poughkeepsie. Mr. Ainley is now with the Aikin-Lambert Jewelry Co.

The hearing in the customs controversy which has arisen between the Government and importers over the importation of so-called "miners'" diamonds, which was adjourned until last Friday in order to enable the Treasury Department counsel to produce witnesses to substantiate the 10 per cent. duty, has again been adjourned until Friday of this week. A test case has been brought by the Sullivan Machine Co., of Chicago. The contention of the Government is that since the stones have been split the value has been advanced and that a duty of 10 per cent. should be imposed. The "miners'" diamonds have previously been admitted duty free.

A meeting of creditors of Adolph Hodes, 65 Nassau St., was held at the offices of Referee in Bankruptcy Allen, 67 Wall St., Thursday of last week. The first meeting was called at 10.30 A. M. to consider an offer of \$7,500 for the stock of the bankrupt. At this time the trustee was authorized to accept the offer for the stock in the event that a composition in bankruptcy offered by the bankrupt is not confirmed. A second meeting at 11 A. M. considered the offer of the bankrupt of a 50 cent settlement as follows: Ten cents in cash, 10 cents in four months and five cents in eight months, on notes of the bankrupt endorsed by Jeannette Hodes. The last three payments, namely, five cents in eight months, 10 cents in 12 months and 10 cents in 16 months, are to be endorsed by Minnie Brothers or secured by a person agreeable to the committee of creditors. This offer has been accepted by a majority of the creditors.

Judge Lacombe, of the United States Circuit Court, Friday of last week, issued an order permitting Charles A. Hanna as receiver of the new Amsterdam National Bank to adopt the liquidating plan whereby the claims against Joseph Frankel's Sons, Joseph Frankel's Sons Co., E. M. Gattle & Co. and Gattle, Ettinger & Hammel, held by the bank, may be transferred to the liquidating trustees, James G. Cannon, Louis Kahn and John C. Van Cleef, liquidating trustees. Receiver Hanna sets forth in his petition that among the claims held by the bank at the time of his appointment as receiver was one for \$45,000, on the promissory note of Joseph Frankel's Sons Co., endorsed by B. J. Frankel and S. Frankel, for which the bank held as collateral 1,000

shares of E. M. Gattle & Co. and two pearl necklaces. The necklaces were appraised at \$11,000. Another claim was for \$70,000, on a note of E. M. Gattle & Co., bearing the personal indorsement of E. M. Gattle. The liabilities of these firms, Mr. Hanna is informed, aggregate \$1,547,890, while the assets if properly husbanded will be over \$6,000,000. The Bankers' Trust Co. has been named as depository and all the creditors have assented to the plan.

"Abe Rothschild," who was arrested last Friday in Manhattan by detectives and post-office inspectors, charged with conducting a swindling scheme under the name of "The Successful Business Man," a fictitious journal, is believed to be the swindler of that name who served a term for cheating jewelers. Arnold G. Cahn, Rothschild's partner, was also arrested. The two men were arraigned before Commissioner Shields Saturday morning and held in \$5,000 and \$1,000 bail respectively for examination. Abe Rothschild will be recalled by CIRCULAR-WEEKLY readers as one of the boldest jewelry swindlers that menaced the trade in former years. Some years ago he operated in the South Atlantic States. At that time THE CIRCULAR-WEEKLY was directly instrumental in the arrest of the famous crook in Toronto, Can., in 1895. Rothschild was born in St. Louis and came of a good family. He early married a woman known as "Diamond" Bessie Moore. She was famous for the diamond jewelry she wore. His wife was murdered and all her jewelry stolen shortly after the marriage and Rothschild disappeared, but was found shortly in Cincinnati, where he attempted suicide by shooting. He was later convicted of murder and sentenced to death, but a new trial was granted and he was freed. From that time he has been mixed up in a number of swindling games.

An important event in the jobbing trade is the announcement that M. A. Mead & Co., Chicago, who also have an office in Pittsburg, have decided to open a New York branch as well and enter the field in the east. Mr. Mead, accompanied by J. T. Montgomery, vice-president of the concern and manager of the Pittsburg office, were in New York last week perfecting arrangements for the establishment of the branch in this city. Mr. Mead closed negotiations for an office in one of the larger buildings on Maiden Lane, the exact location of which is not made public at present. The office will be open some time in June or July. In speaking of the matter to a representative of THE CIRCULAR-WEEKLY, Mr. Montgomery stated that the opening of a New York office was in line with the policy and progress of the house, which would enter the field for eastern business, practically as an eastern house. This would in no way mean that the Pittsburg office would be superseded, as the office in that city will be continued by W. C. Owen, who has been with the concern 20 years, and who will continue to take care of the Pittsburg territory. Some of the travelers now traveling from the Pittsburg office and covering the south and Atlantic sections, will be transferred to New York and other travelers added to cover the remainder of the Atlantic States. Mr. Montgomery will have

ESTABLISHED 1852

THE NASSAU BANK

Original Clearing House Member

Corner Nassau and Beekman Streets - - - - NEW YORK

Title Guarantee and Trust Co.

176 Broadway (between John St. and Maiden Lane), New York

Capital and Surplus - - - - \$12,000,000

Deposits received subject to Check. Interest allowed. Letters of Credit issued. Drafts drawn on Great Britain and the Continent. All Banking Facilities afforded to Customers. Accounts of Jewelers are especially solicited.

Finance Committee in Charge of Banking Interests

E. T. BEDFORD, 26 Broadway
 C. H. KELSEY, President
 E. L. MARSTON, of Blair & Co., Bankers
 W. H. NICHOLS, General Chemical Co.

CHARLES A. PEABODY, President Mutual Life Ins. Co.
 JACOB H. SCHIFF, of Kuhn, Loeb & Co.
 JAMES SPEYER, of Speyer & Co.
 E. O. STANLEY, 2d Vice-President

BRANCH BANKING OFFICES: 196 Montague St. and 175 Remsen St., Brooklyn; 350 Fulton St., Jamaica; 67 Jackson Ave., Long Island City

The Market and Fulton National Bank of New York

ORGANIZED 1852

81-83 FULTON STREET

Capital, \$1,000,000

Surplus, \$1,500,000

PROGRESSIVE—CONSERVATIVE—SUCCESSFUL

ALEXANDER GILBERT, President
 R. A. PARKER, . . . Vice-President
 T. J. STEVENS, Cashier
 JOHN H. CARR, . . . Asst. Cashier

Invites the Accounts of Jewelers

Will extend every facility that good banking will justify

SAFE DEPOSIT VAULTS

THE STATE BANK

376-378 GRAND STREET, NEW YORK

Capital and Earned Surplus, over \$1,500,000. Deposits over Fifteen Millions.

Offers a favorable market for short and long time jewelry and diamond paper.

The Mercantile National Bank

OF NEW YORK

WILLIS G. NASH, President

MILES M. O'BRIEN, Vice-President

WM. SKINNER, Vice-President

WILLIAM H. TAYLOR, Vice-President

EMIL KLEIN, Cashier

DIRECTORS

WILLIAM F. CARLTON,
ROBERT C. CLOWRY,
WILLIAM NELSON CROMWELL,
L. H. CUTTER,
EDWIN GOULD,
HAROLD A. HATCH,

EDWARD T. JEFFERY,
WILLIAM H. LAWS,
WILLIS G. NASH.
BENJAMIN NICOLL,
MILES M. O'BRIEN,
CHARLES E. PERKINS,

DICK S. RAMSAY,
WILLIAM SKINNER,
E. D. STREET,
WILLIAM H. TAYLOR,
E. J. TRUSSELL,
WARNER VAN NORDEN,

Strictly a Commercial Bank
Accounts Solicited

1851

The Jeweler's Bank for half a century
in the same location.

1908

THE
CHATHAM NATIONAL
BANK

Broadway and John Street, New York

 ACCOUNTS INVITED

GEORGE M. HARD, President

WILLIAM H. STRAWN, Cashier

HENRY L. CADMUS, Assistant Cashier

SEND YOUR SWEEPS to the
Cincinnati Gold & Silver Refining Co.

REFINERS, ASSAYERS AND SMELTERS

Office, 523 Elm Street; Works, 2257 Eastern Avenue; CINCINNATI, OHIO

Highest Price Paid for Gold, Silver and Platinum Platinum and Gold Filings Refined by the Russian Method

PRACTICAL COURSE IN ADJUSTING

Published Price, \$2.50.

Special Reduced Price, \$1.50, Postpaid.

The Jewelers' Circular Pub. Co., 11 John St., N. Y.

An Opportunity to Buy
\$140,000 Worth of High Grade
Diamond Jewelry at Low Figures

Being obliged to vacate our store at short notice,
owing to the building being torn down, we have
decided to discontinue our retail business and sell
the same at auction (W. H. Brokaw, auctioneer),
beginning March 25th.

INSPECTION INVITED

 H. A. GROEN & BRO.

OFFICE AND FACTORY:
51 MAIDEN LANE

1503 Broadway, New York

New York Notes.

(Continued from page 67.)

charge of the New York office and will take his headquarters therein.

Ernest Wolff, formerly at 328 W. 125th St., has moved to 386 W. 125th.

Samuel L. Hammond & Co., 71 Wall St., will move to 72 Wall St. about May 1.

Isaac Golden, jeweler and optician, moved recently from 238 Bleecker St. to 328 W. 25th St.

"Ludwigs" Fifth Ave. store will be removed to the Broadway store between 20th and 21st St., about April 1.

G. O. Moore, of the San Francisco branch of the L. E. Waterman Co., was at headquarters in this city last week.

The business of Snow & Westcott, 21 Maiden Lane, has been incorporated as the Snow & Westcott Co., with a paid-in capital of \$50,000. There is no change in the personnel of the concern.

The Britannia Art Glass Co. has been incorporated to manufacture art glass ware with a capital of \$10,000. The incorporators are Morris D. Greengard, A. Magin, and Jacob Ehrlich, all of this city.

The memorial window in St. Luke's Church, Marietta, O., which was illustrated in the last issue of THE CIRCULAR-WEEKLY, was one presented by M. J. Averbeck, 10 Maiden Lane, in memory of his mother.

Henry Greenthal, representing Albert Lorsch & Co., has just returned from a trip through the south. He reports that the erroneous statements in the newspapers have had a detrimental effect on the condition of trade in the south.

John Kohler, a native of this city, for many years in the employ of Tiffany & Co., was found dead in bed Saturday morning at his home in Belleville, N. J. Death was due to heart disease. He was 50 years old. His widow and three children survive.

News was received in this city Monday of the incorporation of the firm of J. Hoare & Co., Corning, N. Y., to manufacture glass and glass ware, with a capital of \$100,000. The incorporators are James Hoare, Geo. L. Abbott and Hasell Baldwin, all of Corning.

Louis La Gatta, a jeweler living at 68 E. Grand Ave., Corona, Queens, received through the mail recently a Black Hand letter demanding the payment of \$1,000, to be placed in a certain spot near his home. The letter has been turned over to the police.

Alfred Schickerling, manager of the Elk Jewelry Mfg. Co., has returned from Europe, whither he went early in February to visit his mother. While in Europe he secured many ideas for designs in animal jewelry. He will be at his office, 51 Maiden Lane, after to-day.

V. S. Mulford, of the Jewelers' Circular Publishing Co., returned Monday from a three weeks' trip spent in Augusta, Ga., where he was stopping with his family at the Bon Air, and while in that city was the recipient of a number of courtesies from Wm. Schweigert, of Wm. Schweigert & Co.

The Keller Mfg. Co., 29 Gold St., has been incorporated under the laws of New York State to manufacture jewelry, with a capital of \$25,000. The incorporators are Adam Keller and Frank J. Keller, New

York, and Adam E. Keller, Westfield, N. J. The firm is composed of a father and two sons.

Charles A. Webber, the diamond broker formerly in business at 320 Fifth Ave., who was convicted of grand larceny Tuesday of last week in Part III. of the Court of General Sessions, after a trial which began the previous Thursday, as was reported in the last issue of THE CIRCULAR-WEEKLY, was sentenced to prison Friday by Judge Crain to not less than one year and six months and not more than two years and six months. He was charged with the larceny from Ledcke & Heiser, 170 Broadway, of a pearl necklace valued at \$6,500.

G. B. Umsted, a dealer in American pearls was among the passengers who landed in this city Sunday from the American liner *New York*. He went abroad in January to dispose of a quantity of American pearls. He brought \$8,000 worth back with him and, despite the fact that he had a consular certificate to show that the pearls had been taken out of the country and therefore were entitled to enter free, they were taken from him. The goods were not declared. Mr. Umsted said that he had no intention of smuggling, but the pearls were ordered sent to the public stores.

Deputy Sheriff Burnes has been busy for several days reclaiming many diamonds from pawnbrokers, which are claimed as the property of Freudenheim Bros. & Levy, 54 Maiden Lane, and were taken, it is alleged, by Harry Levinsohn, who was a traveling salesman in their employ and who pleaded guilty to a charge of larceny in the court of general sessions two weeks ago. The goods were pawned by a third party. The replevins are against Barney Gutter, \$4,037; Barney and Charles Gutter, \$5,235; William Goldstone, \$1,100; Joseph & Henry Sobel, \$825, and Charles Sobel, \$429.

Announcement was made Friday that the firm of Black, Starr & Frost, silversmiths, has been dissolved and that a corporation has been formed under the same corporate name. The deaths of Aaron V. Frost and Robert C. Black brought about the dissolution. The business will be continued at Fifth Ave. and 39th St. Edward H. Peaslee is president of the corporation; R. Clifford Black, vice-president; Witherbee Black, secretary and treasurer, and William L. Rich, general manager, who, together with Mary G. W. Black, Leontine I. Frost and Theodore Silkman, are the directors.

A meeting of the creditors of Horowitz Bros., 196 Canal St., against whom a petition in involuntary bankruptcy was filed in January, was held last Friday before Referee Cox, at which time Isadore Horowitz, of the firm, was examined. Mr. Horowitz testified relative to the history of the firm, and said that he considered the condition of the firm's business better July 1, 1907, than it was in January of that year. He was shown a statement dated July 20, 1907, and questioned about the assets and liabilities of the firm. He testified that in looking through the stock there were lots of old goods which could not be disposed of to-day, and that the stock, in his estimation, had become depleted to the amount of \$15,000.

Abraham Rainess has brought an action for libel, claiming \$20,000 damages against

Charles P. Goldsmith and Isaac Loch, of C. P. Goldsmith & Co., in the New York Supreme Court, and the complaint was filed last week. Some time ago the plaintiff began the manufacture of a scarf pin or brooch protector known as the "lion's grip," and he claims that C. P. Goldsmith & Co., who controlled a patent on a device of this kind, sent out a notice to the trade stating that the "lion's grip" was an infringement of the device in question patented by Max H. Fischer, whose agent they were, and warning the trade that it was their intention to bring action against what they considered to be an infringement. Rainess claims in his suit that the "lion's grip" is not an infringement of the Fischer patent and that the circulars of C. P. Goldsmith & Co. caused him to lose sales for the same from a number of firms whose names he gives. He, therefore, demands damages. No answer to the complaint has as yet been filed.

At a meeting of creditors of Harry Goldberg, Cleveland, O., held Monday afternoon at the Board of Trade rooms, an offer of settlement at 45 cents on the dollar was discussed. This offer was agreeable to the creditors and an attempt will be made to put through a settlement on that basis. The settlement calls for 5 per cent. in note due April 15, 1908; 10 per cent. due July 15, 1908; 5 per cent. due Oct. 15, 1908; 5 per cent. due Jan. 15, 1909; 5 per cent. due April 15, 1909; 10 per cent. due July 15, 1909, and 5 per cent. due Jan. 15, 1910. The notes are to be executed and delivered within 10 days of the date of acceptance of this proposition by 90 per cent. of the creditors, all the notes to be indorsed by David Goldberg, of New York. The assets are placed at \$16,624.92 in stock and \$7,750 in fixtures, with liabilities of \$31,990.05, of which he owes his brother, David Goldberg, \$11,000.

A meeting of creditors of Louis Halpert, 51 Maiden Lane, against whom an involuntary petition in bankruptcy was filed in January, was held at the offices of Referee Nathaniel E. Smith, 68 William St., last Friday, at which time Mr. Halpert was examined. He testified that the schedules filed Feb. 17, 1908, signed Lewis Halpert, were his, and that he gave a statement in November, 1907, to Attorney Gross of his assets and liabilities. He said he read the schedules before he signed them, and that he assisted in the preparation of them. He said that the schedules set forth his standing the same as the original memorandum prepared with Mr. Gross. He testified that he made a statement to a mercantile agency and to the Mercantile National Bank. Asked about life insurance policies, he said he carried a policy with the Equitable Life Assurance Society for \$1,000, and that he left his policy with the company for a loan of \$175. He also had \$2,000 in the New England Life Insurance Society. Schedules B-3, subdivision C, were shown him, in which the word "none" appeared after "policies of insurance." Mr. Halpert said the statement as he gave it was the correct one. He said he did not carry insurance in 1907 on his stock, and that he had not drawn out money from the business for speculation. The meeting was adjourned until to-day at 3.30 p. m. at the same place. At a meeting held March 10 Saul E. Rogers was elected trustee under a bond of \$1,500.



GNTERPRISING and successful jewelers everywhere are pushing the sale of some individual line of watches which they believe to be superior to all others, and upon which they can also make a satisfactory and justifiable profit.

This explains the growing demand for **ILLINOIS WATCHES**, in 0, 12, 16 and 18 sizes, by increasing numbers of leading jewelers throughout the United States.

If you are not familiar with the superior quality of—and advantages gained by handling—**Illinois Watches**, it will mean reputation and dollars for you to investigate.

Every one fully guaranteed.

Price List sent on application.

ILLINOIS WATCH COMPANY

SPRINGFIELD



Western Office:
501 HEYWORTH BLDG., 42 E. Madison St.,
CHICAGO.

Telephone:
5125 CENTRAL,
CHICAGO.

COL. LVI.

CHICAGO, WEDNESDAY, MARCH 18, 1908.

No. 7.

Chicago Notes.

A Dayton is on a trip through Illinois.
C. D. Peacock and wife are on a trip to Mexico.
Elisha Thayer, Rockford, Ill., was in town last week.
Geo. Linning, of Linning Bros., Peru, Ill., was here last week.
John F. Cook, Dowagiac, Mich., was a visitor here last week.
W. O. Stevens, with the Bay State Optical Co., is on a trip east.
Henry E. Cohen celebrated his 35th birthday on the 17th of March.
Ira L. Morgan, the only jeweler in Sidney, Ia., was in town last week.
F. W. Greene, representing the Hansen, Bennett Co., was here last week.
No examination into the affairs of Jos. Brown & Co. was held last week.
C. F. Collins, Dunbar, Nebr., was among the buyers in this city last week.
Frank T. Barton is on a visit to the factory of the Fontneau & Cook Co.
Geo. W. Bleecker, with the Martin-Copeland Co., is on a visit to the factory.
A. H. Williams, treasurer of the West Silver Co., Taunton, Mass., was here last week.
F. J. Neasham, traveler for C. H. Knights & Co., has removed from Ottumwa, Ia., to Nevada, Ia.
W. R. Boss, with the Standard Button Co., returned east last week, and is now on the sick list.
Fred. Kennon, of the John T. Mauran Mfg. Co., visited W. A. Fay, western representative of the company, last week.
D. N. Jacoby, representing the Providence Stock Co., and Max Jacoby, with the Manchester Mfg. Co., were here last week.
Herbert E. Cobb, with the Daggett & Clap Co., will take possession of room 405, Columbus Memorial building, May 1.
A cablegram from "Sam" Swartchild to his sons here last week announced the arrival of Mr. and Mrs. Swartchild in Rome, Italy.
The engagement is announced of Harry L. Sachs and Miss Fannie Emsheimer. Mr. Sachs is a brother of L. L. Sachs, of "Lucios."
W. H. Kee, with the Elgin National Watch Co., was recently taken ill at Redfield, S. Dak., and is now at his home in Elgin, Ill.
Mr. Shepard, of the Shepard Mfg. Co., Milton Highlands, Mass., was a visitor to

Chicago last week, as was Frank C. Hyde, Appleton, Wis.

C. T. E. Smith, with Reed & Barton, has returned from a week's vacation at West Baden. Mr. Smith gained "three ounces" in weight and is now quite stout.

O. W. Wallis, E. D. Buell and Harry Cutler, appraisers for the bankrupt estate of the National Jewelry Co., have been awarded \$15 each for their services.

News is received here that S. M. Thomas, a prominent retail jeweler of Tabor, Ia., was recently stricken with paralysis, and little hope is entertained of his recovery.

News was received here last week that H. H. Walker, formerly in the employ of C. D. McCoy & Co. at Minot, N. Dak., had opened a new jewelry store at Minto, N. Dak.

Royden Davis, son of W. C. Davis, an Elkhart, Ind., jeweler, was married in this city recently to Miss Alice Powers. Young Davis is employed with an electrical company in Chicago.

Among the out-of-town jewelers in this city last week not previously mentioned were: Carl G. Lindholm, Joliet, Ill.; Henry E. Volkman, Jr., Kankakee, Ill., and Samuel O. Adams, Polo, Ill.

P. B. Noyer, general manager for the Oneida Community, Ltd., and G. N. Allen, manager of the Niagara Falls silverware factory, visited the Chicago office of the corporation last week.

An inventory is being taken of the stock of the Shourds-Adcock-Teufel Co. An offer of \$35,000 has already been received for it, but it is believed that a much larger amount will be realized.

Among the diamond men here last week were "Sun" Englander, Cyrus Price, "Cy" Pickering, Otto Sinnauer, Albert Shire, "Phil" Noel, Robt. Steele, Neal Young, Sam Bowles and Mortimer Adler.

C. H. Knights was recalled from Cuba last week on account of the serious illness of his brother-in-law, who is a dry goods merchant at Seranton, Miss. Mr. and Mrs. Knights are now at the latter place.

W. A. Sturgeon, Detroit, Mich., spent a few days here last week. Mr. Sturgeon, in addition to carrying on a retail business in Detroit, will embark in the manufacturing jewelry business in the near future.

The receiver for the Madson-Steele Co., bankrupts, estimates the stock and accounts receivable to be about \$25,000, of which the accounts receivable amount to between \$8,000 and \$10,000. The liabilities are \$30,

000. Bids for the business will be opened March 20.

Clarence Crafters, of this city, is the name of a new corporation formed to manufacture jewelry and kindred articles, with a capital of \$6,000. The incorporators are R. D. Camp, C. D. Greene and J. H. Dunham.

Col. Wm. B. Keeler, of Chas. E. Graves & Co., who has been spending the Winter at Tarpon Springs, Fla., recently celebrated his 80th birthday. A vaudeville entertainment was given in his honor, and the citizens of Tarpon Springs vied with each other to do homage to him.

Albert W. Adcock, of the jewelry firm of Shourds-Adcock-Teufel Co., has been seriously ill at his home, 327 Warren Ave., with spine disease. Mr. Adcock, who is 61 years old, has been sick for the last two months. Dr. William White is in attendance since the bankruptcy petition against Mr. Adcock's firm, as noted last week, and Judge Landis appointed the American Trust & Savings Bank as receiver. Poor business during the recent financial flurry and inability on the part of the firm to collect its bills are said to have caused its failure.

Rudolph Bruening, representing the Schraeder-Wittstein Co., who, with his wife, has been on a trip to Europe, sailed for this country March 10 on the *Kronprinzessin Cecilie* of the North German Lloyd line, and expects to be back in Chicago this week. On his return he leaves at once for the road to visit his trade. Mr. Bruening has been away three months, and made a trip through France, Rivierra, Italy, Switzerland and Germany. To his friends in the trade Mr. Bruening says, though the trip he has taken is a beautiful one, he advises all those traveling for pleasure to travel more over the United States.

Warrants were sworn out last week for the arrest of J. A. Hope, of this city, on a charge of obtaining jewelry on memorandum from local dealers and not accounting for the same. Among the specific charges against Hope is that he obtained from Norris, Alister & Co. a four-carat diamond and a two and a half carat diamond, together valued at \$1,200, representing that he had a customer for the same and that he would report March 10. He failed to appear at the time agreed upon, and an inquiry brought to light the fact that he had disappeared from his boarding house, 2917 Prairie Ave. It was also claimed that on Dec. 20 he got three one-carat stones,

We Make Catalogs for the Retail Jeweler That Bring Results

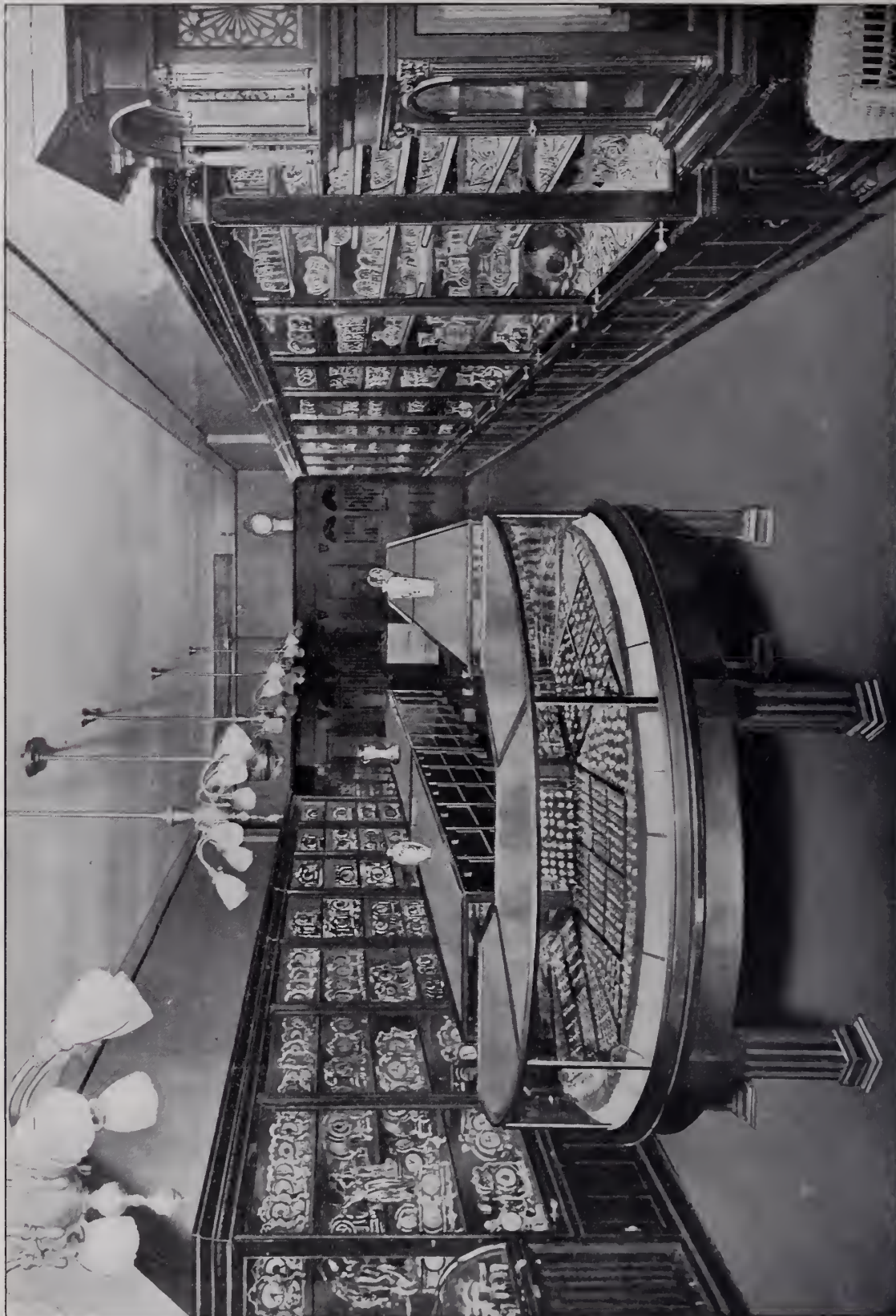

Write us at once for samples and particulars FREE

Our representatives visit nearly every State in the Union.

If you are interested, and will notify us, our representative will take pleasure in calling on you and explaining our method

THE ARNSTINE BROS. COMPANY

Originators of Our Exclusive Catalog Method for the Retail Jeweler

CLEVELAND, OHIO

IN WRITING US PLEASE MENTION THIS ISSUE "JEWELERS' CIRCULAR-WEEKLY"

STORE OF E. H. KORTKAMP JEWELRY CO., ST. LOUIS, MO.

(Copy of letter)

The Arnstine Bros. Company, Cleveland, Ohio.

St. Louis, Mo., January 20th, 1908.

Gentlemen. We desire to inform you, that the Catalogue furnished us by your House has certainly more than met our expectations. We consider this method of advertising as the very best for the Retail Jewelry business, and want to commend you on the style and general appearance of the Catalogue.
Yours very truly, E. H. KORTKAMP JEWELRY COMPANY.

valued at \$600, from H. W. Allen & Co., but on Feb. 20 he obtained stones worth \$1,025 from Dreyer, Lochau & Ohm Co., and that he also recently obtained two stones valued at \$425 from the S. F. Scott Co., and a stone worth \$250 from Roehr & Co. Hope, who is about 5 feet 10 inches high, of slender build and prematurely gray, for 10 years has been employed in the Chicago office of the Jewelers Board of Trade, and thus was no stranger with the jewelers with whom he dealt. It is said that he had ordered goods from a number of other firms, but these refused to deal with him. The day he disappeared Hope sent back a number of pawn tickets to the New York office of the Jewelers Board of Trade. These were immediately forwarded to the Chicago office.

Denver.

Henry E. Curtis, Littleton, was a buyer in this city last week.

Dan Weil, city salesman for T. C. Weil & Co., has just returned from a trip around Cape Horn.

R. H. Hart, Colorado Springs, Colo., was in this city for a few days last week, buying stock.

Fred Pettee, of the Waterbury Clock Co., was in town for a few days last week, visiting the trade.

Mr. Andrews, of Allsopp & Allsopp, Newark, N. J., was here last week in the interests of his firm.

Col. J. D. Lewis returned last week from Birmingham, Ala., where he has been conducting a large auction.

Syman Bros. have secured the contract for the Phi Epsilon Omega of the East Denver High School, to make their fraternity pins.

C. B. Lewis, of the Lewis Jewelers' Supply Co., returned from a successful trip through New Mexico and the southern part of Colorado, last week.

Joseph T. Schwartz narrowly escaped being swindled out of several hundred dollars' worth of goods, last week. A man who gave his name as Dr. Goodrich, came into the store with a couple of Mr. Schwartz's customers. The man asked to be shown some diamond bracelets, and other expensive jewelry, and said he wouldn't take anything then, but would be in the next day, when he returned and bought a \$50 ring, giving his check for it. Mr. Schwartz was suspicious of the man, so he had the pawnshops searched and found the ring in one of them on Larimer St. He then found that the check was worthless, and had the man arrested. The fellow was released later after a friend had settled the matter.

The Oates Jewelry Co., Little Rock, Ark., was recently destroyed by fire. The insurance money was garnisheed.

George A. Schilling, an Oswego (N. Y.) jeweler, was swindled out of two watches March 5 by a stranger who said he lived at 140 E. Bridge St., and who asked permission to take the watches to his home before making a selection. When the man failed to return, Schilling made an investigation and could get no trace of the swindler. The police have been notified.

Cincinnati.

Charles E. Kendall, with Richter & Phillips, leaves this week on his regular business trip.

Morris Plaut, of A. A. Spiegel & Co., has left on his business trip through Ohio and Michigan.

M. R. Shapira, formerly of Scranton, Pa., has located with Wallenstein, Mayer & Co. as watchmaker and jewelry repairer.

John Kinsler, formerly of Kinsler & Co., Covington, Ky., has connected himself with Joseph Mehmert as head material man.

Thomas Pritchett, of Henry & Pritchett, Hawkinsville, Ga., stopped over in this city last week on his way to Chicago and New York.

Harry Gilsey, of S. & H. Gilsey, is spending three weeks in St. Augustine, Fla., where he will umpire the ball game between the "Regulars" and the "Cincinnati Colts."

L. H. Becht, of A & J Plaut, was master of ceremonies last week during the annual inspection and banquet of Wyoming Lodge No. 186, F. & A. M., of which he is Worshipful Master.

Charles W. Hickok, with Graff, Washbourne & Dunn, is away from business owing to a serious illness. Mr. Washbourne was here last week to see Mr. Hickok, and is now continuing the latter's trip.

The Miller Jewelry Co. has received a contract to supply the Cincinnati Gymnasium with 88 gold medals and 12 silver loving cups for the open indoor carnival held March 14. C. J. Miller, of this firm, leaves this week on an extended business tour east.

The firm name of Herman E. Promnitz will be changed to the Herman E. Promnitz Co. on and after April 10. Charles H. Schmitt, for many years connected with the largest manufacturing jewelers of Cincinnati, will be a member of the firm. Mr. Promnitz will leave about April 10 for a sojourn in the southwest.

The National Jewelry Co., 12 Emery Arcade, has leased the adjoining store room and is now arranging to have the partition removed, which will give the concern much larger and more commodious quarters than it heretofore enjoyed. The company will also add new and more extensively to its various lines, and expects to have all improvements completed by April 10.

The Sinton Hotel, this city, has been selected as the place where the American National Retail Jewelers' Association convention will be held Aug. 3, 4, 5, 6 and 7. Present indications are that about 1,000 retail jewelers will attend the convention, and that the exposition, which will bring several hundred manufacturers and jobbers to the city, will be the largest of its kind ever held.

The E. Mahy Co. has changed its name to that of Mahy, Bowman Mfg. Co., having added E. S. Bowman, well known to the jewelry trade, as a partner. The company will do light manufacturing of jewelry in addition to the diamond-cutting business formerly carried on. It has also increased its capital and has made improvements in its factory and office which will enable the house to handle its growing business more satisfactorily. Mr. Bowman leaves this

week on a business trip through Pennsylvania.

Out-of-town jewelers here the past week purchasing stock included: Mr. Jenkins, Richmond, Ind.; E. Mueller, Hamilton, O.; Charles Diefenbach, Jr., Lewisburg, O.; Mr. Dumcanson, Lynchburg, O.; W. T. Eisen-smith, Charleston, W. Va.; Alvis Carr, La Follette, Tenn.; J. Wolf, Martin's Ferry, O.; Casper Fenzel, Middletown, O.; J. D. Ward, Rising Sun, Ind.; G. C. Hudson, Terre Haute, Ind.; Mr. Ramsey, Dixon, O.; Philip Stachler, Portland, Ind.; Herman A. Rohs, Cynthiana, Ky.; Edward Mutendorf, Williamson, W. Va.; O. E. McWaters, Somerset, Ky.

The Cincinnati Wholesale & Manufacturing Jewelers' Association met last Thursday evening, March 12, and elected the following officers under the new charter granted them upon the recent incorporation: President, A. G. Schwab, of A. G. Schwab & Sons; vice-president, Joseph Noterman, of Joseph Noterman & Co.; secretary, J. Charles Becker, manager of the local office of the Philadelphia Watch Case Co., and treasurer, Ed. H. Croninger. The Executive Board consists of S. Lindenberg, of Lindenberg, Strauss & Co.; Charles A. Nolting, of the Oskamp, Nolting Co.; Aaron Plaut, of A. & J. Plaut; D. J. Gutmann, of L. Gutmann & Sons, and J. S. Voss, Jr., of Joseph Voss & Sons.

San Francisco.

Geo. F. Blakeslee, Tonopah, Nev., is now in San Francisco.

Sigmund Hurtig has moved into new quarters at 414 Market St.

Alphonse Judis, of the Alphonse Judis Co., has just arrived from a visit to the east.

Chas. M. Robbins, of Chas. M. Robbins Co., has returned to the coast after a pleasure trip to Honolulu.

Among the recent visitors to San Francisco, Cal., were M. K. Giant, Vallejo, and George S. Adams, Sebastopol, Cal.

Arthur W. Van Ness, coast representative for the Wm. B. Kerr Co. and Link & Angel, is visiting the factories in the east.

Julius Wise, with J. S. Lehrberger & Co., who has been traveling in the east for the last month, is expected home next Saturday.

The employes of San Francisco wholesale houses have organized a baseball team, and will play their first game a week from next Saturday.

Radke & Co. have for some time been making deliveries by means of motor cars. They use three of the machines, which took a prominent part in the automobile parade, last week.

C. H. Linneman & Son, who have for several years been in Alaska, have returned to this city, and expect to open, in the near future, a large manufacturing plant, such as they formerly conducted.

Safe cracksmen recently made a bold attempt to rob the safe in the store of Richard Tlannondon, 135 Leland Ave. The force of the explosion was so great, however, that the thieves ran panic-stricken and secured only a nickel watch, which they threw away on the San Bruno road as they fled.

Fine Hand-Made Diagonal and End-Cutting Pliers



No. 2886. Plain, \$1.25

No. 2887. N. P., \$1.45

SWARTCHILD & COMPANY

Heyworth Building, Chicago

If you have not a copy of our double-sized 40-page Catalogue, write at once. Sent gratis upon application.

The Largest Exclusive Jewelers' Supply House in the World

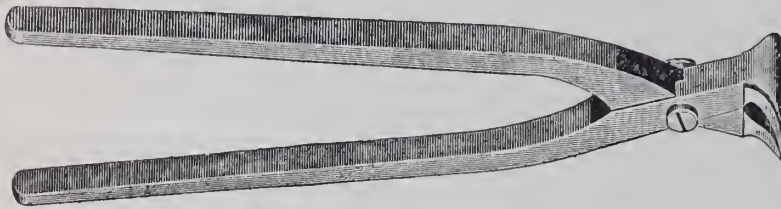

No. 2888. Plain, \$1.25

No. 2889. N. P., \$1.45



CAMEOS

IN these times the jobber, in order to stimulate his business, must create a run on some special article. And just now, why not the Cameo? It is sure to be a good leader and is being extensively advertised by a number of manufacturers.

We are mounting stone, shell and coral Cameos in scarf pins and brooches. A good assortment of Cameos should be found in every line this season. Let us send you a few samples on memorandum.

10K THIS TRADE-MARK on every piece of jewelry that leaves our factory. A medium-price line of 10K. jewelry that has stood the test. Will say no more, but let us show you and be convinced yourself.

Send for further information regarding our extensive line.

W. E. RICHARDS CO.
Manufacturers for the Jobbing Trade
ATTLEBORO, MASS.

New York Office: 12-14 John Street *Samples only*

Don't Worry About the Scarcity of Money

If you need any send us your surplus stock of Diamonds, Watches, Jewelry, Old Gold and Silver, and get our certified check by return mail. If amount is not satisfactory goods will be returned in same condition as received. Strictly confidential. Correspond or call. Telephone, 5202 John.

New York Jewelry Purchasing Co.
106 Fulton Street, New York

C. VAN SCHOOR

MANUFACTURING JEWELER AND REPAIRER

Best Workmanship. Lowest Prices. Jewelry Findings and Supplies. Importer of Jobbing Stones. Our findings are made of first quality, seamless stock, in all grades, direct from manufacturer to retailer. Our terms are cash. Give us a trial on repair work or send for booklet. Mail orders and repair work filled same day as received.

2041 W. 45th St., Cleveland, Ohio

WORKSHOP NOTES

For Jewelers and Watchmakers. Cloth. Postpaid \$2.50. Published by The Jewelers' Circular Publishing Co., 11 John St., New York.



Women of fashion are fickle. We cater to their whims. We now have on hand a large assortment of

COLLAR PINS

In Amethyst, Topaz, Jade and Turquoise.

These goods are of entirely new design and quite unique. They are within the reach of everyone—\$4.00 per dozen.

SELECTION PACKAGES SENT ON REQUEST

M. GUGENHEIM,

IMPORTER

Brooches, Festoon Chains, Combs, Hat Pins, Collars, Jet Goods, Mesh Bags, in German Silver, Gilt Metal and Sterling

NEW YORK OFFICE: 33 Union Square, Decker Building

PARIS: 32 Faubourg Poissoniere

Detroit.

TRADE CONDITIONS.

There is a genuine improvement in trade conditions although merchants are not yet buying as gely as a year ago. Detroit wholesalers report fair Spring trade and retailers say that the adual resumption of work in most branches of ade has made itself felt in increased purchases. ile there is a loosening of the purse-strings of e more well-to-do that makes the downtown res busier than was their wont. The financial ficulty of an up-State firm, noted elsewhere, is e first case of failure reported in the Michigan ade, this year.

W. F. King, Jr., Adrian, was in Detroit ecently.

O. H. Lutz, Ann Arbor, was in this mart recently.

Fred N. Pauli was here a few days o purchasing stock.

J. S. O'Rourke, Richmond, called on the cal trade recently to buy stock.

Chas. P. Hall, Saginaw, has been remodeling his store and getting in new fixtures. Hugo V. Stahle, with Noack & Gorenflo, is been ill during the past week with la rriple.

W. J. Bottomley, Brown City, has gone to eorgia, where he will enjoy a vacation of wo months.

A. B. Zierleyn & Co., Grand Rapids, have ade a proposition to compromise with heir creditors.

Marion Cobb, jeweler and optician, Freeport, is in town for a few weeks to take course in engraving.

George Weidig, manager of Jos. Fahys & Co., Chicago, was in this city, Wednesday and Thursday, of last week.

W. A. Sturgeon returned Monday of last week from a three weeks' trip to New York and left Thursday to go to Chicago.

M. Ehrlich has the exhibit of the Elgin National Watch Co. in his window, making a display which is attracting much attention.

Members of the Jewelers' Board of Trade vere invited to attend the Wednesday uecheon of the Wholesalers' Association in he Penobscot Inn.

Robert L. Weyhing, who has been away for two weeks on a trip for his firm, the Weyhing Bros. Mfg. Co., had the misfortune to be taken ill while out on the road.

Among the out-of-town jewelers not elsewhere mentioned who visited this city last week were: C. G. Draper, Plymouth; A. H. Kent, Mt. Clemens; Frank Preswell, Holly; George Carhart, Pontiac.

The Detroit Jewelry Mfg. Co., which has begun operations in the Rowland Block, has fine new quarters and an equipment of new and up-to-date machinery, with individual motors for each machine. Manager Fred J. Binder says that he has had to work overtime to fill orders during the first month of the new firm's existence. C. H. Purrenhage, Cleveland, is interested with him in the concern.

W. W. Bridges, Marine City, who recently returned from a long vacation in Oklahoma, has been describing that State as a promised land for the jeweler. "If I were to start anew I should choose such a field," he stated, while in Detroit, last week, on a buying trip. The business conditions there are reported good by him, and he states that the Indians of the eastern portion of the State are well-to-do and

spend their money freely for jewelry and personal decoration according to their ideas.

A school of watchmaking was discussed at the March meeting of the Detroit Jewelers' Board of Trade, Friday evening, in the Griswold House. So many men are now needed in this district for repairing and other watchmaking work that a trade school has become advisable. A committee has the matter in charge and progress is expected within a month. The project, taken up some time ago, of enlisting support for a national association of jewelry wholesalers was again to the fore. A committee report containing some changes in the circular prepared a couple of months ago was adopted, and steps will be taken to forward the organization, as the time seems more propitious than it was a few months ago. A draft of the new auctioneers' ordinance, applying only to personal property auctions, was approved and will go to the Wholesalers' Association for approval before being introduced in the common council. This measure is expected to do away with the nuisance of non-resident and bogus auctioneers. Some other important matters were discussed, but without definite action.

Minneapolis and St. Paul.

S. H. Clausin, Minneapolis, has returned from his Winter's sojourn in California.

Carl Damuth and wife, Redfield, S. Dak., have been in the Twin Cities on a business and pleasure trip.

J. C. Gerde, Paynesville, Minn., has been in the Twin Cities, looking up bargains in typewriters, which he has added as a side line.

Announcement is made of the marriage of Miss Leona W. Leber, daughter of W. C. Leber, Minneapolis, and Dr. Edwin Wanous. The ceremony will be performed April 8.

Cohen Bros. have not been able to complete the extensive remodeling work for their new location at 412 Nicollet Ave., Minneapolis, as early as they had hoped, but will soon be able to move.

Merchants of the east and south sides have taken steps toward restricting credits to a shorter time. Bills are regarded as due the first of the month succeeding the date of purchase, and if not paid by the usual time, such as the 10th of the month, or at the date of payday, if employed in some of the larger manufacturing or industrial concerns, the fact is regarded as sufficient to withhold further credit.

A daring robbery was committed at the Fisk-Johnson Jewelry Co.'s store, in Minneapolis, last week. A stranger asked to see diamonds, and, after examining them carefully, selected a number of stones, and tendered in payment several bills, including one for \$500, five \$100 bills, a \$50 bill and \$24 in \$1 bills. The jeweler counted the amount and found it to be \$1 short, and the pseudo "Mr. Maurice," of New York, as he introduced himself, produced another \$1 bill, which he added to the pile of currency, but by some sleight-of-hand work, in placing the last bill upon the lot, he withdrew the large bills, leaving only the \$24 in \$1 bills. The act was not detected until after he had gone, when a recount showed only \$25 instead of \$1,075.

Indianapolis.

G. A. Fogas is recovering from a serious illness which it was feared for a time would prove fatal.

William Moore Smith, Jamestown, was married a few days ago to Miss Beatrice Jacks, at the bride's home, near Fairland.

A business trip to Richmond and territory in northeastern Indiana was made, last week, by A. P. Craft, of the A. P. Craft Co.

Quite a number of retail jewelers were in this city last week buying stock. Among them were C. H. Ankeny, Lafayette; F. Pennington, Knightstown; A. H. Pauley, Bloomington, and A. S. Orr, Greenfield.

Frank L. Bryant has returned from a six weeks' trip to California and other western points and is precariously ill. While returning he was stricken with inflammatory rheumatism on the train. Mrs. Bryant accompanied him on the trip.

Ralph B. Clark, Anderson, president of the Indiana Retail Merchants' Association, will address members of the Indianapolis Retail Jewelers' Association and their friends in the directors' room at the Commercial Club, on the evening of April 6 or April 13. All persons interested in the jewelry trade will be asked to attend.

As a special committee of the Indiana Retail Jewelers' Association, J. P. Mullalley, J. H. Reed and H. H. Bishop held a meeting one night last week to investigate whether or not it was necessary for the association to incorporate. The committee was informed that such a step was unnecessary and the association will not be incorporated.

The Indianapolis Retail Jewelers' Association has under consideration the matter of establishing a schedule of prices for special professional services rendered by jewelers and diamond merchants of the city. In the past no charge has been made for estimating the value of jewelry or diamonds brought to them, but it is now proposed to charge two per cent. of the value for the service. A special committee composed of J. H. Reed (chairman), George S. Kern, Mr. Gray and President J. P. Mullalley has the matter in charge.

Pacific Coast Notes.

R. A. Moore, Santa Barbara, Cal., has remodeled his store, making it one of the handsomest in that city.

The Santa Barbara Jewelry Co., Santa Barbara, Cal., has been dissolved. The business will now be continued by Frank Field.

H. E. Denton, Colusa, Cal., has moved his stock to the first building east of the Lompoc Commercial Co. The quarters have been remodeled and fixed up especially for Mr. Denton's use.

A. G. Perham, a jeweler who has been in business at Ontario, Cal., has bought the balance of the bankrupt stock not sold at auction, formerly owned by C. D. Grandmason, Ocean Park, Cal.

By climbing over roofs of buildings in the center of the Broadway and Franklin St. business section of Oakland, Cal., a burglar entered the rear of a store conducted by C. F. Salomonson, 1057 Franklin St., recently, and robbed the place of \$300 worth of jewelry and money.

Los Angeles.

Joseph Rittigstein has decided to remain in his present location, 427 S. Broadway, until Jan. 1.

Philip Klein, who recently opened a branch store in San Francisco, has gone into the wholesale business on 4th St. in this city.

Both members of the firm of Hambright & Walsh have been out on the road recently, and report having secured a good share of Spring business.

C. W. Ernsting, of the Ernsting Co., San Diego, is in the city getting ideas for his optical parlors, to be opened shortly in connection with his jewelry business.

George Kryhl, Santa Ana, has been here for several days making purchases among the wholesalers. H. E. Rader, Monrovia, has also been here buying new stock.

V. D. Mitchell, a watchmaker, who was sent to San Quentin prison for having shot his wife's mother, has sent here for his tools, expecting to make use of them in the prison.

R. H. Schwarzkopf, of Schwarzkopf & Penniman, is home from his eastern trip and expects to remain for some time. His partner, G. L. Penniman, has returned from a recent trip to San Francisco.

The H. J. Whitley Co. furnished the sterling silver loving cup presented by the Los Angeles Times to Leon T. Shettler as one of the trophies awarded in the recent Pasadena-Altadena automobile hill climb.

The Los Angeles-Pacific electric railway management has transferred its watch inspectorship from Luckenbach & Co. to S. Nordlinger & Sons. The latter company are also inspectors for the Southern Pacific Co.

The stock of the Ten Chong Co., Chinese jewelry and curio merchants, 610 S. Broadway, is being sold at auction. The store must be vacated on account of the decision of the owners of the property to build a new 19-story building.

H. A. Forbes, coast agent for the Dueber-Hampden Watch Works, is making his headquarters here while establishing retail agencies. Ed. Willis, the new jeweler at Hollywood, a suburb of this city, has been appointed by Mr. Forbes, to represent his company there.

The business recently conducted by C. W. Cleveland at 308 W. 7th St. has been bought by Louis Richbart, who will increase the stock and introduce in connection with the jewelry business a loan department. Mr. Richbart has been engaged in the real estate business in this city.

Manager Adams, of the J. P. Trafton Co., has been very busily occupied during the last two weeks getting settled in the company's new store at 424 S. Broadway. The store will be one of the handsomest and most convenient wholesale jewelers' establishments in the west.

The contract for furnishing the invitations and menu cards for the occasion of the banquet given by citizens of Los Angeles to the officers of Rear Admiral Robley D. Evans' fleet on their arrival here has been awarded to Montgomery Bros. There was a spirited contest for this work. It was awarded in consideration of the character of work to be furnished, entirely regardless

of price. The work comprises three articles, an invitation to the officers, 60 in number, and to prominent citizens, 200 in number, and the menu and toast list. Both invitations are made in steel die work, the engraving being in shaded French script. They will bear the Los Angeles flag in colors at the top of the first page as emblematic of the city and a fine engraving of the San Gabriel mission near the bottom as representative of southern California. The invitations contain the names of the committee of entertainment of officers, headed by that of Lieut-Gen. Adna R. Chaffee, retired, who is now a resident of this city. The banquet is to be a very elaborate one, each of the citizen guests to pay \$25 a plate. These invitations and menus will much exceed in cost any such work ever done on this coast. The work will all be done in Montgomery Bros.' establishment.

Omaha.

C. L. Shook went to Hastings, Nebr., last week on business.

L. A. Boyson, with C. B. Brown Co., is on a hunting trip in Wyoming.

F. M. Nelson, with Albert Edhohn, is at Chapman, Nebr., on a hunting trip.

Geo. W. Ryan, of the Mawhinney & Ryan Co., spent a few days of last week in Shenandoah, Ia.

Mr. and Mrs. Alden, Hyannis, Nebr., were in this city last week visiting friends and buying stock.

E. E. Thomas, with the Milwaukee Optical Mfg. Co., spent a few days of last month in this city.

C. W. Ferguson, Humphrey, Nebr., has sold his jewelry interests and is visiting relatives in Kirksville, Mo.

Fred CATERON, formerly with the C. L. Shook Mfg. Co., but now located in Kansas City, Mo., was here for a few days of last week.

Mr. Mapes, Craig; Ed. McComas, Broken Bow; Roy Smith, Lincoln; O. G. Tureen, Lyons; A. H. Lewis, Sutton; Harry Dixon, North Platte; John W. Crabill, Plattsmouth, and J. W. Eggers, Atlantic, Ia., were in this city last week purchasing stock.

Milwaukee.

The stock of Max Schucht, the bankrupt jeweler, 5th and Vliet Sts., was sold at auction Saturday, March 14.

August Bringe, 517 12th St., whose clock was among those destroyed recently, placed a shining alarm clock on the spot once occupied by an elaborate street clock, and hung a sign over it bearing the inscription, "Hitch Horses Here."

David Goldman is trying to secure an injunction restraining the city authorities from preventing him from re-erecting his clock. The clock was torn down after Mr. Goldman had been given verbal notice, and he claimed he should have had written notice. The authorities said that he had never received a permit to erect a clock. Judge Williams has not yet given a decision.

Frank Harder, who had been employed by Geo. W. Hess, Bloomsburg, Pa., is now manager at Mrs. Martin's store, which is about to be moved to the Sharpless building.

Kansas City.

J. B. Schmeltz and wife have just returned from a short sojourn at Excelsior Springs, Mo.

L. White, with the Ward & Crellin Jewelry Co., was a visitor to the house for a few days last week.

Sam Bloom, with the Meyer Jewelry Co., has been paying the house a short visit but is again out covering his territory.

Leo Ludwig, of the Edwards & Sloane Jewelry Co., sold his home last week with the intention of buying a larger residence.

W. H. Pontious, with F. E. Pirtle & Co., Anthony, Kans., was in this city last week on his way to Excelsior Springs for a rest.

J. H. Whitney, with the Edwards & Sloane Jewelry Co., spent a few days of last week in the house, but is again in the territory.

The Kansas City Jewelry and Optical Jobbers' Association held its first meeting and dinner of the season Friday evening March 13.

George Thompson, formerly with the Meyer Jewelry Co., and who later went to Colorado, is now with D. D. Williams & Co., Emporia, Kans.

George H. Edwards, of the Edward & Sloane Jewelry Co., has just returned from Bloomington, Ill., where he was called by the serious illness of his father, Richard Edwards, who died Sunday of last week aged 86 years.

George Roemer, of the Green Jewelry Co., has the sympathy of his friends in the trade on account of the recent death of his father. The funeral was held Wednesday at which time the Green Jewelry Co. closed its store.

Louis Meyer, of the Meyer Jewelry Co. contemplates building a five-story building on his property on 11th St., between Wyandotte and Central. This property will be improved, however, for rental purposes, and not for occupancy by the Meyer Jewelry Co.

H. H. Jeffreys, formerly with the Green Jewelry Co., has organized a new company to be known as H. H. Jeffreys & Co., and has purchased the business of F. E. Kaise, 527 Minnesota Ave., Kansas City, Kans. where they will do jewelry manufacturing and diamond setting.

The following out-of-town jewelers were in this city during the past week: P. J. Broderson, Douglas, Kans.; F. A. Wesel, Holyrood, Kans.; F. R. Cullumber, Elkhart, Mo.; George Spangle, Chetopa, Kans.; I. Leighty, Springhill, Kans.; E. V. Le Louisburg, Kans.; J. A. Inglis, of Inglish, Huber, Higginsville, Mo.; W. H. Pontious, Anthony, Kans.; H. C. Hansen, St. Mary, Kans.; H. L. Morrison, Pittsburg, Kans.; W. F. Moser, LaCrosse, Kans.; J. C. F. man, Salisbury, Mo.; G. E. Read, Lebanon, Mo.; W. S. Ahutt, Richmond, Mo.; C. Iron, of C. Iron & Son, Parker, Kans.; J. Megede, Richmond, Mo.; Jos. Barbork, Clinton, Ia.; Mr. Stuhl, McCook, Nebr.; J. B. Heifner, Missouri City, Mo.

The Western Union Telegraph Co. recently placed new clocks in a number of prominent buildings at Catasauqua, Pa., including the store of James C. Beitel & So

INDEX TO ADVERTISEMENTS.

sopp Bros.	22	Heller, L. & Son.	50	Prior, Charles M.	106
vin Mfg. Co.	Inside front cover	Herpers Bros.	106	Racine, Jules, & Co.	101
erlean Gem & Pearl Co.	58	Hight Mfg. Co.	106	Randall, C. Ray.	17
erlean Platinum Works.	112	III & Schmidt.	26	Ranlett & Lowell Co.	99
erican Watch Case Co.	84	Himalaya Mining Co.	48	Reichhelm, E. P., & Co.	106
chibald-Klement Co.	26	Hirsh & Hyman.	56	Reichman, A.	61
lzaon Turquoise Mines Co.	50	Hodenpyl & Walker.	52	Reuzelhausen, W. F., & Co.	112
nsteln Bros. & Co.	10	Hoffman Novelty Co.	34	Revell, A. H., & Co.	119
nstline Bros. Co.	74	Hooper, H. J.	82	Rice's, Bernard, Sons.	114
stln, John, & Son.	84	Hotel St. James.	34	Richards, J. M.	58
erbeck, M. J.	31	Howard, E., Watch Co.	94-95	Richards, W. E., Co.	76
gg & Co.	54	Hraba, Louis W.	114	Richardson, Enos, & Co.	24
ker, Geo. M.	112	Hyde & Co.	98	Robbins, Chas. M., Co.	15
ll, Webb C., Watch Co.	96	Illinois Watch Co.	72	Roger Williams Silver Co.	29
schkopf, Henry.	22	International Gem Co.	60	Rohrbeck, John E.	28
ssett Jewelry Co.	32	Irons, Joseph.	110	Roseman, A.	60
tes & Bacon.	16	Irving Cut Glass Co.	108	Roy Watch Case Co.	86
erge, J. & H.	112	Jacot Music Box Co.	114	Rudolph & Snedeker.	100
ings, Chester, & Son.	52	Jantsehek Co.	113	Rumpp, C. F., & Sons.	108
shop, R. W.	110	Jeanne, F. A.	46	Saart, W. H., Co.	17
ackinton, R., & Co.	12	Jorgeson, F. C., & Co.	84	Saunders, Meurer & Co.	56
olles, Wm., Co.	108	Juergensen, Jules.	100	Schultz & Co., Inc.	29
orrell & Vitell.	58	Kahn, L. & M., & Co.	40	Sessions Clock Co.	100
owden, J. B., & Co.	22	Keller Jewelry Mfg. Co.	26	Shepard Mfg. Co.	62
radley Polytechnic Institute.	101	Kent & Woodland.	27	Simmons, R. F., Co.	21
riggs, D. F., Co.	20	Ketcham & McDougall.	33	Smith, Alfred H., & Co.	46
riggs Plano Co.	110	Keystone Watch Case Co.	92	Smith, Frank W., Co.	18
rynes, Townsend & Swenarton.	84	Khney Co.	63	Smith, Wm., & Co.	30
arter, Howe & Co.	25	Kirby, H. A.	66	Snow & Westcott Co.	26
atham National Bank.	70	Kohlbusch, Herman, Se.	106	Sohn, & Hyman.	62
hicago Art Metal Works.	30	Kohn, Alois, & Co.	25	Solderine Co.	106
hopard Frères.	28	Kremetz & Co.	23	Solidarity Watch Case Co.	18
incinnati Gold & Silver Refining Co.	70	Krower, Leonard.	31	Spencer, E. L., Co.	29
onley & Straight.	113	Langendorf Watch Co.	99	Star Watch Case Co.	6
ottle, S., Co.	27	Larter & Sons.	38	State Bank.	68
rees & Court.	33	Lederer, S. & B., Co.	32	Steiner, Louis.	108
rohu, M.	31	Lelman Bros.	106	Stern & Corn.	30
ross & Beguelin.	52, 63	Lelong, L., & Bro.	106	Stern Bros. & Co.	56, inside back cover
rossman Co.	61	Lewy & Cohen.	114	Sternau, S., & Co.	14
rouch & Fitzgerald.	31	Lisner, D., & Co.	14	St. Louis Watchmaking School.	99
ay, Clark & Co.	27	Lissauer & Co.	56	Street, Geo. O., & Sons.	27
eacon, Louis J.	22	Lorsch, Albert, & Co.	40	Sussfeld, Lorsch & Co.	100, 114
ederick's, James H., Sons.	84	Lowe, Edwin, & Co., Inc.	30	Swartchild & Co.	76
Dixon, Wm., Inc.	112	Maintien Bros. & Elliot.	32	Tavannes Watch Co.	101
boran, Bagnall & Co.	31	Market & Fulton National Bank.	68	Theberath & Co.	25
ordfinger, C., & Sons.	108	Marson, A.	113	Title Guarantee & Trust Co.	68
Draper, O. M., Estate.	33	Mercantile National Bank.	69	Trout, Charles L., & Co.	26
Dubois Watch Case Co.	96	Meyerowitz Bros.	42	Untermeyer-Robbins Co.	61
Dueber-Hampden Watch Mfg. Co.	10	Miller, Fuller & Whiting Co.	33	Urich, S.	101
Dunn, T. J., Co.	28	Mount & Woodhull.	54	U. S. Smelting & Refining Works.	112
Durand & Co.	24	Murray, Dan, I.	83	Van Dam, Eduard.	42
Elchberg & Co.	60	Myers, J. A.	82	Van Dusen & Stokes Co.	19
Eisenmann Bros.	52	Myers, S. F., Co.	30	Van Schoor, C.	76
Elgin National Watch Co.	90	Nassau Bank.	68	Wachter Mfg. Co.	101
E. P. H. Chain Catch.	32	New England Watch Co.	99	Wadsworth Watch Case Co.	9
Eveson Co.	82	New York Jewelry Purchasing Co.	76	Wagenführ, Chas.	32
Fahys, Joseph, & Co.	3	New York Standard Watch Co.	97	Waite-Thresher Co.	34
Feldenheimer, Louis.	62	Nissen, Ludwig, & Co.	54	Waldron & Carroll.	60
Foster, Theodore W., & Bro. Co.	36	Noel, Rudolph, & Co.	46	Waltham Clock Co.	100
Freund, Henry, & Bro.	19	Oneida Community, Ltd.	Outside back cover	Waltham Watch Co.	88
Friedlander, R., L. & M.	42	Oppenheimer Bros. & Veith.	42	Washburn, C. Irving.	33
Galaway, J. H. & F. H.	26	Oppenheimer, H., Z. & H.	44	Wells, Chester H.	31
Garraud, & Griser.	22	Oskamp-Nolting & Co.	28	Wendell & Co.	7
Gillette Sales Co.	35	Osmers-Dougherty Co.	27	Wheeler, Hayden W., & Co.	46
Goodfriend Bros.	50	Osmun-Parker Mfg. Co.	24	Whiting & Davis.	15
Gorham Co.	64	Ostby & Barton Co.	16	Whiting Mfg. Co.	13
Griffoul, August.	30	Owanda Cut Glass Co.	108	Wightman & Hough Co.	30
Groen, H. A., & Bro.	70	Papazien, A. D.	98	Wolcott Mfg. Co.	8
Gugenheim, M.	76	Patek, Philippe & Co.	98	Wolfshelm & Sachs.	28
Hagstoz, T. B., Ltd.	112	Penfold, Wm. C., Co.	96	Wollstein, L. & M.	112
Hammel, Riglander & Co.	11	Pitcairn, W. S.	110	Wood, Chas. F., & Co.	52
Harris & Harrington.	98	Pitzele, S.	28	Wood, J. R., & Sons.	4, 5
Hedges, A. J., & Co.	22	Potter & Buffinton Co.	29	Zarembowitz, A.	98
Hedges, Wm. S., & Co.	56	Potter, E. A., & Co.	20	Zimmer, Henry, & Co.	113

Special Notices.

Payable invariably in advance.

Rates 75c. per insertion for notices not exceeding 25 words; additional words, 2c. each.

SITUATIONS WANTED, 1c. a word each insertion; minimum charge, 25c.

Heavy type, 5c. a word; minimum charge, \$1.25. Display cards, \$2.00 per inch.

In all cases, if answers are to be forwarded, 10c. extra to cover postage must be enclosed.

All answers to advertisements addressed care *The Jewelers' Circular-Weekly*, should be sent to the New York Office, unless the Chicago Office is specifically mentioned.

Situations Wanted.

ENGRAVER and saleslady, experienced; best of references. Address "L., 3514," care Jewelers' Circular-Weekly.

ENGRAVER, experienced on gold, silver and stationery dies. "H.," 201 Chestnut Ave., Jamaica Plain, Boston, Mass.

ASSISTANT WATCHMAKER, engraver and optician wants position; best reference. "H. B.," 1013 S. 3d St., Elkhart, Ind.

THOROUGH, practical, rapid and experienced watch repairer, disengaged April 1. J. A. Coon, 548 Warren St., Hudson, N. Y.

A JEWELER and setter wants to get a position, can do engraving. Xaver Langenwalter, third floor, 300 E. 83d St., New York.

POSITION WANTED by engraver; all kinds of lettering and monograms; references given. Urban Dean, Cameron Mills, N. Y.

EXPERIENCED silverware and jewelry salesman, road or retail, retail preferred. Address "R., 3594," care Jewelers' Circular-Weekly.

FIRST CLASS jeweler, designer, composer and finisher wants steady position. Address "J., 3659," care Jewelers' Circular-Weekly.

WATCH and clockmaker, young man, wishes position; salary, \$12 per week; best reference. John Hofmeier, 41 W. 128th St., New York.

DIAMOND SETTER wants situation, experienced on platinum work; town or country. Address "A. E.," care Cooper, 457 Lexington Ave., New York.

FIRST CLASS jewelry engraver and salesman is open for position. Address "W., 3678," care Jewelers' Circular-Weekly, Heyworth Bldg., Chicago, Ill.

FIRST CLASS diamond setter on fine jewelry desires position at once; no objection to going out of town. Address "E., 3523," care Jewelers' Circular-Weekly.

WATCHMAKER and engraver, of long experience, no jewelry repairing; reliable firm only; all references; state particulars. F. Lanc, Evansville, Ind.

YOUNG MAN wishes position as salesman, order or stock clerk, in wholesale, retail jewelry or silver house. Address "X., 3692," care Jewelers' Circular-Weekly.

WANTED, position in south or west by jeweler or second watchmaker, good on new or repair work; best references. "A., 3675," care Jewelers' Circular-Weekly.

OPTICIAN, first class refractionist and jewelry repairer, age 22, four years' experience, wishes position; reference. Address "K., 3691," care Jewelers' Circular-Weekly.

YOUNG MAN, 9 years' experience in retail jewelry business, desires position in retail or wholesale house; willing to travel. "K., 3510," care Jewelers' Circular-Weekly.

FIRST CLASS watchmaker, 15 years' experience, desires position; capable of repairing and adjusting high grade work. Address "R. A. L.," General Delivery, Utica, N. Y.

FIRST CLASS watchmaker, with tools, desires position at once; middle age man; competent to handle railroad work. Address "E. H. B.," 45 Charles St., Springfield, Mass.

YOUNG MAN wishes steady position as watchmaker and engraver; can handle musical instruments; first class references. Address "E., 3705," care Jewelers' Circular-Weekly.

DESIGNER on class pins, medals, badges and fraternity pins, desires position with reliable house; can make attractive sketches. "C., 3676," care Jewelers' Circular-Weekly.

EXPERIENCED watchmaker and engraver would like permanent position in first class store, desires a change; east preferred. Address "A. R., 3645," care Jewelers' Circular-Weekly.

WANTED, a situation as watchmaker; 20 years' experience with best of reference; nothing but a first class position will be considered. Address Chas. E. Palmer, 29 South St., Waltham, Mass.

ENGRAVER; experienced letter and monogram engraver, could assist on clocks, open for position April 1; young man, very best reference. Address Box 3587, care Jewelers' Circular-Weekly.

MELTER, experienced, gold or silver, practical at preparing stock, solutions, alloys, solders, etc., handy with drop hammer or presses, also coloring. Address "J., 3680," care Jewelers' Circular-Weekly.

YOUNG MAN, 25 years, speaks German, French and English, and well acquainted with imported white stone jewelry, wants position; best references. "O., 3711," care Jewelers' Circular-Weekly.

SITUATION WANTED by first class watchmaker, salesman and optician; capable of managing; 21 years' experience, 36 years old, single; all reference. Address "R. J., 3722," care Jewelers' Circular-Weekly.

WATCHMAKER, 20 years' experience in factories and stores, able to take charge of repair department or store, is looking for situation. Address "Watchmaker, 3681," care Jewelers' Circular-Weekly.

ENGRAVER, young man, desires position with first class engraver, or an opportunity to learn watch work; good script letterer; samples on request; all reference. "D., 3602," care Jewelers' Circular-Weekly.

FIRST CLASS watchmaker, thoroughly competent, repairs any watch rapidly; expert on all complicated watches; 29 years' experience; good references. Address "F., 3707," care Jewelers' Circular-Weekly.

BOOKKEEPER, double entry, 20 years with present employer, owing to firm retiring from business May 1, am open for engagement; best reference. Address "G. T. L., 3650," care Jewelers' Circular-Weekly.

THOROUGH, high class watchmaker, jeweler and engraver, 28 years' experience with all firms, complete set of tools and references, now open for engagement. "X. L., 3708," care Jewelers' Circular-Weekly.

WANTED, position as traveling salesman for manufacturer or jobber by young man; prefer western territory; 12 years' experience in jewelry business. Address "G., 3615," care Jewelers' Circular-Weekly.

A FIRST CLASS WATCHMAKER, with many years' experience in high grade adjusting and complicated watch work, wishes to make a change in his position. Reply to Nils Zetterquist, 70 Columbus Ave., Waltham, Mass.

FIRST CLASS all around jeweler, having thorough experience of fine diamond mountings and all kinds of repairing and setting, wishes position; will go anywhere; best references. "F., 3632," care Jewelers' Circular-Weekly.

YOUNG MAN, 25, traveling, would like to introduce in Ohio, Kentucky and West Virginia, a line of high grade jewelry or silverware, manufacturer's line preferred. Address "N., 3685," care Jewelers' Circular-Weekly.

POSITION WANTED as salesman and buyer of silverware; capable of handling departments of fine stationery and leather goods; can furnish finest New York City references. "E. S. T., 3687," care Jewelers' Circular-Weekly.

WATCHMAKER, 20 years' experience on high grade watches, accustomed to taking in and delivering work, desires good position with high class jeweler; not an engraver. Address "R. N. Y.," 11 S. Union St., Rochester, N. Y.

A FIRST CLASS watchmaker, 25 years' experience on high grade American and Swiss watches, wishes a steady position; can start at once in vicinity of New York City. Address "K., 3541," care Jewelers' Circular-Weekly.

THOROUGHLY competent, first class watchmaker wants position; 28 years' experience on all kind of watches; good set of tools; best references \$20 weekly; only New York or vicinity. Address "Y., 3717," care Jewelers' Circular-Weekly.

TRAVELING SALESMAN desires change; highest reference, with good trade in Pennsylvania, New York, Ohio, Michigan, Illinois, Missouri and Massachusetts; commission or salary. Address "G., 3710," care Jewelers' Circular-Weekly.

YOUNG MAN, 19, with experience in jewelry repairing, wishes position in a store or factory would like to learn watchmaking; no objection to leaving city; active, good references. Address "Trustworthy, 3662," care Jewelers' Circular-Weekly.

HIGH CLASS MANAGER, can do bench work and engraving, also refractionist; \$100 per month up; south or west; trade winner with stiff references; permanent place wanted. "O., 3593," care Jewelers' Circular-Weekly, 501 Heyworth Bldg Chicago, Ill.

WATCHMAKER, many years' experience, desires a good position with first class jewelers on high grade clocks, such as French clocks, travel clocks, etc.; also able to assist at good all around watch repairing. "B., 3703," care Jewelers' Circular-Weekly.

A YOUNG MAN wishes a position in New York as an optician and jeweler, 23 years old, has six years' experience in Boston; own tool salary, \$18 weekly; can come well recommended. Address "B. H. G., 3656," care Jewelers' Circular-Weekly.

GRADUATE refractionist and good jeweler thoroughly experienced, desires position; can work trade, give estimates on all jewelry and repairs, etc.; left last position of my own accord. References. "Refractionist, 3724," care Jewelers' Circular-Weekly.

BY A FIRST CLASS manufacturing jeweler an diamond setter, also an all repairer and a around man; young, sober and reliable, with good recommendation; northwestern States; retail stores only need apply. Address Robert W. C. Pfaeffle, Enid, Okla.

YOUNG WOMAN, eight years' experience in wholesale jewelry business, bookkeeping, carrying of stock, filling orders, selling office trade, competent to assume entire charge; best reference would leave town. Address "B., 3638," care Jewelers' Circular-Weekly.

YOUNG LADY, thoroughly familiar with jewelry business, all saleswoman, capable, wishes position of trust and responsibility, where merit will be appreciated, with wholesale or retail concern. Best references. Address Miss Hanna H. Witt, 218 W. 138th St., New York.

AT ONCE, by German, all around man, watchmaker, jeweler, engraver and stone setter, prefer jewelry repairing, engraving, stone setting, window trimming, etc.; steady position, notch wages; steady, sober, reliable. W. Lambert, Box 379, Lafayette, La.

SALESMAN, recently covering south and west for well known jewelry house, desires position in like capacity, or would consider good lines in commission for Pacific coast trade; best of references; communications confidential. Address Box 3671, care Jewelers' Circular-Weekly.

WANTED, by a young woman, a position with either a wholesale silver house or as manager of the silver department in a jewelry business. I can make herself useful in any or all departments. 12 years' experience; best references; location immaterial. Address "P., 3595," care Jewelers' Circular-Weekly.

SALESMAN, of intelligence, good habits and well recommended is open for engagement; sold general line in Ohio and Pennsylvania; well acquainted in large towns and cities; east or west with jobber or retailer; manufacturer's line preferred. Address "Opportunity, 3719," care Jewelers' Circular-Weekly.

FIRST CLASS watchmaker would like permanent position with good, reliable house; had 25 years' experience, married, American, 44 years old, first class tools, has worked for the trade; expert on watch jewelry, staff making, pivoting, etc. get close time out of watch. "P. K., 3729," care Jewelers' Circular-Weekly.

YOUNG MAN, 24, single, desires permanent position; first class watchmaker, plain engraver a graduate optician; can act as salesman when necessary; own bench and tools, including lathe etc.; moderate salary; six years' experience Georgia or Tennessee preferred. Address "3516," care Jewelers' Circular-Weekly.

SITUATIONS WANTED.—Continued

FIRST CLASS watchmaker, fine letter and monogram engraver and graduate optician; 23 years' experience, five years on railroad watches; several years in present position; do not repair clocks or jewelry; would not go east of Indiana; own, \$600 to 25,000; first class references. Address "S. J., 3623," care Jewelers' Circular-Weekly.

Side Lines Wanted.

WANTED, up-to-date manufacturer's line 14K jewelry to be sold on commission in territory west of Salt Lake City; established trade with leading jewelers; headquarters at San Francisco; best of references. Address "P., 3715," care Jewelers' Circular-Weekly.

Help Wanted.

GOOD MAN wanted for watchwork and salesman Aberdeen, S. D., by Voedisch Jewelry Co.

JEWELSMAN wanted on commission for a 14 karat line of jewelry, suitable for retail trade. Address "B., 3672," care Jewelers' Circular-Weekly.

WANTED, watchmaker, must be fine workman; address with past three years' complete references. Greenleaf & Crosby Co., Jacksonville, Fla.

WANTED, salesman calling on jewelry trade to handle side line of first class jewelry boxes; liberal commission. Horton Box Co., Buffalo, N. Y.

WATCHMAKER; assistant watchmaker for large store in northern New York; salary between \$14 and \$15. Address "P., 3673," care Jewelers' Circular-Weekly.

WANTED, jeweler with knowledge of refraction; good position, good pay; give general description in first letter. I. Wartell, 513 E. Tremont Ave., Bronx, N. Y.

WANTED, young man with store experience to repair watches and jewelry; wages \$15 per week; job permanent. Address "Permanent, 3731," care Jewelers' Circular-Weekly.

A CAPABLE OPTICIAN, who can do all kinds of refraction work, edging, drilling, etc., good salary and commission. Address "U., 3689," care Jewelers' Circular-Weekly.

FIRST CLASS watchmaker and engraver to take charge of watch department; steady position; send references, state age, experience and salary wanted. S. Spitz, Santa Fe, N. M.

WANTED, three or four first class diamond polishers. Address, "D., 3690," care Jewelers' Circular-Weekly.

WANTED, a first class watchmaker, jeweler, plain engraver, also optician, one who can wait on trade; must have good references; steady position; state salary wanted. D. M. Rinaldo, Hot Springs, Ark.

WANTED, jeweler and engraver with store experience and competent to wait on fine trade; steady position to an American of good appearance. Address "T., 3657," care Jewelers' Circular-Weekly.

ENGRAVER, first class, to take charge of engraving department; one who can do chasing, enamel cutting and designing; must be sober and industrious. E. H. Warnke & Co., Enterprise Bldg., Milwaukee, Wis.

WANTED, first class watchmaker, optician and engraver; permanent position to the right man in one of the growing cities of the southwest; population about 20,000. Address "A1, 3524," care Jewelers' Circular-Weekly.

AT ONCE, young man for jewelry and clock repairing and engraving; good opportunity to finish watchmaking under competent watchmaker; state experience and wages wanted in first letter. Oppenheimer Bros., 578 Broadway, Kingston, N. Y.

FIRST CLASS watchmaker and engraver; must be an A1 letter and monogram engraver, sober and not afraid of work; we have a permanent position for the right man; state wages wanted, references, etc., in first letter. Frank C. Hyde & Co., Appleton, Wis.

STERLING NOVELTIES and small sterling hollow ware; salesman with practical ideas as to salable goods wanted for large western trade; previous experience in this particular line absolutely necessary. Address "Manufacturer, 3728," care Jewelers' Circular-Weekly.

WANTED, by first class house in large Texas city, first class jeweler and engraver on new work and repairs; permanent position, good salary; send samples of engraving and copy of references in first letter. Address "L., 3694," care Jewelers' Circular-Weekly.

WANTED, reliable person or firm, resident in Boston, to carry line of high class gold mounted combs on commission basis; only such who are well and favorably known and able to influence large sales need apply. Address with references, "J., 3743," care Jewelers' Circular-Weekly.

WATCHMAKER and jewelry repairer wanted; preferably one understanding French, German and English; congenial position in New York City. Address, "N. F. R., 3709," care Jewelers' Circular-Weekly.

WANTED, immediately, first class watchmaker, must have own tools; permanent position to right party; write stating age, experience, references and salary expected. Address, Kingsbacher Bros., 505 Market St., Pittsburg, Pa.

Business Opportunities.

FOR SALE, jewelry business in interior town, within 100 miles of Detroit; going business. Inquire of Noack & Gorenflo, Detroit, Mich.

WANTED, traveling man to sell my business, will pay \$50 when sale is closed; \$4,000 will buy \$4,500 business. Address A. B. Regnier, Marietta, O.

WANTED, a good paying retail jewelry business in New York City; willing to invest from \$5,000 to \$10,000. Anton J. Anderson, 170 Broadway, New York.

FOR SALE, the patent right to manufacture a roller jewel setter that will set a roller jewel in 30 seconds, or will sell the patent outright. S. W. Christine, Bangor, Pa.

A RING FACTORY, doing fine work, and well equipped; a close price will be considered for cash offer; write if interested. Address "N., 3290," care Jewelers' Circular-Weekly.

FOR SALE; an opportunity to buy an established business; county seat; no stock except optical goods and fixtures; best reasons for selling. Address "E., 3663," care Jewelers' Circular-Weekly.

FOR SALE, jewelry store in Central Illinois; stock and fixtures, \$3,000; bench work runs \$90 to \$100 per month; ill health reason for selling. Address "A., 3698," care Jewelers' Circular-Weekly.

STOCK OF GOODS, fixtures, tools, etc., established trade, old stand, large southern city; cash sale, \$6,000; reason for selling, want to get out of jewelry business. Chas. J. Schmitt, 523 Elm St., Cincinnati, O.

WANTED, a first class practical optician to purchase an interest in a well established jewelry business, with a view of adding an optical department; location A1, Hartford, Conn. Address "C. S.," Room 638, Connecticut Mutual Bldg., Hartford, Conn.

FOR SALE; an opportunity to get an old established jewelry store, on one of the best streets in Washington, D. C., salable and clean stock, with a good repairing trade. For further information address "Opportunity, 3668," care Jewelers' Circular-Weekly.

FOR SALE, prosperous, well established jewelry business in one of the most popular seashore cities in New Jersey; clean, fresh, up-to-date stock and fixtures; best patronage; splendid opportunity; no cash required if secured. H. H. Caswell, Asbury Park, N. J.

HIGHEST cash prices paid for watches, diamonds and jewelry; quick and liberal returns; all business confidential; bank references. E. Noel, 552 E. 46th Place, Chicago, Ill.

FOR SALE, paying jewelry and optical business in a town of 2,500, practically no competition, in center of coal and timber fields; stock invoice, \$3,000, can be reduced; everything fresh and clean; an established, increasing business of 10 years; bad health reason for selling; two cottage dwellings for rent or sale. Address Box 144, Montgomery, W. Va.

FOR SALE, to close the business, stock and fixtures of Pachtmann & Moe-lich's jewelry store, located 37 years, at 363 Canal St., New York; 70 years continuously on same street; purchaser will be allowed two weeks free rent for an auction.

FOR SALE; here is your chance of a lifetime, to walk right in a well established jewelry and optical business, in a live town; population 10,000; county seat; city has modern improvements; only one other small jewelry store; can draw from a large scope of country; stock and fixtures inventory \$7,000; can reduce stock to suit customer; will sell at a big reduction, as I wish to retire from business; watch inspector for the Norfolk & Southern Railway Co. C. H. Wallace, Washington, N. C.

DO YOU NEED MONEY? If so, send your diamonds and watches to me and get quick and liberal returns; highest cash prices paid for entire jewelry stocks; will send our representative if necessary; business confidential; National Bank references. H. Schwartz, 807 Chicago Savings Bank Building, Chicago, Ill.

DO YOU WISH TO RETIRE? Why not turn your entire store or surplus stock into cash? We pay the highest prices, also advance liberal cash amounts on stocks; communicate with us before consulting others; we act quick and strictly confidential. Brooklyn Purchasing Syndicate, 608 Broadway, Brooklyn, N. Y., Telephone, 2328 Williamsburg.

For Sale.

FOR SALE, jeweler's safe, inside dimensions, 24 x 27 x 30. Ford & Carpenter, 2 Maiden Lane, New York.

FOR SALE, two sets of second hand watchmaker's and jeweler's tools. Address "V., 3674," care Jewelers' Circular-Weekly.

FOR SALE, large fire and burglar proof safe, weight about 6,000 lbs., in good condition; reasonable. Cadmus, 41 Maiden Lane, New York.

OUR WELL KNOWN cigar cutter, which has been on the market for the past year; the patent has 16 more years to run; this cutter has been generally acknowledged as the best cutter on the market; it is a fine article for advertising purposes, and can be manufactured in large quantities; we offer the patent and the tools for sale, and a reasonable offer will be considered. Address, "C., 3712," care Jewelers' Circular-Weekly.

Wanted to Purchase.

WANTED for cash, jeweler's bench, flat rolling mills, foot blower, ring models; must be cheap and in perfect order. Address "P., 3726," care Jewelers' Circular-Weekly.

WANTED, jeweler's power rolling mill, one with good size rolls; must be in first class condition and reasonable in price. Address with particulars to Edward Todd & Co., 1 W. 34th St., New York.

(Special Notices continued on page 82.)

S. F. MYERS BLDG.
47-49 Maiden Lane, N. Y.

For Rent

A few choice, light and
very desirable offices

Moderate Rentals

Details of

J. A. MYERS

On Premises

NOTICE TO THE LIVE JEWELER WE HAVE THEM

Hampden, Springfield, Rockford, Hamilton, Elgin
and Waltham movements in all sizes and grades.
Railroad movements a specialty. Drop us a postal
and we will show you how to save big money.

THE EVESON CO. (Not Inc.)

503 Heyworth Bldg. CHICAGO, ILL.

EVERY REPAIRER

Should Have a Copy of

"The Jewelry Repairer's Handbook"

Issued by

THE JEWELERS' CIRCULAR PUBLISHING CO.
11 John St., New York Price 75 Cents

Practical Course in Adjusting

By THEO. GRIBI.

COMPRISING

A review of the laws governing the motion of the
balance and balance spring in watches and
chronometers, and application of the principles
deduced therefrom in the correction of vari-
ations of rate arising from want of isochronism,
change of position and variation of temper-
ature.

ELUCIDATED AND DEMONSTRATED

by original experimental researches in the actual
problem, never before published, showing the
causes that are operative in the variation of
rate, and leading to correct remedies. To
which have been added chapters on

Published Price, \$2.50.

SPECIAL REDUCED PRICE, \$1.50,
Post prepaid.

250 pages, including 18 diagram plates; Fine
Paper; Large Type; Clear Illustrations; System-
atically arranged; Solid Binding.

THE JEWELERS' CIRCULAR PUB. CO.
Publishers

11 John St., cor. Broadway, New York.

Special Notices.

(Continued from page 81.)

To Let.

TO LET, small light office; \$10 a month. Room
103, 1 Maiden Lane, New York.

PART of desirable office occupied by silversmiths.
Room 308, 320 Fifth Ave., cor. 32d St., New
York.

FOR RENT, one-half of, or desk room in light
office, Room 606, Jewelers' Bldg., 9 Maiden Lane,
New York.

TO LET, part of fine light diamond office, mod-
erate rent, for manufacturer's representative
Room 1308, 9-13 Maiden Lane, New York

TO LET, a desirable office, 170 Broadway, with
without partitions; liberal reduction in rent
Particulars, Room 1003, 527 Fifth Ave., New
York.

SMALL OFFICE, with large front window, on
bench room, suitable for watchmaker, diamond
setter, engraver or light repairing. Room 201
79 Nassau St., New York.

FOR RENT, small store or half of store, one side
on North Pearl St., between State and Columbia
Sts., Albany, N. Y.; moderate rent. Address
"T., 3664," care Jewelers' Circular-Weekly

REPRESENTATIVE of high class gold filled jew-
elry line would like representative of non con-
flicting line to share fight, desirable office. Ad-
dress "R., 3677," care Jewelers' Circular-Weekly

FOR RENT, repair shop in New York City for
jobbing jeweler; dynamo and complete fixture
already installed; excellent location and good
opportunity for practical man. "Repair, 3732"
care Jewelers' Circular-Weekly.



H. J. HOOPER

NEW YORK'S LEADING JEWELRY AUCTIONEER—Write him for
Testimonials that cannot be equaled by any Auctioneer in New York

37 MAIDEN LANE, NEW YORK CITY

The names that I publish below are merchants I have sold for direct; there are no wholesalers among them.
Anyone wanting the wholesalers I have sold for indirectly, I will furnish by mail.

Kohn Brothers, Missoula, Montana.
F. R. Stearns, 2 sales, Petaluma, Cal.
Ike Fields, Grass Valley, Cal.
George Johnson, San Bernardino, Cal.
R. F. Stearns, Stockton, Cal.
Thomas Howard, Marshfield, Oregon.
Franz Mahneke, Tacoma, Wash.
J. H. Shade, Brooklyn, N. Y.
John E. Knapp & Co., Salt Lake City, Utah.
James J. Tracy, Seattle, Wash.
Charles Hoff, Denver, Colo.
E. A. Walker, Pasadena, Cal.
R. Cohen, Pittsburg, Pa.
F. R. Williams, Buffalo, N. Y.
R. W. Wilson, Portland, Oregon.
Fred Woodman, Louisville, Ky.
M. Rundback & Co., Chicago, Ill.
Glendemann & Schweitzer, San Francisco, Cal.
Luke MacDonald, Visalia, Cal.
Bemas Brothers, Vallejo, Cal.
A. Tucker, Newport News, Va.
J. Luxenberg, Patton, Pa.
A. Lison, Kingston, Pa.
M. C. Khuner, Auburn, N. Y.
Everett Jewelry Co., 3 sales, Everett, Wash.
W. D. Meall, Marysville, Cal.
J. Joseph, Los Angeles, Cal.
A. Leibson, Duryea, Pa.
Davidow Brothers, 3 sales, Wilkesbarre, Pa.
Maiden Lane Jewelry Co., Elizabeth, N. J.
Dualibil Brothers, Schenectady, N. Y.
Fred. Ward, Visalia, Cal.
I. E. Gilbert & Sons, Modesto, Cal.
M. L. Stanton, Riverside, Cal.
A. E. Backs, Woodland, Cal.
M. S. Osgood, San Jose, Cal.
Chas. Wilcoxon, Napa, Cal.

George Jordan, Redlawn, Cal.
George Thomas, Auburn, Cal.
W. H. Wilson, Merced, Cal.
South Bend Jewelry Co., South Bend, Wash.
B. Banetti, Ferndale, Cal.
D. E. Gilbert, Modesto, Cal.
M. Barboska, Santa Cruz, Cal.
L. Robins, Utica, N. Y.
Yoshimi & Co., Atlantic City, N. J.
Cummings & Son, San Francisco, Cal.
J. M. Ives, Meriden, Conn.
E. H. Kutner, Albany, N. Y.
S. Susman, Stamford, Conn.
Rival Jewelry Company, Los Angeles, Cal.
A. H. Broom, Boise City, Idaho.
Levison Brothers, Oakland, Cal.
O. A. Dockhan, N. Tonawanda, N. Y.
A. Benjamin, Denver, Colo.
M. BasBarker, Fresno, Cal.
J. M. Dickson, Stockton, Cal.
I. M. Jacobsen, Ferndale, Cal.
J. Rupert, Terentum, Pa.
C. O. Biederman, Oneonta, N. Y.
Freeman Jewelry Co., Niagara Falls, N. Y.
Arritt & Co., Newport News, Va.
T. J. Routledge, Elmira, N. Y.
Rosenblatt & Co., Greenville, Tenn.
M. Marter, Cottage City, Mass.
J. F. Rockwell, Port Jervis, N. Y.
J. M. Frear, Binghamton, N. Y.
Palace Jewelry Co., Auburn, N. Y.
J. Luxenberg, Hartzdale, Pa.
H. Hedges, Fairmount, W. Va.
A. E. Morro, Los Angeles, Cal.
A. B. McKelvey, Pasadena, Cal.
Bogart & Page, Binghamton, N. Y.
A. F. Redfoot, Mt. Jewett, Pa.

L. Robins, Oswego, N. Y.
Blumberg Brothers, Syracuse, N. Y.
Sun Fat Company, San Francisco, Cal.
Peter Engel, Marysville, Cal.
S. Hollander, Salinas, Cal.
A. P. Hall, Visalia, Cal.
M. Edwards, Syracuse, N. Y.
C. Wilcoxon, Carnegie, Pa.
Keystone Jewelry Co., Pittsburg, Pa.
E. A. Walker, Pasadena, Cal.
S. E. Rich, San Jose, Cal.
Andrews & Wood, Modesto, Cal.
A. Thurman, Healdsburg, Cal.
J. Frost & Co., Chicago, Ill.
A. Clark, Spencer, Ind.
C. Hill, Southbridge, Mass.
U. S. Renshaw, Lansford, Pa.
L. M. Lasell, Martinez, Cal.
E. F. Brown, Pasadena, Cal.
J. Hyman, Sacramento, Cal.

Am now selling the stock of one of the leading jewelers of Lancaster, Pa., for the Jewelers' Board of Trade
of New York. Write me for full information.

DAN I. MURRAY

ESTABLISHED 1880

America's Recognized Leading Art and Jewelry Auctioneer!

ONE HUNDRED CENTS on the dollar guaranteed on any sale conducted by myself or any of my men. I have associated with me three of the best auctioneers in America. You can have the combined efforts of all three at the price of one. Turn your store over to me, I will turn it into cash and hand you the proceeds daily, which will include a satisfactory profit. Note a few of my latest sales, every one at a profit. Most of these fine stocks had been tried by the so-called leading auctioneers who were let out because they could not get anything near cost on diamonds and fine art goods. I took up the same sales three months later and not only sold goods for cost but at a profit. If I cannot give you better results than any of these so-called "leaders" I will make your sale for nothing.

Here are a few of my latest sales:

Oliver & Davis, 3 Maiden Lane, New York, six months' sale, daily cash receipts \$600 to \$2,000; Fred F. Mead Co., Syracuse, N. Y., three months' sale, daily cash receipts, \$400 to \$1,500; George Wolf Co., Louisville, Ky., three months' sale; Chas. L. Becker, Syracuse, N. Y., two and a half months' sale; The Edelhoff Bros. Co.'s stock, 574 Fifth Avenue, New York City, two months' sale; Dodd, Werner & Co., Cincinnati, four months' sale; Stevens, Wallace & Co., Chicago, two months' sale; Caldwell W. Johnson, 1027 Board Walk, Atlantic City, N. J., two and a half months' sale. Total sales for all these different firms, close to \$300,000; my books show a profit over cost to the dealer of 20 per cent. Remember, Brother Jeweler, these stocks were the finest in America, consisting of 14K. and 18K. solid gold, diamond jewelry, fine art, china, cut glass, etc.; not a brass watch sold by me. Now, if I can do this



DAN I. MURRAY



H. T. STAPLEFORD
One of my expert assistants, a man with
30 years' experience

for these merchants, why can't I do it for you? For over ten years my books have been open to all. I have kept the cost of all goods sold, and I have sold over one million dollars' worth of jewelry at an average profit of 25 per cent. over cost. I defy any auctioneer or pair of auctioneers to show a better or equal record; my charges are no more than the fellow with no ability. Why experiment and ruin your good name by allowing a lot of cheap goods sold?

If you want goods to help the sale along, I will furnish you, on memorandum bill, \$10,000 worth of diamonds, cut glass, watches and everything desired—goods direct from the manufacturers to you—at a price that will enable you to realize handsome profits. Your neighbor cannot compete, as he doesn't buy as I do for cold cash, \$10,000 at a time, if necessary, in order to get the lowest price.

At present selling the fine stock of J. H. Baber, Dayton, O. This sale was tried by a so-called leading auctioneer with his helper. They ran sale eight days and could not sell fine goods at all, in fact, had to close sale for want of people. My crowds are so large in same sale, the store will not hold one-half the people. My sales are fine goods only and at a profit over cost. You can consult me personally any morning at Hotel Emery, Cincinnati, O.

Write or wire me at once, at any of the following offices, for dates, as I now have many calls.

3 Maiden Lane, New York

151 Wabash Ave., Chicago, Ill.

512 Race St., Cincinnati, O.

DAN I. MURRAY, AMERICA'S RECOGNIZED LEADING JEWELRY AUCTIONEER
Recommended by the Press and the Trade.

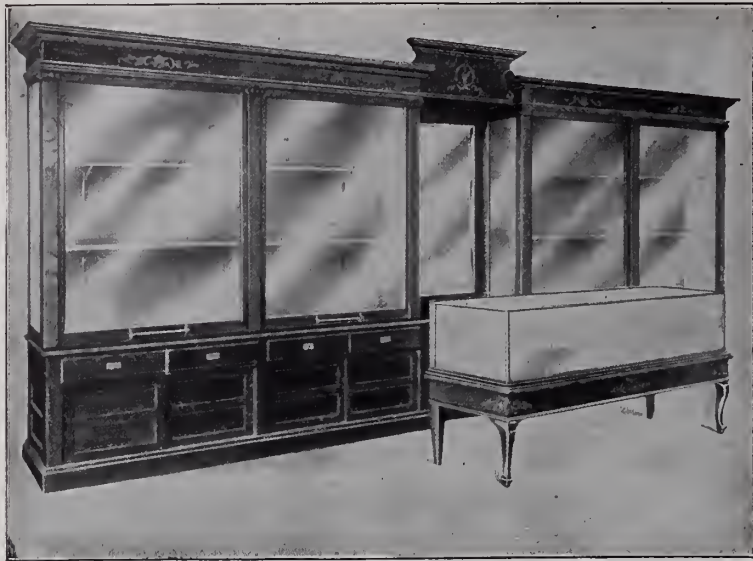

Colonial Wall Case, No. 123. Counter Case and Table, No. 107B.

F. C. JORGESON & CO.
 11 to 17 NORTH ANN STREET, CHICAGO
 MAKERS OF High-Grade Jewelers' Fixtures

Practical Course in Adjusting

By THEO. GRIBI

Comprising

A review of the laws governing the motion of the balance and balance spring in watches and chronometers, and application of the principles deduced therefrom in the correction of variations of rate arising from want of isochronism, change of position and variation of temperature.

Elucidated and Demonstrated

By original experimental researches in the actual problem, never before published, showing the causes that are operative in the variation of rate, and leading to correct remedies. To which have been added chapters on

How to make a Balance Arbor with Modern Appliances; How to Clean a Watch Properly; and, the Lever Escapement—Some Current Defects in it and How to Remedy Them.

Published Price, \$2.50.

**SPECIAL REDUCED
 PRICE, \$1.50,**

Post Prepaid.

250 pages, including 18 diagram plates; Fine Paper; Large Type; Clear Illustrations; Systematically arranged; Solid Binding. :: :: ::

**THE JEWELERS'
 CIRCULAR PUB. CO.**

Publishers

11 John St., cor. Broadway
 NEW YORK

A.W.C.CO

Supplying a Demand



14K.
 C-420

The best tribute paid to the line of moderate-priced cases that we are so vigorously exploiting is the widespread recognition already accorded them, indicating as it does a big and heretofore unsupplied demand for a really good and artistic gold case at a reasonably low price. For good looks and serviceability they recommend and sell themselves wherever displayed.

Sold by us directly to you

American Watch Case Co.

9-11-13 Maiden Lane

New York

JOHN AUSTIN & SON



Assayers, Refiners and Smelters

74 & 76 Clifford Street

PROVIDENCE, R. I.

We Do Our Own Smelting.

Frank Dederick.

Established 58 Years.

James E. Dederick

James H. Dederick's Sons, Assayers and Bullion Dealers.

All qualities of Gold and Silver, in Plate, Square and Round Wire, Rolled to any gauge. We are selling fine gold for \$1.04 per dwt. which we guarantee to be government assay bars. Small rolling for the trade.

ALL QUALITIES OF GOLD AND SILVER SOLDER.

16 Maiden Lane

NEW YORK.

We buy Old Gold and Silver.

Byrnes, Townsend & Swenarton Patent Lawyers

(Ex-Examiners U. S. Patent Office)
 277 Broadway New York
 Patents Trade-Marks

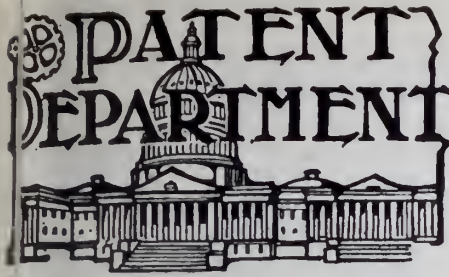

WHICH IS CONTAINED A LIST OF THE LATEST PATENTS GRANTED BY THE UNITED STATES AND GREAT BRITAIN, THE UNITED STATES PATENTS THAT HAVE PIRED AND THE REGISTERED TRADE-MARKS.

UNITED STATES PATENTS.

ISSUED MARCH 10, 1908.

81,215. FOUNTAIN-PEN. FERDINAND H. WURDEMANN, National Military Home, Tenn. Filed Nov. 19, 1907. Serial No. 402,857.

In a fountain-pen having a feed device on one side of the pen-nib, a stop to limit the movement

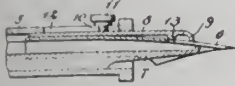

of the nib away from the feed device, and a projection on the stop engageable with the back of the nib.

81,349. AUTOMATIC TIME-VALVE. ARCH A. SHINGLETON, Cincinnati, O. Filed Feb. 19, 1906. Serial No. 301,893.

In an automatic time valve, the combination of a lock mechanism, a frame in which said clock mechanism is mounted, a crank shaft journaled in said frame, a valve adjacent to said frame, a crank on said crank shaft, operative connection between

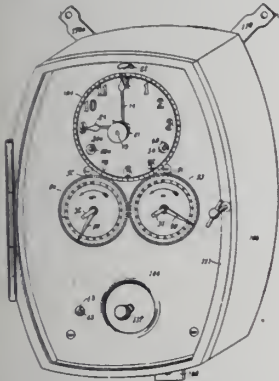

said valve and said crank, a face plate on said crank shaft, a projection on said face plate, a brake support pivoted adjacent to said face plate having a recess therein adapted to receive said projection on said face plate, a brake mounted upon said brake support, a sheave in operative connection with said crank shaft adapted to be engaged by said brake, and means whereby said brake is engaged with and disengaged from said sheave.

881,404. ELECTRIC ESCAPEMENT FOR TIME-MOVEMENTS. CHARLES F. HOLLIS-

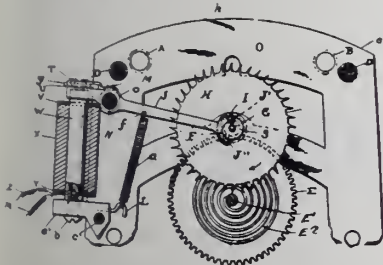

TER, Waterbury, Conn. Filed March 25, 1907. Serial No. 364,288.

An electrically operated escapement for clock

movements, comprising a shaft and means for operating the same, a hub mounted upon the shaft and bearing a pin disposed parallel with said shaft, a magnet, an armature operated by the magnet and bearing an arm having a pair of fingers disposed parallel with and upon two sides of the shaft, and a spring connected to the arm to retract the same when released by the magnet.

881,415. POCKET ATTACHMENT FOR WATCHES. FRANZ KRAWCZYK, Lodz, Russia. Filed Oct. 11, 1906. Serial No. 338,344.

A pocket attachment for holding a watch by the tension exerted by the wearer upon a garment, and comprising a cup-like body having an upper over-



hanging edge and a frontal side provided with an opening which permits the introduction of a watch, and secured within a garment pocket, said body having a slot in the upper overhanging edge thereof for the reception of a stem of a watch.

881,440. WATCH. WILSON E. PORTER, New Haven, Conn., assignor to the New Haven Clock Co., New Haven, Conn. Filed June 17, 1907. Serial No. 379,340.

In a watch, the combination with a center pinion having a longitudinal passage or bore throughout its length and having its rear end split for the production of spring fingers; of a removable center-



shaft adapted to be inserted into one end of said pinion the spring fingers of which grip the rear end of the said shaft and thus frictionally couple the said shaft and pinion; and a flat sheet-metal cannon pinion driven upon the projecting forward end of the said shaft.

881,555. REPEATING ALARM-CLOCK. WALTER D. DAVIES, New York, assignor to the Ansonia Clock Co., Ansonia, Conn. Filed Oct. 30, 1907. Serial No. 399,894.

In a clock movement provided with an alarm mechanism, the combination with the ordinary alarm trip spring, of an alarm repeating mechanism arranged to be thrown out of engagement with the

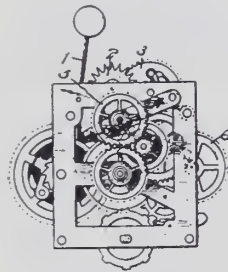

time mechanism when the said trip spring is in position to arrest the alarm the said alarm repeating mechanism including a rocking lever provided with an inclined laterally directed bearing in position to be engaged by the alarm trip spring.

881,583. JEWELRY-POLISHING DEVICE. CURTIS H. HODGKINS, Attleboro, Mass. Filed March 25, 1907. Serial No. 364,344.

In a machine for polishing jewelry, the combination with a tank adapted to contain a suitable cleansing solution, of a receptacle revolvably mounted in the tank having a plurality of peripheral sides, and a series of inwardly projecting ribs secured to each peripheral side of the receptacle, the ribs on some of the sides having a pitch

toward one end of the receptacle and those on the other sides having a pitch toward the other end of the receptacle, the ends of the ribs of the several sides abutting to form continuous zigzag channels extending circumferentially around the inside

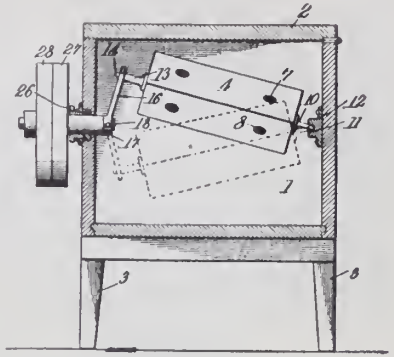

of the receptacle, screened openings being formed in the walls of the receptacle and communicating with the said channels and means for oscillating the latter about a longitudinal and a transverse axis.

881,622. CLUTCH FOR SCARF-PINS. ALBERT ROSENBAUM, New York. Filed July 25, 1907. Serial No. 385,428.

A clutch for scarf-pins consisting of a main-piece and a clamping piece pivoted thereto, the main-piece being provided with a socket open at

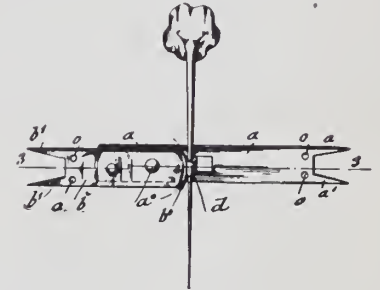

the side for receiving the shank of the scarf-pin and the clamping piece with an eccentric cam for tightly holding the shank in the socket, both main-piece and clamping-piece being provided with means for attaching said pieces to the scarf.

881,689. GEM-SETTING. RICHARD K. HOHMANN, San Diego, Cal. Filed April 20, 1907. Serial No. 369,366.

A setting for jewelry comprising a plurality of claws of fixed shape, a removable member having arms arranged to register with the claws and

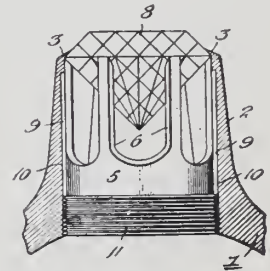

adapted to co-operate with the latter to hold a stone or gem, and means for preventing longitudinal and rotary movement of the member.

881,802. JEWEL-HOLDER. ALFRED T. HUNT,



New York. Filed Jan. 24, 1906. Serial No. 297,593.

A device of the character described, comprising a single integral piece of spring metal bent around

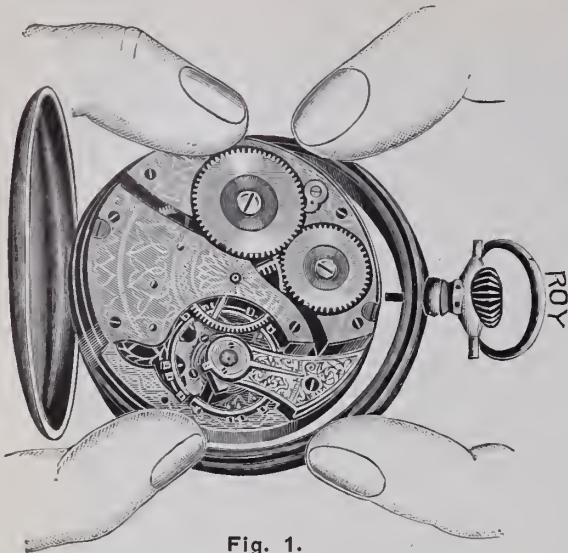

Fig. 1.

The Ægis Case Patented

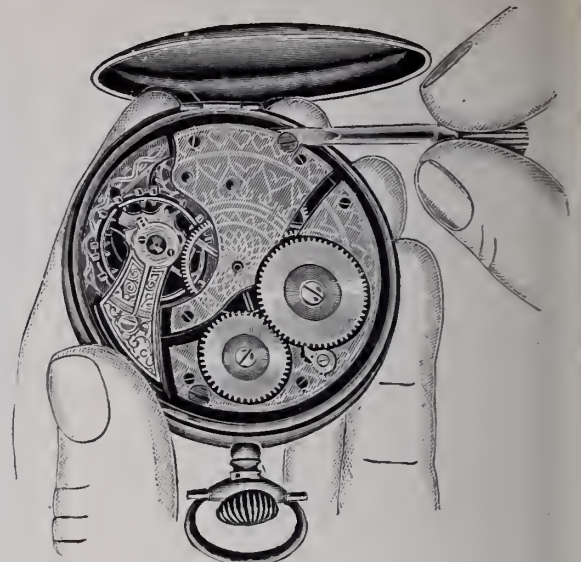

Fig. 3.

¶ The Ægis is a new creation in gold case making. The center and bezel are in one. Instead of having the ordinary Cap, this case is provided with a rigid metal movement Cup, held friction tight in position. This Cup gives protection to the movement such as cannot be secured with the conventional jointed cap, while dust is thoroughly excluded from the front by means of the one piece center and bezel.

¶ To fit movement, first properly adjust the hands; then pull out crown as usual, and insert movement from back of case, (see fig. 1). After winding square is properly fitted, the movement should be pressed down, so that it will be held in proper place by the spring in the case center. The movement cup should then be fitted.

¶ To take out movement, remove the movement cup (shown in fig. 2), by raising it near the pendant; pull out crown to release the square; lift out movement by means of case screw nearest joint (see fig. 3); withdraw movement from square and case.

Made only
by



Fig. 2

Made only
by

ROY WATCH CASE COMPANY

SAN FRANCISCO OFFICE
704 Market Street

21-23 Maiden Lane
NEW YORK

o that its ends are comparatively close together, and provided internally with a surface for engaging the finger, said ends being provided with gripping jaws provided with prolongations extending toward each other at their tips and having surfaces for engaging oppositely-disposed portions of a jewel.

REISSUE.

12,761. WORKMAN'S TIME-RECORDER. CHARLES T. HAWLEY, Gardner, Mass., assignor to the Simplex Time Recorder Co., Gardner, Mass. Filed Dec. 16, 1907. Serial No. 406,824. Original No. 853,878, dated May 14, 1907. Serial No. 322,662.

In a time-recorder, the combination with a time stamp, of a fixed card receiver or guide, an actuating device for causing the stamp to mark a card in the receiver, a movable stop to co-operate with



and vary the position of a card in the receiver to thereby vary the position of the card relatively to the stamp, said stop being positioned by operation of the actuating device, and periodically changing means to govern the relative position of the stamp and card receiver.

DESIGNS.

39,176. PLATE OR SIMILAR ARTICLE. CHARLES J. AHRENFELDT, New York. Filed

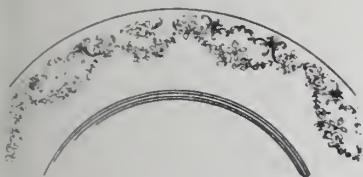

Jan. 30, 1908. Serial No. 413,477. Term of patent 7 years.

39,177. PLATE OR SIMILAR ARTICLE. CHARLES J. AHRENFELDT, New York. Filed



Jan. 30, 1908. Serial No. 413,478. Term of patent 7 years.

39,178. PLATE OR SIMILAR ARTICLE. CHARLES J. AHRENFELDT, New York. Filed



Jan. 30, 1908. Serial No. 413,479. Term of patent 7 years.

39,179. COVERED DISH OR SIMILAR ARTI-

CLE. CHARLES J. AHRENFELDT, New York.



Filed Jan. 30, 1908. Serial No. 413,480. Term of patent 7 years.

TRADE-MARKS REGISTERED MARCH 10, 1908.

68,180. CLOCKS. THE ASHCROFT MFG. Co., Bridgeport, Conn.

Filed Oct. 26, 1907. Serial No. 30,795. Published Jan. 7, 1908.

68,184. JEWELRY AND CERTAIN PRECIOUS-METAL WARE. CLARENCE LINZ Co., Dallas, Tex.

Filed Oct. 10, 1907. Serial No. 30,539. Published Jan. 7, 1908.

BRITISH PATENTS.

(ABRIDGMENTS OF SPECIFICATIONS, 1906, FROM The Illustrated Official Journal.)

ISSUE OF FEB. 26, 1908.

24,396. BRACELETS. E. G. HARROP, London. Nov. 1.

An expanding bracelet is built up of hollow links a, flat or curved, with narrow longitudinal slots b,

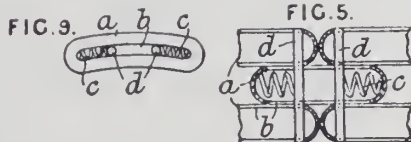

the outer series being connected in pairs by cross-bars d, passing through the slots of the inner series, and acted upon by helical springs c fitting the links. The screws are introduced through the slots b by screwing or twisting them in.

24,437. WORKMEN'S TIME-RECORDERS. E. S. HOWARD, London. Nov. 1.

The apparatus comprises hour and minute printing-wheels B¹, B, Fig. 2, carried in a pivoted frame D and driven by bevel-gearing from the clock through a flexible and extensible connection consisting of a steel rod or lazy-tongs E. Tickets are

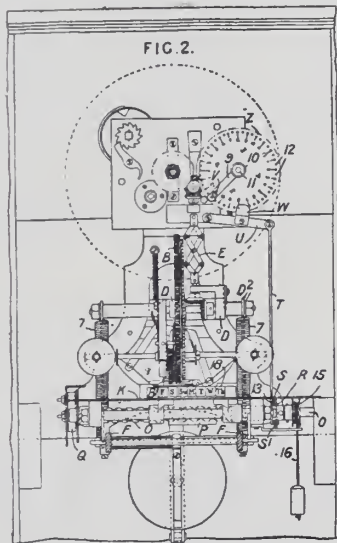

inserted by the workmen at a guide sheath K, and the amount of insertion is indicated by a scale N, a line s on the ticket 21, Fig. 5, being placed against the proper number on the scale. The "on" or "off" records are arranged on the ticket in vertical, and the days in horizontal lines. The frame D, carrying the printing-wheels, is lowered by the depression of a rod F¹, Fig. 1, connected

thereto by levers F, rods D², and springs 7, and the guide K is automatically moved laterally by a screw O engaging in a nut P formed on the underside of the guide. The screw is rotated by a spring or weight Q, and is controlled by a hit-and-miss escapement consisting of a disk R carrying pins S, S¹, the latter being placed nearer to the

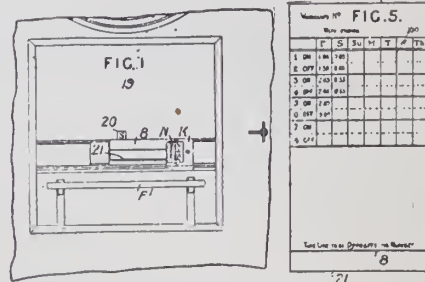

center of the disk. Engaging with the pins S, S¹ is a pin 13 on a rod T carried by a spring-retracted lever U, which is depressed when a protection V on an arm 9 strikes a block W on the lever. The arm 9 is adjustably secured by a nut 10 and a pin engaging in holes 12, to a disk Z revolving once in 24 hours, so that the lever V is depressed at any predetermined hour. When the arm T is lowered, the pin S escapes and the pin S¹ comes into engagement and is released as the arm rises, the pin S being again held by the pin 13. The card guide is returned to its original position by pulling a cord 16 passing over a pulley 15, and is provided with an index 18 showing the days of the week, the index being covered by a plate 19, Fig. 1, slotted at 20 to show the day that is being corded. The printing-wheels are arranged as described in Specification No. 23,454, A.D. 1898, except that the knife effecting the centering of the minute-wheel is placed beneath the wheel and mounted on the frame of the apparatus.

UNITED STATES PATENTS THAT HAVE EXPIRED.

[Reported especially for THE JEWELERS' CIRCULAR-WEEKLY by R. W. Bishop, Patent Attorney, Washington, D. C.]

Issued March 10, 1891.

447,782. BUTTON. ADOLF MANDEL, New York.

447,809. ENVELOPE MOISTENER AND OPENER. DANIEL COYLE, Philadelphia, Pa.

447,855. BUTTON. W. F. WHITING, Providence, R. I., assignor to Hiram and S. C. Howard, same place.

447,876. SUSPENDER-FASTENING. H. A. HAYDEN, Jersey City, N. J.

447,877. BELT. H. A. HAYDEN, Jersey City, N. J.

447,879. PENCIL-CASE. J. C. W. JEFFREYS and GEORGE DICKMAN, London, England, assignor to G. W. Mabie, Brooklyn, N. Y.

447,908. WATCH CASE PENDANT. BERNHART SCHIFF and LOUIS MAYER, New York.

447,924. SUSPENDER-BUCKLE. J. A. TRAUT, New Britain, Conn.

447,973. REPEATING-WATCH. BERNARD REBER, Locle, Switzerland.

448,027. INKSTAND. J. C. HACKER, Brooklyn, N. Y.

448,034. BOX. C. J. HAUCK, JR., Brooklyn, N. Y.

448,067. TOILET BRUSH. J. O. NIGHTINGALE, Paterson, N. J.

448,083. PENHOLDER. H. F. E. SCHUSTER, Savannah, Ga.

448,191. MAINSPRING. E. M. FASOLDT, Albany, N. Y.

Design issued March 12, 1901, for 7 years.

34,198. HANDLE FOR KNIVES. J. H. CROSBY, Jacksonville, Fla., assignor to the Greenleaf & Crosby Co., same place.

Design issued Sept. 6, 1904, for 3 1/2 years.

37,199. MIRROR-BACK. S. A. KELLER, New York.

Isadore Goodman, of the Northwestern Supply & Jewelry Co., Butte, Mont., has filed a petition in bankruptcy. The liabilities are \$20,000 and the assets \$14,100.

Waltham Watches

The history of the WALTHAM WATCH COMPANY is the history of watch manufacturing in America. More than half a century ago this Company introduced a new principle in the construction of watch movements, and has ever since applied the most advanced methods, producing always the best watches in the world. The WALTHAM WATCH COMPANY has built within its own walls the marvelous machinery employed in making the 15,000,000 Waltham watch movements now in use

Waltham Watch Company

WALTHAM, MASS.

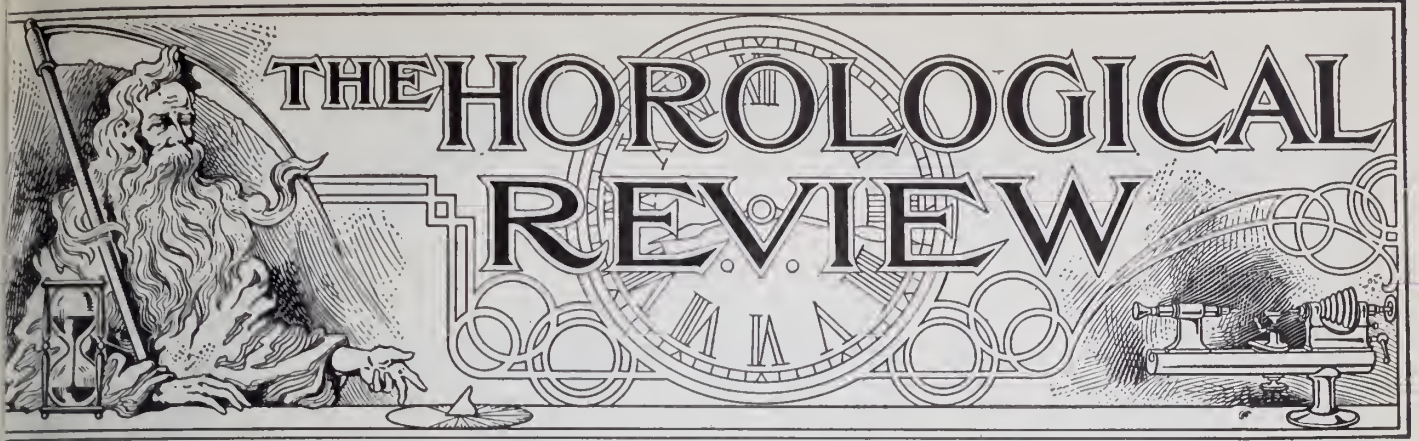

A CATECHISM OF THE LEVER ESCAPEMENT

Being an Informative and Instructive Series of Questions and Answers for Watchmakers and Apprentices.

(Written expressly for THE JEWELERS' CIRCULAR-WEEKLY by T. J. WILKINSON.)

(Continued from issue of March 4.)

QUESTION:—Explain the routine action of a double-roller escapement.

ANSWER:—By observing an escapement in action we note the following: When the roller jewel is about opposite the tip of the horn we find the guard pin without the

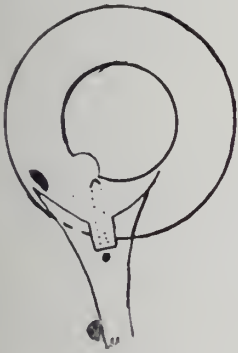

FIG. 23.

crescent (Fig. 23): the roller jewel next enters the notch of the lever and strikes it a blow which causes unlocking of tooth and pallet. The tooth of the escape wheel then enters on to the impulse face of the pallet jewel and through the energy imparted by the mainspring the opposite side of the lever notch strikes the roller jewel



FIG. 24.

a blow. This blow adds renewed rotating energy to the balance.

QUESTION:—What is the purpose of two tables in a double-roller escapement?

ANSWER:—The larger table carries the roller jewel; the smaller table is known as the safety table and is associated with the safety action.

QUESTION:—Has a double-roller escape-

ment any advantage over a single-roller escapement?

ANSWER:—Yes; a lessening of friction by a lessening of contact between the roller jewel and lever notch, and the use of low-angle pallets.

QUESTION:—In a double-roller escapement (to which all the following questions apply), when the guard finger is just outside the crescent, give the position of the roller jewel.

ANSWER:—The roller jewel will be opposite the tip of the horn. (Fig. 23.)

QUESTION:—When the guard finger enters the crescent, state the roller jewel's position.

ANSWER:—The center of the roller jewel will then be past the tip of the horn.

QUESTION:—Name the conditions under which unlocking should only take place.

ANSWER:—The roller jewel should be in the horn of the lever and the guard pin should be within the crescent.

QUESTION:—When the roller jewel is in the notch and the guard finger is in the center of the crescent, what is the relative position of tooth and pallet?

ANSWER:—The impulse face of the pallet will be found in contact with the impulse face of the escape wheel tooth.

QUESTION:—When drop or first lock takes place, where is the guard finger?

ANSWER:—It is still within the crescent.

QUESTION:—When does the guard finger make its exit?

ANSWER:—It makes its exit out of the crescent when the roller jewel is passing the end of the lever horn.

QUESTION:—When is the guard finger furthest from the edge of the safety roller?

ANSWER:—When draw or second lock is completed, *i.e.*, when the lever is at rest against its banking.

QUESTION:—When is the guard finger closest to the edge of the safety table?

ANSWER:—Immediately it makes its exit out of the crescent.

QUESTION:—When the roller jewel is opposite the end of the horn, what is the position of the guard finger?

ANSWER:—The guard finger is just within the crescent.

QUESTION:—When the roller jewel is well

within the notch of the lever, state position of guard finger.

ANSWER:—The guard finger will be found well within the crescent.

QUESTION:—When drop or first lock takes place, give positions of roller jewel and guard finger.

ANSWER:—The roller jewel will be about emerging from the notch of the lever (Fig. 24); the guard finger will be found within the crescent.

QUESTION:—When the roller jewel has



FIG. 25.

passed well beyond the tip of the horn, give position of the guard finger.

ANSWER:—It will be found outside the crescent.

QUESTION:—Briefly compare the action of the guard pin in single-roller escapements

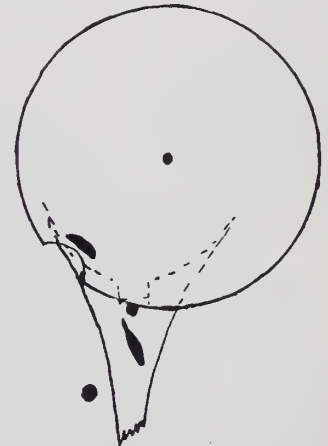

FIG. 26.

with the action of the guard finger in double-roller escapements.

ANSWER:—The action of the guard pin in single-roller escapements is as follows: It prevents overbanking; second, it prevents the roller jewel from striking the horns of the lever; third, it prevents trip-

How A Watch Business Was Tripled

The demand for the G. M. Wheeler grade Elgin, ever great, has been tripled by adding two sizes 12 and 16 thin models, thus making it a watch for the millions.

Perhaps you have also noticed that the

G. M. Wheeler Grade **ELGIN**

is being liberally advertised in all the great business-bringing publications. So you see it is just as plain as putting 2 and 2 together, that every progressive jeweler should carry this movement in all three sizes—18, 16, 12.

See jobbers' list for prices
or write the Company.

*Send for the Elgin art booklets,
"Timemakers and Timekeepers" and "The Watch."*

ELGIN NATIONAL WATCH COMPANY,

Factories, Elgin, Ill., U. S. A.
General Offices: 131 Wabash Ave., Chicago.
New York Office: 11 John St.



ing. In a double-roller escapement the guard finger's action is, first, to prevent verbanking; second, to a limited extent only, it prevents the roller jewel touching the lever horn, and to a limited extent it prevents tripping.

QUESTION:—What is meant by the term "tripping"?

ANSWER:—By tripping is meant the irregular action of an escape wheel tooth leaving the locking face of a pallet and entering unevenly, but slightly onto the pallet's impulse face. (See Fig. 25.)

QUESTION:—Give some of the causes for a tripping error in a single-roller escapement.

ANSWER:—It may result from an incorrect adjustment of the guard pin in relation to the roller table, or to ill-fitting holes for any of the escapement pivots, or it might be due to defective setting of the pallet stones.

QUESTION:—Give additional causes for a trip in double-roller escapements.

ANSWER:—The curve of the lever horn may be too great, or there may be an ill-set roller jewel, as we shall later explain.

QUESTION:—Explain why in a single-roller escapement, when we bring the guard

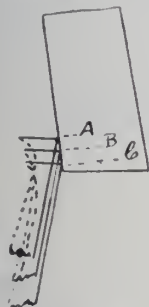

FIG. 27.

pin in contact with the edge of the roller table and the roller jewel is in position shown in Fig. 26, no contact with the horn and roller jewel takes place.

ANSWER:—The curve giving the lever horn of a single-roller escapement is always sufficiently great to clear the roller jewel when the guard pin is brought in contact with the roller table.

QUESTION:—Is a long horn necessary on the lever of single-roller escapements?

ANSWER:—No; only the shortest possible horn is required.

QUESTION:—In a single-roller escapement, when the guard pin just enters the crescent what part of the fork is opposite the roller jewel?

ANSWER:—The corner of the notch.

QUESTION:—In a double-roller escapement, is a long horn on the lever a necessity?

ANSWER:—Yes.

QUESTION:—What is the rule as to the length of the lever horn in a double-roller escapement?

ANSWER:—The horn of the lever must be of such a length that when the guard finger is barely outside the crescent, at least the tip or end of the horn shall be opposite the center of the roller jewel.

QUESTION:—In a double-roller escapement, just as the guard finger enters the crescent, what part of the fork is opposite the roller jewel?

ANSWER:—The upper part of the lever horn.

QUESTION:—When the guard finger is just within the crescent of a double-roller escapement, explain upon what parts the safety action devolves.

ANSWER:—Upon the roller jewel and curve of the horn.

QUESTION:—How do they act?

ANSWER:—The curve of the horn comes in contact with the roller jewel and thereby prevents tripping.

QUESTION:—If in a double-roller escapement, when the lever is against its bank, we find the guard finger has one-fourth of a degree of freedom from the edge of the safety roller, and the total lock of tooth and pallet lever against bank is two degrees, now, in the event of the guard finger coming in contact with the edge of the safety roller, figure out how many degrees of lock of tooth on pallet there remains.

ANSWER:— $2^\circ - \frac{1}{4}^\circ = 1\frac{3}{4}^\circ$ of lock remaining.

QUESTION:—Continuing the above question, we will allow one-half degree of freedom, lever against bank, between the curve of the horn and the path of the roller

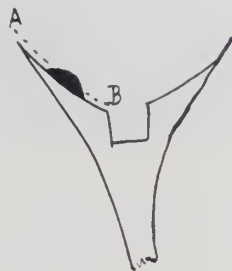

FIG. 28.

jewel. Now, in the event of the guard finger being within the crescent, estimate how much the pallet and tooth will remain locked when the curve of the horn touches the roller jewel.

ANSWER:— $2^\circ - \frac{1}{2}^\circ = 1\frac{1}{2}^\circ$; tooth and pallet remain locked to this extent.

QUESTION:—Suppose some one filed the curve of the lever horn so that, say, three degrees of space existed between the path of the roller jewel and curve of horn; state what would be the result when the curve of the horn is brought in contact with the roller jewel. (Fig. 28.)

ANSWER:—The effect on the tooth and pallet action would be disastrous, as the total lock of tooth on pallet being two degrees, and the freedom of the curve of the horn from the path of the roller jewel being three degrees, the result would be that when the curve of the horn came in contact with the roller jewel the tooth of the escape wheel would enter onto the pallet's impulse face, thereby causing a tripping error. (Fig. 25.)

QUESTION:—Make a drawing, illustrating the following conditions as they relate to the normal lock of a tooth on a pallet jewel: First, the position of tooth and pallet when the lever is at rest against its banking; second, the condition of the lock when the guard finger touches the edge of the safety roller; third, show the condition of pallet and tooth locking when the guard finger is within the crescent and the roller

jewel touches either the lever horn or the corner of the notch.

ANSWER:—In the drawing, Fig. 27, A represents the total lock of tooth and pallet when the lever rests against its bank, B represents the lock when the guard finger is brought in contact with the edge of the safety roller, and C shows the lock which remains when the roller jewel comes in contact with the horn of the lever, the guard finger being within the crescent.

QUESTION:—State the three positions in a double-roller escapement where it is possible for a tripping error to exist.

ANSWER:—We may find a trip in any of the following positions: First, when the guard finger is brought in contact with the edge of the safety roller; second, when the curve of the lever horn is brought in contact with the roller jewel (guard finger being within crescent); third, when the corner of the lever notch comes in contact with the roller jewel.

QUESTION:—State the two positions in a single-roller escapement where tripping errors can be detected.

ANSWER:—A trip in a single-roller escapement may exist as follows: First, when the guard pin is brought against the edge of the roller table, or, second, it may exist when the corner of the lever notch is brought in contact with the roller jewel.

(To be continued.)

The Clock in the Church at Lund (Sweden).

THIS clock resembled in some respects the famous timepiece at Lyons, France. It recorded the years, months, weeks, days and hours, the movable and fixed feasts of the church, the courses of the moon and stars, in their relation to the sun, etc.

When the clock struck the hour, armed knights appeared and exchanged as many thrusts of the lance as there were hours recorded. Then a door opened and the Holy Virgin was seen, bearing in her arms the infant Jesus. After she had seated herself upon a throne the three Wise Men of the East, with their attendants, surrounded her and, presenting their gifts, did homage to the mother of the Saviour. In the meantime two trumpeters sounded a fanfare.

Besides its importance as a work of art and a fine specimen of mechanical skill, the clock at Lund possessed no small intrinsic value, all the figures taking part in the automaton performance being of sterling silver. When in 1658 the Swedish province of Schoënen, in which the city of Lund is located, was annexed to Denmark, the conquering Danes, in accordance with the prevailing custom, "looted" the town. The famous clock, with all its accessories, was part of the plunder and was placed on board a ship for transportation to Denmark. The vessel encountered a severe storm en voyage and with its precious freight went to the bottom of the sea. The clock was never recovered.

T. Harris is about to begin the erection of a new jewelry store in Crookston, Minn.

Frank B. Cole & Son have sold out their jewelry business in O'Neill, Nebr., to Posewalk & Schurtz, Norfolk, Nebr.

Keystone Solid Gold Watch Cases



JEWEL SERIES



G-42019 B.



R-42345 B.



G-2 B



G-2 B.

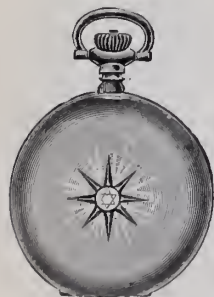

D-4 B



G-21231 B.

- ☐ Hunting and Open Face, Bascine, Plain Polish, Satin Finish and Roman, with French Bows.
- ☐ Open Face in special thin and compact model.
- ☐ Hunting Engraved in a large variety of patterns. Fancy Art Nouveau Bows on all fancy patterns. French Bows on all other designs.
- ☐ Open Face in Art Nouveau and High Class Decorative Effects, with exclusive fancy Art Nouveau Bows.
- ☐ Diamond Set Cases in a variety of patterns with French Bows and exclusive fancy Art Nouveau Bows.
- ☐ Hunting and Open Face Cases made only with inside caps, jointed backs and bezels, and in good substantial weights.
- ☐ Open Face Cases all have swivel pendants.
- ☐ These are all Cased by the MOVEMENT MAKERS—

WALTHAM WATCH COMPANY

with extreme care in order to assure perfect adjustment, and sold to you by your jobber only as complete watches.

KEYSTONE 14 K. SOLID GOLD CASES ASSAY

Trade-Mark



in back.

585-THOUSANDTHS FINE

(14 K. GOLD ASSAYS 583 $\frac{1}{8}$ -THOUSANDTHS FINE)

Note this guarantee



Look for



this tag.

THE KEYSTONE WATCH CASE CO.

PHILADELPHIA

NEW YORK

CHICAGO

CINCINNATI

SAN FRANCISCO

Karrusel Watch Constructed By a Watchmaker of Los Angeles, Cal.

ILLUSTRATED herewith is a "Karrusel" watch, which was designed and made by Geo. G. Koeberle, head watchmaker for J. G. Donovan & Co., Los Angeles, Cal.

The Karrusel watch, as most watchmakers know, is composed of two distinct games. One takes in all parts except the

of trouble is the one due to changes of position of the machine.

The balance, which is the time measurer, in the course of one revolution of the escapement frame has occupied the pendant up, pendant down, right and left and every intermediate vertical position; therefore the hands record the mean vertical rate, instead of the one rate of the vertical position in which the watch happened to be placed.

watches, one of which is a fine precision lever, the other a pocket chronometer. He believes in being a watchmaker in deed as well as in word, and is a strong advocate of a master workman being able to show something for his ability as such.

Mr. Koeberle is the publisher of the book entitled "Illustrated Studies in Horology," a description of which appeared in THE CIRCULAR-WEEKLY of Oct. 11, 1905.



FRONT VIEW OF KARRUSEL.



BACK VIEW OF KARRUSEL.

escapement, the other taking the escapement. The escapement frame is made to revolve in the main frame at a uniform rate of about once per hour. The error giving the watch adjuster the greatest amount

For a more detailed description of the Karrusel watch the reader is referred to the issue of THE CIRCULAR-WEEKLY of Sept. 4, 1907.

Mr. Koeberle has made two other

Proposals Invited for Electric Clocks for New Municipal Building in Washington, D. C.

WASHINGTON, D. C., Mar. 17.—Proposals are being invited by the District Commissioners until 2 p. m., March 30, for an electric clock system for the new Municipal building. Proposals will only be accepted from manufacturers of electric clock systems of established reputation or their duly authorized agents.

The system is to consist of one master clock, capable of driving 100 units, and 59 secondary clocks, seven clocks in the basement, 13 on the first floor, 10 on the second floor, 11 on the third floor, 10 on the fourth floor, seven on the fifth floor and one in the engine room.

The master clock is to be of the standing type, mounted in a solid oak case with plate glass doors, the secondary clocks for the first and fifth floors are to have 16-inch diameter dials, and on the other floors 14-inch, and all dials are to be of white enamel on pure copper, black Roman numerals, black hands and polished plate glass fronts, and all exposed metal work to be of bronze.

The master clock is to be self-winding, and the secondary clocks are to require neither winding nor setting.

The particular clock systems on which bids shall be submitted shall be at the option of the bidders, but they will be required to visit the building and ascertain conditions on which clocks are to be operated.

Emerson L. Tyrrell, Green Bay, Wis., died recently of paralysis, after an illness of one year. He was 63 years old, and had been in the jewelry business at Green Bay for the past 35 years. He is survived by a sister, Mrs. S. E. Allen, Springfield, Vt., and three brothers: John Tyrrell, Leavenworth, Kans.; Abner, Rutland, Vt., and Harlan, Fitchburg, Mass. Mr. Tyrrell was a member of the Masonic order, and the funeral was under the auspices of that society.

KARRUSEL WATCH

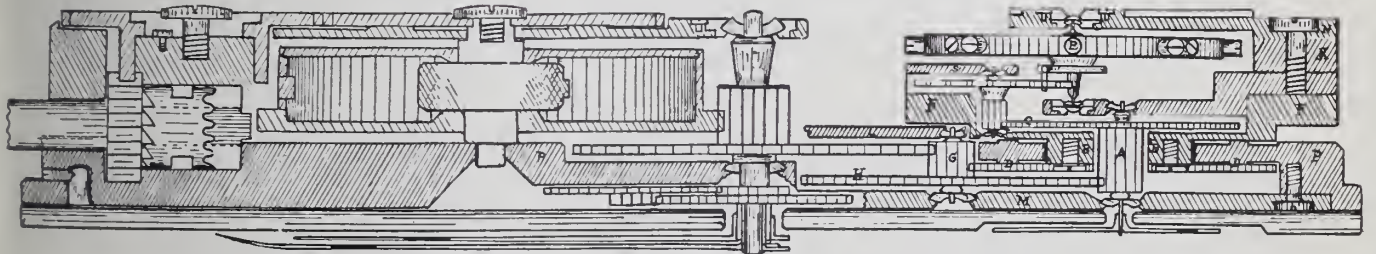
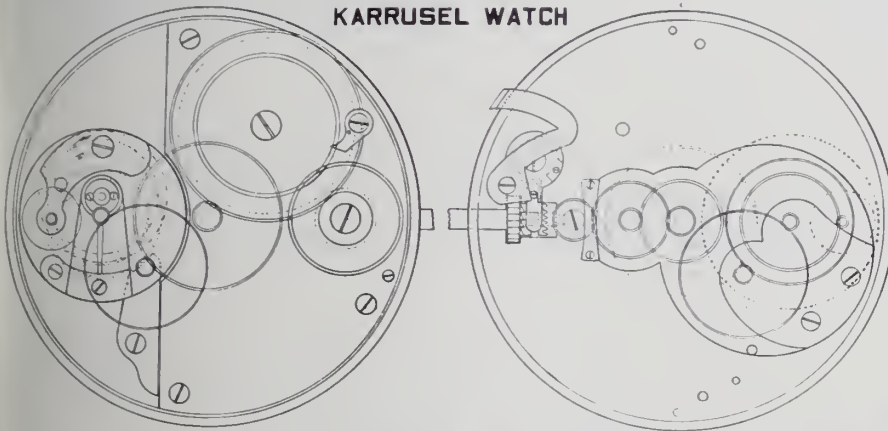

- P.P. Pillar plate.
- H.G. 3d Wheel and Pinion
- M. Bar under Dial.
- L. 3d Wheel top cock.
- D.D. Karrusel Wheel fixed to B.B. & driven by G.
- F.F. B.B. Bed plate of escapement frame.
- X. 4th Wheel top cock which also takes bottom of Balance Pivot.
- S. Escape cock.
- E. Balance
- N. Balance cock.

THE advertising of the Howard Watch in the leading periodicals is attracting the attention of the best class of people everywhere.

Hundreds of inquiries are being received at the factory as to who sell the Howard in their respective communities.

Representative retail jewelers are writing to their jobbers, or direct to the factory, concerning the HOWARD agency.

Dealers who have the Howard in stock are making sales by announcing that the watch may be seen at their stores—thus identifying themselves with the Howard campaign and reaping the benefit of its influence locally.

The Howard watch and the Howard business policy tend to elevate watch ideals—give class and character to the store and protect the retailer from unscrupulous competition.

Not every jeweler can be a "Howard Dealer."

E. HOWARD WATCH COMPANY
WALTHAM, MASSACHUSETTS



The Howard Watch

In the matter of time everyone defers to the man with the HOWARD.

It's a fine thing to know what o'clock it is and not doubt your own timepiece because others fail to agree with it.

One HOWARD will regulate an establishment. Let the HOWARD owner be ever so modest the watch soon gets a reputation for itself.

When you pay for a HOWARD you are not paying for complications but for simplicity—the finest materials ever put into a watch—strong and clean as a racer—perfect

adjustment, freedom from watch-troubles. The HOWARD is all *watch*—every pennyweight.

The finest timepiece ever made for a man to carry in his pocket. Favored by scientists, technical men, railroad officials, business men who are watch-wise.

Show cases and shop windows are full of watches, but you have to ask for a HOWARD. The output is limited; sale restricted to only the most reliable jewelers. The HOWARD dealer in every town is a good man to know.

The price of each HOWARD watch—from the 17-jeweled, 25-year filled cases at \$35, to the 23-jeweled, extra heavy gold cases at \$150—is fixed at the factory, and a printed ticket attached.

Find the right jeweler in your locality and ask him to show you a HOWARD.

Elbert Hubbard visited the home of the HOWARD Watch and wrote a book about it. If you'd like to read this little journey, drop us a postal card—Dept. J—we'll be glad to send it to you. Also a little catalogue and price-list, with illustrations actual size—of great value to the watch buyer.

E. HOWARD WATCH COMPANY
WALTHAM, MASSACHUSETTS

The above announcement appears in the leading magazines and periodicals for March. It reaches 7,500,000 subscribers (about 30,000,000 readers). It will be seen by every man in your community who can afford to buy a watch. Some of them will be interested. Are you a HOWARD dealer? Do the people of your locality know they can find the HOWARD at your store?

Ball Watches
THE RAILROAD STANDARD

Mr. Retailer!

Every Time You
Sell a "Ball" Watch.



1. You earn a fair return on your time and capital invested.
2. You secure a satisfied customer (the best advertisement of all).
3. A machine goes into service which will add to your reputation as a reliable "watch man."

Write to-day THE WEBB C. BALL WATCH CO.

Ball Building, CLEVELAND Railway Exchange, CHICAGO

WM. C. PENFOLD CO.

No. 35 MAIDEN LANE, NEW YORK

LARGEST EXCLUSIVE WATCH JOBBERS IN NEW YORK OF

Dueber-Hampden Watches
Dueber Cases — Hampden Movements

A Complete Line Always on Hand. Mail Us Your Orders

ESTABLISHED 1887

DUBOIS WATCH CASE CO.



Manufacturers of

Fine Solid Gold Watch Cases



Specialties in Casing of

CHRONOGRAPHS, REPEATERS AND ALL KINDS OF COMPLICATED WATCHES

NEW YORK OFFICE:
21-23 Maiden Lane

FACTORY AND MAIN OFFICE:
316 Herkimer St., Brooklyn, N. Y.

Practical Course in Adjusting

Published Price, \$2.50
Special Reduced Price, \$1.50, Postpaid

All Jobbers or
Jewelers' Circular Pub. Co.

? ?

HAVE YOU SEEN THEM ?

? ?

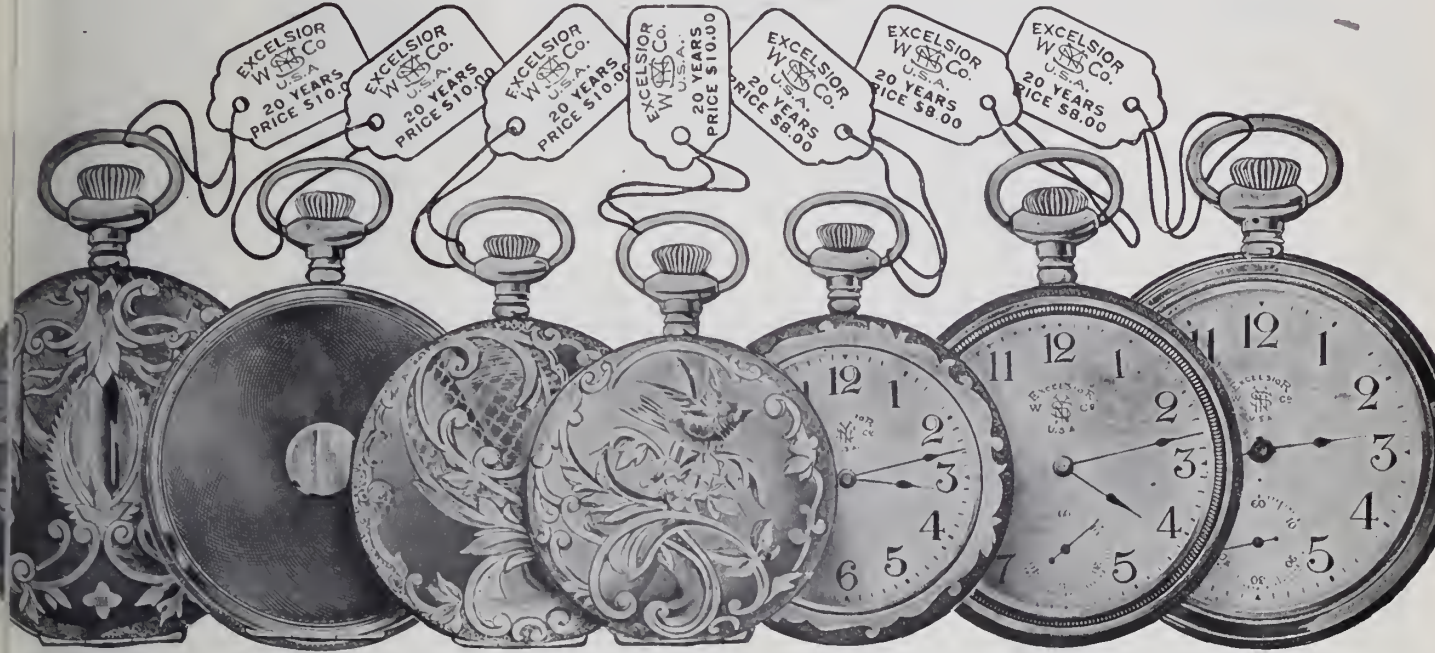

If not, ask your Jobber for the new line of

Excelsior Watches

Made Especially for the Jeweler

In 6, 12, 16 and 18 Size Open-Face and Hunting

Furnished as Complete Watches only in { 20-year Gold Filled
10-year Gold Filled
Silverode } Factory Tag Showing Price on Each Watch

GOOD PROFITS IN THEM FOR YOU

Three-quarter Plate, Nickel Damaskeened, Nicely Finished Throughout, Specially Timed, 7 Jewels, Quick Train with Bearings in Metal Settings, Cut Expansion Balance, Breguet Hairspring, White Enamel Dial. Every Watch is STEM WIND and PENDANT SET (excepting the 18 Size Hunting, which is LEVER SET)

All are THIN MODELS
All are "Timed in Case" at the factory
All sell at "Fixed" prices Everywhere

If you have mislaid your Trade Booklet, write for another copy NOW

NEW YORK STANDARD WATCH CO. JERSEY CITY, N. J.

For the Year of 1907

The Annual Timing Contest of the
GENEVA ASTRONOMICAL OBSERVATORY

awarded

53 out of 101 Prizes

TO

Patek, Philippe & Co. **WATCHES**

Namely:—The only First Prize for best Average Running among Makers. 4 First Prizes out of 5 (Including all the highest) for best individual running.

10 Second Prizes	out of 18
9 Third " "	" 17
12 Fourth " "	" 26
7 Honorable Mentions	" 18
10 Single Prizes	" 17

19 MANUFACTURERS PARTICIPATED.

Previous results at these contests

1906—49	out of 85	Prizes, incl. the First and Highest Prizes
1905—46	" 65	" " " " " "
1904—36	" 46	" " " " " "
1903 - 42	" 54	" " " " " "
1902—32	" 56	" " " " " "
1901—28	" 49	" " " " " "

Awarded Hors Concours (Beyond Competition)

Milan, 1906.	St. Louis, 1904.	Paris, 1900.	Paris, 1889.
	Antwerp, 1885.	Zurich, 1883.	

Gold Medal

Nuremburg, 1905.	London, 1885.	Calcutta, 1883.
Croningen, 1880.	Paris, 1878.	Vienna, 1873.
Paris, 1855.	London, 1851.	Paris, 1844.

Diploma of Honor: Nice, 1883.

NEW YORK
68 Nassau Street

GENEVA,
SWITZERLAND

HALL CLOCKS



**Elliott's
Celebrated
Tubular
Chimes**

**HARRIS &
HARRINGTON,**
12 BARCLAY ST.,
NEW YORK

Sole Agents to the Trade
for
J. J. ELLIOTT & CO.
LONDON.

**Importer and Manufacturer of
WATCH MATERIALS, TOOLS, JEWELERS'
SUPPLIES AND OPTICAL GOODS**



**Bargains
in
Staking
Tools**

Prices on
Application

Fine Gold, Silver and Platinum always on hand.
Highest Prices paid for Old Gold and Silver.

A. ZAREMBOWITZ
250 East Houston Street NEW YORK

New England Watch
Repairing for the Trade

GEO. W. HYDE & CO.
101 TREMONT STREET
BOSTON, MASSACHUSETTS

Make a Specialty of Repairing
New England Watches
Work returned in one week, and guaranteed
to be satisfactory in every respect. Recom-
mended by The New England Watch Co.

**WATCH REPAIRING
FOR THE TRADE**

Careful, Reliable, Prompt Work. Trade Refer-
ences. Price List on Request.

A. D. PAPAIZEN
71-73 Nassau St., Cockroft Bldg. NEW YORK

There isn't a better watch made anywhere, for the money, than the

New England

It is in no sense a "cheap" watch, but an accurate high-class timepiece—guaranteed to give satisfaction. The *New England* dealer is also assured a good profit on each watch sold. Send for price list.

The New England Watch Co.
WATERBURY, CONN.

Chicago

San Francisco



THE  OIL

**NEVER
GOES
WRONG**

The trade from ocean to ocean is praising this wonderful oil. IT POSITIVELY WILL NOT GUM.

Can you say as much for the oil you are using? Send 25c. to your jobber for a bottle, and end your oil troubles.

RANLETT & LOWELL CO.

SOLE MANUFACTURERS

Jewelers' Building BOSTON, MASS.

Wholesale Selling Agents

- M. SICKLES & SONS . . . Philadelphia
- SWARTCHILD & CO. Chicago
- NORDMAN BROTHERS CO., . . . San Francisco
- D. C. PERCIVAL & CO. Boston
- CHAS. MAY & SON Boston
- DANIEL PRATT'S SON Boston

53 Franklin Street, Boston
 SUSSFELD, LORSCH & CO., New York City
 H. S. MEISKEY CO. Lancaster, Pa.

Learn Watchmaking

Refined, profitable labor. Competent men always in demand. We teach it thoroughly in as many months as it formerly took years. Does away with tedious apprenticeship. Money earned while studying. Positions secured. Easy terms. Send for catalogue. Address

St. Louis Watchmaking School, St. Louis, Mo



The above TRADE MARK is well known to you, because it is on every watch and watch movement made by the LANGENDORF WATCH CO.

The more of our large line you carry in stock, the more profitable and satisfactory are

YOUR SALES

Perfect Interchangeability of parts renders repairing easy.

Do not accept substitutes, but insist upon getting the genuine L. W. Co. make. It's far the cheapest after all, as the quality is such you may

DEPEND UPON

If your jobber cannot supply you with

THE RIGHT KIND of GOODS

write to the Sole Agents for the United States,

AMERICAN-SWISS WATCH CO.

1 Maiden Lane, New York
 CUSHMAN BUILDING

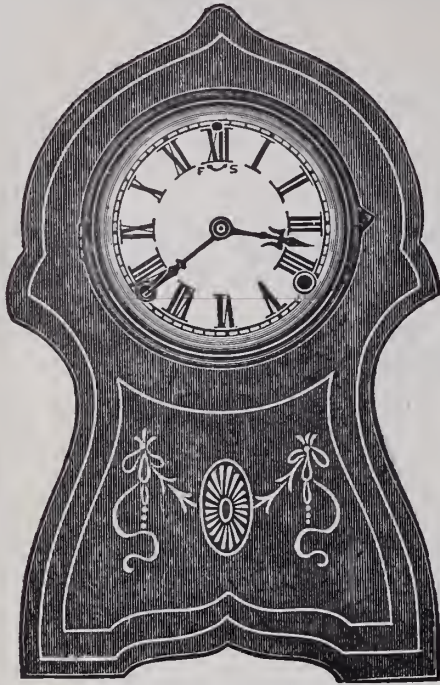

MANCHESTER
Height 13¾ in. Width 8¾ in.

SESSIONS CLOCKS

**Superior Finish
Popular Prices**

We have added a number of fine marqueterie cabinet clocks to our line which will interest you.

**The Sessions Clock
Company**

FORESTVILLE, CONN., U. S. A.
New York Salesroom, 37 Maiden Lane

Trade-Mark.



Trade-Mark.

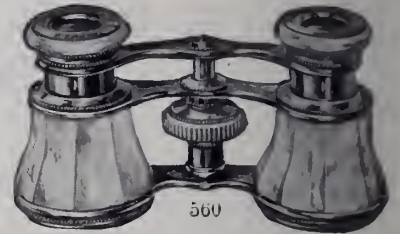

560

COLMONT OPERA and FIELD GLASSES

have been recognized by Opticians who really wanted a good article without paying too high a price.

With Colmont Glasses
You Have a Guarantee

The name STANDS for honesty and uniformity of construction, fairness of price.

For your own advantage, investigate the "COLMONT" line at your jobber's.

**SUSSFELD, LORSCH
& CO.**
Importers

NEW YORK

PARIS



THE progressive jeweler to-day knows that when a customer comes into his store he must be impressed with the idea that he is doing a high-class business.

In order to do this he must have the goods. No article you can buy will give your store more tone than a fine Hall Clock. It will also give you a fine profit. Purchase a "Waltham" and you will soon find a customer for it.

Send for catalogue, descriptive of many styles and kinds.

WALTHAM CLOCK COMPANY

Office and Salesrooms, Waltham, Mass.

JULES JÜRGENSEN
Watches and Chronometers

PARIS—"THE GRAND PRIX"—1900

SOLE

RUDOLPH & SNEDEKER
65 Nassau St., New York

AGENTS

PRACTICAL COURSE IN ADJUSTING.

ALL JOBBERS OR JEWELERS' CIRCULAR PUBLISHING CO.

Published Price, \$2.50.
Special Reduced Price, \$1.50, Postpaid.

Buy Watches With Our Patent Ball-Bearing Bow Already on the Market



No watch case should be without it.

BEWARE OF IMITATION

Should your jobber not sell cases with these bows, write us and we will give you a list of jobbers who do.
Patented July 25, 1905; May 21, 1907. Other patents applied for
Patented in foreign countries.

The Wachter Manufacturing Co.
HARTFORD, CONNECTICUT

Case Screw Washer **URICH PERFECT FITTING**
Case Screw Washer



Easily adjusted and holds the movement securely even when case shoulder is worn away.
Prices: Gross, \$1.50; Package, 4 doz. assorted, 50c; single doz., 15c.
For sale at all material houses or direct
S. URICH, P. O. Box 1942, New York City

The New Continental Watch Co.'s Movements.



0, 12 and 16 Size. 7 to 21 Jewels.
All Bridge Model and Pendant Set.

Fitting all American cases without any change, interchangeable pendant set, have steel scape wheels, exposed pallets, double roller, Arabic or Roman dials, with and without marginal figures. CONTINENTAL WATCH CO. on bridges, C. W. CO. on dials except otherwise ordered. Special name or nameless movements require four months' time for delivery. Packed in glass show box inside paper box. No expense has been spared to make these movements the best on the market for the money. Every movement absolutely guaranteed. A full line of finished material constantly on hand.

For Sale by all Jobbers.

JULES RACINE & CO., Exclusive Importers,

103 State St., Chicago.

37 MAIDEN LANE, NEW YORK.

HOROLOGICAL DEPARTMENT
BRADLEY POLYTECHNIC INSTITUTE
Formerly Parsons Horological Institute
PEORIA, ILLINOIS
LARGEST AND BEST WATCH SCHOOL IN AMERICA
We teach Watch Work, Jewelry, Engraving, Clock Work, Optics. Tuition reasonable. Board and rooms near school at moderate rates.
Send for Catalog of Information

AN EXAMPLE OF A GREAT ACHIEVEMENT IN THE MANUFACTURE OF IMPORTED WATCHES IS EVIDENCED IN

"Tavannes" Movements and "Cyma" Watches

WHY?

Because all features heretofore existing that have been an obstacle to the modern watchmaker have been eliminated—being brought about by the introduction of automatic machinery in the manufacture of these goods, and the concentration of our mammoth factory on a modern scale, enabling us to furnish "FINISHED MATERIAL" ready to use.

"TAVANNES" movements and "CYMA" watches give most satisfactory results when exposed to the extreme influence of TEMPERATURE, ELECTRICITY or MAGNETISM.



TAVANNES WATCH COMPANY

131 Wabash Avenue
Chicago

ADOLPHE SCHWOB, Sole Agent for the U. S.
2 and 4 MAIDEN LANE, NEW YORK

704 Market Street
San Francisco

STORE KEEPING DEPARTMENT

That this department shall prove mutually beneficial to our readers, it is desirable that the members of the trade generally communicate with THE JEWELERS' CIRCULAR-WEEKLY regarding any advantageous device or plan which they are utilizing in connection with their business.

Ingenious Methods Invented in Order to Protect Jewelry Stores Against Burglars.

A CONTEMPORARY, *Moniteur de la Bijouterie et de l'Horlogerie*, in Paris, recently instituted a competition in order to discover proper protective means against the constantly increasing number of burglaries in jewelry stores, etc. In this competition were very well represented the goldsmiths as well as the watchmakers. Nevertheless, an exhibition of the devices, as well as the distribution of prizes, was necessarily postponed until the middle of October, most of the judges being away for their vacations. Among the devices were some very good, with other certainly impracticable, ideas. Several of them are worthy of attention.

Only a few inches removed from the street are articles often worth millions, just separated from the passers-by by a pane of glass, often little more than a quarter of an inch thick, when not materially thinner. A skilful blow on the glass or a rapid cut with a diamond and removal of the piece, gave the thief room enough to seize his booty in his hand and make off with it. Here an ingenious invention was applied. By the production in Saint Gobain of a special pane of glass, efforts were made to prevent these raids, and experiments made by experts prove their success. An employe of the firm, in the presence of the judges, struck the window a blow with a wooden club with all his force, but without result. At a distance of 15 feet several shots were fired at the window from a revolver of heavy caliber, but it did not suffer the least injury. The blow glanced off, and the bullets were flattened. Even the president of the Parisian Retailers, Monsieur Dumont, delivered several powerful blows on the glass without causing the least damage to it. The same experiment was tried with a double-beveled chisel (a heavy iron bar), also with an ordnance revolver at very short range; in both instances the glass showed merely a crack which, on the blows being repeated, did not extend further, nor resulted in any fracture that would allow a piece to fall out or be removed.

Nevertheless, this pane of glass, with a thickness of more than three-quarters of an inch, according to the *Journal der Goldschmiedekunst*, displayed a transparency which other panes did not possess.

Another device is the "self-protector," which consists of an ingenious combination of electric wire conductors, provided with numerous contacts and with which arrangement it is impossible to touch a wall, a safe, a floor or anything else without setting off an alarm or even starting up all the lights and brilliantly illuminating the apartment.

The inventor, Monsieur Bloch, Paris, exhibited the apparatus, and the invention is patented. The "self-protector" makes all

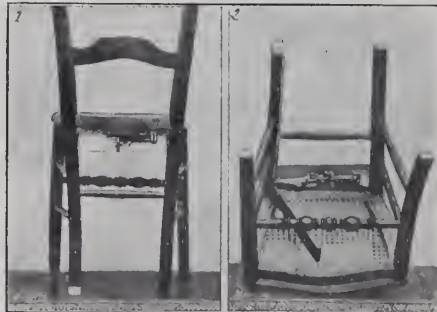

possible burglarious attempts fruitless, it prevents approach to a safe or the opening of a lock, it makes the breaking in of an armored door impossible, as also breaking in through a floor, wall or ceiling. Every unauthorized footstep in a protected place it announces, and no one can interrupt the alarm apparatus, no matter where or how it is installed. The alarm arrangement can be changed every day without dismantling the apparatus. The apparatus cannot be injured, and it is impossible to interrupt its operation without sounding an alarm. As soon as it or the conductor is touched it gives notice of the attempt to break in, etc., and even cutting the conductors will not stop the alarm. The inventor, M. Bloch, 22 Rue de Tocqueville, Paris, will gladly furnish further information.

A device made by a goldsmith and watchmaker, Anton Jacques, Grenoble, attracted general attention. He had a wooden box containing the safety contrivance, and placed four in an apartment, inviting one of the judges to approach a corner of the room or some other designated point. As soon as this was attempted a sonorous bell announced the at-

tempt. The simplicity of this device makes it especially valuable for all shops, and the inventor, in the general interest, does not seek to profit by his invention. This alarm device was tested in the presence of the "gendarmier" officials and the police commissioner, and was highly praised by them.

Following is a closer description of this device: No. 4 represents the position of a trap, extending from one wall to another or in a narrow place where a passage must be forced; No. 19 shows the position of the ring suspended from a small, headless nail within and beneath two hooked nails electrified to receive the ring in its fall at the instant of the passage of a burglar, the silken cord causes it to return to No. 18, its special hook. The silken cord used in these photographs was made very thick to facilitate description. No. 11 is the installation of a trap, stretched and branched to the existing installation of a call button. No. 12 shows the fall of the ring on the two hooks; in this case the alarm is given and the burglar revealed. In these two figures the electric wire is purposely shown, to facilitate photographic description, otherwise it can well be hidden behind the wall paper, or plinth, or elsewhere. These three figures show a simple installation that anyone can make, the installation of the call-button, the copper rings and nail, which can be bought anywhere (they were shown at the competition).

No. 2 shows a similar apparatus, but enclosed in a box. The apparatus is open, the two wires at the top are wrongly shown. The correct conductors of the current are inside and cannot be detached, because when the box is opened it sounds an alarm.

No. 1 is of the same character, but is made indestructible by cutting the wire. The ring, which is in this case at 90 per cent., falls on to a contact placed below it and sounds an alarm.

No. 3 is a trap constructed in the same manner as No. 1, but in place of ring and fuse a shot, by the introduction into a gun breech of an electric fuse (No. 23), which can readily be obtained at the grand bazaar Magenta, 86 Boulevard Magenta, Paris for the price of 1 fr. 50 cent. per box of 10. These fuses are very sensitive; they are employed in photography for igniting flash powder. If the charge is nothing but powder it makes only a noise, but if loaded with buckshot it means death.

No. 6 shows a firecracker, which may be obtained at the fireworks makers. To make it effective against burglars, where the neighbors are too far away to hear an alarm bell, a solitary store or a villa, for example

Storekeeping Department.

that is closed six months in the year, previous to placing the cracker connect it with the electricity. This is simple; remove the cotton fuse, enlarge the hole and introduce an electric fuse, as shown in No. 15. Glue firmly in place and set it, instead of the regular bell. But if it is a villa place, a large cracker, No. 14, sheltered from the rain, under a window; preferably conceal it, and within a radius of a kilometer inform the neighbors, so that they will know what it means when an explosion occurs. In this case branch the wire of your bell as far as the passage chosen and give the whole apparatus a coat of tar, to preserve it from the wet. To prevent a false alarm, install in some secret place a switch (No. 13), cut off the current when installing the device, turn it on at the last moment for a trial, and test it with a blank fuse. No. 22 shows the position of a trap raised and placed by day behind the door of a cupboard, or in some other place.

No. 9 is an annunciator to prevent burglary by means of the oxy-acetylene blow-pipe used by burglars to burn through a safe. It is composed of a strip of copper and steel, soldered together, and expands under the influence of heat and makes a contact at the bottom.

No. 10 is also an annunciator, but using mercury. Two copper rods enter a glass tube containing mercury, close the current and start an alarm. It is mounted on asbestos.

No. 8 is a simple band placed lengthwise along the inside of the lid of a strong box, like other annunciators. The heat burns it and a spring contact at the bottom sounds the alarm.

No. 7 is made the same, but it is a simple plate of metal which is unsoldered, and at the bottom the closing of the circuit rings an alarm.

No. 17 is a simple alarm clock, perfected, so that the pressure spring, which is placed under the bell, is reduced in such manner that the pressure on the stopping crank will be lessened, No. 21.

No. 20 shows the stopping crank, which has been subjected to a slight operation, consisting in polishing down the stopping point so that when causing the crank to move, it needs no resistance. The alarm clock thus altered is set to the hour to ring, the bell work only wound, a very fine silk thread attached to the bottom of the crank, the alarm hooked to a cane chair, over which a cloak is thrown to conceal it, and the other end of the silk thread fastened to another chair placed at a distance in such a manner as to stretch it. The burglar, in passing between the chairs, releases the clock and sounds an alarm.

No. 6 is a hollow bar of iron, very thick inside of which is a hard steel rod, and if the burglar saws it he cannot go very far before the teeth of the saw will be broken. No. 6 is a bar similarly made, inside of which is a wire encased in lead; the saw passing through it closes a circuit and rings an alarm.

The pictures of the chair, Nos. 1 and 2, show the trigger and the position of the detonator. The panel at the back is re-

moved to facilitate demonstration. One foot is hollowed to permit the passage of an iron wire which pulls the tumbler when the chair is displaced; another of the same pattern, but electric, performs the same service, but the accompanying photograph does not show it.

The wire used for traps is sold in France under the name of "fil flor à gants" extra fine.

In order the better to understand the working of the oxy-acetylene blow-pipe (No. 9), described above, the following details are given by Mr. Jacques:

tion of the box; you must carefully adjust, in the eyelet at the other end, a rod of silver, which should be allowed to protrude inward 0.02 to 0.03 millimeters; on the front of this silver rod attach a small square of silver, likewise to establish contact; fasten this on a non-conducting substance, porcelain, etc., so that it will have no contact with the box itself; attach to the bottom of this silver contact an electric wire; insulate it and carry it toward the hinges of the box; at the joint of the lid cause it to make an accordeon, turn it in a coil so that it can adapt itself to the opening and clos-

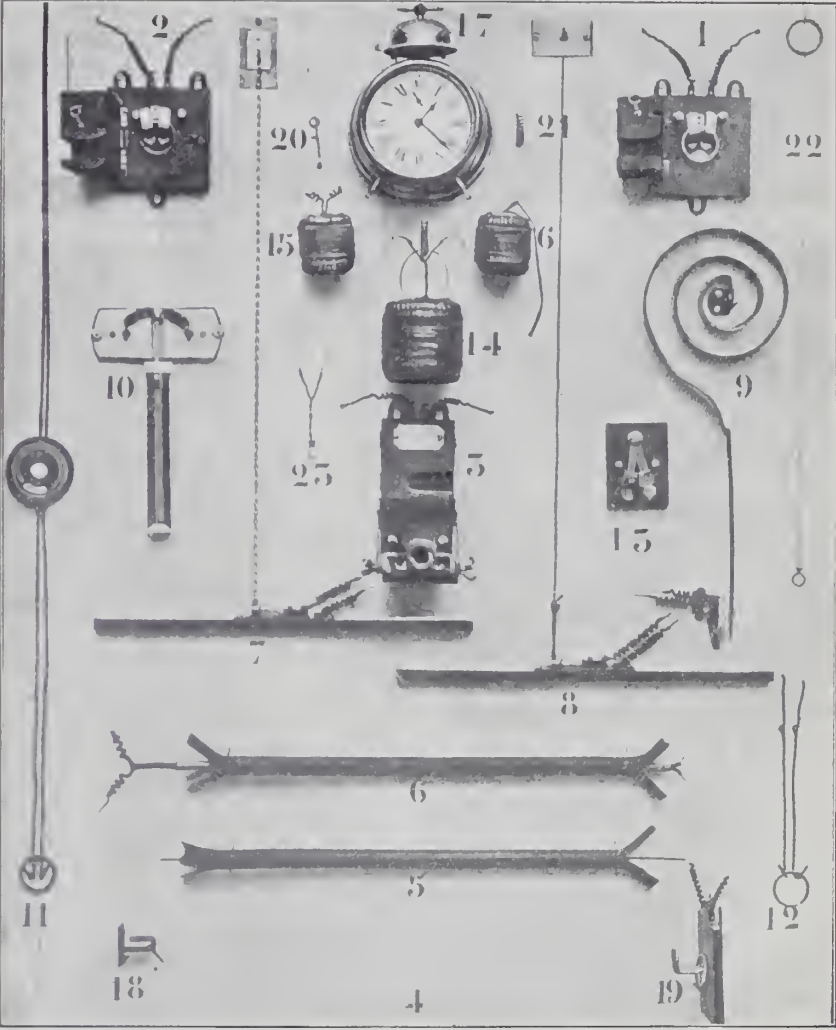

It is in accordance with this idea that I wish to submit, as a means of defense, an electric annunciator, capable of rendering good service against burglars who desire to imitate those who work with the blow-pipe. Here is the method of constructing and installing this annunciator: Take a plate of steel 0.01 meters thick and 0.50 meters long, and solder to it, for its entire length, a plate of copper of the same dimensions; roll it, by making four or five turns, into a spiral. Make a small round hole, an eyelet, at the two ends of the spiral; it can be drilled in the same manner as the spring of an ordinary clock. The center eyelet serves to rivet the spiral on to a little iron square, which must be fastened to the inside plate of the lid of the strong box. Install it in such a manner that the spiral is flattened against the inside par-

ing of the lid; make it pass through a hole out of the bottom of the box, at the edge of the hole, attach by a screw another wire, making contact with the box; conceal the wires carefully and connect them with the alarm bell in your apartment.

The installation thus made to the strong box or safe is really a call bell, operated by the action of heat. As a matter of fact, this is what happens when the burglar reaches the last inside plate. Under the influence of the heat created by his blow-pipe, the spiral expands, the piece of silver attached to its extremity comes in contact with the insulated square and gives the alarm; it is even possible to facilitate construction, to construct the whole on a movable pedestal placed close to the lid, inside the box.



The Making of Good Jewelry Advertising Copy.

(Written expressly for THE JEWELERS' CIRCULAR—WEEKLY by FRANK FARRINGTON.)

If every user of newspaper advertising space realized the possibilities of his "copy" and did his best to bring it up to the top of the possibility standard, the newspapers would be 50 per cent. better reading and they would pay 100 per cent. better dividends on the money paid for space in them.

The newspaper is the best advertising medium available for 99 jewelers in 100. The 100th man is the one who runs a local shop in a large place, where the great bulk of the paper's circulation goes to people outside of his territory.

In order to make newspaper advertising good it must first be given a regular space—the same space week after week. Then the copy must never repeat. It must be fresh with every issue. Who would read editorials or news that ran over one week after another? There must be no let up. Spasmodic advertising is simply a sinking fund for your profits.

Plenty of jewelers have "tried" advertising and found it didn't pay. Such men take a notion that they ought to advertise. They go to the paper and buy space. They run fairly good ads. in it for six months, or even for a year. They try to watch the returns. They keep a memorandum of the things advertised and make a record of sales that they think resulted from the ads. At the end of the time they find that the total sales do not figure up to enough to pay the advertising bill, let alone pay it out of the profits. Then they decide that advertising does not pay and they stop it.

The fact that all this time their business has increased and that they have been gaining new customers all the while is attributed to everything or to anything rather than to the advertising. The only criterion for the advertising in their minds is the direct response to the ad.

Of course, the older advertiser recognizes the foolishness of such a stand and knows that as long as the business is growing well the advertising is paying. Often, too, the advertising is paying when the business is no more than holding its own. This is especially true when competition gets busy and looms up stronger than ever. Then the advertising is necessary to keep the business already gained and to get new customers to take the place of those the other fellow lures away.

The average man who begins a newspaper advertising campaign has to write his own advertisements, and there is no reason why he should not do so. The man who writes his own copy gives it the individuality of himself and of his store. He knows,

too, better than anyone else can know, what he wants to talk about and what he wants to say about it. He ought to be better qualified to talk jewelry to the people than anyone else who never saw the inside of his store.

Naturally a man who is green at the business of writing will find it difficult at first to put his thoughts into what will seem to him to be readable language. Let him consider, though, that if the language is such as would sound well when talked over the counter to his customers it will do for them to read. There is a difference, though, between reading a talk on jewelry or other goods and in hearing it. It is the habit of writers who would make ad. writing seem easy to say that all that is necessary is to write it just as you would say it. That will do at first, but there should be a constant effort to write it so that it will give just the meaning you intend, and to do this it must make up in some way for the intonation of the voice and the expression of the face that go with the actual talk.

Write it at first just as you would say it, then read it over after it gets cold. Write the ads., if possible, a week or two ahead of time, and give them plenty of time to get out of your head so that you can read them as a stranger would. This will enable you to see many times faulty construction which would not appear to you at the time of writing.

It is well worth while for the man who wants to write good advertising to study the advertising of the high-grade men who have made a study of it for years. Read the introductions to the big department store ads. Study their arrangement. Subscribe for an ad. writers' journal and read it scrupulously. More than this, take pains in reading any good English to see how it is written. Never mind about trying to cultivate anything like a "style." Make your language correct and the style will take care of itself. It will be your own without any effort upon your part.

You take pains to get a good location for your store. Take just as much pride in getting a good location for your advertisement in the paper. Secure the most conspicuous space that you can get and buy the right to it for every issue. You will have to pay extra for special space, but it is well worth it. You want what you have to say to be just where no one can miss seeing it. You are paying for every reader of the paper, and all who do not read the ad. are a dead loss to you.

It will cost more, too, to have your ad. changed every issue than to let the same

old copy run the year around, but don't let that deter you. Suppose you want to advertise in a weekly in any average town or village. Perhaps it is not a very large place and the subscription is about 3,000 copies. You may want a five or six inch double column space. That will cost you perhaps considering special position and frequent change, nine cents per inch, or for the 10 or 12 inches about \$1 an issue. For the dollar you reach seven or eight thousand people. It is estimated that as many as five persons read every paper, on an average. This average is based on magazines probably, for it is obviously too high for a newspaper.

At all events, the cost of thus getting what you want to say before the public is not large. In no other way can you reach as many people for so little money.

In selecting a space, consider that if you are to use not more than four inches in depth it ought to be single column to look well. The space should measure more vertically than across. Double column, five inches or more in depth, makes the best sort of space, though eight inches single column will probably take as much copy as six inches double and cost much less.

The double-column space is better, however, as it gives your ad. a dignity that comes with size, and it gives it room to display itself in such a way as to attract attention. There is a money value to white space around the reading matter, thus setting you apart from your neighboring ads. giving you a greater isolation and insuring more readers.

Another way to make your advertisement stand out is to use for it a peculiar face of type—a type that will not be duplicated in any of the surrounding space. If you cannot arrange with your printer to give you an individual type, it will pay you to buy enough type of a peculiar face so that no one in the paper can duplicate it. Be peculiar, I do not mean odd in any way, simply different from the rest, though, of course, of the most distinct letter.

Your name in the advertisement ought always to look the same. It is best to secure this effect by having a name plate made in stereotype, using a facsimile of your signature or some individual type. A little study of the name plates in the ads. of the big stores will give you some idea. It is wise to have such a name plate made in various sizes, so that you can always use the same sort of signature to all the advertising you have printed, whatever size of space it occupies.

One of the beginner's (and often others') faults is to put too much in the space. It is not that they often try to advertise too many things. It is more the fault of verbosity. Too many words to say the thing they want to say. After writing your ad., go over it and eliminate all the words that have no value—all the unnecessary words. Get it down to the lowest common denominator; but don't spoil the sense by cutting it too much.

Don't be foolish in trying to get headings that will attract attention. Don't try to be funny. Let the jokes be put in the job column. Stick to your last. People may read jokes in an advertisement, but they will not buy the goods joked about.

Retail Advertising Department.

Let your headings be indicative of the goods talked about in the ad. itself. Make them as catchy as possible, but do not sacrifice sense to sensation. Scare heads may do for the news columns, but never for the ads.

For any kind of reasonable advertising there is nothing so good as the newspaper. It is issued frequently. It is read promptly. It is the cheapest way that you can reach the public, and you can reach them through that at shorter notice than in any other way.

Easter Advertising.

The Easter season is close at hand. It is expensive to get up any kind of a booklet or direct mailing. Postage rates are high and eat big holes in the profits. The newspaper space offers a means of telling more people about your Easter lines than any other plan can offer.

Begin to talk Easter right away. Let each issue of the paper describe some article that you sell that will appeal to Easter givers.

Head your ads.: "Easter Gift Talk No. 1," "A Rosary for a Gift," "Look at These — for Easter!" "Spread the Easter Spirit with a Gift," "Easter Gift Money Saved," "Some Inside Prices for Easter."

The more you talk about Easter, the more you imbue people with the idea that they ought to give at this season. The custom is growing and the jewelers can do much to help it grow. If times are a little hard this year in your town, make some price inducements that will look good to the people who want to send Easter gifts but haven't a lot of money to spare.

At any giving season the people always welcome suggestions of things to give. It is a universal cry, this "What shall I get?" lament of those who can think of nothing sufficiently novel, attractive and at the same time not too expensive. The newspaper ad. is the place to give suggestions. List the things suitable to give a man. Next week give a list of things suitable to give a young lady. Give a few words of description in each case and the price. Make the suggestions cover articles that the people would not be likely to think of for themselves. Let the list be really suggestive to the insufficient intellect of the gift buyers who never seem to know what they want.

The graduation season comes soon after Easter. It will be here before we realize it. It is up to the jeweler to make the most of all these occasions, and while the graduation gift is a modern development it has become a thing of general use. There are plenty of people, friends of those who are going to graduate this year, who do not know that those friends will be looking to them for a gift. They may even forget it in the case of intimate acquaintances.

Do not let it be laid at your door that you neglected to remind everyone within reach of your advertising that they ought to learn the names of everyone they know who is to graduate this June and make a list of those to whom they ought to send gifts.

Do a little educating along this line. Make it plain that the graduates themselves are universally expectant, that they are

looking for gifts from their friends, and that it will not do to disappoint them. This is easily insinuated into the minds of your readers, and along with that insinuation it is easy also to show that you have the kind of gifts best suited for graduation.

Write an ad. along this line: "A Young Man Graduates. Do you know him? Is he a friend of yours? Will he expect a graduation gift from you? Oughtn't you to remember him on this occasion? There is one thing that every young man wants and can use—a fountain pen. There is no limit to the price if you want to get something handsome. There is no need of paying a high price if you simply want it good," etc., etc.

All sorts of dainty jewelry is suited to the sweet girl graduate's desires. At the graduating age one is easily pleased. Everyone who knows a graduating girl wants to make her a present. You probably know that yourself. See that people know that commencement is coming and that at your store commencement gifts are stocked liberally and with a view to suiting the occasion with something appropriate.

Such an ad. as this might do: "When SHE Graduates, there is nothing too good for her. Of course, there must be graduation remembrances from all her friends. What will you give? Have you seen what we have for the Sweet Girl Graduate? Wouldn't a necklace be just about right? Our line of — necklaces this month is the best we ever showed. The prices will not scare you even if money is scarce. \$? will buy a pretty thing in the way of a — necklace. \$? will do better. Anyway, see these two values," etc., etc.

You know what you have in stock. It may not be necklaces, but go into some detail about what you have the most attractive line of and tell the people what you want them to know about it.

Of course, you must always have goods to back up your advertising or it will do you more harm in the end than good. The minute people begin to find that you have advertised more than you can show they will regard your advertisements with a just suspicion.

Along with the commencement season advertising comes the June wedding time, and this ought to bring some large sales to every jeweler. It doubtless does, and every jeweler realizes the value of getting all he can of this high-class trade.

The wedding business ought to have steady publicity from the middle of May until the last of June. In connection with advertising for this business one should emphasize the reliability of the goods. In making expensive wedding presents more than in almost any gift giving it is desirable that the gifts be substantial. The newly married couple are going to use their wedding presents a long time, and the givers will probably be where they can see them used, and it is desirable that the articles be just what they are represented.

In order to attract the wedding gift trade it is well to follow in the newspaper advertising an outlined campaign, going through your line of suitable goods, giving information about new things—things that are not of old style, like the proverbial castor. Emphasis should be placed upon

the fact that the goods are of recent pattern and the best make.

Then, too, it is most desirable to avoid duplicates by having a large variety, and possibly only one of a kind in high-priced goods. It is even possible to keep a record of sales for particular weddings and guarantee freedom from duplicates. Advertise as to the gifts purchased in your store that you guarantee no duplicates, and that goods will be exchanged if duplicated from elsewhere. This may entail a good deal of trouble and some goods may be brought back for exchange, but it will also entail a good many sales.

It stands to reason that if the wedding present buyers could be assured that by coming to your store for the presents they could lessen to a minimum the possibility of giving duplicates and could give with the gift your promise to exchange for something else if it were duplicated from other sources there would be an important added reason for patronizing your store.

Exploit all kinds of reasonable advertising in your newspaper space in good time for the talks there to exert an effect upon people's minds. Get after them before they begin to buy, and you will get a larger share of the purchases.

Put just as much of your personality into your newspaper space as you can do and do it well. You may know the advertising of the famous Tom Johnson, of Chicago. He writes all his advertising in the first person. It is never "we" nor "us," it is "I" and "me." He talks right straight from the shoulder, and he can do it in a way that impresses you with what he says as well as with the unique way in which he says it. It is not difficult to say things in a novel way. The difficulty lies in saying them in a novel way, and yet having them carry conviction.

Make your ads. read well and make them sound sincere. If you can develop an individual style that will make the copy selling copy as well as eye-catching copy, well and good. Don't on any account, though, become a freak and write advertising that is merely a curiosity.

People will not stand any foolishness when they are parting with their money. Be entertaining if possible, but at all events be sensible.

Jewelry valued at about \$75 was stolen about a week ago from a show case belonging to R. V. McDonald, Glens Falls, N. Y.

"Tony" Bauer, charged with burglary, was arraigned before Mayor Sawyer in Akron, O., recently, waived examination and was bound over to await the action of the Grand Jury under a bond of \$1,000. Bauer is charged with robbing the C. M. Hibbard jewelry store of about \$300 worth of jewelry. He was arrested in a room over a saloon in Barberton. No valuables were found on Bauer, but one Mike Biggie claims that Bauer tried to sell him a pair of opera glasses. Charles Veon, charged with grand larceny, has not been arraigned. He had in his possession a large part of the loot from the Hibbard store when arrested. Joe Strenick, who, it is alleged, was trying to sell some of the Hibbard jewelry around the city, is under arrest on a charge of receiving stolen property.

1 2 3 4 5 6 7 8 9 0 1 9 0 8 A B C D E F G H I J K

Alphabet and Figures

FOR CLASS RINGS, EMBLEMS, ETC.

HERPERS BROTHERS,

SETTING MANUFACTURERS,

Newark, N. J.,

1908

1908 A B C D E F G H ETC. 1908



LEIMAN'S PRESSURE BLOWERS

For Blowpipe Soldering, Melting, Sandblasting, Annealing, or wherever a blast of air is required at pressure

SIMPLE IN CONSTRUCTION **NOISELESS** IN OPERATION

NO Springs
Fiber Tips
Delicate Parts

HIGHEST PRESSURE AND VOLUME
LASTS A LIFETIME

LEIMAN'S NEW SAND BLAST

For Rapid Work in Large Quantities.
SEND FOR CATALOGS

LEIMAN BROS. Brill St., and Bonykamper Ave., Newark, N.J.
139-143 Centre Street, NEW YORK
Manufacturers of Jewelers', Silversmiths' and Metal Workers' Machinery,
Tools and WORK BENCHES—Plants Equipped.

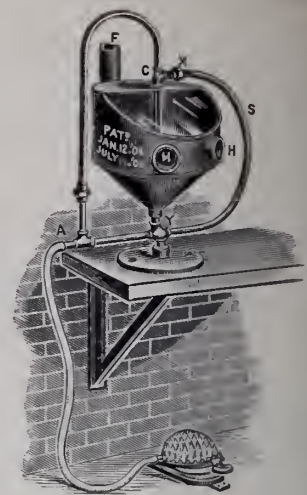

A Small Compound Sand Blast

Price, \$20.00 Foot Bellows, \$6.00

WORKS AS EFFECTIVELY WITH FOOT BELLOWS AS WITH POWER BLOWER :: :: ::

MADE of Galvanized Sheet Iron, 10 inches diameter, Glass Top, Fittings of Brass and Iron, practically indestructible. Satisfaction guaranteed. Ask your Jobber for it, or write to us. Other Specialties: Zeuner's Best Jewelers' Saws; American Swiss Files, equal to the best imported; Gas Furnaces, for Melting, Annealing, etc., etc.; Positive Pressure Blowers.

E. P. REICHHHELM & CO.
JEWELERS' TOOLS, FILES AND SUPPLIES
24 JOHN STREET, NEW YORK

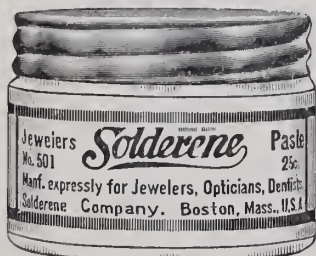

A PURE SOLDER IN PUTTY FORM

Apply to place to be soldered using iron or flame. Requires no acids, rosin, pastes or other fluxes. Absolutely neutral, preventing rust and corrosion. Saves time and waste. Large sizes for the manufacturing trade. If your jobber does not carry it in stock send us his name and 25 cents and we will send you No. 501 Jar, prepaid.

SOLDERENE COMPANY (Dept. 0)
91 Oliver Street, Boston, Mass., U. S. A.



L. LELONG & BRO.
Gold and Silver Refiners, Assayers and Sweep Smelters
S. W. Cor. Halsey and Marshall Sts., NEWARK, N. J.
Prompt attention given to Gold and Silver Bullion.
SMELTING FOR THE TRADE.



HERMAN KOHLBUSCH, Sr.,
ESTABLISHED 1859.
Manufacturer of Fine Balances and Weights
for every purpose where accuracy is required.
Office and Salesroom, 194 BROADWAY, NEW YORK.
Send for Price List. Tel. 370 Cortlandt.



CHARLES M. PRIOR, Designer

We have ready many new designs. Call or write. Etching is more popular than ever and we do it in the finest style.

'Phone 1639 Gramercy 24-26 East 21st St., NEW YORK

The Universal

Runs on edge of stone and sharpens the graver across the point, leaving no scratches running from the point back. The result is a bright, smooth cut.



Hight Mfg. Co.
Sole Manufacturers
Decatur, Ill.

For Sale by

- A. C. BECKEN CO., Chicago, Ill.
- SWARTCHILD & CO., Chicago, Ill.
- E. & J. SWIGART CO., Cincinnati, O.
- F. J. BOESSE & CO., New York.
- NORDMAN BROS. CO., San Francisco, Cal.
- LEONARD KROWER, New Orleans, La.
- H. S. MEISKEY CO., Lancaster, Pa.



WORKSHOP NOTES AND QUERIES

Answers are also solicited from our readers to the questions published on this page.]

QUESTION No. 2091.—Re-regulation of Clocks.—Is it true that every time a pendulum clock stops it requires re-regulation? I have been so informed by an expert repairer, but he could not give me the reason why. Can you? G. V. DeP.

ANSWER:—Such an assertion might hold good in the case of a fine watch or a marine chronometer; but the effect on a pendulum clock would be so infinitely small that it could hardly be determined.

QUESTION No. 2092.—Goat Hair Brushes.—In an article written by Theo. Gribi, mention is made of goat's hair brushes. I have looked through a great number of catalogues, but find none of these brushes listed. Also tell me what proportion do you use of cyanide of potassium. B. R.

ANSWER:—Goat hair brushes are not kept on sale by that name; but it is understood that the softest kind of brushes which are kept by material dealers are made of goat's hair. This does not scratch or deface the finest surfaces of the softer kinds of metal. The amount of cyanide for a cleansing solution in distilled water depends entirely on the circumstances, but half an ounce in a quart of water will make a good solution for dipping. Use before rinsing in distilled water.

QUESTION No. 2093.—Olive Green Dip.—Can you tell me if there is any formula for producing an olive green color on brooches, etc.? D. W. L.

ANSWER:—A writer in a recent issue of the *Brass World* gave a formula for securing this color on small metal goods, as follows: Double nickel salts, eight ounces; hyposulphite of soda, eight ounces; water, one gallon. The nickel salts are dissolved first, and the whole heated so that it stands about 150 degrees. The hyposulphite of soda is next added and the whole stirred. The articles to be colored, which may be of copper or brass, or copper or brass plated, are immersed in the solution until the right color is obtained. The use of a greater or less amount of soda will render the color darker or lighter. The immersion of the articles thus colored in boiling water for a few minutes will make the color more pronounced. If the article thus colored is lacquered, it will not fade, and is as permanent as any of this class of finishes. Small articles, such as buttons, buckles or similar goods may be treated in a tumbling barrel with the solution if desired, and this is now being done by some concerns who manufacture this line of work. Such a method is an advantage, as it removes the black specks which attach themselves to the surface. These specks may be easily washed off, but in the tumbling barrel they will not catch themselves to the surface.

A Method of Saving Gold from Rinse Water.

(From the *Brass World*.)

IT is well known that articles removed from gold-plating baths carry a considerable amount of solution on their surface. This is rinsed off with a corresponding amount of waste. In some establishments the wash water is saved and the gold precipitated from it, but this involves considerable labor and room, and, as the amount of gold may be small, it frequently is not considered worth the time and labor. The amount of gold which goes to waste in this

until after some time, and then water may be run in from the faucet D. The rinse water then flows through the pipe E to the special apparatus C. It will be seen that, even though a very small amount of water is allowed to flow from the faucet D, clean water is always present in the compartment B-4.

The water which runs from the compartment B-1 is that which contains the majority of the gold, but it will readily be seen that all of the water finally reaches this compartment and then flows into the apparatus C. This is a valuable feature, as those who have to pay for water by a meter find that to allow water to run constantly means considerable expense.

The various compartments shown in the compartment C are filled with zinc shavings, which, it is well known, have the property of precipitating gold from cyanide solutions. These may be allowed to remain for a long time and the gold finally recovered. The inventor states that, owing to the small amount of cyanide in the rinse water, the zinc frequently precipitates the gold in a manner that is difficult to recover, and to overcome this he hangs a basket filled with

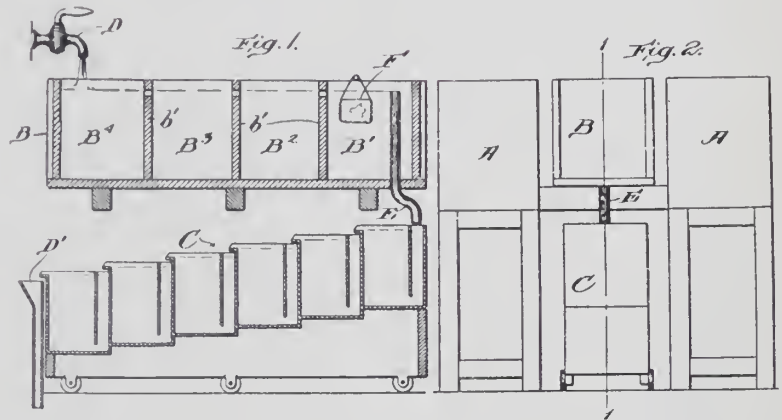

APPARATUS FOR SAVING GOLD FROM RINSE WATER.

manner, however, is considerable, and a suitable appliance for saving it would be valuable.

A method has been invented by William S. Hutchinson, of Boston, Mass. (U. S. Patent 838,717, Dec. 18, 1906), by means of which gold may be saved from the rinse water. In order to accomplish this, an apparatus herewith illustrated is necessary. The plating tanks are designated by A in Fig. 2. A rinse tank B is situated between them and the whole is raised so that a special apparatus C on wheels may be run underneath. This apparatus C is made movable so that it may easily be removed for cleaning out the gold.

The apparatus C is really the fundamental part of the apparatus. The rinse tank B is divided into compartments as shown in Fig. 1. By means of these compartments a much smaller amount of rinse water is used. For example, let us suppose that the compartments are all filled with water and none runs from the faucet D. The work is first rinsed in B-1, is then carried to B-2, next to B-3, and finally to B-4. In this manner the work may be thoroughly rinsed without even running the water. The last compartment, B-4, will not become contaminated

with cyanide (F-1) in the compartment B-1. This is hung in a perforated basket or porous cup so that it slowly dissolves. The water is thus enriched by cyanide so that the gold is precipitated in a manner that is easily recovered.

(The use of zinc shavings for precipitating gold from cyanide solutions is the method employed in the extraction of gold from ores by the cyanide process. This process consists of leaching the finely powdered ore with a weak cyanide solution. The gold and silver are thus dissolved. The solution is then siphoned off and the gold precipitated by allowing it to remain for some time in contact with the shavings.—Editor.)

An involuntary petition in bankruptcy was recently filed against Samuel Derefsky, a former jeweler of Niagara Falls, by Charles F. Danm, Buffalo, N. Y., who is a creditor for \$960. It was alleged that on Feb. 28, while insolvent, Mr. Derefsky committed an act of bankruptcy by confessing a judgment of Morris Rosenbloom & Co., Rochester. On this judgment the stock was about to be sold by the Sheriff, but the bankruptcy petition has held up the sale.

C. DORFLINGER & SONS

36 MURRAY STREET

NEW YORK



Hand-Made Blanks only.
Cut, engraved and etched
glass. Light, medium
and heavy stemware,
tumblers, etc.

LEATHER WATCH BRACELETS



Send for assortment on Display Card

ESTABLISHED
1850

C. F. RUMPP & SONS

TRADE MARK

Manufacturers of FANCY LEATHER WARE

PHILADELPHIA

New York Salesrooms, 683 and 685 Broadway

Mr. Jeweler:

Do you know that hundreds of your competitors in all parts of the country are making a specialty of Fans? Do you know that even a small line of Fans, properly displayed, will "dress up" the whole appearance of your stock? Of course, the Fans themselves must be suitable for jewelers, and must be bought from one who thoroughly understands the requirements of your trade. There is but one such house in America—

Louis Steiner

ESTABLISHED 1870

FANS
and Novelties for
the Jewelry Trade

520 & 522 Broadway
New York

PRACTICAL COURSE IN ADJUSTING

Published Price, \$2.50.

Special Reduced Price, \$1.50, Postpaid.

All Jobbers or Jewelers' Circular Publishing C



Owanda Cut Glass Co.

Manufacturers of

Rich Cut Glass

Originators of New Designs

HONESDALE, PENNSYLVANIA

A complete line of our high-grade goods shown at our
New York Office, 68 West Broadway.

Irving Cut Glass Co. Inc.

Manufacturers of

Artistic Cut Glass

HONESDALE, PA.

F. W. REICHENBACHER

New York Representative

No. 25 WEST BROADWAY, Room 43

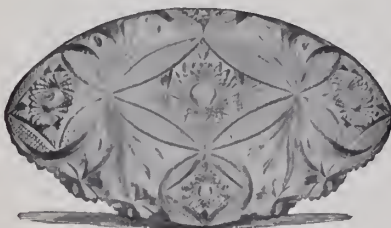

"Wild Rose," No. 122—14-inch
Ice Cream Tray

WM. BOLLES' SELF-FILLING NON-LEAKABLE FOUNTAIN PENS



SIMPLE—CLEAN—PRACTICAL

We make our own goods—and they have stood five years' test by the largest dealers in the country. Write for Catalogue and Price Lists.

THE WM. BOLLES CO., 1108 JEFFERSON ST., TOLEDO, OHIO

THE CONNOISSEUR

Devoted to Art Pottery, China, Marbles, Bronzes, Cut and Decorated Glass Ware, Bric-à-Brac, Lamps, Art Metal Wares, Fancy Goods and Kindred Lines.

Reproductions of Ancient Pottery of Crete in the Metropolitan Museum of Art, New York.

THE Metropolitan Museum of Art has in the course of the last year received from various sources casts and reproductions of objects found during the recent excavations in the Island of Crete. *The Bulletin of the Museum*, in speaking

In speaking of the original exhibits in the collection, the *Bulletin* says: "In addition to this collection of reproductions we are fortunate enough to be able to exhibit some original vases and vase-fragments, and a few bronzes, which were

Crete, excavators are allowed to export from the country only a very meager, second-rate supply of their finds. All of the better specimens remain in the Museum of Candia in Crete. Nevertheless, the present collection is of great interest. From the material placed at our disposal we have been able to reconstruct a number of entire vases, and the collection of fragments is representative of most of the different periods of Cretan civilization from the early Minoan II period (before 3000 B. C.) to



REPRODUCTIONS OF POTTERY FROM CRETE, INCLUDING VASE FROM VASILIKI, FILLER FROM GOURNIA AND JUG FROM GOURNIA.

of the excavations, says: "The result of these excavations has been to reveal a state of civilization which seems almost incredible at so remote a period. It certainly has come as a great surprise to the majority of archaeologists and historians that these people, of pre-classical Greece, who lived 3,000 or 4,000 years ago, should have been a powerful nation who extended their sway over the whole of the Eastern Mediterranean; should have lived in palaces almost modern in their appointments and comforts; should have had their arts and crafts highly developed; and have had in an advanced system of writing."

found in the American excavations of Harriet Boyd Hawes at Gournia, Crete, and presented to the Museum by the American Exploration Society of Philadelphia, through Mrs. Hawes. While the palaces of Knossos and Phaestos display the splendor of the Minoan civilization, the simple, provincial town of Gournia gives us a vivid picture of the everyday life of the period. It is interesting to think that though the material needs of this little town were certainly simpler, some of the most artistic products of Cretan craftsmen have been found there. Unfortunately, owing to the very strict laws in force in

the late Minoan III period (1450-1100 B. C.).

"Of the three vases here illustrated the one with the long spout is the oldest (Early Minoan II). This mottled ware has been found in great quantities at Vasiliki, near Gournia. The black tints, which effectively bring out the deep red color of the clay, are probably due to the action of fire. The elongated neck of the vase seems to be in imitation of a bird. The long, pointed drinking-horn or filler dates from the flourishing period of Gournia (Late Minoan I, 1800-1600 B. C.). Though in good preservation and of a characteristic shape, this

RAIL JUGS



**New
Rail
Jugs**

**Underglaze Enamel
Colors**

The latest production of the *Royal Doulton* factories. Exquisitely enameled in rich colors.

Sole Agent

W.S. Pitcairn

*44 Murray Street
New York*

Write for Booklet, "Quaint Bits of Royal Doulton"



Manufacturers' Distributor
35 MAIDEN LANE

"La Vigne"
NEWEST and Best-seller in
ROGERS SILVER-PLATE

Bright
or
French-Gray-Finish



TEN CENTS in postage will bring you sample teaspoon.

**JOSEPH IRONS, 35 Maiden Lane
NEW YORK, N. Y.**

PATENTS

obtained on inventions and designs. Trademarks, prints and labels registered.

R. W. BISHOP,
ATTORNEY-AT-LAW,
908 C Street N.W., Washington, D.C.

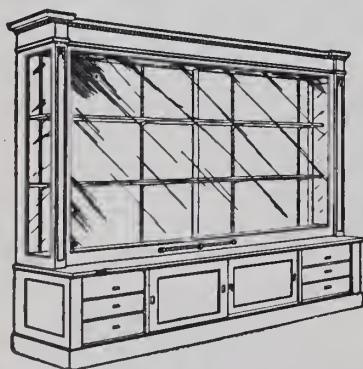

Jewelry Store Fixtures and Show Cases

OUR SPECIALTY

The enlargement of our factory in our new location enables us to quote low prices.

If you need fixtures or show cases let us hear from you. Estimates cheerfully furnished.

ALEXANDER H. REVELL & COMPANY, Rees, Dayton, Eastman and Hawthorne Sts., CHICAGO, ILL.



Established 40 Years

Every essential quality of piano construction, tone, touch, scale, design, and beauty of finish are combined in the BRIGGS. They are absolutely and unequivocally a standard piano of the world.

Any SUCCESSFUL JEWELER can largely increase his profits by the sale of pianos, and many receive the greatest part of his income from selling the

"BRIGGS"

We would like to talk this over with reliable concerns in unoccupied territory.

BRIGGS PIANO CO., Boston

se does not do justice to this highly artistic period, when delicacy and naturalness are the striking notes in decoration. These qualities are seen better in two or three other vases, which are, however, in somewhat fragmentary state. The third vase belongs to the period of decline (Late Roman III, 1450-1100 B. C.), when designs became stereotyped and conventional."

Old Glass and Pottery Sold in London.

At a recent sale in London of ancient glass and pottery, two ancient Greek glass drinking cups of cylindrical form with ornamental bands and widening toward the lip, seven inches high, the iridescence being rather poor, fetched £20 10s. Three smaller ones sold for £12. A small etched glass balsamary, spherical in body and short of neck, decorated with blue, green, purple and opaque white with streaks of gold, only 1 3/4 inches high and chipped, sold for no less than £22.

A tea service of 58 pieces in blue and white Chinese porcelain sold for 26 guineas, and another consisting of only 33 pieces of early blue and white Worcester sold for £9 10s. Three tiny cups and saucers in *famille verte* sold for £4 15s. An old powder-blue jar fetched £12 10s. A Swansea two-handled vase, six inches high, with gilt band and arabesque and wreath of flowers, sold for £4 16s., and a set of three ditto oviform vases went at £8 10s.

A set of seven Chinese vases and beakers of *peau d'orange*, very ugly and very modern, sold for £17 10s.; two Worcester services, both tea and coffee, sold for £3 and 9 10s. A Chelsea figure of "Britannia" and another group, "Father Time Clipping the Wings of Love," went at £6 and £6 5s.

A considerable amount of this kind of ware is in the salesrooms at present, and great caution should be exercised in purchasing. The same may be said of "Chelsea" and "Bow."

High Prices for Old Silver Sold at London.

A SMALL chalice with V-shaped bowl, dated 1567, sold at auction in London this month for 310 shillings per ounce. A small silver bowl, Charles I., dated 1640, maker's mark "W," fetched 290 shillings per ounce. A Charles I. plain paten fetched 190 shillings per ounce. A Charles II. porringer, dated 1679, with maker's mark (A. H.) and mullet and crescent, sold for 155 shillings per ounce. A beaker of the same period, dated 1682, sold for 290 shillings per ounce.

Two fine silver tankards of the same reign fetched, respectively, £140 and £133 13s., while one of the Queen Anne period sold for £130. A two-handled porringer of the same period by a charter silversmith, dated 1713, fetched 135 shillings per ounce; another of the same period sold at 72 shillings per ounce. A Queen Anne chocolate pot sold for 112 shillings per ounce. A William III. porringer, dated 1700, fetched 100 shillings per ounce. A sugar basin of this period sold for 82 shillings per ounce, and two pair of candlesticks of this period sold at 74 and 75 shillings per ounce, respectively.

A Louis XIV. casket, four inches by two

inches, made from mother o'-pearl pique with gold, sold at Christies for £141 13s.

A Notable Addition to the Bronzes of the Metropolitan Museum of Art.

AMONG the bronzes in the recent accessions to the collection of Greek and Roman art in the Metropolitan Museum of Art, New York, the statuette of the Diskos thrower deserves the first place, declares a writer in a recent issue of the Museum's *Bulletin*. The figure itself, excluding the modern base and the disks in the upraised left hand, measures a trifle over nine inches (23 cm.) in height; it is cast solid, and its present color is a very dark myrtle green, quite lustrous in the



BRONZE STATUETTE OF A DISKOS THROWER.

parts which have not been affected by corrosion. Its provenance has not yet been ascertained.

When acquired by the Museum, certain portions of the surface were coated with a crusty patina, which was removed by Alfred André, of Paris, with his usual skill, so that no details of the modeling are now obscured. The left foot and the greater part of the right arm are missing, but fortunately these are not essential in showing the movement of the figure.

The figure of the diskos thrower is splendidly shaped. The proportions are slender as seen from the front, owing to the relatively small size of the head and the length of the legs. The shoulders are massive; the neck, calves and arms are unusually large. Seen from or behind the thighs are slender but in profile they are of unusual size.

The manner in which the toes clutch the ground shows that the attitude of the figure is not one of repose but the beginning of a preparation for intense action.

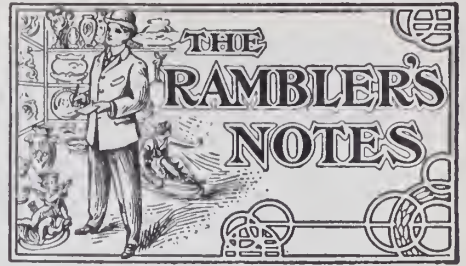

AN ARTISTIC CLOCK.

AT their salesrooms, 10 Barclay St., New York, Harris & Harrington have on exhibition an attractive clock set which is distinctly worthy of notice. The clock, which is round, is mounted on an oblong pedestal resting on a base of white marble. At one side of the clock and resting against it is a cupid holding outspread on the clock a parchment. In his other hand he holds a pair of compasses, with which he is about to plot a design. The base on which the clock and pedestal rest is embellished with raised work. On the face of the clock is a wreath of flowers in their natural colors.

DAINTY STYLES IN NEW FANS.

AMONG the many attractive offerings seen at the salesrooms of Lewy & Cohen, 530 Broadway, New York, are a line of sandalwood cabinet fans in hand-painted effects, representing beautifully dressed women and gallant men. Fans with bone sticks embellished with raised work gold and decorated with hand-painted tendencies are also shown, while more expensive fans with ivory sticks and fine lace make very acceptable offerings. One fan worthy of especial mention has pearl sticks overlaid with gold and is hand painted in colors. White lace fans suitable for graduation or wedding presents are included in the new line, and offer a wide selection to jewelers interested in these articles.

SPRING NOVELTIES IN RICH GLASS.

INCLUDED in the display of cut glass at the salesrooms of the International Silver Co., 9 Maiden Lane, New York, is an attractive punch bowl cut in star effect designs. The cups, which go with the bowl are cut in the same design. Another attractive offering is a cut glass lamp, cut in intricate pattern and embellished with sparkling bangles, suspended from the globe. Dainty bon-bon dishes, fruit baskets, trays and receivers are also included in the display. An attractive line of compotes, together with a variety of other offerings, are to be seen at the same salesrooms, as is also a novel chafing dish, having realistic looking bronze rabbits as a part of the decorative scheme.

THE RAMBLER.

C. E. True, formerly a watchmaker of Muskegon, Mich., is the author of a new book entitled "Uncle Carl," dealing with social and economical conditions in the United States.

A SHEAR

that will cut any kind of design to perfection. Better have a pair—they are mighty useful.

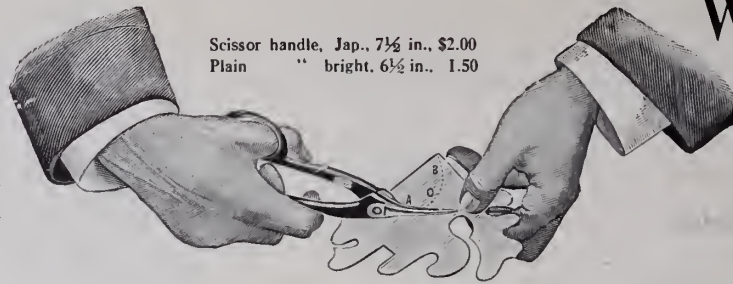

Scissor handle, Jap., 7½ in., \$2.00
Plain " bright, 6½ in., 1.50

William Dixon,

Incorporated

39 John St., New York

Formerly

F. W. GESSWEIN COMPANY



WE BUY

Old Gold and Silver Filings, Polishings, Sweeps, Hand Washings, etc. We will make accurate valuations and hold consignment subject to your acceptance. If valuation is not satisfactory, we reship to you at our expense.

WE PAY FOR OLD GOLD:

22 K. 88c. per dwt.	12 K. 48c. per dwt.
20 K. 80c. " "	10 K. 40c. " "
18 K. 72c. " "	8 K. 32c. " "
16 K. 64c. " "	6 K. 24c. " "
14 K. 56c. " "	4 K. 16c. " "

MARKET RATES FOR SILVER AND PLATINUM

Try us and you will Appreciate our Squareness, Promptness and Accuracy.

T. B. HAGSTOZ, Ltd., Main Office, 709 Sansom St., Philadelphia, Pa.
SMELTERS, ASSAYERS, REFINERS.

WE SELL

Gold, Silver and Platinum, various qualities, rolled flat or drawn to wire of any gage.

PRICES OF ALLOYED GOLD:

8 K. 42c. per dwt.	14 K. 66c. per dwt.
10 K. 50c. " "	16 K. 74c. " "
12 K. 58c. " "	18 K. 82c. " "

Gold and Silver Solder, either from formulas furnished, or our own. "T. B. H." Alloy, 25c. per oz. Guinea Gold, 75c. per lb. Shot Copper, 40c. per lb. We will send tables for alloying without charge. They save figuring.

'Phone 3759-R.

WM. F. RENZIEHAUSEN CO.

43-47 Oliver Street, NEWARK, N. J.

Gold and Silver Refiners

PROMPT RETURNS MADE FOR ANY MATERIAL CONTAINING PRECIOUS METALS
DEALERS IN GOLD AND SILVER, AND ROLLERS OF STERLING SILVER

Gold and Silver Anodes a Specialty

UNITED STATES SMELTING AND REFINING WORKS

L. & M. WOLLSTEIN

16 JOHN STREET, NEW YORK

SWEEP SMELTERS AND ASSAYERS

Dealers in Gold and Silver Assay Office Bars. HIGHEST and MOST PROMPT RETURNS made for Sweeps and all kinds of Waste containing precious Metals.

HIGHEST PRICES PAID FOR OLD GOLD AND SILVER

Manufacturers of STERLING SILVER.

Importers of PLATINUM.

Ore and Bullion Assays a Specialty.

ESTABLISHED 1886

GEO. M. BAKER

TELEPHONE UNION 1493-R

Gold and Silver Refiner and Sweep Smelter

Office, 91 Page St. } PROVIDENCE, R. I.
Works, 77-85 Page St. }

Our processes are strictly up to date and facilities most complete for doing all kinds of refining.
Specialties: Prompt and good returns.

CRUCIBLES.



Jewelers' Supplies, Etc.

Established 1850.

J. & H. BERGE,

95 John Street, NEW YORK.



PLATINUM AMERICAN PLATINUM WORKS

NEW YORK OFFICE
41 Cortlandt Street

NEWARK, N. J.

The Ackley Engraving Block

AND "JOKER" ATTACHMENT



Pat. March 20, 1906

Made by Engravers who saw the need of a Handy Time Saving Block

THE BEST IS THE CHEAPEST

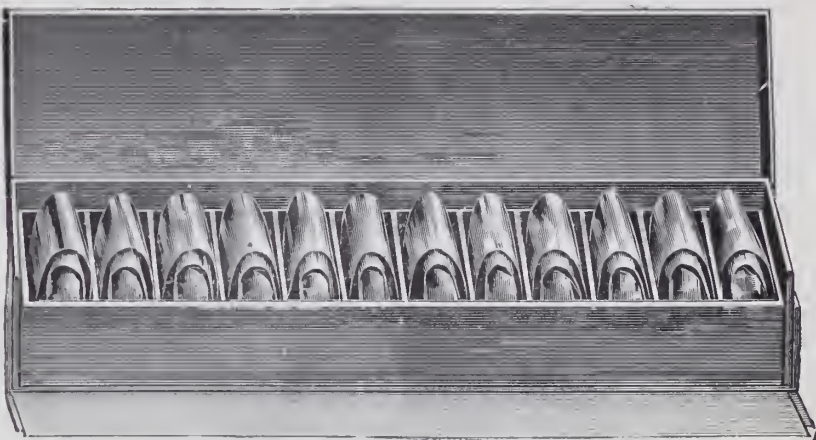

Why the "LAFAYETTE MAINSPRING" is superior

1st—It is guaranteed to be made of the Best Steel. 2d—It is made by Skilled Hand Labor. 3d—Each Spring is wrapped in Oil Paper and Silver Foil, which packing positively avoids exposure to the moisture of the air, and therefore all danger of rust is prevented. 4th—Each Spring bears a metal Tag, indicating the watch it is intended for, which accuracy is warranted. 5th—Each dozen is put up in a neat Box, having twelve partitions, one for each spring, so the handling of several springs at one time is avoided. 6th—The finish of the "Lafayette Spring" is, like its quality, superior to any in the market.

THE ACKLEY ENGRAVING BLOCK: Always ready to hold any article. No hunting for pins. The patent friction pins all remain in the head. Simply pull up to the desired height the ones needed. Each pin is numbered on top to designate size of groove or notch in it. They are so arranged in the head that they will readily hold all large or small articles either by three or more points of contact. The swivel jaw can be locked rigidly in an instant. The key will not fall off, yet it may be removed instantly. The patent base eliminates all unnecessary weight and gives the same movement as the old ball and socket base. This block is the result of years of practical experience of engravers who know the wants of engravers. There is nothing complicated about it to wear out or get out of order. Workmanship and materials are the best. Each part is copper plated before being heavily nickel plated, thus insuring a fine durable finish. Height, 6 3/8 inches. Diameter of head, 2 5/8 inches. Diameter of base, 6 inches. Weight, 8 pounds. **THE "JOKER" ATTACHMENT,** as shown beside the block, holds large and small signet and band rings, cuff buttons, collar buttons, signet pins, etc., firmly, without marring. It may be used on any block.

HENRY ZIMMERN & CO., Inc., 77 John Street
New York City

Exclusive Wholesale Distributors for U. S. and Canada



Enough metal is often lost in the careless reduction of

Filings, Waste, Scraps and Sweeps

to cover the cost of the work. We are careful and considerate enough to overcome this loss, thus enabling you to meet the expense out of a surplus that is ordinarily lost.

Try us and see if it isn't so

No. 236 Eddy St., **CONLEY & STRAIGHT,** Providence, R. I.

Gold and Silver Refiners, Assayers and Sweep Smelters, Dealers in Fine Gold, Silver and Platinum, all kinds of Gold and Silver Anodes.

ARTHUR MARSON

INC.

MAKERS OF

Swivels, Spring Rings, Snaps and Specialties in the Line, in GOLD and PLATINUM

Manufacturers of the

SMALLEST SPRING RING

on the market for Neck Chains

SEND FOR SAMPLES

23 MARSHALL ST., NEWARK, N.J.

WORKSHOP NOTES

For Jewelers and Watchmakers. Cloth. Postpaid. \$2. Published by The Jewelers' Circular Pub. Co. 11 John St., New York.

JANITSCHKE COMPANY, Inc.

33 UNION SQUARE, NEW YORK CITY

Manufacturers of Patented

DIES

for the Silver and Metal Trade

ARTISTIC CASTINGS OF EVERY DESCRIPTION FOR THE SILVER AND JEWELRY TRADE

Iron Hubs and Bronze Forces, False Core Work and Undercut Castings with Elastic Patterns. Fine Plaster Castings by the *Janitschke Patent* Superior to the Asbestos Process

TELEPHONE, 400 STUYVESANT

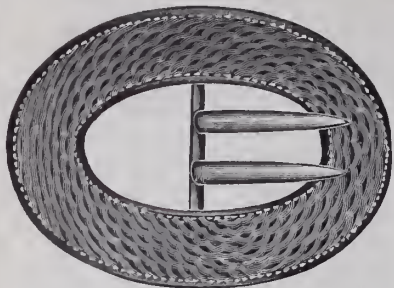

**Engine Turned
Buckles and Belt Pins**

4 Styles . \$9.00 a Doz.

*Silver, Gilt, Oxidized or
Gun Metal Finishes*

Quality Guaranteed

(Other Styles up to \$18.00 a Doz.)

Artistic, But Inexpensive
PRODUCTS OF
The "Apollo Studios"

WILL INCREASE YOUR
SPRING SALES

Bernard Rice's Sons

PROPRIETORS

544 BROADWAY

Works and Studios { 4-6 Marion St.
205-207 Lafayette St. **NEW YORK**



No. 471—ELECTROLIER
(Patent applied for)

Height, 20 in.—2 Lights
Copper Bound Leaded Glass
Shade, 17 in. Diam
PRICE, \$16.00



Fans

in endless variety
from the cheap-
est to the best, for wed-
dings, confirmation and
graduation.

SEND FOR SELECTION,
MENTIONING PRICE

Novelties for Easter

in Necklaces, Buckles,
Belt Pins, Brooches, Hat
Pins, Collars, in sterling
silver and gold plated,
set with semi-precious
and imitation stones:
lapis, coral, amethyst,
topaz, etc. Also an ex-
tensive line of Cameo
Jewelry.

LEWY & COHEN

IMPORTERS

530 Broadway Cor. Spring St.
NEW YORK



**LEMAIRE OPERA
GLASSES**

LEMAIRE FIELD GLASSES

Best in the World. Used in the Army and Navy.

SUSSFELD, LORSCH & CO., Importers

37 MAIDEN LANE, NEW YORK

MARQUE DE FABRIQUE



All Genuine Glasses
Bear This Mark
Large Variety in All
the Latest Styles

Established 1879

Manufacturer of

LOUIS W. HRABA Fine Leather Goods

29 East 19th St., New York

Exclusively for the Jewelry Trade

JACOT MUSIC BOX CO.

**MIRA MUSIC BOXES
AND MIRAPHONES**

39 UNION SQUARE - NEW YORK

THE

JEWELERS' CIRCULAR

WITH WHICH ARE CONSOLIDATED

THE HOROLOGICAL REVIEW,

THE JEWELERS' WEEKLY,

THE JEWELERS REVIEW

Copyright 1908 by
The Jewelers' Circular
Publishing Company.

11 John St., Corner Broadway, New York.

Entered as second-class matter at the New York, N. Y., Post Office.

40th Year

WEDNESDAY, MARCH 25, 1908.

Vol. LVI., No. 8.



Silver Wreath from Swedish-Americans to be Placed on the Bier of the Late King Oscar, of Sweden.
(See Text on Page 44.)

ALVIN SILVER

The New Alvin Plate surpasses anything ever made in Plated Silver Ware.

MADE IN ONE QUALITY ONLY—THE BEST. Must be seen to be appreciated. Send for samples.

Price list will be sent to all Jewelers in the next few days. Please notify us if you do not receive it.

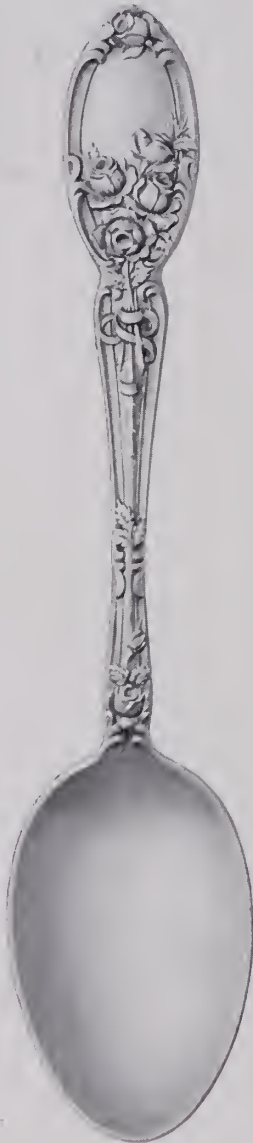

BRIDE'S BOUQUET.



LILY.



ALVIN MFG. CO

SILVERSMITHS

NEW YORK



Fahys Permanent Cases

To produce a gold-filled case with the appearance of a solid-gold case, and one that would wear permanently, we realized that it was necessary to use a high quality and a liberal amount of gold. This is why our Permanent Case has the finish and appearance of a solid-gold case.

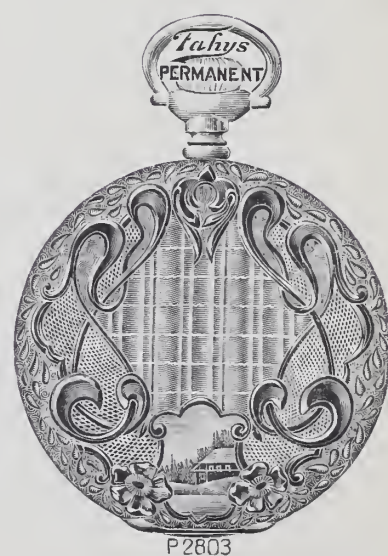

All of our cases are made with our patent one-piece pendant, which eliminates all solder. This patent is controlled by us exclusively.

JOSEPH FAHYS & CO.

NEW YORK

BOSTON

CHICAGO

SAN FRANCISCO

"STRIKE WHILE *the* IRON *is* HOT"

Make Money --
Good
Honest
Dollars



By buying diamonds from us you get the best value obtainable, so you can sell them at a fair profit, and at the same time give your customer proper value for his money

J. R. WOOD & SONS

DIAMOND CUTTERS

2 Maiden Lane, Corner 170 Broadway

NEW YORK

SAFETY



Perfect Safety

from dissatisfied customers is assured to those retail jewelers who handle our wedding rings.

Don't be left "out at sea" by selling rings not up to quality represented, or cast rings that do not wear properly.

We invite you to "ride ashore" to absolute safety.

J. R. WOOD & SONS

WEDDING RING MAKERS

2 Maiden Lane Corner 170 Broadway

NEW YORK

The Big Dipper

Will Dip Up Profits For You



THE
BEST IN EVERY
GRADE

CHICAGO
701 Heyworth Bldg.

Ask your Jobber

NEW YORK
Maiden Lane

STARWATCH CASE CO.

LUDINGTON, MICHIGAN

COPYRIGHTED BY T. F. KENNEDY



No. 69.



No. 48.



No. 40.



No. 61.



No. 64.



No. 63.



No. 71.



No. 67.



No. 73.



No. 31.



No. 44.



No. 66.



No. 99.



No. 22.

When you DO have a call for a fine Emblem Ring it is well to know that Wendell & Co. make the only line of high grade 14K. Rings on the market, that they carry a complete stock and gladly send a selection on memo. Their catalog shows illustrations of the entire line with list prices. They also make special Emblem Rings to order.

WENDELL AND COMPANY

The Special Manufacturers for the Retail Jewelry Trade

103-105 WILLIAM STREET, NEW YORK

57 WASHINGTON STREET, CHICAGO



The only manufacturers who make College Fraternity Pins for the trade. A complete assortment always in stock. Illustrated catalog shows the entire line with list prices. Manufacturing pins for local sororities and fraternities a specialty. Designs cheerfully furnished.



Did you ever know a good thing that was not imitated?



“Fashion”

Collar Pins



PATENTS PENDING

FULLY COVERED, ALL RIGHTS RESERVED

An Absolutely New Article which Sells at Sight. Try It.

MANUFACTURED IN ROLLED PLATE BY

Wolcott Manufacturing Co.

71 Peck St., Providence, R. I.

New York Office, 14 Maiden Lane

MANUFACTURED IN 10KT. SOLID GOLD BY

JOHN T. MAURAN MFG. CO., Providence, R. I.

SUITABLE AND SALABLE GOODS FOR EASTER

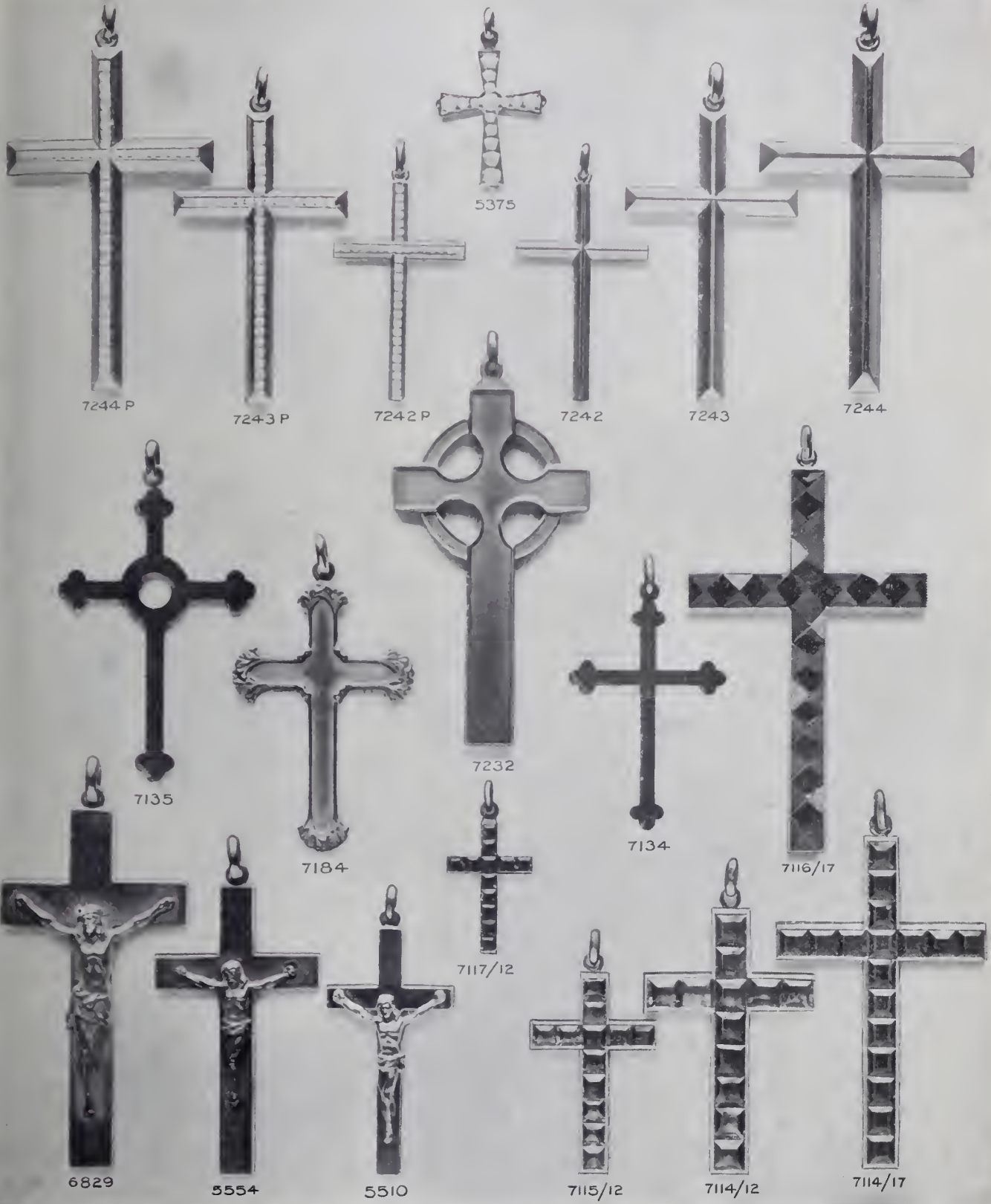

T. W. ADAMS & COMPANY

11 JOHN STREET
NEW YORK

Factory
83 UNION STREET
NEWARK, N. J.

TRADE A 14 K MARK

Manufacturers of 14K. Exclusively

Chicago Office
103 STATE STREET

ILLUSTRATIONS SHOWING FULL LINE FURNISHED UPON APPLICATION



31



32



33



34



35



36



37

12 SIZE
SOLID
GOLD
Dueber Cases
WHICH ARE SURE
TO PLEASE.

A Few Words About Mainsprings

Spectacle and Eyeglass Strap Plier No. 105

Price, each, \$1.25

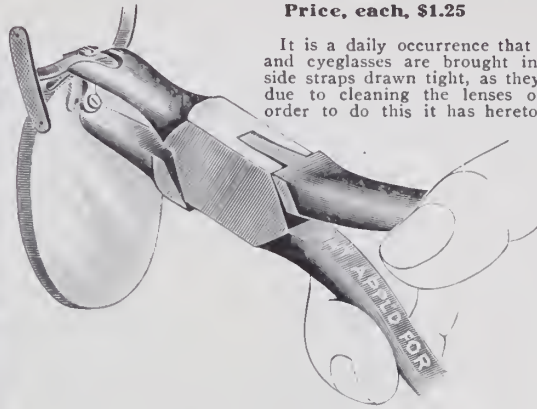

It is a daily occurrence that frameless spectacles and eyeglasses are brought in to have the small side straps drawn tight, as they have become loose, due to cleaning the lenses or other causes. In order to do this it has heretofore been necessary to remove the lenses from the mountings, and as all know, this very often results in breaking or chipping the lenses.

By the means of this plier this can be avoided and the work quickly done.

All that is required is to loosen the screw two or three turns, clamp the frame as shown in the illustration, and bend the straps to the lenses. Retighten the screw, and the work is done.

DO NOT NEGLECT to loosen the screw, as otherwise a good job cannot be done, and the lenses are likely to be broken.

Made of best quality Swedish steel, nickel-plated.

There is no article of material used by the watchmaker or the watch repairer about which, if he be a careful and thorough workman, he feels more solicitous than the *Mainspring*. Next to the fragile watch glass, the mainspring is more frequently replaced than any other article used in watch repairing. While the percentage of breakage is high in all watch springs, it jumps into appalling proportions when they are of an inferior quality, unless their temper is so low as to make them almost useless, and certainly of little value in watches that are to serve the purpose of timekeepers. When we offer you the *Ulysse Sandoz Robert* spring, we feel confident that you are getting the best that skillful hands and lifelong experience can produce.

Made for all American Watches. Per dozen, \$1.25

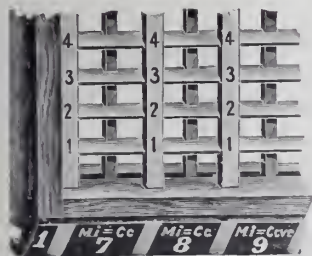

Top View, Showing Skeleton Frame of Drawer. Accumulation of dust and chips is impossible.

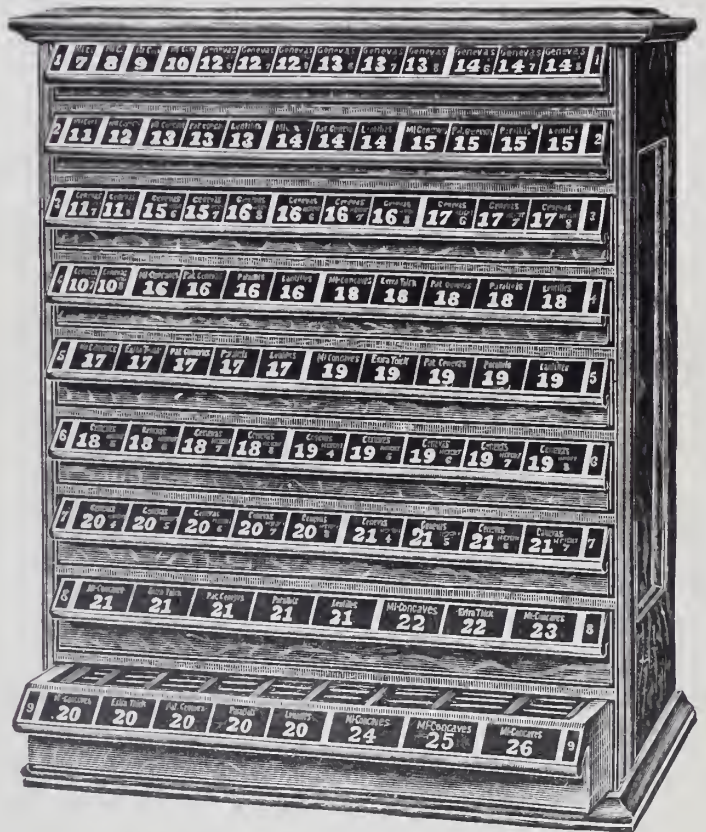

Echarco Watch Glass Cabinet No. 15 (Patented)

Price, each, \$16.00

This cabinet has many new features not found in any other. Novelty and usefulness are the chief arguments in its favor. CONSTRUCTION AND MATERIAL.—The cases are made of oak, finely finished and of attractive appearance. Sides are paneled. Partitions of hawthorn and put together in best manner possible.

PARTITIONS are skeleton, preventing accumulation of dust, chips, etc.

BOTTOMS of cabinets are hollow to receive chips, dust, etc.

ARRANGEMENT FOR GLASSES.—The 9 drawers contain 1,547 spaces to hold glasses in upright position.

Labeling of drawers as shown in cut is on the pulls of the drawers and done in gold bronze on black background.

DIMENSIONS.—24 inches wide, 29½ inches high, 12 inches deep; weight, 45 lbs.; with packing case, 75 lbs.

The construction of drawers, the arrangement of partitions to economize space and weight, and the novel method of showing contents on drawer-pulls are all prominent characteristics and extremely well thought of.

FOR SALE BY ALL JOBBERS IN THE UNITED STATES AND CANADA

HAMMEL, RIGLANDER & CO. 47-49 Maiden Lane
New York

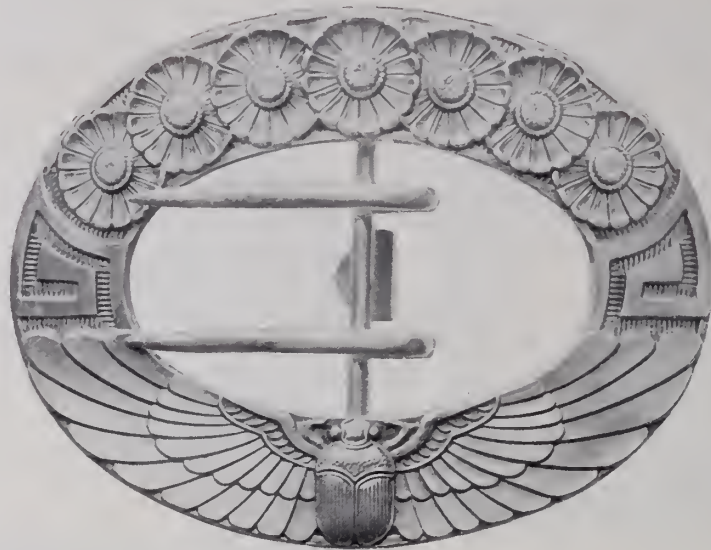

OUR new Buckle and Belt Pin Catalog is now ready and will be sent out in a few days. If you do not receive one, we will gladly send you a copy on request.

We met with such great success with our Buckles that we were encouraged to add from time to time a great many new pieces until we now have as complete and comprehensive a line as any jeweler could desire.

The accompanying illustration suggests one part of the line that we have developed in which is embodied the Egyptian character of ornament.

These Buckles are of heavy weight and no expense has been spared to give them the finest finish possible.

We take this occasion to thank the trade for the support they have given this part of our line in the past and would ask for a continuance of their favors.

R. BLACKINTON & CO.

Established 1861 TRADE  MARK SILVERSMITHS
 FACTORY, NORTH ATTLEBORO, MASS.
 3 Maiden Lane, New York

WHITING MFG. COMPANY

Silversmiths



The Situation

The Whiting Company, being in close touch with the jewelry trade of the entire country, naturally find themselves exceptionally well informed as to the prevailing business conditions and sentiment.

This knowledge leads them to the belief that in these times of "close buying" it is incumbent upon the retail dealer to make his stock more than usually attractive by the addition to it of such goods as shall compel his customers' attention.

For this reason the Whiting Company have confined themselves this season to the production of such goods as shall be absolutely convincing, owing to their moderate price combined with their excellence of quality and individuality of design.

**BROADWAY AND NINETEENTH STREET
NEW YORK**

**SAN FRANCISCO, CAL.
717 Market Street**

TO MEN WHO SMOKE

STERNAU SMOKERS' ARTICLES

appeal strongly, because they are handsome, convenient and useful.

Jewelers should stock Sternau Smoking Sets, Ash-receivers, Match-holders, etc., which are salable *throughout* the year.

Each style has the necessary elegance demanded by the jewelry trade.

The Ash-receiver, with Match-box Holder and two Cigar-rests shown here, is novel.

Let us prove our wares will be profitable for you to sell. Catalogue 21 Y sent on request.

S. STERNAU & CO.

Makers of Fancy Teakettles, Chafing-dishes and their Accessories, Alcohol-stoves, Candlesticks, Coffee and Tea Pots, etc.

New York Showrooms
BROADWAY, COR. PARK PLACE
Opposite Post-office

Office and Factory
195 PLYMOUTH STREET
BROOKLYN, N. Y.

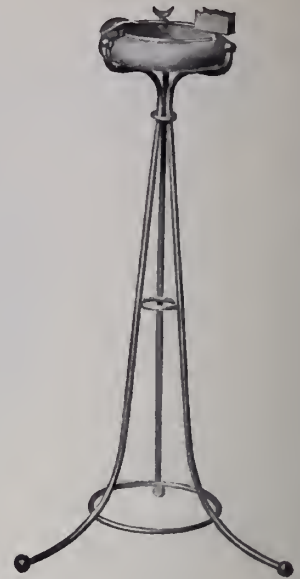

No. 927

Height of Stand and Ash Receiver, 24 $\frac{3}{8}$ inches; diameter of Ash Receiver, 6 inches.

Made in Polished Brass, Old Brass, Nickel-plate, Copper and Silver-plate.



WE show herewith a new style bag—an exceptionally strong, stylish, snappy article.

Our new Spring line is complete—covering the entire range of bags—all shapes, all the different styles of mesh—the largest assortment of frames ever shown. Every piece stamped. W. & D. an absolute guarantee of satisfaction.

Your Jobber has them.

WHITING & DAVIS
PLAINVILLE (Norfolk Co.), MASS.

New York Office, 7 Maiden Lane

"IF FOR ANY REASON"

THE LINE THAT QUALITY BUILT

We show the Largest Line of Cameo Fobs Bracelets La Vallieres and Friends on the Market

Our Chain Fob Line is a complete Line in itself. We are always showing New Goods and incidentally selling the up-to-date Jobbers



L 12041

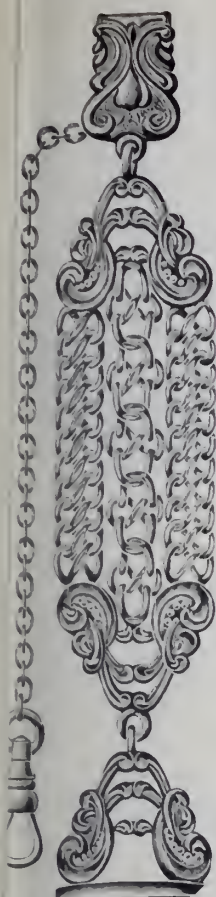

N 134/62



N 104/54

AUSTIN & STONE

INCORPORATED

ATTLEBORO

MASS.

SOLD DIRECT TO THE RETAIL TRADE ONLY

FEATURES OF OUR LINE

The UNIQUE, ARTISTIC and UNUSUAL, together with BEST WORKMANSHIP, SUPERIOR QUALITY and PERFECTION IN FINISH

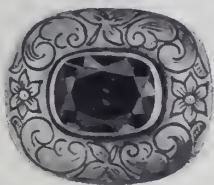

1592.

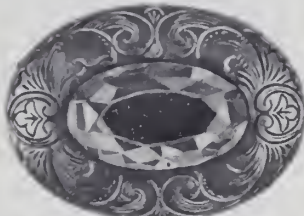

1598.



1138.



2215.



1000.

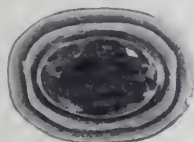

1511.



1636.



1805.

Brooches in gold filled or sterling silver, the gold filled finished in rose or dark green (antique). The sterling in French grey or oxidized. We use finest imitation stones and can furnish any stone or color required.

We Manufacture in GOLD FILLED and STERLING SILVER

BROOCHES, HAT PINS, COMBS, HANDY PINS, WAIST PIN SETS, BARRETTES, SCARF PINS, VEIL PINS, LINKS, BUCKLES, SASH BROOCHES, BRACELETS and NECKLACES.

C. RAY RANDALL & CO., North Attleboro, Mass.

NEW YORK OFFICE, No. 7 Maiden Lane

SAN FRANCISCO OFFICE, Henry M. Abrams Co., No. 717 Market Street

Address all orders and communications to Factory, North Attleboro, Mass.



W. H. SAART
President



GEO. J. KELLEY
Treasurer



F. B. PLATT
New York Representative



F. R. TRUELL
Western Representative

The Four Men who Have Been Instrumental in Making THE W. H. SAART CO.

ATTLEBORO, MASS.

The Leading Sterling Silver Novelty House in the United States

Bags Buckles Sash Pins Vanity Cases Hat Pins

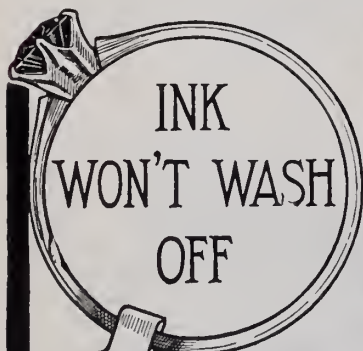

TAG YOUR RINGS WITH WASHABLE TAGS

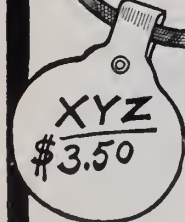

IDEAL TAGGING OUTFIT COMPLETE, ONLY \$2.50

- 1,000 Tags and Eyelets, . . . \$1.50
- 1 Pair Ideal Pliers,75
- 1 Bottle Waterproof Ink,25
- 1 Neat Hardwood Box, with catch fastener

The IDEAL CELLULOID TAG is something that every jeweler should have, BECAUSE IT SAVES TIME—AND SAVES MONEY.

And because it gives your rings a more attractive appearance.

You don't have to take off the tags when you wash or polish your rings, because the ink that goes

with each outfit is waterproof, and won't wash off. No danger of getting the tags mixed and getting them on the wrong ring.

The Ideal has a large flat writing surface, which makes it better than any other tag.

A complete outfit only costs \$2.50. Better send for it to-day if you want it soon, for the demand is very large.

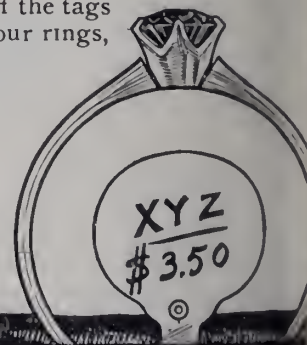
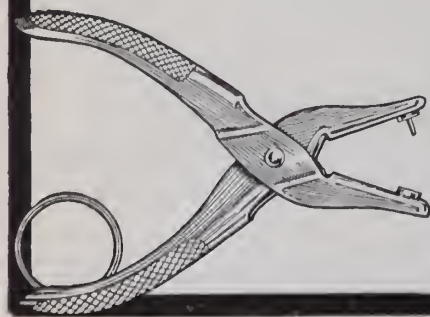

Bastian Bros. Co.
30 South Avenue, ROCHESTER, N. Y.

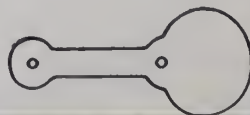

POSITION OF TAG WHEN RING IS IN TRAY

COMPLETE YOUR STOCK WITH RIGHT GOODS

GOLD RINGS

Gold Scarf Pins

Gold Brooches

A Handsome Line of Seamless Wire GOLD FILLED RINGS

All ready for prompt delivery to the Jobber

OSTBY & BARTON CO.
PROVIDENCE, RHODE ISLAND

New York Office
9-13 MAIDEN LANE

Chicago Office
103 STATE STREET

NEW YORK, 9 Maiden Lane
CHICAGO, 103 State Street

BATES & BACON ATTLEBORO MASSACHUSETTS

THE LEADING HOUSE FOR HIGH-GRADE GOLD-FILLED CHAINS,
LOCKETS AND BRACELETS

Something New for Easter!

THE "WINNA" BRACELETS
Strongest secret joint and catch on the market

SOME OF OUR NEW DESIGNS
ORDER OF YOUR JOBBER



F 450
E 22



L.1261



L.1262

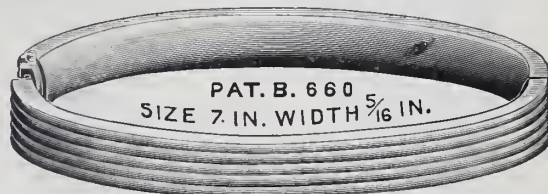

PAT. B. 660
SIZE 7 IN. WIDTH 5/16 IN.

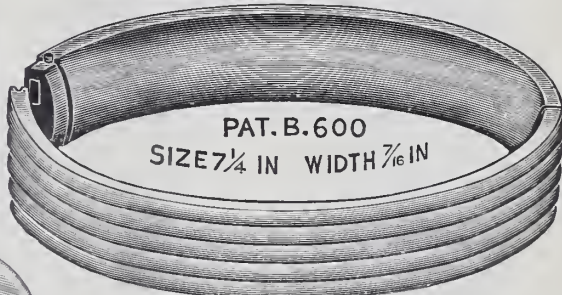

PAT. B. 600
SIZE 7 1/4 IN WIDTH 7/16 IN



PAT. B 662
SIZE 7 1/2 IN. WIDTH 3/4 IN.



PAT. B. 661

The Best Selling "Thread" Pattern in the Trade



The SMITH "PILGRIM"

There never has been a more artistic and lasting design than the Smith "Pilgrim." It is characterized by simple elegance, refinement and dignity of design, and grateful absence of over-ornamentation. The Smith "Pilgrim" pattern will remain permanently in demand. Include "Pilgrim" in your stock. It is without question the best selling "thread" pattern in the trade to-day. Made in all the fancy pieces.

FRANK W. SMITH CO. MANUFACTURERS OF STERLING SILVERWARE Gardner, Mass.



TRADE MARK



The Original Carmen Adjustable Bracelet

With 20 years' experience and the best factory equipment that can be procured, we are able to produce

THE BEST IN THE WORLD FOR THE MONEY

The stamp, "The D. F. B. Co.," is a guarantee of quality and up-to-date designs. Ladies' and Gentlemen's Chains, Fobs, Lorgnettes, La Vallieres, Hat Pins, Chatelaine Pins and Bracelets.

THE D. F. BRIGGS COMPANY

ATTLEBORO, MASS.

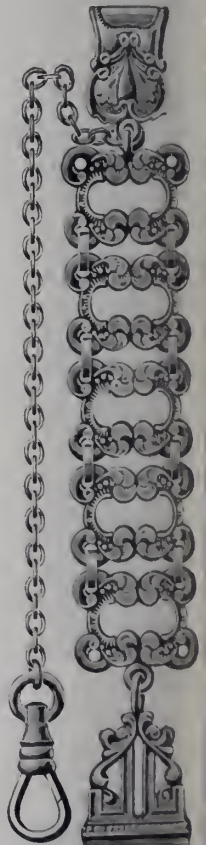

NEW YORK OFFICE
180 Broadway

CHICAGO OFFICE
Heyworth Bldg.

ST. LOUIS OFFICE
Mermod & Jaccard Bldg.

LONDON OFFICE
118-122 Holborn E. C.

¶ A Word to the Wise.

¶ We did not realize, when we first decided to specialize and demonstrate to the jewelry trade that we could do their work better than they have had it done before, that we would receive such substantial support from the trade.



H. F. GRUSCHOW
Designer and Compiler of Catalogs

¶ So much for supplying a long felt want--to wit, a Jewelry Catalog Department, conducted by an experienced jewelry man, backed by one of the largest and best equipped photo-engraving and printing houses in the country.

¶ The reproduction of jewelry, silverware, clocks, etc., is considered the most difficult of all work that comes within the scope of photo-engraving.

¶ We like difficult work. It gives us desired opportunities to display our ability.

¶ See next page for sample of our work.

PENINSULAR ENGRAVING COMPANY
DETROIT - MICHIGAN

Examples of Three-Color Process Work

See previous page



Made direct from
the goods

Printed and Engraved by
Pennington Engraving Company
Detroit, Mich.

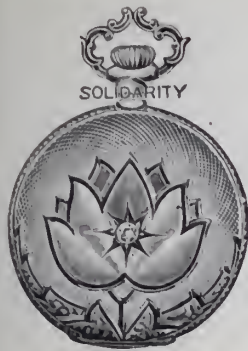

MARGUERITE

MR. RETAILER:

That department in our factory called: "CREATION CORNER" is working overtime.

We simply won't stop creating.

It is just as natural for us to create

SNAPPY GOLD WATCH CASES, as it is for a "live wire" to spit sparks.

Some of our prettiest creations will blossom in April and any Jobber will gladly send you a few.



MARGUERITE

Solidarity Watch Case Company

Established 1885

54 Maiden Lane, New York

General Selling Agents:

JOHN W. SHERWOOD

::

::

FRANK E. HARMER

"Kotobuki"

(Pronounced Ko-to-bû-ki)

THE JAPANESE WORD FOR LONG LIFE

The Popular Craze in

SCARF PINS

MANUFACTURED IN 14 KT. GOLD BY

VAN DUSEN & STOKES CO.

MAKERS OF ORIENTAL JEWELRY

IMPORTERS OF CORAL AND SEMI-PRECIOUS STONES

1123 CHESTNUT STREET

=

=

=

=

=

PHILADELPHIA

Price in 14 Kt.
\$3.00

Price in 14 Kt.
\$3.00



THE Annual Elections of the B. P. O. E. are approaching. Presentation Pieces will be in demand. We are headquarters. Send for selections of fine Jewels, Elk Charms and Buttons. You will make good sales and add to your reputation for having "The best in the line."

HENRY FREUND & BRO.

"Sellers of Sellers"

71 Nassau St., New York

The "Rose,"  our trade-mark, is a symbol of quality and excellence



The Bowden Rings

ARE COMPLETE IN VARIETY, CORRECT IN QUALITY AND PERFECT IN FINISH. WE MAKE EVERY VARIETY OF FINGER RINGS.

J. B. BOWDEN & CO.,

1 Maiden Lane,

NEW YORK.

The "Bryant" Rings.

WE have made the **Bryant Rings** for 50 years, and know how to make first class goods. The stone setting—which every retailer knows is a very important part of the work—we give special attention to. The **Bryant Rings** will help your reputation as a first class Jeweler.



TRADE-MARK

M. B. BRYANT & Co.,

No. 7 MAIDEN LANE,
NEW YORK.



4715
12 in.



4660
10 in.



4172
10 in., 12 in.



4782
8 in., 10 in., 12 in.

We are makers of the "Wedgwood" Sterling Silver-mounted Plates and offer an assortment of 74 leading Souvenir and historical subjects for selection.

We also have a large line of Sandwich and Fruit Plates, varying from \$10 to \$50 each.

Shall be pleased to quote prices on same

Frank M. Whiting & Co.
SILVERSMITHS

320 Fifth Ave., N. Y. No. Attleboro, Mass.



4562
8 in., 10 in., 12 in.

**COMBS
GAIN
FAVOR**



**'WITH'
WARMER
SUNS**

THE TENDENCY to discard the hat when warm weather comes, adds to the importance of the coiffure so that Combs receive emphasis. The very attractive showings of Combs here include Oriental and Egyptian designs, Shell Cameos and effects in Amethyst and Topaz. These goods are so priced that the dealer can sell them from \$3.00 to \$7.50 and realize a good profit.

D. Lisner & Co. *Creating Importers of* **Jewelry Novelties**
One-Forty Fifth Avenue, cor. 19th St., NEW YORK

TRADE



MARK

A FEW OF OUR POPULAR SELLING PATTERNS FOR THIS SEASON

SEND FOR SELECTION

TRADE



MARK

Pearl
and
Diamond
Effects

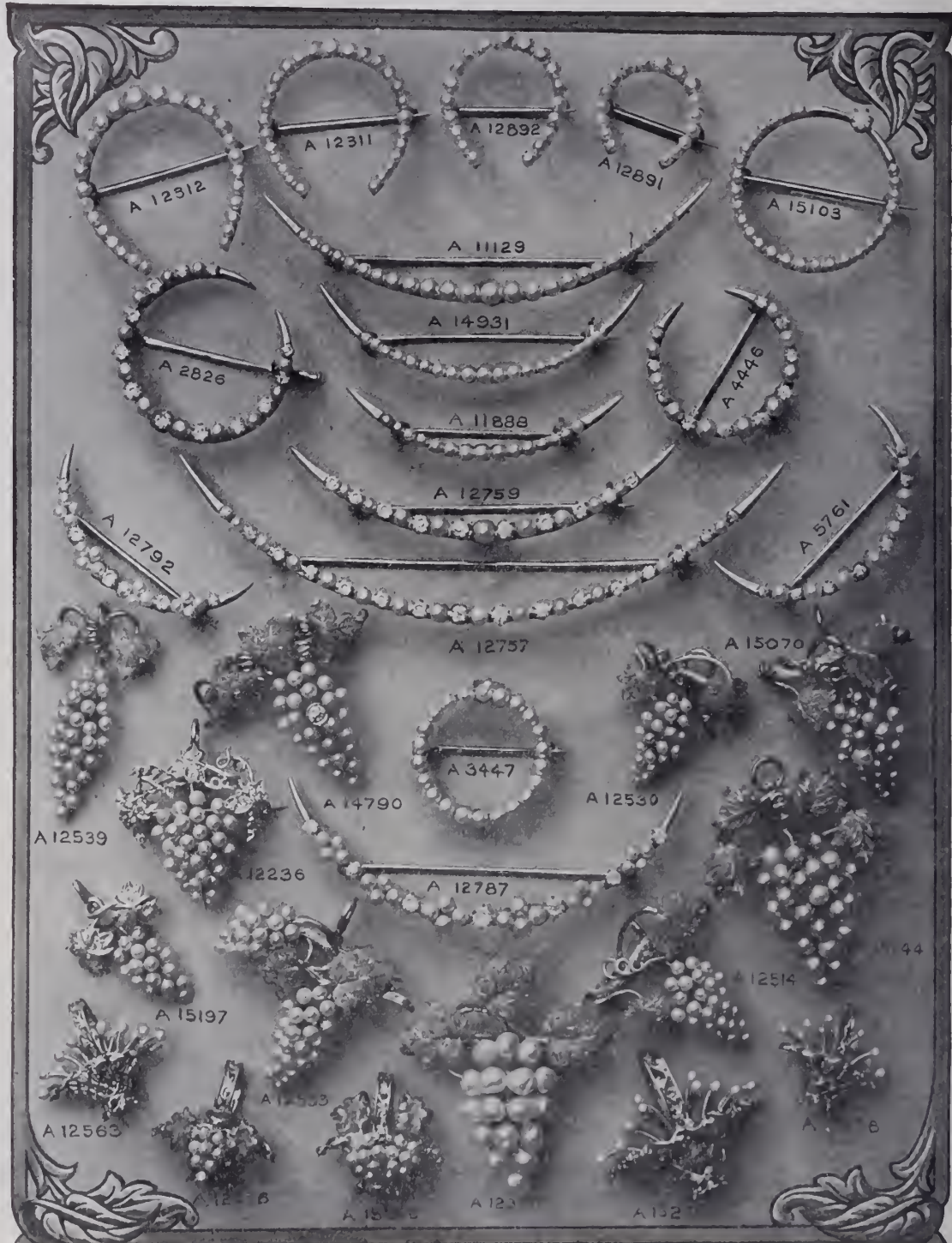

Brooches
Pendants
Scarf Pins
Necklaces

ABEL BROS. & COMPANY

ABEL BUILDING

64-66 John Street

107-109 William Street

NEW YORK

BRANCHES—LONDON PARIS IDAR OBERSTEIN GABLONZ AMSTERDAM ANTWERP

TRADE



MARK

TRADE



MARK

The KREMENTZ MATCH BOX

made expressly for paper matches, in 14-Kt. Gold and Sterling Silver, with the following finishes:
Roman, polished, engraved, engine turned and the Krementz gun metal finish.

Open



Side View
Closed



Order No.
in 14-Kt. Gold
2117

Front View
Closed



Order No.
in
Sterling
Silver
2043

The side and front views show its compactness. It opens and closes easily and fits the vest pocket, taking very little space.

KREMENTZ & CO.

Manufacturers of

Fine Gold and Enamel Diamond Jewelry in 14-Kt. Only

MADE EXCLUSIVELY FOR FINE RETAIL JEWELRY TRADE

BRANCH
San Francisco Office
722 Shreve Bldg.

Factory and Main Office
NEWARK, N. J.

BRANCH
New York Office
1 Maiden Lane

FOBS: HISTORIC, ANTIQUE AND ROMANTIC



A GOOD FOB is more than a Fob. It embodies some special idea, some relation to the past, some romantic conception, some strong human appeal. Such Fobs are prized for more than the stones and the gold. Durand Fobs are examples.



PRICES: \$10.00 to \$220.00

DURAND & CO.

49-51 FRANKLIN STREET
NEWARK, N. J.



OSMUN-PARKER MFG. CO.

MAKERS OF

Fine Pearl and Diamond Goods

338 Mulberry Street
NEWARK, N. J.

ENOS RICHARDSON & Co.

MANUFACTURERS OF

14-K GOLD JEWELRY



- | | |
|-----------------|------------|
| HANDY PINS | TIE CLASPS |
| SAFETY PINS | VEIL PINS |
| BROOCHES | HAT PINS |
| FLAT LINKS | SCARF PINS |
| DUMB-BELL LINKS | BARRETTES |
| FOBS | BELT PINS |

10-K AND 14-K NECK CHAINS AND GUARD CHAINS

PLAIN AND JEWELLED LORGNETTE CHAINS

23 MAIDEN LANE, NEW YORK



The R. S. Cigar Cutter

In Sterling Silver, Plain and Engraved; and 14 k. Gold, Plain and Engraved, also Set with Diamonds.

A Novelty

Unlike all other cigar cutters, this one lies flat in the pocket—does not get out of order.

A Good Article



We Push It

Our advertising makes the customer want it; his friend sees it and he wants it. An endless chain of customers.

A Good Seller



Trade supplied by

Enos Richardson & Co.

23 Maiden Lane, New York.

G. R. HOWE
W. T. CARTER
W. T. GOUGH

ESTABLISHED 1841 BY A. CARTER

F. R. HORTON
F. W. STANBROUGH
H. L. FARROW

CARTER, HOWE & CO.

MANUFACTURERS OF

GOLD JEWELRY

Bags and Purses in Gold and Silver

9-11-13 Maiden Lane, New York

Factory, Newark, New Jersey



SOLID GOLD CHAINS

bearing our trade mark stand for the highest achievement in gold chain manufacture. Plump quality, perfect workmanship, careful finish and attractive designs—all combined—distinguish our product.

WE SELL DIRECT TO YOU

No intermediaries, no corps of salesmen, no unnecessary expenses to add to the price—just the cost of the gold, the cost of making and a modest profit for ourselves enable you to buy the best chains at the lowest price. **SEND FOR CATALOGUE.**

ALOIS KOHN & CO.

16-18 MAIDEN LANE, NEW YORK

Gold Chains of Every Description

THEBERATH & CO., Inc.

Manufacturers of unusual, exclusive and salable designs in 14k. gold

**Brooches, Festoons, Handy Pins,
Barrettes, Pendants, Veil Pins,**

in beautiful plain patterns, or set with precious and semi-precious stones.

KENT & WOODLAND, SELLING AGENTS

12 John Street,

NEW YORK CITY



At Your Service

We can help you to advance your business for 1908 as we are always adding New and Attractive Patterns to our line.

The Keller Jewelry Mfg. Co.

Manufacturers of Fine Gold Jewelry

64 Nassau Street New York

BROOCHES, LINK BUTTONS, LOCKETS, SCARF PINS, BABY PINS, HANDY PINS, WAIST SETS, CROSSES, COMBS, FOBS, TIE CLASPS, CHARMS, LORNETTE CHAINS, NECK CHAINS.

Factory: 8 Lum Street, Newark, N. J.

"THE BRACELET HOUSE"

GOLD BRACELETS of every kind For WOMAN, MISS OR BABY

KENT & WOODLAND

16 John Street, New York

Factory: Newark, N. J.

San Francisco: Julius A. Young

BARRETTESS

Plain
Fancy
Roman Pearl



Hand Engraved
Pierced Effect
Set with Stones

ROMAN - ENGLISH - ROSE

The above cut shows one of our Roman Pearl 10 K. Beauties

Superior to Half Pearls — Will Not Discolor — May be Cleaned

Schultz & Co.

Makers of "Business Builders"



Factory and Office
91 Oliver Street - - - Newark, N. J.
New York Salesroom
12-14 John Street - - - New York City

After July 1, 1908, this Company will change its name to

LAYMAN & STRAUS CO.

Percy M. Layman

Sydney C. Straus

Black Enameled Jewelry

OUR SPECIALTY

THE reports from the fashion centers of the world are that

Black Jewelry

of all kinds, both for mourning as well as regular wear, is the latest fad.

Jewels of all kinds mounted this way show up to their best advantage.

We Make Everything in Black

A. J. Hedges & Co.

MAKERS OF 14 K. JEWELRY

14 John St., New York

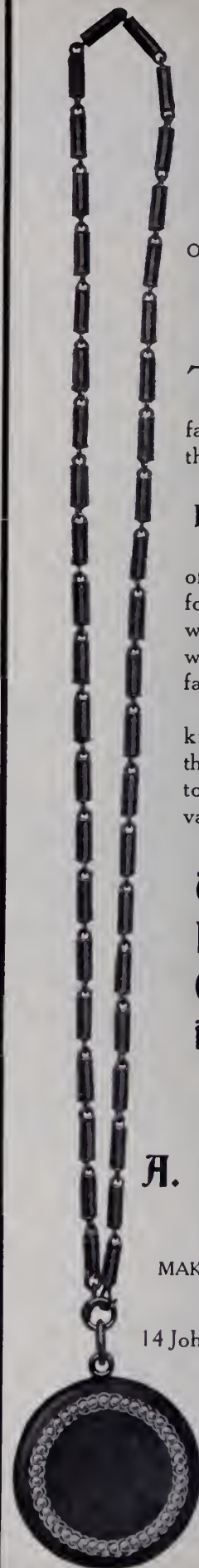

TRADE

14 K

MARK

Day, Clark & Co.

Makers of 14-Kt. Jewelry
23 Maiden Lane
NEW YORK



I. N. LEVINSON, President

ESTABLISHED 1865

H. S. MORRIS, Sec. and Treas.

S. COTTLE COMPANY

Makers of High-Grade Gold, Silver, Gun Metal Novelties

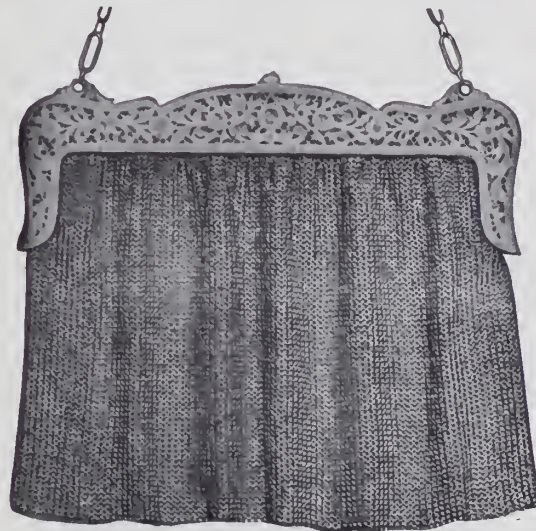

- Mesh Bags Buckles
- Card Cases Chatelaines
- Vanity Cases Sash Pins
- Purses Hat Pins

S. COTTLE CO.

31 EAST 17th STREET
NEW YORK

PARIS, 28 Rue D'Hauteville



ACTUAL SIZE.

SEED-PEARL NECKLACES IN ALL SIZES.

OSMERS-DOUGHERTY CO.

MANUFACTURING JEWELERS

291-293 SEVENTH AVE., NEW YORK
Bet. 26th and 27th Sts. Telephone, 913 Madison.

DEALERS IN
BAROQUES, PEARLS and
FANCY STONES



DESIGNING
AND
SPECIAL ORDER WORK

Grace for the Graceful

YOU WANT what your customers want—and every woman wants a Necklace. You want this Gold Bead line. Even and Graduated. Perfection of Vermicelli trim. Finest of Roman finish. Plain and decorated alternations. Fifteen sizes. It pays to carry them.

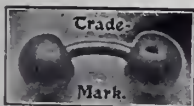

The "SECURITY" Necklace Clasp

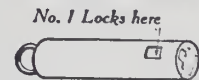

No. 1 Locks here

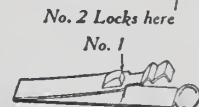

No. 2 Locks here

No. 1

No. 2

Patent applied for.

HEAR IT SNAP

Absolutely Secure and Simple. Cannot Pull Out
LOCKS IN TWO PLACES

Making it Doubly Secure
The Only Perfect Clasp

Ask Your Jobber or Write.

PRICES TO THE TRADE:

No. 1.	10-Karat.	- - -	\$6.00 doz.
" 1-B.	10 "	- - -	7.00 "
" 1.	14 "	- - -	7.00 "
" 1-B.	14 "	- - -	9.00 "
" 2.	10 "	- - -	9.00 "
" 1.	Platinum.	- - -	18.00 "
" 1.	Gold Filled.	- - -	2.00 "
" 1-B.	" "	- - -	2.25 "
" 2.	" "	- - -	2.50 "
" 1.	Sterling Silver.	- - -	2.00 "

The Hoffman Novelty Co.,

"CLINCH"



Safety Catch
for Scarf Pins

No. 2
50 cts.
35 cts.

Does not mar the pin. Nothing to get out of order. Simple and neat.

One turn to the right grips like a vise.

Patent applied for.

..FITS ANY SIZE PIN..

PRICES TO THE TRADE

- No. 1 Gold Plated \$1.50 doz.
- No. 2 Roman Gold 2.00 doz.
- No. 2 14k G'ld Pt'te 2.25 doz.

No. 1, 25c.

Makers, 79-83 No. Pearl St., ALBANY, N. Y.

Important Notice

The jewelry trade is hereby notified that the following manufacturing jewelers have been granted licenses under my pending patents to manufacture and sell the "Fashion" Collar Pins:

- KREMENTZ & CO.
- CARTER, HOWE & CO.
- BIPPART, GRISCOM & OSBORN
- A. J. HEDGES & CO.
- ECKFELDT & ACKLEY
- J. T. MAURAN MFG. CO.
- WOLCOTT MFG. CO.
- ARCH CROWN MFG. CO.
- SCHRADER-WITTSTEIN CO.

The trade is informed that I shall protect our rights under my pending patents to the full extent of the law, and having confidence in the fairness of the trade in general, I believe that I may expect its co-operation by refusal to purchase should other manufacturers than those above mentioned offer "Fashion" Collar Pins in imitation of mine.

Thanking the trade in advance for its consideration, I beg to remain, very respectfully,

CHARLES T. WITTSTEIN,

ARCH CROWN MFG. CO. Camp and Orchard Sts., Newark, N. J.

"If It Is Chopard's Idea, It's Ideal"

ALL
QUALITIES

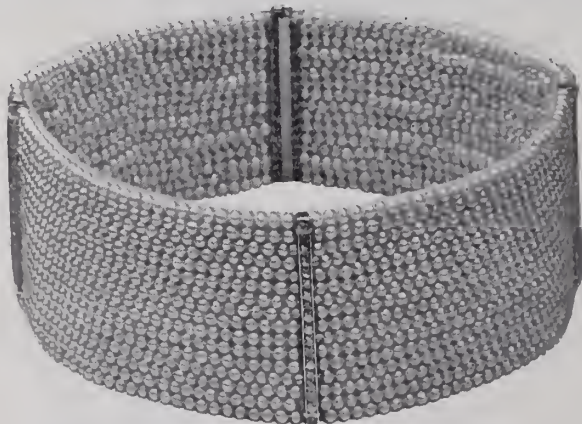

ALL
SIZES

OUR PEARLS resemble others only in name. Here the comparison stops, for in Quality, Lustre and Durability they defy competition. COLLARS, NECKLACES, FAN CHAINS in stock.

Remember our Special Department created for you. For Restringing and Mounting Pearls and Pearl Collars AT MODERATE RATES.

CHOPARD FRÈRES

Factory, 35 Rue des Trois Bornes, PARIS, FRANCE

56 Maiden Lane, NEW YORK, N. Y.



SNOW & WESTCOTT CO.

21 MAIDEN LANE, NEW YORK

JAMES P. SNOW

CHAS. E. WESTCOTT

Makers of Fine Gold Jewelry

ESTABLISHED 1834

S. F. Myers & Co.

WHOLESALE JEWELERS
47-49 Maiden Lane
New York

Fifty years in business. Call on us fifty years hence. We'll be right here.

For the trade only — our new, big catalogue, with 100,000 items, sent free.

THE GREAT AMERICAN JEWELRY CATALOG

Is a publication of real practical value; it truthfully illustrates those lines of merchandise; best adapted to the needs of the *Jewelry Trade*; its reliability is unquestionable.

SAFETY

With implicit confidence you can use it when ordering goods; it insures you against deception; remember, for every dollar's worth of merchandise you buy you are obtaining positive, intrinsic value.

Write for this catalog; it means much to you.

THE OSKAMP-NOLTING CO.

Mammoth Wholesale Jewelers
411-413-415-417 Elm St., CINCINNATI, OHIO



Monograms

INITIALS
AND
FOBS

Our
Specialties

Write for Catalogue
Prices and Discounts

CHICAGO
ART METAL
WORKS

63 Lake Street,
CHICAGO, ILL.

UNIQUE GEMS

SEMI-PRECIOUS CEYLON, URAL and NATIVE
GEMS My Specialty

Prices the Lowest. Sample Papers sent on Request to Reliable Jewelers and Manufacturers.

Louis J. Deacon, Atlantic City, N. J.



SOLID GOLD COMBS

From \$1.50 Upward

A Snappy New Spring Line

in Plain and Engraved Bands, also

New Effects in Pierced Tops

14k.—Everything in Gold Jewelry—10k. Brooches, Barrettes, Buckles, Bracelets, Pendants, Festoons, Emblems, Hat Pins, Fobs, Scarfs, etc.



2 Maiden Lane, New York



While your business is somewhat dull you will find it to your advantage to look up the local order for

CLASS PINS

Write us for Catalogue J 30, and Samples

THE CHAS. M. ROBBINS CO.

MANUFACTURING JEWELERS AND ENAMELERS
ATTLEBORO, MASSACHUSETTS



LA VIGNE TEASPOON



LA VIGNE TABLESPOON



LA VIGNE MED. FORK

The latest and newest in ROGERS FLATWARE

HAVE YOU SEEN IT?

Bright or French Gray. Sample dozen on approval. Write for prices and terms.

JOSEPH IRONS, 35 Maiden Lane

J. H. GALAWAY F. H.
ENGRAVERS
CRESTS, MONOGRAMS and LETTERING
7 Maiden Lane, Rooms 44-45
Established over 35 years



"HOLD-ON" CLUTCH

FOR SCARF PINS AND BROOCHES

14K. GOLD PLATE
SUPERIOR TO ALL OTHERS

Pat. May 20, '02
To Release
Pull the Ball

PRICE 50 CENTS

Pat. May 20, '02
Attached
to Scarf Pin

ADVANTAGES:

1. *It Holds*—The harder you pull, the tighter it holds.
2. *To Release*—Raise the clutch and pull the ball.
3. *All One Piece*—No parts to lose.

HOLD-ON CLUTCH CO. 33 GOLD STREET NEW YORK

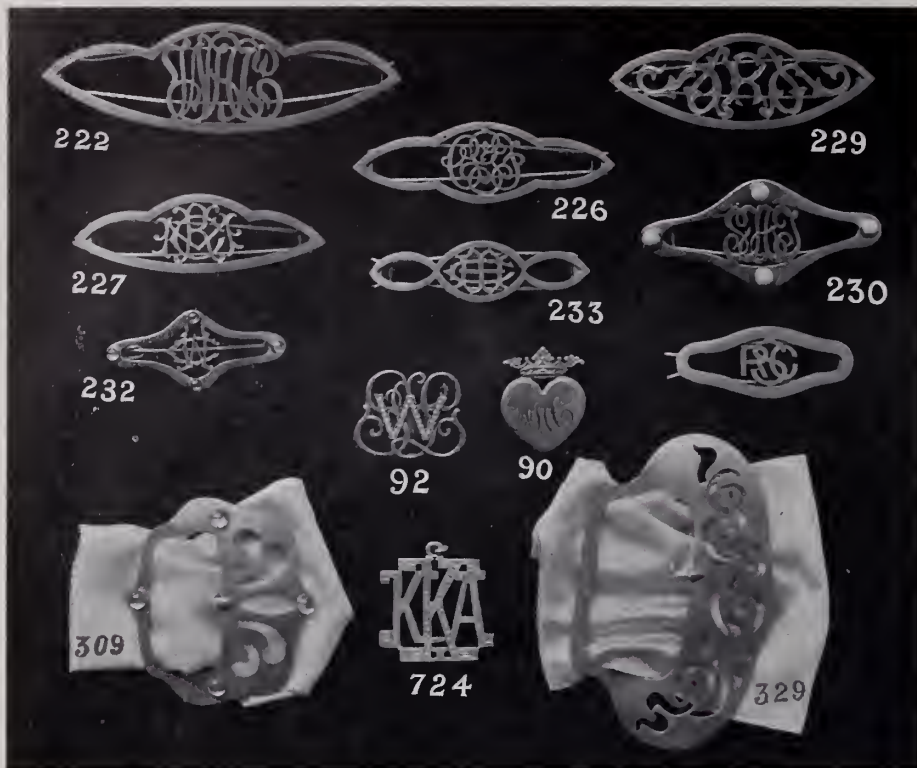

SOMETHING NEW IN LADIES' HAIR ORNAMENTS
MONOGRAM BARRETTES
 in Solid Gold, Sterling Silver and Gilt
 TO THE TRADE

Monogram Fobs, Belt Buckles, Brooches, and all kinds of MONOGRAM WORK our Specialty

WALDRON & CARROLL Mtg. Jewelers 34 Warren St., New York

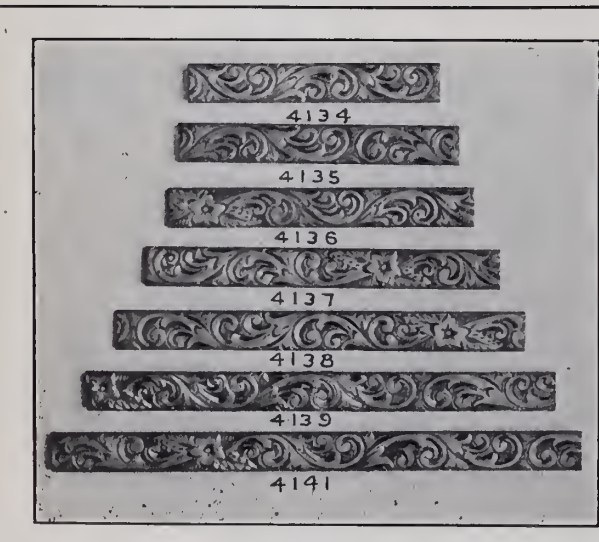

Seamless Gold Plated Pins

FOR EVERY USE

Variety of Patterns in Plain and Engraved, in lengths one to four inches : : : : :

GUARANTEED GOLD FRONT, BACK AND SIDES

SEND FOR SELECTION

Maintien Bros. & Elliot, Makers of Jewelry for the Jobbing Trade

NO. ATTLEBORO, MASS.

New York Office, 9-11 Maiden Lane

Pierceless Ear Screws

We are making a complete line of these popular goods. Samples upon request.

Also a new line of

- Brooches
- Scarf Pins
- Baby Pins
- Links
- Studs
- Crosses
- Ear Rings
- Rings
- Neck Chains

We have manufactured Gold jewelry for over fifty years and our goods have stood the test of time.

DON'T NEGLECT TO SEE OUR LINE.

Wm. C. Greene Co.

Established 1849 Incorporated 1906

MANUFACTURERS OF GOLD JEWELRY

101 Sabin Street,

Providence, R.I.

DIAMOND MOUNTINGS

of any description in gold and platina

Order Work a Specialty

HENRY BASCHKOPF

47-49 Maiden Lane

New York, N. Y.

Don't Worry About the Scarcity of Money

If you need any send us your surplus stock of Diamonds, Watches, Jewelry, Old Gold and Silver, and get our certified check by return mail. If amount is not satisfactory goods will be returned in same condition as received. Strictly confidential. Correspond or call. Telephone, 5202 John.

New York Jewelry Purchasing Co.
 106 Fulton Street, New York



Fans

in endless variety from the cheapest to the best, for weddings, confirmation and graduation.

SEND FOR SELECTION, MENTIONING PRICE

Novelties for Easter



in Necklaces, Buckles, Belt Pins, Brooches, Hat Pins, Collars, in sterling silver and gold plated, set with semi-precious and imitation stones: lapis, coral, amethyst, topaz, etc. Also an extensive line of Cameo Jewelry.

Pearl Drop Earrings

LEWY & COHEN

IMPORTERS

530 Broadway Cor. Spring St. NEW YORK

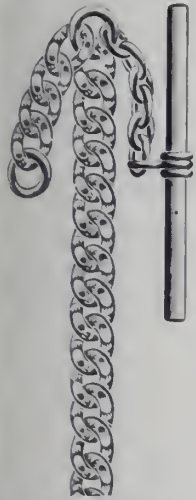

O. M. DRAPER CHAINS

ALL KINDS OF VEST CHAINS
PRINCESS, NECK AND GUARD CHAINS

We do not make as much noise as some of our friends but we are "there with the goods" and the *Jobbing Trade* handling our product for the last half century, know that our QUALITIES are genuine and can be depended upon, that our FINISH is unparalleled and that our prices are consistent.

If you do not handle O. M. DRAPER GOODS, we both lose.
We sell only to the Jobbing Trade.

Estate of O. M. DRAPER
Factory, No. Attleboro, Mass.

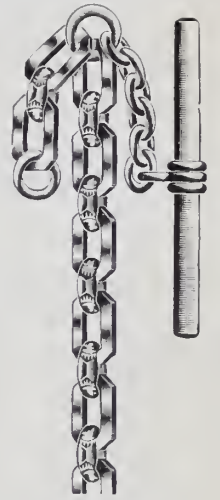

NEW YORK OFFICE
37 Maiden Lane

SAN FRANCISCO
506 Chronicle Building

The Simplicity Collar Supporter

A practical and ornamental novelty. Only one pin to fasten. The stiff bar acts as a support to the Gibson collars now so extensively worn, and conceals the two ends where they come together. All sizes. Neat and convenient. Look for our trade mark and accept no others. **BIG SELLERS.**



MILLER, FULLER & WHITING CO.
MANUFACTURING JEWELERS

VEIL, CUFF AND BABY PINS, CAMEOS

SWASTIKA Buckles, Bracelets, Buttons, Charms, Brooches, Barrettes, Combs, Hat Pins, Scarf Pins, Leather Trimmings.



NORTH ATTLEBORO, MASS.

New York Office *Samples only.* We Sell to the **Jobbing Trade Only**

Machine cut work a specialty

We are using the most approved and modern reducing machines, guaranteeing the finest work.

Crees & Court, Die Sinkers

21 EDDY STREET, PROVIDENCE, R. I.

- DIES -
- DIES -
- DIES -

Designs cheerfully submitted for jewelry, silverware, medals, emblems, brass goods, etc.

WRITE TO-DAY FOR A SELECTION

LOCKETS ONLY

Registered



U. S. Pat. Office



Pat. Applied for
NUMBER
8482

Latest Design Appropriate for Easter

WIGHTMAN & HOUGH CO.

NEW YORK OFFICE
3 Malden Lane

Main Office and Factory } 7 Beverly St.
PROVIDENCE, R. I.

EVERYTHING IN LOCKETS AND CHAINS.

THE BASSETT JEWELRY CO.,
PROVIDENCE, R. I.

Send for the Latest Styles in MONOGRAMS AND INITIALS

as manufactured by

THOMAS J. DUNN CO.

101 Chambers St., New York

Makers of exclusive styles in

MONOGRAM FOBS

in Gold, Sterling and Rolled Gold Plate.
Our 1908 Ladies' Belt Buckles are most
original and artistic.

Specialties in the Monogram and Initial line.

Send for Illustrated Sheets.



TURQUOISE

Matrix - Turquoise

Best the World Produces

WE ARE prepared to furnish
to the trade Matrix-Tur-
quoise in all shapes and sizes.

Exquisite Color and Markings

We cut Turquoise to order

Mines at Mojave County, Arizona

THE ARIZONA
TURQUOISE MINES CO., Inc.

Cutting Works and Sales Office
171 Broadway, New York

SEND FOR CATALOG

Telephone 5728 Cortlandt

10K. GOLD BRACELETS

New and Original
— Designs in —

**BANGLE, JOINT
AND
CATCH SIZES**

Scarf Pins, Ladies' Rings
Earrings and Handy Pins

in a great variety
of designs

TRADE MARK

THE
Edwin Lowe & Co., Inc.
F.W. BODWELL, Pres. & Gen. Mgr.

116 Chestnut St., PROVIDENCE, R. I.

New York Representative: Western Representative:
E.T. Wilson, 180 Bway. S. H. Brower

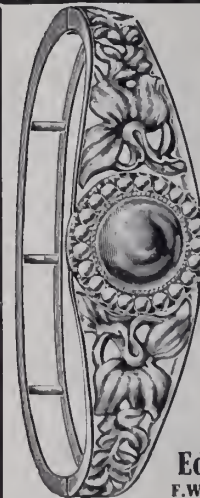

J. E. ROHRBECK
MANUFACTURER
40 FULTON ST.
NEW YORK, N. Y.

Orders Prove Our Goods Sell

Q We make for the Jobbing Trade the following lines of Solid Gold Jewelry:

Rings, Scarf Pins, Studs, Brooches, Charms, Baby Pins, Handy Pins, Chain Sets, Link Buttons, Hair Barrettes, Crosses, Ear Screws, Pierceless Drops, Cameos in all styles, etc.



Insist upon seeing the designs of Gold Jewelry made by the

E. L. Spencer Company

95 CHESTNUT STREET
PROVIDENCE, R. I.

NEW YORK OFFICE
9-11-13 MAIDEN LANE

(SAMPLES ONLY)



CAMEOS

In these times the jobber, in order to stimulate his business, must create a run on some special article. And just now, why not the Cameo? It is sure to be a good leader and is being extensively advertised by a number of manufacturers.

We are mounting stone, shell and coral Cameos in scarf pins and brooches. A good assortment of Cameos should be found in every line this season. Let us send you a few samples on memorandum.

R THIS TRADE-MARK on every piece of jewelry that leaves our factory. A medium-priced line of 10K. jewelry that has stood the test. Will say no more, but let us show you and be convinced yourself.

Send for further information regarding our extensive line.

W. E. RICHARDS CO.
Manufacturers for the Jobbing Trade
ATTLEBORO, MASS.

New York Office: 12-14 John Street *Samples only*

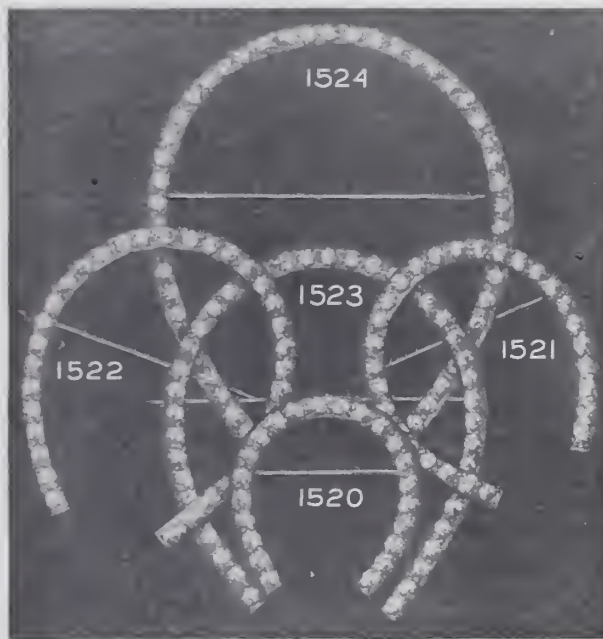

Sterling Silver Horseshoes

14 Karat
Gold Finish
set with
Whitestones
or Pearls

*Write for Selection
Package with
Prices*

Wachenheimer Bros. 36 GARNET STREET
PROVIDENCE, R. I.

Roger Williams Silver Co., PROVIDENCE, R. I.

Sterling Only.

RICH DESIGNS :: :: Photos. on Application.

VERIBEST

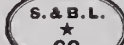
Label  Inside

LOCKETS

Our Label Essentially Necessary
for Discriminating
Jewelry Buyers.
Particularly gratifying to
those who want "Goodasgold"
Guaranteed Locketts
for $\frac{1}{2}$ the investment of solid gold.

"Lederermak"

Exclusively sold by **VERIBEST** Jobbers
Everywhere

Manufactured and Guaranteed by
S. & B. L. ★ CO.

New York City - - - 9-11-13 Maiden Lane
Providence, R. I. - - - 100 Stewart Street
Chicago, Ill. - - - 131 Wabash Avenue



P & B FOBS



ALL STYLES AND PRICES
BOTH RIBBON AND ALL GOLD

WE ARE THE LARGEST MANUFACTURERS OF
ASK YOUR JOBBER FOR THE P & B LINE

Cuff Buttons	Crosses	Tie Clasp
Brooches	Fobs	Baby Pins
Beadnecks	Locketts	Bracelets

NEW YORK OFFICE 65 NASSAU ST.

POTTER &
BUFFINTON CO.

PROVIDENCE, R.I.

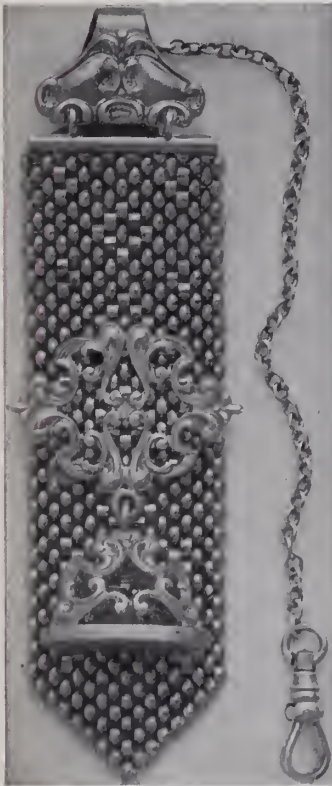

Roller Chain

OUR SPECIALTY

Do not forget that we still continue to show the best line of these goods on the market, in Fobs, Bracelets and Neck Chains. These wear longer, give better satisfaction than any metal fob made, and our designs are up-to-date. Also our line of chains of all kinds find a ready market among the best trade, both in 1-10 and a medium wearing grade.

We also make a nice line of Brooches, Hatpins, Scarfpins, Barrettes, etc., that should demand your attention.

Ask your jobber, and if unable to obtain them from him, advise us who he is, and we will make arrangements for you to get them.

B. S. FREEMAN CO.

ATTLEBORO FALLS, MASS.

Chicago Office, J. T. Edwards, 103 State St., Chicago, Ill.

RIBBONS

plain and fancy designs **Made to Order**,
in large or small quantities, to use with medals and
for club purposes. :: :: :: Correspondence invited.

JOSEPH LOTH & CO., Manufacturers, 65 Greene Street, New York

Perennially Popular

THE best evidence of the popularity of our various lines is the increasing demand for them and our consequent growth. Our jewelry is unexcelled in every quality that contributes to serviceability and appearance. The designs are artistic enough to court that investigation which results in sales.



No. 1117

Ask to see our line of

**CHAINS
CHAIN PENDANTS
CROSSES
AND BRACELETS**

The

**Kenilworth
Bracelet**

particularly, the strongest
on the market.

**DORAN,
BAGNALL & CO.**

North Attleboro, Mass.

OFFICES

New York: 194 Broadway.
Chicago: 42 E. Madison St.
San Francisco: 91 Drumm St.



No. 4397 X1



Pat.
U.S. and
Canada.

A MILLION RINGS ARE NOW worn that are loose on the finger and need Wells Perfect Ring Adjusters to hold them in place. Why not fit these and make a good profit and new customers.

Ask your Jobber for them
Sold in 1 doz. assorted sizes in packages as follows: 10 K. Gold, \$3.75; Gold Filled, \$2.00; Metal, 85 cents.

CHESTER H. WELLS, Jeweler, Meshoppen, Pa.

Manipulation of Steel in Watch Work.

By JOHN J. BOWMAN.

Price, 60 cents; postpaid. Jewelers' Circular Pub. Co., 11 John St., New York.

The Latest Novelty in Cloisonne Enamel

STERLING SILVER WITH BEAUTIFUL TRANSPARENT COLORING

Birth Day Handy Pins



¶ We wish to call particular attention to this line and the rich effect produced with polished silver in combination with the enamel. This is the best hit of the season

Price, \$7.50 per doz. mounted on an easel pad.

SHEPARD MFG. CO., MELROSE HIGHLANDS, MASS.

CORAL HAT PINS

¶ The spring season and Eastertide are here, and as usual there will be a big demand for hat pins. ¶ Coral jewelry is popular in the extreme, and our line of Coral Hat Pins, showing hundreds of new designs, is one of the finest showings on exhibition at present. The prices range from \$6.00 to \$24.00 per dozen.

SELECTION PACKAGES SENT ON REQUEST

M. GUGENHEIM,
IMPORTER

Brooches, Festoon Chains, Combs, Hat Pins, Collars, Jet Goods, Mesh Bags, in German Silver, Gilt Metal and Sterling

NEW YORK OFFICE: 33 Union Square, Decker Building

PARIS: 32 Faubourg Poissoniere

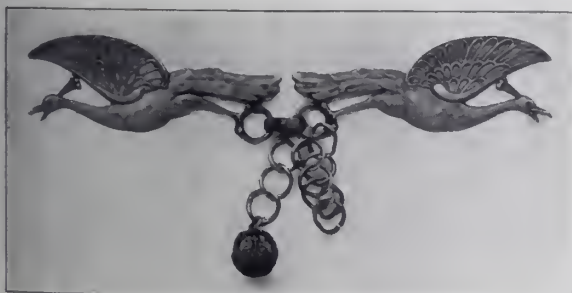

PATENTED
DEC. 31, '07

The "EZ" Catch

FOR

Scarf Pins and Brooches

14 K. Gold Plate Price, 50c. Each

Every One is Guaranteed

PATENTED
DEC. 31, '07



To release push
catch up and pull
ball down.

To release push
catch up and pull
ball down.

ABSOLUTE SAFEGUARD AGAINST LOSS

Samples and prices on application.

FOR SALE BY JOBBERS OR DIRECT BY

U. S. SCARFPIN GUARD CO.
106-108 Fulton Street, New York

HOLDFAST SCARFPIN GUARD CO.
64-66 John Street, New York



306

S. PITZELE

Established 1893

51-53 Maiden Lane, New York

MANUFACTURER OF

FINE DIAMOND MOUNTINGS

Also BRACELETS and DWT. GOODS

SPECIAL ATTENTION GIVEN TO ORDER WORK



325



218

TRADE **14K** MARK



435

CHARLES M. PRIOR, Designer

We have ready many new designs. Call or write. Etching is more popular than ever and we do it in the finest style.

'Phone 1639 Gramercy

24-26 East 21st St., NEW YORK

THE Ægis Case

(PATENTED)

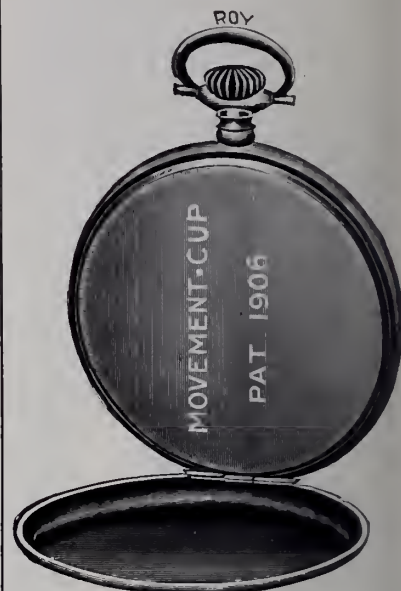

THE ÆGIS is a new creation in gold case making. The center and bezel are in one. Instead of having the ordinary Cap, this case is provided with a rigid metal movement Cup, held friction tight in position. This Cup gives protection to the movement such as cannot be secured with the conventional jointed cap, while dust is thoroughly excluded from the front by means of the one-piece center and bezel.

MADE ONLY BY

ROY WATCH CASE CO.

21-23 MAIDEN LANE

NEW YORK

San Francisco Office, 704 Market Street

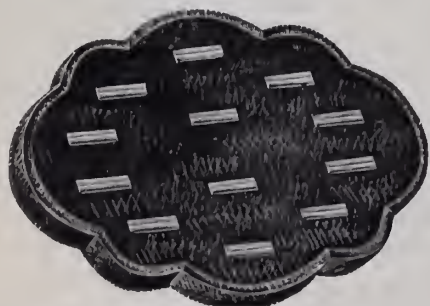

Estimates and Samples Cheerfully Furnished

We Manufacture

Fancy Platforms and Blocks for Window Display.

Jewelry Boxes in many qualities and styles.

Silverware Chests in any combination.

Trays for Show Cases and Travelers' Use, of every description.

Boxes for Silverware, Manicure and Toilet Sets.

Flannel Rolls and Bags for Silverware.

We Re-cover Window Platforms and Trays
PAPER BOXES, TAGS, CARDS, COTTON, FINDINGS, ETC.

WOLFSHEIM & SACHS

Office and Salesroom:

35 MAIDEN LANE (Lorsch Building)
NEW YORK

Factory:

10 GOLD STREET

IMPORTANT ANNOUNCEMENT

RE THE

“Hold-On” Clutch

(Patented May 20, 1902)

Dear Sir:—It having come to our knowledge that several imitations and infringements of our patented “Hold-on” Clutch for Scarf-pins have recently been put upon the market, we respectfully beg to notify you that infringement suits have been and are being brought against the manufacturers of said goods, and also against others handling same.

We also respectfully beg to notify the trade that we shall vigorously protect our patent rights, and caution all dealers that in handling and selling any imitation of our well-known “Hold-on” Clutch, they do so at their own risk.

Respectfully yours,

HOLD-ON CLUTCH CO.

C. P. GOLDSMITH & CO., Proprietors.

**\$ 3000 To \$ 10000
A WEEK
IN YOUR CASH DRAWER**

We can sell for you at auction from Three to Ten Thousand Dollars per week any time of the year.

We can sell all your dead Stock.

We will make you a satisfactory profit above all expenses of the sale.

We will teach you methods of advertising and merchandising that will be worth thousands of dollars to you in your future business.

We never sell shoddy or cheap goods, neither do we misrepresent or make misleading statements about the goods we sell.

We sell your goods; the kind of which you wish to dispose.

Allow us to send you the evidence - facts and figures - backed by the evidence of those we have served - to prove the character of our work.

MITCHELL & TILLOTSON

JEWELRY AND ART GOODS AUCTIONEERS

35 MAIDEN LANE, NEW YORK



It's the Little Things that count.

The dainty little things that appeal at once to the casual observer. If it's useful, as well as ornamental, so much the better. Here is a LITTLE THING, so very useful and so pretty in design and finish, that you have but to show one to make a sale, and it yields a BIG PROFIT. It is called

The Automatic Eye-Glass Holder

Can be used as well for a Pencil Holder. It is made in Enamel, Gold, Silver and Rolled Plate, in a variety of artistic designs. We fully guarantee every Holder. We mean it, and will replace any Holder that fails to satisfy. Samples sent upon request. Send for catalogue.

Est. 1832 **Ketcham & McDougall**, Manufacturers

37-39 MAIDEN LANE, NEW YORK

ALSO MAKERS OF THE LEADING LINE OF THIMBLES.



Practical Course in Adjusting

Published Price, \$2.50

Special Reduced Price, \$1.50, Postpaid

All Jobbers, or
Jewelers' Circular Publishing Co.



The Gillette Safety Razor Set consists of a triple silver-plated holder and twelve double edged, thin, flexible, wafer-like blades (24 keen edges), packed in a velvet lined leather case. Price, \$5.00. Also made in Combination Sets in a variety of styles with toilet accessories retailing from \$6.50 to \$50.00 each.

Would You Have the Present Year Bring You Increased Patronage, Profit and Prosperity?

Do you realize that nearly every hour in the day some man is converted to the easier, quicker and more economical way of shaving himself with the

Gillette Safety Razor?

Our persistent and vigorous advertising in the leading publications of this country discloses — *and will continue to disclose* — beyond all question of doubt, the superiority of the "Gillette." It advocates the advantages of self-shaving and guides the man to your store with a five dollar bill to exchange for the best shaving device in this world.

You can readily see the wisdom of having the "Gillette" ready when he calls. The Standard Gillette Set retails at \$5.00 everywhere. Combination Sets from \$6.50 to \$50.00. Keep a good supply in stock. Write to-day for valuable selling information and prices.

GILLETTE SALES CO., 904 Times Bldg., New York City



Scarf Pin 891
Old English
Set as ordered

Scarf Pin
842—Rose
or Green
Set as
ordered

Neck Chain 296
Old English Chain
Roman Scrolls
16" long
Stones set as ordered
Baroque Pearl
Pendant



Link Button
877—Rose, Ruby
and Brilliants
878—O.E., Ruby
and Brilliants



Link Button
872—O.E., Stones set
as ordered

Easter Suggestions

We have this season many choice designs in Fine Gold Filled Jewelry, suitable for Easter gifts, among which are Neck Chains and Pendants, Locket and Charms, Link Buttons and Bracelets, as well as Brooch, Veil, Scarf and Hat Pins. Our Gold Filled Goods meet the most critical test for high standing.

We mention our Sterling Silver Toilet, Manicure and Table Goods as appropriate Wedding Gifts.



Charm 2982
Rose, Ruby Stones

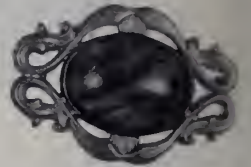

Brooch Pin
3864—Old English, Japanese
Jade Stone



Scarf Pin
884—O.E.
Set as
ordered

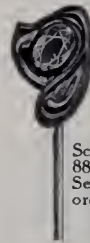

Scarf Pin
886—O.E.
Set as
ordered



Locket
3013—Rose, No Stones
3016—Rose, Red Eyes,
White Mouth



Belt Buckle
3540²—Rose, Ruby Eyes, Stone in Mouth set as ordered, Pin Stem
3540 —Rose, Ruby Eyes, Stone in Mouth set as ordered, Clasp



Charm
2984—Rose, Red Eyes,
White Mouth
2983—Rose, No Stone

Theodore W. Foster & Bro. Co.

Manufacturing Jewelers and Silversmiths

100 RICHMOND ST., PROVIDENCE, R. I.

NEW YORK: 13 Maiden Lane.

CHICAGO: Heyworth Bldg.

CANADA: Kingston, Ontario

THE JEWELERS' CIRCULAR

WITH WHICH ARE CONSOLIDATED
 THE HOROLOGICAL REVIEW
 THE JEWELERS' WEEKLY THE JEWELERS' REVIEW

Vol. LVI.

WEDNESDAY, MARCH 25, 1908.

No. 8.

Burma Pearl Fisheries.

WILLIAM H. MICHAEL, Consul-General, writes from Calcutta as follows in regard to the pearl fisheries of the Burmese coast:

"The supply of mother-of-pearl shells from Mergui and Tavoy islands, which lie off Lower Burma, has been declining so

Inquiries among divers themselves afford no useful information as to the habits of the pearl mollusk. They work more after custom and superstition than by observation. An application was made as far back as 1904-5 by the syndicate which leased the Ceylon pearl fisheries for the grant of a similar lease of the Mergui and Tavoy pearl fisheries and for pearling rights in a block

Scenes at the Ivory Sale in London.

THE growing demand for ivory has caused more than the usual interest to be taken in the annual sales of this product and the sale which took place at Mincing, recently, was the subject of much comment by the newspapers, as well as the subject for illustrated articles in the weekly magazines. To a London exchange we are indebted for the interesting illustrations herewith, which show a section of the ivory floor on the London docks just prior to the sale, and another view of the ivory displayed. In the latter, in the foreground, is a wonderful pair of tusks from Uganda, each about 10 feet in length and weighing about 140 pounds; their value is in the neighborhood of \$1,500. In the two upper corners of this illustration are sketches showing the tusks being measured and gauged to determine their availability as material for billiard balls.

A large part of the ivory sold in London comes from African elephants, but some small quantities come from Ceylon and India. African tusks are most valuable and run up to 180 pounds in weight. It is said that the 15,000 cwt. of ivory imported into Europe means a sacrifice of 400,000 elephants, though there is little



A SECTION OF THE IVORY FLOOR AT THE LONDON DOCKS.

seriously in recent years that to ascertain definitely if the pearling grounds are really becoming exhausted to such a degree as make pearling unproductive two experts were sent out by the Secretary of State in the early part of last year to investigate the pearl banks of the islands and to study the life history of the Mergui pearl oysters. The experts have not yet sent in their report, but there is reported reason to believe the banks are becoming exhausted and are in need of considerable rest. Shells are now more difficult to obtain and are less numerous than formerly.

"It was at one time proposed to close the pearling grounds, but the native pearl-ers were unanimous in opposing any such step. They declared that the productiveness of the banks has not appreciably diminished and the fact that the shortage in the supply obtained recently was entirely due to the class of divers having deteriorated. It is admitted that there is some truth in this argument, but all the pearling leases are owned by natives, who naturally are in favor of open banks. Formerly Australian pearl-ers worked there, but they left in 1900, owing to the diminution in the supply of the shell, on which they depended for their profits rather than on the pearls. The only European pearl-ers whose advice is now available, though they have abandoned pearling in favor of tin mining, are in favor of closing the fisheries.



A VIEW SHOWING TWO GREAT TUSKS FROM UGANDA, EACH 10 FEET IN LENGTH, WEIGHING 140 POUNDS, AND VALUED AT \$1,500.

off the coast of Tavoy, but the application was suspended pending the result of the investigation of the two experts sent out by the Secretary of State of Burma to the pearl banks.

doubt but that a large part comes from animals long since dead.

Smith Bros., Elkins, W. Va., recently sustained a loss of \$2,500 by fire.

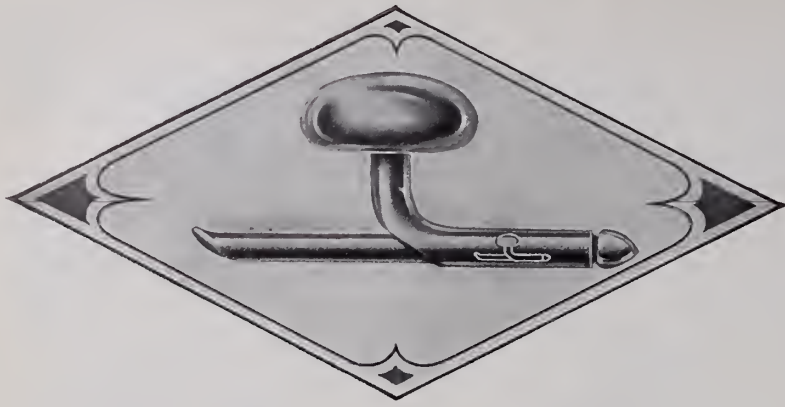

THE COAT SHIRT

is coming more into use each year. If you are a progressive retail jeweler, why not have in stock a line of Shirt Studs that not only can be used in the coat shirt, but also in any other style shirt made?

The Larter Shirt Stud fills all requirements and has our guarantee stamped on the barrel of each in the form of a Trade-Mark that there is no better shirt stud made.

Over 500 patterns in 18K. and 14K. gold and 10K. gold and 14K. gold filled. These last two lines to be had through progressive jobbers.

LARTER & SONS

21-23 Maiden Lane, New York, N. Y.

TRADE-MARK



REGISTERED IN U. S. PATENT OFFICE

Silver Wreath Presented by Swedish Americans to Be Placed on the Bier of the Late King Oscar.

A FITTING tribute of the esteem in which the Swedish Americans of New York hold the memory of the late King Oscar II., who died Dec. 8, 1907, is shown in a silver wreath, which is to be placed on the bier of the late king. The tribute is illustrated on the front cover.

The wreath was purchased by popular subscription, which was raised through the Swedish newspaper *Nordstjernan*. It is of oxidized silver and formed to represent the olive branch, thus denoting peace. The olives are gilt in green gold, and the royal coat-of-arms and the initial O II. in rose gilt. On either side of the coat-of-arms are the flags of the United States and Sweden, both enameled in proper colors. The inscription on the ribbon in Swedish reads, "To the Honored King's memory from the Swedes of New York." The dates "21st Jan., 1829, 8th Dec., 1907," are in raised letters.

King Oscar II. ascended the throne of Sweden Sept. 18, 1872, and reigned 35 years. He was a favorite with his people. Those who have come to New York send the wreath as a fitting tribute to his memory.

German Investigators Report But Little Practical Success in the Making of Artificial Precious Stones.

OUR Consul at Bamberg, William Bardel, advises that about 40 artificial precious stones were recently submitted to the Museum of Natural History at Berlin by an association which claimed to have made these stones, based on the process which recently created so much attention.

Several official experts, among whom was the professor having knowledge of gems at the Museum of Natural History, two practical experts, and the chief master of the gold and silver smiths' guild of Germany were requested to make a careful examination of the merits of the "so-called" new discoveries. The report submitted by the committee of experts reads as follows:

"Of the variety of stones we examine we were favorably impressed only by the artificial rubies. Among these were some of great beauty and worthy of consideration. The white sapphires were of no account at all; they appeared dull and washed out. Well imitated were the yellow precious stones; they really resembled the topaz very closely; but this invention carries with it only very little value, since the real topaz is found in such large quantities that they sell at from 2 to three marks (47.6 to 71.4 cents) a gramme. Therefore it would seem of little importance to imitate such common stones. Of all the stones we examined, we can only call the artificial rubies a direct success; but the imitation of this latter species of precious stones is no new invention. We therefore declare that there is nothing new or sensational in the claimed invention."

Consul Bardel, who submits the report is himself an old jeweler, and has been well known in this country for years, having been a manufacturer in New York

REIGNING PARIS FASHIONS.

JEWELRY NOVELTIES SEEN IN FRANCE'S CAPITAL

PARIS, March 17.—Even exhibitions devoted to the display of mechanical inventions have in Paris an artistic side. The recent exposition at the Automobile Club not only included pictures and statuary, but porcelain and jewelry as well. There were exquisite little *articles de vertu* in bronze and ivory, with Saxe and Sèvres plaques. The high-art products in precious metals were delightful surprises. Juno and Harmony, by Mr. Lemaire, were veritable *chefs d'œuvre*. The former was composed of green jade, rose crystal, labrador, agate, red jasper and white quartz, the latter being used for the flesh tints, while the other tones were utilized for draperies. These conceptions were daring, yet harmonious, the different stones of which they were composed expressing the ideas of the artist with wonderful fidelity. The figure of Harmony is of white quartz, lapis, silex and jasper.

George Fouquet contributed a glass case filled with beautiful and magnificent efforts of the goldsmith's art, laces made of precious stones and of remarkable execution. Mr. Aucoc, the well-known jeweler of the Rue de la Paix, sent an interesting reproduction in marble of the *aéronautique* trophy and a pair of large vases of the traditional blue and white china of the Celestial Empire mounted in silver and silver gilt and most wonderfully *ciselé*.

There were a few of Falize's artistic creations in the shape of bonbon boxes which were greatly admired, and being expressed in different colored enamels and gold. Mr. Rozet exhibited jewels in gold and enamel, while Mr. Vever showed a lovely lamp shade in glass of different colors.

The variety of charms for the *sautoir*, the bracelet or the watch chain is bewildering, and great thought has been expended in their production. Although the pig is far from a romantic animal, Parisians are wearing a tiny gold *porceau* on their watch chains. Perhaps it is a reminiscence of the Gingerbread Fair, when pigs of this delectable dainty are bought by callow youths and presented to their sweethearts. While the edible variety was wont to make a sudden disappearance, the pig of metal is longer lived and more decorative. The elephant, the barnyard cock, the rabbit, the duck and the horse are all made to do duty as mascots.

Very pretty are small hearts cut out of matrix opal almost as blue as a sapphire, and which dangle from the slender chain bracelet. The heart may mean a great deal or nothing, but it is always liked because of its sentimental suggestions.

However, gold and silver are not the only mediums of expression. New Zealand lucky stone, rose and white quartz, amazonite, with ivory and jade, are all carved into miniature semblances of animals. The ivory elephant with a golden saddle is very fashionable.

There is a fancy for wearing the prisoner's ball and chain, the chain taking the form of a heavy gold linked bracelet while the ball is of turquoise or opal matrix, amethyst in clouded hues, quartz of as

ephemeral a pink as a rose petal, or amazonite as green as a willow leaf. With such richness of material one is not amazed to find that the ball and chain bracelet is a much coveted ornament for the arm of beauty.

Jewelers will no doubt be glad to learn that the alarm in regard to the long sleeve is well-nigh baseless, for although long and transparent sleeves are worn, the majority of women insist upon the short or semi-long sleeve, which affords such possibilities for the display of elegant bracelets. Even the long, tight sleeve of transparent fabric does not interfere with the wearing of the bracelet, which can be easily clasped over the filmy fabric. I have noticed an extensive gold and enamel bracelet used to hold the long glove in its place, and which had subscribed to the popular craze for the watch bracelet, doing double duty as a time-keeper and as a clasp to keep the glove tidy on the arm.

Watches no bigger than a dime and with enamel or gold faces are enclosed in cases of faceted crystal or enamel. They are worn either on the *sautoir* or dangling from the bracelet. The tiny finger watch is novel, but is probably to have only the short life of a fad, as by a careless movement of the hand it is ruined past repair. The jeweled and enameled ball watches are again worn.

Seven or nine rings of thread-like proportions are set thickly with tiny baroque pearls, making a pretty ornament for a debutant's finger. Silver serpent rings encrusted with tiny brilliants are worn by gentlemen.

Narrow velvet in lieu of a chain is passed about the neck in lengths about 12 inches, joined by victors' wreaths in gold or silver welded on to a bar, which in turn is clamped to the velvet. The fan design, after a long absence, is again worn as a brooch. A tiny half-open gold fan in pierced work, the outer stick encrusted with diamonds, is a favorite ornament.

A truly regal *parure* was seen at Boucheron's. It might have been a relic of Marie de Medici, for it was in the shape of the wide flaring collar called by the name of that queen, and rather more suited to the rather crude ideas of medieval ages than to those of modern times. It consisted of a series of short curled ostrich plumes expressed in diamonds, the airiness of the feather admirably reproduced, the stems being of rubies. The jeweled plumage at the back was at least a hand's length wide, lightly decreasing in size as they reached the bust. They were attached to a ruby and diamond ribbon, which was tied in front and finished with begemmed pendants. The great collar terminated in an intricate ornamentation of sprays of flowers which descended almost to the waist, and were fastened to the bodice. It is difficult to imagine on what occasions such a magnificent ornament could be worn. It would be impossible for a *decolleté* corsage, and quite out of place on a high-necked gown. However, it might look well on a rich velvet robe cut in V-shape, and which might provide a proper relief for this superb piece of jewelry.

More modest was a pendant most delicately worked, the design being a maiden-hair fern in diamonds. A beautiful dog

collar was a departure from the conventional rows of pearls clasped with a central plaque. Here again was the feather *motif*, but the design consisted of a peacock's plume in diamonds light and graceful, the iridescent eye being expressed in translucent enamels.

Amethysts are very fashionable, and a necklace which looked as if it might be a replica of an ancient design showed square-shaped stones of a velvety purple rimmed with small brilliants. Diamond loops descended low on the bust, each one finished with a similar pendant.

Savoring of a religious reliquary are pendants, the design being a virgin's head in raised and beaten gold on an enameled background. These pendants are quite large and savor more of the shrine than the ballroom.

Much adornment is expended on the lorgnette and the opera glass. For the former tortoise shell, generally amber colored, is again in favor. An exquisite design showed a careless bunch of forget-me-nots in turquoise with diamond leaves. Splendid opera glasses show several rows of diamonds or other gems encircling the lenses. Other lorgnettes are thickly encrusted in a checker-board pattern, or are ornamented with great bosses of opal or turquoise matrix.

COUNTESS DE MONTAIGU.

A Unique Photograph.

THE order for the handsome punch set presented by the City of Paducah, Ky., to the United States gunboat *Paducah*, which was illustrated in the issue of Feb.



SON OF J. L. WOLFF IN PUNCH BOWL OF THE "PADUCAH'S" SILVER SERVICE.

19, was awarded to J. L. Wolff, Paducah, Ky. While the previous illustration appearing in these columns gave a general idea of the punch bowl, there was nothing in the picture that would suggest its size in the way indicated by the accompanying photograph, which was made of Mr. Wolff's little son seated in the punch bowl.

The photograph in question is very popular among the friends of the jeweler.

LOUIS KAHN

MOSES KAHN

SAMUEL H. LEVY

L. & M. Kahn & Co.

Importers and Cutters of

DIAMONDS

170 Broadway, cor. Maiden Lane, New York

AMSTERDAM: 2 TULP STRAAT

CUTTING WORKS: 29 GOLD STREET

Arnstein Bros. & Co.

Importers and Cutters of

DIAMONDS

65 Nassau Street

New York

LONDON: Audrey House, Ely Place

AMSTERDAM: 6 Tulp Straat

ALBERT LORSCH

N. Y. Telephone Call, 2161-2 John

ALFRED KROWER

ALBERT LORSCH & CO.

LORSCH BUILDING, 37 and 39 MAIDEN LANE, NEW YORK

131 Washington Street, Providence, R. I.

Rose Diamonds

Edward Boeck, Missing Diamond Broker, Accused of Larceny Arrested in San Francisco.

J. Edward Boeck, formerly a diamond broker and dealer in curios and art objects, 170 Broadway, New York, who fled from New York, May 10, 1907, when he learned that he had been indicted for stealing about \$50,000 worth of jewelry from local dealers, was arrested, last Wednesday, in San Francisco, after Pinkerton detectives had trailed him over parts of Europe and Asia. Word of his arrest reached New York City from Chief of Police Biggy, of San Francisco, and Inspector McCafferty, of the New York department, immediately notified him to hold Boeck. According to the report received from San Francisco, it ap-



EDWARD BOECK, MISSING DIAMOND BROKER, ARRESTED IN SAN FRANCISCO.

pears that Boeck was seen coming out of a saloon on McAllister St. by a detective, who recognized him from a printed picture in a circular sent out by the Pinkerton Bureau. It is reported that he first denied his identity, but when taken to headquarters and confronted with the facts, he admitted his identity. It is reported that since Boeck left New York he has been working as a jewelry salesman in China much of the time and that he expected to return to that country soon.

It will be recalled that among those who have claims against the prisoner are: Ludwig Nissen & Co., A. H. Smith & Co., Edwin W. Dayton and Marsellus, Pitt & Co., and that he obtained the articles he is accused of taking, through Dr. Dayton, whose standing in the trade was of such a nature that the big dealers allowed him to have on memorandum large quantities of pearls and other articles worth a large amount of money. Two indictments were returned by the Grand Jury of New York County against Boeck.

Boeck's career, as published at the time of his disappearance, reads like a modern book of fiction. His father was a Polish

nobleman, who fled because of political troubles in his country to Shanghai, China, where he married a member of the American Colony, and there the future diamond broker was born. Subsequently the father came to the United States, where he established a polytechnic institution in New York. The family lived in Philadelphia up to the time of the elder Mr. Boeck's death.

The diamond broker started out as a car tracer with the Philadelphia & Reading Railroad. Later he went to Shanghai to take charge of a warehouse for the American Development Co., but the Boxer troubles interfered with the success of the enterprise, and it is said that he took part in the looting of one or more of the Chinese palaces; at any rate, he succeeded in sending to the United States a large quantity of valuable Chinese porcelain, miniature jewelry and precious stones.

In returning to the United States, he came in the suite of Prince Pu-Lun, who had been secretary to the Chinese Emperor, and who came here to attend the St. Louis Exposition. After his return, Boeck claimed authority from Chinese interests to purchase copper in large quantities, and it was through this that he made the acquaintance of the Guggenheims, and of other wealthy people.

His sudden disappearance caused considerable comment in the jewelry trade in New York, and was a direct cause of the failure of Edwin W. Dayton, to whom he was deeply indebted. At the time of his disappearance, all kinds of stories relative to his connections with the Chinese government and his power therein, were aired in the daily papers.

As an echo of the doings of Boeck, it is of interest to note that Deputy Sheriff Porges at New York on the same day that he was captured, sold out his right to title of the interest in 40 small porcelain vases, teakwood stands, china cups and other articles which were seized by attachment on May 27 last, and which have since been in a storage warehouse. The sale realized \$175.

The Jewelers Protective Union have been trying to locate Boeck ever since his disappearance, and working through Pinkerton detectives, has at last succeeded in running him down.

Detectives started Thursday for San Francisco from New York to bring Boeck back to that city. It is reported that Boeck is willing to come to New York without extradition papers.

Consolidated Jewelry Firms of Cleburne, Tex., Make a General Assignment.

CLEBURNE, Tex., March 18.—The consolidated firms of Thomas Doe & Co. and the Lawrence Jewelry Co. made an assignment March 10 for the benefit of creditors. The assets of the firm are listed at \$26,000, and the liabilities scheduled amount to about \$21,000.

The Lawrence Jewelry Co., which was consolidated with the former firm about 60 days ago, was the oldest business firm in this city, with one exception. Thomas Lawrence started business in 1873. He died in 1899 and the business was continued by his widow until the fall of the same year, when it was incorporated.

Exports of Jewelry, Clocks, Watches, Silverware and Kindred Lines from the Port of New York.

WASHINGTON, D. C., March 18, 1908.—The following were the exports of jewelry, silverware, optical goods, clocks, watches and kindred lines from the Port of New York for the week just ended:

- Auckland: 1 case watches, \$110; 41 cases clocks, \$1,026; 126 cases clocks, \$2,660.
- Ashanti: 22 cases clocks, \$197.
- Aden: 6 cases clocks, \$134.
- Bremen: 1 case plated ware, \$175; 3 cases watches, \$7,195.
- Bombay: 59 cases clocks, \$1,060.
- Bocas Del Toro: 8 cases clocks, \$1,170.
- Brussels: 1 case jewelry, \$100.
- Buenos Ayres: 15 cases clocks, \$866; 1 case watches, \$439; 3 cases optical goods, \$1,421; 38 cases plated ware, \$3,841; 2 cases silverware, \$2,000; 1 case watches, \$392; 8 cases clocks, \$2,569; 1 case jewelry, \$5,000; 1 case jewelry, \$271; 13 cases plated ware, \$1,027.
- Calcutta: 126 cases clocks, \$3,029.
- Christiana: 1 case plated ware, \$185; 5 cases clocks, \$261.
- Callao: 2 cases jewelry, \$841.
- Colon: 12 cases clocks, \$439.
- Copenhagen: 7 cases clocks, \$101.
- Glasgow: 50 cases clocks, \$2,200.
- Hamburg: 1 case plated ware, \$500; 1 case plated ware, \$325; 3 cases optical goods, \$334; 33 cases jewelry, \$586; 59 cases clocks, \$2,473.
- Havre: 35 cases clocks, \$3,786; 1 case silverware, \$200; 3 cases jewelry, \$380; 1 case optical goods, \$376.
- Havana: 35 cases clocks, \$826; 2 cases optical goods, \$131; 16 cases clocks, \$148.
- Iquitos: 1 case jewelry, \$270.
- Kingston: 7 cases clocks, \$104; 4 cases watches, \$575; 11 cases clocks, \$157.
- Liverpool: 31 cases clocks, \$247; 3 cases watch material, \$1,500; 2 cases jewelry, \$950; 118 cases clocks, \$2,782.
- London: 5 cases watches, \$724; 122 cases clocks, \$4,895; 1 case jewelry, \$240; 11 cases optical goods, \$4,441; 1 case plated ware, \$336; 1 case optical goods, \$335; 3 cases stereoscopes, \$100.
- Soerabaya: 15 cases clocks, \$246.
- Manila: 1 case optical goods, \$50.
- Manaos: 3 cases plated ware, \$490; 21 cases clocks, \$358; 1 case jewelry, \$169.
- Monbassa: 12 cases clocks, \$144.
- Montevideo: 10 cases clocks, \$421.
- Melbourne: 3 cases silverware, \$202; 2 cases optical goods, \$194; 10 cases watches, \$1,406; 41 cases clocks, \$564.
- Nassau: 18 cases clocks, \$242.
- Pernamhuco: 13 cases clocks, \$415; 6 cases clocks, \$2,696; 3 cases jewelry, \$380.
- Puerto Plata: 4 cases jewelry, \$160.
- Rome: 1 case jewelry and effects, \$100.
- Savanilla: 1 case jewelry, \$283; 8 cases clocks, \$333.
- Santos: 195 cases clocks, \$2,764.
- Singapore: 4 cases optical goods, \$187.
- Southampton: 21 cases watches, \$3,508; 1 case optical goods, \$332.
- Sydney: 1 case optical goods, \$187; 35 cases clocks, \$1,049; 12 cases scopes and views, \$480; 8 cases plated ware, \$469; 102 cases clocks, \$2,504; 1 case optical goods, \$191; 2 cases watches, \$264.
- Vera Cruz: 8 cases clocks, \$103.
- Valparaiso: 3 cases plated ware, \$200.

Paris Notes.

PARIS, March 10.—The month of February passed without any remarkable changes being noted in the pearl market, business being very quiet throughout. The Parisian spirit of speculation has not shown any activity, in pearls at least, and only very small transactions have been noted from time to time. The good news as to the harvest of the Argentine Republic, which came here during the latter part of the month, influenced the market favorably to some extent, but at the present time sales are quiet. The declaration of the Diamond Syndicate of the De Beers and Premier mines that the prices will be maintained made a satisfactory impression upon the trade here.

G. K.

REGISTERED



TRADE-MARK

RINGS

REGISTERED



TRADE-MARK

RINGS are always in demand, and are always salable, provided you have the right kind to sell. We have—

RINGS of every description: signet rings, diamond rings, fancy rings, rings of every style and combination of stones.

RINGS that satisfy the most critical and appeal to every taste and fancy.

RINGS You can sell. *Write us or wire us any time. We are always ready for your order.*

HAYDEN W. WHEELER & CO., Importers

AMSTERDAM, 2 Tulp Straat

2 Maiden Lane, NEW YORK, N. Y.

Phone, 7365 Cortlandt

LONDON, 50 Holborn Viaduct

EDUARD VAN DAM

CUTTER OF

DIAMONDS

— CUTTING SHOPS: —

ANTWERP

41 Rue de la Province (Sud.)

CABLE ADDRESS, MADNAV

NEW YORK437-439 Fifth Ave.
Cor. 39th St. Knabe Bldg.TELEPHONE, 5879 38TH ST.
CABLE ADDRESS, DEVRIVAN**AMSTERDAM**

55 Ruysdaelstraat

CABLE ADDRESS, MADNAV

LONDON OFFICE, 22 Holborn Viaduct

AMSTERDAM

2 Tulpstraat

LONDON

40 Holborn Viaduct

OPPENHEIMER BROS. & VEITH.

CUTTERS OF DIAMONDS.

Cutting Works
43-45-47 John StreetNEW YORK
65 Nassau Street

RUDOLPH NOEL

PHILIP NOEL

RUDOLPH NOEL & CO.

IMPORTERS AND CUTTERS OF DIAMONDS

2 Tulp Straat, AMSTERDAM

37-39 Maiden Lane, NEW YORK

Kaplan & Co. Offer Reward for Arrest of Zucker, Their Missing Salesman.

S. Kaplan & Co., 51 Maiden Lane, New York, are offering a reward of \$300 for the arrest of Samuel Zucker, or Solomon Zucker, the salesman who was in the employ of the firm a short time, and who left their offices on Feb. 25, with samples valued at \$4,162, for which he has not since accounted. It was Zucker's custom to report each night, but when he did not do so, his employers became suspicious and succeeded in tracing the missing man to Philadelphia and Atlantic City, where they lost track of him.

Mr. Zucker is described as being 38 years of age, 5 feet 10 inches in height, weight 150 pounds, with black hair and eyes, heavy black mustache and beard. A warrant was served out for him some time ago, and



ZUCKER, FOR WHOSE ARREST A REWARD IS OFFERED.

Central office detectives are now working on the case. He was born in Austria.

Following is a list of the missing property: One diamond ring, 1 13/16 kt.; platinum brooch, 70 diamonds, 3 11/16 kt.; platinum brooch, 78 diamonds, 1 3/4 kt.; platinum brooch, 76 diamonds, 1 7/8 kt.; brooch, green and white, 29 diamonds, 1 1/2 kt.; four brooches, pearls and 1 diamond, 1 1/2, 1/8, 1/16, 1 1/16 kt.; princess ring, 3 diamonds, 1 1/4 kt.; fancy platinum ring, 10 diamonds, 1 9/16 kt.; square platinum ring, 21 diamonds, 27/32 kt.; ring, diamond, 35/64 kt.; one sapphire, 3/4 kt. and 1 ruby; 12 diamond rings, one diamond each, weighing 1 7/32, 5/16, 13/64, 5/32, 1 1/2, 1/4, 1/4, 7/32, 1/4, 15/32, 1/4 kt.; four rings, three diamonds in each, weighing 7/32, 25/32, 1/4, 7/8 kt.; ring with five diamonds, 5/8 kt.; ring with two diamonds, 3/64 kt.; cluster ring, 18 diamonds, 11/32 kt.; four cluster rings, one diamond each, 17/64, 3/32, 5/16, 9/32 kt.; five lockets, one with 31 diamonds, 13/16; one with six, 35/64; one with 1 7/64; two with three each, one weighing 1/16, and other 7/64 kt.; 1 lockets, two with one diamond each, weighing 1/8; one with five, weighing 1/4; one with five, 9/32; one, 7/32; two, 1/16; one, 3/32; one with three diamonds, 7/32;

one with 10, weighing 1/2 kt. Seven bracelets, one with one diamond, 3/16; two sapphires, 1/2, one with two diamonds, 1/4; one sapphire, 1/4; one with three diamonds, 5/16; two emeralds, one, two diamonds, 1/8; three rubies, 3/16; one with two diamonds, 3/16; one emerald, 5/16; one with five diamonds, 5/8; one with five diamonds, 1/4 kt.; 11 bracelets. Four parcels, one with 52 loose diamonds, 4 15/32; one with five diamonds, 2 3/32; one with 18 diamonds, 3/4; one with 38 diamonds, 2 1/2; two horseshoe scarf pins, 15 diamonds in each, each pin 1 3/8 kt.; scarf pin, four diamonds, 11/64 kt.; one covered face watch repeater; one sapphire, 5 9/16 kt.; one locket, four diamonds, weight 9/64 kt.

Bids Received and Contracts Awarded by Government Departments to Supply Various Articles.

WASHINGTON, D. C., March 18.—The War Department is inviting proposals until April 15, for the supplies for the fiscal year ending June 30, 1909, and among the items called for are the following: One dozen silver-plated water pitchers, five dozen thermometers, medium.

WASHINGTON, D. C., March 18.—The International Silver Co., Meriden, Conn., has been awarded the contract for supplying the Brooklyn Navy Yard with a large quantity of hollow silver-plated ware, for which bids were opened on March 3, at \$6,158.55; also for flat silver-plated dessert knives, forks and coffee spoons, opened on the same date at \$935.40.

WASHINGTON, D. C., March 19.—The Bureau of Supplies and Accounts, Navy Department, has received a bid of \$1,884 for a quantity of silver plated ware for the Brooklyn Yard from the International Silver Co., of Meriden, Conn., as usual, the only bidder.

WASHINGTON, D. C., March 20.—The Bureau of Supplies and Accounts is calling for proposals until March 31 for the following supplies for the Annapolis Navy Yard: One Leeds & Northrup Co.'s outfit of resistance thermometers; eight standard thermometers, graduated, to register from 32° to 212° F., each thermometer to be in a felt-lined nickel-plated brass case; four thermometers, 9 inches, graduated from 0° to 120° F., in half degrees, to be packed same as above; 24 thermometers, 15 inches, graduated from 100° to 450° F., in half degrees; four thermometers, 18 inches, graduated from 200° to 600° F.; five thermometers, 18 inches, graduated from 200° to 800° F.

Death of Samuel Thomas.

TABOR, Ia., March 18.—In the death of Samuel M. Thomas, which occurred Thursday last, Tabor lost the second of its jewelers within a month, A. T. West having died Feb. 13. Mr. Thomas died from a blood clot on the brain, with which he was attacked some time ago, and had remained in a stupor over a fortnight. His death is deeply regretted, as he was well known and popular throughout this section of the State.

The deceased began business in 1888, and though he quit the jewelry trade for a short time he returned to it in 1903 and continued

here, building up an excellent trade. He is survived by a widow and two grown sons, and the elder of the latter will carry on the business.

Milwaukee Jewelers Petition Common Council for Redress for Recent Destruction of Street Clocks.

MILWAUKEE, Wis., March 19.—A citizens' petition praying for an investigation of the wrecking of jewelers' street clocks, and a claim for \$530 for the clock of W. & E. Schmidt, Inc., are the latest developments in the fight between the Milwaukee jewelers and Mayor Sherburn M. Becker and his subordinates.

The citizens' petition reads:

Whereas, The street clocks of the jewelers of Milwaukee were removed in the night time from March 4 to 5, by the fire department, acting under the instructions of Mayor S. M. Becker and chief of the fire department, Thomas A. Clancy; and,

Whereas, In many instances these clocks, the private property of citizens of Milwaukee, were willfully destroyed by such purported removal, and were let lay on the sidewalk of the city, we the undersigned, citizens and qualified electors of the city of Milwaukee, respectfully petition the common council that said matter be investigated and that the proper authorities proceed immediately against any and all persons guilty of the destruction of private property of citizens.

The claim of W. & E. Schmidt, Inc., is made in the following language:

Whereas, The undersigned was the owner of one certain street clock of the value of \$530, which said clock was, until March 5, stationed in front of the undersigned's place of business, 308 3d St., and,

Whereas, Said clock was torn down and totally destroyed at 3 A. M. by order of the Mayor of Milwaukee, S. M. Becker, and was later on, to wit: On March 7, taken possession of by said city of Milwaukee.

Therefore, The undersigned respectfully petition your honorable body that said city of Milwaukee pay the undersigned the value of said stock, to wit, \$530.

N. Steen, a Jeweler of Albert Lea, Minn., Commits Suicide by Hanging.

ALBERT LEA, Minn., March 18.—The news that N. Steen, a local jeweler, had committed suicide came as a great shock to his friends in the city, most of whom knew that he had been in ill health, but had no idea that his physical condition would lead him to commit such an act. Mr. Steen hanged himself Monday morning last, and the body was not discovered until the afternoon.

The deceased was 45 years old and was a partner in the jewelry firm of Bessesen & Steen, who began business here in 1887 and had been very successful. He was highly regarded by the jewelry trade and all who knew him either personally or in a business way. The fact that he had learned that his physical condition was such that there was no chance for recovery is believed to have prompted his act.

The building occupied by R. F. Church as a jewelry store, Albion, Mich., was destroyed, March 9, during a flood. The building was owned by Mr. Church.

The wife of C. O. Beiderman, Oneonta, N. Y., died March 20st, aged 57 years. The funeral services were held at Camden Monday afternoon. Mr. Beiderman has the deep sympathy of many friends in the trade in his bereavement.

Cameos = Scarabs = Carbuncles

Notwithstanding the difficulty generally experienced at present in supplying the sudden demand for these goods, we have succeeded, thanks to our firmly established connections with the stone centers of Europe, in making arrangements for the uninterrupted supply of them and are, therefore, fully prepared to fill all orders for these articles with the greatest possible dispatch.

CAMEOS — ONYX, PINK and BROWN SHELL, and CORAL

SCARABS and CARBUNCLES } RED and BROWN SARD, BLOODSTONE, MOSS AGATE, GREEN AGATE, NEW ZEALAND and CHINESE JADE, AMAZONITE, TIGER EYE, CORAL and TURQUOISE MATRIX

In all regular and special shapes and sizes

J. Heller & Son

Importers of Precious and Imitation Stones
68 NASSAU STREET, NEW YORK

PARIS
39 Rue de Chateaudun

PROVIDENCE
212 Union Street

IDAR
14 Hauptstrasse

ORDER

DIAMONDS

ON MEMORANDUM FROM

ALFRED H. SMITH & CO.

London,
8 Holborn Viaduct.

170 BROADWAY, NEW YORK.
Corner Maiden Lane.
Also 475 FIFTH AVENUE.

Chicago,
103 State Street.

EDELWEISS
BROOCHES

CROSSMAN
COMPANY



\$10 DOLLARS
UP

3 Maiden Lane
NEW YORK

GARREAU & GRISEL
68 & 70 Nassau St., New York
LAPIDARIES. PRECIOUS STONES
EMS in Unique Cutting

THE CROWN PATENT SAFETY GUARD



For Scarf Pins, Studs and Loops. The most practical and adjustable one invented. Price, \$1.50 per doz. For sale by all wholesale jewelers and material houses. Same by mail, 25c; in 10k. gold, \$1.00; 14k., \$1.25. M. CROH, Maker and Inventor, 48 and 50 Maiden Lane, N. Y.

A. ROSEMAN, 9-11-13 Maiden Lane, New York

IMPORTER OF

DIAMONDS

Maker of Diamond Jewelry



TRADE-MARK.

Established 1872

HEADQUARTERS FOR
**AMERICAN
WATCHES**

PRACTICAL COURSE IN ADJUSTING

Published Price, \$3.50.

Special Reduced Price, \$1.50, Postpaid.

The Jewelers' Circular Pub. Co., 11 John St., N. Y.

Association Notes.

What is Being Done by the National and State Organizations of the Retail Jewelers.

The next annual meeting of the North Carolina Retail Jewelers will be held in Raleigh, N. C., May 14, 1908. President Fruat of this association has sent a circular letter to all members of the trade in North Carolina, telling them to get together and do something to remedy the many abuses to which they are subjected, by joining the association and working together. Jewelers, whether members of the association or not, are invited to the annual meeting in Raleigh.

* * *

President A. E. Barker of the Minnesota Retail Jewelers' Association has announced the appointment of the following committees 1908:

Assaying—John Rentz, Minneapolis; C. H. Hutter, St. Paul; J. D. Lifquist, Henning.
Grievance—D. C. Spaulding, Wabasha; Jas. White, Minneapolis; Chas. Altenberg, Ironmont; J. D. Bodfors, Minneapolis; F. Logan, Royalton.

Employment—Julius Anderson, Mora; Jos. Gaskell, St. Paul; Jon. Rosendahl, Appleton.

Finance—W. G. Gould, Glencoe; E. L. Wentworth, Kasson; Chas. Olson, Minneapolis.

Membership—Geo. H. Lang, Mankato; L. Williams, Zumbrota; M. C. Weyer, Ribault.

Entertainment—A. E. Paegel, Minneapolis; Emil Geist, St. Paul; R. L. Munns, Minneapolis.

* * *

The following committees have been appointed by President Hurlbut of the American National Retail Jewelers' Association:
Trade Interest—W. F. Kaemper, St. Louis, Mo.; Frank Hannis, York, Nebr.; C. Graul, Sharpsburg, Pa.

Assaying—J. M. Nabstedt, Davenport; C. E. Tillson, Carrington, N. Dak.; Max Robinson, Birmingham, Ala.

Legislature—H. G. Nichols, Mitchell, S. Dak.; Stephen Thomas, Charlestown, S. C.; M. Quarles, Clarksville, Tenn.

Membership—J. R. Stebbins, Ashtabula, O.; A. E. Paegel, Minneapolis; Minn.; J. Rowe, Argus, Ind.

Deceased Members—E. B. Lewis, San Francisco, Cal.; Geo. H. Ford, New Haven, Conn.; F. C. Boasen, Oklahoma City, Okla.

Transportation—C. W. Slagbaugh, Taylorville, Ill.; H. E. Adams, Tampa, Fla.; McKay, West Branch, Mich.

Credentials—T. A. Westmyer, Wheeling, W. Va.; E. A. Short, Prescott, Ark.; L. C. Sienenschmidt, Newport, Ky.

* * *

Steps are being taken and meetings will be called at an early date, for the organization of retail jewelers' associations in the States of Virginia and Illinois, besides the work of resurrecting several associations that have failed to make good.

* * *

A meeting of the executive committee of the Missouri Society of Retail Jewelers was called for Monday last, March 23, at the

Baltimore Hotel in Kansas City, 9 A. M. to determine the time and place of the annual meeting and also to consider other matters of consequence to the society. This committee is composed of R. D. Worrell, Mexico, president; Claud Wheeler, Columbia, first vice-president; J. S. Huey, Excelsior Springs, second vice-president; Claud E. Range, Trenton, secretary-treasurer; Charles Bard, Sedalia; H. L. Raines, Maryville; Adam A. Hafner, De Soto; F. W. Baier, St. Louis, and G. E. Read, of Lebanon, Mo. A meeting of the executive committee of the Missouri Association of Opticians was called for same time, place and purpose.

Friends Pay Last Tribute to the Late Charles Adler.

A large number of the most prominent men in the diamond trade gathered Tuesday of last week at the residence of the late Charles Adler, 114 W. 77th St., New York, to pay their last respects to one of the oldest and most highly esteemed members of the industry of this country. Mr. Adler died Saturday, March 14, as the result of a stroke of apoplexy.

Charles Adler was born Nov. 11, 1825, at Markelsheim, Württemberg, Germany, and came to this country in 1844. He settled at Syracuse and some time afterward went to Florida, where he engaged in the cotton and tobacco business until after the Civil War. Then he returned to New York City and went into the diamond business with Louis Strasburger, under the firm style of L. Strasburger & Co., at 11 Maiden Lane, where he remained in business until his retirement, Jan. 1, 1888.

Deceased is spoken of by men who knew him during his business career, as a man who reflected honor upon his trade by his upright, straightforward and sterling qualities, and who believed in helping his fellowmen wherever possible. He was interested in several charitable organizations.

Mr. Adler married Caroline Lightstone, who, together with three sons and one daughter, Mrs. Max Baer, survive him. His sons are in business at 527 Fifth Ave., under the style of Charles Adler's Sons.

Involuntary Bankruptcy Petition Filed Against H. Anzelewitz & Co., New York.

A petition in involuntary bankruptcy was filed last Friday in the United States District Court at New York against A. Anzelewitz & Co., a corporation doing a wholesale jewelry business at 154 Canal St., by Julius J. Lurie, for \$790 and Alter Shapiro, for \$375 for money loaned to the alleged bankrupt, and by Anzelewitz Bros., \$268 for goods sold and delivered.

The petition alleges that the concern is insolvent and owes debts to the amount of \$1,000 and upwards and that it committed an act in bankruptcy and admitted in writing about March 19, its inability to pay debts and willingness to be adjudged a bankrupt.

The liabilities are \$57,000, and the assets about \$45,000, consisting of stock, estimated at \$40,000, and accounts estimated at \$5,000. The book value of the stock is \$50,000, and of the accounts, \$10,000.

Frederick C. McLaughlin has been ap-

pointed receiver under a bond of \$25,000. The bankruptcy action was precipitated by several creditors to prevent the execution of a judgment obtained by one creditor on a claim of about \$2,000.

Tariff Decisions by General Appraisers on Jewelry, Gems and Kindred Lines.

Decisions by the Board of United States General Appraisers in cases involving duties on jewelry and kindred lines have been announced in the last week as follows:

AGATE ARTICLES.—Protest of the American Express Co., Baese & Co. and Albert Lorsch. Assessment affirmed as to agate articles.

STRUNG BEADS.—Protests of American Bead Co., New York. Opinion by Sharretts, G. A. Assessment affirmed as to strung beads. G. A. 6610 (T. D. 28221) followed.

FOBS OF BONE AND IVORY.—Protest of Morimura Bros., New York. Opinion by Sharretts, G. A. The protest related to fobs classified as jewelry. As claimed by the importers, the Board hold one portion dutiable as manufactures of bone under Par. 449, Tariff Act of 1897, and another portion as manufactures of ivory under Par. 450.

PINS—VINAIGRETTES.—Protest of R. F. Downing & Co., New York. Opinion by Sharretts, G. A. The protest related to pins and vinaigrettes. The pins were held to have been properly classified as jewelry, and, as claimed by the importers, the vinaigrettes were held dutiable as manufactures of metal.

TOY NECKLACES.—Protest of American Bead Co., New York. Opinion by Sharretts, G. A. A portion of the goods (necklaces) were held dutiable as toys as claimed by the importers. G. A. 6658 (T. D. 28391) followed.

TOY ALARM CLOCKS.—Protest of G. W. Sheldon & Co., Chicago. Opinion by Sharretts, G. A. Alarm clocks, about one-half inch in diameter and fitted with a compass, were held dutiable as toys under Par. 418, Tariff Act of 1897, as claimed by the importers.

PINS.—Protests of Albert Lorsch & Co. et al., New York. Opinion by Sharretts, G. A. Protests sustained as to pins. G. A. 6376 (T. D. 27390) followed.

RECONSTRUCTED RUBIES—IMITATION PEARLS.—Protests of Fredericks et al., New York. Opinion by Sharretts, G. A. Protests sustained as to reconstructed rubies and imitation pearls. G. A. 6088 (T. D. 26554), G. A. 6336 (T. D. 27278) and G. A. 6637 (T. D. 28291) followed.

JEWELRY.—Protests of Edson Keith & Co. and protests of G. W. Sheldon & Co., Chicago; protests of E. & J. Bass, protests of W. H. Stiner & Son et al., New York, and protest of Stix, Baer & Fuller Dry Goods Co., St. Louis. Opinions by Sharretts, G. A. These protests were against the assessment of the merchandise as jewelry. Protests overruled.

Over \$500 worth of goods, including about 30 watches, chains, etc., were stolen from the store of Shapiro Bros., Orbisonia, Pa., recently. Two suspects have not been caught as yet. A reward of \$25 has been offered for their apprehension.

An EXHIBITION *of* GEMS ROUGH AND CUT

March 24th to 28th inclusive, at 537 Fifth Ave., N. Y.



THIS exhibit is for the purpose of better acquainting the jewelry trade and the public with our product of Precious and Semi-Precious stones both in the rough and cut. Among the minerals exhibited will be Tourmalines, Chrysoprases and Turquoises from our own mines situated in the state of California. We will show these goods in the process of cleaving, cutting and polishing as well as an exceptionally fine display of Gem Crystals. These gems both in brilliancy and beauty cannot be excelled.

We extend a cordial invitation to the entire trade, and a treat is in store for those who will visit the display. We trust that we shall have the pleasure of greeting you and showing you through the exhibit.

Respectfully,

HIMALAYA MINING CO.

Look Out for These Swindlers Who Are Visiting Jewelers in Western States.

CHICAGO, March 23.—Members of the jewelry trade are warned to look out for jewelry swindlers who are working in the West. A Hebrew couple, the man short and stout, and the woman tall and stately, are working through Iowa and Nebraska. They open a store and represent themselves as in need of money to cover some margins in copper stocks. They show a telegram from their supposed broker to this effect, and say they want a loan on some jewelry and agree to pay 10 per cent. a month for the same. The jewelry they exhibit is very lowly, cluster stuff very cleverly mounted and is usually made up of very poor diamonds.

Sometimes they show a poor chronometer, an imitation of high grade watches. They also show bogus bills for the jewelry, wherein the number of carats is double what the jewelry usually contains. Many jewelers have been swindled in sums up to \$900. Another swindler working the trade represents himself as a stranded solicitor for a wigwag tailoring house. He carries a pocket studded with diamonds, usually a large stone in the center and seven quarter carats around it, and a bracelet with seven carter stones set in it. He also asks for a loan and usually gets \$350 for stuff which can be bought on the market for half that amount.

It is hard to understand why any jeweler should loan money to swindlers like these, when he can buy on time the same quality of goods for half the money from reputable houses, especially as there is a heavy fine provided in most States for people who take pledges without a license to do so.

Continuation of Examination in Bankruptcy Proceedings Against Joseph Brown & Co.

CHICAGO, March 23.—An examination to the affairs of Joseph Brown & Co. was held last Friday. The lawyers interested are trying to find out what became of the cash the firm received before the failure.

Herman G. Briggs, of Briggs & Dodd, testified that his firm had sold between \$3,000 and \$10,000 worth of goods for Brown during December, and of this amount 75 per cent. was paid to Brown. Brown couldn't remember the name of his employe whom he sent to collect the money. He said "anybody might go over and get it."

Adolph Raphael, a lawyer, testified he was willing to give up his practice to become Brown's manager at a salary of \$5,000 a year and 25 per cent. of the gross profits. He said he understood Mr. Brown was a millionaire. He went to work Jan. 15; on Feb. 3 he received \$200 and on Feb. 4 received \$1,000. An order will be asked for requesting Mr. Raphael to return the money.

Geo. A. Jackson, chief clerk of the Continental National Bank, then showed Brown's deposit slips. In December, Brown deposited \$4,380 in currency. In January, \$587, and on February nothing. Brown took the stand and remembered nothing.

Mr. Brown was taken before Referee

Eastman and was instructed to go to his former place of business and see if he could find the missing diamond record book, and also the card index system which acted as a check on the diamond record book. Mr. Brown went to his former place of business with a representative of the American Trust & Savings Bank, but he could not find the diamond records. Before he went, Jacob Ringer, attorney for the receiver, offered to bet Hugo Pain, attorney for Brown, that Brown would not find the diamond records. Mr. Pain did not accept the wager.

Grand Jury Indicts Pittsburg Jeweler on Charge of Creditors Who Brought Bankruptcy Proceedings.

PITTSBURG, Pa., March 21.—Morris Biederman, a South Side jeweler against whom a petition in involuntary bankruptcy was recently filed by some of his creditors, must answer a charge preferred against him by a few of his creditors. It is alleged that he secured some goods for the purpose of defrauding the dealers, but this has been strenuously denied by Biederman. The Grand Jury has found a true bill against him on the charge brought and his case, it is expected, will be tried shortly.

The fact that charges of this nature had been laid against Biederman only developed during the last week, a meeting of his creditors having been held last Thursday in the office of Referee of Bankruptcy William Blair, in the St. Nicholas building. Attorney A. M. Lee, with offices in the same building, has been appointed to look after the interests of the creditors.

Biederman has emphatically denied to those who are bringing criminal action, that he has done anything wrong. It is, however, stated that the charge against him is to be pushed to a final hearing.

Creditors File Bankruptcy Petition at Chicago, Against Max Marcus & Co.

An involuntary petition in bankruptcy has been filed against Max Marcus, doing business as Max Marcus & Co., wholesale jewelers, at 92 State St., who recently sought to compromise with his creditors at 40 cents on the dollar. At that time Mr. Marcus claimed assets of \$9,000 and liabilities of \$12,000.

The creditors who filed the bankruptcy petition and the amounts due them are: Sussfeld, Lorsch & Co., \$3,308; Byron L. Strasburger & Co., \$840, and Hipp. Disdisheim & Bro., \$45.

Max Marcus & Co., which was formerly known as Marcus, Valentine & Co., began business in 1893, handling first watches and optical goods and then jewelry. The partners were Max Marcus and E. M. Valentine. The latter withdrew over a year ago and Mr. Marcus continued the business individually from that time.

Robert G. Nelson & Co., Toledo, O., Go Into Voluntary Bankruptcy.

TOLEDO, O., March 21.—Robert G. Nelson & Co., wholesale jewelers, located at 103 Chamber of Commerce building, have filed a voluntary petition in bankruptcy in the local United States District Court. The

schedules show liabilities listed at \$9,654.24 and assets at \$6,185.08.

Robert G. Nelson & Co. are among the oldest wholesale jewelers in Toledo, the firm having been established more than 20 years ago by Robert Nelson, Sr., the first location being on Summit St. From this place the firm moved to the Chamber of Commerce building, in the rooms at present occupied. After being here for years, the firm moved to the Spitzer Arcade, and about three years ago moved again to the Chamber of Commerce building.

While Mr. Nelson is reticent in discussing his affairs, it is said by other jewelers here that the matter was culminated by the recent financial flurry; further, that Mr. Nelson offered to make a settlement with his creditors but this was not accepted.

Creditors File Bankruptcy Petition Against Henry Welf Co., Cleveland, O., Which Recently Assigned.

CLEVELAND, O., March 21.—Several creditors of the Henry Welf Co., 2067 E. 4th St., which made an assignment March 9, filed an involuntary petition in bankruptcy in Federal Judge Taylor's Court on Tuesday. Attorneys Weed, Miller and Nason represent the following creditors who filed this petition: W. E. Hayward, \$63; L. H. Bronner, \$170; W. L. Gilbert Clock Co., \$180; L. H. Littlefield, \$84; Farrington Mfg. Co., \$30.

An appraisal had already been completed by the assignee and arrangements to dispose of the stock were under way, but it is feared that this latest move will delay distribution of assets considerably.

Importations at the Port of New York.

Weeks Ended March 16, 1907, and March 14, 1908.

China, Glass and Earthen Ware:	1907.	1908.
China	\$86,313	\$43,885
Earthen ware	13,350	3,997
Glass ware	35,725	11,489
Optical glass	216	224
Instruments:		
Musical	18,370	3,600
Optical	14,551	6,963
Philosophical	2,985	345
Jewelry, etc.:		
Jewelry	17,948	32,408
Precious stones	\$04,736	49,381
Watches	27,018	24,180
Metals, etc.:		
Bronzes	1,474	1,326
Cutlery	54,604	32,048
Dutch metal	1,643
Platina	46	10,843
Plated ware
Silverware	4,132	6
Miscellaneous:		
Alabaster ornaments	482
Amber	8,639	12,511
Beads	8,746	839
Clocks	4,243	875
Fans	21,809	2,990
Fancy goods	13,773	4,255
Ivory	34,862	13,120
Ivory, manufactures of	76	125
Marble, manufactures of	1,774	7,021
Statuary	708	2,388

Recent reports show that the Ceylon Pearl Fisheries have declared a dividend of 21 per cent. on ordinary shares, and of 75 per cent. on deferred shares at a recent meeting of the Board of Governors. It is expected that the fisheries will be suspended for a time pending a suspension of the banks.

Chester Billings & Son

1840

Successors to
Kandel, Barmore & Billings

1908

Importers of Diamonds
Other Precious Stones, and
Pearls, Diamond Jewelry

1840, Kandel & Barmore; 1866, Kandel, Barmore & Co.; 1880, Kandel, Barmore & Billings;
1897, Chester Billings & Son

New York, 58 Nassau Street, 29 Maiden Lane
London: 22 Holborn Viaduct, E. C. Paris: 53 Rue de Chateaudun
Amsterdam: 2 Tulp Straat

GEORGE H. HODENPYL.

WALTER N. WALKER.

HODENPYL & WALKER

IMPORTERS OF

DIAMONDS

OTHER PRECIOUS STONES
AND PEARLSMANUFACTURERS OF
FINE DIAMOND JEWELRY

373 FIFTH AVENUE,

NEW YORK

Corner 35th Street

Telephone, 5093 Madison Square

CHAS. F. WOOD & CO.

DIAMONDS

I MAIDEN LANE

NEW YORK

EISENMANN BROS.

IMPORTERS OF

Pearls and Precious Stones

452 Fifth Avenue, New York
cor. 40th St., Knox Building

3 Rue St. Georges, Paris.

Ludwig Nissen & Co.

182 and 184 BROADWAY
NEW YORK

PEARL NECKLACES AND DIAMOND COLLARETTES

Mounted Diamond
Jewelry of Every
description :: ::

Largest assortment
of all kinds of very
fine, fancy and rare
gems, including
Pearls, Diamonds,
Emeralds and
Sapphires :: ::

PARTICULARLY
FANCY COLORED
AND FANCY
SHAPED DIAMONDS

Ludwig Nissen & Co.

182 and 184 BROADWAY
NEW YORK

Aware of This Man With the Automobile Clock. A Reward Offered for His Arrest.

NEW HAVEN, Conn., March 23.—S. Silverthau & Sons, whose establishment was robbed recently of \$900 worth of diamond jewelry, as told in the last issue of THE JEWELERS' CIRCULAR—WEEKLY, in a communication, Monday, stated that the thief stole stock valued at \$100 in a similar manner from J. Kingsberg, of 203 Main St., Springfield, Mass., on Jan. 28 last, and on Feb. 8 obtained from L. Simon, 525 Fulton St., Brooklyn, two rings worth \$500. The same man is supposed to have been the one who stole from Aaron Ball, of Troy, N. Y., \$700 worth of stock. In each case the thief called at the establishment and left a Chelsea automobile clock to be repaired, and not a watch, as previously reported.

The property stolen from S. Silverthau & Sons consists of a pair of diamond earrings weighing 3 carats less 1/16, one of them being perfect, but cut a trifle longer than the other, which was perfectly round; lady's Tiffany ring containing a stone weighing 1 3/8 carats less 1/32, very slightly imperfect in a platinum setting. Scratched to the shank of the ring was the stock number 5274.

The thief is described by Mr. Silverthau as between 28 and 32 years of age, about five feet five inches or five feet eight inches tall, and weighing from 135 to 150 pounds. He had a smooth-shaven face, long sharp nose, brown hair, rather curly, and the nail on the little finger of the right hand is imperfect, caused, as he claimed, by having been caught in the chain of an automobile. At the time he entered the store he wore a gray overcoat, a brown suit and black derby hat. It is claimed that he has represented himself as an actor in one place, as chauffeur in another, and on other occasions as being otherwise engaged in the automobile business.

Any jeweler who may have received this round brass automobile clock to be repaired should obtain a liberal reward by telephoning to Chief of Police H. D. Cowler, of New Haven, who will immediately make arrangements for the culprit's arrest. The dial of this clock is made of German silver and has printed on it the word "Chelsea." It has a heavy cast brass case and can easily be distinguished from an ordinary lock.

Death of Martin Kesmodel.

BALTIMORE, Md., March 21.—In the death of Martin Kesmodel on Wednesday, the city loses one of its oldest of old-time jewelers. Mr. Kesmodel was 78 years old, his death being due to a complication of diseases, he having been ill since Christmas. He was born in Ehrfurt, Germany, and came to this country in 1834, settling in Baltimore. He served his apprenticeship under John Johannas, a manufacturing jeweler, and later started for himself, opening a shop on Wine Alley, and removing later to Bank Lane. He continued here until his retirement some years ago, being then one of the leading manufacturing jewelers of the city. He then turned his attention to financial matters, and with Ernst Hoen organized the German-American Fire Insurance Co., of Baltimore, being

its president from 1886 until 1892, when he resigned.

Mr. Kesmodel was twice married, both wives having died. He is survived by a brother, Gustav Kesmodel, of Washington, D. C., and four sons: Charles Kesmodel, Carbon Hill, Ala.; Frank B. Kesmodel, Rossville, Ga.; and William E. and Martin Kesmodel, Jr., Baltimore. The funeral services took place from his late residence, 1533 W. Lexington St., this morning.

Death of Lawrence Hope.

ST. PAUL, Minn., March 17.—Lawrence Hope, 242 E. 7th St., this city, was struck and instantly killed by the Omaha flyer as he was crossing the tracks at Post Siding, at 7 A. M. to-day.

Mr. Hope walked around a standing train, in front of the engine. Heavy smoke was pouring from the stack of the engine and this floating down the tracks completely hid from view the Omaha tracks toward the approaching train. Mr. Hope stepped on the Omaha tracks directly in front of the flyer and was struck with terrific force.

The deceased had been engaged in business here for the past 17 years, having succeeded to the business of Wm. Anderson, who died several years ago. Mr. Hope was a practical jeweler, of excellent character, and enjoyed the esteem of a large circle of friends who have been much grieved to learn of his untimely death.

Creditors Ask That Naum Rosenberg, Philadelphia, Pa., be Declared Bankrupt.

PHILADELPHIA, Pa., March 23.—After weeks of efforts to avert bankruptcy and effect a settlement with his creditors by which he would be enabled to continue business, the financial difficulties of Naum Rosenbaum, a retail jeweler with a large and attractive store at 19 S. 9th St., above Chestnut St., reached a crisis Saturday. Then a creditors' petition was filed to have him adjudged a bankrupt and the store for the time is closed.

The petitioning creditors and the amounts claimed to be due are: James E. Blake & Co., \$346.75; C. G. Cook Co., \$160.45; Warren & Williams, \$360.12. It is known that other prominent wholesale jewelers are interested.

Jewelers' Gold Bars Withdrawn and Exchanged at New York.

Week Ended March 21, 1908.

The U. S. Assay Office reports:

Gold bars exchanged for gold coin.....	\$266,134.93
Gold bars paid depositors.....	40,626.00
Total	\$306,760.93

Of this the gold bars exchanged for gold coin are reported as follows:

March 16.....	\$88,234.84
" 17.....	67,050.53
" 18.....	37,888.54
" 19.....	15,487.55
" 20.....	36,849.73
" 21.....	20,623.74
Total	\$266,134.93

C. E. Hobson, Chariton, Ia., has sold his stock to Leland A. Ownes. Mr. Hobson seeks a new location.

An Attractive Exhibition of American Precious Stones Opens at New York.

A most attractive exhibition of precious and semi-precious stones in the rough, gem crystals and cut stones, was opened to the public by invitation yesterday by the Himalaya Mining Co., at its offices, 537 Fifth Ave., New York. The object of the display is to acquaint the public with the production of the company's mines, and about 10,000 invitations have been issued.

The gem mines of the company are situated in California and consist of turquoise mines in San Bernardino County, tourmaline mines in San Diego County, and chrysoprase mines in Tulare County. These mines produce gems of remarkable brilliancy.

The display of tourmaline shows gems in rich shades of ruby, red, pink, green, yellow, brown and white, besides formations combining two or more of these colors. One crystal on exhibition weighs 5,420 carats, and has perfect termination at both ends. Another piece of the same kind of crystal has been carved into the shape of a woman's head. The rough material is shown in a number of exhibits of different sizes.

No less interesting is the exhibit of chrysoprase. This display contains specimens in beautiful shades of emerald and apple green color in a variety of sizes and shapes. Noticeable among the exhibits is a piece carved into a representation of an owl.

The exhibit of turquoise, jade, opals and other precious and semi-precious stone in the rough and cut is well worth careful inspection. Rough diamonds and emeralds in the rock are shown together with opal matrix containing opals.

The rough stones are cleaved and split and then go into the factory room on the same floor, where they are passed through all the processes of cutting and polishing and come out ready for selling.

The exhibition will continue during the remainder of the week.

LETTERS TO THE EDITOR.

Made Petitioners Without Their Consent.

NEW YORK, March 19, 1908.
 Editor THE JEWELERS' CIRCULAR—WEEKLY:
 We have noticed, with surprise, in your issue of March 11 that our name has been used as one of the three creditors who put the firm of the Shrouds-Adcock-Teufel Co. into bankruptcy. Permit us to say that we had absolutely no knowledge of such proceedings, and that if our name has been used it has been without our consent or approval. Our policy has always been a conciliatory one, and during this trying period it has been our constant endeavor to extend to our friends all the material help at our command.

In justice to the Shrouds-Adcock-Teufel Co., as well as to ourselves, we would request you to publish this letter.

Very respectfully yours,
 FERA & KADISON,
 W. Fera, Secretary.

The Huteson-Hannay Co., Seattle, Wash., has been succeeded by the Huteson Optical Co.

ADDISON W. WOODHULL, President.
FRANK K. HUFF, Vice-President.

GILBERT T. WOODHULL, Treasurer.
WILLIAM J. McQUILLIN, Secretary.

MOUNT & WOODHULL,

IMPORTERS OF **DIAMONDS,**
OTHER PRECIOUS STONES,
PEARLS, ETC.

MAKERS OF **FINE**
DIAMOND
JEWELRY. **26 Maiden Lane,**
(Southwest Corner Nassau Street)
NEW YORK

EMERALDS, DIAMONDS AND PEARLS

BAGG & CO.
Successors to BAGG, PERINE & CO.
IMPORTERS
452 FIFTH AVENUE, at 40th Street
NEW YORK

TELEPHONE NUMBERS:
917-918 BRYANT

CABLE ADDRESS:
MILBAGG

RUBIES AND SAPPHIRES

F. A. JEANNE
BLACK OPALS

5 Square de l'Opera PARIS, FRANCE

Cable Address
"GEMFINDER"
Western Union Code

STERN BROS. & CO.,
CUTTERS OF
DIAMONDS,

CUTTING WORKS:
138-142 West 14th St., N. Y. **68 Nassau St.,**
NEW YORK.

CHICAGO, LONDON.
103 State Street. 29 Ely Place.

CENTENNIAL TIMERS



- Without question the best plain and split second timers made.
- Register with scientific precision. Substantially built and mechanically perfect.
- Invaluable for athletic, mechanical and scientific observations. Cased in nickel. Much in demand during the racing season.
- We also carry split chronographs with minute registers, cased in gold, gold filled and sterling silver.
- All makes of American cases and movements.



Cross & Beguelin

31 Maiden Lane, N. Y.
Established 1863 Telephone 480 John

Jewelers Board of Trade Issues Official Statement as to the Condition of the Diamond Trade.

A meeting of the directors of the Jewelers Board of Trade, New York, was held Monday afternoon to take formal action toward sending out an official statement as to the condition of the diamond trade, this being necessitated by the many erroneous statements that have appeared in the public press in relation to the diamond market.

The directors decided to send the following letter to the trade and public setting forth the exact condition of affairs, showing the errors of many of the statements published in the daily press. The letter was given to the Associated Press and the daily newspapers yesterday, and also sent to the members of the Board and the retail jewelry trade:

The letter reads:

NEW YORK, March 21, 1908

TO THE TRADE:

The Jewelers Board of Trade, whose membership comprises nearly all the important firms in the diamond business, jewelry and kindred trades throughout the country, in view of the many recent statements appearing in the daily press concerning the nature prices of diamonds, and in order to correct any misapprehension on the part of the public and the trade because of newspaper reports, has made a most careful investigation of this subject and desiring to put the situation briefly and fairly before the public submits the following statement.

The mining of diamonds for the consumption of the entire world, or say about 75 per cent. of all the diamonds mined, is in the hands of only two corporations, namely: The De Beers and the Premier Diamond Mining companies, the directors of both of which are men of unquestioned financial strength and keenly alive to the industrial and financial situation, both here and abroad. Through a powerful London syndicate, the product of these two companies is sold to the cutters.

It is to be remembered that the agreement between the DeBeers Co. and the London syndicate remains in full force and only the renewal of the agreement now existing between the Premier Diamond Mining Co., and this syndicate is now being considered, but whether the same is renewed or not the prices of diamonds will not in the least be affected because the officers of both the De Beers and the Premier Diamond Mining companies, as well as the London syndicate, have given us positive assurance that under all circumstances prices will be upheld. Assurances of this fact were cabled on March 19, all over the world, direct from the mining companies' offices in London.

On March 21, cable advices were received here from London, stating that the De Beers and the Premier Diamond Mining companies had made a contract in which they agreed that there shall not be the slightest reduction from the present prices of diamonds. These statements of all parties interested in this important industry must undoubtedly evidence the fact that the same conservative policy that has always prevailed in the past will be firmly maintained.

In support of these statements, it might be mentioned that the agreement between the London syndicate and the Premier Diamond Mining Co. has only been in operation during the past five and one-half months and prior to that time the product of this company has always been sold direct to the cutters and no rupture has ever occurred between these two companies (the De Beers and the Premier) during the many years that this way of marketing their product has been in vogue.

It is unreasonable to assume that these relations which for so many years have existed should all at once be interrupted by the cutting of prices, particularly when it is a well known fact that the entire industrial and commercial situation is daily improving.

Yours truly,

THE JEWELERS BOARD OF TRADE,
Leo Wormser, President.

D. L. Safford, Secretary.

Experts Denounce Lemoine Process as Impossible.

PARIS, March 19.—The experts who were appointed by the court to investigate the methods used by the electrical engineer, Lemoine, who claimed to be able to manufacture diamonds, reported that it is impossible to make gems by this method.

Lemoine is under arrest, charged with having swindled Sir Julius Wernher, of Wernher, Beit & Co., out of more than \$300,000 through his alleged invention.

KIMBERLEY, March 17.—The De Beers Consolidated Mining Co., Ltd., has decided to close the Dutoits Pan diamond mine on April 24 until the diamond industry improves. This decision was contemplated for some time.

The Dutoits Pan mine is famous for its stones of high value. The output, however, is small, and the cost of mining the stones is about double what it is in the other mines.

M. G. Wilkinson has succeeded A. F. Thompson in the jewelry and optical business at Adel, Ia.

Games Rolled Last Week by the Jewelers' Bowling League.

As the close of the bowling season draws nearer, the interest in the contest for first place in the Jewelers' Bowling League, of New York, is becoming more marked. The N. H. White & Co. and the Cross & Beguelin teams are now at the head of the list, and in all probability the championship lies between these two teams. The White team is two games ahead at the present time, and next Monday night, when these teams meet, the championship will hang in the balance.

Those who have not already secured tickets for the banquet on the evening of April 4, should give the matter attention at once.

The following were the scores of the teams in the games rolled last week:

March 16.—A. A. Webster & Co.	787	847	861
vs. Julius King Optical Co.	811	769	781
March 17.—Cross & Beguelin.	871	863	897
vs. C. F. Wood & Co.	917	929	798
March 18.—Jos. Fahys & Co.	809	860	847
vs. Aikin-Lambert Co.	765	793	908
March 19.—N. H. White & Co.	881	857	922
vs. C. F. Wood & Co.	826	836	848
March 20.—C. F. Wood & Co.	728	923	846
vs. A. A. Webster & Co.	846	769	741

STANDING OF TEAMS.

	Won.	Lost.	High score.	Per cent.
N. H. White & Co.	44	13	1,014	.772
Cross & Beguelin.	42	15	1,017	.737
Cooper Diamond Co.	39	21	1,045	.650
C. F. Wood & Co.	31	20	943	.608
Tiffany & Co.	34	23	994	.596
Aikin-Lambert Co.	32	28	967	.533
Jos. Fahys & Co.	31	29	951	.517
A. A. Webster & Co.	22	38	916	.367
H. W. Wheeler & Co.	13	38	922	.255
Julius King Optical Co.	11	43	889	.204
L. E. Waterman Co.	10	41	879	.196

B. Kahn & Bros., Baltimore, Md., File Voluntary Petition in Bankruptcy.

BALTIMORE, Md., March 22.—Benjamin Kahn and Bernard Kahn, retail jewelers and opticians, at 305 W. Lexington St., trading under the firm name of B. Kahn & Bros., were adjudicated bankrupts by consent yesterday. Benjamin Rosenheim and Edward A. Weiller, who bonded for \$5,000, were appointed receivers for the assets by Judge Morris in the United States Court. They were authorized to continue the business for a period not exceeding 60 days.

The petition in bankruptcy was filed by the following creditors: Reinhard & Pattison, Siegel, Rothschild & Co., Lewis Baer & Co., Henry C. Garthe, Julius J. Jenkins and Bernard Schmincke. Their claims amount to \$11,914.25.

Market Price for Silver Bars.

The following are the quotations of silver bars in London and New York, as reported by Zimmermann & Forshay:

	London.	New York.
March 17.	25 1-2d.	.999 Basis. \$57 1/4
" 18.	25 9-16d.	.57 3/8
" 19.	25 5-8d.	.57 1/2
" 20.	25 5-8d.	.57 1/2
" 21.	25 1-2d.	.57 1/4
" 23.	25 9-16d.	.57 3/8

J. T. Xander moved recently from South Bethlehem, Pa., to 409 N. 10th St., Reading, Pa.

August Henke will move, May 1, from 221 Glenridge Ave., Montclair, N. J., into more commodious quarters in the Montclair Savings Bank building, at the same place.

WM. S. HEDGES & CO.,

IMPORTERS AND CUTTERS OF

DIAMONDS.

Precious Stones and Pearls.

170 Broadway, Corner Maiden Lane, New York.

27 Holborn Viaduct, London.



J. E. Walton recently opened a store in Green River, Utah.

Mr. Angliss has again engaged in business at Dickinson, N. Dak.

Rosaire Morin has started in business on Main St., at Crookston, Minn.

Dr. Fremont Lewis has opened a new jewelry store in Manzanola, Colo.

Frederick McIntyre, McAlester, Okla., contemplates organizing a manufacturing company in Kankakee, Ill.

Charles P. Herold has again engaged in business, having opened a retail store at 6233 Lancaster Ave., Philadelphia, Pa.

P. B. Simpson, formerly with Anderson & Thorson, Wahoo, Nebr., will open a jewelry store in Falls City, Nebr., April 1.

The Nelt Barr Co. is the name of a new concern which recently began business in Ashland, O. The store is located on E. Main St.

H. F. Fournety, a former student in the Kansas City Horological and Optical School, has gone to Van Wert, O., where he expects to go into business.

The Broadway Jewelry Co. has opened an attractively furnished new store at 629 S. Broadway, Los Angeles, Cal. Dr. H. B. Shillito is the principal owner.

The Coin Controlled Clock Co. is a new corporation in San Francisco, Cal. The capital stock is \$100,000, and the parties interested are: C. J. and Eugenia Kleeman, F. P. Kelly, F. E. and Leo Grotto.

Mr. and Mrs. R. G. Hall, who recently completed a course at the Kansas City Horological and Optical School, Kansas City, Mo., contemplate opening a jewelry store in Marysville, Ky. Mr. Hall will attend to the watchmaking and repairing and Mrs. Hall will do the engraving.

The Silver Standard, the clever little periodical issued by the Meriden Britannia Co., Meriden, Conn., improves with age, Vol. III, which has appeared in book form, being more attractive than any of the previous volumes. It contains a vast amount of information on interesting topics that were discussed 60 years ago, while several articles showing the growth of various cities, with illustrations of the main thoroughfares and business sections as they appeared in 1847 and as they appear to-day, are subjects of great historical interest. From this volume of *The Silver Standard* it would appear that the writers of the day took great pleasure in predicting the population of the United States 60 years thence and shows that they were most optimistic regarding the future greatness of the country. According to one prophet, the United States was to have a population of 400,000,000 in the year 1907, while another came much closer with a prediction of 100,000,000. *The Silver Standard* will appeal to all who enjoy historical reading.

PEARLS

NECKLACES, MATCHED PAIRS AND DROPS

SAUNDERS, MEURER & Co.

65 NASSAU STREET

NEW YORK

Goodfriend Bros.

IMPORTERS OF PEARLS

Sapphires
Rubies
Opals
Emeralds

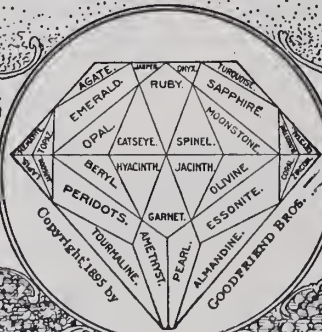

Aquamarines
Peridot
Gem Coral
Tourmalines

and OTHER
Precious and Imitation Stones

PEARL-OPAL-CORAL
& AGATE NECKLACES 9-11-13
Maiden Lane
NEW YORK

PARIS:
10 Rue Cadet.
PROVIDENCE:
212 Union St.

Geo. Brunswick, N.Y.

Philadelphia

Philip Cleckley, watchmaker, accepted a position last week with Riggs & Bros.

Samuel Kind, of S. Kind & Sons, has returned from a trip to the West Indies.

The Horological Club of this city meets Thursday of next week at 5th and Minor sts.

Percy Savory, of the Wadsworth Watch Case Co., canvassed the trade of this city last week.

Thomas M. Fox, watchmaker and jeweler, moved last week to 111 N. Front St., Darby, Pa.

W. H. Windolph is occupying his new store at the northwest corner of 12th and Gilbert Sts.

Joseph K. Davison, diamond dealer, 718 Sansom St., returned Friday from a pleasure trip to Florida.

Abe Sickles, of M. Sickles & Sons, contemplates soon going abroad as customary to purchase diamonds.

Ralph Wells, of Wells & Bro., Wilmington, Del., has returned to his store after a month's rest in western Pennsylvania.

L. P. White, wholesaler, 9th and Chestnut Sts., returned last week from a southern tour taken entirely for rest and recreation.

William H. Waltz, formerly a retailer in Perkasio, Pa., accepted a position last week with William Lautbach, 7032 Woodland Ave.

Benjamin F. Krischer, with M. Sickles & Sons, is receiving the condolences of the trade in sympathy with the death last week of his wife.

T. Bonnemi, watchmaker, has resigned his position with Robert Steel, Hammonton, N. J., to accept a position with T. C. Kremer, Phoenixville.

I. Press & Sons, 33-35 S. 8th St., contemplate rebuilding their stores next month. The store 33 S. 8th St. has only recently been acquired by the firm.

Milton Reed, a prominent Doylestown, Pa., retailer, was in this city a few days last week, accompanied by Mrs. Reed and combining business and pleasure.

Daniel Wagner, engraver, 725 Sansom St., is receiving the felicitations of his friends in the trade upon the arrival at his home, last week, of a baby girl—his first.

J. H. Yocum, diamond setter, who recently closed out his business at 725 Sansom St., has accepted a position with the Heintz Co. as a traveling salesman.

Harry Cromwell, watchmaker, has resigned his position with Charles Braun, Broad St. and Washington Ave., to accept a position with Harry Davis, 5123 Market St.

Howard Stuessy, watchmaker, with John D. Smedley, 725 Sansom St., has given up the business on account of illness and will seek restoration of health by taking up his home on a farm.

John Oberholtzer, of the firm of J. B. Bechtel & Co., purchased last week a home at 4703 Greene St., Germantown, to which he will remove this week with his family from 4714 Wayne Ave.

S. Rosenblatt, retailer, 2605 Germantown Ave., above Cumberland St., is relieved that the man who recently attempted to "blim-flam" him out of a diamond ring, but who was detected and captured, was sen-

tenced last week to 18 months in the penitentiary.

Howard V. Stratton, retailer, Mt. Holly, N. J., was in this city last week purchasing jewelry to stock his new store in Bordentown, N. J., which will be opened soon. Mr. Stratton intends giving up his Mt. Holly store.

Christopher Loeffler, for a quarter of a century a retailer at 1004 Girard Ave., has announced his retirement from business, to take effect April 1, when his son, Charles M. Loeffler, will take over the business and continue it at the old stand.

It was reported in the local trade last week that H. F. Freeman, of West Chester, has gone to Europe to join in England A. N. Peoples, a prominent Chester retailer, and after a tour of the British Isles will accompany Mr. Peoples home.

A man suspected of having been implicated in the robbery of the jewelry store of the J. J. Sweeney Jewelry Co., Houston, Tex., was arrested in this city last week, but so far the police have not been able to connect him with the robbery.

William James, Omaha, Nebr., is the guest of his brother, J. A. James, a watchmaker and jeweler of Swedesboro, N. J., on a pleasure trip east. The brothers spent several days in this city last week, sight-seeing and buying for their stores.

Charles P. Herold, a well-known old-time manufacturing jeweler of this city, who has been living quietly in Overbrook for some years, has again engaged in active business, opening a retail store at 6233 Lancaster Ave. which he quaintly calls "A Tinker's Shop."

Robert L. Saunders, 11-13 S. 8th St., and J. C. Mitchell, 27 S. 8th St., testified in the License Court last week, protesting against the location on 8th St., between Chestnut and Market Sts., of a saloon for which application was being considered by the court.

There has been listed on the Philadelphia Stock Exchange \$551,400 additional capital stock of the Keystone Watch Case Co., being part of the 10,000 shares recently authorized by the directors. The total amount of this stock outstanding and listed is now \$5,551,400.

John W. Ford, retail jeweler and optician, 618 East Girard Ave., has been slated as the Republican candidate for coroner of Philadelphia. With the party strongly entrenched this virtually means the election by an overwhelming majority of Mr. Ford, who will assume office then Jan. 1 next. Mr. Ford is widely known to the trade, and is popular with his business associates.

Picturing himself as a worn-out old crook, James Collins, who said he was from Portland, Ore., and at one time had served two years in jail for stealing a tray of diamonds from a Denver jeweler, caused himself to be arrested here last week and committed to prison for 90 days as a suspicious character. The police are trying to learn whether his story is true.

Among the out-of-town jewelers visiting the wholesale district last week were the following: A. Lehrberger, Salem, N. J.; Gus. Lanz, Norristown, Pa.; H. S. Kratz, Souderton; D. H. Krause, North Wales; H. B. MacFarland, Downingtown; John MacPherson, Mauch Chunk; T. C. Kremer

and E. L. Thomas, Phoenixville; Mrs. H. Bolte, Atlantic City, N. J., and H. S. Landis, Coatesville, Pa.

The publication by THE CIRCULAR-WEEKLY last week of facsimiles of the cablegrams exchanged between New York diamond dealers and representatives of the South African syndicates was read with interest by jewelers here and gave a great deal of satisfaction for the effect the publications had in diminishing uneasiness among the trade, which, however, had not been alarmed by daily newspaper reports to any extent.

At the solicitation of reporters of the daily newspapers Clement Weaver, of the Bailey, Banks & Biddle Co.; William R. Eisenhower, of J. E. Caldwell & Co.; Col. J. Warner Hutchins, president of the Jewelers' Club, and other prominent diamond dealers, issued statements discountenancing reports of breaks in the price of diamonds and the exaggerated and colored statements of warfare between diamond mine owners.

J. A. Caldwell, senior member of the firm of J. E. Caldwell & Co., was one of the delegation of Union League members who attended the funeral Saturday of J. G. Darlington, formerly president of the League and proprietor of one of this city's exclusive stores. Mr. Darlington in his business career had become well acquainted with the leading jewelers of this city and New York, and was a heavy buyer of fine jewelry.

C. F. Berger, who has a retail store at Moyamensing Ave. and Wolf St., came near being the victim of a canine sneak thief last week and losing thereby a pair of diamond earrings worth \$100. A customer entered, accompanied by a fine collie dog. While engaged in inspecting some jewelry the dog busied himself examining the stock in the bulk window, to which he had noiselessly made his way by walking behind the counter. A box containing the earrings took the dog's fancy and his jaws closed on the box. The dog was making his way toward the door as his master was about to leave, when the protuberance from his mouth was observed. His master coaxed him to let go the box and then for the first time both master and jeweler discovered what the dog had done. Mr. Berger lost no time in rescuing the diamond earrings, and is being congratulated on their recovery.

William Lesser, of New York, was last week appointed by Judge Holland in the United States District Court for eastern Pennsylvania ancillary receiver of the alleged bankrupt estate of Maurice C. Dreshfield, a diamond importer of New York, upon a petition filed by J. Howard Reber, attorney for Rudolph Breidenbach, of New York. Mr. Breidenbach, a creditor of Dreshfield to the extent of \$100,000, representing the value of loose diamonds, which he says were "delivered to the alleged bankrupt by means of false representations," declared that many of his diamonds have found their way into the hands of jewelers of this city, among them Sperling & Stern, Daniel Meyers, the People's Trust Co. and the General Trust Co., and that it is necessary to extend the receivership from New York City to embrace this city in order that the assets of the alleged bankrupt may not be disposed of and the creditors deprived of their claim to them.

MONTANA SAPPHIRES

AT ATTRACTIVE PRICES

Where uniformity of size, evenness of color and quality are essential, our stock of Montana Sapphires particularly commends itself.

Pearls and practically every precious and semi-precious stone but the diamond.

BUY FROM THE CUTTERS

AMERICAN GEM & PEARL COMPANY

14 & 16 CHURCH STREET, NEW YORK

London, 16 Holborn Viaduct

Paris, 39 Rue de Chateaudun

FROM MINES TO MARKET

Canada Notes.

Mark T. Thomas, Ottawa, has assigned to W. A. Cole. A meeting of creditors was held Saturday, March 21.

The Canadian Jewelry & Importing Co., Montreal, has dissolved, the business being now continued by Abraham Myers individually.

Out-of-town buyers calling on the Toronto, Ont., trade last week included: W. P. Cooke, Fort William; H. B. Rosevear, Port Hope; J. Hollingshead, Tottenham; John Gabel, Listowel; and G. H. Zwicker, London, all Ontario.

J. H. Jackson, Huntsville, Muskoka, one night recently went up on the roof of his house to cut away some ice, and while adjusting the ladder, slipped and fell 20 feet to a platform below, striking an electric wire in his descent. He fell on his head and was taken up unconscious, dying about an hour later. Mr. Jackson came to Huntsville about eight years before from Orillia, Ont., and was a successful business man. He was 37 years of age and leaves a widow and three daughters.

A gang of burglars broke into several buildings at Toronto Junction, Ont., Tuesday night, March 17, and endeavored to effect an entrance into A. C. Stanner's jewelry store by cutting a piece of glass out of the window. They were frightened away by persons living above the store, who gave the alarm. At an early hour in the morning they were rounded up by the police, who shot one of them in the thigh while they were attempting to escape. The wounded man, James Sullivan, and one of the others, John Reilly, have criminal records. A quantity of jewelry found in their possession has been identified as the spoils of former burglaries.

Diamonds valued at \$1,200 were stolen at noon, Wednesday, March 11, from the jewelry store of J. F. Higginbotham, Brandon, Man., when the proprietor was absent at lunch, having left the store in charge of Bert Sutherland, a clerk. A man entered and asked to have a crystal placed in his watch. While Sutherland was fixing the crystal in the workshop at the rear of the store two other men came in and were noticed about the front of the shop for a few minutes. They left suddenly, and Sutherland returned the watch to its owner, who also left without exciting any suspicion. When Mr. Higginbotham came back from lunch he found a show case open and a tray containing the diamonds missing. It is supposed that the man in search of a watch crystal was a confederate who adopted this plan to send the clerk to the back of the shop while his partners got away with the goods.

The Arnstine Bros. Co., Cleveland, O. is busy getting the annual souvenir book ready for the printer. This book will contain about 150 interior views of the leading retail jewelry stores in various parts of the United States, as well as photographs of about 100 of the most prominent retail jewelers, and will not only be a work of art, but will be something unique in its way and extremely interesting for the retail jeweler, for whose sole use it is intended.

CORAL

All Kinds of Coral
Specialties for Jewelers

DROPS
BUTTONS
LENTILLES

CORAL
NECK-
LACES

All Shades
and Sizes

Graduated and
Uniform



CORAL MANUFACTURING COMPANY

CORAL

Extra Rose
CORAL
A Specialty

Gold Medal
St. Louis, 1904

Grand Prix
Liege, 1905

BORRELLI & VITELLI

3 Via Amedeo,
Terre del Greco Italy

401 Broadway, New York
Telephone, 5412 Franklin

19 Rue d'Hauteville,
Paris, France

William G. Morstrom & Co.

DIAMOND IMPORTERS and MANUFACTURING JEWELERS

Memorandum Packages of Loose or Mounted Stones on request. We solicit Special Order Work.

78-80 STATE STREET

CHICAGO, ILL.

Pittsburg.

W. J. Johnston spent a few days of last week in New York on business.

Samuel Weinhaus, of S. & B. C. Weinhaus, returned last week from a business trip to New York.

Abraham Lewis, 207 Fifth Ave., is taking a course in physical culture, and after six months' treatment, he says he never felt better in his life.

C. C. Marsh, of the Marsh, Brown & Co., who has been at Mt. Vernon, Pa., for some time because of illness, will return to Pittsburg just as soon as the weather settles.

Mrs. Charles Biechle, aged 77 years, and mother of Mrs. A. E. Siedle, died a few days ago at Canton, O. She was the mother of 15 children, six of whom survive besides her husband, who is 81 years old. The couple recently celebrated their 57th wedding anniversary.

Goddard, Hill & Co. have decided to re-lease their present quarters in Fifth Ave. another year. The firm had intended renting space in the new Keenan building, but was unable to come to satisfactory terms with the renting agents of the building and decided that it was best not to move.

The Jewelers' Duckpin League rolled the dice games last Thursday night. The seeds took two out of three games from Roberts Team No. 2; Vilsack's took two from the Terheydens and Wattles Team No. 1 took all three games from Wattles No. 2. The contest is becoming very interesting.

S. Davis, of S. Davis & Co., who had been at Marckleton sanitarium for several weeks, following an operation in New York, has returned to his home in this city, but it will be several weeks before he is able to resume business cares, his physicians advising that he take life easy until he thoroughly regains his strength.

Among the out-of-town jewelers who visited Pittsburg last week were the following: Mr. Little, S. T. Little Jewelry Co., Cumberland, Md.; Carl Leighner, Butler; Frank Worrell, Canonsburg; Frank Murdock, Ligonier; F. H. Hayes, Washington; B. E. Brown, St. Marys; John Lanzendorfer, Punxsutawney; J. M. Langendorf, Ionongahela; Asa Joseph, Donora.

M. Bonn has sold his residence property at Sheffield and Fulton Sts., North Side, where he has lived for the last 20 years or more and intends to go to the East end, where he expects to live in the future. The lot is 48 x 138 feet, and is improved with two dwellings, one containing 12 rooms and the other nine rooms, which were placed in an exchange transaction at \$25,000. The property exchanged is situated in the 14th Ward.

Another scare was given the jewelry district, situated within the flood belt, by the announcement last Thursday that the local rivers would reach a stage of 33 feet of water. M. Bonn & Co., Heeren Bros. & Co., S. & B. C. Weinhaus, the Jos. Horne Co., and numerous other merchants all made preparation to shut out the flood, but the rivers only reached a stage of 27.3 feet, and comparatively no damage was sustained to any of the firms, though they

were put to lots of inconvenience. Thirty feet of water brings it into the basement of most of the buildings in lower Penn Ave. It also reaches a number of jewelers in Federal St., North Side, but the flood did not reach them on that side of the river.

John M. Roberts, of the John M. Roberts & Son Co., last week was extensively interviewed by some of the Pittsburg papers regarding the diamond situation, and Mr. Roberts gave it as his opinion that there will be no lowering of prices under any consideration. The diamond situation is attracting a great deal of attention in this city. Some of the jewelers complain that the recent published stories that prices would be lowered has caused prospective customers to hesitate about buying.

Joseph C. Wasson, chairman of the finance committee of Pittsburg councils, and manager of the jewelry department of the Joseph Horne Co., has been made chairman of the commission appointed by Mayor Geo. W. Guthrie, to select a new City Hall site. The commission is composed of well known business men, members of the Pittsburg Chamber of Commerce and members of councils. The commission met last week and elected Mr. Wasson as its guiding head. The market house site which, if adopted, will necessitate the taking of a large amount of property, some of which is now occupied by jewelers, appears to be the choice of everybody, although numerous other sites are being proposed. The commission will make its recommendations to councils.

H. Walter Lett, an expert horologist, with J. R. Reed & Co., has just completed one of the most difficult and expensive pieces of work perhaps ever done in this city. He has replaced 30 parts of a Swiss minute repeater, which had been dropped on a hard road and run over by an automobile, the parts having been broken and lost. The watch cost about \$100, and when the accident happened it was sent to New York City for an estimate of what the repairs would cost. The owner of the watch, John W. Garland, a well known Pittsburger, and a member of the Bailey-Farrell Co., was informed that it would cost from \$80 to \$100. The watch was finally taken to Reed & Co. and Mr. Lett was assigned to do the work, and made and replaced all of the broken parts. Mr. Lett is quite proud of his achievement, as are the members of the firm which employ him. The watch now keeps perfect time.

Williamsport, Pa.

TRADE CONDITIONS.

Business here during the new year has been fairly good and the indications are that Williamsport will not feel much of the "hard times" as all the factories, machine shops, silk mills, saw mills, and the different industries are working almost full time.

Chas. C. Mussina spent part of this week in New York and Philadelphia.

Ralph Mussina and Chas. Eldon attended the Sportsman's Show at Philadelphia last week.

Joseph C. Gibson, formerly with Robt. Moore, has opened a repair shop on W. 4th St.

Harry Leinbach, of Leinbach Bros., Lock Haven, was a visitor to this city for a few days last week.

There was quite an excitement when fire was discovered over the jewelry store of J. Wood Mussina, but by the promptness of the fire department the fire was extinguished without doing much damage.

Lancaster, Pa.

John J. Bowman, of Ezra F. Bowman's Sons, visited York, Pa., last week.

John T. Richards left last Friday for Oklahoma, where he expects to open a repair shop.

Willis B. Musser, Philadelphia, was in Lancaster last week in the interest of the Non-Retailing Co.

Frederick R. Young, for 10 years night watchman at the Hamilton Watch Co.'s factory, died March 17.

James R. Fairchilds, Lewisburg, Pa., has entered the local technical school as a student in watchmaking and engraving.

Philip S. Carman, Knoxville, Tenn.; James Trout, Buffalo, and C. D. Billinger, Pittsburg, visited Lancaster last week.

G. William Reisner has just finished for the senior class of St. John's University, Collegeville, Minn., a handsome set of gold class pins.

Amer G. Young, an Atlanta, Ga., jeweler, spent several days in Lancaster last week with friends, stopping over on his way back home from New York.

Ernest Grimbaugh, a former Lancaster county watchmaker, has written relatives here that he and Oscar Troutwine have formed a partnership and will open a jewelry store in Louisville, Ky.

Robert Anderson was sent to jail last week for theft, and when his record was looked up it was found that he had been indicted in September, 1906, for stealing a lot of jewelry, but sentence had been suspended to give him a chance to reform.

Among the guests at the annual banquet held by the Rosie O'Grady Club, at the Stevens House, March 17, were G. Z. Rhoades and Jacob R. Groff. The latter was presented by the club with a beautiful silver loving cup, 15 inches high, with ebony pedestal, which was furnished by Aug. Rhoades.

It is a current rumor here that a number of Lancastrians, two or more of whom were formerly interested in the local watch factory, will attempt to buy the Trenton Watch Co.'s plant when it is sold next month, and it is said it will be removed to Lancaster. The parties whose names are mentioned refuse to discuss the matter or make any statement at present.

A man giving the name of "Dick Turpin," doubtless assumed, was arrested at Hanover, Pa., March 17, on suspicion of having been one of the three men who a short time ago smashed a show window of Archie K. May's jewelry store at York and stole \$600 worth of rings. The man, intoxicated, called at a photograph gallery, where he offered to sell four waist pins at a cent apiece. They were afterward found to be solid gold. He had other jewelry, but when arrested this was gone. He is now in the York jail awaiting examination.

EICHBERG & CO.,

IMPORTERS AND CUTTERS OF

DIAMONDS,

65 NASSAU STREET, (Prescott Building.) NEW YORK.

VARISCITE SOHN & HYMAN

Sole Agents

47-49 MAIDEN LANE
NEW YORK

The Newest Stone for High Class Jewelry

"ASK YOUR JOBBER"

The Heavy Shanks

COUPLED WITH
SUPERIOR WORKMAN-
SHIP AND UP-TO-DATE
IDEAS ARE WHAT
INDIVIDUALIZE THE

UR RINGS

The Untermeyer-Robbins Co.

Seventy-One Nassau Street, New York

North Attleboro.

G. Cheever Hudson returned Thursday from the west.

Walter Duncan has returned from a trip for C. Ray Randall & Co.

The additions to the Whiting & Davis and Plainville Stock Co. shops are complete and ready for occupancy.

Frank J. Ruggles returned Saturday from the west, where he has been traveling in the interests of W. H. Bell & Co.

Percy Ball, head designer for Frank M. Whiting & Co., delivered an interesting address on Tuesday before the Men's Club of the Episcopal Church on "The Development of Art in America."

A second dividend of 30 per cent is expected to be declared before four months are over to the depositors of the Jewelers' National Bank. There is now a strong possibility that 100 cents on the dollar will eventually be received.

Furbush, Swift & Fisher, who have been located in the Union Power building for several years, will remove soon to the Manufacturers' building. The concern will take the quarters heretofore occupied by the Crown Mfg. Co. on the first floor.

George K. Webster, George W. Cheever, of Cheever, Tweedy Co.; Charles T. Paye, of Paye & Baker Mfg. Co.; Edward D. Sturtevant, of Sturtevant & Whiting; Charles O. Mason and William H. Bell were chosen last week members of the town finance committee.

In the municipal election last Monday, William H. Bell, a manufacturing jeweler, and John A. Rose, an employe of T. G. Frothingham & Co., were elected selectmen. Mr. Bell was high man on the ticket with 778. In the organization Mr. Bell was chosen chairman of the board. Wallace G. Franklin was elected electric light and water commissioner, and John P. Bonnett was chosen trustee of the public library.

A hearing was given before the railroad commissioners on Monday on the application of the Interstate Consolidated Street Railway Co. to act as a common carrier of freight and express. The selectmen gave the privilege two years ago, but it has been held up by the commissioners. The granting of the privilege, it is believed, would be a great benefit to the jewelers.

Washington, D. C.

TRADE CONDITIONS.

Business in general is progressing quietly with prospects encouraging for the Spring trade.

Isidor Kahn, 1339 F St., N. W., is holding a special sale of the stock of Keene, of Baltimore, which he has purchased.

S. Desio, F St., N. W., has renewed the lease on the present store for a number of years. This house has recently had the store ceiling cleaned, so that it looks equal to new, and by a process that requires no movement of stock while it is being done.

A suit for \$20,000 damages was recently filed by Louis Sklar against Marcus Korman, a local instalment jewelry dealer. The complainant alleges that Korman accused Sklar of stealing a diamond ring, which he purchased of him on the instalment plan and caused his arrest. When tried on the charge, Sklar says he was acquitted.

Providence.

Harry Mays, of the George W. Dover Co., was in New York last week.

E. B. Shepard, a representative of Albert Orsch & Co., sailed for Europe Saturday on the *Lusitania*.

Eugene A. Eddy, representing the E. A. Eddy Machinery Co., was in New York on a business trip last week.

Mr. and Mrs. Frank B. Reynolds will sail from New York Wednesday on the *Atlantic*. They will join their daughter on the other side.

Nathaniel Barstow, Frank F. Carpenter and Louis L. Angell have obtained articles of incorporation and will do business under the name of the N. Barstow Co., which is capitalized at \$27,000.

Accompanied by his wife, C. S. W. Reinhardt, a manufacturing jeweler of this city, sailed last week for a two months' tour of the continent. He will visit Germany during his stay in Europe.

Commissioner of Industrial Statistics George H. Webb has concluded the census, recently begun, of the unemployed. The total shows that there are only 18,777 unemployed in the entire State and that these include 1,465 jewelers. There are about 900 jewelry workers still working.

The imports received in this city last week amounted to \$29,789. The articles which were consigned to jewelers were: from Bremen, six packages of imitation precious stones; from Liverpool, one package of imitation precious stones, and from Southampton, one package of emery wheels.

The Yale Jewelry Mfg. Co. will open a shop in Pawtucket. It is capitalized at 100,000 and its officers are Edward J. Yale, president, and J. S. Jendron, secretary. Mr. Yale is the inventor of the Yale automatic button-making machines. The concern will manufacture collar and link buttons.

In the death of Philip E. Thayer, who died at his home in Pawtucket, March 12, manufacturing jewelers lose a close friend, and the city of Pawtucket a public spirited citizen. For years Mr. Thayer was engaged in the manufacture of brushes and was the treasurer of the P. E. Thayer Brush Mfg. Co.

Articles incorporating the Silverman Bros.' Mutual Relief Association have been secured. The purpose of the association is to provide relief for its members in time of sickness and distress. The incorporators are Charles Rotberg, Louis Shanbrun, John Silverman, Israel Silverman, and Sara Goldberg.

Justice Dubois, in the Supreme Court last week, handed down an opinion overruling the exceptions taken by Richard W. Farr to a verdict against him in the Superior Court. Farr was arrested about a year ago on a charge of forging an assignment of wages of Charles F. Fry, an employe of the Gorham Co. The amount involved was only \$10, but the litigation has been in the courts continually since the time of Farr's arrest. He was indicted by the Grand Jury and was later found guilty after a trial, and the opinion of Justice Dubois last week denied his counsel's motion for a new trial.

An act which will be far reaching in its effect if it passes both branches of the Legislature, was introduced in the House of Representatives last week by Assemblyman Olney Arnold, of this City. It is entitled "An act to diminish the danger of life in case of fire," and some of its provisions are of a drastic nature. Inasmuch as the bill, should it become a law, would compel owners of property in all parts of the State to make extensive alterations on their property, it is thought that a bitter fight will be made against its passage. The act will have a marked effect on the jewelry shops. In fact that industry will probably be the most severely hit in this city should the act become a law.

The fact that the jewelry business in this section is not so bad as current report has had it for some time past is evidenced in the number of new concerns which have recently opened shops in this city. The fact that the Superior Court has rendered a decision in which it holds that the Union Trust Co. is not insolvent, has also had its effect on the trade, and from now on the owners of shops of all sizes and styles are looking to a general betterment of business conditions. The bank is to reopen, and this announcement has had the effect of already restoring confidence and has given persons who have been a trifle shaky on account of the money market an opportunity to view the future with optimism.

Brockton.

Obed Lyon, for over 20 years proprietor of a retail jewelry store on Main St., at the corner of Crescent, has sold out his business, and will shortly retire from active business life. The purchaser of the store is Henry Dane. Associated with Mr. Dane is A. Kaplan, of Yarmouth, N. S. There are few better known men in Brockton than Mr. Lyon, who has conducted a successful business at the same store for a long period, coming to this city from Attleboro.

The suit of the S. D. Grossman Co., retail and jobbing jewelers, of this city, against Canning & Co., of 27 School St., Boston, has been settled satisfactorily to the plaintiffs. A Rockland man bought a diamond ring of the Grossman Co. on the lease plan and pawned it with Canning & Co. before the ring was entirely his property. Suit was then brought by the Brockton concern against the Boston firm for the value of the ring, and a settlement has been reached and the case will not be tried in the superior court, in which it was entered.

Reports on the progress of the arrangements for the convention of the commercial travelers to be held in Utica, in June were received at the meeting of the General Committee of the Utica Council of the United Commercial Travelers held at Bagg's Hotel recently. It was reported that Mayor Wheeler would deliver the address of welcome to the assembled delegations at the Majestic Theatre on Friday evening, June 12, and that there would also be a welcome by a representative of the Chamber of Commerce.

Attleboro.

Walter B. Marble, salesman, from this town, has been stopping the past few days at Pasadena, Cal.

Herbert C. Bliss and Ernest M. Bliss, of the Bliss Bros. Co., and Charles E. Bliss, formerly of Bliss Bros., are at Sea Breeze, Fla.

Fred Gilmore, for a considerable time foreman for the E. T. Bright Enameling Co., was presented a picture by associates last week. He proposes to move to New Hampshire and engage in another line of business.

The silver service presented to the battleship *Montana* by the citizens of that State was made and designed by Reed & Barton, Taunton, and it attracted considerable attention while on exhibition in the jewelry store of E. D. Tisdale & Son, in Taunton, recently. It is now on exhibition in New York.

David Low, who holds a responsible post with the D. F. Briggs Co., states there is no immediate prospect of the concern passing into the hands of a New York syndicate. Current rumor has made it appear such a transfer was on the eve of accomplishment, but he says the rumor has outrun the facts.

The West Silver Co., of Taunton, through Treasurer Arthur W. Williams, has filed the following annual corporation report: Real estate, \$8,000; furniture and fixtures, \$15,500; cash and debts receivable, \$9,039; manufactures and merchandise, \$24,012; capital stock, \$20,000; accounts payable, \$130; floating debt, \$11,500; profit and loss, \$24,421.

The annual corporation report of the Bristol Mfg. Co. was filed with the Secretary of State by Treasurer Sidney O. Bigney. The figures show: Machinery, \$74,239; cash and debts receivable, \$78,534; manufactures and merchandise, \$56,307; patent rights, good will and trade-marks, \$15,000; capital stock, \$36,000; accounts payable, \$133,420; profit and loss, \$54,660.

Fred Wilmarth, of the D. F. Briggs Co., has been appointed trustee to settle up the affairs of Leroy D. Braman. The latter was a jobbing jeweler who mysteriously disappeared last Fall while on a trip with his samples, vanishing in the neighborhood of Waterville, Me. He has never been heard from since, and the present action is the result of recent hearings in Boston before a referee in bankruptcy.

The Republican party will caucus March 31, and the town committee will present a list of prospective delegates to the State convention favorable to having the latter body send Hon. S. O. Bigney, of S. O. Bigney & Co., to the national convention. The delegation thus proposed includes Mr. Bigney, Frank Mossberg, of the Frank Mossberg Co.; Harvey Clap, of the Daggett & Clap Co., and Everett S. Horton, of the Horton-Angell Co. Col. Peter H. Corr, the leading Taunton manufacturer, issued a public statement last week exploiting Col. Bigney as the choice of thousands of Republican business men.

E. H. Rogers, formerly with L. H. Kirwin, Franklin, Minn., has severed his connection with that firm and left for his home in Viroqua, Wis.

ANNOUNCEMENT

On May 1st,

THE GORHAM COMPANY

will remove its Maiden Lane store to the New Silversmiths Building, Nos. 15, 17, 19 Maiden Lane, occupying the ground floor and basement.

THE STORE NOW OCCUPIED BY US
AT NOS. 21 AND 23 MAIDEN LANE,

FOR RENT

Apply to

GROSS^{AND} GROSS COMPANY
MANAGERS

COURTLAND E. HASTINGS, Agent
171 Broadway, Room 5

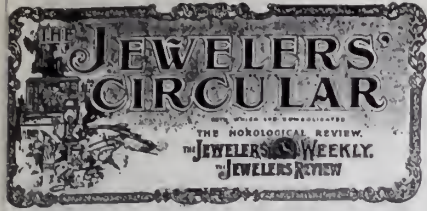

PUBLISHED EVERY WEDNESDAY BY
THE JEWELERS' CIRCULAR PUB'G CO.
 J. J. Mulford, Pres. & Treas. V. S. Mulford, V. P. & Sec.
 11 JOHN ST., COR BROADWAY, NEW YORK.
 TELEPHONE: CABLE ADDRESS:
 1448 CORTLANDT. JEWLAR, NEW YORK.

VOL. LVI. MARCH 25, 1908. No. 8.

Subscription in United States and Mexico, \$2.00
 Dominion of Canada, 3.00
 Other Countries in Postal Union, . . . 6.00
 Single Copies,10

Remit by check or money order. Remittances in money are at sender's risk.

Index to News and Special Articles.

	Page.
Wreath Presented by Swedish-Americans for the Bier of King Oscar. Illustrated on front cover; text on	44
Burma Pearl Fisheries.	43
Scenes in the Ivory Sale in London.	43
Little Practical Success in Making Artificial Precious Stones.	44
Reigning Paris Fashions.	45
A Unique Photograph.	45
J. Edward Boeck, Missing Diamond Broker, Arrested in San Francisco.	47
Consolidated Jewelry Firms of Cleburne, Tex., Make a General Assignment.	47
Exports of Jewelry, etc., From New York.	47
Kaplan & Co. Offer a Reward for Arrest of Missing Salesman	49
Bids Received and Contracts Awarded by Government Departments	49
Death of Samuel Thomas.	49
Milwaukee Jewelers Petition Common Council for Redress for Recent Destruction of Street Clocks.	49
N. Steen Commits Suicide by Hanging.	49
Friends Pay Last Tribute to the Late Charles Adler	51
Involuntary Bankruptcy Petition Filed Against A. Anzelewitz & Co.	51
Continuation of Examination in Bankruptcy of Joseph Brown & Co.	53
Grand Jury Indicts Pittsburg Jeweler on Charge of Creditors.	53
Bankruptcy Petition Against Max Marcus & Co.	53
R. C. Nelson & Co. Go Into Bankruptcy.	53
Bankruptcy Petition Filed Against Henry Wolf Co.	53
Beware of This Man With an Automobile Clock	55
Death of Martin Kesmodel.	55
Death of Lawrence Hope.	55
Bankruptcy Petition Against N. Rosenberg.	55
Gold Bars Withdrawn and Exchanged.	55
Exhibition of American Gems at New York.	55
Jewelers' Board of Trade Issues Official Statement as to the Condition of the Diamond Trade	57
B. Kahn & Bros., Baltimore, Md., File Voluntary Petition in Bankruptcy.	57
Experts Denounce Lemoine Process as Impossible	57
Games Rolled by the Jewelers' Bowling League. Demurrer and Exceptions Filed to Bankruptcy Petition Against M. C. Dreshfield and Geo. H. Carpenter	71
Compensation Through the Balance Spring by Effecting an Automatic Variation.	89-91
Watch Repairing—(Continued)	91
Two Carved Stone Sun Dials of the 18th Century	93
The Competitive Trial of Chronometers During the Year 1907 at the Observatory of Geneva	93
Railroad Watch Inspection and Its Relation to the Market for High-Grade Timepieces.	95
Rolling Shutter Intended to Thwart the Efforts of the Ingenious Burglar.	102
How to Meet the Competition of the Mail Order House—(Continued)	103
Chinching a Sale.	103
This Attractive Store the Result of Nine Years' Hard Work.	103
Workshop Notes and Queries.	105
Austrian Porcelain and Vienna Ware.	107
Buyers' Information Bureau.	109
American Participation Solicited in the World Exposition to Be Held at Rome and Turin.	109

Look Out for This **L** E T T E R S received from jewelers in Man. various sections of the country recently indicate that there is someone on the road soliciting subscriptions for THE JEWELERS' CIRCULAR-WEEKLY and THE OPTICAL REVIEW, as well as other publications, without any authority from this company, and, what is more, that he has received payment in a number of instances and given receipts for the money without ever accounting to the jeweler or to the company which he claims to represent. That he was in Virginia in December is evidenced by the fact that he took subscriptions for THE CIRCULAR-WEEKLY and THE OPTICAL REVIEW in Fredericksburg and signed the receipt as a representative of a Philadelphia publishing company, by whom he is not known. In the early part of February he had gotten up to the northern part of New York State, and among other places took subscriptions for THE CIRCULAR-WEEKLY and THE OPTICAL REVIEW in Ballston Spa, this time signing the receipt "The Jewelers' Circular Pub. Co., per J. Ordway Puller." In neither case was the subscription forwarded to this office, nor was the money returned to the party subscribing.

The man, who is described as a slight, short fellow, about 5 feet 6 inches high, weighing about 120 or 130 pounds, and about 26 years old, had evidently been drinking hard before he called at Ballston Spa. In one instance he took a subscription to THE CIRCULAR-WEEKLY and THE OPTICAL REVIEW at \$1 and another at \$2. In each case noted so far the receipt which he has given is made out on an ordinary yellow order blank.

Jewelers are warned to be careful in dealing with this man, and also warned to pay no money to any solicitor who cannot show a letter of authorization from The Jewelers' Circular Publishing Co. While in upper New York the man is said to have canvassed many orders, not only for THE CIRCULAR-WEEKLY and THE OPTICAL REVIEW, but for other publications as well. Jewelers who have had any dealings with him are requested to communicate with this office at once.

The Diamond Trade's Situation.

THE situation in the diamond trade cleared up materially last week, and one of the most gratifying changes was the attitude of the daily newspapers, which to a great extent not only ceased giving prominence to ill-founded and silly rumors about the diamond market, but in many instances succeeded in getting some authentic information on which to base their stories, thereby contradicting much of the nonsense published hitherto. The two cables received early in the week, which were published in facsimile in the last issue of THE CIRCULAR-WEEKLY, served in a great measure to contradict the rumors which had been spread and also to insure the trade and even the public, that the diamond market was in no danger. Particularly was this true of the cable of Mr. Busch, the representative of the Premier Diamond Mining Co., Ltd., stating that "The Premier company have no intention of lowering prices, regardless

"I am not a believer in spasmodic advertising; my principle is, keep pounding away at the reader all the time. When a season is dull I increase my advertising. That may seem odd. Many don't do it, but I do. That, I think, is one of the secrets of success. Instead of hanging back, waiting for a slack season to pass, I believe in advertising all the more."—Ex-Governor Douglas of Massachusetts, the largest shoe manufacturer in the world.

of continuation of present agreement with Syndicate."

While the strong statement of L. & A. Abrahams, head of the Syndicate, to the effect that "The Syndicate intend to maintain prices as hitherto," as reinforced by a later cable sent officially by the De Beers Mining Co., Ltd., and signed by the secretary, Mr. Tymms, to the effect that "The De Beers Company intend continuing working agreement with the Syndicate for the purpose of maintaining prices."

The agreement by which the product of the Premier company is sold, and which the Syndicate entered into October last, expires this month, and no official statement has yet been received as to whether or not the agreement will be renewed. The newspapers published a report from Johannesburg to the effect that the negotiations for renewals will no longer continue; and, while it may or may not be true, it is no longer a matter of importance, as the question of renewal of the agreement ceased to concern the trade when it became known officially that the Premier company would continue to uphold prices irrespective of whether the agreement was renewed or not. The first statement of this policy was received in Mr. Busch's cablegram, published last week, but later the Premier Diamond Mining Co. sent messages all over the world, pledging itself not to lower the market price of its precious stones, and throughout the week diamond cutters received individual cablegrams that established this determination unequivocally, and some of them also received cablegrams as to an agreement between the two companies to uphold the market price.

Therefore, at the end of this month either the Syndicate will control the product of all diamond mines of the world, or the situation will be exactly as it was up to October, 1901, and the Syndicate will control the product of the De Beers mines and the Premier stones will be sold independently, but at the same market price as set by the Syndicate. One of the great mistakes which was made by the newspapers, and which they are beginning to appreciate at the present time, lay in the fact that they did not understand that the contract between the Syndicate and the Premier mine had only been in effect since Oct. 1 last, and that even if this was not renewed it would only put matters back to the conditions in which they were before the financial depression began. Another thing the daily papers have begun to appreciate, and that is that the stories from Europe about "breaks" in the diamond market referred to certain drops in quotations of shares of the big diamond companies upon the bourse and stock exchange, and not to the diamonds themselves.

ROCK BOTTOM PRICES ON DIAMONDS

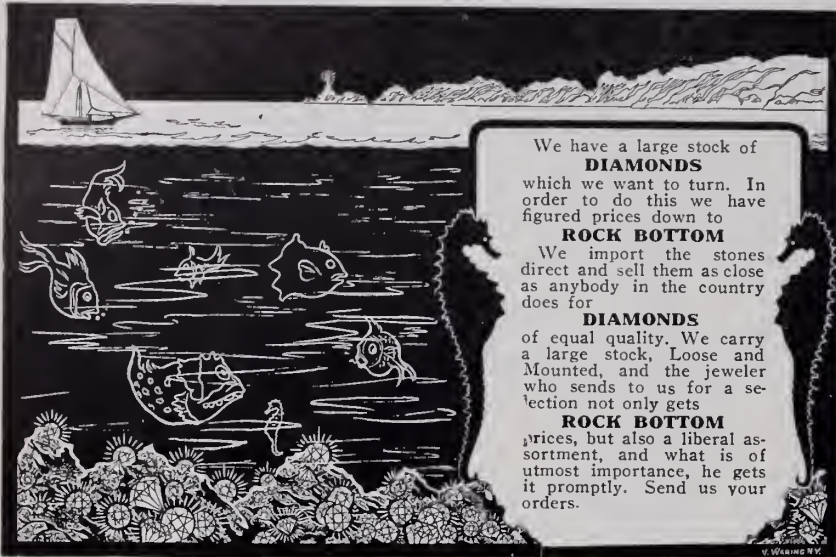

We have a large stock of
DIAMONDS
which we want to turn. In
order to do this we have
figured prices down to
ROCK BOTTOM

We import the stones
direct and sell them as close
as anybody in the country
does for

DIAMONDS
of equal quality. We carry
a large stock, Loose and
Mounted, and the jeweler
who sends to us for a se-
lection not only gets

ROCK BOTTOM
prices, but also a liberal as-
sortment, and what is of
utmost importance, he gets
it promptly. Send us your
orders.

CROSS & BEGUELIN

Importers and Cutters of Diamonds and Precious Stones

40 Rue de Meslay, PARIS

Telephone,
480 John

31 Maiden Lane, NEW YORK



Trade-Mark

OUR guiding principle has always been to incorporate as much artistic skill and good material in the construction of our jewelry as possible. This is contrary to the skimming, economic operations so extensively practiced in the manufacture of inexpensive gold jewelry. In observing this standard we naturally sacrifice the petty profits resulting from the less exacting methods of others; nevertheless our jewelry is consistently low priced and of a quality away beyond the ordinary.

Ask to see it and look for
our trade-mark—the im-
print of originality and
all that's good.

85 Sprague Street
PROVIDENCE, R.I.

H. A. KIRBY

9-11-13 Maiden Lane
NEW YORK CITY

Boston.

William A. Block is on an extended trip in the south.

Edward G. Morris is on a two weeks' trip in Maine.

Joseph Cowan has returned from an extended trip west.

A petition in bankruptcy has been filed against the F. C. Maude Co., of Beverly, Mass.

Buyers in town during the week included: F. P. Fisk, Epping, N. H.; C. A. Senter, Lawrence, Mass.

Creditors of Alvah Skinner & Son received last Saturday a first dividend of 10 per cent. on their claims.

M. Satz, Ware, Mass., is settling with creditors, most of whom are Boston concerns, for 20 cents on the dollar.

David Goldwasser, of the Emblem Jewelry Co., is receiving many congratulations on the advent of a son in his family.

Jacob Rubin will go to Europe shortly, visiting principal cities in England and on the continent, and making a stay of some time at Carlsbad.

Early closing arrangements for the jobbing jewelry trade will be in force from April 1 to Oct. 1, the time being 1 o'clock on Saturdays and 5 o'clock on other days.

Charles D. Tucker, Medford, jeweler and optician, has filed a voluntary petition in bankruptcy. His liabilities are given as \$5,738, of which \$1,900 is secured and \$3,838 is unsecured. His assets are \$1,771.

The annual meeting of the New England Watchmakers' Club was held March 18 at the club's headquarters, 17 Bromfield St., Boston, officers being elected as follows: President, F. J. Whilton; vice-president, W. B. Garfield; secretary, L. M. Coburn; treasurer, L. E. Nichols. The treasurer's report shows a balance on hand of \$475.

Baltimore.

H. Bealmear & Co. have sold out their entire stock at auction, prior to retiring from business. Their store was located at 25 W. Baltimore St., their line being clocks, bronzes, cut glass, silverware and art novelties, both wholesale and retail. Mr. Bealmear had been in business here since July, 1888, being located at 25 S. Charles St. before the fire.

Maurice L. Ruder obtained a verdict of one cent damages in Part 2 of the Court of Common Pleas Wednesday, in his suit against Arthur C. Frey for alleged defamatory language used by Mr. Frey in reference to Mr. Ruder in his business as a jeweler. The trouble occurred in a dispute over a sapphire ring which the defendant bought from the plaintiff.

Edwin F. Bennett, president of the Edwin Bennett Pottery Co. and the Maryland Pottery Co., recently celebrated his 90th birthday. He was born in England and came to this country when a young man, opening a pottery with his brother in Pittsburg. Soon afterward he came to Baltimore and started the Edwin Bennett Pottery, which he has operated for more than 50 years.

U. S. Brumer, De Witt, Ia., recently presented the new library with an eight day clock.

New York Notes.

Mitchell & Tillotson, jewelers' auctioneers, Maiden Lane, are conducting a successful sale for H. A. Hershberger, Johnstown, Pa. W. J. Johnston, of the W. J. Johnston Co., Pittsburg, Pa., was a visitor at the office of THE CIRCULAR-WEEKLY during the last week.

Edgar R. Sparks has gone to San Francisco, where he will assist in looking after the interests of the L. E. Waterman Co. on the Pacific coast.

At the Fifth Avenue Art Galleries during the past week a collection of antique silverware was offered for sale which included a number of pieces of Georgian silver and some old Irish silver.

The Louis Rubin Jewelry Co., New York, was incorporated last week under the laws of the State of New York with a capital of \$2,500. The directors are Louis Rubin, Alexander Bienstock and Samuel Bienstock, all of New York.

The first meeting of creditors of Davis Hayden, 491½ Sixth Ave., was called at the office of Referee William H. Willis, 98 Wall St., last Thursday, at 11.30 A. M., at which time Herman S. Rabinowitz was named as trustee in bankruptcy. A number of creditors filed claims.

W. F. Newhall, of the firm of W. F. Newhall & Son, Lynn, Mass., was a visitor in this city during the past week en route from Bermuda, where he is to spend the spring months. He was accompanied by Fred C. Newhall, Jr., of the firm, who is making purchases in this city for the Spring business.

A meeting of creditors of David Kessler, 26 Henry St., who filed schedules in bankruptcy some time ago, was set down for last Wednesday, at the office of Referee William Miller, 2 Rector St. The bankrupt appeared, but there were no creditors in attendance and the meeting was put over until to-day.

A life-size bronze statue by Fernando Miranda, on exhibition at the Fifth Ave. salesrooms of Tiffany & Co., has attracted considerable attention during the past week. The "Primitive Marksman," as the work is called, shows an Indian holding an immense bow against his feet and aiming, while in a reclining position, at an imaginary soaring eagle.

Harry Levinsohn, formerly a traveling salesman for Freudenheim Bros. & Levy, and who was arrested in Chicago on the charge of stealing jewelry from his employers and returned to New York for trial, was sentenced last Tuesday to a year and even months' imprisonment. He confessed the theft of the jewelry, much of which he had pawned. Part of the pawn tickets have been recovered by the firm.

Included in the list of objects for sale during the last week at the American Art Gallery were potteries and porcelain, among which was a beautiful Amphora vase, six inches in height, of the K'Aug-hsi period 662-1721, which brought the highest price of the day and sold for \$1,775. The grand *ang-de-boeuf* vase, 36 inches high, and a five-colored beaker of the same period together with a soft paste vase were also included in the list of objects sold.

Figures of interest to the trade, according

to the regular monthly statement of the Bureau of Statistics at the Customs House, have just been given out, showing the total value of goods remaining in bonded warehouses at this port for the month ending Feb. 29, among which are clocks, \$23,082, as compared with \$39,856 for the same month last year; watches, \$154,391, as compared with \$77,810 for 1907; diamonds unset, \$69,988, as compared with \$72,381; precious stones, \$3,232, as against \$1,896; and jewelry, \$9,201, as compared with \$9,718.

By a decision handed down last Wednesday, the Board of United States General Appraisers held that rosaries must be dutiable at the rate specified by the provision in the Tariff Act for "beads of all kinds." A protest filed by Benziger Bros., of this city, brought the matter to an issue. Several claims were made by the importers for lower duty, among which was that the merchandise should be permitted to enter this country at 20 per cent. ad valorem under the tariff provision for "unenumerated manufactured articles." The Board, however, finds against the claim of the importers, and the action of the collector in classifying the rosaries at the higher rate is approved.

The board of directors of the Jewelers 24 Karat Club of New York have decided to call a special meeting of the entire membership on Friday evening, April 3, and at the same time hold a beefsteak dinner. It has been arranged to hold the meeting and dinner at Reisenweber's, 58th St. and Eighth Ave., and the meeting will begin at 6.30 P. M. sharp. Business of importance to the club and plans for the Summer outing and the annual banquet will be discussed, after which the dinner will be served. Those present will wear aprons and caps, as is customary at such dinners. It is expected that at least 75 members will attend, and the committee has provided for an entertainment and engaged musical talent for the evening. The beefsteak dinner committee is headed by Chas. F. Brinck; the other members are Chas. R. Jung and M. L. Bowden, Jr.

The bulletin of the Merchants' Association of New York, issued March 17, recommends to the support of the merchants of the country the local parcels post measure endorsed by Postmaster-General Meyer, called the Burnham Senate Bill, 5122, which is to provide for a rural delivery parcels post for merchandize and other articles mailed on rural delivery routes and for other purposes. The bulletin points out that there are now 38,266 rural delivery routes in the United States, over each of which a wagon daily passes and carriers are prohibited by law from carrying anything but mail matter of the various classes prescribed by law, the weight of packages being limited to four pounds. It is the opinion of the Merchants' Association that the provisions of the bill referred to will aid the trade of country merchants by enabling them to make daily deliveries to their local customers at small cost.

There has been on exhibition during the past week at the Fifth Ave. store of the Reed & Barton Co. a magnificent silver service which will be given by the State of Montana to the United States battleship *Montana*, which was launched at Newport

News on Dec. 16, 1906. Historic, scenic and individual features of the State are depicted by pictures included in the designs employed. The service is of massive style and bears the seal of the State and of the Navy Department, and the State flower, the bitter root, is incorporated to a great extent in the detail of the decorative scheme. The entire set is made of native Montana silver and comprises a large punch bowl, plateau, 30 crystal cups, ladle; small punch bowl and ladle, pair of candelabra, two compotiers, two serving trays, two bottle holders, coffee urn and cigar box. A detailed description of this service accompanied by photographs will appear in the next issue of THE CIRCULAR-WEEKLY.

The examination of Louis Halpert, formerly in business at 51 Maiden Lane, and against whom a petition in bankruptcy was filed in January, was continued Monday morning before Referee Smith. The first witness was a representative of Bradstreet's Mercantile Agency, who was shown a statement signed by the bankrupt and he identified it as the one made by Mr. Halpert to the agency. Mr. Halpert was then placed on the stand and examined as to the statements made to "Bradstreet's" and to the Mercantile National Bank relative to his financial condition. He was then asked about the handling of his assets in the Fall of 1907 relative to their conversion into cash. The schedules in bankruptcy were taken up and Mr. Halpert was questioned about the list of men who owed him for merchandize.

A young man who gave the name of George Meyer, and who the police say is George Roberts, alias Charles Martin, whose picture is to be found in the Rogues' Gallery, was held in \$2,000 bail for examination by Magistrate O'Reilly in the Gates Ave. Court, Brooklyn, Tuesday, March 17. He was arrested on Monday afternoon by Detectives Britton and Carr in the store of Jules A. Piccard, 1233 Fulton St., where he had been locked in by the proprietor after he had been caught, it is alleged, in the act of concealing a \$20 gold watch chain. When the prisoner was taken to the police station he was recognized by Captain Thomas J. Kelly as a man who had been in trouble with the department before. The prisoner asserted that a mistake had been made and that he was an electrician and lived with his mother at 250 Ridge Ave. The capture of the man was due to the cleverness of the jeweler. The man entered the store and asked to look at some gold watch chains. Joseph Knowles, a salesman, was about to attend to the wants of the stranger, but Mr. Piccard, the proprietor, thought that something was wrong and said that he would be at liberty in a moment to show the watch chains. The chains were displayed for his selection and the young man took up one of the chains in his hand, and concealing it, caught up another. He placed the last chain across the front of his vest and turned his back to the proprietor, pretending to be looking in the mirror to get the effect. The jeweler observed what was going on and got out from behind the counter between the young man and the door, and then locking the door, summoned the police. When the prisoner was brought

ESTABLISHED 1852

THE NASSAU BANK

Original Clearing House Member

Corner Nassau and Beekman Streets - - - - NEW YORK

Title Guarantee and Trust Company 176 Broadway (between John St. & Maiden Lane) NEW YORK

Capital and Surplus, \$12,000,000 :: The Depositor's best guarantee is a large capital and surplus, together with conservative management

TRUSTEES

John Jacob Astor, 23 West 26th St., New York
 Frank Bailey, Vice-President
 E. T. Bedford, President Corn Products Refining Co.
 Charles S. Brown, of Douglas Robinson, Charles S. Brown & Co.
 Julien T. Davies, of Davies, Stone & Auerbach
 William M. Ingraham, Attorney-at-Law, 44 Court St., Brooklyn
 Augustus D. Juilliard, of A. D. Juilliard & Co.
 Martin Joost, Vice-President Bond & Mortgage Guarantee Co.
 Clarence H. Kelsey, President
 John S. Kennedy, Retired, 31 Nassau St., New York
 Woodbury Langdon, of Joy, Langdon & Co.
 James D. Lynch, Retired, 129 East 21st St., New York
 Ranald H. Macdonald, of R. H. Macdonald & Co., Real Estate
 James H. Manning, President National Savings Bank, Albany
 Edgar L. Marston, of Blair & Co.

Wm. J. Matheson, of W. J. Matheson & Co., 182 Front St.
 Charles Matlack, 70 State St., Boston
 William H. Nichols, Chairman of Board, General Chemical Co.
 William A. Nash, President Corn Exchange Bank
 Robert Olyphant, of Ward & Olyphant
 Charles A. Peabody, President Mutual Life Insurance Co.
 William H. Porter, President Chemical National Bank
 Frederick Potter, 71 Broadway, New York
 Charles Richardson, 1307 Spruce St., Philadelphia
 Henry Roth, 1562 Myrtle Ave., Brooklyn
 Jacob H. Schiff, of Kuhn, Loeb & Co.
 James Speyer, of Speyer & Co.
 Sanford H. Steele, of Steele, Otis & Hall, Attorneys
 Ellis D. Williams, 560 Drexel Bldg., Philadelphia
 Louis Windmuller, of Louis Windmuller & Roelker

BRANCH BANKING OFFICES: 196 Montague St. and 175 Remsen St., Brooklyn; 350 Fulton St., Jamaica; 67 Jackson Ave., Long Island City

The Market and Fulton National Bank of New York

ORGANIZED 1852

81-83 FULTON STREET

Capital, \$1,000,000

Surplus, \$1,500,000

PROGRESSIVE—CONSERVATIVE—SUCCESSFUL

ALEXANDER GILBERT, President
 R. A. PARKER, . . . Vice-President
 T. J. STEVENS, Cashier
 JOHN H. CARR, . . . Asst. Cashier

Invites the Accounts of Jewelers

Will extend every facility that good banking will justify

SAFE DEPOSIT VAULTS

THE STATE BANK

376-378 GRAND STREET, NEW YORK

Capital and Earned Surplus, over \$1,500,000. Deposits over Fifteen Millions
 Offers a favorable market for short and long time jewelry and diamond paper.

The Mercantile National Bank

OF NEW YORK

WILLIS G. NASH, President

MILES M. O'BRIEN, Vice-President

WM. SKINNER, Vice-President

WILLIAM H. TAYLOR, Vice-President

EMIL KLEIN, Cashier

DIRECTORS

WILLIAM F. CARLTON,
ROBERT C. CLOWRY,
WILLIAM NELSON CROMWELL,
L. H. CUTTER,
EDWIN GOULD,
HAROLD A. HATCH,

EDWARD T. JEFFERY,
WILLIAM H. LAWS,
WILLIS G. NASH,
BENJAMIN NICOLL,
MILES M. O'BRIEN,
CHARLES E. PERKINS,

DICK S. RAMSAY,
WILLIAM SKINNER,
E. D. STREET,
WILLIAM H. TAYLOR,
E. J. TRUSSELL,
WARNER VAN NORDEN,

Strictly a Commercial Bank
Accounts Solicited

1851

The Jeweler's Bank for half a century
in the same location.

1908

THE
CHATHAM NATIONAL
BANK

Broadway and John Street, New York

ACCOUNTS INVITED

GEORGE M. HARD, President

WILLIAM H. STRAWN, Cashier

HENRY L. CADMUS, Assistant Cashier

== TRADE - MARKS ==

Manufacturers and Jobbers :

We now have in preparation a supplement to the second edition of "*Trade-Jewelry and Kindred Trades*," and in order that it may be as complete and accurate as to new marks as it is possible to make it, we request every manufacturer and jobber to send us a list of such marks as he may *now use*, or *has ever used*, together with such information (the kind and quality of goods upon which the marks are used, etc.,) as may be germane to the subject. Send cuts of marks if possible. If not, send clear, printed impressions or drawings.

The earliest attention is solicited, as it is of utmost importance to every manufacturer and jobber to have his mark recorded in this supplement.

THE JEWELERS' CIRCULAR PUBLISHING CO.

11 John Street, NEW YORK

New York Notes.

(Continued from page 67.)

into court he pleaded not guilty and asked for time to employ counsel.

Armond E. Braden, for the past 18 months in the employ of R. Blackinton & Co., 3 Maiden Lane, is no longer with that concern.

C. M. Robbins, of the C. M. Robbins Co., Attleboro, Mass., is spending a few days in town. He has just returned from the south.

A. Ludwig, of A. Ludwig & Son, 75 Nassau St., who has been sick for some time at St. Luke's Hospital, has been removed to his home.

Moe Adels, of the firm of M. Adels & Co., 35 Maiden Lane, was married on Thursday, March 19, to Miss Maude R. Levy, of Alliance, O.

Alex. Salsevitz, of the firm of Salsevitz Bros., 115 E. Broadway, celebrated the 10th anniversary of his wedding Sunday evening at his home, 1418 Pitkin Ave., Brooklyn. Mr. and Mrs. Salsevitz received the congratulations of about 70 friends who gathered to celebrate the occasion.

A hearing in the matter of the confirmation of the composition settlement offered by Adolph L. Hodes, 65 Nassau St., against whom a petition in bankruptcy proceedings was filed some time ago, will be held before United States District Judges in the Post Office building, next Monday at 10.30 a. m. The offer of settlement is 50 cents on the dollar; 10 cents in cash and the rest in notes.

F. A. Croselmir, formerly of the Croselmir & Ackor Co., platinum, gold and silver refiners, Newark, N. J., is now manager of the platinum department of the Roessler & Hasslacher Chemical Co., 100 William St. The plant of the Croselmir & Ackor Co. has been purchased by Franz Eisenbach & Co., the home address of which firm is Offenbach, Germany. Messrs. Croselmir & Ackor have both withdrawn from the concern.

The new Silversmiths' building, 15, 17, 19 Maiden Lane, will be ready for occupancy May 1, 1908. The building is equipped with every modern convenience. The following firms have already engaged quarters in the new building: Aikin, Lambert Co., H. F. Barrows Co., Barrett, Nephews & Co., R. Blackinton & Co., Bliss Bros. Co., D. D. Brokaw, J. B. Bowden & Co., Bruhl Bros. & Henius Co., O. M. Draper Estate, Wm. B. Durgin Co., Elgin National Watch Co., Ford & Carpenter, Gorham Co., H. E. Heacock, W. S. Hicks' Sons, Himalaya Mining Co., Wm. B. Kerr Co., Mabie, Todd & Co., Marden & Kettley Co., Charles Marx, M. A. Mead & Co., Jewelers' Board of Trade, Chas. M. Robbins Co., Standard Button Co., Silversmiths' Co., Towle Mfg. Co., L. Tannenbaum & Co., Union News Co., Isaac H. Weinberg, William Bros. Mfg. Co., Weiner, Garson & Naigles, Whiting Mfg. Co., Charles F. Wood & Co. The International Silver Co. are to occupy the third floor in this building, in addition to their present quarters. The Whiting Mfg. Co. will have show rooms in the building, in addition to their uptown store. Booths in the arcade will be occupied for

the sale of periodicals, confectionery and cigars. Bootblack and barbershop establishments will also be located in the arcade, which connects John St. and Maiden Lane.

Demurrer and Exceptions Filed to Bankruptcy Petition Against M. C. Dreshfield and Geo. H. Carpenter.

Exceptions and a demurrer have been filed by Irving M. Dittenhoefer, attorney for Maurice C. Dreshfield, a diamond dealer, 170 Broadway, New York, and George H. Carpenter, a manufacturer of fire appliances, 17 E. 32d St., New York, in answer to the petitions in involuntary bankruptcy filed in the United States District Court, March 11, which allege that \$182,000 worth of diamonds were obtained from Rudolph A. Breidenbach, a precious stone importer of New York, upon alleged fraudulent statements made by him. The demurrer states that certain allegations in the petition do not state facts sufficient to constitute any acts of bankruptcy. The exceptions are upon the ground that the allegations are scandalous and irrelevant to any issue to be determined in the case. Judge Holt heard argument on the demurrer and decision was reserved.

A petition in bankruptcy has been filed in Connecticut against the Monarch Corporation, manufacturing fire extinguishers at Bridgeport, whose office is at 17 E. 32d St., New York. Geo. H. Carpenter is president of the corporation.

Miss Maude L. Moylan, private secretary to George H. Carpenter, was examined Tuesday, March 17, before United States Commissioner Alexander in the bankruptcy proceedings against Carpenter. She did not give any information relative to what disposition Carpenter made of the money obtained on the diamonds secured from Mr. Breidenbach.

There was a conference of creditors of Mr. Breidenbach last Thursday at the office of Oppenheimer Bros. & Veith, at which time Mr. Breidenbach made a statement of his financial condition, which established his solvency beyond question, showing, as it did, liabilities of \$198,000 with assets of \$449,000, which includes real estate, stock and bills receivable. Hays & Hershfield represented the creditors and Sol Oppenheimer was present for Mr. Breidenbach.

Trans-Atlantic Voyagers.

TO EUROPE.

C. W. S. Reinhardt, Providence, R. I., sailed for Europe, last week.

Mr. and Mrs. F. B. Reynolds, Providence, R. I., sail to-day on the *Adriatic*.

Jos. L. Sweet, of the R. F. Simmons Co., Attleboro, Mass., sailed, recently, for Italy.

J. C. Manheimer, of Louis Manheimer & Bros., Chicago, sails next Tuesday, on the *Hamburg*.

E. B. Shepherd, with Albert Lorsch & Co., Providence, R. I., sailed Saturday on the *Lusitania*.

The store of the West Texas Jewelry Co., Abilene, Tex., was damaged during a recent fire at that place.

Last Week's New York Arrivals

THE CIRCULAR-WEEKLY each day posts in its office a bulletin of the latest buyers visiting New York, which every member of the trade is cordially invited to copy.

- ALTOONA, PA., J. Weygandt (Kline Bros.), 214 Church St.
- ATLANTA, GA., J. P. Edwards (W. R. Edwards & Co.), Astor House.
- BALTIMORE, MD., L. Kann, Hoffman House. J. Levi, Breslin.
- BOSTON, MASS., J. C. Sawyer, Broadway Central.
- CLEVELAND, O., S. W. Gerhart (The Bailey Co.), Hoffman; 805 Broadway.
- CORNING, N. Y., J. W. Fedder, Broadway Central.
- DARLINGTON, S. C., S. Wolfram, Herald Sq.
- GRAND RAPIDS, MICH., G. A. Smith, Broadway Central.
- HARTFORD, CONN., P. H. Stevens, Grand.
- PHILADELPHIA, PA., Mrs. M. W. Boyd (Lit Bros.), Imperial; 685 Broadway.
- PITTSBURG, PA., A. M. Andrews, Netherland. W. J. Johnston (W. J. Johnston & Co.), Waldorf.
- PROVIDENCE, R. I., A. J. Ferguson (Callender, McAustin & Troup Co.), 2 Walker St.
- SPRINGFIELD, MASS., Mrs. G. B. Pierce (Smith & Murray), 55 White St.
- WASHINGTON, D. C., A. Rosenthal (M. Goldenberg), Grand; 65 Bleecker St.
- WORCESTER, MASS., A. J. Moir (J. C. McInnes & Co.), Waldorf; 55 White St.

Syracuse.

The Morse Optical Co. has elected the following officers: President and treasurer, James H. Morse; vice-president, F. M. Newton; secretary, I. V. Tomlin.

Calvin S. Ball, of this city, celebrated his 76th birthday Wednesday last at 129 Seymour St. He celebrated his 50th anniversary in the jewelry business in March, 1902.

The Dey Time Register Co. recently sued the Standard Electric Time Co. for breach of contract and the defendant moved to set aside service of the summons, which service was made upon a salesman in New York. It was claimed that the salesman was manager of the concern. The suit is for alleged failure of the defendant to connect 70 clocks with an electric arrangement.

Harrisburg, Pa.

The Huntingdon Business Men's Association banquetted March 19.

Charles Boyer will shortly open a store in East Berlin, Adams county.

F. M. Chritzman, of this city, and traveling salesman for the Rockford Silver Plate Co., is a Republican candidate for county treasurer.

City councils have passed an ordinance appropriating \$200 for the proper placing of the bronze lamp, given by the National Humane Alliance, New York, over a drinking fountain at Derry and Mulberry Sts.

Savannah, Ga.

Capt. A. J. Benkel, retired, of Augusta, Ga., has been tendered the captaincy of the Oglethorpe Infantry of that city.

S. E. Theus, of Theus & Co., was a member of the entertainment committee of Alec Temple, Mystic Shriners, appointed to entertain Illustrious Imperial Potentate Frank C. Roundy, of Chicago, during his recent visit here.

The Silversmiths' Building

15-17-19 MAIDEN LANE

EDWARD HOLBROOK, President

IN the center of the wholesale jewelry and silverware trade of this Continent. The largest, best situated and finest building in the world, erected for the occupancy of jewelry, silverware and kindred trades. Maximum daylight in all parts of the building; north, east and south light. Architecturally, the most beautiful building devoted to this trade. The building is equipped with 7 of the latest fast-running type of Otis Traction Elevators. Vacuum Cleaning System installed on every floor. Ready for occupancy May 1st.

FOR PLANS AND PARTICULARS, APPLY TO
GROSS & GROSS COMPANY, Managers
 COURTLAND E. HASTINGS, Agent
 171 Broadway, Room 5

Entire floors, large suites and offices have been leased to tenants for a long term of years, among whom are



Aikin-Lambert Company
 Barrett, Nephews & Co.
 Barrows, H. F., Company
 Blackinton, R., & Co.
 Bliss Brothers Company
 Block Bros.
 Bowden, J. B., & Co.
 Brokaw, D. D.
 Bruhl Bros. & Henius
 Draper, Estate of O. M.
 Durgin, Wm. B., Company
 Elgin National Watch Company
 Ford & Carpenter
 Gorham Company, The
 Heacock, H. E.
 Hicks', W. S., Sons
 Himalaya Mining Company
 International Silver Company
 Jewelers' Association and Board of Trade
 Kerr, Wm. B., Company
 Mabie, Todd & Co.
 Marden & Kettlety Company
 Marx, Charles
 Mead, M. A., & Co.
 Queen City Silver Company
 Robbins, The Chas. M., Company
 Silversmiths Company, The
 Standard Button Company
 Tannenbaum, L., & Co.
 Towle Manufacturing Company
 Union News Company
 Weinberg, Isaac H.
 Weiner, Garson & Naigles
 Whiting Manufacturing Co.
 Williams Brothers Mfg. Company
 Wood, Charles F., & Co.

Handsomely ornamented booths in the Arcade will be occupied for the sale of Periodicals, Confectionery, Cigars. Also Bootblack and Barber Shop Establishments.

The International Silver Company are to occupy the third floor in this building in addition to their present quarters. The Whiting Manufacturing Company will have showrooms in this building in connection with their uptown store.



W. Lamb, of Geo. H. Fuller & Son Co., Chicago, is now in San Francisco, Cal.

Mr. Hovey, with J. B. Whitney & Co., San Francisco, Cal., has just returned from Seattle, Wash.

Mr. Wolfsheim, of Wolfsheim & Saehs, New York, has just left San Francisco, Cal., for the east.

Traveling representatives in Los Angeles, Cal., last week, were: Milton O. Kepler, Powers & Mayer; S. K. Jonas.

C. Hanni, with Sussfeld, Lorsch & Co., New York, has just left San Francisco, Cal., for a visit to other parts of the coast.

Leland Myers, of the R. & L. Myers Co., San Francisco, Cal., has returned from a trip through southern California and the San Joaquin valley. He leaves in a few days for Portland, Ore.

Among the travelers who called on the trade in Williamsport, Pa., last week, were: Francis Prity; Alex. Patterson, Smith & North; Fred Eaton, N. H. White & Co.; Mr. Moore, Wilcox Silver Plate Co.

Traveling representatives who were in Denver, Colo., last week, included: Louis Freund, Henry Freund & Bro.; O. T. Samuelson, Towle Mfg. Co.; Theo. Kuehl, George Kuehl & Co.; L. Wolfsheim, Wolfsheim & Saehs; T. H. Donnelly, Sprochnle & Co.; Ben Speer, Speer & Co.

Among the traveling representatives who called on the trade in Indianapolis, Ind., last week, were: H. P. Lanz, Aikin-Lambert Co.; John Hoagland, F. T. Pearce Co.; Ernest A. Rose, Weigle & Rose; Samuel J. Loeb, representing a number of jobbers and manufacturers: A. L. Haneock, C. Sydney Smith & Co.

The following traveling representatives were in Cleveland, O., during the past week: Jules Franklin, Jules Franklin & Co.; Mr. Davidson, Kohn & Co.; Walter Shute, Day, Clark & Co.; Mr. Dean, Reed & Barton; Mr. Higham, Alling & Co.; Mr. Van Bergh, Van Bergh Silver Plate Co.; J. L. Shepherd, Keystone Watch Case Co.; J. W. Ambroster, Illinois Watch Co.

Traveling men visiting Boston, Mass., during the week included: E. Cooper Stone, Jones & Woodland Co.; Cyrus Priece; Mr. Davidson, Wallach & Davidson; Joseph Rosenberg; Joseph Fleishner, Hirsh & Fleishner; Howard Deutseh, Jennings, Lauter & Co.; Charles B. Burgess, Frank M. Whiting & Co.; L. Henry Jurgens, Snow & Westcott; John F. Schierloh, Keystone Watch Case Co.; E. V. Hutton, H. & E. O. Belais.

The following traveling representatives have been in Savannah, Ga., recently: John A. Abel, Abel Bros. & Co.; Frank P. Steitz, William Link, Chas. Sonfield, C. Bruns & Son; Charles H. Horton, Bradley & Hubbard Mfg. Co.; A. M. Haring, Carter, Howe & Co.; Wm. Kinserherf, Jr., William Kinserherf Co.; Charles Stiner, Louis Adler & Son; Mr. Richardson, William B. Durgin Co.; C. V. Sehuyler, William B. Kerr Co.

The following traveling representatives visited the trade in Lancaster, Pa., recently: Walter S. Strauss, Jacob Strauss & Sons; Mr. Levy, Bristol Mfg. Co.; Charles B. Smith, M. B. Bryant & Co.; C. G. Cushman, Reed & Barton; L. H. Green, Manchester-Smith Co.; Leon K. Beidler, B. F. Williams Co.; John T. Vansant, Moore & Sons; William A. Lamb, West Silver Co.; Sol. Siekles, M. Siekles & Sons; Morris Freedman, M. Freedman & Co.; J. R. Reidel, Oneida Community, Ltd.

The following traveling representatives called on the trade in Kansas City, Mo., during the past week: John F. Garland, Keller Jewelry Mfg. Co.; Joe Frank, Sussfeld, Lorsch & Co.; Alfred H. Baer, Attleboro Chain Co.; Mr. King, Ostby & Barton Co.; Max J. Jaoby, Manchester Mfg. Co.; Henry E. Hart, Albert Lorsch & Co.; Joseph O. Otis, Harvey & Otis; Frank W. Bloomer, E. I. Franklin & Co.; G. A. Armstrong, Paye & Baker Mfg. Co.; H. S. Noyes, Bates & Bacon; H. A. Seofield, Seofield, Melcher & Seofield; John A. Davis, Wm. Rogers Mfg. Co.; David Fox, I. Guntz & Son; Mr. Pay, T. I. Smith Co.

Traveling salesmen who called on the Cincinnati,

O., trade, during the past week, included: Leo Cain, Borrelli & Vitelli; George W. Beardsley, Allsopp & Allsopp; J. F. Dean, Reed & Barton; Charles B. Evans, John R. Keim; H. B. Bliss, Gorham Co.; William Mateschke, A. Joralemon & Son; Millard E. Heise, Langfeld Bros. & Co.; Mr. Hartshorn, Kremenitz & Co.; H. W. Stevens, Bay State Optical Co.; Donald Le Stage, H. D. Merritt & Co.; Frank J. Ryder, Walter E. Hayward; H. F. Tourtellot, Waite, Thresher Co.; Robert B. Steele, David Kaiser & Co.; C. A. Holbrook, Sloan & Co.; C. Glander, J. D. Dalzell & Co.; A. H. Oakley, Thornton Bros. Co.; Charles H. Clark, W. G. Clark Co.

Traveling representatives who called on the trade in Omaha, Nebr., the past week, included: W. S. Willis, Gorham Co.; Reuben W. Cohen, George H. Caboon Co.; Thomas H. Ryland, American Watch Case Co.; J. A. Crawford, J. W. Forsinger; William Strauss, Louis Kaufman & Co.; F. F. Gibson, Gibson, Krugler Co.; David Fox, I. Guntzburger & Son; A. Pretzfelder, L. W. Levy & Co.; Thomas E. Rogers, Riker Bros.; F. J. Neasham, C. H. Knights & Co.; E. E. Spaulding, Allsopp Bros.; a representative of the Basset Jewelry Co.; Harry Goodison, E. G. Webster & Son; O. W. Heinz, Heinz Bros. Cut Glass Co.; Thomas H. Batcheller, Moore & Son; A. S. Wormwood, Illinois Watch Co.; a representative of Joseph Fahys & Co.; E. C. Binder, Ernst (Gideon) Bek; A. A. Brecker, W. A. Pickard Co.; W. S. Dudley, International Silver Co.; G. Glenn Steel, Rogers, Lunt & Bowlen Co.; a representative of the Warner Mfg. Co.; J. H. Mednikow, J. H. Mednikow & Co.; Charles Dispeker, Ritter, Kahn & Co.; Henry Sherrill, Sinnock & Sherrill; Mr. Raymond, Worthington & Raymond; C. A. Wilkinson, Jr.; C. A. Wilkinson; M. Blinker, T. G. Hawkes & Co.

Among the traveling representatives who visited the trade at Pittsburg, Pa., recently, were the following: J. F. Dean, Reed & Barton; W. F. Joel, E. H. H. Smith Silver Co.; S. E. Coggins, Towle Mfg. Co.; Chas. T. Dougherty, Osmers-Dougherty Co.; William Mateschke, A. Joralemon & Son; Robert F. Steele, David Kaiser & Co.; John S. Cunningham, E. L. Spence Co.; J. W. McClannin, Wilcox Silver Plate Co.; Mr. Ford, Ford & Carpenter; Mr. Sweet, J. F. Sturdy's Sons; Chas. H. Clark, W. G. Clark & Co.; Fleetwood Lanneau, R. Blackinton & Co.; Mr. Crane, Mandeville, Carrow & Crane; DeForest Fly, Barbour Silver Co.; Mr. Hull, Barden & Hull; C. B. Bartlett, Whiting Mfg. Co.; S. C. Corbin, Waterbury Cloek Co.; A. J. Sherrard, Enos Richardson & Co.; Mr. Curran, A. J. Hedges & Co.; Joseph A. Sideman, Redlich & Co.; Mr. Anderson, Langfeld Bros. & Co.; Joseph Hurd, William S. Pitcairn; A. H. Oakley, Thornton Bros. Co.; J. Williams, Fera & Kadison; M. E. Van Bergh, Van Bergh Silver Plate Co.; S. Englander, Van Antwerpen, van den Bosh & Co.; Frank J. Ryder, Walter E. Hayward Co.; E. A. Reed, Reed & Barton; D. Skuteh, New Haven Cloek Co.; M. Loeh, Dueber-Hampden Watch Works; Mr. Bennett, Waite, Mathewson & Co.; J. E. DeWyngaert, Scofield & DeWyngaert; Donald Le Stage, H. D. Merritt Co.

News Gleanings.

The building occupied by the Scott Co., Goodland, Kans., was recently destroyed by fire.

The E. L. Deacon Jewelry Co., Denver, Colo., has engaged the services of E. F. Hall, who has been covering the northwest for a number of years, in order to give E. L. Deacon more time for his nearby trade.

Calvin Paterson, for the past two years in the employ of J. C. Keith, Ellwood City, Pa., died recently at the Mercer Hospital of a complication of diseases. The deceased was 42 years of age. He is survived by a widow and two small children.

Philip Stern, a cripple who for many years sold jewelry on St. Charles St., near Canal St., New Orleans, La., died recently. The deceased was a native of Holland and had been a resident in New Orleans for 13 years. He was 60 years old, was married twice and is survived by a widow and four children.

Among the supplies called for by the purchasing agent of the Post Office Department, bids for which will be opened on April 15, are 12,000 dials, to be made of pyralin, celluloid or other suitable material, to be 15/16 inch diameter, 1/8 inch thick, numbered on the edge from 0 to 9, inclusive. A dial giving a good idea of what is wanted will be furnished by the department to any prospective bidder.

Mrs. Mary F. Wolf, widow of the late George Wolf, of George Wolf & Co., Louisville, Ky., died March 9 in her 66th year. The deceased was born in Louisville and was widely known in this city for her many lovable traits as well as her many kindnesses. The jewelry business which her late husband established in 1856 she continued at his death, and of late years has been under the management of her two sons, George W. and Albert A. Wolf. William D. Wolf has been appointed in her will as administrator of the estate.

Jacob Muhr, formerly one of the best known jewelers of the east, and long president of the old house of H. Muhr Sons, Philadelphia, who died about two years ago, leaving a large estate, was a bachelor, and did not clandestinely wed Mrs. Florence Leggett, according to a decision rendered, Monday, by Judge Lamarelle, of the Orphan's Court, Philadelphia. It will be recalled that Mrs. Leggett put in a claim to a widow's dower after the death of Mr. Muhr, and her claim was bitterly contested by the Muhr family. The testimony in the case was spicy and the trial lasted about two weeks, during which witnesses were summoned from New York, Pittsburg and other cities, to testify as to the relations existing between Jacob Muhr and Mrs. Leggett. Under the decision, Fanny Muhr, sister, and Philip Muhr, a brother, formerly also with H. Muhr Sons, later in the smelting business, but now a portrait painter, and nephews and nieces, will divide between them about \$200,000 of the late Jacob Muhr's estate. Mrs. Leggett gets nothing from the estate.

Mrs. Marion M. Sargeant, wife of Frederick E. Sargeant, late cashier of the Jewelers' National Bank, N. Attleboro, Mass., who committed suicide recently, has filed an answer in the suit brought by Charles D. Bancroft, the receiver of the bank for the recovery of money which the receiver claims was turned over by the dead cashier to his wife. In her answer Mrs. Sargeant says that between May 16, 1904, the year in which she was married to Mr. Sargeant, and Dec. 17, 1907, the date of his death, she received from him moneys and checks amounting to \$67,883.51, and that this amount was deposited at different times in the Old Colony Trust Co., in Boston, in her name. Of that sum, the answer says, she used \$884.71 for her personal needs and \$2,172 for household and incidental expenses. At the direction of Mr. Sargeant, the answer says, she checked to him and to others at his direction sums amounting to \$64,618.54. The answer says that the defendant will neither admit nor deny that Mr. Sargeant misappropriated funds. It is denied, however, that Mrs. Sargeant had any knowledge of any misappropriation. The answer was returned in the Middlesex County Court in Cambridge.



GNTERPRISING and successful jewelers everywhere are pushing the sale of some individual line of watches which they believe to be superior to all others, and upon which they can also make a satisfactory and justifiable profit.

This explains the growing demand for ILLINOIS WATCHES, in 0, 12, 16 and 18 sizes, by increasing numbers of leading jewelers throughout the United States.

If you are not familiar with the superior quality of—and advantages gained by handling—Illinois Watches, it will mean reputation and dollars for you to investigate.

Every one fully guaranteed.

Price List sent on application.

ILLINOIS WATCH COMPANY

SPRINGFIELD

CHICAGO AND WEST

Western Office:
501 HEYWORTH BLDG., 42 E. Madison St.,
CHICAGO.

Telephone:
5125 CENTRAL,
CHICAGO.

L. LVI.

CHICAGO, WEDNESDAY, MARCH 25, 1908.

No. 8.

Chicago Notes.

Katlinsky has served two weeks on the bench in the Circuit Court.

Geo. Sheehan, buyer for Chas. A. Tucker, Lincoln, Nebr., was here last week.

The Bauman Loan Co., 159 S. Clark St., will remove, May 1, to 110-112 Madison

Walter C. Saff, jewelry buyer for Louis Haber & Co., celebrated his wooden wedding March 15.

Claude Seymour, of Otto Young & Co., accompanied by Mrs. Seymour, is on a trip to New Orleans.

A. G. Larsen, with the Julius King Optical Co., is the proud father of a new baby girl, born on March 16.

R. B. Bruening, with the Schrader-Altstern Co., has returned from a three months' tour of Europe.

Louis Bruns, the far western representative of the Juergens & Andersen Co., spent a few days here last week.

V. H. K. Dowse, president of Reed & Barton, was here last week visiting H. M. Lee, Chicago, manager of the concern.

Harry Hahn will be chairman of the committee on jewelry and kindred lines for the Chicago Association of Commerce for 1908.

Harry H. Miller, who represents Hutchins & Huestis, received a new line of interchangeable initial and emblem rings last week.

Harry W. Yaseen, Dalhart, Tex., was a visitor here last week. Mr. Yaseen will shortly open a branch store at Tucumcari, Mex.

Mrs. J. H. Booth, Miss Babe Booth and little "Johnny" Booth, of the family of H. Booth, Alton, Ill., were here last week on their way east.

The stock of Sigmund Ascher, bankrupt, was sold at auction last week and realized \$178. Ascher's liabilities are \$3,832. E. D. Bell was appointed trustee.

C. Manheimer, of Louis Manheimer & Sons, accompanied by his wife, will sail for Europe on March 31 on the *Hamburg* for a six months' European tour.

Among the buyers in town last week were Arthur Rovelstad, Elgin, Ill.; Cliff Sherman, Woodstock, Ill.; Palsted, Milwaukee, Wis., and E. C. Zimmerman, La Salle, Ill.

Mortimer Adler, of Chas. Adler's Sons, was hurriedly called home last week on the sad news of his father's death, receiving the condolences of his many friends here.

Commencing with the first Saturday in April the wholesale jewelry trade of Chicago will close at 1 o'clock on that day during the months of April, May, June, July and August.

Samuel Cutler, S. Mills' retail jeweler, 109 Van Buren St., and W. A. Burrows, jobber, in the Hayworth building, have been appointed appraisers of the assets of the Shourds-Adcock-Teufel bankrupt estate.

Mortimer Strasburger, European partner of Louis Strasburger's Son & Co., and who has not been in America for 20 years, was here last week on a visit to Sol Kaiser. Messrs. Strasburger and Kaiser are now in New York.

S. T. A. Loftis, while taking a vacation at Hot Springs, Ark., was thrown from the horse he was riding and was very painfully injured. Mr. Loftis is now in a hospital at Hot Springs and is reported on a rapid road to recovery.

News was received here last week that in the conflagration which destroyed five business blocks in Big Timber, Mont., the retail jewelry store of W. P. Mulholland was destroyed, with a total loss of \$5,000. The insurance is \$1,600.

Chas. A. Nolting, of the Oskamp-Nolting Co., Cincinnati, O., brought his daughter here last week to undergo an operation, which was successfully performed. Mr. Nolting left for home Saturday, leaving Miss Nolting in the hospital here.

Florence Haber, wife of C. F. Haber, of the traveling force of the Towle Mfg. Co., died at Englewood Hospital last week, after undergoing an operation. The interment was at Rose Hill Cemetery. Friends in the trade extend their sympathy to Mr. Haber in his bereavement.

The old jobbing house, the F. C. Happel Co., is in financial difficulties and are seeking to compromise with creditors at 50 cents on the dollar. The concern owes about \$60,000. Nothing but sympathy is expressed for this firm, which is one of the oldest jobbing jewelry houses in the west.

The "Camels" held their regular monthly dinner at Gallis' last Thursday, with Harry E. Jones in the chair. J. W. Tire and R. S. Church were initiated. The following new members were proposed and accepted: Albert M. Dueber, Dan. W. Douglass, Frank Plon, Henry Pfordresher and Finley M. Drummond.

The Madson-Steele Co.'s assets will probably be sold this week. The appraiser's report show the estate to be worth \$12,768.

Of this amount the stock and fixtures are estimated to be worth \$8,827. The 12,000 names are estimated worth \$600 and the book accounts, face value, \$10,000, are estimated worth \$3,100.

S. H. Hess won the *Evening Journal's* prize, last week, for the best contribution on "Mental Telepathy." Mr. Hess related that some time ago his valuable collie dog, "Colleen," was lost. He inserted a "lost" ad. that afternoon in several papers and returned home. He found the dog sitting on the doorstep, and felt convinced that by mental telepathy "Colleen" knew her loss was being mourned.

William F. Zibell has been appointed trustee for the bankrupt estate of Giovanni Faraco, a jeweler at 241 Milwaukee Ave. The assets are claimed to be worth \$3,386. The liabilities are \$4,660. He owes the following firms for jewelry: A. C. Becken Co., \$317; Emil Braude & Bro., \$503; N. S. Herzog, \$231; S. Lazarus & Co., \$286; B. Schuette, 208; Sproehle & Co., \$152; Swartchild & Co., \$118; Albert M. Johnson, \$438; S. Buchsbaum & Co., \$46; I. Castagnetti & Son, \$152; H. Davidson, \$65; Gilbert Clark Co., \$35; Chas. H. Levy, \$105; Otto Young & Co., \$71; A. Hirsch & Co., \$51; Despres, Bridges & Noel, \$10.

Toledo.

William F. Broer, secretary-treasurer of the Merrill, Broer Co., wholesale jewelers in the Smith & Baker building, has just returned from a month's trip to Florida. Mr. Broer states that since the middle of this month business has been improving.

J. J. Freeman & Co. have just been awarded the contract to furnish the silverware for the new Hotel Secor, of this city, the contract price being about \$12,000. The Daudt Glass Co. has also received the contract to furnish chinaware to the extent of \$3,600 and glassware worth \$3,000. Wallick Bros., New York, are lessees of the hotel, which will be opened about mid-Summer.

Diamonds valued at \$1,200 were stolen recently from the store of J. F. Higginbotham, Brandon, Man., while the proprietor was at lunch.

The G. H. Geer Jewelry Co. was recently incorporated in Memphis, Tenn., with a capital of \$3,000. The incorporators were: G. H. Geer, J. H. Collins, C. E. Griffin and D. F. Barnwell.

Would You—If You Could—Increase Your Business 50^{Per} Cent.?

**We Can Tell You How To Do It—In a Dignified, Simple Way
With a High Grade Catalog of Your Own**

**WRITE US FOR
PARTICULARS**



STORE OF CADY & OLMSTEAD JEWELRY COMPANY, KANSAS CITY, MO.

(Copy of letter)

The Arnstine Bros. Co., Cleveland, O.

Kansas City, Mo., Jan. 10, 1908.

Gentlemen:—Your letter of the 4th received, asking our opinion of the Catalogues you issued for us, this being the fourth season. We were very well pleased with the way they were gotten up.

The illustrations were good, especially the colored pages.

The results we got were satisfactory, considering the time they were mailed out. We were late in placing the order; therefore late in getting our Catalogues.

Wishing you success this year, we are,

Yours truly,

CADY & OLMSTEAD JEWELRY CO.,
Per E. A. Hosier, Secretary

Write us at once for samples and particulars FREE

Our representatives visit nearly every State in the Union. If you are interested, and will notify us, our representative will take pleasure in calling on you and explaining our method.

THE ARNSTINE BROS. COMPANY

Originators of Our Exclusive Catalog Method for the Retail Jeweler

CLEVELAND, OHIO

WHEN WRITING US, PLEASE MENTION THE "JEWELERS' CIRCULAR-WEEKLY"

Cincinnati.

George M. Braham, of A. & J. Plaut, left last week on his regular eastern business trip.

Lee Loeb and Mayo Loeb, of Herman & Loeb, have started in their respective trips east and south.

W. H. Broer, Toledo, O., called here last week on his return from the south, where he had spent several weeks.

James Holland, of the John Holland Gold and Silver Co., served on the jury the past week the McAlpin burglary case.

Herman E. Promnitz, Vine St., and Max Greenwald, Arcade, are both very much delighted over the arrival in their respective homes of a baby girl.

Joseph Kramer, of Lindner & Co., was kept away from business several days of the past week, owing to the death of his sister, Mrs. Huninghake.

Sol. Fox, of Fox Bros. & Co., received a communication from their agent in Amsterdam last week that while American business there is at a standstill, there were a number of purchasers from Russia, Austria, Germany and Paris.

The Wyoming Masonic Lodge, of which Lewis H. Becht, of A. & J. Plaut, is worshipful master, has received special dispensation from the grand master of the state to appear in public at the laying of the corner stone of the new Wyoming town hall, April 4, 1908.

Mrs. Wegelin, who was arrested some time ago under the name of Mary Brown, charged by Joseph Mehmert and N. Eich, a watchmaker, with the theft of two diamond rings, and who was later tried and acquitted, has now brought suit against Mr. Mehmert for \$5,000 damages.

The Gem Jewelry Co., Arcade, has discontinued the retail jewelry business, and its members will devote their time entirely to their wholesale department. The company is also enlarging its spongeable linen collar business, which it has been running in connection with the jewelry business.

R. G. Maas, of A. A. Spiegel & Co., tells of a narrow escape he had from the explosion at the Cleburne Hotel, in Helena, Ark., last week. Mr. Maas, in company with Sig. Frank, of the Crescent Jewelry Co., was seated in the dining room at the evening meal when almost directly underneath their part of the room a hot water heater in the basement exploded, tearing away a portion of the floor in the dining room. This caused a general panic among the guests, but fortunately no one was seriously injured. Mr. Maas and his friend escaped with only a shower bath of hot water.

Out-of-town jewelers here the past week purchasing stock included: Mr. Rose, of the Jobe-Rose Jewelry Co., Birmingham, Ala.; Owen Sherwood, Falmouth, Ky.;

Albert M. Stamm, Williamsburg, O.; C. Meyer, Harrison, O.; A. G. Weisman, Harrodsburg, Ky.; Albert Zoeller, Portsmouth, O.; Charles Sederberg, Milford, O.; Philip Horr, Aurora, Ind.;

Risinger, Lawrenceburg, Ind.; J. D. Messelbrock, Liberty, Ind.; J. N. Calvert, Russellville, O.; N. H. Marcoffsky, Huntington, W. Va.; Mr. Sirling, Columbus, Mo.; O.: L. Rosenbaum, Hopkinsville,

Ky.; A. J. Shaw, New Richmond, O.; A. W. Zeff, Princeton, Ky.; M. G. Straus, Castleton, N. Dak.

Cleveland.

J. H. Heiman has been in Canada during the past week.

J. Wynde Armbruster, of the Illinois Watch Co., visited this city March 14.

F. H. Kramer, Biskind Bros., and the Franklin Jewelry Co. are holding auctions to reduce stock.

Col. J. L. Shepherd, of the New York office of the Keystone Watch Case Co., was in Cleveland last week.

W. H. Saxton, of the Webb C. Ball Watch Co., is making his usual March trip through Pennsylvania and New York.

W. F. Miller and A. E. Ellbogen, representing the Bowler & Burdick Co., started out on their regular trips during the past week.

W. H. Wagner, of the Sigler Bros. Co., recently gave a talk at Lincoln, Nebr., before the Nebraska Retail Jewelers' Association.

Retail dealers purchasing in this city during the past week included L. J. Goddard, Ravenna, O.; D. A. Oberholtzer, for W. C. Fisher, Lorain, O.; W. G. Gilger, Norwalk, O.; A. B. Nolf, Wadsworth, O.; Geo. F. High, Medina, O.; G. D. Davidson, Jersey City, N. J.; E. H. Schaefer, Beaver Falls, Pa.

A representative of the Jewelers Security Alliance was recently incorrectly informed of the death of Ben Sands. Walking into his store he inquired of Sands particulars with reference to the estate, whether the business would be continued, etc., etc. Sands informed the representative that he was not dead, although business was temporarily.

For the fourth time this Winter, Chas. Ettinger is the victim of window smashers. Burglars carried off the display at his store, 430 Euclid Ave., early Monday, March 16, securing several hundred dollars' worth of watches and jewelry. Altogether in the various robberies Mr. Ettinger has lost about \$2,000 worth of goods, none of which the local police have recovered. Mr. Ettinger's loss has been fully covered by insurance.

Denver.

Wm. P. Jones, Fort Lupton, has been in the city for a few days buying stock.

Oly Olson has been very sick since coming home from an auction sale at Twin Falls, Idaho.

Clifford Huey, with Lyman Bros., is again back at his work after an illness of several weeks.

E. C. Loper, Loveland, has been visiting the trade in this city for the past week, replenishing stock.

E. T. Jones, formerly a watchmaker for the Bohm-Allen Jewelry Co., has resigned his position to go to Kansas City, where he has accepted a similar position.

F. S. Bentz, with W. W. Hamilton & Co., returned, last week, from his trip through the northwest. He reported a successful business, considering the time of the year.

S. Richards, formerly of Boulder, and

for the last few months a jeweler of this city, left, last week, on a short vacation. He will visit New York and some of the eastern States.

Wm. Pearson, Louisville, Colo., was in this city for a few days, last week.

L. H. Hall was in this city for a few days, last week, buying stock. He reports a fair trade for Trinidad and the vicinity.

Kansas City.

L. U. Jeanneret has removed his jewelry store from 808 Walnut St. to 15 E. 5th St.

S. Randazzo has returned from New Orleans and contemplates opening a jewelry establishment in this city.

The Green Jewelry Co. has added Samuel Lee, recently with the C. B. Norton Jewelry Co., to its engraving department.

F. W. Washam has recently enlarged his jewelry store at 3007 Gumotte Ave., this city. He now has double his former amount of store space.

J. H. Wagner, Ash Grove, Mo., and Earl C. Young, Coffeyville, Kans., have been enrolled as students at the Kansas City Polytechnic Institute.

A. E. Pittinger, of the Kansas City Horological and Optical School, whose health has been impaired since the holidays, will spend a week or two at Excelsior Springs, Mo.

Mrs. K. G. Nevin, mother of Nevin Bros., celebrated her 75th birthday, Friday, March 13. Mrs. Nevin, who suffered from a serious illness early in the Winter, recently caught cold and has been quite ill during the past week.

Frank M. Bogard, who graduated from the Kansas City Horological and Optical School some years ago, but who has recently been employed in Broken Bow, Nebr., has taken a position with C. M. Hoen, Clinton, Mo.

E. I. Jones, recently with Bohm-Allen Jewelry Co., Denver, Colo., has accepted the position as instructor in the Kansas City Horological and Optical School. Mr. Jones is well known to the jewelry trade in Denver, Omaha and this city, and is regarded as a first-class man for his new position.

The following out-of-town jewelers were in this city last week: S. J. Strickler, Salina, Kans.; Ora Stutzman, Garden City, Mo.; J. O. Van Voorhis, Osawatimie, Kans.; Percy Wilkins, Marceline, Mo.; D. E. De Lanty, Parkville, Mo.; A. Kroencke, Concordia, Mo.; A. A. Ditter, Mound Ridge, Kans.

C. P. Kionka, of the firm of Kionka & Kionka, has returned from a business trip to Texas. He found trade much better than he expected. Crops, he says, are in fine condition and everything points to a prosperous year. E. Kionka has gone to Texas to look after some lands owned by the firm. He will be absent a week or 10 days.

The Gurney & Ware Jewelry Co. has rented temporary offices in the Scarritt building. Mr. Dana, who represents Mr. Kirby, the purchaser of the Gurney & Ware stock at the receiver's sale, says the offices are kept up for the purpose of winding up the company's business. He expects to be through in about 10 days, after which he will return to New York.

Fine Hand-Made Diagonal and End-Cutting Pliers



No. 2886. Plain, \$1.25

No. 2887. N. P., \$1.45

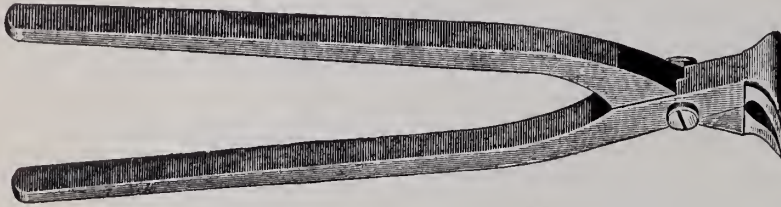

No. 2888. Plain, \$1.25

No. 2889. N. P., \$1.45

SWARTCHILD & COMPANY

Heyworth Building, Chicago

If you have not a copy of our double-sized 440-page Catalogue, write at once. Sent gratis upon application.

The Largest Exclusive Jewelers' Supply House in the World

TRADE



MARK

Geo. O. Street & Sons

35 Maiden Lane, New York

Established 1837

RINGS
SLEEVE-LINKS
SCARF-PINS
FOBS AND SEALS

ARTHUR REICHMAN

DEALER IN

AMERICAN BAROQUE PEARLS

65 Nassau St.

New York

Tel. 4457 }
4458 } Cort.

JOHN M. RICHARD 2 MAIDEN LANE Room 302, NEW YORK

American Pearls and Baroques

MATCHED PAIRS FOR EARRINGS The Largest and Finest Assortment in the Market, Mounted and Unmounted.

LOUIS FELDENHEIMER

Importer and Cutter of

PRECIOUS STONES AND PEARLS

41 MAIDEN LANE

NEW YORK

A NEW CREATION IN

Hat Pins

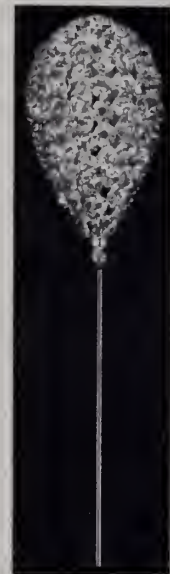

Made of the finest brilliant Rhinestones. Can be sold for less than the imported ones. They come in pear, ball and half ball, octagon and heart shapes, and can be retailed from

50c.

to

\$5.00

at a handsome profit.

Ask your jobber or write us for sample assortment.

ACME COMB AND NOVELTY CO.

Manufacturers

147 Spring St., New York

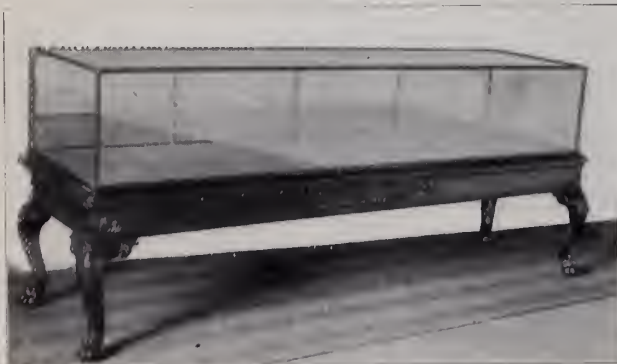

No. 11. Show Case and Table.

"FOR A QUARTER OF A CENTURY"

We have been manufacturers of

High-Grade Jewelry

Fixtures

Correspond with us before placing your orders

ALEXANDER H. REVELL & CO.

Rees, Dayton, Eastman and Hawthorne Streets, Chicago, Ill.

Indianapolis.

There are 60 retail jewelers in Indianapolis according to the 1908 city directory just issued.

George S. Kern was official timer at the M. C. A. indoor track meet held last Friday night, in Tomlinson Hall.

The Indianapolis Retail Jewelers' Association has decided to hold only one meeting each month. The meetings will be held the first Monday night of the month. Suspected of having stolen several hundred dollars' worth of gold from dental offices in the northern part of the State, a man giving his name as Judson, was arrested at South Bend, last week.

Relatives of Newton D. Parker who live in Kansas have come to his rescue and furnished bond for his release, pending trial, Shelbyville. Some time ago Parker is alleged to have purchased a \$12 watch from J. Sykes, Shelbyville, tendering a check for \$25 and receiving \$13 in change. Later the check was found to be worthless.

Ralph B. Clark, Anderson, president of the Indiana Retail Merchants' Association, notified President J. P. Mullally, of the Indianapolis Retail Jewelers' Association, that he will address the latter organization on the evening of April 6. The meeting will be held in the directors' room of the Commercial Club, and all jewelers will be invited.

Local newspapers last week devoted considerable space to interviews with J. C. Pease and Carl Walk, of Julius C. Walk & Co., on the diamond situation. Both Mr. Pease and Mr. Walk expressed the opinion that diamonds instead of decreasing in value would soon increase. The local diamond market is very unsettled because of many rumors of lower prices.

The Indianapolis *Star* gave a beautiful silver trophy to the club having the largest number of automobiles in the parade held Monday afternoon. Automobile manufacturers and dealers of the city are having their annual show this week. Nine smaller prizes were awarded to winners of the hill-climbing contests and obstacle races. All official timers for the events were retail jewelers.

An interesting exhibit of Arts and Crafts French artists was held at the Herron Art Institute in this city, last week, embracing about 30 objects. Among them was an ivory statuette by Adolph Caron, a candlestick, silver vase, a bronze gilt tripod, a cup in old Berlin ware, an old open plate, a cigarette case and a Sevres blue cup, all by Lelievre. There were also a number of beautiful pieces by Mlle. Osselin, a sister of the famous painter of that name. It was by far the most interesting exhibit of arts and crafts ever seen in the city.

Pacific Coast Notes.

Mr. Delovage, of A. & M. Delovage, Portland, Ore., is now visiting B. Granich, Stockton, Cal.

Wm. N. Jenkins, Oakland, Cal., will soon move from his present location on Broadway, to 12th St.

Horace H. Allen, of the Morgan & Allen Co., San Francisco, is now on a business trip to Los Angeles, Cal.

A. Duncan, manager of the Hanford Jewelry Co., Hanford, Cal., has made arrangements with Floyd Englebeck, a manufacturing jeweler, by which the latter will take space with him in the store.

San Francisco.

TRADE CONDITIONS.

The volume of business on the coast is gradually increasing. Wholesalers who are going out after the business are satisfied with results, and those who have a well assorted stock report good sales.

Jos. Hoeslech, Seattle, has just arrived here from China.

F. M. French, Albany, Ore., is in this city visiting old friends.

A. Fink, Los Angeles, visited the San Francisco trade last week.

Julius Wise, with J. S. Lehrberger & Co., returned from the east last Saturday.

Geo. McCarthy, formerly with Armer & Weinshenck, is now with R. & L. Myers.

R. & L. Myers are putting a 16-foot sign on the side wall of the building where the new store is located.

L. O. Levison, of the California Jewelry Co., has just arrived here, after an extended trip in Europe and the east.

A sneak thief got away with an \$80 diamond brooch from the store of Peter Johnson & Co., Van Ness Ave., last week.

Mosk & Co., formerly of Golden Gate and Van Ness Ave., has taken a small store at the corner of Market and Geary Sts.

A. L. Welisch, who for some time represented Geo. Greenzweig & Co. in the outside territory, has resigned from that position.

The Denver Jewelry Co., with stores here and in El Paso, Tex., is trying to make a settlement with creditors at 25 cents on the dollar.

Geo. A. Desenfant, who has been on Fillmore St. since the fire, expects to move within a few weeks to Market St., near 4th St.

The Sorensen Co., 715 Market St., has temporarily occupied an adjoining store in the same building, where a special sale is being held.

The Alexandra Jewelry Co. has taken an additional store on Fillmore St., and is holding a special auction sale there, as well as at the Van Ness Ave. store.

The down-town movement of the retail trade has taken a rather sudden start. Wm. Glindemann, located for the past year on Fillmore St., has secured a fine location in the Westbank building, at the corner of Market and Ellis Sts. He expects to take possession of the store about April 15, and will fit it up as a first-class establishment.

According to a decision recently handed down by Judge Dehaven in the Federal District Court, this city, M. J. Cornejo was obliged to forfeit \$12,000 worth of pearls which were smuggled by him across the Mexican border in 1906. The pearls will probably be sold at auction. An informal offer of \$12,000 has been made by a member of a large jewelry concern in this city.

The store of Sher & Son, 800 Front St., Allentown, Pa., was robbed of several hundred dollars worth of goods the other night, including the contents of a jewelry case. Two men were seen driving away from the store, but have not been apprehended.

Los Angeles.

TRADE CONDITIONS.

While there has been no very marked or rapid improvement in business conditions, there has been a gradual and encouraging advance along the line generally. This is more especially noticeable among the retailers. The manufacturers are doing a fairly good business and feel assured of at least moderate improvement in the future. While the jewelry trade is not likely to be directly helped very materially by the presence of the Evans fleet in this vicinity, the jewelers expect to profit by that event through the large amount of money which will inevitably be spent here by the great crowds which will visit this city.

H. J. Whitley arrived in New York, March 17, on his return from abroad.

R. H. Gilmore, of Gilmore & Lee, has returned from a successful business trip through the northern coast cities.

Mrs. J. C. Fleming, of the J. C. Fleming Co., who has been confined to her home by illness, has so far recovered as to be able to visit the store for a time every day.

Simeon A. Young, optometrist, formerly with the H. J. Whitley Co., but more recently in the east, has associated himself with Joseph Rittigstein, 427 S. Broadway.

Theodore Gribi, an expert and widely known watchmaker of Chicago, is spending some time in Southern California, visiting the different cities and towns up and down the coast.

Raoul J. Francoeur, an arts and crafts worker at 714 Bryson Block, recently made an exceptionally beautiful necklace, which is being exhibited in the store of the Pacific Gem Co., 335 S. Spring St.

Nathan Meyer, of S. Meyer & Co., returned a few days ago from a trip through Arizona. He reports business fairly brisk, with encouraging prospects of improvement. Isidore Behrstock, of the same company, is still on his northern trip.

Geo. M. Williams, proprietor of the Geneva Watch & Optical Co., participated in an automobile race against time from Fresno to this city, last week, beating all previous records, though the roads were in very bad condition in places.

S. Simmons, 315 S. Spring St., has had plans drawn for a new eight-story building to be erected on his property near 4th St. and Broadway, a short distance from the large store to be occupied by Montgomery Bros. The plans are drawn with special reference to the needs of wholesale jewelers, and he hopes to be able to rent the several upper stories to tenants of this class.

Pacific Northwest

Abendroth Bros., Portland, Ore., are about to move to a new store.

Jaeger Bros., Portland, Ore., will move to their new quarters in a few weeks.

L. W. Ross, Wasco, Ore., has purchased the Draper residence in that town, and is having it improved for his home.

J. G. Turner, of the firm of Turner & Barber, Caldwell, Idaho, was a business visitor in Middleton, Idaho, last week.

J. F. Sumner & Son, Middleboro, Mass., have rented quarters in Sagamore, in the same State, where they will open a branch store.

A. W. Holmes, formerly engaged in business at Alpena, S. Dak., has moved to Lawrence, Kans., where he has opened an attractively furnished store at 185 Bridge St.

Connecticut.

M. W. Hill has been appointed collector for the funds of the New Milford Fire Department.

The annual meeting of the International Silver Co. for the election of directors for the ensuing year will be held in Jersey City, N. J., to-morrow, March 26.

Peter Osborn, formerly in the employ of the Seth Thomas Clock Co., Thomaston, left, March 17, for his home in Ireland, where he will reside permanently.

Walter Camp and wife gave a dinner at the New Haven Hotel, New Haven, March 18, in honor of President Arthur T. Hadley and wife. Several prominent men were among the guests.

W. O. Davis has assigned to the Ansonia Clock Co., Ansonia, a patent which he was recently granted on an alarm clock. W. E. Porter has assigned to the same concern a recently patented watch.

Herbert Foster, general accountant and cost expert with R. Wallace & Sons Mfg. Co., Wallingford, has been appointed lecturer on the "Problems of Business Methods" in the Sheffield Scientific School.

Irving H. Chase, H. L. Wade, C. F. Brooker, C. P. Ross, J. H. Goss, P. D. Hamilton and G. A. Goss are among those who have taken stock in the issue of \$50,000 capital stock by the Waterbury Country Club.

Canley Hanson stole a valuable clock from the jewelry department in the general store of the Edward Malley Co., New Haven, March 18, and was soon after taken into custody. He was fined \$7 and costs and sent to jail for 30 days.

Col. Clayton H. Case, Hartford, was one of the officials for the work in conferring the Malta degree at the special conclave of the Washington Commandery, Hartford, March 17, and in preparation of the 81st annual conclave of the Connecticut Grand Commandery, in this city, March 18.

A carboy of vitriol belonging to R. Wallace & Sons Mfg. Co., Wallingford, caught fire at the owner's yards one afternoon last week. The car was side-tracked, and after an attempt to send in a fire alarm had failed word was sent to the Wallace hose house and the concern's fire fighters soon extinguished the blaze.

Edwin Hobson, at one time in the employ of Simpson, Hall, Miller & Co., Wallingford, died at his residence in E. Center St., at that place, March 14, of old age. The deceased was 87 years of age and was born in Sheffield, Eng. He is survived by six children. The funeral was held from Mr. Hobson's residence and burial was in In Memoriam Cemetery.

Joseph Bauer was recently arraigned in the city court in Bridgeport, and identified as the man who snatched a handful of diamonds from a tray in the store of Parker, Kolb & Co., Bridgeport, about a week ago. R. S. Kolb and a clerk named Robinson, who waited on Bauer, both identified the accused as the man who took the diamonds. Bauer was held for the Superior Criminal Court under bonds of \$100.

At the recent annual meeting of the stockholders of the H. C. Thompson Clock Co., Bristol, the usual board of directors was re-elected and the officers elected for the

coming year were: President, Mrs. H. C. Thompson; vice-president, O. F. Strunz; secretary and treasurer, J. A. Cairns; general manager, Ralph Urwin. The annual report showed the company to have transacted more business during the past year than ever before.

While Israel Goldstein, Jr., a jeweler at 112 Congress Ave., New Haven, was talking to a customer on the evening of March 17, a thief broke the glass in the side of his front show window and grabbed a tray of diamonds worth about \$2,000. The jeweler, accompanied by a number of citizens, immediately followed the thief, who was finally captured in a house in which he had taken refuge. All the jewels except one, worth \$165, were recovered. The prisoner gave his name as Warren W. Wilcox, and says that he came to New Haven a short time ago from Springfield, Mass. He is about 33 years of age. He was held under bonds of \$1,200.

Rochester.

The formal incorporation of the Bausch & Lomb Optical Co., to manufacture optical, engineering, astronomical, chemical and photographic instruments, devices, etc., was announced Monday. The capital is \$600,000 and the incorporators are John J. Bausch, Henry Lomb, Edward Bausch, Rochester, N. Y., and others.

An interesting suit has been commenced against A. R. Kime, a local optician, by Stevens & Co., the Providence manufacturers of optical goods. The action is for libel, for which \$5,000 damages are asked, and arose out of an advertisement of Kime's which read as follows: "I have purchased 25 gross of gold-filled eyeglass mountings manufactured by Stevens & Co., of Providence, R. I. Stevens & Co. withdrew from the Optical Combine on Jan. 1. They say that it cost them about 33½ per cent. to maintain trust prices. This saving of a third they have given to me because I am not in the optical combine in Rochester. And now I am going to give it to you." This is declared by Stevens & Co. to be false, scandalous, malicious, etc., as the concern denies that it was ever in any optical combine or ever gave Mr. Kime any special prices or advantages over any other dealers.

Buffalo, N. Y.

The Niagara Ring Mfg. Co., formerly at 16 E. Eagle St., is now comfortably settled in its new building at 534 Main St.

Mrs. Francis McIntosh, formerly advertising manager for the Norton Co., Worcester, Mass., is now acting in that capacity for the Buffalo Forge Co., Buffalo Steam Pump Co. and the Geo. L. Squier Mfg. Co.

Alfred O. Bald, 270 W. Ferry St., was notified early Wednesday morning last by a patrolman that some one had smashed the plate glass window of his store. Mr. Bald quickly made an inventory, but could not discover that much of value had been taken. It is believed by the jeweler that the thief was frightened away before he had finished his work. The broken glass was valued at about \$150.

The police of this city who have been making an investigation into the robbery

of the Jno. Reinhardt jewelry store, 1190 Lovejoy St., have come to the conclusion that the robber who got away with a tray of jewelry worth about \$5,000, March 15, must have been assisted by two other men. The man smashed the window in Mr. Reinhardt's store and got away with the tray before the jeweler could catch him, though the latter pursued him for some distance, and the robber dropped some of the 40 diamond rings which he had taken.

Omaha.

The manufacturing jewelers of this city report a larger business for March than they have enjoyed in several previous years.

F. E. Sandwall, South Omaha, is serving on the jury.

Geo. W. Ryan went to Percival, Ia., on business last week.

Sidney Mandelberg left for Kansas City, Mo., last week on business.

Emil H. Leffert, Council Bluffs, Ia. is visiting his brother at Portland, Ore.

Purde Firschenberger, with L. E. Griffith & Co., has returned from a visit to his old home in Seneca, Kans.

B. F. Smith, Valley, Nebr.; M. C. Sherman, Rising City, Nebr.; P. S. Holtzinger Pleasanton, Nebr.; A. M. Cross, Pierce, Nebr.; and Mr. McIvan, Red Oak, Ia., were in this city last week replenishing stock.

A large number of thefts have been reported lately. Jewelers have been asked to be on the lookout for a diamond sunburst brooch, star-shaped and the size of a 50-cent piece, which was stolen last week. It is valued at \$300, and a reward of \$50 has been offered for its return.

W. K. Burk, of the Merry Optical Co. Kansas City, Mo., was jostled by four men as he stepped aboard a Missouri Pacific train at Union Station, one night last week and a diamond stud valued at \$50 was taken from him. The same evening a gold watch and chain was taken from the pocket of J. J. Crabil, Nebraska City, while mingled in a crowd on Farnam St.

Minneapolis and St. Paul

The Blumencranz Jewelry Co. has begun making alterations and improvements at its store at 235 Nicollet Ave., Minneapolis and expects to move there from 231 Nicollet Ave. in a short time.

Cohen Bros., Minneapolis, have moved from 235 Nicollet Ave. to their new store at 412 Nicollet Ave., which they are rapidly getting in shape. They will have a most attractive establishment when everything is completed.

W. M. Stone, 16 S. 3d St., Minneapolis states in a recent communication to THE CIRCULAR-WEEKLY that the short change thief who, as reported in this journal, has been operating extensively throughout the country of late, also visited Minneapolis where he gave his name as Miller. He is described as being about five feet six inches tall, weighing about 140 pounds, and having short black hair, black eyes, dark skin, a smooth-shaven face. He is a Hebrew, although not of the decided type, and is somewhat reserved in his actions. He talks rapidly and persistently. When last seen he wore a black derby hat and a dark gray cravenette coat.

INDEX TO ADVERTISEMENTS.

Al Bros. & Co.	24	Heller, L. & Son	50	Prybill, P.	111
Ale Comb & Novelty Co.	78	Herpers Bros.	104	Racine, Jules, & Co.	99
Ans. T. W., Co.	9	Himalaya Mfg. Co.	52	Randall, C. Ray	15
Arm Mfg. Co.	Inside front cover	Hodenpyl & Walker	54	Ranlett & Lowell Co.	98
American Gem & Pearl Co.	60	Hoffman Novelty Co.	29	Reichhelm, E. P., & Co.	104
American Platinum Works	110	Holdfast Scarf Pin Guard Co.	38	Reichman, A.	78
American Watch Case Co.	98	Hold On Clutch Co.	31, 39	Renzlehausen, W. F., & Co.	110
Arch Crown Mfg. Co.	30	Hotel St. James	111	Revell, A. H., & Co.	78
Arizona Turquoise Mines Co.	34	Hraba, Louis W.	106	Richards, J. M.	78
Austein Bros. & Co.	46	Hyde & Co.	98	Richards, W. E., Co.	35
Austine Bros. Co.	76	Illinois Watch Co.	74	Richardson, Enos, & Co.	26
Austin & Stone	14	Ingersoll, Robt. H., & Bro.	101	Robbins, Chas. M., Co.	31
Austin, John, & Son	111	Irons, Joseph	31	Robert, E. E.	97
Bagg & Co.	56	Irving Cut Glass Co.	106	Roger Williams Silver Co.	35
Baker, Geo. M.	104	Jacot Music Box Co.	108	Rohrbeck, John E.	34
Ball, Webb C., Watch Co.	99	Janitschek Co.	104	Roseman, A.	50
Bachkopf, Henry	32	Jeanne, F. A.	56	Roy Watch Case Co.	38
Bassett Jewelry Co.	34	Juergensen, Jules	99	Rudolph & Snedeker	99
Bastian Bros. & Co.	16	Inzek, T. J., & Co.	98	Rumpp, C. F., & Sons	108
Bates & Bacon	17	Kahn, L. & M., & Co.	46	Saart, W. H., Co.	16
Beege, J. & H.	111	Keller Jewelry Mfg. Co.	28	Saunders, Mourer & Co.	58
Bellings, Chester, & Son	54	Kelly & Stellman	106	Schultz & Co., Inc.	28
Bishop, R. W.	111	Kent & Woodland	28	Sessions Clock Co.	99
Bickinton, R., & Co.	12	Ketcham & McDougall	40	Shepard Mfg. Co.	37
Birelli & Vitelli	60	Keystone Watch Case Co.	92	Smith, Alfred H., & Co.	50
Birwin, J. B., & Co.	22	Kleby, H. A.	66	Smith, Frank W., Co.	18
Bridley Polytechnic Institute	100	Kohlbusch, Herman, Sr.	104	Snow & Westcott Co.	30
Brown, D. F., Co.	18	Kohn, Alois, & Co.	27	Sohn & Hyman	62
Bryant, M. B., & Co.	22	Kremenz & Co.	25	Solidarity Watch Case Co.	21
Burter, Howe & Co.	27	Langendorf Watch Co.	98	Spencer, E. L., Co.	35
Buttham National Bank	70	Larter & Sons	44	Star Watch Case Co.	6
Chicago Art Metal Works	30	Lederer, S. & B., Co.	36	State Bank	68
Chopard Frères	30	Lees & Sanders	110	Steiner, Louis	106
Chittie, S., Co.	29	Lelong, L., & Bro.	111	Stern Bros. & Co.	56, inside back cover
Chiles & Court	33	Lewy & Coheu	33	Sterman, S., & Co.	14
Chisholm, M.	50	Lisner, D., & Co.	23	St. Louis Watchmaking School	98
Choss & Beguelin	56, 66	Lorsch, Albert, & Co.	46	Street, Geo. O., & Sons	78
Chossman Co.	50	Loth, Joseph, & Co.	36	Sussfeld, Lorsch & Co.	100
Chouch & Fitzgerald	106	Lowe, Edwin, & Co., Inc.	34	Swartchild & Co.	78
Chry, Clark & Co.	29	Maiden Lane Realty Co.	72	Theberath & Co.	27
Chycon, Louis J.	30	Maintien Bros. & Elliot	32	Title Guarantee & Trust Co.	68
Chyxon, Wm., Inc.	110	Manor, Charles E.	112	Trout, Charles L., & Co.	31
Chybran, Bagnall & Co.	37	Market & Fulton National Bank	68	Unique Art Glass & Metal Co.	108
Chybringer, C., & Sons	106	Mathey Bros., Mathez Co.	104	Untermeyer-Robbins Co.	62
Chybrer, O. M., Estate	33	Mercantile National Bank	69	Urich, S.	84
Chybois Watch Case Co.	94	Miller, Fuller & Whiting Co.	33	U. S. Scarf Pin Guard Co.	38
Chyber-Hampden Watch Mfg. Co.	10	Mitchell & Tillotson	39	U. S. Smelting & Refining Works	111
Chybn, T. J., Co.	34	Morstrom, W. G.	60	Vacheron & Constantin	97
Chyburand & Co.	26	Mount & Woodhull	56	Van Dam, Eduard	48
Chylichberg & Co.	62	Myers, J. A.	84	Van Dusen & Stokes Co.	21
Chyisenmann Bros.	54	Myers, S. F., Co.	30	Wachenheimer Bros.	35
Chygin National Watch Co.	90	Nassau Bank	68	Wachter Mfg. Co.	100
Chy P. H. Chain Catch	108	New England Watch Co.	96	Waite-Thresher Co.	40
Chyphys, Joseph, & Co.	3	New York Jewelry Purchasing Co.	32	Waldron & Carroll	32
Chyfeldenheimer, Louis	78	Nissen, Ludwig, & Co.	54	Waltham Watch Co.	88
Chyfoster, Theodore W., & Bro. Co.	42	Noel, Rudolph, & Co.	48	Washburn, C. Irving	111
Chyfreeman, B. S., Co.	36	Omega Watches	97	Wells, Chester H.	37
Chyfreund, Henry, & Bro.	22	Oneida Community, Ltd.	Outside back cover	Wendell & Co.	7
ChyGalaway, J. H., & F. H.	31	Oppenheimer Bros. & Veith	48	Wheeler, Hayden W., & Co.	48
ChyGarreand & Griser	50	Oskamp-Nolting & Co.	30	Whiting & Davis	15
ChyGillette Sales Co.	41	Osmers-Dougherty Co.	29	Whiting, F. M., & Co.	23
ChyGoldsmith, C. P., & Co.	39	Osmun-Parker Mfg. Co.	26	Whiting Mfg. Co.	13
ChyGoodfriend Bros.	58	Ostby & Barton Co.	17	Wightman & Hough Co.	34
ChyGorham Co.	64	Pairpoint Corporation	106	Wittnauer, A., Co.	98
ChyGreene, Wm. C., Co.	32	Papazien, A. D.	99	Wittstein, Chas. T.	30
ChyGriffon, August	104	Patek, Philippe & Co.	96	Wolcott Mfg. Co.	8
ChyGugenheim, M.	37	Penfold, Wm. C., Co.	100	Wolfsheim & Sachs	38
ChyGagstoz, T. B., Ltd.	110	Peninsular Engraving Co.	19, 20	Wollstein, L. & M.	111
ChyGammel, Riglander & Co.	11	Pitcairn, W. S.	108	Wood, Chas. F., & Co.	54
ChyGarris & Harrington	99	Pitzele, S.	38	Wood, J. R., & Sons.	4, 5
ChyLegges, A. J., & Co.	28	Potter & Buffinton Co.	36	Zarembowitz, A.	104
ChyLedges, Wm. S., & Co.	58	Prior, Charles M.	38	Zimmer, Henry, & Co.	112

Special Notices.

Payable invariably in advance.

Rates 75c. per insertion for notices not exceeding 25 words; additional words, 2c. each.

SITUATIONS WANTED, 1c. a word each insertion; minimum charge, 25c.

Heavy type, 5c. a word; minimum charge, \$1.25. Display cards, \$2.00 per inch.

In all cases, if answers are to be forwarded, 10c. extra to cover postage must be enclosed.

All answers to advertisements addressed care The Jewelers' Circular-Weekly, should be sent to the New York Office, unless the Chicago Office is specifically mentioned.

Situations Wanted.

ENGRAVER and saleslady, experienced; best of references. Address "L., 3514," care Jewelers' Circular-Weekly.

COMPETENT watchmaker and jeweler wants position at once; reference from present employer. H. J. Weiser, Waycross, Ga.

THOROUGH, practical, rapid and experienced watch repairer, disengaged April 1. J. A. Coon, 548 Warren St., Hudson, N. Y.

A JEWELER and setter wants to get a position, can do engraving. Xaver Langenwalter, third floor, 300 E. 83d St., New York.

POSITION WANTED by engraver; all kinds of lettering and monograms; references given. Urban Dean, Cameron Mills, N. Y.

EXPERIENCED silverware and jewelry salesman, road or retail, retail preferred. Address "R., 3594," care Jewelers' Circular-Weekly.

YOUNG MAN, jeweler, wishes position; can wait on trade; best of references. Address "L., 3814," care Jewelers' Circular-Weekly.

STENOGRAPHER, bright, ambitious beginner, desires position; moderate salary with advancement. Rose Woticky, 445 E. 87th St., New York.

MELTER, refiner, press and drop hand, seeks position in or out of town; can furnish the best of references. "L. B. W., 3747," care Jewelers' Circular-Weekly.

WANTED, position in south or west by jeweler or second watchmaker, good on new or repair work; best references. "A., 3875," care Jewelers' Circular-Weekly.

JEWELER and engraver, also watchmaker, wishes to change; south preferred; competent young man; references. Address "V., 3779," care Jewelers' Circular-Weekly.

WATCHMAKER and engraver, of long experience, no jewelry repairing, would like position with a reliable firm; good reference. Address F. Lane, Evansville, Ind.

YOUNG MAN, 9 years' experience in retail jewelry business, desires position in retail or wholesale house; willing to travel. "K., 3510," care Jewelers' Circular-Weekly.

HIGH GRADE man, 17 years' experience, 35 years old, is open for engagement, inside or outside salesman, buyer or manager. "C., 3752," care Jewelers' Circular-Weekly.

JEWELER, age 28, speaks French, German and English, six years with leading first class Parisian firm; best references. Address J. Lorentz, 210 E. 78th St., New York.

FIRST CLASS watchmaker, with tools, desires position at once; middle age man; competent to handle railroad work. Address "E. H. B.," 45 Charles St., Springfield, Mass.

A FIRST CLASS diamond and precious stone setter on all kinds of work, desires position; will go out of town. Address "First Class, 3745," care Jewelers' Circular-Weekly.

DESIGNER on class pins, medals, badges and fraternity pins, desires position with reliable house; can make attractive sketches. "C., 3676," care Jewelers' Circular-Weekly.

YOUNG MAN, thoroughly experienced in the jewelry business, wishes position as salesman; can furnish first class reference. F. Winter, 312 Stockton St., Brooklyn, N. Y.

YOUNG MAN, 21, having five years' experience with diamond furnishing house, desires to make a change; can furnish best of reference. "V., 3798," care Jewelers' Circular-Weekly.

YOUNG LADY, thoroughly experienced in the jewelry and silver business, and competent bookkeeper, desires position. Address "J. P. S., 3789," care Jewelers' Circular-Weekly.

YOUNG MAN desires position as engraver and assistant watchmaker; would take moderate salary for steady position. Address "A. C., 3784," care Jewelers' Circular-Weekly.

FIRST CLASS watchmaker, with full set of tools and good references, wishes position with reliable house in New York City or vicinity. "L. L., 3805," care Jewelers' Circular-Weekly.

EXPERIENCED watchmaker and engraver would like permanent position in first class store, desires a change; east preferred. Address "A. R., 3645," care Jewelers' Circular-Weekly.

POSITION WANTED, May 1, by young man, A1 jeweler and clock repairer, can help on watches and wait on trade; A1 references. "R., 3739," care Jewelers' Circular-Weekly.

A FIRST CLASS watchmaker, experienced in adjusting, manufacturing and repairing high grade watches, wants position. Address "L. F. P., 3763," care Jewelers' Circular-Weekly.

YOUNG MAN, 21, who has done some hard soldering, clock work and handled a few watches, wishes to get some more experience. Address M. J. Klevjord, Y. M. C. A., Dubuque, Ia.

YOUNG MAN, with good reference, lathe and tools, desires a position as watchmaker and engraver, with a chance to improve; south preferred. Robert E. Killings, Kershaw, S. C.

SALESMAN, high class diamond jewelry, desires to make a change; high class gold jewelry preferred; traveled east and middle west. Address "E., 3813," care Jewelers' Circular-Weekly.

ENGRAVER; high grade letter and monogram engraver open for position on or about May 1; young man, experienced; reference. Address Box 3744, care Jewelers' Circular-Weekly.

GILDER wants position; specialty, ormolu soft metal clocks and jewelry, 18 karat rose, green, French gray; long experience; good reference. "G., 3762," care Jewelers' Circular-Weekly.

ENGRAVER and salesman, who can repair clocks, wishes permanent position; eight years' experience; middle west preferred. Address "Engraver, 3768," care Jewelers' Circular-Weekly.

WANTED, a situation as watchmaker; 20 years' experience with best of reference; nothing but a first class position will be considered. Address Chas. E. Palmer, 29 South St., Waltham, Mass.

ENGRAVER, young man, A1 letter and monogram engraver, can act as salesman; experienced loan clerk; samples and best references. Address "D., 3788," care Jewelers' Circular-Weekly.

MANUFACTURING JEWELER, first class, wants position; 20 years' experience, six as foreman; can do everything from order to delivery; best references. Haag, 101 Dewey St., Newark, N. J.

WATCHMAKER and clock repairer, single man, 15 years' experience, no engraver; moderate salary; Ohio or adjoining States preferred. Address "Watchmaker," 818 N. Main St., Sidney, O.

MELTER, experienced, gold or silver, practical at preparing stock, solutions, alloys, solders, etc., handy with drop hammer or presses, also coloring. Address "J., 3680," care Jewelers' Circular-Weekly.

WATCHMAKER, for 28 years, desires position with a house who can furnish him 2,000 watches a year to repair; salary, \$25 a week. "Trade Watchmaker, 3792," care Jewelers' Circular-Weekly.

YOUNG MAN wants situation as second watchmaker, has a fair knowledge of the jewelry business, can give good references and is willing to work. "L., 3754," care Jewelers' Circular-Weekly.

SITUATION WANTED by first class watchmaker, salesman and optician; capable of managing; 21 years' experience, 36 years old, single; A1 reference. Address "R. J., 3722," care Jewelers' Circular-Weekly.

SITUATION WANTED by young man, can do all ordinary watch and clock repairing; wish to finish trade; wages no object; references; Wisconsin preferred. "B., 3737," care Jewelers' Circular-Weekly.

POSITION as salesman or manager with retail jeweler; 15 years' experience, good reference, married, 29, good address; just the man you want. J. P. Turner, 1729 Edmondson Ave. Baltimore, Md.

ENGRAVER, young man, desires position with first class engraver, or an opportunity to learn watch work; good script letterer; samples on request; A1 reference. "D., 3602," care Jewelers' Circular-Weekly.

YOUNG LADY desires position with first class house; thorough knowledge of jewelry business capable of taking charge and answering correspondence. "Trustworthy, 3769," care Jewelers' Circular-Weekly.

MANUFACTURER'S LINE wanted on commission for jobbers or department store trade in New York City; established trade, can show good improvements. Address Erle R. Sheppard, Maiden Lane, New York.

WATCHMAKER and engraver, capable of handling high grade work, desires steady position where clean work and honest effort is appreciated; wages, \$20 per week. "H., 3804," care Jewelers' Circular-Weekly.

WATCHMAKER, experienced on railroad watch and competent to take full charge of store repair department; good habits; 20 years' experience, good references. Address "Steady, 3802," care Jewelers' Circular-Weekly.

POSITION WANTED by young man, 35, as superintendent and foreman in silver shop; 5 years' experience, five years superintendent as foreman; A1 references. Address "Z., 378," care Jewelers' Circular-Weekly.

BOOKKEEPER, charge of stock, filling orders, selling; young woman, eight years in wholesale jewelry business, having entire charge; excellent reference; would leave town. Address "3786," care Jewelers' Circular-Weekly.

SITUATION by jobbing jeweler, can take charge of shop, all around man, can act as second watchmaker, 25 years' experience, best of reference, married, or would rent space in shop. Address "M., 3736," care Jewelers' Circular-Weekly.

A FIRST CLASS watchmaker, 25 years' experience on high grade American and Swiss watches, wishes a steady position; can start once in vicinity of New York City. Address "K., 3541," care Jewelers' Circular-Weekly.

A SALESMAN, with good following in the mid west, would like to engage with a manufacturer of high grade goods; I am a hustler and can go to good houses; good references furnished. Address "N., 3771," care Jewelers' Circular-Weekly.

TRAVELING SALESMAN desires change; best reference, with good trade in Pennsylvania, New York, Ohio, Michigan, Illinois, Missouri and Massachusetts; commission or salary. Address "G., 3710," care Jewelers' Circular-Weekly.

A FIRST CLASS watchmaker, with many years' experience in high grade adjusting and complicated watch work, wishes to make a change in his position; Pacific or western State preferred. "Watchmaker, 3750," care Jewelers' Circular-Weekly.

STRICTLY first class watchmaker, aged 30 years; 16 years' experience on all kinds of American Swiss and complicated watches, wishes to make a change about April 15; will go anywhere. Address "Reliable, 3793," care Jewelers' Circular-Weekly.

A YOUNG MAN wishes a position in New York as an optician and jeweler, 23 years old, six years' experience in Boston; own to salary, \$18 weekly; can come well recommended. Address George H. Bellows, 201 W. 141st St., New York.

YOUNG MAN, eight years' experience in retail jewelry business, wishes position as salesman; understands watches and all kinds of repairs; good recommendation; prefer New York City vicinity. Address "S., 3790," care Jewelers' Circular-Weekly.

YOUNG MAN desires position with comb manufacturers; thoroughly understands the design and working of French fancy combs, engraving, gilding and stone setting; English and American references. Address H. Iskin, 212 Christian St., Philadelphia, Pa.

GRADUATE refractionist and good jeweler, thoroughly experienced, desires position; can wait trade, give estimates on all jewelry and repairs, etc.; left last position of my own accord. References. "Refractionist, 3724," care Jewelers' Circular-Weekly.

SITUATIONS WANTED.—Continued

WATCHMAKER, 20 years' experience on high grade watch repairing, accustomed to waiting on trade and taking in and delivering work, desires good position with high class jewelers; not an engraver. "R. N. Y.," 11 S. Union St., Rochester, N. Y.

WATCHMAKER, first class, open for engagement; 30 years' experience; thoroughly competent on high class work, all kinds of American and Swiss watches; best New York references; not a time killer. Address "R., 3796," care Jewelers' Circular-Weekly.

YOUNG LADY, thoroughly familiar with jewelry business, A1 saleswoman, capable, wishes position of trust and responsibility, where merit will be appreciated, with wholesale or retail concern; best references. Address Miss Hanna Horwitz, 218 W. 138th St., New York.

WANTED, position by jewelry and clock repairer and optician, who does ring sizing, stone setting, some engraving, most anything in jewelry or clock repairing, understands edging lenses, familiar with little gem work. Address "L., 3765," care Jewelers' Circular-Weekly.

PRACTICAL watchmaker and French clock repairer, 27 years of age, nine years' experience, wishes steady position with first class house only; capable of taking full charge of repair department; A1 reference furnished. Address "Practical, 3741," care Jewelers' Circular-Weekly.

A1 WATCHMAKER, engraver and optician wants position with a first class house; short hours; do no clock or jewelry repairing; has tools and trial case, years' experience; want to take full charge of watch repair bench; good references. Address B. W. Lockner, P. O. Box 212, Hannibal, Mo.

SALESMAN, of intelligence, good habits and well recommended is open for engagement; sold general line in Ohio and Pennsylvania; well acquainted in large towns and cities; east or west with jobber or retailer; manufacturer's line preferred. Address "Opportunity, 3719," care Jewelers' Circular-Weekly.

ARTIST, first class badge, jewelry, medal, charm and monogram designer; best references given; salary \$15 per week. Box 3797, care Jewelers' Circular-Weekly.

YOUNG MAN, 24, single, desires permanent position; first class watchmaker, plain engraver and graduate optician; can act as salesman when necessary; own bench and tools, including lathe, etc.; moderate salary; six years' experience; Georgia or Tennessee preferred. Address "J., 3516," care Jewelers' Circular-Weekly.

OPTICIAN, first class refractionist, edge grinder and salesman, competent to take charge of department, who is also all around man in jewelry store, would like position after April 15, or would like good business proposition of medium size; busy New England city preferred. Address "Q., 3785," care Jewelers' Circular-Weekly.

FIRST CLASS watchmaker, fine letter and monogram engraver and graduate optician; 23 years' experience, five years on railroad watches; several years in present position; do not repair clocks or jewelry; would not go east of Indiana; town, 8,000 to 25,000; first class references. Address "S. J., 3623," care Jewelers' Circular-Weekly.

WATCHMAKER, first class, 20 years' experience, best reference, thoroughly competent on high grade Swiss, complicated and American railway watches, and rating of marine chronometers, desires permanent position with responsible house; state salary and particulars; prefer Texas, Louisiana and Colorado. Address J. Dias, 1804 Broadway, Houston, Tex.

Help Wanted.

WANTED, watchmaker and engraver or assistant watchmaker and engraver; permanent position; reference. S. Wolfram, Darlington, S. C.

WANTED, for Milwaukee, young German clockmaker; good appearance; wages, \$15. Apply Henry Freund & Bro., 71 Nassau St., New York.

WANTED, watchmaker, must be fine workman; address with past three years' complete references. Greenleaf & Crosby Co., Jacksonville, Fla.

WANTED, salesman calling on jewelry trade to handle side line of first class jewelry boxes; liberal commission. Horton Box Co., Buffalo, N. Y.

WATCHMAKER; assistant watchmaker for large store in northern New York; salary between \$14 and \$15. Address "P., 3673," care Jewelers' Circular-Weekly.

WANTED, first class watchmaker, capable of taking charge of repair department; salary, \$18 per week; references with first letter. W. H. Replogle, Shenandoah, Ia.

FIRST CLASS watchmaker and engraver to take charge of watch department; steady position; send references, state age, experience and salary wanted. S. Spitz, Santa Fe, N. M.

WANTED, three or four first class diamond polishers. Address, "D., 3690," care Jewelers' Circular-Weekly.

WANTED, first class jeweler to take charge of shop with retail store in Illinois; give references; permanent. Address "K., 3781," care Jewelers' Circular-Weekly, 501 Heyworth Bldg., Chicago, Ill.

WANTED, an experienced man who can do watch work and nice engraving and is a good salesman; situation in New York State; good salary. Address "Jeweler, 3764," care Jewelers' Circular-Weekly.

WANTED, a capable salesman in a jewelry store, must be a good window dresser and optician and have the best references as to honesty and ability. Address "E., 3743," care Jewelers' Circular-Weekly.

WANTED, a first class watchmaker, jeweler, plain engraver, also optician, one who can wait on trade; must have good references; steady position; state salary wanted. D. M. Rinaldo, Hot Springs, Ark.

FOREMAN; wanted, experienced foreman for active jewelry repair shop in New York City; apply by letter stating reference and salary wanted. Address "A. B., 3778," care Jewelers' Circular-Weekly.

SALESMAN, young man with experience wanted to handle established line of cheap goods with headquarters at Chicago; when answering give age, experience and salary expected. Address Box 172, Attleboro, Mass.

SALESMAN, acquainted with the retail jewelry trade east of Buffalo and in south, to sell boxes and display goods for manufacturer; state references and experience. Address "K., 3761," care Jewelers' Circular-Weekly.

WANTED, first class watchmaker, optician and engraver; permanent position to the right man in one of the growing cities of the southwest; population about 20,000. Address "A1, 3524," care Jewelers' Circular-Weekly.

SALESMAN to carry high grade line of popular priced fountain pens and ink pencils as principal or side line; liberal commission; compact samples; State territory and experience. Nathaniel Field, cor. Centre and Worth Sts., New York.

WANTED, at once, first class manufacturing jeweler and engraver for establishment with power plant; permanent employment; salary, \$25 per week, with increase; with reference. A. Levytansky, 108 W. Commerce St., San Antonio, Tex.

WANTED, A1 watchmaker; must be thoroughly competent on high grade Swiss and American watches, and a thorough mechanic, no one else need apply; sample of staff with first application. Julius C. Walk & Son, Inc., 10 E. Washington St., Indianapolis, Ind.

STERLING NOVELTIES and small sterling hollow ware; salesman with practical ideas as to salable goods wanted for large western trade; previous experience in this particular line absolutely necessary. Address "Manufacturer, 3728," care Jewelers' Circular-Weekly.

WANTED, by first class house in large Texas city, first class jeweler and engraver on new work and repairs; permanent position, good salary; send samples of engraving and copy of references in first letter. Address "L., 3694," care Jewelers' Circular-Weekly.

WATCHMAKER and jewelry repairer wanted; preferably one understanding French, German and English; congenial position in New York City. Address, "N. F. R., 3709," care Jewelers' Circular-Weekly.

A SALESMAN wanted with good trade to carry line of diamonds and jewelry for an established wholesale and manufacturing concern; must have a very small capital, so as to purchase an interest in the business; house will furnish good trade to call on; only a hustler with good reference need apply. Address, "Wholesale Jeweler, 3776," care Jewelers' Circular-Weekly.

Business Opportunities.

WANTED, a good paying retail jewelry business in New York City; willing to invest from \$5,000 to \$10,000. Anton J. Anderson, 170 Broadway, New York.

J. M. ROSSI, 20 Maiden Lane, New York, desiring to retire from active business, will sell his entire stock of high grade jewelry amounting to about \$2,000.

A RING FACTORY, doing fine work, and well equipped; a close price will be considered for cash offer; write if interested. Address "N., 3290," care Jewelers' Circular-Weekly.

STOCK OF GOODS, fixtures, tools, etc., established trade, old stand, large southern city; cash sale, \$6,000; reason for selling, want to get out of jewelry business. Chas. J. Schmitt, 623 Elm St., Cincinnati, O.

SPLENDID OPPORTUNITY for young man in town of 3,500 near Albany; business established, fixtures new, no stock; no opposition; reason for selling, other interest. "T., 3806," care Jewelers' Circular-Weekly.

BEST TOWN in Maryland where the money panic has not been felt, this year's business better than last; stock, \$2,500 to \$3,500; bench work will average \$125 to \$150 per month. "M., 3734," care Jewelers' Circular-Weekly.

FOR SALE; an opportunity to get an old established jewelry store, on one of the best streets in Washington, D. C., salable and clean stock, with a good repairing trade. For further information address "Opportunity, 3668," care Jewelers' Circular-Weekly.

FOR SALE, new, light jewelry factory; specialty, rings, dies, etc., completely equipped; 1,200 square feet; fine location; great chance to step right in; close price to jeweler if bought outright. Address "For Business, 3777," care Jewelers' Circular-Weekly.

FOR SALE, cheap, an established retail and trade watch and jewelry repair business in center of Atlanta, Ga.; all the work two men can do, can be increased; fine opportunity for man to open a material business; sickness reason for selling. F. C. Rockwell, Atlanta, Ga.

FOR SALE, on account of sickness, an enameling shop for jewelry, established for 25 years; would also accept a competent man for partner instead; location, Newark, N. J. Address "E., 3757," care Jewelers' Circular-Weekly.

FOR SALE; here is your chance of a lifetime, to walk right in a well established jewelry and optical business, in a live town; population 10,000; county seat; city has modern improvements; only one other small jewelry store; can draw from a large scope of country; stock and fixtures inventory \$7,000; can reduce stock to suit customer; will sell at a big reduction, as I wish to retire from business; watch inspector for the Norfolk & Southern Railway Co. C. H. Wallace, Washington, N. C.

Side Lines Wanted.

EXCLUSIVE Greater New York agency wanted by reliable firm; have five men covering territory; must be up-to-date proposition and A1 line. "E. 3746," care Jewelers' Circular-Weekly.

WANTED to represent A1 eastern manufacturer on commission in Chicago and vicinity; line of gold jewelry preferred; 14 years' experience; best references furnished upon application. Address "H., 3791," care Jewelers' Circular-Weekly, 501 Heyworth Bldg., Chicago, Ill.

Practical Course in Adjusting

By THEO. GRIBI

Comprising

A review of the laws governing the motion of the balance and balance spring in watches and chronometers, and application of the principles deduced therefrom in the correction of variations of rate arising from want of isochronism, change of position and variation of temperature.

Elucidated and Demonstrated

By original experimental researches in the actual problem, never before published, showing the causes that are operative in the variation of rate, and leading to correct remedies. To which have been added chapters on

How to make a Balance Arbor with Modern Appliances; How to Clean a Watch Properly; and, the Lever Escapement—Some Current Defects in it and How to Remedy Them.

Published Price, \$2.50.
**SPECIAL REDUCED
PRICE, \$1.50,**
Post Prepaid.

250 pages, including 18 diagram plates; Fine Paper; Large Type; Clear Illustrations; Systematically arranged; Solid Binding. :: :: ::

**THE JEWELERS'
CIRCULAR PUB. CO.**

Publishers

11 John St., cor. Broadway
NEW YORK

Special Notices.

(Continued from page 83.)

BUSINESS OPPORTUNITIES Continued.

HIGHEST cash prices paid for watches, diamonds and jewelry; quick and liberal returns; all business confidential; bank references. E. Noel, 552 E. 46th Place, Chicago, Ill.

DO YOU NEED MONEY? If so, send your diamonds and watches to me and get quick and liberal returns; highest cash prices paid for entire jewelry stocks; will send our representative if necessary; business confidential; National Bank references. H. Schwartz, 807 Chicago Savings Bank Building, Chicago, Ill.

DO YOU WISH TO RETIRE? Why not turn your entire store or surplus stock into cash? We pay the highest prices, also advance liberal cash amounts on stocks; communicate with us before consulting others; we act quick and strictly confidential. Brooklyn Purchasing Syndicate, 608 Broadway, Brooklyn, N. Y., Telephone, 2328 Williamsburg.

S. F. MYERS BLDG.

47-49 Maiden Lane, N. Y.

For Rent

A few choice, light and
very desirable offices

Moderate Rentals

Details of

J. A. MYERS

On Premises

WANTED WATCHMAKERS everywhere to know about

URICH Perfect Fitting

CASE SCREW WASHER

Will hold movements securely in their case, even when shoulder is worn away. Fits perfectly under head of screw, and is almost invisible. Prices:

Single Dozen, - - - - - 15c
4 Doz. Package, assorted, - - - 50c
Gross, - - - - - \$1.50 Pat. app. for

For sale at all Jobbing and Material Houses.

S. URICH, P. O. Box 1942, New York City

BUY WHAT YOU WANT

Stock and Fixtures or Fixtures alone, or Fixtures and part of Stock; Fixtures, \$790; elegant Stock, \$1,900. Missouri county seat; population, 2,500. Competition with small stock. Have done \$2,300 since July 20, 1907. Cash or part cash and bankable paper, 1 year. Wife's health, reason. Address

"T., 3740," care Jewelers' Circular-Weekly

FOR SALE; on account of other business interests, I am compelled to sell my prosperous jewelry store in northern Indiana; gross business, \$4,000; invoice, \$2,000; population, 1,500; finest farming section in the state; will give good discount for cash or will sell to responsible party one-quarter cash and balance on easy payments; write for particulars. Address, "D., 3758," care Jewelers' Circular-Weekly.

For Sale.

FOR SALE, jeweler's safe, inside dimensions, 24 x 27 x 30. Ford & Carpenter, 2 Maiden Lane, New York.

FOR SALE or trade, one five-light F. & P. new model gas machine in first class condition, will give as good light as electricity at half the cost. Address Wm. Moore, Newcomerstown, O.

FOR SALE, a one-fifth horse power, direct current, polishing, drilling, grinding and lathe motor, in perfect condition; manufactured by the W. Green Electric Co.; price, \$20. R. C. Green's Son, 8 S. Centre St., Pottsville, Pa.

FOR SALE, one 5 foot 6 inch mahogany roll top desk and chair; also one-fourth horse power electric, direct current, buffing and polishing motor lathe, complete with starting box and bench, in perfect running order; would be useful to any jeweler who is without one; bargain. Towle Mfg. Co., 41 Union Sq., New York.

To Let.

PART of desirable office occupied by silversmiths, Room 308, 320 Fifth Ave., cor. 32d St., New York.

FOR RENT, one-half of, or desk room in light office, Room 606, Jewelers' Bldg., 9 Maiden Lane, New York.

TO LET, small, light office; \$10 a month, also half of large office. Room 103, 1 Maiden Lane, New York.

TO LET, part of office, suitable for jewelry samples; very low rental. Please call or address Room 412, 38 W. 33d St., New York.

TO LET, a desirable office, 170 Broadway, with or without partitions; liberal reduction in rent. Particulars, Room 1003, 527 Fifth Ave., New York.

SHARE in office to let, located in New Silversmiths Building, New York; 10 karat gold, silver or ring line preferred. "O., 3775," care Jewelers' Circular-Weekly.

TO LET, third floor of building in Newark, N. J., opposite Market St. station, with steam heat, power and elevator service; size of floor, 115 ft by 39 ft; well lighted and specially adapted for manufacturing jewelers. Address Cyrus Turner & Sons, 365 Market St., Newark, N. J.

Wanted to Purchase.

WANTED, jeweler's power rolling mill, one with good size rolls; must be in first class condition and reasonable in price. Address with particulars to Edward Todd & Co., 1 W. 34th St., New York.

Miscellaneous.

SEND for sample bargains; 50 doz. brooches, \$2 doz.; 50 doz. link buttons, \$1.25 doz.; 40 doz. scarf pins, 75 cents doz.; 40 doz. beauty pins, 50 cents doz.; 40 gross collar buttons, \$1 a gross; less than half wholesale price; can use watches, diamonds or cash. E. L. Wood, Cleveland, O.

THE OPTICAL REVIEW

FOR APRIL

☐ A High Class Magazine for Opticians and Optometrists.

☐ A Worthy Representative of an Important Industry.

☐ Publishes the Best Optical Literature Procurable and All the News.

THE OPTICAL REVIEW is the greatest aid to the advancement and progress of the optical department, the optician and optometrist.

No jeweler with an optical department can afford to be without it.

CONTENTS FOR APRIL

"Nervous System and the Sense of Sight." By F. Lee Fuller, Los Angeles, Cal.

"Suggestions to Optometrists." By I. M. Radabaugh, Hastings, Minn.

"Theoretical Skiametry." By Ralph H. Woods, South Bend, Ind.

"Simple Methods in Subjective Optometry." By W. P. Hedrick, Raleigh, N. C.

"Phacology: Its Application in Optometry—III." By R. H. Knowles, M. D., New York.

"Prisms in Ocular Practice—X." By John C. Eberhardt, Dayton, O.

"Ophthalmic Measurements." By E. Le Roy Ryer, New York.

Digest of Current Optometrical Literature—Examination Room Work—Optometrist's Catechism—Questions and Answers—Making the Sale—New Articles for Store and Office—Editorials—News of the Month—Developments in the Movement for Optometry Laws—Conventions of State Societies—Other Meetings—Patents.

☐ We exclusively extend to subscribers of THE JEWELERS' CIRCULAR-WEEKLY the privilege of subscribing to THE OPTICAL REVIEW at one-half price—50 cents per year. If you have not already mailed your subscription, simply sign and return the attached form, sending no money in advance.

☐ Carefully read the blank below. Send at once and get the April issue.

ISSUED MONTHLY.

SUBSCRIPTION, \$1.00 PER YEAR.



Published by
THE JEWELERS' CIRCULAR PUBLISHING CO.,
11 John Street, cor. Broadway, New York

Commence

N. B.—This subscription will be billed concurrently with your Jewelers' Circular subscription. It can be stopped at any time.

Please enclose your business card or printed address

..... 190

Send "THE OPTICAL REVIEW" to my address until otherwise ordered, for which I agree to pay **50 cents a year** as a special introductory combination price with my subscription to the JEWELERS' CIRCULAR-WEEKLY.

Name

Street

City

State

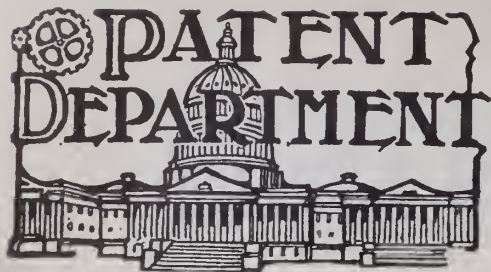

[IN WHICH IS CONTAINED A LIST OF THE LATEST PATENTS GRANTED BY THE UNITED STATES AND GREAT BRITAIN, THE UNITED STATES PATENTS THAT HAVE EXPIRED AND THE REGISTERED TRADE-MARKS.]

UNITED STATES PATENTS.

ISSUED MARCH 17, 1908.

881,925. BRACELET. HARRY R. HOLBROOK, Attleboro, Mass. Filed Feb. 12, 1907. Serial No. 356,958.

In an article of the class described, a pair of crossed members, one of said members being piv-

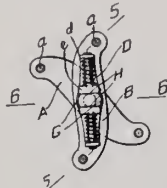

oted on the other of said members by a stud fixed thereon, a head on said stud having a plurality of diameters and a spring actuated part mounted on the other member coacting with said head.

882,062. COLLAR-BUTTON. DAVID A. HART, Attleboro, Mass. Filed Sept. 19, 1906. Serial No. 335,191.

An article of manufacture, consisting of a collar button, having a transversely perforated back containing a recess in its front side to fit and retain the shouldered base of the post, combined with a long slender post terminating at one end in a head,



and at its opposite end in a flaring shouldered base provided with a thin, flexible, integral prong extending transversely through said perforated back, bent into clamping engagement with the under side of the back and permanently secured thereto, said head, post, and back being irremovably fastened solidly together.

882,179. FOUNTAIN-PEN. EDWIN R. SMITH, Paris, Tex., Filed May 28, 1906. Serial No. 319,184.

In a fountain-pen, an ink-containing handle, pen blades pivotally mounted with respect to the handle, and a feed tube extending from the handle toward the points of the pen blade to feed ink to the

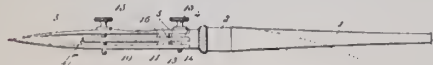

latter and disposed to permit the blades to be moved to one side to allow ink to be supplied to the handle through the feed tube.

882,186. SECONDARY ELECTRIC CLOCK. GEORGE B. BOWELL, Westminster, London, Eng. Filed Dec. 14, 1905. Serial No. 291,776.

In an electric clock, the combination of a rotary step-by-step operating device comprising an electro magnet, a double cam shaped disk mounted to rotate in the field of the magnet and actuated by

the magnet when energized, means for locking said disk against actuation, means for unlocking said

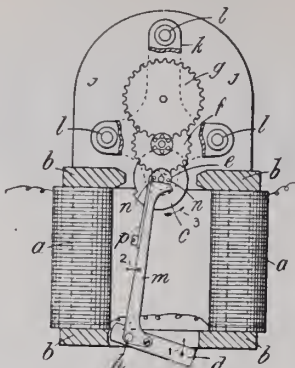

locking means and adapted to bring said disk into starting position.

882,320. FLASH-LIGHT ELECTRICAL ALARM AND BANK AND CALL CLOCK. AUGUSTA Y. JANSEN, Chicago. Filed March 9, 1907. Serial No. 361,563.

A device of the character described, comprising a clock provided with an alarm arbor, an electrical bell, a circuit for said bell, means connected with said arbor to interrupt said circuit, means for sup-

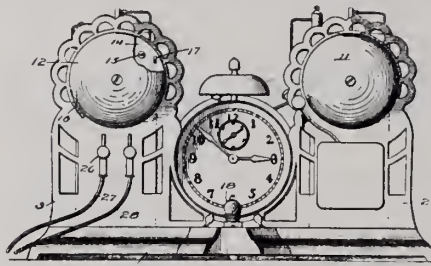

plying current to said bell, an electrical lamp, a circuit for said lamp, a circuit parallel with said first mentioned circuit, and a metallic push button switch for closing the circuit of said lamp when pressed and completing the circuit of said bell when pressed against said clock.

DESIGNS.

39,194. BADGE. FRANK PERSIC, Minonk, Ill., assignor of one-half to Jack Tomsic, Minonk,



Ill. Filed Jan. 20, 1908. Serial No. 411,822. Term of patent 7 years.

39,195. EMBLEM. FORREST E. MANN, Grand



Rapids, Mich. Filed Nov. 22, 1907. Serial No. 403,443. Term of patent 3 1/2 years.

39,196. EMBLEM. FORREST E. MANN, Grand



Rapids, Mich. Filed Nov. 22, 1907. Serial

No. 403,404. Term of patent 3 1/2 years. 39,197. EMBLEM. GEORGE H. MAISCH, Springfield, O., assignor to the Springfield Metallic



Casket Co., Springfield, O. Filed Dec 24 1907. Serial No. 408,199. Term of patent 7 years.

39,198. DECORATIVE PLATE. AUGUST J. F. DEVILLE, West Hoboken, N. J. Filed Jan



22, 1908. Serial No. 412,218. Term of patent 7 years.

39,199. MATCH-BOX. JULIUS J. KWIK, New Caldwell, N. J., assignor to SIMONS, Bro



Co. Filed Jan. 7, 1908. Serial No. 419,711. Term of patent 7 years.

UNITED STATES PATENTS THAT HAVE EXPIRED.

[Reported especially for THE JEWELERS' CIRCULAR-WEEKLY by R. W. Bishop, Patent Attorney Washington, D. C.]

Issued March 17, 1891

448,200. COMBINED CANE AND UMBRELLA. A. L. BRICE, Minneapolis, Minn., assignor of one-half to F. M. White, same place.

448,276. SHADE FOR SPECTACLES. J. STRANGE, New Bedford, Mass., assignor himself and J. B. Winslow, same place.

448,294. CIRCUIT-CLOSER FOR CLOCK. H. A. CHASE, Boston, Mass.

448,325. ALARM-CLOCK. E. M. FROST, Chicago.

448,360. FOUNTAIN-PEN. JOHN OLIPHANT, Toledo, O.

448,384. KEY-HOOK. ROBERT SPIERLING, III, Scheim, Germany.

448,409. NAIL-FILE. ISABEL CASSIDY, New York, assignor to the London Toilet Brush Co., same place.

448,428. BUTTON. F. F. HEILBORN, Plainfield, Mass.

448,510. ILLUMINATED CLOCK. A

- DUBOIS, Brooklyn, N. Y., assignor to Morris Hart, same place.
- 18,519.** CLASP FOR SUSPENDERS. C. R. HARRIS, Williamsport, Pa.
- 18,532.** CUFF-HOLDER. A. A. MEHAFFEY, Poplar Bluff, Mo.
- 18,549.** STOP-WATCH. CHARLES SCHLATTER, Hoboken, N. J.
- 18,560.** TIME-RECORDER. F. E. TYNG, Irvington, N. Y.
- 18,591.** METHOD OF MAKING PLATED WIRE. C. R. SMITH, Providence, R. I., assignor to the C. R. Smith Plating Co., of Kentucky.
- 18,610.** FINGER RING. CHARLES GOSLING, Brooklyn, N. Y., assignor to Stern Bros. & Co., New York.
- 18,617.** BRACELET. T. C. HUSON, Providence, R. I., assignor to G. L. Vose, same place.

- Designs issued March 13, 1894, for 14 years.*
- 3,108.** SPOON-HANDLE. J. H. ROCK, Bridgeport, Conn., assignor to the Holmes & Edwards Silver Co., same place.
- 3,110.** ASH-RECEIVER. W. H. O'DWYER, New York.
- 3,113.** DISH. C. E. HAVILANO, Limoges, France.
- Design issued March 10, 1901, for 7 years.*
- 4,240.** PLATE. C. J. AHRENFELDT, New York.
- Design issued Sept. 13, 1904, for 3½ years.*
- 7,127.** PAPER-CUTTER HANDLE. S. A. KELLER, New York.
- 7,128.** BUTTON-HOOK HANDLE. S. A. KELLER, New York.

UNITED STATES TRADE-MARKS.

[The following trade-marks have been adjudged entitled to registration under the Act of Feb. 20, 1905, and are published in compliance with Section 6 of said act. Said section provides: "Any person who believes he would be damaged by the registration of a mark may oppose the same by filing notice of opposition, stating the grounds hereof, in the Patent Office, within 30 days after the publication of the mark sought to be registered, which said notice of opposition shall be verified by the person filing the same before one of the officers mentioned in Section 2 of this act. If no notice of opposition is filed within said time the commissioner shall issue a certificate of registration hereof, as hereinafter provided for." Marks which are stated to have been "Used 10 years" are registrable under the last proviso of section 5 of said act, which is as follows: "And provided further, that nothing therein shall prevent the registration of any mark used by the applicant or his predecessor, or by those from whom title to the mark is derived, in commerce with foreign nations or among the several States, or with Indian tribes, which was in actual and exclusive use as a trade-mark of the applicant or his predecessor from whom he derived title for 10 years next preceding the passage of this act."]

PUBLISHED MARCH 17, 1908.

Ser. No. **20,103.** (CLASS 28. JEWELRY AND PRECIOUS-METAL WARE.) SAVARO & FILS, Paris, France. Filed June 7, 1906.

FIX

Particular description of goods.—Ornamental clasps, wedding rings, resilient split rings, and rings of all kinds for men and women, metal trimmings for alms-bags and purses, bracelets, lockets, charms and medals, chains of all kinds, necklaces, chaplet beads and crosses, pins of all kinds, shirt-studs, medallions, fobs, pencil-cases, letter-openers, handles for canes and umbrellas, crosses, and ornamental backs for mirrors, made of precious-metal ware.

Ser. No. **20,104.** (CLASS 28. JEWELRY AND PRECIOUS-METAL WARE.) SAVARD & FILS, Paris, France. Filed June 7, 1906.

TITRE FIXE

Particular description of goods.—Ornamental clasps, wedding rings, resilient split rings, and rings of all kinds for men and women, metal trimmings for alms-bags and purses, bracelets, lockets, charms, and medals, chains of all kinds, necklaces, chaplet beads and crosses, pins of all kinds, shirt-

studs, medallions, fobs, pencil-cases, letter-openers, handles for canes and umbrellas, crosses, and ornamental backs for mirrors, made of precious-metal ware.

BRITISH PATENTS.

(ABRIEGMENTS OF SPECIFICATIONS, 1906, FROM *The Illustrated Official Journal.*)

ISSUE OF MARCH 4, 1908.

25,348. WATCH STANDS OR HOLDERS. S. T. OLORIOGE, Regent Circus, London, Nov. 10. Watch stands or supports are so attached to the watch case that they can be folded up against the case and carried with the watch in the pocket. As shown in Fig. 1A, the watch is supported by a strut hinged to the case and adapted to lie flush with the case when folded up. The strut may be hinged to the lower part of the watch, or it may be in two parts hinged as shown in Fig. 7. A

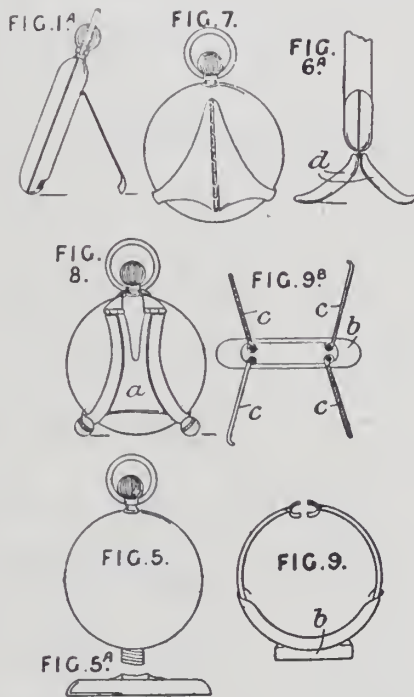

wire fitting round the outside edge of the watch may take the place of the strut. As shown in Figs. 5 and 5A, a spun cap fitting over the back of the watch is formed with a threaded hole adapted to engage with a screw fixed to the watch. In the constructions shown in Figs. 8 and 9, a separate holder is provided, having a supporting-strut *a*, Fig. 8, or a base *b*, Fig. 9, with four struts *c*, Fig. 9A, riveted thereto, and capable of rotation about the rivets. As shown in Fig. 6A, the support consists of a pair of plates *d* which fit flush into the watch case.

Complete specifications accepted Feb. 19, 1908. 1907.

- 3,371.** SAFETY RECEPTACLE FOR JEWELS. DEWEY.
- 3,439.** COMBINED TIE-CLIP AND COLLAR-FASTENER. MYERS & MYERS.
- 11,907.** TEA-INFUSER SPOON. BUSHELL.
- 15,307.** WATCH AND CHAIN PROTECTOR. FRASER.
- 15,461.** EYEGLASSES. REACH.
- 19,107.** WATCH MOVEMENT. DEGOUMOIS.
- 23,416.** ELECTRIC-CONTROLLED PENDULUM. FERY.
- Applications filed Feb. 10 to Feb. 15, 1908.*
- 2,903.** HAIR-WAVER. J. W. FINCH, Manchester.
- 3,074.** INKSTAND. G. H. STUFFIELD, London. Complete specification.
- 3,094.** NOSE-PIECE FOR EYEGLASSES. W. A. COATES, London. Complete specification.
- 3,125.** HAT-PIN. WILLIAM MAWLAM and S. R. HINGLEY, Stockton-on-Tees.
- 3,145.** INKSTAND. E. T. DARKE, London.

- 3,497.** SCARF-RING. H. E. HVOE, Birmingham.
- 3,256.** CANDLESTICK. C. N. UPTON, London.
- 3,387.** TIME-RECORDER. H. R. SANOERS, Catford, Kent.
- 3,449.** SPECTACLES. A. B. MIALL, London.
- 3,497.** WALKING-STICK. ANSEL BLANSTEIN and MARKS NAGER, London.

Complete specifications accepted Feb. 26, 1908. 1907.

- 4,891.** MATCH-BOX. TARDIEU.
- 10,313.** TEA INFUSER. SCHROOER.
- 16,085.** MATCH-BOX. WANKLYN.
- 21,944.** EYEGLASSES. NEWBOLO.
- Applications filed Feb. 17 to Feb. 26, 1908.*
- 3,566.** BUCKLE. WALTER STELZIG, London. Complete specification.
- 3,624.** WATCH-CARRYING BRACELET. AUGUST KIEHNLE, Manchester.
- 3,625.** CLASP. AUGUST KIEHNLE, Manchester.
- 3,631.** BELL-CHIME FOR CLOCKS. W. H. HOSCHKE, London.
- 3,672.** STUDS. ARTHUR OWEN and ALFRED ALLEN, London.
- 3,703.** CANDLESTICK. A. A. ROLAND, London. Complete specification.
- 3,742.** CARVING-FORK. J. A. SCHADLER, London.
- 3,870.** EYEGLASSES. S. T. LOUDON, London. Complete specification.
- 3,893.** SPOON. S. W. ABBOTT, Southall, Middlesex.
- 3,938.** TIME-RECORDER. CHARLES TRITON, Manchester.
- 3,994.** PHOTO-FRAME. FREDERICK WICH, London.

Utica.

Judge Ray, of the United States District Court, has granted a discharge from bankruptcy to William D. Oertel, former jeweler and optician in Syracuse.

After May 1 the Utica & Mohawk Valley Railway Co. will occupy all of the store now used as a waiting room on Bleeker St. J. A. Lockwood, the jeweler, is closing out his stock and will move elsewhere.

The C. J. Wells Co., at 122 Genesee St., will change hands on April 1, when Wm. A. O'Donnell and Edgar C. Boucher will acquire the interests of Mrs. Calvin J. Wells, who has conducted the business since the death of Mr. Wells several years ago. Mr. O'Donnell has been connected with the Wells store for 12 years, and he has been in the jewelry business for upward of 24 years. Mr. Boucher is engaged in the coal business.

Reports have reached here that S. Orbach, the former local jeweler who is a much-wanted man by his trustee in bankruptcy and creditors, has been located in Maine, where he has again engaged in business. Orbach's exact location is unknown, or an attempt to bring him here would be made, as proceedings were under way to punish him for contempt of court when he skipped out. Orbach's failure was a notorious one, and it was claimed that he had secreted jewelry and money from his trustee amounting to about \$15,000. He fought the bankruptcy proceeding until the creditors had practically established their charges, whereupon Orbach disappeared about two years ago and has been missing ever since.

Eugene Hallett, 1143 O St., Lincoln, Nebr., is holding an auction sale, and will remove to new quarters April 1.

Waltham Watches

The history of the WALTHAM WATCH COMPANY is the history of watch manufacturing in America. More than half a century ago this Company introduced a new principle in the construction of watch movements, and has ever since applied the most advanced methods, producing always the best watches in the world. The WALTHAM WATCH COMPANY has built within its own walls the marvelous machinery employed in making the 15,000,000 Waltham watch movements now in use

Waltham Watch Company

WALTHAM, MASS.

THE HOROLOGICAL REVIEW

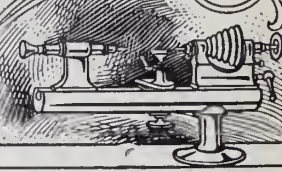

COMPENSATION THROUGH THE BALANCE SPRING BY EFFECTING AN AUTOMATIC VARIATION

THE best compensation of the effects of temperature on the regulating mechanism of a watch, is obtained with the aid of a special balance, known as a compensation balance. But if this balance is not constructed with the greatest care the working of its laminae under the influence of variations in temperature will often produce an effect contrary to that which is at first contemplated by the watchmaker.

close together as to materially obstruct this spring.

The other system, in which we vary the length of the active part of the balance spring, is not much better, because this variation in length does not allow of the isochronism of the oscillations. But this did not discourage inventors. The English horologist, John Arnold, had made use of this method as early as 1780, and LeRoy, having proved its deficiency from the point of view of isochronism, it was abandoned.

fect. The inventor, who is certainly not a horologist, has not worked out the details of its construction as a watchmaker would have done.

It is to be asked really how the ordinary relaxation of a watch operates; that which, independently of the variation caused by temperature, effects the displacement of the regulator. Further, a watchmaker would immediately want to know how the lever, *dr*, pivots above the jewel of the cock.

A more finished invention, as regards the details of construction, is shown in Figs. 2 and 3. There is no interference with the ordinary regulation by means of the shifting of the regulator and at the same time the regulation of the compensation is provided for.

This compensation is obtained by the variation in length, under the influence of the temperature of the metallic arc, *gk*, fixed at *g* to the arm, *a*, carried by the regulator. The arc, *g*, fits into a slide of

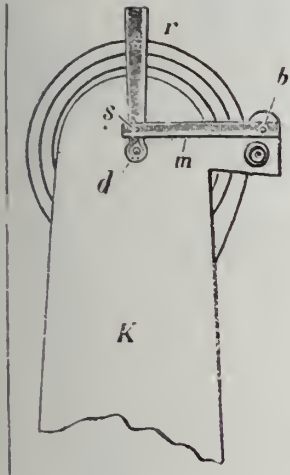

FIG. 1.

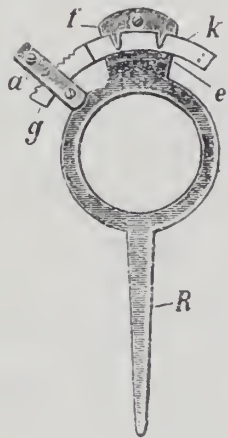

FIG. 2.



FIG. 3.

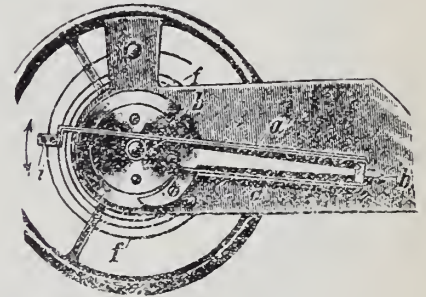

FIG. 4.

It is therefore only with the aid of a carefully constructed balance that we can best succeed in compensating the deviations or errors in rate, but such a balance costs too much to allow it to be used in a common watch.

For this reason, says the *Bulletin Manuel de l'Horlogerie*, certain inventors have returned to the system of effecting compensation through the balance spring itself and seek to correct the deviations in rate, due to the variations in temperature, by effecting an automatic variation, either in the active length of the balance spring, or by the distance of the curb pins.

We have already seen how compensation is obtained by effecting a variation in the distance of the curb pins; this system is defective, because the pins may be set so far apart that they are no longer touched by the balance spring, or they may be placed so

Modern inventors present it to us anew and take their patents: they have really no more than revised the principle in a more or less novel form.

In Fig. 1 is shown one invention. The rod *bs* is fixed at the *b* against the ear or wing of the cock, and at its extremity, *s*, it is fitted with a pin that enters a hole in the lever, *dr*, pivoted at *d*. This lever carries the balance spring buckle or "guard."

When the temperature rises the rod, *bs*, is elongated and its elongation, slight as it may be, causes a sensible displacement of the lever, *dr*, and, in consequence, of the guard. This displacement actually causes a shortening of the active part of the balance spring, and as a consequence accelerates the oscillations of the balance, although heat itself has a tendency to retard them.

This invention, by the way, could be per-

the arm, *a*, and a triangular pin, traversing this arm, enters into one of the other of the teeth cut on the edge of the arc, fixing it at the length demanded by the requirements of the compensation. At *e* the arc, *gk*, passes through a slide, constructed in the thickness of the regulator, as shown in Fig. 3, and is retained by a little plate, *f*, furnished with two prongs, forming a spring.

The part *g* of the arc is of brass and the part *k* of silver; the latter carries the pins, between which the balance spring works. The regulation of the compensation is thus readily obtained by the change in relation between the part of brass and that of silver and by the change of length in the complete arc.

The ordinary regulation, by shifting the curb pins, made as usual by the regulator itself, is entirely independent of the system of compensation.

It is the same in the system shown in our Figs. 4 and 5. As in the preceding sys-



18

16

12



These are the mystic numbers that have made such a heavy increase in the demand for

The G. M. Wheeler Grade **ELGIN WATCH**

Made for years only in the 18 size—it became so popular with people wanting an accurate timekeeper at a moderate price that we were actually *forced* to make it also in thin models—16 and 12 sizes. Result—a tripled business!

DON'T be satisfied with a third of your share—carry the three numbers and reap the full advantage of the Elgin advertising.

See jobbers' list for prices
or write the Company.

*Send for Elgin art booklets,
"Timemakers and Timekeepers" and "The Watch."*

ELGIN NATIONAL WATCH COMPANY,

Factories: Elgin, Ill., U. S. A.
General Offices: 131 Wabash Ave., Chicago.
New York Office: 11 John St.

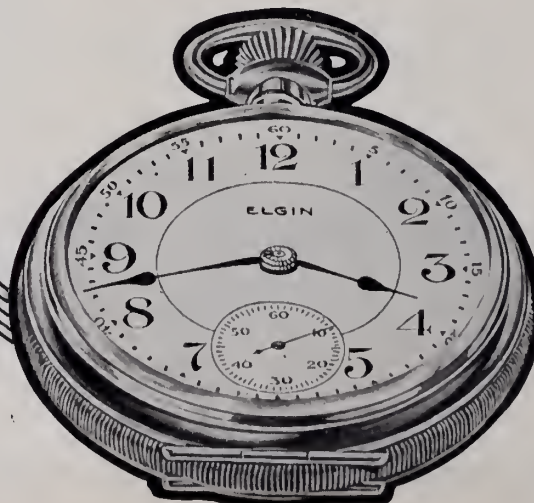

m, the regulator does not carry the regulating pins, these are adjusted to the end of bimetallic lamina, *a'*, connected by a small anverse piece to another lamina, also made of brass and steel, and which is attached by a nose to the regulator.

When the temperature rises the lamina, which is of brass outside, curves on the side of the regulator, and the lamina *a'* also acts in the same manner so that the extremity, *f*, is displaced and shortens the active length of the spring.

But as the arc of the circle traversed by

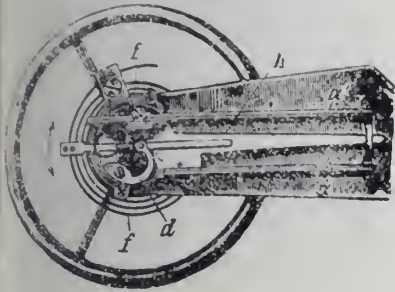

FIG. 5.

the pins has not exactly the same curvature as the first coil, *f*, of the balance spring, the inventor has devised another construction.

The compensating lamina, *a'* (Fig. 4), does not carry the pins; these are attached to the end of a lever, *h*, pivoting on a little ridge over the center of the balance spring. It is against this lever that the end of the



FIG. 6.

lamina, *a'*, works, and a little spring serves to insure the motion in one direction as well as in the other. Fig. 6 gives a side view of the contrivance.

“Old Timers.”

AMONG the curious clocks owned by Loren S. James, of Hallowell, Me., is one which was purchased in the year 1820. It is a good timekeeper, notwithstanding its age, and runs eight days with one winding. It was made by E. Taylor, of Roxbury, Mass. Another oddity consists of a timepiece purchased in 1825, which is still in good condition. Mr. James tells many interesting reminiscences of his early days in the trade. “When I began the business of repairing watches,” he said recently to an interviewer, “a watch that would run within three minutes in 24 hours was considered very satisfactory. The Swiss watches were then in general use, but the best watches were the English watches with their lever movements. One particular family in Liverpool made many watches under the name of M. J. Tobias. Some of these watches are to be seen to-day, but they are not used extensively as timekeeping instruments.”

Read the “Catechism of the Lever Escapement” now appearing bi-weekly in this department of the Circular Weekly.

Watch Repairing.

By H. REINECKE.

(Continued from issue of Feb. 26.)

WITHOUT intending to question the claims of any one in regard to the merits of the Breguet balance spring it may be asserted as an axiom that the relative points of attachment of any balance spring influence its isochronous property. Such being the case, correction may be made from this standpoint when an experienced adjuster is driven to such an expediency. The bending of a knee in the outer coil of a balance spring for the forming of an overcoil is decidedly objectionable as the forming of such a knee makes a rigid point, approximating an extra point of attachment.

The best mode of bending such an overcoil is the one employed frequently by English watch adjusters when applying Breguet springs to some of their fine watches. The *modus operandi* is as follows: Take a piece of brass wire of the size of about two millimeters and pierce a hole near one end, similar to the brass spring stud of an old English full plate watch, driving the other end into a small file handle. When drilled, broached and chamfered, take the outer coil of the spring through this hole and fasten it with a flat-sided pin, allowing about two-thirds of the outer coil to project on the free side. The outer coil can now be bent upward and inward in a flowing coil over the top to any height required without touching the other parts of the spring. For such a purpose several pairs of tweezers should be provided. Too much bending and subsequent unbending should be avoided as much as possible, as this would impair and damage the structural elasticity of the spring. The final end of the curve should be bent in a strictly circular form in order to correspond with the motion of the regulator pins.

The Breguet spring is perhaps the best form of the balance spring for a pocket watch when properly applied with the same care as any other form of a fire-hardened spring. In such forms it cannot very well be applied to small watches and its best results can only be obtained in large size gents' watches, for which such springs can be made on specially formed blocks with cut grooves.

A fine specimen of such was made by the writer in the year 1870, being a timepiece for the starting of ferryboats for the Central Railroad of New Jersey from New York City. As a fine pocket watch can be made on the same principle a description may be interesting. The escapement used for this timepiece was George Savage's improved lever escapement, described in “Britten's Watch and Clockmaker's Handbook,” on page 241. This escapement comes in its superior timekeeping properties more nearly to the chronometer escapement than any other.

The block for making the Breguet balance spring was made as follows: A contrate wheel of about three inches in diameter with 360 teeth, run by the spindle in the head-stock of a watchmaker's lathe and geared into a flat wheel attached to the cross leading screw of a slide rest. It is easily understood how a narrow cutter can cut a spiral groove in a flat disk. A

differential gear may be so adjusted that the coils of such spiral groove may be cut close or more open. It can also be conjectured how a Breguet balance spring can be formed strictly central as regards coils and collet and theoretically correct as regards the overcoil and can also be modified in every direction to suit circumstances. One of the greatest advantages of making a Breguet hairspring in this manner is that such a spring needs no altering of the overcoil, which remains strictly in the form in which it has been hardened and tempered.

The hardening is done in the same manner as some of the English helical pocket chronometer springs were hardened, which is as follows: They are encased in an iron tube and packed with charcoal dust. The tube is further incased in some kind of a sheet iron box and packed with small pieces of charcoal. After being slowly heated without a blower, it is cooled, when the proper glow is obtained, in a liberal supply of colza oil.

Colza oil is a kind of oil which is extensively manufactured in France and goes by the popular name of rape-seed oil. It is known to have the greatest affinity for oxygen of any oil known, which quality causes it to give a most brilliant light, when used in lamps for lighthouses. It might be difficult to explain the chemical reason why hardening imparts to steel such a high and desirable degree of elasticity, which has been so severely tested in the timepiece which I have made. This timepiece has been doing service up to the present time and has given eminent satisfaction.

(To be continued.)

Horological Notes.

A FRENCHMAN, named Alphonse Duhamel, Paris, has constructed a clock which is composed entirely of bicycles. The framework is a huge bicycle wheel around which are arranged 12 wheels of ordinary size, all fitted with automatic tires. The rim within the large wheel bears the figures for the hours, the figures themselves being constructed of crank rods. The hands are made of steel tubing, which is used for the framework of bicycles. The minute strokes on the dial are small nickel plated spokes. The top of the clock is an arrangement of 12 handle bars. The clock strikes the hours and the quarters, bicycle bells, of course, making the chimes. The pendulum is made of various parts of a bicycle frame. It is said that the clock, besides being a curiosity, is an excellent timepiece. It adorns one of the public buildings of Paris.

N. T. Shore, of Hope, Ind., has made a record for himself as a clock winder. Mr. Shore has wound the large clock in the steeple of the local Moravian Church for the past 25 years on an average of once every 24 hours. During this work of a quarter of a century he has never missed the performance of his task except once, and that was while he was serving on a jury. About 200 revolutions of the arm are required to wind the clock on the striking side, and 50 revolutions on the timing side, making a total of 250 revolutions a day, or a grand total of 1,329,250 since Oct. 23, 1873. The old clock winder is 65 years old and unusually active for his age.

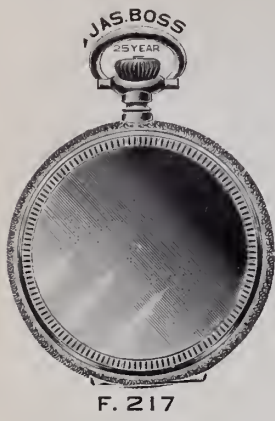

JAS. BOSS Stiffened Gold Watch Cases

(Guaranteed for 25 Years)



Trade-Mark in Back



Trade-Mark in Cap

- ¶ A few new models and designs in O size Hunting.
- ¶ All leading jobbers show these and hundreds of other styles in the various sizes.
- ¶ It will pay you to look over the "BOSS" lines, both in 25 year and 20 year.

THE KEYSTONE WATCH CASE CO.

PHILADELPHIA.

NEW YORK

CHICAGO

BOSTON

CINCINNATI

SAN FRANCISCO



Two Carved Stone Sun Dials of the 18th Century.

INCLUDED in the list of recent acquisitions at the Metropolitan Museum of Art, in New York, are two carved stone dial sun dials, of the 18th century.



OLD SUN DIAL HAVING ARABIC NUMERALS.

These quaint timepieces, which are illustrated herewith, were brought from London a short time ago.

The dial showing the figures of the two angels came from Somerset House, London,



ELABORATELY CARVED STONE SUN DIAL OF THE 18TH CENTURY.

and was brought from Europe about 100 years ago. As seen in the illustration, the two figures are seated at either side of the dial. One holds a book in one hand and supports a lamp in the other. The figure at the opposite side holds an hour glass in the right hand and Mercury wings, significant of the fleeting hours, in the left hand. The dial is graduated to show the hours. The face of the dial is about 14 inches wide and the gnomon 12 inches long. The dial is about three feet square. On its face is the inscription, "Life is but a walking shadow."

The other illustration shows a sun dial from the Old Bailey house, in London. It is also of heavy carved stone and the dial face is shown in Arabic numerals. About the face of the dial is a scroll and cord entwined in pleasing effect. The face of the dial is two and one-half feet wide. The outside dimensions of the dial are four and one-half by three and one-half feet.

The Competitive Trial of Chronometers During the Year 1907 at the Observatory of Geneva.

DURING a session of the committee on industry and commerce of the Society of Arts of Geneva, Jan. 27 last, Prof. Raoul Gautier, director of the observatory, presented an interesting report of the annual competition of chronometers. During the limited period of the year 1907 the number of chronometers presented for such trials was 311, against 377 presented during the year 1906. But this difference was caused by the fact that a larger number of chronometers of the second and third class was contained in the larger number, while 30 more chronometers of the first grade were contained in the smaller number (259 against 229).

The competition of the year 1907 shows the following results: Out of 259 submitted 58 were rejected and 201 received

above 230, 40 chronometers; above 220, 66 chronometers; above 210, 84 chronometers; above 200, 101 chronometers; above 180, 116 chronometers; above 160, 128 chronometers; above 150, 132 chronometers; below 50, 11 chronometers.

Serial Competition.

FIRST PRIZE.		
Points.	Manufacturers.	Adjusters.
254.68	Patek, Philippe & Co.	253.24 Batifolier.

SECOND PRIZE.		
Points.	Manufacturers.	Adjusters.
243.14	Golay, Sons & Stahl.	248.86
242.16	Vacheron & Constantin.	Golay-Audemars.

Isolated Numbers.

FIRST PRIZE.		
Points.	Manufacturers.	Adjusters.
262.8	Patek, Philippe & Co.	Batifolier.
57.3	Patek, Philippe & Co.	
54.5	Patek, Philippe & Co.	Golay-Audemars.
250.7	Vacheron & Constantin.	Batifolier.

SECOND PRIZE.		
Points.	Manufacturers.	Adjusters.
248.2	Galopin & Co.	Batifolier.
47.2	Golay, Son & Stahl.	Batifolier.
6.8	Patek, Philippe & Co.	Batifolier.
6.4	Patek, Philippe & Co.	Golay-Audemars.
5.9	Patek, Philippe & Co.	Golay-Audemars.
5.9	Patek, Philippe & Co.	Golay-Audemars.
5.3	Golay, Sons & Stahl.	Batifolier.
4.7	Patek, Philippe & Co.	Baud Bros.
4.6	Patek, Philippe & Co.	Golay-Audemars.
4.4	Golay, Son & Stahl.	Batifolier.
3.8	Patek, Philippe & Co.	Batifolier.
3.4	Golay, Sons & Stahl.	Batifolier.
3.1	Vacheron & Constantin.	Batifolier.
1.6	Patek, Philippe & Co.	Golay.
1.5	Vacheron & Constantin.	Batifolier.
1.2	Huning.	Henri Lossier.
1.2	Patek, Philippe & Co.	Batifolier.
240.2	Patek, Philippe & Co.	Batifolier.

THIRD PRIZE.		
Points.	Manufacturers.	Adjusters.
239.8	Patek, Philippe & Co.	Baud Bros.
8.6	Vacheron & Constantin.	Louis Lossier.
7.7	L. Gironde.	Batifolier.
6.9	Vacheron & Constantin.	Batifolier.
6.6	Patek, Philippe & Co.	Batifolier.
6.6	Patek, Philippe & Co.	Golay-Audemars.
6.0	Patek, Philippe & Co.	Golay-Audemars.
6.4	Golay, Sons & Stahl.	Batifolier.
4.2	Patek, Philippe & Co.	Baud Bros.
4.2	Patek, Philippe & Co.	Golay-Audemars.
3.0	Patek, Philippe & Co.	Golay-Audemars.
2.8	Patek, Philippe & Co.	Golay-Audemars.
2.0	Golay, Sons & Stahl.	Batifolier.
1.9	Galopin & Co.	Batifolier.
1.9	Patek, Philippe & Co.	Golay-Audemars.
1.7	Golay, Sons & Stahl.	Batifolier.
231.3	Vacheron & Constantin.	Batifolier.

Fourth prizes have finally been determined upon, according to which the house of Richard has received 18 honorable mentions and 17 simple mentions.

A watch which was shown recently to a jeweler at Fremont, Nebr., is reputed to have been made in 1758. Various marks on the case show that it has been repaired since 1805 in several shops in this country and in Europe.

A resident of Salina, Kans., owns a clock which it is claimed was made over 200 years ago. The clock is of the grandfather type, six feet high and attractively designed. It indicates, besides the regular functions of a timepiece, the days and the months and the different phases of the moon.

At the monthly meeting of the directors of the Harvard Co-operative Society, held recently, the project of placing a large clock in the front wall of the building to face Harvard Square was brought up. It is proposed to have the clock illuminated at night, and run by electricity on observatory time.

certificates of the first class. About 143 competitors took part in the competition. Thirty-five chronometers which belonged to strangers did not have the right to participate, and 23 from Geneva were withdrawn for various reasons.

The results have been most remarkable and constitute a great success for the horological industry of Geneva. In effect, the average result of the competition of 1907 excels any which have been stated up to the present time.

The following are the mean numbers of classification: Above 260, 1 chronometer;



SIDE VIEW OF WATCH.

DUBOIS Safety Chatelaine Brooch Watch

Patents Pending in U. S. and Foreign Countries

Made for O size, Jewel size and smaller watches in different designs and styles

Licensed under Wachter Patent Ball-Bearing Bow



RAISED VIEW.

MERITS

Holds the watch firmly and securely, thus preventing the movement from being jarred, as there is no swinging or bobbing up and down while the wearer is walking or running. Protects both the case and garment from wear.



DESK WATCH.

UTILITY

It can be raised so as to read the time, and reversed to have either the dial or back facing front, without removing brooch pin or watch from the garment. Can be worn on the shoulder, belt, chain or fob.

ARTISTIC AND PRACTICAL

The only brooch and watch combined. Affords absolute security, as it has a safety catch. Nothing to wear out, as it works on friction bearings. Eliminates the possibility of loss of the watch owing to either bow, hook, swivel or link wearing out, breaking or coming apart, as in the old style chatelaine. Does not interfere with either winding or setting of movement.



FRONT OF WATCH.



BACK OF WATCH.

Dubois Watch Case Co.

21 and 23 Maiden Lane
NEW YORK CITY

Railroad Watch Inspection and Its Relation to the Market for High-Grade Time-Pieces.

NEW YORK, March 16, 1908.

Editor THE JEWELERS' CIRCULAR-WEEKLY:
Inasmuch as there seems to be an attempt on the part of some newspapers to use all news relating to the recently proposed bill to regulate watch inspection in the time service of railroads (which has been introduced in two State legislatures) as an excuse to attack the time service generally, would it not be well at this time to call the attention of our subscribers to the fact that most of the articles which have appeared in the lay press have misrepresented the position of the jeweler, the railroad man and the members of the American National Retail Jewelers Association as to their attitude toward the time service systems now in vogue?

While it is true that there may be jealousy on the part of some jewelers against the local time inspectors, by reason of the fact that his position gives him the greater part of the business in watches from railroad men, nevertheless I do not hesitate to say that there are few, if any, sensible retail jewelers who are opposed to the time service systems, as such; nor can the expressed attitude of the organized jewelers be construed as attacking such systems. The National Association hurriedly and without debate passed a resolution favoring the introduction of a certain bill to regulate the railroad time service in the various States, but it is safe to say that the support given to this measure by the members generally, whatever it may be, is mainly in the belief that the bill is an honest attempt to perfect the time service and not to overthrow it. It was endorsed because the members did not *oppose*, but *avored* the time service system and wanted to make it as perfect as possible.

Of course, such action was born of the presumption that the bill would improve the service—a presumption taken for granted. Without evidence, though, as to the question of the bill accomplishing this object there already a difference of opinion among the people who at first supported it. In fact, many of those who supported it were even to believe that it was a measure of interest, not only to the jewelry trade, but to the railroad man as well, and that the latter desired it. They have learned since, however, by the official action of officers and the local bodies, etc., of the Brotherhood of Locomotive Engineers, and the Order of Railway Conductors and others, as well as by the expressions of opinion of such organs of the railroad trade as the *Railroad Trainman*, that no such action is desired by the railroad employes, and, in fact, they are opposed to any such measure as the bill in question.

There is now considerable doubt as to whether the State and national organizations will continue to push the measure, even in the belief that it may perfect the present systems, as it is evidently uncalled for, not perfect, and brings forward nothing new. If, on the other hand, the bell be rung on the significance that the daily papers

have given it, namely, that it is an *attack* upon the present railroad watch inspection systems and upon one or two prominent individuals who are identified with these systems, the supporters of the movement in the jewelry trade will not number a corporal's guard.

Why should the jeweler for a minute give support to anything that is going to attack, displace or cause a deterioration in the present standard established by the time service systems of the United States? These systems of watch inspection are maintained for the purpose of insuring correct and reliable timepieces in the pockets of employes who are entrusted with the responsible position of getting trains over railroads safely and promptly. Railroad watches are the most important safety appliances used in train service and the watch inspection department of railroads not only should appeal to the jeweler as a public-spirited citizen, but should also appeal to him from the commercial side as well, inasmuch as the inspection of railroad watches has been the greatest, if not the one great cause for the improvement and perfection in the grade of American watches for more than 20 years. In fact, ever since the Louisville & Nashville Railroad established the first watch inspection under Mr. Forsinger, the effect on the standard of American watches has been noticeable. To-day, with 180,000 miles of railroad in the United States and Canada under the watch inspection systems, the grade of watch movement that was accepted as a good watch 15 years ago is to-day considered but mediocre.

There is hardly a jeweler who fails to remember when a high grade watch, so called, was adjusted to temperature and only three positions. To-day it must not only be adjusted to temperature and five positions to meet the requirements and to be considered "standard," but the variation allowed in timing is considerably less than in those watches which would have passed muster as railroad watches some years ago. Many of the watches considered good timepieces 15 years ago would not be permitted to go out of the watch factory to-day.

The tendency of the standard has been upward and the watch manufacturers have been more than busy keeping pace with the increase in accuracy demanded by the railroad time service. Though the roads permit to-day a maximum variation of 30 seconds per week, it is well known that the watches carried by the employes as a whole run much closer.

Can any one for a minute doubt that this is purely a statement of cause and effect? Does not every intelligent jeweler realize that even though most of these railroad watches are sold by the time service inspectors, the effect of having 3,000,000 employes who belong to or are connected with our time inspection systems, cannot but have a marked effect on the demand for accuracy in timekeeping appliances upon the public at large, and indirectly cause the man in the street to realize the necessity of carry-

ing a timepiece up to the standard of those carried by so many railroad men.

It has been asserted that the one good market for high class watches is that built up and supported by the railroad companies and their employes, and if this market were taken away the sale of watches generally would soon drift to the seven jewel grade, the cheap clock-watch and the premium timepiece. I fail to see a denial of the statement. No, Mr. Editor, the jeweler realizes that the standard set by watch inspection systems of the railroad has done more to improve the "breed" of watches than ever the race track did to improve the breed of horses, and I understand that the improvement in the standard has helped, and continues to help, to put the jeweler's business upon a higher plane.

With nearly every railroad in this country and Canada under a watch inspection system, to fight watch inspection would be to fight against progress, as well as to fight against the prosperity of the watch trade, and the newspapers that put jewelers in a position of taking such a stand cast a reflection upon their acumen and even their sanity as business men.

If the authors of the bill which is being introduced into the State legislatures can show satisfactorily that the passage of the act would improve, strengthen and increase the watch inspection system, they may look to get support from the intelligent jeweler. If they cannot prove that it will do so, their motives will be regarded with suspicion and they will soon find that they must look elsewhere for support.

ONE WHO LOOKS ON.

Seals on Ancient Rings.

AMONG the rings found in ancient Egyptian tombs are many which erudite archæologists ascribe to a period slightly anterior to the Deluge.

This, however, is debatable ground—the deceptive morass of conjecture rather than the solid earth of fact. But we feel the latter beneath our feet when viewing the massive gold Egyptian signet rings with revolving cylindrical bezels of indigo colored porcelain or the deep blue porcelain rings bearing a bust of Isis or of one of the Pharaohs in full relief. The former represent the primitive seals in use when the Israelites were bondmen and before the Pyramids were built; the latter were the common adornments of the prototypes of the modern fellaheen when Solomon was in his glory.

In neither case is the workmanship meritorious, the "prentice hand" being plainly visible; skill in design and execution was acquired later, and among the Etruscans attained a degree of excellence never since equaled. Such of their work as remains is a silent yet eloquent testimony to their marvellous skill, but the secret that enabled them to manipulate gold "fine drawn as hair" is one of the lost arts of the ancients.

In the Etruscan as in the Egyptian rings the device of the scarabæus or sacred beetle figures prominently, for to both these remarkable races this curious insect was an object of profound veneration and as sacred and symbolic in their eyes as the cross is to the Christian.—*The Quiver*.

Repeated Triumph of the Patek, Philippe & Co. Watches

RECORD of 1907-1908

Kew Observatory Trial of Watches and Chronometers

The First, Second, Sixth, Seventh, Eighth and Ninth
BEST RECORDS

Geneva Astronomical Observatory Timing Contest

53 out of 101 Prizes, namely:

The only First Prize for Best Average Running among Makers

4 First Prizes out of 5

Including all the highest and the nearest to perfection ever obtained by a portable timepiece

10 Second Prizes out of 18

9 Third " " 17

12 Fourth " " 26

7 Honorable Mentions " 18

10 Single Prizes " 17

19 Manufacturers Participated

Awarded Hors Concours (Beyond Competition): Milan, 1906; St. Louis, 1904; Paris, 1900; Paris, 1889; Antwerp, 1885; Zurich, 1883.
Gold Medal: Nuremburg, 1905; London, 1885; Calcutta, 1883; Croningen, 1880; Paris, 1878; Vienna, 1873; Paris, 1867; Paris, 1855;
London, 1851; Paris, 1844. Diploma of Honor: Nice, 1883.

68 Nassau Street, NEW YORK

GENEVA, SWITZERLAND

New England

WATCHES

are cheap in price only. They are strictly high-grade timepieces, warranted to give entire satisfaction.

No Jewelry Stock is Complete Without Them

Write for price list and further particulars to

The New England Watch Co.

WATERBURY, CONN.

Chicago

San Francisco

The Favorite Movement with both Trade and Public



The Omega Movement

stands in high favor with the trade, and is constantly increasing in popularity for the reason that the public is quick to appreciate its merits.

The man who carries an Omega is proud of it and misses no opportunity to sound its praises to his friends. He finds it invariably and uniformly reliable. He learns to depend upon it and it never abuses his confidence.



Adaptable, Interchangeable, and Suited to all Requirements

The Omega is made in all sizes to fit regular American cases, besides a number of Swiss sizes. Every part is interchangeable, and all are made with lever escapements, double roller and pendant set. There are six different grades — from seven jewels to twenty-one jewels — adjusted to heat, cold, and five positions.

EDMOND E. ROBERT
3 Maiden Lane New York

WESTERN SELLING AGENCY
Omega Watches
Heyworth Building, Chicago

CROSS & BEGUELIN
31 Maiden Lane New York

A Page from Watch History

The picture at the left shows the old Roman tower in which the **Vacheron & Constantin** watch factory was located in the early days of watch history.



The picture at the right shows the present factory, built in 1875, and remodeled some years ago.

These illustrations not only mark the progress of the **V. & C.** watch, but of the entire watch-making industry, for the **Vacheron & Constantin** was recognized as the standard of excellence when the watch was first placed on the market in 1785, and is so recognized to-day.

It has always led in correct, scientific principles, in absolute accuracy, and in all the various improvements in watch manufacture since the establishment of the house. It has captured many first prizes in international timing contests, and its unquestionable superiority renders it the most salable and profitable high grade watch that the dealer can offer his customers.

The **V. & C.** line embraces every variety of adjusted watches, complicated watches, extra flat, ultra flat, and enameled, carved and jeweled watches.



EDMOND E. ROBERT, Sole Agent, 3 Maiden Lane, New York



The above TRADE MARK is well known to you, because it is on every watch and watch movement made by the LANGENDORF WATCH CO.

The more of our large line you carry in stock, the more profitable and satisfactory are

YOUR SALES

Perfect Interchangeability of parts renders repairing easy.

Do not accept substitutes, but insist upon getting the genuine L. W. Co. make. It's far the cheapest after all, as the quality is such you may

DEPEND UPON

If your jobber cannot supply you with

THE RIGHT KIND of GOODS

write to the Sole Agents for the United States,

AMERICAN-SWISS WATCH CO.

1 Maiden Lane, New York
CUSHMAN BUILDING

A.W.C.CO

Supplying a Demand



14K.
C-420

The best tribute paid to the line of moderate-priced cases that we are so vigorously exploiting is the widespread recognition already accorded them, indicating as it does a big and heretofore unsupplied demand for a really good and artistic gold case at a reasonably low price. For good looks and serviceability they recommend and sell themselves wherever displayed.

Sold by us directly to you

American Watch Case Co.

9-11-13 Maiden Lane

New York

AUDEMARS, PIGUET & CO.,

BRASSUS and GENEVA.

Manufacturers of Superior

Plain and Complicated Watches.

Represented by

A. WITTAUER CO.,

9-11-13 Maiden Lane,

NEW YORK.



THE R. & L. OIL

The R. & L. Oil is made especially for those expert watch and clock makers who must have the best and most reliable oil on the market. It does not gum or change, and possesses all the

requisites needed for the most delicate mechanisms. Send 25c. to your jobber, asking for R. & L. Oil.

Wholesale Selling Agents

M. SICKLES & SONS . . . Philadelphia
SWARTCHILD & CO. Chicago
NORDMAN BROTHERS CO., . . . San Francisco
D. C. PERCIVAL & CO. Boston
CHAS. MAY & SON Boston
DANIEL PRATT'S SON Boston

53 Franklin Street, Boston
SUSSELD, LORSCH & CO., . . . New York City
H. S. MEISKEY CO. Lancaster, Pa.

RANLETT & LOWELL CO.

SOLE MANUFACTURERS
Jewelers' Building BOSTON, MASS.

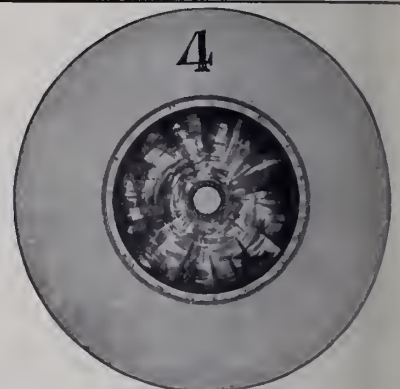

(Pat. applied for.)

Balance Hole Jewels Size of the hole numbered on setting. Saves time and duplication. You can order just what you want. If your jobber does not handle them, send to us. Made for all kinds of American movements.

Ruby and Sapphire, \$1.25 per dozen

THOS. J. JUZEK & CO., Elgin, Ill.

New England Watch Repairing for the Trade

GEO. W. HYDE & CO.

101 TREMONT STREET
BOSTON, MASSACHUSETTS

Make a Specialty of Repairing New England Watches

Work returned in one week, and guaranteed to be satisfactory in every respect. Recommended by The New England Watch Co.

Learn Watchmaking

Refined, profitable labor. Competent men always in demand. We teach it thoroughly in as few months as it formerly took years. Does away with tedious apprenticeship. Money earned while studying. Positions secured. Easy terms. See for catalogue. Address

St. Louis Watchmaking School, St. Louis, Mo.



**C. L. Guinand
Split Chronographs
with Minute Registers**

The Turfman's Standard.

Remarkable for accuracy and reliability. Are cased in Gun Metal, Silver filled and Gold. Prices reasonable.

Imported exclusively by

Jules Racine & Co.,

Importers of all grades of
Watches and Movements.

103 State Street, Chicago. 37 Maiden Lane, New York.

Ball Watches
THE RAILROAD STANDARD

The Watch Inspector's Friend

WRITE TO-DAY FOR OUR DEALER'S PROPOSITION

Minneapolis, March 12, 1908.

Gentlemen:
Your 18 size "Official" No. 548110 arrived just in time to aid me with my watch inspection work, as my electric clock was out of commission for 23 days, during which time your watch varied only 4 seconds.

Very respectfully,
L. L. WILLIAMSON.

Railway Watch Inspector
1717 E. Franklin Ave.

The Webb C. Ball Watch Co.

Ball Building
Cleveland

Railway Exchange
Chicago

Pacific Type Fast Express Engine for
New York - Boston Service.



HALL CLOCKS

Elliott's
Celebrated
Tubular
Chimes

**HARRIS &
HARRINGTON,**

12 BARCLAY ST.,
NEW YORK

Sole Agents to the Trade
for
J. J. ELLIOTT & CO.
LONDON.

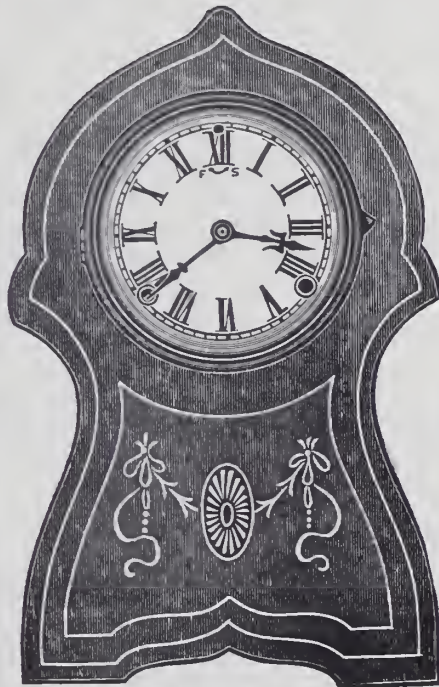

MANCHESTER

Height 13¾ in. Width 8¾ in.

**SESSIONS
CLOCKS**

Superior Finish
Popular Prices

We have added a number of fine marqueterie cabinet clocks to our line which will interest you.

**The Sessions Clock
Company**

FORESTVILLE, CONN., U. S. A.

New York Salesroom, 37 Maiden Lane

**WATCH REPAIRING
FOR THE TRADE**

Careful, Reliable, Prompt Work. Trade References. Price List on Request.

A. D. PAPAZIEN

71-73 Nassau St., Cockroft Bldg. NEW YORK

JULES JÜRGENSEN
Watches and Chronometers

PARIS—"THE GRAND PRIX"—1900

SOLE

RUDOLPH & SNEDEKER
65 Nassau St., New York

AGENTS

Buy Watches With Our Patent Ball-Bearing Bow

Already on the Market

No watch case should be without it.

BEWARE OF IMITATION

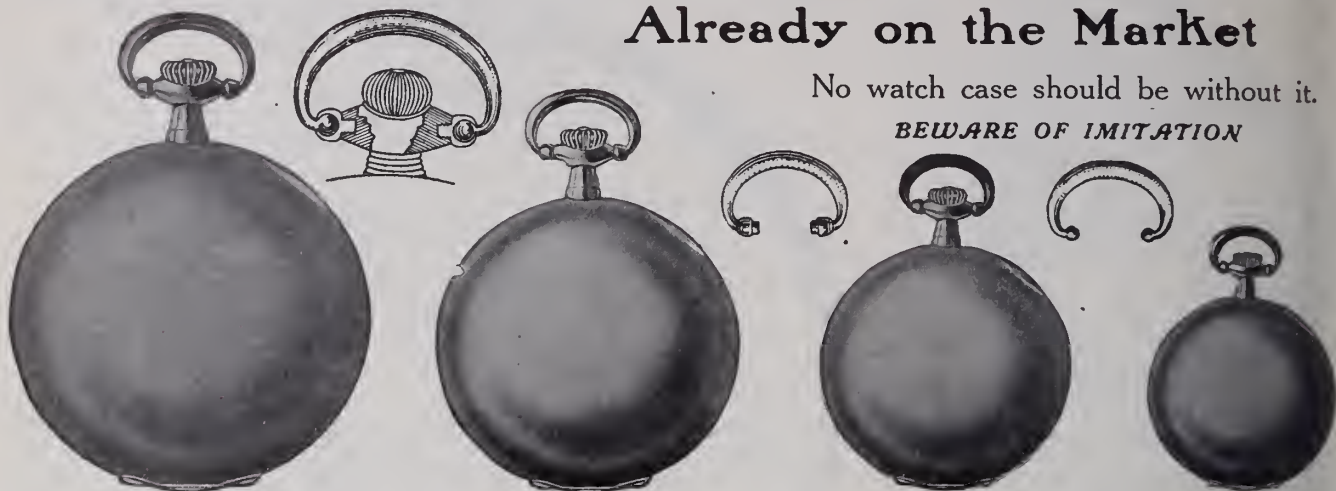

Should your jobber not sell cases with these bows, write us and we will give you a list of jobbers who do.
Patented July 25, 1905; May 21, 1907. Other patents applied for.
Patented in foreign countries.

The Wachter Manufacturing Co.
HARTFORD, CONNECTICUT

WM. C. PENFOLD CO.

No. 35 MAIDEN LANE, NEW YORK

LARGEST EXCLUSIVE WATCH JOBBERS IN NEW YORK OF

Dueber-Hampden Watches Dueber Cases — Hampden Movements

A Complete Line Always on Hand. Mail Us Your Orders

PRACTICAL COURSE IN ADJUSTING.

ALL JOBBERS OR JEWELERS' CIRCULAR PUBLISHING CO.

Published Price, \$2.50.
Special Reduced Price, \$1.50, Postpaid.

HOROLOGICAL DEPARTMENT

BRADLEY POLYTECHNIC INSTITUTE

Formerly Parsons Horological Institute

PEORIA, ILLINOIS

LARGEST AND BEST WATCH SCHOOL IN AMERICA

We teach Watch Work, Jewelry, Engraving,
Clock Work, Optics. Tuition reasonable. Boarding
and rooms near school at moderate rate.
Send for Catalog of Information



LEMAIRE OPERA GLASSES

LEMAIRE FIELD GLASSES

Best in the World. Used in the Army and Navy.

SUSSFELD, LORSCH & CO., Importers

37 MAIDEN LANE, NEW YORK

MARQUE DE FABRIQUE



All Genuine Glasses
Bear This Mark
Large Variety in All
the Latest Styles

to Jewelers who do *not* sell Ingersoll Watches

in times like these you can't afford to be without the live sellers.

Watches are always needed and naturally the lowest-priced reliable watch is the one that's selling heaviest *now*.

Conditions fundamentally are right for good business. Crops last season were \$320,000,000 more than in 1906. Cultivate trade by offering people the things they want now.

Ingersoll advertising is heavier than usual because the sales warrant it, and this, in addition to the window display material and *selling helps* supplied makes the selling of them easy and the volume large.

The prices are never cut and your profit will be good.

The watches are satisfactory in quality and will win friends for you.

If you are willing to do more business right now and if you are willing to examine samples of our four principal models at our expense

sign here

and we will send them together with our proposition to openminded jewelers who can judge what the people want when they think it over.



Robt. H. Ingersoll
& Bro.

You may send us samples of your four principal watches (which we are to have the privilege of returning within 5 days after receipt) together with your complete proposition to jewelers.

ROBT. H. INGERSELL & BRO.

45 John St., New York



STORE KEEPING DEPARTMENT

That this department shall prove mutually beneficial to our readers, it is desirable that the members of the trade generally communicate with THE JEWELERS' CIRCULAR-WEEKLY regarding any advantageous device or plan which they are utilizing in connection with their business.

Rolling Shutter Intended to Thwart the Efforts of the Ingenious Burglar.

MY place of business, says Ed. Zizler, in the *Deutsche Uhrmacher Zeitung*, has twice been entered by burglars. The first time, two years ago, the showcase was broken open and 25 cheap metal watches were stolen. The second experience was fortunately only an attempt, thanks to the vigilance of a dog that made such a noise that my landlord went through the ground floor, upon which the thieves fled through the transom over the house door, which they had previously left open, leaving be-

hind them a number of jimmys, etc. It may be stated, however, that they were shortly afterward captured in a neighboring city.

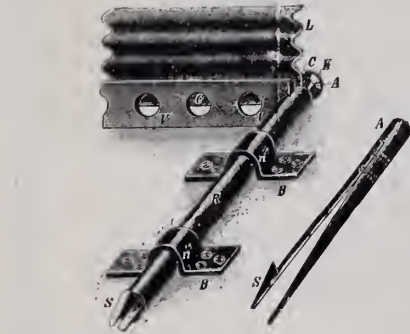

FIG. 1.

the center a keyhole D, the key to which propels, right and left, a suitable bolt E, into the masonry. In addition, there are inserted sidewise two strong bolts, of which, in Fig. 2, only the heads K K are shown, the further disposition of the bolts being shown in Fig. 1.

These bolts were made by a locksmith, according to my directions, and were each 6/10 of an inch thick and 15 inches long. In front there was a stronghead K; at the rear end a strongly elastic retaining hook S, was riveted on. As a guide for the shaft of this bolt a piece of iron water pipe R, about 7/8 of an inch in diameter was used. This is firmly fastened to it by means of two iron clamps B B, attached by screws

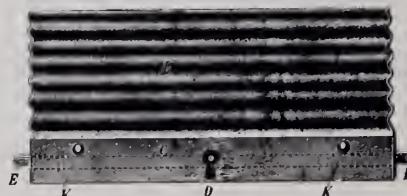

FIG. 2.

Although the second time I had suffered no loss, this later attempt at burglary was an intimation to me that one's place of business cannot be too securely protected. I therefore secured the doors with specially strong locks, heavy iron bolts and strong cross bars. Moreover, behind the glass light of the store door, I placed a heavy iron plate, and finally, I devised a means of protection against the raising of the rolling shutters of my three show windows, as illustrated herewith.

This contrivance, which consists in the main of a simple but strong bolt closure, can be made for any jeweler at reasonable cost, by an ordinary locksmith. Fig. 1 shows the bolt work, as seen from the inside of the show window, and Fig. 2 shows the outside of the roller shutter L, which is reinforced, at the lower edge, with a cross bar C. As may be seen, there is in

or rivets N N, to the bottom of the show window, and screwed on at such a height that the forward end of the pipe passes through a hole in the ventilating rail V, so as to reach quite close to the inner side of the rolling shutter L.

In the direction of this guide tube R, a hole is bored through the lower rail C, of the rolling shutter. When the shutter is pulled down, I first close the lock with the two cross bolts (e. g., Fig. 2); then I pass the bolts through the holes in the rolling shutter and the corresponding guide pipes behind which the retaining hook immediately snaps in, and I thus have a secure shutter.

The bolts can no longer be withdrawn from outside. On the other hand, when we desire to open them in the morning, by compressing the spring hooks S, on the inside, they can readily be pushed out.

This fastening is very easy to manage and at the same time durable. It has the advantage, moreover, of not being very conspicuous from outside, for the bolt heads

look like a couple of rivets on the lower cross rail. At any rate, this security serves to give me a special feeling of safety, and I shall be pleased to know that it has rendered similar service to others.

How to Meet the Competition of the Mail Order House.

(Continued from issue of Feb. 19.)

ONE of the greatest advantages the mail-order houses hold over the small merchant is the fact that they can advertise in a larger way. Their catalogues are a powerful advertisement, and are, of course, entirely beyond the reach of many small retailers to duplicate.

On the other hand, the retailers of most towns give them a better advantage in this direction than there is any need of, for the reason that they do not appear to grasp their own opportunities for advertising. Each one of them advertises in his own way, and as his business will not stand extensive advertising he must content himself with such kinds as are within his reach.

Right here is where a little co-operation would do wonders. If retailers will organize a business club and get close together in their own town, they will find many ways of helping each other, but probably the greatest opportunity such an organization gives is that of united advertising, especially the kind which tells them that you are not afraid of mail-order competition, and that you have the goods to look at and examine, and they do not have to take your word as to quality.

Some time ago the writer saw a well-written folder, which had been issued by a hardware man, giving reasons why his neighbors should patronize him in preference to sending their orders to a mail-order house in some far-away city. The advertising was the right sort, and was worthy of a great deal wider circulation than he was probably able to give it. In the entire booklet he did not advance a single idea or argument which would not apply with equal force to every other store in his town and if all of the retailers had banded together to issue this kind of advertising matter they could have sent out 10 times as many, and the expense would have been very light when divided up among the individuals. At the same time all the arguments would have had even a better effect upon those who received the booklet, because they would then have been received as the argument of a body of men instead

Storekeeping Department.

of only one. Numbers, you know, add weight to an argument.

There is always an opportunity for something new along this line, and a business organization in your town could do much in this way to build up a good-fellowship feeling between the business men and their customers, both in the city and in the surrounding country.

This part of the work can be more appropriately done by such an organization than by the individuals, so long as it is of a kind which is for the benefit of all alike, and in order to carry out such work effectively your club or association should provide itself with a mailing list which covers the entire territory which should trade with you. Such a mailing list should cover every house in the territory, and should be kept up to date all the time; then you know all customers and prospective customers are being reached at regular intervals with printed matter which should make them take a stronger interest in your town and its retailers, and you will find that if you can create this interest for the town you will be able to get your share of the trade when persons visit the town.

Do not go to the extreme in this class of advertising, and think because you can reach every home with circulars that there is no use putting an "ad" in the local papers. You could make no greater mistake than that. Keep your "ad" there all the time. That is the place for each retailer to show his own individuality in advertising, and persuade those who come to town to come to the store before leaving. Your local papers are your very best trade builders. But you must support them properly, and help them by making your advertising interesting.

F. A. P.

(To be continued.)

Clinching a Sale.

It happens not infrequently that an employer is deeply puzzled because of a certain clerk's failure to bring results. He has perhaps watched his work and can discover no good reason why the number of sales accruing from the efforts of the clerk are so small.

He seems to possess all the essential points of a capable salesman, is thoroughly satisfactory as to his attitude toward customers, while his willingness, interest and knowledge of the business are all plainly shown in the judicious and skilful manner in which he shows the goods and explains their worth. Yet in spite of this and the fact that his customers are apparently interested, they walk out without making the expected purchases.

What this clerk lacks is the power to clinch his sales—a quality very necessary to success and equally difficult to acquire. Nor is it easy to analyze this subtle influence that brings a customer to a definite decision to buy an article under consideration. It is not necessarily the product of experience, for young clerks often possess it to a marked degree.

Some people seem to recognize intuitively just the moment when a customer is at the

parting of the ways. Such people not only feel instinctively just when this moment is at hand, but know exactly what tactics to adopt to bring the transaction to a satisfactory conclusion.

It would probably be difficult for them to explain how they are able to do this, their methods varying according to those with whom they are dealing, but they would tell you that their own personality and force of will play no small part in clinching sales. One of the crudest substitutes for this real ability to conclude a sale is seen in the clerk who openly urges the buying of an article. Forcing the sale of goods in this way is always an unwise policy that results rather

This Attractive Store the Result of Nine Years' Hard Work.

ILLUSTRATED herewith is the attractively furnished store of Boasen Bros., Oklahoma City, Okla. The store is 65 feet deep and 24 feet wide. Back of the partition is a room 24 by 25 feet, which is used as workshop and storeroom. The show windows are 3½ feet deep and 6½ feet wide. Their attractiveness is enhanced and their dimensions exaggerated by means of large mirrors placed in the background. These mirrors are set in a frame with a paneled back and arranged with pulleys and weights so that they may be raised easily,



INTERIOR VIEW OF THE STORE OF BOASEN BROS., OKLAHOMA CITY, OKLA.

in losing than gaining trade, for a customer naturally resents this treatment and forms a dislike for the too officious clerk.

His influence need be none the less strong because it is unobtrusive. Let him remember that his aim, if he really would do effective work, must be to create in another an actual desire to possess his wares strong enough to prove irresistible, and that other must be allowed to depart carrying away with him, in addition to a neatly wrapped parcel, the comfortable impression that the exercise of good judgment alone is responsible for his purchase.

Just how to help an undecided customer to make up his mind must be left to each clerk to work out for himself, and unless he is willing to waste the fruits of much good preliminary work he will study the art of clinching sales.

M. G.

C. W. York, who claimed to live in Kingston, Ont., was recently arrested in Oswego, N. Y., where he fraudulently secured from a jeweler two gold watches which were later found in a second-hand store.

B. U. Tapken, New Brunswick, N. J., will soon occupy a handsomely furnished store which is being erected for his use. The new building will be of yellow pressed brick and iron, fire proof and thoroughly modern in every detail.

thus giving ready access to the contents on display at any time.

The fixtures are of light mahogany and plate glass. The wall cases consist of several cases, each 10 feet long, with a mirror 2½ feet wide between each one. There is also a circular-shaped show case in the front of the store, four 10-foot display cases and two eight-foot floor cases, besides a display case for watches and an umbrella case.

The front of the store, above the show windows, is of prismatic glass, which makes the room very light in the daytime. For illumination at night the concern uses the F. P. gasoline system. Both this and electric lights are used in the show windows.

This attractive establishment is the result of only nine years of hard work and enterprise. The business was started with a single watchmaker's bench and two small show cases of jewelry, and has grown steadily from the beginning.

The Bastian Bros. Co., Rochester, N. Y., is sending out to a selected list during the month of March, attractively printed post cards showing the birth stone and the flower for that month, both being printed in their natural colors. The card also calls attention to a clock which the concern is featuring and selling at a low price.

1 2 3 4 5 6 7 8 9 0 1 9 0 8 A B C D E F G H I J K

Alphabet and Figures

FOR CLASS RINGS, EMBLEMS, ETC..

HERPERS BROTHERS,
SETTING MANUFACTURERS,
Newark, N. J.,

1 9 0 8

1 9 0 8 A B C D E F G H E T C . 1 9 0 8

JANITSCHKEK COMPANY, Inc.

33 UNION SQUARE, NEW YORK CITY

Manufacturers of Patented **DIES** for the Silver and Metal Trade

ARTISTIC CASTINGS OF EVERY DESCRIPTION FOR THE SILVER AND JEWELRY TRADE

Iron Hubs and Bronze Forces, False Core Work and Undercut Castings with Elastic Patterns. Fine Plaster Castings by the *Janitschek Patent* Superior to the Asbestos Process

TELEPHONE, 400 STUYVESANT

These well-known Razors, the quality of which is warranted, possess this great advantage, that they may be used for ten years before they require actual sharpening. Before using them it is necessary to rub them on good leather strop. Le Coultre's Stropps (to be had with the Razors) should be used in preference to others.



THIS CUT IS TWO-THIRDS OF REGULAR SIZE.

"SPECIAL"—Single Razors for Jewelers' Travelers at trade price.

MATHEY BROS., MATHEZ & CO.

Send for Price-list.

Sole Agents, 21 & 23 MAIDEN LANE, N. Y.



HERMAN KOHLBUSCH, Sr.,

ESTABLISHED 1859.

Manufacturer of Fine Balances and Weights for every purpose where accuracy is required.

Office and Salesroom, 194 BROADWAY, NEW YORK.

Send for Price List.

Tel. 370 Cortlandt.



ESTABLISHED 1886

GEO. M. BAKER

TELEPHONE UNION 1493-R

Gold and Silver Refiner and Sweep Smelter

Office, 91 Page St.
Works, 77-85 Page St.

PROVIDENCE, R. I.

Our processes are strictly up to date and facilities most complete for doing all kinds of refining. Specialties: Prompt and good returns.

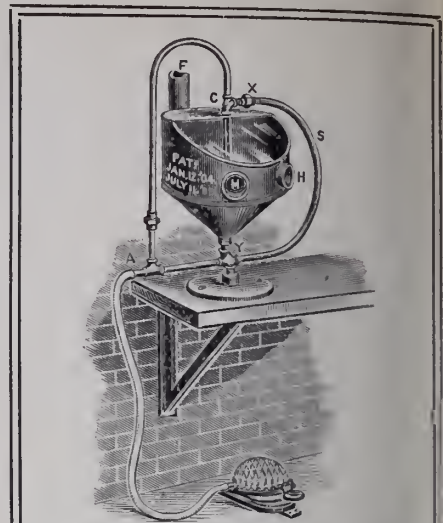

A Small Compound Sand Blast

Price, \$20.00

Foot Bellows, \$6.00

WORKS AS EFFECTIVELY WITH FOOT BELLOWS AS WITH POWER BLOWER :: :: ::

MADE of Galvanized Sheet Iron, 10 inches diameter, Glass Top, Fittings of Brass and Iron, practically indestructible. Satisfaction guaranteed. Ask your Jobber for it, or write to us. Other Specialties: Zeuner's Best Jewelers' Saws; American Swiss Files, equal to the best imported; Gas Furnaces, for Melting, Annealing, etc., etc.; Positive Pressure Blowers.

E. P. REICHELME & CO.
JEWELERS' TOOLS, FILES AND SUPPLIES
24 JOHN STREET, NEW YORK

Importer and Manufacturer of WATCH MATERIALS, TOOLS, JEWELERS' SUPPLIES AND OPTICAL GOODS



Bargains in Staking Tools

Prices on Application

Fine Gold, Silver and Platinum always on hand. Highest Prices paid for Old Gold and Silver.

A. ZAREMBOWITZ
250 East Houston Street NEW YORK

CASTINGS Gold, Silver, Bronze, Brass German Silver, Copper and Iron. L.D. TEL. 2072 L. Supply Jewelers, Silversmith Die-makers, Mould-makers, etc. Bronze Forces, Ha Bronze and Iron Shells for Die-cutting Machine Cast Iron Hub for sinking in Steel Dies. Chandelle Undercut Work, Statuary.
AUGUST GRIFFOUL 313 HALKEY STREET NEWARK, N. J.



WORKSHOP NOTES AND QUERIES

Answers are also solicited from our readers to the questions published on this page.]

QUESTION No. 2094.—Making Rings with Hammer.—How can a jeweler who has only a few tools make a plain ring, or make a piece to be used for enlarging a small one? T. M.

ANSWER:—A band ring can be made by first taking a square piece of steel and rolling into this, with a half-round file, a groove the size of the band wanted; then polish out and secure in a vise or hold it securely in some other way. (See illustration.) A piece of gold should be forged or rolled into a strip, heated, and with a ham-

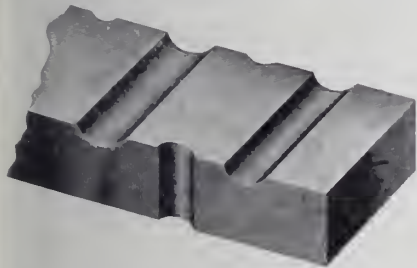

A STEEL RING FORGE.

mer forged into the groove in the steel. When the metal becomes cold it should be heated again and the forging continued until a small even band is obtained. By having grooves of different sizes in the steel a heavy or a thin band may be forged, as required. The right length is obtained and the band ends are filed tapering, so they will overlap for soldering. Shape up on a mandril and solder the joint. After this file smooth and proceed to polish. After a few experiments one can make and complete a ring in one hour. The forged rings are better and more durable than the cast or rolled ones.

QUESTION No. 2095.—Setting Stones in Celluloid Combs.—How can I best set stones in celluloid combs and prevent them from falling out? S. S.

ANSWER:—To set stones in celluloid combs no cement need be used, but the holes should be drilled in the comb so that the stone will fit snugly and can be pressed in place with a suitable pair of tongs. To make the stones more secure, warm the celluloid until it will bend with the fingers, drop a little acetone in the hole, and after a few moments press the stone into the hole. The acetone has softened the celluloid and some of it will form a wall around the edge of the stone. When dry, this will prevent any stone from dropping out or getting loose.

QUESTION No. 2096.—Black Filling and Ivory Stain.—Kindly give me formula for making a black filling for ivory; also a good black stain for the same. B. F.

ANSWER:—A black ink may be used for filling in engravings on ivory. This is produced by using the Normal ink, which contains nitrate of silver, 10 parts; distilled water, 100 parts. Lighter shades may be obtained by adding more water. Ivory stain is made with finely crushed gall nuts, one part; pulverized verdigris, four parts; water, 30 parts, by weight. Boil all together, then strain and bring to a boil again. The ivory is immersed in the above. Then immerse in a solution composed of one part of campeachy wood extract (tied in a linen bag); 0.5 parts acetate of iron, 0.1 part gum arabic, 12 parts water, one-twelfth part alum, boiled for one hour and strained.

QUESTION No. 2097.—Solution for Matting Aluminum.—Please give me a formula for producing a fine matt and white color on aluminum match safes and pin trays. S. F.

ANSWER:—To produce a fine, even matt on aluminum it is necessary to give a good polish, then dip for a few moments, or until the aluminum begins to show great chemical activity, into a nearly boiling solution of potash. Remove as quickly as possible and dip into a solution composed of two parts nitric acid to one part sulphuric acid, to which add a handful of salt. Dip into this second solution for about one-quarter of a minute, then rinse in water and dry in warm sawdust.

QUESTION No. 2098.—To Produce Small Silver Castings.—How can I alloy silver so I can obtain solid small castings without blistering or pores? T. P.

ANSWER:—To obtain good solid silver castings it is advisable to alloy the fine silver with from one to five parts of chemically pure zinc to 100 parts of fine silver. The molten silver should not be overheated, and must not boil or show blisters. If it does the castings will show pores. The zinc should be stirred in just before pouring into the mould. There is one advantage in alloying silver with zinc in place of copper, and that is the articles made therefrom will not blacken the hand or finger if worn. This alloy is therefore preferable for umbrella or cane handles, bracelets or buttons.

QUESTION No. 2099.—Repairing Discolored Pearls.—How can I refinish several pearls that appear discolored and spotted as if by ink stains? The pearls are drilled and filled. R. D.

ANSWER:—A diluted sulphuric acid solution will remove these spots in many cases. This will give the pearl a reddish tint. The most advisable way is to secure the pearl in the lathe, and with a very fine powder

polish to a fine finish, which will also remove all the spots. Then refill with plaster; when dry, redrill the hole.

QUESTION No. 2100.—Cleaning Gilded Part of Swiss Watch.—How can I clean the gilded parts of a watch without scratching the matted surface? C. G.

ANSWER:—To clean gilded parts of a watch, or any other frosted gilding, proceed by washing in warm water and soap to remove all grease and dust, then rinse off in hot water and dry. Take a clean brush (one having the bristles worn thin so they will be soft) and use a little carbonate of lime; then brush over the gilded parts and this will impart a brilliancy and fine appearance. This treatment will prevent scratches on the frosted gilded parts.

QUESTION No. 2101.—To Stiffen Softened Gold Wire.—How can I best stiffen gold or gold-filled wire on pins and brooches that have become soft during soldering? C. W. K.

ANSWER:—Softened gold, gold-filled, brass or steel wires can all be stiffened by hammering. This can be done with a small, smooth-faced hammer on an even stake. If hammering is not permitted, a burnishing tool may be passed over the wire. Turn so that it will burnish all around. Polishing on a hard revolving leather or felt wheel, on the polishing lathe, will materially harden the surface, but not as well as light hammering would.

QUESTION No. 2102.—Flux for Soldering.—What can I use as a flux for soldering silver? I also want one for soft solder. F. S.

ANSWER:—Powdered borax is the best flux to use for soldering silver. Make into a paste with water and apply to the parts when ready to solder. For soft soldering the chloride of zinc is good. Glycerine and muriatic acid, mixed, are also much used.

To Test Cements.

CEMENTS are tested to determine (1) their fineness, (2) setting, (3) soundness, (4) specific gravity, (5) strength.

(1) Fineness is determined by passing the cement through sieves of various meshes and noting the percentages retained.

(2) Setting is determined by making pats of the cement and noting the time before they resist penetration of wires of specified weight.

(3) Soundness is tested by noting the condition of the edges of the pats; also by heating pats with steam and seeing if they blow or crack.

(4) Specific gravity is determined by the comparison method.

(5) Strength is determined by preparing briquettes and permitting them to remain in air and under water specified periods, and then breaking them in a testing machine and noting the breaking load.—*Technical World Magazine.*

Bert Ganz, traveling representative for an eastern firm, and a recent visitor to Duluth, Minn., has been endeavoring to locate a trunk containing \$3,500 worth of jewelry stock, which is believed to have been lost in Chicago.

C. DORFLINGER & SONS

36 MURRAY STREET

NEW YORK



Hand-Made Blanks only.
Cut, engraved and etched
glass. Light, medium
and heavy stemware,
tumblers, etc.

The Pairpoint Corporation

NEW BEDFORD, MASS.

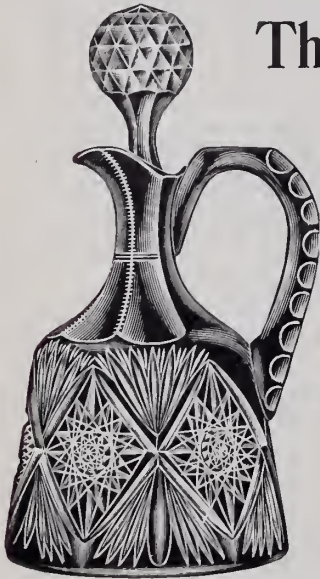

SUPERIOR
SILVER PLATED
WARE

RICH
CUT GLASS
WARE

ELECTROLIERS
GAS PORTABLES, ETC.



No. 4935.—Smoking Set.

BRANCHES

No. 692.
Whiskey Jug.
"Uncatena."

38 Murray Street - - - NEW YORK CITY
717 Market Street - SAN FRANCISCO, CAL.
485 St. Catherine Street - MONTREAL, P. Q.

Mr. Jeweler:

Do you know that hun-
dreds of your competitors
in all parts of the country
are making a specialty of
Fans? Do you know that
even a small line of Fans,
properly displayed, will
"dress up" the whole ap-
pearance of your stock?
Of course, the Fans them-
selves must be suitable
for jewelers, and must be
bought from one who
thoroughly understands
the requirements of your
trade. There is but one
such house in America—

Louis Steiner

ESTABLISHED 1870

F A N S
and Novelties for
the Jewelry Trade

520 & 522 Broadway
New York

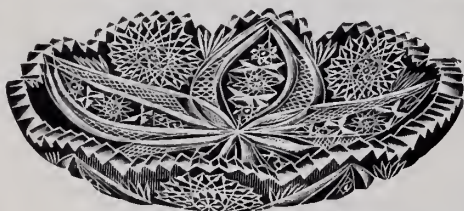

7 in. Saucer, Pansy No. 205

Artistic Designs, Graceful
Shapes, Excellent Workman-
ship and Unsurpassed Finish
together with Moderate
Prices explain the Popu-
larity of our line.

SEND FOR CATALOG

KELLY & STEINMAN, Inc.

Manufacturers of RICH CUT GLASS

HONESDALE, PA.

Irving Cut Glass Co. Inc.

Manufacturers of

Artistic Cut Glass

HONESDALE, PA.



"Wild Rose," No. 122—14-inch
Ice Cream Tray

F. W. REICHENBACHER
New York Representative
No. 25 WEST BROADWAY, Room 43

Established 1879

Manufacturer of

LOUIS W. HRABA  **Fine Leather Goods**

29 East 19th St., New York

Exclusively for the Jewelry Trade

CROUCH & FITZGERALD



**Jewel
Trunk
and Case**

177 Broadwa
Bet. Cortland
and Dey St
688 Broadwa
723 6th Av.
New York

THE CONNOISSEUR

Devoted to Art Pottery, China, Marbles, Bronzes, Cut and Decorated Glass Ware, Bric-à-Brac, Lamps, Art Metal Wares, Fancy Goods and Kindred Lines.

AUSTRIAN PORCELAIN AND VIENNA WARE.

(J. A. R. in the *Canadian Pottery and Glass Gazette*.)

THE successful establishment of the manufacture of porcelain at Meissen, under Augustus II., Elector of Saxony, under the Emperor Charles VI. with the desire to see a similar industry established on his own capital, a wish which he caused to be publicly announced. The idea was taken up by Claudius Du Paquier, a Dutchman in the Imperial service. He forthwith studied the literature written by missionaries in China on the subject, to gain all the knowledge obtainable as to the properties and ingredients of true porcelain, and felt confident of finding the necessary clay in Austria. His endeavors, however, soon proved to him that without further assistance he would be unable to obtain any satisfactory results, and the help he needed was only to be had in Meissen.

Through the Imperial Ambassador, the painter and guildler, Konrad Christoph Hunger, was induced to forsake Meissen and give his services to Vienna. Hunger worked with Du Paquier for about a year from the end of 1717, but their efforts being till destitute of practical results, Du Paquier induced the Meissen arcanist, Samuel Stenzel, with lavish promises, to forsake his work and come to Vienna. Even with his additional assistance their efforts still failed to attain the desired end, and it was not until they were able to obtain the kaolin clay from Aue in Saxony, which was used at Meissen, that porcelain was manufactured in Vienna. The actual foundation of the factory may be said to date from the 27th of May, 1718, when letters-patent were signed by the Emperor giving Du Paquier and his partners the exclusive privilege of manufacturing porcelain in the style of that of the East Indies and other foreign countries.

The public taste did not at first, as in Saxony, become enthusiastic with the new industry. The burghers were quite content with their faience or enameled earthenware vessels, the nobility continued to prefer their silver plate, and the people of moderate means found the new vessels much too expensive as compared with earthenware. Under these circumstances it is not surprising that a financial crisis soon arrived, which ended in the practical bankruptcy of the undertaking. Du Paquier at length found in 1744, after 25 years' working, that it would be impossible to continue the establishment as a private factory. Every year saw an increase in his financial liabilities without any proportion-

ate increase in the sale of the productions. He was compelled therefore either to close the factory or to induce the government to take it over. He was fortunate enough to be able to carry out the latter alternative, and in 1744 the State became owner on payment of 45,519 gulden. (A gulden is equivalent to two shillings or about 48 cents.)

The productions of the period, 1718-44, are by no means to be identified with any certainty. The factory, which was strictly a private enterprise, was never, like Meissen, patronized by the court and nobility; hence, the productions were for the most part only such as would be used for domestic purposes. However, a few specimens in the Austrian museum have been identified as belonging to this period. There can be little doubt that the earliest productions were copied from Oriental originals, as there were no models obtainable, but this style speedily gave way to that of the late Louis XIV. period. Gilding was also much used, and very low relief decoration is often met with.

Notwithstanding the fact that the factory had become a government institution, and was therefore on a very much firmer basis than when it was merely a private enterprise, it continued for many years to work under difficulties. The new director, Franz Karl Mayerhofer, had by the year 1750 increased the staff from 20 workmen to 40, and 11 years later the staff numbered 140, which again increased till, in 1780, 320 persons were employed. In the meanwhile the factory buildings were enlarged in the same proportion. Mayerhofer was succeeded in 1758 by Joseph Wolf, who remained as director till 1770, when the Hofrath von Kessler succeeded him. The latter appears to have been pursued by adversity in all his undertakings, and his bad luck still clung to him when he took over the Vienna porcelain factory. In his attempts to imitate the whiteness of the paste of the productions of Sevres and Meissen, he lost large sums in unsuccessful experiments, while he at the same time caused still heavier losses to the factory by increasing the output far beyond the demand, and by creating new depots for the sale of the porcelain in the various large towns of the Empire. With the year 1779 came a great depression in trade throughout the country, caused by the war, the effect of which was severely felt by the factory. Another adverse cir-

cumstance was the change of fashion from the rococo style of decoration to the classical, which soon made the accumulation of the stock of productions almost unsalable. These difficulties and the general unsatisfactory condition of the factory, determined the Emperor to reconvert it into a private undertaking. With this object in view it was offered for sale by auction on the 20th of July, 1784. No buyer, however, was found to offer the reserve price, and the factory remained on the hands of the government.

Baron Konrad von Sorgenthal was appointed director of the factory in 1784, but with much fuller powers than his predecessors. The factory soon felt the effect of the new administration. The staff was forthwith reduced from 320 to 280, but within a very few years it not only more than regained the prosperity of its best days, but also attained a high position in artistic origination. Sorgenthal, having placed the factory in a sound commercial position, was soon able largely to increase the number of his employes, and in 1799 no less than 500 hands were busily engaged. Finding himself still unable to cope with the increased demand, he established in 1800 a branch works in a disused monastery near Passau, the locality from which was obtained the porcelain clay.

A large proportion of the productions were only very slightly decorated; on the other hand, many were as sumptuously painted as possible, as, for instance, a service made in 1801 for Furst Kurakin, at a cost of 12,000 gulden, and another for Graf Sauran for 6,500 gulden. One of the most distinguished names connected with the Vienna factory is that of Joseph Leithner, who in addition to being a painter, was also the color arcanist of the factory. Among his services may be noted the invention of the well-known reddish-brown color which was for a prolonged period a secret envied by other factories. To him is also attributed the introduction of relief decoration in gold, the process of which, through disuse in the later periods, became temporarily lost, although it has been revived since and is in general use in most of the European factories.

(To be continued.)

M. J. Scudder, Bradford, Pa., has sold his store at 107 Main St. to T. O. Phelps. Mr. Scudder contemplates moving to Jamestown, N. Y.

Thus far no trace has been found of the thief who recently threw a rock through the window in the store of C. A. Scudder, Athens, Ga., and escaped with about \$25 worth of jewelry. The burglary occurred at 6 o'clock in the morning.



Nursery Rhymes

China Body
Enamel Colors

The latest production of the **Royal Doulton** factories. Exquisitely enameled in rich colors.



Sole Agent

W.S. Pitcairn
44 Murray Street
New York

Write for Booklet, "Quaint Bits of Royal Doulton"

NURSERY RHYMES

SERIES No. 1000

-  1. Snap complete.
-  2. Outside of snap.
-  3. Inside of snap.

The E. P. H. Patent NON-PULL-OUT Neck Chain Snap

is a patented snap that insures the wearer against loss of

CHAIN or CHARM
for it positively will not pull out

Made in 10 and 14 Karat Gold and in Gold Filled.

Can be had of the following Wholesale Selling Agents:

- Messrs. W. Green & Co.,
81 Nassau St., New York
- M. Sickles & Sons, Philadelphia
 - E. A. Cowan & Co., Boston
 - E. & J. Swigart, Cincinnati
 - Swartchild & Co., Chicago
 - Nordman Brothers, San Francisco
 - Leonard Krower, New Orleans
 - A. Walker Co., Providence, R. I.
 - Bauman-Massa Jewelry Co., St. Louis
 - H. S. Meiskey Co., Lancaster, Pa.
 - The Edw. Lehman Jewelry Co., Denver, Col.

PRICES.

- 14 Karat—Small, \$7 per doz. net
- Large, \$7.50 per doz. net
- 10 Karat—Small, \$6 per doz. net
- Large, \$6.50 per doz. net
- Gold Filled—Small, \$2 per doz. net
- Large, \$2.25 per doz. net



TRADE MARK  MARK

ESTABLISHED 1850

HAND BAGS

We have a very extensive collection in all desirable leathers

C. F. RUMPP & SONS
FINE LEATHER WARE

Fifth and Cherry Streets
PHILADELPHIA

New York Salesrooms, 683 and 685 Broadway

Correspondence Solicited

JACOT MUSIC BOX CO.
MIRA MUSIC BOXES AND MIRAPHONES
39 UNION SQUARE - NEW YORK

PRACTICAL COURSE IN ADJUSTING
Published Price, \$2.50.
Special Reduced Price, \$1.50, Postpaid.
All Jobbers or Jewelers' Circular Publishing Co.

UNIQUE ART GLASS AND METAL CO.

46 PARK PLACE, NEW YORK

Makers of High Grade

Art Glass Dining Room Fixtures

LAMP SHADES, ELECTRIC
SHADES AND PORTABLES

CALL IN AND SEE OUR BEAUTIFUL LINE OF PRODUCTS AT POPULAR PRICES

Also an elegant line of Rich Crystal Cut Glass at Factory Prices

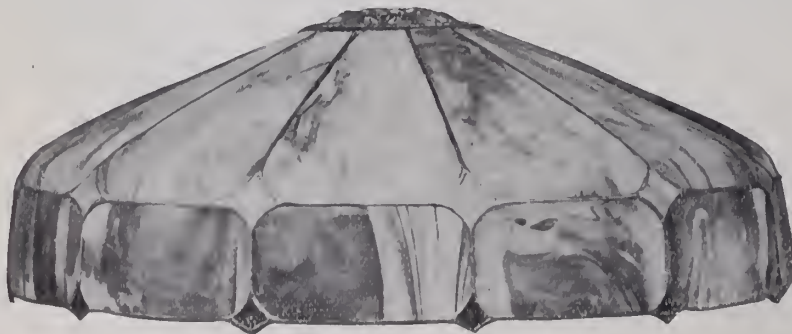

3039 - 16 in. Diameter

BUYERS' INFORMATION BUREAU

Questions as to the makers of certain lines of goods, where to buy certain lines, where certain kinds of work are done, the owners of certain trade-marks and other matters relating to the buying branch of a jewelry business will be cheerfully answered under this department. *All queries are also answered promptly by mail.*

ITHACA, Mich., Feb. 5, 1908.

Editor of THE JEWELERS' CIRCULAR-WEEKLY:
Who makes the Heppelwhite pattern in sterling at ware?

V. C. M.

ANSWER:—Reed & Barton, Taunton, Mass.

AKRON, O., March 3, 1908.

Editor of THE JEWELERS' CIRCULAR-WEEKLY:
Can you tell us what year the firm of Jerome & Darrow were in business, and where?

G. K. F. Co.

ANSWER:—From the year 1824 to 1837, at Bristol, Conn.

NEW YORK, March 17, 1908.

Editor of THE JEWELERS' CIRCULAR-WEEKLY:
Can you inform me of any place in New York where I can procure hard wood shield such as ear heads are mounted upon?

A. K.

ANSWER:—Jno. Murgatroyd, 49 W. 24th St., New York.

FRANKLIN, Pa., Feb. 14, 1908.

Editor of THE JEWELERS' CIRCULAR-WEEKLY:
Who makes the Plato clock?

R. L. K.

ANSWER:—The American Electrical Novelty & Mfg. Co., Spring and Hudson Sts., New York.

OPELIKA, Ala., Feb. 5, 1908.

Editor of THE JEWELERS' CIRCULAR-WEEKLY:
Will you please give me the address of the manufacturers of the Essex watch case?

J. C. C.

ANSWER:—This case was made by the Courvoisier-Wilcox Mfg. Co., which went out of business several years ago and had no successors.

RICHMOND, Va., March 1, 1908.

Editor of THE JEWELERS' CIRCULAR-WEEKLY:
Will you kindly give us the address of the Barbour Silver Co.?

E. B. T. Co.

ANSWER:—International Silver Co., Meriden, Conn., is the successor of this company.

DETROIT, Mich., March 7, 1908.

Editor of THE JEWELERS' CIRCULAR-WEEKLY:
Will you kindly furnish us with the name of the makers of the Georgian and Marlborough patterns in silverware?

J. K. & Co.

ANSWER:—The Georgian is made by the Towle Mfg. Co., Newburyport, Mass.; the Marlborough by the Frank M. Whiting Co., North Attleboro, Mass., and Reed & Barton, Taunton, Mass.

SPRINGFIELD, Ill., Feb. 10, 1908.

Editor of THE JEWELERS' CIRCULAR-WEEKLY:
Kindly inform us if the Boston Clock Co., Boston, Mass., is still in existence.

L. Bros.

ANSWER:—No. The company was succeeded by the Vermont Clock Co., which in

turn was succeeded by the Kilbourne Mfg. Co., 45 Maiden Lane, New York.

MEMPHIS, Tenn., March 20, 1908.

Editor of THE JEWELERS' CIRCULAR-WEEKLY:
Please give me the address of the Brass World.

A. G. H.

ANSWER:—Bridgeport, Conn.

SAN ANTONIO, Tex., Feb. 15, 1908.

Editor of THE JEWELERS' CIRCULAR-WEEKLY:
Who makes the Cyma watch?

W. E. R.

ANSWER:—Adolph Schwob, Switzerland. It is imported by this house and sold through the New York office, 170 Broadway.

ATHENS, Ga., Feb. 12, 1908.

Editor of THE JEWELERS' CIRCULAR-WEEKLY:
Can you give me the name and address of three publications similar to THE JEWELERS' CIRCULAR in the electrical line?

R. B.

ANSWER:—*Electrical World*, 239 W. 39th St., New York; *Electrical Review*, 13 Park Row, New York, and *Electrical Age*, 253 Broadway, New York.

FINDLAY, O., Jan. 30, 1908.

Editor of THE JEWELERS' CIRCULAR-WEEKLY:
Who makes the Mt. Vernon pattern in flat ware?

O. B. M. & Co.

ANSWER:—The Rogers, Lunt & Bowlen Co., Greenfield, Mass.

American Participation Solicited in the World Exposition to Be Held at Rome and Turin.

THE Italian ambassador at Washington, Baron Edmondo Mayor des Planches, furnishes, through the Department of State, the following note in relation to an international exposition to be held at Rome and Turin three years hence in commemoration of the 50th anniversary of the proclamation of the Kingdom of Italy:

Rome and Turin, with the co-operation of all the Italian provinces, are making preparations for a solemn celebration of the 50th anniversary of the proclamation of the Kingdom of Italy.

As a part thereof, the two cities have announced an international exposition which will be held in 1911 under the auspices of His Majesty the King, at Rome in its artistic and historico-archæological part, and at Turin in the part which includes the products of industry and labor in their various manifestations.

The Government of Italy invites the participation of the United States in the International Competition of Industry and Labor at Turin and of Art and History at Rome.

His excellency the Minister of Foreign Affairs lastly suggests that it would undoubtedly be expedient, in order to facilitate the participation, if it be decided to take part, that steps be taken here to appoint a commissioner-general who might, at the proper time, communicate directly with the exposition's committees on organization.

A thief smashed a show window in the store of George Charters, Xenia, O., recently and darted off with a large amount of jewelry. He was arrested shortly afterwards in Dayton as he was entering a pawnshop. When searched 28 gold watches, several gold brooches, rings and diamonds were found in his pockets. He was identified as John Dunbar, a former convict.

TRADE-MARK INFORMATION WANTED.

The following marks have been forwarded to THE CIRCULAR-WEEKLY for identification, but so far, searches of our records and inquiries among manufacturers have failed to disclose the owners or users thereof. The publishers will be greatly obliged to any subscriber who can forward any information whatsoever as to the marks that will lead to the discovery of the manufacturer who has used or is using any of them.

STERLING O 800.

On Silverware.

BRITANNIA ARTISTIC SILVER.

On Toilet Ware.

S. & W.

On Bracelets.

B. & CO.

On Bracelets.

14KT. A.

On Gold Jewelry.

F. M. CO.

On Bracelets.

G. 1/4 F.

On Jewelry Cards.

I. M. C.

On Chains.

F. S. & CO.

On Toilet Ware.

W. H. & CO.

On Bracelets.

EMPIRE ART SILVER.

On Plated Silverware.

EASTERN SILVER CO.

On Hollow Ware.

A. L. BRO.

On Chains.

C. H. & L. CO.

On Gold Pencils.

D. & R.

On Chains.

SOUTHINGTON CO.

On Hollow Ware.

M

On Swivels of Chains.

OHIO MFG. CO.

On Watch Cases.

J. M. P. & CO.

On Leather Fobs.

EUREKA SILVER PLATE CO.

On Silver Plated Goods.

CONTINENTAL WATCH CO.

On Watch Movements.

STERLING B.

On Flat Ware.

L. S. CO.

On Silverware.

GEM SILVER CO.

On Hollow Ware.

J. B. & G. or J. B. & C.

On Chains.

A SHEAR

that will cut any kind of design to perfection. Better have a pair—they are mighty useful.

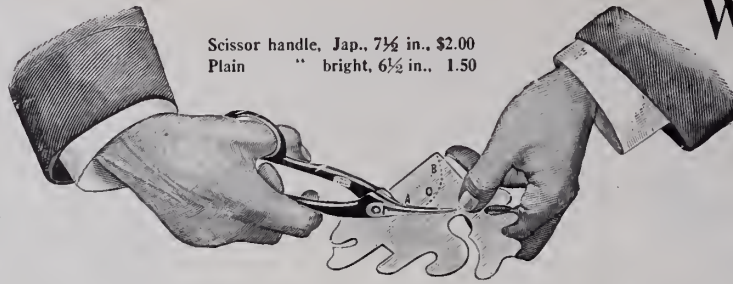

Scissor handle, Jap., 7½ in., \$2.00
Plain " bright, 6½ in., 1.50

William Dixon,

Incorporated

39 John St., New York

Formerly

F. W. GESSWEIN COMPANY

LEES & SANDERS,

DISTANCE IS NO OBJECT. GET IN TOUCH WITH THE ACTUAL SMELTERS

SWEEP SMELTERS, BIRMINGHAM, ENG.

WM. F. RENZIEHAUSEN CO.

'Phone 3759-R.

43-47 Oliver Street, NEWARK, N. J.

Gold and Silver Refiners

PROMPT RETURNS MADE FOR ANY MATERIAL CONTAINING PRECIOUS METALS
DEALERS IN GOLD AND SILVER, AND ROLLERS OF STERLING SILVER

Gold and Silver Anodes a Specialty



WE BUY

Old Gold and Silver Filings, Polishings, Sweeps, Hand Washings, etc. We will make accurate valuations and hold consignment subject to your acceptance. If valuation is not satisfactory, we reship to you at our expense.

WE PAY FOR OLD GOLD:

22 K. 88c. per dwt.	12 K. 48c. per dwt.
20 K. 80c. " "	10 K. 40c. " "
18 K. 72c. " "	8 K. 32c. " "
16 K. 64c. " "	6 K. 24c. " "
14 K. 56c. " "	4 K. 16c. " "

MARKET RATES FOR SILVER AND PLATINUM

Try us and you will Appreciate our Squareness, Promptness and Accuracy.

WE SELL

Gold, Silver and Platinum, various qualities, rolled flat or drawn to wire of any gage.

PRICES OF ALLOYED GOLD:

8 K. 42c. per dwt.	14 K. 66c. per dwt.
10 K. 50c. " "	16 K. 74c. " "
12 K. 58c. " "	18 K. 82c. " "

Gold and Silver Solder, either from formulas furnished, or our own. "T. B. H." Alloy, 25c. per oz. Guinea Gold, 75c. per lb. Shot Copper, 40c. per lb. We will send tables for alloying without charge. They save figuring.

T. B. HAGSTOZ, Ltd., Main Office, 709 Sansom St., Philadelphia, Pa.
SMELTERS, ASSAYERS, REFINERS.

PLATINUM AMERICAN PLATINUM WORKS

NEW YORK OFFICE
41 Cortlandt Street

NEWARK, N. J.

The St. James

Cor. Walnut and 13th Sts., Phila., Pa.

THE IDEAL HOTEL OF THE QUAKER CITY

A spacious fire and burglar proof safe has been provided for the convenience of the trade. Palatial rooms with bath \$2.50 per day and up. Rooms without bath, (running water) \$2.00 and up.

EUGENE G. MILLER, Mgr.

THE WASHBURN

SECURITY Automatic Holder for all sizes of scarf wire. Guaranteed.
MAGIC NUT for ear studs, scarf-pins etc.



EAR WIRES for unpierced ears.

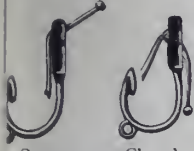

Open. Closed. Open. Closed.

SAFETY CATCH For Brooches, etc. Can be applied to any work where pin tongues are used.
 Descriptive Circular on Application.
Pearl Drilling and Adjusting a specialty.
 Special Order Work and Repairing.
 IRVING WASHBURN, 12-16 John St., N. Y.

CRUCIBLES.

Jewelers' Supplies, Etc.
 Established 1850.
J. & H. BERGE,
 95 John Street,
 NEW YORK.

PATENTS

Obtained on inventions and designs. Trade-marks, prints and labels registered.
R. W. BISHOP,
 ATTORNEY-AT-LAW,
 108 G Street N. W., Washington, D. C.

Above Cut Shows Our
METAL SPINNING LATHE
 We manufacture these lathes in sizes from 12-inch to 44-inch Swing, and can equip sizes 18-inch and larger with our Chucks for oval work.
 Write for Catalogue **P. PRYIBIL,** 512-524 W. 41st St., New York.

L. LELONG & BRO.
 Gold and Silver Refiners, Assayers and Sweep Smelters
 S. W. Cor. Halsey and Marshall Sts., NEWARK, N. J.
 Prompt attention given to Gold and Silver Bullion.
SMELTING FOR THE TRADE.

JOHN AUSTIN & SON
 Assayers, Refiners and Smelters
 74 & 76 Clifford Street PROVIDENCE, R. I.
We Do Our Own Smelting.

UNITED STATES SMELTING AND REFINING WORKS
L. & M. WOLLSTEIN
 16 JOHN STREET, NEW YORK
SWEEP SMELTERS AND ASSAYERS
 Dealers in Gold and Silver Assay Office Bars. HIGHEST and MOST PROMPT RETURNS made for Sweeps and all kinds of Waste containing precious Metals.
HIGHEST PRICES PAID FOR OLD GOLD AND SILVER
 Manufacturers of STERLING SILVER. Importers of PLATINUM. Ore and Bullion Assays a Specialty.

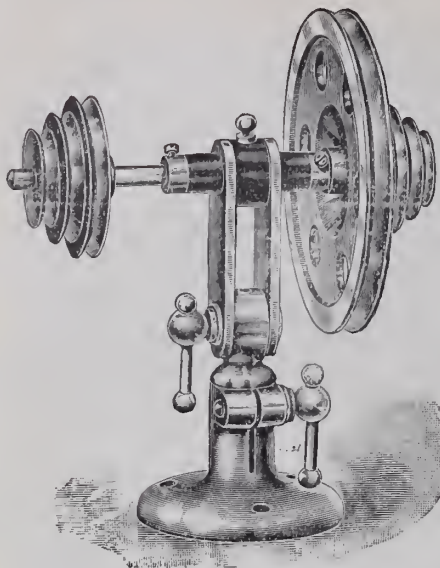

A New Patent Speed Wheel Countershaft

made by G. Boley, all polished and nickel plated, being made with hard bronze bearings which insure perfectly true running, with attachment to hold all wheels for grinding or polishing.

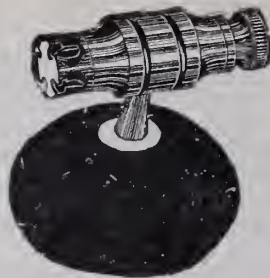

Robbins Upright Roller Remover

With Improved Revolving Disk and Plunger

Flat bottom, which sets firmly on the bench. You cannot break pivots with this tool, as it is very easily adjusted for any size from jewel series to the largest size. Single or double roller. Nickel-plated. Price, \$2.25.

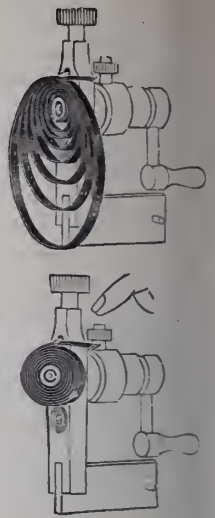
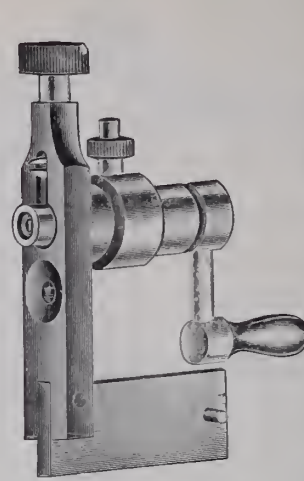

Robbins' Latest Improved Patent Mainspring Winder

Does away with changing of barrels, which alone is a time saver.

Nickel plated, price \$2.00. Directions with each tool.

ASK YOUR
JOBBER
FOR SAME

SOLE AGENTS:

77 John Street,
New York City

HENRY ZIMMERN & CO., Inc.

Exclusive Wholesale
Distributors for
U. S. and Canada.



CHAS. E. MANOR

America's Premier Jewelry Auctioneer

**== ACTION ==
Beats Utterance!**

A ton of talk isn't worth an ounce of DO!
Don't argue, hesitate, delay or quibble!
On the great clock of time there is but one word

NOW

BIG THINGS ARE WORTH DOING

If you want a big and successful Auction Sale

DO IT NOW

I have a higher number of such sales to my CREDIT than any other Auctioneer.

I not only sell the goods but make you A PROFIT. PROCRASTINATION is the thief of time. You cannot afford to be robbed by any such thief as Procrastination. If you are in need of money, my advice is, have a MANOR AUCTION; they are always guaranteed successful in every way. ADDRESS

CHAS. E. MANOR,

1016 MAIN STREET, KANSAS CITY, MO.
Long Distance Phone, 1705. I employ an able Corps of Assistants.

THE

JEWELERS' CIRCULAR

WITH WHICH ARE CONSOLIDATED

THE HOROLOGICAL REVIEW,

THE JEWELERS' WEEKLY,

THE JEWELERS REVIEW

Copyright 1908 by
The Jewelers' Circular
Publishing Company.

11 John St., Corner Broadway, New York.

Entered as second-class matter at the New York, N. Y., Post Office.

40th Year

WEDNESDAY, APRIL 1, 1908.

Vol. LVI., No. 9.



Massive Punch Bowl of Silver Service for the United States Battleship "Montana."

(See Text on Page 43.)

ALVIN SILVER

"ORANGE BLOSSOM"

ALVIN

MFG.

CO.



Butter Knife

Sterling
Silver

The true test of a design in table silver is the effect produced when the table is arranged for formal hospitality.

Pieces of the Orange Blossom design, shown above, make a most attractive group.

This design is made in over one hundred different articles, and is especially suited to wedding gifts.

It is made in sterling silver, stamped with the above trade-mark, and can be obtained from any jeweler, in sets or single pieces, to meet the requirements of complete service.

"BRIDAL ROSE"

ALVIN

MFG.

CO.



Cold Meat Fork

Sterling
Silver

The true test of a design in table silver is the effect produced when the table is arranged for formal hospitality.

Pieces of the Bridal Rose design, shown above, make a most attractive group.

This design is made in over one hundred different articles, and is especially suited to wedding gifts.

It is made in sterling silver, stamped with the above trade-mark, and can be obtained from any jeweler, in sets or single pieces, to meet the requirements of complete service.

The two most appropriate patterns of Sterling Silver Flat Ware for wedding anniversaries. These patterns are being advertised in the leading magazines to stimulate trade, and to reach the retail jewelers.

These magazines will be read in millions of homes all over the United States.

Be prepared to meet the demand. Complete your stock with fancy pieces and cutlery.

ALVIN MFG. CO., Silversmiths, NEW YORK



Tahys

Permanent Case Senior Style

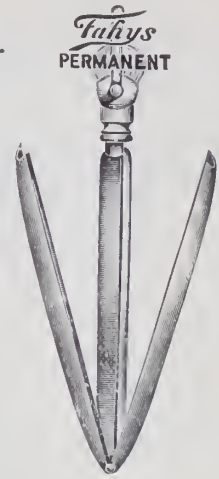

The new thin model is the thinnest case made for an American movement, with the added feature of being dust-proof, as the movement shuts down into a shell or cup into which no dust can possibly penetrate.

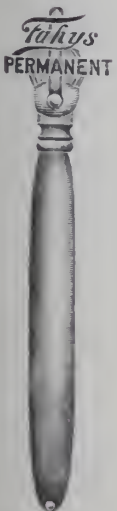
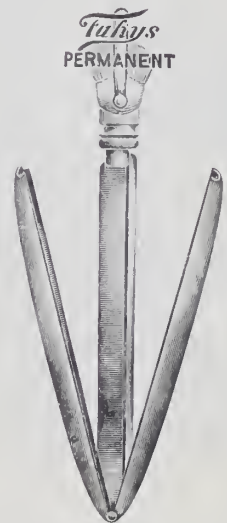

All of our cases are made with our patent one-piece pendant, which eliminates all solder; this patent is controlled by us exclusively.

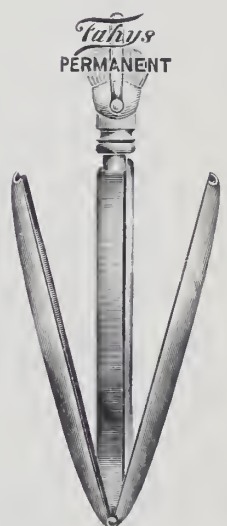

JOSEPH FAHYS & CO.

NEW YORK

BOSTON

CHICAGO

SAN FRANCISCO

A GENERAL FAVORITE



A general favorite is one whom everybody likes.

Our diamonds are general favorites with those who have seen them.

First, because of the perfection of their cutting, assuring greatest brilliancy, and,

Second, because, we being cutters, there are not two or three profits tacked on to the actual worth of the stones.

J. R. WOOD & SONS

DIAMOND CUTTERS

Importers of Emeralds, Rubies and Sapphires

2 Maiden Lane, Corner of 170 Broadway . . . NEW YORK

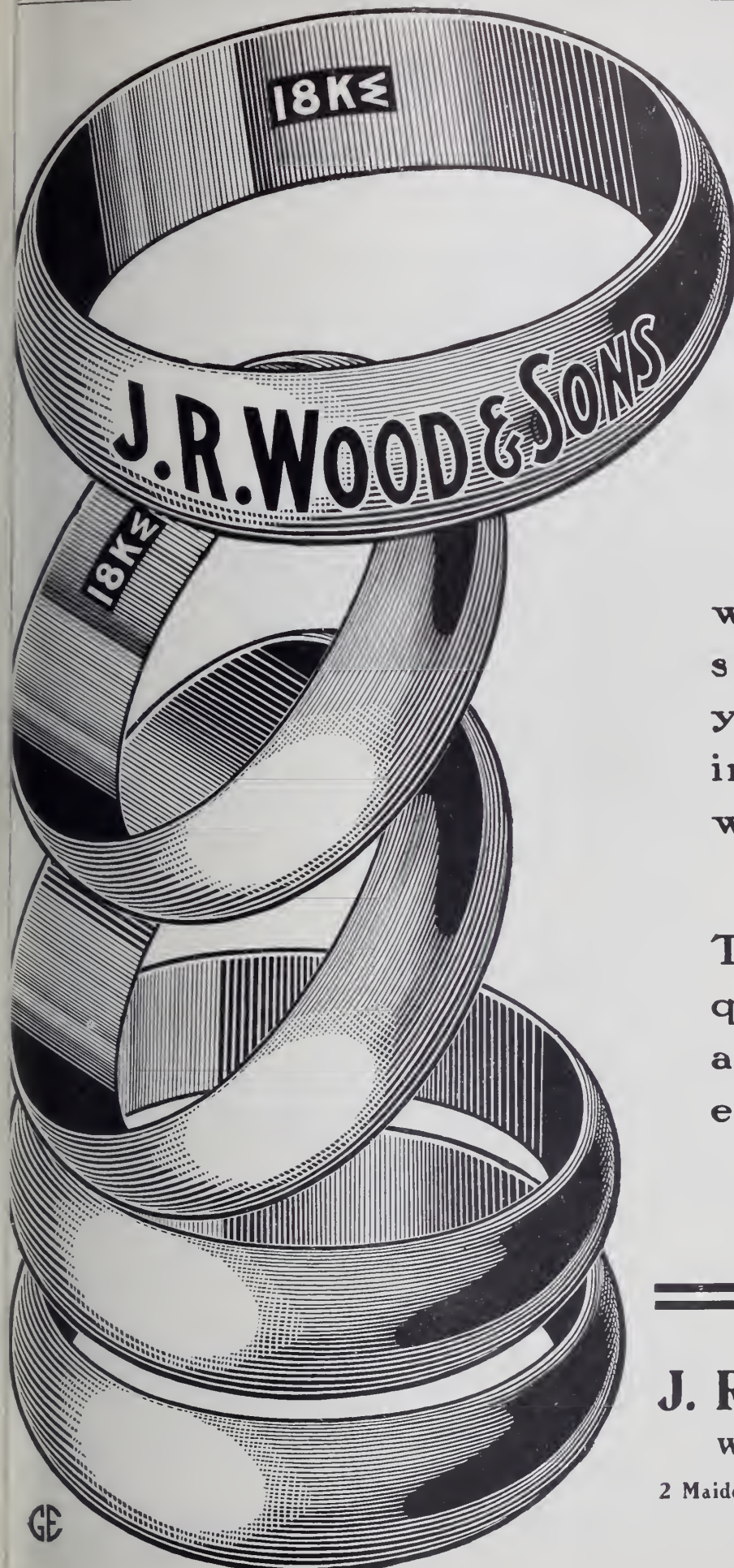

At The Top of the Heap

where they have stayed for **57** years; where we intend them always to remain.

The standard for quality, for finish, and for general excellence.

J. R. WOOD & SONS

WEDDING RING MAKERS

2 Maiden Lane Corner of 170 Broadway

NEW YORK



Did you ever know a good thing that was not imitated?

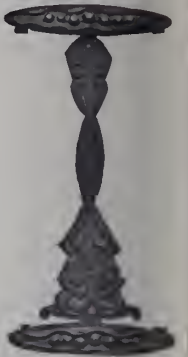

“Fashion”

Collar Pins

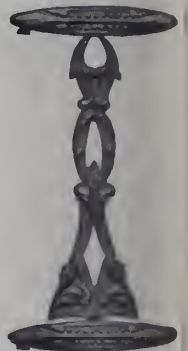

PATENTS PENDING

FULLY COVERED, ALL RIGHTS RESERVED

An Absolutely New Article which Sells at Sight. Try It.

MANUFACTURED IN ROLLED PLATE BY

Wolcott Manufacturing Co.

71 Peck St., Providence, R. I.

New York Office, 14 Maiden Lane

MANUFACTURED IN 10KT. SOLID GOLD BY

JOHN T. MAURAN MFG. CO., Providence, R. I.



Flat Belcher ring as received with claws badly worn.



How the same ring looks when stone is reset without new claws. Stone is not secure and point is below inside of ring.

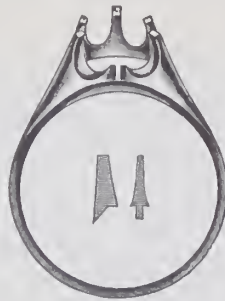

How we splice settings and solder in new claws; seams do not show and rings are as perfect as when originally made.

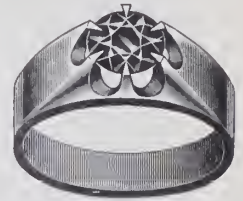

How ring looks with new claws and stone securely reset. Entire ring is finished like new.

When we tell you that we have received as many as 75 diamond rings in one day for new claws and settings, you will not think us extravagant for using a full page in THE JEWELERS' CIRCULAR to exploit this feature of our business, but will wonder if you are getting your share of claw work.

99 out of every 100 owners of diamond rings willingly pay \$1.50 to \$5 for new claws or settings on their rings, but would not buy new mountings for \$5 to \$25.

It is worth while to familiarize yourself and your employees with this work, as it is one of the important little things that helps to make your business profitable.

WENDELL & COMPANY

The firm that did much to change the repair end of the Retail Jewelry Business from a source of worry and dissatisfaction to one of pleasure and profit.

103-105 William Street
New York

TWO WONDERFUL SHOPS

57 Washington Street
Chicago

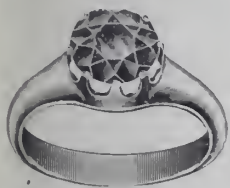

Flat Belcher ring as received with worn claws. Stone cannot be reset, as it would be too low to look well and the point would come below the inner circle of ring.
(See cut No. 2 of flat Belcher.)

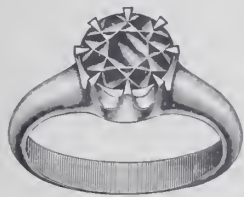

How same ring looks with new claws and stone securely reset. Entire ring is finished like new.



Oval Belcher ring as received with claws badly worn. Stone cannot be reset, as it would be too low to look well and the point would come below the inner circle of ring.
(See cut No. 2 of flat Belcher.)

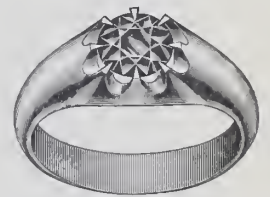

How same ring looks with new claws and stone securely reset. Entire ring is finished like new.

THE PRICES QUOTED ABOVE FOR NEW CLAWS AND SETTINGS ARE SUBJECT TO OUR CATALOGUE DISCOUNT.

WE CAN PUT NEW CLAWS AND SETTINGS ON MOUNTINGS TAKEN IN TRADE AND REFINISH THEM SO THEY WILL BE AS GOOD AS NEW.

WE RETIP CLAWS AND MAKE NEW SETTINGS FOR CLUSTER MOUNTINGS SO THEY ARE AS GOOD AS WHEN ORIGINALLY MADE, AT PRICES THAT MAKE IT ADVANTAGEOUS FOR THE OWNERS TO HAVE THIS WORK DONE.

Carrying no diamonds in stock, entering and tagging each piece of diamond jewelry as received, then giving to each workman but one ring at a time, which is returned before he receives another, prevent any possibility of diamonds being exchanged while in our possession.

The Big Dipper

Will Dip Up Profits For You



THE
BEST IN EVERY
GRADE

CHICAGO
701 Heyworth Bldg.

Ask your Jobber

NEW YORK
Maiden Lane

STARWATCH CASE CO.

LUDINGTON, MICHIGAN

COPYRIGHTED BY T. F. KENNEDY

ONE AND ONLY ONE WADSWORTH 20-YEAR CASE

REMEMBER

THAT we make ONE LINE—and only one line—of 20-YEAR CASES.

THAT this one line is THE BEST on the market for the price.

THAT QUALITY AND STYLE are consistently maintained.

THAT the policy of ADVANCE and improvement has suffered no abatement.

THAT new and attractive DESIGNS continue to be added as heretofore.

THAT safety lies in buying the WADSWORTH 20-YEAR CASE.

A WORD to the wise is sufficient.

The WADSWORTH
WATCH CASE
COMPANY

NEW YORK
49 Maiden Lane
CHICAGO
Columbus Building
SAN FRANCISCO
717 Market Street

Factory: Dayton, Ky.

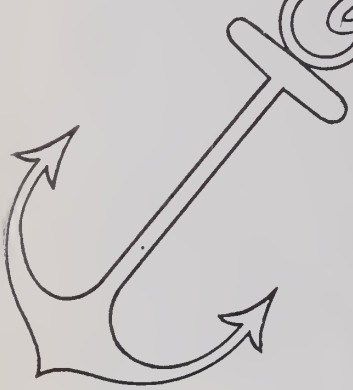

31



32



33



34



35



36



37

12 SIZE
SOLID
GOLD
Dueber Cases
 WHICH ARE SURE
 TO PLEASE.

A Few Words About Mainsprings



Spectacle and Eyeglass Strap Plier No. 105

Price, each, \$1.25

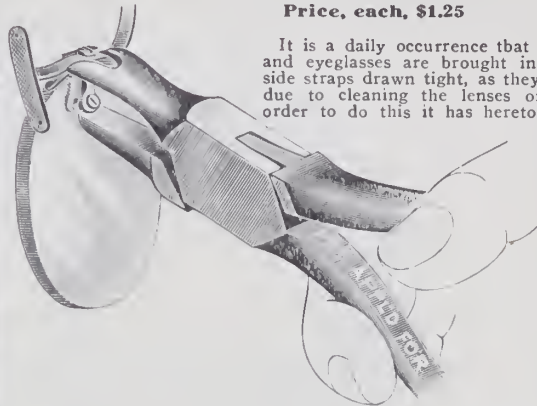

It is a daily occurrence that frameless spectacles and eyeglasses are brought in to have the small side straps drawn tight, as they have become loose, due to cleaning the lenses or other causes. In order to do this it has heretofore been necessary to remove the lenses from the mountings, and as all know, this very often results in breaking or chipping the lenses.

By the means of this plier this can be avoided and the work quickly done.

All that is required is to loosen the screw two or three turns, clamp the frame as shown in the illustration, and bend the straps to the lenses. Retighten the screw, and the work is done.

DO NOT NEGLECT to loosen the screw, as otherwise a good job cannot be done, and the lenses are likely to be broken.

Made of best quality Swedish steel, nickel-plated.

There is no article of material used by the watchmaker or the watch repairer about which, if he be a careful and thorough workman, he feels more solicitous than the *Mainspring*. Next to the fragile watch glass, the mainspring is more frequently replaced than any other article used in watch repairing. While the percentage of breakage is high in all watch springs, it jumps into appalling proportions when they are of an inferior quality, unless their temper is so low as to make them almost useless, and certainly of little value in watches that are to serve the purpose of timekeepers. When we offer you the *Ulysse Sandos Robert* spring, we feel confident that you are getting the best that skillful hands and lifelong experience can produce.

Made for all American Watches. Per dozen, \$1.25

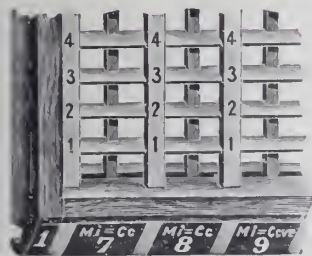

Top View, Showing Skeleton Frame of Drawer. Accumulation of dust and chips is impossible.

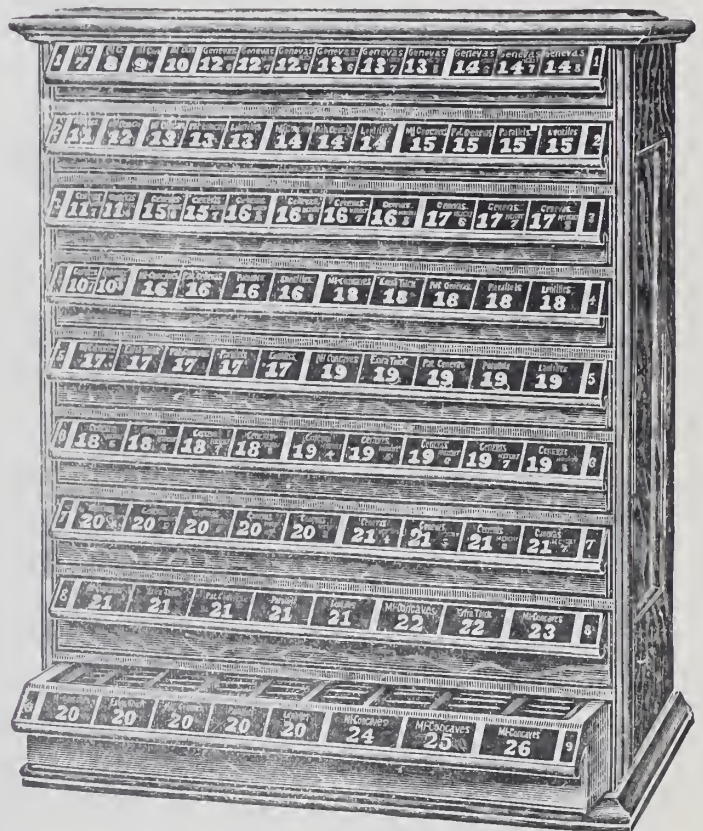

Echarco Watch Glass Cabinet No. 15 (Patented)

Price, each, \$16.00

This cabinet has many new features not found in any other. Novelty and usefulness are the chief arguments in its favor.

CONSTRUCTION AND MATERIAL.—The cases are made of oak, finely finished and of attractive appearance. Sides are paneled. Partitions of basswood and put together in best manner possible.

PARTITIONS are skeleton, preventing accumulation of dust, chips, etc.

BOTTOMS of cabinets are hollow to receive chips, dust, etc.

ARRANGEMENT FOR GLASSES.—The 9 drawers contain 1,547 spaces to hold glasses in upright position.

Labeling of drawers as shown in cut is on the pulls of the drawers and done in gold bronze on black background.

DIMENSIONS.—24 inches wide, 29 1/2 inches high, 12 inches deep; weight, 45 lbs.; with packing case, 75 lbs.

The construction of drawers, the arrangement of partitions to economize space and weight, and the novel method of showing contents on drawer-pulls are all prominent characteristics and extremely well thought of.

FOR SALE BY ALL JOBBERS IN THE UNITED STATES AND CANADA

HAMMEL, RIGLANDER & CO. 47-49 Maiden Lane
New York

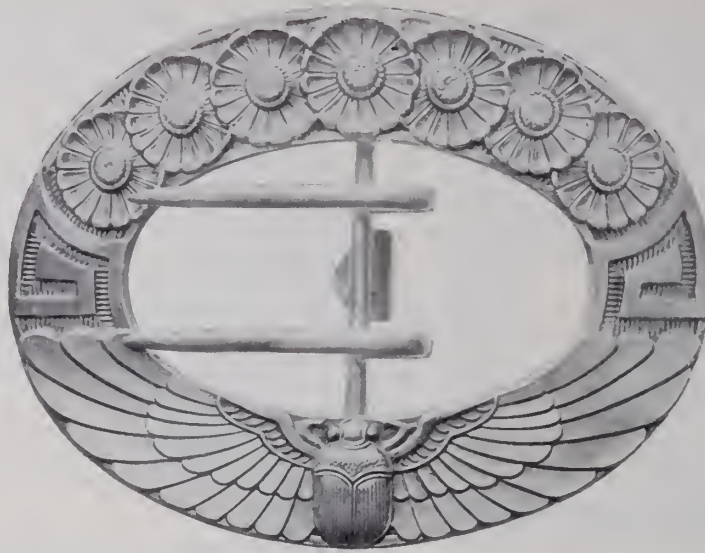

OUR new Buckle and Belt Pin Catalog is now ready and will be sent out in a few days. If you do not receive one, we will gladly send you a copy on request.

We met with such great success with our Buckles that we were encouraged to add from time to time a great many new pieces until we now have as complete and comprehensive a line as any jeweler could desire.

The accompanying illustration suggests one part of the line that we have developed in which is embodied the Egyptian character of ornament.

These Buckles are of heavy weight and no expense has been spared to give them the finest finish possible.

We take this occasion to thank the trade for the support they have given this part of our line in the past and would ask for a continuance of their favors.

R. BLACKINTON & CO.

Established 1861 TRADE  MARK SILVERSMITHS
 FACTORY, NORTH ATTLEBORO, MASS.
 3 Maiden Lane, New York

WHITING MFG. COMPANY



Sterling Silver Vases

ESPECIALLY appropriate for gift purposes at this season of the year in connection with Easter and Spring Weddings.

A timely suggestion will be found by the Retail Jeweler in the attractive series here illustrated, which, though effectively decorative in design, is markedly moderate in price.



No. 893
6½ inches

No. 1893A
8½ inches

No. 2893
10½ inches

No. 3893A
12½ inches

No. 4893
14½ inches

The Whiting Company's line of vases is unusually comprehensive, ranging from examples such as are here shown to special pieces of the most elaborate and ornate character.

BROADWAY AND NINETEENTH STREET

San Francisco, Cal.,
717 Market St.

NEW YORK



A Refined Afternoon Tea-Service

is incomplete without the Sternau Tray. It has become a recognized addition and grown to be almost a necessity in many homes for the chafing dish outfit and when serving chocolate.

The Sternau Tray is most appropriate for the display of artistic pieces of silver or cut glass.

Catalogue No. 21-Z, containing our full line of specialties, especially adapted to the jewelry trade, sent on request.

S. STERNAU & COMPANY,

Makers of *STERNAUWARE*

New York Showrooms
BROADWAY, COR. PARK PLACE
Opposite Post-office

Consisting of
Coffee-machines, Fancy Teakettles, Chafing-dishes
and their Accessories, Smoking Sets, Alcohol-
stoves, Coffee and Tea Pots, Candlesticks, Trays,
Baking-dishes, etc.

Office and Factory
195 PLYMOUTH STREET
BROOKLYN, N. Y.

NEW YORK, 9 Maiden Lane
CHICAGO, 103 State Street

BATES & BACON ATTLEBORO MASSACHUSETTS

THE LEADING HOUSE FOR HIGH-GRADE GOLD-FILLED CHAINS,
LOCKETS AND BRACELETS

Something New for Easter!

THE "WINNA" BRACELETS
Strongest secret joint and catch on the market

SOME OF OUR NEW DESIGNS
ORDER OF YOUR JOBBER



F 450
E 22



L.1261



L.1262



PAT. B 662
SIZE 7 1/2 IN. WIDTH 3/4 IN.



PAT. B. 660
SIZE 7 IN. WIDTH 5/16 IN.

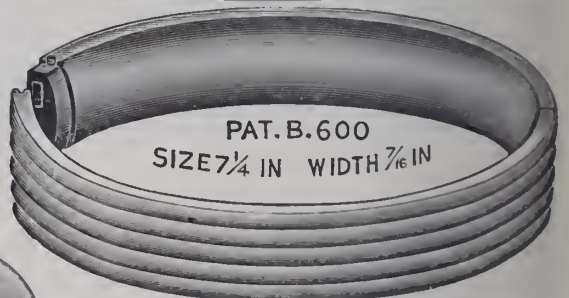

PAT. B. 600
SIZE 7 1/4 IN WIDTH 7/16 IN



PAT. B. 661



WE show herewith a new style bag—an exceptionally strong, stylish, snappy article.

Our new Spring line is complete—covering the entire range of bags—all shapes, all the different styles of mesh—the largest assortment of frames ever shown. Every piece stamped. W. & D. an absolute guarantee of satisfaction.

Your Jobber has them.

WHITING & DAVIS
PLAINVILLE (Norfolk Co.), MASS.

New York Office, 7 Maiden Lane

COMPLETE YOUR STOCK WITH RIGHT GOODS

GOLD RINGS

Gold Scarf Pins

Gold Brooches

A Handsome Line of Seamless Wire GOLD FILLED RINGS

All ready for prompt delivery to the Jobber

OSTBY & BARTON CO.
PROVIDENCE, RHODE ISLAND

New York Office
9-13 MAIDEN LANE

Chicago Office
103 STATE STREET

The Best Selling "Thread" Pattern in the Trade



The SMITH "PILGRIM"

There never has been a more artistic and lasting design than the Smith "Pilgrim." It is characterized by simple elegance, refinement and dignity of design, and grateful absence of over-ornamentation. The Smith "Pilgrim" pattern will remain permanently in demand. Include "Pilgrim" in your stock. It is without question the best selling "thread" pattern in the trade to-day. Made in all the fancy pieces.

FRANK W. SMITH CO. MANUFACTURERS OF STERLING SILVERWARE Gardner, Mass.



TRADE MARK



2/3 SIZE



The Original Carmen Adjustable Bracelet

With 20 years' experience and the best factory equipment that can be procured, we are able to produce

THE BEST IN THE WORLD FOR THE MONEY

The stamp, "The D. F. B. Co.," is a guarantee of quality and up-to-date designs. Ladies' and Gentlemen's Chains, Fobs, Lorgnettes, La Vallieres, Hat Pins, Chatelaine Pins and Bracelets.

THE D. F. BRIGGS COMPANY

ATTLEBORO, MASS.

NEW YORK OFFICE
180 Broadway

CHICAGO OFFICE
Heyworth Bldg.

ST. LOUIS OFFICE
Mermod & Jaccard Bldg.

LONDON OFFICE
118-122 Holborn E. C.



EASTER is the time of awakening and it brings with it a revival of the jewelry business. Many articles are called for, appropriate to the time and season, and the jeweler should be properly supplied. We have full lines of suitable goods: Crosses, Cuff Pins, Veil Pins, Locketts and Chains, also Fobs and Scarfpins, etc.; in fact, everything that may be desired in this line. They are all "Sellers," and we should be pleased to send memo. package upon request.

"Sellers
of
Sellers"

HENRY FREUND & BRO.

71 Nassau St., NEW YORK

Diamonds
Watches
Jewelry

Our Trade-Mark  "The Rose," stands for quality and excellence

壽

"Kotobuki"

壽

(Pronounced Ko-to-bū-ki)

THE JAPANESE WORD FOR LONG LIFE

The Popular Craze in

== SCARF PINS ==

Price in 14 Kt.
\$3.00

MANUFACTURED IN 14 KT. GOLD BY

Price in 14 Kt.
\$3.00

VAN DUSEN & STOKES CO.

MAKERS OF ORIENTAL JEWELRY

IMPORTERS OF CORAL AND SEMI-PRECIOUS STONES

1123 CHESTNUT STREET = = = = = PHILADELPHIA

AARON COEN, Pres.

H. J. SEILER, Vice-Pres.

RALPH WAKEFIELD, Sec'y.

GEORGE B. ADAMS, Treas.

WAKEFIELD & SEILER CO., Inc.

Manufacturers of Fine Jewelry



No. 2001.
Design and Style, Patent applied for.

HA, HA!

 THE NEW HOUSE
WITH NEW IDEAS

SOMETHING NEW IN GRAPE JEWELRY

The Grape Locket

We are showing a very exclusive line of 10K. jewelry made and finished like the 14K. and 18K. fine jewelry now on the market. We make a specialty of Locketts and seamless tube-jointed Bracelets in flat, square, oval and round, and we are also showing a big line of **GRAPE JEWELRY.**

We supply the manufacturing trade with gold and silver tubing used for Bracelets, and joint wire, etc. **WE SELL TO JOBBERS ONLY.**

PHONE 892-L **109 Oliver Street, NEWARK, N.J.**

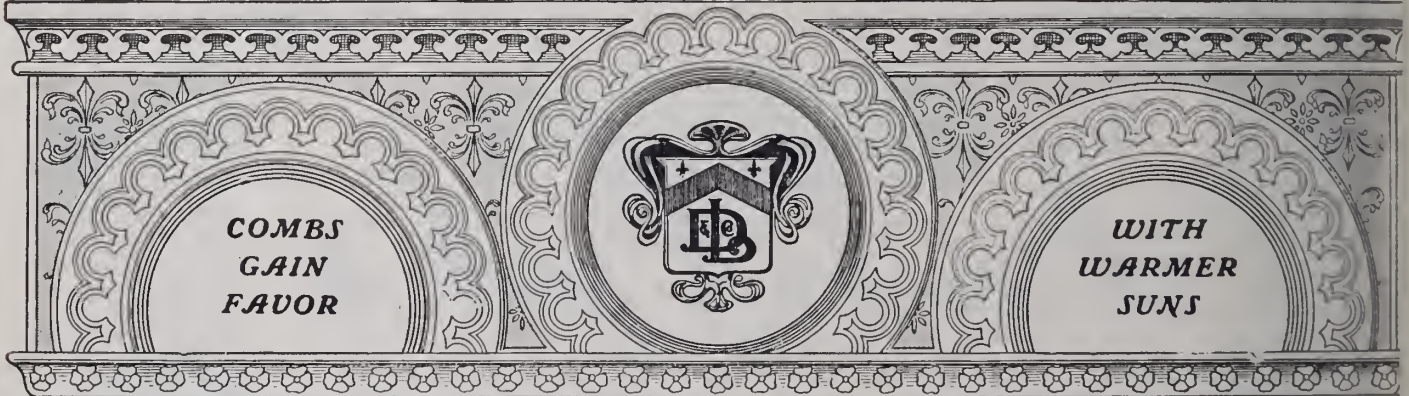

THE TENDENCY to discard the hat when warm weather comes, adds to the importance of the coiffure so that Combs receive emphasis. The very attractive showings of Combs here include Oriental and Egyptian designs, Shell Cameos and effects in Amethyst and Topaz. These goods are so priced that the dealer can sell them from \$3.00 to \$7.50 and realize a good profit.

D. Lisner & Co. *Creating Importers of* **Jewelry Novelties**
One-Forty Fifth Avenue, cor. 19th St., NEW YORK

IN OLIVE POTTERY WITH SILVER ORNAMENTATION

NOTE: ACTUAL ARTICLES
ARE TWICE SIZE OF
ILLUSTRATIONS IN EACH
DIMENSION



"OLIVIA" WARE
NO. 377, TEA (LARGE)
NO. 377, SUGAR (LARGE)
NO. 377, CREAM (LARGE)
NO. 378, TEA (MED.)
NO. 379, TEA (SMALL)
NO. 379, SUGAR (SMALL)
NO. 379, CREAM (SMALL)

IN BROWN POTTERY WITH GILT LETTERS, TRIMS AND BANDS

NOTE: ACTUAL ARTICLES
ARE TWICE SIZE OF
ILLUSTRATIONS IN EACH
DIMENSION



NO. 497
"POLLY" TEA SET

THE J. W. PRATT CO.

Printers

The correct method of preparing half-tone engravings to secure the best results when printed is the most important part of the production of a good catalogue.

On the other side of this sheet we show six silhouetted half-tones, and invite your attention to the perfection of detail brought out in the engraving and printing.

Better let us talk it over with you next time.

THE J. W. PRATT CO.

Engravers and
Printers

52 DUANE STREET, NEW YORK

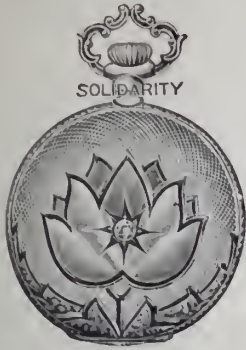

MARGUERITE

MR. RETAILER:

That department in our factory called: "CREATION CORNER" is working overtime.

We simply won't stop creating.

It is just as natural for us to create SNAPPY GOLD WATCH CASES, as it is for a "live wire" to spit sparks.

Some of our prettiest creations will blossom in April and any Jobber will gladly send you a few.



MARGUERITE

Solidarity Watch Case Company

Established 1885

54 Maiden Lane, New York

General Selling Agents:

JOHN W. SHERWOOD

::

::

FRANK E. HARMER

SOLD DIRECT TO THE RETAIL TRADE ONLY

FEATURES OF OUR LINE

The UNIQUE, ARTISTIC and UNUSUAL, together with BEST WORKMANSHIP, SUPERIOR QUALITY and PERFECTION IN FINISH

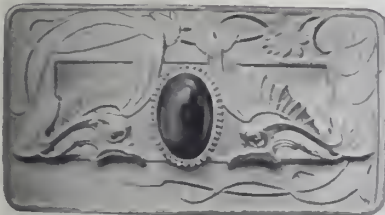

296

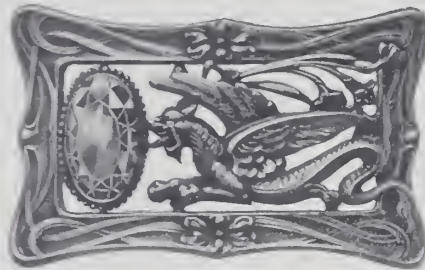

624

SASH BROOCHES

in gold-filled, finished in rose or dark green (antique).

Sash Brooches

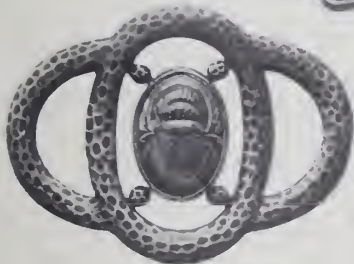

237



316

We use finest imitation stones and can furnish any stone or color required.

We Manufacture in GOLD-FILLED and STERLING SILVER

BROOCHES, HAT PINS, COMBS, HANDY PINS, WAIST PIN SETS, BARRETTES, SCARF PINS, VEIL PINS, LINKS, BUCKLES, SASH BROOCHES, BRACELETS and NECKLACES.

C. RAY RANDALL & CO., North Attleboro, Mass.

NEW YORK OFFICE, No. 7 Maiden Lane

SAN FRANCISCO OFFICE, Henry M. Abrams Co., No. 717 Market Street

Address all orders and communications to Factory, North Attleboro, Mass.

Good Sellers at Easter Time



Here's another sample dozen

SIMMONS ARMILLAS

affording further evidence of the variety and attractiveness of the Armilla patterns.

Beyond dispute, Simmons Armilla is the best selling joint and catch bracelet to-day and should be well represented in your Easter display along with *Simmons Chains* and *Simmons Fobs*—all good Easter sellers.

R. F. SIMMONS COMPANY, Main Office and Works, ATTLEBORO, MASS.

New York Salesrooms:
9-13 Maiden Lane.

Chicago Salesrooms:
42 Madison St.,
(Heyworth Bldg.)

Do You Want More Business?

Hundreds of Retail Jewelers have built up a large business from a very modest start **by buying the M. J. Averbeck lines exclusively.**

This photograph and letter were unsolicited. We can and will show you others.

PHOTO. OF A. W. BIBER'S STORE, SPARTANBURG, S. C.

The successful jeweler buys the line that brings him the most business.

The M. J. Averbeck line has made this house a great success.

It inspires confidence and enthusiasm in the Retail Jeweler.

This M. J. Averbeck line of Sellers will bring you more business. Your success is sure!



A. W. BIBER

Jeweler

Spartanburg, S. C.

190

gentling to...
 M. J. Averbeck
 10 & 12 Maiden Lane, New York

We mailed you our booklet of **Summer Sellers No. 112.** You can't go wrong. Order a **GOOD SUPPLY OF ANYTHING AND EVERYTHING.** Replenish your stock now.

M. J. AVERBECK, Manufacturer and Importer
 10 & 12 Maiden Lane, New York

N.B.—Every Jeweler should know the advantage in buying all his Jewelry, Finger Rings and Novelties from M. J. Averbeck

SUITABLE AND SALABLE GOODS FOR EASTER

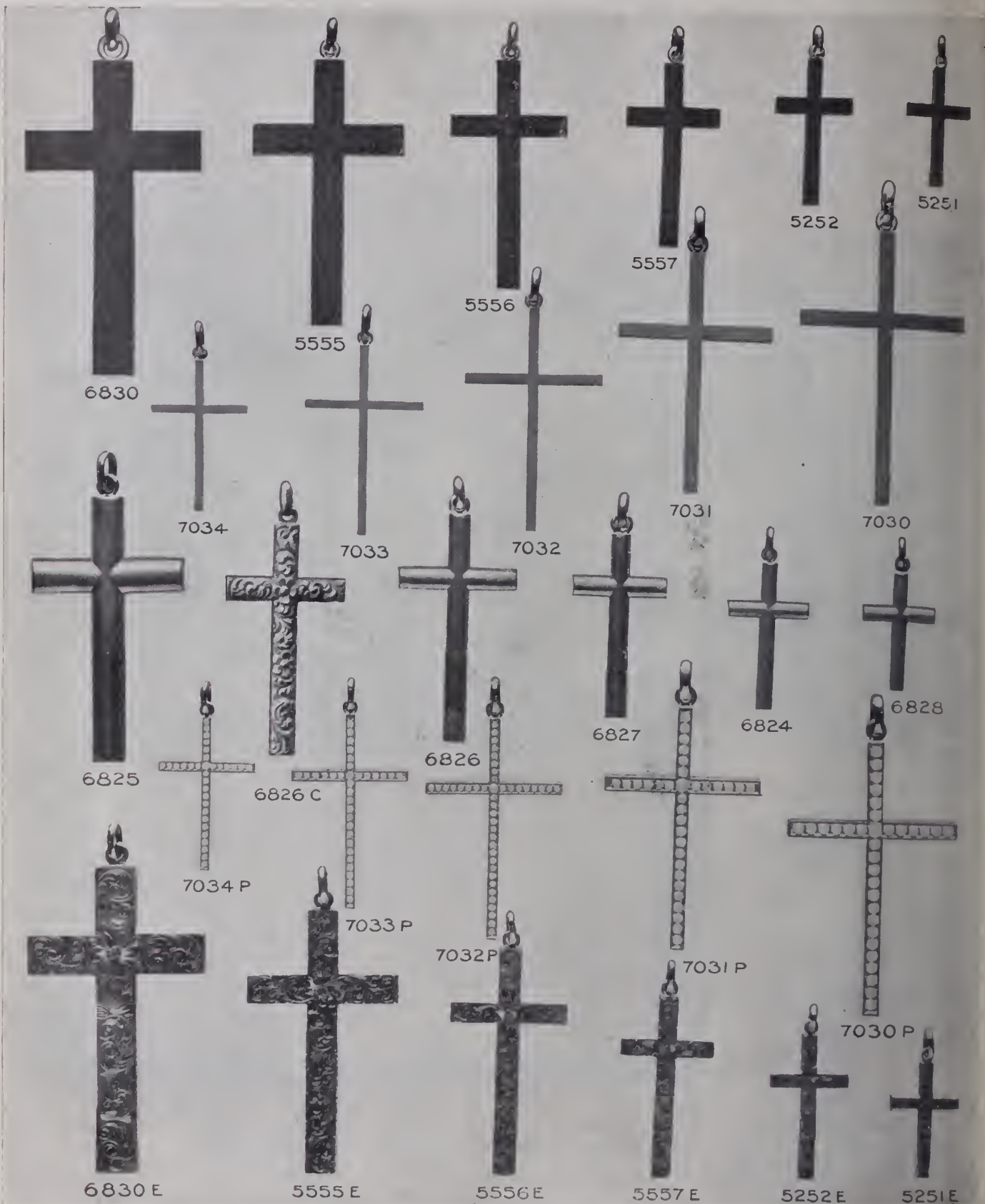

T. W. ADAMS & COMPANY

11 JOHN STREET
NEW YORK

Factory
83 UNION STREET
NEWARK, N. J.

TRADE **A 14 K** MARK

Manufacturers of 14K. Exclusively
ILLUSTRATIONS SHOWING FULL LINE FURNISHED UPON APPLICATION

Chicago Office
103 STATE STREET

The KREMENTZ MATCH BOX

made expressly for paper matches, in 14-Kt. Gold and Sterling Silver, with the following finishes:
Roman, polished, engraved, engine turned and the Kremenz gun metal finish.

Open



Side View
Closed



Order No.
in 14-Kt. Gold
2117

Front View
Closed



Order No.
in
Sterling
Silver
2043

The side and front views show its compactness. It opens and closes easily and fits the vest pocket, taking very little space.

KREMENTZ & CO.

Manufacturers of

Fine Gold and Enamel Diamond Jewelry in 14-Kt. Only

MADE EXCLUSIVELY FOR FINE RETAIL JEWELRY TRADE

BRANCH
San Francisco Office
722 Shreve Bldg.

Factory and Main Office
NEWARK, N. J.

BRANCH
New York Office
1 Maiden Lane

FOBS: HISTORIC, ANTIQUE AND ROMANTIC

TRADE



MARK

A GOOD FOB is more than a Fob. It embodies some special idea, some relation to the past, some romantic conception, some strong human appeal. Such Fobs are prized for more than the stones and the gold. Durand Fobs are examples.

PRICES: \$10.00 to \$220.00

TRADE



MARK

DURAND & CO.

49-51 FRANKLIN STREET
NEWARK, N. J.



OSMUN-PARKER MFG. CO.

MAKERS OF

Fine Pearl and Diamond Goods

338 Mulberry Street
NEWARK, N. J.

ENOS RICHARDSON & Co.

MANUFACTURERS OF

14-K GOLD JEWELRY

TRADE MARK.



- HANDY PINS
- SAFETY PINS
- BROOCHES
- FLAT LINKS
- DUMB-BELL LINKS
- FOBS
- TIE CLASPS
- VEIL PINS
- HAT PINS
- SCARF PINS
- BARRETTES
- BELT PINS

10-K AND 14-K NECK CHAINS AND GUARD CHAINS

PLAIN AND JEWELLED LORGNETTE CHAINS

23 MAIDEN LANE, NEW YORK



The R. S. Cigar Cutter

In Sterling Silver, Plain and Engraved; and 14 k. Gold, Plain and Engraved, also Set with Diamonds.

A Novelty

Unlike all other cigar cutters, this one lies flat in the pocket—does not get out of order.

A Good Article



We Push It

Our advertising makes the customer want it; his friend sees it and he wants it. An endless chain of customers.

A Good Seller

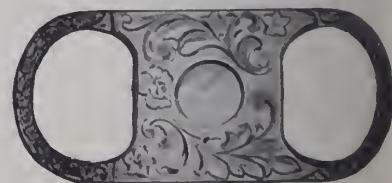

Trade supplied by

Enos Richardson & Co
23 Maiden Lane, New York.

G. R. HOWE
W. T. CARTER
W. T. GOUGH

ESTABLISHED 1841 BY A. CARTER

F. R. HORTON
F. W. STANBROUGH
H. L. FARROW

CARTER, HOWE & CO.

MANUFACTURERS OF

GOLD JEWELRY



ARTISTIC—SALABLE—RELIABLE

Most Comprehensive Line Offered

9-11-13 Maiden Lane, New York

Factory, Newark, New Jersey

THEBERATH & CO., Inc.

Manufacturers of unusual, exclusive and salable designs in 14k. gold

**Brooches, Festoons, Handy Pins,
Barrettes, Pendants, Veil Pins,**

in beautiful plain patterns, or set with precious and semi-precious stones.

KENT & WOODLAND, SELLING AGENTS

12 John Street,

NEW YORK CITY

The Allsopp Rings

The Up-to-Date
Line of **Signet and Set Rings**



In twenty years we have built up a business second to none in
RINGS EXCLUSIVELY

Allsopp

QUALITY,
DESIGN AND
WORKMANSHIP

Appeal to the Most Fastidious.
It Will Pay You to Examine
a Selection Package.



A ★
TRADE-MARK.

Allsopp Bros. Allsopp Building, Newark, N. J.



A 10-K Line That Is 10-K.

Easter

Crosses

We make the largest and most varied line of Fine Gold Jewelry shown to the Jewelry Trade.

The Keller Jewelry Mfg. Company

Factory, Newark, N. J. 64 Nassau Street, New York

"THE BRACELET HOUSE"

GOLD BRACELETS of every kind
For WOMAN, MISS OR BABY

KENT & WOODLAND

16 John Street, New York

Factory: Newark, N. J. San Francisco: Julius A. Young



SEED-PEARL NECKLACES IN ALL SIZES.

OSMERS-DOUGHERTY CO.

MANUFACTURING JEWELERS

291-293 SEVENTH AVE., NEW YORK

Bet. 26th and 27th Sts. Telephone, 918 Madison.

DEALERS IN
BAROQUES, PEARLS and
FANCY STONES



DESIGNING
AND
SPECIAL ORDER WORK

Ludwig Nissen & Co.

182 and 184 BROADWAY
NEW YORK

PEARL
NECKLACES
AND
DIAMOND
COLLARETTES

Mounted Diamond
Jewelry of Every
description :: ::

Largest assortment
of all kinds of very
fine, fancy and rare
gems, including
Pearls, Diamonds,
Emeralds and
Sapphires :: ::

PARTICULARLY
FANCY COLORED
AND FANCY
SHAPED DIAMONDS

Ludwig Nissen & Co.

182 and 184 BROADWAY
NEW YORK

Easter Lily Hat Pin



THIS is one of the most felicitous creations ever placed at the disposal of the trade.

Made in approximately the size shown above, as well as smaller. Also in cluster form.

Baroque Pearl center. Some with diamond "dew drop."

Scarf Pins in same form.

Prices moderate



Day, Clark & Co.

Makers of 14-Kt. Jewelry

23 Maiden Lane
NEW YORK

NEW DESIGNS IN HANDY PINS



Made in all colors
and finishes



Greatest variety of
designs and
sizes

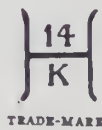

TRADE-MARK

A. J. HEDGES & CO.

Makers of Exclusive Designs
in High Grade 14K. Jewelry

14 JOHN STREET, NEW YORK

I. N. LEVINSON, President

ESTABLISHED 1865

H. S. MORRIS, Sec. and Treas.

S. COTTLE COMPANY

Makers of High-Grade Gold, Silver, Gun Metal Novelties

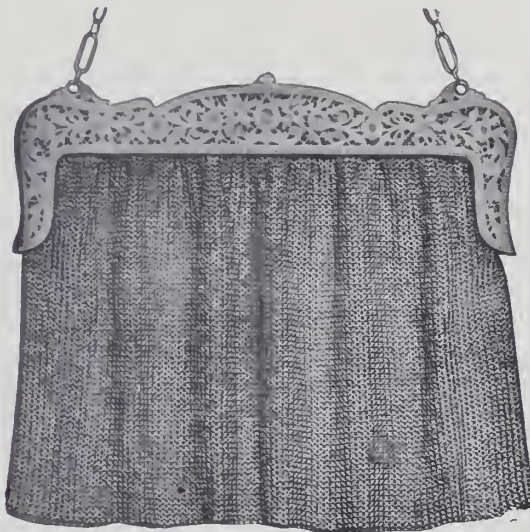

Mesh Bags Buckles

Card Cases Chatelaines

Vanity Cases Sash Pins

Purses Hat Pins

S. COTTLE CO.

31 EAST 17th STREET
NEW YORK

PARIS, 28 Rue D'Hauteville



SNOW & WESTCOTT CO.

21 MAIDEN LANE, NEW YORK

JAMES P. SNOW

CHAS. E. WESTCOTT

Makers of Fine Gold Jewelry

ESTABLISHED 1834

"If It Is Chopard's Idea, It's Ideal"

ALL
QUALITIES

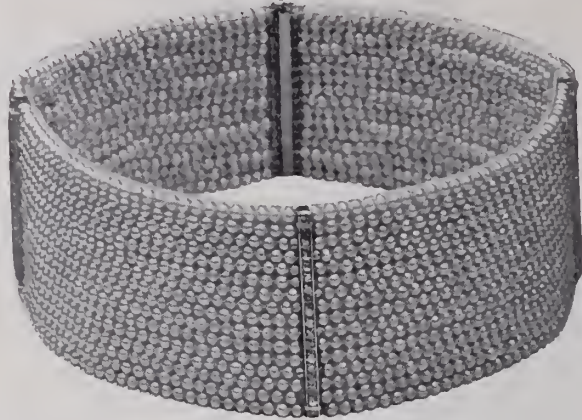

ALL
SIZES

OUR PEARLS resemble others only in name. Here the comparison stops, for in Quality, Lustre and Durability they defy competition. COLLARS, NECKLACES, FAN CHAINS in stock.

Remember our Special Department created for you. For Restraining and Mounting Pearls and Pearl Collars AT MODERATE RATES.

CHOPARD FRÈRES

Factory, 35 Rue des Trois Bornes,
PARIS, FRANCE

56 Maiden Lane,
NEW YORK, N. Y.

SKILFUL REPAIRING

We have added a Repair Department to our factory, under the supervision of a highly competent man. Repairing of HEIRLOOMS and ANTIQUE Jewelry will be our specialty. We solicit only high class repair work requiring the most careful attention and skilful workmanship.

SCHULTZ & CO. INC.

Factory and Office
91 Oliver Street, NEWARK, N. J.



New York Salesroom
12-14 JOHN STREET

MAKERS OF BUSINESS BUILDERS

After July 1st, 1908, this Company will change its name to

LAYMAN & STRAUS CO.

PERCY M. LAYMAN

SYDNEY C. STRAUS

Send for the Latest Styles in

MONOGRAMS AND INITIALS

as manufactured by

THOMAS J. DUNN CO.

101 Chambers St., New York

Makers of exclusive styles in

MONOGRAM FOBS

in Gold, Sterling and Rolled Gold Plate. Our 1908 Ladies' Belt Buckles are most original and artistic.

Specialties in the Monogram and Initial line.

Send for Illustrated Sheets.



CHARLES M. PRIOR, Designer

Designs for Gold and Silversmiths.

I have added Ornamental Engraving to my Etching Department.

'Phone 1639 Gramercy

24-26 East 21st St., NEW YORK



SOLID GOLD COMBS

From \$1.50 Upward

A Snappy New Spring Line

in

Plain and Engraved Bands,

also

New Effects in Pierced Tops

14k.—Everything in Gold Jewelry—10k.

Brooches, Barrettes, Buckles, Bracelets,

Pendants, Festoons, Emblems, Hat

Pins, Fobs, Scarfs, etc.



2 Maiden Lane,

New York



No. 58

THE ARCHIBALD-KLEMENT LINE OF

SILVER DEPOSIT WHISKY BOTTLES

Distinguishable for their dignity of design and excellence of finish. Made in full quart size, four designs—Narrow Strap, Broad Strap, Rye, Thistle. Shield space for monogram, sterling silver cork-screw tops. Highball and whisky glasses to match each design.

Full line of the foregoing, and any other desired pieces in the A-K Silver Deposit Ware, sent on approval.

ARCHIBALD - KLEMENT CO.

Sample Rooms: 341-347 Fifth Ave., N. Y.

Factory: NEWARK, N. J.

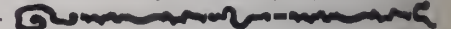

J. E. ROHRBECK
MANUFACTURER
40 FULTON ST.
NEW YORK, N. Y.

THE BEST
SOLID GOLD CHAINS

THE CHEAPEST

They stand the test of time and have done so for 56 years.

Supreme in
QUALITY
DESIGN
FINISH
WORKMANSHIP



We Sell Direct. We Have No Salesmen. Eliminating all unnecessary expenses in making and selling enables us to sell at the lowest possible price. Send for catalogue.



ALOIS KOHN & CO.
16-18 Maiden Lane, New York
Makers of **Gold Chains** of every kind

L. BONET, CAMEO PORTRAITS,



Importer of **Precious Stones,**
41 Union Square, NEW YORK.

Hill & Schmidt

71 NASSAU STREET - - - NEW YORK

Makers of Artistic 14 Kt. Jewelry



THE HAGERSTROM CO. (Incorporated)

Makers of
14-K Jewelry

Office and Works
276 N. J. R. R. Ave.
Newark, N. J.

¶ We are always adding something new and salable to our large line. We have no particular leaders as all our designs are not only original and up-to-date but beautifully made and finished.



No. 1093.

¶ Our Necklaces and La-Vallieres are sellers, because they are made at a price that will appeal to the careful buyer. *Seeing is believing.* Also included in our Spring offerings are Link and Cuff Buttons, with Scarf-pins to match, set with a variety of stones.



No. 325.

Finished in Rose and Enamel



No. 326.

Set with Amethyst, Jade, Amazonite, Red and Green Sardonyx, etc.

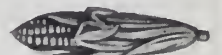

No. 324.

Set with Half Pearls and Enamel

DIAMOND MOUNTINGS

of any description in gold and platina

Order Work a Specialty

HENRY BASCHKOPF

47-49 Maiden Lane

New York, N. Y.



While your business is somewhat dull you will find it to your advantage to look up the local order for

CLASS PINS

Write us for Catalogue J 30, and Samples

THE CHAS. M. ROBBINS CO.

MANUFACTURING JEWELERS AND ENAMELERS
ATTLEBORO, MASSACHUSETTS

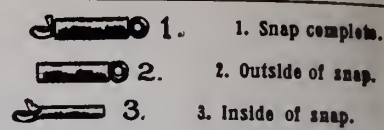

The E. P. H. Patent NON-PULL-OUT Neck Chain Snap

*is a patented snap that insures
the wearer against loss of*

CHAIN or CHARM for it positively will not pull out

**Made in 10 and 14 Karat Gold and
In Gold Filled.**

*Can be had of the following Wholesale
Selling Agents:*

Messrs. W. Green & Co.,
81 Nassau St., New York

M. Sickles & Sons,	Philadelphia
E. A. Cowan & Co.,	Boston
E. & J. Swigart,	Cincinnati
Swartzchild & Co.,	Chicago
Nordman Brothers,	San Francisco
Leonard Krower,	New Orleans
A. Walker Co.,	Providence, R. I.
Bauman-Massa Jewelry Co.,	St. Louis
H. S. Melsky Co.,	Lancaster, Pa.
The Edw. Lehman Jewelry Co.,	Denver, Col.

PRICES.

14 Karat—Small, \$7 per doz. net
Large, \$7.50 per doz. net

10 Karat—Small, \$6 per doz. net
Large, \$6.50 per doz. net

Gold Filled—Small, \$2 per doz. net
Large, \$2.25 per doz. net



Monograms

INITIALS AND FOBS

*Our
Specialties*

*Write for Catalogue
Prices and Discounts*



**CHICAGO
ART METAL
WORKS**

63 Lake Street,
CHICAGO, ILL.

MONOGRAM FOBS

TO THE TRADE:

in solid 14KT. GOLD—STERLING SILVER and extra heavy GOLD
PLATE mounted on silk ribbon or leather
PLATES AND PRICES ON APPLICATION

WALDRON & CARROLL, 34 Warren Street, New York

UNIQUE GEMS

SEMI-PRECIOUS CEYLON, URAL and NATIVE
GEMS My Specialty

*Prices the Lowest. Sample Papers sent on Request
to Reliable Jewelers and Manufacturers.*

Louis J. Deacon, Atlantic City, N. J.

Fans

in endless variety from the cheapest to the best, for weddings, confirmation and graduation.

SEND FOR SELECTION,
MENTIONING PRICE



Novelties for Easter

in Necklaces, Buckles, Belt Pins, Brooches, Hat Pins, Collars, in sterling silver and gold plated, set with semi-precious and imitation stones: lapis, coral, amethyst, topaz, etc. Also an extensive line of Cameo Jewelry.

Pearl Drop Earrings

LEWY & COHEN
IMPORTERS

530 Broadway Cor. Spring St.
NEW YORK

The Bowden Rings

ARE COMPLETE IN VARIETY, CORRECT IN QUALITY AND PERFECT IN FINISH. WE MAKE EVERY VARIETY OF FINGER RINGS.

J. B. BOWDEN & CO.,

1 Maiden Lane,

NEW YORK.

New England Watch Repairing for the Trade

GEO. W. HYDE & CO.
101 TREMONT STREET
BOSTON, MASSACHUSETTS

Make a Specialty of Repairing
New England Watches

Work returned in one week, and guaranteed to be satisfactory in every respect. Recommended by The New England Watch Co.



306

S. PITZELE

Established 1893

51-53 Maiden Lane, New York

MANUFACTURER OF

FINE DIAMOND MOUNTINGS

Also BRACELETS and DWT. GOODS

SPECIAL ATTENTION GIVEN TO ORDER WORK



218



325



435

TRADE **14K** MARK

CORAL HAT PINS

The spring season and Eastertide are here, and as usual there will be a big demand for hat pins. Coral jewelry is popular in the extreme, and our line of Coral Hat Pins, showing hundreds of new designs, is one of the finest showings on exhibition at present. The prices range from \$6.00 to \$24.00 per dozen.

SELECTION PACKAGES SENT ON REQUEST

M. GUGENHEIM,
IMPORTER

Brooches, Festoon Chains, Combs, Hat Pins, Collars, Jet Goods, Mesh Bags, in German Silver, Gilt Metal and Sterling

NEW YORK OFFICE: 33 Union Square, Decker Building

PARIS: 32 Faubourg Poissoniere

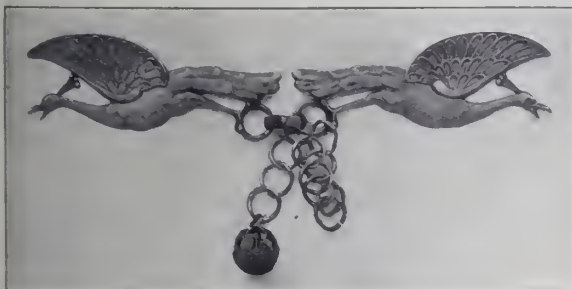

LOCKETS ONLY

Registered



U. S. Pat. Office



Pat. Applied for
NUMBER
8482

Latest Design Appropriate for Easter

WIGHTMAN & HOUGH CO.

NEW YORK OFFICE
3 Maiden Lane

Main Office and Factory } 7 Beverly St.
PROVIDENCE, R. I.

EVERYTHING IN LOCKETS AND CHAINS.

THE BASSETT JEWELRY CO.,

PROVIDENCE, R. I.

Roger Williams Silver Co.,

PROVIDENCE, R. I.

Sterling Only.

RICH DESIGNS :: :: :: Photos. on Application.

S. F. Myers & Co.

WHOLESALE JEWELERS

47-49 Malden Lane

New York

The only way we fool our customers is to give them more than we promise, and more than they expect.

For the trade only — our new, big catalogue, with 100,000 items, sent free.

THE WASHBURN

SECURITY **MAGIC NUT**
Automatic Holder for ear studs, scarf pins etc.
for all sizes of scarf-pin wire. Guaranteed.



EAR WIRES
for unpierced ears.



SAFETY CATCH
For Brooches, etc.
Can be applied to any work where pin tongue are used.

Open. Closed. Open. Closed.

Descriptive Circular on Application.

Pearl Drilling and Adjusting a specialty.

Special Order Work and Repairing.

C. IRVING WASHBURN, 12-16 John St., N. Y.

THE GREAT AMERICAN JEWELRY CATALOG

Is a publication of real practical value; it truthfully illustrates those lines of merchandise; best adapted to the needs of the *Jewelry Trade*; its reliability is unquestionable.

SAFETY

With implicit confidence you can use it when ordering goods; it insures you against deception; remember, for every dollar's worth of merchandise you buy you are obtaining positive, intrinsic value.

Write for this catalog; it means much to you.

THE OSKAMP-NOLTING CO.

Mammoth Wholesale Jewelers

411-413-415-417 Elm St., CINCINNATI, OHIO



Try Wells' Perfect Ring Adjuster

1 doz. asst. sizes 10k gold filled (gold on front twice as thick as on back), \$2.0
1 doz. asst. sizes solid 10k gold, \$3.7
1 doz. asst. sizes, metal, 85c. Ask your jobber for them, or I will send, prepaid at once (only on receipt of price), two samples—one small and one medium large gold filled and one metal adjuster for 50c. Address

CHESTER H. WELLS, Jeweler, Meshoppen, Pa.

Orders Prove Our Goods Sell

Q We make for the Jobbing Trade the following lines of Solid Gold Jewelry:

Rings, Scarf Pins, Studs, Brooches, Charms, Baby Pins, Handy Pins, Chain Sets, Link Buttons, Hair Barrettes, Crosses, Ear Screws, Pierceless Drops, Cameos in all styles, etc.

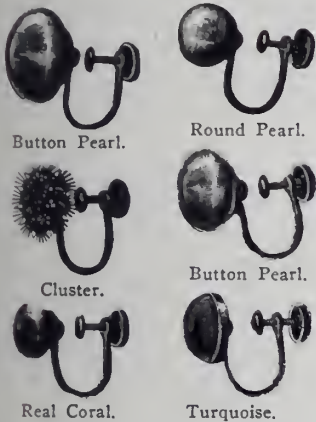

Button Pearl.

Round Pearl.

Cluster.

Button Pearl.

Real Coral.

Turquoise.

Insist upon seeing the designs of Gold Jewelry made by the

E. L. Spencer Company

95 CHESTNUT STREET
PROVIDENCE, R. I.

NEW YORK OFFICE
9-11-13 MAIDEN LANE

(SAMPLES ONLY.)

CUFF BUTTONS
 IN EVERY POSSIBLE VARIETY
 WE ARE THE LARGEST EXCLUSIVE MAKERS OF 10-K JEWELRY.
 ASK YOUR JOBBER FOR P. & B. LINES OF
 Cuff Buttons, Crosses, Beadnecks, Tie Clasps,
 Brooches, Baby Pins, Scarf Pins, Bracelets,
 Locketts, Fobs.

NEW YORK
 OFFICE
 65 NASSAU ST.

POTTER & BUFFINTON CO.
 PROVIDENCE, R. I.

**Sterling
Silver
Horseshoes**

14 Karat
Gold Finish
set with
Whitestones
or Pearls

Write for Selection
Package with
Prices

Wachenheimer Bros. 36 GARNET STREET
PROVIDENCE, R. I.

WM. SMITH & CO.
 OFFICE: Established 1854. MANUFACTORY:
 9-13 Maiden Lane, New York 61 Peck St., Providence, R. I.

Manufacturers of GOLD AND SILVER CHAINS
 GOLD, SILVER AND PLATED CHAIN TRIMMINGS

Also GOLD AND SILVER
 KEY CHAINS AND
 BRACELETS



Easter Offering

Sold by

VERIBEST
JOBBER
EVERYWHERE

New York City, 9-11-13 Maiden Lane
Providence, R. I., 100 Stewart Street
Chicago, Ill., 131 Wabash Avenue

VERIBEST

Label Inside  Lifetime Guarantee

LOCKETS

As New As the Spring

Everything is relative—Lockets that are in style are worth buying.

There's a "Snap" that sells **VERIBEST**—A selling "Snap" in a locket means strength.

S. & B. L. ★ CO.

Quality Wears "Goodasgold"

Perennially
Popular

THE best evidence of the popularity of our various lines is the increasing demand for them and our consequent growth. Our jewelry is unexcelled in every quality that contributes to serviceability and appearance. The designs are artistic enough to court that investigation which results in sales.



No. 1117

Ask to see our line of

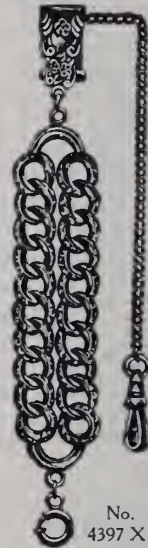

CHAINS
CHAIN PENDANTS
CROSSES
AND BRACELETS

The
Kenilworth
Bracelet

particularly, the strongest on the market.

DORAN,
BAGNALL & CO.

North Attleboro, Mass.

OFFICES

New York: 194 Broadway.
Chicago: 42 E. Madison St.
San Francisco: 91 Drumm St.

No. 4397 X1



CAMEOS

IN these times the jobber, in order to stimulate his business, must create a run on some special article. And just now, why not the Cameo? It is sure to be a good leader and is being extensively advertised by a number of manufacturers.

We are mounting stone, shell and coral Cameos in scarf pins and brooches. A good assortment of Cameos should be found in every line this season. Let us send you a few samples on memorandum.

R THIS TRADE-MARK on every piece of jewelry that leaves our factory. A medium-priced line of 10K. jewelry that has stood the test. Will say no more, but let us show you and be convinced yourself.

Send for further information regarding our extensive line.

W. E. RICHARDS CO.

Manufacturers for the Jobbing Trade
ATTLEBORO, MASS.

New York Office: 12-14 John Street Samples only

10K. GOLD BRACELETS

New and Original
— Designs in —

BANGLE, JOINT
AND
CATCH SIZES

Scarf Pins, Ladies' Ring
Earrings and Handy Pins

In a great variety
of designs

TRADE MARK

THE
Edwin Lowe & Co., Inc.
F. W. BODWELL, Pres. & Gen. Mgr.

116 Chestnut St., PROVIDENCE, R. I.
New York Representative: Western Representative
E. T. Wilson, 180 Bway. S. H. Brower

THE CROWN PATENT SAFETY GUARD



For Scarf Pins, Pins. The most practical and adjustable one invented. Price, \$1.50 per doz. For sale by all wholesale jewelers and material houses. Same by mail, 25c.; in 10k. gold, \$1.00; 14k., \$1.25. M. CROWL Maker and Inventor, 48 and 50 Maiden Lane, N. Y.

SEND YOUR SWEEPS to the
Cincinnati Gold & Silver Refining Co.
REFINERS, ASSAYERS AND SMELTERS

Office, 523 Elm Street; Works, 2257 Eastern Avenue; CINCINNATI, OHIO

Highest Price Paid for Gold, Silver and Platinum Platinum and Gold Fillings Refined by the Russian Method



O. M. DRAPER CHAINS

ALL KINDS OF VEST CHAINS
PRINCESS, NECK AND GUARD CHAINS

We do not make as much noise as some of our friends but we are "there with the goods" and the *Jobbing Trade* handling our product for the last half century, know that our **QUALITIES** are genuine and can be depended upon, that our **FINISH** is unparalleled and that our prices are consistent.

If you do not handle O. M. DRAPER GOODS, we both lose.
We sell only to the Jobbing Trade.

Estate of O. M. DRAPER
Factory, No. Attleboro, Mass.

NEW YORK OFFICE
37 Maiden Lane

SAN FRANCISCO
506 Chronicle Building



Don't Worry About the Scarcity of Money

If you need any send us your surplus stock of Diamonds, Watches, Jewelry, Old Gold and Silver, and get our certified check by return mail. If amount is not satisfactory goods will be returned in same condition as received. Strictly confidential. Correspond or call. Telephone, 5202 John.

New York Jewelry Purchasing Co.
106 Fulton Street, New York

ARREAUD & GRISER
68 & 70 Nassau St., New York
LAPIDARIES. PRECIOUS STONES
GEMS in Unique Cuttings

PRACTICAL COURSE IN ADJUSTING

Published Price, \$2.50.
Special Reduced Price, \$1.50, Postpaid.

The Jewelers' Circular Pub. Co., 11 John St., N. Y.



SHUROLDA



Automatic Scarf Pin Protector



14 Kt. Gold Plate

Price 50 Cents

To Release Pull the Ball

To Release Pull the Ball

Pat. Mar. 12, 1907.
No. 847,164.

The Stronger the Pull the Firmer It Holds

Pat. Mar. 12, 1907.
No. 847,164.

Samples and Prices on Application

FOR SALE BY JOBBERS OR DIRECT BY

STERN & CORN, 71-73 Nassau St., NEW YORK

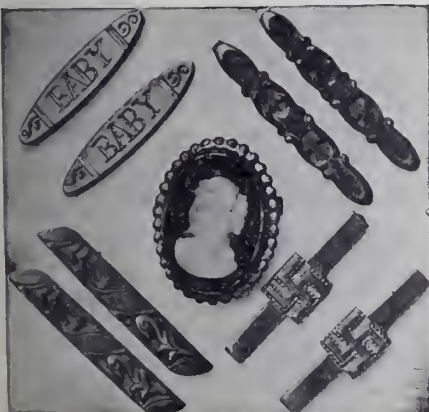

Veil, Cuff and Baby Pins

An immense line. Many new designs supplementing our staple patterns—all of acknowledged beauty and easily sold.

Cameos A revival of an old-style decoration too good to remain in oblivion.
Shell, Coral and others, mounted as Brooches, Stick Pins, etc.

Swastika Buckles Bracelets Buttons Charms Brooches Barrettes
Combs, Hat Pins, Scarf Pins, Leather Trimmings

MILLER, FULLER & WHITING CO.
Manufacturing Jewelers
New York Office, 9-11 Maiden Lane NORTH ATTLEBORO, MASS.
WE SELL TO THE JOBBING TRADE ONLY



The Thimble House.



No. 149.

Thimbles are not a side line with us—They are our main business. We study Thimbles, our designers study thimbles, our workmen study thimbles—The result is the finest and largest line of Thimbles on the Market.



No. 136.

KETCHAM @ McDOUGALL,

Manufacturers,

37 @ 39 Maiden Lane, New York.

Send for Catalogue.

Established 1832.

ALSO MAKERS OF THE NEW AUTOMATIC EYE-GLASS HOLDERS.

"GOLD MEDAL"

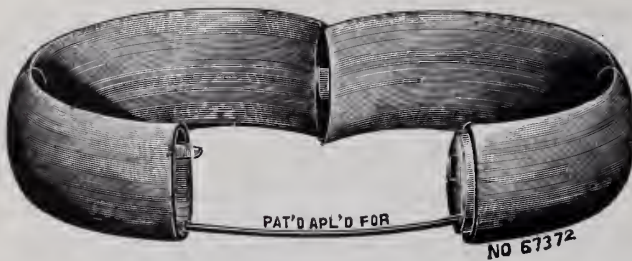

Try Them

If for the first time—

To buy them once means to repeat.

"Geraldine Farrar" "SECURON" Hinge Bracelet

Guarantee "Pr. St. Co." Mark Inside

PROVIDENCE STOCK CO.

9-11-13 Maiden Lane
NEW YORK CITY

100 Stewart Street
PROVIDENCE, R. I.

131 Wabash Avenue
CHICAGO, ILL.

JANITSCHKE COMPANY, Inc.

33 UNION SQUARE, NEW YORK CITY

Manufacturers of Patented **DIES** for the Silver and Metal Trade

ARTISTIC CASTINGS OF EVERY DESCRIPTION FOR THE SILVER AND JEWELRY TRADE

Iron Hubs and Bronze Forces, False Core Work and Undercut Castings with Elastic Patterns. Fine Plaster Castings by the *Janitschke Patent* Superior to the Asbestos Process

TELEPHONE, 400 STUYVESANT

We have the most approved Reducing Machines

Crees & Court
Die Sinkers

21 Eddy St., Providence, R.I.

DIES

FOR

JEWELRY SILVERWARE

Medals
Emblems
Brass Goods

Write us for a Selection of DESIGNS



Fancy Platforms and Blocks for Window Display.

Trays, for Show Cases and Travelers' Use, of every description.

Jewelry Boxes in many qualities and styles.

Boxes for silverware. Manicure and Toilet Sets.

Silverware Chests in any combination.

Flannel Rolls and Bags for Silverware.

We Re-cover Window Platforms and Trays.

PAPER BOXES.

Tags, Cards, Cotton, Findings, Etc. Estimates and Samples Cheerfully Furnished

WOLFSHEIM & SACHS

Office and Salesroom:

35 Maiden Lane,

(Lorsch Building)

NEW YORK

Factory: 10 Gold Street, N. Y.

A NEW CREATION IN

Hat Pins



Made of the finest brilliant Rhinestones. Can be sold for less than the imported ones. They come in pear, ball and half ball, octagon and heart shapes, and can be retailed from

50c.

to

\$5.00

at a handsome profit. Ask your jobber or write us for sample assortment.

ACME COMB AND NOVELTY CO.

Manufacturers

Factory and Office

147 Spring St., New York

Salesroom: 194 Broadway

Trade-Mark.

Trade-Mark.

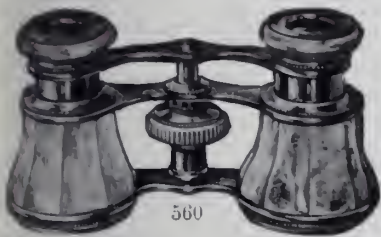

COLMONT OPERA and FIELD GLASSES

have been recognized by Opticians who really wanted a good article without paying too high a price.

With Colmont Glasses
You Have a Guarantee

The name STANDS for honesty and uniformity of construction, fairness of price.

For your own advantage, investigate the "COLMONT" line at your jobber's.

**SUSSFELD, LORSCH
& CO.**

Importers

NEW YORK

PARIS

The Latest Novelty in Cloisonne Enamel

STERLING SILVER WITH BEAUTIFUL TRANSPARENT COLORING

Birth Day Handy Pins



¶ We wish to call particular attention to this line and the rich effect produced with polished silver in combination with the enamel. This is the best hit of the season.

Price, \$7.50 per doz. mounted on an easel pad.

SHEPARD MFG. CO., MELROSE HIGHLANDS, MASS.

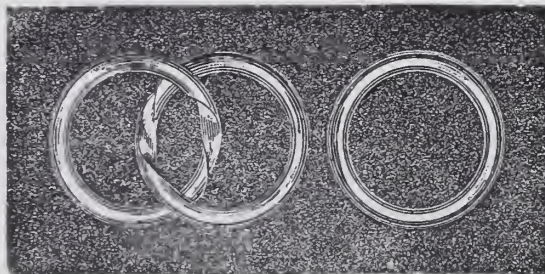

WE MAKE

The Alliance Ring

The graceful style of the Alliance Ring is rapidly supplanting the use of the old style wedding ring. The joints are invisible, and whenever engraving is desired it is done in the inside surface. Can be easily separated by inserting a pin in inside pin-hole.

14 karat, 3 dwts., each, \$1.25 per dwt. ; in dozen lots, \$1.15 per dwt., net.
18 karat, 3 dwts., \$1.40 per dwt. ; in dozen lots, \$1.30 per dwt., net.

MADE ONLY BY

LEONARD KROWER, Manufacturing Jeweler

536-538 Canal Street

New Orleans, La.

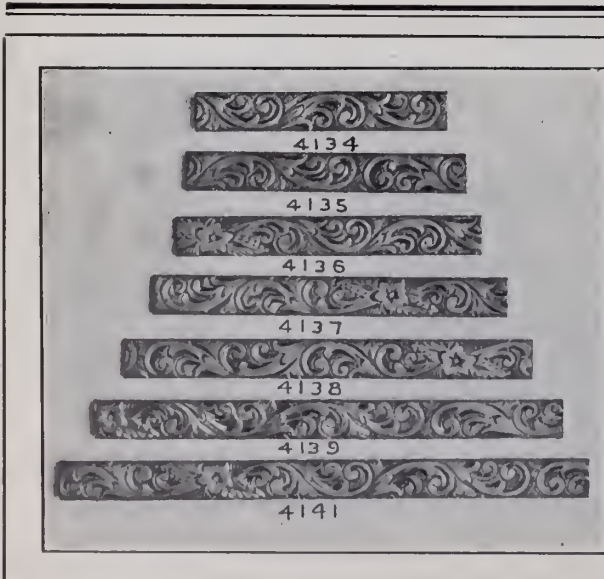
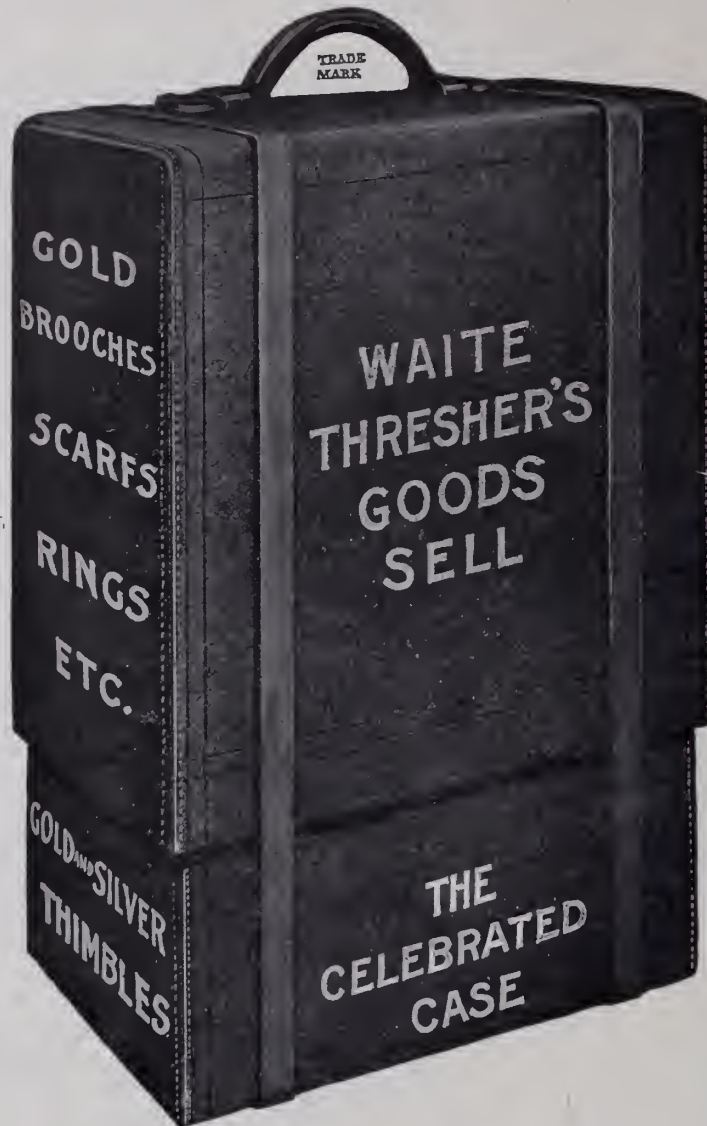

Seamless Gold Plated Pins

FOR EVERY USE

Variety of Patterns in Plain and Engraved, in lengths one to four inches : : : : :

GUARANTEED GOLD FRONT, BACK AND SIDES

SEND FOR SELECTION

Maintien Bros. & Elliot, Makers of Jewelry for the Jobbing Trade

NO. ATTLEBORO, MASS.
New York Office, 9-11 Maiden Lane

Recently Published

Gems and Precious Stones

Their Characteristics, Localities of Production Tests and Some Current Literature

Cloth, Postpaid, \$1.00

Published by
THE JEWELERS' CIRCULAR PUB. CO.
11 John Street, New York



The Gillette Safety Razor Set consists of a triple silver-plated holder and twelve double edged, thin, flexible, wafer-like blades (24 keen edges), packed in a velvet lined leather case. Price, \$5.00. Also made in Combination Sets in a variety of styles with toilet accessories retailing from \$6.50 to \$50.00 each.

Would You Have the Present Year Bring You Increased Patronage, Profit and Prosperity?

Do you realize that nearly every hour in the day some man is converted to the easier, quicker and more economical way of shaving himself with the

Gillette Safety Razor?

Our persistent and vigorous advertising in the leading publications of this country discloses — *and will continue to disclose* — beyond all question of doubt, the superiority of the "Gillette." It advocates the advantages of self-shaving and guides the man to your store with a five dollar bill to exchange for the best shaving device in this world.

You can readily see the wisdom of having the "Gillette" ready when he calls. The Standard Gillette Set retails at \$5.00 everywhere. Combination Sets from \$6.50 to \$50.00. Keep a good supply in stock. Write to-day for valuable selling information and prices.

GILLETTE SALES CO., 904 Times Bldg., New York City



Scarf Pin 891
Old English
Set as ordered

Scarf Pin
842—Rose
or Green
Set as
ordered

Neck Chain 296
Old English Chain
Roman Scrolls
16" long
Stones set as ordered
Baroque Pearl
Pendant

Link Button
877—Rose, Ruby
and Brilliants
878—O.E., Ruby
and Brilliants

Link Button
872—O.E., Stones set
as ordered



Charm 2982
Rose, Ruby Stones

Easter Suggestions

We have this season many choice designs in Fine Gold Filled Jewelry, suitable for Easter gifts, among which are Neck Chains and Pendants, Locketts and Charms, Link Buttons and Bracelets, as well as Brooch, Veil, Scarf and Hat Pins. Our Gold Filled Goods meet the most critical test for high standing.

We mention our Sterling Silver Toilet, Manicure and Table Goods as appropriate Wedding Gifts.

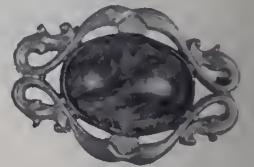

Brooch Pin
3864—Old English, Japanese
Jade Stone



Scarf Pin
884 - O.E.
Set as
ordered



Scarf Pin
886—O.E.
Set as
ordered



Locket
3013 Rose, No Stones
3016—Rose, Red Eyes,
White Mouth



Belt Buckle
3540²—Rose, Ruby Eyes, Stone in Mouth set as ordered, Pin Stem
3540 —Rose, Ruby Eyes, Stone in Mouth set as ordered, Clasp

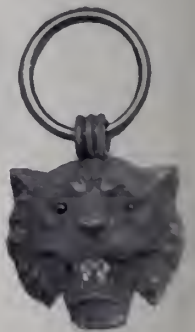

Charm
2984—Rose, Red Eyes,
White Mouth
2983—Rose, No Stone

Theodore W. Foster & Bro. Co.

Manufacturing Jewelers and Silversmiths

100 RICHMOND ST., PROVIDENCE, R. I.

NEW YORK: 13 Maiden Lane

CHICAGO: Heyworth Bldg.

CANADA: Kingston, Ontario

Beautiful Sterling Silver Banquet Service Presented to the United States Battleship "Montana."

THE beautiful sterling silver banquet service for the United States battleship *Montana* illustrated in this issue, is worthy of special remark for the discrimination manifested in the selection of the pieces. Instead of superfluous and uninteresting service dishes or a lot of feminine tea-party trifles dear to the hearts of souvenir fiends, the appropriation has been confined to generous and substantial vessels of rich and dignified design.

In point of design the service is in the style characteristic of the great French masters of the 17th and 18th centuries, but without slavishly following the detail of any particular tradition, it embodies ele-

pieces: Large punch bowl and plateau, 30 crystal cups and ladle; small punch bowl and ladle; pair of candelabra; pair of compotiers; pair of sandwich dishes; pair of

States, worked in enamel. The upper edge of the bowl has a massive mount in which the detail is the dolphin and shell treated in the ornamental manner with scroll and foliated decoration.

On the front of the main body is a large etched picture of the battleship *Montana* with a heavy ribbon scroll above bearing in relief the wording, "U. S. S. *Montana*, A. D. 1908," and above this the crossed flags of the United States and the State of Montana, worked in enamel. On either side of this central panel is a group of mining implements with cornucopias (emblems of prosperity), from which issue sprays of the bitter root, the State flower of Montana. These support and frame the seals; that on



THE SMALL PUNCH BOWL.



THE COFFEE URN.



PAIR OF BOTTLE HOLDERS.

ments and motives growing out of the special circumstances attending its inception. The historic, scenic and industrial features of the State are illustrated by typical scenes and pictures which further exemplify by comparison the wonderful progress she has achieved; the sea is represented in symbol and emblem; the vessel itself is commemorated on many of the pieces, and the seals of the State and of the Navy Department repeatedly testify to the official character of the gift. The State flower, the bitter root, is incorporated in each of the detail of the ornament.

The pieces are all hand wrought, of massive sterling silver and exhibit the highest order of workmanship throughout. The larger raised ornaments have been wrought separately and applied on, as it was considered inadvisable to break up the interior surface of the vessels. The subsidiary ornament is repoussé in relief, and scenes and descriptions are etched in most cases in relief. The exterior finish is in gray, oxidized to show the elaborate detail. The punch bowls, ladles, compotiers and similar pieces are richly gold lined.

fruit baskets; pair of serving trays; pair of bottle holders; coffee urn; cigar box.

The large punch bowl, which, with the plateau and base, is illustrated on the front cover of this issue, is of a general oval form about 27 inches wide and has a capacity of 44 pints. The piece is massive and elaborate and embodies in its rich symbolic detail emblems of the State, navy and nation. At each end the body of the bowl is carried out into a decorative form suggestive of the prow of a vessel, on which is poised a splendid monumental eagle standing guard over the shield of the United

the left of the picture being the seal of the Navy Department, and on the right the great seal of the State of Montana. On the reverse side of the bowl in the panel corresponding to the ship is a carefully executed picture of the fine State House at Butte, Montana. The lower portion of the body is richly decorated with shell work and trailing masses of seaweed.

The bowl is supported on four large dolphins. The lower edge of the foot is of heavy scroll work in detail with sprays of oak, emblems of strength and hospitality. The other pieces illustrated herewith include the small punch bowl, the coffee urn, a cake basket and one of the bottle holders.

The service was designed and executed at the Reed & Barton factories, Taunton, Mass. The order was secured through Huber Bros., Dillon, Mont. It has been on exhibition at Reed & Barton's Fifth Ave. store and is now on view at the Maiden Lane branch, New York.

The vessels of the United States Navy whose presentation services have been illustrated and described in *THE JEWELERS' WEEKLY*, and the dates of the issues in which these illustrations and descriptions



EVERY BUSINESS DAY

we receive broken shirt studs to be repaired, of some other manufacturer's make. Because the studs have a spring in them some jewelers think we are the makers. Nearly all of them are so poorly made that the manufacturer is ashamed to father his own offspring and does not put a Trade-Mark on them for identification.

To the contrary, the Larter Shirt Stud has stamped on the barrel of each our United States Registered Trade-Mark, which is our guarantee that there is absolutely no better shirt stud made, and that we cheerfully give a new one if an accident happens.

This applies to 18K. and 14K. gold, also 10K. gold and 14K. gold filled. These last two lines to be had from progressive jobbers.

Why not carry in your stock the largest and best line of shirt studs made?

LARTER & SONS

21-23 Maiden Lane, New York, N. Y.

TRADE-MARK



REGISTERED IN U. S. PATENT OFFICE

appeared from time to time, are as follows:

VESSELS.	ISSUE
Maine	June 3, 1891
Detroit	July 2, 1892
Montgomery	Feb. 15, 1893
Cincinnati	Sept. 26, 1894; April 24, 1895
Minneapolis	May 1, 1895
Brooklyn	Feb. 12, 1896
Nashville	May 13, 1896
Iowa	July 22, 1896
Raleigh	Oct. 7, 1896
Oregon	April 28, 1897
Massachusetts	June 9, 1897
Wilmington	Dec. 1, 1897
New Orleans	June 7, 1899
Kentucky	June 28, 1899
Olympia	July 26, 1899
Indiana	Aug. 30, 1899
Marietta	Sept. 13, 1899
Wisconsin	May 16, 1900
Illinois	May 17, 1901



ONE OF THE FRUIT BASKETS.

New York	May 22, 190
Alabama	Nov. 26, 190
Albany	Feb. 11, 190
Denver	March 18, 190
Pennsylvania	June 24, 190
South Dakota	April 20, 190
Tacoma	June 29, 190
Ohio	Aug. 2, 190
Nebraska	Aug. 30, 190
Missouri	Sept. 6, 190
Kansas	Sept. 13, 1905; June 26, 190
New Jersey	Oct. 18, 190
Milwaukee	Oct. 25, 190
Maryland	Nov. 8, 190
Charleston	Feb. 14, 190
Connecticut	March 14, 1906; Nov. 21, 190
Tennessee	Nov. 7, 190
Virginia	Nov. 14, 190
Louisiana	Dec. 19, 190
Vermont	Jan. 2, 190
Chattanooga	Feb. 13, 190
Washington	Feb. 27, 190
Georgia	June 12, 1907; June 19, 190
Rhode Island	Sept. 4, 190
Paducah (punch set)	Feb. 12, 190
Montana	March 25, 190

REPOUSSÉ WORK AND CHASING*

ILLUSTRATED AND DEMONSTRATED BY AN EXPERIENCED ARTISAN

(Continued from issue of March 18.)

DRINKING cups used at the great feasts and entertainments periodically arranged by the great nobles were often of a very elaborate description. They were at this period generally made with a cover. A very beautiful covered drinking cup of Burgundian or Flemish workmanship of the 15th century is to be seen in South Kensington Museum. It is of silver, beaker shaped, surmounted by a conical cover. The most interesting feature of this cup is the transparent enamel work round the body and cover, consisting of foliage patterns, interspersed with windows of Gothic tracery, through which the light shines with fine effect.

In France the use of gold and silver in personal adornment became so great that King John, in 1356, prohibited the goldsmiths from making gold or silver plate or jewelry over a certain weight, except for the churches. This had very little effect, and his son and successor, Charles V., died in the possession of a treasury containing innumerable objects of the goldsmith's art of enormous value. The wealth in plate and jewelry possessed by the princes and nobles can be estimated by some of their inventories still in existence. The inventory of plate belonging to Louis, Duke of Anjou, drawn up between 1360-1368, comprises 717 items, and this is not all, as some of the leaves are missing. Very little of these immense collections have survived to our time, partly because during the Renaissance large quantities were melted down to be remodeled according to the taste of the time; and with very few exceptions what then remained was melted down during the civil wars of the 17th century and turned into money to pay the expenses of the various campaigns.

Among the more important secular objects produced in great abundance by the silversmiths of the Middle Ages may still be mentioned the salt cellar and the nef. The salt cellar was of considerable size, made in all kinds of forms, often in that of a dog or other animal, and generally with a cover. The nef took the form of a miniature ship, and was used for spices and sweetmeats; it stood in the center of the table, and occupied the same position as the épergne in modern times.

Before proceeding with the review of the Renaissance period, it will be of advantage to trace briefly the history and development of metal work in England from the time of its occupation by the Romans until the end of the Gothic period (15th century).

It is fairly certain that the art of working the precious metals was first introduced by the Roman colonists, although the making and working of bronze had already long been established in Britain. From remains still in existence it is evident that

early English work, until the time of the Saxon invasions, was more or less copied from Roman, and, later, Byzantine models. With the downfall of the old Roman Empire and the evacuation of England by the Romans, British art, no longer under the influence of a strong civilization and thrown into confusion by the continuous invasions by barbaric tribes which now occurred, rapidly degenerated and practically died out. On the restoration of comparative peace, the working of the precious metals was again slowly developed by the Saxons, but it was essentially a revival art, as very little of the old school of metal work that had been developed by the Romans still existed. By the middle of the fifth century the metal work made by the Saxons had



THE ALFRED JEWEL.

reached a high standard of excellence, and, apart from certain marked Teutonic features, bore closer resemblance to classical art than the metal work made in other parts of the country. One of the finest examples of the work of this period is a gold buckle found in an Anglo-Saxon barrow at Taplow, in Buckinghamshire, and now in the Anglo-Saxon room of the British Museum.

From old records and manuscripts we learn that before the dissolution of the Heptarchy by Egbert, the goldsmiths' art in England was well developed and in a flourishing condition. The ring of King Ethelwulf, in the British Museum, is of gold and has his name cut in plain Roman letters, filled in with blue-black enamel. It is of Saxon workmanship of the eighth century, and shows that champlevé enameling was practiced in England at that time. The development of metal work in England during the eighth century owed much to the prelate Alcuin, who was famous for his learning and accomplishments all over western Europe. He founded many monasteries which, at that time, besides being the chief seats of learning, were the centers for the production of crosses, shrines, reliquaries and other objects in metal intended for church use.

In the following century we get evidences of the gold and silver work made during King Alfred's reign (871-900), whose visit

to Rome in his youth had doubtless first given him his taste for learning and art. The only piece of silver plate of this period still in existence is a chalice from Trewhiddle, near Saint Austel. The celebrated "Alfred jewel," now preserved in the Ashmolean Museum, in Oxford, gives us a better insight into the style prevailing at that time. It was found at Athelney, in Somersetshire, where Alfred lived in retirement about the year 880. The face of this remarkable jewel is formed of a piece of rock crystal, about three-eighths of an inch thick, under which are figures representing the Saviour, St. Neod, St. Cuthbert and Alfred himself, executed in enamels. The box-like setting which holds the crystal is made of gold, and an inscription runs round the edge. It is boldly cut and reads: "Aelfred mee heht gevvr can" (Alfred ordered me to be wrought).

Following a period of general depression in the 10th century, England, with the rest of Europe, experienced a great artistic revival in the 11th century. Artists were no longer content with Byzantine models, but introduced a style of their own. During the succeeding two centuries the various ecclesiastical utensils connected with the church service, though in great variety, were all designed after certain general types and models. The interchange of visits among the inmates of the various monasteries scattered over western Europe, and, above all, the common interest taken in the crusades made craftsmen work out similar ideas, though often working far apart. The great abbeys of Ely and St. Albans in England, in common with the various abbeys of the Continent, were, so to speak, schools of ecclesiastical goldsmiths, and most of their motives of design, as well as the various methods of working, were common knowledge. About this time English art became influenced by the Norman tendencies of Edward the Confessor, and the Romanesque, or Norman, style eventually became supreme, after the overthrow of the Saxons by William the Conqueror. The goldsmiths' art at this time borrowed much from the architecture of the period. Stalks and leaves were twined round architectural columns, and tiny images of men struggling with dragons and other monsters were also used with good effect. The abbey of Ely about this time produced much work in gold and silver, and was eventually able to appease the anger of William the Conqueror by an offering of 1,000 marks, obtained by the sacrifice of a large number of gold and silver ecclesiastical objects which the abbey had accumulated.

(To be continued.)

John Williams, a negro, who claims to reside in Cleveland, O., was arrested a short time ago in Johnstown, Pa., after attempting to sell M. Bernstein & Co., pawnbrokers, located at 103½ Franklin St., for \$5, 10 pieces of silver, the value of one piece alone being estimated at \$100. Williams is about five feet four inches tall, 45 years old and rather dissipated looking. Among the silverware is a cream jug which is supposed to be an original design without a duplicate and very old. The initials "A. M. S." were found on all the pieces except a tablespoon, which was marked merely "S."

*All rights reserved. Copyright, 1907, in the United States by the Jewelers' Circular-Publishing Co., and in Great Britain by the Watchmaker, Jeweler, Silversmith and Optician.

LOUIS KAHN

MOSES KAHN

SAMUEL H. LEVY

L. & M. Kahn & Co.

Importers and Cutters of

DIAMONDS

170 Broadway, cor. Maiden Lane, New York

AMSTERDAM: 2 TULP STRAAT

CUTTING WORKS: 29 GOLD STREET

Arnstein Bros. & Co.

Importers and Cutters of

DIAMONDS

65 Nassau Street

New York

LONDON: Audrey House, Ely Place

AMSTERDAM: 6 Tulp Straat

ALBERT LORSCH

N. Y. Telephone Call, 2161-2 John

ALFRED KROWER

ALBERT LORSCH & CO.

LORSCH BUILDING, 37 and 39 MAIDEN LANE, NEW YORK

131 Washington Street, Providence, R. I.

CUTTERS OF
DIAMONDS

Interesting Patent Suit Over Clutch for Scarf Pins Begun in the United States Circuit Court.

An interesting patent suit has just been begun in the United States Circuit Court at New York, involving the question as to alleged infringements of a well-known clutch for scarf pins and other jewelry sold to the trade under the name of the "Hold-On." The suit also asks protection against imitations of the form and of the cards on which these clutches are sold. The suit is brought by Maximilian A. Fischer, the patentee, and Charles P. Goldsmith and Isaac Loeb, doing business as C. P. Goldsmith & Co., who manufacture the clutch. The defendants named are Isidor Berkson, J. A. Rainess, the United States Scarf Pin Guard Co., Abraham Rainess, John A. Abel, Edward A. Abel and Bernard Rainess.

The complaint, which is a long one, goes on to state who the defendants are, reciting that they have individually, jointly and severally committed acts of infringement from which the complainants have suffered. It is alleged that Mr. Fischer is the patentee of the clutch in question for which the patents were issued to him May 20, 1902, and that Mr. Fischer entered into an agreement with C. P. Goldsmith & Co. by which the latter obtained the exclusive right and license to manufacture these clutches, and that by virtue of this agreement C. P. Goldsmith & Co. have been and are now the sole owners of such rights.

The complaint then goes on to state that the defendants combining together within six years past have, without license or consent of the patentee or licensee, made and sold and are now selling clutches for scarf pins contending and embracing the invention and the improvements covered by the patent granted to Mr. Fischer; that the defendants have been notified of the infringement and requested to desist, but have failed to do so and threaten to continue to manufacture the alleged infringement.

The complaint avers that Fischer, though not a member of C. P. Goldsmith & Co., has an interest with the members of that concern in the profits of the business of the manufacture of these clutches carried on under the name of the Hold-On Clutch Co.; that the complainants have placed these clutches for scarf pins on the market in a certain form which was the result of many experiments and much study, and that the particular design adopted by them was new and original and not similar in appearance to any used in connection with clutches for scarf pins prior thereto; that this style has become well known and popular with the trade, and that the form and configuration of the complainants' device has become distinctive to the trade and to the public, and one of the most valuable assets of the complainants' business. They claim, therefore, that they are entitled to be protected in the use of the character and unique appearance of their clutches and scarf pins.

The complaint then cites an exhibit of the device manufactured by the defendants, which they claimed has the outward appearance of their own and causes confusion in the trade and in the minds of the purchasing public.

Then, upon information and belief, the complaint goes on to state that the defend-

ant combined for the purpose of unlawfully competing against the complainants by imitating the latter's goods, and that they have jointly and severally copied the form and configuration of the complainants' device for the purpose of deceiving the trade and public and reaping the benefit of the complainants' work, and that this permits of innocent purchasers being deceived and misled into buying the articles of the defendants for those of the complainants.

It is then alleged that the defendants have mounted and arranged their clutches, which now are exactly similar to complainants' in form, upon cards bearing a close resemblance to the cards of the Hold-On Clutch Co., and having the same general advertising matter, arranged in the same general manner as the complainants have followed since 1902; that such arrangement in copying, it is alleged, was done to deceive the trade and public in a way that permits unscrupulous dealers to deceive innocent purchasers and sell the defendants' goods for those of the complainants.

Going on still further, the complaint takes up the question of alleged misrepresentation by the salesmen of the defendants in regard to emphasizing the similarity of the goods of the latter with those of the complainants and shows that the actions of the defendants encourage others to imitate the design, printing matter, etc., of the Hold-On Clutch Co.

It is contended that the acts in question are inequitable and unfair, and that they constitute an invasion of the good will of the complainants' business, which has been damaged to the amount of \$100,000, and profits to the amount of \$20,000 at least have been diverted from them, and the amount of damages directly and indirectly caused will amount to more than \$40,000, for which they ask that the defendants be decreed to account for in full.

The complaint winds up by asking that the defendants be required to file an answer to the allegations and be enjoined and restrained, together with their agents, associates, workmen, etc., from manufacturing, using or selling any of the alleged infringements, or from further arranging of such devices on cards or advertising matter which would deceive the public or ordinary purchasers, and that they be prohibited from doing any act which will cause their goods to be mistaken in the market for those of the complainants.

The usual accounting of profits is asked for with damages of three times the amount that may be assessed, together with such other relief usual in a suit of this kind.

The answer to the complaint has not yet been filed.

John McCullough and Thomas Parmar were arrested in Wilmington, Del., about two weeks ago, having in their possession a box of lenses and a number of eyeglasses. The men were held in \$300 bail. A policeman who took the men in custody testified that he saw McCullough and Parmar on their hands and knees in front of the store of Jos. T. Montgomery, 229 Market St. One of the men, he said, appeared to be tampering with the lock in the door. J. H. Gordon, of the Gordon, Ries & Hirsch Co., identified the lenses and eyeglasses.

Jewelry, Clocks, Watches, Silverware and Kindred Lines Exported from New York.

WASHINGTON, D. C., March 25.—The following were the exports of jewelry, silverware, optical goods, clocks, watches and kindred lines from the Port of New York for the week just ended:

Barbados: 10 cases clocks, \$110.
 Berne: 1 case watch machinery, \$144.
 Bremen: 3 cases watches, \$1,795.
 Callao: 2 cases jewelry, \$300; 14 cases clocks, \$174.
 Calcutta: 21 cases clocks, \$385; 3 cases plated ware, \$230.
 Christiana: 16 cases clocks, \$222.
 Colon: 25 cases clocks, \$235; 1 case watches, \$147.
 Constantinople: 6 cases clocks, \$267; 8 cases clocks, \$100.
 Curacao: 17 cases plated ware, \$1,339.
 Demerara: 13 cases clocks, \$205.
 Dublin: 18 cases clocks, \$490.
 Genoa: 8 cases clocks, \$275.
 Hamburg: 7 cases optical goods, \$1,074.
 Havre: 2 cases watches, \$3,672; 1 case jewelry, \$140.
 Havana: 16 cases clocks, \$221.
 Hongkong: 87 cases clocks, \$1,243.
 Lagos: 7 cases clocks, \$113.
 Liverpool: 3 cases watches, \$1,500; 60 cases clocks, \$3,500.
 London: 2 cases plated ware, \$144; 5 cases jewelry, \$109; 63 cases clocks, \$1,297; 3 cases watches, \$170; 141 cases clocks, \$4,890; 5 cases optical goods, \$163; 5 cases optical goods, \$179; 1 case jewelry, \$500.
 Natal: 79 cases clocks, \$1,145.
 Para: 15 cases clocks, \$188; 1 case watches, \$155.
 Rangoon: 61 cases clocks, \$1,013.
 Santiago: 75 cases clocks, \$1,035.
 Shanghai: 52 cases clocks, \$904.
 Savanola: 1 case optical goods, \$135.
 Southampton: 23 cases watches, \$4,584.
 St. Johns: 20 cases clocks, \$342.
 Sydney: 4 cases optical goods, \$330.
 Trinidad: 6 cases watches, \$168.
 Valparaiso: 6 cases plated ware, \$545; 1 case watches, \$1,037; 9 cases clocks, \$135; 2 cases watches, \$195.
 Vera Cruz: 1 case optical goods, \$18; 38 cases clocks, \$495.

Tariff Decisions by General Appraisers on Jewelry and Kindred Lines.

Decisions by the Board of United States General Appraisers in cases involving duties on jewelry and kindred lines have been announced in the last week as follows:

COMBS—JEWELRY.—Protest of Stix, Baer & Fuller Dry Goods Co. (St. Louis). Opinion by Sharretts, G. A. Expensive and elaborate combs composed of celluloid and mounted with gold-plated metal set with imitation diamonds were held to have been properly classified as jewelry. G. A. 6658 (T. D. 28391) followed.

PINS—JEWELRY.—Protests of Scruggs, Vandervoort & Barney Dry Goods Co. (St. Louis). Opinion by Sharretts, G. A. The protests related to articles classified as jewelry or as decorated glassware. The assessment was affirmed except as to certain pins with plain heads, which the Board held dutiable as manufactures of glass under Par. 112, tariff act of 1897, as claimed by the importers.

JEWELRY.—Protest of D. B. Fisk & Co. (Chicago), protests of Abraham & Straus, protest of B. Altman & Co., protests of Libbey & Ryker, *et al.*, protest of Lippman, Spier & Hahn, protest of Isaacs, Vought & Co. (New York), and protest of Stix, Baer & Fuller Dry Goods Co. (St. Louis). The merchandise in question was held to have been properly classified as jewelry.

EDUARD VAN DAM

CUTTER OF

DIAMONDS

CUTTING SHOPS:

ANTWERP

41 Rue de la Province (Sud.)

CABLE ADDRESS, MADNAV

NEW YORK

437-439 Fifth Ave.
Cor. 39th St. Knabe Bldg.

TELEPHONE. 5879 38TH ST.
CABLE ADDRESS DEVRIVAN

AMSTERDAM

55 Ruysdaelstraat

CABLE ADDRESS. MADNAV

LONDON OFFICE, 22 Holborn Viaduct

AMSTERDAM
2 Tulpstraat

LONDON
40 Holborn Viaduct

OPPENHEIMER BROS. & VEITH.

CUTTERS OF DIAMONDS.

Cutting Works
43-45-47 John Street

NEW YORK
65 Nassau Street

R., L. & M. FRIEDLANDER

IMPORTERS OF

DIAMONDS

30 MAIDEN LANE, - - - NEW YORK CITY

MEYEROWITZ BROS

MEYEROWITZ BROS.

IMPORTERS OF

DIAMONDS

PRECIOUS and
SEMI-PRECIOUS STONES

ESTABLISHED 1896

NEW YORK: 37-39 Maiden Lane
PARIS: 58 rue de Maubeuge
AMSTERDAM: 2 Tulpstraat

MEYEROWITZ BROS

Commissioner Decides That Bankrupt Brooklyn Jeweler Robbed Himself and Orders Return of the Stolen Property.

As an outgrowth of an investigation instituted when a petition in involuntary bankruptcy was filed against S. Garfinckel, 713 Fulton St., Brooklyn, it has developed that the special commissioner appointed by the court to take testimony in the case has ordered that Garfinckel turn over to the trustees in bankruptcy all the assets that he had in his safe Dec. 14, 1907, which amounted in value to \$5,339 in jewels and \$600 in cash.

In December, 1907, Mr. Garfinckel reported to the police that thieves had gained entrance to his store and obtained between \$6,000 and \$7,000 worth of articles, such as watches, pins and a general assortment of jewelry and all that was left was about \$300 worth of cut glass. The matter was given into the hands of Acting Captain Kuhne, of Brooklyn police headquarters, and Detective Manning was assigned the case. At that time not a clue could be obtained, although all pawnshops were searched. The alleged robbery gave the police no end of trouble, and it now develops, according to the finding of the commissioner, that the proprietor of the store robbed himself in order to keep away from his creditors part of the stock.

Before the bankruptcy proceedings began against Garfinckel Max Sheinart, a lawyer at 320 Broadway, New York, attended to the legal business of the jeweler, but of late he has had nothing to do with him. One of the largest creditors is Lewis Phillips, Brooklyn, who, according to the testimony of Sheinart, had an interview with Mr. Garfinckel a short time before the robbery. Sheinart on the stand described a visit with Phillips to the jewelry shop, where they noticed that Garfinckel was moving out part of his stock. Phillips protested and Garfinckel, according to Sheinart, told Phillips that if he would advance another small loan he (Garfinckel) would repay him after he failed. Phillips then asked Garfinckel how he would account to his creditors for part of his stock being gone, and Garfinckel, said Mr. Sheinart, replied that it was the easiest thing in the world. "All that I have to do is to pack up this jewelry in a small satchel when I close up and walk out, and when I open next morning claim my store was robbed." When asked by Phillips if he did not consider that a rather risky proposition, Mr. Sheinart says Garfinckel replied, "Oh, it is all right; I will get an extension of one year, and when I begin business again nobody will be the wiser, and if they file a petition in bankruptcy against me they will get nothing. How will they be able to prove my stock was not robbed?"

Sheinart, who quoted Garfinckel's remarks at this interview also made a statement to the commissioner to the effect that Garfinckel told him that his stock was worth \$7,000 and that his liabilities were only \$1,700 or \$1,800. The story of the conversation was corroborated before Commissioner Morle by Phillips.

Six diamond rings which Garfinckel reported to the police as having been stolen from the safe were sold to him by Louis Shapiro, 14 John St., New York, and Mr. Shapiro testified that he had seen them, sub-

sequent to the robbery, in the possession of Mrs. Hannah Phillips, wife of Lewis Phillips. Several watches which Shapiro had sold Garfinckel, which were also reported stolen, were likewise in possession of Mrs. Phillips, according to Shapiro. There was also a diamond brooch, valued at \$175, which it was testified was pledged to Mrs. Phillips, for a loan subsequent to the robbery.

The decision of the commissioner is briefly stated in his opinion, which has been handed to Judge Charfield:

"Neither the testimony of the detective nor Mr. Shapiro having been denied, and the aim sought for by the bankrupt, that of having the store burglarized, being accomplished, and the fact that the jewelry which he said was in the safe at the time of the robbery being afterward found in the possession of Mrs. Phillips as security for a loan of \$750 is presumptive evidence of his being the man who committed the act."

The commissioner then orders that Garfinckel turn over to the trustee in bankruptcy all the jewelry that he had in his safe on Saturday, Dec. 14, amounting in value to \$5,339.65 in jewels and \$600 in cash.

Death of Geo. C. Schrieber.

LINCOLN, Ill., March 25.—George C. Schrieber, who died March 23, at his home in this city, after an attack of acute heart trouble, which followed an illness of several weeks, was well known to the jewelry trade, having conducted a jewelry and dry goods store in Lincoln for many years. Mr. Schrieber had been in poor health for some time, but his condition did not become at all serious until a few weeks ago.

Mr. Schrieber, who had followed the jewelry trade since early manhood, was a native of Germany and was born in Schmalkalden, June 29, 1839. He came of a family of watchmakers, his father and grandfather having been in the trade before him, and after learning all the details of his craft he came to this country and started first in Olean, N. Y., in 1860. After remaining there a year he went to Mitchell, Can., and from there, in 1865, went to Lockport, where he was associated with Henry Olin in the drug and jewelry business. The following year he went to St. Louis, Mo., and in June, 1867, came to Lincoln, where he immediately opened a jewelry store. He soon established a reputation as a practical watchmaker, and in the first two years made three watches. His business developed and in 1872 he built a store on Pulaske St., and later in addition to his jewelry business went into the clothing and dry goods line, moving to Broad St., where he was located for many years.

Mr. Schrieber was an exceptionally talented workman, and among the many things which he produced was a globe which brought him much fame. This globe, which was approximately six feet in diameter, was made and completed prior to the world's fair in Chicago and was shown at that exposition. The globe was an accurate representation of the earth's surface with properly scaled drawings. The work on it was marvously performed, much of the engraving and printing being done under a magnifying glass. The completed globe rep-

resented many years of skilled labor and a remarkable fidelity to accurateness and painstaking care, worthy of any genius.

The funeral services were held yesterday afternoon at the late home of the deceased on Ottawa and Tremont Sts.

Death of Benjamin Westervelt.

Benjamin Westervelt, one of the best known traveling salesmen in the watch trade, who was for about 25 years in the employ of the New England Watch Co., Waterbury, Conn., for whom he traveled in New York State and a part of New England, died at his home, Mt. Vernon, last Thursday, of apoplexy.

Mr. Westervelt suffered from appendicitis early this year and Jan. 30 he underwent an operation at the Mt. Vernon Hospital, from which he never completely recovered. He was brought back to his home March 18 and for a while showed improvement and his friends had hoped to soon



THE LATE BENJAMIN WESTERVELT.

see him at his work again. The news of his death, therefore, came as a distinct shock.

Mr. Westervelt was born 58 years ago in New York, but went to Mt. Vernon, N. Y., when four years of age and had lived in that city ever since.

He was a prominent member of the Commercial Travelers' Club of Mt. Vernon, of Hiawatha Lodge, No. 434, F. and A. M., of Mt. Vernon Chapter, No. 228, R. A. M., and of the Golden Rod Council, No. 1316, R. A. H.

Deceased was a man who formed a wide circle of friends and acquaintances during his many years on the road and was universally liked and respected for his many fine qualities both as man and salesman. He is survived by his widow, Sarah E., two sons, States and John Westervelt, a sister-in-law, Miss Clara A. Briggs, all of Mt. Vernon, and a younger brother, Frank Westervelt, of New Haven, Conn.

The funeral services were held Sunday afternoon from St. Paul's Church, Mt. Vernon.

Cameos=Scarabs=Carbuncles

Notwithstanding the difficulty generally experienced at present in supplying the sudden demand for these goods, we have succeeded, thanks to our firmly established connections with the stone centers of Europe, in making arrangements for the uninterrupted supply of them and are, therefore, fully prepared to fill all orders for these articles with the least delay.

CAMEOS

Onyx, Pink and Brown Shell, and Coral

SCARABS and CARBUNCLES

Red and Brown Sard, Bloodstone, Moss Agate, Green Agate, New Zealand and Chinese Jade, Amazonite, Tiger Eye, Coral—Japanese and Italian, and

TURQUOISE MATRIX

J. Heller & Son

Importers of Precious and Imitation Stones
68 NASSAU STREET, NEW YORK

PARIS
39 Rue de Chateaudun

PROVIDENCE
212 Union Street

IDAR
14 Hauptstrasse

ORDER

DIAMONDS

ON MEMORANDUM FROM

ALFRED H. SMITH & CO.

London,
6 Holborn Viaduct.

170 BROADWAY, NEW YORK.
Corner Maiden Lane.
Also 475 FIFTH AVENUE.

Chicago,
103 State Street.

TURQUOISE

Matrix-Turquoise
BEST THE WORLD PRODUCES

Exquisite Color
and Markings



No. 222

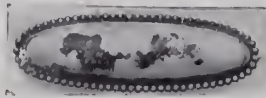

No. 316

SEND FOR CATALOG

Showing 133 different sizes and shapes
of MATRIX-TURQUOISE STONES
ready for Mounting.

The Arizona
Turquoise Mines Co. Inc.

Cutting Works and Sales Office:

171 BROADWAY, NEW YORK
Telephone 5728 Cortlandt

RUDOLPH NOEL

RUDOLPH NOEL & CO.

PHILIP NO

IMPORTERS AND CUTTERS OF DIAMONDS

2 Tulp Straat, AMSTERDAM

37-39 Maiden Lane, NEW YORK

Letters of Comment on the Proposed Watch Case Law Introduced by Congressman Vreeland.

CHICAGO, March 16, 1908.

Editor THE JEWELERS' CIRCULAR—WEEKLY:

We notice in your last issue reference to a law in regard to warranting of filled watch cases. We are in favor of any law which will have a tendency to prevent "fake" merchandising.

We should like incorporated in the bill a clause including jewelry; especially in plated chains, where there is just as much need for protection to the consumer as in cases. Tags are printed warranting chains for 10, 15 or 20 years and put on articles which will not wear a year. Many retail jewelers supposing they are getting a bargain buy these chains, giving notes, which are transferred to a third party, or pay cash. When the chains wear out in a short time they are unable to have the guarantees made good, as those from whom he bought them have assumed another name, so the guarantees are worthless.

Yours very truly,

LAPP & FLERSHEM.

GREENSBORO, N. C., March 17, 1908.

Editor THE JEWELERS' CIRCULAR—WEEKLY:

GENTLEMEN:—I have read the proposed watch case stamping law and have just written Mr. Vreeland that I am opposed to the law as it stands for the following reasons:

People have been acquainted with the present mode of selling filled cases, and if the manufacturer does not give any guarantee with them for any length of time for them to wear they would not buy them, and the retailer himself would be compelled to give a personal guarantee to sell them, which a national law could not prohibit, but which he could not afford to do.

Again the various factories could contract with the retailers to replace their cases within a certain time, without violating this law, and conditions would be practically as they are now and the law simply a dead letter.

Why not make the law so that a 20 or 25 year case must have a certain thickness of gold on the outside or inside of case, and the whole trouble about putting snide cases on the market would end.

One good thing the proposed act would accomplish, however, and that is it would decrease the sale of filled cases and increase the sale of gold ones, and perhaps drive the filled cases out of the market altogether. I found that in Germany filled cases cannot be sold as the people simply prefer a light, low karat gold case to the finest filled ones, though a good filled case is really preferable. Here the people prefer filled cases now, but they hardly would do so if they have to prove that the thickness of the gold is not as indicated on the case to hold the manufacturers responsible. It is impossible to prove that the manufacturer or retailer sold them a case of less thickness, "knowingly," so this provision in the bill makes any penalty impossible.

Trust you will publish my idea of this

matter and see what the rest of the retailers think about it.

Yours very truly,

R. C. BERNAU,
Treas. Amer. Nat'l Retail Jewelers' Assn.

VAN WERT, O., March 19, 1908.

Editor THE JEWELERS' CIRCULAR—WEEKLY:

Dear Sir—In regard to the bill regulating gold filled cases, I cannot see where we, the retail jewelers, will be benefited by such a measure. It will be a loophole for manufacturers to get out of guaranteeing cases, and the jeweler will be the loser, as the only taking feature we have in selling watch cases is the guarantee that goes with them; if manufacturers didn't guarantee the case to wear a certain length of time, how could we do so?

If all cases were stamped according to the bill introduced, the legitimate jeweler would be put out of business by mail order and dry goods houses using them for leaders, as the public could then trust these concerns as well as jewelers. The way it is now, these houses sell cheap plated cases and when they catch a farmer on them, the next time the latter or his friends want a case they go to a jeweler they can trust as one who sells reliable goods. It is the cheap cases and 10-year cases, guaranteed for 20 years by mail order houses that make these people go to legitimate jewelers. Trusting you will hear other reports on this subject, I remain,

Yours truly,

CHAS. J. SCHOLLER.

KEWANEE, Kans., March 16, 1908.

We cannot add anything more than our hearty approval to any law that will improve the existing condition of fraud imposed upon the public in misrepresenting the quality of watch cases and jewelry in general of whatsoever material they are composed of.

W. A. BOWEN.

PRESCOTT, Ark., March 23, 1908.

Editor THE JEWELERS' CIRCULAR—WEEKLY:

I am in receipt of a letter with a copy of Hon. Edward B. Vreeland's Watch Case Marking Act, and I want to say I think this bill would be the worst thing that could be enacted for the trade. Matters are right as they are now. To take the guarantee out of the case would mean a lot of hard work for us poor jewelers. I would as leave undertake to preach a sermon every time a customer comes in as to try to convince him that a case is guaranteed for 20 years if he could not see the fact before his eyes printed in the case. I have never had a factory to refuse to replace one of their cases when it showed any wear at all, and I think it will be a better thing to let the Congressman spend his time at making other laws that will do more good for the honest working people than to bother with laws that mix up the watch case trade and hurt the jeweler. I think the American National Retail Jewelers' Association can adjust any

trouble that would come up if any case factory falls short in its contract and refuses to do what it promised to do.

Every jeweler and every customer knows that a 20-year case is 10-kt. and a 25-year case is 14-kt., so what is the use in having any such law passed to give the jewelers more trouble. We have troubles enough as it is, so for mercy's sake don't make any more; we have it now by the peck, and I am sure we don't want it by the bushel.

Now, brother jewelers, let me hear from some of you and let me see what you think. I may be wrong, but stop and think how much hard talking you do now and then think how much you will have to do if this bill passes.

Yours respectfully,

E. A. SHORT,
Pres. Arkansas Retail Jewelers' Assn.

Death of Axel F. Anderson.

NEW LONDON, Conn., March 27.—Axel F. Anderson, for many years one of the most prominent jewelers of this place, died suddenly yesterday at 2 A. M. He had an attack of cerebral hemorrhage in his office on Wednesday afternoon. With his wife and daughter Mr. Anderson came to New London from their home in Waterford that afternoon, and the ladies, after completing a shopping tour, repaired to his office, only to find the door locked.

The daughter, upon looking through the keyhole, saw her father lying on the floor. Drs. G. S. Allyn and A. W. Nelson were summoned and the door was forced open. The door had a spring lock, and when Mr. Anderson shut the door it had evidently fastened itself. The physicians could not rally their patient from his comatose state, and he was taken to his home in Waterford, where he died without regaining consciousness.

Mr. Anderson was 67 years of age and a native of Sweden, having come to this country during the Civil War. His father was a successful contractor and builder. As a youth Mr. Anderson received a good education and then learned the watchmaker's trade, becoming an expert in the work. He worked at his trade in Hamburg, Berlin, Keil and other German cities before coming to this country.

After working for some time in New York, he came to New London in 1865, and for 17 years was employed by D. B. Hempstead, on Bank St. Then, in company with James Hustice, he purchased his employer's interest, and under the firm name of Hustice & Anderson successfully carried on the business for 12 years, at the same location. In 1894 he purchased Mr. Hustice's interest and continued the business for several years, after which, having become interested in real estate, he, six years ago, gave up his jewelry business to devote his whole attention to real estate, and died possessed of considerable wealth.

The deceased was an ex-grand officer of the Ancient Order of United Workmen and had enjoyed other high honors from that body. He was also a member of the Masonic fraternity and of the Second Congregational Church, in this city. He was highly esteemed by all who knew him. He leaves, besides his widow and daughter, two step-children.



RINGS



RINGS are always in demand, and are always salable, provided you have the right kind to sell. We have—

RINGS of every description: signet rings, diamond rings, fancy rings, rings of every style and combination of stones.

RINGS that satisfy the most critical and appeal to every taste and fancy.

RINGS You can sell. *Write us or wire us any time. We are always ready for your order.*

HAYDEN W. WHEELER & CO., Importers

AMSTERDAM, 2 Tulp Straat

2 Maiden Lane, NEW YORK, N. Y.
Phone, 7365 Cortlandt

LONDON, 50 Holborn Viaduct

F. A. JEANNE

ROUND AND FANCY-SHAPED SAPPHIRES

5 Square de l'Opera

PARIS, FRANCE

Cable Address

"GEMFINDER"

Western Union Code

Practical Course in Adjusting

By THEO. GRIDI.

COMPRISING

A review of the laws governing the motion of the balance and balance spring in watches and chronometers, and application of the principle deduced therefrom in the correction of variations of rate arising from want of isochronism, change of position and variation of temperature.

ELUCIDATED AND DEMONSTRATED

by original experimental researches in the actual problem, never before published, showing the causes that are operative in the variation of rate, and leading to correct remedies. It which have been added chapters on

Published Price, \$2.50.

SPECIAL REDUCED PRICE, \$1.50

Post prepaid.

250 pages, including 18 diagram plates; Fine Paper; Large Type; Clear Illustrations; Systematically arranged; Solid Binding.

THE JEWELERS' CIRCULAR PUB. CO.
Publishers

11 John St., cor. Broadway, New York.

STERN BROS. & CO.,

CUTTERS OF

DIAMONDS,

CUTTING WORKS:

138-142 West 14th St., N. Y.

68 Nassau St.,

NEW YORK.

CHICAGO,
103 State Street.

LONDON.
29 Ely Place.

EDELWEISS BROOCHES

CROSSMAN
COMPANY



\$10 DOLLARS
UP

3 Maiden Lane
NEW YORK

Cable Address: "LEOGOLDIE" N. Y.
Telephone, 4115 Cortlandt Amsterdam, 2 Tulp St.
Paris, 27 Rue Drouot

LEO. GOLDSMITH

IMPORTER OF
Diamonds and Precious Stones
9, 11 & 13 Maiden Lane, N. Y.

Diamonds, Rubies, Sapphires, Emeralds,
Opals, Olivines, Pearls, Half-Pearls, Tur-
quoises, Reconstructed Rubies, Recon-
structed Sapphires.

Death of Albert C. Wittnauer.

The jewelry trade both in this country and abroad learned last week with sorrow and regret of the death of Albert C. Wittnauer, president of the A. Wittnauer Co., Maiden Lane, New York, which occurred Wednesday, March 25, at Menton, South of France, where he had just gone from Geneva, Switzerland, to recuperate from an illness of some months' duration. Mrs. Wittnauer was with him at the time of his death. He left Geneva to seek relief and rest, and it was thought that he was improving. A sudden change for the worse ensued fatally, and while it was known at he was in poor health, yet his death came as a shock to his many friends and acquaintances throughout the country. Mr Wittnauer was a native of Switzerland, where he was born 52 years ago. He was from an early age identified with the



THE LATE ALBERT C. WITTAUER.

watch business, and when a young man came to America and began a career in New York in connection with this line that led him to become one of the pioneers in the Swiss watch industry in this country. From 1885 until 1890 he was a member of the firm of J. Eugene Robert & Co. He succeeded to the business of the firm in the next year, conducting it thereafter successfully under his own name. In 1904 he created a corporation which took over his interests in the New York and Montreal establishments, and has since largely resided in Geneva, Switzerland. There he made his headquarters, from which he successfully directed and superintended the factories which contributed to the large American business he had created. In later years Mr. Wittnauer branched out with other brands of fine watches, and made Agassiz, Touchon and Audemars, Guet & Co. watches famous throughout the trade. Mr. Wittnauer was one of the first to introduce American ideas and principles in the Swiss watch industry, and the magnifi-

cent success in this country of the Longines watches stand as an evidence of the conspicuous business ability of Mr. Wittnauer and his predecessor, Mr. Robert.

Deceased had a genial disposition and the faculty of making many friends both here and abroad, and nothing gave him more pleasure than to meet his American friends in Geneva or elsewhere in Europe, where he was noted for his hospitality. One of his favorite trips was to Carlsbad, where he usually went once a year, and where many of his friends in the trade will remember having met him. It was in Carlsbad that the picture published herewith was taken a few years ago.

Besides traveling, deceased was particularly fond of music, in which he was an expert critic. He was noted for his generosity, which was, however, unostentatious, and many will hold his goodness in grateful memory.

Deceased was a bachelor, and is survived by a brother and two sisters.

Short Change Swindler Gets Jewelry Worth \$1,150 from Chicago Dealer for \$19.

CHICAGO, March 28.—Anthony Sicilia, who conducts a branch jewelry store at 178 N. Halsted St. for Pasquale Schiavone & Son, was the victim last week of the flim-flammer against whom the Jewelers Security Alliance and THE CIRCULAR-WEEKLY have been warning the trade for some time. The stranger bought two 1½-carat eardrops and two two-carat rings for \$1,150. He said he wanted to show them, and in case he didn't want all the diamonds he was to have the privilege of returning what he didn't want to keep.

As a guarantee of good faith the stranger gave Sicilia a roll of bills amounting to \$1,119. Sicilia told him the amount was one dollar short. The stranger counted the roll again and said Sicilia was correct. Then he handed the supposed roll back to Sicilia and told him to put it in a drawer and to come with him and he would give him the extra dollar. The stranger then disappeared in the crowd, and when Sicilia went back to the store and counted the money he found it contained only \$19.

The same man tried to work the same game on a prominent W. Madison St. jeweler without success.

Jewelers' Gold Bars Withdrawn and Exchanged at New York.

Week Ended March 28, 1908.

The U. S. Assay Office reports:
Gold bars exchanged for gold coin.....\$209,180.00
Gold bars paid depositors..... 36,361.81

Total	\$245,541.81
Of this the gold bars exchanged for gold coin are reported as follows:	
March 23.....	\$21,128.43
" 24.....	27,914.28
" 25.....	56,074.77
" 26.....	35,484.67
" 27.....	52,988.79
" 28.....	15,589.06

E. E. Wheeler, Cando, N. Dak., expects to move his stock to a store in the post-office block about April 5.

The new store of Cohen Bros., at the corner of S. George and King Sts., York City, Pa., was opened for business Saturday, March 28.

Association Notes.

What Is Being Done by the State Organizations of the Retail Jewelers.

The annual meeting of the Oklahoma Retail Jewelers' Association will be held in Oklahoma City, April 21 and 22. The Oklahoma Optical Society will hold its meeting April 23 and 24 in the same place.

The following are the standing committees, appointed by Pres. J. R. Stebbins, of Ohio Retail Jewelers' Association: Trade Interests and Legislation—Frank Ausman, St. Mary's; Robt. Frizens, Cincinnati; C. J. Scholler, Van Wert. Qualities and Assays—Frank Deinlein, Columbus; F. J. Kemple, Ashtabula; W. R. Johnston, Butler. Membership and Deceased Members—John Bertling, Cincinnati; B. F. Philips, Akron; Webb T. Eby, Dayton.

Chairman Stebbins, of the membership committee of the National Association, is already in touch with his fellow committeemen and a good comprehensive, interesting report may be expected at the next National convention, to be held at Cincinnati, in August.

The Maryland Retail Jewelers' Association recently took action upon the false and unfounded stories published in the Baltimore newspapers in regard to the diamond trade and through their officers, particularly the secretary, F. J. Euler, succeeded in having these stories contradicted. As a result of their work the *Baltimore American*, among others, published a column article headed "No Lowering of Diamond Prices," which contained a statement of the true facts in regard to the diamond market, at the present time, and also a quotation of THE CIRCULAR-WEEKLY'S editorial of March 18, with interviews of various prominent Baltimore jewelers. The article also gave the names of the officers of the Maryland Retail Jewelers' Association. The organization has been warmly congratulated by the members and non-members alike in the work that has been done along this line.

The annual meeting of the St. Louis Retail Jewelers' Association was held in the library of the Jefferson Hotel, St. Louis, Mo., last evening (March 31), at 8 p. m. Among the matters of interest that were brought up for consideration were the proposed amendment to the National Stamping Law, the proposed national law for stamping gold-filled cases, the Watch Inspection Bill, the coming State convention, the national convention and election of officers.

A joint meeting of the executive officers of the Missouri Society of Retail Jewelers and the Missouri Association of Opticians was held March 23 at the Baltimore Hotel, Kansas City, and that city was selected as the place for the annual convention of these societies, which will be held June 9, 10 and 11. An effort is being made by these societies to organize a Kansas City Retail Jewelers' Association, and it is believed that this will have been accomplished by the time of the convention.

Chester Billings & Son

1840

Successors to
Kandel, Barmore & Billings

1908

Importers of Diamonds
Other Precious Stones, and
Pearls, Diamond Jewelry

1840, Kandel & Barmore; 1866, Kandel, Barmore & Co.; 1880, Kandel, Barmore & Billings; 1897, Chester Billings & Son

New York, 58 Nassau Street, 29 Maiden Lane
London: 22 Holborn Viaduct, E. C. Paris: 53 Rue de Chateaubain
Amsterdam: 2 Tulip Straat

GEORGE H. HODENPYL.

WALTER N. WALKER.

HODENPYL & WALKER

IMPORTERS OF

DIAMONDS

OTHER PRECIOUS STONES
AND PEARLSMANUFACTURERS OF
FINE DIAMOND JEWELRY

373 FIFTH AVENUE, NEW YORK

Corner 35th Street

Telephone, 5093 Madison Square

CHAS. F. WOOD & CO. DIAMONDS

1 MAIDEN LANE

NEW YORK

EISENMANN BROS.

IMPORTERS OF

Pearls and Precious Stones

452 Fifth Avenue, New York
cor. 40th St., Knox Building

3 Rue St. Georges, Paris.

CENTENNIAL TIMERS



Without question the best plain and split second timers made.

Register with scientific precision. Substantially built and mechanically perfect.

Invaluable for athletic, mechanical and scientific observations. Cased in nickel. Much in demand during the racing season.

We also carry split chronographs with minute registers, cased in gold, gold filled and sterling silver.

All makes of American cases and movements.



Cross & Beguelin

31 Maiden Lane, N. Y.

Established
1863Telephone
480 John

Examination in Bankruptcy Proceedings Against Kleinschmidt, Howland & Co., at New York.

An examination in the proceedings against Kleinschmidt, Howland & Co., 170 Broadway, N. Y., against whom a petition in involuntary bankruptcy was filed some time ago, was held before Commissioner Alexander in the United States District Court, Monday afternoon.

David C. Townsend of the firm of David C. Townsend & Co., was placed on the stand and examined relative to business transactions in 1907 with the firm of Kleinschmidt, Howland & Co. He testified that they owed him about \$70,000 and that he was not satisfied with Mr. Kleinschmidt's physical and mental condition, and that when he returned from Europe he considered Mr. Kleinschmidt a sick man and, wishing to protect himself he bought the entire amount of his account from the debtors in gems and put them in his stock. He received a receipted bill and also agreed to meet Mr. Kleinschmidt's notes as they came due. He said the goods were not worth more than he paid for them and that the transaction was an absolute sale.

Mr. Townsend stated further that about \$20,000 of goods were resold to Kleinschmidt, Howland & Co. The goods consisted of pearl necklaces. Considerable other testimony was taken relative to the transaction.

At a previous examination Mr. Kleinschmidt was placed on the stand and shown a paper dated Jan. 1, 1907. He was asked if he signed it, and he replied that he did. The paper was a statement of assets and liabilities of the firm Jan. 1, 1907. The assets were then put at \$338,381 and the liabilities at \$238,596, leaving a surplus of \$99,784. He was questioned as to what became of this surplus, and said that about \$60,000 of the surplus was gone, for, according to the books a surplus of \$39,784 remained Jan. 1, 1908.

Mr. Kleinschmidt was questioned as to what he actually knew the assets to be on Jan. 1, 1908, and he named over real estate, bills receivable, etc. He also gave testimony relative to a loan from Eichberg & Co.

Frederick W. Ehrard, formerly a partner of the concern, was examined at the first hearing. He said he ceased to be a partner three years ago, last January and that later he was a bookkeeper for the concern. He said he kept the books from Feb. 1, 1907, until the failure of the firm. He was questioned about several accounts which appear on the books of the concern, among which was that of James Foster & Son, London.

The witness testified in regard to dealings with David C. Townsend & Co.—an agreement account he called it. Asked what he meant, he explained that David Townsend & Co. took over from Kleinschmidt, Howland & Co. \$71,621 of merchandise, consisting of pearls, etc., for which they agreed to pay at maturity all of Kleinschmidt, Howland & Co.'s acceptances both here and abroad. He said that Townsend & Co. bought back of this amount \$19,000 worth of the goods. The examination of Mr. Kleinschmidt will continue Friday and that of Mr. Townsend on Monday of next week.

Imports of Clocks, Watches, Jewelry and Gems Into Canada.

TORONTO, Can., March 27.—The monthly report of the Department of Trade and Commerce of Canada for December, 1907, gives the value of imports for home consumption in the jewelry and kindred trades as follows:

	Month of December,		Nine months ending December,	
	1906.	1907.	1906.	1907.
Clocks:				
Great Britain.....	\$1,007	\$1,339	\$11,619	\$14,421
United States.....	19,280	21,651	217,233	225,059
Germany.....	718	1,042	33,388	40,023
Other countries.....	322	269	11,972	13,106
Totals	\$21,327	\$24,301	\$274,212	\$292,609
Watches:				
Great Britain.....	\$1,615	\$1,411	\$20,481	\$18,404
United States.....	63,088	42,050	573,590	605,659
France.....	303	355	18,282	3,856
Switzerland.....	11,520	20,624	118,976	167,114
Other countries.....	4,485	3,452	30,712	38,970
Totals	\$81,011	\$67,892	\$762,041	\$834,003
Jewelry:				
Great Britain.....	\$6,696	\$14,220	\$119,619	\$176,582
United States.....	57,128	39,747	603,110	588,218
Germany.....	4,921	6,600	82,869	91,522
Other countries.....	3,598	8,400	31,668	81,678
Totals	\$72,343	\$68,967	\$837,266	\$938,000
Gold and silver and manufactures of:				
Great Britain.....	\$11,092	\$18,304	\$194,933	\$197,823
United States.....	31,318	26,799	243,562	234,120
Other countries.....	1,654	4,351	58,276	51,170
Totals	\$44,064	\$49,454	\$496,771	\$483,113
Precious stones of all kinds and imitations of (dutiable):				
Great Britain.....	\$13,918	\$2,294	\$35,333	\$60,679
United States.....	8,963	799	37,481	55,032
France.....	1,091	1,376	22,929	61,400
Holland.....	676
Other countries.....	99,869	517	107,761	31,441
Totals	\$123,841	\$4,086	\$203,504	\$209,228
Precious stones of all kinds and imitations of (free):				
Great Britain.....	\$9,342	\$486,407	\$564,947
United States.....	\$5,921	4,828	108,872	193,307
France.....	5,557	122,714	263,978
Holland.....	20,751	218,694	310,299
Other countries.....	200	4,940	130,110	41,419
Totals	\$6,121	\$45,418	\$1,066,797	\$1,873,950

A. L. Blackmer Co., Inc., New Bedford, Mass., Makes an Assignment.

NEW BEDFORD, March 28.—The A. L. Blackmer Co., Inc., manufacturing cut glass, has made an assignment for the benefit of its creditors to George S. Honer, Eliot D. Stetson and Mahew R. Hitch, all of this city, who now have charge of the business. The reason of the assignment is poor business, inability to extend credit and keen competition in the glass cutting trade.

The amount of the obligations is not stated, but the debts are confined principally to the Merchants' National Bank of this city, David L. Parker and wholesale dealers in glass blanks.

The business was established by A. L. Blackmer about 18 years ago, and was incorporated in 1895 with a capital of \$50,000. The last financial statement shows liabilities, in addition to the capital stock, of \$41,590 bills payable, and \$12,991 accounts payable. The company owns three buildings on Second St., the property being valued at \$20,375; machinery worth \$14,635; merchandise \$21,449, and cash and accounts receivable \$19,717.

A. C. Zimmer, Plymouth, Ind., has purchased the stock of Theodore Wolff, Norway, Mich., and will continue the business.

Importations at the Port of New York.

Weeks Ended March 23, 1907, and March 21, 1908.

	1907.	1908.
China, Glass and Earthen Ware:		
China.....	\$85,727	\$42,946
Earthen ware.....	24,442	12,844
Glass ware.....	35,388	24,611
Optical glass.....	4,649	6,903
Instruments:		
Musical.....	25,894	15,484
Optical.....	9,938	5,037
Philosophical.....	2,158	5,101
Jewelry, etc.:		
Jewelry.....	25,183	8,385
Precious stones.....	958,815	102,303
Watches.....	30,636	15,246
Metals, etc.:		
Bronzes.....	13,174	1,287
Cutlery.....	53,675	27,442
Dutch metal.....	2,970
Platina.....	114,912	16,843
Plated ware.....
Silverware.....	1,092	2,105
Miscellaneous:		
Alabaster ornaments.....	556	8
Amber.....	17,536	5,166
Beads.....	8,640	2,564
Clocks.....	6,118	2,830
Fans.....	13,165	8,315
Fancy goods.....	19,239	7,392
Ivory.....	77,023	28,221
Ivory, manufactures of..	307	742
Marble, manufactures of.	56,833	36,982
Statuary.....	8,623	4,701

W. H. Replogle, Shenandoah, Ia., is now located in newly furnished quarters where he has better facilities for his increasing business.

ADDISON W. WOODHULL, President.
FRANK K. HUFF, Vice-President.

GILBERT T. WOODHULL, Treasurer.
WILLIAM J. McQUILLIN, Secretary.

MOUNT & WOODHULL,

IMPORTERS OF

DIAMONDS,

OTHER PRECIOUS STONES,

PEARLS, ETC.

MAKERS OF

FINE
DIAMOND
JEWELRY.

26 Maiden Lane,

(Southwest Corner Nassau Street)

NEW YORK

EMERALDS, DIAMONDS
AND PEARLS

CABLE ADDRESS:
MILBAGG

BAGG & CO.
Successors to BAGG, PERINE & CO.
IMPORTERS
452 FIFTH AVENUE, at 40th Street
NEW YORK

TELEPHONE
NUMBERS:
917-918 BRYANT

RUBIES AND
SAPPHIRES

HIRSCH & HYMAN,

IMPORTERS AND CUTTERS OF



2 MAIDEN LANE, NEW YORK

Broadway-Maiden Lane Building

TRY
US ON

Lissauer & Company
IMPORTERS

DIAMONDS

52-54 MAIDEN LANE, NEW YORK

A. ROSEMAN, 9-11-13 Maiden Lane, New York

IMPORTER OF

DIAMONDS

Maker of Diamond Jewelry

A
TRADE-MARK.

Established 1872
HEADQUARTERS FOR
**AMERICAN
WATCHES**

Death of Oscar F. Eisenmann.

A cablegram received in New York Monday announced the sudden death at Paris of Oscar F. Eisenmann, of the firm of Eisenmann Bros., importers of pearls and precious stones, 452 Fifth Ave. The message stated that as Mr. Eisenmann was returning to his home in Paris with his family after attending church he felt a pain in his heart and died a short time thereafter.

Mr. Eisenmann, who was one of the most prominent men in the American and European gem trade, was born in Stuttgart, Germany, June 10, 1845. After coming to this country at an early age he and an elder brother, Emile, were employed by Jacques Schieb, a diamond and precious



THE LATE OSCAR F. EISENMANN.

stone importer, 22 Maiden Lane. The two brothers succeeded to the business and late Gustav Eisenmann, a third brother, came to New York, and Oscar went to Paris where he has since lived, to look after the branch in that city.

Deceased is survived by a widow, two married daughters and two brothers, of whom Gustav is at the New York branch. The funeral will be held to-day from Mr. Eisenmann's late home in Paris.

Chas. D. Tucker, Medford, Mass.,
Voluntary Bankrupt.

Boston, Mass., March 28.—Charles I. Tucker, a jeweler of Medford, has filed voluntary petition in bankruptcy, his schedules showing liabilities of \$5,738 and assets of \$1,771. The only secured creditor named is the Medford Savings Bank, with a claim of \$1,900. The principal unsecured creditors are Edward W. Mitchell, Medford \$2,932; Cyrus A. Noyes, Cambridge, \$13; E. T. Bigelow, Medford, \$150.

Mr. Tucker commenced business in Medford in 1891, succeeding E. W. Mitchell. He was employed by Nelson A. Brown & Palmer, Bachelder & Co. before going in business for himself. He has been well thought of in the trade and has had but few creditors, his principal merchandise accounts being in Boston.

Creditors of B. Kahn & Bros., Baltimore, Meet in New York and Reject Offer of Settlement.

A meeting of the creditors of B. Kahn & Bros., Baltimore, Md., was held at the Astor House, New York, Friday, at which time the debtors' attorney told how an involuntary petition in bankruptcy had been filed against the concern by a brother-in-law and other creditors. The attorney said that the brother-in-law claimed that the conditions of the business from time to time had been misrepresented to him and that he was interested through indorsements and loans to the amount of about \$10,000, and that this step was taken to protect his interests.

According to the statements the assets were about \$24,888 and the liabilities \$47,000. An offer of settlement was made, based on the following: 12½ per cent. to be paid in cash and 12½ per cent. in six months on indorsed notes. After considerable discussion the creditors voted to reject the offer unless a better proposition be made to insist that the matter be put through bankruptcy.

It was the general opinion of the creditors present that the appraisal did not show the debtors' true condition. A committee, consisting of Sol. Freudenheim, Louis Gray and David Mayer, was elected to go to Baltimore and look over the debtors' stock and examine their books; the expenses of the trip to be borne pro rata by the creditors present or represented at the meeting. The attention of the attorney for the creditors was called to a written statement made by the debtors, under date of March 5, in which they claim \$54,147 in assets and liabilities of but \$38,359.

Cultivation of Mexican Pearls Carried on in Lower California.

CONSUL W. D. SHAUGHNESSY, of Aguascalientes, transmits an article from the Mexican *Herald*, of Feb. 16, 1908, wherein it is claimed that the honor of being first to discover and put into successful operation the secret of cultivating pearls belongs to a Mexican company. The following paragraphs are taken from this article:

Under the old system the pearl industry was an uncertain one. Bushels of shells might yield but a few gems or possibly none at all. But this company, which is working under a concession from the Mexican Government, has taken up the cultivation of pearls as a practical industry, and is now operating the largest pearl farm in the world, employing in the harvesting season more than 1,000 people. They are operating in the Gulf of Lower California. The present markets for the company's products are Paris, London and Berlin, and Hamburg and Bremen for the mother-of-pearl, which is exported in large quantities.

Two years are required for the growth of an ordinary shell, which forms slowly in layers, like an onion. After two years the shell loses its gem, and, unless opened at the proper time, there is nothing of value within. Mr. Vives, who spent 25 years in studying and experimenting, discovered his fact, and thereupon he devised the system whereby the shells are cultivated until the proper time and then opened.

In the first place, the shells are gathered in the season when the eggs are being deposited. These eggs are carefully placed in little artificial channels like the natural bottom of the sea, care being taken in these channels to protect the little "animals" from their natural enemies. At the proper stage they are transplanted into deeper water, where a series of boxes continue to protect them. The stock is also inspected and the "dead" ones removed and

replaced by "live" shells. In the deeper channels the shells are left to develop, and at the end of two years the harvest is ready. In the deep-water cages, where the pearls develop, the divers can descend without risk.

Three distinct kinds of pearls are produced in the California Gulf, the most valuable being black pearls. The next in point of value are the white pearls, the price varying with the size and perfection of the gem. The yellowish pearl, although ranking third in value, is, as a rule, first in favor among the feminine admirers because of the brilliancy of the gems.

Death of Emerson Tyrell.

DETROIT, Mich., March 28.—Word has been received here of the death of Emerson Tyrell, the oldest jeweler of Green Bay, Wis. Mr. Tyrell was stricken with paraly-

Beautiful Silver Loving Cup Presented to Oscar Hammerstein.

Saturday night at the evening performance at the Manhattan Grand Opera House, New York, the beautiful silver loving cup illustrated herewith was presented to Oscar Hammerstein by the members of the Manhattan Grand Opera Co.

The cup is a clever production of the silversmith's art, and reflects much credit on its makers, Reed & Barton, Taunton and New York. It is gracefully shaped and embellished with artistic applied decoration. The base has a scalloped effect, and rising from this are the figures of two mermaids



BEAUTIFUL SILVER LOVING CUP PRESENTED TO OSCAR HAMMERSTEIN.

sis last November and was forced to retire from business. He was a prominent member of the Masonic fraternity and also well known in the jewelry trade.

The deceased, who was 63 years old at the time of his death, was noted for his practical ability as a jeweler. He conducted a repair business for many years on his own account, but from 1896 until his death he was connected with Adolf Michael.

James Wetzel, alias J. K. Hoover, alias R. F. Miller, was arrested about a week ago in Norristown, Pa., charged with scheming to defraud a number of business men of that section. He represented himself as the trustee of a tribe of Redmen and called upon Frederick Richter, a jeweler, placing with him an order for 62 gold badges. He placed a similar order with James B. Ray, another jeweler.

on opposite sides, holding in outstretched hands daintily wrought wreaths of laurel. The figures join the body of the loving cup near the top, thus forming the two handles.

On one side is an artistic shield representing music, and about the shield is a garland. The shield shows two female figures, before whom is a cherub, half kneeling. In the background is the Manhattan Grand Opera House. The shield is suggestive of music. It was made by G. Fiaccarini.

On the opposite side is the following inscription: "To our beloved impresario, Oscar Hammerstein, a token of sincere appreciation of his splendid services in the cause of art and his constant sympathetic interest in his artists. From the members of the Manhattan Grand Opera Co., season of 1907-8. New York, March 28, 1908."

WM. S. HEDGES & CO.,

IMPORTERS AND CUTTERS OF

DIAMONDS.

Precious Stones and Pearls.

170 Broadway, Corner Maiden Lane, New York.

27 Holborn Viaduct, London.

SAPPHIRES

SAUNDERS, MEURER & Co.

65 NASSAU STREET

NEW YORK

Goodfriend Bros.
IMPORTERS OF **PEARLS**

Sapphires
Rubies
Opals
Emeralds

Aquamarines
Peridot
Gem Coral
Tourmalines

AGATE, EMERALD, RUBY, SAPPHIRE, TURQUOISE, MOONSTONE, SPINEL, OPAL, CATSEYE, JACINTH, OLIVINE, BERYL, KYACINTH, GARNET, ESSONITE, PERIDOTS, TOURMALINE, PEARL, ALMANDINE, METEORITE.

Copyright, 1893 by GOODFRIEND BROS.

and OTHER
Precious and Imitation Stones

PEARL-OPAL-CORAL & AGATE NECKLACES

PARIS: 10 Rue Cadet.
PROVIDENCE: 212 Union St.

9-11-13
**Maiden Lane
NEW YORK**

Geo. Brunswick, N.Y.

Harrisburg, Pa.

H. F. Eyer has improved the interior of his Chambersburg jewelry store.

E. S. Loy, New Bloomfield, is preparing to erect a new residence in that town.

Permanent organization of the West Fairview Board of Trade was effected March 26.

John E. Fissel has sold his store in Boiling Springs to John E. Ward, who takes possession April 9.

Tausig Bros. will shortly have their remodeled property at 2d and Walnut Sts. ready for occupancy.

E. L. Rinckenbach and G. A. Hutman will shortly prepare their Summer cottages at Mt. Gretna for occupancy.

C. Ross Boas is showing his friends an autograph photograph recently received from Secretary of War W. H. Taft.

The amount necessary for the installation of a large town clock in the new Cumberland Methodist Church has practically been secured.

Jewelers of N. 3d St. were unsuccessful in their efforts to persuade City Councils to require the local trolley company to run cars both ways on that thoroughfare.

The Bailey, Banks & Biddle Co., of Philadelphia, has made return to the State Department of an increase of capital stock from \$800,000 to \$1,000,000, the additional issue of \$200,000 being preferred stock calling for 7 per cent. annual accumulative dividends, and may be redeemed by coupon at par and 10 per cent. premium any time within five years from March 1, 1908. The chief stockholders are: Jos. T. Bailey, 2,270 shares; Chas. W. Bailey, 1,169 shares; Geo. W. Banks, 1,000 shares; Anne M. Walker, 500 shares; estate of T. M. Drysdale, 690 shares, and Clement Weavel, 335 shares.

Samuel Green, aged 23, who was arrested in this city charged with complicity in the robbery of the store of Shapiro Bros. at Orbisonia, this State, of about \$600 worth of watches, silks, etc., was taken to that place by Chief of Police Cuthbert. Greer was apprehended at the Union Station while trying to sell one of the 10 gold watches to a fellow traveler. He denied taking any part in the burglary, but admitted seeing stranger raise a window and enter the store.

Achie K. May, the York jeweler whose window was broken and a lot of ring stolen therefrom, last week made a demand that Constable Cookes return to him within an hour four rings which Cookes secured from Mr. May's clerk, Eddie Link for the alleged purpose of using in his proposed rounding up of the men who stole them from the store. His future action in case the rings are not returned has not yet been decided upon. David Seager, of Pleasureville, who was arrested, March 2 at York, on the charge of stealing eight hams, was served with a warrant charging him with being one of the three persons who robbed May's jewelry store. The prisoner was brought before Alderman M. and held under \$1,000 bail. Detective White paid a visit to the Seager home and secured four rings, three of which bore the jeweler's cost marks. Four rings were also found at the Seager home by Detective Stroman and Cookes, all of which bore cost marks of the jeweler.

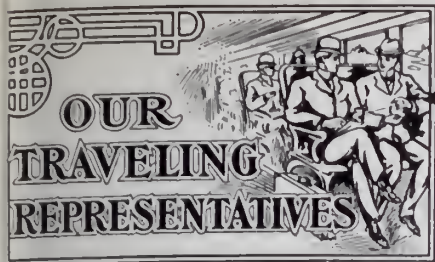

Chas. E. Hancock, of the Chas. E. Hancock Co., is now in San Francisco, Cal.

Traveling representatives in Los Angeles, Cal., recently, included: F. H. Wilkinson, A. Wittauer Co.; Mr. Coles, Tuthill Cut Glass Co.

The following traveling representatives called in the trade in Kansas City, Mo., last week: William Matschke, A. Joralemon & Son; L. E. Fay.

H. A. Forbes, Pacific coast representative of the Dueber-Hampden Watch Works, has just left his San Francisco offices for a long trip through the northwest.

Traveling representatives in Denver, Colo., recently, included: J. A. Patterson, Hayden W. Wheeler & Co.; Ben Spier, Spier & Co.; Gus T. Weil, Electric City Box Co.

Among the traveling representatives in Toronto, Ont., last week, were: R. H. Howe, Wagner-Gerstley Co. (London, Eng.); Mr. Delfosse, Pairpoint Corporation; L. M. Kronheimer, Kronheimer & Oldenbusch Co.; Fred Strauss, Backes & Strauss.

The following traveling representatives were in Savannah, Ga., recently: J. Zineman, Heyman & Kramer; George H. Wright, Unger Bros.; Fred Casper, Mauser Mfg. Co.; George T. Howard Towle Mfg. Co.; J. T. Garrett, Hayden W. Wheeler & Co.; Arthur Rosenberg, Alling & Co.

Among the traveling representatives visiting the trade in Lancaster, Pa., recently, were: M. F. Thornton, A. J. Hedges & Co.; S. A. Lynch, Wm. B. Kerr Co.; O. J. Sommers; John H. Baker, Jacobson Bros.; Walter S. Strauss, Jacob Strauss & Sons; Leon K. Beidler, B. F. Williams Co.; J. J. Doll, Keller Jewelry Mfg. Co.

The following traveling representatives were in Cleveland, O., last week: R. Schley, Sloan & Co.; C. F. Hartshorne, Kremenz & Co.; J. F. Schierloch, Keystone Watch Case Co.; H. Bliss, Wordley, Allsopp & Bliss Co.; S. E. Bolles, Wm. Scheer; Mr. Sherrill, Sinnock & Sherrill; Mr. Ryder, W. E. Hayward & Co.; L. Smith, Bippart, Griscom & Osborn; Mr. McClannin, Wilcox Silver Plate Co.; Mr. Loeb, Dueber-Hampden Companies.

The following traveling representatives were in Omaha, Nebr., last week: Mr. Mendoza, Van Dusen & Stokes Co.; Charles H. Ide, Farrington Mfg. Co.; Frank A. Rydstrom, E. Howard Watch Co.; H. Jacobson, Jacobson Bros.; S. H. Lesser, Manhattan Silver Plate Co.; Alfred H. Baer, Atleboro Chain Co.; Thomas H. Batcheller, Moore & Son; Theo. M. Schroeder, Schieckerling Mfg. Co.; E. Cohn, Cohn & Rosenberger; W. S. Willis, Gorham Co.; E. E. Spaulding, Allsopp Bros.; Harry Godison, E. G. Webster & Son; George Taylor, Wilcox & Wagoner Co.; A. M. Breckenridge, Benj. Allen & Co.; W. F. Adams, Simpson, Hall, Miller & Co.; J. M. Curtis, International Silver Co.

Traveling men visiting Boston, Mass., during the week, included: Austin M. Hill, Jr., Hill & Schmidt; Mr. Allsopp, Wordley, Allsopp & Bliss Co.; Paul H. Phelps, Enos Richardson & Co.; D. Tomkins, Mabie, Todd & Co.; W. H. Thornton, Henry A. Kirby; E. W. Martin, Martin-Copeland Co.; George W. Read, Larter & Sons; Charles T. Dougherty, Osmer-Dougherty Co.; Henry C. Ward, Durand & Co.; Frank Jeanne, William S. Hedges & Co.; V. S. Chapman, Osman-Parker Mfg. Co.; C. H. Crane, Strobell & Crane; Samuel L. Howland, Joseph Frankel's Sons; Frank L. Wood, Ludwig Nissen & Co.; E. H. Cox, Sussfeld, Lorsch & Co.; George H. Sylvia, Pairpoint Corporation; Arthur Cope, Rogers, Smith & Co.; Fred Rustin, Osgood & Son.

Traveling representatives who called on the Cincinnati, O., trade, during the past week, included: R. H. Cragin, Oneida Community, Ltd.; F. W. Hall, Irons & Russell Co.; Mr. Gaw, Standard Button Co.; Frank J. Ryder, Walter E. Hayward; W. C. Barry, Larter & Sons; J. E. Simonson, Ludwig Nissen & Co.; C. B. Bartlett, Whiting Mfg. Co.; Thomas E. Rogers, Riker Bros.; John H. Baker, Jacobson Bros.; Leo Henle, Sussfeld, Lorsch & Co.; H. W. Raymond, Worthington & Raymond;

O. Krause, Arthur W. Ware & Co.; R. W. Sawyer, Shafer & Douglas; C. H. Davison, Kahn & Co.; S. C. Corbin, Waterbury Clock Co.; G. W. Bleecker, Martin-Copeland Co.; George S. Melville, D. Wilcox & Co.; Mr. Hubley, Geo. Borgfeldt & Co.; R. L. Morehead, R. L. Morehead & Co.

News Gleanings.

The Midland Mfg. Co., dealing in jewelry specialties, has moved into the Brandeis building, Omaha, Nebr.

B. O'Connor & Sons, Mapleton, Pa., have sold their store to I. W. Fleck, who has just taken possession.

The chattel mortgage on the stock of J. W. Beverly, South Berwick, Me., was discharged, March 27.

The store of Stanley Wildren, a dealer in jewelry and crockery, Middleville, Mich., was destroyed by fire March 25.

Damage amounting to \$30,000 was done by fire to the jewelry establishment of A. Rosenthal & Sons, Ottawa, Ont., Thursday, March 26.

Frank S. Fisher, 12 W. Main St., Danville, Ill., has leased the store at 10 N. Vermilion St., which will be entirely remodeled for his use.

M. Barnes, Oto, Ia., a jeweler and stationer, on Wednesday, March 25, sustained a loss of \$1,500 by fire. The loss is partly covered by insurance.

S. E. Theus, Savannah, Ga., is chairman of the banquet committee of the Savannah Board of Trade, the silver anniversary of which will be celebrated April 3 with a banquet at the De Soto Hotel.

An attractively designed street clock has just been erected in front of the establishment of the Frank Schlamp Co., Des Moines, Ia., at the corner of 6th and Locust Sts. The clock was made by the Seth Thomas Clock Co.

George A. Logan, Sr., who has been for many years employed as clock repairer by the New York Central Railroad, died at his home in West Albany recently of paralysis. Mr. Logan had been connected with the Central road for 40 years.

An Assyrian jewelry vender named Joseph Vorco, Smithton, Pa., was recently waylaid in Weston by three white men and a negro, who robbed him of his stock and \$5 in cash. After he was assaulted passersby found him prostrate and helpless. His injuries are not serious.

A new cut glass plant was placed in operation at Bowling Green, O., recently, by Pitkin & Brooks, the firm closing their plant at Chicago Heights. The firm, which originally was at Bowling Green, moved its molds, etc., to Jeannette, Pa., where a new plant has been started in connection with the McKnee-Jeannette interests.

John E. Bong, a jeweler at Corning, N. Y., is the plaintiff in a peculiar law suit. Mr. Bong secured a judgment against Charles Smith, and then procured his arrest on contempt proceedings under supplementary proceedings. Smith was arrested, but the Sheriff allows him to go anywhere he desires in Bath, where the county jail is located. Bong has now sued the Sheriff for releasing Smith from custody.

The first meeting of the creditors of the G. W. Drake Cut Glass Co., Corning, N.

Y., was held at the office of Darrin & Darrin, March 20, and F. C. Williams and T. F. Rogers were appointed joint trustees in the bankruptcy proceedings. The liabilities are about \$80,000. The value of the assets have not been made public, but appraisers have been appointed. The trustees were authorized to advertise the stock and equipment for sale, April 3.

The store of Abraham Shapiro, Scranton, Pa., was broken into early Tuesday morning of last week by thieves, who made off with about \$500 worth of stock. Stanley Pankalaski and Jacob and Frank Dombeck, all youths between 16 and 17 years of age, were shortly afterwards taken into custody, accused of the crime. The first two named confessed, but the last one denied all connection with the burglary. The stolen jewelry was found in a telephone box.

The Iowa State Association of Opticians and the Iowa Retail Jewelers' Association will hold their next convention in Des Moines, Ia., June 23, 24, 25 and 26, with headquarters at the Savery Hotel. The officers for the opticians are: A. F. Thompson, Adel, president; B. M. Bills, Vinton, vice-president; Geo. J. Feige, Des Moines, secretary. The jewelers' officers are: Mack A. Hurlbut, Ft. Dodge, president; A. W. Carpenter, Burlington, vice-president; N. Nielson, Harlan, secretary-treasurer.

The Chattanooga News, March 28, contained an interesting cut made from a photograph of the Hotel Patten silver, standing beside which is Susie Mae Meyer, the three-year-old daughter of W. A. Meyer, of the G. W. Meyer Jewelry Co. The silver set, which was manufactured by the R. Wallace & Sons Mfg. Co., Wallingford, Conn., was supplied through Mr. Meyer's firm, whose bid was accepted in a competition. Mr. Meyer's firm also furnished the cut glass and china used in this hotel.

Chas. G. White was recently incarcerated in the County Jail at Jacksonville, Fla., on a charge of larceny preferred against him by Hess & Slager, jewelers of that place, by whom the accused was formerly employed. The officers who investigated the case found that a watch and fob, missed from the jewelry concern, had been pawned in a local pawn shop. The holder of the pawn ticket was located, and it was learned from him that he had received the watch and fob from White. It was also learned that when he purchased the watch he did not know that it had been stolen. White came to Jacksonville about six months ago from Philadelphia.

The Senate has passed and the House of Representatives is now considering an act authorizing the Secretary of the Navy to accept and care for silver services and other gifts presented to the vessels of the navy. The act provides: "That the Secretary of the Navy is hereby authorized to accept and care for such gifts in the form of silver, colors, books or other articles of equipment or furniture as, in accordance with custom, may be presented to vessels of the navy by States, municipalities or otherwise. The necessary expense incident to the care and preservation of gifts of this character which have been or may hereafter be accepted shall be defrayed from the appropriation 'equipment of vessels.'"

MONTANA SAPPHIRES

AT ATTRACTIVE PRICES

Where uniformity of size, evenness of color and quality are essential, our stock of Montana Sapphires particularly commends itself.

Pearls and practically every precious and semi-precious stone but the diamond.

BUY FROM THE CUTTERS

AMERICAN GEM & PEARL COMPANY

14 & 16 CHURCH STREET, NEW YORK

London, 16 Holborn Viaduct

Paris, 39 Rue de Chateaudun

FROM MINES TO MARKET

CORAL

All Kinds of Coral
Specialties for Jewelers

**DROPS
BUTTONS
LENTILLES**

**CORAL
NECK-
LACES**

All Shades
and Sizes

Graduated and
Uniform



CORAL MANUFACTURING COMPANY

CORAL

**Extra Rose
CORAL
A Specialty**

Gold Medal
St. Louis, 1904

Grand Prix
Liege, 1905

BORRELLI & VITELLI

3 Via Amedeo,
Terre del Greco Italy

401 Broadway, New York
Telephone, 5412 Franklin

19 Rue d'Hauteville,
Paris, France

Tel. 4457 } Cort.
4458 }

JOHN M. RICHARD

2 MAIDEN LANE
Room 302, NEW YORK

American Pearls and Baroques

MATCHED PAIRS FOR EARRINGS

The Largest and Finest Assortment in the Market, Mounted and Unmounted.

North Attleboro.

Whiting & Davis took account of stock the latter part of last week.

K. L. Taylor, western salesman of Riley & French, is at the factory.

George L. Paine and Clarence King were in New York, last week, on business.

Alpin Chisholm and G. Cheever Hudson are planning a pleasure trip to Europe next week.

Amos H. Black lost part of a finger under a stamp at the factory of Codding & Heilborn Co., Thursday.

Robinson Bros., Plainville, are closed for several weeks, so that they may move to the new quarters. Extensive repairs are being made to the new home of the concern.

William H. Bell, Fred S. Gilbert, Frederick E. Sturdy and Walter B. Ballou were selected by the local Republicans to represent them at the State convention, where delegates are chosen to the Chicago gathering.

George Maintien, of Maintien Bros. & Elliot, has returned from a lengthy visit to Jamaica. He was given a cordial welcome back by his friends, who burned red fire and serenaded him with horns. Mr. Maintien is much improved in health.

The New York, New Haven & Hartford Railroad officials have agreed to a change in the time table, so that the afternoon train for Providence shall leave at 1 o'clock instead of 1.44. The shift in the schedule will accommodate local jewelers who desire to make connections with the 2 o'clock New York train.

Joseph A. Codding, treasurer of the Codding & Heilbron Co., has filed the annual report of the concern with the Commissioner of Corporations. The report, which is very gratifying, is as follows: Real estate, \$13,975; machinery, \$30,000; cash and debts receivable, \$64,486; manufactures and merchandise, \$38,177; total, \$146,638; capital stock, \$40,000; accounts payable, \$43,440; surplus, \$63,198; total, \$146,638.

Another transaction in which the funds of the closed Jewelers' National Bank are implicated has become known when Receiver Charles G. Baneroft filed his appearance in behalf of the bank in a suit against the South Attleboro Comb Co. The suit was brought by the Arlington Co., New York, against the comb company, to recover \$261.60 for goods. Receiver Baneroft wishes judgment postponed so that he may secure an indebtedness of the comb company to the bank.

The American Diamond Co. has been incorporated in Texarkana, Ark., with a capital of \$60,000 to develop diamond property in Pike County. Louis Heilbron is president, Chas. M. Conday vice-president, and Fred W. Offenhauser secretary-treasurer.

Joseph Landis, who died at his home, Lansdale, Pa., recently, in his 72d year, was at one time a well known watchmaker in Doylestown, Pa. The deceased was born in Buckingham, March 21, 1836, but about 10 years ago moved to Doylestown, where he continued in business until 15 years ago when he moved to Lansdale and resided there until his death. He was a veteran of the Civil War and is survived by a widow, a daughter and two sons.

Boston.

The Boston Jewelers' Club will have its next quarterly meeting and dinner April 21.

Maurice D. Connor, inside salesman for John C. Sawyer, will go to Jamaica this month on a recreation trip.

M. C. Windsor, salesman for the C. G. Aldrich Co., who has been ill for the past three weeks, is able to be out again.

Miss Alice Olivia Chick, of the Thomas Long Co.'s bookkeeping department, who is a mezzo-soprano of much promise, gave a song recital at Huntington Chambers last Wednesday.

M. N. Smith, of the Smith-Patterson Co., is on a vacation trip to Georgia and other points south for a couple of weeks. Henry W. Patterson, also of the company, is at Bermuda for a brief outing.

The Petrillo Clock Co., of this city, has been incorporated with a capital of \$50,000. The officers are: President, Joseph Petrillo; treasurer, Antonio Mele; clerk, James J. Tracy, all of Boston.

Nelson H. Brown, being obliged to vacate the store occupied for more than a score of years, as the building is to be razed and a new one erected on the site, has removed to the second floor of the building at 70 Franklin St., where larger and handsomer quarters have been secured.

George P. Reed, one of the old-timers in the watchmaking industry, and an inventor of improvements in watch construction in his younger days, died suddenly, March 23, at his home in the suburban city of Melrose. He was employed in the Waltham and Howard watch factories some years ago.

Carl H. Skinner, grandson of Alvah Skinner, founder of the house in 1839, has purchased the assets of Alvah Skinner & Son from Charles H. Singleton, of Adams & Singleton, trustees in bankruptcy for the old concern. Mr. Skinner has been a clerk and designer of diamond mountings for the firm for the past few years, and has many friends in the trade.

Buyers in town during the week included: F. G. Vancore, Colebrook, N. H.; George T. Springer, Portland, Me.; C. H. Sinclair, for N. C. Nelson, Concord, N. H.; E. F. Welch, Westboro, who has just returned from a trip to Jamaica; Guy O. Vickery, Augusta, Me.; J. H. McGovern, Haverhill; C. P. Forbes, Greenfield; H. A. Wippich, Provincetown.

The American Watch Tool Co., of Waltham, Mass., through Treasurer Silas A. Barton, has filed the following annual corporation report with the Secretary of State at Boston: Real estate, \$23,552; machinery, \$49,100; cash and debts receivable, \$17,392; manufactures and merchandise, \$38,692; patterns, \$2,092; treasury stock, \$1,300; profit and loss, \$10,981; capital stock, \$22,000; accounts payable, \$4,123; floating debt, \$34,500; surplus, \$22,486.

Johnson, Hayward & Piper, owners of a jewelry factory at the railroad end of Clifton St., West Somerville, last week purchased of W. P. Rice a lot of land, 102 x 85, adjoining and parallel to the Boston & Maine tracks, with a frontage on Cedar St., next to the railroad crossing. The land was secured for the site of a new four-story wooden factory building, 100 x

60, for which plans are now being prepared in New York, under the direction of Mr. Piper, of the firm.

Warren S. Green, jeweler at 655 Main St., Cambridge, was swindled to the amount of \$82 worth of watches and chains last Wednesday by a stranger, who played an ancient game on him. After selecting articles of the value named, the man asked Green to go with him to his boarding place to consult with another party about the purchase. The fellow unlocked the door of the house, letting himself and Green in, and then asked to be excused a moment, leaving Green standing in the reception hall. The man has not been seen since, and the landlady informed the jeweler that the lodger had engaged a room in the house only the previous day. A description of the thief gives his age as about 35 years, height five feet six inches, complexion dark, hair black, face smooth shaven.

Attleboro.

Frank H. Sadler, of the F. H. Sadler Co., has returned from a period of rest at Palm Beach, Fla.

The Bliss Bros. Co. has closed down its factory for a few days to make certain interior improvements.

Thomas E. McCaffrey, of the Hassen, Bennett Co., has been made Attleboro delegate to the coming grand lodge convention of the Elks at Dallas, Tex.

William H. Smith, for 30 years in the firm of Smith & Crosby, retired yesterday. His partner, Alfred R. Crosby, takes in as associates George and Fred Crosby, his sons.

Harford A. Capron, a retired manufacturer, died Monday, aged 79 years. He was formerly a member of Capron & Coe, and later with Frank and Herbert Capron in the firm of H. A. Capron & Co. Of late years real estate interests have occupied his time.

Harry S. Kayser, foreman for J. W. Luther & Co., surprised the millinery world and all his friends in this town, where he is known as a clever jeweler only, by sending to a national millinery convention in Chicago last week a hat which won first prize—a gold medal. It was his own design.

The Electric Chain Co., through Treasurer Thomas S. Bennett, has filed with the Secretary of State the following annual corporation report: Machinery, \$47,903; cash and debts receivable, \$81,489; merchandise, \$27,643; patent rights, \$1; capital stock, \$25,000; accounts payable, \$53,673; surplus, \$7,311; profit and loss, \$71,052.

The Cohannet Silver Co., Taunton, through Treasurer John J. Nichols, has filed the following annual corporation report: Real estate, \$2,500; machinery, \$8,179; cash and debts receivable, \$27,103; manufactures and merchandise, \$40,213; capital stock, \$10,000; accounts payable, \$2,053; floating debt, \$36,000; profit and loss, \$29,942.

Col. Sidney O. Bigney, of S. O. Bigney & Co., continues to be one of the most active men in the State, in pursuit of his desire to be a State delegate-at-large to the Republican National Convention. He spoke last week at gatherings in Northampton,

Springfield, Holyoke and other western Massachusetts points. Absolute frankness in stating what he wants and why he wants it has made him a marked man for caricaturists and fancy newspaper writers this campaign. His "whirlwind handshake," his prodigality with watch chains and the suppers he has given, winning him the title of "the foe to the empty stomach," have become famous all over the State.

Referee in Bankruptcy Clifford P. Sherman, sitting at Taunton last week, heard the circumstances of the case of Leroy D. Bramer, the jobbing jeweler who disappeared mysteriously last Fall, and whose business is now being closed up for the benefit of creditors. Claims were allowed as follows: D. F. Briggs Co., \$2,330.50; W. J. Feeley Co., \$97.38; O. E. Place & Sons Co., \$188.61; E. L. Spencer & Co., \$533.91.

Charles M. Robbins, of the Chas. M. Robbins Co., returned Friday from an extended foreign tour in search of new business to supplement the demands of a flagging domestic market. The trip proved successful, and he discusses it with decided satisfaction. At the opening of the year Mr. Robbins declared that he meant to seek a foreign market rather than wait for things to get better in this country. True to his promise, he left almost immediately for Mexico, the countries of Central America, Cuba, and then across to Hawaii. "It certainly paid," he says. "The expense was very large for the volume of business secured, I will admit, but any manufacturer figures the expense will be comparatively large to break into new territory and take a first order. As to the results, I have only to point to the fact that my factory is one of the very few running with full force and full time. My health has also been benefited by the trip." Mr. Robbins is now prepared for the next few months to throw himself with renewed energy into his campaign for Congress, to represent the 14th Congressional District of Massachusetts.

Brockton.

Edward Jackson, of this city, has purchased the Davis jewelry and optical establishment at Tilton, N. H.

S. W. Baker, of Rockland, was elected president of the Southeastern Association of Optometrists, March 24, at its meeting in this city. The other officers are: First vice-president, W. L. Bemis, Brockton; second vice-president, C. H. Everson, Plymouth; secretary and treasurer, R. N. Sawyer, Brockton. The standing committees will be appointed later by the new president. The meeting marked the completion of one year of successful organization, all reports being favorable.

Uriah C. Smith, 92 Main St., made an elaborate special feature last week of the 21st anniversary of opening his store on its present site. He came to Brockton from Fall River, with a knowledge of the jewelry business and ability as an optician. For a dozen years he had a monopoly of the optical end in the community, and his jewelry business has grown from half a store with one show window and the proprietor the only clerk to two floors, with full equipment and nine clerks.

EICHBERG & CO.,

IMPORTERS AND CUTTERS OF

DIAMONDS,

65 NASSAU STREET, (Prescott Building.) NEW YORK.

"There is Nothing in the Art that we cannot do."

Special Attention

GIVEN TO OUT OF TOWN ORDERS

The International Gem Co., Inc.

12-16 JOHN ST., NEW YORK

TELEPHONE 1241 CORTLAND

Lapidaries and Importers of Precious Stones

SPECIALISTS IN REPAIRING AND REPOLISHING RARE AND VALUABLE GEMS
DRILLING—ENGRAVING—SLITTING

HIMALAYA MINING COMPANY

MINERS AND CUTTERS OF

PRECIOUS AND SEMI-PRECIOUS STONES

537 FIFTH AVENUE

NEW YORK

LONDON
PARIS

OBERSTEIN
PROVIDENCE

VARISCITE SOHN & HYMAN

47-49 MAIDEN LANE

The Newest Stone for High Class Jewelry NEW YORK

ARTHUR REICHMAN

DEALER IN

AMERICAN BAROQUE PEARLS

65 Nassau St.

New York

LOUIS FELDENHEIMER

Importer and Cutter of

PRECIOUS STONES AND PEARLS

41 MAIDEN LANE

NEW YORK

TRADE



MARK

Geo. O. Street & Sons

35 Maiden Lane, New York

Established 1837

RINGS

SLEEVE-LINKS

SCARF-PINS

FOBS AND SEALS

New York Tortoise Shell Co.

13 EAST 30TH STREET,
Just East of Fifth Ave.

NEW YORK

Manufacturers of Fine

TORTOISE SHELL GOODS

Repairing given prompt attention.

Pittsburg.

TRADE CONDITIONS.

Business has begun to improve throughout the Pittsburg district, and dealers are much more hopeful than they were a few months ago. Many men are being employed and thousands have returned to work throughout the district during the last two weeks. Most of the big steel mills are again in operation, though some of them are not running full time. There are also idle railroad cars. The volume of business done has not equalled that enjoyed a year ago, but trade is unquestionably picking up. The weather during the last week also has been an important factor; the days have been extremely pleasant and there has been a brightening in all lines of business. Jewelers expect to do a very fair Spring trade.

Warren W. Mather has returned from a successful trip to Maryland and West Virginia.

George W. Biggs, of the John M. Roberts & Son Co., who has been ill for three weeks is out again.

George S. Dunbar has returned from an eastern trip made in the interest of the Geo. B. Barrett Co.

R. H. Wolfe, Smithton, and B. F. Robinson, Clarksburg, were in Pittsburg, last week, calling on friends.

Henry A. Barrett, of the Geo. B. Barrett Co., was well enough last week to spend a few hours at the store. He was elected president of the company after his father's death.

S. Davis, of S. Davis & Co., whose illness has been noted from time to time, is recovering and will soon be able to conduct his business personally, giving a part of his time to the store now.

Walter Myers was convicted here last week for robbing the home of Homer J. Lindsay, deceased partner of Charles O'Brien, in the firm of Chas. O'Brien & Co., now out of business. Myers was sent to the penitentiary for four years and three months.

A charter has been applied for by the Pittsburg Association of Optometrists, the object of the association being to study the science of optics and to discourage the indiscriminate sale of spectacles by irresponsible persons.

The members of the Jewelers' Duckpot League rolled match games last Thursday night on the Dispatch alleys. The Robert Team, No. 1, took two out of three game from the Vilsack's; the Terheyden's lost all three to the Roberts, No. 2, and the Reed took two out of three from the Wattle Team, No. 2. Great interest is being manifested in the games.

A bold robbery was committed at 5.3 o'clock Friday morning, the thief breaking the south show window of the store of R. Reed & Co., at 439 Market St. Hurlingly snatching up 10 gold-filled watches he made his escape before the police arrived. Alfred Reed, of the firm, was telephoned to and was soon at his place of business. The valuable goods were found untouched, the watches stolen being not valuable. The plate glass window was broken with some blunt instrument. The window has been replaced, the glass having been insured. It is evident that the thief had kept close watch on the corner policeman at Fifth Ave. and Market St. and also on the night watchman, as neither saw a sign of robbers.

Philadelphia.

Willis S. Porter, Burlington, N. J., has returned from a business trip to New York.

John Shearer, with H. B. Gill, casemaker, 618 Chestnut St., is reported to be seriously ill.

B. F. Rhoades, Jr., general engraver, has started in business for himself at 36 S. 7th St.

C. F. Rumpp & Sons instituted suit in the local courts last week against George C. Ittel on a contract.

Henry Muenchenberger, Norristown, Pa., has been made defendant in a petition in bankruptcy filed against him by creditors.

Walter Sheppard, 10th St. and Spring Garden St., has gone to Atlantic City, N. J., to recuperate after an illness with the grip.

Frank Harder, manager of the Martin Jewelry Co., Bloomsburg, Pa., has moved to quarters in the Sharpless building, Bloomsburg.

F. X. Lieberman, 3525 N. 5th St., is convalescing from the effects of a charge of bird shot. He was accidentally shot while gunning recently.

William Gibbons, 40th and Market Sts., has just returned from an extended trip which he made on business through Louisiana and Alabama.

Louis, Abe and Ed. Sickles, of M. Sickles & Sons; Philip Kind, of S. Kind & Sons, and Frank Pfealzer were among those who attended the Purim Ball last week.

The retail store of L. W. Laubach, 7034 Woodland Ave., was threatened by a fire, which broke out in the dwelling portion of the building, last week, but escaped damage.

Charles Gabler, watchmaker for the trade, 722 Sansom St., is seriously ill with an attack of asthma. On account of his age his condition has caused anxiety to his friends in the trade.

Isaac M. Garfinkle, formerly a retail jeweler and at times a pawnbroker, is being prosecuted by the Mercantile Appraisers for carrying on an auctioneering business at 228 Market St., without having paid the city treasurer \$501.75 as a State tax.

Fred Hurlburt, of H. O. Hurlburt & Sons, sailed Wednesday last on the *Adriatic*, from New York, for a pleasure trip to Europe, accompanied by his mother and sister. W. H. Dawson, city salesman, is seriously ill and has been confined to his home over two weeks.

D. V. Brown, 740 Sansom St., returned Friday from a month's stay in Florida. Upon his return he was surprised by entering a handsomely refurnished private office. The work had been done during his absence and without his knowledge by A. V. Brown, his son and business associate.

Proposals were opened March 27 by Lieut.-Col. F. G. Hodgson, depot quartermaster, attached to the office at 26th St. and Gray's Ferry Road, for furnishing silverware for the army transport service. Bids were received from all parts of the country. No awards have yet been announced.

A charter was granted Saturday by the State authorities at Harrisburg to the Pennsylvania Watch Case Co., incorporated at York, Pa. Ellis S. Lewis is treasurer of the company, and the capital stock is

reported to be \$150,000. Articles of incorporation were also granted to Hausmann & Co., of this city, opticians, Frederick W. Hausmann, treasurer; capital, \$5,000.

Fred T. Barry, with J. A. & S. W. Granbery, Newark Ave., is spending a few days at his home in Germantown, this city, after having returned from a long western trip. Mr. Barry says that business in the west is beginning to look brighter, although retailers are still buying sparingly. He says stocks are being permitted to run down and that the Fall trade is almost certain to be brisk.

Morris A. Ritch was last week appointed receiver of the bankrupt estate of Naum Rosenbaum, a retail jeweler, who until recently conducted a large and elaborately furnished store at 19 S. 9th St. Mr. Ritch has ordered a sale at public auction of the stock of diamonds, watches, jewelry and silverware, to be held Thursday, April 9. George W. Carr and Levi & Mandel are attorneys for the receiver.

George B. Soley, one of the oldest and best-known engravers in the city, who for many years was a badge and medal maker at 1305 Arch St., which business he conducted in his leisure time while continuously employed in the engraving department of the United States Mint, died Thursday of last week at the age of 65 years. The funeral was held Monday from his late residence, 3400 N. 17th St. Mr. Soley had been employed in the Mint since 1868.

James Collins, the man who, representing himself as a worn-out crook of international fame and who, on the strength of his story, obtained what he asked for, 90 days in jail, as reported in THE CIRCULAR-WEEKLY of last week, proved upon inquiry to be all that he says he is. He was once a runner and afterward was with circuses in races with horses. Then he robbed a jewelry store in Denver of a tray of diamonds and served a term in jail.

D. C. Hart, watchmaker for Francis B. Wallen, 405 Broadway, Camden, N. J., is spending a few days with his brother, S. W. Hart, a retail jeweler, of Kenneth Square, Pa. Mr. Wallen, who takes an active part in municipal matters in Camden, appeared before the City Council last week and made a speech advocating a handsome new Pennsylvania Railroad station to replace the Haddon Ave. station. Mr. Wallen's speech was warmly applauded.

Local jewelers are expressing keen regret over the retirement from the "road" of Charles Duffy, with Enos Richardson & Co., who, covering this city for the past score of years, became well known and much liked by the local trade, and was also very popular among members of the Jewelers' Club, who had repeatedly honored him with important offices. Fred Keller, who succeeds Mr. Duffy, was in this city last week and was given a cordial welcome, despite the disappointment felt at Mr. Duffy's retirement.

Among the out-of-town visitors visiting this city during the week were the following: R. W. Quicksall, Mt. Holly, N. J.; Roland Oliver, Burlington, N. J.; M. E. Hunter, Beverly, N. J.; Wm. Huber, Elmer, N. J.; Henry Bolte, Atlantic City, N. J.; George Bowen, Bridgeton, N. J.; George K. Ware, Atlantic City, N. J.; John

MacPherson, Mauch Chunk, Pa.; George T. Press, Oxford, Pa.; Howard Fitzsimmons, West Chester, Pa.; J. M. Norcross, Pemberton, N. J.; William H. Reisner, Hagerstown, Md., and Wm. F. Pyle, Street, Md.

A general invitation was extended Saturday by the Historic Committee on Founders' Week celebration next Fall to the public to lend for exhibition historic objects or collections pertaining to the city's industries, including watch and clock making. Leslie W. Miller referred to the admirable pewter which was first manufactured in this city, and to the old clocks for the manufacture of which, in the higher astronomical grades, Philadelphia was once famous. A special sub-committee will superintend the collection of the various exhibits, and it is believed that many old porcelains, hall clocks, watches, etc., will be loaned.

Lancaster, Pa.

Clarence S. Moore, Columbia, celebrated his 71st birthday on March 27.

F. A. Peters, of the H. S. Meiskey Co., visited eastern Pennsylvania last week.

John J. Bowman, of Ezra F. Bowman's Sons, paid a business trip to Reading last week.

Michael J. Garman, a retired Baltimore jeweler, spent last week among Lancaster friends.

There will not be a single change of location among the Lancaster jewelers the first of April, which is "moving" day in this city.

Frank P. Dane, Topeka, Kans., paid a business visit to Lancaster last week, stopping over a few days while en route to New York on a buying trip.

Parke K. Fulmer will sail for Liverpool the second week of April, visiting a number of places of interest before taking in France and Germany.

Among the jewelers visiting Lancaster last week were C. E. Shuey, State College, Pa.; Godfried Schlegel, Chicago; Marcus Kilbrunn, Cincinnati; Levi Poisal, Shamokin; Dennis B. Mowbray, Scranton; Alex. Senft, Washington, D. C.

G. William Reisner has just finished two dozen solid gold pins for the Archery Club of St. Mary's Academy, Notre Dame, Ind., and he has just finished very handsome Past Exalted Ruler's jewels for the lodges of Elks of Lancaster, Milton and Chambersburg.

The handsome gold badge in the shape of a lyre, suitably inscribed, which was presented a few evenings ago by the Germania Maennerchor of Lancaster to Henry Fellman, as a token of appreciation for his work in the order, was furnished by S. Kurtz Zook.

The students of the technical school have organized a baseball team, with F. A. Dietz as captain and manager, and are open to challenges from the teams of other technical schools. Jacob Ziegler, Shock's Mills, Pa., has left the school to take a position as watchmaker with George H. Muhlenburg, at Morgantown, Pa. Curtis Brocius, of Summerville, Pa., has entered the school as a student in engraving. James M. Eise-man, with W. H. Eidem, of Greensburg, Pa., has finished his course at the school and returned to Jeweler Eidem.

ANNOUNCEMENT

On May 1st,

THE GORHAM COMPANY

will remove its Maiden Lane store to the New Silversmiths Building, Nos. 15, 17, 19 Maiden Lane, occupying the ground floor and basement.

THE STORE NOW OCCUPIED BY US
AT NOS. 21 AND 23 MAIDEN LANE,

FOR RENT

Apply to

GROSS^{AND} GROSS COMPANY
MANAGERS

COURTLAND E. HASTINGS, Agent
171 Broadway, Room 5

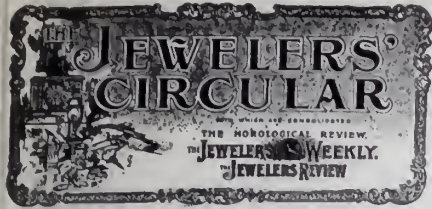

PUBLISHED EVERY WEDNESDAY BY
THE JEWELERS' CIRCULAR PUB'G CO.
 L. J. Mulford, Pres. & Treas. V. S. Mulford, V. P. & Sec.
 11 JOHN ST., COR BROADWAY, NEW YORK.
 TELEPHONE: CABLE ADDRESS:
 1148 CORTLANDT. JEWELAR, NEW YORK.

VOL. LVI. APRIL 1, 1908. No. 9.

Subscription in United States and Mexico, \$2.00
 Dominion of Canada, 3.00
 Other Countries in Postal Union, 6.00
 Single Copies, .10

Remit by check or money order. Remittances in money are at sender's risk.

Index to News and Special Articles.

	Page.
Massive Punch Bowl of Montana Silver Service. Illustrated on front cover; text on...	43
Beautiful Sterling Silver Banquet Service Presented to United States Battleship Montana	43-44
Repoussé Work and Chasing—(Continued)...	45
Interesting Patent Suit Over Clutch for Scarf-Pins Begun in the United States Circuit Court	47
Jewelry, etc., Exported From New York	47
Tariff Decisions by General Appraisers	47
Commissioner Decides That Bankrupt Brooklyn Jeweler Robbed Himself and Orders the Return of Stolen Property	49
Death of George C. Schrieber	49
Death of Benjamin Westervelt	49
Letters of Comment on the Proposed Watch Case Law	51
Death of Axel F. Anderson	51
Death of Albert C. Wittnauer	53
Short Change Swindler Gets Jewelry Worth \$1,150 From Chicago Dealer for \$19	53
Gold Bars Withdrawn and Exchanged	53
Association Notes	53
Examination in Bankruptcy Proceedings Against Kleinschmidt, Howland & Co.	55
Imports of Clocks, Jewelry, etc., Into Canada	55
A. L. Blackmer Co. Makes an Assignment	55
Importations at New York	55
Death of Oscar F. Eisenmann	56
Chas. D. Tucker Goes Into Bankruptcy	56
Beautiful Silver Cup Presented to Oscar Hammerstein	57
Creditors of B. Kahn & Bros. Meet in New York and Reject Offer of Settlement	57
Death of Emerson Tyrell	57
Cultivation of Mexican Pearls	57
Silver Market	71
New Enterprises	71
N. H. White & Co.'s Team Win Championship in Bowling League Tournament	84
F. L. Schuster, Texakana, Ark., Goes Into Bankruptcy	84
Patent Department	89
Catechism of Lever Escapement—(Continued)	91-93
No Reimbursement for Milwaukee's Ruined Street Clocks	93
Completion of America's Largest Tower Clock	95-97
A Handless Watchmaker	97
Bureau of Standards, Washington, D. C., Makes Some Interesting Experiments in Rating Watches	97
A Mechanical Window Display	104
An Easter Window Display	105
A Representative Retail Jewelry Store of Waverly, N. Y.	105
Retail Advertising Department	106
Arguments Used by Jewelry Advertisers	107
Workshop Notes and Queries	109
Metallizing Non-Metallic Objects	109
Solution of Platinum in the Preparation of Chloride of Platinum	109
Austrian Porcelain and Vienna Ware—(Concluded)	111
Gold Cup Presented to Baltimore, Md., Firm on 50th Anniversary	111
B. yers' Information Bureau	113

Newspapers Made | T would seem that
 to Correct Errone- | the jewelers of
 ous Reports. | the country have
 taken the advice given

then in this journal and proceeded to contradict in no uncertain way the rumors and reports in regard to the diamond situation that have been published in the daily papers. In all parts of the country we hear that the newspapers which have published unfounded stories as to a "war" between the Premier and the De Beers companies and predicted a decrease in the price of diamonds, have been shown their errors and forced to correct them. In some cases jewelers have insisted on the papers printing interviews with them, giving the true facts as to the diamond trade; in others they have sent signed statements denying the reports published, and in still others they have supplied the paper with all cables and other authentic information received from the other side, and in a large number of instances jewelers had their local papers reprint the accounts of the situation from and the editorials published in THE CIRCULAR-WEEKLY.

For instance, in Minneapolis, under the leadership of J. B. Hudson and others, the retail merchants took quick action after the Minneapolis Tribune had published a ridiculous editorial entitled "Diamonds on the Bargain Counter," and not only did they have this denied in other papers, but they also had the Tribune publish on the following day a letter signed by J. B. Hudson & Sons, White & McNaught, H. F. Legg, Eustis Bros. and the American Jewelry Co., in which they challenged the statements in the editorial and submitted the article published in THE CIRCULAR-WEEKLY March 18 giving the cables from the London Syndicate and the Premier Co., which the Tribune published in full with the letter. At Little Rock, Ark., the jewelers had the Gazette republish in full the article in our issue of March 18; at Memphis the jewelers had the same editorial republished in the Commercial Appeal, while in Wheeling, W. Va., jewelers also obtained a denial of previous reports in their local papers by having published a full extract from an editorial in a recent issue of this journal. Members of the Maryland Retail Jewelers' Association took official action on the newspaper reports and succeeded in getting a long article in the Baltimore American, in which a complete statement of the exact facts as to the situation was made and also quotations from THE CIRCULAR-WEEKLY's articles in addition to interviews with prominent Baltimore jewelers on the subject. And so on throughout the country the instances that could be cited are so many that lack of space forbids individual mention, but generally the retail jewelers and traveling salesmen in nearly every city of the country succeeded in getting into their local papers an interview, an extract from THE CIRCULAR-WEEKLY or an extract from some of the letters sent out by the large diamond importing houses, giving true facts bearing on the diamond situation and correcting the previously published unfounded reports.

The action taken by the Jewelers' Board of Trade last week in sending out to the

To insure publication all changes of copy for standing advertisements must be received not later than Friday noon preceding date of issue.

press a public letter explaining the situation also did an immense amount of good as this was not only published by the daily papers of New York and vicinity, but was copied by papers throughout the country, either in whole or in part, and was used as an official statement on the situation from the organization best versed in and most competent to speak upon the subject. This letter, by the way (which appeared in full in the last issue), should be used by all jewelers whose local papers have not yet contradicted their first erroneous reports, and we have no doubt that they can have this published either in full or in part by using proper effort.

The "Hundred Dollar" Clause Interpreted. MEMBERS of the trade who have been annoyed at the loose interpretation

often given by customs officials to the so-called "\$100 exemption clause" of the tariff act, which permits returning residents to bring in, duty free, articles to that amount purchased abroad, will no doubt be pleased to learn that the United States Circuit Court of Appeals of the Eighth Circuit recently handed down an elaborate decision in regard to this clause, in which it takes up the interpretation from an entirely new standpoint, and, in fact, declares that the \$100 exemption applies only to wearing apparel, articles of personal adornment and similar personal effects of residents of the United States; also that this clause cannot properly give exemption from duty to any article not enumerated under Par. 697, which applies to personal effects for the use of residents and tourists which are necessary and appropriate for wearing for the immediate purpose of the journey and present comfort and convenience of the traveler.

The point came up in a suit rising out of the claim of the administrators of C. Bernays, who brought certain merchandise into San Francisco from Yokohama and entered the articles at St. Louis. Later he claimed the right of free entry under Par. 697, and his protest, which was overruled by the General Appraisers, was sustained by the United States Circuit Court. On an appeal to the United States Circuit Court of Appeals by the United States, this court brushes aside the various technicalities which had played a part in the arguments in the courts below, and treats the question fundamentally. Taking up Par. 697, it shows that the whole paragraph indicates that the exemption from duty is limited to a resident's personal effect, and that the section of it which applies to articles purchased abroad clearly applies to wearing apparel and personal effects which ordi-

A Profitable Investment for You

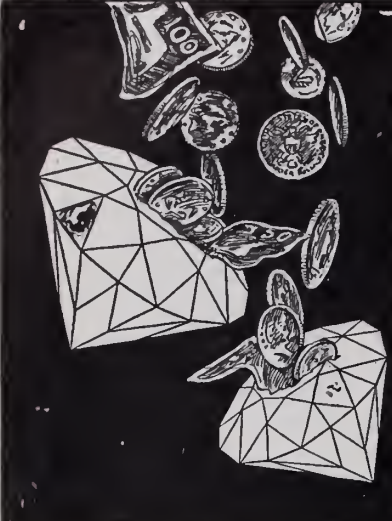

Put your money

and get your customers to put their money in
DIAMONDS
no better investment to-day.

The Jewelers Board of Trade announced recently that cable despatches received here from London said that the De Beers and Premier Diamond Mining Companies, controlling 97 per cent. of all the diamonds mined, had made a contract in which they agreed that there shall not be the slightest reduction from the present prices of diamonds.

We have a large stock of
DIAMONDS
on which we will make very
LOW PRICES
that cannot be duplicated when present stock is sold. We import the stones direct and sell them as close as anybody in the country does for
DIAMONDS
of equal quality. We carry a large stock, Loose and Mounted, and the jeweler who sends to us for a selection not only gets
LOW PRICES
but also a liberal assortment and what is of utmost importance, he gets it promptly. Send us your orders.

V. WAPING, N.Y.

CROSS & BEGUELIN

Importers and Cutters of Diamonds and Precious Stones

43 Rue de Meslay, PARIS

Telephone,
480 John

31 Maiden Lane, NEW YORK



Trade-Mark

OUR guiding principle has always been to incorporate as much artistic skill and good material in the construction of our jewelry as possible. This is contrary to the skimming, economic operations so extensively practiced in the manufacture of inexpensive gold jewelry. In observing this standard we naturally sacrifice the petty profits resulting from the less exacting methods of others; nevertheless our jewelry is consistently low priced and of a quality away beyond the ordinary.

Ask to see it and look for our trade-mark—the imprint of originality and all that's good.

85 Sprague Street
PROVIDENCE, R.I.

H. A. KIRBY

9-11-13 Malden Lane
NEW YORK CITY

narily constitute the baggage of a passenger. After reviewing several decisions upon this, the court stated that

It cannot be that Congress intended the proviso in question (the \$100 exemption clause) as an independent grant of a privilege to returning residents to bring in free from duty any kind of merchandise they might purchase abroad. Such an interpretation of the Tariff Act seems entirely inadmissible.

Unless the words "articles purchased abroad" are limited to the subject matter of the particular paragraph in which they appear, confusion and repugnancy would characterize the whole act. Many, if not all, kinds of merchandise are in some paragraph made subject to a specific duty. Accordingly, unless the limitation just suggested is right, the paragraph under consideration would authorize a returning resident to bring in, duty free, any kind of merchandise which he might purchase abroad of the limited value of \$100, while another paragraph might impose a specific duty upon the same merchandise. Such repugnancy should be avoided if any other reasonable construction can be found.

As the articles in question did not fall within this paragraph, the court decided that they are not entitled to free entry. This decision should put a stop to the practices permitted by the customs officers of allowing residents to bring in presents for others on which an exemption up to \$100 is permitted.

Pacific Coast Notes.

Louis C. Koberg, Healdsburg, Cal., visited Santa Rosa last week.

E. M. Clarke, Riverside, Cal., will soon move his stock into quarters on Harvard St.

W. W. McCausland has completed improvements in his store on S. 5th St., Oxnard, Cal.

H. A. King has moved to 315 F St. Eureka, Cal. He has added a new department of watch repairing in charge of C. F. Reed.

Frank B. Sparks, Loyalton, Cal., has sold his stock to J. W. Montague, who will arrange to engage a jeweler to take charge of the business.

P. E. Anderson, Arcata, Cal., lost a dozen watches, which were stolen from his store last week. They were mostly of the second-hand variety, and some of them were of little value.

M. K. Giant, who has one of the leading stores at Vallejo, Cal., has completed negotiations which placed in his hands 50 by 100 feet of the lot on the west side of Sacramento St.

G. A. Thiel, Redwood City, Cal., in a recent auto accident lost his fine machine but fortunately the occupants escaped injury. In endeavoring to get out of the way of another machine he ran into an iron fence.

In the rush of getting out the last issue of THE JEWELERS' CIRCULAR—WEEKLY the name of the designer and maker of the beautiful silver wreath presented by the Swedish-Americans, to be laid on the bier of the late King Oscar, of Sweden, was omitted from the description of the work which appeared on page 44. This wreath, which was illustrated on the front cover of the last number, was designed and made by the Gorham Co., New York, and when recently put on exhibition at its New York store on Fifth Ave. and 36th St., was the subject of much favorable comment owing to its artistic qualities.

New York Notes.

Oscar T. Jonassolin, 65 Nassau St., sailed Saturday for Europe on the *Koenig Albert*. Mrs. Henry E. Oppenheimer and children sailed Saturday on the *Zeeland* for a trip to Europe.

O. D. Wornser, of Jos. Frankel's Sons Co., 578 Fifth Ave., returned last week on the *Kaiser Wilhelm II*.

At the recent annual meeting of the International Silver Co., the directors of the company were re-elected.

S. Silverthau, of the firm of S. Silverthau & Sons, New Haven, Conn., was a visitor in this city last week.

The Jacob Pohn Optical Co., of this city, has just been incorporated with the Secretary of State with a capital of \$20,000.

Lloyd Church, well-known to the trade in and about Chicago, has accepted a position with M. J. Averbek, 10 Maiden Lane.

L. Tannenbaum, of L. Tannenbaum & Co., 52 Nassau St., sailed Saturday for Europe on the *St. Louis*, of the American Line.

H. J. Hooper, the jewelers' auctioneer, 37 Maiden Lane, has just returned to the city after a successful sale of the W. W. Appel stock, at Lancaster, Pa. This sale was conducted for the Jewelers Board of Trade.

The Pines Jewelry Case Co. has been incorporated under the laws of New York State, with a capital of \$5,000. The directors are Joseph Pines and Henry Greenberg, Brooklyn, and Herbert B. Frank, of this borough.

Members of the S. Rose Co., 20 John St., report that they have disposed of their lot of Brazilian rough diamonds to New York diamond cutting firms. The parcel contained 315 carats, the stones averaging one-half carat each.

The Julius Kronrot Co. has been incorporated under the laws of the State of New York to deal in jewelry, with a capital of \$2,000. The directors are Julius Kronrot, Dora Kronrot and Roman Stone, all of Brooklyn, N. Y.

M. De Dilectis & Co., of Torre del Greco, Italy, have opened a New York office at 529 Broadway, at the corner of Spring St., where they will show a line of loose and mounted corals, shell cameos, mosaics and silver filigree.

Irving Cohn, salesman for M. J. Averbek, 10 Maiden Lane, started Monday for a trip throughout Long Island. He will be absent about a week. Mr. Averbek, 10 Maiden Lane, has added four oak show cases and one wall case to his store equipment. The cases are fitted with electric lights.

The Alfred H. Smith Jewel Co. has been incorporated under the laws of the State of New York to deal in precious stones, with a capital of \$100,000. The directors named in the corporation are F. Bien, W. H. Vogell and T. Adam, all of New York. The corporation is an incorporation of the business of Alfred H. Smith & Co.

Charged with receiving stolen goods, Leo Birdman, a diamond dealer at 140 W. 42d St., was arrested last Wednesday and locked up at police headquarters. According to the police he purchased a diamond brooch and ring which were worth \$265

from a girl who later confessed to having stolen it from her mistress and was arrested.

R. E. Budlong, of S. K. Merrill Co., Providence, R. I., was in this city yesterday. He had just returned from Chicago.

J. F. Braun, 37 Maiden Lane, has gone out of the wholesale business and taken the store formerly occupied by M. Hodes, 2168 Third Ave., where he will conduct a retail business.

The business of Maurice Brower, 16 John St., has been incorporated under the laws of the State of New York with a capital of \$20,000. The directors are Sigmund Wyler, Eugene Kohut and Eugene Cohn, all of this city.

Deputy Sheriff McCourt has served an attachment for \$16,276 against George Chesterman in favor of T. Kirkpatrick & Co., on a demand note made, June 27, 1905, for jewelry. The attachment was granted on the ground that he is a resident of Pittsfield, Mass., and was served on the Corn Exchange Bank, Bank of the Metropolis, and on a representative of the estate of George C. Chesterman.

The Commercial Travelers' Club held a special meeting at their club rooms, Mount Vernon, N. Y., on Saturday evening, at which time they adopted resolutions of respect and sympathy on the death of Benjamin Westevelt, formerly a traveling salesman for the New England Watch Co. He was president of the local Commercial Travelers' Club. The funeral was held Sunday afternoon.

Transcontinental lines have heretofore refused to carry watches as freight, referring inquirers for rates to the express companies. It is thought they will follow the action of western lines which have adopted the following rating: Clocks, watches, in boxes, nailed, strapped and wired with lead seal, average invoice not exceeding \$1 each, first class; average value exceeding \$1, or value not expressed, three times first class.

At a recent meeting of creditors of Victor Jonest, a former importer of jewelry at 33 Union Sq., who filed a petition in bankruptcy in January, William C. Andrews was elected trustee in bankruptcy. Claims were filed and April 3 at 12 m. set as the time for the next meeting. The matter is before Referee Seaman Miller, 2 Rector St. The schedules filed by Mr. Jonest show liabilities of \$49,228 and assets of \$44,099.

Rev. Joseph Irons, 35 Maiden Lane, who for several years represented the Simeon L. & Geo. H. Rogers Co., silver plated ware manufacturers, has brought a suit against the company for alleged breach of contract. The suit is brought in the Supreme Court in this city, and papers were served on R. E. Sage, secretary of the company, last week. It is alleged that an agreement was made by the former management of the company in regard to the sale of goods, and it is over this that the suit is brought.

David Brill, who owns an auction store, 101 Park Row, was auctioning off a collection of jewelry Saturday night when a brick was thrown through the window and landed in a show case filled with jewelry. Several persons were struck by fragments of glass and everybody rushed into the street. A policeman appeared in time to

see a man calmly shifting a tray of gold watches from inside the broken window to his pocket. Mr. Brill charged him with grand larceny in the Oak St. police station. The prisoner said he was George James, 38 years old.

There has been on exhibition during the past week at the Fifth Ave. store of the Gorham Co., the Henry Hudson historical window which is to be placed in the New York Historical building when it is completed. The window represents Henry Hudson discovering Manhattan Island, on Sept. 11, 1609, and shows the historic ship *Halfmoon* at anchor, surrounded by Indian canoes with the green hills of New Jersey in the background. An afternoon scene is depicted showing the descending sun casting its rays on the ship's rigging and upon the surrounding landscape. The window is 14 feet high by 5 feet wide, and is a gift of the Holland Dames of New York to the Historical Society. It was designed by Frank Ready.

Bowling teams representing the Waterbury Clock Co. and Robert H. Ingersoll & Bro., met Friday night at the Rankin alleys, in Park Row, to roll off a tie, each team having won once at previous meetings. The team representing the firm of Robert H. Ingersoll & Bro. won the final series with a total of 2,296 pins, against 2,144 pins for the opposing team. Mr. Givaudan, of the winning team, had an average of 172 in the three games rolled, which was the highest average made. He also rolled the highest total score, which was 517. His single game high score was 200, which was also the best record made. The winning team won the first and second games with 757 pins against 745, and 829 against 655, respectively, but lost the last game by 34 pins.

A meeting of creditors of A. Anzelewitz & Co., 154 Canal St., against whom a petition in involuntary bankruptcy was recently filed, was held at the rooms of the Jewelers Board of Trade, Friday. Stroock & Stroock, attorneys representing the corporation, made an offer to pay 100 cents on the dollar, with interest, in six, 12, 18 and 24 months, the business to be carried on under the supervision of three directors from the creditors until liquidated. The liabilities are \$57,000 and the assets are nominally over \$100,000 in merchandise and accounts. The offer was accepted by most of the creditors present. Mr. Gleason, of Hastings & Gleason, and Mr. McLoughlin, the receiver, verified the figures on the statement. L. P. Kadison, B. H. Davis and B. Scherer were chosen to act in the management of the corporation.

Schedules in bankruptcy of Alfredo Fraganò, 108 Mulberry St., New York, were filed in the United States District Court, New York, Friday, and show liabilities of \$2,399 with no available assets. Among the unsecured creditors are Aisenstein & Woronock, \$441; Jacob L. Schmukler, \$260; L. Shapiro, \$239; Milton Herzog, \$289; H. J. Meyers, \$148; H. Davidson, \$136; Korones Bros., \$130; Cypres & Zucker, 82 Nassau St., \$110; Klipper Bros., \$54; Saltzman & Forman, \$78; Moe Lenkowsky, \$74; Simon Spiro, \$97; Louis

1851

The Jeweler's Bank for half a century
in the same location.

1908

THE CHATHAM NATIONAL BANK

Broadway and John Street, New York

 ACCOUNTS INVITED

GEORGE M. HARD, President

WILLIAM H. STRAWN, Cashier

HENRY L. CADMUS, Assistant Cashier

Title Guarantee and Trust Company

176 Broadway (between John St. & Maiden Lane)
NEW YORK

Capital and Surplus, \$12,000,000 :: The Depositor's best guarantee is a large capital and surplus, together with conservative management

TRUSTEES

John Jacob Astor, 23 West 26th St., New York
 Frank Bailey, Vice-President
 E. T. Bedford, President Corn Products Refining Co.
 Charles S. Brown, of Douglas Robinson, Charles S. Brown & Co.
 Julien T. Davies, of Davies, Stone & Auerbach
 William M. Ingraham, Attorney-at-Law, 44 Court St., Brooklyn
 Augustus D. Juilliard, of A. D. Juilliard & Co.
 Martin Joost, Vice-President Bond & Mortgage Guarantee Co.
 Clarence H. Kelsey, President
 John S. Kennedy, Retired, 31 Nassau St., New York
 Woodbury Langdon, of Joy, Langdon & Co.
 James D. Lynch, Retired, 129 East 21st St., New York
 Ranald H. Macdonald, of R. H. Macdonald & Co., Real Estate
 James H. Manning, President National Savings Bank, Albany
 Edgar L. Marston, of Blair & Co.

Wm. J. Matheson, of W. J. Matheson & Co., 182 Front St.
 Charles Matlack, 70 State St., Boston
 William H. Nichols, Chairman of Board, General Chemical Co.
 William A. Nash, President Corn Exchange Bank
 Robert Olyphant, of Ward & Olyphant
 Charles A. Peabody, President Mutual Life Insurance Co.
 William H. Porter, President Chemical National Bank
 Frederick Potter, 71 Broadway, New York
 Charles Richardson, 1307 Spruce St., Philadelphia
 Henry Roth, 1562 Myrtle Ave., Brooklyn
 Jacob H. Schiff, of Kuhn, Loeb & Co.
 James Speyer, of Speyer & Co.
 Sanford H. Steele, of Steele, Otis & Hall, Attorneys
 Ellis D. Williams, 560 Drexel Bldg., Philadelphia
 Louis Windmuller, of Louis Windmuller & Roelker

BRANCH BANKING OFFICES: 196 Montague St. and 175 Remsen St., Brooklyn; 350 Fulton St., Jamaica; 67 Jackson Ave., Long Island City

The Market and Fulton National Bank of New York

ORGANIZED 1852

81-83 FULTON STREET

Capital, \$1,000,000

Surplus, \$1,500,000

PROGRESSIVE—CONSERVATIVE—SUCCESSFUL

ALEXANDER GILBERT, President
 R. A. PARKER, Vice-President
 T. J. STEVENS, Cashier
 JOHN H. CARR, Asst. Cashier

Invites the Accounts of Jewelers

Will extend every facility that good banking will justify

SAFE DEPOSIT VAULTS

THE STATE BANK

376-378 GRAND STREET, NEW YORK

Capital and Earned Surplus, over \$1,500,000.

Deposits over Fifteen Millions

Offers a favorable market for short and long time jewelry and diamond paper.

The Mercantile National Bank

OF NEW YORK

WILLIS G. NASH, President

MILES M. O'BRIEN, Vice-President

WM. SKINNER, Vice-President

WILLIAM H. TAYLOR, Vice-President

EMIL KLEIN, Cashier

DIRECTORS

WILLIAM F. CARLTON,
ROBERT C. CLOWRY,
WILLIAM NELSON CROMWELL,
L. H. CUTTER,
EDWIN GOULD,
HAROLD A. HATCH,

EDWARD T. JEFFERY,
WILLIAM H. LAWS,
WILLIS G. NASH.
BENJAMIN NICOLL,
MILES M. O'BRIEN,
CHARLES E. PERKINS,

DICK S. RAMSAY,
WILLIAM SKINNER,
E. D. STREET,
WILLIAM H. TAYLOR,
E. J. TRUSSELL,
WARNER VAN NORDEN,

Strictly a Commercial Bank
Accounts Solicited

"ASK YOUR JOBBER"



PATENT PENDING

ONE OF THE NEW

UR

LOCKET RINGS

WHICH NOT ONLY HAS THE ADVANTAGE OF A PATENT SECRET JOINT, BUT HAS THE ADDITIONAL VALUE OF BEING WATER-TIGHT.

The Untermeyer-Robbins Co.

Seventy-One Nassau Street, New York

Gems and Precious Stones

Their Characteristics, Localities of Production, Tests
and Some Current Literature

CLOTH, POSTPAID, \$1.00

Published by THE JEWELERS' CIRCULAR PUB. CO., 11 John St., N. Y.

New York Notes.

(Continued from page 67.)

Dolgin, \$50; R. Finkel, \$56, and Reich & Rottenberg, \$55. Mr. Fragnano is a native of Italy. He came to this country a few years ago and about June 1, 1904, started in business at 107 Mulberry St., with his brother, under the style of Fragnano & Bro. They succeeded M. Voccoli. The firm dissolved Oct. 1, 1906, and later Alfredo opened a business at 108 Mulberry St.

The wholesale and retail jewelry trades of this city and vicinity are notified to be careful in dealing with a tall man about 3 years old, who is said by the police to be a professional thief, and who applies his trade by calling upon jewelers, giving them fictitious orders, and while in the store picks up anything he can lay his hands upon. The man, who has a very dark, swarthy complexion, is of medium build and wears glasses. He is dressed neatly in dark clothes and wears a derby. Sometimes he uses the name of I. C. Huntington, but he may give other names as well. He visited several places, Maiden Lane recently, and in one store where he had ordered goods sent up C. O. D. to a name and place that proved to be fictitious, he succeeded in getting away with a match box. Jewelers on whom he may be called are asked to notify the police should he visit them, or send word directly to the police headquarters.

The examination in bankruptcy of David Kessler, 226 Henry St., against whom a petition in bankruptcy was filed in December, 1907, was begun last Wednesday before Referee Miller, 2 Rector St. Mr. Kessler testified that he had been in the country 16 years and in business 12 years during which time he never kept any books and that he had made no statement to a mercantile agency. He said that he had no general place of business but was around looking for customers and carrying this merchandise in his pockets. He said he had no goods in his pockets after October, 1907, and had done no business since Nov. 1, 1907. He did not expect that a petition in bankruptcy would be filed against him. Attorney Gustavus Roge representing the creditors, then took up the schedules filed by Mr. Kessler and questioned him in regard to the debts due on open accounts. It developed that most of them are not collectible. The bankrupt denied that he was getting ready to go to Europe at about the time the petition was filed. He was directed by the Referee to turn over to the trustee in bankruptcy books and papers relating to his business and an adjournment was taken for Thursday. According to the schedule filed by the bankrupt his assets are \$9,000 and his liabilities \$11,663.

Moritz Greenspan, 221 Broome St., New York, who filed a petition in bankruptcy some time ago, showing assets of \$21,000 with liabilities of \$29,496, has offered a settlement of 20 cents on the dollar, which has been accepted by most of the creditors. Examinations in bankruptcy have been held for some time past before Referee P. Olney. Mr. Greenspan testified that the

ceiver took possession of his store on Feb. 7. He was shown several account books at the first examination, which he identified. He said he did not employ a bookkeeper. He was examined at length during the next meetings as regards his business transactions with various people. Questioned as to one Max Schein and his attempt to collect \$3,068 from him, he said that he failed to find him at 153 Stanton St. Asked about Sam Schwartz, 238 Rivington St., he said he gave him \$517 worth of diamonds and could not find him at the address given. A list of names purporting to be men owing various sums of money to the bankrupt was submitted, and according to Charles Appel, the attorney for the trustee, these people were not found. Letters written them have been returned to the lawyers, and a house-to-house canvass failed to locate any of them. The only stock found at the place of business of the bankrupt when petition was filed was valued at \$102, according to the lawyer's statement.

Trade Gossip.

M. J. Averbeck, 10 Maiden Lane, New York, has just issued a neat booklet of Spring novelties, showing reprints of festoon necklaces, card cases, mesh bags, combs, jewelry, etc. The book is 11 inches by eight inches.

A unique and attractive offering now offered to the trade is the Dubois Safely Chatelaine Brooch Watch. The brooch holds the watch firmly and securely, thus preventing the movement from being jarred. It is so constructed that it can be raised so as to read the time and reversed so as to have either the dial or back exposed to view. It is the only brooch and watch combined, and affords absolute security to the wearer.

An attractive Spring catalogue has just been issued by the W. H. Saart Co., silver-smiths, Attleboro, Mass. The catalogue is bound in light green, and on the front cover appear the photographs of the president, the treasurer and the New York and western representatives of the concern. In the center is a picture of the factory. The catalogue has 16 pages, 12x9½ inches, and the articles made by the firm are illustrated in half-tones on heavy paper.

The W. Green Electric Co. has presented to "Ye Olde Dutch Tavern," 23 John St., a set of the imperial Westminster electric cathedral chimes. The bells toll out in chimes the hours, quarters, halves and three-quarters with wonderfully clear and sweet tones. At the quarter the bells chime four times; at the half, eight times; at the three-quarter, 12 times, and at the hour the full 16 Westminster Chimes, after which the bell strikes the hour.

Fred Hurlburt, of H. O. Hurlburt & Sons, Philadelphia, sailed to-day on the *Adriatic*.

The P. H. Boyson Jewelry Co., Cedar Rapids, Ia., is now located in the Kimball building, on S. 3d St. P. H. Boyson is manager. Mr. Boyson, with his brother, Geo. H. Boyson, came to Cedar Rapids in 1900.



A store has been opened in San Dimas, Cal., by Washler & Stratton.

R. B. Keeler will open a retail jewelry store in Benton, Pa., this week.

Hans Norsby, Fosston, Minn., has started in business at McIntosh, in the same state.

C. N. Brown contemplates opening a store in Winston Salem, N. C., in the near future.

I. Rosenthal has opened a general store in Centralia, Wash. He will carry a line of jewelry.

W. T. Willis recently engaged in the retail jewelry business on Patton Ave., Lafayette, Ga.

The Johnson Jewelry Co. has been organized at Anderson, Ind., by A. L. and J. E. Johnson.

B. F. Rhoades, Jr., engraver, opened a store for himself last week at 36 S. 7th St., Philadelphia, Pa.

C. Y. Kure is about to open a general store in Spokane, Wash., and will have a jewelry department.

Miller & Feldscher have engaged in the retail jewelry business at 258½ S. Main St., Salt Lake City, Utah.

The Fairmont Mercantile Co. has just opened a store with a new stock of jewelry, dry goods, etc., in Fairmont, Minn.

W. R. Wilson, Douglas, Ga., has opened a branch watch and jewelry repairing establishment in Broxton, Ga., under the firm name of Wilson & Walker.

F. J. Gelyres, formerly with T. Lundy, San Francisco, Cal., is purchasing stock for a new store to be opened in Colusa, Cal. The store will be ready for occupancy some time this month.

Henry W. Radder, until recently in the employ of J. S. Baird, Watertown, N. Y., has resigned his position to engage in business on his own account at the same place.

Lux, Bond & Lux is the name of a new concern which recently engaged in business in Hartford, Conn. The concern will buy, sell, manufacture and deal in jewelry and kindred lines. The capital stock amounts to \$50,000. The incorporators are: Geo. L. and Henry E. Lux and Austin M. Bond.

The McKinney Wholesale Jewelry & Photo Supply Co. recently began business in Hutchinson, Kans. The members of the concern are: T. McKinney, of Hutchinson, and J. E. Meek, formerly engaged in business in Arlington. The establishment is located in the quarters now occupied by the jewelry store of T. McKinney. The new concern, however, will be entirely distinct from the latter's retail jewelry store.

George and Ben Metcalf, father and son respectively, were recently taken into custody on a charge of misappropriating nine watches belonging to W. T. Shirley, a retail jeweler of St. Elmo, Tenn. All of the stock was recovered.

Last Week's New York Arrivals.

THE CIRCULAR-WEEKLY each day posts in its office a bulletin of the latest buyers visiting New York, which every member of the trade is cordially invited to copy.

ALBANY, N. Y., J. A. Becker (J. G. Myers Co.), Herald Sq.

F. Sherman (W. M. Whitney & Co.), Herald Sq.; 396 Broadway.

BOSTON, MASS., Miss M. E. Gilligan (Chandler & Co.), Imperial.

H. M. Kinports (H. M. Kinports Co.), Victoria.

DENVER, COLO., B. Petherick (A. T. Lewis & Son Dry Goods Co.), 31 Union Sq.

GREENSBORO, N. C., C. S. Schiffman (Schiffman Jewelry Co.), York.

MOBILE, ALA., T. T. Sandoz (T. F. Sandoz Jewelry Co.), Astor House.

PHILADELPHIA, PA., W. C. Penfold (W. C. Penfold Co.), Grand.

PITTSBURG, PA., W. Rosenbaum (Rosenbaum Co.), Netherland; 31 Union Sq.

ROCKAWAY, N. J., E. Doland (C. Doland & Son), Breslin.

TROY, N. Y., T. E. Burney (G. V. S. Quackenbush Co.), Wolcott.

WILLIAMSPORT, PA., J. W. Mussina, Astor House.

Newark.

A. Joralemon & Son have been incorporated to manufacture and deal in jewelry, with a capital of \$5,000. The incorporators are Sarah G. Joralemon, Charles E. Williams and Charles L. Joralemon, all of this city.

Oscar W. Kohn, of Kohn & Co., sails on the White Star liner *Canopic*, Saturday, on a cruise to the Mediterranean. He will visit the principal points in Italy and the Riviera, and return by way of Paris and London.

The business of Emil Schneider, gold and silver refiner and manufacturer of soldering fluids and fluxes, has been incorporated under the laws of the State of New Jersey with a capital of \$50,000. The incorporators are E. Schneider, O. Schneider and R. W. McChesney, all of this city.

Charles Zemp, Central Ave., Jersey City Heights, has had a warrant issued for Emil Heinrich, a Hudson City man, whose address is not known, charging him with passing a worthless check. He says that Heinrich came into his store and bought a watch and chain for \$78, offering a check in payment. When Zemp tried to cash it he found that it was worthless.

Articles of incorporation of the Lyon & Son Mfg. Co. have been filed. The concern is to manufacture gold and silverware, brass novelties and buttons. The incorporators are: Wm. G. Lyon, East Orange; Joseph F. Papsice, Newark, and Frederick M. Lyons, Newark. Wm. G. Lyons is the agent, with local offices at 109 Oliver St. The capital of the company is \$125,000.

Market Price for Silver Bars.

The following are the quotations of silver bars in London and New York, as reported by Zimmermann & Forshay:

	London.	New York.
		.999 Basis.
March 24.....	25 9-16d.	\$.57 3/4
" 25.....	25 1-2d.	.57 3/4
" 26.....	25 9-16d.	.57 3/4
" 27.....	25 9-16d.	.57 3/4
" 28.....	25 1-2d.	.57 3/4
" 30.....	25 9-16d.	.57 3/4

STERLING SILVER
TABLE SERVICE

FRANCIS I.

A TRIUMPH OF
ART AND SKILL

The New Reed & Barton Pattern

(Design Patented)



A DESIGN OF STATELY ELEGANCE,
TYPIFYING THE SUPREME GRAND-
EUR OF FRENCH RENAISSANT ART

Members of the Trade who have seen
this pattern pronounce it the greatest
of all flat ware patterns. Its enthusi-
astic reception and instant favor have
added fresh laurels to the unsurpassed
reputation of Reed & Barton for flat
ware successes.

The dozen work, cutlery and principal fancy pieces,
are now ready for delivery, and orders are solicited
from the regular Jewelry Trade, to whom prices and
terms will be furnished upon application.

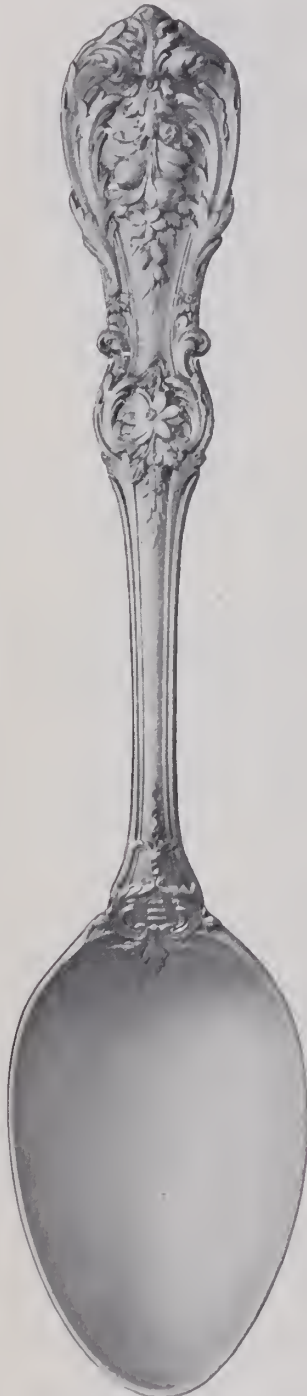

DESSERT SPOON.
Front View.

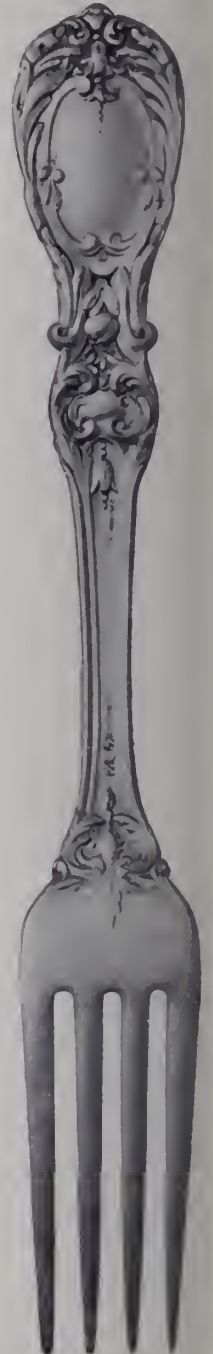

DESSERT FORK
Back View



REED & BARTON, Silversmiths

Established 1824

The Oldest Makers of Silverware of Repute in America

REPRESENTED AT

320 Fifth Avenue }
4 Maiden Lane } NEW YORK

103 State Street, CHICAGO
296 Second Ave., SAN FRANCISCO

OFFICES AND FACTORIES
Taunton, Mass.

Connecticut.

Samuel H. Kirby, New Haven, has sold his house at 5 Whitney Ave., New Haven, to George Bradley.

T. B. Lasher, Bridgeport, has assigned to the International Silver Co., Meriden, a new design for the handles of spoons, forks and similar articles.

P. T. Ives has placed over the entrance to his store a time gong, which will strike every hour, being operated by the Western Union wire direct from Washington.

Miss Harriet Nesbit Bleuher, formerly in the employ of the Wm. L. Gilbert Clock Co., Winsted, died March 23, at her home, 42 Main St., at that place, of typhoid fever.

Damage amounting to about \$300 was done last week to the jewelry store of J. Huber & Co., Waterbury, during a fire. The damage was caused by water, which flooded the store.

President F. A. Wallace, of the R. Wallace & Sons Mfg. Co., Wallingford, is head of the Advisory Board of the Wallingford Water Commission, which is now moving to secure an increase of water supply for the town.

F. W. Cleveland, until recently foreman at the New England Watch Co.'s factory, Waterbury, has resigned and taken a position as master mechanic with the South Bend Watch Co., in South Bend, Ind., where he will move with his family.

Charles H. Tibbits will be one of the Wallingford delegates of the Republican State Committee to elect delegates to the National Republican convention, and either C. W. Leavenworth or F. A. Wallace will be members of the delegation.

The marine and watch departments of the Seth Thomas Clock Co., Thomaston, are now being operated 32 hours a week, the time being divided into four days of eight hours each. The working time in the machine room and tower clock department is now 55 hours a week.

J. Susman, Stamford, was considerably annoyed last week owing to certain complications in which a namesake of his became involved. It was thought by some persons that there was only one Susman in the town, but this proved to be not so, to the great relief of the jeweler.

Edwin P. Root, secretary of the New Haven Clock Co., New Haven, is expected home to-day (April 1), after having spent several weeks in Augusta, Ga., where he went for the benefit of his health. Mr. Root was elected first vice-president of the New Haven Chamber of Commerce, March 24.

Warren W. Wilcox, who recently broke a window in the store of Israel Goldstein, Jr., New Haven, and snatched a tray of diamonds and was shortly afterwards taken into custody, has been sentenced to three months' imprisonment for carrying a revolver and bound over to the Superior Court for burglary.

President G. H. Wilcox, of the International Silver Co., together with a number of other leading business men of Meriden, obtained from City Court Judge Frank S. Fay a temporary injunction prohibiting the use of the town hall auditorium for an athletic carnival on the night of March 20, under the auspices of the Charter Oak Ath-

letic Club. The license was granted to the club, however, by a committee of the Common Council.

Norman Leeds was appointed temporary trustee, March 19, of the Monarch Corporation, which filed an involuntary petition in bankruptcy. The appointment was made by Judge Platt in the United States Circuit Court. The petition was filed, it is claimed, owing to complications caused by the president of the firm, George H. Carpenter, of New York, who, as previously reported in THE CIRCULAR-WEEKLY, has been sued by R. A. Breidenbach, of New York, a diamond dealer. The latter claims he turned over to Carpenter \$138,000 in diamonds and accepted in return stock for several of Carpenter's enterprises.

Providence.

J. P. Goldstein, representing L. Davidsburg & Co., has begun a four weeks' western trip.

L. J. Roy, a member of the L. J. Roy Co., Inc., acted as juror in the Superior Court last week.

Leon Elias, representing Mackey & Elias, arrived in New York last week after a successful western trip.

L. J. Hellman, who has been representing M. F. Williams & Co. in the west, has returned to this city.

Frederick A. Ballou, of B. A. Ballou & Co., is back in this city after having enjoyed the balmy breezes of the south for some time past.

James Peacock, of Peacock, Stone & Markham, who has returned from his western trip, brings back some large orders and reports business picking up.

The Japanese Fuji Co. has established a die cutting and designing plant at 279 Weybosset St. The firm consists of S. Yamamoto, G. Tazo and S. Nagashima.

A. C. Noyes, designer and die sinker, formerly at 101 Sabin St., has moved his factory to Taunton, Mass., where he has better facilities and more commodious quarters.

John Fletcher, of Fletcher, Burrows & Co., was one of eight delegates elected by the State and district conventions last week to attend the National Republican convention at Chicago.

The plant of the Sash Curtain Rod & Novelty Co., of Auburn, was sold at auction Friday to the C. P. Henry Novelty Co., of this city. The sale was ordered by Percy W. Gardner, trustee in bankruptcy. The purchasers will operate the factory in connection with their plant in this city.

The Gorham Co. has completed a statue for the Seventh Rhode Island Volunteers. It will be set up on the battlefield at Vicksburg, and is a bold figure of a standard bearer. A public exhibition of the statue was held Saturday on the grounds in front of the Gorham plant, and was attended by an interesting programme.

Richard W. Farr, who was indicted by the March session of the Grand Jury on a charge of forgery, and who was accused of forging an assignment of pay of one of the employes of the Gorham Co., was sentenced to three years at hard labor in the State prison, Friday, by Judge Sterans, in the Superior Court. The attorney-general, who personally conducted the prosecution, re-

frained from asking for a maximum sentence.

The jewelry plant of the Chase Mfg. Co., 46 Clifford St., was sold Thursday noon at public auction under order of James W. Lees, trustee in bankruptcy. The purchaser was Amos M. Bowen, Jr., and the sale, it is understood, was in the interest of some party or parties who will continue the business in which the Chase concern has been engaged. The price paid was \$3,925.

The arrest of Thomas D. Taylor, one time director in the New England Trust Co., which is now in the hands of a receiver, was viewed with interest by jewelry workers last week. Mr. Taylor is made the defendant in a suit which Receiver Beagan has brought to recover \$350,000 damages, the amount of deposits that the bank had.

Capt. Howard Wilcox, who is a member of Gen. H. S. Tanner's staff, will have charge of the tennis games which will be played on indoor courts in the new armory in this city. The Captain is a member of the firm of Dutee Wilcox & Co., in this city, and was one of the holders of the championship cup for doubles last year. Among other jewelers who are prominently identified with affairs in the new armory are Gen. H. S. Tanner, Major Horace Manchester and Capt. Ralph Hamilton.

Buffalo, N. Y.

Fred C. Smith, traveling salesman for Chas. F. Damm, 520 Main St., is ill with typhoid fever.

Charles F. Fate was arrested early last week on a charge that he had purchased a diamond ring from Frank Ehrenfried, 425 S. Division St., but had paid nothing on it. It was alleged that he tried to sell it to a Seneca St. store, so a charge was preferred against him.

Among the jewelers whom the papers quoted in interviews last week on the subject of the diamond trade was A. E. Sipe, who quoted various cablegrams that had been received by THE CIRCULAR-WEEKLY and the diamond cutters, explaining that the Syndicate and Premier Co. intended to maintain prices.

The Simcox Optical Co., located in the German-American Bank building, has been unable to obtain a permit for a sign, despite the company's promise to make any reasonable agreement or guaranty to comply with the terms of any new sign-taxing ordinance or conform to the old one. The Aldermen are willing the company should have a sign, says Mr. Simcox, but the Councilmen simply sit back and refuse to take any action. He wonders why.

The American Jewelry Co., Charlotte, N. C., is now settled in attractively furnished quarters on E. Trade St.

Two men were recently taken into custody in Denver, Colo., suspected of being implicated in the recent robbery of the store of O. P. Davis, at Ault, Colo. They implicated a man named Preston and denied that they had anything to do with the robbery of the store. They admitted, however, that they purchased a considerable amount of jewelry from Preston.

Appropriate for the Season

We wish to call the attention of the Retail Jeweler to our line of VASES; these vases are always desirable as Easter and Wedding gifts.

Our line this year is very extensive, but we can show only a very limited number of styles and sizes at this time. Prices range from \$2 to \$50 each.

Frank M. Whiting & Co.

SILVERSMITHS

NORTH ATTLEBORO, MASSACHUSETTS
325 Fifth Avenue, New York



4690 Eng.
Made in
14", 17", 20"



4547
Made in
9", 11", 13"

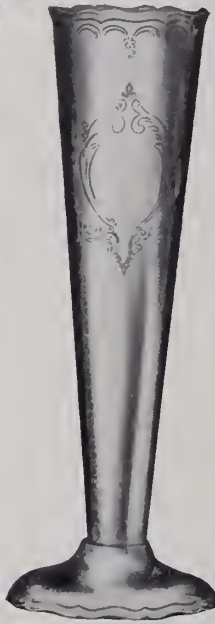

4354 Eng.
Made in
10", 12", 14"



4768 Eng. and Pl.
Made in
5½", 7", 8"



4437
Made in
4", 6", 7½"



4381
Made in
5", 6½", 8"



2423
Made in
5½"



2617
Made in
5½"

Buy Watches With Our Patent Ball-Bearing Bow

Already on the Market

No watch case should be without it.

BEWARE OF IMITATION



Should your jobber not sell cases with these bows, write us and we will give you a list of jobbers who do.
Patented July 25, 1905; May 21, 1907. Other patents applied for.
Patented in foreign countries.

The Wachter Manufacturing Co.

HARTFORD, CONNECTICUT

Canada Notes.

E. J. Newton, Wapella, Sask., has sold out to A. Daykin.

A. G. Hodgson, Moose Jaw, Sask., has purchased the business of P. B. Fitch, High River, Alta.

W. E. Coult, manager of the stationery department of Ryrie Bros., Toronto, Ont., is at Preston Springs, Ont., for his health.

W. G. Challoner, of Challoner & Mitchell, Victoria, B. C., and D. A. Reesor, Brandon, Man., passed through Toronto, Ont., last week, on their return trip home from the European markets.

Grau & Co., Ltd., Toronto, Ont., is seeking to locate in Guelph, Ont., and has made overtures to that city asking for a fixed rate of assessment. It is intended, if this can be secured, to reorganize the company on a larger scale.

The New York Standard Watch Co., of Jersey City, has opened an agency in Toronto, with Mr. Dale as manager, for supplying the Canadian trade with complete watches, putting their Excelsior movements in Canadian-made cases.

The jewelry store of Arthur Brittain, formerly of Toronto, at Wyoming, Ont., was broken into by burglars Monday night, of last week, and a quantity of jewelry was stolen from the show cases. The more valuable goods in the safe were not disturbed.

Out-of-town jewelers calling on the Toronto, Ont., trade last week, included: George Hynds, Acton; J. F. Van Dusen, Dundalk; F. Clark, Peterborough; P. S. Byrnes, Beaverton; W. Klein, of Klein & Binkley, Hamilton; N. Bassett, Whitby, and J. H. McClelland, Hastings—all Ontario.

The opening of a new temple of the Ancient Order Neophytes of the Mystic Shrine, at London, Ont., of which A. E. Cooper, London, is one of the leading spirits, took place Friday. L. Herbert Luke, of Ambrose Kent & Sons, Toronto, attended the ceremony in company with H. A. Collins, past Imperial Potentate.

A. B. Smalley & Son, St. John, N. B., have received information that one of their chronometers with their improved balance has been successful at the annual trial at the Royal Observatory, Greenwich, Eng., ending January last. The competition included upwards of 100 other makers. The Admiralty ordered one of the chronometers, which is the first time such a purchase has been made outside of England.

Baltimore.

Geo. E. Cocqueri was brought back to this city by local detectives from Wilmington, Del., March 21. The accused is wanted here to answer a charge of securing \$34 by means of a bogus check.

M. L. Reeder, of this city, has leased the store at 40 W. Lexington St. from Wm. Charles Keen for the unexpired portion of the lease. Before the fire Mr. Reeder conducted business in the Masonic Temple building.

Ernest Belmont, who was released from Sing Sing prison, March 24, was immediately placed under arrest on a charge of embezzling \$350 from J. Engel & Co., whole-

sale jewelers of this city, by whom he was employed as a bookkeeper.

Benjamin Rosenheim and Edward E. Weiler have been appointed receivers for the jewelry and optical business conducted at 305 W. Lexington St., this city, by Benjamin and Bernard Kahn, under the firm name of B. Kahn & Bros., who, as announced in last week's issue of THE CIRCULAR-WEEKLY, recently filed a petition in bankruptcy. The receivers furnished bonds amounting to \$25,000.

Philip Blum, 70 years of age, was suddenly stricken with heart failure one morning last week, while riding in a car on the Gay St. line, at the corner of Gay St. and North Ave. He was taken from the car and carried to more comfortable quarters, where he expired, however, in a short time. Mr. Blum was a pioneer manufacturer of jewelry and silverware cases in this city. The deceased started in business in 1867 at 109 N. Charles St., where he remained until the big fire. Since that time he conducted business at 206 N. Holiday St. Mr. Blum was born in Nuremberg, Germany.

Rochester.

E. J. Scheer & Co. are running a special red ticket sale of bronzes, electroliers and art goods.

Burglars broke into the jewelry store of Terry & Block a few nights ago and stole several trays of jewelry valued at about \$75. Entrance was effected through a rear door, which was smashed. The stolen articles consisted of stick pins, gold crosses, rings and other jewelry, which could be easily disposed of. The police are investigating.

Edna Eichorn, who brought suit for \$5,000 in the Supreme Court against Isadore Davis and two police officers for alleged false imprisonment, was a few days ago awarded damages to the amount of six cents. The plaintiff and another young woman were arrested at the request of Davis, a State St. jeweler and pawnbroker, on a charge of grand larceny. It was alleged that while inspecting some jewelry the girls took out a diamond brooch valued at \$60. After the girls were arrested the brooch was found in the cellar of the store, immediately underneath the show case. The jurors decided that there was no malice in the arrest and also that neither of the girls was guilty of stealing the brooch. Miss Eichorn has brought suit against Davis for slander.

A clever crook has been trying to swindle jewelers in the small towns in the immediate vicinity of Rochester. A few days ago a man presented himself at the jewelry store of Loren T. Babcock, in Waterloo, and laying a battered watch on the counter asked for a make that the jeweler did not have. He said he was a railroad man and must have a good watch. If Mr. Babcock did not have this make he would leave his watch at the store to be repaired, and Mr. Babcock might loan him a good gold watch until the old one was fixed up. Babcock was not taken in by the man's talk and refused to do business with him. This same trick was successfully played on Williams & Son, of Seneca Falls, where a man believed to be the same who appeared at Waterloo got a \$28 watch.

Kansas City.

TRADE CONDITIONS.

Trade throughout the city is reported quiet, particularly among those dealers and manufacturers who are expecting an after-Easter wedding trade and those who execute special orders for schools, colleges, etc. Collections are fairly good and conditions all round are perhaps as good as could reasonably be expected. Quite a number of retailers have been in town, but they have been conservative buyers and have placed only such orders as their stock requirements demanded.

H. N. Konrad has removed his store from 8th St., near Grand Ave., to 812 Grand Ave.

A. E. Pettinger, of the Kansas City Horological and Optical School, is spending the week at Excelsior Springs.

Mr. Woodstock, of the Woodstock-Hoefer Watch & Jewelry Co., is absent from the city on a business trip through Iowa.

A. Y. Boswell, Tulsa, Okla., who has been putting up a new building and equipping it with up-to-date fixtures, announces a formal opening, April 18.

W. H. Pontious and wife, Anthony, Kans., passed through the city early in the week on their way home from a fortnight's sojourn at Excelsior Springs.

E. Kionka, of Kionka & Kionka, has returned from a trip to Texas. He reports business quiet, but found the people hopeful of better times in the near future.

Charles R. Barto, Kansas City, Mo., and George F. Rathbun, Osborne, Kans., have been enrolled as students at the Kansas City Horological and Optical School.

The opticians and jewelers of Oklahoma will hold their State meeting in Oklahoma City, April 21, 22, 23 and 24. A number of Kansas City jewelers and opticians have signified their intention of attending the meeting.

The Kansas City Jewelers' and Optical Association recently elected the following officers for the ensuing year: C. L. Merry, of the Merry Optical Co., president; W. L. Riggs, of the Columbian Optical Co., vice-president, and C. B. Norton, of the C. B. Norton Jewelry Co., treasurer.

The executive committees of the Retail Jewelers' Association and the Opticians' Association of Missouri, two separate organizations, met last Monday at the Baltimore Hotel and selected June 9, 10 and 11 as the dates for the annual State conventions of the associations and this city as the meeting place.

Among the jewelers in town last week were: C. E. Range, Trenton, Mo.; Mr. Raines, of Raines Bros., Maryville, Mo.; J. A. Zimmerman, Warrensburg, Mo.; W. D. Wilhite, Adrian, Mo.; C. E. Lovelace, Bolivar, Mo.; L. T. McHugh, Chariton, Mo.; C. E. Tieman, California, Mo.; Claud Wheeler, Columbia, Mo.; Charles Bard, Sedalia, Mo.; T. S. Lidstone, Dearborn, Mo.; W. W. Whiteside, Liberty, Mo.; Mr. Cordes, Bodeley & Cordes, Quenemo, Kans.

The store of L. Lippman, 1410 Eleventh Ave., Altoona, Pa., was broken into about a week ago by burglars, who stole a large number of rings. Two hours later a man, believed to have been implicated and known to the police as "Chip" Meyers, was taken into custody. Meyers, at the time of his arrest, had in his possession two rings, one of which bore the jeweler's tag.



GNTERPRISING and successful jewelers everywhere are pushing the sale of some individual line of watches which they believe to be superior to all others, and upon which they can also make a satisfactory and justifiable profit.

This explains the growing demand for ILLINOIS WATCHES, in 0, 12, 16 and 18 sizes, by increasing numbers of leading jewelers throughout the United States.

If you are not familiar with the superior quality of—and advantages gained by handling—Illinois Watches, it will mean reputation and dollars for you to investigate.

Every one fully guaranteed.

Price List sent on application.

ILLINOIS WATCH COMPANY

SPRINGFIELD

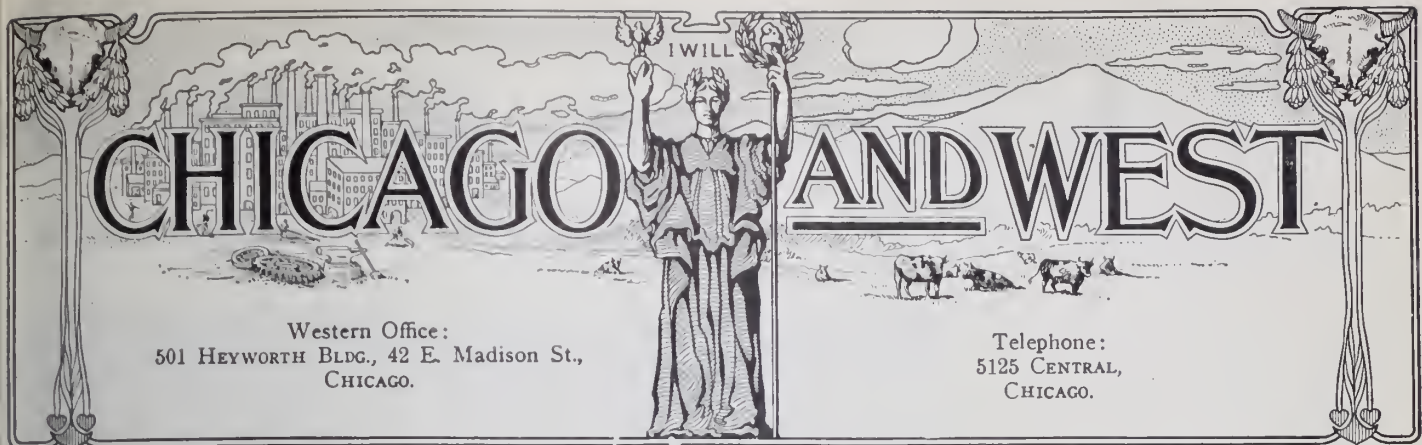

Chicago Notes.

C. H. Knights has returned from Florida and Cuba.

Ed. Trebing is on a duck hunting trip on the Mississippi.

A. Hirsch and family have returned from their southern trip.

F. G. Thearle has sold out his piano business in Englewood.

James H. Rogers, Gibson City, Ill., is holding an auction sale.

D. A. Wilkins, with the Ostby & Barton Co., has returned from the Pacific coast.

Albert M. Dueber, accompanied by Mrs. Dueber, spent a few days here, last week.

John Schmelzer and Miss Mildred Schmelzer, Centralia, Ill., spent three days here last week.

Albert Mayer, of Joe Mayer & Bro., Seattle, Wash., stopped over here last week on his way east.

Geo. Cook, with Norris, Alister & Co., has returned with his family from a vacation in California.

Cloyd C. Dickinson, with H. W. Allen & Co., was married, March 25, to Miss Nellie Mae Iden, of Bourbon, Ind.

Sigmund Ascher, 444 Milwaukee Ave., is manager for A. Donnerstag, who is conducting business at the old place.

E. B. Wade, Galesburg, Ill., was here, last week, on his way home from Canada, where he is interested in real estate.

Aug. Bruder, Fort Wayne, Ind., was here, last week, ordering new fixtures for his store, which will be entirely remodeled.

Petz & Thiry, Detroit, Mich., were here last week replenishing their stock for an auction sale, which they will soon hold.

The engagement is announced of "Joe" Finn and Miss Merta Wakefield. Mr. Finn is a popular diamond buyer for Loftis Bros. & Co.

The Paris edition of the New York Herald, March 11, contains the name of Anthony Serewicz as among the distinguished arrivals.

Harry Saltzman, of Jenkins & Saltzman, El Paso, Ill., was here last week. Mr. Saltzman will be married in June to a Pueblo, Colo., girl.

R. H. Faris, formerly with W. E. Lee, Corning, Ia., was here, last week, buying stock for the new store which he is opening at Winfield, Ia.

There is no equity in the estate of B. T. T. T., retail jeweler at 473 Ogden Ave., who filed a voluntary petition in bank-

ruptcy, ten weeks ago, with liabilities of \$1,986.

Aug. J. Holdorf, a retail jeweler at 1040 Lincoln Ave., has bought the property at 1018 Lincoln Ave., and will remove to his new premises, May 1.

E. D. Buell, O. W. Wallis and H. A. Båby, appraisers of the estate of the Madison-Steele Co., have been awarded \$50 each for their services.

Herman J. Willer, with Wm. A. Rogers, Ltd., made a sad journey to Quincy, Ill., last week, to attend the funeral of his father, who died in that city.

Frank S. Fischer, Danville, Ill., was here, last week. Mr. Fischer has moved into his new store. All the fixtures are new and the store is one of the finest in the State.

Emil Hahn, jewelry buyer for Webb & Schwekes, Reidsburg, Wis., was here last week. Webb & Schweke's house sold out to the Stolte, Dangel & Foss Co.

Hatowsky & Newburger, 268 W. 12th St., have dissolved their partnership. After May 1, Boas Hatowski will conduct a jobbing jewelry business, exclusively.

M. L. Jalonack is holding an auction sale for Saul Klein, Greenville, Miss. H. E. Glendore, of Jalonack & Glendore, is selling out the store of F. B. Tinker, 590 E. 43d St., this city.

The case of Max Marcus, doing business as Max Marcus & Co., has been specially referred to Referee Wean. Wm. F. Zibell has been appointed receiver under a bond of \$3,000. The latter states that the accounts receivable amount to \$4,660.

Hugo Oppenheimer, of Hirsch & Oppenheimer, sails for Europe on April 9 on the *Amerika* for a three months' trip to Germany, France, Belgium, Switzerland and England. He will combine business and pleasure.

A meeting of the creditors of Henry Schmieding, a retail jeweler at 238 E. North Ave., was held last Friday. The creditors agreed to accept 25 cents cash and the balance on notes as follows: 10 cents, Sept. 15, 1908; 15 cents, June 10, 1909, and 25 cents, June 10, 1910. The liabilities are \$4,400.

No examination of the affairs of Jos. Brown & Co., was held, last week. It is thought that this week will wind up the examinations. B. Schuette, W. M. Hathorn and S. C. Cutler have been appointed appraisers of the estate. The bankrupt has been ordered by the court to file his schedules.

Among the buyers in town, last week, were: G. M. La Pierre, Niles, Mich.; Alfred C. Wortley, Kalamazoo, Mich.; Henry Wiegand, Racine, Wis.; E. J. Ballard, Evansville, Wis.; Dan S. Jones, Independence, Ia.; T. McKinney, Hutchinson, Kan.; L. J. Crawford, Burlington, Wis.; W. G. Wherritt, Mount Carroll, Ill.

The assets of the bankrupt estate of the Madson-Steele Co., bankrupts, has been sold to J. W. Clark, proprietor of Moore & Evans, for \$14,000. The liabilities of the corporation are \$30,000. Mr. Clark says he will conduct the business as a separate enterprise in its present quarters in the Masonic Temple. Martin Madson will not be connected with this enterprise in the future.

A petition in involuntary bankruptcy has been filed against Conrad Heegn, Jr., retail jeweler, at 11208 Michigan Ave. The petitioners are: Rettig, Hess & Madsen, \$387; Despres, Bridges & Noel, \$110, and Wm. L. Gilbert Clock Co., \$51. They alleged that Heegn, while insolvent, paid C. T. Wettstein & Co., and others, some money with a view to preferring them above other creditors. The American Trust & Savings Bank was appointed receiver under a bond of \$1,000.

The police of this city are still hunting for John A. Hope, who, as told in THE CIRCULAR-WEEKLY March 11, skipped out from this city after getting a quantity of jewelry from local houses on memorandum. Hope, who had for many years been employed by the Jewelers' Board of Trade, is about 40 years old, is 5 feet 9 inches high and weighs about 150 pounds; has a dark complexion, black hair tinged with gray, and a black mustache tinged with gray, which he keeps cropped short. There is a reward of \$300 now offered for his arrest. Members of the trade who may know of his whereabouts should communicate direct with P. D. O'Brien, Captain commanding the detective bureau.

O. Harris, a jeweler of Warren, Ark., was killed in Arkansas City, Ark., March 10, while attempting to stop a fight. It is alleged that several men were engaged in a brawl at Arkansas City, and that Mr. Harris attempted to bring about peace, with the result that an artery in his leg was severed by one of the combatants. The jeweler is reported to have bled to death within a few minutes. Many believe that the cutting of Harris was accidental.

GET AFTER THE BUSINESS

THAT WOULD OTHERWISE GO TO YOUR COMPETITOR,

WITH AN ARTISTIC HIGH-GRADE CATALOG

Containing from 36 to 200 Pages and over, and arranged to meet your local conditions

(Copy of letter.)

Hamilton, Ohio, Jan. 17th, 1908.

The Arnstine Bros. Company,
Cleveland, Ohio.

Gentlemen:—

In reply to yours of the 15th inst., I beg to write you that the Catalog you made for us was a very satisfactory book and acted as an excellent salesman. They increased our Holiday trade a large percentage over any previous year. Our competitors complained bitterly in regard to falling off of sales due to the panic.

This section is flooded with about all the Catalogs sent out by the large mail order houses, and your Catalog is the only stumbling block that can be put in their way.

The book you made for me last year is the fourth one, and is a great improvement over the one the year before.

Trusting that this letter will be of service to you, I remain,

Respectfully,

A. Seidensticker.



STORE OF A. SEIDENSTICKER, HAMILTON, OHIO

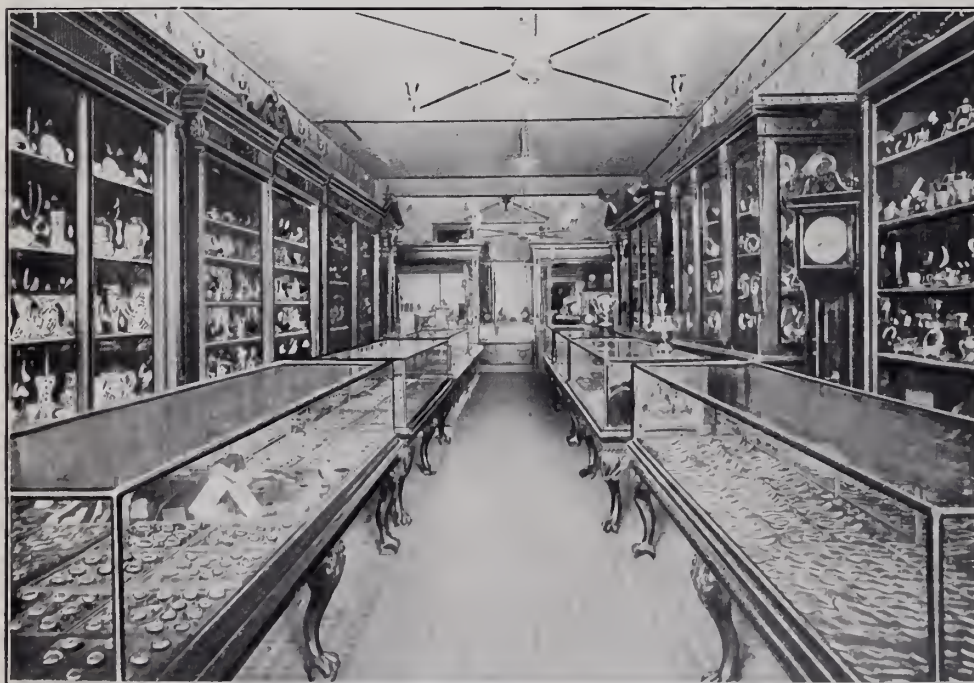

STORE OF R. B. ANGER & CO., OSHKOSH, WIS.

If you are interested, and will notify us, our representative will take pleasure in calling on you and explaining our method.

THE ARNSTINE BROS. COMPANY

Originators of Our Exclusive Catalog Method for the Retail Jeweler

CLEVELAND, OHIO

IN WRITING US PLEASE MENTION THIS ISSUE "JEWELERS' CIRCULAR-WEEKLY"

Write us at once for Samples
and Particulars, FREE

(Copy of letter.)

Oshkosh, Wis., Jan. 17th, 1908.

The Arnstine Bros. Company,
Cleveland, Ohio.

Gentlemen:—

Replying to yours of the 15th inst., will say that we've had a very successful year. Your Catalog was a fine creation, and in connection with the Circulars brought our name before the people so effectively that it was only certain that we would have a prosperous Christmas trade.

Respectfully,

R. B. Anger & Co.

Our representatives visit nearly
every State in the Union

Cincinnati.

G. B. Colles, Rockwood, Tenn., has sold his business to Bagby & Harris, of that locality.

Charles E. Payne, of L. Gutmann & Sons, left, last week, on his regular northern business trip.

A. Strauss, of D. Jacobs & Co., will leave, next week, on a business trip through northern Illinois.

Henry Rabe, formerly of L. Gutmann & Sons, after April 1, will be associated with the Oskamp, Nolting Co.

A. A. Spiegel, of A. A. Spiegel & Co., and wife celebrated their fifth wedding anniversary at their home, March 31.

Word was received by Cincinnati creditors that William Steiner, Beckley, W. Va., had recently gone into bankruptcy.

Otto Mehmert, with Joseph Mehmert, has returned from his business trip on account of illness. Joseph Mehmert will finish the trip.

The Miller Jewelry Co. has received the contract to make the gold medals for the boxing contest next month at the Cincinnati Gymnasium.

Friends here in the trade regret very much to hear of the death of the father of John Robinson, Mt. Sterling, Ky., who recently passed away at Carey, O.

B. S. Newiman, of Frohman & Co., leaves his week on his regular business trip. On April 24 he and his wife have arranged to leave here for a two months' trip in Europe.

Samuel Kahn, Jr., of the Eclipse Jewelry Co., has resumed business duties after a three months' vacation in Birmingham, Ala., and will leave, this week, on a business trip west.

Aaron Plaut, of A. & J. Plaut, and his wife leave, this week, for a sojourn at Atlantic City, after which they will leave for New York to meet their daughter, now a student at Vassar College.

Charles E. Levi, 509 Vine St., after April 1, will retire from business and will then devote the greater part of his time to traveling. He is now planning to leave on a European tour in a month or so.

Samuel McCollum, Cedarville, O., has bought out the business of E. J. Harrison & Co., at Jamestown, O., and will continue at that place. Mr. Harrison contemplates opening a store in Texas in the near future.

The new partners controlling the Henry Arenberg business, which has been run as a loan concern since the change in the management a few months ago, have had a disagreement. The partnership is composed of Mrs. Arenberg and Benjamin Goldberg, and a receiver has been applied for by Mrs. Arenberg.

The Cincinnati Retail Jewelers' Association held a regular meeting, March 27, when matters pertaining to the convention were taken up. The main subject, the "exhibits," received much consideration, and it is expected that arrangements will be made looking to an extensive jewelry exhibition during the convention.

Out-of-town jewelers here the past week purchasing goods included: John W. Jones and wife, Mt. Sterling, Ky.; Mr. Wines, of White & Wines, Richmond, Ky.; J. Glascock, of Williamstown, Ky.; George J. Linck, Canton, O.; Theodore W. Witt, Versailles,

Ky.; P. W. Starks, Manchester, O.; D. A. Lamb, Wilmington, O.; J. D. Ward, Rising Sun, Ind.; E. Mueller, Charles Martin and Charles Mikessil, Hamilton, O.; Albert Zoellner, Portsmouth, O.; H. C. Reed, Blanchester, O., and O. O. McCracken, Mt. Olivet, Ky.

A well-dressed woman called at the Duhme Jewelry Co.'s store, last week, and while pretending to purchase a \$600 diamond ring placed two other rings on her finger. She decided to take the \$600 ring, and paid the salesman \$10 down, giving her address as the St. Nicholas Hotel. She was about to leave the store when she was reminded of the other two rings on her fingers, and smilingly remarked she had forgotten to remove them. The rings were handed over and the woman departed without claiming the \$10 she had left on deposit, and investigation showed she was not known at the St. Nicholas Hotel.

Jacob Buchan, a diamond cutter, recently received judgment of \$10.50 against the Duhme Jewelry Co. for one week's pay. The suit, which involves an important principle, will be appealed. Buchan testified, before Squire Muller, March 23, that until March 10 he was employed as a cutter and polisher for this house, and that after returning from his lunch that day three of seven stones on which he had been working were missing. The management, he said, had the diamond cutting force searched, but there was no trace of the stones. He then applied for his wages, but claimed the demand was refused. Oscar Keck, president of the Herman Keck Mfg. Co., states that the diamond cutters of their factory agreed to be responsible for work in their hands, and also says Buchan did not report on the loss of the gems until two hours after they were missed. The case, he states, will be taken up on appeal.

James Holland, of the John Holland Gold Pen Co., has returned from Chicago, whither he and his mother were summoned owing to the sudden illness of John Holland, Sr. Mr. Holland was stricken March 26 with apoplexy while chatting with friends at the Auditorium Annex Hotel, where he was stopping. The news of his illness came as a shock to his friends here, as he apparently was in good health and had been so during his stay in Chicago. Mrs. Holland has remained with her husband, who, it is hoped, will soon be able to return to Cincinnati. Shortly after the news of Mr. Holland's illness reached Cincinnati, and just as his wife and son were on their way to the station to leave for Chicago an alarm of fire was sounded and the fire proved to be located in the John Holland Gold Pen Co.'s factory. The damage done, which is mostly from water, will probably not exceed \$500. The fire was caused by the crossing of the electric wire underneath the flooring between the third and fourth stories, thus igniting the woodwork and entirely destroying the large wooden stairway between those floors. Operations in the factory have been suspended for a short time until the necessary repairs can be made.

The frame building occupied by L. P. H. Hatch and the Scott Co., Goodland, Kans., was badly damaged by fire recently.

Cleveland.

Frank H. Pitkin and wife, Andover, O., were here, last week.

Jas. Jenks, of Scribner & Loehr Co., has started out on his usual Spring trip.

Walter King, of the Julius King Optical Co., visited the Cleveland office this week.

Sales Manager Loeb, of the Dueber-Hampden Watch companies, was in the city, Friday.

Chas. Ettinger has sold the lease on his Erie St. store and will discontinue it after April 1.

Mr. Montgomery, of the Pittsburg office of M. A. Mead & Co., was a visitor to Cleveland, recently.

Knittle & Longtin, 1929 W. 25th St., were robbed of several hundred dollars' worth of gold and silver jewelry, last week.

J. H. Heiman is just back from a pleasure trip to Montreal. A serious fall on the ice, some weeks ago, made it necessary for Mr. Heiman to take a vacation.

There is a very interesting display of jewelry, enamel, silverware and pottery at

Cleveland School of Art, in charge of the Decorative Art Club of Cleveland.

H. W. Arnstine and A. L. Davis, of the Arnstine Bros. Co., are great automobilists. Mr. Arnstine just received his new electric Limousine and Mr. Davis his new Oldsmobile.

Letters have been received by the trade from the Detroit Jewelers' Board of Trade, looking to the formation of an association among jobbers and manufacturers of this city.

In an open letter to the editor of the *Cleveland Leader*, Capt. R. A. Burdick denied the published reports that diamonds will be lower and gives specific reasons why, of necessity, prices will be maintained.

B. V. Arnstine, in the east; A. E. Arnstine, from the south, and J. P. Wells are all reporting excellent business to the Arnstine Bros. Co. They say the trade generally is in a very optimistic frame of mind.

The Brunner Bros. Co. is the originator of a specialty known as the "Baseball Fan Souvenir," a badge which is extensively used at the opening games. The firm furnished all the buttons and souvenir badges for the recent State Masonic Consistory gathering.

The local police are under the impression that a very young girl was implicated in the robbery of Knittle & Longtin's jewelry store in W. 25th St. recently, because the detectives found prints of a girl's shoe at the rear entrance and in the dust on the roof and shed which adjoined the building. But few things were stolen at the time of the robbery, among them a silver curling iron, a manicure set and an ornamental comb.

The following jewelers were in this city during the past week: Mrs. F. R. Montgomery, Sandusky, O.; A. E. Kintner, Painesville, O.; Z. W. Miller, Trail, O.; Walter Deuble, Canton, O.; Albert Meseke, Oberlin, O.; Wm. Kutz, Bellevue, O.; Frank Dyer, Caro, Mich.; W. Moore, Newcomerstown, O.; Gunther & Karshner, Bellevue, O.; H. H. Brainerd, Medina, O.; Herman Wight, of J. H. Wight & Sons, Wellington, O.

The Only Manufacturers in the Line Selling Only to Retail Jewelers Direct

SOLD WITH
PROFIT BY
THE RETAIL
JEWELER.

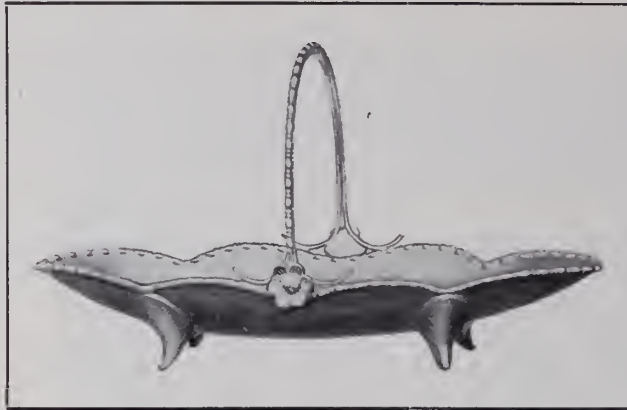

IF YOU HAVEN'T
SEEN OUR
LINE, WRITE
AND ONE OF
OUR SALES-
MEN WILL
CALL.

Rockford Silver Plate Co. ROCKFORD, ILL.

"Stand By Those Who Stand By You"

WE PROTECT EVERY RETAILER OF ROCKFORD GOODS



L. Robins, Oswego, N. Y.
Blumberg Brothers, Syracuse, N. Y.
Sun Fat Company, San Francisco, Cal.
Peter Engel, Marysville, Cal.
S. Hollander, Salinas, Cal.
A. P. Hall, Visalia, Cal.
M. Edwards, Syracuse, N. Y.
C. Wilcoxson, Carnegie, Pa.
Keystone Jewelry Co., Pittsburg, Pa.
E. A. Walker, Pasadena, Cal.
S. E. Rich, San Jose, Cal.
Andrews & Wood, Modesto, Cal.
A. Thurman, Healdsburg, Cal.
J. Frost & Co., Chicago, Ill.
A. Clark, Spencer, Ind.
C. Hill, Southbridge, Mass.
U. S. Renshaw, Lansford, Pa.
L. M. Lasell, Martinez, Cal.
E. F. Brown, Pasadena, Cal.
J. Hyman, Sacramento, Cal.

H. J. HOOPER

NEW YORK'S LEADING JEWELRY AUCTIONEER—Write him for
Testimonials that cannot be equaled by any Auctioneer in New York

37 MAIDEN LANE, NEW YORK CITY

The names that I publish below are merchants I have sold for direct; there are no wholesalers among them.
Anyone wanting the wholesalers I have sold for indirectly, I will furnish by mail.

Kohn Brothers, Missoula, Montana.
F. R. Stearns, 2 sales, Petaluma, Cal.
Ike Fields, Grass Valley, Cal.
George Johnson, San Bernardino, Cal.
R. F. Stearns, Stockton, Cal.
Thomas Howard, Marshfield, Oregon.
Franz Mahncke, Tacoma, Wash.
J. H. Shade, Brooklyn, N. Y.
John E. Knapp & Co., Salt Lake City, Utah.
James J. Tracey, Seattle, Wash.
Charles Hoff, Denver, Colo.
E. A. Walker, Pasadena, Cal.
R. Cohen, Pittsburg, Pa.
F. R. Williams, Buffalo, N. Y.
R. W. Wilson, Portland, Oregon.
Fred Woodman, Louisville, Ky.
M. Rundbaek & Co., Chicago, Ill.
Glendemann & Schweitzer, San Francisco, Cal.
Luke MacDonald, Visalia, Cal.
Bemas Brothers, Vallejo, Cal.
A. Tucker, Newport News, Va.
J. Luxenberg, Patton, Pa.
A. Lison, Kingston, Pa.
M. C. Khuner, Auburn, N. Y.
Everett Jewelry Co., 3 sales, Everett, Wash.
W. D. Mcail, Marysville, Cal.
J. Joseph, Los Angeles, Cal.
A. Leibson, Duryea, Pa.
Davidow Brothers, 3 sales, Wilkesbarre, Pa.
Maiden Lane Jewelry Co., Elizabeth, N. J.
Dualibil Brothers, Schenectady, N. Y.
Fred. Ward, Visalia, Cal.
H. E. Gilbert & Sons, Modesto, Cal.
M. L. Stanton, Riverside, Cal.
A. E. Backs, Woodland, Cal.
M. S. Osgood, San Jose, Cal.
Chas. Wilcoxson, Napa, Cal.
George Jordan, Redlawn, Cal.
George Thomas, Auburn, Cal.
W. H. Wilson, Merced, Cal.
South Bend Jewelry Co., South Bend, Wash.
B. Banetti, Ferndale, Cal.
D. E. Gilbert, Modesto, Cal.
M. Barboska, Santa Cruz, Cal.
L. Robins, Utica, N. Y.
Yoshimi & Co., Atlantic City, N. J.
Cummings & Son, San Francisco, Cal.
J. M. Ives, Meriden, Conn.
E. H. Kutner, Albany, N. Y.
S. Susman, Stamford, Conn.
Rival Jewelry Company, Los Angeles, Cal.
A. H. Broom, Boise City, Idaho.
Levison Brothers, Oakland, Cal.
O. A. Dockhan, N. Tonawanda, N. Y.
A. Benjamin, Denver, Colo.
M. BasBarker, Fresno, Cal.
J. M. Dickson, Stockton, Cal.
J. M. Jacobsen, Ferndale, Cal.
J. Rupert, Tererunt, Pa.
C. O. Biederman, Oneonta, N. Y.
Freeman Jewelry Co., Niagara Falls, N. Y.
Arritt & Co., Newport News, Va.
T. J. Routledge, Elmira, N. Y.
Rosenblatt & Co., Greenville, Tenn.
M. Marter, Cottage City, Mass.
J. F. Rockwell, Port Jervis, N. Y.
J. M. Frear, Binghamton, N. Y.
Palace Jewelry Co., Auburn, N. Y.
J. Luxenberg, Hertzdale, Pa.
H. Hedges, Fairmount, W. Va.
A. E. Morro, Los Angeles, Cal.
A. B. McKelvey, Pasadena, Cal.
Bogart & Page, Binghamton, N. Y.
A. F. Redfoot, Mt. Jewett, Pa.

I have just closed a very successful sale of the W. W. Appel stock at Lancaster, Pa. It will pay you to write to Mr. Appel or Wm. R. Briniou, attorney for Board of Trade, 124 E. King St., Lancaster, or First National Bank of Lancaster.

Los Angeles.

The Southwest Turquoise Co., 113 N. Broadway, will open a retail branch store at 531 S. Spring St., on April 1.

Benjamin C. Crandall, representing several factory lines, has returned from a trip through the central portion of the State.

The J. C. Fleming Co. has concluded its stock-reducing and inventory sale, and is again conducting business in the regular way.

J. W. Crogan has bought out the interest of Mr. Picou in the jewelry manufacturing business recently conducted by James & Co., 342 S. Broadway.

Leonard S. Lee, of Gilmore & Lee, is making a business trip through southern California, including San Bernardino, Redlands, Riverside and Pomona.

A movement has been started to have all jewelry jobbers close at 5.30 p. m. during the entire year. Such a movement was undertaken last year, but failed.

The J. P. Trafton Co., now settled in its new store on S. Broadway, has added to its clock department a large assortment of cuckoo, chime and musical clocks.

George F. Hambright, of Hambright & Walsh, has returned from a trip through the southern part of the State. He reports a gradual improvement in business.

Philip Klein, who has been doing business at 219½ W. 4th St., is preparing to remove about May 1 to 445 S. Spring St., where a handsome new store is being prepared for him.

A petition will shortly be circulated among wholesale jewelers here, requesting them to close their places of business at 1 p. m. on Saturdays during May, June and July.

Manager Burger, with T. B. Clark, announces that he will at once begin another auction sale in order to dispose of the balance of his stock so that he can retire from business.

Rayburn Clark Smith, of Geo. W. Smith & Co., who have the contract for supplying the fixtures for the new Montgomery Bros. store, corner of 4th St. and Broadway, was in this city last week.

F. C. Dukeman, formerly in the employ of the J. P. Trafton Co., but now conducting a diamond business on his own account in the O. T. Johnson building, is the happy father of an eight-pound boy.

Percy H. Greer returned recently from Oakland, where he sold the stock of B. Lissner. He intends to leave, March 30, for Stockton, Cal., to take charge of the sale of the stock of H. J. Kuechler.

R. A. Moore, Santa Barbara; Ernest Pollock, of Pollock Bros., Riverside; H. H. Hooper, Whittier, and C. P. Kryhl, Santa Ana, have been in this city the past week calling on the wholesale jewelers.

E. B. Sherman, a jeweler whose home is at Grayslake, Ill., has, with his wife, been here for some time touring through this section. He has been so favorably impressed with Los Angeles that he contemplates locating here.

J. G. Donovan & Co. have signed a contract with Montgomery Bros. definitely fixing the date of the former company's taking possession of the present store of Montgomery Bros. on Nov. 1. Mr. Donovan

expects to be fully settled in time for the holiday trade.

F. A. Marcher, of the Pacific Gem Co., when alighting from a street car a few days ago, fell and injured himself so severely that he was confined to his bed for several days. One knee was severely sprained, and it is probable that it will be some time before he fully recovers.

Jacob Macowsky, of the Angelus Jewelry Co., will, in September, open a store in the Phelan building, San Francisco, the same place in which he was doing business at the time of the earthquake and fire. He is now in San Francisco attending to some details of preparing the new store for his occupancy. It is understood that he will continue his business here on Spring St.

Two blue-white diamonds worth \$175 were stolen recently from the Thos. B. Clark store, 351 S. Spring St. Two men and a woman entered the store and were being shown a tray of stones by Manager Burger. His attention was diverted for a moment, and when he again observed the tray he was convinced, but not positive, that some of the stones had been taken. The supposed customers left without buying. He sent a salesman to follow them when they left the store, but they immediately separated and then were lost in the crowds on the street.

A burglar broke a plate-glass window in the store of Henry B. Crouch, corner of Broadway and Mercantile Pl., at 2.30 A. M., a few days ago, and got away with jewelry valued at about \$300. The store was fitted with a burglar alarm, and two officers were on hand within three minutes after the glass was broken, but the burglar had escaped. They found a few pieces of jewelry near the store on the sidewalk and a tray taken from the window was discovered in Mercantile Pl., less than a block away. The burglar had undertaken to cut a large hole through the window with a diamond, intending probably to avoid, in this manner, setting off the alarm, but the glass apparently broke and fell inside the window. He then grabbed a number of brooches, pendants and necklaces and escaped. Mr. Crouch had no insurance to cover the loss, either of the jewelry or of the window.

Milwaukee.

W. J. Graff, Boscobel, Wis., has purchased the stock of M. M. Huck, Kenosha, Wis., who went into bankruptcy.

It is reported that Max Schucht, 1509 Vliet St., has offered to compromise the claims of his creditors on a basis of 35 per cent. A meeting of the creditors has been called to consider the offer.

Louis M. Esser stated recently that the price of diamonds is more likely to advance than to decline, as had been reported. He characterizes the talk of a break in the diamond market as solely newspaper talk. He said: "It is practically impossible for a drop to occur at this time, and this condition will obtain as long as the diamond importers in New York are the middlemen between the producers and the dealers."

B. F. Kessler, Mount Carmel, Pa., has been elected treasurer of the recently founded Option Club.

Detroit.

W. A. Sherwood, Dundee, was in town, last Thursday.

O. F. Kleckner, Milan, was a visitor in this market, last week.

W. F. King, Jr., Adrian, was in this city, recently, on business.

Roy W. Wagner, Toledo, O., was a recent visitor in this market.

H. L. Parker and wife, Dryden, were here, recently, for a few days.

George Chambers, of the Chambers & Stewart Co., Mount Clemens, has returned from a vacation trip to Florida.

W. A. Sturgeon & Co. have announced an auction sale, beginning April 6, to close out the remainder of their stock.

The show window in the store of Traub Bros., 118 Woodward avenue, was broken, last week, by a thief who escaped with \$200 worth of stock.

F. P. Mathauer, of Mathauer & Koester, has returned from his wedding journey and has been out on the road since. He is in Ohio this week.

Mrs. Jennings, wife of Max Jennings, St. Clair, was here, recently, and spent some time at Ann Arbor, last week, attending the State Congregational Church convention.

H. P. Shane, Bancroft, who is a telephone man as well as a jeweler, was in Detroit, last week, attending the convention of the Independent 'phone companies at the Hotel Pontchartrain. Incidentally he called on his friends in the trade.

Roy C. Brabb, of W. A. Sturgeon & Co., returned, last Friday, from Florida, where he spent a couple of months. He took in the yacht races at Palm Beach and had the pleasure of seeing his friend, E. R. Walker, carry off four cups with his motor boat *General*. Marvel I. Brabb is still in the south.

Omaha.

L. E. Griffith & Co. have installed new fixtures in their store.

Albert Edholm was initiated, last week, in the Mystic Shriners.

Warren M. de Camp, with Henry Copley, has returned from a visit with his parents at Shenandoah, Ia.

Miss Emma Quinn, buyer for the Mawhinney & Ryan Co., was called to South Amaba, last week, owing to the illness of her sister.

Fred Brodegaard & Co. have engaged A. Nelson, formerly of Rockwell, Ia., as watchmaker and optician, to take charge of these two departments.

L. A. Borsheim, Sr., has purchased lots at Sulphur Springs, Ark., and will erect a business block. He contemplates opening a branch jewelry store there shortly.

A check from the American Bonding Co., Baltimore, was received, last week, by L. A. Borsheim, as a full reimbursement for the loss by burglary which occurred at his store, several months ago.

H. S. Bostock, Culbertson, Nebr.; S. E. Howard, Hastings, Nebr.; W. B. Graves, Elkhorn, Nebr.; Frank Folsom, Ashland, Nebr.; Hans Johnson, Hamlin, Ia., were in this city, during the past week, replenishing their stock.

SWARTCHILD & COMPANY

HEYWORTH BUILDING

CHICAGO

The Largest Exclusive Jewelers' Supply House in the World



NEW GAS SOLDERING TOOL

Copper, which is continually over the flame, is adjustable.

FITTED WITH STOP-COCK

Tool is 9 inches long and is made with Wood Handle and Brass Trimmings.

No. D 19. Tool 9 inches, copper length, 1 1/4 inches, each - \$1.75
 " D 20. " 9 " " " 2 1/4 " " " - 2.00

Every Jeweler must appreciate the practicability of this tool.

The Genuine HOLD=ON

SCARF PIN PROTECTORS

AT A REDUCED PRICE \$2.50
 No. 78000 Per Dozen

If you have not a copy of our double-sized, 440-page Catalogue, write at once. Sent gratis upon application.



Pat. May 20, '02

WM. C. PENFOLD CO.

No. 35 MAIDEN LANE, NEW YORK

LARGEST EXCLUSIVE WATCH JOBBERS IN NEW YORK OF

Dueber-Hampden Watches Dueber Cases—Hampden Movements

A Complete Line Always on Hand. Mail Us Your Orders



AN EXAMPLE OF A GREAT ACHIEVEMENT IN THE MANUFACTURE OF IMPORTED WATCHES IS EVIDENCED IN

"Tavannes" Movements and "Cyma" Watches

WHY?

Because all features heretofore existing that have been an obstacle to the modern watchmaker have been eliminated—being brought about by the introduction of automatic machinery in the manufacture of these goods, and the concentration of our mammoth factory on a modern scale, enabling us to furnish "FINISHED MATERIAL" ready to use.

"TAVANNES" movements and "CYMA" watches give most satisfactory results when exposed to the extreme influence of TEMPERATURE, ELECTRICITY or MAGNETISM.



TAVANNES WATCH COMPANY

131 Wabash Avenue
 Chicago

ADOLPHE SCHWOB, Sole Agent for the U. S.
 2 and 4 MAIDEN LANE, NEW YORK

704 Market Street
 San Francisco

San Francisco.

The California Optical Co. expects to occupy its new building at the corner of Post St. and Grant Ave., about June 1.

The Berteling Optical Co. has secured a store at the corner of Geary and Stockton Sts., and will move in about four months.

The store of J. Newman, at 1365 Golden Gate Ave., was entered by a burglar last week. Over \$500 worth of stock was taken.

The two baseball teams formed among the jobbers of the north and the south sides of Market St., respectively, held their first game last Saturday. The south side team won, with a score of 20 to 13.

R. Bujannoff, whose store at 51 Lick Pl., in the Lick building, was well known for many years, has secured the same old location. Since the fire Mr. Bujannoff has carried on the business at his home, 1711 Broderick St.

J. E. Paulsen, a salesman employed by Peter Johnson & Co., at their new Fillmore St. store, was held up and robbed last Thursday night by three armed footpads. They stole two gold watches valued at \$200, a stickpin and some cash.

J. Makrowsky, formerly of this city, but for the last two years with the Angelus Jewelry Co., Los Angeles, has secured his old location in the Phelan building, on Market St., near O'Farrell St., and will open a store there as soon as the building is finished, which he believes will be in September.

Among the jewelers who visited San Francisco last week were: Albert Hanson, Seattle, Wash.; Mr. Cummings, Monterey, Cal.; J. R. Dunlap, Amador, Cal.; Mr. Wachhorst, Sacramento, Cal.; A. B. Wilson, Martinez, Cal.; B. O. King, Santa Rosa, Cal.; H. Mathieu, Rawhide, Nev.; Chas. Haas, Stockton, Cal.

J. Edward Boeck, wanted in New York for the theft of \$250,000 worth of goods about a year ago, and who was arrested here recently, has for some time been in the Nevada mining camps, under the name of J. E. Burke. He was arrested on information furnished by W. H. Seaman, Goldfield, Nev.

Several packages containing 155 pearls, valued at \$9,236.07, were declared forfeited to the United States Government, on Tuesday afternoon of last week, by a jury in the United States District Court. The verdict was rendered because the pearls had been smuggled into the country by Manuel L. Cornejo. The latter has disappeared, and his bail of \$4,000 will be forfeited. He was arrested while attempting to sell some of the pearls to the W. K. Vander-slice Co. The pearls will be sold at public auction as soon as the legal papers are made out and the necessary advertising done.

Hirsch & Kaiser moved into their permanent downtown store at 218 Post St., adjoining the Shreve building, last week. The store is a large one, about half a block in depth, and the company occupies the first and third floors. The rear is taken up with a large manufacturing department. The store itself is finely appointed with every convenience for customers. The woodwork of the store is the first example seen in San Francisco of Mexican jenseiro wood, and has attracted much attention.

The installation of the machinery is not yet complete, but in a short time the store will be equipped with all the most improved devices in optical machinery.

Minneapolis and St. Paul.

Cohen Bros. have opened their new store at 112 Nicollet Ave., Minneapolis.

Max Witebski, Washington Ave., N., near First Ave., Minneapolis, has asked creditors for an extension.

John Miller, Columbus, N. Dak., has discontinued business. He was in the Twin Cities, last week, on his way to Iowa.

Morris Heffron, engaged in business at E. 3d St., St. Paul, and Miss Fannie Eppstein, Minneapolis, were recently united in marriage.

M. Weinstein, Webster, S. Dak.; A. L. Mealey, Delano, Minn., and Paul Hunziker, Jordan, Minn., were recent visitors in the Twin Cities.

T. J. Thompson, Barron, Wis., with stores in several neighboring towns, was in the Twin Cities, attending a Masonic meeting, last week.

Frank Bradley, aged 21, was arrested about a week ago, at his home in St. Paul, accused of attempting to pass a forged check for \$22.50 at a jewelry store. The check was made out in favor of James Ryan and was signed by J. K. Kebbe.

Win. Hope, St. Croix Falls, Wis., has petitioned the Probate Court of St. Paul that letters of administration be issued to John Mailer on the estate of the late Lawrence Hope, formerly of 242 E. 7th St., St. Paul, whose death was chronicled in the last issue of THE CIRCULAR-WEEKLY. The estate consists of personal property worth \$2,500 and real property of the same value.

A Minneapolis daily newspaper gave considerable publicity to the statement that diamonds were about to decline and were already lower, which prompted the publication of a statement signed by J. B. Hudson, of J. B. Hudson & Son, S. Jacobs & Co., White & MacNaught, H. F. Legg & Co., Eustis Bros., and the American Jewelry Co., declaring that prices were not lower, nor were they inclined to go lower. Mr. Hudson stated that his firm would guarantee any purchaser against loss from a reduction in price. Following this statement was a republication of the article in THE JEWELERS' CIRCULAR-WEEKLY, of March 18, headed "Diamond Market in No Danger." Appended were cablegrams from London, from the Diamond Syndicate, and from the Premier Mining Co., of London, declaring that prices would be maintained.

Bennett & Quinn, Waterloo, Ia., adjudged bankrupts, with liabilities of \$5,000, are selling their stock at private sale. F. S. Merriau has charge for the creditors.

The first meeting of the creditors of J. S. Anderson, formerly engaged in the jewelry business at 375 Main St., Worcester, Mass., was held, March 19, in the office of Referee in Bankruptcy Chas. F. Aldrich, in the State Mutual building. Walter J. Kent was appointed trustee under bonds of \$2,000. The debtor was sworn and examined and the meeting adjourned until June 14.

Indianapolis.

TRADE CONDITIONS.

Local dealers say that the coming Easter trade promises to be good and are anticipating a large trade in souvenir spoons and small silver novelties. Trade has been dull during Lent and the first quarter of 1908 has been very unsatisfactory to the retail trade. Manufacturers and wholesalers say they are having a good business, although it will not reach the amount done during the first quarter of 1907.

L. Markowitz, of the I. Groh's Jewelry Co., has gone to Texas on a two months' business trip.

While not yet out of danger, F. L. Bryant, who has been seriously ill, is said to be slowly improving with hopes of ultimate recovery.

I. Groh, president of the I. Groh's Jewelry Co., made a business trip through Central Indiana, last week, and reports that business conditions are improving rapidly.

George Gannon, a watchmaker, employed by T. M. Jackson, Seymour, spent part of last week visiting relatives and friends in this city, and renewing old acquaintances.

Among out-of-town jewelers in this city, last week, were: J. E. Steinkamp, Jasper; J. E. Johnson, Anderson; G. V. Brown, Flora; J. B. Johnson, Goodland, and L. N. Hogatt, Herbst.

Ralph B. Clark, Anderson, president of the Indiana Retail Merchants' Association, addressed the Indianapolis Retail Jewelers Association at the Commercial Club, Monday evening.

Business men at Columbus have organized the Commercial Club to promote commercial and manufacturing interests. H. L. Rost, a retail jeweler, has been elected one of the directors.

J. W. Hudson, Fortville, has added a line of pianos to his stock and now bears the distinction of being the only jeweler, the only sewing machine agent and the only piano dealer in that hustling town.

The Indianapolis Automobile Trade Association depended wholly upon local jewelers to act as timers in the various events of their annual show, last week. Carl Walk, George S. Kern, A. C. Craft, Horace A. Comstock and A. W. Gray were the timers at the hill climbing contest, while A. C. Craft was timer at the obstacle and novelty races.

Pacific Northwest.

A. F. Robinson, formerly of Portland, Ore., is now with C. A. Kramer, Independence, Ore.

L. Alva Lewis, Klamath Falls, Ore., is moving his stock into the Malone building, which he has secured for his store.

Samuel Fischer, of the firm of H. Broth & Co., 504 Main Ave., Spokane, Wash., was married recently to Miss Jennie Laske, of that city. The couple are making an extended visit to Portland, Los Angeles and San Francisco, after which they will return to Spokane.

For the second time in two weeks burglars broke into the retail jewelry store of F. E. Touse, Pioneer, O., recently, by forcing open a front door. They blew open the safe with nitroglycerine and took jewelry and watches valued at \$500. Thus far no clue has been obtained.

Warning to the Trade

"HOLD-ON" CLUTCHES

 WE are the sole and exclusive licensees for use in jewelry under Patent No. 700,412, dated May 20, 1902, granted to Max H. Fischer for Clutches. This is a broad, comprehensive patent for clutches under which patent we have manufactured and sold our "HOLD-ON" clutches for scarf pins, etc., for many years past.

We have brought suit in the United States Circuit Court for the Southern District of New York against various concerns and persons for patent infringement, unfair trade and imitation of our clutches and for FORTY THOUSAND DOLLARS (\$40,000) damages.

We have also brought suit in the same court for the infringement of said patent against another concern having lately placed another similar device on the market, and we will also bring suit against all others who make, sell or offer for sale any clutch infringing upon our patents covering the manufacture of the Hold-On Clutch.

We are informed by our counsel that the claim of these parties that their clutches are made under patents does not excuse the infringement, as they are ALL LATER than the Fischer invention.

All dealers are hereby warned that the making, selling, using or otherwise handling any of the above devices except through us, will be deemed an infringement of our rights, for which suit for infringement and damages will be immediately brought, and WORTHLESS GUARANTEES will not avail dealers who handle such goods.

It is our intention to vigorously prosecute all infringements of the patent and trade rights and to protect our rights by every means in our power.

Hold-On Clutch Company
C. P. GOLDSMITH & CO., Proprietors

N. H. White & Co.'s Team Win Championship in Jewelers' Bowling League Tournament.

Monday night at Ehler's Universal Bowling Alleys, Brooklyn, before 150 enthusiastic supporters, the final games to decide the championship in the Jewelers' Bowling League of New York were rolled by the teams representing N. H. White & Co. and Cross & Beguelin, and resulted in a victory for the N. H. White & Co. team.

The rivalry between the two contesting teams has been sharp throughout the season, and the struggle for first place has kept members of the bowling league and their friends greatly interested as to the final outcome. The N. H. White & Co. team needed one game to win the championship. The game started at 8 p. m. The Cross & Beguelin team made a strong fight, but lost the first game and the championship by a score of 862 to 841. The racket of horns and bells in the hands of the excited spectators testified to the interest shown in the outcome of the game. The last two games were won by the Cross & Beguelin team, the scores being as follows—902-862 and 827-821.

The winning team become the possessors of the bowling league championship cup. The members of the team have worked hard for victory, and are to be congratulated in their success.

In the games rolled Monday night, 11 1/2 Dillingham, of the winning team, rolled three games as follows: 236-211-215.

The members of the N. H. White & Co. team are: W. E. Ward, H. H. Dillingham, William Taylor, Jr., Nelson Peck, Norman Pearsall, C. E. Roll, Roy Pierson, Van Shotwell, C. Shaw and Frank Rathbone.

F. L. Schuster, Texarkana, Ark., Files Voluntary Petition in Bankruptcy.

TEXARKANA, Ark., March 25.—F. L. Schuster, one of the pioneer settlers of Texarkana, and for the past 30 years engaged in the jewelry business, filed a voluntary petition in bankruptcy in the United States Court Monday afternoon. The petition was immediately referred to the referee in bankruptcy, Major C. B. Moore, who appointed Will Steel receiver.

The assets of the bankrupt are estimated to be about \$1,800, over and above exemptions, and consist exclusively of the stock of goods and fixtures. The liabilities are placed at between \$4,500 and \$5,000.

Schuster, who is over 60 years old, commenced business here in 1871.

The Plumb Jewelry Store, Des Moines, Ia., has just secured a 20 years' lease of what is considered the most desirable business location at that place. The new quarters are situated in the Fleming block, Sixth Ave. and Walnut St. The store will extend from Walnut St. to the corridor through which the elevators are reached, and from this corridor there will be another entrance to the store. The workroom and storeroom will be located in the basement. An important feature of the new store will be the display windows. The firm will have 60 feet of display space on Sixth Ave. and nearly 20 feet on Walnut St.

INDEX TO ADVERTISEMENTS.

ame Comb & Novelty Co.....	38	Hedges, A. J., & Co.....	29	Randall, C. Ray	21
ams, T. W., Co.....	24	Hedges, Wm. S., & Co.....	58	Ranlett & Lowell Co.	102
lsopp Bros.	27	Heller, L., & Son.....	50	Reed & Bartou	72
lvin Mfg. Co.....	Inside front cover	Herpers Bros.	108	Reichhelm, E. P., & Co.....	108
merican Gem & Pearl Co.....	60	Hill & Schmidt	31	Relchman, A.	62
merican Platinum Works.....	108	Himalaya Mining Co.....	62	Renziehausen, W. F., & Co.....	114
merican Watch Case Co.....	102	Hirsh & Hyman	56	Revell, A. H., & Co.....	116
rchibald-Klement Co.	30	Hodenpyl & Walker	54	Richards, J. M.	60
rlzona Turquoise Mines Co.....	50	Hoffman Novelty Co.	108	Richards, W. E., Co.....	36
rnstein Bros. & Co.....	46	Hold-On Clutch Co.....	84	Richardson, Enos, & Co.....	26
rustline Bros. Co.....	78	Hooper, H. J.	80	Robbins, Chas. M., Co.....	32
ustin, John, & Son.....	115	Hotel St. James	112	Rockford Silver Plate Co.....	80
verbeck, M. J.	23	Hraba, Louis W.	110	Roger Williams Silver Co.....	34
agg & Co.	56	Hyde & Co.	33	Rohrbeck, John E.	30
aker, Geo. M.	108	Illinois Watch Co.	76	Roseman, A.	56
all, Webb C., Watch Co.....	103	International Gem Co.	62	Roy Watch Case Co.....	103
aschkopf, Henry	31	Irons, Joseph	112	Rudolph & Snedeker	103
assett Jewelry Co.	34	Irving Cut Glass Co.	110	Rumpp, C. F., & Sons	112
ates & Bacon	14	Jacot Music Box Co.	116	Saunders, Meurer & Co.....	58
erge, J. & H.	114	Janttschek Co.	38	Schultz & Co., Inc.....	30
illings, Chester, & Son.....	54	Jeanne, F. A.	52	Sessions Clock Co.	102
isbop, R. W.	102	Jorgenson, F. C., & Co.....	116	Shepard Mfg. Co.	39
Jackinton, R., & Co.....	12	Juergensen, Jules	103	Simmons, R. F., Co.....	22
olles, Wm., Co.	112	Kahn, L. & M., & Co.....	46	Smith, Alfred H., & Co.....	50
onnet, L.	31	Keller Jewelry Mfg. Co.....	28	Smith, Frank W., Co.....	16
orrelli & Vitelli	60	Kent & Woodland	28	Smith, Wm., & Co.....	35
owden, J. B., & Co.....	33	Ketcham & McDougall	38	Snow & Westcott Co.	29
radley Polytechnic Institute	102	Keystone Watch Case Co.....	94	Sohn & Hyman	62
riggs, D. F., Co.....	16	Kirby, H. A.	66	Solidarity Watch Case Co.....	21
riggs Plano Co.	116	Kohlbusch, Herman, Sr.	112	Spencer, E. L., Co.....	35
arter, Howe & Co.....	27	Kohn, Alois, & Co.....	31	Star Watch Case Co.....	8
atham National Bank	68	Kremenz & Co.	25	State Bank	68
hicago Art Metal Works.....	32	Krower, Leonard	39	Steiner, Louis	110
hopard Frères	30	Langendorf Watch Co.	100	Stern & Corn	37
incinnati Gold & Silver Refining Co.....	36	Larter & Sons	44	Stern Bros. & Co.....	52, inside back cover
onley & Straight	114	Lederer, S. & B., Co.....	36	Sternau, S., & Co.....	14
ottle, S., Co.	29	Leiman Bros.	108	Stilwell, L. W.	112
rees & Court	38	Lelong, L., & Bro.....	115	St. Louis Watchmaking School.....	103
rohn, M.	36	Lewy & Cohen	33	Street, Geo. O., & Sons.....	62
ross & Beguelin	54, 66	Lisner, D., & Co.....	18	Superior Comb Co.....	88
rossman Co.	52	Lissauer & Co.	56	Sussfeld, Lorsch & Co.....	39, 110
rouch & Fitzgerald	110	Lorsch, Albert, & Co.....	46	Swartzchild & Co.	82
ay, Clark & Co.....	29	Lowe, Edwin, & Co., Inc.....	36	Tavannes Watch Co.	82
eacon, Louis J.	32	Maintien Bros. & Elliot.....	40	Theberath & Co.....	27
ederick's, James H., Sons	114	Market & Fulton National Bank.....	68	Thomas, Seth, Clock Co.....	99
ixon, Wm., Inc.....	114	Marson, A.	115	Title Guarantee & Trust Co.....	68
Moran, Bagnall & Co.....	36	Mercantile National Bank.....	69	Trout, Charles L., & Co.....	30
orflinger, C., & Sons	110	Meyerowitz Bros.	48	Untermeyer-Robbins Co.	70
draper, O. M., Estate	37	Miller, Fuller & Whiting Co.....	37	Urich, S.	100
dubois Watch Case Co.....	96	Mount & Woodhull	56	E. S. Smelting & Refining Works.....	115
ueber-Hampden Watch Mfg. Co.....	10	Myers, J. A.	88	Van Dam, Eduard	48
unn, T. J., Co.	30	Myers, S. F., Co.....	34	Van Dusen & Stokes Co.....	17
urand & Co.	26	New England Watch Co.	101	Wachenheimer Bros.	35
iechberg & Co.....	62	New York Jewelry Purchasing Co.....	37	Wachter Mfg. Co.....	74
Eisenmann Bros.	54	New York Standard Watch Co.....	98	Wadell Show Case Co.....	116
Elgin National Watch Co.	92	New York Tortoise Shell Co.....	62	Wadsworth Watch Case Co.....	9
P. P. H. Chain Catch	32	Nissen, Ludwig, & Co.....	28	Waite-Thresher Co.	40
Fahys, Joseph, & Co.....	3	Noel, Rudolph, & Co.....	50	Wakefield & Seller Co.....	18
Feldenheimer, Louis	62	Oneida Community, Ltd.....	Outside back cover	Waldron & Carroll	32
Foster, Theodore W., & Bro. Co.....	42	Oppenheimer Bros. & Veith.....	48	Waltham Clock Co.	103
Frennd, Henry, & Bro.....	17	Oskamp-Nolting & Co.....	34	Waltham Watch Co.	90
Friedlander, R., L. & M.....	48	Osmers-Dougherty Co.	28	Washburn, C. Irving	34
Farreud & Griser	37	Osmun-Parker Mfg. Co.	26	Wells, Chester H.	34
Gibson Building	88	Ostby & Barton Co.	15	Wendell & Co.	7
Gillette Sales Co.....	41	Owanda Cut Glass Co.	110	Wheeler, Hayden W., & Co.....	52
Goldsmith, C. P., & Co.....	84	Page-Davis Co.	88	Whiting & Davis	15
Goldsmith, Leo.	52	Papazien, A. D.	103	Whiting, F. M., & Co.....	74
Goodfriend Bros.	58	Patek, Philippe & Co.....	100	Whiting Mfg. Co.....	13
Gorham Co.	64	Penfold, Wm. C., Co.....	82	Wightman & Hough Co.....	34
Grand Rapids Show Case Co.....	116	Pitcairn, W. S.	112	Wolcott Mfg. Co.	6
Griffoul, August	115	Pitzele, S.	33	Wolfsheim & Sachs	38
Gugenheim, M.	33	Potter & Buffinton Co.	35	Wollstein, L. & M.	115
Hagerstrom Co.....	31	Pratt, J. W.....	19, 20	Wood, Chas. F., & Co.....	54
Hagstoz, T. B., Ltd.....	114	Prior, Charles M.	30	Wood, J. R., & Sons	4, 5
Hammel, Riglander & Co.....	11	Providence Stock Co.	38	Zarembowitz, A.	108
Harris & Harrington	102	Racine, Jules, & Co.....	102	Zimmern, Henry, & Co.....	115

Special Notices.

Payable invariably in advance.

Rates 75c. per insertion for notices not exceeding 25 words; additional words, 2c. each.

SITUATIONS WANTED, 1c. a word each insertion; minimum charge, 25c.

Heavy type, 5c. a word; minimum charge, \$1.25. Display cards, \$2.00 per inch.

In all cases, if answers are to be forwarded, 10c. extra to cover postage must be enclosed.

All answers to advertisements addressed care The Jewelers' Circular-Weekly, should be sent to the New York Office, unless the Chicago Office is specifically mentioned.

Situations Wanted.

WANTED, position in jewelry store by first class engraver. Address "A. F., 3819," care Jewelers' Circular-Weekly.

FIRST CLASS setter and engraver wants position; best of references. Address "S., 3843," care Jewelers' Circular-Weekly.

A JEWELER and setter wants to get a position, can do engraving. Xaver Langenwalter, third floor, 300 E. 83d St., New York.

POSITION WANTED by engraver; all kinds of lettering and monograms; references given. Urban Dean, Cameron Mills, N. Y.

WANTED, a position by a young lady as an engraver and saleslady; good reference. "R. E. D., 3831," care Jewelers' Circular-Weekly.

POSITION desired by a gilder, capable of making all colors, understands polishing and lapping. Address "N., 3824," care Jewelers' Circular-Weekly.

EXPERIENCED watchmaker and engraver, with tools and best references, wishes to make change. Address Alfred Napoleon, General Delivery, New York.

YOUNG MAN, with over five years' experience in jewelry business, wants position in retail store. Address "A. B. C., 3817," care Jewelers' Circular-Weekly.

YOUNG MAN, 23, wishes position in the silver or jewelry line; seven years' experience as salesman and stock clerk. "L. M., 3866," care Jewelers' Circular-Weekly.

JEWELER and engraver, also watchmaker, wishes to change; south preferred; competent young man; references. Address "V., 3779," care Jewelers' Circular-Weekly.

POSITION WANTED by first class jobbing jeweler, special order work, stone setter and colorer; 20 years' experience. Address M. J. Nolan, 357 E. 134th St., New York.

FIRST CLASS mechanic, new and repair work, also salesman, desires position; can give reference and security. Address "H., 3839," care Jewelers' Circular-Weekly.

STENOGRAPHER, bright, ambitious, beginner, desires position; can help in jewelry department; moderate salary with advancement. Rose Wotieky, 445 E. 87th St., New York.

FIRST CLASS diamond setter desires position with good firm; A1 references; no objection to going out of town. Address "P., 3870," care Jewelers' Circular-Weekly.

FIRST CLASS watchmaker, 15 years' experience, desires position April 1; capable of repairing and adjusting high grade work. Address "R. A. L.," care Carrier 31, Utica, N. Y.

POSITION WANTED by young man to finish trade; can do engraving and watchmaking; have full set of tools and good references. "M., 3836," care Jewelers' Circular-Weekly.

CHASER; first class chaser wants position; can work any metal; 10 years' experience; can also design; silver specialist. "Repousse," 639 W. Lafayette Ave., Baltimore, Md.

DESIGNER on class pins, medals, badges and fraternity pins, desires position with reliable house; can make attractive sketches. "C., 3076," care Jewelers' Circular-Weekly.

YOUNG MAN, of good address, desires position to finish trade under first class workman; four years' store experience; good reference. "F., 3822," care Jewelers' Circular-Weekly.

MANUFACTURER'S LINE wanted for New York jobbing trade, by young man, age 29; will take moderate salary for first year. Address "T. B. V.," 171 Broadway, New York.

YOUNG MAN, thoroughly experienced in the jewelry business, wishes position as salesman; can furnish first class reference. F. Winter, 312 Stockton St., Brooklyn, N. Y.

YOUNG MAN would like good, steady position as engraver; capable of handling fine class of work; good reference; west preferred. Address "A. M.," 6400 Emerald Ave., Chicago, Ill.

YOUNG MAN, 22, neat, with experience in jewelry business, desires position in wholesale or retail store; best reference furnished. "C., 3815," care Jewelers' Circular-Weekly.

WATCHMAKER and engraver, no other class of repairs; 30 years' experience; A1 references, state salary you pay and all particulars. Apartment 1, 1650 N. Clark St., Chicago, Ill.

YOUNG LADY, thoroughly experienced in the jewelry and silver business, and competent bookkeeper, desires position. Address "J. P. S., 3789," care Jewelers' Circular-Weekly.

FIRST CLASS watchmaker, with full set of tools and good references, wishes position with reliable house in New York City or vicinity. "L. L., 3805," care Jewelers' Circular-Weekly.

EXPERIENCED watchmaker and engraver would like permanent position in first class store, desires a change; east preferred. Address "A. R., 3845," care Jewelers' Circular-Weekly.

A FIRST CLASS watchmaker, experienced in adjusting, manufacturing and repairing high grade watches, wants position. Address "L. F. P., 3763," care Jewelers' Circular-Weekly.

FIRST CLASS jewelry repairer, new work, with best reference, desires position in New York City or a position at a Summer resort. Address "B., 3867," care Jewelers' Circular-Weekly.

FIRST CLASS watchmaker, jeweler and optician, with 12 years' experience, wishes position in central north; can furnish best of reference. G. H. Ross, 805 N. Division St., Appleton, Wis.

JEWELER, experienced on fine diamond platinum mountings and gold work, with some knowledge of designing, desires steady position. Address "A., 3884," care Jewelers' Circular-Weekly.

WATCHMAKER and clock repairer, single man, 15 years' experience; no engraver; Ohio or adjoining States preferred; moderate salary. Address "Watchmaker," 818 Main St., Sidney, O.

FIRST CLASS jeweler, age 32, married, wants good, steady position on new and repair work; give best of reference; good habits; is willing to go west. Wm. Vehs, 778 Hunterdon St., Newark, N. J.

ENGRAVER, general letter and monogram work; experienced young man; can act as salesman; good habits; samples and best references. Address "U., 3861," care Jewelers' Circular-Weekly.

WANTED, position by young lady with three years' office experience, writing good hand and able to furnish good references; moderate salary. Address "I., 3828," care Jewelers' Circular-Weekly.

PERMANENT POSITION wanted by a good, all around workman, can do nice engraving and is a good salesman; first class references; reasonable wages. Address P. O. Box 107, Linden Heights, O.

SITUATION WANTED by first class watchmaker, salesman and optician; capable of managing; 21 years' experience, 36 years old, single; A1 reference. Address "R. J., 3722," care Jewelers' Circular-Weekly.

FIRST CLASS engraver, understands watchwork and can wait on trade; eastern middle States, New York City, Brooklyn or near vicinity preferred. Address "B., 3820," care Jewelers' Circular-Weekly.

WATCHMAKER, 20 years' experience on high grade watches, desires position with first class jeweler; able to serve on trade, take in and deliver work. "B. M., 3883," care Jewelers' Circular-Weekly.

WANTED, position by first class engraver, jeweler and salesman, second watchmaker; southern California, southern Arizona or southern New Mexico. Address "Engraver," 124 E. Olive Ave., Redlands, Cal.

WATCHMAKER, of great ability and long experience; no trouble with Swiss, English or complicated watches; best references; want \$25 per week offer. Address "N., 3859," care Jewelers' Circular-Weekly.

ENGRAVER, young man, desires position with first class engraver, or an opportunity to learn watch work; good script letterer; samples on request; A1 reference. "D., 3602," care Jewelers' Circular-Weekly.

ENGRAVER, clock and jewelry repairer, salesman and assistant watchmaker, wishes position; seven years' experience; 20 years old; own tools; best reference. Address "L., 3858," care Jewelers' Circular-Weekly.

YOUNG MAN, 23, thoroughly acquainted with trade from New York to coast, desires to connect with reliable manufacturing concern; highest reference. "Industrious, 3859," care Jewelers' Circular-Weekly.

MANUFACTURING JEWELER, stone setter, engraver, wishes position; four years in last place; best of reference; would take a position to manage place. Address "L., 3876," care Jewelers' Circular-Weekly.

MANUFACTURER'S LINE wanted on commission for jobbers or department store trade for New York City; established trade, can show good improvements. Address Erle R. Sheppard, 53 Maiden Lane, New York.

POSITION WANTED by young man, 35, as superintendent and foreman in silver shop; 20 years' experience, five years superintendent and foreman; A1 references. Address "Z., 3792," care Jewelers' Circular-Weekly.

YOUNG MAN, 21, having six years' experience at manufacturing jewelry, understands retail trade, wishes position in or outside of Chicago; has tools; first class references. "H. M.," care Ben Roth, 204 State St., Chicago, Ill.

SITUATION by jobbing jeweler, can take charge of shop, all around man, can act as second watchmaker, 25 years' experience, best of references, married, or would rent space in shop. Address "M., 3736," care Jewelers' Circular-Weekly.

A FIRST CLASS watchmaker, 25 years' experience on high grade American and Swiss watches, wishes a steady position; can start at once in vicinity of New York City. Address "K., 3541," care Jewelers' Circular-Weekly.

A FIRST CLASS watchmaker, with many years' experience in high grade adjusting and complicated watch work, wishes to make a change in his position; Pacific or western State preferred. "Watchmaker, 3750," care Jewelers' Circular-Weekly.

FIRST CLASS watchmaker, jeweler and plain engraver; competent on high grade work; good salesman; steady, reliable and experienced; able to take entire charge; first class references. Address "G. T., 3864," care Jewelers' Circular-Weekly.

CONSCIENTIOUS young man, 20, desires position with wholesale or retail jewelry firm; six years' experience in retail jewelry store in the capacities of salesman, stock and shipping clerk, best reference furnished. "J., 3872," care Jewelers' Circular-Weekly.

FIRST CLASS watchmaker, 14 years' experience; competent on railroad and finest watches, also engraver, jeweler and salesman, would like permanent position; first class references. Address G. E. Miller, care L. Hubschman, 177 S. Halsted St., Chicago, Ill.

I WISH to make a change, so I am open for a position April or May; fine watchmaker and engraver with 25 years' experience; east or south preferred; will send samples of work and best of references. Address "Engraver, 3833," care Jewelers' Circular-Weekly.

PRACTICAL watchmaker and French clock repairer, 27 years of age, nine years' experience, wishes steady position with first class house only; capable of taking full charge of repair department; A1 reference furnished. Address "Practical, 3741," care Jewelers' Circular-Weekly.

A1 WATCHMAKER, fine engraver and graduate optician, 23 years' experience; several years in present position as first man in large store; do not repair clocks or jewelry; would not go east of Indiana; \$18 to \$20; first class references. Address "S. J., 3802," care Jewelers' Circular-Weekly.

A JEWELRY SALESMAN, having a strong acquaintance among the large department stores and jobbing trade of the middle west, desires to connect with a representative manufacturer, either on salary or commission basis. Address "E. M. L., 3847," care Jewelers' Circular-Weekly.

SITUATIONSWANTED.—Continued

WATCHMAKER, engraver and optician wants position with a first class house; short hours; do no clock or jewelry repairing; has tools and trial case; years' experience; want to take full charge of watch repair bench; good references. Address B. W. Lockner, P. O. Box 212, Hahnibal, Mo.

IRST CLASS watchmaker, experienced on high grade Swiss and American watches, understands railroad work and inspection, capable to take charge over watch repair department; 20 years' experience, can take position at once; best reference and tools. Rudolph Lenzen, 88 River St., Hoboken, N. J.

ALESMAN, of intelligence, good habits and well recommended is open for engagement; sold general line in Ohio and Pennsylvania; well acquainted in large towns and cities; east or west with jobber or retailer; manufacturer's line preferred. Address "Opportunity, 3719," care Jewelers' Circular-Weekly.

PTICIAN, first class refractionist, edge grinder and salesman, competent to take charge of department, who is also all around man in jewelry store, would like good position after April 15, or would like good business proposition; medium size, busy New England city preferred; references. Address "Q., 3840," care Jewelers' Circular Weekly.

ATCHMAKER; are you in need, at once, of an A1, all around man of 40 as watchmaker, jeweler, diamond setter, engraver, optician and salesman; 16 years' experience, 14 years as manager, buyer and all around man in the one store; competent to take charge of store or any department; no bad habits; best of bank references and otherwise; only permanent position considered; state requirements and best salary you can pay in first letter, and whether you will pay transportation. Address P. O. Box 335, Burlington, Ia.

Side Lines Wanted.

WO EXPERIENCED salesmen, with headquarters in San Francisco, want strong lines for the retail jewelers or department stores on the Pacific coast; references. Address 1537 Fulton St., San Francisco, Cal.

OMMISSION LINE wanted; I want one or two representative manufacturers' lines on commission basis for western territory; I have a good following and can produce the orders; I want only best grade of goods. Address "J., 3889," care Jewelers' Circular-Weekly.

Help Wanted.

ATCHMAKER WANTED, with tools; state experience, salary wanted and send references. G. S. Easton, Onsted, Mich.

ERMANENT POSITION to capable watchmaker on railroad watches; references required. Cosley, the jeweler, 1107 16th St., Denver, Colo.

ANTED, jeweler and engraver; send samples of engraving, reference and full particulars, also state salary expected. V. E. Jacobs Co., Jacksonville, Fla.

ATCHMAKER; assistant watchmaker for large store in northern New York; salary between \$14 and \$15. Address "P., 3673," care Jewelers' Circular-Weekly.

IRST CLASS watchmaker and engraver to take charge of watch department; steady position; send references, state age, experience and salary wanted. S. Spitz, Santa Fe, N. M.

NGRAVER and die sinker wanted; must be capable of doing first class work in gold and steel, also familiar with modeling in wax. Address "E., 3849," care Jewelers' Circular-Weekly.

ANTED, watchmaker for ordinary work, and good at French and American clocks; state age, experience, references and wages expected. A. W. Austin, 40 Wall St., Norwalk, Conn.

ANTED, three or four first class diamond polishers. Address, "D., 3690," care Jewelers' Circular-Weekly.

ATCHMAKER and engraver of experience, who may wait on trade; permanent and pleasant position, send specimens of engraving and photo; state salary. L. M. Barnes, North Adams, Mass.

WANTED, first class jeweler to take charge of shop with retail store in Illinois; give references; permanent. Address "K., 3781," care Jewelers' Circular-Weekly, 501 Heyworth Bldg., Chicago, Ill.

WATCHMAKER, or watchmaker and plain engraver for seaside resort, 45 minutes from New York; pleasant, permanent position for right party. Apply "C., 3888," care Jewelers' Circular-Weekly.

WANTED, a first class watchmaker, jeweler, plain engraver, also optician, one who can wait on trade; must have good references; steady position; state salary wanted. D. M. Rinaldo, Hot Springs, Ark.

SALESMAN WANTED; fine, compact side line on commission; well known Chicago house; well advertised goods; an unusual opportunity; reliable and first class. Address "A., 3818," care Jewelers' Circular-Weekly.

WANTED, A1 watchmaker; must be thoroughly competent on high grade Swiss and American watches, and a thorough mechanic, no one else need apply; sample of staff with first application. Julius C. Walk & Son, Inc., 10 E. Washington St., Indianapolis, Ind.

WANTED, July 1, salesman for high grade line of gold jewelry and novelties; Pennsylvania territory; only experienced men with trade need apply; state salary wanted and full particulars; confidential. "Good Chance, 3837," care Jewelers' Circular-Weekly.

WANTED, by first class house in large Texas city, first class jeweler and engraver on new work and repairs; permanent position, good salary; send samples of engraving and copy of references in first letter. Address "L., 3694," care Jewelers' Circular-Weekly.

WANTED, salesman with established trade among high grade jewelers and large department stores in the eastern States to handle line of hand made jewelry and art pieces for manufacturer on commission basis; write for personal interview. Address "B., 3825," care Jewelers' Circular-Weekly.

WANTED, first class watchmaker, jewelry repairer and engraver, also good on clocks; permanent position to efficient man; wages no object; must own tools, except bench and foot wheel; one of the nicest cities in Montana; state salary and all information in first letter with references. "M., 3881," care Jewelers' Circular-Weekly.

WATCHMAKER and jewelry repairer wanted; preferably one understanding French, German and English; congenial position in New York City. Address, "N. F. R., 3709," care Jewelers' Circular-Weekly.

Business Opportunities.

WANTED, partner, young man, watchmaker, with \$2,000 to invest. For particulars address 205 N. Union Ave., Pueblo, Colo.

J. M. ROSSI, 20 Maiden Lane, New York, desiring to retire from active business, will sell his entire stock of high grade jewelry amounting to about \$2,000.

FOR SALE, old established jewelry store, 25 years; with stock and fixtures or without stock; retiring from business; good place for a watchmaker. 393 Myrtle Ave., Brooklyn, N. Y.

BEST LOCATION in Philadelphia, reasonable; good paying retail jewelry store; ill health compels me to retire. For further information address Max Mayer, 942 Market St., Philadelphia, Pa.

\$1,000 WILL BUY an old established jewelry store in South Brooklyn, N. Y.; a splendid opportunity for a good man; reason for selling, other business. Address "V., 3835," care Jewelers' Circular-Weekly.

FOR SALE, on account of sickness, an enameling shop for jewelry, established for 25 years; would also accept a competent man for partner instead; location, Newark, N. J. Address "E., 3757," care Jewelers' Circular-Weekly.

FOR SALE; an opportunity to get an old established jewelry store, on one of the best streets in Washington, D. C., salable and clean stock, with a good repairing trade. For further information address "Opportunity, 3668," care Jewelers' Circular-Weekly.

AN OLD ESTABLISHED first class jewelry store in one of the busiest districts of Boston; owner made a fortune there, but must sell on account of other business on hand; price, \$3,500; stock can be reduced. Address "P., 3827," care Jewelers' Circular-Weekly.

FOR SALE, best jewelry store in good manufacturing town of 5,000 inhabitants; best location; stock and fixtures invoice about \$3,000; good chance for a live man; asthma and poor health only reason for selling; must change climate. Address Chas. P. Eisenmann, Three Rivers, Mich.

HIGHEST cash prices paid for watches, diamonds and jewelry; quick and liberal returns; all business confidential; bank references. E. Noel, 552 E. 46th Place, Chicago, Ill.

A WELL ESTABLISHED house of both manufacturing and importing jewelry specialties in gold only, and is doing a steady business with the best trade in the large cities, would like to negotiate with a small manufacturing concern that make staple gold goods with a view to taking the greater part of the output; all communications confidential. Address "C., 3842," care Jewelers' Circular-Weekly.

FOR SALE, a complete jewelry factory, formerly Eisler & Laubheim's shop, at 87 Maiden Lane; large and light; modern machinery, models, dies, safes and fixtures; includes lease; all at very reasonable price; splendid opportunity. "A. S.," Room 55, 65 Nassau St., New York.

DO YOU NEED MONEY? If so, send your diamonds and watches to me and get quick and liberal returns; highest cash prices paid for entire jewelry stocks; will send our representative if necessary; business confidential; National Bank references. H. Schwartz, 807 Chicago Savings Bank Building, Chicago, Ill.

DO YOU WISH TO RETIRE? Why not turn your entire store or surplus stock into cash? We pay the highest prices, also advance liberal cash amounts on stocks; communicate with us before consulting others; we act quick and strictly confidential. Brooklyn Purchasing Syndicate, 608 Broadway, Brooklyn, N. Y., Telephone, 2328 Williamsburg.

To Let.

FOR RENT, part of fine light diamond office. Room 16, 68 Nassau St., New York.

PART of desirable office occupied by silversmiths, Room 308, 320 Fifth Ave., cor. 32d St., New York.

TO LET, half of light office, including window; suitable for man with desk and work bench; mail privilege \$2 per month. Room 101, 1 Maiden Lane, New York.

TO LET, a desirable office, 170 Broadway, with or without partitions; liberal reduction in rent. Particulars, Room 1003, 527 Fifth Ave., New York.

PART of fine, large office, suitable for silversmiths or jeweler; ample space for show cases; reasonable rent; possession immediately. Room 53, 3 Maiden Lane, New York.

TO LET, third floor of building in Newark, N. J., opposite Market St. station, with steam heat, power and elevator service; size of floor, 115 ft. by 39 ft.; well lighted and specially adapted for manufacturing jewelers. Address Cyrus Currier & Sons, 365 Market St., Newark, N. J.

FINE large space for jewelry counter and watch repairing bench in big, new, up-to-date drug store; no other jeweler in town of 6,000 in Winter, and 50,000 in Summer; space will be rented outright or percentage on sales taken; this is a chance seldom offered. Apply by letter or call W. Chubbuck, Rockaway Beach, N. Y.



HAT PINS

We have A NEW CREATION and A WINNER
(PATENT APPLIED FOR)

Description:

Shapes—Pear and Ball. Finish—Bright, highly polished, English Gold Surface. Engraved in various designs, such as stars, leaves, etc. Set with Brilliant Rhine Stones. The Bright Cutting and Engraving show up in BRIGHT SILVER. The stones are set and beaded in and the entire effect is like Diamond Work in GOLD and PLATINUM. This Pin makes a beautiful, elite, useful piece of jewelry that will sell at sight at a handsome profit to the dealer.

Ask your Jobber for same or Send for Selection We manufacture the largest line of Rhine Stone Mounted Combs in the United States, also Solid Gold and Diamond Mounted Combs.

SUPERIOR COMB CO.

Factory and Office, 43 JOHN ST., NEW YORK.

San Francisco and Coast:

J. H. SPIRO, - Mutual Bank Building, San Francisco, Cal.

Buffalo and Northern States:

W. OTTO LEHSTEN, - 421 Ellicott Square, Buffalo, N. Y.

South:

Mr. MARK WEISS

Middle West:

Mr. SAM. KLEIN

New York City and Large Centers:

Mr. A. HALLEL

Mr. RALPH M. COEN

To Retail from
\$1.00 up

Special Notices.

(Continued from page 87.)

For Sale.

JEWELER'S SAFE for sale; dimensions, 34 x 38 x 40; price, \$50; New York. Address "V. 3879," care Jewelers' Circular-Weekly.

STREET CLOCK for sale; Ansonia street clock, 36 inch dial on heavy ornamental standard, all in good condition, will sell cheap. Address "O. 3848," care Jewelers' Circular-Weekly.

FOR SALE, one 5 foot 6 inch mahogany roll top desk and chair; also one-fourth horse power electric, direct current, huffing and polishing motor lathe, complete with starting box and bench; in perfect running order; would be useful to any jeweler who is without one; bargain. Towie Mfg. Co., 41 Union Sq., New York.

Wanted to Purchase.

WANTED, wall case, 16 to 20 feet; also silent salesman cases for Brooklyn store; must be cheap for cash. Apply "K., 3887," care Jewelers' Circular-Weekly.

WANTED, show cases, watch sign, polishing lathe and safe, suitable for small jewelry store, in good order, cheap for cash. "Jeweler," 1253 Sterling Place, Brooklyn, N. Y.

Miscellaneous.

I WOULD LIKE to know the present whereabouts of one Thomas Gwaltney, a watchmaker. Address P. W. Caine, 567 Pearl St., Beaumont, Tex.

WATCH REPAIRING, pivots, mainsprings, jewels, 50 cents each; staffs, cleaning, cylinders, hairsprings, 75 cents each; gold bought. Frederick Dreher, 78 Nassau St., New York.

ALL MODERN styles of lettering and monograms engraved on a plate by an eminent artist, value \$10, sold for 50 cents. Address Charles Silberman, engraver, 30 E. 14th St., New York

FOREMAN WANTED

for factory, manufacturing sterling silverware. A party is wanted experienced in all details of getting out hollow ware, flat ware, silver jewelry and novelties. A good mechanic with executive ability will be liberally dealt with. Address in confidence, stating full particulars, if employed at present, salary desired and age.

Address "STERLING," 794 Broad St., Newark, N. J.

IF YOU WANT A POSITION
YOU WANT A SALESMAN
YOU WANT A WORKMAN
YOU WANT TO EXCHANGE
YOU WANT A PARTNER
YOU WANT TO SELL OUT
YOU WANT TO SELL TOOLS
YOU WANT TO LET A PLACE
YOU WANT ANYTHING!

USE THE

Want Advertisements

of the

JEWELERS' CIRCULAR - WEEKLY



Light Lofts To Let

IN THE NEW

GIBSON BUILDING

N. W. Cor. John and Gold Streets
NEW YORK

About 4,200 square feet for Light Manufacturing or Show Rooms.

ELECTRIC ELEVATOR AND STEAM HEAT

All lofts wired for power. Apply to your Broker or on Premises.

S. F. MYERS BLDG.

47-49 Maiden Lane, N. Y.

For Rent

A few choice, light and very desirable offices

Moderate Rentals

Details of

J. A. MYERS

On Premises

LEARN JEWELERS ENGRAVING

"The Engraving School that Graduates Experts."
A fascinating, high-salaried and easily learned trade, taught thoroughly and practically by correspondence. Your instructor is the foremost authority and master workman in the world. We will teach the beginner better engraving by correspondence than he can gain in years of rigid apprenticeship. We will improve the skill of any engraver one hundred per cent. and make him master of the trade. The demand for competent engravers far exceeds the supply. Send for handsome, illustrated prospectus.

PAGE-DAVIS COMPANY,
Suite 10, 90 Wabash Avenue, CHICAGO.

Every Repairer "The Jewelry Repairer's Handbook"
Should Have a Copy of
Price 75 Cents

ISSUED BY

THE JEWELERS' CIRCULAR PUBLISHING CO., 11 John St., New York

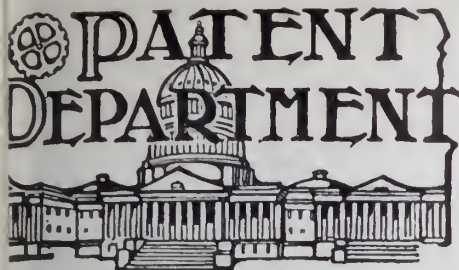

IN WHICH IS CONTAINED A LIST OF THE LATEST PATENTS GRANTED BY THE UNITED STATES AND GREAT BRITAIN, THE UNITED STATES PATENTS THAT HAVE EXPIRED AND THE REGISTERED TRADE-MARKS.]

UNITED STATES PATENTS.

ISSUED MARCH 24, 1908.

882,810. RING. DEWEY F. ADAMS, Providence, R. I. Filed June 28, 1907. Serial No. 881,216.
In a finger ring the combination with a split

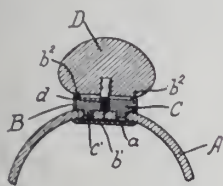

hoop, of a shell inclosing the ends of the hoop, a plate within the shell, an ornament, and means upon the ornament for engaging the plate.

883,121. AUTOMATIC TIME-VALVE. ARCH. A. SHINGLETON, Cincinnati, O. Filed May 27, 1907. Serial No. 375,797.

In an automatic time-valve, the combination of a clock mechanism, a valve, a crank shaft journaled adjacent to said clock mechanism and to

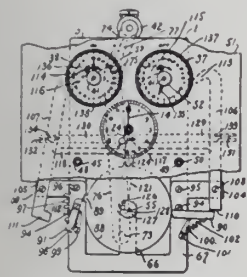

said valve, operative connection between said valve and said crank shaft whereby said valve may be opened and closed by the rotation of said crank shaft, means for rotating said crank shaft, a sheave on said crank-shaft, a lug on said sheave, a stop pivotally mounted adjacent to said sheave and operative connection between said stop and said clock mechanism whereby the operation of said cam is controlled.

DESIGNS.

39,213. HANDLE FOR SPOONS, FORKS AND SIMILAR ARTICLES. THOMAS B. LASHAR, Bridgeport, Conn., assignor to the Interna-



tional Silver Co., Meriden, Conn. Filed Feb. 24, 1908. Serial No. 417,608. Term of patent 7 years.

39,214. PLATE OR SIMILAR ARTICLE. JOHN



WILLIAM POINTON, Burslem, England, assignor to Maddock & Miller, New York.

Filed Feb. 24, 1908. Serial No. 417,609. Term of patent 7 years.

BRITISH PATENTS.

(ABRIDGMENTS OF SPECIFICATIONS, 1908, FROM THE Illustrated Official Journal.)

ISSUE OF MARCH 11, 1908.

25,954. BROOCHES, ETC. W. WINGROVE, 6 Newcastle Place, London, E. C. Nov. 16. Watches, pendants and other ornaments are at-

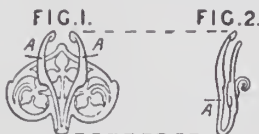

tached to wearing-apparel by means of a brooch, etc., provided with a double spring hook A, over which the bow of the article is passed.

26,086. ELECTRIC CLOCKS. J. STEIGER and J. BESANCON (trading as Steiger & Besancon), 5 Rue de la Paix, La Chaux-de-Fonds, Switzerland. Nov. 17.

The wheel q of the clock work turns the lever l, which carries a contact n, about its pivot m until the engaging piece on the lever escapes from the teeth when it is returned by the spring r,

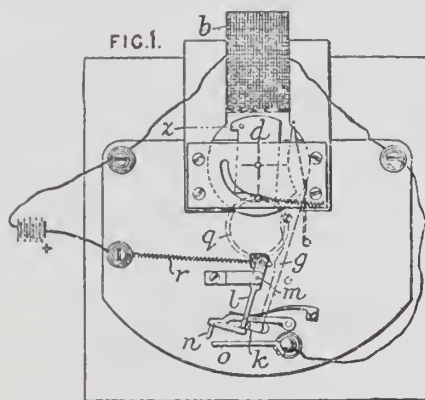

closing the circuit of an electro-magnet b through a fixed contact o. A pin s on the armature d immediately breaks the circuit by rocking a spring-actuated intermediate lever g, which puts the lever l again into engagement with the wheel by means of a pin k, and a pawl on the armature winds up the clock-work.

Complete specifications accepted March 4, 1908. 1907.

- 4,435. UMBRELLA. BERRY.
- 10,375. BRACELET. ANTROBUS.
- 12,011. BRACELET. HELLYAR.
- 18,355. CUTLERY HANDLE. ELKINGTON & Co. & CLARK.
- 22,313. BROOCH. LOEFL.
- 22,343. SPECTACLE CASE. BARRON. 1908.
- 452. HAT-FASTENER. CURDLING & HUGHES. Application filed Feb. 24 to Feb. 29, 1908.
- 4,106. AUTOMATIC EYEGLASS HOLDER. T. M. HAUGHTON, London.
- 4,109. CANDLESTICK. W. T. NEWBOLD, London.
- 4,214. FOUNTAIN-PEN. G. R. HUGHES, Paternoster Row, London.
- 4,367. BRACELET. WILLIAM CLARK, London. Complete specification.
- 4,374. DIAL PLATE. LIPMANN FRERES, London. Complete specification.
- 4,379. WATCH. EMANUEL SIMONS, London.
- 4,406. MEANS FOR INSERTING SLEEVE-LINKS. G. A. HOBBY and ALFRED PAYNE, Southampton.
- 4,420. HAT-PIN. GEORGE PRITCHARD, Regent's Park, London.
- 4,616. TIME-RECORDER. A. R. JENNINGS, London.
- 4,640. BRACELET. L. F. BRENNER, London.
- 4,641. COMB. L. F. BRENNER, London.

UNITED STATES PATENTS THAT HAVE EXPIRED.

[Reported especially for THE JEWELERS' CIRCULAR-WEEKLY by R. W. Bishop, Patent Attorney, Washington, D. C.]

Issued March 24, 1891.

- 448,672. POCKET TOBACCO-CUTTER. H. T. REED, Revere, Mass.
- 448,712. ELECTRIC TIME ALARM. J. J. GALLAGHER, St. Louis, Mo.
- 448,734. DIAL-ENAMELING MACHINE. T. F. SHERIDAN, Springfield, Ill.
- 448,803. BUCKLE. SIMON SCHEUER, New York.
- 448,877. WATCH. ALBERT CHOPARD, Moutier-Grandval, Switzerland, assignor to the Societe Industrielle, same place.
- 448,885. FOUNTAIN-PEN. M. W. MOORE, Springfield, Mass., assignor to J. E. Chase, Holyoke, Mass.
- 448,892. FINGER-RING. CHRISTOPH STAIGER, Brooklyn, N. Y.
- 448,893. CLASP. W. H. THOMPSON, East Stroudsburg, Pa.
- 448,896. JEWEL-SUPPORT FOR BALANCE-STAFFS. JULES VILLON, Lima, Peru.
- 448,930. STOP-WATCH. ROBERT BRAGGE, Aston, England.
- 448,933. COMBINED PEN-HOLDER, PEN-EXTRACTOR AND PAPER-KNIFE. T. B. A. CHAMBERLAIN, Toronto, Canada.
- 448,939. FOUNTAIN-PEN. II. M. CRONKHITE, United States Army.
- 448,998. INDEPENDENT ELECTRIC CLOCK. W. S. SCALES, Everett, Mass., assignor of two-thirds to J. H. Clark, Quincy, Mass., and J. B. Humphrey, Boston, Mass.
- 448,999. SECONDARY ELECTRIC CLOCK. W. S. SCALES, Everett, Mass., assignor of two-thirds to J. H. Clark, Quincy, Mass., and J. B. Humphrey, Boston, Mass.
- 449,016. PENDULUM-ADJUSTMENT. F. M. WAKEMAN, Nantucket, Mass. Design issued March 20, 1894, for 14 years.
- 23,136. PLATE. C. E. HAVILAND, Limoges, France. Designs issued March 26, 1901, for 7 years.
- 34,267. SPOON. TYLER CALHOUN, Ridgetop, Tenn.
- 34,268. CUP. C. J. AHRENFELDT, New York.
- 34,269 and 34,270. PLATES. C. J. AHRENFELDT, New York.

Denver.

P. M. Jones, Saguache, Colo., has been in this city for a few days, buying stock.

Other out-of-town jewelers in this city last week were: Mr. Herman, Brighton; L. E. Guyer, Brush, Colo.

C. Neilsen and Charles Anderson, with Syman Bros., returned last week from a hunting trip into the mountains.

Dan. S. Park, of Dan S. Park & Co., Cheyenne, Wyo., was in this city for a few days last week looking after his business interests here.

The Lewis Jewelers' Supply Co., of this city, W. R. Livingston and R. S. Johnston, Brush, Colo., have filed a petition in the United States Circuit Court asking that L. E. Gier, of Brush, be declared a bankrupt. The claims of the local concern is for promissory notes amounting to \$233 and a merchandise account of \$266.

Owing to the explosion of a quantity of carbon, the store of the West Texas Jewelry Co., Abilene, Tex., and a number of others were badly damaged, March 18.

W. R. Wilson, who conducts a store at Douglas, Ga., and W. A. Walker, Broxton, Ga., have opened a retail jewelry store at the latter place.

Waltham Watches

The history of the WALTHAM WATCH COMPANY is the history of watch manufacturing in America. More than half a century ago this Company introduced a new principle in the construction of watch movements, and has ever since applied the most advanced methods, producing always the best watches in the world. The WALTHAM WATCH COMPANY has built within its own walls the marvelous machinery employed in making the 15,000,000 Waltham watch movements now in use

Waltham Watch Company

WALTHAM, MASS.



THE HOROLOGICAL REVIEW

A CATECHISM OF THE LEVER ESCAPEMENT

Being an Informative and Instructive Series of Questions and Answers
for Watchmakers and Apprentices.
(Written expressly for THE JEWELERS' CIRCULAR-WEEKLY by T. J. WILKINSON.)

(Continued from issue of March 18.)

QUESTION:—Name the angles which originate at the pallet center.
ANSWER:—Lock of tooth on pallet (Fig. 29); lift on impulse face of the pallet (Fig.

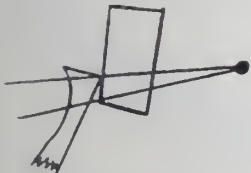

FIG. 29.

30); lift on impulse face of escape wheel tooth (Fig. 31); freedom of the roller jewel as it enters from corner of the lever notch (Fig. 32), lever against bank; freedom of roller jewel from tip of lever horn (Fig. 33); freedom of guard pin or finger from

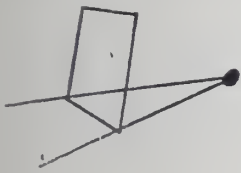

FIG. 30.

edge of roller table (Fig. 34); freedom of roller jewel in notch of the lever.

QUESTION:—Name the angles which originate at the center of the escape wheel.

ANSWER:—The width of the pallet jewel (Fig. 35); the width of the escape wheel tooth (Fig. 36).

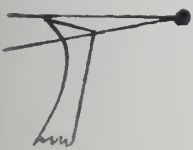

FIG. 31.

QUESTION:—Name the origin of the angle which produces draw on the pallet.

ANSWER:—The angle which produces draw is measured from the lowest locking corner of the pallet jewel (N K, Fig. 37).

QUESTION:—From what point is the angle

which forms the locking face of an escape wheel tooth measured?

ANSWER:—From the corner (S, Fig. 38).

QUESTION:—What is the slant K to O termed on a pallet stone? (See Fig. 37.)

ANSWER:—It is called the impulse or lifting face of the pallet jewel.

QUESTION:—What is the term applied to that part of a tooth, R to S, Fig. 38?

ANSWER:—It is known as the impulse or lifting face of the tooth.

QUESTION:—Point out in Fig. 37 and Fig.

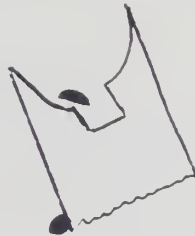

FIG. 32.

38 the locking faces of the pallet and tooth respectively.

ANSWER:—The locking face of the pallet is that part from B to K, Fig. 37, and the locking face of the tooth is that part from S to T, Fig. 38.

QUESTION:—How much of the locking



FIG. 33.

face of a tooth should come in contact with the locking face of a pallet jewel?

ANSWER:—Only the corner S, Fig. 38, of the tooth, should rest on a pallet jewel's locking face.

QUESTION:—How should a roller jewel be selected to fit the lever notch (A) so it fits without side shake, (B) so it has a little side shake, (C) or so it has considerable side shake?

ANSWER:—A roller jewel should be

selected to fit the notch of the lever so it has a little side shake.

QUESTION:—If the roller jewel fits the lever notch without having any side shake, how does it affect the motion?

ANSWER:—It causes a sluggish motion of the balance.

QUESTION:—Suppose that a roller jewel which is a correct fit for the lever notch is

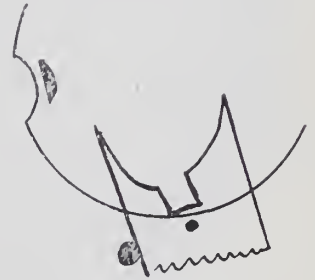

FIG. 34.

set sidewise in the manner indicated in Fig. 39. State its effect.

ANSWER:—Owing to the slant of the roller jewel, it will bind in the lever notch in exactly the same manner that a larger jewel set upright will do.



FIG. 35.

QUESTION:—Suppose you have a watch in which the roller jewel is decidedly too small for the lever notch. State what irregular motion would be observed.

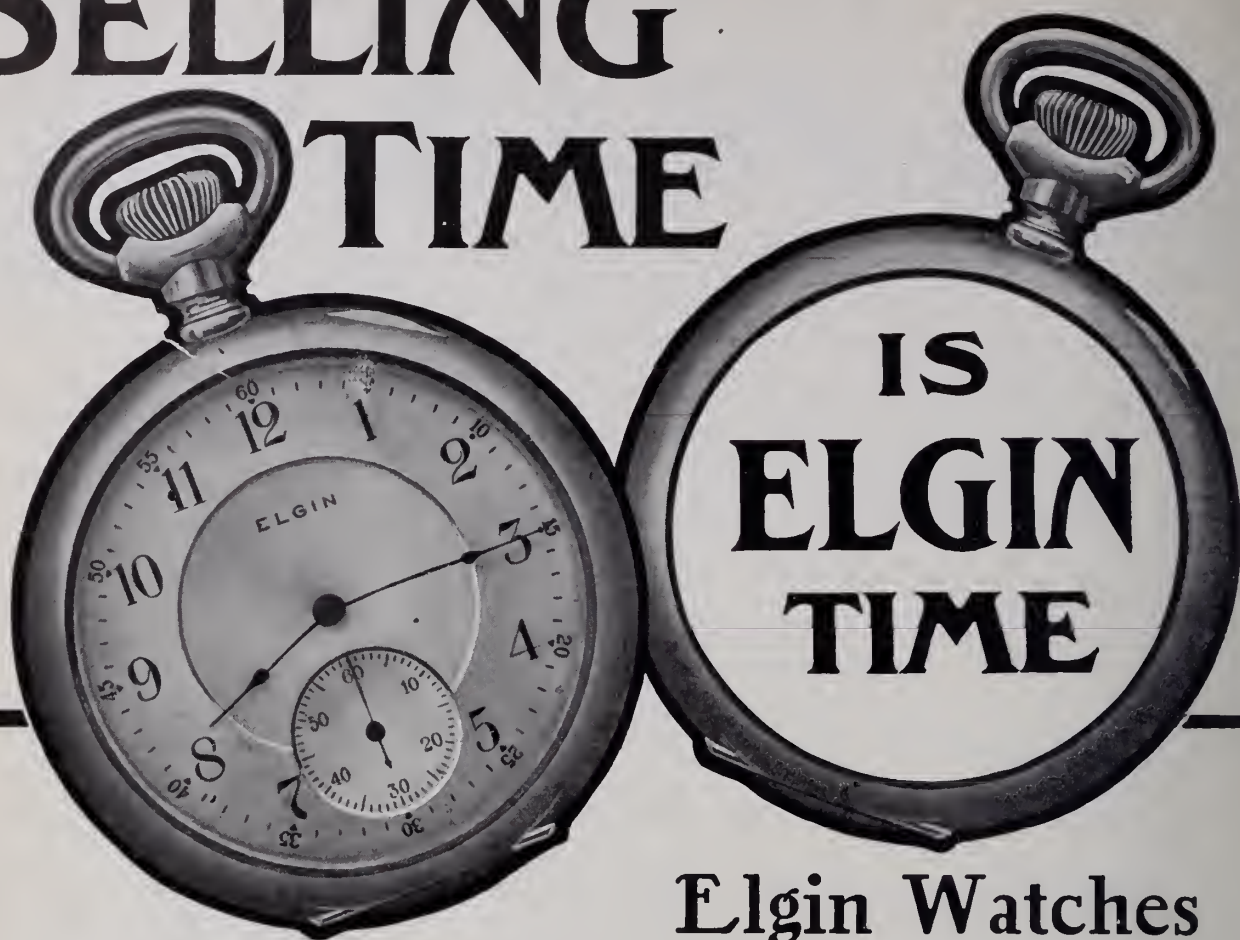

FIG. 36.

ANSWER:—When the roller jewel entered and struck the side of the notch the unlocking blow, a jump of the lever would be observed.

QUESTION:—How would you examine a single-roller escapement in order to deter-

SELLING TIME



Elgin Watches Know No Season

They are quick sellers all the year round. The demand is steady and constantly increasing. Dealers who carry a full stock of ELGINS are reaping the benefit of our extensive newspaper and magazine advertising.

Is your line complete?

The G. M. WHEELER Grade ELGIN, "*The Watch That's Made for the Majority,*" meets the great demand for a reliable watch at a popular price, and can now be had in various sizes and stylish thin models for men's and boys' use.

See jobbers' list for prices or write the Company.

The Elgin Art Booklet, "*Timemakers and Timekeepers,*" is yours for the asking. Send for it.

ELGIN NATIONAL WATCH COMPANY,

Factories: Elgin, Ill, U. S. A.

General Offices: 131 Wabash Ave., Chicago.

New York Office: 11 John St.

San Francisco Office: 704 Market St.

mine if the roller jewel could come in contact with the lever horns.

ANSWER:—This can be done by pressing the guard pin against the edge of the roller table and rotating the roller jewel past each curve of the horn.

QUESTION:—Should the roller jewel touch the horns?

ANSWER:—No.

QUESTION:—In what form of escapement when being tested is it correct for the roller jewel to touch a part of each lever horn?



FIG. 37.

ANSWER:—In double-roller escapements only.

QUESTION:—When does this take place?

ANSWER:—When the guard finger is within the crescent, and in order to test this phase of the safety action we lift the lever off its banking; pressing it forward, we find that the roller jewel will, under such conditions, meet the curve of the horn.

QUESTION:—When testing a single-roller escapement, what part of the fork will touch the roller jewel, and under what conditions?

ANSWER:—While the roller jewel in



FIG. 38.

single-roller escapements will not touch the curve of the horn so long as the guard pin remains without the crescent, yet we find that the moment the guard pin enters the crescent we can push the lever sufficiently forward to bring the roller jewel in contact with the corner of the notch. (See Fig. 40.)

QUESTION:—Suppose that when we have the guard pin pressed against the edge of the roller table we find that the roller jewel sticks in the manner indicated in Fig. 41. Would you consider this effect as correct?

ANSWER:—No. A correction is called for



FIG. 39.

which will prevent this decided catch of the parts.

QUESTION:—What correction is required?

ANSWER:—It will depend on the cause of the error. A full series of tests should be made to locate the cause. (These escapement tests we shall later explain.)

QUESTION:—During the action of a sound escapement when do we find the guard pin closest to the edge of the roller table?

ANSWER:—As soon as it makes its exit out of the crescent.

QUESTION:—When is the guard pin at its greatest distance from the edge of the roller table?

ANSWER:—When draw or second lock is complete—i.e., when the lever is at rest against its bank.

QUESTION:—Should the guard pin, when a watch is running, be found in more or less contact with the roller table?

ANSWER:—No. The guard pin should not touch the roller table.

QUESTION:—When would you expect the guard pin to come in contact with the edge of the roller table?

ANSWER:—When, from some violent shock, the lever jumps off its banking.



FIG. 40.

QUESTION:—What helps the lever to return to its banking?

ANSWER:—The guard pin meeting the roller table, and the draft angle on the pallet jewel's locking face.

QUESTION:—Would a roller table with any roughness or burr on its edge be liable to cause trouble?

ANSWER:—Yes. It will cause stoppage; hence all rough-edged roller table should be polished.

QUESTION:—State the office of the guard pin in single-roller escapements?

ANSWER:—(1) It prevents overbanking; (2) in the event of the watch being subject to hard usage it prevents the roller jewel from butting on the end of the lever horn, or the face of the lever horn touching



FIG. 41.

the roller jewel; (3) it prevents tripping.

QUESTION:—What is meant by the term "overbanking"?

ANSWER:—When a watch is overbanked the roller jewel is found resting on the outside edge of the fork, due to some error whereby the lever leaves one banking and passes over to the opposite banking in an irregular manner; hence the roller jewel on its return excursion strikes on the outside of the horn.

QUESTION:—What are the causes of overbanking?

ANSWER:—Overbanking might be due to a guard pin being bent away from the edge of the roller table or to a loose guard pin, a roller table being out of true, pivots of the balance or pallet staff or lever being too small for their respective holes or jewels.

QUESTION:—What are the requirements for the second office of the guard pin?

ANSWER:—The guard pin to be so adjusted that under no circumstances can the roller jewel ever strike any part of the lever horn.

QUESTION:—The third function of the guard pin is to prevent "tripping." Define this term.

ANSWER:—By tripping is meant the act of a tooth of the escape wheel leaving the locking face of the pallet jewel and entering onto the pallet's impulse face in an irregular manner. For instance, if we brought the guard pin against the edge of the roller table and found with the guard pin in this position that the tooth of the escape wheel had entered onto the impulse face of the pallet we would have a tripping error to contend with. Such an error must always be corrected.

QUESTION:—Give some of the causes of a tripping error.

ANSWER:—(1) The guard pin being bent away from the edge of the roller table; (2) the pivots of any of the parts being too small for the holes they work in; (3) extremely light lockings of the escape wheel teeth on the pallet jewels, especially when other parts are slightly ill fitting, will produce a trip.

(To be continued.)

No Reimbursement for Milwaukee's Ruined Street Clocks, Says City Attorney.

THE city attorney of Milwaukee, Wis., has rendered an opinion that the jewelers who suffered damages to their street clocks recently, can make no claim against the city. If they do receive any reimbursement, it must come from Mayor Sherburn M. Becker and the firemen who participated in the raid.

"I would be glad to see the jewelers get the money they are entitled to," said Mr. Kelly, the city attorney, "but they cannot legally collect it from the city, because those street clocks had no right under the law to be upon the sidewalks."

The Milwaukee Jewelers' Club has asked Alderman Yockey to present a resolution asking for the establishment of street clocks. It is said that if this measure is passed the jewelers will allow the city to use their clocks without compensation and without asking damages from the city for the breakage in the recent raid.

No disposition has as yet been made of the injunctive suit instituted by David Goldman to restrain the city from interfering with the re-erection of his clock. The questions raised by the demurrer of the city have been submitted to Judge Tarrant by way of briefs. The injunction had been modified to the extent that Mr. Goldman was ordered to remove his clock from the sidewalk and to refrain from re-erecting it between adjudication of the suit.

A. G. Kountz, Pittsburg, Pa., is the inventor of an improvement for winding indicators for timekeepers. The invention has for its object the provision of a novel means, to be actuated by a clock, of determining when the mainspring of the clock has become exhausted or the clock has run down.

Keystone Solid Gold Watch Cases



The Smallest Watch Case Made

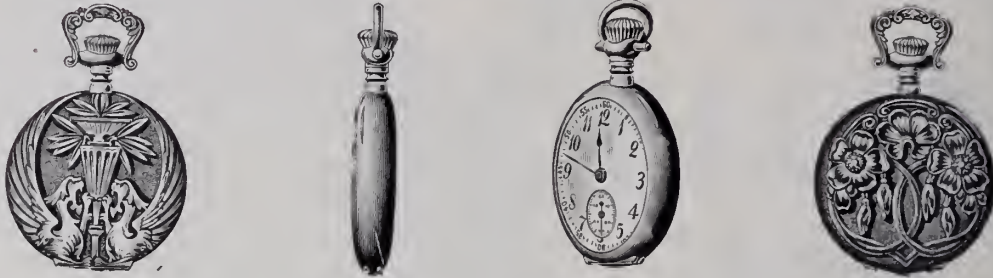

Fitting Lady Elgin Movement
Fitting 10 Ligne Waltham Movement

- ☐ Hunting and Open-Face, Baseine, Plain Polish, Satin Finish and Roman with French Bows.
- ☐ Open-Face Art Nouveau decorations, with and without diamonds. Faney Art Nouveau Bows.
- ☐ Open-Face in **EXCLUSIVE SPECIAL DESIGNS**, a large variety of patterns with enameled and relief work, with and without diamonds and other precious stones.

These **SPECIAL NOVELTIES** are **NOT DUPLICATED**.

- ☐ Hunting and Open-Face Cases made only in good, substantial weights.
- ☐ Open-Face Cases made only with inside caps, jointed backs and bezels.
- ☐ Open-Face Cases all have swivel pendants.
- ☐ All these cases are Made, Engraved, and Decorated by Special Gold Case Artisans.
- ☐ These are all Cased by the **MOVEMENT MAKERS**—

THE ELGIN NATIONAL WATCH COMPANY AND
WALTHAM WATCH COMPANY,

with extreme care in order to assure perfect adjustment, and sold to you by your jobber only as complete watches.

KEYSTONE 14 K. SOLID GOLD CASES ASSAY

585-THOUSANDTHS FINE

14 K. GOLD ASSAYS 583 $\frac{1}{2}$ -THOUSANDTHS FINE

Trade-Mark



in back.

Note this guarantee



in cap.

Look for



this tag.

THE KEYSTONE WATCH CASE CO.

NEW YORK

CHICAGO

PHILADELPHIA

CINCINNATI

SAN FRANCISCO

Completion of America's Largest Tower Clock

The Illuminated Hands Will Serve as a Beacon for Ships in the Harbor

THE largest tower clock ever constructed in America, has just been completed and tested by the Seth Thomas Clock Co., at its factories in Thomaston, Conn. This huge timepiece was built for Colgate & Co., Jersey City, N. J. The clock will be placed on the roof of their factory building, which is located near the Pennsylvania Railroad terminal and the position of the dial will allow the time to be seen from all boats passing on the Hudson River and from office buildings in the downtown section of New York City.

The dial of this gigantic clock will be 40 feet six inches in diameter, and will be made of yellow pine boards six inches wide,

progress of the hands will not affect the time of the movement. Even though it were possible to turn the hands backward it would not cause the pendulum to stop.

The movement is most substantially made with bronze wheels, machine-cut gears and hardened steel pinions. It is equipped with

wheel measures 18½ inches in diameter, and 800 pounds of cast iron will be used to operate the time side of the clock.

The pendulum rod is eight feet long, beating one and one-half seconds, and is made of zinc and steel in such proportions as to allow it to adjust itself to the most acute changes of temperature. In order to obtain this very delicate compensation it was necessary to test the rod in a room of the Seth Thomas factory laboratories, where it first could be heated by coils of steam pipes and then chilled to a low temperature.

The rod weighs 76 pounds and has a cast-



HOW THE HUGE CLOCK WAS TESTED AT THE THOMASTON FACTORY.

spaced three inches apart. The minute hand measures 20 feet from the end of the hub to the tip and weighs, with the counter balance, 640 pounds. The hour hand is 15 feet in length and weighs 500 pounds without the balance. The numerals on the dial are five feet high and 30 inches wide. The blade of the hour hand measures three feet 9 inches in width, while that of the minute hand is two feet 11 inches. The point of the minute hand travels every minute 23 inches, while in a week it covers three and two-thirds miles. The hour hand travels three feet four and three-quarter inches every hour, or 570 feet in one week.

All the wheels of the clock movement are held rigidly in position by a cast-iron bed plate measuring four feet in length. About one-third of this space is occupied by the time train, which releases, every 30 seconds, the remontoire train and allows the hands to move forward one-half minute. The method of releasing the remontoire train is most ingenious, and the mechanism is arranged so that any interference with the

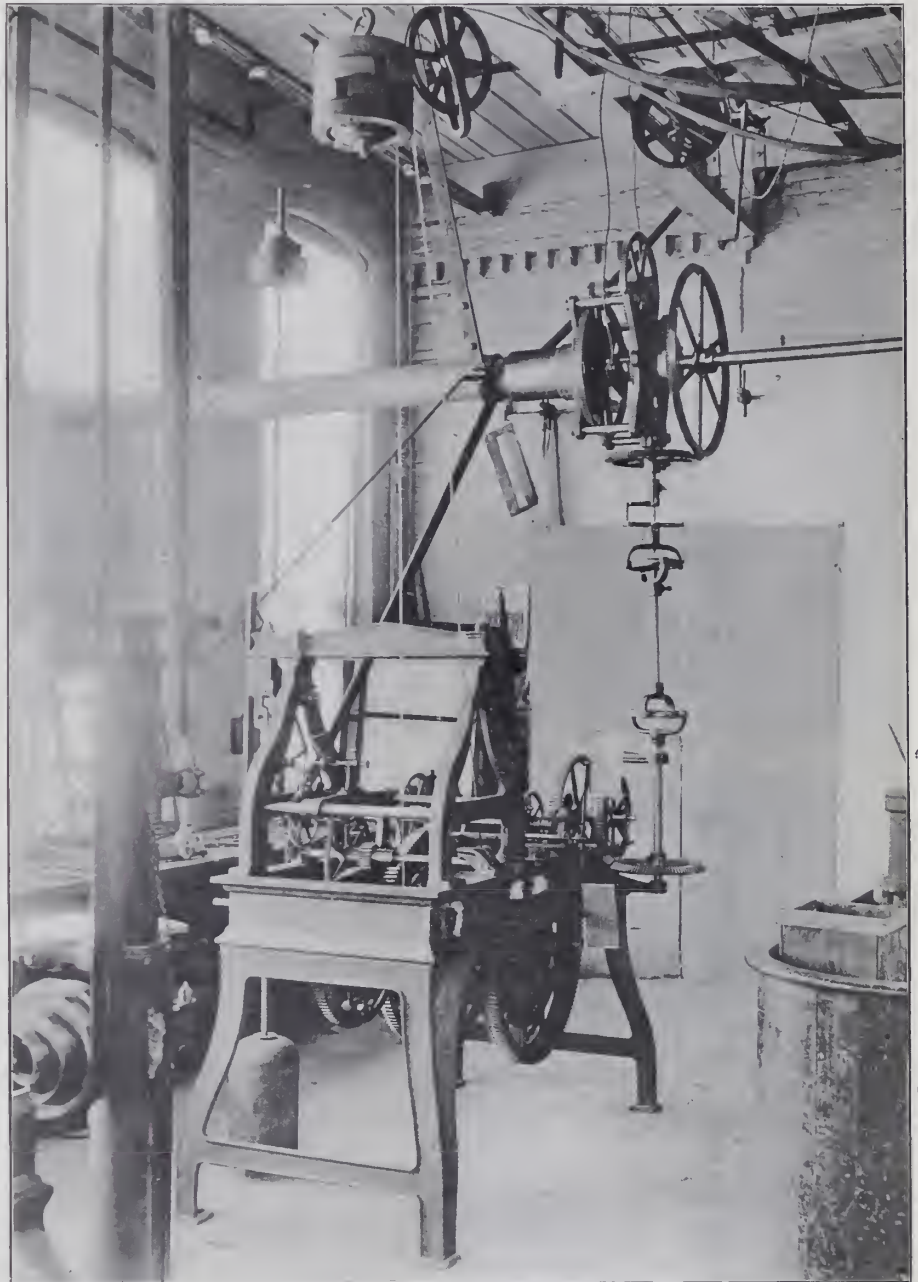

THE INGENUOUSLY CONSTRUCTED MECHANISM OF THE BIG CLOCK.

Sir Edmund Beckett's double three-legged gravity escapement, which was invented chiefly for use on the famous Westminster clock, in London. The gravity arms are suspended from a point very near the suspension spring, and each arm is fitted with a bronze roller beat pin. The main time

iron bob weighing 330 pounds. This bob is cylindrical in form and has a dome-shaped top to prevent particles of dirt from resting there and accelerating the rating of the movement.

The remontoire train, which is connected with the hands, has a main wheel 30 2/5



SIDE VIEW OF WATCH.

DUBOIS Safety Chatelaine Brooch Watch

Patents Pending in U. S. and
Foreign Countries

Made for O size, Jewel
size and smaller watches
in different designs and
styles

Licensed under Wachter Patent
Ball-Bearing Bow



RAISED VIEW.

MERITS

Holds the watch firmly and securely, thus preventing the movement from being jarred, as there is no swinging or bobbing up and down while the wearer is walking or running. Protects both the case and garment from wear.

**Cannot Be Lost
Will Not Pull or Wear Off**

UTILITY

It can be raised so as to read the time, and reversed to have either the dial or back facing front, without removing brooch pin or watch from the garment. Can be worn on the shoulder, belt, chain or fob.



FRONT OF WATCH.

ARTISTIC AND PRACTICAL

The only brooch and watch combined. Affords absolute security, as it has a safety catch. Nothing to wear out, as it works on friction bearings. Eliminates the possibility of loss of the watch owing to either bow, hook, swivel or link wearing out, breaking or coming apart, as in the old style chatelaine. Does not interfere with either winding or setting of movement.

Dubois Watch Case Co.

21 and 23 Maiden Lane
NEW YORK CITY



BACK OF WATCH.

ches in diameter, has 150 teeth with faces one and a half inches inside and weighs 115 pounds. The drum of this train is 17 inches in diameter and carries on it steel wire rope three-eighths of an inch thick, which winds at the rate of 44 feet in 24 hours, or 108 feet in one week. To wind this side of the clock to run a week takes about three hours.

The dial works weigh in all 830 pounds, and are equipped with roller bearings throughout. The minute hand shaft is a steel tube two and seven-eighths inches in diameter, and the hour hand sleeve is three and one-half inches in diameter.

The hands of this clock are exceptionally staunch, being composed of brass truss work covered with sheet copper.

At night the hours will be designated by a row of incandescent bulbs extending through the center of each hour mark. The current used to illuminate the minute hand is carried in wires running through the minute hand shaft, carbon brushes behind the dialworks being employed to transmit the current from the revolving shaft to the generator.

In order to supply the current for the hour hand contact rings are employed on the face of the dial and on the inside of the hub of the hand; here again carbon brushes are used to make the contact as the hand revolves.

A Handless Watchmaker.

WATCHMAKERS with two hands are plentiful enough, but a watchmaker capable of earning his livelihood without any hands at all is indeed an anomaly. Such, however, is J. P. Saunders, of Louisville, Ky., two of whose photographs are

Bureau of Standards, Washington, D. C., Makes Some Interesting Experiments in Rating Watches.

WASHINGTON, D. C., March 25.—R. Y. Ferner, of the Bureau of Standards, has entered into arrangements with several jewelers of this city, including A. O. Hutterly, Galt & Bro., Harris & Shafer Co., R. Harris & Co., to loan to the bureau such watches as they can spare in order that the bureau may carry out certain investigations on the rates of the ordinary stock watches under varying conditions. Other jewelers and watchmakers are welcome to enter into the same arrangements with the bureau, and the watches will receive the best of care while in its charge. No attempt will be made to adjust or in any way change them, the only purpose of the investigation being to determine the uniformity of rates. It is preferred that watches shall be submitted in the same condition in which they are received from the factory, without any



THE GIANT HANDS, WHEN ILLUMINATED.

The illustrations shown herewith were taken at the factory while the clock was being tested. The hands were placed in position at the back of a two-story building. The height of these hands, as compared with that of a man may easily be realized.

The method of illuminating the hands is most unique. The hands will be outlined by a row of lights. Forty-two incandescent lamps will illuminate the hour hand and 25 lamps will outline the minute hand. The hour marks in the day time will be heavy black coffin-shaped strokes 30 inches across at the widest point and tapering to a point at the inner end. The background of the dial will be white and the distance from center to center of the numerals will be 10 feet.



TWO PHOTOGRAPHS OF J. P. SAUNDERS, THE HANDLESS WATCHMAKER OF LOUISVILLE, KY.

shown herewith. He uses only the regulation tools employed in the intricate work, and with only arm stubs where others have 10 fingers, he daily does the most tedious and delicate work in his shop.

Mr. Saunders not only dissects watches and then puts the puzzling pieces back in their proper places, but has learned the manufacturing as well. He can make a minute hand with as much precision and speed as any watchmaker and other intricate parts which are so small as to require constant use of a magnifying glass during manufacture.

Several efforts have been made to induce Mr. Saunders to exhibit his genius in public for pay, but he has refused to leave the shop where he not only makes his own living, but that for his mother as well.

Besides his mechanical ability, Mr. Saunders is a cartoonist. He draws as rapidly as he works with watches.

He even shaves himself, ties his own ties and is as rapid in his dressing as a man with two hands. Mr. Saunders has lived in Louisville since his birth, 34 years ago.

C. G. Swanson, Luverne, Minn., is closing out his stock at auction.

further adjustments than reducing their rate to a few seconds a day.

It is altogether probable that the bureau will want to keep watches thus submitted under investigation for three or four months unless the person loaning them would desire to have them returned before the expiration of such a length of time. At the end of the examination the persons lending any particular watches will be furnished by the bureau with a statement of the observed rates of the different watches, and it is thought probable that the results of the whole study will probably be incorporated in a paper to be published later by the bureau.

Any jewelers interested who will communicate with Mr. Ferner will be furnished with full information as to the types and sizes of watches desired, and any further data that may be of interest.

It is estimated that up to the middle of the last century some 450,000,000 ounces of silver had been taken from the mines of Peru. During that time that country was one of the world's greatest sources of mineral wealth. The chief developments of Peru are of the copper deposits, with silver as a by-product.—*Metal Industry.*

Excelsior Watches

There is a place in every jeweler's stock for the new line of EXCELSIOR watches.

They mean new customers in the store—additional sales—more profits. They do not interfere with the sale of higher-price goods. They simply mean selling a man a real time-piece in place of a cheap toy that there is neither profit nor satisfaction in handling.

The EXCELSIOR watch is distinctly a "trading up" proposition.

Retail selling prices—

	<u>Silverode</u>	<u>10-yr Rolled-Gold Plate</u>	<u>20-yr. Gold Filled</u>
Hunting	\$4.75	\$7.00	\$11.00
Open-Face	4.50	6.00	9.00

Made in 6, 12, 16 and 18-size—Open-Face and Hunting—10 and 20-year Gold Filled cases, or Silverode case. A complete watch, timed in its case and retailed at a fixed price—the price tag affixed to each watch at the factory.

Three-quarter plate, Damaskeened, finished throughout, 7 jewels, quick train, with bearings in metal settings, cut expansion balance, breguet hairspring, white enamel dial. Stem wind and pendant set—except the 18-size Hunting which is lever set.

Inquire of your jobber and write to the factory for literature.

New York Standard Watch Company

Jersey City, N. J.

SETH THOMAS CLOCK COMPANY

Established 1813

MANUFACTURERS OF SUPERIOR TIMEPIECES OF ALL SIZES, STYLES AND PRICES, FROM AN O SIZE LADY'S WATCH TO 40-FT. DIAL TOWER CLOCK—largest in the world (See page 95 of this issue). The greatest variety of timepieces made by any company.

OUR PRODUCT CONSISTS OF

Cabinet Clocks in Mahogany, Flemish and Golden Oak. ¶ Colonial and Arts and Crafts designs. ¶ Hall or Grandfather Clocks, chiming on Cup Bells and Cathedral Gongs. ¶ Regulators and Precision Clocks of great variety and prices. ¶ Marble Dial Hanging Clocks of several patterns and sizes, also fitted with Bronze numerals. ¶ Gallery, Lobby and Double-Dial Clocks for large offices. ¶ Perpetual Calendar Clocks, for mantel and hanging, in various designs and finishes. ¶ All styles of small Office Clocks, 8, 15 and 30-day. ¶ A complete line of jeweled Chronometer Levers in brass and wood cases, also Low Priced Lever Clocks. ¶ "Eight Bells" or Boat Clocks in three designs. ¶ Our popular "Adamantine" line of Wood Mantel Clocks is made in White, Black, Golden Bronze, Mottled Green and Mahogany finishes, of many shapes and prices. ¶ Also Alarm Clocks in many styles and finishes.

EMPIRES OR GLASS REGULATORS

Our line contains every style necessary to suit all tastes. Made in Polished and Satin or Rich Gold, also Bronze, Verde Antique, Cut Glass and Onyx, some with convex fronts, fitted with 8 and 15-day movements. We make a large line of Bronze Art Nouveau Cases with Figures, Vases and Candelabra Side Ornaments to match; also many patterns of 1-Day Metal Novelties.

WATCHES

0, 6 and 18 sizes, including high grade Railroad movements.

TOWER CLOCKS

Street or Post Clocks and Tower Clocks are made in all sizes to fill every possible want.

Catalogues and printed matter may be obtained from your jobbers or from us direct.

51 Maiden Lane
NEW YORK

SETH THOMAS CLOCK COMPANY

70 Wabash Ave.
CHICAGO

Repeated Triumph of the Patek, Philippe & Co. Watches

RECORD of 1907-1908

Kew Observatory Trial of Watches and Chronometers

The First, Second, Sixth, Seventh, Eighth and Ninth
BEST RECORDS

Geneva Astronomical Observatory Timing Contest

53 out of 101 Prizes, namely:

The only First Prize for Best Average Running among Makers

4 First Prizes out of 5

Including all the highest and the nearest to perfection ever obtained by a portable timepiece

10 Second Prizes out of 18

9 Third " " 17

12 Fourth " " 26

7 Honorable Mentions " 18

10 Single Prizes " 17

19 Manufacturers Participated

Awarded Hors Concours (Beyond Competition): Milan, 1906; St. Louis, 1904; Paris, 1900; Paris, 1889; Antwerp, 1885; Zurich, 1883.
Gold Medal: Nuremburg, 1905; London, 1885; Calcutta, 1883; Croningen, 1880; Paris, 1878; Vienna, 1873; Paris, 1867; Paris, 1855;
London, 1851; Paris, 1844. Diploma of Honor: Nice, 1883.

68 Nassau Street, NEW YORK

GENEVA, SWITZERLAND



The above TRADE MARK is well known to you, because it is on every watch and watch movement made by the LANGENDORF WATCH CO.

The more of our large line you carry in stock, the more profitable and satisfactory are

YOUR SALES

Perfect Interchangeability of parts renders repairing easy.

Do not accept substitutes, but insist upon getting the genuine L. W. Co. make. It's far the cheapest after all, as the quality is such you may

DEPEND UPON

If your jobber cannot supply you with

THE RIGHT KIND of GOODS

write to the Sole Agents for the United States,

AMERICAN-SWISS WATCH CO.

1 Maiden Lane, New York
CUSHMAN BUILDING

Practical Course in Adjusting

Published Price, \$2.50

Special Reduced Price, \$1.50, Postpaid

All Jobbers, or

Jewelers' Circular Publishing Co.

WANTED WATCHMAKER everywhere to know about

URICH Perfect Fitting CASE SCREW WASHER

Will hold movements securely in their case, even when shoulder is worn away. Fits perfectly under head of screw, and is almost invisible. Prices:

Single Dozen, - - - - - 15c
4 Doz. Package, assorted, - - - 50c
Gross, - - - - - \$1.50 Pat. app. for

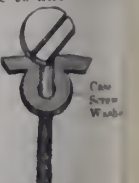

For sale at all Jobbing and Material Houses.
S. URICH, P. O. Box 1942, New York CI

In Every

New England

WATCH

before it leaves the factory is placed a copy of this Guarantee:

OUR GUARANTEE

All New England Watches are warranted free from defects in material and manufacture, and to be correct timekeepers. We agree to make good—free of charge—at our factory in Waterbury, Conn., or at our houses in Chicago and San Francisco, any defects developing within one year from date of purchase, provided such defects do not arise from misuse or neglect.

All New England cases are warranted to be exactly as represented, and all our "filled" cases are warranted to wear the number of years stamped on same.

The New England Watch Co.

Factory and Main Office
Waterbury, Conn.

BRANCHES

Chicago, 131 Wabash Ave.
San Francisco, 717 Market St.

This Guarantee serves as a protection to both the purchaser and the dealer, for it is a direct guarantee from the manufacturer to the wearer.

New England Watches also insure a good profit to the dealer on every one sold. Send for Price-List.

THE NEW ENGLAND WATCH CO.

Waterbury, Conn.

Chicago

San Francisco

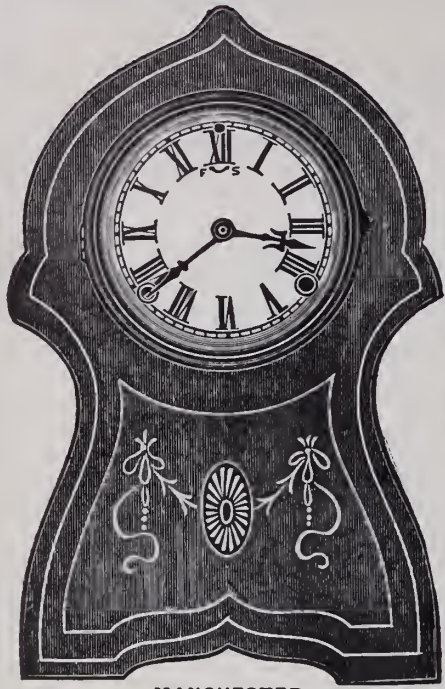

MANCHESTER
Height 13¾ in. Width 8¾ in.

SESSIONS CLOCKS

Superior Finish
Popular Prices

We have added a number of fine marqueterie cabinet clocks to our line which will interest you.

The Sessions Clock Company

FORESTVILLE, CONN., U. S. A.

New York Salesroom, 37 Maiden Lane

HALL CLOCKS



Elliott's
Celebrated
Tubular
Chimes

**HARRIS &
HARRINGTON,**
12 BARCLAY ST.,
NEW YORK

Sole Agents to the Trade
for
J. J. ELLIOTT & CO.
LONDON.

The Lady Racine

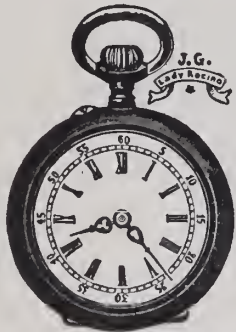

Positively the BEST
chatelaine watch in
the market.

Machine Made

10, 11, 12 and 13 Line; Cylinders
and Levers; cased in Nickel, Gun
Metal, Silver and Gold.

Material on Hand.

Write for prices.

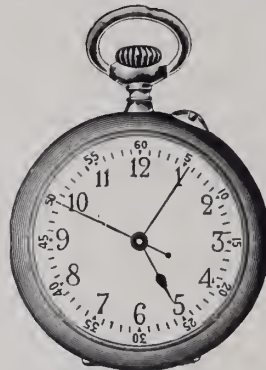

Lady Racine
Nurse Watch.

JULES RACINE & CO.,
103 STATE ST., SOLE AGENTS 37 MAIDEN LANE
CHICAGO. NEW YORK.

For Sale by all Jobbers



THE **R. & L.** OIL

The R. & L. Oil is made especially for those expert watch and clock makers who must have the best and most reliable oil on the market. It does not gum or change, and possesses all the

requisites needed for the most delicate mechanisms. Send 25c. to your jobber, asking for R. & L. Oil.

Wholesale Selling Agents

M. SICKLES & SONS . . . Philadelphia
SWARTZCHILD & CO. . . . Chicago
NORDMAN BROTHERS CO., . . San Francisco
D. C. PERCIVAL & CO. . . . Boston
CHAS. MAY & SON Boston
DANIEL PRATT'S SON
53 Franklin Street, Boston
SUSSFELD, LORSCH & CO., . . New York City
H. S. MEISKEY CO. . . . Lancaster, Pa.

RANLETT & LOWELL CO.

SOLE MANUFACTURERS
Jewelers' Building BOSTON, MASS.

A.W.C.CO

A Trade Builder

An artistically decorated and inexpensive watch case that you can unconditionally recommend; of indisputable beauty and faultless construction. Singularly free from the technical defects common to most moderate-priced gold cases. Built to sell and last, two virtues that will attract and hold trade.

Sold by us directly to you



14K.
C-1460

American Watch Case Co.

9-11-13 Maiden Lane

New York

HOROLOGICAL DEPARTMENT

BRADLEY POLYTECHNIC INSTITUTE
Formerly Parsons Horological Institute
PEORIA, ILLINOIS
LARGEST AND BEST WATCH SCHOOL IN AMERICA
We teach Watch Work, Jewellery, Engraving,
Clock Work, Optics. Tuition reasonable. Board
and rooms near school at moderate rate
Send for Catalog of Information

PATENTS

obtained on inventions and designs. Trade marks, prints and labels registered.

R. W. BISHOP,
ATTORNEY-AT-LAW,

908 C Street N.W., Washington, D.C.

THE Ægis Case

(PATENTED)



THE ÆGIS is a new creation in gold case making. The center and bezel are in one. Instead of having the ordinary Cap, this case is provided with a rigid metal movement Cup, held friction tight in position. This Cup gives protection to the movement such as cannot be secured with the conventional jointed cap, while dust is thoroughly excluded from the front by means of the one-piece center and bezel.

MADE ONLY BY

ROY WATCH CASE CO.

21-23 MAIDEN LANE
NEW YORK

San Francisco Office, 704 Market Street

Learn Watchmaking

Refined, profitable labor. Competent men always in demand. We teach it thoroughly in as many months as it formerly took years. Does away with tedious apprenticeship. Money earned while studying. Positions secured. Easy terms. Send for catalogue. Address

St. Louis Watchmaking School, St. Louis, Mo.

WATCH REPAIRING FOR THE TRADE

Careful, Reliable, Prompt Work. Trade References. Price List on Request.

A. D. PAZIENT

71-73 Nassau St., Cockroft Bldg. NEW YORK

Ball Watches

THE RAILROAD STANDARD

The Watch Inspector's Friend

WRITE TO-DAY FOR OUR DEALER'S PROPOSITION

Minneapolis, March 12, 1908.

Gentlemen:

Your 18 size "Official" No. 548110 arrived just in time to aid me with my watch inspection work, as my electric clock was out of commission for 23 days, during which time your watch varied only 4 seconds. Very respectfully,

L. L. WILLIAMSON

Railway Watch Inspector
1717 E. Franklin Ave.

The Webb C. Ball Watch Co.

Ball Building
Cleveland

Railway Exchange
Chicago

Pacific Type Fast Express Engine for
New York - Boston, Service.

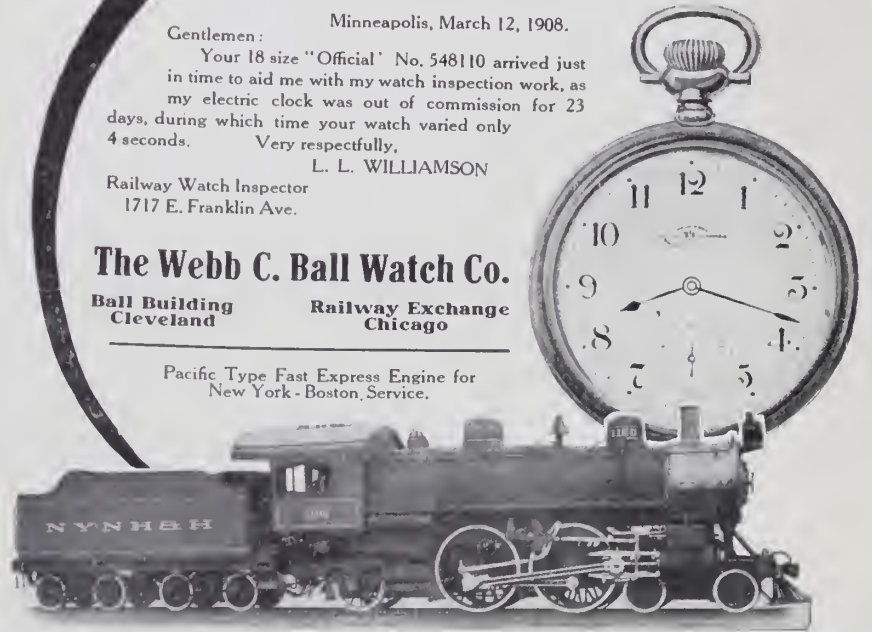

THE progressive jeweler today knows that when a customer comes into his store he must be impressed with the idea that he is doing a high-class business.

In order to do this he must have the goods. No article you can buy will give your store more tone than a fine Hall Clock. It will also give you a fine profit. Purchase a "Waltham" and you will soon find a customer for it.

Send for catalogue, descriptive of many styles and kinds.

WALTHAM CLOCK COMPANY

Office and Salesrooms, Waltham, Mass.

JULES JÜRGENSEN

Watches and Chronometers

PARIS—"THE GRAND PRIX"—1900

SOLE

RUDOLPH & SNEDEKER
65 Nassau St., New York

AGENTS



STORE KEEPING DEPARTMENT

That this department shall prove mutually beneficial to our readers, it is desirable that the members of the trade generally communicate with THE JEWELERS' CIRCULAR-WEEKLY regarding any advantageous device or plan which they are utilizing in connection with their business.

Mechanical Window Displays

Constructed With a View to Enhancing the Attractiveness of the Jeweler's Show Window

By Otto Jonas

A Window With a Bird as Its Central Attraction.

EITHER a stuffed bird or one made of cardboard may be used, and if the accompanying directions are followed an original idea and complete plan for an un-

with blocks of wood nailed to base of window (see Fig. 1). Then a stout packing box (not too large) is nailed to the floor of the window, first boring a hole in one end large enough to permit the insertion of a round stick, e. g., a broomstick, or some

of the box with a similar hole bored through, so as to allow free play for the lower end of the round stick to revolve. The combination will give you a revolving spindle to which an imitation or stuffed bird may be nailed. The stuffed one may be set on a small top nailed to the upper end (Figs. 3 and 4).

If an imitation bird is to be made of cardboard. The front and rear views should be duplicates of each other. The cardboard must be cut out in the desired shape and colored to suit. If a stuffed bird can be borrowed or rented for a small sum the effect will be much more realistic. In the latter case, the bird must be bound very firmly to the small platform nailed at the top of the revolving spiral. In any event the inner workings must be concealed by covering with a board platform or a piece of cloth.

The bird is a very attractive centerpiece for a window, especially if the surroundings are brilliant and effective. Windows have even been worked up in which the sides and background have been made to represent a tree, which the owl or eagle supposed to inhabit.

Since the people who look at the revolving bird naturally follow it with their eyes the goods arranged around it should be ticketed that both prices and wording may be taken in at a glance.

Even if a sign painter had to be employed in order to paint up the bird, the window should cost very little to arrange and if the articles are "home-made," which has and can be done, the cost of the entire display is very nominal. Supposing the bird selected to be an owl, the following sign might be used:

- Get wise like me—
Invest in a ——— alarm clock.
- Is everyone wise to the fact
that these goods are guaranteed
- These stick-pins are "birds."
- Chatelaines are flying into favor.
- Fly in and give our silver-polish a trial
- This silver-polish makes tarnish fly.

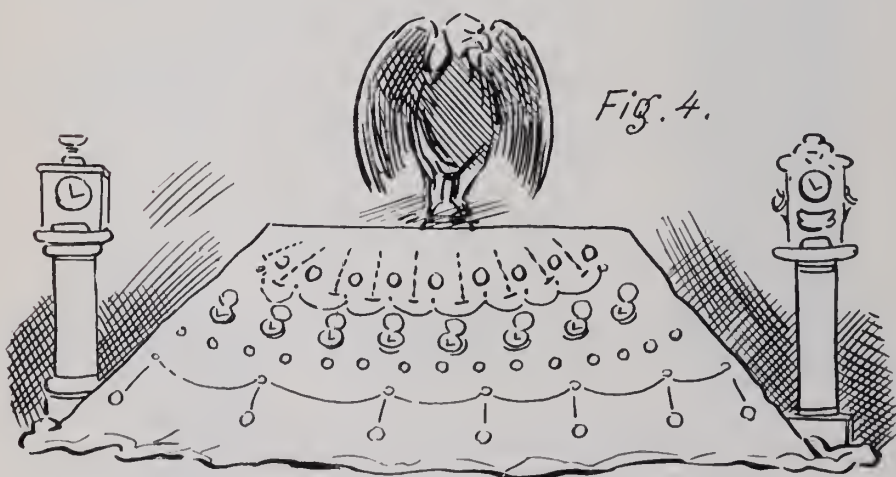
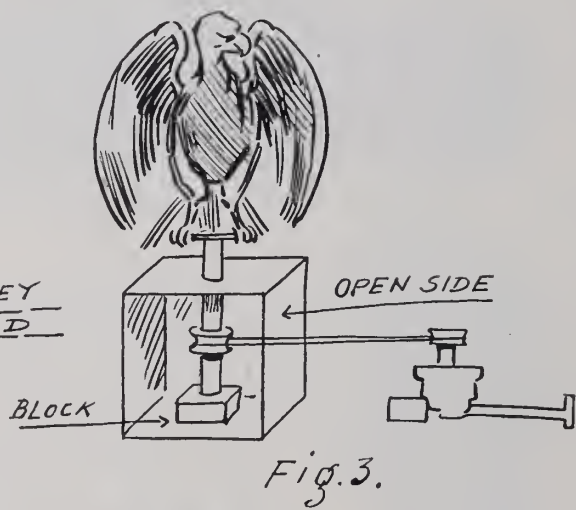
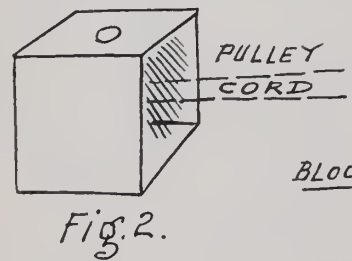
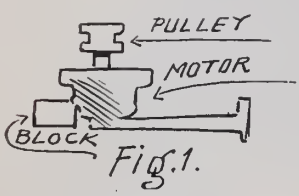

DIAGRAM ILLUSTRATING MODE OF MAKING A REVOLVING WINDOW DISPLAY.

usual moving object window display can be worked out.

Replace your fan blades with a pulley and lay fan on its back holding it in its position

other light stick. Remove the top of the box so as to permit play for the pulley strap.

A block should be nailed on the bottom

Storekeeping Department.

An Easter Window Display.

(For other Easter suggestions see the Anniversary Number of THE JEWELERS' CIRCULAR—WEEKLY, published Feb. 5 last.)

AN original Easter window is shown herewith. Flowers play an important part in the display. A conspicuous feature is a white crêpe paper or silk covered cross with a border of green as a central decoration for the display of fine gold and jeweled crosses, chains and rosaries.

From the ceiling, suspended by ribbons or bands of crêpe paper, are clusters of artificial or real flowers, preferably pink. An edging of the same colored flowers should be placed against the back of the window at the bottom, and also in a large loop in the foreground, curling around the star formed by such ornaments as chains and jewels at the sides.

The candelabras with light green or pink shades make a beautiful appearance, if lighted at night.

Lilies in jardinières at either side and cut glass, watches and chains, or locket, rosaries and jewelry in boxes as shown, complete the window.

A Representative Retail Jewelry Store of Waverly, N. Y.

THE store of Simon Zausmer, Waverly, N. Y., is illustrated below. The sales-room measures 24 by 80 feet. The walls of the establishment are entirely bordered by attractive wall cases, displaying a well-selected stock. There are in all about 110



INTERIOR VIEW OF THE STORE OF S. ZAUSMER, WAVERLY, N. Y.

feet of gracefully designed show cases. The private office is located in the rear of the store. This is built of golden oak, which is the material used in the other fixtures. A predominance of French plate glass adds to the rich effect of this part of

the establishment. The private entrance and accounting department, with gold lettering, and the public entrance complete the background of the store. A well-equipped phonograph department adjoins the office.

tric lamps of 32 candle-power, each, under glass reflectors, and a central cluster of five lamps, having each 32 candle-power. French plate mirrors are arranged in the background and on the sides, thus adding to the brilliance and beauty of the display.

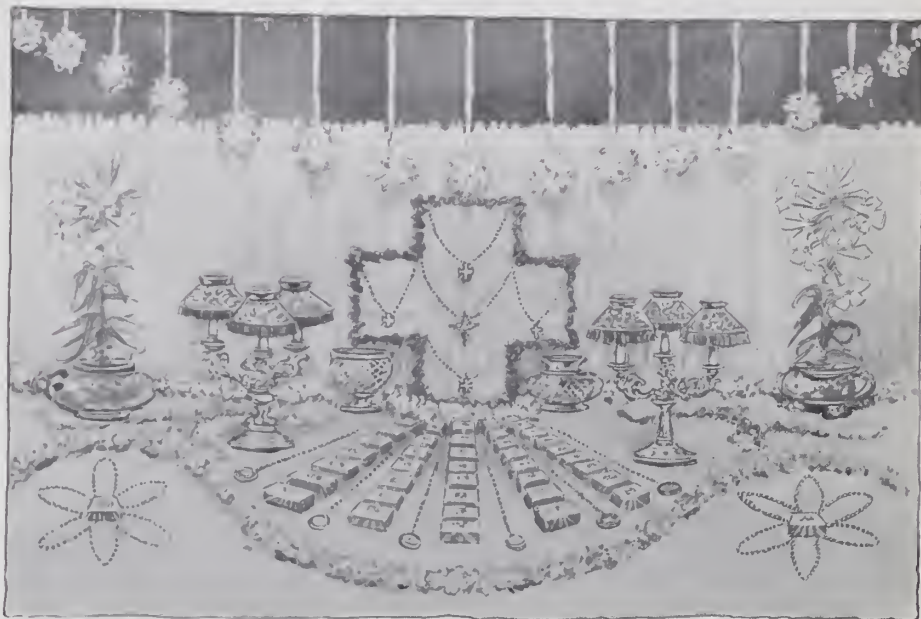

AN ORIGINAL DESIGN FOR AN EASTER WINDOW DISPLAY.
(Drawn expressly for THE JEWELERS' CIRCULAR—WEEKLY.)

The repairing department occupies an annex to the store proper, 18 by 20 feet. This is equipped with all the modern machinery and implements necessary for expedient and skilful work. The store is

In front of the store, just at the curb, Mr. Zausmer has erected an illuminated square sign, 18 inches by nine feet, with raised perforated letters, spelling out the words "Zausmer, Jeweler." This sign is surmounted by an imitation of a diamond ring made of durable metal and covered with gold leaf, the stone being illuminated and thus rendered visible at a considerable distance. This sign, which is the unique conception of Mr. Zausmer himself, has created considerable comment.

Mr. Zausmer not only uses newspaper space very abundantly, but also reinforces his newspaper advertising by taking space in street cars, on bulletin boards and adopting various other schemes of outdoor publicity. In his own words he says: "I really believe that my success is due to advertising the stock which I have to sell. I never advertise anything which I do not have in stock."

A Modern Croeses.

IT is recorded of a young fop who visited one of the Rothschilds that he was so proud of his malachite sleeve buttons that he insisted upon exhibiting them to his host. The latter looked at them, and said: "Yes, it is a pretty stone. I have a mantelpiece made of it in the next room."

Successful Merchandizing.

SELLEMQUICK SENIOR—George my boy, now that you are going into business for yourself, let me give you a good rule to follow.

Sellemquick Junior—Well, father?

Sellemquick Senior—It's this: If your customers don't see what they want, make them want what they see.



RETAIL JEWELERS ADVERTISING

The use of this department is open to every retail jeweler. Forward for criticism your newspaper ads., booklets, catalogues, novelties, circulars, etc. Ask advice and offer suggestions. Replies in these columns are unbiased. Make letters as full and particular as you desire. Every letter and ad. sent will receive full attention, though the publication of the matter may sometimes be delayed several weeks.

APRIL, the month of sunshine and show-ers, has at last arrived after a dreary old Winter, and jewelers have already begun to do praiseworthy Easter advertising. Easter, as everyone knows, falls this year on the 19th of the present month, and from

articles. These should be mailed only to a well-selected list. For an exhaustive discussion on Easter advertising and examples of appropriate Easter booklets and folders the reader is referred to the retail advertising department of the Anniversary Num-

The advertiser is over 70 years of age and is still actively engaged in a successful business. It is rather difficult to account for his discontinuing to advertise during such a long interval, but at any rate he is now celebrating his 53 years in business by an announcement of generous proportions, the original having been 10 3/4 inches long by nine inches wide. This celebration, as the advertisement announces, was marked by a special sale. The advertiser most advisedly and judiciously states that there is to be no reduction in watch repairing, as he is "not giving his time away," only a reduction on his large stock.

A mistake commonly made by many advertisers is their belief that advertising is unnecessary in a city or in a town in which the advertiser's name (but not the stock, remember) is very well known. Such merchants forget that the stock and not merely their names must be thoroughly

THERE ARE RUMORS
That Silver is Going to ADVANCE IN PRICE

We don't believe our Money-Saving Sale of Sterling Silver Table Ware

Coming at 25 per cent. discount on Knives, Forks, Spoons, etc. will be an excellent way to get your Silverware. NOW IS THE TIME TO ORDER BY YOUR SILVERWARE. PRICES ARE SURE TO GO UP

We Are Offering Bargains in many other lines, such as Glass, Brass Goods, Leather, Silver Hardware, etc. etc.

W. C. BRYANT, Jeweler. 16 Main St.
Jewelry Store for 25 Years.

HART

Repairing a Specialty

MY CELEBRATION

FIFTY-THREE YEARS

IN THE

JEWELRY BUSINESS

ON HOWARD STREET

FIFTY-THREE YEARS

Watch Ailment

BRING us an old watch that is giving you trouble. We will repair it for you. We have a special way of repairing watches that is sure to give you a watch that will run for years. We have a special way of repairing watches that is sure to give you a watch that will run for years.

Cochenthaler

BIGELOW, KENNARD & Company, Boston.

Specialty of repairing watches. We have a special way of repairing watches that is sure to give you a watch that will run for years.

YOU SHOULDN'T MISS THIS SALE

A Genuine Jewelry Sale!

Jewelry—Diamonds—Watches—Clocks—Silverware—Cut Glass—Etc.

DISCOUNT 10 to 50 PER CENT.

Watches. 10 to 25 per cent. off

CLOCKS. 20 to 33 1/3 per cent. off

DIAMONDS. 10 to 25 per cent. off

SILVERWARE. 25 to 33 per cent. off

JEWELRY. 20 to 50 per cent. off

MISCELLANEOUS. Great Reductions

It Is Not Old Truck—No Old Truck Here!
It's the Chance for All to Profit

GRAB SALE! FRIDAY, 10 A. M. It's something Different

M. W. BASSETT, 1007 MAIN STREET

DIAMONDS, WATCHES, JEWELRY, CLOCKS AND SILVERWARE

O. H. REMINGTON

53 YEARS AT
33 SO. HOWARD ST.

The First Week of Our Anniversary Sale

For the Second Week

Remember

J. J. Freeman & Co.

507 SUMMIT STREET

HANCHER

Reliable Repairing

When we repair a watch or other article of jewelry you can rely on the long time life.

JEWELER REPAIRER

Always the best at HANCHER'S
1221 MARKET ST.

The Jewelry Sale Worth While Attending!

Sanitation is your most sure way of purchasing Jewelry, Watches, Diamonds, Cut Glass, Clocks, Silverware and hundreds of other miscellaneous articles at this Second Annual Two Weeks Last Sale. The stock supplies with increases, the styles and designs of the different articles reflect the newest in their respective lines. All original price tickets remain—the discounts which range from 10 to 50 per cent. you yourself figure out the price which you are to pay. It's the really and truly great Jewelry Sale. The sale that all who attend may pride by.

Watches. 10 to 25 per cent. off

CLOCKS. 20 to 33 1/3 per cent. off

JEWELRY. 20 to 50 per cent. off

SILVERWARE. 25 to 33 per cent. off

MISCELLANEOUS. Great Reductions

The Event Where You Profit! Rare Opportunities.

M. W. BASSETT, 1007 Main St.,

HERE QUALITY NEVER VARIES

Watch Repairing

Jewelry Repairing

Diamonds Reset

MERMOD JACCARD & KURT

DISCOUNT SALE AND OTHER ADVERTISEMENTS USED LAST MONTH BY RETAIL JEWELERS.

now on a vigorous advertising campaign should be conducted by all retail jewelers who wish to reap the benefit of the public's recently acquired penchant for gift giving on that occasion.

Besides the regular newspaper advertising, jewelers may profitably use attractively printed folders illustrating timely Easter

ber of THE CIRCULAR-WEEKLY, which was issued on Feb. 5.

The advertisements illustrated this week were used during the month of March. One of the most interesting in the group is that of O. H. Remington, Akron, O. As Mr. Remington states in his announcement, this is his first advertisement in 18 years.

familiar to every prospective purchaser. The stock is what chiefly interests buyers, and continuous, live and timely advertising is absolutely essential in order to make it sell satisfactorily and advantageously. Were a storekeeper never to obtain any new stock or any new line kindred to the jewelry trade he would, of course, in a

Retail Advertising Department.

Small town hardly find it profitable to advertise the same thing every day or every week, but, being a progressive, enterprising dealer, he is ever wide-awake and alert to secure novelties and such new goods as will appeal forcibly and convincingly to the buying power in his locality, and these new goods must be advertised regularly, as fresh store news.

W. C. Bryant, Bangor, Me., in an advertisement reduced from $3\frac{1}{4}$ inches, triple column, announces a 25 per cent. discount sale of sterling silver table ware. This advertisement is not at all attractive typographically. The text is fairly well written.

Frank C. Hart, a jeweler of Tacoma, Wash., takes advantage of his name to use the symbol which it suggests as a top piece and border in an advertisement of four lines, single column.

M. Cochenthaler, Norfolk, Va., used the accompanying advertisement in a space of $\frac{1}{4}$ inches, single column. The text reads as follows: "Watch Ailment.—Bring us in that troublesome watch of yours—that is provokingly behind time or wrong some way. It may be only the most trivial of matters that causes it to be so erratic, or there may be something seriously wrong with it. In either case the defect will be correctly diagnosed and treated, if brought to us."

The typographical make-up of the advertisement used by Bigelow, Kennard & Co., Boston, Mass., is certainly unique and sufficiently different to make it conspicuous among other announcements. The concern is advertising its facilities for making over modern pieces of jewelry from obsolete markets. The quaint style of make-up adopted is in keeping with what is advertised.

J. J. Freeman & Co., Toledo, O., advertised an anniversary sale in a well-balanced advertisement which occupied a space of $\frac{1}{4}$ inches, triple column.

Diamond and pearl jewelry is featured by I. W. Curtis, Knoxville, Tenn. The amount of space used for this ad. was $\frac{1}{4}$ inches, single column.

"Cause and Effect" was the catch phrase used in an odd, but nevertheless effective, advertisement by D. Buchanan & Son, Norfolk, Va. The publication of the names of two popular salesmen is a clever conception on the part of the advertisers, and will reflect favorably upon the concern.

J. C. Peers & Son, Rockford, Ill., advise owners of old silverware to purchase a new line, but do not make strong enough the reason why this new line may be purchased to the best advantage at their particular advertisement. The advertisement occupied $4\frac{1}{4}$ inches, single column.

Another discount sale is advertised especially well by M. W. Bassett, Hartford, Conn., in the two advertisements illustrated herewith. The announcement bearing the caption "A Genuine Jewelry Sale" has been reduced from $8\frac{1}{2}$ by nine inches. The second announcement, headed "The Jewelry Sale Worth While Attending," was used in a space of five inches by $15\frac{1}{2}$ inches. The type used in both of these announcements is well chosen. The announcements

themselves are very well balanced. There is a touch of originality in the brief but tersely written introduction in the oblong advertisement.

The Mermod, Jaccard & King Jewelry Co., St. Louis, Mo., in a space of $6\frac{1}{4}$ inches, double column, calls attention to its watch-repairing department, which has been made a feature of that concern's large establishment for some time past.

Arguments Used by Jewelry Advertisers.

APPROPRIATE Gifts for Spring and Summer—Unusually attractive goods suitable for Spring and Summer gifts are coming in daily. We have just gotten in some striking pieces in cut glass, to which we particularly invite your attention. Among other patterns of new cut glass we are showing a new Butterfly and Daisy design, which, besides being handsomely cut, is further ornamented with Intaglio engraving on opaque glass. These new goods are comparatively inexpensive, yet make imposing gifts. Our line of Spring novelties is the largest and most varied in the south. We have a very large line of new and stylish belt buckles, back combs, cameo and coral jewelry, both in solid gold, gold filled and sterling silver. To any one who has inspected our display of sterling silver, it is unnecessary to call attention to the quality and number of different patterns and styles we carry. We are justly proud of our sterling silver, for it is unquestionably the most complete and satisfactory line ever shown in the south. We give especial attention to the wedding present business—no matter how small or how large the order. If your gift is in a Brodnax package it will be doubly appreciated, for our name is a guarantee of the high quality of the present selected. If out of the city, write for our 148-page general jewelry catalogue No. 17. Geo. T. Brodnax, Inc., Memphis, Tenn.

Is Your Silverware Badly Worn? Then replace it with new, for shabby looking silverware detracts greatly from the attractiveness of your table. Teaspoons, dessert spoons, table-spoons in the Rosemary pattern, the prettiest of all plated patterns. J. C. Peers & Son, Rockford, Ill.

Ups and Downs—Whether times are good or bad, during the ups and downs of prosperity or depression the diamond, above all other assets one may have, remains at par. It grows in value every year. Cupid's demands must be met at any cost, and there is nothing the prospective groom could invest in that would please his fiancée more than saving up before marriage and investing in a diamond. It's the "Rock of Gibraltar" behind which you are always safe from need or want. Critzer Bros., San Antonio, Tex.

The Unique, Artistic and Unusual in jewelry is always found in our store, and probably more so this Spring. Among the new and popular novelties you will find the Egyptian Scarab, set in many beautiful designs, the Coral, the new and popular Jade, Amethyst, Topaz, Peridot and other semi-precious jewels so popular this season, set in brooches, lavallieres, scarf pins, rings and many other ways to produce many pleasing effects. Visitors always welcome. Sartor & Roempke, San Antonio, Tex.

Beautiful new cuttings and rich effects in cut glass now on display. Don't miss seeing the new cuttings and effects in fine cut glass ware we are now displaying. No matter whether you are thinking of buying now or not—come in and let us have the pleasure of showing you this beautiful ware. Prices range from \$1.50 upward. Edwards & Le Bron, Chattanooga, Tenn.

New Designs Table Silver—It will certainly be to your advantage to see our sterling silverware stock if you have need of any sort of table ware. You may choose from the handsomest patterns and best qualities that are made, and all are priced as reasonably as those we mention. Choice of three patterns, almost plain, gray finish, or fancy handles, all good weight and engraving included: Six teaspoons, \$4, \$5, \$6; six tablespoons, \$11, \$12; six table forks, \$11, \$12; six dessert forks or spoons, \$8; six medium knives, \$9, \$10. C. L. Ruth & Son, Montgomery, Ala.

You are welcome to come and look over our stock of superb jewelry. If you are in pursuit of wedding or personal gifts, here is the best place to make your selection. Our prices are reasonable. Our values are the best. Our novelties are new. You will be pleased with our diamond and pearl rings and brooches, while our large display of silverware and cut glass makes selection easy. Call and see the good things offered. "The Wedding Gift Store." LeBron Jewelry Co., Montgomery, Ala.

Seasonable jewelry, brooches, bracelets, barrettes, veil pins, neck chains and pendants, lockets, hat pins, belt pins, stick pins, handy pins, lorgnette chains, etc., in solid gold, card cases, pocketbooks, belt buckles, belt pins, picture frames and all the different novelties in sterling silver at the right quality and at the right prices. A. L. Desbouillons, Savannah, Ga.

Jewelry of good taste is just as important as clothes. We buy only the kind we think will please you—the jewelry of good taste. The new goods for the coming season are on display and we would like for you to see our offerings while our stock is complete. Barrettes, veil pins, combs, belt buckles, waist sets, etc., and the prices are right. Cameo stick pins, neck chains and brooches are just what you want for this season. Special—Our \$5 watch is the best on the market for the money. W. G. Myerley, Rich Hill, Mo.

Diamonds—The demand is greater than the supply, and the prices are constantly advancing. An investment—You will find the purchase of a perfect diamond the best investment you can make. Our stock includes pure crystal white, blue white, coffee and canary colored gems. All perfect stones. Our diamond jewelry showing is one of matchless beauty. From single settings to groupings worth thousands of dollars, the range of opportunity for choosing is extremely broad. Special jewel designs made by expert art jewelers. Tourists are specially invited to pay a visit to our store. They will find it one of the most intensely interesting places in California. Brock & Feagans, Los Angeles, Cal.

Arthur Thomas, formerly of Ellingwood, Kans., is now located in Tabor, Ia., where he will continue his father's business.

1 2 3 4 5 6 7 8 9 0 1 9 0 8 A B C D E F G H I J K

Alphabet and Figures
FOR CLASS RINGS, EMBLEMS, ETC..

HERPERS BROTHERS,
SETTING MANUFACTURERS,
Newark, N. J.,

1908

1908 A B C D E F G H ETC. 1908



A Small Compound Sand Blast

Price, \$20.00 Foot Bellows, \$6.00

WORKS AS EFFECTIVELY WITH FOOT BELLOWS AS WITH POWER BLOWER

MADE of Galvanized Sheet Iron, 10 inches diameter, Glass Top, Fittings of Brass and Iron, practically indestructible. Satisfaction guaranteed. Ask your Jobber for it, or write to us. Other Specialties: Zeuner's Best Jewelers' Saws; American Swiss Files, equal to the best imported; Gas Furnaces, for Melting, Annealing, etc., etc.; Positive Pressure Blowers.

E. P. REICHELME & CO.
JEWELERS' TOOLS, FILES AND SUPPLIES
24 JOHN STREET, NEW YORK

The "SECURITY" Necklace Clasp



HEAR IT SNAP
Absolutely Secure and Simple. Cannot Pull Out
LOCKS IN TWO PLACES
Making it Doubly Secure
The Only Perfect Clasp
Ask Your Jobber or Write.

PRICES TO THE TRADE:

No. 1	No. 1.	10-Karat,	- -	\$6.00	doz.
	1-B.	10 "	- -	7.00	"
	1.	14 "	- -	7.00	"
	1-B.	14 "	- -	9.00	"
	2.	10 "	- -	9.00	"
	1.	Platinum,	- -	18.00	"
	1.	Gold Filled,	- -	2.00	"
	1-B.	" "	- -	2.25	"
	2.	" "	- -	2.50	"
	1.	Sterling Silver,	- -	2.00	"

The Hoffman Novelty Co., Makers, 79-83 No. Pearl St., ALBANY, N. Y.

"CLINCH"



Safety Catch for Scarf Pins
Does not mar the pin. Nothing to get out of order. Simple and neat.
One turn to the right grips like a vise.
..FITS ANY SIZE PIN..

Patent applied for.

PRICES TO THE TRADE
No. 1 Gold Plated \$1.50 doz.
No. 2 Roman Gold 2.00 doz.
No. 2 14k C'ld Pl'te 2.25 doz.

No. 1, 25c.

LEIMAN BROS.'
NEW AUTOMATIC, CONTINUOUS-FEED
SAND BLAST \$15.00
May be operated with Foot Bellows or a Pressure Blower
SHORT, STRAIGHT SAND FEED PIPES prevent loss of energy and insure a free flow of sand
EASY TO OPERATE—EASY TO UNDERSTAND
Get our literature about Sand Blast Machines on request

145 Brill St., NEWARK, N. J. **LEIMAN BROS.** 141 Centre St., NEW YORK, N. Y.
Manufacturers of JEWELERS' MACHINERY and BENCHES

Importer and Manufacturer of
WATCH MATERIALS, TOOLS, JEWELERS' SUPPLIES AND OPTICAL GOODS



Bargains in
Staking Tools
Prices on Application

Fine Gold, Silver and Platinum always on hand.
Highest Prices paid for Old Gold and Silver.

A. ZAREMBOWITZ
250 East Houston Street NEW YORK

ESTABLISHED 1886 **GEO. M. BAKER** TELEPHONE UNION 1493-R
Gold and Silver Refiner and Sweep Smelter
Office, 91 Page St. } PROVIDENCE, R. I. Our processes are strictly up to date and facilities most complete for doing all kinds of refining. }
Works, 77-85 Page St. } Specialties: Prompt and good returns.

PLATINUM AMERICAN PLATINUM WORKS
NEW YORK OFFICE 41 Cortlandt Street NEWARK, N. J.



WORKSHOP NOTES AND QUERIES

[Answers are also solicited from our readers to the questions published on this page.]

QUESTION No. 2103.—**Packfong.**—*What is packfong, and what are its uses?*

C. R. D.

ANSWER:—Argentan, or packfong, is an alloy consisting of 60 parts of copper, 20 parts of pure nickel, and 20 parts of zinc. This alloy possesses a fine white color with a slight yellow cast in it. This is the alloy extensively used for watch movements. It is harder to work in drilling and turning than good brass, and the oil is not so well preserved in contact with it; therefore brass bushes for the pivots are recommended.

QUESTION No. 2104.—**Oxidizing Brass Containing Zinc.**—*How can I oxidize a number of small brass articles which contain zinc?*

H. & Co.

ANSWER:—Brass that contains a large percentage of zinc in its alloy is more difficult to oxidize than a brass containing a larger percentage of copper. Therefore an oxidizing solution that works satisfactorily with one kind of brass will not give the same result with a slightly different alloy. The three oxidized pieces inclosed were treated with a solution of verdigris, one-half pound; ammonia, one quart, used hot. It will not be necessary to string or handle the pieces separately, but a few hundred should be placed in a wire basket and first potashed in order to remove all the grease or oil that may adhere to them. Rinse off in water, then place the basket with the pieces directly into the heated oxidizing solution. Let remain long enough until the desired color is obtained, then rinse in hot water and dry in sawdust. The oxidizing solution should be put into an enameled dish, large enough so that the dipping basket can be placed therein. It is best to have a small flame under the dish to keep the solution at the near boiling heat. During the coloring the basket may be taken out a few times and shaken so that the pieces will change positions. This will insure their being thoroughly colored. A solution of one or two quarts is all that is necessary for oxidizing thousands of the pieces, and if there are two dipping baskets one basket can be prepared while the other is coloring. The coloring operation requires about five minutes. The solution will need replenishing when it begins to work slowly, especially in ammonia, which will evaporate.

QUESTION No. 2105.—**Removing Dirt from Gold Filings.**—*Kindly favor me with the best method of removing dust and dirt from gold filings.*

J. P. B.

ANSWER:—This may be done by wrapping the mixture in stiff wet paper and melting the gold on a charcoal with some borax.

QUESTION No. 2106.—**To Drill Porcelain.**—*I want to drill some holes through hard porcelain plates. What kind of drill must I use?*

T. D.

ANSWER:—For drilling holes through porcelain use a well-tempered flat drill. Grind the drill cutting edges a little straighter across so there will be less biting edges than are used for metal. The drill should be turned with a hand drill and lubricated with a little turpentine or glycerine.

Metallizing Non-Metallic Objects.

AFTER six years of laborious research and experiments, reports Consul-General Geo. W. Roosevelt, of Brussels, Belgium, H. Monge and C. Arzano have succeeded in perfecting the art of metallizing non-metallic substances, and recently established a factory at 17 Rue d'Irland Saint-Gilles, Brussels, for the manufacture of bronze plated art objects, ancient and modern. By their process, the secret of which they jealously guard, they are enabled to metallize even so delicate a thing as lace or a rose in full bloom.

The object of this establishment is to place handsomely finished metallized objects on the market, in every particular equal to, but at one-eighth the cost of cast bronze, and to immutably fix the incomparable forms nature gives to her products, such as flowers, leaves, fruits, insects, etc. These the most skilful have heretofore only furnished fair imitations by covering the object by electrolytic means with an exceedingly thin but as dense as possible coating of brass, which transforms the natural objects into bronze.

Without disclosing secret methods of metallizing, no hesitancy was observed concerning a description of the length of time that objects were retained in what is known as the bath. The length of time varies according to the character of the object, and the complication of its detail, from 24 to 72 hours. The subjects selected for metallizing are generally well-known works of famous artists, objects for decorative purposes, and artistic objects, such as card and ash receivers, frames, etc.

The finished articles, which resemble in weight, texture, color, etc., real bronze, are entirely different from any manufacture now on the market, as they are declared chemically pure copper and not a mixture or composition.—*The Brass World.*

Mack A. Hurlbut, Fort Dodge, Ia., has just completed extensive improvements in the interior of his store.

Solution of Platinum in the Preparation of Chloride of Platinum.

THE first proceeding in the oxidization of silver with the aid of platinum, says a writer in a foreign exchange, consists in the preparation of a solution of chloride of platinum, which is obtained by the solution of metallic platinum in aqua regia (or nitro muriatic acid), a mixture of one part of nitric acid and three parts of hydrochloric acid, just as we treat gold in aqua regia in the production of chloride of gold. The success of the process depends largely on the purity of the platinum employed. Most of the commercial platinum contains iridium, in the proportion of from 1 to 10 per cent.; this tends to make the platinum harder.

Pure platinum is very soft and not adapted for many purposes. If it contains iridium, however, it is harder, and according to the quantity of iridium introduced, we can obtain softer and harder platinum. Inasmuch as iridium is more highly resistant than platinum, the alloy obtained in this manner can be used for most purposes for which platinum is employed. In the goldsmith industry, however, platinum that is free from iridium is always used. If the latter metal contains iridium, it will be the more difficult of solution in aqua regia; some kinds, for instance platinum-iridium wire, only dissolve with great difficulty and days may elapse before all the metal is dissolved. Other kinds are very rapidly dissolved.

We call especial attention to this circumstance so that those who propose to make their own chloride of platinum may be informed, in case the metal fails to dissolve. We must, therefore, obtain as pure a platinum as possible. If it is impossible to obtain this, it is better to purchase chloride of platinum solution ready made.

Place about 28.4 parts (grammes) of platinum in the form of sheet cuttings in a flask of about 900 parts (grammes) capacity, and pour onto the metal 170 (grammes) parts of concentrated hydrochloric acid and 57 parts of concentrated nitric acid. Now heat the flask, but not quite to the boiling point. The platinum will then begin to dissolve and strong, red vapors (nitrous acid vapors) will develop and ascend.

If the reaction ceases suddenly, it is a sign that more acid is required; we, therefore, add more acid, say: for three parts hydrochloric acid, one part of nitric acid. If pure platinum has been used, the above quantity of acid will suffice for its solution.

After all the platinum has been dissolved, the fluid must be poured into a porcelain evaporating dish and evaporated, at moderate heat, until all the acid has been driven off and chloride of platinum remains. We know that this has been effected when the solution turns a pronounced dark red and assumes a syrupy consistency. It must not be evaporated to dryness.

The new store of P. H. Boyson Jewelry Co., S. 3d St., Cedar Rapids, Ia., was formally opened to the public about a week ago. The store has been handsomely furnished and decorated.

C. DORFLINGER & SONS

36 MURRAY STREET

NEW YORK



Hand-Made Blanks only.
Cut, engraved and etched
glass. Light, medium
and heavy stemware,
tumblers, etc.

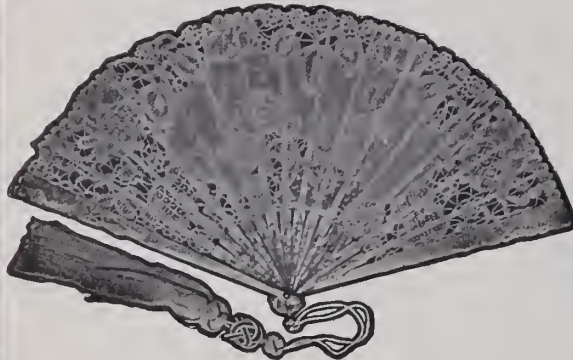

My Stock

of exquisite and unusual
effects in FANS is, as
usual, the Most Complete
in this country.

Louis Steiner

FANS And Novelties for
the Jewelry Trade

520 and 522 Broadway
New York

OWANDA CUT GLASS CO.

Manufacturers of

RICH CUT GLASS



Originators of
New Designs

Honesdale,
Pennsylvania

No. 1088. 3 Piece Compot

A Complete line of our high-grade goods
shown at our

New York Office, 68 West Broadway

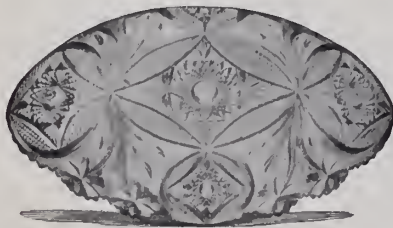

"Wild Rose," No. 122—14-inch
Ice Cream Tray

Irving Cut Glass Co. Inc.

Manufacturers of

Artistic Cut Glass

HONESDALE, PA.

F. W. REICHENBACHER
New York Representative
No. 25 WEST BROADWAY, Room 43

CROUCH & FITZGERALD



Jewelry Trunks and Cases

177 Broadway,
Bet. Cortlandt
and Dey Sts.
688 Broadway,
723 6th Ave.,
New York.

Established 1879

Manufacturer of

LOUIS W. HRABA Fine Leather Goods

29 East 19th St., New York

Exclusively for the Jewelry Trade



LEMAIRE OPERA GLASSES

LEMAIRE FIELD GLASSES

Best in the World. Used in the Army and Navy.

SUSSFELD, LORSCH & CO., Importers

37 MAIDEN LANE, NEW YORK

MARQUE DE FABRIQUE



All Genuine Glasses
Bear This Mark
Large Variety in All
the Latest Styles

THE CONNOISSEUR



Devoted to Art Pottery, China, Marbles, Bronzes, Cut and Decorated Glass Ware, Bric-à-Brac, Lamps, Art Metal Wares, Fancy Goods and Kindred Lines.

AUSTRIAN PORCELAIN AND VIENNA WARE.

(J. A. R. in the *Canadian Pottery and Glass Gazette.*)

(Continued from issue of March 25.)

It was before the Sorgenthal administration that the Vienna factory forsook the antique style of decoration and adopted the antique which the recent discoveries at Pompeii had brought into public favor. This change had an important effect on the productions of the factory, which, instead of following in the wake of Meissen and Sevres as it had done hitherto, struck out an entirely new scheme of decoration peculiar to itself in its treatment of the antique, and placed itself on level terms with the most illustrious of its rivals by the triumphs it achieved.

After 21 years' service as director, Baron von Sorgenthal died on the 17th of October, 1805, and on the 25th of the same month Matthaus Neidermayer was appointed his successor. Neidermayer, who had worked in the factory through the entire period of Sorgenthal's directorate, made no changes in the system and the first 10 years of his management may be included in the most flourishing period of the factory's existence. Neidermayer's successful administration was carried on under considerable difficulties. Austria was involved in war and her financial credit drained. In 1809 Napoleon's army occupied Passau, the district in which was situated the branch factory, as well as the porcelain clay beds, upon which Neidermayer relied for the greater part of his material. He was therefore obliged henceforth to get his clay from Bohemia and Hungary. In spite of these grave disadvantages the factory continued to flourish and increase its output, until 1816, after which year the factory steadily declined.

The general decadence of artistic feeling which was so noticeable in the early years of the 19th century, the introduction of machinery, and the difficulty of competing with the numerous small factories which were springing up all over the country, were all factors which helped to bring about the ultimate cessation of the Vienna porcelain works. Owing to the general stagnation of trade brought about by the long wars, people were unable to afford the luxury of artistic surroundings in their homes, a circumstance which made it necessary for the factory to devote itself to the production of ware of a more useful order. It is possible, however, that with all these drawbacks Vienna might have been able to hold her own, if Neidermayer had remained true to the traditions of his predecessor, Sorgenthal;

but as he advanced in years he appears to have neglected the artistic requirements in favor of the exclusively technical, a policy which resulted in the expensive productions of the factory having no quality but good technical workmanship to compete with the cheaper goods of its rivals.

Nidermayer, who had retired in 1827, and died two years later, was succeeded by Benjamin Scholtz, who continued the policy of neglect of artistic, in favor of technical and economical considerations. He reduced the quality of the ware by the use of a cheap clay from Brinditz, and introduced the use of steam machinery. In spite of these economies, however, he failed to effect any financial improvement, and only produced bad porcelain. The result of this policy was the rapid decline of the prosperity of the factory, which continued till the death of Scholtz in 1833. He was succeeded by Andreas Baumgartner, professor of physics at the university, whose scientific training gave him sympathy with the technical rather than the artistic development of the works.

Baumgartner retired in 1843, and was succeeded by Franz Freiherr von Leithner, the director of the chemical works at Nussdorf, who, however, was unable to stem the declining fortunes of the factory, although efforts were made to represent it at the great Exhibition of 1851, in London. After Leithner's death in 1854, there was no director till 1856, when Alexander Lowe was appointed. He attempted to revive the artistic traditions of the factory, but both the materials and the feeling of the period were against him. He, however, attained a certain amount of success. But the factory was in a moribund condition, and in 1864 it finally ceased work by order of the Government.

The production of the Royal Vienna porcelain factory are very keenly sought after on the continent at the present time. Those dating from the period of Sorgenthal and of the early years of Neidermayer are rare and command high prices, a circumstance which has given birth to a considerable industry in forgeries and imitations.

(THE END.)

E. K. Hall, Gouverneur, N. Y., has just completed the remodeling of the interior of his establishment. He has added new wall cases and a sitting room for the convenience of waiting customers.

Gold Cup Presented to Baltimore, Md., Firm on Fiftieth Anniversary.

THE illustration herewith shows the gold cup recently presented to Hutzler Bros., Baltimore, Md., by their employes, the occasion being the 50th anniversary of the firm. The store on Howard St. was beautifully decorated all of the week in honor of the occasion, and they were in re-



CUP PRESENTED TO BALTIMORE, MD., FIRM ON ITS 50TH ANNIVERSARY.

ceipt of some handsome floral remembrances from other merchants.

The cup was designed by the Samuel Kirk & Sons Co., Baltimore, and is 14 inches high, resting on an ebony base. It is of classical design and has three handles, on which are worked parts of plants, the product of which enter into the manufacture of articles sold by the firm. In the spaces are depicted the first building used and the present structure. In the remaining space is a wreath joined at the top by the firm's monogram, which incloses a suitable inscription.

P. H. Sperry, Marinette, Wis., has moved into new quarters in the old post-office site.



The All-Black Team

Bright Overglaze Enamel Colors

The latest production of the *Royal Doulton* factories. Exquisitely enameled in rich colors.

— — —

Sole Agent

W.S. Pitcairn

44 Murray Street
New York

Write for Booklet, "Quaint Bits of Royal Doulton"

THE ALL-BLACK TEAM
SERIES No. D2864



JOSEPH IRONS
NEW YORK, N.Y.

LA VIGNE TEASPOON

LA VIGNE TABLESPOON

LA VIGNE MED. FORK

The latest and newest in **ROGERS FLATWARE**

HAVE YOU SEEN IT?

Bright or French Gray. Sample dozen on approval. Write for prices and terms.

JOSEPH IRONS, 35 Maiden Lane

The **St. James**

Cor. Walnut and 13th Sts., Phila., Pa.

THE IDEAL HOTEL OF THE QUAKER CITY

A spacious fire and burglar proof safe has been provided for the convenience of the trade. Palatial rooms with bath \$2.50 per day and up. Rooms without bath, (running water) \$2.00 and up.

EUGENE G. MILLER, Mgr.



TRADE MARK ESTABLISHED 1850

HAND BAGS

We have a very extensive collection in all desirable leathers

C. F. RUMPP & SONS
FINE LEATHER WARE

Fifth and Cherry Streets
PHILADELPHIA

New York Salesrooms, 683 and 685 Broadway

Correspondence Solicited



ELK TEETH
CUT GEMS
ROUGH GEM MATERIAL
CLAWS OF LION, LYNX
CAT, EAGLE, OWL, HAWK

Any of above sent on selection responsible Manufacturers, Jewelers or Lapidaries.

Price Lists. Strictly wholesale price

L. W. STILWELL
DEADWOOD - - SOUTH DAKOTA



HERMAN KOHLBUSCH, Sr.,
ESTABLISHED 1859.

Manufacturer of Fine Balances and Weights for every purpose where accuracy is required.

Office and Salesroom, 194 BROADWAY, NEW YORK.
Send for Price List. Tel. 370 Cortlandt.



WM. BOLLES' SELF-FILLING NON-LEAKABLE FOUNTAIN PEN.



SIMPLE—CLEAN—PRACTICAL

We make our own goods—and they have stood five years' test by the largest dealers in the country. Write for Catalogue and Price Lists.

THE WM. BOLLES CO., 1108 JEFFERSON ST., TOLEDO, OHIO

BUYERS' INFORMATION BUREAU

Questions as to the makers of certain lines of goods, where to buy certain lines, where certain kinds of work are done, the owners of certain trade-marks and other matters relating to the buying branch of a jewelry business will be cheerfully answered under this department. *All queries are also answered promptly by mail.*

NEWPORT, R. I., Feb. 27, 1908.

Editor of THE JEWELERS' CIRCULAR-WEEKLY:
Kindly let me know the address of the Superior Silver Co.?

O. L. R.
ANSWER:—"Superior Silver Co." was a mark used by the Middletown Plate Co. (International Silver Co., successors), Meriden, Conn.

MORRISVILLE, Vt., Feb. 6, 1908.

Editor of THE JEWELERS' CIRCULAR-WEEKLY:
Kindly let us know the address of the makers of Moore's non-leakable pen.

F. H. B.
ANSWER:—American Fountain Pen Co., 168 Devonshire St., Boston, Mass.

ALBANY, N. Y., March 17, 1908.

Editor of THE JEWELERS' CIRCULAR-WEEKLY:
Can you furnish us with the address of the Plato Clock Co.?

F. W. H.
ANSWER:—The Plato clock is made by the American Electrical Novelty & Mfg. Co., Spring and Hudson Sts., New York.

WATERBURY, CONN., Feb. 10, 1908.

Editor of THE JEWELERS' CIRCULAR-WEEKLY:
Please inform me where I can purchase celluloid?

F. G. R.
ANSWER:—The Celluloid Co., 30 Washington Pl., New York.

FREDERICKSBURG, Va., Feb. 19, 1908.

Editor of THE JEWELERS' CIRCULAR-WEEKLY:
Kindly send us the name and address of the maker of Victory screw backs for emblem buttons?

M. & H.
ANSWER:—Gebhardt Bros., Lions building, Cincinnati, O.

MT. KISCO, N. Y., Feb. 26, 1908.

Editor of THE JEWELERS' CIRCULAR-WEEKLY:
Will you kindly give me the name of a firm who makes or sells translucent paper signs?

S. K. S.
ANSWER:—Caesar Bros., 112 Fulton St., New York.

GALESBURG, Ill., Jan. 15, 1908.

Editor of THE JEWELERS' CIRCULAR-WEEKLY:
Can you inform us where we can obtain high class enameled jewelry on silver?

C. & A.
ANSWER:—I. Emrich & Co., 42 E. 14th St., New York, and D. Lisner & Co., 140 Fifth Ave., New York.

JOLIET, Ill., Jan. 8, 1908.

Editor of THE JEWELERS' CIRCULAR-WEEKLY:
Can you tell me the address of the firm manufacturing transfer letters, numerals and ornaments for use on metal and inside of glass?

J. S.
ANSWER:—Caesar Bros., 112 Fulton St., New York.

NEW LONDON, Conn., Jan. 16, 1908.

Editor of THE JEWELERS' CIRCULAR-WEEKLY:
Can you refer us to anyone who has suitable books for recording watch movements bought or sold?

P. & S.
ANSWER:—W. Green & Co., 81 Nassau

St., New York, and M. Sickles & Sons, 726 Chestnut St., Philadelphia, Pa.

MILWAUKEE, Wis., March 25, 1908.

Editor of THE JEWELERS' CIRCULAR-WEEKLY:
Can you tell me where I can get a glass bead necklace, the gold being on the inner side, which prevents the neck from discoloring?

G. D.
ANSWER:—American Bead Co., 525 Broadway, New York.

WASHINGTON, D. C., Feb. 28, 1908.

Editor of THE JEWELERS' CIRCULAR-WEEKLY:
Kindly inform me of whom I can procure solid gold and enamel lockets or miniature brooches, viz., round brooches in which a photo or miniature can be inserted?

J. H.
ANSWER:—E. F. Foley, 281 Sixth Ave., New York.

OSWEGO, N. Y., Feb. 20, 1908.

Editor of THE JEWELERS' CIRCULAR-WEEKLY:
Can you furnish us the address of some one who deals in spirit compasses?

A. J. K.
ANSWER:—John Schroeder Co., 192 New Water St., New York.

BOSTON, Mass., Feb. 10, 1908.

Editor of THE JEWELERS' CIRCULAR-WEEKLY:
Who bought the dies, etc., of the A. F. Dowle & Son Co.?

N. Co.
ANSWER:—Rogers, Lunt & Bowlen Co., Greenfield, Mass.

HAMILTON, O., Feb. 7, 1908.

Editor of THE JEWELERS' CIRCULAR-WEEKLY:
Will you kindly give us the address of parties who handle cuckoo mantle clocks with spring movements?

B. B. Co.
ANSWER:—Bawo & Dotter, 30 Barclay St., New York; American Cuckoo Clock Co., Philadelphia, Pa.

GRAHAM, N. C., Jan. 30, 1908.

Editor of THE JEWELERS' CIRCULAR-WEEKLY:
Will you please give me the name and address of a firm which makes a specialty of cast iron legs for show cases?

Z. T. H.
ANSWER:—Barnett Bros., 105 Hamilton St., Newark, N. J.

GREENVILLE, Tenn., Feb. 21, 1908.

Editor of THE JEWELERS' CIRCULAR-WEEKLY:
Will you please tell us the manufacturers of a spoon called the "Frontenac," made in sterling silver?

L. & Co.
ANSWER:—Simpson, Hall, Miller & Co., Wallingford, Conn.

ROCKFORD, Ill., Feb. 22, 1908.

Editor of THE JEWELERS' CIRCULAR-WEEKLY:
Can you tell me who makes secret wedding rings?

J. E. R.
ANSWER:—If the ring you refer to is made in two parts on which an inscription may be engraved and then locked together we should refer you to J. B. Bowden & Co., 1 Maiden Lane, New York, or Leonard Krower, New Orleans, La.

NEW YORK, Feb. 17, 1908.

Editor of THE JEWELERS' CIRCULAR-WEEKLY:
Can you inform me as to a clockmaker named John Calver, Woodbridge, England?

A. G.
ANSWER:—John Calver, a master clockmaker, lived at Woodbridge, England, in the year 1750.

NEW YORK, Feb. 19, 1908.

Editor of THE JEWELERS' CIRCULAR-WEEKLY:
Where can we obtain small balls from 1/16 inch in diameter to 1/4 inch, made from feldspar or alabaster?

F. W. G.
ANSWER:—American Bead Co., 525 Broadway, New York.

T. E. Coffman, Toronto, Kans., will open another store in Rocky Ford, Colo.

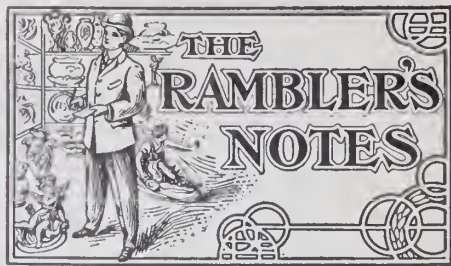

ARTISTIC SUBJECTS IN BRONZES

ONE of the attractive bronze exhibits seen at the New York salesrooms of the Gorham Co. is "Pan and Cupid," by Isidore Konti. The two figures rest on a rough base, and are grouped with Pan behind and leaning over Cupid, grasping one of the little god's arms. Cupid holds in one hand his bow, and his quiver filled with arrows is slung over his shoulder. Another subject shown at the same place is entitled "Day Dreams," and is the work of Bessie Potter Vonnoh. The study shows a wide sofa on which are seated two women. One holds in her lap an open book. Both are reclining in an easy position. The draperies and pillows on the sofa are fine examples of perfect detail work in sculpture of this kind.

A NEW LINE OF CUT GLASS.

AT the new salesroom of Joseph Irons at 35 Maiden Lane, New York, there is now on exhibition an attractive line of cut glass, including a variety of offerings of interest to jewelers, and the new salesroom affords an adequate opportunity to display this glass to the best advantage. Included in the display is a bowl with trellis work cutting and other artistic decorative features. In the manufacture of this dish three wheels of different gauges were required to produce the trellis work effect, owing to the shape of the bowl. Other pieces of different shapes are shown with the same style of cutting, and include dainty dishes of various sizes. One piece, a fruit dish, was cut in such a way that it had rough points over its outer surface. Other offerings include dainty bonbon dishes, trays, fruit baskets and vases. The cut glass firms represented by Mr. Irons are the O. F. Eggenton Co. and the Corning Cut Glass Co.

WEDGWOOD CHINA AND OTHER LINES.

A DAINTY china strawberry set is on exhibition at the salesrooms of Josiah Wedgwood & Sons, 25 West Broadway, New York. It consists of a tray, sugar bowl, cream pitcher and berry saucer, all of which are decorated in acid gold with flowers shown in their natural colors against a background of green leaves. This same firm is showing a dainty water set consisting of a pitcher, candle holder and match box, all of which are hand painted in floral designs. The line of black basalt for which the Wedgwood firm has long been famous is also an attractive feature at these salesrooms. Pieces of different sizes and shapes are shown decorated in gold and bronze.

THE RAMBLER.

A SHEAR

that will cut any kind of design to perfection. Better have a pair—they are mighty useful.

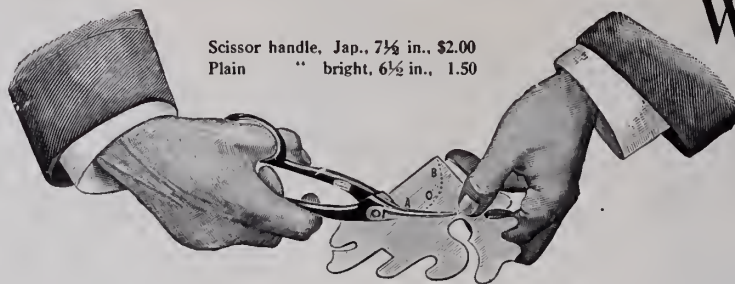

Scissor handle, Jap., 7½ in., \$2.00
Plain " bright, 6½ in., 1.50

William Dixon,

Incorporated

39 John St., New York

Formerly

F. W. GESSWEIN COMPANY



Enough metal is often lost in the careless reduction of

Filings, Waste, Scraps and Sweeps

to cover the cost of the work. We are careful and considerate enough to overcome this loss, thus enabling you to meet the expense out of a surplus that is ordinarily lost.

Try us and see if it isn't so

No. 236 Eddy St., **CONLEY & STRAIGHT,** Providence, R. I.

Gold and Silver Refiners, Assayers and Sweep Smelters, Dealers in Fine Gold, Silver and Platinum, all kinds of Gold and Silver Anodes.

WM. F. RENZIEHAUSEN CO.

'Phone 3759-R.

43-47 Oliver Street, NEWARK, N. J.

Gold and Silver Refiners

PROMPT RETURNS MADE FOR ANY MATERIAL CONTAINING PRECIOUS METALS
DEALERS IN GOLD AND SILVER, AND ROLLERS OF STERLING SILVER.

Gold and Silver Anodes a Specialty

Frank Dederick.

Established 58 Years.

James E. Dederick

James H. Dederick's Sons, Assayers and Bullion Dealers.

All qualities of Gold and Silver, in Plate, Square and Round Wire, Rolled to any gauge. We are selling fine gold for \$1.04 per dwt, which we guarantee to be government assay bars. Small rolling for the trade.

ALL QUALITIES OF GOLD AND SILVER SOLDER.

16 Maiden Lane

NEW YORK.

We buy Old Gold and Silver.

CRUCIBLES.

Jewelers' Supplies,
Etc.

Established 1850.

J. & H. BERGE,
95 John Street,
NEW YORK.



PRACTICAL COURSE IN ADJUSTING

Published Price, \$2.50.
Special Reduced Price, \$1.50, Postpaid



WE BUY

Old Gold and Silver Filings, Polishings, Sweeps, Hand Washings, etc. We will make accurate valuations and hold consignment subject to your acceptance. If valuation is not satisfactory, we reship to you at our expense.

WE PAY FOR OLD GOLD:

22 K. 88c. per dwt.	12 K. 48c. per dwt.
20 K. 80c. " "	10 K. 40c. " "
18 K. 72c. " "	8 K. 32c. " "
16 K. 64c. " "	6 K. 24c. " "
14 K. 56c. " "	4 K. 16c. " "

MARKET RATES FOR SILVER AND PLATINUM.

Try us and you will appreciate our Squareness, Promptness and Accuracy.

T. B. HAGSTOZ, Ltd., Main Office, 709 Sansom St., Philadelphia, Pa.
SMELTERS, ASSAYERS, REFINERS.

WE SELL

Gold, Silver and Platinum, various qualities, rolled flat or drawn to wire of any gauge.

PRICES OF ALLOYED GOLD:

8 K. 42c. per dwt.	14 K. 66c. per dwt.
10 K. 50c. " "	16 K. 74c. " "
12 K. 58c. " "	18 K. 82c. " "

Gold and Silver Solder, either from formulas furnished, or our own. "T. B. H." Alloy, 25c. per oz. Guinea Gold, 75c. per lb. Shot Copper, 40c. per lb. We will send tables for alloying without charge. They save figuring.

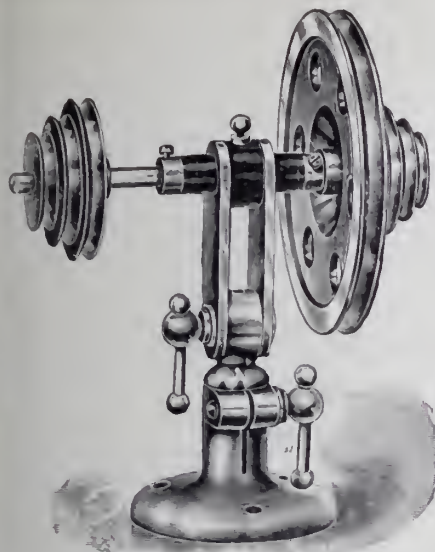

A New Patent Speed Wheel Countershaft

made by G. Boley, all polished and nickel plated, being made with hard bronze bearings which insure perfectly true running, with attachment to hold all wheels for grinding or polishing.

77 John Street,
New York City



Robbins Upright Roller Remover

With Improved Revolving Disk and Plunger

Flat bottom, which sets firmly on the bench. You cannot break pivots with this tool, as it is very easily adjusted for any size from jewel series to the largest size. Single or double roller. Nickel-plated. Price, \$2.25.

ASK YOUR
JOBBER
FOR SAME

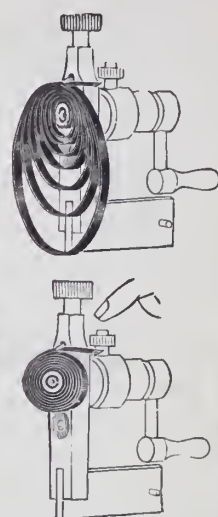
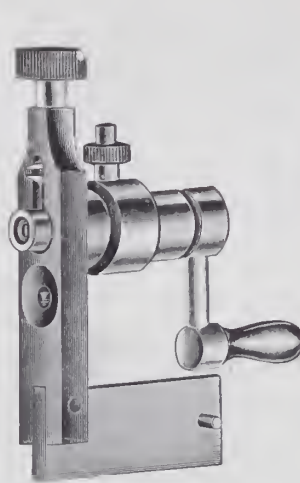

Robbins' Latest Improved Patent Mainspring Winder

Does away with changing of barrels, which alone is a time saver.

Nickel plated, price \$2.00. Directions with each tool.

SOLE AGENTS:

HENRY ZIMMERN & CO., Inc.

Exclusive Wholesale
Distributors for
U. S. and Canada.

ARTHUR MARSON

INC.

MAKERS OF

Swivels, Spring Rings, Snaps and Specialties in the Line, in GOLD and PLATINUM

Manufacturers of the

SMALLEST SPRING RING

on the market for Neck Chains

SEND FOR SAMPLES

23 MARSHALL ST., NEWARK, N.J.

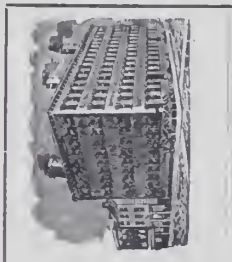

L. LELONG & BRO.

Gold and Silver Refiners, Assayers and Sweep Smelters

S. W. Cor. Halsey and Marshall Sts., NEWARK, N. J.

Prompt attention given to Gold and Silver Bullion.

SMELTING FOR THE TRADE.

JOHN AUSTIN & SON

Assayers, Refiners and Smelters

74 & 76 Clifford Street

PROVIDENCE, R. I.

We Do Our Own Smelting.



CASTINGS

Gold, Silver, Bronze, Brass, German Silver, Copper and Iron.

Supply Jewelers, Silversmiths, Die-makers, Mould-makers, etc. Bronze Forces, Hard Bronze and Iron Shells for Die-cutting Machines. Cast Iron gub for sinking in Steel Dies Chandelier, Undercut Work, Statuary.

AUGUST GRIFFOUL 313 HALSEY STREET NEWARK, N. J.

UNITED STATES SMELTING AND REFINING WORKS

L. & M. WOLLSTEIN

16 JOHN STREET, NEW YORK

SWEEP SMELTERS AND ASSAYERS

Dealers in Gold and Silver Assay Office Bars. HIGHEST and MOST PROMPT RETURNS made for Sweeps and all kinds of Waste containing precious Metals.

HIGHEST PRICES PAID FOR OLD GOLD AND SILVER

Manufacturers of STERLING SILVER.

Importers of PLATINUM.

Ore and Bullion Assays a Specialty.

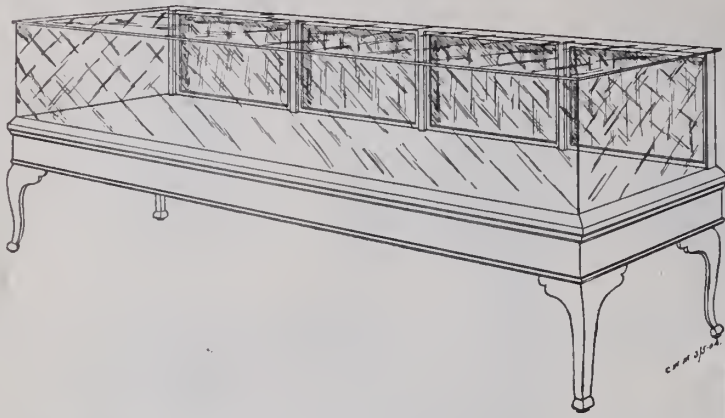

“FOR A QUARTER OF A CENTURY”
 We have been manufacturers of
High-Grade Jewelry
Fixtures

Correspond with us before placing your orders

ALEXANDER H. REVELL & CO.
 Rees, Dayton, Eastman and Hawthorne Streets,
 Chicago, Ill.

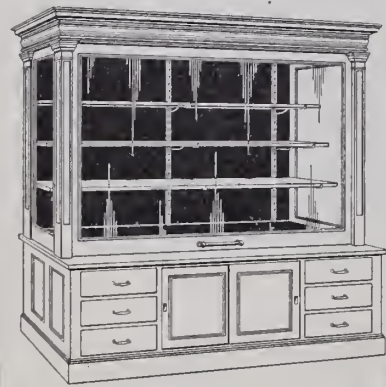

No. 710.

**JEWELERS’
 Store Fixtures**

*Manufactured to please
 the customer*

WADELL SHOW CASE CO.

Department I

DETROIT, MICHIGAN

Write for our New Catalogue

**JEWELERS’
 SHOW CASES.**



Our Small ROSEWOOD MOULDING
 STEEL LINED CASE. We Challenge
 the World to Produce a Better Case.

F. C. JORGESON & CO.

11-17 N. ANN ST., CHICAGO

Makers of all Kinds of

JEWELERS’ FIXTURES

Write for Illustrated Circular

Our Motto: The Best of Everything

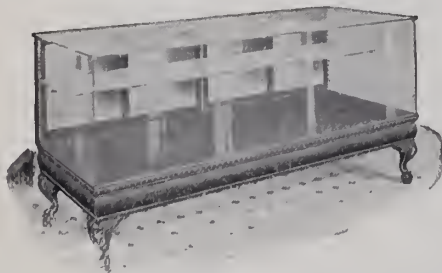

American Beauty Display Case No. 408

UP-TO-DATE FIXTURES

ARE YOUR BEST ASSET.

The Greatest Trade Winner. Let Us Show You.

Our Catalogue “C” shows the latest ideas in
 Modern Jewelry Store Outfitting. Send for it

GRAND RAPIDS SHOW CASE CO.
 GRAND RAPIDS, MICH.

New York Office: 750 Broadway
(same floor as McKenna Bros. Brand Co.) } Under our own
 St. Louis Office: 1331 Washington Ave. } management

The Largest Show Case Plant in the World

JACOT MUSIC BOX CO.

**MIRA MUSIC BOXES
 AND MIRAPHONES**

39 UNION SQUARE - NEW YORK

Practical Course in Adjusting.

Published Price, \$2.50. Special
 Reduced Price, \$1.50. All jobbers,
 or Jewelers' Circular Publishing Co.



Established 40 Years

Every essential quality of piano construction, tone, touch, scale, design, and beauty of finish are combined in the BRIGGS. They are absolutely and unequivocally a standard piano of the world.

Any **SUCCESSFUL JEWELER** can largely increase his profits by the sale of pianos, and many receive the greatest part of his income from selling the

“BRIGGS”

We would like to talk this over with reliable concerns in unoccupied territory.

BRIGGS PIANO CO., Boston

THE

JEWELERS' CIRCULAR

WITH WHICH ARE CONSOLIDATED

THE HOROLOGICAL REVIEW,
THE JEWELERS' WEEKLY,
THE JEWELERS REVIEW

Copyright 1908 by
The Jewelers' Circular
Publishing Company.

11 John St., Corner Broadway, New York.

Entered as second-class matter at the New York, N. Y., Post Office.

40th Year

WEDNESDAY, APRIL 8, 1908.

Vol. LVI., No. 10.



Beautiful Christening Font in the Court Church at Düsseldorf, Germany.

(See Text on Page 35.)

ALVIN SILVER

"ORANGE BLOSSOM"



ALVIN

MFG.

CO.



Butter Knife

Sterling
Silver

The true test of a design in table silver is the effect produced when the table is arranged for formal hospitality.

Pieces of the Orange Blossom design, shown above, make a most attractive group.

This design is made in over one hundred different articles, and is especially suited to wedding gifts.

It is made in sterling silver, stamped with the above trade-mark, and can be obtained from any jeweler, in sets or single pieces, to meet the requirements of complete service.

"BRIDAL ROSE"



ALVIN

MFG.

CO.



Cold Meat Fork

Sterling
Silver

The true test of a design in table silver is the effect produced when the table is arranged for formal hospitality.

Pieces of the Bridal Rose design, shown above, make a most attractive group.

This design is made in over one hundred different articles, and is especially suited to wedding gifts.

It is made in sterling silver, stamped with the above trade-mark, and can be obtained from any jeweler, in sets or single pieces, to meet the requirements of complete service.

The two most appropriate patterns of Sterling Silver Flat Ware for wedding anniversaries. These patterns are being advertised in the leading magazines to stimulate trade, and so the retail jewelers.

These magazines will be read in millions of homes all over the United States.

Be prepared to meet the demand. Complete your stock with fancy pieces and cutlery

ALVIN MFG. CO., Silversmiths, NEW YORK

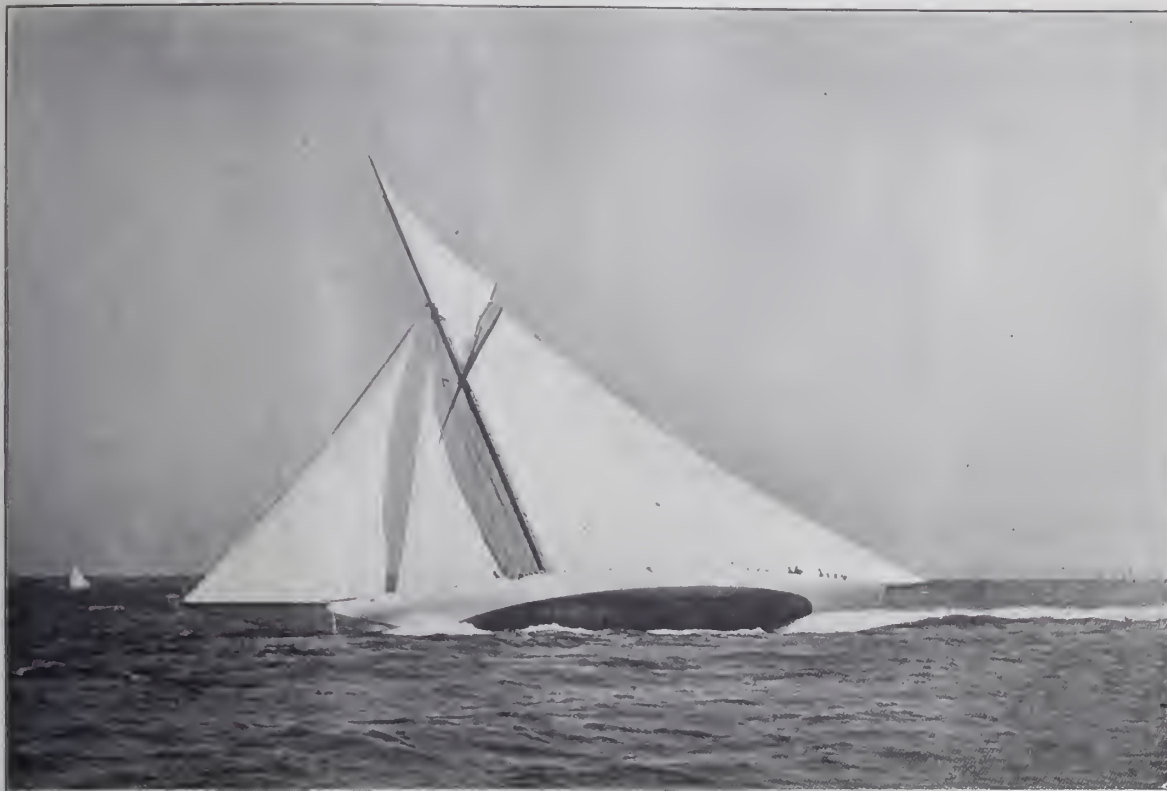

Are you sailing in the right direction by having a full line of

Fahys Bristol Cases

in stock?

So many styles and designs to choose from that every taste must be suited.

There is nothing better made in a 25-Year Case. Why not buy the best?

They win out because of the large "sales."

All made with our patent one-piece pendant, eliminating all solder. This patent is controlled by us exclusively.

JOSEPH FAHYS & CO.

New York

Boston

Chicago

San Francisco

A GENERAL FAVORITE



A general favorite is one whom everybody likes.

Our diamonds are general favorites with those who have seen them.

First, because of the perfection of their cutting, assuring greatest brilliancy, and,

Second, because, we being cutters, there are not two or three profits tacked on to the actual worth of the stones.

J. R. WOOD & SONS

DIAMOND CUTTERS

Importers of Emeralds, Rubies and Sapphires

2 Maiden Lane, Corner of 170 Broadway NEW YORK

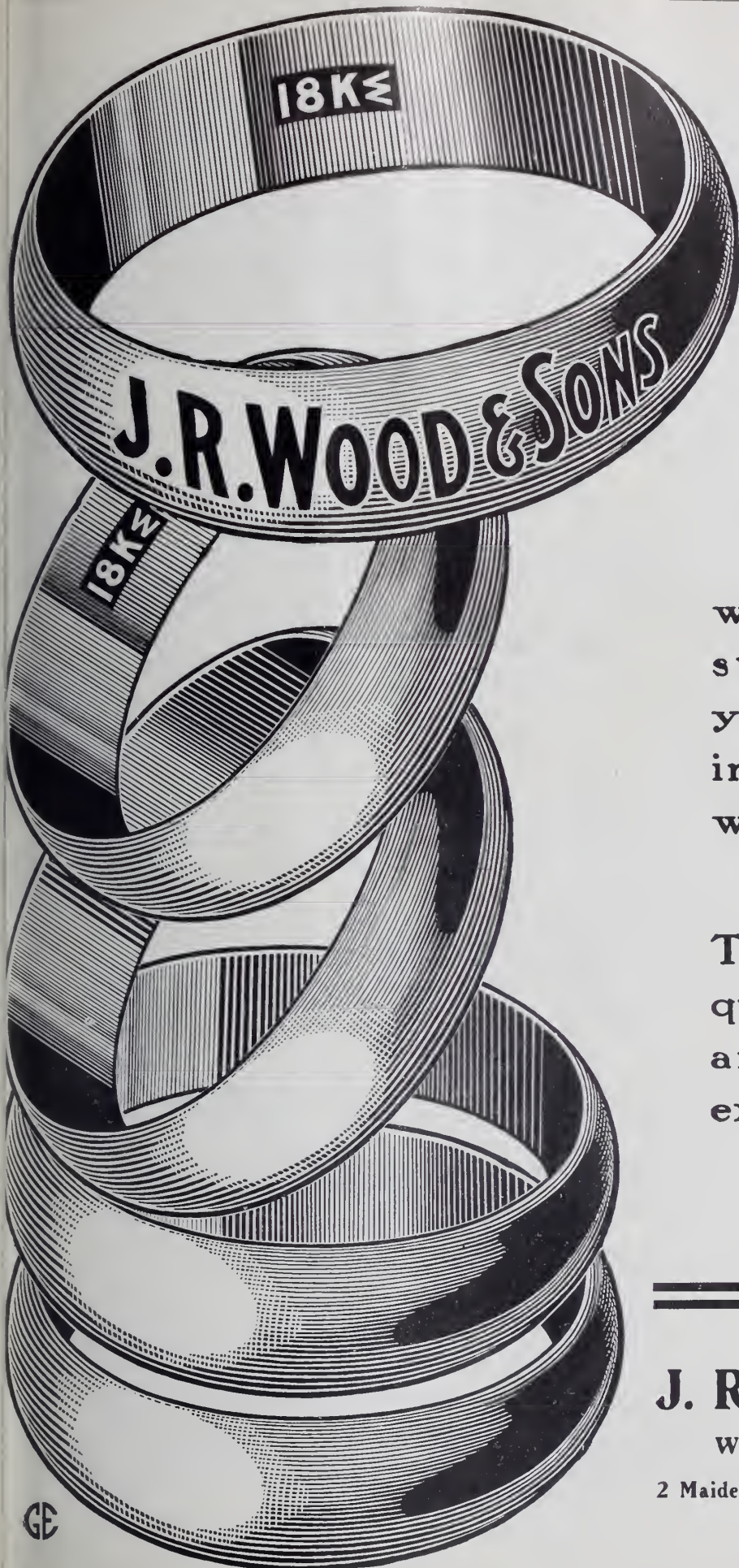

At The Top of the Heap

where they have stayed for **57** years; where we intend them always to remain.

The standard for quality, for finish, and for general excellence.

J. R. WOOD & SONS

WEDDING RING MAKERS

2 Maiden Lane Corner of 170 Broadway

NEW YORK



The Big Dipper

Will Dip Up Profits For You



THE
BEST IN EVERY
GRADE

CHICAGO
701. Heyworth Bldg.

Ask your Jobber

NEW YORK
Maiden Lane

STARWATCH CASE CO.

LUDINGTON, MICHIGAN

COPYRIGHTED BY T. F. KENNEDY.



YOU
 CAN SECURE THAT
 CLASS PIN ORDER
 BY SHOWING
 OUR DESIGNS AND SAMPLES.
 WE ARE HEADQUARTERS.
 WRITE TO EITHER FACTORY.
 WENDELL & COMPANY,
 103 AND 105 WILLIAM ST.,
 NEW YORK.
 57 WASHINGTON ST.,
 CHICAGO.

WENDELL'S PERFECT SAFETY CATCH

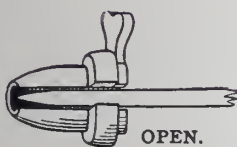

OPEN.

SETS CLOSE TO BODY OF PIN.
 PROTECTS POINT OF PIN TONG.
 HANDILY LOCKED AND UNLOCKED.
 ABSOLUTELY SECURE.

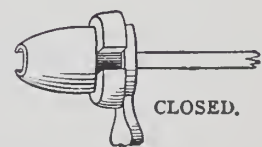

CLOSED.



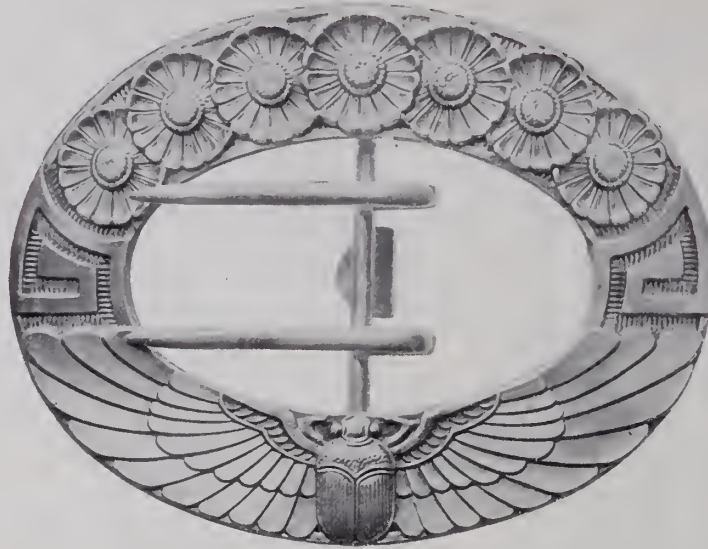

OUR new Buckle and Belt Pin Catalog is now ready and will be sent out in a few days. If you do not receive one, we will gladly send you a copy on request.

We met with such great success with our Buckles that we were encouraged to add from time to time a great many new pieces until we now have as complete and comprehensive a line as any jeweler could desire.

The accompanying illustration suggests one part of the line that we have developed in which is embodied the Egyptian character of ornament.

These Buckles are of heavy weight and no expense has been spared to give them the finest finish possible.

We take this occasion to thank the trade for the support they have given this part of our line in the past and would ask for a continuance of their favors.

R. BLACKINTON & CO.

Established 1861 TRADE  MARK SILVERSMITHS
 FACTORY, NORTH ATTLEBORO, MASS.
 3 Maiden Lane, New York

WHITING MFG. COMPANY



Sterling Silver Vases

ESPECIALLY appropriate for gift purposes at this season of the year in connection with Easter and Spring Weddings.

A timely suggestion will be found by the Retail Jeweler in the attractive series here illustrated, which, though effectively decorative in design, is markedly moderate in price.



No. 893
6½ inches

No. 1893A
8½ inches

No. 2893
10½ inches

No. 3893A
12½ inches

No. 4893
14½ inches

The Whiting Company's line of vases is unusually comprehensive, ranging from examples such as are here shown to special pieces of the most elaborate and ornate character.

BROADWAY AND NINETEENTH STREET

San Francisco, Cal.,
717 Market St.

NEW YORK

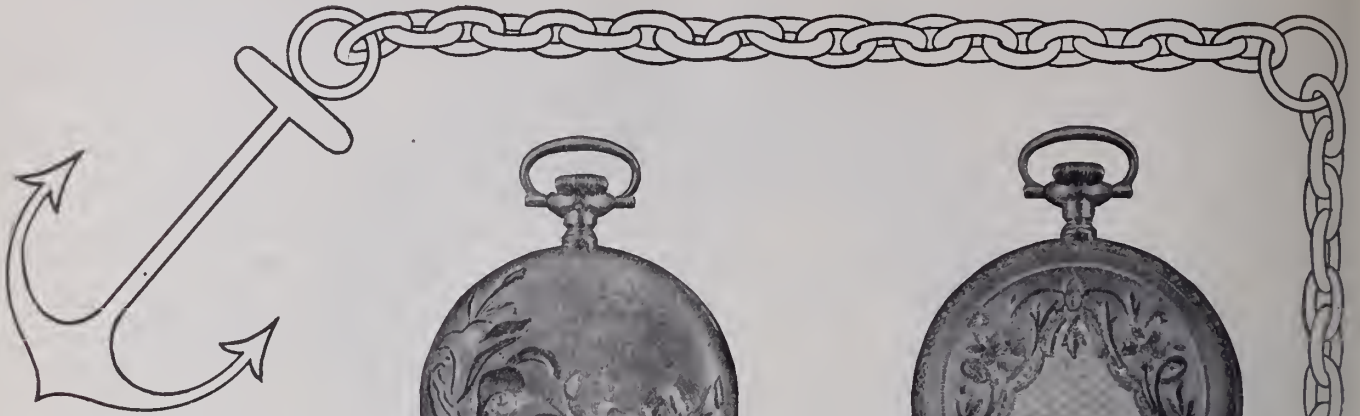

31



32



33



34



35



36



37

12 SIZE
SOLID
GOLD
Dueber Cases
 WHICH ARE SURE
 TO PLEASE.

Spectacle and Eyeglass Strap Plier No. 105

Price, each, \$1.25

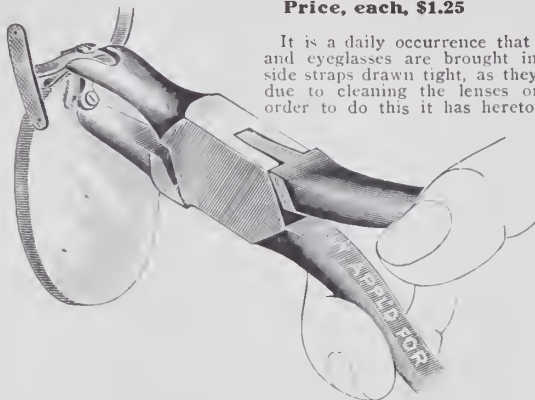

It is a daily occurrence that frameless spectacles and eyeglasses are brought in to have the small side straps drawn tight, as they have become loose, due to cleaning the lenses or other causes. In order to do this it has heretofore been necessary to remove the lenses from the mountings, and as all know, this very often results in breaking or chipping the lenses.

By the means of this plier this can be avoided and the work quickly done.

All that is required is to loosen the screw two or three turns, clamp the frame as shown in the illustration, and bend the straps to the lenses. Retighten the screw, and the work is done.

DO NOT NEGLECT to loosen the screw as otherwise a good job cannot be done, and the lenses are likely to be broken.

Made of best quality Swedish steel, nickel-plated.

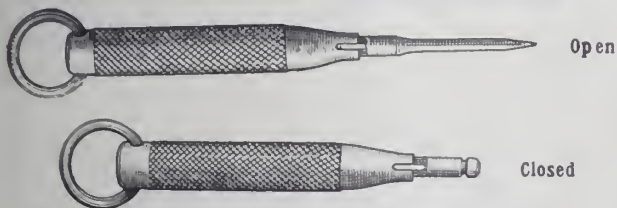

New Charm Eyeglass Screwdrivers No. 110, Reversible Blades, 15 Screwdrivers on a Display Card. Per Card \$1.75.

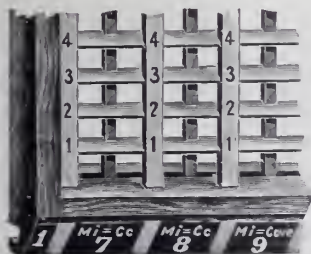

Top View, Showing Skeleton Frame of Drawer. Accumulation of dust and chips is impossible.

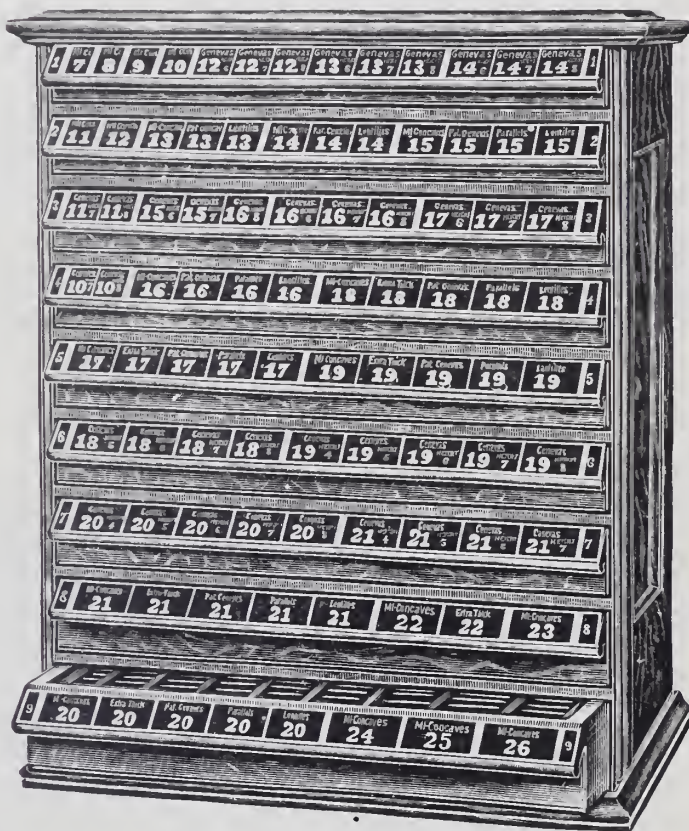

Echarco Watch Glass Cabinet No. 15 (Patented)

Price, each, \$16.00

This cabinet has many new features not found in any other. Novelty and usefulness are the chief arguments in its favor.

CONSTRUCTION AND MATERIAL.—The cases are made of oak, finely finished and of attractive appearance. Sides are paneled. Partitions of basswood and put together in best manner possible.

PARTITIONS are skeleton, preventing accumulation of dust, chips, etc.

BOTTOMS of cabinets are hollow to receive chips, dust, etc.

ARRANGEMENT FOR GLASSES.—The 9 drawers contain 1,547 spaces to hold glasses in upright position.

Labeling of drawers as shown in cut is on the pulls of the drawers and done in gold bronze on black background.

DIMENSIONS.—24 inches wide, 29 1/2 inches high, 12 inches deep; weight, 45 lbs.; with packing case, 75 lbs.

The construction of drawers, the arrangement of partitions to economize space and weight, and the novel method of showing contents on drawer-pulls are all prominent characteristics and extremely well thought of.

FOR SALE BY ALL JOBBERS IN THE UNITED STATES AND CANADA

HAMMEL, RIGLANDER & CO. 47-49 Malden Lane
New York



NEW CONTRIVANCES

STERNAU
Coffee-Machine
with
Sterno-Inferno Burner

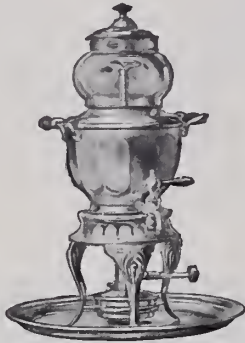

Made in Nickel-plate, Copper
and Silver-plate

are always made to save labor and to better the conditions in every line of business.

The Sternau Coffee-machine saves labor and produces the best flavor of the coffee obtainable.

It does not boil coffee but distils it—thus extracting only the wholesome properties and keeping the beverage free from bitterness.

Connoisseurs will not be without a Sternau Coffee-machine.

As the Sternau Coffee-machine makes coffee superior to the coffee made by any other process it is in demand.

Write to-day for our catalogue showing the different styles and quoting prices.

S. STERNAU & CO.

Makers of

Coffee-machines, Fancy Teakettles, Chafing-dishes and their Accessories, Smoking Sets, Alcohol Stoves, Coffee and Tea Pots, etc.

New York Showrooms
BROADWAY, COR. PARK PLACE
Opposite Post Office

Office and Factory
195 PLYMOUTH STREET
BROOKLYN, N. Y.

If it Burns Alcohol we make it.



WE show herewith a new style bag—an exceptionally strong, stylish, snappy article.

Our new Spring line is complete—covering the entire range of bags—all shapes, all the different styles of mesh—the largest assortment of frames ever shown. Every piece stamped. W. & D. an absolute guarantee of satisfaction.

Your Jobber has them.

WHITING & DAVIS
PLAINVILLE (Norfolk Co.), MASS.

New York Office, 7 Maiden Lane





The Original **Carmen Adjustable Bracelet**

With 20 years' experience and the best factory equipment that can be procured, we are able to produce

THE BEST IN THE WORLD FOR THE MONEY

The stamp, "The D. F. B. Co.," is a guarantee of quality and up-to-date designs. Ladies' and Gentlemen's Chains, Fobs, Lorgnettes, La Vallieres, Hat Pins, Chatelaine Pins and Bracelets.

THE D. F. BRIGGS COMPANY
ATTLEBORO, MASS.

NEW YORK OFFICE
180 Broadway

CHICAGO OFFICE
Heyworth Bldg.

ST. LOUIS OFFICE
Mermod & Jaccard Bldg.

LONDON OFFICE
118-122 Holborn E. C.



"Kotobuki"



(Pronounced Ko-to-bú-ki)

THE JAPANESE WORD FOR LONG LIFE

The Popular Craze in

== SCARF PINS ==

Price in 14 Kt.
\$3.00

MANUFACTURED IN 14 KT. GOLD BY

Price in 14 Kt.
\$3.00

VAN DUSEN & STOKES CO.

MAKERS OF ORIENTAL JEWELRY
IMPORTERS OF CORAL AND SEMI-PRECIOUS STONES

1123 CHESTNUT STREET - - - - - PHILADELPHIA

SOLD DIRECT TO THE RETAIL TRADE ONLY

FEATURES OF OUR LINE

The **UNIQUE, ARTISTIC and UNUSUAL**, together with **BEST WORKMANSHIP, SUPERIOR QUALITY and PERFECTION IN FINISH**

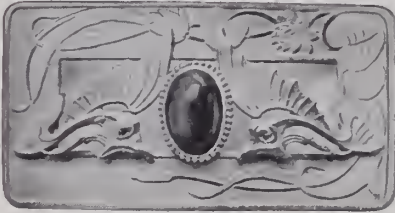

296

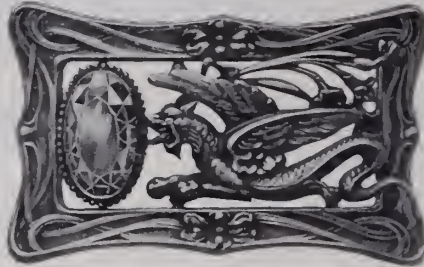

624

SASH BROOCHES
in gold-filled, finished in rose or dark green (antique).

Sash Brooches

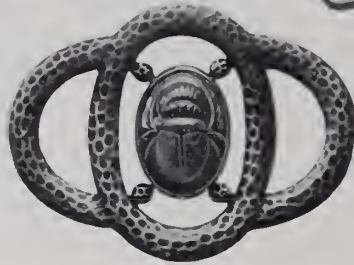

237

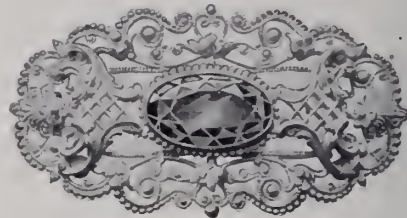

316

We use finest imitation stones and can furnish any stone or color required.

We Manufacture in **GOLD-FILLED** and **STERLING SILVER**

BROOCHES, HAT PINS, COMBS, HANDY PINS, WAIST PIN SETS, BARRETTES, SCARF PINS, VEIL PINS, LINKS, BUCKLES, SASH BROOCHES, BRACELETS and NECKLACES.

C. RAY RANDALL & CO., North Attleboro, Mass.

NEW YORK OFFICE, No. 7 Maiden Lane

SAN FRANCISCO OFFICE, Henry M. Abrams Co., No. 717 Market Street

Address all orders and communications to Factory, North Attleboro, Mass.

NEW YORK, 9 Maiden Lane
CHICAGO, 103 State Street

BATES & BACON ATTLEBORO MASSACHUSETTS

THE LEADING HOUSE FOR HIGH-GRADE GOLD-FILLED CHAINS, LOCKETS AND BRACELETS

Something New for Easter!

THE "WINNA" BRACELETS
Strongest secret joint and catch on the market

SOME OF OUR NEW DESIGNS
ORDER OF YOUR JOBBER

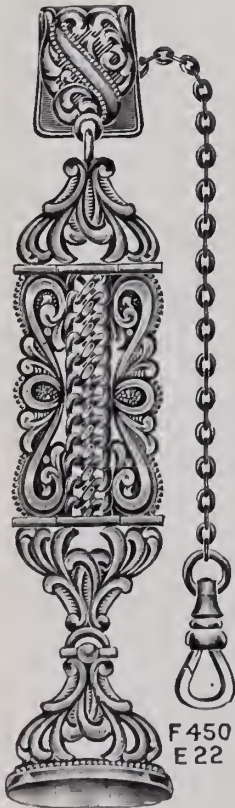

F 450
E 22



L.1261



L.1262



PAT. B. 660
SIZE 7 IN. WIDTH $\frac{5}{16}$ IN.

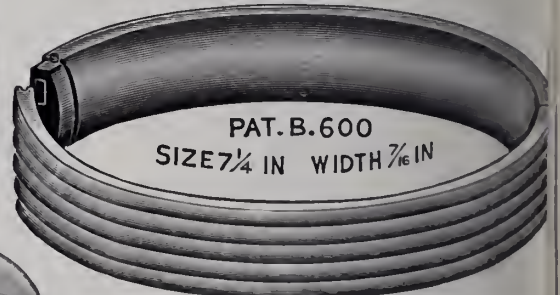

PAT. B. 600
SIZE $7\frac{1}{4}$ IN WIDTH $\frac{7}{16}$ IN



PAT. B. 662
SIZE $7\frac{1}{2}$ IN. WIDTH $\frac{3}{4}$ IN.

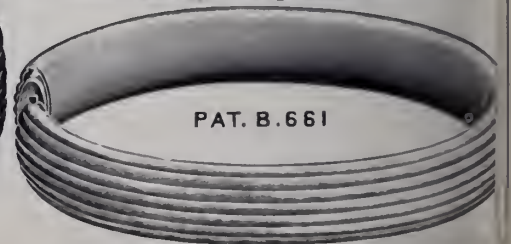

PAT. B. 661

The Best Selling "Thread" Pattern in the Trade



The SMITH "PILGRIM"

There never has been a more artistic and lasting design than the Smith "Pilgrim." It is characterized by simple elegance, refinement and dignity of design, and grateful absence of over-ornamentation. The Smith "Pilgrim" pattern will remain permanently in demand. Include "Pilgrim" in your stock. It is without question the best selling "thread" pattern in the trade to-day. Made in all the fancy pieces.

FRANK W. SMITH CO. MANUFACTURERS OF STERLING SILVERWARE Gardner, Mass.



TRADE MARK

SOME
TELLING
LINES



FOR
EVERY
JEWELER

HERE'S A CHARM in the unique. This virtue exists to a marked degree in the lines enumerated below. They represent the foremost importations of their class—the unique and unusual. Designs being inspired by the old masters, each piece is a study. Every jeweler should carry examples. Representatives always in the field. See the Lines.

SASH PINS—VEIL PINS—HAT PINS—BUCKLES—BROOCHES
NECKLACES—CHAINS—COMBS—JET GOODS

D. Lisner & Co. Creating Importers of *Jewelry Novelties*
One-Forty Fifth Avenue, cor. 19th St., NEW YORK



EASTER is the time of awakening and it brings with it a revival of the jewelry business. Many articles are called for, appropriate to the time and season, and the jeweler should be properly supplied. We have full lines of suitable goods: Crosses, Cuff Pins, Veil Pins, Locketts and Chains, also Fobs and Scarfpins, etc.; in fact, everything that may be desired in this line. They are all "Sellers," and we should be pleased to send memo. package upon request.

"Sellers
of
Sellers"

HENRY FREUND & BRO.

Diamonds
Watches
Jewelry

71 Nassau St., NEW YORK

Our Trade-Mark  "The Rose," stands for quality and excellence

...Announcement...



MARGUERITE

MR. RETAILER:

We are now ready to deliver through THE JOBBERS a new line of 14k. Gold 12s., O. F. plain bascine THIN MODEL cases, in LIGHT WEIGHT.

The production will be limited

BECAUSE

we cannot AFFORD to manufacture cases at this price under normal trade conditions.

Write for samples on Memo. from your JOBBER. Then TELEGRAPH your order.

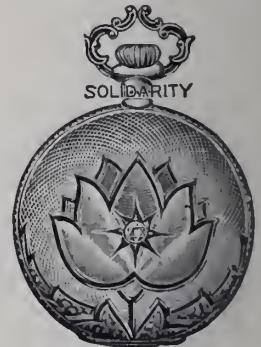

MARGUERITE

Solidarity Watch Case Company

Established 1885

54 Maiden Lane, New York

General Selling Agents:

JOHN W. SHERWOOD

::

::

FRANK E. HARMER

The KREMENTZ MATCH BOX

made expressly for paper matches, in 14-Kt. Gold and Sterling Silver, with the following finishes:
Roman, polished, engraved, engine turned and the Krementz gun metal finish.

Open



Side View
Closed



Order No.
in 14-Kt. Gold
2117

Front View
Closed



Order No.
in
Sterling
Silver
2043

The side and front views show its compactness. It opens and closes easily and fits the vest pocket, taking very little space.

KREMENTZ & CO.

Manufacturers of

Fine Gold and Enamel Diamond Jewelry in 14-Kt. Only

MADE EXCLUSIVELY FOR FINE RETAIL JEWELRY TRADE

BRANCH

San Francisco Office
722 Shreve Bldg.

Factory and Main Office
NEWARK, N. J.

BRANCH

New York Office
1 Maiden Lane

ELEMENTS OF STRENGTH AND FORM

TRADE



MARK

INCONSPICUOUS though it is the Collar Button means a lot of comfort—or discomfort. It depends on the make, the strength, the form. Durand Collar Buttons are smooth and shapely—therefore comfortable. Free from mechanism—therefore durable.

PRICES: \$1.15 to \$4.00

TRADE



MARK

DURAND & CO.

49-51 FRANKLIN STREET
NEWARK, N. J.



OSMUN-PARKER MFG. CO.

MAKERS OF

Fine Pearl and Diamond Goods

338 Mulberry Street

NEWARK, N. J.

ENOS RICHARDSON & Co.

MANUFACTURERS OF

14-K GOLD JEWELRY



- HANDY PINS
- SAFETY PINS
- BROOCHES
- FLAT LINKS
- DUMB-BELL LINKS
- FOBS
- TIE CLASPS
- VEIL PINS
- HAT PINS
- SCARF PINS
- BARRETTES
- BELT PINS
- 10-K AND 14-K NECK CHAINS AND GUARD CHAINS
- PLAIN AND JEWELLED LORGNETTE CHAINS

23 MAIDEN LANE, NEW YORK



The R. S. Cigar Cutter

In Sterling Silver, Plain and Engraved; and 14 k. Gold, Plain and Engraved, also Set with Diamonds.

A Novelty

Unlike all other cigar cutters, this one lies flat in the pocket—does not get out of order.

A Good Article



We Push It

Our advertising makes the customer want it; his friend sees it and he wants it. An endless chain of customers.

A Good Seller

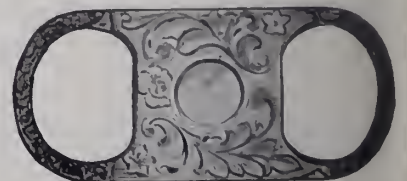

Trade supplied by

Enos Richardson & Co

23 Maiden Lane, New York.

G. R. HOWE
W. T. CARTER
W. T. GOUGH

ESTABLISHED 1841 BY A. CARTER

F. R. HORTON
F. W. STANBROUGH
H. L. FARROW

CARTER, HOWE & CO.

MANUFACTURERS OF

GOLD JEWELRY

ARTISTIC—SALABLE—RELIABLE

Most Comprehensive Line Offered

9-11-13 Maiden Lane, New York

Factory, Newark, New Jersey



Notice

Because

A person happens to dress in black, there is no reason why they should not enjoy wearing the very latest fashions.

Consequently we make all the latest fads and fancies in Mourning Jewelry, as well as

as a complete line of regular goods in Black Enamel.



TRADE-MARK

H. J. Hedges & Co.

Makers of 14 K. Jewelry

14 John Street

New York

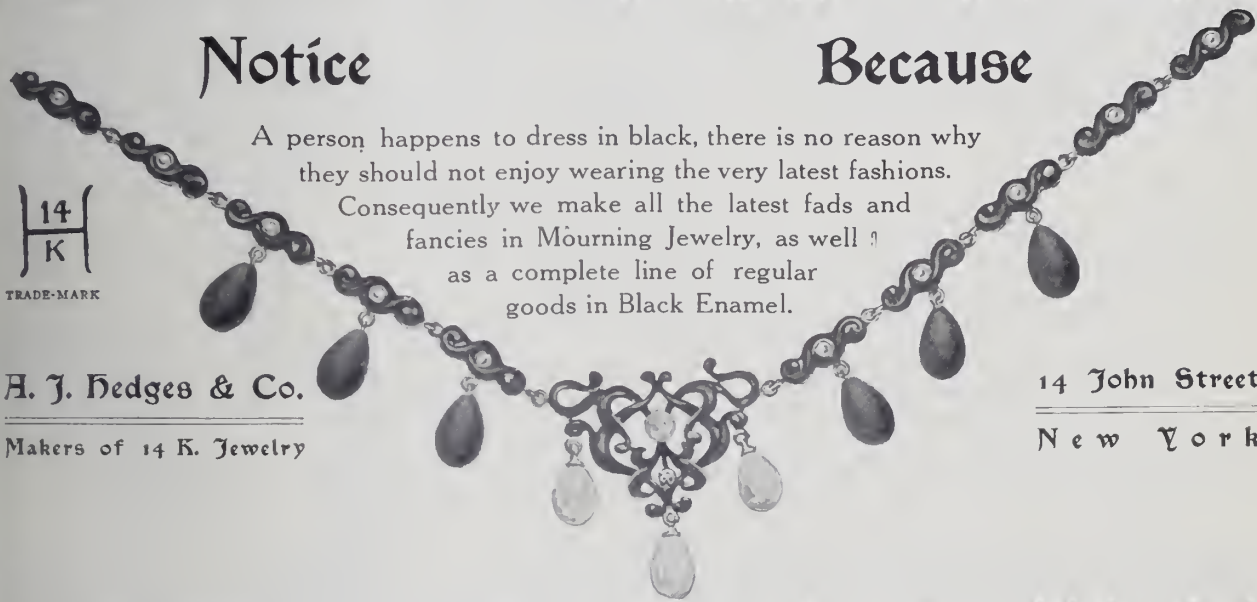

New Cigar Cutter

LOOKS AND WORKS LIKE A CHARM

This is the only practical cigar cutter that is a piece of jewelry for fob or chain. Can be set with diamonds and will admit of full size monogram engraving.

Patented and manufactured in 14K Gold by

Kollmar, Rauch & Co.

306 Market Street, Newark, N. J.

Sleeve Buttons
Fobs
Barrettes



Brooches
Scarf Pins
Handy Pins

PATENT POST

STRONG AND SUBSTANTIAL

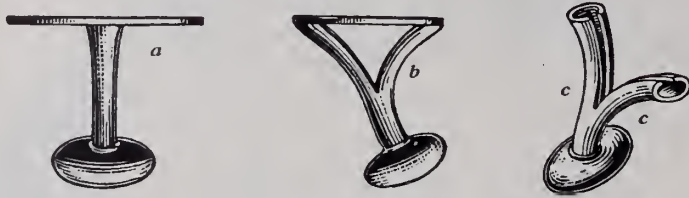

ILLUSTRATIONS ABOVE SHOW:

- A—Width of shoe to strengthen top of button.
 B—Shoulder on split which strengthens post.
 C—Double solder line on post to make it impossible for bean to come off.

We make the largest, most varied line of Cuff Buttons shown to the retail trade, also Locketts, Scarf Pins, Rings, Brooches, Crosses, Fobs, Neck Chains, Lorgnette Chains, etc., etc.

The **KELLER JEWELRY MFG. CO.**
 64 Nassau Street, New York

Factory: Newark, N. J.

"THE BRACELET HOUSE"

GOLD BRACELETS of every kind
 For WOMAN, MISS OR BABY

KENT & WOODLAND
 16 John Street, New York

Factory: Newark, N. J. San Francisco: Julius A. Young

TRADE



MARK

Geo. O. Street & Sons

35 Maiden Lane, New York

Established 1837

RINGS

SLEEVE-LINKS

SCARF-PINS

Fobs AND SEALS

THE BEST

SOLID GOLD CHAINS

THE CHEAPEST

They stand the test of time and have done so for 56 years.

Supreme in
**QUALITY
 DESIGN
 FINISH
 WORKMANSHIP**



We Sell Direct. We Have No Salesmen. Eliminating all unnecessary expenses in making and selling enables us to sell at the lowest possible price. Send for catalogue.

Trade  Mark

1850 1907

ALOIS KOHN & CO.

16-18 Maiden Lane, New York
 Makers of **Gold Chains** of every kind

The Bowden Rings

ARE COMPLETE IN VARIETY, CORRECT IN QUALITY AND PERFECT IN FINISH. WE MAKE EVERY VARIETY OF FINGER RINGS.

J. B. BOWDEN & CO.,

1 Maiden Lane,

NEW YORK.

THEBERATH & CO., Inc.

Manufacturers of unusual, exclusive and salable designs in 14k. gold

**Brooches, Festoons, Handy Pins,
Barrettes, Pendants, Veil Pins,**

in beautiful plain patterns, or set with precious and semi-precious stones.

KENT & WOODLAND, SELLING AGENTS

12 John Street,

NEW YORK CITY

The "Bryant" Rings.

WE have made the **Bryant Rings** for 50 years, and know how to make first class goods. The stone setting—which every retailer knows is a very important part of the work—we give special attention to. The **Bryant Rings** will help your reputation as a first class Jeweler.



TRADE-MARK

M. B. BRYANT & CO.,

No. 7 MAIDEN LANE,
NEW YORK.

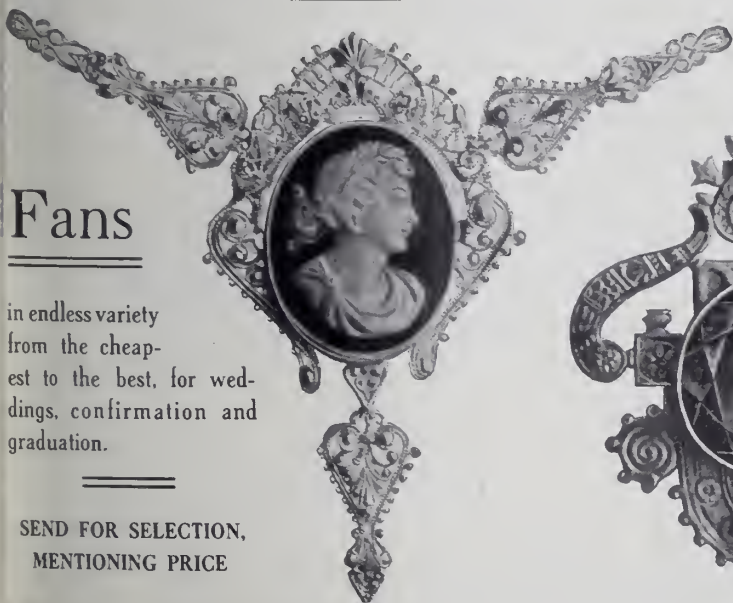

Fans

in endless variety from the cheapest to the best, for weddings, confirmation and graduation.

SEND FOR SELECTION,
MENTIONING PRICE

Novelties for Easter



in Necklaces, Buckles, Belt Pins, Brooches, Hat Pins, Collars, in sterling silver and gold plated, set with semi-precious and imitation stones: lapis, coral, amethyst, topaz, etc. Also an extensive line of Cameo Jewelry.

Pearl Drop Earrings

LEWY & COHEN
IMPORTERS

530 Broadway Cor. Spring St.
NEW YORK

I. N. LEVINSON, President

ESTABLISHED 1865

H. S. MORRIS, Sec. and Treas.

S. COTTLE COMPANY

Makers of High-Grade Gold, Silver, Gun Metal Novelties

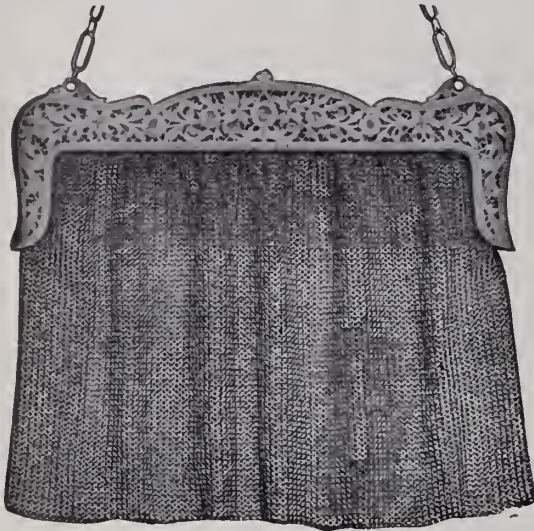

- Mesh Bags
- Buckles
- Card Cases
- Chatelaines
- Vanity Cases
- Sash Pins
- Purses
- Hat Pins

S. COTTLE CO.

31 EAST 17th STREET
NEW YORK

PARIS, 28 Rue D'Hauteville

Easter Lily Hat Pin



THIS is one of the most felicitous creations ever placed at the disposal of the trade.

Made in the size shown above, as well as smaller. Also in cluster form.

Baroque Pearl center. Some with diamond "dew drop."

Scarf Pins in same form.

Prices moderate



Day, Clark & Co.

Makers of 14-Kt. Jewelry

23 Maiden Lane
NEW YORK

ACTUAL
SIZE.



SEED-PEARL NECKLACES IN ALL SIZES.

OSMERS-DOUGHERTY CO.

MANUFACTURING JEWELERS

291-293 SEVENTH AVE., NEW YORK

Bet. 26th and 27th Sts. Telephone, 913 Madison.

DEALERS IN

BAROQUES, PEARLS and
FANCY STONES



DESIGNING

AND
SPECIAL ORDER WORK

SKILFUL REPAIRING

We have added a Repair Department to our factory, under the supervision of a highly competent man. Repairing of HEIRLOOMS and ANTIQUE Jewelry will be our specialty. We solicit only high class repair work requiring the most careful attention and skilful workmanship.

SCHULTZ & CO. INC.

Factory and Office
91 Oliver Street, NEWARK, N. J.



New York Salesroom
12-14 JOHN STREET

MAKERS OF BUSINESS BUILDERS

After July 1st, 1908, this Company will change its name to

LAYMAN & STRAUS CO.

PERCY M. LAYMAN

SYDNEY C. STRAUS

TRADE



MARK

A FEW OF OUR 3,500 DIFFERENT STYLES AND NUMBERS

TRADE



MARK



ABEL BROS. & COMPANY

ABEL BUILDING

64-66 John Street

107-109 William Street

NEW YORK

BRANCHES — LONDON PARIS IDAR OBERSTEIN GABLONZ AMSTERDAM ANTWERP

TRADE



MARK

TRADE



MARK

“If It Is Chopard’s Idea, It’s Ideal”

COLLARS and NECKLACES

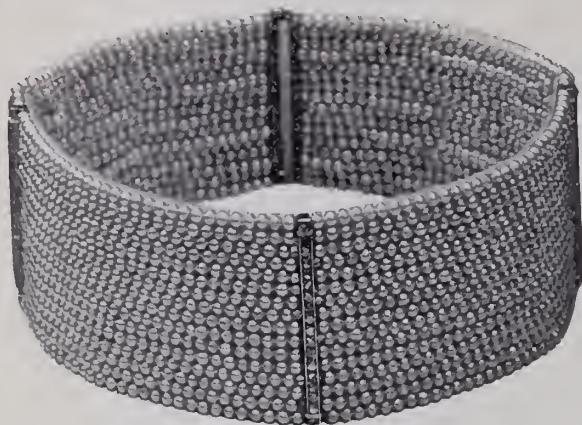

PEARL COLLARS: every width, every quality in stock or mounted to order.

JET COLLARS: fancy mounted Jet or Jet Bead Collars, both dull and bright in every width and length in stock.

NECKLACES: Pearl; Jet, dull and bright; and greatest variety of newest models in fancy novelty Necklaces and La Vallieres.

REMEMBER OUR SPECIAL DEPARTMENT created for you. For Restringing and Mounting Pearls, Pearl Collars, as well as Jet and other Bead Collars at Moderate Rates.

Selection Packages sent upon request to all reliable dealers

CHOPARD FRÈRES CO.

Factory, 35 Rue des Trois Bornes, PARIS, FRANCE

56 Maiden Lane, NEW YORK, N. Y.



Roller Chain

OUR SPECIALTY

Do not forget that we still continue to show the best line of these goods on the market, in Fobs, Bracelets and Neck Chains. These wear longer, give better satisfaction than any metal fob made, and our designs are up-to-date. Also our line of chains of all kinds find a ready market among the best trade, both in 1-10 and a medium wearing grade.

We also make a nice line of Brooches, Hatpins, Scarfpins, Barrettes, etc., that should demand your attention.

Ask your jobber, and if unable to obtain them from him, advise us who he is, and we will make arrangements for you to get them.

B. S. FREEMAN CO.

ATTLEBORO FALLS, MASS.

Chicago Office, J. T. Edwards, 103 State St., Chicago, Ill.

DIAMOND MOUNTINGS

of any description in gold and platina

Order Work a Specialty

HENRY BASCHKOPF

47-49 Maiden Lane

New York, N. Y.

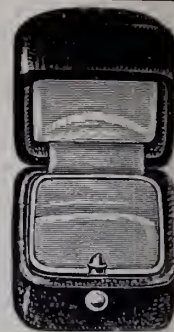

Fancy Platforms and Blocks for Window Display.

Trays, for Show Cases and Travelers' Use, of every description.

Jewelry Boxes in many qualities and styles.

Boxes for silverware. Manicure and Toilet Sets.

Silverware Chests in any combination.

Flannel Rolls and Bags for Silverware.

We Re-cover Window Platforms and Trays.

PAPER BOXES.

Tags, Cards, Cotton, Findings, Etc.

Estimates and Samples Cheerfully Furnished

WOLFSHEIM & SACHS

Office and Salesroom:

35 Maiden Lane,

(Lorsch Building)

NEW YORK

Factory: 10 Gold Street, N. Y.

A NEW CREATION IN

Hat Pins

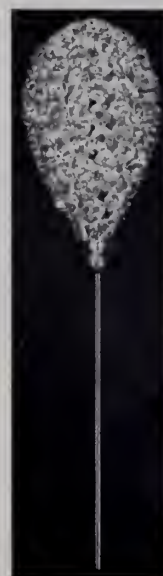

Made of the finest brilliant Rhinestones. Can be sold for less than the imported ones. They come in pear, ball and half ball, octagon and heart shapes, and can be retailed from

50c.

to

\$5.00

at a handsome profit. Ask your jobber or write us for sample assortment.

ACME COMB AND NOVELTY CO.

Manufacturers

Factory and Office

147 Spring St., New York

Salesroom: 194 Broadway



SOLID GOLD COMBS

From \$1.50 Upward

A Snappy New Spring Line

in Plain and Engraved Bands, also

New Effects in Pierced Tops

14k.—Everything in Gold Jewelry—10k. Brooches, Barrettes, Buckles, Bracelets, Pendants, Festoons, Emblems, Hat Pins, Fobs, Scarfs, etc.



2 Maiden Lane, New York

THE GREAT AMERICAN JEWELRY CATALOG

Is a publication of real practical value; it truthfully illustrates those lines of merchandise; best adapted to the needs of the *Jewelry Trade*; it's reliability is unquestionable.

SAFETY

With implicit confidence you can use it when ordering goods; it insures you against deception; remember, for every dollar's worth of merchandise you buy you are obtaining positive, intrinsic value.

Write for this catalog; it means much to you.

THE OSKAMP-NOLTING CO.

Mammoth Wholesale Jewelers

411-413-415-417 Elm St., CINCINNATI, OHIO



UNIQUE GEMS

SEMI-PRECIOUS CEYLON, URAL and NATIVE

GEMS My Specialty

Prices the Lowest. Sample Papers sent on Request to Reliable Jewelers and Manufacturers.

Louis J. Deacon, Atlantic City, N. J.



CAMEOS

In these times the jobber, in order to stimulate his business, must create a run on some special article. And just now, why not the Cameo? It is sure to be a good leader and is being extensively advertised by a number of manufacturers.

We are mounting stone, shell and coral Cameos in scarf pins and brooches. A good assortment of Cameos should be found in every line this season. Let us send you a few samples on memorandum.

THIS TRADE-MARK on every piece of jewelry that leaves our factory. A medium-priced line of 10K. jewelry that has stood the test. Will say no more, but let us show you and be convinced yourself.

W. E. RICHARDS CO.

Manufacturers for the Jobbing Trade
ATTLEBORO, MASS.

New York Office: 12-14 John Street Samples only

Send for further information regarding our extensive line.

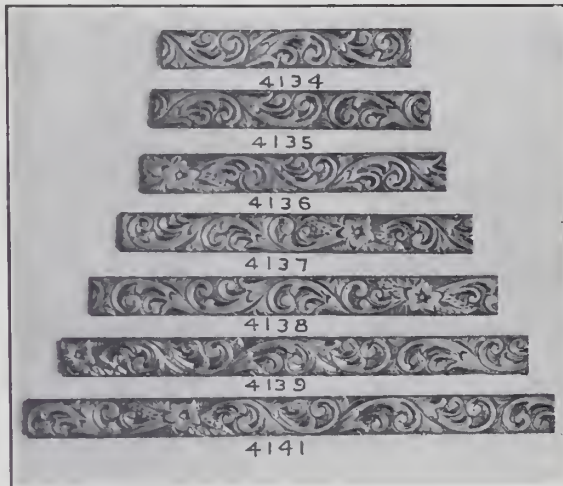

Seamless Gold Plated Pins

FOR EVERY USE

Variety of Patterns in Plain and Engraved, in lengths one to four inches : : : : :

GUARANTEED GOLD FRONT, BACK AND SIDES

SEND FOR SELECTION

Maintien Bros. & Elliot, Makers of Jewelry for the Jobbing Trade

NO. ATTLEBORO, MASS.

New York Office, 9-11 Maiden Lane

Send for the Latest Styles in
MONOGRAMS AND INITIALS

as manufactured by

THOMAS J. DUNN CO.

101 Chambers St., New York
Makers of exclusive styles in

MONOGRAM FOBS

in Gold, Sterling and Rolled Gold Plate. Our 1908 Ladies' Belt Buckles are most original and artistic.

Specialties in the Monogram and Initial line.

Send for Illustrated Sheets.

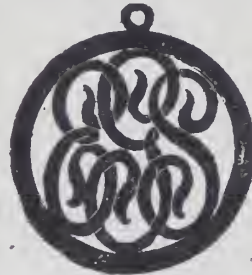

TRADE **SNOW & WESTCOTT CO.**

21 MAIDEN LANE, NEW YORK



JAMES P. SNOW

CHAS. E. WESTCOTT

Makers of Fine Gold Jewelry

ESTABLISHED 1834

LOCKETS ONLY

Registered



U. S. Pat. Office



Pat. Applied for
NUMBER
8482

Latest Design Appropriate for Easter

WIGHTMAN & HOUGH CO.

NEW YORK OFFICE
3 Maiden Lane

Main Office and Factory } 7 Beverly St.
PROVIDENCE, R. I.

Important Notice

The jewelry trade is hereby notified that the following manufacturing jewelers have been granted licenses under my pending patents to manufacture and sell the "Fashion" Collar Pins:



KREMENTZ & CO.
CARTER, HOWE & CO.
BIPPART, GRISCOM & OSBORN
A. J. HEDGES & CO.
ECKFELDT & ACKLEY
J. T. MAURAN MFG. CO.
WOLCOTT MFG. CO.
ARCH CROWN MFG. CO.
SCHRADER-WITTSTEIN CO.
THEO. W. FOSTER & BRO. CO.



The trade is informed that I shall protect our rights under my pending patents to the full extent of the law, and having confidence in the fairness of the trade in general, I believe that I may expect its co-operation by refusal to purchase should other manufacturers than those above mentioned offer "Fashion" Collar Pins in imitation of mine.

Thanking the trade in advance for its consideration, I beg to remain, very respectfully,

CHARLES T. WITTSTEIN

ARCH CROWN MANUFACTURING CO., Camp & Orchard Sts., Newark, N. J.



S. F. Myers & Co.

WHOLESALE JEWELERS
47-49 Maiden Lane
New York

A new era of National prosperity—greater than ever known—is before us. Our share is secure.

For the trade only—our new, big catalogue, with 100,000 items, sent free.

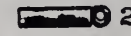
GARREAU & GRISER
68 & 70 Nassau St., New York
LAPIDARIES. PRECIOUS STONES
GEMS in Unique Cuttings

-  1. Snap complete.
-  2. Outside of snap.
-  3. Inside of snap.

The E. P. H. Patent NON-PULL-OUT Neck Chain Snap

is a patented snap that insures the wearer against loss of

CHAIN or CHARM

for it positively will not pull out

Made in 10 and 14 Karat Gold and in Gold Filled.

Can be had of the following Wholesale Selling Agents:

Messrs. W. Green & Co.,
81 Nassau St., New York

M. Sickles & Sons, Philadelphia
E. A. Cowan & Co., Boston
E. & J. Swigart, Cincinnati
Swartchild & Co., Chicago
Nordman Brothers, San Francisco
Leonard Krower, New Orleans
A. Walker Co., Providence, R. I.
Bauman-Massa Jewelry Co., St. Louis
H. S. Meiskey Co., Lancaster, Pa.
The Edw. Lehman Jewelry Co., Denver, Col.

PRICES.

14 Karat—Small, \$7 per doz. net
Large, \$7.50 per doz. net
10 Karat—Small, \$6 per doz. net
Large, \$6.50 per doz. net
Gold Filled—Small, \$2 per doz. net
Large, \$2.25 per doz. net

Pierceless Ear Screws

We are making a complete line of these popular goods. Samples upon request.

Also a new line of

- Brooches
- Scarf Pins
- Baby Pins
- Links
- Studs
- Crosses
- Ear Rings
- Rings
- Neck Chains

We have manufactured Gold jewelry for over fifty years and our goods have stood the test of time.

DON'T NEGLECT TO
SEE OUR LINE.

Wm. C. Greene Co.

Established 1849 Incorporated 1906

MANUFACTURERS OF
GOLD JEWELRY

101 Sabin Street,

Providence, R.I.



A MILLION RINGS ARE NOW worn that are loose on the finger and need Wells Perfect Ring Adjusters to hold them in place. Why not fit these and make a good profit and new customers.

Ask your Jobber for them Sold in 1 doz. assorted sizes in packages as follows: 10 K. Gold, \$3.75; Gold Filled, \$2.00; Metal, 85 cents.

CHESTER H. WELLS, Jeweler, Meshoppen, Pa.

THE CROHN PATENT SAFETY GUARD

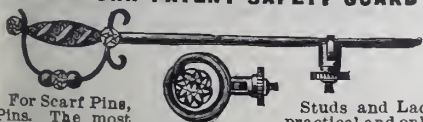

For Scarf Pins, Studs and Lace Pins. The most adjustable one invented. Price, \$1.50 per doz. For sale by all wholesale jewelers and material houses. Sample by mail, 25c.; in 10k. gold, \$1.00; 14k., \$1.25. M. CROHN Maker and Inventor, 48 and 50 Maiden Lane, N. Y.

Warning to the Trade

"HOLD-ON" CLUTCHES



We are the sole and exclusive licensees for use in jewelry under Patent No. 700,412, dated May 20, 1902, granted to Max H. Fischer for Clutches. This is a broad, comprehensive patent for clutches under which patent we have manufactured and sold our "HOLD-ON" clutches for scarf pins, etc., for many years past.

We have brought suit in the United States Circuit Court for the Southern District of New York against various concerns and persons for patent infringement, unfair trade and imitation of our clutches and for FORTY THOUSAND DOLLARS (\$40,000) damages.

We have also brought suit in the same court for the infringement of said patent against another concern having lately placed another similar device on the market, and we will also bring suit against all others who make, sell or offer for sale any clutch infringing upon our patents covering the manufacture of the Hold-On Clutch.

We are informed by our counsel that the claim of these parties that their clutches are made under patents does not excuse the infringement, as they are ALL LATER than the Fischer invention.

All dealers are hereby warned that the making, selling, using or otherwise handling any of the above devices except through us, will be deemed an infringement of our rights, for which suit for infringement and damages will be immediately brought, and WORTHLESS GUARANTEES will not avail dealers who handle such goods.

It is our intention to vigorously prosecute all infringements of the patent and trade rights and to protect our rights by every means in our power.

Hold-On Clutch Company

C. P. GOLDSMITH & CO., Proprietors



One of Many

VERIBEST

Label Inside

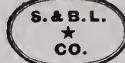

Lifetime Guarantee

LOCKETS

Sold by

VERIBEST JOBBER'S

EVERYWHERE

The S. & B. L. ★ Co. Mark
is not a Label—
It is a Guarantee
for Lifetime Satisfaction
and the most value for
your money.

S. & B. LEDERER CO.

QUALITY WEARS GOODASGOLD

New York City: 9-11-13 Maiden Lane

Providence, R. I.: 100 Stewart St.

Chicago, Ill.: 131 Wabash Ave.

"HOLD-ON" CLUTCH



FOR SCARF PINS AND BROOCHES



14K. GOLD PLATE
SUPERIOR TO ALL OTHERS

PRICE 50 CENTS

ADVANTAGES:

1. *It Holds*—The harder you pull, the tighter it holds.
2. *To Release*—Raise the clutch and pull the ball.
3. *All One Piece*—No parts to lose.

Pat. May 20, '02
To Release
Pull the Ball

Pat. May 20, '02
Attached
to Scarf Pin

HOLD-ON CLUTCH CO. 33 GOLD STREET NEW YORK

P & B FOBS

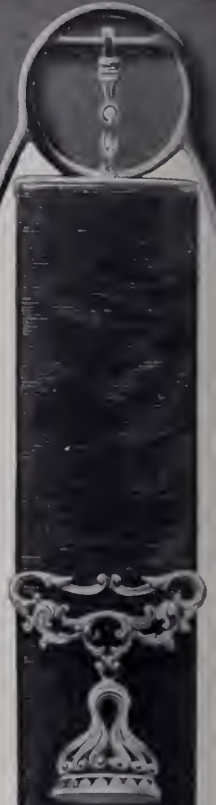

ALL STYLES AND PRICES
BOTH RIBBON AND ALL GOLD

ASK YOUR JOBBER FOR THE P & B LIST
Cuff Buttons Crosses Tie Clasps
Brooches Fobs Baby Pins
Beadnecks Locketts Bracelets

**POTTER &
BUFFINTON CO.**
PROVIDENCE, R. I.

Orders Prove Our Goods Sell

We make for the Jobbing Trade the following lines of Solid Gold Jewelry:

Rings, Scarf Pins, Studs, Brooches, Charms, Baby Pins, Handy Pins, Chain Sets, Link Buttons, Hair Barrettes, Crosses, Ear Screws, Pierceless Drops, Cameos in all styles, etc.



Insist upon seeing the designs of Gold Jewelry made by the

E. L. Spencer Company

95 CHESTNUT STREET
PROVIDENCE, R. I.

NEW YORK OFFICE
9-11-13 MAIDEN LANE

(SAMPLES ONLY)



While your business is somewhat dull you will find it to your advantage to look up the local order for

CLASS PINS

Write us for Catalogue J 30, and Samples

THE CHAS. M. ROBBINS CO.

MANUFACTURING JEWELERS AND ENAMELERS
ATTLEBORO, MASSACHUSETTS



MONOGRAM BELT BUCKLES

Made in 14Kt. Gold, Sterling Silver and Gold Plate.

All kinds of PATENT and FANCY LEATHER BELTS, including KID and PIGSKIN.

WALDRON & CARROLL, MAKERS, 34 WARREN ST., NEW YORK

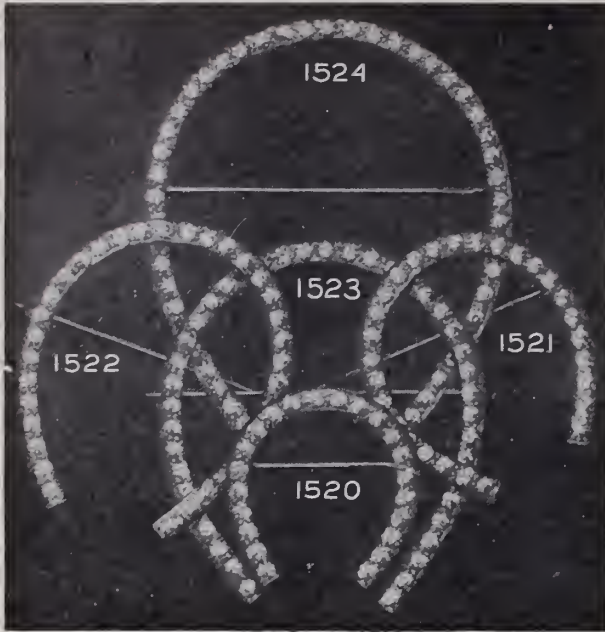

Sterling Silver Horseshoes

14 Karat Gold Finish set with Whitestones or Pearls

Write for Selection Package with Prices

Wachenheimer Bros. 36 GARNET STREET PROVIDENCE, R. I.

Perennially Popular

THE best evidence of the popularity of our various lines is the increasing demand for them and our consequent growth. Our jewelry is unexcelled in every quality that contributes to serviceability and appearance. The designs are artistic enough to court that investigation which results in sales.



Ask to see our line of

**CHAINS
CHAIN PENDANTS
CROSSES
AND BRACELETS**

The **Kenilworth Bracelet**

particularly, the strongest on the market.



**DORAN,
BAGNALL & CO.**

North Attleboro, Mass.

OFFICES

New York: 194 Broadway.
Chicago: 42 E. Madison St.
San Francisco: 91 Drumm St.

EVERYTHING IN LOCKETS AND CHAINS.

THE BASSETT JEWELRY CO.,

PROVIDENCE, R. I.

"GOLD MEDAL"

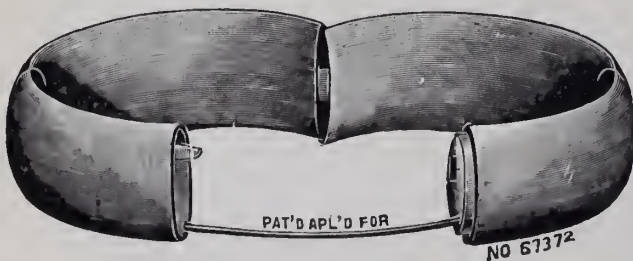

"Geraldine Farrar" "SECURON" Hinge Bracelet

Try Them

If for the first time—

To buy them once means to repeat.

Guarantee "Pr. St. Co." Mark Inside

PROVIDENCE STOCK CO.

9-11-13 Maiden Lane
NEW YORK CITY

100 Stewart Street
PROVIDENCE, R. I.

131 Wabash Avenue
CHICAGO, ILL.

10K. GOLD BRACELETS

New and Original Designs in—

**BANGLE, JOINT
AND
CATCH SIZES**

Scarf Pins, Ladies' Rings, Earrings and Handy Pins

In a great variety of designs

TRADE MARK

THE **Edwin Lowe & Co., Inc**
F.W. BODWELL, Pres. & Gen. Mgr

116 Chestnut St., PROVIDENCE, R. I.
New York Representative: Western Representative:
E.T. Wilson, 180 Bway. S. H. Brower

GEMS AND PRECIOUS STONES

Cloth, Postpaid, \$1.00.

Published by The Jeweler's Circular Publishing Co.

11 JOHN STREET

NEW YORK

COMPLETE YOUR STOCK WITH RIGHT GOODS

GOLD RINGS

Gold Scarf Pins Gold Brooches

A Handsome Line of Seamless Wire GOLD FILLED RINGS

All ready for prompt delivery to the Jobber

OSTBY & BARTON CO.
PROVIDENCE, RHODE ISLAND

New York Office
9-13 MAIDEN LANE

Chicago Office
103 STATE STREET



CORAL HAT PINS

¶ The spring season and Eastertide are here, and as usual there will be a big demand for hat pins. ¶ Coral jewelry is popular in the extreme, and our line of Coral Hat Pins, showing hundreds of new designs, is one of the finest showings on exhibition at present. The prices range from \$6.00 to \$24.00 per dozen.

SELECTION PACKAGES SENT ON REQUEST

M. GUGENHEIM,
IMPORTER

Brooches, Festoon Chains, Combs, Hat Pins, Collars, Jet Goods, Mesh Bags, in German Silver, Gilt Metal and Sterling
NEW YORK OFFICE: 33 Union Square, Decker Building PARIS: 32 Faubourg Poissoniere

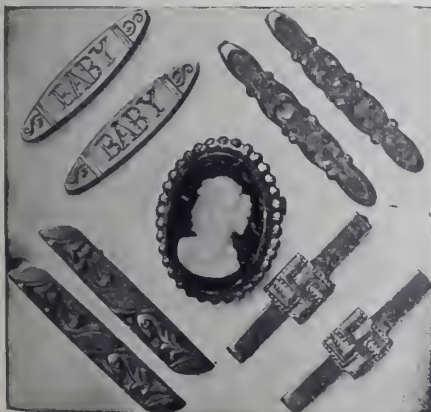

Veil, Cuff and Baby Pins

An immense line. Many new designs supplementing our staple patterns—all of acknowledged beauty and easily sold.

Cameos A revival of an old-style decoration too good to remain in oblivion.
Shell, Coral and others, mounted as Brooches, Stick Pins, etc.

Swastika Buckles Bracelets Buttons
Charms Brooches Barrettes
Combs, Hat Pins, Scarf Pins, Leather Trimmings

MILLER, FULLER & WHITING CO.
Manufacturing Jewelers
New York Office, 9-11 Maiden Lane NORTH ATTLEBORO, MASS.
WE SELL TO THE JOBBING TRADE ONLY





NEW YORK OFFICE
No. 7 Maiden Lane

CHICAGO OFFICE
1203 Heyworth Building

O. M. DRAPER CHAINS

ALL KINDS OF VEST CHAINS
PRINCESS, NECK AND GUARD CHAINS

We do not make as much noise as some of our friends but we are "there with the goods" and the *Jobbing Trade* handling our product for the last half century, know that our QUALITIES are genuine and can be depended upon, that our FINISH is unparalleled and that our prices are consistent.

If you do not handle O. M. DRAPER GOODS, we both lose.
We sell only to the Jobbing Trade.

Estate of O. M. DRAPER
Factory, No. Attleboro, Mass.

NEW YORK OFFICE
37 Maiden Lane

SAN FRANCISCO
506 Chronicle Building



The Gillette Safety Razor Set consists of a triple silver-plated holder and twelve double edged, thin, flexible, wafer-like blades (24 keen edges), packed in a velvet lined leather case. Price, \$5.00. Also made in Combination Sets in a variety of styles with toilet accessories retailing from \$6.50 to \$50.00 each.

Would You Have the Present Year Bring You Increased Patronage, Profit and Prosperity?

Do you realize that nearly every hour in the day some man is converted to the easier, quicker and more economical way of shaving himself with the

Gillette Safety Razor?

Our persistent and vigorous advertising in the leading publications of this country discloses — *and will continue to disclose* — beyond all question of doubt, the superiority of the "Gillette." It advocates the advantages of self-shaving and guides the man to your store with a five dollar bill to exchange for the best shaving device in this world.

You can readily see the wisdom of having the "Gillette" ready when he calls. The Standard Gillette Set retails at \$5.00 everywhere. Combination Sets from \$6.50 to \$50.00. Keep a good supply in stock. Write to-day for valuable selling information and prices.

GILLETTE SALES CO., 904 Times Bldg., New York City



Scarf Pin 891
Old English
Set as ordered

Scarf Pin
842—Rose
or Green
Set as
ordered

Neck Chain 296
Old English Chain
Roman Scrolls
16" long
Stones set as ordered
Baroque Pearl
Pendant

Link Button
877—Rose, Ruby
and Brilliants
878—O.E., Ruby
and Brilliants

Link Button
872—O.E., Stones set
as ordered



Charm 2982
Rose, Ruby Stones

Easter Suggestions

We have this season many choice designs in Fine Gold Filled Jewelry, suitable for Easter gifts, among which are Neck Chains and Pendants, Locketts and Charms, Link Buttons and Bracelets, as well as Brooch, Veil, Scarf and Hat Pins. Our Gold Filled Goods meet the most critical test for high standing.

We mention our Sterling Silver Toilet, Manicure and Table Goods as appropriate Wedding Gifts.

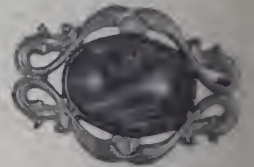

Brooch Pin
3864—Old English, Japanese
Jade Stone



Locket
3013—Rose, No Stones
3016—Rose, Red Eyes,
White Mouth



Scarf Pin
884—O.E.
Set as
ordered



Belt Buckle
3540²—Rose, Ruby Eyes, Stone in Mouth set as ordered, Pin Stem
3540 —Rose, Ruby Eyes, Stone in Mouth set as ordered, Clasp



Scarf Pin
886—O.E.
Set as
ordered



Charm
2984—Rose, Red Eyes,
White Mouth
2983—Rose, No Stone

Theodore W. Foster & Bro. Co.

Manufacturing Jewelers and Silversmiths

100 RICHMOND ST., PROVIDENCE, R. I.

NEW YORK: 13 Maiden Lane

CHICAGO: Heyworth Bldg.

CANADA: Kingston, Ontario

THE JEWELERS' CIRCULAR

WITH WHICH ARE CONSOLIDATED
 THE HOROLOGICAL REVIEW
 THE JEWELERS' WEEKLY THE JEWELERS' REVIEW

VOL. LVI. WEDNESDAY, APRIL 8, 1908. No. 10.

A Magnificent Christening Set.

BETWEEN religion and art, from the earliest times, the closest relations have existed. In the forms art has furnished, man has, from the beginning, embodied his conceptions of the Deity and as imparted to the shapes of his divine service a dignified character, with the aid of art. Religion has always been the leading promoter of every artistic effort. The lately tree of art would be robbed of its nest branches and its fairest fruits, if we deprived it of religious art. In the fields of the gold and silver-smiths' arts, the choicest and best that has been created has been produced in the

quisite creations are being constantly produced. Illustrated on the front page of this issue is a beautiful baptismal basin or christening font, made for the Court Church of St. Andreas at Düsseldorf. The pitcher and warming flasks shown on this page are included with it in the set. The christening font and pitchers, the latter serving for the warming of the christening water, are entirely in embossed silver, in Renaissance style, partly gilded. The center field of the basin is richly decorated with engraving and enamel. In the center, at the bottom of the basin, is an enamel picture, baptism; to the left of this the expulsion from Paradise; on the right the brazen serpent. The central enamel picture is surrounded by rich figure pictures, engraved and show: 1. The entry of Noah into the Ark. 2. The passage of the Red Sea. 3. Moses drawing water from the rock in the wilderness. 4. Christ baptized by John in the Jordan. The entire work is executed in the finest manner.

of meerschaum for this industry is becoming low, and the discovery of deposits of the mineral in New Mexico is therefore interesting.

Two deposits of meerschaum have been located in the upper Gila River Valley, one about 23 miles northeast of Silver City, the other at a mine about 12 miles northwest of Silver City.

Douglas B. Sterrett, of the United States Geological Survey, visited the mine in October, 1907, and has prepared a report on the deposit there which has just been published by the Survey as a part of an advance chapter of Bulletin No. 340, "Contributions to Economic Geology, 1907." The



WARMING FLASK.

Meerschaum in New Mexico.

FOR more than a century meerschaum has been extensively used in the manufacture of pipes and cigar-holders, the principal source of supply for the material being deposits in the plains of Asia Minor, about 120 miles southeast of Constantinople. These deposits are said to have been worked for other uses for more than a thousand years.

The German name meerschaum ("sea foam") is paralleled in French by *écume de mer*, which may be less beautifully translated "scum of the sea." The mineralogist will tell you it is sepiolite, a hydrous silicate of magnesia, but this designation will not diminish the smoker's enjoyment of his meerschaum pipe.

The ease with which meerschaum can be carved, its whiteness and the fine polish it takes with wax render it especially suitable for elaborate carving and artistic treatment in the manufacture of pipes. These pipes are prized for their rich cream-brown or brown color that the bowls assume after being smoked a while. This color is caused by the permeation through the meerschaum of the mixture of the nicotine from the tobacco with the wax used in polishing the pipe. As long as there is absorbed wax in the meerschaum the color of the pipe will grow darker, and with continued smoking will become nearly black. It is therefore necessary to "fix" the color of the pipe when the proper shade is reached. The method employed to accomplish this is in part a trade secret.

The manufacture of meerschaum into pipes is a thriving industry in parts of Germany and Russia, employing more than 3,000 workmen. It is said that the supply



CHRISTENING PITCHER.

deposit lies in the bottom and walls of the canyon of Bear Creek, occurring in veins, lenses, seams and balls in limestone in both nodular and massive form. The nodular meerschaum thus far tested contains iron stains and particles of grit and is inferior to the meerschaum of Asia Minor. The more compact, massive material may perhaps be found free from stains and of better quality.

Mr. Sterrett's report sketches briefly the geological relations of the deposits, describes the mode of occurrence of the meerschaum and presents the results of tests and analyses of the mineral.

The pamphlet containing the report may be had on application to the Director of the Geological Survey, Washington, D. C.

service of religion. The specimens of old and silver work of a profane or lay character, that remain to us from the middle ages, make up an infinitesimally small quantity, compared with the great volume of ecclesiastical articles. Even for subsequent centuries, a comparison will hardly prove unfavorable to the churchly objects. Certainly, we must consider that under the safe guardianship of the place of worship, much more could be preserved than under the vicissitudes of private ownership. The treasure chambers of numerous churches still conceal incalculable treasures in the shape of precious metal objects. But, if the past has been glorious, the present is not less so, and, in the domain of ecclesiastical gold and silver work, ex-



EVERY BUSINESS DAY

we receive broken shirt studs to be repaired, of some other manufacturer's make. Because the studs have a spring in them some jewelers think we are the makers. Nearly all of them are so poorly made that the manufacturer is ashamed to father his own offspring and does not put a Trade-Mark on them for identification.

To the contrary, the Larter Shirt Stud has stamped on the barrel of each our United States Registered Trade-Mark, which is our guarantee that there is absolutely no better shirt stud made, and that we cheerfully give a new one if an accident happens.

This applies to 18K. and 14K. gold, also 10K. gold and 14K. gold filled. These last two lines to be had from progressive jobbers.

Why not carry in your stock the largest and best line of shirt studs made?

LARTER & SONS

21-23 Maiden Lane, New York, N. Y.

TRADE-MARK



REGISTERED IN U. S. PATENT OFFICE

ELSIE BEE'S FASHIONS.

SPRING NOVELTIES NOTED IN A LADY'S RAMBLES
AMONG THE JEWELERS.

PERFUME boxes, containing three tiny bottles, are treated in transparent enamel with most pleasing results.

* * *

One of the most elaborate productions in the way of ecclesiastical objects to be presented as memorials for Easter is a chalice of silver-gilt body and gold bowl. In outlines it is most artistic, and the rose gold carving is beautifully set off by the cross of aquamarines at the base, the border of carbuncles at the outer edge and the circle of moonstone hearts near the rim of the cup.

* * *

Still another step has been taken in the art of enameling and the success attained proves American capabilities. The articles illustrating this advance are little trinket or bonbon boxes, exquisite and dainty, in transparent enamel. The patterns are first engraved on the silver, touched up with gold where the design demands, and then the fondant is placed over this, giving the glazed effect. The old English engraving employed to secure ribbed or moiré effect, and the colors—soft blues, lavenders, rich reds—show up charmingly through the transparency.

* * *

A novel portmonnaie does away with the clasp idea. The two outside silver sections in new outlines and handsomely engraved with ample extensions between, both at the top and at the bottom, are held together by the chain which passes through the two rings at either end of each section. The purse may thus be carried by a single or double chain, but there is no danger of its opening as the weight of the bag draws the chain taut and thus closes the purse tight and firmly. The arrangement of the accordion leather that forms the compartments is also an advantage as it gives room for handkerchief or other small articles.

* * *

One of the most striking novelties of the season is a silver portmonnaie that has just appeared. Launched by the same firm that introduced the bracelet bag, it is unique in every feature—entirely unlike anything that has ever been seen before. Instead of being flat, it is cylindrical in shape, about eight inches long and two and a half inches in diameter. It is of solid silver, saw-pierced and etched, the color moiré lining showing through the perforations formed by the piercing. The handle has a peculiar curve and it is attached to the purse by means of a large single link at either end, giving a longitudinal movement to the handle. The inside has the usual compartments, the two outside ones offering a large curved space to hold the usual contents of the hand bag. As to color when this bag or portmonnaie offers opportunity for the matching with gowns, white workmanship places it in the front rank of articles of the kind. It will make an appeal to the woman who is in search of the distinctly new and original, resembling more than anything else an abbreviated music box made of silver.

ELSIE BEE

Some Interesting Statistics as to the Gold and Silver Used in the Arts.

WASHINGTON, D. C., April 2.—Estimating that the total amount of gold coin used in the arts is \$3,500,000 and of silver coin \$100,000, the total industrial consumption for the year ending Dec. 30, 1906, was as follows:

	Gold.	Silver.
	Fine Ounces.	
Domestic bullion....	\$18,667,804	\$15,231,628
Foreign material....	10,452,037	2,734,187
United States coin..	3,500,000	77,344
Old material.....	6,506,922	3,810,105
Total	\$39,126,763	\$21,853,264

It may not be without interest to show what the growth of this consumption of gold and silver has been in the United States during the past 20 years or more, and the sources from which we draw our supplies. This will be divided into United States coin, domestic bullion, foreign bullion and coin, and old materials, as follows:

During the past fiscal year the value and composition of bars issued by the Government institution for use in the industrial arts included 1,019,394.699 fine ounces of gold domestic bullion at a total value of \$21,072,758.64 and 1,998,942.12 fine ounces of silver. Of gold in foreign bullion the amount issued was 503,521.986 fine ounces at \$10,402,521.68 and 1,708,476.98 fine ounces of silver. Of gold from foreign coin there was issued for this purpose 515.943 fine ounces at \$10,665.49 and 174,566.81 fine ounces of silver, \$204.81 of silver United States coin, and of gold bars manufactured from old material 231,711.574 fine ounces at \$4,789,903.31, and of silver 504,348.98 fine ounces. This made a total of 1,754,844.202 fine ounces of gold at \$36,275,849.15 and 4,386,539.70 fine ounces of silver.

The total value of fine gold bars furnished to the trade in exchange for gold coin and bullion during the past fiscal year at Phila-

delphia was for gold coin \$7,092,942.25, and at the New York assay office, \$49,830,260.36, or a total of \$56,923,202.61. Of this exchange for coin, \$25,170,899.79 were exported and \$31,752,302.28 was used in the industrial arts. The total value of fine gold bars furnished to the trade in exchange for gold bullion was, at Philadelphia \$265,997.19, and at New York \$4,257,549.69, or a total of \$4,523,546.88.

It is estimated by the Director of the Mint that the world's consumption of the precious metals in the arts in 1906 included 182,969 kilograms fine of gold, at a total value of \$121,601,200. This in ounces is equivalent to 5,882,458. Of silver, the estimated consumption was 2,649,956 kilograms, or 85,196,100 ounces, at a total value of \$57,668,388. In these estimates only new material was taken into account.

During the fiscal year the domestic deposits of jewelers' bars, old gold, plate, etc., at the various mints was as follows, in standard ounces:

Philadelphia	55,759,518	\$1,037,386.38
San Francisco.....	5,043,607	93,834.60
New Orleans.....	2,532,280	47,112.13
Denver	2,771,671	51,565.97
New York.....	237,719,920	4,202,696.25
Helena	140,748	2,618.54
Charlotte	157,368	2,927.75
St. Lou's.....	1,553,679	28,905.54
Seattle	702,729	13,074.03

Total

Total 306,381,520 \$5,700,121.19

The same with regard to silver is as follows:

Philadelphia	113,812.97	\$132,436.91
San Francisco.....	34,341.92	39,961.51
New Orleans.....	3,772.87	4,390.25
Denver	1,900.79	2,211.82
New York.....	523,340.62	608,978.18
Helena	32.04	37.28
Charlotte	56.60	65.83
St. Louis.....	397.32	462.33
Seattle	181.42	211.11

Total

Total 677,836.55 \$788,755.22

The profits on medals and proof coins manufactured by the mint during the past fiscal year was \$1,252.37, and the amount charged for the manufacture of medals \$6,756.86.

It has been estimated that during the calendar year of 1906 the production of gold in the United States was \$94,373,800, of which \$39,126,763 was consumed in the industrial arts.

During the fiscal year ending June 30, 1907, the Government purchased 11,999,866 ounces of silver bullion at an average of \$0.67727+ per ounce of 0.999 fine. This was purchased for the manufacture of subsidiary coins.

Among the purveyors of gold and silver bars for use in the industrial arts in the United States the United States Mint at Philadelphia and the United States Assay Office at New York hold the foremost places; consequently the larger portion of the material consumed in the arts is brought under Government notice and is a matter of public record.

During the calendar year of 1906 the value of domestic gold bullion manufactured in private refineries for use in the industrial arts was \$188,042, and that from

GOLD.

New material.

	U. S. coin.	Domestic bullion.	Foreign bullion and coin.	Total new material.	Old material.	Grand total.
1880.....	\$3,300,000	\$6,000,000	\$1,267,600	\$10,567,600	\$395,000	\$10,962,600
1881.....	2,700,000	7,000,000	1,547,800	11,247,800	522,900	11,770,700
1882.....	2,500,000	7,000,000	671,500	10,171,500	696,500	10,868,000
1883.....	4,875,000	7,840,000	194,500	12,909,500	1,549,300	14,458,800
1884.....	5,000,000	6,000,000	385,500	11,385,500	3,114,500	14,500,000
1885.....	3,500,000	6,736,927	178,913	10,415,840	1,408,902	11,824,742
1886.....	3,500,000	7,003,480	638,003	11,141,483	1,928,046	13,069,529
1887.....	3,500,000	9,090,342	384,122	12,974,464	1,835,882	14,810,346
1888.....	3,500,000	9,893,057	718,809	14,111,866	2,402,976	16,514,842
1889.....	3,500,000	9,686,827	291,258	13,478,085	3,218,971	16,697,056
1890.....	3,500,000	10,717,472	362,062	14,579,534	3,076,426	17,655,960
1891.....	3,500,000	10,697,679	628,525	14,826,204	4,860,712	19,686,916
1892.....	3,500,000	10,588,703	771,686	14,860,389	4,468,685	19,329,074
1893.....	1,500,000	8,354,482	804,254	10,658,736	2,777,165	13,435,901
1894.....	1,500,000	6,430,073	543,585	8,473,658	2,184,946	10,658,604
1895.....	1,500,000	8,481,789	471,027	10,452,816	2,976,269	13,429,085
1896.....	1,500,000	7,209,787	316,804	9,226,591	2,369,943	11,596,534
1897.....	1,500,000	7,184,822	613,981	9,298,803	2,571,428	11,870,231
1898.....	1,500,000	9,463,262	437,641	11,400,903	2,164,976	13,565,879
1899.....	1,500,000	13,267,287	344,906	15,112,193	2,734,985	17,847,178
1900.....	1,500,000	14,582,627	584,903	16,667,530	3,480,612	20,148,142
1901.....	1,500,000	16,296,688	685,642	18,482,330	3,866,626	21,868,956
1902.....	1,500,000	18,653,625	851,673	21,005,298	4,677,549	25,682,847
1903.....	3,500,000	19,944,369	953,597	24,397,962	4,665,589	29,063,551
1904.....	3,500,000	12,298,455	7,131,577	22,930,036	5,725,927	28,655,963
1905.....	3,500,000	20,559,910	3,562,069	27,621,979	5,586,636	33,208,615
1906.....	3,500,000	18,667,804	10,452,037	32,619,841	6,506,922	39,126,763
Total.....	\$75,375,000	\$289,649,467	\$35,793,974	\$400,818,441	\$81,287,773	\$482,106,214

SILVER (Fine Ounces).

1880.....	\$464,063	\$3,867,188	\$273,023	\$4,604,274	\$112,148	\$4,716,422
1881.....	154,687	4,563,281	286,945	5,004,913	137,672	5,142,585
1882.....	154,687	4,006,920	340,544	4,347,131	164,665	4,511,796
1883.....	154,687	3,576,143	119,883	3,850,713	434,595	4,285,308
1884.....	154,687	3,480,469	502,734	4,137,890	131,484	4,269,374
1885.....	154,687	3,511,310	48,501	3,714,498	357,472	4,071,970
1886.....	154,687	2,804,635	638,562	3,597,884	312,589	3,910,473
1887.....	154,687	3,173,208	506,595	3,834,490	371,719	4,206,209
1888.....	154,687	5,010,218	597,082	5,761,987	504,318	6,266,305
1889.....	154,687	5,644,495	508,920	6,308,102	472,582	6,780,684
1890.....	154,687	5,525,155	963,254	6,443,096	495,077	7,138,173
1891.....	154,687	5,637,642	971,516	6,763,845	663,707	7,427,552
1892.....	154,687	5,572,006	966,643	6,693,336	500,706	7,194,042
1893.....	77,344	5,082,054	1,346,326	6,505,724	945,787	7,451,511
1894.....	77,344	6,635,685	759,824	7,472,853	944,504	8,417,357
1895.....	77,344	7,599,323	752,942	8,429,609	1,065,902	9,495,511
1896.....	77,344	6,160,777	821,387	7,059,508	832,860	7,892,368
1897.....	77,344	7,116,009	616,579	7,809,932	853,457	8,663,389
1898.....	77,344	9,417,981	489,160	9,984,485	734,233	10,718,718
1899.....	77,344	8,388,658	529,137	8,995,139	1,583,678	10,578,817
1900.....	77,344	10,423,485	940,450	11,441,279	1,776,006	13,217,285
1901.....	77,344	11,809,418	1,038,409	12,925,171	1,208,523	14,133,694
1902.....	77,344	15,236,711	1,289,623	16,603,678	2,741,331	19,345,009
1903.....	77,344	15,016,256	954,930	16,048,530	3,919,726	19,968,256
1904.....	77,344	16,629,834	1,218,122	17,925,300	2,554,687	20,479,987
1905.....	77,344	16,580,307	2,754,003	19,411,654	4,289,023	23,700,677
1906.....	77,344	15,231,628	2,734,187	18,043,159	3,810,105	21,853,264
Total.....	\$3,403,123	\$208,600,796	\$22,969,281	\$234,973,200	\$31,918,556	\$226,891,756

LOUIS KAHN

MOSES KAHN

SAMUEL H. LEVY

L. & M. Kahn & Co.

Importers and Cutters of

DIAMONDS

170 Broadway, cor. Maiden Lane, New York

AMSTERDAM: 2 TULP STRAAT

CUTTING WORKS: 29 GOLD STREET

Arnstein Bros. & Co.

Importers and Cutters of

DIAMONDS

65 Nassau Street

New York

LONDON: Audrey House, Ely Place

AMSTERDAM: 6 Tulp Straat

ALBERT LORSCH

N. Y. Telephone Call, 2161-2 John

ALFRED KROWER

ALBERT LORSCH & CO.

LORSCH BUILDING, 37 and 39 MAIDEN LANE, NEW YORK

131 Washington Street, Providence, R. I.

HEADQUARTERS for CORAL

Coral Cameos

Coral Boutons

Coral Strings

Coral Pendants

Coral Flowers

Coral Cabochons

The Government institution at \$18,479,762, of foreign gold \$706 and \$10,451,331. In addition to these amounts, in the same year \$343,496 worth of United States coin was used in private refineries, while of gold secured from old jewelry the Government institution supplied \$4,116,819 and private institutions \$2,090,063.

Of the silver used in the industrial arts during the same year the sources of supply were as follows:

	Supplied by		Total.
	Government institution.	Private refineries.	
	Fine ozs.	Fine ozs.	Fine ozs.
Domestic bullion..	1,490,662	13,740,966	15,231,628
Foreign material..	2,472,486	261,701	2,734,187
U. S. coin.....	205	1,500	1,705
Old jewelry.....	519,179	3,290,926	3,810,105
Total	4,482,532	17,295,093	21,777,625

Exports of Jewelry, Clocks, Watches, Silverware and Kindred Lines from the Port of New York.

WASHINGTON, D. C., April 1, 1908.—The following were the exports of jewelry, silverware, optical goods, clocks, watches and kindred lines from the Port of New York for the week just ended:

- Bombay: 30 cases watches, \$581.
- Bremen: 1 case jewelry, \$220; 3 cases plated ware, \$310; 7 cases watches, \$8,356.
- Buenos Aires: 1 case watches, \$1,029; 24 cases locks, \$446; 3 cases plated ware, \$259.
- Calcutta: 172 cases clocks, \$2,335.
- Christiania: 8 cases clocks, \$358.
- Chaux de Fonds: 1 case watches, \$125.
- Colon: 2 cases optical goods, \$200.
- Fremantle: 188 cases clocks, \$2,157; 1 case watches, \$210.
- Glasgow: 177 cases clocks, \$1,169.
- Guayaquil: 1 case jewelry, \$285.
- Havana: 8 cases plated ware, \$291; 3 cases plated ware, \$225; 20 cases clocks, \$258.
- Havre: 1 case silverware, \$100; 3 cases jewelry, 123; 1 case optical goods, \$610.
- La Guayra: 4 cases plated ware, \$330.
- Liverpool: 1 case silverware, \$508; 69 cases locks, \$1,708; 3 cases plated ware, \$125; 5 cases jewelry, \$3,741; 3 cases watches, \$70; 113 cases locks, \$1,918.
- London: 14 cases clocks, \$300; 7 cases plated ware, \$122; 9 cases optical goods, \$3,678; 2 cases ropes and views, \$458; 2 cases watches, \$129; 1 case jewelry, \$125; 3 cases thermometers, \$364; 6 cases clocks, \$2,452; 1 case plated ware, \$135; 1 case jewelry, \$1,120.
- Manchester: 26 cases clocks, \$211.
- Montevideo: 1 case watches, \$192; 1 case plated ware, \$250.
- Nassau: 1 case jewelers' supplies, \$115; 3 cases plated ware, \$156; 15 cases clocks, \$1,500.
- Oporto: 60 cases clocks, \$361.
- Port Limon: 16 cases clocks, \$549; 8 cases locks, \$325.
- Rio de Janeiro: 1 case watches, \$302; 1 barrel jewelers' sweepings, \$317; 1 case optical goods, \$20; 1 case watches, \$246; 1 case watches, \$642.
- Rotterdam: 1 case watches, \$150.
- St. Johns: 11 cases clocks, \$138.
- Sydney: 45 cases clocks, \$1,002.
- Sheffield: 12 barrels jewelers' ashes, \$6,000.
- Stockholm: 4 cases clocks, \$170; 9 cases clocks, \$84.
- Southampton: 25 cases watches, \$4,669; 3 cases ereoscopes, \$547; 7 cases watches, \$1,316.
- Valetta: 8 cases clocks, \$212.
- Wellington: 14 cases clocks, \$415.

M. Meyer, Marion, Ind., has leased a large and newly furnished store into which he has moved his stock. The establishment is equipped with new fixtures and show cases.

Amos K. Diefenbaugh, West Alexandria, Mo., has retired from the retail jewelry business in which he had been engaged for about half a century, and in the future will devote his entire attention to repair work.

REIGNING PARIS FASHIONS.

JEWELRY NOVELTIES SEEN IN FRANCE'S CAPITAL.

PARIS, March 31.—Parasol handles are now within the domain of the jeweler more than the umbrella maker, and have developed into *objets d'art* rather than articles of utility. Animals and birds play an important role in their decoration, the first impetus showing birds and animals' heads carved out of wood and colored like nature, although somewhat of crude appearance. The jeweler, seizing the idea, began to fashion handles of high price in gold and silver, the precious marbles and quartz, engraved glass, painted porcelain and various other substances which lent themselves admirably to this high art work. Especially are the exquisitely veined quartzes suitable for umbrella and parasol handles *de luxe*, amazonite in both light and dark colors, New Zealand green stone, the milky green of Chinese jade, with the exquisite rose-quartz with its lovely color and markings; white quartz, Labrador red jasper, carnelian, lapis lazuli, malachite, silex and agate. Turquoise, amethyst and opal-matrix are also employed and lend infinite variety to handles destined for high-class parasols.

Long handles of rose-crystal show the tops encrusted with topaz or tiny chip diamonds, while others are ringed with transparent white crystal, or white quartz is encircled with a ruby-headed serpent or banded with what looks like a finger ring set with turquoise, amethyst or other semi-precious stones. There are faceted handles of amethyst matrix with a delicate gold network, others of rock crystal encrusted with rubies, emeralds or turquoise. Great knobs of crystal faceted and gold banded, and others as big as a marble of Russian malachite or deep blue lapis.

Animals and birds are expressed in precious marble and quartz, a polar bear in amazonite afloat on an ice floe of whitey-green translucent quartz, a crystal fish with gold-banded throat, swimming upon a lake of Chinese jade. Rabbits are a favorite design, pale-green and brown rabbits with immense ears and ruby eyes appear to be in chase of some unknown object, or are couchant on a crystal plaque. Cats and dogs, usually in gold repoussé on a marble top; gold and silver swans, the head and neck forming the useful crook, are artistically carved and delicately *ciselé*, while a duck's head in blue-green marble and a pheasant in iridescent enamels, all contribute to miladi's taste for splendor.

Less expensive are handles of painted Saxe, of Wedgewood, of white, blue and orange Sevres, while others come in solid colors and show Empire or Louis XV. designs in gold. Others are of silver gilt pierced or etched, while the artistic damascene work of Spain is also seen in the most intricate patterns, gold inlays on a background of black in the shape of crooks, knobs and long handles. A bird's beak in gold holds an immense baroque pearl in its beak, while a frog, a chameleon, or a serpent in brilliant enamels lends variety to the collection of artistic designs.

The opal is one of the favorite vehicles of the French artist, its iridescent sheen being well adapted for the expression of certain forms. While one has never beheld

a tiger in the coloring of this beautiful gem, a brooch in which the king of the jungle carved out of an opal and stalking on a costly desert of diamonds and rubies, did not appear out of place.

With certain jewelers there is a leaning toward *cinqe cento* designs, ponderous pendants, some showing the head of the virgin or similar design in rude hammered gold, with here and there a spot of blue or red enamel looking like a bit of illumination from some ancient monkish missal. Rather mediæval in conception is an ar-regular shaped pendant extremely large, which shows a lake of dark-blue enamel with rushes and lotos flowers in vari-colored gold, while in the limpid water a swan in gold in high relief disports its graceful form. Rings which are slender and quite reach the finger joint are some of them exquisite examples of the goldsmith's art. A pretty one for a young girl consisted of two daisies in gold with pearl centers and rather incongruously connected by a coil serpent in green enamel.

The cross as an article of adornment for young girls is very popular, and on account of its religious signification is used as a first communion offering. For this purpose they are far from showy, plain ones of dead or burnished gold about two or three inches long, others of gold with a central pearl, while more elegant ones are encrusted thickly with small white pearls. Occasionally this dead whiteness is relieved with a diamond center, but the young French girl is rarely offered aught but gold and pearls.

Gold chain purses show little variety, but now have two convenient divisions instead of the single one formerly made. A shirred *aumoniere* of the finest gold links showed the top frill and the bottom fringed heavily with oval baroque pearls, while another with a clasp of solid gold was enriched with big amethysts.

A beautiful art object is a brooch at least a finger long, in a pattern of small black-berry leaves entwined with berries of tiny pearls encrusted on a golden framework, while in the center is a dark amethyst an inch square. A new style bracelet was formed of narrow plaques of some blue-green stone between open work turquoises and diamonds in the shape of an X. More and more is the use of black enamel as a background for a delicate tracery in diamonds becoming general, the black affording a relief for an intricate design.

The lingerie idea in neck ornaments is much exploited, a novel but not wholly artistic creation being two points like those of an embroidered linen collar turned over on a wide black velvet band. The lace and embroidery was developed in small rubies and diamonds.

Very ornate is a buckle of reddish-gold clasped with a gold and enameled dragon fly. New hat pins show big cats' heads in beaten gold with touches of black enamel like fur.

A very narrow black moire ribbon is a favorite throat decoration, the one in question being connected in front with slender silver chains, each one tipped with an enormous jewel, one a straw-colored diamond and the other a great blazing ruby.

COUNTESS DE MONTAIGU.



TRADE-MARK

RINGS



TRADE-MARK

RINGS are always in demand, and are always salable, provided you have the right kind to sell. We have—

RINGS of every description: signet rings, diamond rings, fancy rings, rings of every style and combination of stones.

RINGS that satisfy the most critical and appeal to every taste and fancy.

RINGS You can sell. *Write us or wire us any time. We are always ready for your order.*

HAYDEN W. WHEELER & CO., Importers

AMSTERDAM, 2 Tulp Straat 2 Maiden Lane, NEW YORK, N. Y. LONDON, 50 Holborn Viaduct
Phone, 7365 Cortlandt

EDUARD VAN DAM

CUTTER OF

DIAMONDS

CUTTING SHOPS:

ANTWERP
 41 Rue de la Province (Sud.)
CABLE ADDRESS, MADNAV

NEW YORK
 437-439 Fifth Ave.
 Cor. 39th St. Knabe Bldg.
TELEPHONE. 5879 38TH ST.
 CABLE ADDRESS DEVRIVAN

AMSTERDAM
 55 Ruysdaelstraat
CABLE ADDRESS, MADNAV

LONDON OFFICE, 22 Holborn Viaduct

AMSTERDAM
 2 Tulpstraat

LONDON
 40 Holborn Viaduct

OPPENHEIMER BROS. & VEITH.

CUTTERS OF DIAMONDS.

Cutting Works
 43-45-47 John Street

NEW YORK
 65 Nassau Street

RUDOLPH NOEL

PHILIP NOE

RUDOLPH NOEL & CO.

IMPORTERS AND CUTTERS OF DIAMONDS

2 Tulp Straat, AMSTERDAM

37-39 Maiden Lane, NEW YORK

THE NEWS FROM ENGLAND

Business Bad Throughout Jewelry Trade and Colonies Buying Little—Complaint Against Methods of German Manufacturers Who Use False Marks—Newspaper Reports Hurt Diamond Trade—Diamond Prices to Be Maintained—Declaration Required from Manufacturers and Wholesalers by N. A. G.—Laws Against False Description of Plated Ware to Be Enforced—London Jewelers Ask for Day Classes in Design.

LONDON, March 28.—Trade throughout the United Kingdom is very bad. It would seem as if a change for the better were impossible, for the Board of Trade returns still show a falling off. In London it would be indeed difficult to find a silversmith's shop working full time, but with considerable ease one could quite easily find quite a number where the men are not attending the workshop more than a few days per week. There is just one solitary firm, however, working full time, but the reason is not that they are more fortunate but that they are determined to make a good show at the Franco-British Exhibition which opens early in May, and are speculating in the production of special pieces to exhibit. The jewelry trade is no better and the alarmist chatter of the daily press concerning the diamond market does not help matters at all. If we study the condition of Birmingham the same doleful story must be told, although things are not quite so quiet there as in London. Sheffield is having a very bad time. The electroplate and table cutlery trades are most unsatisfactory and the silver trade also. Many firms open on Tuesday and close again on Friday night, and even then the workpeople are not working the whole of the four days.

Besides the depression in the home markets the colonies do not appear to be buying well except Australia, but Canadian demands are considerably less than for several years past. Right throughout the country the same unfortunate condition of affairs obtains, and watch manufacturers and the importers also complain bitterly.

* * *

The scandalous methods adopted by some German manufacturers were described to the Board of Trade by a deputation of leading Sheffield worthies representing the ancient Cutlers' Co., the Sheffield Chamber of Commerce, the Federated Trades Council and the Cutlery Council. Stuart Wortley, M. P., who introduced the deputation, urged that the Merchandise Marks Act of 1887 was practically useless to protect British manufacturers, and indeed it had only been a legalized means of compelling foreign makers to receive a gratuitous advertisement. Stupid as it might be to compel the foreigner to mark his goods "Made in Germany" or Austria, the Act did not keep out a number of goods which came in unmarked, neither did it afford any protection against the unscrupulous German manufacturer who marked his goods "Sheffield" and exported them to British Colonies or America, the goods unfortunately being too often absolute rubbish and thus not only filching the trade which Sheffield should have, but also injuring, oftentimes beyond repair, the good name the city has earned for its fine cutlery productions, etc. The deputation requested greater vigilance on the part of the cus-

toms officials so as to render the passing of unmarked foreign goods as British. The Master Cutler suggested that instead of compelling the name of the country of origin to be placed on goods, the words "not British" should be compulsory. The representative of the men, 20,000 of whom are in the trade unions, said they were satisfied with the principle of the Act of 1887, but it would be more useful if amended. The parliamentary secretary of the department, however, did not give the deputation any hope of drastic reform. What has been termed the diamond scare is a question which, whatever answer one gives, is continually cropping up. There can be no doubt whatever that business during the past month has been exceedingly quiet. Buyers refuse to purchase despite the fact that manufacturing jewelers and the big retail houses which buy their own goods for mounting are very short in their stock. Certainly the daily papers have been, here as in America, doing their very best to make a scare among the public, and the public is easily scared, with a consequence that trade has been extremely quiet; but the fact remains that there is little possibility of diamonds reaching a lower point than that at which they stand at present in the general market. I have made inquiries at the headquarters of both De Beers and the Premier companies, and they positively assure me that so far as they are concerned there will be no reduction in price and that the "twaddle" with respect to their competing one with the other is absolutely without any reasonable ground. As a matter of fact both the companies will take great care to maintain prices. Chatting with a well-known dealer on Holborn Viaduct, I was assured that as the month is ending some of the most important retail houses are preparing themselves for a possibility of good trade during the Summer.

Some little time back THE CIRCULAR-WEEKLY published a photograph of the teachers and some of the students of the Central School of Arts and Crafts, and it may interest my readers to learn that on March 21, 81 students of the school sat down to a banquet in the City of London under the presidency of W. Augustus Steward, chief instructor, supported by Prof. Lethaby, the principal of the school, and other leading members of the industry. I think perhaps this is something unique in the way of a technical school, particularly as the banquet was arranged by the boys themselves.

* * *

Perhaps it will interest the readers of THE CIRCULAR-WEEKLY if I include in my notes the declaration which has to be made by the wholesale and manufacturing jewelers, silversmiths, watchmakers and opticians before they are placed upon the "In Accord" List of the National Associa-

tion of Goldsmiths: "To the Executive Council and Members of the National Association of Goldsmiths: Gentlemen,—We hereby signify that we are in accord with the principles of the National Association of Goldsmiths, as set out in the programme of the Association *i.e.*, 'We do not trade direct with the public, we have no vested interests in retail shops, neither do we distribute our catalogues and price lists to others than the legitimate trade.'" In sending this to those engaged in the wholesale trade the general secretary points out that one of the principal objects of the Association is to combat unfair direct trading by the wholesale and manufacturing houses, asserting that he knows of a hundred firms who do this kind of unfair business.

* * *

Speaking of the National Association of Goldsmiths, I might say a word with regard to the Scottish branch which severed its connection therewith. It is making remarkable headway and increasing in numbers every day, so is the Edinburgh and East of Scotland Jewelers' & Silversmiths' Association, which held a record dinner recently. This is looked upon in a way as the aristocratic association because it represents Edinburgh and has in its ranks the merchant princes of the northern trade.

* * *

The question of wrongly describing goods has come very much to the front of late. Some few years back the N. A. G. at its annual meeting held in the Council Chamber of the Guildhall, London, passed a resolution pointing out the importance of careful description in the case of rolled gold and gilt articles, etc., and now the Birmingham Wholesale Jewelers' Association has issued a warning to the trade pointing out what can and will have to be done unless some of the manufacturers keep within the strict letter of the law and rightly describe their productions. There is made in Great Britain cheaper classes of imitation gold goods which are simply gilt and then sold as rolled gold, while unscrupulous manufacturers of other nationalities, American and German for instance, also send in for sale goods of the same type wrongly described, so, perhaps, this note will act as a warning to some of my American readers who may be doing business with Great Britain, and so ensure that they shall keep themselves well within the mark so far as the Merchandise Marks Act is concerned.

* * *

A meeting was recently held in the Hall of the Worshipful Company of Goldsmiths for the purpose of discussing the question of day classes for teaching drawing and design to those employed in the jewelry and silver trades of London. It was possibly one of the most representative gatherings of London manufacturers that has been gotten together for the purpose of discussing the question of education as applied to the business, 65 being present, including representatives of Messrs. Edward Barnard & Sons, the oldest silversmiths in the kingdom; R. & S. Garrard, Wakely & Wheeler, Comyns & Sons, Whitehorse Bros., Wolff, H. A. Byworth & Co., etc., etc. George Heming, a retail jeweler, was responsible

Cameos=Scarabs=Carbuncles

Notwithstanding the difficulty generally experienced at present in supplying the sudden demand for these goods, we have succeeded, thanks to our firmly established connections with the stone centers of Europe, in making arrangements for the uninterrupted supply of them and are, therefore, fully prepared to fill all orders for these articles with the least delay.

CAMEOS

Onyx, Pink and Brown Shell, and Coral

SCARABS and CARBUNCLES

Red and Brown Sard, Bloodstone, Moss Agate, Green Agate, New Zealand and Chinese Jade, Amazonite, Tiger Eye, Coral—Japanese and Italian, and

TURQUOISE MATRIX

L. Heller & Son

Importers of Precious and Imitation Stones
68 NASSAU STREET, NEW YORK

PARIS
39 Rue de Chateaudun

PROVIDENCE
212 Union Street

IDAR
14 Hauptstrasse

ORDER

DIAMONDS

ON MEMORANDUM FROM

ALFRED H. SMITH & CO.

London,
6 Holborn Viaduct.

170 BROADWAY, NEW YORK.
Corner Maiden Lane.
Also 475 FIFTH AVENUE.

Chicago,
103 State Street.

TURQUOISE

Matrix-Turquoise
BEST THE WORLD PRODUCES

Exquisite Color
and Markings



No. 222

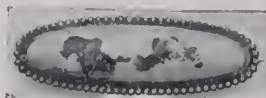

No. 316

SEND FOR CATALOG

Showing 133 different sizes and shapes
of MATRIX-TURQUOISE STONES
ready for Mounting.

The Arizona
Turquoise Mines Co. Inc.

Cutting Works and Sales Office:

171 BROADWAY, NEW YORK
Telephone 5728 Cortlandt

ARTHUR REICHMAN

DEALER IN

AMERICAN BAROQUE PEARLS
65 Nassau St. New York

GEMS AND PRECIOUS STONES

Cloth, Postpaid, \$1.00

Published by

The Jewelers' Circular Pub. Co., 11 John St., N. Y.

for the organization, and in opening the proceedings emphasized the fact that he was desirous that something should be done to establish day classes for drawing and design when boys would have to attend compulsory, say, from five o'clock in the afternoon until seven—that is to say, in the employer's time. Several spoke in support of this suggestion and a resolution was eventually carried to the following effect: "That the classes be held from, say, 5 to 7 o'clock p. m., at the present City and West-end Technical Schools, once (or twice) a week, for drawing and designing in all its branches, under efficient masters, thus enabling the manufacturers in the jewelry and silver trades to make compulsory the attendance of their respective apprentices and improvers."

This having been done, W. Augustus Steward, chief instructor at the Central School of Arts and Crafts, suggested that it would be well if the meeting were to take the matter very seriously, because, despite the passing of that resolution, there were a number of employers who would not even give their boys half an hour's time off when they were attending evening schools and thus demonstrating their desire for further knowledge and improvement in workmanship. H. L. Symonds, a nephew of Armistead, the late Royal Academician, spoke about the difficulties which had been experienced with the Saturday morning classes, and also the fact that somehow the silver trade did not seem to offer great opportunities to really talented designers and modelers. Mr. Symonds, who was recently unanimously elected to the chairmanship of the London Wholesale Jewelers and Allied Trades Association, is the managing director of the old firm of S. Mordan & Co., and when the classes were first established at the Central School of Arts and Crafts he requested Mr. Steward to attend his factory and give an address to his workpeople upon the advantages which were to be obtained from attendance at a technical school. ST. GEORGE.

Importations at the Port of New York.

Weeks Ended March 28, 1908, and March 30, 1907.	1907.	1908.
China, Glass and Earthen Ware:		
China	\$51,874	\$94,576
Earthen ware	13,993	9,502
Glass ware	21,161	16,861
Optical glass.....	1,457	333
Instruments:		
Musical	29,969	15,267
Optical	6,544	10,103
Philosophical	2,220	1,068
Jewelry, etc.:		
Jewelry	19,411	5,854
Precious stones	555,533	119,094
Watches	32,964	12,997
Metals, etc.:		
Bronzes	300	2,379
Cutlery	28,591	32,742
Dutch metal	7,918	9,108
Platina	96,164	2,498
Plated ware
Silverware	3,162	71
Miscellaneous:		
Alabaster ornaments.....	90	75
Amber	8,311	43
Beads	7,011	2,064
Clocks	3,480	1,995
Fancy goods	8,791	10,358
Fans	15,216	3,726
Ivory	544	2,356
Ivory, manufactures of..	455	215
Marble, manufactures of.	41,170	7,335
Statuary	2,360	6,370

Death of Harry A. Scofield.

His many friends in the jewelry trade in New York City were shocked to learn, Thursday, of the sudden death of Harry A. Scofield, of the firm of Scofield, Melcher & Scofield, manufacturing jewelers at 21 Maiden Lane, which occurred at his home in Brooklyn at 5 o'clock that morning. Mr. Scofield was at the office of the concern as usual on the Friday previous, and was seemingly in good health. He remained at the New York office all day, but when he reached his home in Brooklyn Friday night he did not feel well. What appeared to be a cold rapidly developed into pneumonia, which, aided by a complication of other diseases, caused his death. Mr. Scofield was one of the best known and most popu-



THE LATE HARRY A. SCOFIELD.

lar members of the jewelry trade, and enjoyed the acquaintance of an extended circle of friends, who join in expressing their deep regret at his sudden death.

Harry Scofield was born Oct. 6, 1856, in the city of New York, where he obtained his education, and he always made his home in New York and Brooklyn. In 1873 he began his business career, starting with G. & S. Owen as an office boy. By attention to his duties he worked his way rapidly to the position of a salesman and became a trusted employe of the concern. In July, 1883, he went with the firm of Lincoln, Bacon & Co. as a salesman, covering the western territory, and during this time he became well acquainted in the trade in the west.

In 1898 the firm of Scofield, Melcher & Scofield was organized and succeeded the firm of Lincoln, Bacon & Co., D. O. Scofield, a brother of the deceased, becoming president, Woodbury Melcher the treasurer, and the deceased the vice-president and secretary of the concern, and he was identified with it up to the time of his death.

Mr. Scofield was a member of the Jewelers' League, the Brotherhood of Traveling Jewelers, the Traveling Jewelers' Association, and the Philadelphia Jewelers' Club. He was also a member of the Chicago Ath-

letic Association. He is survived by a widow, four brothers and two sisters.

The funeral services were held at the deceased's late residence, 369 Washington Ave., Brooklyn, Saturday evening at 8 p. m., and were attended by a large representation of friends and acquaintances in the jewelry district. The interment took place Sunday morning in Greenwood Cemetery.

The Career of the Late Eli Hertzberg.

SAN ANTONIO, Tex., April 1.—The death of Eli Hertzberg, March 24, which occurred at his home, 521 Macon St. and resulted from acute indigestion followed by heart trouble, was a great shock to his many friends in this city, and in his passing San Antonio loses one of its most prominent Jewish citizens, as well as one of its oldest and best known jewelers.

Mr. Hertzberg, who was 62 years old, had been a resident in this city for over 30 years, during all of which time he had been in the jewelry trade and at his death was the proprietor of the E. Hertzberg Jewelry Co., 329 W. Commerce St. He is survived by a widow and a son, Harry Hertzberg, who is an attorney.

Deceased was born in Curland, a province of Russia, but came to the United States when about 10 years old. Early in life he began business as a peddler, and about 44 years ago came to Texas. After locating at various places he started in the jewelry business in Austin in the early '70's with a Mr. Ronvan, and in 1878 moved to San Antonio and opened a store here. At that time he had interests in other parts of the State, but shortly afterwards concentrated his business at this point and took over the entire interests himself. Mr. Hertzberg's ability as a business man was shown by the success which he made as a jeweler, and during his entire career here he managed and controlled the business which bore his name. For a short time his brother-in-law, Max Goodman, had a nominal interest in the business, but this ended in January, 1907. Mr. Hertzberg was an active member of Temple Elbethel, and also prominent in the Masonic Order.

Trustee Appointed for the Business of T. Sorensen, Denver, Colo.

DENVER, Colo., April 1.—The business of T. Sorensen, 404 16th St., has been turned over to creditors to satisfy their claims, and Chas. Brink, formerly of the Boyd Park Jewelry Co., has been appointed trustee to dispose of the stock and distribute the proceeds pro rata. This plan was adopted in preference to bankruptcy proceedings.

The liabilities are about \$2,500 and assets \$1,500, the largest creditors being the Lewis Jewelers' Supply Co. and the W. W. Hamilton Jewelry Co.

Mr. Sorensen has been engaged in business about two years. He was formerly in the employ of the Boyd Park Jewelry Co., by whom he was highly regarded.

The jewelry store of Smith Bros., Elkins, W. Va., was recently damaged by fire to the extent of \$2,500.

Arthur Y. Boswell, Tulsa, Okla., is erecting a new building, and has ordered a \$4,000 outfit of fixtures from Grand Rapids, Mich.

Chester Billings & Son

1840

Successors to
Kandel, Barmore & Billings

1908

Importers of Diamonds
Other Precious Stones, and
Pearls, Diamond Jewelry

1840, Kandel & Barmore; 1866, Kandel, Barmore & Co.; 1880, Kandel, Barmore & Billings; 1897, Chester Billings & Son

New York, 58 Nassau Street, 29 Maiden Lane
London: 22 Holborn Viaduct, E. C. Paris: 53 Rue de Chateaudun
Amsterdam: 2 Tulp Straat

GEORGE H. HODENPYL.

WALTER N. WALKER.

HODENPYL & WALKER

IMPORTERS OF

DIAMONDS

OTHER PRECIOUS STONES
AND PEARLSMANUFACTURERS OF
FINE DIAMOND JEWELRY

373 FIFTH AVENUE,

NEW YORK

Corner 35th Street

Telephone, 5093 Madison Square

CHAS. F. WOOD & CO. DIAMONDS

1 MAIDEN LANE

NEW YORK

EISENMANN BROS.

IMPORTERS OF

Pearls and Precious Stones

452 Fifth Avenue, New York

cor. 40th St., Knox Building

3 Rue St. Georges, Paris.

CENTENNIAL TIMERS

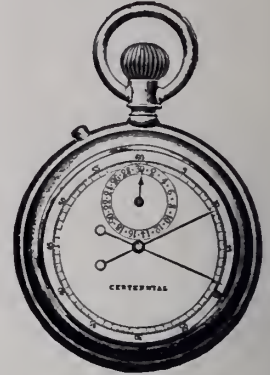

Without question the best plain and split second timers made.

Register with scientific precision. Substantially built and mechanically perfect.

Invaluable for athletic, mechanical and scientific observations. Cased in nickel. Much in demand during the racing season.

We also carry split chronographs with minute registers, cased in gold, gold filled and sterling silver.

All makes of American cases and movements.



Cross & Beguelin

31 Maiden Lane, N. Y.

Established
1863Telephone
480 John

Death of Charles E. Bliss.

ATTLEBORO, Mass., April 3.—Charles E. Bliss, for 27 years a strong and leading figure in the jewelry manufacturing industry in this town, passed away Wednesday at Sea Breeze, Fla. His death was a distinct shock to the family as well as friends, for while it was known he had not lately enjoyed the rugged health of years ago, yet no one suspected that his apparently minor malady could possibly result fatally. Two of his sons had arrived in Attleboro the day previous from Florida, where they had visited him, and on their departure for the

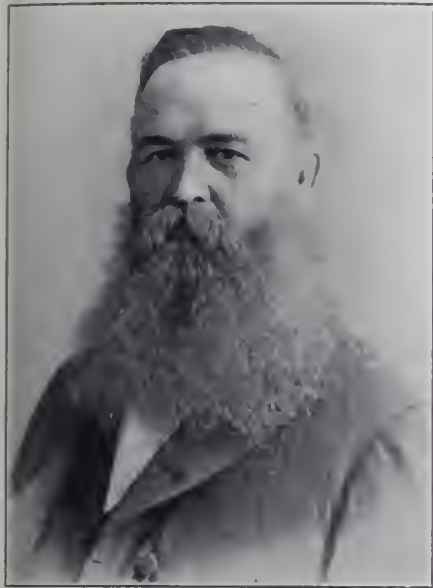

THE LATE CHARLES E. BLISS.

north had not the slightest intimation of the likelihood of his death.

Few men made deeper impress upon the life of Attleboro than did he, and few will be more thoroughly missed, even those who chose to disagree with him in politics or matters of public service being still his personal friends and admirers of his intense industry and high personal integrity. When his business brought him a comfortable competence his time and energy were taken from the factory and devoted unselfishly for years to the town. He was a sincere Christian, and endeavored constantly to apply his ethical principles to his everyday life; he was an ardent believer in the theory that a man owed much of his time and energy to the community, and was ever ready to answer the ceaseless demands made upon him by the town; he was a keen business man, of tireless persistence and judgment, which won him many advantages denied to men of slower mental processes.

Mr. Bliss was born in Attleboro, in the section known as Parmenter's corner. After a public school education he learned the rudiments of the jewelry business, then just springing into marked success with the development of many processes which made it possible to produce handsome goods at lower cost than had been possible before. He made his start on his own account in 1873, with his brother Everett B. Bliss, and R. L. F. Everett, the business

style being Bliss Bros. Mr. Everett was not long with the company, and while a member had to do only with the New York office. Everett B. Bliss also took only a limited part of the responsibility, so that from 1873 to 1901 Charles E. Bliss virtually carried the entire direction of the business on his shoulders. The start was made in the Steam Power building on Railroad St., the cradle of many of the biggest houses the town has ever developed. In February, 1876, the concern moved to the Robinson No. 2 building on the same street, and when the R. F. Simmons Co. erected its large and convenient factory on North Main St., Bliss Bros. removed there, and have made that their industrial home ever since. That it flourished is evidenced by the beautiful estates of Charles and Everett Bliss on Peek St., the wide acres C. E. Bliss owned elsewhere in the town, and many other proofs of large prosperity. Some years ago E. B. Bliss died suddenly at his home, and his brother was left to carry the burden alone.

Advancing years, a competence, and a real desire to be of service to his fellow citizens impelled Mr. Bliss about 1901 to decide upon retirement. He turned the business over to his sons, Herbert C. and Ernest M. Bliss, and withdrew. The sons took out Rhode Island incorporation papers and the concern has since been run as the Bliss Bros. Co.

Mr. Bliss served the town in many capacities. He was chairman of the school committee from 1895 to 1907. Last year he retired from the school board. He was elected selectman and served on the first board which administered the affairs of Attleboro after its separation from North Attleboro. He also served then as an assessor, and was head of what was then called the prudential committee, having to do with town finance, especially the school finances. He was for many years head of the school board, and at the time of his death he was a member of the park commission. He served on the sinking fund commission, was treasurer of the Richardson school fund, vice-president of the North Attleboro Savings bank, and a deacon of the Second Congregational church. Outside of local interests he was last year candidate for representative to the legislature. He was a member of Ezekiel Bates lodge of Masons, and one of its worshipful masters. He was also a member of Pennington lodge, A. O. U. W., and the Royal Arcanum. He leaves a widow, two sons and two daughters. Last June he and his family celebrated his golden wedding.

In recognition of his manifold services to the town the selectmen adopted resolutions and spread them on the records, and other public and private bodies will do likewise. The Masons will conduct his funeral, Rev. J. Lee Mitchell officiating.

D. A. White Co., Attleboro, Mass., Makes an Assignment to David E. Makepeace.

ATTLEBORO, Mass., April 4.—Papers were filed this week giving notice of the assignment of the D. A. White Co., manufacturing jewelers in the No. 2 Robinson building, to David E. Makepeace, of the D. E. Makepeace Co., for the benefit of

creditors. Treasurer Damon A. White made the assignment.

The property, according to present outlook, will be converted into money by an early sale. Mr. Makepeace states that about two weeks will be required for a complete inventory and examination of the affairs of the concern. Until this is completed and he is prepared to make a detailed and accurate report, no steps will be taken toward a meeting of creditors.

Mr. White states it is impossible to assign any one special cause for this failure, which is the first of its kind in the town in a long period, but ascribes it to a combination of conditions growing out of the present depression.

Death of Uriah C. Smith.

BROCKTON, Mass., April 3.—Uriah C. Smith, for the past 21 years proprietor of a jewelry and optical establishment at Main and Church Sts., died this afternoon of pleuro-pneumonia, after a brief illness. He was taken sick a week ago, but the attack seemed of minor consequence, and its development into pneumonia yesterday morning was a surprise and shock to his family and friends. He received constant attention, but lacked the vitality to successfully combat the malady.

Mr. Smith was born in South Ely, Canada, his father being a Baptist clergyman. The family removed to Fall River when Mr. Smith was about six years of age, and he received his early education in the schools there. Early in life he learned the jewelry trade from A. B. Bruneau, and a little over 21 years ago Mr. Smith came to Brockton to follow the business he had learned, taking small quarters at 92 Main St., corner of Church St.

He started in a modest way, his little establishment having but one show window, and he being the only one employed. The business grew until he took first the entire street floor, then the second floor, and then a large section in the rear of the street floor. At the time of his death his force of salesmen had increased to nine, he had turned over the optical department to a special manager, and prosperity and a desirable standing in the community had come to him, not merely as a result of his business successes, but also through his characteristics as a man.

Deceased was of genial, social disposition, and was a member of the Commercial Club, the Thorney Lea Golf Club, the branches of Masonry in this district and Aleppo Temple of the Mystic Shrine in Boston, Electric Lodge, I. O. O. F., Banner Lodge, N. E. O. P., and the Brockton Roque Association. He attracted attention in the latter body by offering the U. C. Smith trophy cups, played for annually by the clubs affiliated with the association. He was also an attendant at the Church of the Unity.

Mr. Smith leaves a widow, who, before marriage, was Miss Lydia A. Baker, to whom he was united a little over 17 years ago at her home in Fall River. He also leaves two children, Dorothy, aged 12, and Arthur, aged 7.

BROCKTON, Mass., April 6.—The funeral of U. C. Smith, held this afternoon, was most impressive. Many business houses closed their doors during the service.

ADDISON W. WOODHULL, President.
FRANK K. HUFF, Vice-President.

GILBERT T. WOODHULL, Treasurer.
WILLIAM J. McQUILLIN, Secretary.

MOUNT & WOODHULL,

IMPORTERS OF

DIAMONDS,
OTHER PRECIOUS STONES,
PEARLS, ETC.

MAKERS OF

FINE
DIAMOND
JEWELRY.

26 Maiden Lane,
(Southwest Corner Nassau Street)

NEW YORK

EMERALDS, DIAMONDS AND PEARLS

CABLE ADDRESS: MILBAGG

BAGG & CO.

Successors to BAGG, PERINE & CO.
IMPORTERS
452 FIFTH AVENUE, at 40th Street
NEW YORK

TELEPHONE NUMBERS: 917-918 BRYANT

RUBIES AND SAPPHIRES

Pearl Necklaces and Collarettes.

Mounted Diamond Jewelry of every description.



Emil Knopf, John W. Rueler, Frank L. Wood.

Largest assortment of all kinds of very fine, fancy and rare gems, including Pearls, Diamonds, Rubies, Emeralds and Sapphires.

Particularly Fancy Colored and Fancy Shaped Diamonds!

182 & 184 BROADWAY
NEW YORK

QUARTERLY REPORT OF THE NASSAU BANK

at the close of business on the 25th day of March, 1908:

RESOURCES

Loans and discounts	\$4,106,857.04
Liability of Directors as makers	NONE
Due from Banks and Bankers	457,463.10
Real Estate	42,900.00
Mortgage owned	1,000.00
Bonds	224,051.25
Cash in Vaults, viz.:	
Specie	\$457,730.37
Legal Tender	824,463.00
Exchanges for next day's clearings	223,454.89
	\$6,337,919.65

LIABILITIES

Capital Stock	\$500,000.00
Surplus and undivided profits	366,443.72
Deposits	5,445,203.75
Cashier's Check	26,272.18
	\$6,337,919.65

Corner Nassau and Beekman Streets

IMPERIAL WESTMINSTER ELECTRIC CATHEDRAL CHIMES

OPERATED FROM ANY STANDARD CLOCK at ANY DISTANCE by 10 Dry or Wet Batteries

On exhibition at our sales-rooms, 81 Nassau Street, New York.

Received Diploma and Highest Award Medal at the Lewis & Clark Centennial Exposition, Portland, Oregon, U. S. A., October, 1905.

The music of the chimes is the same as the famous Cathedral Chimes of Westminster Abbey, London. Makes a quarter-hour strike of any silent or striking clock, converting it into a wonderful Chime Timepiece.



Registered and Patent Applied For

Special Note—By the old methods, to obtain a Clock Chime Timepiece and the wonderful volume of sound and the sweet, clear tones in the chimes—to be heard at a great distance—they could only be procured at the enormous expense of \$5,000, while our most expensive set is but a slight fraction of this cost.

MANUFACTURED BY
The W. GREEN ELECTRIC CO.
81 Nassau St., New York, U. S. A.

Members of the Jewelers' 24 Karat Club Hold Enjoyable Beefsteak Dinner and Meeting.

Members of the Jewelers' 24-Karat Club of New York to the number of over 50 assembled at Reisenweber's, Columbus Circle, New York, last Friday evening, and partook of a beefsteak dinner, and also attended a meeting of the club. The dinner was most enjoyable from beginning to end, and proved to be such a success that at future business meetings of the club a similar dinner will be given.

The meeting was called to discuss the plans of the club for the coming season and to arrange for the annual outing and other functions to be held by the club during the year.

The members of the club first spent a pleasant half hour in chatting, and a little before 7 p. m. were ushered into the dining room, which was arranged with linen-covered wine boxes in place of tables placed in the form of a large horseshoe. At each box were two chairs and two beer steins. The guests soon found their respective places, which were marked with place cards, and donned aprons and caps. At the head of the gathering when all were seated was President Harry Larter, and on both sides of him and extending down the length of the room on either side were the jolly jewelers ready for the feast. In the center of the room was a large platter of beef embellished with greens.

The dinner started off with the drinking of a toast to the club. The beefsteak was served in delicious slices on bits of bread, and the waiters were constantly on the move to keep the supply equal to the demand. Toasts were drunk to Millard Wheeler, the treasurer of the club, who is in Europe, and to Lou. White, a Philadelphia representative, who in response said: "This is the most pleasant business meeting of the club I have ever attended." He then proposed a silent toast to the memory of Harry Scofield.

Song and jest was the order of the evening and a spirit of cheer and good fellowship prevailed. During the dinner several musical selections were sung by J. Arthur Baker, the diners joining in the choruses.

The assemblage of jewelers presented a unique appearance, dressed in caps and aprons. No two caps were worn the same way.

With the coming of coffee and cigars President Larter arose and explained the object of the gathering. The business of the evening was then taken up. The reading of several reports was followed by a discussion of the plans for the Summer outing. Several plans were suggested, but it was finally decided to hold the outing at Pleasure Bay, N. J., Sept. 12.

The arrangements were left in the hands of the following committees: Outing Committee—Chas L. Powers, G. T. Stebbins, Archie Rutherford, Samuel Kramer and H. R. Conklin. Athletic Committee—E. R. Crippen, J. W. Alford and Percy Savory.

It was decided to have the next annual banquet Friday evening, Jan. 22, 1909, and the arrangements were left in the hands of

the following committees: Dinner Committee—C. F. Brinck, Leo Wormser, W. T. Gough, Samuel H. Levy, Mathias Stratton and L. P. White. Speakers' Committee—John L. Shepherd, E. R. Crippen and C. F. Brinck.

The following new members were admitted to the club: Benjamin F. Rees, Henry B. Zimmern, Frank C. Osmer and P. Clust. The new associate members are L. H. Carpenter, R. H. Schley, E. B. Lapham, W. F. MacDonough, W. T. Woodruff, Wm. Tarlton, F. W. Stanbrough and J. M. Lissauer.

Col. Shepherd was called upon to speak and talked of the next banquet and promised to obtain the best possible speakers. He also urged the members to be careful as to those whom they invite to the banquet. He said that he had never had an opportunity before of talking to so many 24-Karat Club jewelers. He told an amusing story and recited a poem which he himself wrote. He also told a touching story of self-sacrifice shown by a mother, and concluded by suggesting that at some time a dinner be given by the club to the wives, mothers and daughters of the members.

The business of the evening was interspersed by a programme of song and magic. The talent represented included, besides Mr. Baker, Helen Darman and Mildred Kenfield and Professor Ausbach. The card tricks of the "professor" called forth exclamations of surprise on all sides. He was voted "all right."

The gathering broke up about 11 p. m. after a most enjoyable and profitable evening.

Those present included H. C. Larter, Chas. L. Power, Geo. T. Stebbins, David C. Townsend, C. F. Brinck, David Kaiser, John W. Sherwood, Samuel H. Levy, Adolph Schwob, J. Warren Alford, Alfred Krower, P. H. Savory, Geo. R. Whitehead, E. C. Jamison, H. R. Benedict, James R. Gleason, R. G. Monroe, Louis P. White, F. W.

Stanbrough, Wm. H. Kinna, William T. Gough, John L. Shepherd, Leo Wormser, Archie Rutherford, M. Gattle, J. M. Lissauer, Bennet Osborn, Jr., A. L. Stearns, Geo. D. Merrill, Harry Canfield, S. E. Bolles, M. L. Bowden, Jr., Robt. B. Steele, A. G. Van Houten, W. L. Washbourne, Robt. H. Klitz, W. H. Wright, Matt. Stratton, W. H. Tarlton, Henry Bodenheimer, M. G. Levy, A. Rosenthal, H. N. Eliassof, "Jack" Townsend, J. E. Bennett, A. A. Kahn, E. B. Lapham, W. T. Woodruff, R. W. Adams, H. B. Zimmern, P. Clust, Wm. I. Rosenfeld, Wm. A. Bryant, Benj. F. Rees, F. W. Trewin, A. M. Clark, A. Beuke.

Career of the Late H. A. Capron.

ATTLEBORO, Mass., April 3.—In the death, March 30, of Harford A. Capron, whose demise was briefly noted in the last issue of THE CIRCULAR-WEEKLY, Attleboro lost a pioneer jeweler, an inconspicuous but valuable citizen, and a public spirited man. His entire life, lacking but one year of four score, had been passed in Attleboro.

Deceased was the son of Dennis Capron, and on his mother's side was related to the Hodges family, several of whose members have figured in the jewelry industry. After acquiring his public school education he learned the trade of a jeweler. Being ambitious to start on his own account, he became a partner in Capron & Coe, but soon after withdrew and took as associates his nephews, Frank and Herbert Capron, the business style being H. A. Capron & Co. Their career was successful, and the profits which accrued were invested in well-selected real estate, so that before reaching 60 he decided to retire from active business life. Taking residence on County St., his declining years were quietly spent, occupied with the care of his estate and attention to his numerous buildings.

Mr. Capron is survived by a brother and sister. He was a member of the Masonic and Odd Fellows' fraternities, and one of the donors of Capron park to the town of Attleboro. His funeral was held at his late home to-day.

National Monthly Import and Export Statistics.

WASHINGTON, D. C., April 1.—The records of the Treasury Department contain the following comparative statistics of interest to the jewelry trade for February, 1907, and for the eight months ended February, 1908:

	IMPORTS.		—8 Months Ending—	
	Feb., 1907.	Feb., 1908.	Feb., 1907.	Feb., 1908.
Clocks and parts of.....	\$31,358	\$19,077	\$459,536	\$397,908
Watches, materials and movements.....	189,847	134,373	2,032,266	1,862,837
Diamonds, glaziers' diamonds, etc., not cut, and watch jewels (free).....	1,233,074	34,697	8,133,767	3,761,763
Diamond dust or bort (free).....	1,725	4,384	64,285	50,187
Diamonds, not set (dutiable).....	2,258,618	147,179	17,080,332	8,306,853
Precious stones, rough or uncut (free).....	4,975	3,221	85,817	89,975
Precious stones and pearls, not set (dutiable)....	437,926	93,809	5,252,072	2,212,681
Jewelry and manufactures of gold and silver.....	150,246	131,942	1,271,319	1,255,684
EXPORTS OF FOREIGN MERCHANDISE.				
Clocks and parts of.....	\$50	\$15	\$638	\$886
Watches, materials and movements.....	10	8,165	4,416	10,141
Diamonds, rough, including miners', glaziers', etc.....	9	2,349
Diamonds, not set (dutiable).....	100	15,277	30,818
Precious stones and pearls, not set (dutiable)....	322	33,979	17,546
Jewelry and manufactures of gold and silver.....	1,474	188,382	21,686	2,019,676
EXPORTS OF DOMESTIC MERCHANDISE.				
Clocks and parts of.....	\$108,042	\$120,782	\$904,973	\$1,019,016
Watches and parts of.....	143,099	77,689	1,184,523	993,717
Jewelry and manufactures of gold and silver.....	193,943	107,420	1,413,484	1,169,613
Plated ware.....	62,985	32,308	550,939	533,169

W^M S. HEDGES & CO.,
 IMPORTERS AND CUTTERS OF
DIAMONDS.
 Precious Stones and Pearls.
170 Broadway, Corner Maiden Lane, New York.
 27 Holborn Viaduct, London.

CATSEYES
SAUNDERS, MEURER & Co.
 65 NASSAU STREET NEW YORK

F. A. JEANNE
Star Rubies and Sapphires
 5 Square de l'Opera PARIS, FRANCE
 Cable Address
"GEMFINDER"
 Western Union Code

STERN BROS. & CO.,
 CUTTERS OF
DIAMONDS,
 CUTTING WORKS:
138-142 West 14th St., N. Y. 68 Nassau St.,
NEW YORK.
 CHICAGO, LONDON.
 103 State Street. 29 Ely Place.

Tel. 4457 } Cort. **JOHN M. RICHARD** 2 MAIDEN LANE
 4458 } Room 302, NEW YORK
American Pearls and Baroques
MATCHED PAIRS FOR EARRINGS The Largest and Finest Assortment in the Market, Mounted and Unmounted.



A New Creation and a Winner
 In **Hat Pins**
 Gold and Platinum Effect, set with Brilliant Rhine Stones
 Various Shapes, such as Ball, Pear, etc.
 As light in weight as any other regular Hat Pin
 To retail from \$1.00 up, at a handsome profit to dealer
SUPERIOR COMB CO.
 Makers of Mounted Combs and Other Rhine Stone Novelties
 Factory and Office: 43 John St., N. Y.



(Pat. applied for.)
Balance Hole Jewels—Size of the hole numbered on setting. Saves time and duplication. You can order just what you want. If your jobber does not handle them, send to us. Made for all kinds of American movements.
Ruby and Sapphire, \$1.25 per dozen
THOS. J. JUZEK & CO., Elgin, Ill.

Cable Address: "LEOGOLDIE" N. Y.
 Telephone, 4115 Cortlandt Amsterdam, 2 Tulp St.
 Paris, 27 Rue Drouot.
LEO. GOLDSMITH
 IMPORTER OF
Diamonds and Precious Stones
 9, 11 & 13 Maiden Lane, N. Y.
 Diamonds, Rubies, Sapphires, Emeralds, Opals, Olivines, Pearls, Half-Pearls, Turquoises, Reconstructed Rubies, Reconstructed Sapphires.

Gems and Precious Stones
 Cloth, Postpaid, \$1.00
 Published by
 THE JEWELERS' CIRCULAR PUB. CO.
 11 John St., New York

Fifth Annual Dinner of the Jewelers' Bowling League of New York Proves a Great Success.

THE fifth annual dinner of the Jewelers' Bowling League of New York was held Saturday evening at the Broadway Central Hotel, New York, and was attended by members of the league and their guests to the number of nearly 200, who join in declaring it the best dinner ever given by the organization. It was a jolly affair from beginning to end, and nothing was left undone that could add to the pleasure of the evening. A spirit of good fellowship and jollity was in evidence from the commencement of the banquet until the diners dispersed.

The feast itself was excellent, and it is needless to say that the merry bowlers did it justice. The evening was enlivened by the awarding of the various prizes and by an entertaining vaudeville programme. The singing of popular songs by the members between courses also added much to the spirit of the occasion.

Before the dinner began the members met and spent a social half hour in the hotel parlors, renewing old friendships and discussing incidents of the bowling season. At about 7 p. m. the wide dining room doors swung open and the guests found their respective places at tables attractively arranged so as to afford an open space in the center of the room facing the head table, at which sat President G. S. Hemingway, Col. John L. Shepherd and other officers and members of the dinner committee.

On the table in front of the president were the two annual trophies, the silver cup which had been donated by C. F. Wood & Co.'s team after winning it the first year, and the Avery trophy, a beautiful prize made up of a gold bowling ball held up by three silver pins.

Each bowling team had a separate table, and when all were seated joined in singing "Harrigan" as the first course was being disposed of. Music was furnished by a pianist, and there were occasional vocal solos. The menu cards contained the choruses of popular songs in which all the members joined. The menu was as follows:

- Blue Points.
- Potage.
- Cream of Tomatoes.
- Hors d'Oeuvres.
- Celery. Queen Olives, Radishes.
- Poisson.
- Planked North River Shad.
- Venetian Pommes Croquettes.
- Sauterne Premiere.
- Releve.
- Filet Mignon with Mushrooms.
- Spaghetti au Gratin a la Creme.
- Pontet Canet Special.
- Punch.
- Benedictine.
- Roti.
- Stuffed Philadelphia Capon au Cresson.
- Cranberries. Baked Sweet Potatoes.
- Salade.
- Lettuce and Tomato.
- Glace.
- Neapolitan Ice Cream.
- Dessert.
- Assorted Cakes.
- Cafe Demi Tasse.
- Cigars. Cigarettes. White Rock.

With the arrival of coffee and cigars President Hemingway arose and, calling for order, said:

Gentlemen—At the end of each bowling year we

have a dinner and after the dinner it is our custom to award the prizes. This year the prizes have been well earned. There have been high individual and team bowling scores and the contest has been a good fight and very close. The teams have been more evenly matched than in previous years and there has been much interest shown in the outcome of the struggle.

To-night we are here enjoying ourselves and we have with us many members of the different clubs in the league who have seen the games of their respective teams.

He then spoke of the evening of the championship game and called upon Captain Ward, of the N. H. White & Co. team, to step forward and receive the first team prize. Wild applause greeted the appearance of Captain Ward, and in response to repeated calls for a speech he thanked the league members in a few well-chosen words.



WM. TAYLOR, JR. C. E. ROLL. N. PEARSALL. W. E. WARD. H. H. DILLINGHAM.
MEMBERS OF THE N. H. WHITE & CO. TEAM, WINNERS OF THE CHAMPIONSHIP TROPHY.

President Hemingway then gave out the other prizes to the captains of the successful teams. When the first individual average prize was awarded to C. E. Roll for the fourth year, he was greeted with a deafening storm of applause. His average this year was 196 4/60. The Avery trophy, the team strike prize, was won by the Cross & Beguelin team, which also took the second team prize. The other prizes went as follows: Third, Cooper Diamond Co., Captain Howell; fourth, C. F. Wood & Co., Captain Wood; fifth, Aikin-Lambert Co., Captain Ilgin.

The contest for individual average was close between the first four men. Those following Mr. Roll were: Second, Platt Adams, 190 18/48; third, W. G. Wood, 184 50/51; fourth, E. G. Howell, 182 35/60; fifth, W. C. Weber, 182 24/59; sixth, F. Schaller, 178 43/45; seventh, O. N. Windorf, 176 26/60.

Appropriate cash prizes were also award-

ed to other winners as follows: First credit prize (percentage), F. Schneider, 810 10/56; second credit prize, E. E. Wood, 806; third credit prize, R. H. Woodrow, 788 1/3. The first individual high score, G. H. Ertel, 266; second, L. A. Goettler, 265. Tiffany & Co. won the team high score prize with a score of 994.

After the awarding of the prizes President Hemingway rose and spoke of the dinner committee and their excellent management of the dinner, and extended to them a vote of thanks on behalf of the league. The committee was composed of H. Laboureur, J. F. Schierloh, A. C. Capouilliez and R. H. Woodrow.

The president then called on Colonel Shepherd as the speaker of the evening. "I do not like the way your president introduced me, as your old friend," said Colonel Shepherd. "I am as young as any of you in spirit, if not in years. I am not going to keep you long, as

I understand your committee has a fine programme waiting." As usual, Colonel Shepherd had a fund of stories to draw from, and told an amusing one of a gentleman who delivered a temperance lecture. He wound up by giving the members some good advice on the subject of the elements that make for success in business, ending by reading a clever poem of his own on the subject of "Opportunity." He was roundly applauded at the conclusion of his address.

An entertainment was then given on a platform at one side of the dining room. J. J. Armstrong, who sang several songs between courses, was in charge of the programme. The talent included: Nellie Lytten, singing comedienne; Miss Jennette Deval, specialty artist. Miss Mabel Bennett, character comedienne; John J. O'Donnell, the "Little" man who says things, and Harry Cowman, pianist.

The photograph of the winning team is produced herewith. The individual scores

MONTANA SAPPHIRES

AT ATTRACTIVE PRICES

Where uniformity of size, evenness of color and quality are essential, our stock of Montana Sapphires particularly commends itself.

Pearls and practically every precious and semi-precious stone but the diamond.

BUY FROM THE CUTTERS

AMERICAN GEM & PEARL COMPANY

14 & 16 CHURCH STREET, NEW YORK

London, 16 Holborn Viaduct

Paris, 39 Rue de Chateaudun

FROM MINES TO MARKET

for the game which decided the championship were as follows:

N. H. White & Co.—Pearsall, 155; Dillingham, 236; Peck, 133; Ward, 203; Roll, 208; total, 935.

Cross & Beguelin.—Schneider, 173; Scott, 170; Windorf, 188; Ertel, 159; Woodrow, 151; total, 841.

Echoes of the Banquet.

Charlie Brinck came late.

"Dunk" Stewart can dance all right.

Most everybody there was a "good old soul."

The souvenirs were dainty metal cigar lighters.

President Hemingway presided with much dignity.

Col. Shepherd was as entertaining as ever His speech was much enjoyed.

Among those present were: Col. J. L. Shepherd, G. S. Hemingway, A. C. Capouilliez, W. K. Scaley, J. G. Hughes, O. F. Green, A. Paulcheck, J. F. Schierloh, H. Labouseur, J. S. Humbert, F. W. Ketcham, W. J. Cochran, Hardy Bush, R. C. Richter, R. H. Smith, A. D. Haring, R. B. Haring, F. W. Trewin, P. C. Malone, H. A. Flinn, A. L. Nichols, C. F. Brinck, A. Beucke, N. D. Streeter, G. Meiners, Jr., F. S. Neeley, Harry Magnus, Hawley Stone, Paul Reichhelm, G. B. Spaulding, Robert Linen, W. R. Gardner, S. G. Hardie, Charles Layng, H. F. Myer, Louis W. Tompkins, J. H. Hunter, A. W. Fraser, R. L. Knickenhauer, W. C. Theber, A. Hollnde, H. Knoepfle, Edw. McGaffney, Edward Howell, C. E. Roll, A. H. Peal, F. S. Eason, G. V. Hane, L. Weigel, H. H. Dillingham, G. L. Dillingham, W. Taylor, Jr., A. Velsor, W. Young, W. A. Thompson, F. W. Howell, W. J. Finnegan, A. L. Phillips, D. D. S. Polhemus, W. L. Ward, W. E. Ward, C. W. Smaller, W. E. Hense, A. Seider, G. A. Taylor, N. Pearsall, W. Dickie, F. Rathbone, J. Labouseur, J. Hall, C. P. Jennings, E. Church, J. B. Sanford, George S. Semple, P. Rocchietti, J. H. Eggens, Jr., A. E. Cocks, S. C. Wakefield, A. J. Murphy, D. H. Stewart, A. A. Tickell, C. O. Deakin, J. A. Bowie, J. N. Clinch, J. Obermayer, P. J. Breivogel, F. D. Ilgen, L. B. Mann, C. P. Elliot, J. Behrens, E. Atzert, C. P. Holker, J. A. Phillips, F. Reast, F. Regenhard, M. N. Roe, J. Ruthig, C. J. Nickerson, F. Schneider, C. Stanley, H. Kip, L. Leronier, C. Leronier, M. Ilvey, J. Kerk, E. P. Washbron, G. Carmichael, G. Frey, J. Kramer, P. J. Cofey, A. Briggs, E. Knapp, A. Poltock, J. Ertel, H. Williams, G. Ertel, E. Valle, J. Donnelly, O. Windorf, F. Sulzherger, S. Schoonmacher, C. W. Koehler, W. Peer, W. Penfold, F. Keller, A. Winters, A. Poole, C. Parker, C. Horn, W. Schaefer, J. Scott, W. Peckham, I. Wiltshire, B. Budlong, W. Hallam, George Heisinger, J. R. Hudson, W. F. Daboll, W. D. Hildebrand, C. Willemmin, W. Fuller, W. I. Ferris, R. C. Liddell, W. Forshaw, J. C. Thorburn, F. E. Fluehr, H. V. Terhune, R. C. Wiggins, W. Hammond, M. O'Connell, W. H. Kernan, W. Rogers, W. Armstrong, John Labouseur, John Hall, Erie Church, G. Greisel, M. Cook, W. L. Stone, E. W. Brinkman, Stanley Jones, W. A. Moore, George Graff, H. R. Brinkman, C. M. Newins, G. Reebhausen, Dave Hannigan.

CROSSMAN COMPANY

BAROQUE PEARL BAR PINS

3 Maiden Lane, New York

A. ROSEMAN, 9-11-13 Maiden Lane, New York

IMPORTER OF

DIAMONDS

Maker of Diamond Jewelry



TRADE-MARK.

Established 1872

HEADQUARTERS FOR

**AMERICAN
WATCHES**

William G. Morstrom & Co.

DIAMOND IMPORTERS and MANUFACTURING JEWELERS

Memorandum Packages of Loose or Mounted Stones on request. We solicit Special Order Work.

78-80 STATE STREET

CHICAGO, ILL.

Death of Harvey S. Mark.

INDIANAPOLIS, Ind., April 3.—Following a short illness, Harvey S. Mark, a well-known jeweler, died at his home in Marion, yesterday. Mr. Mark was 70 years old, and in 1856 founded the first jewelry and watch store in Marion.

During the Civil War the deceased served with an Indiana regiment as a musician, being leader of a regimental band. Although he was never married he reared two children of a deceased brother, who are the nearest relatives surviving.

D. Elmquist will shortly occupy the store room being completed by A. N. Lewis near the post-office building, at Willmar, Minn.

Involuntary Bankruptcy Petition Filed Against F. G. Happel & Co., Chicago.

CHICAGO, April 4.—An involuntary petition in bankruptcy was filed here last Thursday against F. C. Happel & Co., wholesale jewelers at 88 State St. The petitioning creditors and the amounts due them are: R. F. Simmons & Co., \$5,228; Parks Bros. & Rogers, \$879, and the Fontneau & Cook Co., \$1,870. The petitioners allege that the concern, while insolvent, committed an act of bankruptcy by paying certain creditors with a view to preferring them over others. The affairs of Happel have not been in good shape for some time.

On March 20 the firm placed its affairs in the hands of the Jewelers' Board of Trade and asked a settlement at 50 per cent. on time. This was declined. A question of long extension was then abandoned. An agreement was formulated whereby Mr. Happel was to give indorsed notes covering the gross amount of each payment, the proceeds to be distributed monthly by a trustee. The following was the plan recommended: All claims of \$50 and less to be paid in full by May 15, 1908. All claims over \$50 and less than \$100, one-half to be paid June 15, 1908, and the balance to be paid by July 15, 1908. All other creditors were to receive 50 per cent. of their claims in equal parts on May 15, June 15, July 15, Aug. 15, Sept. 15, Oct. 15, Nov. 15 and Dec. 15, 1908. The firm submitted the following statement:

Accounts receivable.....	\$15,606.81	
Not collectible	13,396.88	
	\$32,209.93	
Less five per cent. discount...	1,610.49	\$30,599.44
Stock on hand.....	\$69,781.72	
Less 20 per cent. for old stock.	13,956.34	55,825.38
Cash	1,288.47	
Furniture	500.00	
Jewelers' Fund.....	700.00	
		\$88,913.29
Total assets.....		59,894.33
Due creditors.....		\$29,018.96
Surplus		

This statement, showing a surplus of nearly \$30,000, was thought to warrant a better settlement than 50 cents on the dollar which Happel offered. Creditors said they thought that 75 cents would be a just compromise. Happel refused this and the bankruptcy proceedings followed. Everett I. Parks is here now and it is believed that a compromise soon will be effected.

In the meantime Wm. F. Zibell has been appointed by the court, temporary receiver, under a bond of \$30,000.

The following is the list of creditors: Less than \$50—A. C. Becken Co., Hipp. Didisheim & Bro., Seth Thomas Clock Co., Otto Young & Co., Jules Racine & Co., E. J. Koch & Co., Western Clock Mfg. Co., Despres, Bridges & Noel, Western Watch Case Co., Martin, Copeland & Co., Ostby & Barton Co., W. J. Feeley Co., Hold-On Clutch Co., F. & F. Felger, G. Fox & Co. From \$50 to \$100—Fowler Bros. & Co., Electric Chain Co., Benj. Allen & Co., Wm. L. Gilbert Clock Co., International Silver Co.

From \$100 to \$150—E. A. Potter Co., J. T. Inman Co., Swartzchild & Co., Ansonia Clock Co.

From \$150 to \$200—Fletcher, Burrows & Co., R. L. Moorehead & Co., Maintien Bros.

& Elliott, Chas. F. Wood & Co., Waterbury Clock Co.

From \$200 to \$250—R. L. Griffith & Son Co., Harvey & Otis, Barden & Hull, W. H. Bell & Co., J. H. Peckham Co., Furbish, Swift & Fisher.

From \$250 to \$300—C. E. Hancock Co., Ford & Carpenter, Jeannette Jewelry Co., C. H. Cook Co., Bugbee & Niles Co., H. H. Curtis Co., F. Blauer & Co.

From \$300 to \$350—B. A. Ballou & Co., S. Buchsbaum & Co.

From \$350 to \$400—Sturtevant, Whiting & Bigelow, W. E. Hayward, Miller, Fuller & Whiting, Leach & Miller, G. O. Sweet & Son Co., Robbins & Appleton.

From \$400 to \$500—Warren & Williams, G. I. Vose Mfg. Co., Bliss Bros. Co., Smith & Crosby, Stern Bros. & Co., Emrich, King & Schorsch, R. Wallace & Sons Mfg. Co.

The largest creditors are: S. K. Merrill & Co., \$833; A. A. Greene & Co., \$1,535; Payton & Kelley Co., \$541; Manchester Mfg. Co., \$885; Thornton Bros. Co., \$886; Parks Bros. & Rogers, \$867; Potter & Buffinton Co., \$1,481; Providence Stock Co., \$659; Edwin Lowe Co., \$1,111; R. F. Simmons Co., \$1,705; Geo. L. Brown & Co., \$1,328; C. A. Marsh & Co., \$1,635; T. G. Frothingham & Co.; E. D. Gilmore Co., \$939; G. C. Hudson Co., \$546; Bates & Bacon, \$1,381; W. G. Clark & Co., \$1,527; S. O. Bigney & Co., \$3,326; Fontneau & Cook Co., \$1,828; J. J. Sommer & Co., \$1,120; Sykes & Strandberg, \$704; Bliss Bros. Co., \$1,243; Seofield, Melcher & Seofield, \$2,017; Plainville Stock Co., \$773; Joseph Fahys & Co., \$1,731; Hirsch & Flashner, \$2,040; Dueber Watch Case Mfg. Co., \$1,942; Hampden Watch Co., \$2,237; Hamilton Watch Co., \$3,354; Crescent Watch Case Co., \$1,513; Elgin National Watch Co., \$617; W. S. Sparrow, \$759. There was also due March 20 the following items to employes: A. Wedeking, \$200; A. E. Happel, \$152; C. P. Smith, \$100; C. H. Hanson, \$100; W. H. Osmun, \$306.

Maurice Dreshfield Examined in Bankruptcy Proceedings as to Diamonds He Obtained from R. A. Breidenbach.

At a hearing in involuntary bankruptcy proceedings before United States Commissioner Alexander in New York last Friday, Maurice C. Dreshfield, who was associated with George H. Carpenter in transactions by which diamonds valued at \$182,549 are alleged to have been obtained from R. A. Breidenbach, 51 Maiden Lane, New York, was examined at some length by Attorney William Lesser, the receiver in bankruptcy.

Mr. Dreshfield told of an arrangement he entered into with Carpenter. He said that he was introduced to Carpenter by Charles Barry and O. C. Ticer, and that Barry told him that Carpenter, who was at the head of the Monarch corporation, needed \$300,000 for the plant in Bridgeport, Conn., for which Carpenter would give as security notes and other paper. He said an agreement was entered into between himself and Carpenter which was canceled and a second one drawn up, under which the diamonds were obtained from Mr. Breidenbach.

He testified that he started to buy goods Sept. 3, 1907, the day on which the agree-

ment was signed. He was questioned about a statement which was given him by Mr. Carpenter, and said that he obtained the statement at the request of Mr. Breidenbach.

It is claimed that between Sept. 9, 1907, and Dec. 30, 1907, diamonds valued at \$182,549 were obtained from Mr. Breidenbach on which only \$9,445 was paid.

The demurrer to the petition in bankruptcy filed against Maurice C. Dreshfield has been denied by Judge Holt. Mr. Dittenhoefer, the attorney representing Carpenter, stated in court that he wished to retire as attorney for Mr. Dreshfield.

Death of Louis H. Davis.

Louis H. Davis, of the diamond importing firm of B. H. Davis & Co., 71 Nassau St., New York, died Tuesday evening, March 31, at his late residence, The Manhasset, 300 W. 109th St., New York. His death resulted from a complication of diseases.

Mr. Davis, who was widely known in the



THE LATE LOUIS H. DAVIS.

diamond trade of this country, was born in New York, Sept. 6, 1854, where he spent his early life and obtained his education. He turned his attention to the jewelry business, and in 1885 became a member of the firm, which business his brother, B. H. Davis, had founded in 1877, and the business was continued by the deceased and his brother, under the style of B. H. Davis & Co.

Mr. Davis traveled extensively and often visited Carlsbad, Germany, where the accompanying photograph was taken in July, 1907. He was a member of several charitable organizations and is survived by a widow and one son.

The funeral was held from the late residence of the deceased, Friday morning.

The output of ruby, sapphire and spinel, reported by the Burma Ruby Mines Co. during the year ended Feb. 28, 1907, was 326,855 carats, valued at \$477,700, against a value of \$441,700 returned for the previous year. Of the total value, \$465,115 is due to the rubies obtained. The average number of workers during 1906 was 2,367.

Goodfriend Bros.

IMPORTERS OF PEARLS

Sapphires
Rubies
Opals
Emeralds

Aquamarines
Peridot
Gem Coral
Tourmalines

and OTHER
Precious and Imitation Stones

PARIS:
10 Rue Cadet.
PROVIDENCE:
212 Union St.

PEARL-OPAL-CORAL
& AGATE NECKLACES

9-11-13
Maiden Lane
NEW YORK

Geo. Brunswick, N.Y.

Temporary Receiver Appointed for the Business of Parker, Kolb & Co., Bridgeport, Conn.

BRIDGEPORT, Conn., April 4.—An application was made to Judge George W. Wheeler at the court house this morning for the appointment of a temporary receiver for Parker, Kolb & Co., jewelers in the Arcade. After the hearing of counsel for the creditors and the company, Judge Wheeler appointed Edward W. Button as temporary receiver, under bonds of \$25,000. The time for confirmation of his appointment, which is to run for at least two months, was fixed for Monday, April 3.

The application for the receiver was made by Gould & Gould acting for about 80 per cent. of the creditors, including the Gorham Co., Wm. L. Gilbert Clock Co., and Abraham Roseman, all of New York. According to a statement made by Judge Wheeler the concern's assets largely exceed the liabilities. The assets, which include stock and a small amount of cash, amount to about \$17,000, while the liabilities are about \$11,000. There is no allegation of questionable proceedings or of any intention to defraud creditors.

In making the petition for the appointment of a receiver, the creditors simply believe that their united interests will be more fully protected. The company will have an opportunity to oppose the confirmation at the hearing which will take place on Monday, April 13, if the directors think it advisable. Any creditor who feels aggrieved may also appear and oppose the confirmation.

Fire in Omaha, Nebr., Does Considerable Damage to Jewelry Stocks.

OMAHA, Nebr., April 3.—Fire started early yesterday morning from an unknown cause and damaged the Bushman block, at the northeast corner of 16th and Douglas Sts., to the extent of \$4,000 and caused damage to stocks of business and professional firms in the building by smoke and water amounting to \$40,000. Of these the jewelry firms of T. L. Combs & Co., located on the south side of the building, and Fred Brodegaard & Co., on the west side, sustained the largest losses.

The fire was hard to handle owing to the nature of the building, which is old and yielded readily to the flames. No damage was done to the stocks in the stores on the first floor by fire, but the stocks of jewelry, etc., were damaged by smoke and water.

The loss sustained by T. L. Combs & Co. is \$10,000. Water and smoke filled every portion of their store, damaging the entire contents. Even drawers in which were kept fancy articles of glass and silverware were filled with muddy water. The fixtures also were ruined, and the interior of the show cases were filled with water.

The store of Fred Brodegaard & Co. suffered a loss of \$5,000, mud, water and smoke doing the greater part of the damage. Fortunately the losses of these two firms are fully covered by insurance.

It was at first thought that Samuel N. Lindsay, whose store is in the same building, had suffered a loss, but it was a false report, no stock whatever having been injured. Another fire occurred in the store of Fred. Brodegaard & Co., one year ago

CORAL

All Kinds of Coral
Specialties for Jewelers

**DROPS
BUTTONS
LENTILLES**

**CORAL
NECK-
LACES**

All Shades
and Sizes

Graduated and
Uniform

CORAL

**Extra Rose
CORAL
A Specialty**

Gold Medal
St. Louis, 1904

Grand Prix
Liege, 1905

CORAL MANUFACTURING COMPANY

BORRELLI & VITELLI

3 Via Amedeo,
Terre del Greco Italy

401 Broadway, New York
Telephone, 5412 Franklin

19 Rue d'Hauteville,
Paris, France

LOUIS FELDENHEIMER

Importer and Cutter of

PRECIOUS STONES AND PEARLS

41 MAIDEN LANE
NEW YORK

Association Notes.

What Is Being Done by the State Organizations of the Retail Jewelers.

As already announced, the executive committee of the Missouri Society of Retail Jewelers, consisting of R. D. Worrell, president, Mexico; Claud M. Wheeler, Columbia; G. E. Read, Lebanon; W. H. Meyer, Lawson; Chas. H. Bard, Sedalia; H. L. Raines, Maryville; C. E. Ticman, California; Adam A. Hafner, DeSoto; Otto Buder, St. Louis, and C. E. Range, Trenton, met at Kansas City, Mo., March 23, and formulated plans for the next State jewelers' meeting to be held in that city June 9, 10 and 11. A great deal of enthusiasm was shown by the members and in the afternoon a committee from the Kansas City Jobbers' Association was present and offered to assist the committee in any way possible to make it the most successful convention ever held by the jewelers. Arrangements are being made with the Missouri Association of Opticians to have a joint meeting, thus assuring a large attendance. The committee are also in correspondence with the jewelers and opticians of Kansas, and will try and induce them to come to Kansas City for their State meeting, and no doubt this will be effected, for in union there is strength, and the west has the organization movement at heart.

* * *

Des Moines has been chosen as the convention city for the Iowa State Association of Opticians and the Iowa Retail Jewelers' Association, which will hold joint sessions during the days of June 23, 24, 25 and 26. Headquarters have been selected at the Savery. The opticians' convention, which will occupy the last two days of the period, will be turned over largely to the framing of a bill for the consideration of the next general assembly calling for the registration and State control of opticians throughout the State. The officers are: A. F. Thompson, Adel, president; B. M. Bills, Vinton, vice-president; George J. Feige, Des Moines, secretary. The retail jewelers will have their convention features by large exhibits of cut glass, metal goods and all kinds of jewelers' supplies. The officers are: President, Mack A. Hurlbut, Fort Dodge, Ia.; vice-president, A. W. Carpenter, Burlington, Ia.; secretary-treasurer, N. Nielson, Harlan, Ia.

* * *

The executive committee of the North Dakota Retail Jewelers' Association, at a meeting at Leeds, N. Dak., recently, decided to hold the second annual meeting of the association at Jamestown. This will take place June 16 and 17, and the secretary and treasurer, C. E. Tilton, is now at work preparing a programme.

* * *

Charles E. Baab, Parkersburg, W. Va., secretary of the West Virginia Retail Jewelers' Association, has sent out a notice to the jewelers of that city urging their presence at the third annual meeting to be held at the Waldo Hotel, Clarksburg, W. Va., Wednesday, April 22, at 2 p. m. The association has promised that speakers of national reputation will attend and there are a number of other features in the programme which, it is expected, will interest

every jeweler who participates in the proceedings.

* * *

C. C. Stevenson, Pittsburg, Kans., who is secretary and treasurer of the Kansas City Retail Jewelers' Association, has sent out notices to all the members, calling their attention to the fact that the annual meeting will be held June 9, 10 and 11, at Kansas City, at the special request of the jewelry and optical association of that city, which entertained the State association during the past two years. Every effort is being made to have a large attendance.

Bids Received and Contracts Awarded by Government Departments to Supply Various Articles.

WASHINGTON, D. C., April 1.—The District Commissioners are calling for proposals until April 15 for the following items:

20 Ansonia clocks, regulator C; height, 32 inches; dial, 12 inches; eight-day; to be placed in position in building and guaranteed for two years.

15 Seth Thomas clocks, regulator No. 2, in oak case, to be placed in position in building and be guaranteed for two years.

50 Seth Thomas clocks, 30-hour, "Echo."
10 Sets knives and forks, carving, game, No. 1246 Meriden cutlery or equal, sample required.

50 After dinner coffee spoons, silver plated, extra heavy, A1, Wallace Bros., shell pattern, stamped "Public Schools."

Two dozen spoons, dessert, silver, A1, plated.

50 Spoons, dessert, silver plated, extra heavy tipped, R. & B. ware.

50 Spoons, table, ditto.

Six dozen spoons, tea, silver, A1, plated.

50 Spoons, tea, silver plated, extra heavy tipped, R. & B. ware.

WASHINGTON, D. C., April 2.—The Navy Department has awarded the contract for a quantity of silverware for the Brooklyn Navy Yard to the International Silver Co., of Meriden, the only bidder, at \$1,884.

WASHINGTON, D. C., April 2.—The District Commissioners have received the following bids for the installation of an electric clock system in the new municipal building in this city: Magneta Co., Washington, D. C., \$1,696, and \$19 for the installation of all additional clocks; A. O. Hutterly, Washington, D. C., \$1,580; M. Duperow, Washington, D. C., \$1,350; Standard Electric Time Co., New York City, \$1,299; Self-Winding Clock Co., Brooklyn, N. Y., \$1,211.

WASHINGTON, D. C., April 3.—The following bids for thermometers have been received by the Bureau of Supplies and Accounts, Navy Department:

For one outfit resistance thermometers—Leeds & Northrup Co., Philadelphia, Pa., \$203; Manning, Maxwell & Moore, New York, N. Y., \$213.15; Taylor Instrument Co., New York, N. Y., \$288; Vermilye & Power, New York, \$213; Western Electric Co., New York, \$213.

For 45 thermometers and 36 sockets for same—Central Metal & Supply Co., Baltimore, Md., \$135; H. F. Green, Brooklyn, N. Y., \$231; Hohman & Maurer, New York,

\$240.90; Manning, Maxwell & Moore, \$204.30; National Electrical Supply Co., Washington, D. C., \$304.50; Philadelphia Thermometer Co., Philadelphia, Pa., \$189.90; Randall-Faishner Co., Boston, Mass., \$167; J. B. Roach, Brooklyn, N. Y., \$240.83; Chas. J. Tagliabue Mfg. Co., New York, 189.50; Vermilye & Power, New York, \$134.66; Western Electric Co., \$198.56.

Bids have been opened for the Isthmian Canal Commission for the purchase of 24 thermometers, as follows: Manning, Maxwell & Moore, \$33.60, \$19.20 and \$27.60, delivery 45 days; F. T. Whitte Hardware Co., \$15.12, \$52.92, \$25.20, \$30.24 and \$50.40, delivery 15 days.

WASHINGTON, D. C., April 4.—The United States Life Saving Service is calling for proposals until April 28 for the following supplies for the fiscal year ending June 30, 1908: 18 carving forks, Russell's, Northampton Cutlery Co.'s, Landers, Frary & Clark's, or equal; 242 dinner forks, best shear steel, or equal; 28 carving knives, best shear steel, 12-inch blade, same as above; 416 dinner knives, best shear steel, same as above; 46 dozen table spoons, pure white German silver, not less than 18 per cent. nickel, 8 1/16 inches, 20 ounces to dozen; 53 dozen teaspoons, same, 5 11/16 inches, 9 5/32 ounces to dozen; 34 barometers, Lifebuoy, aneroid, first quality, in bronze cases; 87 leather cases for Imhauser's time detectors; marine clocks, eight-day, seven-jewel, lever escapement; 10 compasses, liquid, boat, complete; 10 binocular glasses, 26-inch, field, short body; oxidized slides, heavy sole leather cases; 20 telescopes, 22-inch, day and night adjustment; Imhauser's watchman's time detectors, latest improved, safety lock attachment, leather case; Newman's watchman's time detectors, latest improved, graduated to 24 hours, leather case, dial plates, etc., complete; Hahn's watchman's time detectors, latest improved, complete, leather case; Kopp's latest improved "Official Fire Insurance Record" time detectors, complete.

WASHINGTON, D. C., April 4.—The Commissioner of Indian Affairs is inviting proposals until May 7 for 92 eight-day clocks, pendulum or spring lever.

Jewelers' Gold Bars Withdrawn and Exchanged at New York.

Week Ended April 4, 1908.

The U. S. Assay Office reports:
Gold bars exchanged for gold coin.....\$221,885.02
Gold bars paid depositors..... 38,848.57

Total\$260,713.59
Of this the gold bars exchanged for gold coin are reported as follows:
March 30.....\$52,204.32
" 31..... 20,524.62
April 1..... 47,278.72
" 2..... 61,206.05
" 3..... 35,596.14
" 4..... 15,085.17
Total\$221,895.02

Reed & Co. began an auction sale at their store, 204 Main St., Greensburg, Pa., Saturday, March 28, which has continued daily, afternoon and evenings. The sale, which includes the entire stock of watches, clocks, jewelry, silverware, cut glass, umbrellas, etc., is for the purpose of reducing stock.

EICHBERG & CO.,

IMPORTERS AND CUTTERS OF

DIAMONDS,

65 NASSAU STREET, (Prescott Building.) NEW YORK.

HIMALAYA MINING COMPANY

MINERS AND CUTTERS OF
PRECIOUS AND SEMI-PRECIOUS STONES

537 FIFTH AVENUE
NEW YORK

LONDON
PARIS

OSBERSTEIN
PROVIDENCE



H. Lichenstein has opened a new store in Coatesville, Pa.

W. J. Mulnix is opening a jewelry store in King City, Mo.

J. A. Howard contemplates opening a new store in San Antonio, Tex.

Fraser & Gamm have opened a new jewelry store in Leavenworth, Kans.

Martin J. Reddy has established himself in the jewelry business in Medford, Ore.

The Curry Optical Co. has engaged in business at 1318 Second Ave., Seattle, Wash.

W. A. Wilson & Co. have engaged in the wholesale jewelry business in Vancouver, B. C.

Chas. Jussek has just engaged in the retail jewelry business at 137 E. King St. Lancaster, Pa.

J. E. Russell. Los Angeles, Cal. has started a watchmaking and jewelry business in Corona, Cal.

J. L. Foote, who has had many years' experience in the jewelry business, has located at Fullerton, Cal.

Mr. Brown, formerly of Birmingham, Ala., has moved to Dothan, Ala., where he contemplates engaging in the retail jewelry business.

George W. Jacobson will open a jewelry store in the premises formerly occupied by M. Rosenbaum, at 316 N. 8th St., Philadelphia, Pa., about April 15.

H. B. Benedict, Cherokee, Ia., and W. L. Wilkinson, Denison, Ia., will open a jewelry store the latter part of this month at 227 S. Phillips St., Sioux Falls, S. Dak.

Peter Moeller, for several years in the employ of Chas. R. Hoffman, a jeweler at Waupaca, Wis., will open a store about June 1, on his own account.

The Wisconsin Pearl Button Co. has been incorporated at La Crosse, Wis., with a capital stock of \$75,000. The incorporators are: Henry and Emma Hallauer and Carl Rau.

G. Hallauer, formerly with Gurney & Ware, Kansas City, Mo., has engaged in the watch repairing business for himself, having secured a location at 518 Altman building, where he will do work for the trade.

The Spivey-Moore Jewelry Co. is the name of a new concern which has been incorporated with a capital stock of \$15,000 in Birmingham, Ala., to engage in the general jewelry business. The concern proposes to begin business with \$8,100. The officers are: President, C. E. Moore; vice-president, L. P. Spivey; treasurer, L. S. Moore.

Thieves recently made an unsuccessful attempt to break into the retail jewelry store of A. T. Judson, Ashley, Pa. The intruders were apprehended in the attempt by Mr. Judson himself, who pursued them for a short distance at the point of his revolver. They escaped over the Central railroad tracks.

VARISCITE SOHN & HYMAN

The Newest Stone for High Class Jewelry 47-49 MAIDEN LANE NEW YORK

The "SECURITY" Necklace Clasp

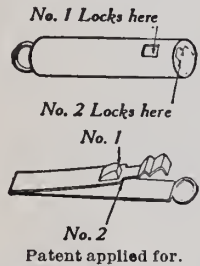

HEAR IT SNAP
Absolutely Secure and Simple. Cannot Pull Out
LOCKS IN TWO PLACES
Making it Doubly Secure
The Only Perfect Clasp

Ask Your Jobber or Write.

PRICES TO THE TRADE:

No. 1	No. 1.	10-Karat,	- - -	\$6.00 doz.
	1-B.	10	- - -	7.00 "
No. 2	1.	14	- - -	7.00 "
	1-B.	14	- - -	9.00 "
No. 1B	1.	Platinum,	- - -	18.00 "
	1-B.	Gold Filled,	- - -	2.00 "
No. 2	1.	"	- - -	2.25 "
	1.	Sterling Silver,	- - -	2.00 "

The Hoffman Novelty Co., Makers, 79-83 No. Pearl St., ALBANY, N. Y.

"CLINCH"



Safety Catch for Scarf Pins

Does not mar the pin. Nothing to get out of order. Simple and neat.

One turn to the right grips like a vise.

..FITS ANY SIZE PIN..

PRICES TO THE TRADE

No. 1	Gold Plated	\$1.50 doz.
No. 2	Roman Gold	2.00 doz.
No. 2	14k G'd Pl'to	2.25 doz.

No. 1, 25c.

It's the Little Things that count.

The dainty little things that appeal at once to the casual observer. If it's useful, as well as ornamental, so much the better. Here is a LITTLE THING, so very useful and so pretty in design and finish, that you have but to show one to make a sale, and it yields a BIG PROFIT. It is called

The Automatic Eye-Glass Holder

Can be used as well for a Pencil Holder. It is made in Enamel, Gold, Silver and Rolled Plate, in a variety of artistic designs. We fully guarantee every Holder. We mean it, and will replace any Holder that fails to satisfy. Samples sent upon request. Send for catalogue.

Est. 1832 **Ketcham & McDougall, Manufacturers**

37-39 MAIDEN LANE, NEW YORK

ALSO MAKERS OF THE LEADING LINE OF THIMBLES.



Shipments of Watches, Clocks, Jewelry and Plated Ware to Alaska, Hawaii, Porto Rico and the Philippines.

WASHINGTON, D. C., April 6.—Figures as to the trade of the non-contiguous territories of the United States during the month of January show that our exports of clocks and watches to Alaska are steadily, if somewhat slowly increasing. During the month the value of the exports of clocks was \$594, as compared with \$194 for the corresponding month in 1907. For the seven months the showing is not quite so satisfactory, as it was only \$1,302, as compared with \$4,712 for the corresponding seven months in 1907. The trade in watches is very slight, still there was an increase in value for the month from \$22 to \$27, and for the seven months from \$514 to \$552.

There seems to be quite a decided falling off in the value of the exports of jewelry, which for the month was valued at \$5,980, as compared with that of \$9,982 in 1907, and for the seven months there was a decline noted from \$56,514 to \$54,702, although the trade is still far in excess of the \$38,644 reported for the first seven months of the year 1905-6. In all other manufactures of gold and silver, what trade we had is fast leaving us. In January of last year the value was \$784, and this year none; while from the seven months there has been a decrease from \$3,505 to \$596.

While there is a decline in the imports of plated ware from the United States for the month, as compared with that in 1907, from \$1,788 to \$570, this is more than offset by the increase shown for the seven months, for which the value in 1906 was \$5,305, in 1907 \$9,593 and in 1908 \$11,546.

Our clock and watch trade with Hawaii shows a marked falling off. During the month we exported to that country clocks to the value of \$1,237, as compared with \$2,909 in 1907, and for the seven months there was a decrease from \$11,261 to \$10,893. In January of 1907 we exported American watches to Hawaii to the value of \$321, and during the seven months to \$2,431; during the month of January last we exported none, and for the seven months the value has been reduced to \$300.

On the other hand, the exports of American jewelry to Hawaii are in a far more satisfactory condition than they were one year ago. During January last year we only shipped to the value of \$208, and for the seven months \$1,768, while during January last the value was \$1,000, and for the seven months \$10,139; this is very encouraging, though still far behind the \$79,799 for the first seven months of 1906. There were no exports of other manufactures of old and silver during the month, but for the seven months there has been an increase in the value from \$33 to \$9,535.

Our exports of plated ware to that country are in a very unsatisfactory condition. In January of last year we shipped them \$3,434; this year, none. For the seven months there is a steady decline from a value of \$22,875 in 1906 to \$12,542 in 1907, and still further to \$9,656 during the past seven months.

Even to Porto Rico, where we were making such marked advances we find that there has been a decrease in the value of

our exports. In the matter of clocks there has been a decrease for the month from \$501 to \$375, and for the seven months from \$7,285 to \$4,655. In watches it is a little more satisfactory, as there has been a slight increase for the seven months from \$2,603 to \$2,959, although for the month there is a small decrease from \$190 to \$140.

There was even a more marked falling off in our exports of jewelry for the month from \$1,820 to \$361, but there is still an increase for the seven months from \$6,755 to \$9,823. Of all other manufactures of gold and silver no exports were noted during the month, and for the seven months there has been a decrease from \$3,057 to \$790.

Plated ware shows a slightly increased activity, the value for the month having increased from \$610 to \$677, and for the seven months from \$7,031 to \$11,310.

The trade in American watches in the Philippines, while still not very large, is showing an increase, as evidenced by the fact that the returns for January were \$386 as against \$271 last year, and for the seven months there has been an increase from \$1,990 to \$2,737. Our watch trade also shows signs of improvement. In 1907, for the seven months, it was \$411, and this year \$426. During the month of January we shipped to the islands \$188 worth of American watches, as against none in 1907.

The trade in American jewelry is also growing in the Philippines. During the month we shipped them \$199 as against \$30 in 1907, and for the seven months there has been an increase from \$608 to \$925. On the other hand, of all other manufactures of gold and silver, there has been a decrease for the seven months from \$3,645 to \$600.

The trade in American plated ware in the Philippines remains at about a standstill.

Cables and Letters Received by Antwerp Merchants as to Stability of the Diamond Market.

ANTWERP, March 25.—After some premature notes published by the European newspapers, concerning the breaking off of the negotiations between the Premier Diamond Mining Co. and the Syndicate, the following cable from the Reuter's Agency arrived on the 18th inst., and was immediately known on our market:

"JOHANNESBURG, March 18.—The Premier Mine advises that the Syndicate refuses to renew the option mentioned in the primitive agreement. Consequently the Premier Mine is compelled to enter new agreements for the sale of diamonds, but it appears from the declarations made by the president at the last yearly meeting that it is not likely that the market will be overrun with goods, neither will the prices of diamonds be reduced. REUTER."

That cable having an official appearance, one of the most important diamond cutting concerns in this city decided to write to both above companies, the DeBeers and Premier, asking for some official confirmation, and they received the following cables and letters from the secretaries of the De Beers and of the Premier Diamond Mining Co., and from Mr. Busch, director of the latter company:

(Cable.)

LONDON, March 18, 1908.

DE BEERS COMPANY INTENDS CONTINUING WORK-

ING IN AGREEMENT WITH SYNDICATE FOR THE PURPOSE OF MAINTAINING PRICES.
TYMMS, SECRETARY DEBEERS, LONDON.

LONDON, March 20, 1908.

Dear Sirs—I have been instructed to acknowledge the receipt of your letter of 19th inst. and in reply beg to again inform you that this company HAS NOT THE SLIGHTEST INTENTION TO FORCE THE SALE OR TO LOWER THE PRICE OF DIAMONDS. My committee trusts this communication will enable you to reassure your friends in Antwerp and Amsterdam, for whose state of mind (according to your letter) there is no justification whatsoever. Yours faithfully,
(Signed)

LONDON SECRETARY PREMIER DIAMOND MINING CO.

LONDON, March 20, 1908.

Dear Sirs—I beg to acknowledge receipt of your favor of yesterday's date contents of which I have noted with thanks. I am very sorry to hear that the news printed by the newspapers, that negotiations between my company and the Syndicate were broken off, had such a disastrous effect on your market, but I am quite sure that this only will be temporary because the SYNDICATE AND THE DEBEERS CO. AS WELL AS MY COMPANY ARE DETERMINED TO KEEP UP THE PRESENT STANDARD OF PRICES. As soon as my company will show goods again, which cannot be before June next, the belief that prices will be lower will quickly be dispersed. I am, dear sirs, yours faithfully,
(Signed) W. BUSCH.

After such declarations there is no more reason for anxiety as to prices in the future, and dealers in this market who were nervous on account of the news printed concerning the result of the negotiations, have renewed confidence in the situation.

Recent Publications.

EVANS'S ESSAYS: PRACTICAL HINTS TO RETAIL JEWELERS: by CHARLES T. EVANS, 248 pages, octavo, bound in cloth. Published by Walter B. Frost & Co., Providence, R. I. Price, \$1.50.

THE aim of this work, which is written by a practical jeweler, is to assist members of the craft to conduct their business on a more profitable basis. As the title indicates, the book consists of a number of brief essays on topics of vital importance to the retail jeweler as a store-keeper.

In the opening chapter the author dwells upon the advantages and opportunities offered by the retail jewelry business, and lays down certain rules as requisites of success, besides giving admonitions for the avoidance of well-defined dangers. The book gives the jeweler useful information as to how the various departments connected with the retail jewelry business may be conducted, including the repairing department, engraving department, optical department, etc., etc.

A brief but exceptionally important chapter is devoted to a discussion of credit. The author emphasizes the readiness with which credit is extended to the retailer by the wholesaler, and shows how very necessary is caution in purchasing. The difference between wholesale and retail credit is also shown. It is to be regretted that the chapter on this topic was not further extended.

Not the least interesting chapter is one entitled "Starting a Store with Small Capital." It may be noted that THE CIRCULAR-WEEKLY, several years ago, conducted a prize competition for the best essay written along this line, and a prize was awarded to the author of this work.

Among other live topics discussed are: "The One Price System," "Disposing of Old Stock," "Cash Discounts" and "The Judicious Purchasing of Stock."

"ASK YOUR JOBBER"



PATENT PENDING

ONE OF THE NEW

UR

LOCKET RINGS

WHICH NOT ONLY HAS THE ADVANTAGE OF A PATENT SECRET JOINT, BUT HAS THE ADDITIONAL VALUE OF BEING WATER-TIGHT.

The Untermeyer-Robbins Co.

Seventy-One Nassau Street, New York

We have the most approved
Reducing Machines

Crees & Court
Die Sinters

21 Eddy St., Providence, R.I.

DIES

FOR

**JEWELRY
SILVERWARE**

Medals
Emblems
Brass Goods

Write us for a
Selection of
DESIGNS

CHARLES M. PRIOR, Designer

Designs for Gold and Silversmiths.

I have added Ornamental Engraving to my Etching Department.

'Phone 1639 Gramercy

24-26 East 21st St., NEW YORK

Pittsburg.

Thomas Currans has gone to Chicago on a business trip.

Charles S. Moore has gone out on the road for Sam F. Sipe.

George C. Pittfield, father-in-law of P. C. Gillespie, of Gillespie Bros., died last week.

L. J. Vilsack & Co. have moved into their new quarters at 539 Wood St., formerly occupied by Chas. O'Brien & Co.

The Pittsburg Jewelry Mfg. Co., formerly located at 502-504 Pittsburg Life building, has moved to new quarters in rooms 225-227 Bessemer building.

Sam F. Sipe and Mrs. Sipe spent last week in Kokomo, Ind., where Mr. Sipe went to attend a family reunion. It was a most enjoyable affair. He also visited Indianapolis.

The Weisser-Lowe Co. last week made a settlement with its creditors on a basis of 50 cents on the dollar, and has been conducting a clearance sale, which has been very successful.

S. Davis & Co. celebrated their 15th anniversary Monday. The firm was organized in 1893. Mr. Davis, who has been ill, is again at his place of business, giving it his entire attention.

Gillespie Bros. are carrying an advertisement in the Grand Opera House programme showing a picture of "The Dutch Wind Mill," a photograph of which appeared in THE CIRCULAR-WEEKLY several weeks ago.

J. Alexander Hardy, of the Hardy & Hayes Co., has written a letter to the City Hall Commission, recommending the Market House site as the proper place to erect the proposed \$1,000,000 city hall. Most of the downtown business men favor this site.

Among the jewelers from out of town who were in Pittsburg last week buying goods were the following: L. C. Grassel, Mahoningtown; P. J. Manson, Jeanette; A. Mertz, Sewickley; H. L. Sher, Vintondale; Henry Bloser, New Kensington; D. D. Cleeland, Butler; H. B. Potthof, Latrobe; Harry Furtwangler, Greensburg.

Mrs. A. Bennett, who was arrested at Sharon with her husband, charged with the robbery of Renzor's jewelry store last February, is alleged to have made a statement to the police in which she names Peter McCarty as having left part of the plunder in her house. Bennett was arraigned for a hearing Friday, and held in \$1,000 bail to answer the charge against him.

Charles McCarthy, who says he has no home, and Edward Doyle, who gave the Hotel Yoder as his residence, were arrested, last week, by Detectives Egan and Dalton on suspicion of being implicated in robbing the jewelry store of J. R. Reed & Co. in Market St., last week. Someone broke the south show window and made away with a tray of watches. Other arrests are expected.

The \$1,000 jewelry robbery at Claud Renzor's store at Sharon, Pa., according to information received in Pittsburg from that place, has been solved by the arrest of W. Roberts, South Sharon, at Coraopolis. The young man was taken in custody while endeavoring to dispose of a quantity of the stolen plunder. When Roberts was sweated by the police at Coraopolis he implicated

A Bennett, of South Sharon, Chief of Police Inskipt, of Coraopolis, went to Sharon and secured a search warrant, and, accompanied by Chief of Police Cunningham, searched Bennett's house. They are alleged to have found a suit case filled with jewelry, which was identified by Reznor. Both Bennett and his wife have since been placed in jail, and Roberts will be taken to Coraopolis for a hearing.

Considerable excitement was caused in the jewelry section of Pittsburg last week by the announcement that Charles M. Schwab, the steel magnate, had secured options on a large amount of the property bounded by Liberty Ave., 7th St., Penn Ave and 8th St. J. Alexander Hardy, of the Hardy & Hayes Co., is the owner of the Penn building, situated in Penn Ave., and the largest and best building in the block. There are a number of jewelers located in this building. Mr. Hardy admits that he was in New York last week, and that he had a talk with Mr. Schwab, but denies that Schwab has acquired any portion of the property owned by Mr. Hardy. The entire block is owned by nine different individuals, and is worth fully \$3,000,000. It is reported that Mr. Schwab is to erect a skyscraper on the property. S. Davis & Co., Graffner Bros., West, White & Christy, Iron City Jewelry Co., and a number of others are situated in this territory.

The Jewelers' Duckpin League last Thursday began the second half of the schedule. Roberts No. 1 team and Wattles No. 1 team had been tied, and came together to break a deadlock for first place. The Roberts team had no trouble taking three out of four games from Wattles, putting the Roberts team two games ahead in the standing of the clubs. The Vilsacks won three out of four from the Roberts No. 2 team. The Terheydens and the Reeds split even, each winning two games, Rhin of the Terheydens scoring his first century. Many women turned out to encourage the bowlers. The Roberts No. 1 team have won 17 and lost five games; Wattles No. 2 won 15, lost seven; Roberts No. 2 won 10, lost nine; Reed won and lost 11; Vilsack won seven, lost 11; Wattles No. 2 won eight, lost 12; Terheyden won seven, lost 15; Siedels lost three. It is proposed to enlarge the league for next season and have 12 clubs. The present season will come to a close in May, at which time the members of the league will give a banquet.

Brockton.

Herman L. Hewett, retailer, last week joined the ranks of the automobilists. S. D. Grossman, head of S. D. Grossman & Co., retail and jobbing jeweler, entertained over 100 friends the evening of April 2 at a housewarming. He has just erected a handsome dwelling, and dedicated it with a party to many Rebekahs, in which order his wife is prominent, and to their husbands. His guests presented him with a costly and beautiful china dinner set.

Burglars, on Sunday night of last week, entered the jewelry store of G. Rohrer, on Hecla St., Laur'um, Mich., and stole about \$200 worth of stock. The loot includes gold watches, opera glasses, necklaces, etc.

JARDINIERES

Frank M. Whiting & Co.

SILVERSMITHS
NO. ATTLEBORO, MASS.

320 Fifth Avenue, New York



Our extensive line of this entirely new and seasonable article is now being shown for the first time by our representatives.

The beauty and utility of these pieces should appeal to every Retail Jeweler as they are useful for table decorations with either potted plants or cut flowers.

Made in all sizes from two to six inches, and engraved to match our line of Plateaus in conjunction with which they make an especially complete gift.

Prices from \$3.00 to \$40.00 each.

Roger Williams Silver Co.,

PROVIDENCE, R. I.

Sterling Only.

RICH DESIGNS :: :: Photos. on Application.

Gems and Precious Stones

Cloth, Postpaid, \$1.00 Published by The Jewelers' Circular Publishing Co., 11 John Street, New York.

GORHAM SILVER

EASTER GIFTS AND EASTER WEDDINGS.

¶ The near approach of the Easter Festival must suggest to the alert minded Jeweler the necessity of providing for the special calls which will surely be made upon his stock of Gorham Silver.

¶ Year by year the Easter gift becomes increasingly popular as a token of friendly esteem and affection, while Easter weddings succeed the solemn Lenten season as day succeeds to night.

¶ For Wedding and for Easter gifts, therefore, fitting preparation has been made by the Gorham Company by the production of numberless appropriate articles ranging from the daintiest of trifles to the most elaborate of special pieces.

THE GORHAM COMPANY,



CHICAGO,
137 Wabash Ave.

Silversmiths and Goldsmiths

Fifth Avenue and 36th Street, New York.

BRANCHES:

NEW YORK,
23 Maiden Lane.

SAN FRANCISCO,
Temporary Office:
1103 Broadway, Oakland, Cal.



LONDON,
Ely Place.

WORKS: Providence and New York.

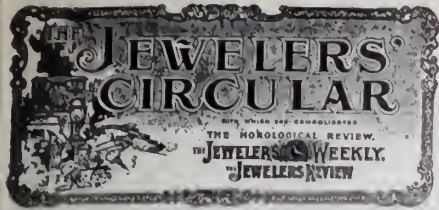

PUBLISHED EVERY WEDNESDAY BY
THE JEWELERS' CIRCULAR PUB'G CO.
 L. J. Mulford, Pres. & Treas. V. S. Mulford, V. P. & Sec.
 11 JOHN ST., COR BROADWAY, NEW YORK.
 TELEPHONE: CABLE ADDRESS:
 1148 CORTLANDT. JEWELAR, NEW YORK.

VOL. LVI. APRIL 8, 1908. No. 10

Subscription in United States and Mexico, \$2.00
 Dominion of Canada, 3.00
 Other Countries in Postal Union, 6.00
 Single Copies,10

Remit by check or money order. Remittances in money are at sender's risk.

Index to News and Special Articles.

	Page.
A Magnificent Christening Set. Illustrated on front cover; text on	35
Meerscham in New Mexico	35
Elsie Bee's Fashions	36
Interesting Statistics as to Gold and Silver Used in the Arts	37
Reigning Paris Fashions	39
Exports of Jewelry, etc., From New York	39
The News From England	41
Importations at the Port of New York	43
Death of Harry A. Scofield	43
The Career of the Late Eli Hertzberg	43
Trustee Appointed for the Business of T. Sorensen	43
Death of Charles E. Bliss	45
D. A. White Co. Makes an Assignment	45
Death of Uriah C. Smith	45
Members of the Jewelers' 24-Karat Club Hold Enjoyable Beefsteak Dinner and Meeting	47
Career of the Late N. A. Capron	47
National Monthly Import and Export Statistics	47
Fifth Annual Dinner of the Jewelers' Bowling League	49
Involuntary Bankruptcy Against F. G. Happel & Co., Chicago	51
Maurice Dreshfield Examined in Bankruptcy Proceedings as to Diamonds He Obtained From R. A. Breidenbach	51
Death of Louis H. Davis	51
Temporary Receiver Appointed for the Business of Parker, Kolb & Co.	52
Fire in Omaha, Nebr., Does Considerable Damage to Jewelry Stock	52
Association Notes	53
Bids Received and Contracts Awarded by Government	53
Gold Bars Withdrawn and Exchanged	53
New Enterprises	54
Jewelry, Clocks, Plated Ware, etc., Shipped to Alaska, Porto Rico, Hawaii and the Philippines	55
Letters and Cables Received at Antwerp as to Diamond Market	55
Recent Publications	55
Silver Bars	59
Patent Department	79-81
Registration of Trade-Marks and Trade Names in Peru	81
The Terminal Curves of the Balance Spring and the Adjustment of Watches	83-85
Results of the Competitive Trials of the Chronometers at the Astronomical Observatory of Neuchatel	87
An Automaton Clock Made by a Pennsylvania Watchmaker	87
A Clever Window Attraction	87
The Best Arrangement of the Storeroom in Order to Get the Maximum Amount of Daylight	96
A Representative Retail Jewelry Store of Houston, Tex.	97
A \$75,000 Display of Precious Stones	97
Workshop Notes and Queries	99
Hard Genuine Babbitt	99
The Sphymometer	99
Old Denby Salt-Glazed Stoneware	101
An Interesting Lecture on Enamels	101
The Status of Foreign Corporations Doing Business in Illinois	103

THE importations of precious stones and pearls in the Port of New York during the month of March, while a little more than 10 per cent. of the amount imported in the corresponding month of last year, showed a distinct increase over the amount imported during February; in fact, the value of the cut precious stones and pearls which in February aggregated but \$24,583 increased last month to \$298,879, and the uncut stones jumped in amount from \$24,588, in February, to \$90,634.77 in March. The total for last month amounted to \$389,514.67, while the same importations a year ago amounted to \$3,296,281.

Publicity Gives Protection Against Criminals.

WE again wish to urge subscribers of THE CIRCULAR-WEEKLY to read this journal carefully each week in regard to the news about the operations of thieves and swindlers, and also to co-operate with us in protecting the trade by giving us information of every attempt at theft or swindling that is made in their vicinity, even though they may not have been the victim or the party on whom the thieves have tried to work their tricks. Hardly a week passes that this journal does not receive words of commendation from its subscribers who have carefully read the accounts published in our columns from time to time and thereby have been saved from loss. In the last week two Texas firms have written us, thanking us for publishing the account of the man and woman attempting to swindle jewelers of Iowa and Nebraska by offering spurious jewelry for more than it was worth, saying that the details published about the methods of this pair had saved them from loss, as these people appear to be working Texas at the present time and must have gone south instead of continuing their operations in the middle west.

On the other hand, despite the fact that we have published the account of the operations of a short-change swindler, telling of the way he succeeded in getting jewelry in Cincinnati, Pittsburg, Brooklyn, etc., we continue to receive accounts, from time to time, of his operation in other cities. In almost every instance he has been successful in obtaining jewelry to a large amount, often up in the thousands of dollars, for which he gives the jeweler simply a number of one-dollar bills. His method in almost every instance has been the same, paying for his purchase in a few large bills and a number of one-dollar bills, handing his victim the money, but always one dollar short of the amount required. When the jeweler counts the bills he sees the error and calls attention to the shortage. The swindler then takes the money, counts it himself, agrees with the jeweler and gives him one dollar additional; but in handing back the money he slips out the large bills (in some cases they are bills of \$500 denomination) from the bottom and simply gives the jeweler the roll of single dollar notes. It should be mentioned, however, that many of the man's victims have not been readers of THE CIRCULAR-WEEKLY, though one of them was, as were also two others with whom the swindler came near being successful.

In view of the fact that this swindler has

The fellow who tries to attract business without advertising, is like the fellow who throws his sweetheart a silent kiss in the dark. He knows what he is doing, but nobody else does.

—W. J. BRYAN, On Advertising.

not yet been captured, we again warn the trade to be on the lookout for him, and should they hear of his operating in their vicinity to immediately let us know. At the same time all jewelers should be careful to see to it themselves and instruct their employes to be very cautious in dealing with customers who pay for valuable gems with a few large and many small bills, especially when the man gives in payment a sum less than the amount called for. In such cases there is always danger in allowing the property to go out of one's possession until the money given therefor has been recounted and found to be correct.

Newspapers Find It Hard to Explain.

WORD was received from Amsterdam last week to the effect that the Diamond Workers' Union by an overwhelming majority of 5,001 to 390 had decided to completely cease work during the month of April. It is said that this will affect nearly 10,000 men in the diamond polishing and cutting trades. According to the dispatches, when the work is resumed the union intends to demand higher wages for its members.

It is unfortunate for those newspapers of the country that have been misinterpreting the news about the diamond market recently that there was absolutely nothing in the dispatch in question that they could turn or twist into meaning that there was a chance for diamonds to be lower in price. In fact, some of them even had to admit in their comments on the news that it meant that cut diamonds would be less plentiful and that the increase in the cost of cutting might mean an increase in price.

With the official announcement sent out by the De Beers and Premier companies, and also by the Syndicate that there would be no change in prices of diamonds, and with the cutters stopping work and demanding an increase in wages, those newspapers that have been trying to make their readers believe that diamonds would soon be "on the bargain counter" are in a somewhat uncomfortable position. Explanations are truly in order, but we doubt very much if they will be forthcoming.

Market Price for Silver Bars.

The following are the quotations of silver bars in London and New York, as reported by Zimmermann & Forshay:

	London.	New York.
	.999 Basis.	
March 31	25 9-16d.	.57½%
April 1	25 1-2d.	.57¼
" 2	25 1-2d.	.57¼
" 3	25 7-16d.	.57½
" 4	25 7-16d.	.57½
" 6	25 7-16d.	.57½

A Profitable Investment for You

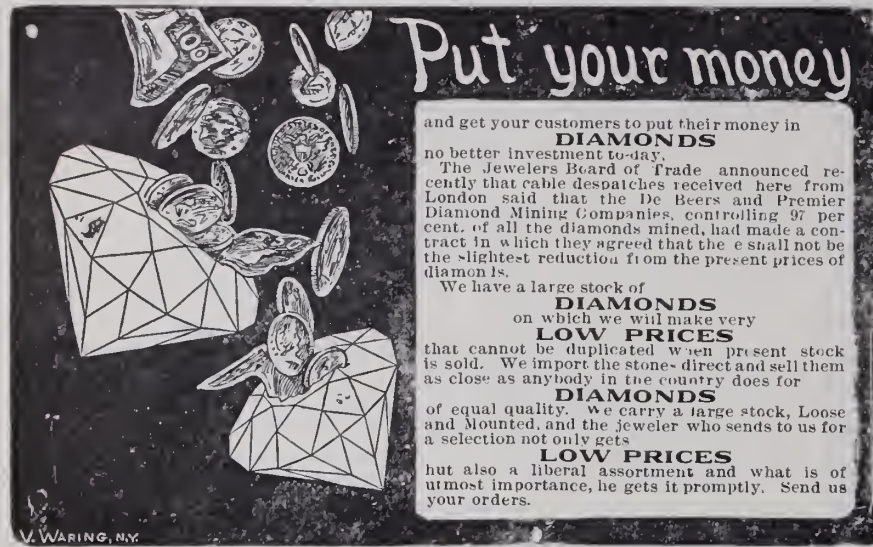

Put your money

and get your customers to put their money in **DIAMONDS** no better investment to-day.

The Jewelers Board of Trade announced recently that cable despatches received here from London said that the De Beers and Premier Diamond Mining Companies, controlling 97 per cent. of all the diamonds mined, had made a contract in which they agreed that there shall not be the slightest reduction from the present prices of diamonds.

We have a large stock of **DIAMONDS** on which we will make very **LOW PRICES** that cannot be duplicated when present stock is sold. We import the stone direct and sell them as close as anybody in the country does for **DIAMONDS** of equal quality. We carry a large stock, Loose and Mounted, and the jeweler who sends to us for a selection not only gets **LOW PRICES** but also a liberal assortment and what is of utmost importance, he gets it promptly. Send us your orders.

V. WARING, N.Y.

CROSS & BEGUELIN

Importers and Cutters of Diamonds and Precious Stones

43 Rue de Meslay, PARIS

Telephone,
480 John

31 Maiden Lane, NEW YORK



Trade-Mark

OUR guiding principle has always been to incorporate as much artistic skill and good material in the construction of our jewelry as possible. This is contrary to the skimming, economic operations so extensively practiced in the manufacture of inexpensive gold jewelry. In observing this standard we naturally sacrifice the petty profits resulting from the less exacting methods of others; nevertheless our jewelry is consistently low priced and of a quality away beyond the ordinary.

Ask to see it and look for our trade-mark—the imprint of originality and all that's good.

85 Sprague Street
PROVIDENCE, R.I.

H. A. KIRBY

9-11-13 Maiden Lane
NEW YORK CITY

Lancaster, Pa.

TRADE CONDITIONS.

A majority of the local jewelers report a better tone to business, and all say the indications point to early improvement in trade, due to heavy buying of the new tobacco from the farmers. April 1, the annual "Settlement Day" for Lancaster County, brought the jewelers considerable business.

W. T. Gardner has taken a position as jeweler with W. W. Appel.

Charles Jussek, late with W. W. Appel, has opened a jewelry store at 137 E. King St.

John L. Carr, Lancaster, has entered the technical school as a student in watchmaking.

John B. Roth, Jr., manufacturing jeweler, has just finished for Worth's Business College, Lancaster, a set of five class pins.

Marcus Edelstein has erected in front of his store on N. Queen St. an attractive electric sign in the form of a huge watch.

Percy P. Beckman, a St. Louis jeweler, spent several days last week with Lancaster friends, stopping over on his way for a week's visit to New York.

Robert S. Gitt, Harrisburg; Thomas Powers, Wilmington, Del., and Jacob Noble, Washington D. C., were among the few jewelers who visited Lancaster last week.

Alderman Stauffer last Friday committed John Davis and Elmer Lewis to await investigation as suspicious characters. A lot of jewelry, supposed to have been stolen, was found in their possession.

The traveling salesmen of the Non-Retailing Co. have left to cover their respective territories—E. R. Kant to New York and Ohio; F. A. Wheeler to western Pennsylvania, and C. E. Foose for the south.

G. William Reisner has just finished a handsome solid gold Past Exalted Ruler's jewel, set with diamonds, for the Hagerstown, Md., Lodge of Elks, and a solid gold Past Worthy Ruler's jewel for Independence Lodge, Fraternal Mystic Circle, of Philadelphia.

T. Wilson Dubbs, N. Queen St., has offered a handsome gold watch, 17 jeweled, Hamilton movement, to the player of the Lancaster Tri-State League baseball team making the first home run on the home grounds this season. He made a similar offer last season.

Wendell D. Swartz, Lehighton, Pa., late a student of watchmaking at the local technical school, has bought out the jewelry store of Frank H. Barndt, at Birdsboro, Pa., and will open it for business in a few days. Mr. Barndt retires after being in business 30 years at Birdsboro and Lehighton.

A fire occurred April 3 in an alley immediately in the rear of the establishment of the H. S. Meiskey Co., in which a lot of gasoline figured. The fire was in the neighborhood of G. William Reisner's factory also. The flames were extinguished before serious damage was done, and without harm to the jewelry store.

W. F. Crane, Conroe, Tex., is reported to have sustained a loss of \$1,000 during a fire at that place, March 22.

Charles Hanson, formerly in business at Mason City, Ia., is now traveling representative for a wholesale jewelry house in Chicago.

New York Notes.

J. W. B. Junsch, watch and clock maker, has removed from Brooklyn to 6 John St., Manhattan.

Bernard Italie, of the Koshland & Italie Co., Philadelphia, Pa., was in town Friday of last week.

George W. Korper, 2 Maiden Lane, is receiving the congratulations of friends on the arrival of a son.

Fred Barry, formerly with J. A. & S. W. Granbery, Newark, N. J., has taken a position with Louis Stern & Co.

The New York office of Kautzmann & Co., formerly Kautzmann & Sussfeld, will be moved, May 1, from 13 Maiden Lane to 170 Broadway.

Judge Holt has confirmed the composition in bankruptcy at 50 cents on the dollar offered by Louis Witsenhausen, 49 Maiden Lane, and accepted by creditors.

Philipp J. Breivogel, watchmaker, will remove on May 1 from 1 Maiden Lane to the Sheldon building, 68 Nassau St., where he will occupy room 11 on the 11th floor.

Frederick W. Rauch, dealer and broker in diamonds, pearls and precious stones, formerly with Kleinschmidt, Howland & Co., has opened an office at 9 Maiden Lane.

A letter sent out by the Jewelers Board of Trade announces a membership in the Board of 559. Over \$221,000 was collected for the members of the Board during the year without expense to them.

G. Cheever Hudson, of G. C. Hudson & Co., North Attleboro, and Alpin Christolm, of the Bugbee & Niles Co., also of North Attleboro, sailed, April 1, on the *Mauretania* for London and Paris, to be gone five or six weeks.

The examination of David Kessler, 226 Henry St., against whom a petition in bankruptcy was filed some time ago, which was set down for last Thursday before Referee Miller, 2 Rector St., was adjourned until Friday, April 10, at 11 A. M., at the same place.

The Manhattan Bead Co. has been incorporated under the laws of the State of New York to manufacture beads, necklaces and novelties, with a capital of \$10,000. The incorporators are Jacob Wolf, Arnold Minnerberg and Sieg. Rosenberg, all of New York.

There is on exhibition in the Fifth Ave. salesrooms of Tiffany & Co. a massive piece of jade weighing 1,239 pounds, which was brought from West Island, New Zealand. A card states that orders will be taken by Tiffany & Co. for articles to be cut from the rock.

Alfred Schickerling, of the Elk Jewelry Mfg. Co., 51 Maiden Lane, returned from Europe recently. He brought with him a new idea in loving cups. The cup is to be made so that two people may drink from it at the same time. The idea has been patented by Mr. Schickerling.

Members of the trade have been commenting favorably in the past week on the Imperial Westminster electric cathedral chimes, which were sold to "Ye Old Dutch Tavern," 23 John St., recently, by the W. Green Electric Co. The bells toll out the chimes with great clearness.

Henry Fera, of Fera & Kadison, 65 Nassau St., accompanied by his wife, sailed,

Tuesday of last week, on the *Hamburg* for Europe. They will be absent about two months, part of which time will be spent in Italy. This trip marks the 100th voyage of Mr. Fera across the Atlantic.

The auction sale of unclaimed goods at the seizure rooms of the Appraisers' Stores, 641 Washington St., commenced yesterday, and will continue until all the goods are sold. Included in the articles offered are three nickel watches and chains, 12 empty jewel boxes, rings, watch chains, scarf pins, etc.

The L. Witsenhausen Co. has been incorporated under the laws of New York State with a capital of \$20,000. The directors are Louis Witsenhausen, Edward Maroney and Maurice Ballin. John Drake claims that the use of his name in the list of incorporators of this company was unauthorized.

There has been on exhibition in the windows of the Julius King Optical Co., 10 Maiden Lane, during the past week a model of the battleship *Kearsarge*, which has attracted much attention from passers-by. The model is carefully worked out and the detail is very accurate. The model was built by J. H. Graef.

Relatives of the late Wilbur Irving Follett, president of the Follett Time Recording Co., are making efforts to recover a gold trophy cup which disappeared from the offices of the company, Ninth Ave. and 11th St., when that building was burned March 17. The late Mr. Follett won the cup in a tournament at the Merdew Brook Golf Club several years ago, and was saving it to present to his eldest son.

Another attempt was made early last Wednesday morning to rob the store conducted by Mrs. Agnes Hawkins, 727 Eighth Ave. Three young men were sleeping in the store and were aroused by the smashing of one of the windows. They dressed quickly and started to investigate the matter. They were met by a policeman who had in custody a negro, who had been detected in an attempt to rob the store. The negro gave the name of James Moore. He was held for examination.

Representative merchants and property holders in Fifth Ave. met at the Holland House last week and organized the Fifth Ave. Association for the purpose of working together in an effort to improve and beautify that avenue. The association starts out with a membership of about 100 firms, and it is expected that this membership will be greatly increased. The constitutions and by-laws were adopted and an executive committee elected, among the members of which are J. S. Holbrook, of the Gorham Co.

Alfred J. Minner, 281 Jackson Ave., Long Island City, was aroused about 1.30 A. M. last Thursday by Patrolman Morgan, of the Hunters Point Precinct, with the startling information that the front door of his store had been found wide open. The jeweler lost no time in reaching his place of business. An examination showed that nothing was missing and that no one had been in the store. Mr. Minner thinks he forgot to lock the front door on closing his place of business, but it is not known who opened the door.

The Spring exhibit of the National Arts

Club was opened Thursday night at 119 E. 19th St. The exhibit includes handicraft and architecture, as well as painting and sculpture. Included in the exhibit is pottery from the Volkmar kilns, while Mrs. Clara L. Poillon shows vases and bowls mounted on wicker stands in a very clever and practical way. Miss Marie Zimmermann has a case full of jewelry designed and executed by her; Mrs. Leonard shows painted porcelains, and Miss Lora Thompson has an exhibit of jewelry, lamp shades, leather and other objects of the applied arts.

A case of interest to the jewelry trade came up before Appraiser Sharretts Friday morning in regard to the duty on hat pins set with imitation precious stones. These articles were assessed at 60 per cent. as manufactured articles of glass, cut. The importers claim that the duty should be 15 per cent. under Par. 112, which provides for manufactures of paste. The contention rests on the question as to whether the articles in question can be classed as cut glass or simply as imitation or paste. The case has been brought up by several concerns. An adjournment of two weeks has been taken.

George Hauff, or George Hoffman, was arrested, March 31, on the charge of trying to steal a gold watch and chain from the Reed & Barton Co., 320 Fifth Ave. Hauff went to the Fifth Ave. store of the concern and selected a gold watch priced at \$77 and a chain valued at \$29.75, which he ordered sent to his address at 236 Court St., Brooklyn. Charles A. McIntyre, a trusted employe of the firm, was sent to the Brooklyn address with the articles, with orders to collect the money. Hauff, he says, asked to see the watch and chain, and then motioned him to a chair, telling him to write out the receipt and the money would be paid. As soon as Mr. McIntyre's back was turned, he says, Hauff grabbed up the watch and chain and ran out of the door, slamming it shut behind him. When McIntyre succeeded in reaching the street the man had disappeared. He at once called up the New York office, reported the matter at the Butler St. police station, and two detectives were assigned to the case. The officers later found Hauff, and also found 10 pawn tickets on his person, among them one for the watch and chain. The articles had brought \$30. The prisoner was held by Magistrate Tighe in default of bail for examination.

A recent decision by the Board of United States General Appraisers holds that beads of real jade, strung on silk threads, finished with tassels of red silk threads and ornamented with silver wire, sold and worn as necklaces in the condition in which they are imported, are properly dutiable as jewelry, and as such must stand a duty at the rate of 60 per cent. ad valorem. The question came before the Customs authorities in the form of a protest by Sun Wing Wo & Co., Los Angeles, Cal., who objected to the high assessment made by the authorities and contended that the beads of jade should be admitted as strung temporarily for convenience in handling or transporting, and under this contention dutiable at 10 per cent. Appraiser Sharretts says that inasmuch as the beads are worn on the person

1851

The Jeweler's Bank for half a century
in the same location.

1908

THE CHATHAM NATIONAL BANK

Broadway and John Street, New York

ACCOUNTS INVITED

GEORGE M. HARD, President WILLIAM H. STRAWN, Cashier HENRY L. CADMUS, Assistant Cashier

Title Guarantee and Trust Company

176 Broadway (between John St. & Maiden Lane)
NEW YORK

Capital and Surplus, \$12,000,000 :: The Depositor's best guarantee is a large capital and surplus, together with conservative management

TRUSTEES

John Jacob Astor, 23 West 26th St., New York
Frank Bailey, Vice-President
E. T. Bedford, President Corn Products Refining Co.
Charles S. Brown, of Douglas Robinson, Charles S. Brown & Co.
Julien T. Davies, of Davies, Stone & Auerbach
William M. Ingraham, Attorney-at-Law, 44 Court St., Brooklyn
Augustus D. Juilliard, of A. D. Juilliard & Co.
Martin Joost, Vice-President Bond & Mortgage Guarantee Co.
Clarence H. Kelsey, President
John S. Kennedy, Retired, 31 Nassau St., New York
Woodbury Langdon, of Joy, Langdon & Co.
James D. Lynch, Retired, 129 East 21st St., New York
Ranald H. Macdonald, of R. H. Macdonald & Co., Real Estate
James H. Manning, President National Savings Bank, Albany
Edgar L. Marston, of Blair & Co.

Wm. J. Matheson, of W. J. Matheson & Co., 182 Front St.
Charles Matlack, 70 State St., Boston
William H. Nichols, Chairman of Board, General Chemical Co.
William A. Nash, President Corn Exchange Bank
Robert Olyphant, of Ward & Olyphant
Charles A. Peabody, President Mutual Life Insurance Co.
William H. Porter, President Chemical National Bank
Frederick Potter, 71 Broadway, New York
Charles Richardson, 1307 Spruce St., Philadelphia
Henry Roth, 1562 Myrtle Ave., Brooklyn
Jacob H. Schiff, of Kuhn, Loeb & Co.
James Speyer, of Speyer & Co.
Sanford H. Steele, of Steele, Otis & Hall, Attorneys
Ellis D. Williams, 560 Drexel Bldg., Philadelphia
Louis Windmuller, of Louis Windmuller & Roelker

BRANCH BANKING OFFICES: 196 Montague St. and 175 Remsen St., Brooklyn; 350 Fulton St., Jamaica; 67 Jackson Ave., Long Island City

The Market and Fulton National Bank of New York

ORGANIZED 1852

81-83 FULTON STREET

Capital, \$1,000,000

Surplus, \$1,500,000

PROGRESSIVE—CONSERVATIVE—SUCCESSFUL

ALEXANDER GILBERT, President
R. A. PARKER, . . . Vice-President
T. J. STEVENS, Cashier
JOHN H. CARR, . . . Asst. Cashier

Invites the Accounts of Jewelers
Will extend every facility that good banking will justify
SAFE DEPOSIT VAULTS

THE STATE BANK

376-378 GRAND STREET, NEW YORK

Capital and Earned Surplus, over \$1,500,000. Deposits over Fifteen Millions.

Offers a favorable market for short and long time jewelry and diamond paper.

The Mercantile National Bank

OF NEW YORK

WILLIS G. NASH, President

MILES M. O'BRIEN, Vice-President

WM. SKINNER, Vice-President

WILLIAM H. TAYLOR, Vice-President

EMIL KLEIN, Cashier

DIRECTORS

WILLIAM F. CARLTON,
ROBERT C. CLOWRY,
WILLIAM NELSON CROMWELL,
L. H. CUTTER,
EDWIN GOULD,
HAROLD A. HATCH,

EDWARD T. JEFFERY,
WILLIAM H. LAWS,
WILLIS G. NASH.
BENJAMIN NICOLL,
MILES M. O'BRIEN,
CHARLES E. PERKINS,

DICK S. RAMSAY,
WILLIAM SKINNER,
E. D. STREET,
WILLIAM H. TAYLOR,
E. J. TRUSSELL,
WARNER VAN NORDEN,

Strictly a Commercial Bank
Accounts Solicited

The Silversmiths' Building

15-17-19 MAIDEN LANE

EDWARD HOLBROOK, President

☞ Location unsurpassed. ☞ In the center of the jewelry and silverware trade, not only in this city but this continent. ☞ Magnificent views from the upper stories of the North and East Rivers, new bridges and general view of the Island of Manhattan. ☞ Occupied exclusively by the jewelry, silverware and kindred trades. ☞ This building has been largely advertised by the owners and that in turn is now being taken up by the tenants not only in this country but in Europe.

Tenants Now Moving In

AMONG WHOM ARE THE FOLLOWING :

Adams, Thomas W., & Co.
Aikin-Lambert Company
Barrett, Nephews & Co.
Barrows, H. F., Company
Blackinton, R., & Co.
Bliss Brothers Company
Block Bros.
Bowden, J. B., & Co.
Brokaw, D. D.
Bruhl Bros. & Henius
Draper, Estate of O. M.
Durgin, Wm. B., & Co.
Elgin National Watch Company
Ford & Carpenter
Goddard, Ira
Gorham Company, The
Heacock, H. E.
Hicks', W. S., Sons
Himalaya Mining Company
International Silver Company
Jewelers' Association & Board of Trade



Jewelers' Protective Union
Jewelers' Safety Fund Society
Kerr, Wm. B., Company
Mabie, Todd & Co.
Maebert & Reiss
Marden & Kettlety Company
Marx, Charles
Mead, M. A., & Co.
Queen City Silver Company
Robbins, The Chas. M., Company
Silversmiths' Company, The
Spencer, E. L., Company
Standard Button Company
Tannenbaum, L., & Co.
Towle Manufacturing Company
Union News Company
Watson, Newell & Co.
Weinberg, Isaac H.
Weiner, Garson & Naigles
Whiting Manufacturing Co.
Williams Bros. Mfg. Company
Wood, Charles F., & Co.

☞ Handsomely ornamented booths in the Arcade will be occupied for the sale of Periodicals, Confectionery, Cigars. Also Bootblack and Barber Shop Establishments.

RENTALS ARE NOW BEING MADE. FOR PLANS AND PARTICULARS APPLY TO

GROSS & GROSS COMPANY, Managers

COURTLAND E. HASTINGS, Agent

171 BROADWAY, ROOM 5

New York Notes.

(Continued from page 61.)

for ornamentation the Collector's action in returning the articles under the jewelry clause is correct.

James A. Pitts, Montreal, has just returned from a trip to Europe. He was in his city Monday.

R. Dreyfus, of the Dreyfus Mfg. Co., sails to-morrow on the *Amerika* for his annual European purchasing trip.

Benjamin F. Rees, of Zimmern, Rees & Co., returned recently from a European trip on the *Kaiser Wilhelm der Grosse*.

George Schaefer, formerly with Regnell, Bigney & Co. 15 years, is now with C. O. Sweet & Son Co., traveling for them in the middle west.

Lewy & Cohn, 530 Broadway, have just received at their offices three French art studies by famous artists. Two of the pictures are painted on kid and one is on silk.

Wm. H. Cotton received a letter last Friday sent by 60 employes of Tiffany & Co., as a reminder of the 90th anniversary of his birthday. He was in the employ of Tiffany & Co. over 43 years.

In speaking about a parcel of Brazilian rough diamonds a note in last week's issue mentioned the weight of each stone, one-half carat. The weight should have been stated as one and one-half carats.

S. Marchand, of Marchand Freres, arrived from Paris on *La Provence* Saturday. A. Marx, who was many years with Marchand Freres as bookkeeper, retired recently with the sincere regrets of his employers.

An exceptionally interesting exhibition of jewelry and Egyptian stones, beads, metal and leather work was held Monday and Tuesday afternoon and evening at the studio of Miss Harriet Keith Fobes, Tammany Hall.

Included in the list of the Grand Jurors of New York County sworn in Monday are Benjamin F. Rees, of Zimmern, Rees & Co., 14 Maiden Lane. The second Grand Jury contains the name of David Belais, of H. & E. O. Bela's & Co., 102 Fulton St.

A report is current in the Lane to the effect that Reisenweber's restaurant man is about to take over the restaurant conducted by Mr. Gibson at 57 Maiden Lane, and that he will conduct a restaurant there. It is expected that he will cater especially to the jewelry trade.

The examination of the matter of Kleinschmidt, Howland & Co., 170 Broadway, New York, against whom a petition in bankruptcy was filed in New York some time ago, was continued Monday afternoon before United States Commissioner Alexander. The examination of David Townsend was taken up and he was questioned relative to a \$71,000 transaction which took place between himself and Kleinschmidt, Howland & Co.

After a chase of four months William F. Mannix, 33 years old, of Malone, N. Y., was brought back to this city last week and locked up at police headquarters on the charge of grand larceny. Mannix was arrested in Montreal. According to the police Mannix last December went to Tiffany &

Co. and presented letters purporting to be from W. A. Tidd, of the Lewis House, Carthage, N. Y., and J. A. Van Vechten, of Chautauqua, N. Y. On these letters Mannix is said to have received \$506 worth of jewelry. Later, the police say, the letters were found to be forgeries.

At a meeting of creditors of J. B. Bennett & Co., Norfolk, Va., held Monday afternoon at the Jewelers Board of Trade rooms, the creditors agreed to accept an offer of 50 cents on the dollar in settlement of their claims; this is to be payable in notes for six, nine, 12, 15 and 18 months and indorsed by Sarah A. Bennett, wife of the debtor, to be secured by a mortgage on her realty. This proposition met with the approval of the creditors providing the equity proves to be all right, the equity to be not less than \$15,000 to be acceptable to the creditors.

Jacob Schlesinger, a peddler of cheap jewelry, who says that he lives at 943 Longwood Ave., Bronx, was the complainant against Officer Cornelius Brassil, of the Butler St. station, in the Butler St. court, Brooklyn, last week. He claimed that Brassil had assaulted him by striking him in the face with his open palm, and hitting him on the wrist with a chain, on March 25, at the corner of Smith St. and Fourth Pl. Schlesinger was in court the day after the alleged assault, having been arrested by the officer for obstructing the sidewalk. He pleaded guilty to the charge which Brassil made against him to Magistrate Tighe. Magistrate Tighe suspended sentence and let him go.

Mrs. Ira Barrows, wife of Ira Barrows, of the H. F. Barrows Co., 37 Maiden Lane, has just recovered a neck ribbon of black silk studded with jewels and valued at \$1,250. Mrs. Barrows missed the collar a short time ago and thought she lost it while driving in an automobile. The ribbon and diamonds were found by central office detectives, and on information given by the pawnbroker three men were held for the alleged theft. The pawnbroker's ledger showed that "John Pitts," of 318 W. 52d St., "put up" the ribbon and gems. At that address the detectives found Edward Felts, a skating instructor, who, they said, admitted that he took the jewel studded ribbon from the room of Gustave Ramusen, a chauffeur living in the same house. The chauffeur, according to the detectives, said that the collar was given to him by John Connors, who is a footman employed by Mrs. Barrows.

The store of Dikran Kahn Kilokian, 275 Fifth Ave., was robbed Sunday night of last week of jewels valued at \$1,425. When the news of the robbery was reported to police headquarters a list of the stolen jewels was sent to all pawnbrokers, and detectives from the Central Office were assigned to the case. Antique jewelry, curios, rugs, etc., are sold at the store, and it was thought that the place was well protected with burglar alarms. The list of jewels taken include a large brooch of antique design made in the shape of a five-pointed star. In the center is a large, flawless ruby surrounded by diamonds, sapphires and emeralds. Among the other jewels were a pair of diamond and emerald earrings with long drop attachment, a long pearl

chain, a long chain set with emeralds, a pair of pearl earrings, an emerald brooch, a Turkish brooch formed of inscription with seven diamonds, one turquoise bracelet, small pearl pendant and a pair of yellow topaz and diamond earrings.

Newark.

Wm. I. Allsopp has succeeded to the business of Allsopp & Long.

B. M. Shanley, Jr., is now erecting for his own use a building at 1113 Governor St., where he will manufacture a line of fine gold jewelry. The building is to be equipped with all modern improvements.

A burglar recently forced open a front window in the home of P. L. Munford, a jeweler of East Orange, while the members of the family were away, and secured two brooches—one containing 30 pearls—together with a gold bracelet, a lady's gold watch, a plain unset gold brooch and two gold pins.

Kautzmann & Co. have taken over the assets and assumed all the obligations of the old firm of Kantzmann & Sussfeld, which firm has been dissolved by the withdrawal of A. Sussfeld. The business will be carried on at the same location as heretofore, with the exception that the New York office will be moved on May 1 to 170 Broadway.

A temporary jewelry store at the corner of Market and Plane Sts., conducted by Herman Streiff, was entered early last week and robbed of part of the stock. It was thought that about \$1,500 worth of valuables were taken. Mr. Streiff was robbed once before, it is said, in another town, on which occasion he is alleged to have been chloroformed and relieved of \$5,400 in money.

Chas. M. Sanford, a jewelry salesman, disappeared from his home, 784 S. Orange Ave., Friday morning last, and a search is being made for him. Mr. Sanford had intended to open a jewelry store at Broad and Cedar Sts., and had received part of his stock. He was awaiting other orders when he learned that New York dealers intended to withdraw their credit. Before his disappearance he bade his wife good-by as usual, but made no mention of going away. For the past four years Mr. Sanford has been in the employ of a Broad St. firm and resigned his position to go into business for himself.

Louis Kamm, last Wednesday, recovered jewelry and precious stones, taken from his factory at 160 Ferry St., two months ago by his partner, Carton Berntheizel, it is alleged, and placed in the hands of the New York creditors of the firm of Kamm & Berntheizel. To get back the goods and re-establish his credit, Kamm first had bankruptcy proceedings instituted and paid all debts of the concern. By order of Judge Cross, in the United States District Court, he was released from bankruptcy, and the receiver for the firm, Albert Haeffeld, ordered to turn over the jewels and stones, together with the keys of the factory, to Kamm, who had purchased the interest of his partner. Kamm reopened the place of business in Ferry St., Wednesday, under the name of Kamm & Co.

North Attleboro.

The B. S. Freeman Co. is taking account of stock.

Louis A. Blackinton is at the factory for a few days.

R. Blackinton & Co. are closed for 10 days for its annual stock taking.

Frank M. Whiting & Co. is closed for the week to take account of stock.

Riley & French are installing a large new boiler at their Broad St. factory.

J. F. Sturdy's Sons are installing a new boiler in their Robinsonville factory.

Mr. and Mrs. Herbert French have returned from an extended stay in Florida.

Henry Sonderregger, an employe of the T. I. Smith Co. for over 25 years, died Wednesday.

Louis D. Barrows has returned from the hospital, where he underwent an operation which proved very successful.

A telegram was received Thursday announcing the death of Harry A. Seofield, of the firm of Seofield, Melcher & Seofield, at his home in Brooklyn. The news was received with keen regret by the many friends of Mr. Seofield, who because of his genial ways was a great favorite here.

Mandalien & Hawkins have decided to move into the Manufacturers' building during April, and expect to be located by May 1. The new quarters will allow over 2,000 feet additional floor space, and will enable the concern to adequately care for the increased business that has come in the past few years.

The Manufacturers' National Bank opened on Thursday to depositors. Jewelers have been greatly handicapped the past few months because there was no local National bank, and the opening was therefore welcomed. The new bank has purchased the building and land of the defunct Jewelers' National Bank.

Many jewelry factories were closed Thursday afternoon out of respect for Attorney William H. Pond, whose funeral took place on that day. The bearers were John E. Tweedy, of Cheever, Tweedy & Co.; Fred A. Howard, of F. M. Whiting & Co.; C. Ray Randall and L. E. Morse, of the H. D. Merritt Co. Services were at the Grace Episcopal Church and burial at Foxboro.

Edwin Richards, one of the earlier jewelers, died Friday in his 86th year. Mr. Richards was interested with his brothers, Egbert and James, in the jewelry business when it was in its infancy. In 1849 Mr. Richards went westward during the California gold craze, and spent five years mining and hunting. He was known as the best fox hunter in New England. The funeral was held on Sunday.

The new bill relative to the promotion of industrial education in the high school introduced into the Legislature provides that the State shall reimburse to the extent of one-half all towns expending more than \$5 for every \$1,000 valuation, for support of schools; to towns spending more than \$4 and less than \$5 the reimbursement shall be one-third; for towns paying less than \$4 per \$1,000 valuation the reimbursement shall be one-fifth of the amount needed. In no instance shall any school receive more than \$2,000. No money will be given toward a

building or for ground or building rent. The money may be utilized for purchase of new equipment.

Attleboro.

George Schaefer will cover New York and the middle States for the C. O. Sweet & Son Co.

Louis B. Jones, salesman for C. A. Marsh & Co., has been enjoying rest and recreation at Sandwich the last few days.

Spring stock-taking is in progress with many of the concerns, and is causing the lay-off of many hands for a few days each.

W. Henry Blake, partner and traveling salesman for the James E. Blake Co., has purchased the old Charles Sturdy home-stand on S. Main St.

The majority of the traveling salesmen are getting ready to go out on trips on or about April 15. A few have made short trips in the east as feelers, and some started for long circuits and decided to wait till now. The real campaign for Fall trade will start in about a week to 10 days.

The D. E. Makepeace Co. has gone on five days a week after a short run on three days, the addition of 60 per cent. more time being due to a noticeable improvement in business generally. This concern makes an excellent barometer, as it furnished the manufacturing jewelers with a large quantity of their metal and other stock, and its prosperity means that others have orders to fill. Slightly longer hours are noticeable the last fortnight among the jewelers.

In the dissolution of the firm of Smith & Crosby, which went into effect Saturday, April 4, a concern prominently identified with the trade for 34 years undergoes a marked change. Alfred R. Crosby has purchased the interests of his long-time partner, William H. Smith, and will take in as associates his two sons, Alfred D. and George H. Crosby. The concern came into being as the result of the ambition of the two above-named partners, both of whom were at the time employed in the factory of Hodges & Shaw, long since out of existence. The first business style adopted was Smith, Crosby & Smith, the principals being Alfred R. Crosby, William H. Smith and the late Stephen T. Smith. The last named was with the company only some three years, and then left the industry altogether. W. H. Smith has not enjoyed the best of health for 10 years or more, and the burden of the business has been carried by Mr. Crosby. About a year ago retirement seemed advisable in the case of Mr. Smith, and negotiations were opened, but their progress was delayed by many details of settlement until the present time. Mr. Smith, it is understood, will make his home for a time in New York, with relatives. Alfred D. Crosby, older son of the senior partner, has been with the P. J. Cummings Co. until recently, while the younger son, George, has for the past few years been foreman for Smith & Crosby. The matter of the firm name is still under consideration.

W. H. Lynn, Stanley, Wis., will close out a stock of jewelry, which he purchased recently.



The following traveling representatives were in San Francisco, Cal., during the past week: Mr. Brown, Carter, Howe & Co.; Mr. Slemmons, J. B. Bowden & Co.

Traveling representatives in Los Angeles, Cal., recently, included: Morey Meyer, Meyer & Weinschenck; Alex. Feldenheimer, California Jewelry Co.; Joseph Leudan, Katz & Leudan.

Mr. Cohen, representing the California Jewelry Co., was in San Francisco, Cal., for a few days the first of the week, after a satisfactory trip through Southern California. He has since left for the north.

Among the traveling representatives in Lancaster, Pa., recently, were: Harry A. Platt, Rees & Vankauer; D. G. Stites, Aikin-Lambert Jewelry Co.; W. R. Cobb, W. R. Cobb & Co.; Walter J. Ways, McIntyre, Magee & Brown; F. C. D. Bonner, F. & F. Felger.

The following traveling representatives called on the trade in Kansas City, Mo., during the past week: W. F. Drexmit, Keystone Watch Case Co.; Joseph C. Wilson, William A. Rogers, Ltd.; Henry H. Jacobson, Jacobson Bros.; E. A. Moore, Sykes & Strandberg.

Traveling representatives who called on the trade in Omaha, Nebr., during the past week, included: Mr. Harrison, W. W. Harrison Co.; E. C. Binder, Ernest Gideon Bek; J. Mills Dillaway, International Silver Co.; Jul. F. Schuman, Jr., William Kinscherf Co.; G. C. Pugh, Wright-Rich Cut Glass Co.; G. W. Finckenaer, Alvin Mfg. Co.; J. Percy Wrayton, Durand & Co.; W. F. Adams, Simpson, Hall, Miller & Co.; Ira C. Jones, Chas. L. Trout & Co.; W. B. Harris, Joseph Fahys & Co.; N. Hagenaer.

Traveling representatives who called on the Cincinnati, O., trade, during the past week, included: E. G. Fishback, Hamilton Watch Co.; D. Skutch, New Haven Clock Co.; J. R. Smith, Carter, D'Haven & Co.; L. R. Crowley, American Swiss Watch Co.; Joe Beach, Derby Silver Co.; Mr. Miller, Seth Thomas Clock Co.; Mr. Mead, Barber Silver Plate Co.; Wallace E. Welch, Hoyt, Ohrig & Geiger Co.; E. H. Eckfeldt, Eckfeldt & Ackley; Henry Delerson, Henry E. Oppenheimer & Co.; George S. Melville, D. Wilcox & Co.; A. L. Hancock, C. Sydney Smith & Co.; H. R. Blackman, Champenois & Co.; C. Williams, Gorham Co.; George A. Jachum, C. Cornelsen; Emil Piek, Hammel, Riglander & Co.; Arthur Bradshaw, International Silver Co.; F. C. Winship, H. C. Fry Glass Co.; Frank P. Steitz, William Link; J. M. Torbert, Simeon L. & George H. Rogers Co.

Among the traveling representatives who visited the trade at Pittsburg, Pa., last week, were the following: Henry Delerson, Henry E. Oppenheimer & Co.; W. H. Gregory, Strobel & Crane; Harry Goodison, Webster & Son; R. H. Schley, Sloan & Co.; John F. Schierloh, Keystone Watch Case Co.; A. Rutherford, Gibson, Schragler Co.; George S. Melville, D. Wilcox & Co.; A. E. Hayward, Seth Thomas Clock Co.; Arthur Totten, Sansbury & Nellis; J. E. Simonson, Ludwig Nissen & Co.; W. H. Osborne, R. Wallace & Sons Mfg. Co.; M. F. Loomis, C. Sydney Smith & Co.; H. C. Hubley, Geo. Borgfeldt & Co.; J. T. Griffith, Jr., Carter, Howe & Co.; John H. Baker, Jacobson Bros.; George A. Jochum, C. Cornelsen; J. J. Hull, Blackman & Henderson; Mr. Ford, Ford & Carpenter; E. H. Hough, Jennings Bros. Mfg. Co.; H. B. Bliss, Gorham Co.; Walter R. Sheets, Dav. Clark & Co.; Lester B. Smith, Domneck & Haff; William J. Harber, Enos Richardson & Co.; Arthur Bradshaw, Meriden Britannia Co.; R. E. Williams, St. Louis Silver Co.

Louis J. Deacon, Atlantic City, N. J., is now at his Summer headquarters, Cape May, N. J. He is recovering from a severe attack of grippe, and went to Cape May earlier than usual for the purpose of obtaining rest, and will remain for the Summer.

Connecticut.

Robert Wallace, in company with George M. Wallace, of New Haven, left, Saturday, for Panama.

S. H. Kirby & Son, New Haven, have donated \$20 to the Grace Hospital Building Fund, at New Haven.

Morris Lurie, a watchmaker of 216 Oak St., New Haven, was arrested, Wednesday, on a charge of a breach of the peace.

C. R. Wells, of the firm of Wells & Gunde, New Haven, has purchased a parcel of real estate in Elm St., near University Pl.

R. N. Jonnquest has purchased the business of G. F. Matteson, 828 Chapel St., New Haven. He is renovating the store and will install new fixtures.

President Lee Roberts, of the Bristol Business Men's Association, has announced that the annual banquet will be held about the middle of this month.

Frank D. Lobb, for some time foreman at factory "M," International Silver Co., Wallingford, died recently at his home, 22 Wallace St., aged 33 years.

Robert H. Keller, formerly general manager for the J. D. Bergen Co., has resigned and will move to New York, where he was formerly located. Mr. Keller will be succeeded by Thomas Singleton, of Bowling Green, O.

Frederick Hoffman, for a number of years assistant foreman in the tower clock department of the Seth Thomas Clock Co., Thomaston, was promoted Saturday to the office of assistant superintendent of the movement shop.

Joel F. Leete, who died, about a week ago, at his home in Wallingford, at the age of 63 years, was employed at factory "L," International Silver Co., when he first came to that town. Mr. Leete resided in Wallingford for 25 years.

Mrs. John H. Sessions is critically ill at the Winter home of her daughter. Mrs. George W. Neubauer, Sarasota, Fla. Messages were received one day last week by Wm. E. Sessions, a son, indicating that her condition was serious.

Walter Camp was among those present at the dinner at the Crescent Athletic Club, at the club house in Brooklyn, N. Y., March 26. Mr. Camp made a speech advocating clean sport. Mr. Camp's speech created much interest and enthusiasm.

Chas. F. Linsley, secretary of the Bradley & Hubbard Mfg. Co., Meriden, was the recipient of many congratulatory messages, last week, on the occasion of his 65th birthday. Mr. Linsley has been with the Bradley & Hubbard Co. since 1869.

Charles H. Weston, one of the oldest employes of the Waterbury Clock Co., Waterbury, about a week ago died at his home, 81 Burton St., after an illness of eight weeks. The deceased had been connected with the Waterbury Co. for the past 26 years.

Ralph Jacobs, Waterbury, has disposed of his pawn brokerage business and will hereafter devote his entire attention to his jewelry store. The concern has moved from 231 Bank St. to 61 S. Main St., where attractively furnished quarters have been fitted up for his use.

The Aetna Cut Glass Co. has secured spa-

acious quarters in the building owned by the Lewis estate, Meriden, and partnership papers are being drawn for the concern. J. W. Murray, formerly superintendent of the J. D. Bergen Co., is manager and designer for the new firm.

Frank E. Leard, Meriden, drank potassium cyanide while at work at factory "E," International Silver Co., last Wednesday, and died almost instantly. Leard was a Canadian, about 43 years old. He is survived by a widow and a young son. He had been employed at the factory as a burinisher for 18 years.

The annual meeting of the stockholders of the International Silver Co. was held at Jersey City, N. J., last week, and the following directors were elected: George H. Wilcox, Meriden; Andrew Andrews, Wallingford; S. L. Barbour, Hartford; C. L. Tibbits, Wallingford; R. L. Beekman, New York; C. E. Breckenridge, Sr., New York; George M. Curtis, Meriden; George D. Munson, Wallingford; G. C. Edwards, Bridgeport; C. A. Hamilton, New York; H. L. Lewis, Stratford; W. J. Miller, Derby; C. Berry Peets, New Haven; George Rockwell, Waterbury; C. B. Rogers, Meriden; E. P. Wilcox, New York. The annual meeting of the directors for the election of officers will be held in Meriden this week.

Boston.

A. J. Landry & Co., whose lease expires in June, are selling out their stock.

Boston creditors of J. F. Burgess, Camden, Me., have received a dividend of 25 cents on the dollar.

Henry J. Landry, manager, 123 Washington St., the former A. R. Grover establishment, is closing out the stock by a special sale.

Buyers in town during the week included: Frank A. Howard, Rutland, Vt.; William Senter and George T. Springer, Portland, Me.

Edward L. Jerwood, representing Frank Hutchinson, London, who has been in this country for about six months, spent a couple of days in Boston calling on members of the trade during the week, prior to sailing for England.

The second annual banquet of the New England Watchmakers' Club will be held Thursday, April 16, at the American House, Boston. This evening the club will meet at its headquarters, 17 Bromfield St. A synopsis of J. A. Freund's lecture will be read by the president, and general discussion will follow.

Walter G. Hartog, 45 years old, was sentenced, early last week, to two and a half years in the house of correction by Judge De Courcy in the Superior Court, for the larceny of \$2,311 worth of watches, rings and jewelry from a Washington St. house, by which Hartog was employed as salesman for one and a half years. Hartog's territory was Springfield and Holyoke, and when he became involved in his affairs he left the State, sending back his bag with \$2,000 worth of samples missing. He was arrested in Lexington, Ky.

Claiming to have in his possession \$50,000 in diamonds which he had just brought from South Africa, Morris Shipyan was arrested on a charge of assault on Max

Sandberg as the result of a quarrel over the question of the genuineness of the stones. Shipyan came to Boston from New York with his pockets fairly bulging with cut and uncut stones, which he claimed were diamonds he had secured in South Africa. He tried to have Sandberg, who is a janitor, help him dispose of some of them, but Sandberg was suspicious and a quarrel followed which led to Shipyan's arrest.

Canada Notes.

The death of George Henry, Lennoxville, Que., is announced.

T. Samson, Yamachiche, Que., has assigned to H. Lamarre.

James Roy, Port Arthur, Ont., has assigned to John R. Wishart.

E. A. Lapierre, Ottawa, Ont., is offering to compromise with his creditors.

John Wenger, Victoria, B. C., was in Toronto, Ont., last week, on his return trip from Switzerland.

W. H. Sproule, Ottawa, Ont., has made an assignment to C. M. Farley, and a meeting of creditors was called April 7.

The store of G. F. Dey & Co., Finch, Ont., was entered by burglars one night recently. They broke a large plate glass pane in the main entrance and secured 15 watches, a number of chains and rings and \$30 in cash.

Joseph Lane's jewelry store at Brockville, Ont., was robbed on Monday night, March 30, the burglars entering through a back window. They carried away about \$500 worth of goods, including 12 gold watches and 13 diamond rings.

Out-of-town jewelers calling on the Toronto, Ont., trade last week, included: H. Hercher, Bobcaygeon; W. E. Irvine, Orangeville; Nelson McLeod, Cannington; W. E. Kelly, Goderich; W. Ashcroft, Warton; George T. Wehrley, Harriston, and J. L. Bert Wilson, Woodstock, all Ontario.

Ryrie Bros., Ltd., Toronto, Ont., are making an extensive addition to their establishment, having secured the premises immediately west, which will be fitted up for the accommodation of their cut glass and art goods departments. When the alterations are completed it will give them about 4,000 feet additional floor space.

On Thursday, March 26, a fire broke out in the building occupied by A. Rosenthal & Sons, Ltd., Ottawa, Ont., in the upper part of the building, temporarily occupied by Jenkins Bros., with a stock of bric-a-brac, antique goods and art curios, which they had been selling off by auction. The flames were got under control before they reached the Rosenthal store below, but the stock sustained much damage by water. Jenkins Bros.' loss is estimated at \$30,000, with \$20,000 insurance, and that of Rosenthal & Sons at \$5,000 on the stock and \$5,000 on the building, both covered by insurance.

W. H. Rowton, who for many years held a responsible position with the R. J. Riles Co., Jacksonville, Fla., recently purchased the jewelry store of R. N. Dickey, 104 Main St., and as member of the firm of Wm. H. Rowton & Co. is conducting business at Jacksonville, at that address. The new firm contemplates making many improvements.

Providence.

Wilkinson & Co. have purchased the plant of the Babcock Jewelry Co. at 38 Friendship St., and will make their plated goods in that shop.

A regular quarterly dividend of 4 per cent. has been declared by the Gorham Co. on its preferred stock. The dividend is payable on April 1.

Alfred C. Noyes, who has been engaged in the die sinking and designing business at 101 Sabin St., this city, has removed to Taunton, Mass., to engage in the same line of business.

Arthur C. Sylvester, who has been foreman in the Geo. W. Parks Mfg. Co., has gone into partnership with Samuel L. Slocomb at Plainville and will do business in

the future as a member of the firm of the United Brush Co.

A disastrous fire in the Billings building on Tuesday morning wiped out the shops of Warren & Williams and threatened for a time the larger plant of Hamilton & Hamilton, Jr., in an adjoining building. Harry Cutler came to the rescue of Warren & Williams and fitted up an emergency telephone office in his shops for the damaged firm.

According to the report of the factory inspector presented to the General Assembly, the jewelry trade is not in such a bad way after all. The figures compiled by the inspector were gathered before the period of business depression in October last. These figures, take as a basis for a calculation, present conditions show that

there are at least 5,000 persons who depend on the jewelry business in this city alone for a living. The Gorham Co., with 1,889 operatives, is the largest concern, while Ostby & Barton Co. comes next with 790 employes. In the gold trade it is found that the most hands are employed and curiously enough it is discovered that this line of work is doing the biggest business just at the present time. The cheap jewelry shops are still running overtime in many cases and all along the line the factory inspector finds that trade, while it may not be said to be booming, is nevertheless picking up.

Harrisburg, Pa.

Rubin & Rubin, Market St. opticians, have inaugurated a uniformed messenger service.

L. D. Cook & Bro., Mechanicsburg, have removed their jewelry store a few doors west of their old location in that town.

The Chazm Jewel Co., which did considerable business in the line of cheap jewelry on Market St., has closed out the business here and removed its stock to Baltimore.

Cohen Bros., who have stores in this city, York, Reading and Trenton, N. J., have leased Nos. 11 and 12 rooms at No. 7 N. Center St., Pottsville, and opened a jewelry and optical establishment there.

Jacob Tausig's Sons, Market St., published a communication in the *Daily Telegraph* last week regarding the inquiries they had received relative to the depreciation in the price of diamonds.

More of the goods stolen from the jewelry store of Archie K. May, in York, have been found. Detective White secured three of the finest of the stolen rings from the gutter across the road from the home of David Saeger in Pleasureville. Saeger was recently arrested in connection with this robbery, and admitted throwing away a package of jewelry.

Charters have been granted at the State Department to the following stores: Hausmann & Co., optical manufacturers, Philadelphia, capital, \$5,000; directors, Otto G. Houssmann, president; Norma Houssmann and Frederick W. Houssmann Par-Sil Metal Co., Glenside, capital, \$25,000, manufacturing plating of all descriptions; directors, Chas. E. Swartz, president; David B. Flower, Thos. M. Byrne, Chas. W. Wade, C. Lester Taylor, Edgar S. Nash and Henry Struntz.

York's newest industry, the Pennsylvania Watch Case Co., formerly the Southern Watch Case Co., of Nashville, Tenn., has taken out a charter at the State Department. The capital stock is \$150,000 and the directors are: Chas. Lattes, Nashville, Tenn., president; W. Huel Walling and Orpheus E. Bell, Nashville; John W. Steocy, Jno. Fahs and Geo. P. Snuyser, York. Other incorporators are: William H. Landis and William P. Swartz, of York. Of the 1,500 shares of stock, Director Bell holds 750 shares, and directors Walling 400 shares, and Lattes 20 shares. The company has taken out a permit to remodel the interior of the property of the York Dentists' Supply Co., at Penn St. and Clark Alley. Four carloads of special machinery have arrived and will be installed.

THE "HOLDWELL" COLLAR and BOW PIN

50 designs, 3 sizes, for small, medium and large bows.

To retail at from 50c. to \$1.50.



ON THE BOW



FRONT

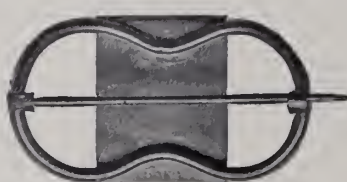

BACK

A Seasonable Novelty.

Holds the bow without defacing it, and securely pins the collar. The bow is easily inserted from the back. Simply open pin tongue, and slip ends of bow through wire loops one end at a time. The popularity of ladies' bow ties makes its sale assured.

TO THE WHOLESALE TRADE ONLY.

Send For Samples At Once.

E. A. POTTER COMPANY

Providence, - Rhode Island

Philadelphia.

Col. John L. Shepherd, New York, was a visitor to this city last week.

Katz & Kardon have taken over the business of Julius Kling, at 501 Girard Ave.

George W. Fisher with L. P. White, is convalescing from a fractured arm, sustained in a fall.

Trading as Goldstein & Gross, a new gold and silver plating establishment was started last week at 514 Pine St.

J. B. Bechtel, of Joseph B. Bechtel & Co., 725 Sansom St., is away on an extended trip of the Schuylkill Valley.

F. B. Wallen, 405 Broadway, Camden, has returned from a short vacation spent at his parents' home in Bridgeport, N. J.

Nathan Halpert, manufacturer of gold chains and bracelets, has removed from 517 Lombard St., to more spacious quarters at 514 Pine St.

The stock and fixtures of the retail store of Naum Rosenbaum, bankrupt, 19 S. 9th St., are to be disposed of at a receiver's sale tomorrow, April 9.

The Franklin Fountain Pen Co., 10th and Arch Sts., was visited by thieves last week, who were frightened away before they could obtain any plunder.

Louis J. Schelle, formerly with S. C. Levey, 2314 Columbia Ave., has purchased the jewelry and optical establishment of Charles L. Conrad, of 609 Girard Ave.

George W. Jacobson, formerly traveling salesman for S. Jacobson, will open a new jewelry store, about April 15, in the premises formerly occupied by M. Rosenbaum, at 316 N. 8th St.

H. Lichtenstein, retailer, formerly of Lebanon and Williamsport, Pa., opened on the first of the month, a new store in Coatesville, Pa., occupying the store vacated by F. H. Ewald.

It is announced that no more silver is to be bought for the Philadelphia Mint until after the close of the fiscal year, June 30, as the stock on hand is reported to be sufficient for all needs till that time.

W. R. Cobb, manufacturer of jewelers' findings, Providence, R. I., stopped off in this city, last week, on his way home from a sojourn for rest and recreation in Florida and various southern resorts.

James Blisard, of John F. Blisard & Co., 727 Sansom St., returned, Saturday, from a trip through the eastern shore district of Maryland. The firm, last week, added a new large burglar-proof safe to the office equipment.

James McMillan, of the material department of M. Sickles & Sons, is convalescent after an operation performed for the removal of a fistula. Sol. Sickles, of the firm, has gone for an extended trip throughout Pennsylvania.

S. Jacobson is concentrating his business at 304 Market St., where he has been located since 1893. The stocks of the stores at 302 and 304 N. 8th St. will be removed to Market St. and the establishment given a thorough refurnishing.

John Johnson, a Passyunk Ave. retailer, widely known to local watchmakers, who enjoys the distinction of being the father of 23 children, moved, Wednesday last, to Darby, Delaware County, Pa., where he has a cosy little homestead.

W. P. Sagebiel, optician, 2412 Ridge Ave., has just opened another establishment at 1827 Columbia Ave. The new store is elegantly fitted up and is in a very busy neighborhood. Mr. Sagebiel will make his headquarters at the new place.

Charged with obtaining merchandise by false pretense, valued at \$2,000, from the Keystone Glassware Co., 1226 Mascher St., two brothers have been held in \$1,500 bail by Magistrate Scott. The police are still seeking for another brother of the prisoners and an alleged co-conspirator.

F. H. Ewald, Coatesville, Pa., who has leased and attractively equipped a new store opposite the one which he has occupied for years, expects to move into it soon. Harry L. Ewald, formerly associated in business with his brother in Coatesville, has opened a store of his own at Mount Jewett, Pa.

Among the retailer jewelers visiting the city, last week, were the following: George W. Hamilton, Altoona, Pa.; H. S. Landis, Frederick, Md.; Josiah Heckler, Mainland, Pa.; David Krause, North Wales, Pa.; W. Caldwell, Wildwood, N. J.; H. B. Shanely, Quakerstown, Pa., and Wm. Beck, Vineland, N. J.

George W. Leopold, of the traveling staff of H. O. Hurlburt & Sons, departed last week for a business trip to Washington and Baltimore. William H. Dawson, of the inside force, who has been critically ill for three weeks with inflammation of the stomach, has sufficiently recovered to be able to resume his duties again.

A clerk in the store of A. F. Pinkstone, 1947 South St., last week detected a colored man in the act of pilfering a diamond ring from a tray which was being shown him and gave chase. The man was arrested and the ring recovered. He gave his name as James Moore, 16th and Lombard Sts. He was held in \$800 bail for court.

The limited partnership of J. E. Caldwell & Co., 902 Chestnut St., having expired the members of the firm have renewed the agreement to be continued until March 31, 1911. The general partners are J. Albert Caldwell, J. Frederick Thomas, Edward T. Chase, William R. Eisenhower and James E. Caldwell. Joseph H. Brazer is special partner.

Boris Oster is no longer connected with the establishment at 2134 N. Front St., having sold the fixtures and part of the stock to Frank Witaskis. Mr. Oster will confine his attention in future to his establishments at 1910 Germantown Ave. and 1719 Sansom St. Mr. Witaskis is fairly well known in the trade and will undoubtedly infuse new life into the Front St. store.

Isadore B. Broveman, trading as the Keystone Jewelry Store, Reading, Pa., was adjudged a voluntary bankrupt last week in the United States District Court. Samuel E. Bertolet was appointed referee. The liabilities are stated to be \$3,645.32 and the assets \$320. The larger creditors are wholesale dealers of this city. Broveman was a frequent visitor to this city's trade.

J. E. Caldwell & Co. displayed last week a handsome silver loving cup especially designed by the firm for the Quaker City Motor Club "readability" run, under sealed orders, from the Hotel Walton to the Hotel Cape May, Cape May, N. J., on Saturday next. It is known as the Hotel Cape May

Cup, and a clever etching of the new hotel with a view of the boardwalk, beach and bathers adorns it, while at the base is the insignia of the Motor Club.

The Business Association of Pennsylvania, an organization whose object is to accomplish the repeal of the Mercantile Tax Law, which imposes taxes on the amount of business done by all retailers throughout the State, has been incorporated and granted a charter. The imposition of the tax, together with the necessity of merchants opening their books for the inspection of agents, has been bitterly opposed by leading jewelers of this city and State.

The trade of this city read with regret the note last week in THE CIRCULAR-WEEKLY of the death of Joseph Landis, a watchmaker, at one time a prominent retailer of Doylestown, Pa., but of late associated in business with his son, A. H. Landis, a retail jeweler of Lansdale, Pa. Mr. Landis was buried March 24. He was over 70 years old, and in his day had been an active watchmaker and a progressive merchant. He was well known throughout the State. Of late years he has lived in semi-retirement with his son.

The Seth Thomas Clock Co., New York and Thomaston, Conn., is holding a special exhibition of its products at the House Furnishing Show, Horticulture Hall, which opened Monday and will continue until Saturday. The line includes cabinet clocks, glass regulators, fancy bronze clock sets, with figures and candelabra, and an especially fine display of the adamantine line in which clocks are shown in white as well as golden bronze, mottled green and mahogany finishes. A fine line of alarm clocks is also displayed. The local agents of this company are the G. S. Lovell Clock Co., 18 S. 10th St., and B. J. Cooke's Sons, 137 N. 3d St.

To recover one-third share in the \$30,000 estate left by Gustave C. Kunz, a retail jeweler, who died Aug. 13, 1899, Mrs. Pauline Borchers finally brought to an end, last week, her suit against Mrs. Regina Kunz and the latter's children and now awaits the decision of Judge Bregy, before whom the case was tried. Mrs. Borchers declared that she always believed the jeweler to be her father, but that after his death his other children announced that she was only his stepdaughter—the child of a couple named Bechtold, who were divorced in Germany 40 years ago. Kunz subsequently married Mrs. Bechtold, the mother of the claimant. In his will he bequeathed Mrs. Borchers \$300, describing her as "my adopted daughter, Pauline Bechtold." But Mrs. Borchers contends that she is a daughter of the deceased, and consequently entitled to share in the estate as have the other children of Kunz.

Berthold Block, in the Builders' Exchange, Buffalo, N. Y., received a letter recently postmarked Indiana, which contained \$35, which amount the writer stated was his third of \$100 worth of jewelry which belonged to Mr. Block, but which had one time been lost or stolen. He said he sent it as a "conscience" fund. Mr. Block said he did not remember losing the \$100 worth of gems and cannot account for the act of the writer.



GNTERPRISING and successful jewelers everywhere are pushing the sale of some individual line of watches which they believe to be superior to all others, and upon which they can also make a satisfactory and justifiable profit.

This explains the growing demand for **ILLINOIS WATCHES**, in 0, 12, 16 and 18 sizes, by increasing numbers of leading jewelers throughout the United States.

If you are not familiar with the superior quality of—and advantages gained by handling—Illinois Watches, it will mean reputation and dollars for you to investigate.

Every one fully guaranteed.

Price List sent on application.

ILLINOIS WATCH COMPANY

SPRINGFIELD

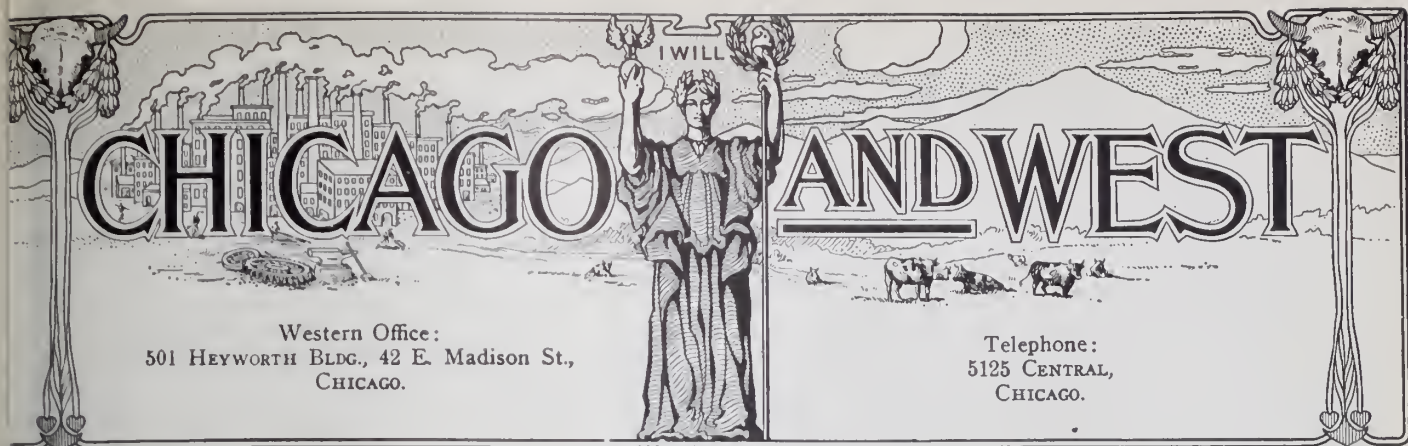

Western Office:
501 HEYWORTH BLDG., 42 E. Madison St.,
CHICAGO.

Telephone:
5125 CENTRAL,
CHICAGO.

Chicago Notes.

Geo. H. Thomas is on a trip through the Middle West.

R. L. Moorehead, Providence, R. I., was here last week.

C. G. Breitenbach made a trip to St. Louis last week.

"Lee" Wechter has returned from a trip to the southwest.

Mr. and Mrs. Oscar C. Cobb, Iowa Falls, were here last week.

Edward Lehman, Denver, Co., was a visitor to this city last week.

Benj. Allen and B. C. Allen have returned from a trip to California.

W. E. Hayward, with the Alvin Mfg. Co., is on a two weeks' jury term.

Leland Stanford, with the Alvin Mfg. Co., is on a trip to the northwest.

O. A. Starke, of the Star Watch Case Co., spent two days here last week.

F. S. Newcomb, with the M. S. Fleishman Co., is back from the northwest.

M. H. Cowen, with Rettig, Hless & Madson, left for the far west last Saturday.

Frank S. Fisher, Danville, Ill., was here last week buying fixtures for his new store.

H. E. Glendore, jewelry auctioneer, is making a sale for Daniels Bros, Denver, Col.

The affairs of Conrad Heegn, Jr., bankrupt, have been referred to Referee Eastman.

Chas. A. Garlick, representing Reeves & Browne Co. and Chas. F. Wood & Co., is here.

L. M. Levy, sales manager for the Philadelphia Watch Case Co., was here last week.

Chas. E. Hancock passed through this city last week on his way home from the Pacific coast.

Theo. Jacobs & Co. have removed from the fourth floor of the Silversmiths' building to the second floor.

Arthur Lack, with Bullara Bros., St. Paul, Minn., has been ill for some time at the Chicago Athletic Club.

Larry Edwards will represent the lines of Furbish, Swift & Fisher and Leach & Miller, for the coming season.

Everet I. Rogers, of Parks Bros. & Rogers, was here all last week in connection with the affairs of F. C. Happel & Co.

J. S. Richter has given up the line of O. Sweet & Son Co. and is now in Providence making arrangements to represent some new lines.

M. B. and H. H. Joseph, representing Wildpret & Saacke and Wolstenholme Mfg. Co., have removed from 185 Dearborn St. to room 1516 Heyworth building.

The Oro Mfg. Co., Ashland Block, has been incorporated to manufacture jewelry with a capital of \$10,000. The incorporators are: Charles R. Brown, Charles Martin, H. M. Buall.

Two thieves entered the place of business of M. A. Eiseman & Bro. last week, and one of them stole a few articles of jewelry. He was caught and the jewelry recovered. His companion escaped.

The first meeting of the creditors of the Shourds, Adcock, Teufel Co. will be held at room 905 Monadnock block, April 14, at 10.30 A. M. A trustee will then be elected. The stock has been appraised at \$45,000.

John C. Hirt, father of Carl Hirt, with the Juergens & Andersen Co., died last week at his residence, 617 Wells St., and was buried on Wednesday. The trade extend their sympathy to Mr. Hirt in his bereavement.

"Ben" Sandfelder, for 10 years with McRae & Keeler, has severed his connection with that concern and in future will represent M. W. Carr & Co., West Somerville, Mass. Mr. Sandfelder will reside in Chicago and cover his old territory.

Miss N. Adella Farquharson, sister of Harry E. Farquharson, died last week after an operation for appendicitis at the Post Graduate Hospital, and was buried at Rosehill Cemetery. Mr. Farquharson has the sympathy of the entire trade in his sorrow.

A despatch from St. Paul last week stated that A. T. Niswanger, traveling salesman for a Chicago jewelry house, was robbed of his grip in the Union depot, that city, March 28. Mr. Niswanger reported to the depot officials that the grip contained a quantity of samples.

Among the buyers here last week were George Greenwood, of Fish & Greenwood, Reedsburg, Wis.; H. J. Crawford, Marseilles, Ill.; C. C. Bacon, St. Charles, Ill.; W. W. Bugg, Jackson, Mich.; S. P. Giddings, Sterling, Ill.; Everett B. Lewis, Dwight, Ill.; A. L. Lemmon, Guthrie Center, Ia.

I. M. Radabaugh, secretary of the American National Retail Jewelers' Association, has called a meeting for the organization of the retail jewelers of Illinois at the Great Northern Hotel, for to-morrow (April 9), at 2 P. M. A banquet will be tendered the

visiting jewelers by the Chicago Jewelers' Association in the evening.

Someone tried to rob the A. C. Becken Co. of a pair of diamond ear screws last Wednesday afternoon. A telephone message supposed to come from Fred A. Hegner, Blue Island, Ill., said that Mr. Hegner would send his niece, Miss Henderson, for a pair of diamond ear screws of a certain catalogue number, price \$225. Mr. Becken, who talked with the supposed Mr. Hegner over the phone, was asked to tell Miss Henderson to go to the Boston store and get a pair of shoes for Mrs. Hegner. A half hour later "Miss Henderson" appeared with a letter and check for \$200 made out by Samuel C. Crow. Underneath this signature was stamped the words, "Works Office Manager." The check was made payable to Hegner and bore an endorsement which closely imitated his signature. The letter was written on plain paper and requested the Becken Co. to deliver the ear screws to Miss Henderson in a sealed package; to accept the check in part payment therefore and to charge the balance to Hegner's account. The transaction looked suspicious and "Miss Henderson" was told to go to the Boston store, do her shopping and come back for the diamonds. She did not return. Hegner was telephoned to and pronounced the letter a forgery. "Miss Henderson" is described as about 23 years old, five feet four inches in height, and slender in build. She is a brunette, is fairly good looking and wore a suit of red cloth.

Denver.

Mr. Powers, of Eisenstadt & Co., called on the trade here, last week.

M. Bauman, of M. Bauman & Co., has been in this city, for a few days.

L. Wolfsheim, of Wolfsheim & Sachs, accompanied by his wife, spent a few days in town, last week.

Whit. Colyer, of McConnell, Colyer & Co., called on the trade here, last week, this being his first visit to Denver.

Out-of-town buyers who visited this city during the past week were: Wm. P. Jones, Ft. Lupton, Colo., and J. W. Edmonds, Grand Junction, Colo.

Charles Link, a brother of Frank Link, of this city, was shot and killed one morning recently by the accidental discharge of a shotgun while on a hunting trip near Barr, Colo.

We Can Furnish You a Catalog of Your Own



Store of E. L. ALLEN, Trinidad, Colorado.

That will make a big
Increase in your business
And give your store
That high prestige
Not obtainable otherwise.

Read the letters

(Extracts from letter.)

TRINIDAD, Colo., Jan. 8th, 1908.

THE ARNSTINE BROS. COMPANY,

Cleveland, Ohio.

GENTLEMEN: We have no reason to complain of the financial depression, for our Holiday business doubled itself over last year and we feel a great deal of this is due the Catalogs, as we heard from them more than ever before. Very truly yours,

E. L. ALLEN.

(Extracts from letter.)

BOISE, Idaho, Jan. 17th, 1908.

THE ARNSTINE BROS. Co.,
Cleveland, Ohio.

GENTLEMEN: In reply to yours relative to the use of the Catalogs will say that I am more than satisfied with them. This is the second year that I have used them and I must say that they certainly bring business.

Last year they increased my December business very materially, while I anticipated a large decrease on account of the money stringency.

Wishing you the success you well merit, I am,

Yours truly,

CON. W. HESSE.



Store of CON. W. HESSE, Boise, Idaho

Write us at once for samples and particulars FREE

Our representatives visit nearly every State in the Union. If you are interested, and will notify us, our representative will take pleasure in calling on you and explaining our method.

THE ARNSTINE BROS. COMPANY

Originators of Our Exclusive Catalog Method for the Retail Jeweler

CLEVELAND, OHIO

IN WRITING US, PLEASE MENTION THIS ISSUE, "JEWELERS' CIRCULAR-WEEKLY"

Kansas City.

Leslie McKee has taken a position as watchmaker for G. A. Esslinger.

L. J. Keis, Quincy, Ill., recently finished a course in optics in this city and has returned home.

W. C. Schumann, with the C. B. Norton Jewelry Co., has just returned from a trip through Arkansas.

A. E. Pitenger has returned from a sojourn at Excelsior Springs, where he has been for the benefit of his health.

C. E. Manor has returned from Lawrence, Kans., where he has closed a successful auction sale for B. G. Gustafson.

S. C. Lee, who has been with the C. B. Norton Jewelry Co. for some time, has gone with the Green Jewelry Co., as engraver.

W. E. Crellin, of the Ward & Crellin Jewelry Co., has just returned from a trip over his territory, and leaves for the road again, next week.

All the traveling representatives of the Edwards & Sloane Jewelry Co. will begin working in next week, so they can help take inventory, April 15.

H. R. Carroll, Oklahoma City, Okla., and Guy Wilhite, Adrian, Mo., are new pupils just enrolled at the Kansas City Polytechnic Institute.

W. J. Mulnix, King City, Mo., who was here last week, bought an opening stock of jewelry and new fixtures for a store which he is opening at that point.

J. V. Robinson, of the C. B. Norton Jewelry Co., has just returned from a short trip to the larger near-by cities in Kansas, in the interest of their material department.

Fred Chamberlain, who has been with J. R. Mercer, has resigned to devote his entire attention to the real estate business in which he has been interested for some time.

C. P. Kionka, of Kionka & Kionka, left last week for a trip over his eastern territory. His wife also left the city last week to spend Easter visiting her brother in Milwaukee.

Chas. Knaul and Chas. Cleveland, traveling representatives with the Woodstock-Hoefler Watch & Jewelry Co., were in this city last week, laying in a new stock. They started out again this week.

C. L. Farnsworth, Kansas City, Kans., who has been seriously ill, of typhoid-pneumonia, is again able to be around and attend to his regular duties. His illness has left his eyes badly impaired.

S. E. Woodstock, of the Woodstock-Hoefler Watch & Jewelry Co., has returned from Clear Lake, Ia., where he has been enjoying a visit with his brother. He also paid a visit to their regular representative in that territory, Al. Wells, who has been quite ill.

J. L. Potts, of the Potts Jewelry Co., Marceline, Mo., was in this city last week. The firm name was changed from J. L. Potts to the Potts Jewelry Co., recently, his sons having engaged in business with him. New fixtures have been installed in the store, including five wall cases and eight modern show cases.

Louis and Michael Oppenstein, of the jewelry firm of Oppenstein Bros., have just invested in the property at the southeast

corner of 12th and Walnut Sts., and state that after present leases expire, one year from now, they will erect an office building there. The purchase price was \$211,750, being \$5,500 per front foot.

The following jewelers were in this city last week: C. A. Clement, Springfield, Mo.; E. D. Martin, Carl Junction, Mo.; W. R. Pearce, Gardner, Kans.; J. B. Vannoy, McLean, Tex.; Frank G. Mitchell, Marshall, Mo.; Geo. W. Killiam, Pittsburg, Kans.; Mrs. B. M. Wiard, Concordia, Kans.; John Thorson, of Anderson & Thorson, Wahoo, Nebr.; G. J. Hanson, Council Bluffs, Ia.; W. S. Noble, Drexel, Mo., and L. D. Willitt, Hiawatha, Kans.

Cincinnati.

Hugo Lindenberg, of Lindenberg & Fox, is making a six weeks' business tour of the southern trade.

A. M. Plaut, manager of the National Jewelry Co., is calling on his friends in the south this week.

G. Spiegel, of A. A. Spiegel & Co., was kept from his road trip, last week, on account of illness.

Charles W. Hickok, of Graff, Washburne & Dunn, is reported as improving slowly from his recent illness.

A. F. Harting, Lexington, Ky., stated to Cincinnati friends, last week, that he is closing out his business permanently.

Schmidt & Bloesing, watchmakers, 14 E. 4th St., after April 15, will be located on the eighth floor of the Union Trust building.

Sig. Strauss, of Lindenberg, Strauss & Co., is combining business and pleasure for a few weeks in New York. S. Sommers, of this firm, has just returned from a pleasure tour of Florida.

Jacob Morris, for the past three years located on upper Vine St. and for about seven years previous to that located near 6th and Vine Sts., has discontinued his business permanently and become associated with Bingaman & Co., at 6th and Vine Sts.

Fred Pieper, Covington, Ky., has torn out the rear wall of his store, which he is extending about 30 feet. He also contemplates installing new cases and adding extensively to his lines, which will make his store, when completed, one of the finest in that section.

The local Retail Jewelers' Association met Tuesday afternoon, March 31, to make further arrangements for the coming convention. During the meeting the subject of jewelry peddlers came up and a committee was appointed for the purpose of seeing what can be done toward eliminating this business.

John Holland, president of the John Holland Gold Pen Co., last week recovered sufficiently from his recent attack of illness in Chicago, to return to Cincinnati, accompanied by his wife. It is now expected that the Holland plant, which recently suffered by a fire, will be entirely repaired and that Mr. Holland will be at his desk again in a short time.

Julius Hutmacher, a jeweler, who was recently arrested on charges preferred by the proprietor of the Musical Exchange Café, Vine St., is awaiting trial, having been bound over to the Grand Jury. Hutmacher came here about six months ago from New York, and has been working in

the different jewelry factories. A short time ago it is alleged that Hutmacher attacked the complainant, whom he chased into a hallway on upper Vine St., and was beating him when the police arrived. The object of the attack is not known.

Cleveland.

H. F. Hurlbut, of the Scribner & Loehr Co., who has just come in from a trip, starts out again at once.

E. H. Barrett, of the Wingate, Nusbaum Co., was recently called to Angola, N. Y., by the death of his sister.

Mr. Ulmer, representing the Kryptok Sales Co., New York, was in town Wednesday and Thursday of last week.

H. W. Arnstine and B. V. Arnstine, of the Arnstine Bros. Co., who have just come in from recent trips, state that they find the demand for first class catalogues excellent everywhere.

"Ball's Time" is evidently in great demand in Cleveland. Figures recently compiled by their exchange operator indicate that the Webb C. Ball Watch Co. receive 1,000 requests per week for correct time.

W. H. Saxton and J. W. Dutton, assistants to Webb C. Ball, are installing a time service system for the Boston & Albany Railroad Co. This will put Mr. Ball's system in uniform operation over the entire mileage of the Vanderbilt lines.

The firm of Miller & Bauer, wholesale jewelers and diamond dealers, 402 Garfield building, has been dissolved by mutual consent, Mr. Miller retiring. Mr. Bauer, who liquidates with the old firm, assumes all the liabilities, and all bills payable to the firm will be collected by him.

The following dealers were in town during the past week: E. E. Critz, Elyria; E. H. Holter, Canton; L. J. Goddard, Ravenna; H. H. Brainard, Medina; C. J. Duncan, Massillon; A. P. Humphreys, Bellefontaine; Geo. F. High, Medina; F. B. Montgomery, Sandusky; C. E. Ennis, Wakeman; A. E. Kintner, Painesville; J. L. Miller, Middlefield; W. J. Higgins, Shelby; E. D. Davis, Kent; Wm. Kutz, Bellevue.

Judge Hadden, of the Probate Court, has been asked to determine disposition of the business, processes, tools, etc., of Wm. Pugh, who recently conducted a jewelry store on E. 66th St. Mr. Pugh had perfected a formula for making eyeglasses used especially by blast furnace workers and in great demand wherever open-hearth steel is manufactured. His wife lately took up this business and had been supporting herself and son thereby, until Geo. W. Kinnard applied for guardianship of Pugh, alleging that his tools and business were going to ruin.

A display made by the Illinois Watch Co. in the windows of the Cowell & Hubbard Co.'s store has attracted a great deal of attention, crowds thronging in front of the store for the past week. On a frame several feet in diameter, cut watch shape, several hundred Illinois watches, running, form an attractive background. The body of the window is generously supplied with wheel stampings, jewel settings, screws, jewels, unfinished plates, etc. Inside a representative of the Illinois Watch Co., in charge of the exhibit, made explanation to all interested.

SWARTCHILD & COMPANY

HEYWORTH BUILDING

CHICAGO

The Largest Exclusive Jewelers' Supply House in the World



NEW GAS SOLDERING TOOL

Copper, which is continually over the flame, is adjustable.

FITTED WITH STOP-COCK

Tool is 9 inches long and is made with Wood Handle and Brass Trimmings.

No. D 19. Tool 9 inches, copper length, 1½ inches, each - \$1.75
 " D 20. " 9 " " " 2¼ " " 2.00

Every Jeweler must appreciate the practicability of this tool.

The Genuine HOLD-ON

SCARF PIN PROTECTORS

AT A REDUCED PRICE \$2.50
 No. 78000 Per Dozen

If you have not a copy of our double-sized, 440-page Catalogue, write at once. Sent gratis upon application.

Pat. May 20, '02



306

S. PITZELE

Established 1893

51-53 Maiden Lane, New York

MANUFACTURER OF

FINE DIAMOND MOUNTINGS

Also BRACELETS and DWT. GOODS

SPECIAL ATTENTION GIVEN TO ORDER WORK



218



325



435



Chicago Art Metal Works

Manufacturers of

INITIALS and MONOGRAMS

FOR PURSES, BAGS, BRUSHES, ETC.

Monogram Fobs and Belt Buckles

Write for Catalogue and Prices

63 Lake St., Chicago, Ill.

R I B B O N S

plain and fancy designs Made to Order, in large or small quantities, to use with medals and for club purposes. :: :: :: Correspondence invited.

JOSEPH LOTH & CO., Manufacturers, 65 Greene Street, New York

Established 1880

DAN I. MURRAY

Maker of the Largest Sales ever made in America

Mr. Jeweler, why do you go into bankruptcy and disgrace yourself and family when you know there is a man with three good expert assistants to sell your store out completely at 100 cents on the dollar? Mr. Jobber, why do you take 25 cents on the dollar to settle your claims against retail jewelers who are not able to pay more when you know that I get 100 cents and over on the dollar in conducting auction sales?

I will tell you why. You are living in the dark ages in this part of your business; you should wake up at once; write me for my proofs of the sales I conduct. I have the cost of every piece of goods sold and what it sold for, showing profits—a perfect record of my sales every hour. You can have the proofs if you will take the trouble to write me at any of the following offices.

My addresses are

3 Maiden Lane, NEW YORK; 151 Wabash Ave. CHICAGO
 or 512 Race St., CINCINNATI, O.
 also 1172 Sutter St., SAN FRANCISCO, CAL.



DAN I. MURRAY



H. T. STAPLEFORD

One of my expert assistants, a man with 30 years' experience

Detroit.

John Turck, Wayne, Mich., was in the city, last week.

Wm. T. Blashill, Oxford, Mich., visited this city last week.

Walter Mason, Mt. Clemens, was a purchaser in this market, recently.

Henry Hartman, Sebawaing, Mich., was here on a purchasing trip, a few days ago.

Louis Melm, formerly with J. H. Schwegerler, is now in the factory of the Detroit Jewelry Mfg. Co.

A. D. Race, formerly with Wright, Kay & Co., has taken a position as engraver with Willis & Tomlinson.

Ed. Boehm recently returned from a trip to New York, where he attended a secret society convention and was made official jeweler.

A meeting of the creditors of Samuel Stern, who left here suddenly, some time ago, will be held April 14 in the office of the referee in bankruptcy, Harlow P. Davock.

George Matthews, who has been for a number of years with W. A. Sturgeon & Co., in charge of the sterling silver department, has taken a position with John Kay & Co.

Some of the Detroit wholesale jewelers are interested in the disappearance of R. F. Kohli, Columbus Grove, O., as he was a purchaser here. They expect to share with other creditors in the proceeds from the sale of the stock.

Albert H. Christiansen, who has been in charge of a department with W. A. Sturgeon & Co. for a number of years, has taken charge of the correspondence business of B. Siegel & Co. He is a former New Yorker, but has become a well-known figure in the Detroit jewelry trade.

The sale of W. A. Sturgeon & Co.'s stock, which began Monday, has been attracting considerable attention. As the stock is valued at about \$300,000, it is stated that the auction is the largest of the kind ever held in this territory. Jas. H. Hand, New York, is conducting the sale.

An event of more than usual interest is the decision of Petz & Thiry to give up their store at 22 Monroe Ave. This location has been used as a jewelry store for nearly 50 years, and was a landmark in the trade. The firm has disposed of its lease and will move out, May 15. A sale has been begun to close out the stock. It is not yet decided whether the concern will be continued in another location.

The Jewelers Board of Trade was invited to attend a dinner at the Hotel Tuller, Tuesday evening, of last week, given by the trade promotion and entertainment committees of the Wholesalers' Association. The hardware dealers are also on the list. This meeting was held to consider plans prepared by the wholesalers for the entertainment of merchants who come to Detroit on the buyers' excursion, Aug. 10 to 15. The idea is to provide novel and attractive entertainment which will induce a large number of dealers to come to this market, at that time.

Two jewelers have been important witnesses in a local murder case in which the crime was committed for the purpose of robbery, and the plunder taken consisted

chiefly of small diamonds. Percy Bowin is on trial for killing Mrs. Cornelia Welch Jan. 3. Otto Kersten, a jeweler employed by Barnett Werbe, Michigan Ave. and Wayne St., gave the police the evidence necessary to procure a confession from Bowin by identifying the youth as one who had shown him a diamond shortly after the murder and asked him the value. Edmund T. Stevens, a Buffalo jeweler, testified that Bowin had sold him a diamond for \$25 in Buffalo. As the diamond has been identified as the property of Mrs. Welch, the case is likely to be decided chiefly on the testimony of these two witnesses.

Los Angeles.

Berthold Lissner, Oakland, is here with his wife for a short visit.

Ed Turner, of the E. W. Reynolds Co., is making a business trip through Arizona and Nevada.

Will S. Pitt, formerly in the jewelry business in Oelwein, Ia., is spending a month in Los Angeles and vicinity.

A. E. Baranger, of the E. W. Reynolds Co., has returned from a northern trip and is traveling through the southern part of the State.

As yet no clew has been found to the burglar who robbed the window in the store of H. B. Crouch, corner of Broadway and Mercantile Pl.

The new iron front for the Montgomery Bros.' store at Fourth and Broadway is entirely in place and work on the interior is being pushed rapidly.

Among the out-of-town jewelers who visited Los Angeles recently were: F. E. Wolfarth, Covina; J. H. Padgham, Santa Ana; H. H. Hooper, Whittier; A. Protsch, Redondo.

S. Weinberger, who has been doing business on Main St., will open a jewelry store at 230 S. Spring St., as soon as the store at that location can be made ready for occupancy.

H. J. Whitley is home from Europe. Mrs. Whitley and daughter, who returned with him as far as New York, are spending a short time in the east, but are expected home soon.

Manager Burger, with Thos. B. Clark, began an auction sale, last week. Three auctioneers are employed and three sales are being held daily, forenoon, afternoon and evening. Mr. Burger intends to continue the sale until the entire stock shall be disposed of, if possible.

Chas. Snell, manager of the optical department of the E. W. Reynolds Co., is taking a month's vacation in the Imperial Valley and the neighboring section of Lower California, hunting deer and other game which abound in that vicinity. Miss Lee, formerly in the diamond department of this concern, has returned to her old home in Newark, N. J.

L. C. Pederson has purchased the stock of C. A. Elder, and will again engage in business at Walnut, Ia.

G. B. Stoddard, formerly of Baraboo, Wis., has left for Walla Walla, Wash., where he will engage in the optical business with G. G. Schmeller.

San Francisco.

J. J. Horn, Antioch, Cal., was a trade visitor in this city early in the week.

James E. Tucker, formerly associated with Julius A. Young, is now with W. E. Graves.

F. F. Daunt, Merced, whose wife is ill in a local hospital, has been spending the week in this city.

George E. Bangle, Vallejo, Cal., spent the greater part of the week in this city, combining business and pleasure.

Al. Hansen, probably the largest retailer in Seattle, Wash., is in San Francisco buying stock and attending to other business.

Phil Hess, formerly with Henry M. Abrams, has retired from the trade and is now the manager of a real estate company.

William Glindemann, now at 1532-1534 Fillmore St., will, during the present month, move into a new store in the West Bank building.

M. L. Levy, of M. L. Levy & Co., will build an attractive home on property that he has just bought on the best part of Jackson St. for \$8,000.

Mr. Oberlin, Fresno, Cal., was here buying Summer lines last week. He reports the San Joaquin Valley in good condition, though badly in need of rain.

L. H. Smith, a salesman for A. I. Hall & Son, whose trunks of samples were lost on the wrecked steamer *Pomona*, has recovered his valuable baggage and is again on the road.

The business of George A. Desenfant, of this city, was incorporated last week with a capital stock of \$10,000. The incorporators are F. A. Dunbar, G. A. Desenfant and Jennie Desenfant.

Preliminary advertising is being put out for a big sale of the stock of Kragen's general store. This concern, which has large jewelry and kindred departments, failed about a month ago.

Col. Edwin Manchester, a well-known character of this city and other places east and west, who before the Civil War was with a New York jewelry house, and after the war in the jewelry business for himself, died here a few days ago at the age of 82 years.

Pacific Coast Notes.

Thomas Canty, Watsonville, Cal., was in San Francisco recently on a business trip.

W. C. Guerth, Redlands, Cal., will soon move his store to the First National Bank building.

J. W. Moomaw, Portersville, Cal., has moved into his new building across the street from his old location and adjoining the Pioneer Bank.

Wm. H. Morrison, who has been in the employ of Ed. B. Haas, Haywards, Cal., for some time, has left for Berkeley, Cal., where he was offered a position with the A. A. Handle Co.

W. D. Smith, with L. E. Vaughn, Oxnard, Cal., went to Los Angeles last week for the purpose of buying Spring stock. Mr. Vaughn has recently taken the agency for the Dueber-Hampden watches.

C. M. Deal, formerly of Billings, Mont., has entered the employ of A. H. Davis, Red Lodge, Mont., as watchmaker.

M. L. Jalonack & Co.

The Business Builders

The Business Builders



ANY wholesale jewelry house in Chicago will be glad to recommend us. We have been conducting auction sales for nearly a quarter of a century and we point with pride to the fact that we have never made a failure. Now is the time to write us for an early date. Don't delay. References on request.

The Active, Energetic and Untiring Jewelry Auctioneers



☞ Don't let the opportunity pass of turning your stock into money. This is a good time of the year to do it in. We can make a profit for you. Our methods are up-to-date. Our experience is second to none. No stock is too large for us to handle. Write now.

Correspondence invited from all parts of the United States and Canada. All Communications treated with the strictest confidence.

☞ No question about it, you're sure to make money if we CONDUCT YOUR SALE.

For quick returns, write to our Chicago address

M L. JALONACK & CO.

Chicago, 5339 Prairie Ave.—Long Distance 'Phone, Gray 5234
110 East Washington Street, Syracuse, N. Y.

The Business Builders

Indianapolis.

John Williams spent part of last week with relatives and friends at Carmi, Ill.

After a three weeks' trip, A. W. Gray, of Gray, Gribben & Gray, has returned from Texas.

Harry Reed, who is associated with his father, J. H. Reed, has been seriously ill for three weeks.

Charles Mayer, of Charles Mayer & Co., who accompanied several friends on an automobile trip through Mexico, has returned home.

Out of town jewelers in this city, last week, were: C. K. McCain, Kokomo; C. H. Ankeny, Lafayette; E. M. Wilhite, Danville; F. W. Green, Elwood; J. C. Riedel, Paris, Ill.; E. S. Orr, Greenfield; J. A. Wiessen, Cicero, and Mr. Nehf, of the Swope-Nehf Jewelry Co., Terre Haute.

Local jewelers have received letters from H. Z. & H. Oppenheimer, of New York, advising them to be patient in the present diamond situation. While business may be dull for a time, because of sensational press reports, says the letter, business will soon pick up and there will be no decline in prices.

The regular monthly meeting of the Indianapolis Retail Jewelers' Association was held in the directors room of the Commercial Club, Monday evening of last week. As it was an open meeting there were a number of persons present besides the members. The feature of the meeting was an address of Ralph B. Clark, of Anderson, a retail jeweler and president of the Indiana Retail Merchants' Association. His talk was along the line of parcels post, with which he is thoroughly familiar and concerning the benefit of organization. He advised the association to use its influence against parcels post and to advocate a reduction in letter postage. At the meeting the report of the committee appointed to look into the question of charging a fee for professional services was received and will likely be adopted. The committee recommended that jewelers charge two per cent., with a maximum fee of \$1, for fixing the prices of jewelry or diamonds.

Minneapolis and St. Paul.

The Blumencranz Jewelry Co., Minneapolis, has completed the alterations to the store at 235 Nicollet Ave., and will move therein in a short time.

The coroner's jury that investigated the death of Lawrence Hope, 981 Earl St., St. Paul, who was killed by an Omaha train, in its verdict made some recommendations for improvements at Earl St. crossing for greater protection to the public.

The Minneapolis Publicity Club has instituted a sale of buttons, at 25 cents each, bearing the legend "Minneapolis Makes Good," the slogan for the city, which has been adopted by the club. Retailers in all lines, including jewelers, are handling the buttons. The funds raised will be devoted to advertising the city.

A. T. Niswanger, a traveling salesman for a Chicago jewelry house, was robbed of his grip in the St. Paul Union depot, recently. The contents included sample diamonds and other jewelry and high-

grade tools. The depot authorities telegraphed ahead and had all outbound trains searched immediately, but no trace of the missing grip was found.

Milwaukee.

TRADE CONDITIONS.

It is the general sentiment among Milwaukee jewelers that the expected revival is in full swing. While none is doing exceptional business, there is no complaint. It is a noticeable fact that the number of traveling men visiting the Milwaukee trade is growing week by week, which is taken as an indication that the wholesalers or manufacturers are experiencing a resumption of normal conditions. Easter trade is now on and there is a good demand for diamonds.

Herman Grabemann has sold his business at 8 Nassau St., New York, to Alexander Sireher, and is now with A. Bloedel, 127 Grand Ave., this city.

J. A. Anderson, Mishicot, Wis., will open a jewelry store in the Mill block in Manitowoc, Wis., this month. He is an experienced watchmaker and practical jeweler of 20 years' experience.

H. McEwan, optician, will occupy new quarters in Fond du Lac, Wis., after May 1. The Theater Pharmacy will be closed and will be occupied by Mr. McEwan. It is one of the finest locations in Fond du Lac.

There has been another window theft in Milwaukee. It is the fifth within two months. The window of the Sample Jewelry & Art Goods Co. at 349 3d St., was broken one night recently and jewelry worth \$500 was taken. The thief left a tray of diamonds worth \$600.

E. Q. Nye, referee in bankruptcy, has ordered that a dividend of 15 per cent. be paid to creditors of M. M. Huck, bankrupt jeweler, of Kenosha, Wis. This is the first payment since the failure. It is believed that the proceeds of the sale and the transfer of the business will permit of the declaration of another dividend soon.

Omaha.

O. R. Montague, Lead, S. Dak., has given a chattel mortgage on his stock.

F. E. Sandwall, South Omaha, has been confined to his home on account of illness.

Grover Peterson, with the Sol. Bergman Jewelry Co., is making a business trip through the State.

Mrs. Knapp, wife of H. S. Knapp, with the Shook Mfg. Co., left last week for a visit in Pasadena, Cal.

Noble Wheeler, watchmaker for the Mawhinney & Ryan Co., was called to Vermillion, S. Dak., last week, on account of the illness of his mother.

The following out-of-town jewelers were in this city last week, purchasing stock: A. H. Hastings, Arcadia, Nebr.; Mr. De Nis, Shelton, Nebr.; W. B. Graves, Elkhorn, Nebr.; C. S. Meleck, Orleans, Nebr.; C. S. Huck, North Bend, Nebr.; J. B. Hayden, Turin, Ia., and Mrs. W. A. Quinby, Lead, S. Dak.

The store of G. Ristrom, Braham, Minn., has been destroyed by fire.

The stock of C. P. Smith, Wilton, Wis., was recently sold at auction.

St. Louis.

The L. Bauman Jewelry Co., now located in the Equitable building, has taken a five years' lease of the southeast corner of the Century building on the second floor. The new quarters are considered almost equal to a ground floor store, owing to the exposure down Olive St., making the windows particularly desirable for advertising purposes. The concern has taken about 2,500 feet of floor space. It is said that several other jewelry concerns contemplate taking space on the same floor of the Century building.

The St. Louis Retail Jewelers' Association, a branch of the Missouri Retail Jewelers' Association, at the annual meeting held recently at the Hotel Jefferson, elected the following officers: President, Herman Mauch; vice-president, Otto Buder; treasurer, J. F. Zeitler; secretary, W. F. Kemper; directors, A. Kurtzborn, George Hess, F. W. Drosten, O. H. Kortkamp, Gerhardt Eckhardt, John Schmid, E. S. Zerweck and J. M. Eberling. Resolutions were passed favoring the amending of the national stamping law to compel jewelers to stamp the karat fineness of all gold and the stamping of gold-filled watch cases. The association went on record as favoring the city charter revision and decided to affiliate with the bodies working to that end.

A new type of business building, to be called the Buyers' Club building, is under way in St. Louis. The building, it is claimed, presents many practical features never before carried out on such a large scale. The building will occupy the block bounded by 17th, 18th, Chestnut and Pine Sts., a location within one block of the St. Louis Union Station. Its ground area is 234 by 324 feet, and it will be 18 stories high, with a tower extending 10 stories above the building. It will be given up entirely to the display of merchandise, with the exception of the top floor, which is to be sumptuously furnished for club purposes exclusively for visiting buyers, convention delegates, etc., and the tower, which will contain offices. The eighth floor will be devoted to jewelry, gems, clocks, etc.

Pacific Northwest.

H. M. Huemann, Wardner, Idaho, has added a line of pianos.

Albert E. Tessler, who has been with I. Dornberg, Spokane, Wash., for the past nine years, was married to Mrs. Hattie J. Stimmel, of that city, last week.

The Crown Jewelry Co., Seattle, Wash., through its new president, G. A. Garrett, emphatically denies the truth of the report published early in March that the concern was in the hands of a trustee. Mr. Garrett says there is not a shadow of foundation for such a report, which was probably based on the statement that the stock of the company was owned by three parties. This statement was true in so far as it went, but referred to the capital stock of the company and not to the stock in trade. The Crown Jewelry Co., which formerly had quarters in the G. O. Guy block, is now comfortably located at its new quarters, 247-248 Arcade Annex, where the business is to be continued under the charge of Mr. Garrett as president and H. E. Miller as secretary.

James L. Hand

AMERICA'S LEADING
JEWELRY AUCTIONEER

14 Maiden Lane, New York

Now conducting the auction sale to
liquidate the stock of

W. A. Sturgeon & Co.
DETROIT, MICHIGAN



**This is the largest and finest
jewelry stock ever offered at
auction in the United States.**

- ¶ The auctioneer who can successfully conduct a sale of this magnitude is competent to sell any stock profitably, no matter how large or fine.
 - ¶ Correspondence solicited from the leading jewelers of this country.
 - ¶ Address me at my New York office, or Hotel Tuller, Detroit, Michigan.
-
-

**An Interesting Booklet on Auctions mailed on request
It will tell you of the "Hand" way**

INDEX TO ADVERTISEMENTS.

Bel Bros. & Co.	23	Hedges, A. J., & Co.	19	Prior, Charles M.	56
Best Comb & Novelty Co.	24	Hedges, Wm. S., & Co.	48	Providence Stock Co.	30
Best Mfg. Co.	Inside front cover	Heller, L., & Son.	42	Prybill, P.	105
Berlian Gem & Pearl Co.	50	Herpers Bros.	98	Racine, Jules, & Co.	78
Berlean-Swiss Watch Co.	92	Himalaya Mining Co.	54	Randall, C. Ray	14
Berleann Platinum Works.	106	Hodenpyl & Walker	44	Ranlett & Lowell Co.	105
Berlean Watch Case Co.	93	Hoffman Novelty Co.	54	Reichhelm, E. P., & Co.	98
Best Crown Mfg. Co.	26	Hold-On Clutch Co.	27, 28	Reichman, A.	42
Arizona Turquoise Mines Co.	42	Hotel St. James	102	Renziehausen, W. F., & Co.	104
Best Bros. & Co.	38	Hraba, Louis W.	100	Revell, A. H., & Co.	98
Best Bros. Co.	68	Hyde & Co.	93	Richards, J. M.	48
Best, John, & Son.	105	Illinois Watch Co.	66	Richards, W. E., Co.	25
Best & Co.	46	Ingraham, E., Clock Co.	92	Richardson, Enos, & Co.	18
Best, Geo. M.	104	Irons, Joseph	100	Robblus, Chas. M., Co.	29
Best, Webb C., Watch Co.	93	Irvling Cut Glass Co.	100	Robert, E. E.	90
Bestkopf, Henry	24	Jacot Music Box Co.	100	Roger Williams Silver Co.	57
Best Jewelry Co.	30	Jalounek, M. L., & Co.	72	Rohrbeck, John E.	25
Best & Bacon	14	Janitschek Co.	98	Roseman, A.	50
Best, J. & H.	98	Jeanne, F. A.	48	Roy Watch Case Co.	93
Best, Chester, & Son.	44	Juergensen, Jules	92	Rudolph & Snedeker	92
Best, R. W.	102	Juzek, T. J., & Co.	48	Rumpp, C. F., & Sons.	102
Best, R., & Co.	8	Kahn, L. & M., & Co.	38	Saunders, Meurer & Co.	48
Best & Vitelli	52	Keller Jewelry Mfg. Co.	20	Schultz & Co., Inc.	22
Best, J. B., & Co.	20	Kelly & Stefnman	100	Sessions Clock Co.	92
Best Polytechnic Institute.	93	Kent & Woodland	20	Smith, Alfred H., & Co.	42
Best, D. F., Co.	13	Ketcham & McDougall	54	Smith, Frank W., Co.	15
Best, M. B., & Co.	21	Keystone Watch Case Co.	86	Snow & Westcott Co.	25
Best, Townsend & Swenarton	78	Kirby, H. A.	60	Sohn & Hyman	54
Best, Howe & Co.	19	Kohlbusch, Herman, Sr.	98	Solidarity Watch Case Co.	16
Best National Bank	62	Kohn, Alois, & Co.	20	Spencer, E. L., Co.	29
Best Art Metal Works.	70	Kollmar, Rauch & Co.	19	Star Watch Case Co.	6
Best Frères	24	Krementz & Co.	17	State Bank	62
Best, S., Co.	22	Kruter & Sons	36	Steiner, Louis	106
Best & Court	56	Lederer, S. & B., Co.	28	Stern Bros. & Co.	48, inside back cover
Best, M.	27	Lees & Sanders	104	Sternau, S., & Co.	12
Best & Bequelln	44, 60	Lelong, L., & Bro.	105	St. Louis Watchmaking School.	105
Bestman Co.	50	Lewy & Cohen	21	Street, Geo. O., & Sons.	20
Best & Fitzgerald	102	Lisner, D., & Co.	15	Superior Comb Co.	48
Best, Clark & Co.	22	Lorsch, Albert, & Co.	38	Sussfeld, Lorsch & Co.	95, 106
Best, Louis J.	25	Loth, Joseph, & Co.	70	Swartehild & Co.	70
Best, Wm., Inc.	104	Lowe, Edwin, & Co., Inc.	30	Theberath & Co.	21
Best, Bagnall & Co.	30	Maiden Lane Realty Co.	64	Thomas, Seth, Clock Co.	89
Best, C., & Sons.	100	Maintien Bros. & Elliot	25	Title Guarantee & Trust Co.	62
Best, O. M., Estate.	32	Market & Fulton National Bank	62	Trout, Charles L., & Co.	25
Best Watch Case Co.	88	Mathey Bros., Mathez Co.	94	Unique Art Glass & Metal Co.	102
Best-Hampden Watch Mfg. Co.	10	Mercantile National Bank.	63	Untermeyer-Robbins Co.	56
Best, T. J., Co.	25	Miller, Fuller & Whiting Co.	31	Urich, S.	102
Best & Co.	18	Morstrom, W. G.	50	U. S. Smelting & Refining Works.	105
Bestberg & Co.	54	Mount & Woodhull	46	Vacheron & Constantin	90
Bestmann Bros.	44	Murray, Dan I.	70	Van Dam, Eduard	40
Best National Watch Co.	84	Myers, J. A.	78	Van Dusen & Stokes Co.	13
Best, P. H. Chain Catch.	26	Myers, S. F., Co.	26	Wachenheimer Bros.	30
Best, Joseph, & Co.	3	Nassau Bank	46	Wachter Mfg. Co.	94
Best, Louis	52	New England Watch Co.	91	Waite-Thresher Co.	32
Best, Theodore W., & Bro. Co.	34	New York Tortoise Shell Co.	98	Waldron & Carroll	29
Best, B. S., Co.	24	Nissen, Ludwig, & Co.	46	Waltham Watch Co.	82
Best, Henry, & Bro.	16	Noel, Rudolph, & Co.	40	Washburn, C. Irving	100
Best & Griser	26	Omega Watches	90	Wells, Chester H.	27
Best Building	78	Oneida Community, Ltd.	Outside back cover	Wendell & Co.	7
Best Sales Co.	33	Oppenheimer Bros. & Veith	40	Wheeler, Hayden W., & Co.	40
Best, C. P., & Co.	27	Oskamp-Nolting & Co.	25	Whiting & Davis	12
Best, Leo.	48	Osmers-Dougherty Co.	22	Whiting, F. M., & Co.	57
Bestfriend Bros.	52	Osmun-Parker Mfg. Co.	18	Whiting Mfg. Co.	9
Best Co.	58	Ostby & Barton Co.	31	Wightman & Hough Co.	26
Best, Electric Co.	46	Pairpoint Corporation	100	Wittstein, Chas. T.	26
Best, Wm. C., Co.	27	Papazian, A. D.	93	Wolfshelm & Sachs	24
Best, August	104	Patek, Philippe & Co.	91	Wollstein, L. & M.	105
Best, M.	31	Penfold, Wm. C., Co.	94	Wood, Chas. F., & Co.	44
Best, T. B., Ltd.	104	Pitcairn, W. S.	102	Wood, J. R., & Sons.	4, 5
Best, Riglander & Co.	11	Pitzele, S.	70	Zarembowitz, A.	105
Best, James L.	74	Potter, E. A., Co.	65e	Zimmer, Henry, & Co.	106
Best & Harrington	92	Potter & Buffinton Co.	28		

Special Notices.

Payable invariably in advance.

Rates 75c. per insertion for notices not exceeding 25 words; additional words, 2c. each.

SITUATIONS WANTED, 1c. a word each insertion; minimum charge, 25c.

Heavy type, 5c. a word; minimum charge, \$1.25. Display cards, \$2.00 per inch.

In all cases, if answers are to be forwarded, 10c. extra to cover postage must be enclosed.

All answers to advertisements addressed care The Jewelers' Circular-Weekly, should be sent to the New York Office, unless the Chicago Office is specifically mentioned.

Situations Wanted.

WANTED, position in jewelry store by first class engraver. Address "A. F., 3819," care Jewelers' Circular-Weekly.

WATCHMAKER wants position; experienced on Swiss and American watches; complete set of tools. Ed. Herzberg, 402 E. 79th St., New York.

POSITION desired by a gilder, capable of making all colors, understands polishing and lapping. Address "N., 3824," care Jewelers' Circular-Weekly.

CLOCKMAKER, age 21, good, all around man, desires position; have full set of tools and best reference. Address "J., 3896," care Jewelers' Circular-Weekly.

POSITION WANTED by a good, all around workman, nice engraver and good salesman; reasonable wages. Address P. O. Box 107, Linden Heights, O.

FIRST CLASS engraver and salesman, with some knowledge of watch work and fine tools desires position. Address "B. M. H., 3950," care Jewelers' Circular-Weekly.

JEWELER and engraver, also watchmaker, wishes to change; south preferred; competent young man; references. Address "V., 3779," care Jewelers' Circular-Weekly.

YOUNG MAN, 20 years of age, desires position as clerk in jewelry firm; have some experience; can furnish best of references. "D., 3894," care Jewelers' Circular-Weekly.

WATCHMAKER, can do clock and jewelry repairing, wishes position; best references; 13 years' experience. "Watchmaker," 120 Middleton St., Brooklyn, N. Y.

SALESMAN, with established trade throughout middle and northwestern States; jewelry, sterling or souvenir line. Address "M., 3929," care Jewelers' Circular-Weekly.

FIRST CLASS diamond setter desires position with good firm; A1 references; no objection to going out of town. Address "P., 3870," care Jewelers' Circular-Weekly.

MANUFACTURING JEWELER and stone setter wishes position; best of reference; can wait on trade; store position preferred. "R., 3926," care Jewelers' Circular-Weekly.

SALESMAN, young man, 22, covering the middle western States, with gold filled line of jewelry, desires to make a change. Address "C., 3916," care Jewelers' Circular-Weekly.

POSITION WANTED by young man to finish trade; can do engraving and watchmaking; have full set of tools and good references. "M., 3836," care Jewelers' Circular-Weekly.

DESIGNER on class pins, medals, badges and fraternity pins, desires position with reliable house; can make attractive sketches. "C., 3676," care Jewelers' Circular-Weekly.

WANTED, a position by first class watchmaker and engraver; in or near New York preferred; 10 years' experience; best references. "X. L. C., 3892," care Jewelers' Circular-Weekly.

I WISH to make a change, so I am open for a position April or May; fine watchmaker and engraver with 25 years' experience; east or south preferred; will send samples of work and best of references. Address "Engraver, 3833," care Jewelers' Circular-Weekly.

FIRST CLASS watchmaker, with tools, desires position at once; moderate salary; references; competent to handle railroad work. Address "E. H. B.," 45 Charles St., Springfield, Mass.

YOUNG MAN, 21, having five years' experience with diamond importing house, desires to make a change; can furnish best of reference. "V., 3939," care Jewelers' Circular-Weekly.

EXPERIENCED watchmaker and engraver would like permanent position in first class store, desires a change; east preferred. Address "A. R., 3645," care Jewelers' Circular-Weekly.

A FIRST CLASS watchmaker, experienced in adjusting, manufacturing and repairing high grade watches, wants position. Address "L. F. P., 3763," care Jewelers' Circular-Weekly.

YOUNG MAN, 25 years old, well acquainted with white stone jewelry, speaking German, French and English, wants position; best references. "Y., 3925," care Jewelers' Circular-Weekly.

BY YOUNG MAN, with four years' experience as salesman, clock and jewelry repairer; speaks German; references furnished; salary, \$12 a week to start. Address F. E. Rohloff, R. R. 5, Appleton, Wis.

WANTED, position by young lady with three years' office experience, writing good hand and able to furnish good references; moderate salary. Address "I., 3828," care Jewelers' Circular-Weekly.

POSITION WANTED by young man as watchmaker; nine years at the business, two years on railroad work; can do jewelry and clock work; A1 reference. Address Oscar Corman, Bloomington, Ill.

FIRST CLASS watchmaker, 35, also optician and salesman, 22 years' experience, desires position; wages, \$25 per week; willing to go anywhere. Address "Competent, 3930," care Jewelers' Circular-Weekly.

YOUNG MAN, 26, having 12 years' experience with jewelry jobbing and new work in platinum and gold, desires position; able to take care of a shop. Address "N., 3944," care Jewelers' Circular-Weekly.

POSITION WANTED by watchmaker of 20 years' experience on high grade American and Swiss watches; accustomed to serve on trade; not an engraver. "R. M., 3951," care Jewelers' Circular-Weekly.

ENGRAVER, young man, desires position with first class engraver, or an opportunity to learn watch work; good script letterer; samples on request; A1 reference. "D., 3602," care Jewelers' Circular-Weekly.

MANUFACTURER'S LINE wanted on commission for jobbers or department store trade for New York City; established trade, can show good improvements. Address Erle R. Sheppard, 63 Maiden Lane, New York.

BOOKKEEPER, charge of stock, filling orders, selling; young woman, eight years in wholesale jewelry business, having entire charge; excellent reference; would leave town. Address "G., 3907," care Jewelers' Circular-Weekly.

YOUNG MAN, good jeweler, with some experience in watch and clockmaking and waiting on trade, willing to work at moderate salary in or out of New York City; state details. Address "W., 3941," care Jewelers' Circular-Weekly.

FIRST CLASS watch and clockmaker, 25 years old, 17 years' experience on German, Swiss and complicated watches, desires permanent position; speaks French, German and understands English. Address Foerster, 37 Bank St., New York.

A FIRST CLASS watchmaker, 25 years' experience on high grade American and Swiss watches, wishes a steady position; can start at once in vicinity of New York City. Address "K., 3541," care Jewelers' Circular-Weekly.

WATCHMAKER, first class workman, who is honest, sober and reliable, wishes a steady position; willing to go anywhere; has full set of tools; can furnish best of reference. Address "E. V., 3947," care Jewelers' Circular-Weekly.

SMALL MANUFACTURER in silver and jewelry, in need of a first class engraver for sample work, model chaser, saw-pieces and designer; willing to work hard and grow with your business. Address A. A. Brindley, Bridgeport, Conn.

WANTED, position by refracting and manufacturing optician of many years' experience, also first class engraver and jewelry salesman; can do rimless edging, mounting, frame fitting, etc.; gilt edge references from highest class establishments in United States; correspondence solicited from responsible firms. "S., 3899," care Jewelers' Circular-Weekly.

SILVERWARE SALESMAN, recently with large New York, Fifth Ave. house, desires position; retail or wholesale; competent salesman; can furnish best references; no objection to leaving New York. Address "F., 3942," care Jewelers' Circular-Weekly.

YOUNG MAN, 19, with experience in jewelry repairing, wishes position in a store; would like to learn watchmaking and engraving; willing to leave city; kindly state salary you offer; active and trustworthy; good references. Address "S. T., 3901," care Jewelers' Circular-Weekly.

TRAVELING MAN, 23, thoroughly acquainted from New York to the coast with department store, wholesale, retail and manufacturing trade, also precious stone trade, desires to connect with first class house; highest references. "Hustler, 3934," care Jewelers' Circular-Weekly.

A1 WATCHMAKER, fine engraver and graduate optician, 23 years' experience; several years in present position as first man in large store; do not repair clocks or jewelry; would not go east of Indiana; \$18 to \$20; first class references. Address "S. J., 3862," care Jewelers' Circular-Weekly.

YOUNG MAN, with 10 years' experience in the jewelry business and six months' road experience covering Illinois and Iowa, would like to represent New York or Chicago house with staple line of medium priced jewelry on commission basis; would prefer same territory; can furnish bond. "H., 3905," care Jewelers' Circular-Weekly.

OPTICIAN, first class refractionist, edge grinder and salesman, competent to take charge of department, who is also all around man in jewelry store, would like good position after April 15 or would like good business proposition; medium size, busy New England city preferred; references. Address "Q., 3840," care Jewelers' Circular-Weekly.

WATCHMAKER, having 29 years' experience, as foreman in best Swiss and French factories; expert, particularly in precision of watches; now employed by Henry Birks & Sons jewelers, Montreal. Apply to F. d. Paris, 157 Amherst St., Montreal, Que.

Side Lines Wanted.

WANTED, by young man, manufacturer's line of solid gold or plated jewelry on commission, in Chicago and suburbs. Address "I., 3913," care Jewelers' Circular-Weekly.

TWO EXPERIENCED salesmen, with headquarters in San Francisco, want strong lines for the retail jewelers or department stores on the Pacific coast; references. Address 1537 Fulton St., San Francisco, Cal.

WESTERN representative would like establish side line to carry in connection with plated jewelry; now selling jobbers in large department stores in middle west. Address "Salesman 3922," care Jewelers' Circular-Weekly.

WANTED, a jewelry or kindred line for the jobbing trade; middle western territory; have own office in Chicago. Address I. S. Richter, care of Narragansett Hotel, Providence, R. I.

Help Wanted.

WANTED, a good watchmaker for a suburb town; permanent position. Apply H. J. Myer, 20 Maiden Lane, New York.

WANTED, watch case repairer; state age, experience and by whom you were last employed. Address Drawer No. 1127, Kansas City, Mo.

WANTED, an experienced inside salesman by prominent Maiden Lane wholesale house, salary and particulars. Address "D., 3938," care Jewelers' Circular-Weekly.

WANTED, a good all around watchmaker, jeweler and engraver for southwestern town with 15,000 population. Address L. Bauman Jewelry Co. Equitable Bldg., St. Louis, Mo.

YOUNG MAN, experienced in watch material at jewelers' supplies, to take full charge of business in west; opportunity for acquiring an interest for right man. Address "H., 3928," care Jewelers' Circular-Weekly, 501 Heyworth Bldg. Chicago, Ill.

HELP WANTED.—Continued.

ENGRAVER and die sinker wanted; must be capable of doing first class work in gold and steel, also familiar with modeling in wax. Address "E., 3849," care Jewelers' Circular-Weekly.

WANTED, first class jeweler to take charge of shop with retail store in Illinois; give references; permanent. Address "K., 3781," care Jewelers' Circular-Weekly, 501 Heyworth Bldg., Chicago, Ill.

WANTED, at once, a first class watchmaker and engraver; good wages and permanent position to the right man; state wages and send reference in first letter. Tillson Jewelry Co., Carrington, N. Dak.

SALESMAN for rapid selling specialty as side line, made up in sterling silver and plate; large commissions can be made; pocket sample furnished. Address "G., 3898," care Jewelers' Circular-Weekly.

WANTED, jeweler and engraver with store experience and competent to wait on fine trade; steady position to an American of good appearance. Address "T., 3903," care Jewelers' Circular-Weekly.

WANTED, watchmaker, one who can do plain engraving, stone setting and hard soldering; none but a first class man wanted; state salary wanted; must come well recommended. D. H. Keene, Fort Worth, Tex.

ADVERTISER desires services of one who can undertake the compiling of a small tool and material catalogue; moderate salary; experience necessary; state salary expected, experience, etc. "Hustler, 3927," care Jewelers' Circular-Weekly.

WANTED, July 1, salesman for high grade line of gold jewelry and novelties; Pennsylvania territory; only experienced men with trade need apply; state salary wanted and full particulars; confidential. "Good Chance, 3837," care Jewelers' Circular-Weekly.

WANTED, by first class house in large Texas city, first class jeweler and engraver on new work and repairs; permanent position, good salary; send samples of engraving and copy of references in first letter. Address "L., 3694," care Jewelers' Circular-Weekly.

WANTED, competent engraver and watchmaker with ability as salesman; must be American with unquestionable references; small salary to begin; position is a responsible one but will increase right man; give age, experience and salary required. Address "A. B. C., 3945," care Jewelers' Circular-Weekly.

WANTED, first class watchmaker, jewelry repairer and engraver, also good on clocks; permanent position to efficient man; wages no object; must own tools, except bench and foot wheel; one of the nicest cities in Montana; state salary and all information in first letter with references. "M., 3881," care Jewelers' Circular-Weekly.

Business Opportunities.

FOR SALE, old established jewelry store on Eighth Ave., New York; excellent opportunity. Address "P., 3948," care Jewelers' Circular-Weekly.

J. M. ROSSI, 20 Maiden Lane, New York, desiring to retire from active business, will sell his entire stock of high grade jewelry amounting to about \$2,000.

WANTED TO BUY a jewelry store for spot cash, or any part of your stock; deal with a man with a rating and reputation. Dan I. Murray, 3 Maiden Lane, New York.

\$1,000 WILL BUY an old established jewelry store in South Brooklyn, N. Y.; a splendid opportunity for a good man; reason for selling, other business. Address "V., 3835," care Jewelers' Circular-Weekly.

FOR SALE, a good paying double jewelry store in New York; rent, \$55, with living apartments; price, \$1,000; with stock, \$5,000; reason for selling, bad health. Address "H. W., 3911," care Jewelers' Circular-Weekly.

HIGHEST cash prices paid for watches, diamonds and jewelry; quick and liberal returns; all business confidential; bank references; Telephone Blue, 995. E. Noel, 552 E. 46th Place, Chicago, Ill.

FOR SALE, on account of sickness, an enameling shop for jewelry, established for 25 years; would also accept a competent man for partner instead; location, Newark, N. J. Address "E., 3757," care Jewelers' Circular-Weekly.

FOR SALE, jewelry and musical store in best town of South Carolina; population 2,000, with county seat, 30,000; invoice can be reduced to \$1,500; repairs cover all expenses; best chance for right man. "S., 3908," care Jewelers' Circular-Weekly.

ADVERTISER would invest \$15,000 to \$20,000 in established, paying, retail jewelry business, in city of 100,000 or over; prefers to purchase outright, but might consider part interest with management, for which advertiser is well fitted. "E., 3937," care Jewelers' Circular-Weekly.

FOR SALE, best jewelry store in good manufacturing town of 5,000 inhabitants; best location; stock and fixtures invoice about \$3,000; good chance for a live man; asthma and poor health only reason for selling; must change climate. Address Chas. P. Eisenmann, Three Rivers, Mich.

JEWELRY BUSINESS in growing manufacturing town in Massachusetts of over 7,000 inhabitants; ill and old age; want to retire; stock and fixtures about \$2,500; can reduce to any reasonable amount; grand opening for watchmaker and optician. Address "Opportunity, 3906," care Jewelers' Circular-Weekly.

ENTIRE jewelry store for sale; going out of business, ill health, would like somebody to buy me out and continue in this place; I made lots of money here; stock of jewelry, musical instruments, phonographs included, guns and ammunition; will sell out to suit buyer and assist him for a long time. Ed. Rieth, 1650 Michigan Ave., Detroit, Mich.

WELL BOUGHT is not only half sold, but beats the other fellow as he sleeps; you can make money if you will get a selection package of my jobs bought at government and trade auction sales; they consist of real corals, ambers, jets, gun metals and novelties of all kinds, also watches and diamonds; all sold under the regular price; sent on memo, bills to jewelers with a rating; select what you want, return the rest; place cash in box for what you keep. Dan I. Murray, 3 Maiden Lane, New York.

DO YOU NEED MONEY? If so, send your diamonds and watches to me and get quick and liberal returns; highest cash prices paid for entire jewelry stocks; will send our representative if necessary; business confidential; National Bank references. H. Schwartz, 807 Chicago Savings Bank Building, Chicago, Ill.

DO YOU WISH TO RETIRE? Why not turn your entire store or surplus stock into cash? We pay the highest prices, also advance liberal cash amounts on stocks; communicate with us before consulting others; we act quick and strictly confidential. Brooklyn Purchasing Syndicate, 608 Broadway, Brooklyn, N. Y., Telephone, 2328 Williamsburg.

To Let.

TO LET, light office, ninth floor. Apply between 2 and 4, J. F. Braun, 37 Maiden Lane, New York.

TO LET, desk room from May 1. T. G. Frothingham & Co., Room 1501, 9 Maiden Lane, New York.

TO LET, a desirable office, 170 Broadway, with or without partitions; liberal reduction in rent. Particulars, Room 1003, 527 Fifth Ave., New York.

PART OF STORE to let with optician, suitable for watchmaker and jeweler; lively neighborhood. Address Fredsell & Co., 161 E. 34th St., New York.

TO LET, third floor of building in Newark, N. J., opposite Market St. station, with steam heat, power and elevator service; size of floor, 115 ft. by 39 ft.; well lighted and specially adapted for manufacturing jewelers. Address Cyrus Currier & Sons, 365 Market St., Newark, N. J.

TO SUB-LEASE, part of factory with excellent light and fully equipped with power, etc.; very reasonable rent and desirable location; uptown New York City. Apply "C., 3923," care Jewelers' Circular-Weekly.

FOR RENT, repair shop in New York City for jobbing jeweler; dynamo and complete fixtures already installed; excellent location and good opportunity for practical man. "Repair, 3956," care Jewelers' Circular-Weekly.

For Sale.

FOR SALE, three-horse power motor, partitions and iron railing. Address Benj. S. Sugarman, 12 John St., New York.

FIXTURES for sale, eight plate glass 10-foot wall cases, eight plate glass 12-foot counter cases, eight counters, plate glass crystal room regulator, sidewalk clock, rolls, buffs, etc., burglar and fireproof safe, all in perfect condition; will sell all or any part. Trask & Plain, Quincy, Ill.

FOR SALE, safes, counters, jewelers' scales, diamond scales, partitions, desks, etc. A. Lounsbury & Son, 9 and 11 Maiden Lane, New York.

FOR SALE, machinery, hydraulic press, lathes, drills, lapps, tools, cutters, foot presses and dies, comprising a lot of absolutely new ones. A. Lounsbury & Son, 9 and 11 Maiden Lane, New York.

Wanted to Purchase.

WANTED TO PURCHASE, a large watch sign, 60 to 72 inches in diameter; state condition, price, etc. J. F. Carr, Portsmouth, O.

WANTED, a wall show case with shelves, in good order, not over seven feet long, to display silverware; state description and lowest cash price. Address "Showcase, 3904," care Jewelers' Circular-Weekly.

Miscellaneous.

I WOULD LIKE to know the present whereabouts of one Thomas Gwaltney, a watchmaker. Address P. W. Caine, 567 Pearl St., Beaumont, Tex.

WOULD LIKE to know the present address of E. Doty, jeweler, formerly located at Harrington, Wash. M. F. Patterson & Co., Box 1845, Spokane, Wash.

FOREMAN WANTED

for factory, manufacturing sterling silverware. A party is wanted experienced in all details of getting out hollow ware, flat ware, silver jewelry and novelties. A good mechanic with executive ability will be liberally dealt with. Address in confidence, stating full particulars, if employed at present, salary desired and age.

Address "STERLING," 794 Broad St., Newark, N. J.

Gems and Precious Stones

Cloth, Postpaid, \$1.00

Published by

The Jewelers' Circular Pub. Co.
11 John Street NEW YORK

GUINAND'S
RELIABLE SPLIT TIMERS
AND....
SPLIT CHRONOGRAPH WATCHES

In NICKEL, GUN METAL, SILVER
 AND GOLD FILLED CASES

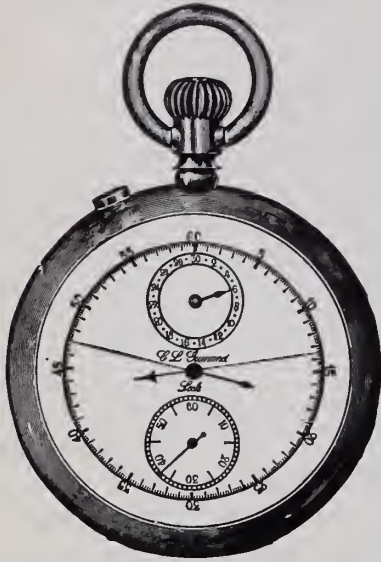

JULES RACINE & CO.

EXCLUSIVE IMPORTERS

Chicago Office: New York Office:
 103 State Street 37 Maiden Lane
 FOR SALE BY ALL JOBBERS



Light Lofts To Let

IN THE NEW

GIBSON BUILDING

N. W. Cor. John and Gold Streets
 NEW YORK

About 4,200 square feet for Light Manu-
 facturing or Show Rooms.

ELECTRIC ELEVATOR AND STEAM HEAT

All lofts wired for power. Apply to your
 Broker or on Premises.

S. F. MYERS BLDG.

47-49 Maiden Lane, N. Y.

For Rent

A few choice, light and
 very desirable offices

Moderate Rentals

Details of

J. A. MYERS

On Premises

Byrnes, Townsend & Swenarton
Patent Lawyers

(Examiners U. S. Patent Office)
 277 Broadway New York
 Patents Trade-Marks

Practical Course
in Adjusting

By **THEO. GRIBI.**

COMPRISING

A review of the laws governing the motion of the
 balance and balance spring in watches and
 chronometers, and application of the principles
 deduced therefrom in the correction of vari-
 ations of rate arising from want of isochronism,
 change of position and variation of temper-
 ature.

ELUCIDATED AND DEMONSTRATED

by original experimental researches in the actual
 problem, never before published, showing the
 causes that are operative in the variation of
 rate, and leading to correct remedies. To
 which have been added chapters on

Published Price, \$2.50.

SPECIAL REDUCED PRICE, \$1.50,

Post prepaid.

250 pages, including 18 diagram plates; Fine
 Paper; Large Type; Clear Illustrations; System-
 atically arranged; Solid Binding.

THE JEWELERS' CIRCULAR PUB. CO.

Publishers

11 John St., cor. Broadway, New York.

Gems and
Precious Stones

THEIR

Characteristics, Locali-
 ties of Production,
 Tests and Some Cur-
 rent Literature.

A new book on a new plan.
 Tabulated, concise, authoritative.

A handy manual for every
 Jeweler.

CONTENTS

CHARACTERISTICS and LO-
 CALITIES of PRECIOUS
 STONES

Shows in tabulated form the
 Chemical Composition, Crys-
 tallography, Common Frac-
 ture, Lustre, Hardness, Color,
 etc.

TESTS FOR PRECIOUS
 STONES:

Describes testing implements,
 methods of testing, mineralog-
 ical characteristics, specific
 gravity, dichroism, tests, etc.

FAMOUS DIAMONDS OF THE
 WORLD.

SOME FAMOUS DIAMONDS.
 BIRTH STONES OF VARIOUS
 NATIONS.

GEMS FOR THE DAYS OF
 THE WEEK.

POETRY OF GEMS.

BIRTH STONES AND THEIR
 SIGNIFICANCE.

SIGNIFICANCE OF SOME
 GEMS.

BIRTHDAY FLOWERS.

ZODIACAL SIGNS OF FLOW-
 ERS.

WEDDING ANNIVERSARIES.

FLOWERS OF THE MONTH.

OFFICIAL FLOWERS OF THE
 UNITED STATES.

CLOTH, POSTPAID, \$1.00

PUBLISHED BY

The Jewelers' Circular
Publishing Co.

11 John Street New York

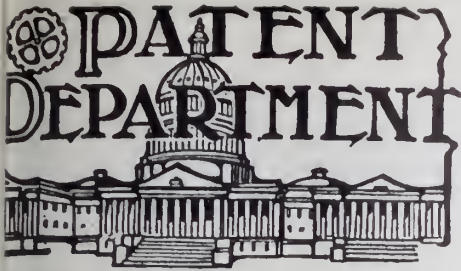

IN WHICH IS CONTAINED A LIST OF THE LATEST PATENTS GRANTED BY THE UNITED STATES AND GREAT BRITAIN, THE UNITED STATES PATENTS THAT HAVE EXPIRED AND THE REGISTERED TRADE-MARKS.

UNITED STATES PATENTS.

ISSUED MARCH 31, 1908.

883,273. TIME-SWITCH. CHARLES E. AVERY, Jersey City, N. J.. Filed Aug. 1, 1906. Serial No. 328,688.

In a time-switch, the combination of a timekeeping device, a rotating arbor controlled thereby, a

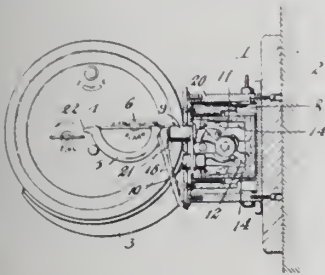

cam carried thereby, a push button switch, a lever actuated by said cam to operate a push button of the switch and a spring secured to said lever to furnish a yielding connection between the cam and the lever.

883,355. TIME-RECORDER. JOHN D. SMITH, St. Louis, Mo. Filed June 11, 1906. Serial No. 321,235. Renewed Aug. 21, 1907. Serial No. 389,543.

A time-recorder embodying a horizontally shiftable carrier having a chart provided with record spaces, a vertically-movable guide frame arranged forwardly of said carrier and provided with guide sockets positioned in suitable relation with respect

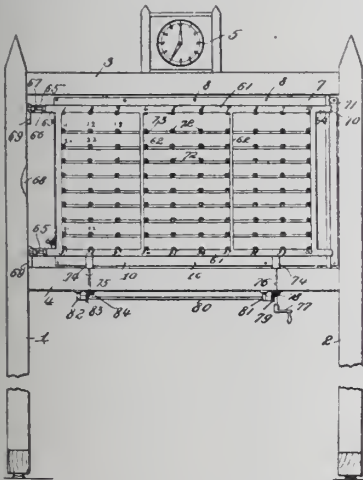

to the spaces of the record chart, and stamping members adapted to be passed through the sockets and to engage the chart to make a record in the spaces.

883,473. TIME-RECORDER. ABRAHAM A. NEWMAN, Chicago. Filed Jan. 12, 1906. Serial No. 295,700.

The combination with a reciprocating device having long movements which it is desired to record of a second device capable of shorter reciprocations, a clock operated record-carrying device, two recording devices arranged to produce different records

on a sheet carried by said record-carrying device, means whereby the second reciprocating device produces alternate operations of the recording devices as it is reciprocated, and means of connection

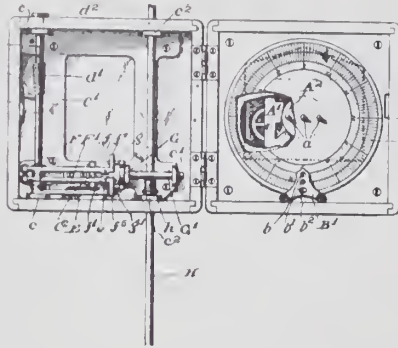

between said two reciprocating devices whereby they complete their reciprocations at approximately the same time.

883,665. COMBINED POLICE-CALL, FIRE-ALARM AND WATCHMAN'S BOX. JAMES G. NOLEN (Chicago, assignor of one-half to Frank B. Cook, Chicago. Filed March 3, 1904. Serial No. 196,435.

A box for transmitting signals comprising normally wound-up clock work, and means for re-

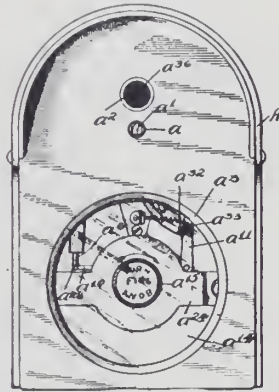

leasing said clock work comprising a rotary and axially movable part, operatively associated with the clock work to release said clock work by either rotary or axial movement.

DESIGNS.

30,227. BADGE. CHARLES A. WINSHIP, Chicago.



Filed Jan. 16, 1908. Serial No. 411,184. Term of patent 7 years.

30,228. TRAY OR RECEPTACLE. FRANK ERN-



EST BARKER, Birmingham, England, assignor to Barker Bros., Silversmiths, Ltd., Birmingham, England. Filed Dec. 23, 1907. Serial No. 407,851. Term of patent 7 years.

ham, England. Filed Dec. 23, 1907. Serial No. 407,851. Term of patent 7 years.

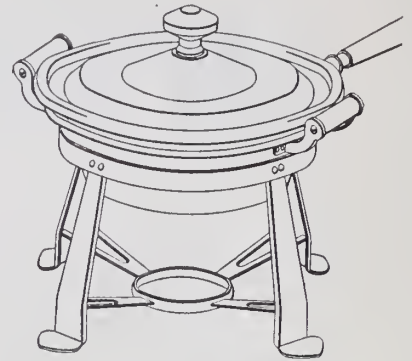

30,229. CHAFING-DISH AND STAND. CHAS. NELSON, Brooklyn, N. Y., assignor to S. Ster-

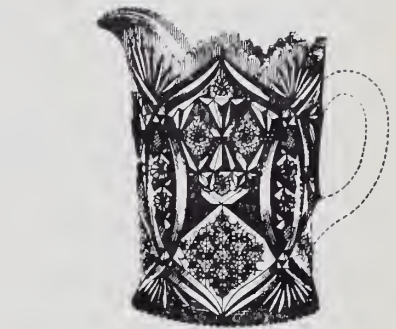

nau & Co., New York. Filed Feb. 8, 1908. Serial No. 414,987. Term of patent 7 years.

30,230. GLASS VESSEL. ORLANDO J. W. HIGBEE, Crafton, Pa., assignor to the John B.

UNITED STATES TRADE-MARKS.

[The following trade-marks have been adjudged entitled to registration under the Act of Feb. 20, 1905, and are published in compliance with Section 6 of said act. Said section provides:

"Any person who believes he would be damaged by the registration of a mark may oppose the same by filing notice of opposition, stating the grounds therefor, in the Patent Office, within 30 days after the publication of the mark sought to be registered, which said notice of opposition shall be verified by the person filing the same before one of the officers mentioned in Section 2 of this act. If no notice of opposition is filed within said time the commissioner shall issue a certificate of registration therefor, as hereinafter provided for."

Marks which are stated to have been "Used 10 years" are registrable under the last proviso of Section 5 of said act, which is as follows:

"And provided further, that nothing therein shall prevent the registration of any mark used by the applicant or his predecessor, or by those from whom title to the mark is derived, in commerce with foreign nations or among the several States, or with Indian tribes, which was in actual and exclusive use as a trade-mark of the applicant or his predecessor from whom he derived title for 10 years next preceding the passage of this act."]

PUBLISHED MARCH 31, 1908.

Ser. No. 31,439. (CLASS 28. JEWELRY AND PRECIOUS-METAL WARE.) AUSTIN & STONE, Attleboro, Mass. Filed Nov. 29, 1907.



Particular description of goods.—Plated chains and bracelets.

Ser. No. 32,748. (CLASS 27. HOROLOGICAL

THE OPTICAL REVIEW

FOR APRIL

- ☐ A High Class Magazine for Opticians and Optometrists.
- ☐ A Worthy Representative of an Important Industry.
- ☐ Publishes the Best Optical Literature Procurable and All the News.

THE OPTICAL REVIEW is the greatest aid to the advancement and progress of the optical department, the optician and optometrist.

No jeweler with an optical department can afford to be without it.

CONTENTS FOR APRIL

- "Nervous System and the Sense of Sight." By F. Lee Fuller, Los Angeles, Cal.
- "Suggestions to Optometrists." By I. M. Radabaugh, Hastings, Minn.
- "Theoretical Skiametry." By Ralph H. Woods, South Bend, Ind.
- "Simple Methods in Subjective Optometry." By W. P. Hedrick, Raleigh, N. C.
- "Phacology: Its Application in Optometry—III." By R. H. Knowles, M. D., New York.

- "Prisms in Ocular Practice—X." By John C. Eberhardt, Dayton, O.
- "Ophthalmic Measurements." By E. Le Roy Ryer, New York.
- Digest of Current Optometrical Literature—Examination Room Work—Optometrist's Catechism—Questions and Answers—Making the Sale—New Articles for Store and Office—Editorials—News of the Month—Developments in the Movement for Optometry Laws—Conventions of State Societies—Other Meetings—Patents.

☐ We exclusively extend to subscribers of THE JEWELERS' CIRCULAR-WEEKLY the privilege of subscribing to THE OPTICAL REVIEW at one-half price—50 cents per year. If you have not already mailed your subscription, simply sign and return the attached form, sending no money in advance.

☐ Carefully read the blank below. Send at once and get the April issue.

ISSUED MONTHLY.

SUBSCRIPTION, \$1.00 PER YEAR.



Published by
THE JEWELERS' CIRCULAR PUBLISHING CO.,
11 John Street, cor. Broadway, New York

Commence

N. B.—This subscription will be billed concurrently with your Jewelers' Circular subscription. It can be stopped at any time.

Please enclose your business card or printed address

190

Send "THE OPTICAL REVIEW" to my address until otherwise ordered, for which I agree to pay **50 cents a year** as a special introductory combination price with my subscription to the JEWELERS' CIRCULAR-WEEKLY.

Name

Street

City

State

INSTRUMENTS.) SOLIDARITY WATCH CASE Co., Brooklyn, N. Y. Filed Feb. 13, 1908. Used 10 years.



Particular description of goods.—Watch cases.

Ser. No. 32,749. (CLASS 27. HOROLOGICAL INSTRUMENTS.) SOLIDARITY WATCH CASE Co., Brooklyn, N. Y. Filed Feb. 13, 1908.



Particular description of goods.—Watch cases.

TRADE-MARKS REGISTERED MARCH 31, 1908.

68,364. CERTAIN JEWELRY. C. A. MARSH & Co., Attleboro, Mass. Filed April 15, 1907. Serial No. 26,720. Published Jan. 28, 1908.

68,369. SILVER-PLATED FLAT WARE, HOLLOW WARE AND TABLEWARE. WM. A. ROGERS, LTD., Toronto, Ont., Canada, and Niagara Falls, N. Y. Filed May 25, 1905. Serial No. 6,565. Published Nov. 7, 1905.

BRITISH PATENTS.

ABRIDGMENTS OF SPECIFICATIONS, 1906, FROM *The Illustrated Official Journal.*

ISSUE OF MARCH 16, 1906.

26,515. BROOCH PINS. C. T. COOKE, London. Nov. 22.

Hook-shaped brooch pins as described in Specification No. 22,867, A.D. 1896, are hinged at one

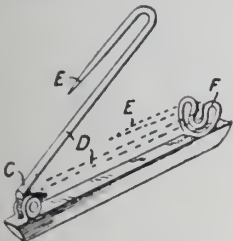

end C and secured by a suitable catch F at the other. The bent end E of the pin may be bent inwards into contact with the main portion D.

26,524. TIME-ALARM SIGNALS. G. C. MAAS, Isleworth, Middlesex, and G. H. COWING,

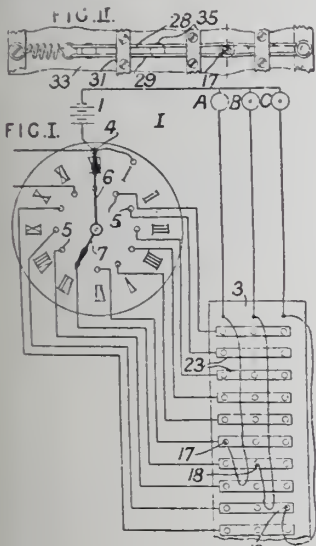

Ellesmere, Great Yarmouth. Nov. 22. Period of granting patent not yet expired.

In an electric time-alarm signaling-system for use in hotels, etc., the hour-hand 7 of the clock moves over a series of contacts 5 connected respectively to the bars 23 of the switchboard 3,

which bars can be connected by the flexible plugs 17, 18, 19 to the bells A, B, C of the rooms to be called. The hour and minute hands are electrically connected, and complete the alarm circuit from the battery 1 through the minute-contact 4, hands 6, 7, hour-contacts 5, corresponding bar 23, plug 17, and bell A back to the battery. This circuit is thus only completed when the minute-hand engages the contact 4. If it is desired to actuate the alarm at the quarter or half hours, additional contacts are provided for engaging the hour-hand, and also for the minute-hand, all the minute-hand contacts being connected in series. Fig. 11. shows the construction of one unit of the switchboard 3. The two parallel wires 28, 29 pass through notches in the strips 31, and are connected by plugs inserted in the holes 35 in the front 33 of the switchboard.

26,608. TIME CHECKS FOR GAMES. O. STREYER, Dresden, Germany. Nov. 23.

A clock for recording the time that a billiard table is in use is mounted in a case g, and works whenever the balls are out of the case, but is stopped when the balls are returned. The balls are inserted into the case through an opening I.

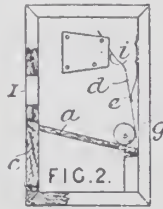

The case is formed with an inclined hinged bottom a, which guides the balls so that they press on a bent spring d connected to another spring e, and cause the spring d to engage the balance-wheel i of the clock. When a lid c is opened, the bottom a falls and allows the balls to run out, and at the same time the clock is freed from the spring d. Advertisements are placed, or fixed under glass, on the casing.

Complete specifications accepted March 11, 1908. 1907.

5,585. SAFETY-PIN FOR BROOCHES. EVANS & GOODE.

7,271. FOUNTAIN-PEN. WEGUELIN.

23,603. ELECTRIC WINDING-GEAR FOR CLOCKS. BOLLT.

Applications filed March 2 to March 7, 1908.

4,670. SAFETY-PIN. EDWARD BROWN, Aston.

4,689. ELECTRIC CLOCK SYSTEM. A. R. UPWARD, London.

4,729. SEPARABLE BUTTON. A. F. RICHTER, London. Complete specification.

4,827. ENGRAVING MACHINE. J. A. McLANE, London. Complete specification.

4,828. COMB. ROBERT THOMAS and FERDINAND CRASSER, London.

4,840. FOUNTAIN-PEN. CONWAY, STEWART & Co., London.

4,867. AUTOMATIC CLOCK-WINDING MECHANISM. ONE YEAR ELECTRIC CLOCK Co., GRENCKE & LAZARUS, London. Complete specification.

4,899. JEWELLED ORNAMENT. ETHEL M. COOK, Manchester.

4,904. TIME-RECORDER. C. H. GUEST, Derby.

4,919. JEWELRY FASTENING. ALFRED NOEL, London.

5,019. BRACELET SECURER. CHARLES DREYFUS, London.

5,027. BOW-FASTENER. LARKAN, DUNN & Co., London.

5,054. ELECTRIC CLOCK. JAMES NEALE and EDWIN POWELL, London. Complete specification.

5,090. BUCKLE. MAX RUBIN, London. Complete specification.

5,119. SPOON. JOSEPH LYTLE, Chancery Lane, London.

5,121. STUDS. PERCY AVERY, London.

5,147. STUD. SYDNEY GRIFFITH, Birmingham.

5,198. PLATING PROCESS. KARL MIELE, London.

5,210. HAIR-PIN. JULIUS KELLER, Walthamstow, Essex.

UNITED STATES PATENTS THAT HAVE EXPIRED.

[Reported especially for THE JEWELERS' CIRCULAR-WEEKLY by R. W. Bishop, Patent Attorney, Washington, D. C.]

Issued March 31, 1891.

449,103. BRACELET. CARL BACHEM, Pforzheim, Germany.

449,119. METAL CASED BOTTLE. Z. T. HALL, Philadelphia, Pa.

449,141. SUSPENDERS. W. J. STEWART, Williamsport, Pa.

449,182 and 449,183. PROCESSES OF MAKING SEAMLESS HOLLOW WIRE. C. R. SMITH, Providence, R. I., assignor to the C. R. Smith Plating Co., of Kentucky.

449,255. WATCH-BOW FASTENER. EMIL KLAHN, Jersey City, N. J., assignor to the Keystone Watch Case Co., Philadelphia, Pa.

449,295. FOUNTAIN-PEN. H. T. REED, Chicago.

449,310. WATCHMAKER'S PLIERS. E. E. COBLE, Elizabethtown, Pa.

449,370. TRAVELER'S WATCH CASE. E. A. LAUTEN, Mount Vernon, assignor to Albert Wittnauer, New York.

449,428. METHOD OF MAKING SEAMLESS PLATED WIRE. I. F. PECK, Providence, R. I.

449,499. POCKET-KNIFE. WILLIAM SCHMACHTENBERG, New York.

449,531. OPERA-GLASS HOLDER. J. U. GEROW, Brooklyn, N. Y.

449,605. EYEGLASSES. W. C. WESTAWAY, Decorah, Ia., assignor of one-half to H. C. Goddard and G. I. Leonard, same place.

449,648. BUTTON-FASTENER. H. S. ROCKWOOD, Providence, R. I. assignor to the Holmes Mfg. Co., same place.

Designs issued March 27, 1894, for 14 years.

23,149. COVER-DISH. C. E. HAVILAND, Limoges, France.

23,150. HOLDER FOR TOOTHPICKS. JOHN LUDWIG, Erie, Colo.

Designs issued April 2, 1901, for 7 years.

34,305. BADGE. C. G. BRAXMAR, New York.

34,308. NECKTIE-FASTENER. OTTO KRAUS, New York.

34,309. CAP FOR BUTTONS. G. E. ADAMS, New Britain, Conn.

34,310. SPRING-SUPPORT FOR HAT-PIN ORNAMENTS. A. A. McRAE, Attleboro, Mass., assignor to McRae and Keeler, same place.

34,315. KNIFE-HANDLE. R. J. MCKAIN, Philadelphia, Pa., assignor to Simons, Bros. & Co., same place.

Registration of Trade-Marks and Trade Names in Peru.

OUR Consul-General at Callao, Samuel M. Taylor, calls attention in the following report to the need of registering trade-marks in Peru:

The Peruvian law permits the registration of any trade-mark or trade name not hitherto registered in Peru. The effect of this is that any person can register a mark or name that he has no proprietary interest in, to the exclusion of the real owner, provided he is first in making application. Having registered he may manufacture a spurious article under this mark or name, while the genuine article cannot be introduced at all; or he may compel the rightful owner to purchase his registered rights at an excessive price. Registration is an easy matter and should not be neglected.

Fay R. Smith, New London, Wis., has bought the stock of U. S. Briggs, Manawa, Wis., through a trade. Mr. Smith will continue the business at Manawa as a branch store.

Waltham Watches

The history of the WALTHAM WATCH COMPANY is the history of watch manufacturing in America. More than half a century ago this Company introduced a new principle in the construction of watch movements, and has ever since applied the most advanced methods, producing always the best watches in the world. The WALTHAM WATCH COMPANY has built within its own walls the marvelous machinery employed in making the 15,000,000 Waltham watch movements now in use

Waltham Watch Company

WALTHAM, MASS.



The Terminal Curves of the Balance Spring and the Adjustment of Watches.*

ONE of the worthiest efforts to which horologists of all ages have devoted their attention has been that of making the rate of a watch as uniform as possible. For almost a century there had been in existence nu-

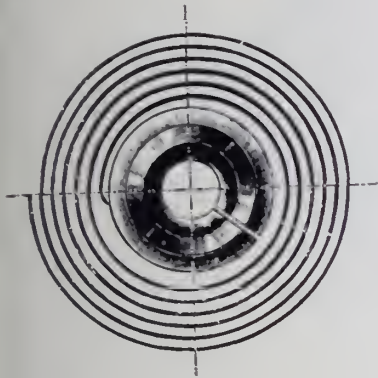

FIG. 1.

merous public clocks, provided only with an hour hand, and on which the time could not be read closer than to about five minutes. Nowadays we demand from clocks,



FIG. 2.

as well as from watches, a rate regulated to the second. For scientific researches there are even instruments with which

*Lecture delivered by L. Strasser, at Dortmund, on the occasion of the general assembly of the Association of Watchmakers for the Rhine province and Westphalia, on the subject of terminal curves of the balance spring and the adjustment and regulation of watches.

thousandths and ten-thousandths of a second may be distinguished. This minute comparison has been the result of a surprising advance in horology within a relatively limited period.

I wish to speak, on this occasion, of a brief and easily comprehensible method, employed in attaining so high a degree of perfection. In view of the limited time at my disposition, I shall restrict myself to the consideration of theoretical elements—a field in which one frequently encounters erroneous ideas. It is hardly necessary to state that in a watch in which precision of regulation is sought the depthing and the rate must be well conditioned. I shall not discuss details sufficiently well known for a long time to all horologists, but only the organs of regulation—that is to say, the balance and the balance spring.

If we observe the rate of a watch at first in a horizontal position, and then with the pendant on top, we shall notice as a rule an important difference. On noting the extent of the oscillations of the balance we shall find that they are much shorter in the vertical position, ring on top, than in the horizontal position—a fact which is attributable to the increased friction of the pinions. Therefore, it has been first of all considered reasonable that to obviate this difference it was only necessary to diminish, as far as possible, the difference in friction between the two positions. But the results have proved that this supposition is erroneous.

If we observe the same watch in different vertical positions—with the ring on top, ring to the right, to the left, at the bottom—we find that the difference varies in each position, although the friction on the pivots should be the same. It shows that friction of the pivots cannot be the cause of irregularities in the rate. Suppose, now, that the center of gravity of the balance falls outside of its axis, and we decide immediately that its influence on the rate of the watch must be different in the various positions, because the center of gravity occupies different positions. The irregular differences in the horizontal position and in the various vertical positions might be explained by this fact.

But if the balances are exactly in poise in the watches this displacement of the center of gravity must be sought elsewhere, and it is natural that it should proceed from the balance spring.

When the center of gravity of the balance spring falls outside of its axis it will necessarily exercise different influences in the various positions of the watch, and this explains the variations in the differences. Ma-

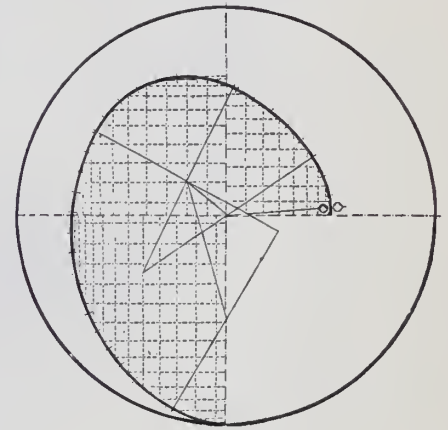

FIG. 3.

terial changes in the form of the balance spring at the time of its oscillation cause an important displacement of the center of gravity, which exercises a different influence, also in the horizontal position, according to whether the oscillations are re-

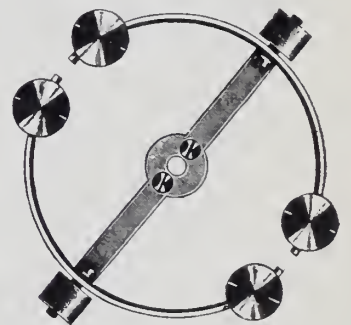

FIG. 4.

stricted or extended. Now, by a rational selection of the point of interior attachment of the balance spring it is possible to effect an almost complete suppression of the displacements of the center of gravity in the vertical position of the watch—a measure



In every country on the globe there is a demand for the

ELGIN WATCH

Just now, in response to extensive advertising, the demand is for the G. M. Wheeler Movement.

To take advantage of this popular tide as it runs, every jeweler should have the G. M. Wheeler grade Elgin Watch in three sizes, 18, 16 and 12—particularly the smaller sizes in the thin model.

See jobbers list for prices or write the Company.

Send for Elgin art booklets, "Timemakers and Timekeepers" and "The Watch."

ELGIN NATIONAL WATCH COMPANY,

Factories: Elgin, Ill., U. S. A.

General Offices: 131 Wabash Ave., Chicago.

New York Office: 11 John St.

San Francisco Office: 794 Market St.

which, at the same time, obviates the irregularity in the differences of rate.

As may be seen in Figs. 1 and 2, the first balance spring is coiled towards the right from the center, the second is turned towards the left. When we place to the left the point of attachment of the balance spring coiled to the right, and on the right that of the spring coiled to the left, the influences of the center of gravity will be found to be almost equalized in the position with the pendant on top. By observing this very simple rule we obtain a very good rate, even in a simple watch, without a Breguet spring.

The best position for the point of interior attachment may, moreover, be determined in the following simple manner. In observing, first of all, the rate in a horizontal position, then in the various vertical positions, we finally arrive at a position in which the rate is approximately the same as in a horizontal position. Let us suppose it to be that in which the figure 4 is on top; it is necessary in this case to displace by a third of a turn either the point of interior or that of exterior attachment (since the distance from 4 to 12 represents a third of a turn), and that is in the direction going from 4 to 12 seen from the side of the movement.

But for a watch of precision the choice of the point of attachment alone does not fulfill the purpose. It is required of such a timepiece that its rate shall be regular, not only in one vertical position but in all positions. To obtain this result, the balance spring must be provided with terminal curves.

Engineer Philipps has made the balance spring the subject of the closest study and has found that in imparting a certain form to the terminal curves the center of gravity of the balance spring falls on the axis of the balance, and that in this case the watch displays the smallest possible difference in rate in all vertical positions. Without going into the lengthy and difficult mathematical details, we may consider a very simple rule as to whether a terminal curve answers to requirements—that which is represented in Fig. 3. We divide it into a certain number of parts, in such a manner that we might almost consider as a straight line each separate division, and from the center of these parts we trace horizontal and vertical lines, prolonged to the center line and at right angles towards each other.

When the total of all the horizontal lines on the right is equal to the total of all the horizontal lines on the left; when, in addition to this, the sum of all the ascending lines, less that of the descending lines, is equal to the square of the radius of the balance spring, divided by the distance between the points of separation, the curve meets the requirements of the theory. The form of the balance spring must be modified until it complies with these conditions. The design shows, at the same time, a new construction of the terminal curves. This construction, which I have adopted for the first time, possesses various advantages. The curve only consists of arcs of two different radii, of which the first is equivalent to the exterior radius of the balance spring, in such a manner that the largest portion of the curve does not require special bending.

In view of the imperfection of all human work, it has, however, been found impossible to make the rate of a watch uniform in every position. There are still other influences affecting the oscillation through the escapement, which I shall take up at once.

Let us divide an oscillation of the balance spring into a rising oscillation, during which the spring is tightened and a descending oscillation, during which it uncoils. Scientific investigation, confirmed by observation, shows that at the time of the descending oscillation, for instance, the unlocking resistance in a lever watch retards the length or duration of the oscillation, while an impulse shortens it. During the rising oscillation the effect produced is the opposite. But in view of the fact that the unlocking resistance concurs with the descending oscillation and that the greater proportion of the impulse concurs with the rising oscillation, the escapement causes, as a rule, a restriction of the duration of the oscillation of the balance, and this effect is greater on the large than on the small oscillations. The result, in watches provided with terminal curves, is that as a rule the large oscillations are more rapid than the small ones, and that when they are large the watch gains.

This influence cannot be compensated for in any way by means of the balance spring, if it is demanded that the rate shall be as uniform as possible in all the vertical positions, but it is compensated for to a certain extent by the balance. We know that all accurate watches are provided with a compensation balance. The rim of this balance is cut open at two points opposite to one another. It is loaded in addition with screws or weights and centrifugal force tends to force outwards the rims of the balance. The greater the oscillation of the balance—that is to say, the more rapid its movement, the greater the influence of the centrifugal force.

Hence the centrifugal force alone has for its effect to make the large oscillations slower than the short ones. The influence of the escapement I have just stated makes itself felt in the opposite direction, so that there is a partial compensation. Accident may lead, as a fact, to the counterbalancing of these two influences. Every manufacturer knows by experience that among the various calibers of watches it happens that with some adjustment to position is effected much easier than with others. The favorable conditions in this respect may be due to the above-stated circumstances.

We have thus far confined our attention to the balance and will now pass to the results of compensation. Everybody knows that the object of compensation is to obviate the effects of variations of temperature on the rate of a watch. For this purpose, the rim of the balance is made up of two metallic rings, joined together, the outer one expanding more readily than the inner one under the influence of heat. The result is therefore that with a rising temperature the rim of the balance is curved outward and with a lower temperature it curves inward. It is supposed very often that this arrangement neutralizes the effects of temperature on the dimension of the balance and the length of the balance spring.

But in reality this influence is exceedingly

small. A much more important effect is exercised by the modification of the coefficient of elasticity of the balance spring, which decreases with cold and increases with heat. The balance spring therefore becomes, so to say, softer under the influence of heat and harder under that of cold, so that the watch in the first case loses and in the second case gains. The screws or the weights will have to be shifted until compensation is obtained. A movement or increase of the weights towards the free end of the rim increases the effect of compensation, just as its decrease lessens this effect.

Now theory and experience have demonstrated that when the rate of a watch is perfect at extreme temperatures, its rate will be altogether different at mean temperature. This is known as the "middle temperature error." Its importance has given rise to the manufacture of a large number of auxiliary compensations. Theory and experience have demonstrated, in addition, that this error is much greater where the screws or the weights are near the free end of the rim.

With a view of obviating these disadvantages, Professor Guillaume, who is known to you through his experiments with nickel-steel, has constructed a compensation balance (Fig. 4), the body of which is composed of nickel-steel, in place of the ordinary steel, and in which it is possible, with an adequate compensating effect, to bring the weights or mass as near as possible to the rigid part of the rim and thus to eliminate, almost entirely, the secondary effect of the compensation. The favorable results obtained at the latest tests of chronometers were due, in large part, to this invention.

As we are speaking of nickel-steel I would call your attention to another important use for this metal. Professor Guillaume has succeeded in producing another alloy of nickel-steel, possessing a coefficient of elasticity insensible to variations of temperature, and from this metal balance springs have been made with which the employment of a compensation balance is rendered superfluous. It is possible that some day the manufacture of these balance springs may become so successful that we shall be able to virtually do away with the compensation balance, even for the most accurate watches.

Regulating clocks have also attained a higher degree of perfection, thanks to the utilization of nickel-steel. M. Professor Guillaume has succeeded in discovering an alloy that is almost insensible to expansion caused by heat.

Among the \$300 worth of goods stolen from the store of Nathan Kline, McKeesport, Pa., recently, were 17 watches and watch chains, bracelets and lockets. There is no clue to the thief.

Two thieves who robbed the firm of M. Waldhorn & Co., 343 Royal St., New Orleans, La., are supposed to have gone to California, and according to the Pinkerton Detective Agency are believed to be in Santa Clara County in that State. A reward of \$1,000 has been offered for the recovery of the jewelry and the arrest of the thieves. About 110 rings, valued at \$7,648, were stolen.

Jas. Boss Stiffened Gold Watch Cases

(Guaranteed for 20 years)

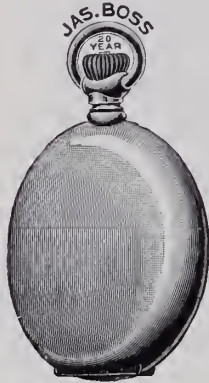

B - 015



Trade-Mark in back



Trade-Mark in cap



B.205

☞ Superiority in construction.

☞ Beauty in design.

☞ Variety in ornamentation.

☞ Perfection in execution.

☞ Have placed this line in the lead in popular favor.

☞ Nothing cheap about it except the price.



B - 1912



B.2033

Sold by all leading jobbers



B.2042



D - 1307

The Keystone Watch Case Co.

PHILADELPHIA

New York
Chicago

Boston

Cincinnati
San Francisco

Results of the Competitive Trials of Chronometers at the Astronomical Observatory of Neuchatel.

AT the instance of the director of the Cantonal observatory the government of Neuchatel has decreed that the prizes offered during competitive trials of chronometers are to be awarded as follows:

1.—PRIZES AWARDED TO MANUFACTURERS.

A.—Series of prizes for the best six chronometers for torpedo boats and pocket use of the first class:

- (1) Ch. E. Tissot, of Locle, 18.1; (2) Paul D. Nardin, of Locle, 16.8; (3) Paul Ditisheim, of Chaux-de-Fonds, 15.6; (4) G. Favre-Jacot & Co., of Locle, 15.3; (5) Fabrique des Longines, of St. Imier, 12.1.

B.—Marine Chronometers:

Four first, three second and two third prizes were awarded to Paul D. Nardin, of Locle.

C.—Torpedo Boat Chronometers:

- First prizes*—(1) Ch. E. Tissot; (2) Paul D. Nardin. *Second prizes*—(3) Fabrique des Longines; (4) Paul Ditisheim; (5) Paul Buhre, of Locle. *Third prizes*—(6) Fabrique des Longines; (7) Girard-Perregaux & Co., of Chaux-de-Fonds; (8) Ch. E. Tissot; (9) Paul Ditisheim; (10) Girard-Perregaux & Co.

D.—Pocket Chronometers of the First Class:

- First prizes*—(1) Paul Buhre; (2) Ch. E. Tissot; (3) G. Favre-Jacot & Co.; (4) Charles Huguenin, of Locle; (5) Ch. E. Tissot; (6) Paul D. Nardin; (7) Paul Ditisheim; (8) Paul D. Nardin; (9) Girard-Perregaux & Co.; (10) Paul D. Nardin; (11) G. Favre-Jacot & Co. *Second prizes*—(12 to 27) Six to Paul D. Nardin, four to Paul Ditisheim, three to Ch. E. Tissot, three to G. Favre-Jacot & Co. *Third prizes*—(28 to 33) Four to G. Favre-Jacot & Co., one to Paul D. Nardin, one to Paul Ditisheim.

E.—Pocket Chronometers of the Second Class:

- First prizes*—(1) Eugene Fassnacht, of Bienne; (2) Fabrique des Longines; (3) Paul D. Nardin; (4) Fabrique des Longines; (5, 6 and 7) G. Favre-Jacot & Co. *Second prizes*—(8 to 14) Two to Paul D. Nardin, three to the Fabrique des Longines, one to Ch. Stoeckly, of Locle, one to G. Favre-Jacot & Co.

2.—PRIZES TO ADJUSTERS.

- The list of prizes for the adjustment of the six best torpedo boat and pocket chronometers of the first class is as follows: *First class*—(1) Ch. Ferd Perret, of Locle; (2) Charles Rosat, of Locle; (3) Henri Rosat and Henri Gerber, of Locle; (4) Aug. Bourquin, of Chaux-de-Fonds; (5) Aug. Vuille-Roulet, of Saint-Imier.

HONORABLE MENTION FOR ADJUSTERS OF CHRONOMETERS.

A.—*Marine chronometers*—Henri Rosat and Henri Gerber, nine chronometers.

B.—*Deck chronometers*—Charles Ferdinand Perret, two; Aug. Vuille-Roulet, two; Aug. Bourquin, two; Ch. Wolfensberg, of Locle, two; H. Rosat and H. Gerber, one; Charles Rosat, one.

C.—*Pocket chronometers, first class*—H. Rosat and H. Gerber, 10 chronometers; Charles Rosat, nine; Aug. Bourquin, six;

Ch. Ferd Perret, five; Charles Huguenin, of Locle, two; Aug. Laberty, of Locle, one.

D.—*Pocket chronometers, second class*—Aug. Vuille-Roulet, five chronometers; Charles Rosat, four; H. Rosat and H. Gerber, three; Eug. Fassnacht, of Bienne, one; Ch. Stoeckly, of Locle, one.

The Cantonal government has set the lowest figures of classification for awarding prizes resulting from competitive trials of chronometers as follows:

(1) For the list of prizes for manufacturing watches, 12.0.

(2) For marine chronometers, 13.0.

(3) For deck watches (torpedo boats), 11.0.

An Automaton Clock Made by a Pennsylvania Watchmaker.

THE clock illustrated herewith was made by Isador Bauer, Weston, Pa. It shows a number of automatons who are busily engaged at work in a workshop.

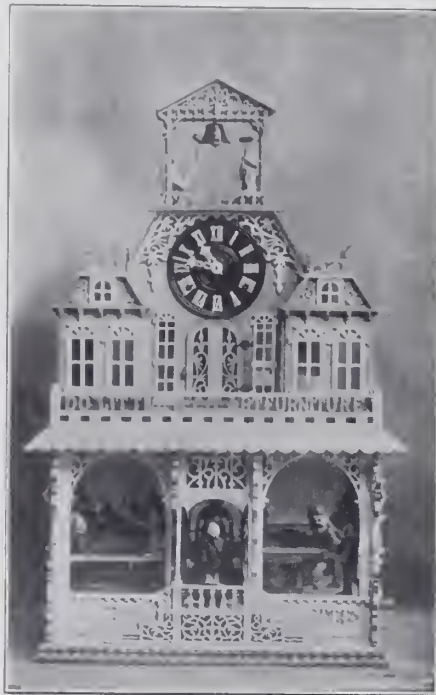

AUTOMATON CLOCK MADE BY I. BAUER.

These little wooden men are depicted in the act of sawing, planing, turning the grindstone, sharpening tools, striking the anvil, pulling the bellows near the forge, etc., etc. Every half-hour two men strike a big bell, which is in the top of the tower.

The foreman or superintendent of the factory then appears at the center door and a pleasing melody is heard. The work is an ingenious conception, and evinces much horological and mechanical genius.

A Clever Window Attraction.

AN exceptionally ingenious window attraction is shown herewith. It consists of an American alarm clock with a balance and a balance spring, placed in a flat position with center posts pointing upward.

Fitted upon the tube of the hour wheel is a disk, B, with cuplike attachment, on

the outer face of which are laid out in place of the 12 hours usually marked on a flat dial, figures, which resemble those on the upright outer side of this cuplike attachment. Another similar cuplike attachment is placed firmly on a special extra long center post of the clock movement, which post rotates the canon pinion in the usual manner. On the outside and

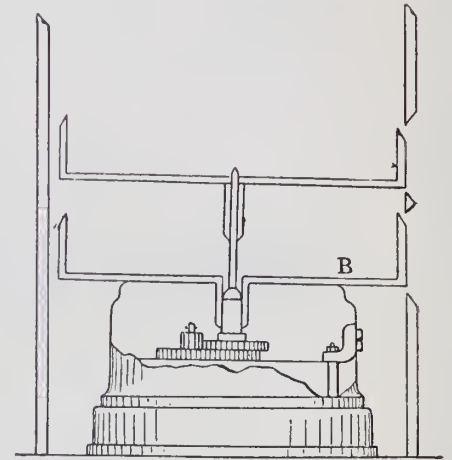

FIG. 1.

upright rim of this second cup are laid out the 60 minute marks. (Fig. 1.)

Conceal the clock movement so modified in a box made of wood, pasteboard, or any other material. Place near the box a piece of cardboard bearing any inscription.

The essential point is that the front of this structure be pierced with two openings through which the clock in turning may



FIG. 2.

show the hour and minute (Fig. 2). This completes the whole, and it offers only the additional facility, that it can have the external appearance changed any number of times by substituting any new subjects which may interest the public.—*Revue Internationale de l'Horlogerie.*

E. J. Peterson, Galesburg, Ill., retired from active business about a week ago, after an uninterrupted business career extending over a period of 58 years, 27 of which were spent in Galesburg.

Brooch and Case Combined

Cannot Be Lost
Will Not Pull or Wear Off

Dubois

Safety Chatelaine Brooch Watch

Patents Pending in U. S. and Foreign Countries.

MERITS—Holds the watch firmly and securely, thus preventing the movement from being jarred, as there is no swinging or bobbing up and down while the wearer is walking or running. Protects both the case and garment from wear.

UTILITY—It can be raised so as to read the time, and reversed to have either the dial or back facing front, without removing brooch pin or watch from the garment. Can be worn on the shoulder, belt, chain or fob.

ARTISTIC AND PRACTICAL—The only brooch and watch combined. Affords absolute security, as it has a safety catch. Nothing to wear out, as it works on friction bearings. Eliminates the possibility of loss of the watch owing to either bow, hook, swivel or link wearing out, breaking or coming apart, as in the old style chatelaine. Does not interfere with either winding or setting of movement.

Licensed under Wachter Patent Ball-Bearing Bow

Dubois Watch Case Co.,

21 and 23 Maiden Lane
NEW YORK CITY



SIDE VIEW OF WATCH.



RAISED VIEW.



BACK OF WATCH.

SETH THOMAS CLOCK COMPANY

Established 1813

MANUFACTURERS OF SUPERIOR TIMEPIECES OF ALL SIZES, STYLES AND PRICES, FROM AN O SIZE LADY'S WATCH TO 40-FT. DIAL TOWER CLOCK—largest in the world (See page 95 of last issue). The greatest variety of timepieces made by any company.

OUR PRODUCT CONSISTS OF

Cabinet Clocks in Mahogany, Flemish and Golden Oak. ¶ Colonial and Arts and Crafts designs. ¶ Hall or Grandfather Clocks, chiming on Cup Bells and Cathedral Gongs. ¶ Regulators and Precision Clocks of great variety and prices. ¶ Marble Dial Hanging Clocks of several patterns and sizes, also fitted with Bronze numerals. ¶ Gallery, Lobby and Double-Dial Clocks for large offices. ¶ Perpetual Calendar Clocks, for mantel and hanging, in various designs and finishes. ¶ All styles of small Office Clocks, 8, 15 and 30-day. ¶ A complete line of jeweled Chronometer Levers in brass and wood cases, also Low Priced Lever Clocks. ¶ "Eight Bells" or Boat Clocks in three designs. ¶ Our popular "Adamantine" line of Wood Mantel Clocks is made in White, Black, Golden Bronze, Mottled Green and Mahogany finishes, of many shapes and prices. ¶ Also Alarm Clocks in many styles and finishes.

EMPIRES OR GLASS REGULATORS

Our line contains every style necessary to suit all tastes. Made in Polished and Satin or Rich Gold, also Bronze, Verde Antique, Cut Glass and Onyx, some with convex fronts, fitted with 8 and 15-day movements. We make a large line of Bronze Art Nouveau Cases with Figures, Vases and Candelabra Side Ornaments to match; also many patterns of 1-Day Metal Novelties.

WATCHES

0, 6 and 18 sizes, including high grade Railroad movements.

TOWER CLOCKS

Street or Post Clocks and Tower Clocks are made in all sizes to fill every possible want.



AUTOMATIC 8-DAY LONG ALARM CLOCKS

That do not require any attention at night. Will be ready in May. Ask your Jobber for printed matter regarding this new up-to-date alarm.

Catalogues and printed matter may be obtained from your jobbers or from us direct.

51 Maiden Lane
NEW YORK

SETH THOMAS CLOCK COMPANY

70 Wabash Ave.
CHICAGO



The Favorite Movement with both Trade and Public

The Omega Movement

stands in high favor with the trade, and is constantly increasing in popularity for the reason that the public is quick to appreciate its merits.

The man who carries an Omega is proud of it and misses no opportunity to sound its praises to his friends. He finds it invariably and uniformly reliable. He learns to depend upon it and it never abuses his confidence.



Ω
OMEGA

Adaptable, Interchangeable, and Suited to all Requirements

The Omega is made in all sizes to fit regular American cases, besides a number of Swiss sizes. Every part is interchangeable, and all are made with lever escapements, double roller and pendant set. There are six different grades—from seven jewels to twenty-one jewels—adjusted to heat, cold, and five positions.

EDMOND E. ROBERT
3 Maiden Lane New York

WESTERN SELLING AGENCY
Omega Watches
Heyworth Building, Chicago

CROSS & BEGUELIN
31 Maiden Lane New York

A Page from Watch History

The picture at the left shows the old Roman tower in which the **Vacheron & Constantin** watch factory was located in the early days of watch history.



The picture at the right shows the present factory, built in 1875, and remodeled some years ago.

These illustrations not only mark the progress of the **V. & C.** watch, but of the entire watch-making industry, for the **Vacheron & Constantin** was recognized as the standard of excellence when the watch was first placed on the market in 1785, and is so recognized to-day.

It has always led in correct, scientific principles, in absolute accuracy, and in all the various improvements in watch manufacture since the establishment of the house. It has captured many first prizes in international timing contests, and its unquestionable superiority renders it the most salable and profitable high grade watch that the dealer can offer his customers.

The **V. & C.** line embraces every variety of adjusted watches, complicated watches, extra flat, ultra flat, and enameled, carved and jeweled watches.



EDMOND E. ROBERT, Sole Agent, 3 Maiden Lane, New York

New England Watches

¶ There is something that goes with a *New England* shipment that you won't find listed when you look at the invoice.

¶ It's the mighty force of the great *New England* organization, with its special Retailers' Aid Department backing every dealer in *New England* Watches.

¶ Write for particulars.

The New England Watch Co.

Waterbury, Conn.

Chicago

San Francisco

Repeated Triumph of the Patek, Philippe & Co. Watches

RECORD of 1907-1908

Kew Observatory Trial of Watches and Chronometers

The First, Second, Sixth, Seventh, Eighth and Ninth
BEST RECORDS

Geneva Astronomical Observatory Timing Contest

53 out of 101 Prizes, namely:

The only First Prize for Best Average Running among Makers

4 First Prizes out of 5

Including all the highest and the nearest to perfection ever obtained by a portable timepiece

10 Second Prizes out of 18

9 Third " " 17

12 Fourth " " 26

7 Honorable Mentions " 18

10 Single Prizes " 17

19 Manufacturers Participated

Awarded Hors Concours (Beyond Competition): Milan, 1906; St. Louis, 1904; Paris, 1900; Paris, 1889; Antwerp, 1885; Zurich, 1883.
Gold Medal: Nuremburg, 1905; London, 1885; Calcutta, 1883; Croningen, 1880; Paris, 1878; Vienna, 1873; Paris, 1867; Paris, 1855;
London, 1851; Paris, 1844. Diploma of Honor: Nice, 1883.

68 Nassau Street, NEW YORK

GENEVA, SWITZERLAND

THE ROTATOR

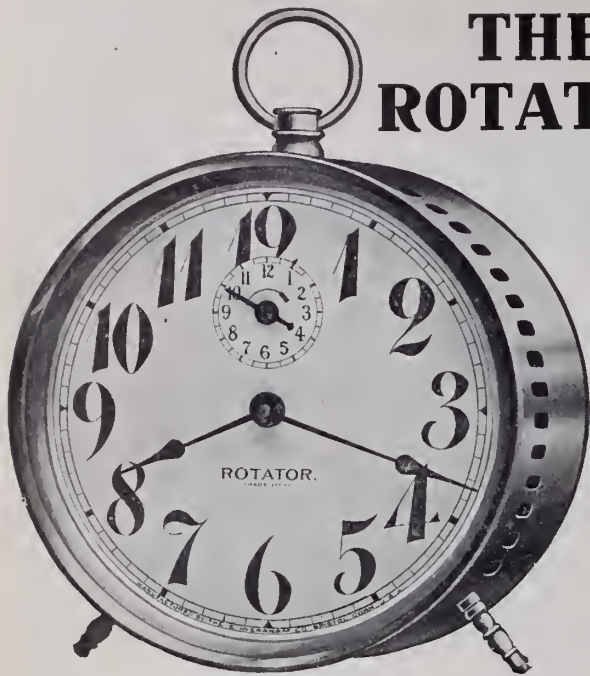

FRONT VIEW

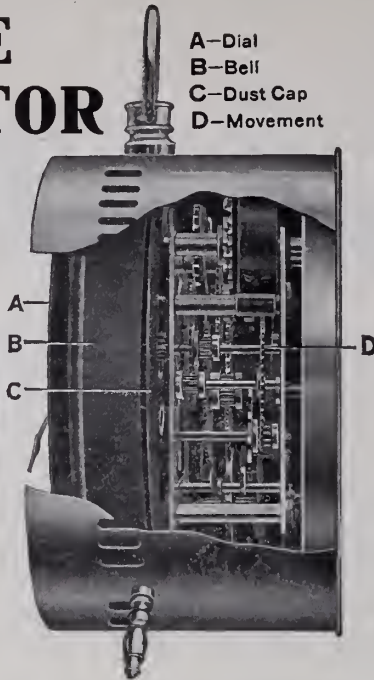

INTERIOR VIEW

☐ Highest Grade, Lowest Price, Alternating Alarm. Rings at intervals of fifteen seconds with manual stop. Largest and loudest bell of any nickel alarm clock made. Bell contained entirely within the case. Movement fully protected from dust by "Dust Cap" shown in cut.

☐ Sold by all leading jobbers. If your local jobber does not handle the ROTATOR, write us.

THE E. INGRAHAM CO.
BRISTOL, CONN.

GUN METAL



WATCHES

Positively the most interesting line of moderate priced Gun Metal, Nickel, Gilt, Enameled, Silver and Gold Watches. GUARANTEED THIN - MODEL WATCHES.

Does Your Stock Move?

Drop us a line. We will present to you a new proposition to increase your sales. We furnish you the whole outfit free of charge, delivered at your store.

American-Swiss Watch Co.
1 MAIDEN LANE, NEW YORK

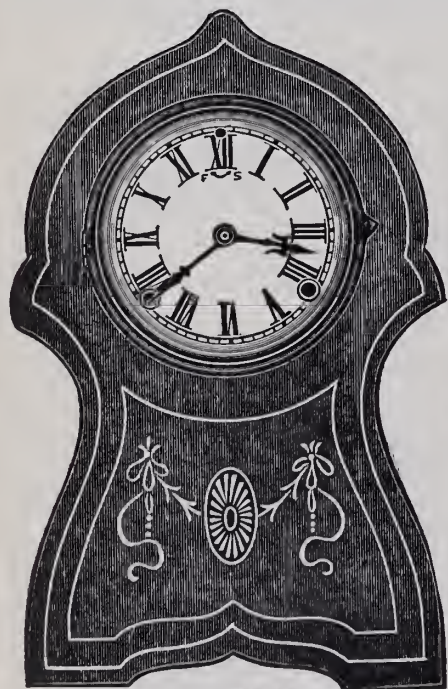

MANCHESTER
Height 13¾ in. Width 8¾ in.

SESSIONS CLOCKS

Superior Finish
Popular Prices

We have added a number of fine marqueterie cabinet clocks to our line which will interest you.

The Sessions Clock Company

FORESTVILLE, CONN., U. S. A.

New York Salesroom, 37 Maiden Lane

HALL CLOCKS



Elliott's Celebrated Tubular Chimes

HARRIS & HARRINGTON,

12 BARCLAY ST.,
NEW YORK

Sole Agents to the Trade for
J. J. ELLIOTT & CO.
LONDON.

JULES JÜRGENSEN
Watches and Chronometers

PARIS—"THE GRAND PRIX"—1900

SOLE
RUDOLPH & SNEDEKER
65 Nassau St., New York
AGENTS

THE Ægis Case

(PATENTED)

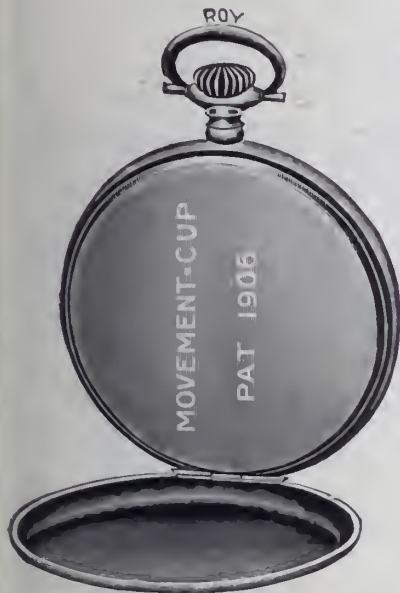

THE ÆGIS is a new creation in gold case making. The center and bezel are in one. Instead of having the ordinary Cap, this case is provided with a rigid metal movement Cup, held friction tight in position. This Cup gives protection to the movement such as cannot be secured with the conventional jointed cap, while dust is thoroughly excluded from the front by means of the one-piece center and bezel.

MADE ONLY BY

ROY WATCH CASE CO.

21-23 MAIDEN LANE
NEW YORK

San Francisco Office, 704 Market Street

New England Watch Repairing for the Trade

GEO. W. HYDE & CO.
101 TREMONT STREET
BOSTON, MASSACHUSETTS

Make a Specialty of Repairing
New England Watches

Work returned in one week, and guaranteed to be satisfactory in every respect. Recommended by The New England Watch Co.

Ball Watches

THE RAILROAD STANDARD

The Watch Inspector's Friend

WRITE TO-DAY FOR OUR DEALER'S PROPOSITION

Minneapolis, March 12, 1908.

Gentlemen:

Your 18 size "Official" No. 548110 arrived just in time to aid me with my watch inspection work, as my electric clock was out of commission for 23 days, during which time your watch varied only 4 seconds. Very respectfully,

L. L. WILLIAMSON.

Railway Watch Inspector
1717 E. Franklin Ave.

The Webb C. Ball Watch Co.

Ball Building
Cleveland

Railway Exchange
Chicago

Pacific Type Fast Express Engine for
New York - Boston Service.

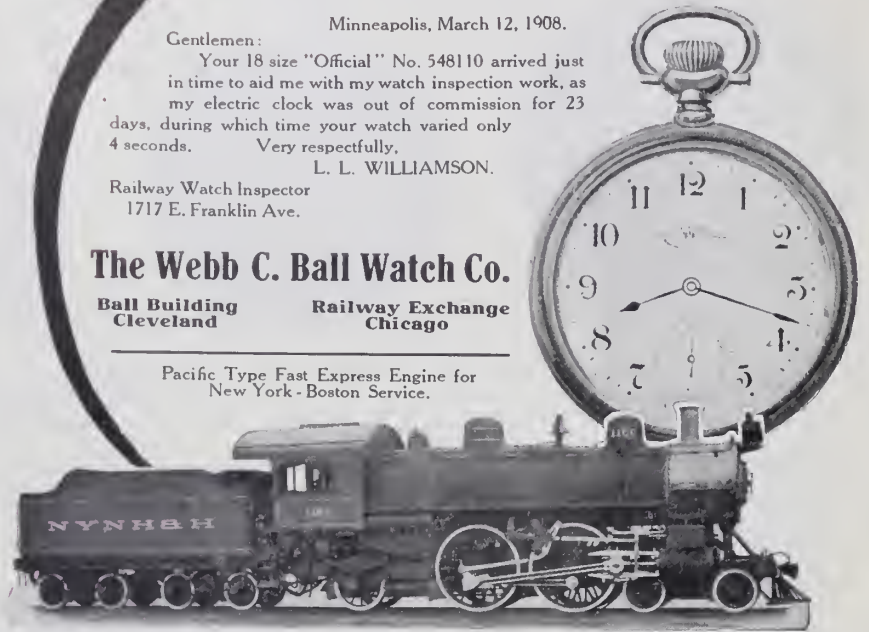

A.W.C.CO

A Trade Builder

An artistically decorated and inexpensive watch case that you can unconditionally recommend; of indisputable beauty and faultless construction. Singularly free from the technical defects common to most moderate-priced gold cases. Built to sell and last, two virtues that will attract and hold trade.

Sold by us directly to you



14K.

C-1460

American Watch Case Co.

9-11-13 Maiden Lane

New York

HOROLOGICAL DEPARTMENT

BRADLEY POLYTECHNIC INSTITUTE

Formerly Parsons Horological Institute

PEORIA, ILLINOIS

LARGEST AND BEST WATCH SCHOOL IN AMERICA

We teach Watch Work, Jewelry, Engraving, Clock Work, Optics. Tuition reasonable. Board and rooms near school at moderate rates. Send for Catalog of Information

WATCH REPAIRING

FOR THE TRADE

Careful, Reliable, Prompt Work. Trade References. Price List on Request.

A. D. PAPAZIEN

71-73 Nassau St., Cockroft Bldg.

NEW YORK

PRACTICAL COURSE IN ADJUSTING.

ALL JOBBERS OR JEWELERS' CIRCULAR PUBLISHING CO.

Published Price, \$2.50.

Special Reduced Price, \$1.50, Postpaid.

Buy Watches With Our Patent Ball-Bearing Bow Already on the Market

No watch case should be without it.

BEWARE OF IMITATION



Should your jobber not sell cases with these bows, write us and we will give you a list of jobbers who do.
Patented July 25, 1905; May 21, 1907. Other patents applied for.
Patented in foreign countries.

The Wachter Manufacturing Co.
HARTFORD, CONNECTICUT

WM. C. PENFOLD CO.

No. 35 MAIDEN LANE, NEW YORK

LARGEST EXCLUSIVE WATCH JOBBERS IN NEW YORK OF

Dueber-Hampden Watches Dueber Cases — Hampden Movements

A Complete Line Always on Hand. Mail Us Your Orders

WATCHES OF PRECISION.

Mathey Bros., Mathez & Co.

WATCHES DEMAGNETIZED



12 SIZE MOVEMENTS

Manufacturers and Importers of
Superior, Plain and Complicated Watches.

Sole Agents for

CHAS. H. MEYLAN.

SMALL WATCHES A SPECIALTY.

Brassus, Switzerland

21 MAIDEN LANE, NEW YORK.



12 SIZE SPLITS

Practical Course in Adjusting

Published Price, \$2.50
Special Reduced Price, \$1.50, Postpaid

All Jobbers or
Jewelers' Circular Pub. Co.

AT LAST!!

A WESTMINSTER CHIME Hall Clock

At a Popular Price

WESTMINSTER CHIMES

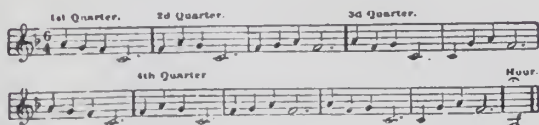

GENUINE MAHOGANY CASE
POLISHED MOVEMENT
WESTMINSTER CHIMES

ORNAMENTAL 12-INCH GILT DIAL
WITH SILVER-FINISH DIAL RIM

A FINE MAHOGANY HALL CLOCK AT A LOW PRICE

DESCRIPTION

These Hall Clocks are furnished with a superior finished eight-day spring movement, striking sections of the melody at each quarter and the full Westminster Chime, followed by striking the hours, the same as the famous London Chimes. We draw especial attention to the strike of these movements. The gongs are not spiral, and the sound is sonorous yet mellow and soft.

When these clocks are fitted with long tubular chimes, a separate striking attachment is used. These clocks reproduce the sound of the famous "WESTMINSTER CHIMES."



CLOCK No. 1

Genuine Mahogany Case
93" high, 21 1/2" wide, 12 1/4" deep
Five Chime Movement
Striking on Straight Rods

This Clock can be sold
at a Good Profit by Retailers
for 80 Dollars



CLOCK No. 2

Genuine Mahogany Case
89" high, 21" wide, 13 1/2" deep
Five Chime Movement
Striking on Nickel-Plated Hollow
Tubes.

This Clock can be Sold at
a Good Profit by Retailers
for 100 Dollars

SUSSFELD, LORSCH & Co.

PARIS, 21 RUE DE L'ECHIQUIER

37 MAIDEN LANE, NEW YORK

IMPORTERS OF CLOCKS

MANTEL CHIME CLOCKS, NOVELTY CLOCKS, CUCKOO CLOCKS, URANIA
400-DAY CLOCKS, FRENCH TRAVELING CLOCKS AND REGULATORS

Ask for Booklets and Circulars

STORE KEEPING DEPARTMENT

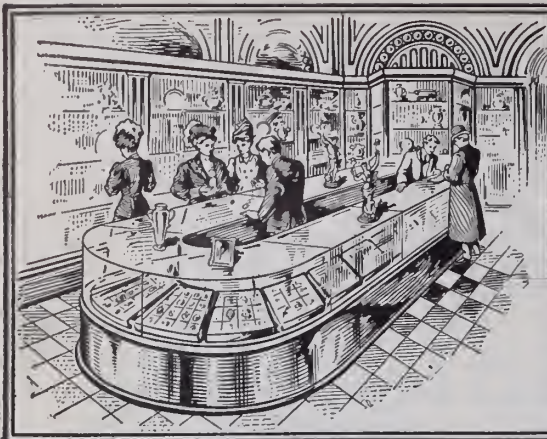

That this department shall prove mutually beneficial to our readers, it is desirable that the members of the trade generally communicate with **THE JEWELERS' CIRCULAR-WEEKLY** regarding any advantageous device or plan which they are utilizing in connection with their business.

The Best Arrangement of the Storeroom in Order to Get the Maximum Amount of Daylight.

WITH the exception of direct sunshine one hardly ever obtains too much daylight illumination for the efficient sale of goods, writes O. H. Basquin in the *Illuminating Engineer*. With respect to the other limit, namely, the least illumination which can be used to satisfaction, a great diversity exists among different classes of goods as well as in the preference of different salesmen in the same kind of merchandise.

No very definite rule can be given for the illumination required. In general the illumination must be greater for goods of fine texture, for those of dark color and for those in which the quality depends largely upon color and shape. For the examination of silk goods one needs a much stronger light than for that of horse blankets; the colors are likely to be darker, the texture itself is finer and more particular attention is given to the study of color in the one than in the other.

Goods which sell at high prices are generally given the preference with regard to illumination. Their quality should be such as to sustain closer scrutiny, and the purchasers of such goods should be made as comfortable as possible at the time of the sale. For the sale of tinware and for the larger articles of hardware a rather small illumination can be tolerated in the second case because of the coarseness of the goods, and in the first because of their bright surfaces.

A salesroom which is entered directly from the brightly illuminated street should have a better illumination than one which is entered through another salesroom. The reason for this has to do with the physiology of the patron's eye. When he is out doors where the illumination is great the pupil of his eye is contracted; as he enters the salesroom his pupil is still small, but slowly increasing in size as its owner attempts to look about. If one notices too great a change in illumination on going into a store an impression of gloom is given to the customer at the very time when he should be impressed with the cheerfulness and the general attractiveness of the salesroom. In going from one room to another in a large store this effect is practically lost, so that the illumination may be reduced as one goes farther from the entrance.

In determining upon the arrangement of a salesroom with respect to lighting fixtures, one tries to provide that illumination which accords best with the taste of the salespeople, with the needs of their customers and with the financial resources available for purposes of illumination. The man who makes this selection will do well to visit all the shops within reach where the same class of merchandise is sold, and in making this examination he must look at each shop from the standpoint of the prospective purchaser of goods. After critically comparing the illumination of a few shops in this way he will be better able to make a judicious selection of window fittings and to arrange his store fixtures to good advantage.

Very much depends upon the arrangement of the store fixtures within the salesroom. The room most easily lighted is one with a high ceiling, with perfectly plain walls unbroken by offsets of any kind, with white-washed walls and ceiling, and, finally, a room devoid of furniture. Such a room would be of little practical value unless it were for a board of trade or for some other purpose requiring no furniture. Such a room may, however, serve a useful purpose as the ideal toward which the actual room should be made to approximate as nearly as circumstances will admit.

The average American store has a high ceiling, is long and narrow and derives the most of its light from the window facing the street. The customary arrangement of the shelves for the storage of goods along the side walls, and extending sometimes up to the ceiling, is as good as one can desire. If the goods can be kept in drawers or boxes—as is the case in shoe stores—and if these drawers or boxes have white ends, the ideal condition is closely approximated.

The forming of alcoves by placing some of the cases transversely across the floor should, of course, be avoided. The counters should run parallel to the side walls, and if the store is so wide as to need another set of counters running down the middle, the shelving for the storage of goods between these central counters should be kept as low as possible. All dark-colored furniture should be avoided, from the

standpoint of illumination, and in the arrangement of fixtures the general attempt should be made to allow free access of the light from the windows to every part of the store where light is wanted. In this connection one must not neglect the diffused light from walls and ceiling; this is what makes ordinary daylight illumination so much more satisfactory than that due to artificial light, and it is for the lack of this diffused light that it is so hard to get a good illumination through a small opening in a wall or partition.

Most shopkeepers are much impressed with the importance of the show window as an advertising agent, and are very loth to make any change in their windows for fear of decreasing the efficiency of their display. While there is no doubt that the display is of great importance, it is also true that in most of the stores of America the daylight must all come in through the front window, and unless one is permitted to discuss certain modifications in this window which affect the distribution of light his resources are very much limited.

Fortunately, stores in this country are built with high ceilings, so that, in most cases, there is room both for adequate display and for the admission of light. The show window is designed to attract the attention of people walking along the sidewalk. But, in order to walk without stumbling, one must have his eyes cast somewhat downward toward the street surface, and people have become so accustomed to this position of the eyes that they generally walk with eyes lowered even when the sidewalk is entirely smooth. These considerations suggest that a man's attention is hardly likely to be attracted by goods displayed more than eight or 10 feet above the level of the walk. We shall assume, then, that the upper four or five feet of the show window is of little value for display purposes and may be counted upon as the main avenue through which the daylight may be led into the salesroom.

(To be continued.)

Geo. Harmon was taken into custody in Keyser, W. Va., a short time ago, on a charge of trying to extort money from T. H. Davis, a jeweler at that place, by means of threatening letters.

The first meeting of the creditors of W. P. McFarland, Orange, Tex., who recently filed a petition in bankruptcy, was held at the County Court House at that place, recently. The hearing was adjourned without any definite action having been taken.

Storekeeping Department.

A Representative Retail Jewelry Store of Houston, Tex.

THE new store of L. Lechenger, Houston, Tex., is illustrated on this page. Mr. Lechenger has just moved into this store, which is located at 415 Main St., two doors from his former location, which was at the corner of Main St. and Prairie Ave. He has remodeled the entire place and it looks like a new building. Where before was a long, blank ceiling to greet the eye when looking about for decorations, there have been cut four "wells," with bevel edges, and in the bevel there are set small eight-candle-power incandescent globes, the hexagonal shape of the bevel frame being prettily shown by this illumination.

The chandeliers in the center of the store are of bronze copper, and there are four large crystallized round globes surrounding the brilliant incandescents inside. Lamps with high stands were placed at convenient places along the center of the store, the colors of each harmonizing nicely.

In furnishing this store Mr. Lechenger has selected San Domingo mahogany, and of that material every piece of wooden furniture in the house is made. The counter bases, the wall cases, the large center room cases are all fashioned with a nicety that is artistic in the extreme. On either side of the store there are six plate glass cases set on mahogany bases, and on each wall are long cases. On one side in the wall cases there is nothing but cut glass and etched glass. On the other side everything is sterling silverware. The plate glass coun-

ware, such as knives and forks, etc. In the front of the store is the large vault and on each side of the entrance are the work rooms.

Upstairs is shown the china ware, etc.

A \$75,000 Display.

THE display illustrated herewith, although not particularly timely just now, will interest many jewelers in view of its mag-



AN ELABORATE DISPLAY MADE OF PRECIOUS STONES WORTH \$75,000.

A feature of the store is the ladies' rest room, located in the rear of the store. This room is furnished in wicker, with

nificence and cleverness. It was shown in the jewelry department in the general store of Strawbridge & Clothier, Philadelphia, Pa. A typical Winter scene in the country is portrayed, and old Santa Claus is depicted in his sleigh driving a team of reindeer. The sleigh and reindeer are composed entirely of diamonds, except the eyes of the deer.

There are about 6,000 stones in the entire piece, 200 carats being used in the reindeer alone. The stone over the driver's head weighs eight carats. Diamonds of very large size also depict the lamps in the sleigh. The total value of the display is \$75,000.

Timely Advice to the Wise.

FOR persistent advertising nothing quite equals the newspaper. You can make a special effort along any line you like with folders, booklets and the like, backed up by the papers, too, but for reaching the largest number of people the oftenest and for the least money nothing equals the newspaper.

* * *

The man who is always waiting for the demand is never ready for it when it comes. Don't be afraid to buy goods for the busy seasons just because there isn't much doing now.

* * *

There's money in side lines if you get the kinds there's money in. Don't be too quick, though, to take up the proposition of the fellow who has something you can make a million on.



INTERIOR VIEW OF THE STORE OF L. LECHENGER, HOUSTON, TEX.

ter cases on one side contain only those things which are for women. On the other side the counter cases are devoted to articles for men, to toilet articles and flat

rocking chair, sofa, etc. There is a desk with stationery, a lavatory with clean linen handy, a full-length mirror, and other conveniences.

1 2 3 4 5 6 7 8 9 0 1 9 0 8 A B C D E F G H I J K

1
9
0
8

Alphabet and Figures
FOR CLASS RINGS, EMBLEMS, ETC..

1
9
0
8

HERPERS BROTHERS,
SETTING MANUFACTURERS,
Newark, N. J.,

1 9 0 8

1 9 0 8 A B C D E F G H ETC. 1 9 0 8

JANITSCHKE COMPANY, Inc.

33 UNION SQUARE, NEW YORK CITY

Manufacturers of
Patented

DIES

for the Silver and Metal
Trade

ARTISTIC CASTINGS OF EVERY DESCRIPTION
FOR THE SILVER AND JEWELRY TRADE

Iron Hubs and Bronze Forces, False Core Work and Undercut Castings with Elastic Patterns. Fine Plaster Castings by the *Janitschek Patent* Superior to the Asbestos Process

TELEPHONE, 400 STUYVESANT



HERMAN KOHLBUSCH, Sr.,

ESTABLISHED 1859.

Manufacturer of Fine Balances and Weights
for every purpose where accuracy is required.

Office and Salesroom, 194 BROADWAY, NEW YORK.

Send for Price List.

Tel. 370 Cortlandt.



New York Tortoise Shell Co.

13 EAST 30TH STREET,
Just East of Fifth Ave.

NEW YORK

Manufacturers of Fine

TORTOISE SHELL GOODS

Repairing given prompt attention.

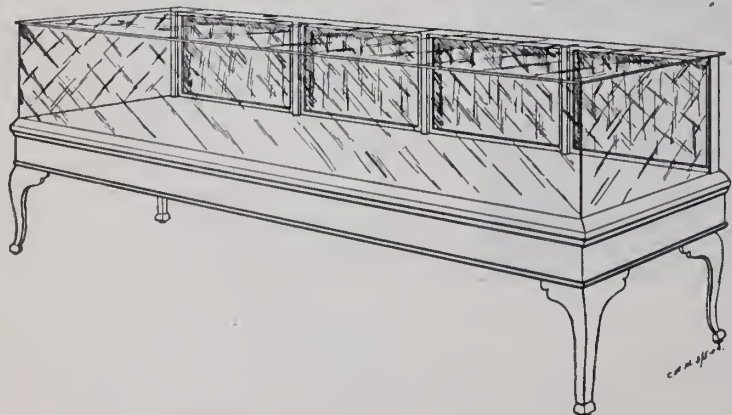

"FOR A QUARTER OF A CENTURY"

We have been manufacturers of

High-Grade Jewelry

Fixtures

Correspond with us before placing your orders

ALEXANDER H. REVELL & CO.

Rees, Dayton, Eastman and Hawthorne Streets,
Chicago, Ill.

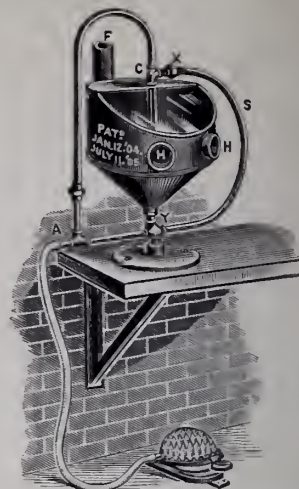

**A Small Compound
Sand Blast**

Price, \$20.00

Foot Bellows, \$6.00

WORKS AS EFFECTIVELY WITH
FOOT BELLOWS AS WITH
POWER BLOWER : : : :

MADE of Galvanized Sheet Iron, 10 inches diameter, Glass Top, Fittings of Brass and Iron, practically indestructible. Satisfaction guaranteed. Ask your Jobber for it, or write to us. Other Specialties: Zeuner's Best Jewelers' Saws; American Swiss Files, equal to the best imported; Gas Furnaces, for Melting, Annealing, etc., etc.; Positive Pressure Blowers.

E. P. REICHHHELM & CO.

JEWELERS' TOOLS, FILES AND SUPPLIES
24 JOHN STREET, NEW YORK

CRUCIBLES.

Jewelers' Supplies,
Etc.

Established 1850.

J. & H. BERGE,
95 John Street,
NEW YORK.

PRACTICAL COURSE IN ADJUSTING

Published Price, \$2.50.
Special Reduced Price, \$1.50, Postpaid.



WORKSHOP NOTES AND QUERIES

[Answers are also solicited from our readers to the questions published on this page.]

QUESTION No. 2107.—To Color Steel.—*Kindly tell me how to give steel a blue or black shade of color. I want to color an article which is to be sold for 10 or 20 cents.*
A. L. S.

ANSWER:—Sheet steel is usually shaded with japan, or the regular stovepipe enamel, which can be purchased from any store dealer. The price at which the article is to be sold would prohibit using any of the more expensive methods. We will give several formulas, some of which will probably answer your purpose. Before any of the formulas are used the steel must be free from grease. This is removed by immersing in hot potash. When clean, rinse off in water and dry in sawdust. A little rust will not harm for any of the enameling applications. *Stovepipe enamel*—This is painted on with a brush and left to dry. If dried in a warmed oven the enamel will be firmer and give a pretty black-blue luster.

Japanning.—There are two japons. One is applied by air drying and another is dried by means of heat. They can be purchased from various supply firms or japanners. The japan is brushed thin on the pieces and is then ready for drying. If an air-drying japan is used, place where there is no dust flying about; if a heat-drying japan, then place in a warm oven until thoroughly dried. If very many pieces are handled the japanning can be done in a tumbling barrel. The articles are placed in the tumbling barrel, a small quantity of the prepared japan is sprinkled over them, and the tumbling barrel is started. The japan is sprinkled over several times, or until a sufficient coat has been applied. The contents of the barrel are then taken out, separated and dried. The air drying must be done in a clean room and the heat drying in a warm oven.

Black lacquer.—There is also a jet-black lacquer sold by the platers' supply houses that will coat steel black by simply painting it on. Dry in a warm place. Two coats may be necessary in order to obtain a coating which will be thick enough.

Coppering and oxidizing.—A fine blue-black can be obtained by a method that is a little more expensive. The articles are first copper plated, then oxidized with sulphuret and lacquered. For this purpose a fairly good deposit of copper must be deposited, for light coppering would soon allow the steel to be seen through the black. The coppering should be done in a regular plating establishment, but the oxidizing can be done by almost anyone. The coppered pieces are immersed in a solution made by dissolving three ounces of liver of sulphur in one gallon of warm water. Add one ounce of ammonia, which will turn the piece black. Different shades of black may

be obtained by strengthening the solution with the liver of sulphur. When dry the pieces should be lacquered with black lacquer and dried in a warm place. *Blue-black on buttons.*—Button manufacturers color buttons by melting in a crucible two parts of binoxide of manganese and three parts of potassium nitrate. When well fused the steel is immersed and allowed to remain until it obtains a low red heat. It is then plunged into fish oil. Afterwards the oil is removed by means of caustic hot potash. Dry in sawdust. Many small articles are made of sheet steel where the coloring is put on the whole sheets and the pieces are cut out and shaped. The enamel or coloring is put on in thin layers, and stamping and shaping does not injure the enamel. This is really the cheapest method of making this class of articles. The prepared plates can be purchased.

QUESTION No. 2108.—To Oxidize Silver-Plated Articles.—*Will you kindly inform us how to oxidize silver-plated articles? We have recipes for the oxidation of sterling silver articles, but we would prefer to be absolutely sure about silver-plated goods.*
C. Y. R.

ANSWER:—Silver-plated articles are oxidized precisely in the same manner as sterling or fine silver. The only difficulty arises sometimes when the silver is worn through, or the plating may be too thin, so that the oxidizing fluid has not enough silver to work on and the underlying metal will not take the oxidizing. In this case the only remedy is a heavier deposit of silver.

Hard Genuine Babbitt.

AS made by the inventor, Isaac Babbitt, a genuine babbitt metal was a soft mixture and was really nothing but pewter, says the *Brass World*. The mixture which he used was composed of 50 parts of tin, five parts of antimony and one part of copper. This mixture, while suitable for many uses, utterly fails to meet the requirements of others. Even the so-called standard mixture of the present time, which consists of 96 parts of tin, eight parts of antimony, and four parts of copper, does not always serve the purpose.

A hard genuine babbitt, which will give the best service that it is possible to obtain, except in cases of severe pounding, is made of the following:

Tin	100 lbs.
Antimony	8 lbs.
Copper	8 lbs.

This mixture will stand hammering into the recesses of the box and will wear without cracking.

The Sphygmometer.

THE sphygmometer (patented in France and foreign countries), is a new watch, especially adapted for the use of physicians. It gives, rapidly and without calculation, the number of beats of the pulse in a minute.

When the sphygmometer stands at zero, that is to say, when the long second hand stands at 12, it is sufficient for the purpose of making an observation to set the large hand in motion by pressing on the push button, placed above the crown of the stem-winding stem at the moment, when the counting of the pulsations begin.

Arrived at the 20th pulsation the motion of the hand is stopped by another pressure

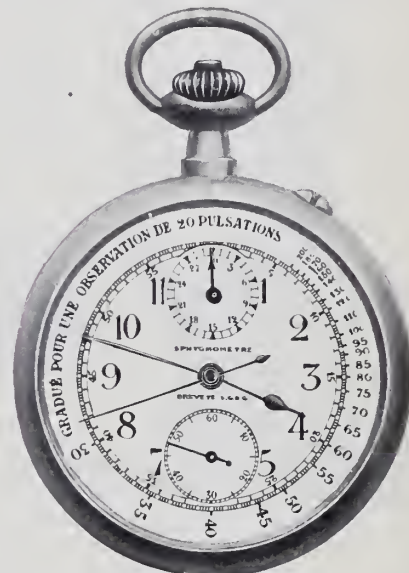

WATCH FOR COUNTING PULSE BEATS.

on the push button. All that remains to be done then is to read on the edge of the dial the number indicated by the hand and the number of the pulsations per minute. This observation completed, it is sufficient to bring the hand back to zero to press the button for the third time. During the entire operation it is useless to follow the progress of the watch with the eyes, the hand obeying the pressure of the finger on setting it in motion again or stopping it at the desired instant.

The instrument is also a chronographic counter facilitating the making of observations, which are automatically recorded in minutes, seconds and fifths of a second. The small dial placed below the 12 records minutes from 0 to 30. The large hand records seconds and fifths of a second. The sphygmometer is substantially and attractively made, easily repaired and non-magnetic. It is a real timepiece of precision, having Breguet balance spring and compensation balance, a chronograph and an instrument to count beats of the pulse and of the heart.

W. E. Newson, Lonoke, Ark., has closed his store and will move to Beeville, Tex., April 5.

David S. C. Brimer, Page, N. Dak., closed out, recently, and has gone to Hope, N. Dak., where he will engage in business with H. H. Fulmer.

C. DORFLINGER & SONS

36 MURRAY STREET

NEW YORK

Hand-Made Blanks only.
Cut, engraved and etched
glass. Light, medium
and heavy stemware,
tumblers, etc.

The Pairpoint Corporation

NEW BEDFORD, MASS.

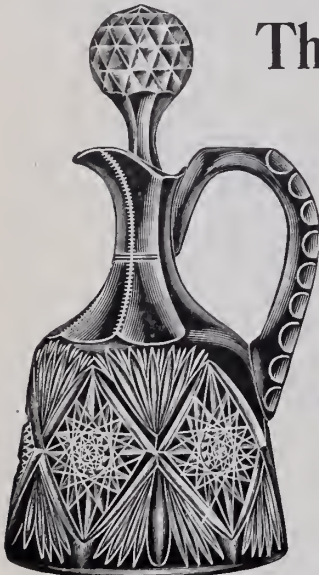

SUPERIOR
SILVER PLATED
WARE

RICH
CUT GLASS
WARE

ELECTROLIERS
GAS PORTABLES, ETC.



No. 4935.—Smoking Set.

BRANCHES

No. 692.
Whiskey Jug.
"Uncatena."

38 Murray Street - - - - NEW YORK CITY
717 Market Street - SAN FRANCISCO, CAL.
485 St. Catherine Street - MONTREAL, P. Q.



LA VIGNE TEASPOON



LA VIGNE TABLESPOON



LA VIGNE MED. FORK

The latest and newest in ROGERS FLATWARE

HAVE YOU SEEN IT?

Bright or French Gray. Sample dozen on approval. Write for prices and terms.

JOSEPH IRONS, 35 Maiden Lane

Irving Cut Glass Co. Inc.

Manufacturers of

Artistic Cut Glass

HONESDALE, PA.

F. W. REICHENBACHER

New York Representative

No. 25 WEST BROADWAY, Room 43



"Wild Rose," No. 122—14-inch
Ice Cream Tray

THE WASHBURN

SECURITY

MAGIC NUT

Automatic Holder
for all sizes of scarf-
pin wire. Guaranteed.

for ear studs, scarf pins
etc.



EAR WIRES
for unpierced ears.



SAFETY CATCH
For Brooches, etc.
Can be applied to an
order where pin tongue
are used.



Open. Closed. Open. Closed.

Descriptive Circular on Application.
Pearl Drilling and Adjusting a specialty.
Special Order Work and Repairing.

C. IRVING WASHBURN, 12-16 John St., N. Y.

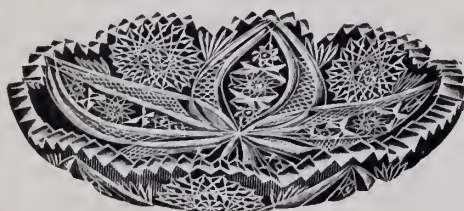

7 in. Saucer, Pansy No. 205

KELLY & STEINMAN, Inc.

Manufacturers of RICH CUT GLASS

HONESDALE, PA.

Artistic Designs, Graceful
Shapes, Excellent Workman-
ship and Unsurpassed Finish
together with Moderate
Prices explain the Popu-
larity of our line.

SEND FOR CATALOG

Established 1879

Manufacturer of

LOUIS W. HRABA

Fine Leather Goods

29 East 19th St., New York

Exclusively for the Jewelry Trade

JACOT MUSIC BOX CO.

MIRA MUSIC BOXES
AND MIRAPHONES

39 UNION SQUARE - NEW YORK.

THE CONNOISSEUR

Devoted to Art Pottery, China, Marbles, Bronzes, Cut and Decorated Glass Ware, Bric-à-Brac, Lamps, Art Metal Wares, Fancy Goods and Kindred Lines.



Old Denby Salt-Glazed Stoneware.

THE actual date of the introduction of salt-glazed stoneware into England is still a matter of uncertainty. In the 16th century large quantities of stoneware were imported from the Continent, principally from Cologne; but toward the end of the century some Dutch potters commenced the manufacture of stoneware in London, says a staff contributor to the *London Pottery Gazette*. Somewhere about 1688 to 1692 the famous brothers Elers settled near Burslem and produced hard stoneware of one quality on the German method. There is no doubt that they commenced that improvement in pottery manufacture that has continued without interruption, and which has placed English earthenware in the high position it now occupies among the pottery productions of the world. But I must limit myself to the production of stoneware, and not be tempted into the other and perhaps more fascinating branches of English pottery.

Very little is known about the first manufacture of stoneware at Denby. It was made at Nottingham, Chesterfield and Brampton as early as the beginning of the 18th century. Glass pots and crucibles were made at Nottingham from an earlier period, and it is assumed that German or French potters settling in the district applied their knowledge of salt glazing in the manufacture of the local stoneware. Seeking information about the industry at Denby I naturally turned to Wm. Burton's interesting work on "English Earthenware and Stoneware." I was disappointed. When I found that he had nothing to say about it, I at once concluded that very little was known. Mr. Burton says: "The industry, once started at Nottingham, might readily spread as far as Brampton and Chesterfield." And he adds: "Though stoneware is no longer made in Nottingham itself, the industry still flourishes * * * at Chesterfield, Brampton and Denby."

Salt-glazed stoneware was admittedly introduced about 1680 for common descriptions of hard stoneware, especially for drain pipes and vessels for holding corrosive acids. It was found that the high temperature at which salt glaze was fired rendered it most suitable for such purposes. The legend of the discovery of salt glaze is in appropriate companion to that of the discovery of glass and I imagine they are about equally true—or false, rather. It is said that some Phœnician merchants placed their cooking-pots on some blocks they found on the shore. These proved to be blocks of natron (sub-carbonate of soda) and the fusion of the alkali and the sand

produced glass. Shaw, in his "History of the Staffordshire Potteries," page 108, says: "At Stanley Farm, near Burslem, a short distance from the small pottery of Mr. Palmer, a servant was boiling in an earthen vessel a strong lixivium of common salt, to be used some way in curing pork; but during her temporary absence the liquor effervesced and some ran over the sides of the vessel, quickly causing them to become red hot. The muriatic acid decomposed the surface, and, when cold, the sides were partially glazed. Mr. Palmer (the potter) availed himself of the hint thus obtained."

Be this as it may, briefly, in practice, salt glaze is applied by throwing common salt (chloride of sodium) into the hot kiln when the process of firing is nearly complete. The salt is volatilized and decomposed, the soda combines with the free silica in the clay and a coating of hard silicate of soda is formed. Those who are interested in this subject will find it very ably and interestingly dealt with in Mr. Burton's work. The early potters, and subsequently Bourne, of Denby, applied salt glaze in the manufacture of sanitary ware and domestic ware—jugs, pots, stands, foot-warmers and cooking vessels, ginger beer bottles, soda water bottles, etc. But the most extensive use of salt glaze in Staffordshire at that time was in glazing figures. At the commencement of their career Bourne's also made a number of figures, and they seem to have worked on the same lines as Dwight, Wood and others in making commemorative figures and groups. These, however, were made in small numbers, as compared with useful articles, and they are consequently now very rarely met with.

Although Bourne & Son and some other manufacturers of salt-glazed stoneware make useful articles almost exclusively, and do not now make figures, the term "salt-glazed" ware is generally understood to be fine stoneware, colored drab or white, glazed with salt, showing the fire pitting on the surface like that on the skin of an orange or on fine leather. This is a characteristic of what is now meant by "Staffordshire" ware, and also of similar ware which was made in Liverpool, Lambeth, Denby, Chesterfield and some other places in the late 18th and early 19th centuries. These salt-glazed figures are mostly of small size, and those at Denby took the form of spirit bottles, bearing the heads and busts of various Reform leaders and prominent persons of that period.

S. M. Grossman, Toronto, Ont., has obtained a new lease of his premises at 177 Yonge St., in which he will make extensive alterations and improvements.

An Interesting Lecture on Enamels.

J. ARNOLD FLEMING, F.C.S., recently gave in the Glasgow School of Art an interesting lecture on "Enamels, Their Construction, Defects and Qualities." He introduced this fascinating subject by giving an account of the historic enamels, "The Sword of Charlemagne" at Vienna in cloisonné enamel, the *Pala d'oro* or altar front at Venice, the shrine of the Three Kings at Cologne Cathedral, and lastly that most interesting jewel at Oxford, supposed to have belonged to King Alfred. *De plique à jour*, imitating transparent stones, Bas-setaille work, and the more general champlevé styles of enameling were also briefly dealt with.

Mr. Fleming then demonstrated the inseparable connection of the chemical composition of an enamel with the physical combination that in mixing an enamel the artist has always to bear in mind the effects of a temperature more or less high. Some of the early enamels previous to the 13th century especially, show efflorescence, showing that excessive dampness had attacked the overflux colors. Carbonic acid gas and sulphuretted hydrogen were also enemies, and these often went by the name of an "odor of sanctity" in many old damp and badly ventilated churches.

The wonderful powers of fluxes that cause the molecules of a substance to change from the solid to liquid and from the liquid to the solid state of aggregation were next dealt with. It is well known a flux can only absorb its known quantity of coloring base; that if at a greater temperature it absorbs more than that given amount it will reject that excess on cooling. The laying of the colors on the metal or pottery was, if anything, the most interesting point of the lecture.

It was duly impressed on the students not to lay the colors on too thickly with a view to giving vigor of tone to the painting, but to obtain this by the simple colors alone and without thickness. But if depth of color must be obtained it must be solely done by retouches, followed by as many firings, success depending entirely on details of manipulation, and labor that seems useless, such as grinding and mixing enamels that already appear fine enough, will abundantly be repaid by the superior quality of resulting colors.—*London Pottery Gazette*.

Trask & Plain, Aurora, Ill., contemplate closing out their stock in Quincy, about May 1. The establishment at Quincy is one of four which the concern has been operating in conjunction with its main store in Aurora.



Autumn Harvest Scenes

Rich Brown Glaze

The latest production of the *Royal Doulton* factories. Exquisitely enameled in rich colors.

Sole Agent

W.S. Pitcairn

44 Murray Street
New York

Write for Booklet, "Quaint Bits of Royal Doulton"

"AUTUMN"
SERIES No. D2777

The St. James

Cor. Walnut and 13th Sts., Phila., Pa.

THE IDEAL HOTEL OF
THE QUAKER CITY

A spacious fire and burglar proof safe has been provided for the convenience of the trade. Palatial rooms with bath \$2.50 per day and up. Rooms without bath, (running water) \$2.00 and up.

EUGENE G. MILLER, Mgr.

CROUCH & FITZGERALD



Jewelry Trunks and Cases

177 Broadway,
Bet. Cortlandt
and Dey Sts.
688 Broadway,
723 6th Ave.,
New York.

WANTED WATCHMAKERS everywhere to know about

URICH Perfect Fitting CASE SCREW WASHER

Will hold movements securely in their case, even when shoulder is worn away. Fits perfectly under head of screw, and is almost invisible. Prices:

Single Dozen, - - - 15c
4 Doz. Package, assorted, - - 50c
Gross, - - - \$1.50 Pat. app. for



For sale at all Jobbing and Material Houses.

S. URICH, P. O. Box 1942, New York City

PATENTS

obtained on inventions and designs. Trade marks, prints and labels registered.

R. W. BISHOP,
ATTORNEY-AT-LAW,

908 C Street N.W., Washington, D.C



TRADE **R** MARK

ESTABLISHED
1850

HAND BAGS

We have a very extensive collection in all desirable leathers

C. F. RUMPP & SONS
FINE LEATHER WARE

Fifth and Cherry Streets
PHILADELPHIA

New York Salesrooms, 683 and 685 Broadway

Correspondence Solicited

UNIQUE ART GLASS AND METAL CO.

46 PARK PLACE, NEW YORK

Makers of High Grade

Art Glass Dining Room Fixtures

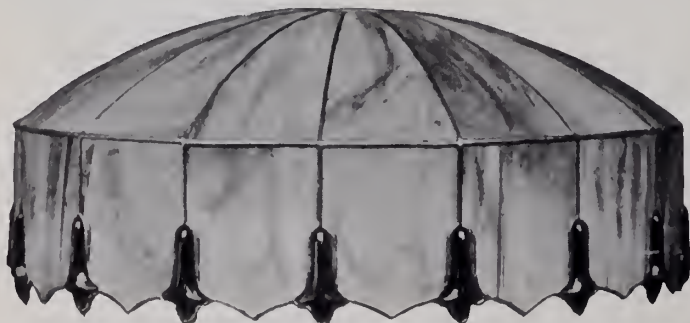

3030—16 in. Diameter

LAMP SHADES, ELECTRIC
SHADES AND PORTABLES

CALL IN AND SEE OUR BEAUTIFUL LINE
OF PRODUCTS AT POPULAR PRICES :: ::

Also an elegant line of Rich Crystal Cut
Glass at Factory Prices

The Status of Foreign Corporations Doing Business in Illinois.

DURING one of the lulls in the recent examination of Jos. Brown & Co., bankrupts, at Chicago, a discussion arose as to the rights of foreign corporations in civil suits. It was conceded that in bankruptcy matters, as the Federal Court had jurisdiction, it was an interstate matter and not subject to the laws of Illinois; but where no question of interstate commerce arose, and where a foreign corporation had either a representative or an office in Chicago, it was claimed that this corporation had legally no right to do business in Illinois unless it took out a charter to do business in the State of Illinois. As the questions involved have given rise to considerable discussion, and for the purpose of placing before our readers the status of the law relative to foreign corporations doing business in Illinois, we obtained the following information:

In 1905 the legislature of the State of Illinois passed a revised act relating to foreign corporations, and provided that no foreign corporation would be allowed to transact business in that State until it had complied with certain prerequisites. It provides that a foreign corporation shall make a written application signed and sworn to by the president and secretary, stating what business the corporation proposes to pursue under its charter, the amount of its capital stock, the proportion of its business intended to be carried on in the State of Illinois, the amount paid in on its capital stock, what property and assets, and an estimate of the value thereof, will be employed in the business of the corporation in the State of Illinois, and further providing among other things that some person must be nominated upon whom service of process may be had in all suits commenced in that State. The fees charged by the State are the same as for local corporations, namely: \$30 for corporations whose capital stock (being the amount of capital, in the case of foreign corporations, employed in the State, and not its capitalization in its home State) does not exceed \$2,500, and \$50 where the capital stock does not exceed \$5,000, and \$1 additional for every thousand dollars in excess of \$5,000.

The statute further provides that in the event a foreign corporation fails to comply with the act that it cannot maintain any suit of any kind in the courts of the State. The act also provides for a penalty of \$1,000 and not more than \$10,000, which may be assessed against any corporation doing business in the State in contravention of the act.

The courts of Illinois have gone to considerable length in construing the law as applicable to what may be considered doing business within the State, and the construction is of especial value to our clientele by reason of the fact that many of our eastern manufacturers and wholesalers regularly consign goods to dealers in Illinois.

Attention has been called to the case of the Union Cloak & Suit Co. vs. Edward Carpenter, et al., reported in 102, Illinois Appellate Court Reports. The facts in the case were as follows: The Union Cloak & Suit Co. was a corporation of the State of

New Jersey, and had not qualified in the State of Illinois. On two different dates in December, 1900, the cloak company shipped certain goods on consignment to a firm doing business in South Chicago, Ill. Returns at the invoice prices for the goods so consigned were to be made every Saturday night, and goods not sold were to be returned to the cloak company. The goods could be sold at any price the consignees saw fit to ask. The goods, while in the possession of the consignees, were attached and the cloak company sought to recover the property in an action of replevin. The suit of the cloak company was dismissed on the ground that the company was a foreign corporation not qualified to do business in the State, and, therefore, under the law, without right to maintain any suit of any character in that State. The Appellate Court held that the consignees were the agents to sell the goods of the cloak company at retail, and by reason thereof it was engaged in doing business in the State of Illinois; that the dismissal of the suit of the cloak company by the County Court of Cook County was proper, and affirmed the judgment of the lower court.

The Supreme Court of Illinois has held that, even though the foreign corporation subsequently qualifies itself to transact business in that State, such action will not be held to relate back to the time of contracts entered into before such qualification was had, and that a defense to any contract or to any suit where recovery is sought to be had for goods sold and delivered could not be maintained, and that the compliance with the law of the State by such foreign corporation only validated transactions had after the date of such qualification to do business.

We are advised that all foreign corporations which maintain an office in the city of Chicago or elsewhere in the State of Illinois, and particularly where there are resident agents, and where merchandise is carried either in stock or for inspection, would, in view of the decisions of the State of Illinois, be unable to successfully maintain a suit against any one indebted to them.

In view of the foregoing, it has been suggested to those corporations now transacting business in the State of Illinois without having complied with the laws of this State, that an application be at once filed with the Secretary of the State for leave to do business, and that they qualify immediately. The expense of so doing is nominal and would undoubtedly be saved many times over in the event it became necessary for such foreign corporation to institute suits in that jurisdiction.

We are indebted for the above information to Israel Shrimski, an attorney, of the *Tribune* building, Chicago, who will be glad to furnish further information on the subject to all who are interested.

John Lopez, 71 years old, and for several years engaged in the optical business at the corner of 701 Marion St., St. Louis, Mo., died March 18 after drinking a quantity of carbolic acid. Lopez was despondent on account of ill-health and business reverses. He is survived by a son, Jacob Lopez, of East St. Louis, Ill., and one daughter, Mrs. Chas. Wenterer.

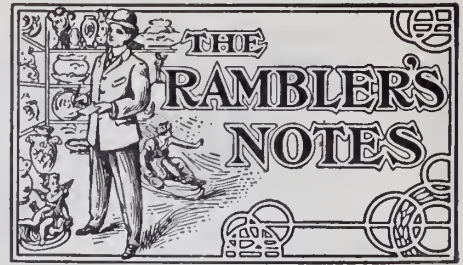

FRENCH CHINA
PLATES

THE display of attractive china at the New York salesrooms of Haviland & Co., 45 Barclay St., affords an almost unlimited opportunity for jewelers interested in this line to find something of interest. The exhibit of service plates with narrow acid gold borders and others with golden circlets about the rim and shoulder was never larger; bands of different widths are shown on several plates. Gold and wreath patterns daintily entwined about the borders of the plates, leaving the rest of the plates free of decoration, are included in the display. Plates with heavy blue, red and green bands within narrow gold bands are seen together with a variety of other patterns in pleasing effects.

NOVELTIES IN ROYAL
DOULTON.

AT the warerooms of W. S. Pitcairn, 44 Murray St., New York, are now to be seen the latest products of the Royal Doulton china ware depicting nursery rhymes. The illustrations are in rich enameled colors and make most attractive offerings. Rhymes such as "The Mad Hatter" and others of like character are included in the subjects selected to be illustrated. At the same salesrooms is a most attractive line of fine service plates in a variety of designs, among which the latest flower and leaf patterns predominate. Plates with narrow encrusted gold borders and others with wide borders are also included in the exhibit.

A FINE DISPLAY
OF CLOCKS.

AT their salesrooms, 37 Maiden Lane, New York, Sussfeld, Lorsch & Co. have on exhibition a most attractive line of clocks, among which is a Westminster chime hall clock worthy of special mention. It has a mahogany case 89 inches in height and 21 inches wide. It has a five-chime movement striking on nickel-plated hollow tubes. The dial is highly ornamented in gilt, with silver finished rim, and is 12 inches in diameter. Other offerings shown by the same firm include mantel chime clocks, novelty clock and attractive cuckoo clocks. Jewelers visiting New York will find much of interest in this display.

The following officers of the Williamsport, Pa., Board of Trade have been elected: President, Hon. S. M. Williams; first vice-president, C. L. Munson; second vice-president, James L. Kline; treasurer, Hon. James Mansel; recording secretary, Wm. C. Robinson.

A SHEAR

that will cut any kind of design to perfection. Better have a pair—they are mighty useful.

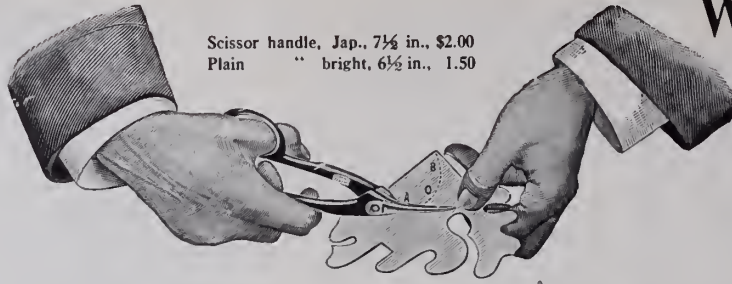

Scissor handle, Jap., 7¼ in., \$2.00
Plain " bright, 6½ in., 1.50

William Dixon,

Incorporated

39 John St., New York

Formerly

F. W. GESSWEIN COMPANY

LEES & SANDERS,

CHEAP AND QUICK TRANSIT IS BRINGING
TRADE FROM ALL OVER THE WORLD

SWEEP SMELTERS, BIRMINGHAM, ENG.

WM. F. RENZIEHAUSEN CO.

43-47 Oliver Street, NEWARK, N. J.

Gold and Silver Refiners

PROMPT RETURNS MADE FOR ANY MATERIAL CONTAINING PRECIOUS METALS
DEALERS IN GOLD AND SILVER, AND ROLLERS OF STERLING SILVER

Gold and Silver Anodes a Specialty

Phone 3759-R.



WE BUY

Old Gold and Silver Filings, Polishings, Sweeps, Hand Washings, etc. We will make accurate valuations and hold consignment subject to your acceptance. If valuation is not satisfactory, we reship to you at our expense.

WE PAY FOR OLD GOLD:

22 K. 88c. per dwt.	12 K. 48c. per dwt.
20 K. 80c. " "	10 K. 40c. " "
18 K. 72c. " "	8 K. 32c. " "
16 K. 64c. " "	6 K. 24c. " "
14 K. 56c. " "	4 K. 16c. " "

MARKET RATES FOR SILVER AND PLATINUM

Try us and you will Appreciate our Squareness, Promptness and Accuracy.

T. B. HAGSTOZ, Ltd., Main Office, 709 Sansom St., Philadelphia, Pa.
SMELTERS, ASSAYERS, REFINERS.

WE SELL

Gold, Silver and Platinum, various qualities, rolled flat or drawn to wire of any gage.

PRICES OF ALLOYED GOLD:

8 K. 42c. per dwt.	14 K. 66c. per dwt.
10 K. 50c. " "	16 K. 74c. " "
12 K. 58c. " "	18 K. 82c. " "

Gold and Silver Solder, either from formulas furnished, or our own. "T. B. H." Alloy, 25c. per oz. Guinea Gold, 75c. per lb. Shot Copper, 40c. per lb. We will send tables for alloying without charge. They save figuring.

ESTABLISHED 1886

CEO. M. BAKER

TELEPHONE UNION 1493-R

Gold and Silver Refiner and Sweep Smelter

Office, 91 Page St. } PROVIDENCE, R. I.
Works, 77-85 Page St. }

Our processes are strictly up to date and facilities most complete for doing all kinds of refining.
Specialties: Prompt and good returns.

CASTINGS

Gold, Silver, Bronze, Brass, German Silver, Copper and Iron.
L.D. TEL. 2072 L. Supply Jewelers, Silversmiths, Die-makers, Mould-makers, etc. Bronze Forces, Hard Bronze and Iron Shells for Die-cutting Machines. Cast Iron Hub for sinking in Steel Dies. Chandeller, Undercut Work, Statuary.

AUGUST GRIFFOUL 313 HALSEY STREET NEWARK, N.J.



THE **R. & L.** OIL

The R. & L. Oil is made especially for those expert watch and clock makers who must have the best and most reliable oil on the market. It does not gum or change, and possesses all the requisites needed for the most delicate mechanisms. Send 25c. to your jobber, asking for R. & L. Oil.

Wholesale Selling Agents

- M. SICKLES & SONS . . . Philadelphia
- SWARTCHILD & CO. Chicago
- NORDMAN BROTHERS CO., . . . San Francisco
- D. C. PERCIVAL & CO. Boston
- CHAS. MAY & SON Boston
- DANIEL PRATT'S SON Boston
- 53 Franklin Street, Boston
- SUSSFELD, LORSCH & CO., . . . New York City
- H. S. MEISKEY CO. Lancaster Pa.

RANLETT & LOWELL CO.

SOLE MANUFACTURERS
Jewelers' Building BOSTON, MASS.

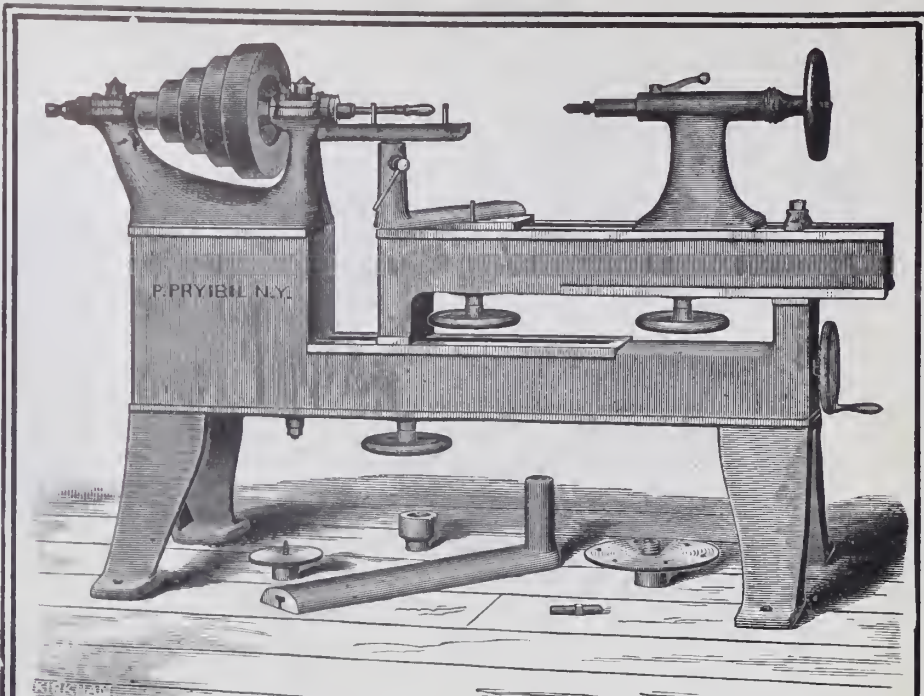

Above Cut Shows Our
EXTENSION SPINNING LATHE.

Swing of lathe 22 inches when closed, 44 inches when extended.

Substantially built for heavy work.

Write for
Catalogue

P. PRYIBIL, 512-524 W. 41st St., New York.

Importer and Manufacturer of
WATCH MATERIALS, TOOLS, JEWELERS'
SUPPLIES AND OPTICAL GOODS



Bargains
in
**Engraving
Blocks**

Prices on
Application.

Fine Gold, Silver and Platinum always on hand.
Highest Prices paid for Old Gold and Silver.

A. ZAREMBOWITZ

250 East Houston Street NEW YORK

Learn Watchmaking

Refined, profitable labor. Competent men always in demand. We teach it thoroughly in as many months as it formerly took years. Does away with tedious apprenticeship. Money earned while studying. Positions secured. Easy terms. Send for catalogue. Address

St. Louis Watchmaking School, St. Louis, Mo.

JOHN AUSTIN & SON

Assayers, Refiners and Smelters

74 & 76 Clifford Street

PROVIDENCE, R. I.

We Do Our Own Smelting.



L. LELONG & BRO.

Gold and Silver Refiners, Assayers and Sweep Smelters

S. W. Cor. Halsey and Marshall Sts., NEWARK, N. J.

Prompt attention given to Gold and Silver Bullion.

SMELTING FOR THE TRADE.

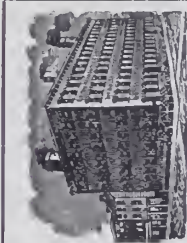

UNITED STATES SMELTING AND REFINING WORKS

L. & M. WOLLSTEIN

16 JOHN STREET, NEW YORK

SWEEP SMELTERS AND ASSAYERS

Dealers in Gold and Silver Assay Office Bars. HIGHEST and MOST PROMPT RETURNS made for Sweeps and all kinds of Waste containing precious Metals.

HIGHEST PRICES PAID FOR OLD GOLD AND SILVER

Manufacturers of STERLING SILVER.

Importers of PLATINUM.

Ore and Bullion Assays a Specialty.

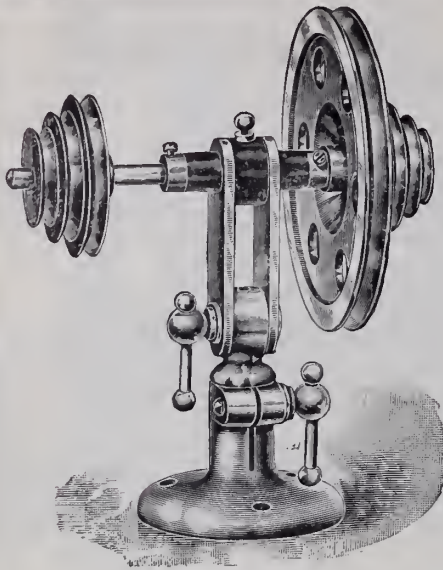

A New Patent Speed Wheel Countershaft

made by G. Boley, all polished and nickel plated, being made with hard bronze bearings which insure perfectly true running, with attachment to hold all wheels for grinding or polishing.



Robbins' Upright Roller Remover

With Improved Revolving Disk and Plunger

Flat bottom, which sets firmly on the bench. You cannot break pivots with this tool, as it is very easily adjusted for any size from jewel series to the largest size. Single or double roller. Nickel-plated. Price, \$2.25.

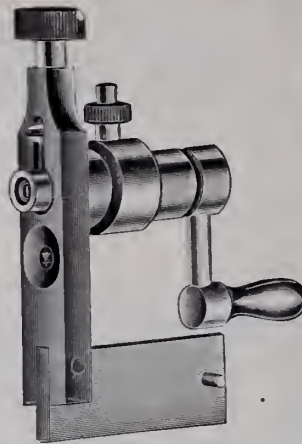

Robbins' Latest Improved Patent Mainspring Winder

Does away with changing of barrels, which alone is a time saver.

Nickel plated, price \$2.00. Directions with each tool.

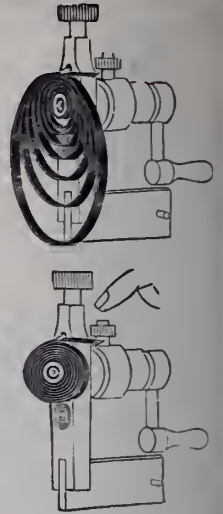

ASK YOUR
JOBBER
FOR SAME

SOLE AGENTS:

77 John Street,
New York City

HENRY ZIMMERN & CO., Inc.

Exclusive Wholesale
Distributors for
U. S. and Canada.

NOVELTIES

FANS

For the Jewelry Trade

A complete stock of unusual and exclusive designs

Louis Steiner

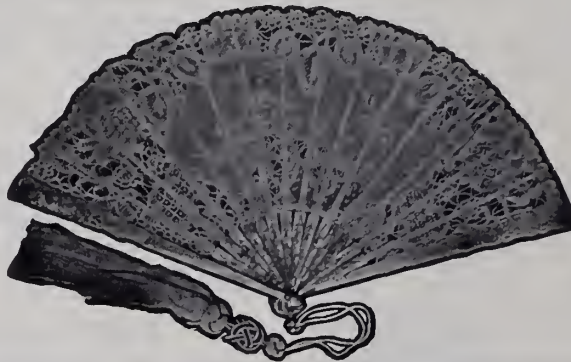

NOVELTIES

FANS

of Every Description

An assortment of Fans that is unequalled in this country

520 and 522 BROADWAY
NEW YORK



LEMAIRE OPERA GLASSES

LEMAIRE FIELD GLASSES

Best in the World. Used in the Army and Navy.

SUSSFELD, LORSCH & CO., Importers

37 MAIDEN LANE, NEW YORK

MARQUE DE FABRIQUE



All Genuine Glasses
Bear This Mark
Large Variety in All
the Latest Styles

PLATINUM AMERICAN PLATINUM WORKS
NEW YORK OFFICE
41 Cortlandt Street
NEWARK, N. J.

THE

JEWELERS' CIRCULAR

WITH WHICH ARE CONSOLIDATED

THE HOROLOGICAL REVIEW,

THE JEWELERS' WEEKLY,

THE JEWELERS REVIEW

Copyright 1908 by
The Jewelers' Circular
Publishing Company.

11 John St., Corner Broadway, New York.

Entered as second-class matter at the New York, N. Y., Post Office.

40th Year

WEDNESDAY, APRIL 15, 1908.

Vol. LVI., No. 11.

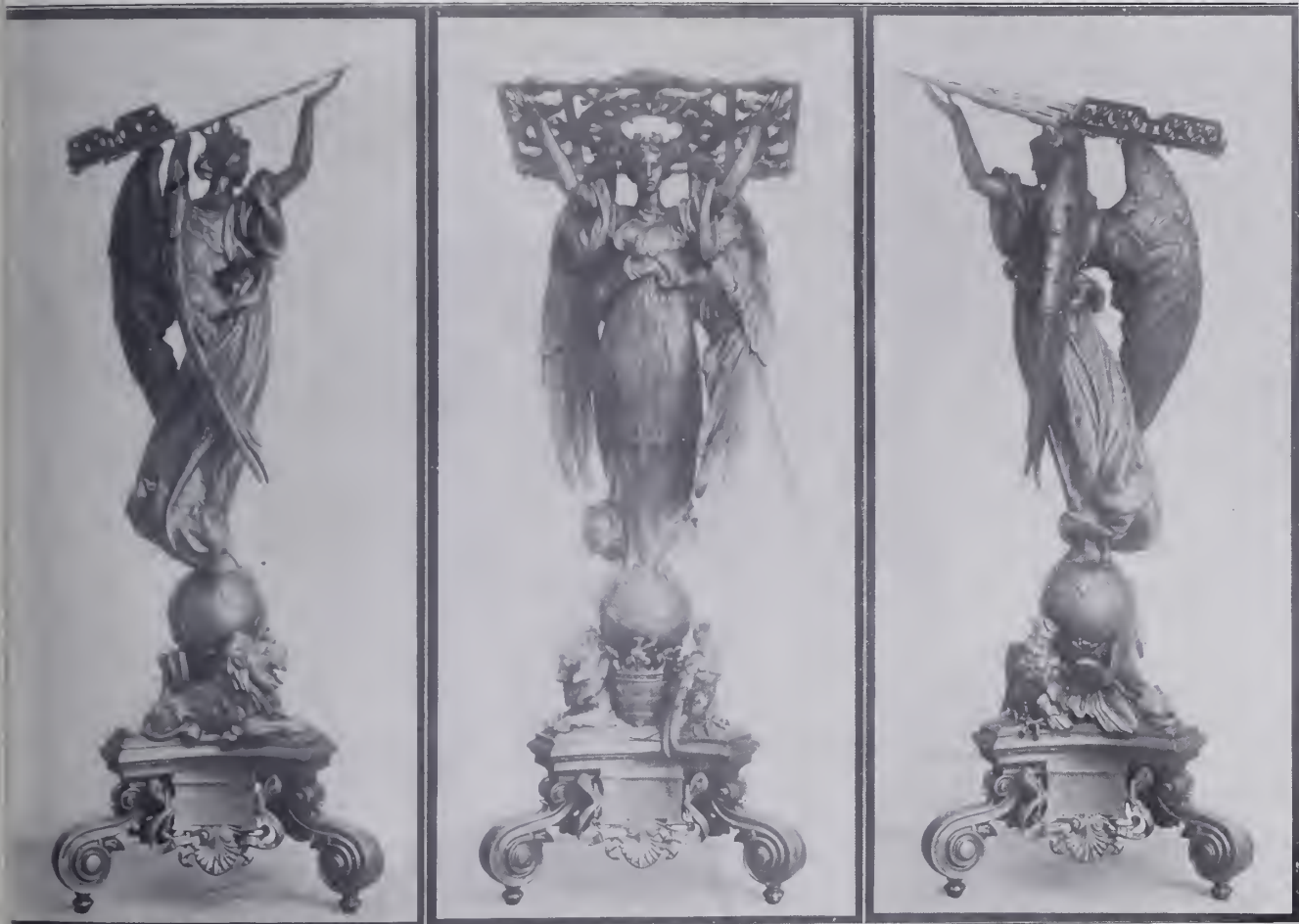

Bronze Lectern Presented by President Roosevelt to Bruton Parish Church, Williamsburg, Va.,
to Hold the Bible Presented by King Edward VII.

(See Text on Page 39.)

ALVIN SILVER



BRIDES BOUQUET.

Immediately after Easter there will be an unusual number of weddings.

Silver is always thought of when wedding presents are in demand.

This year there will be many who feel they cannot afford STERLING SILVER flat ware, and if they know of the Alvin PLATED Ware they can give flat ware that will look like Sterling and wear a lifetime.

"The Lily" and "The Brides Bouquet" patterns are of the best silver plated ware made, and in patterns heretofore associated only with Sterling Silver ware.



LILY.

ALVIN MFG. CO

SILVERSMITHS

NEW YORK

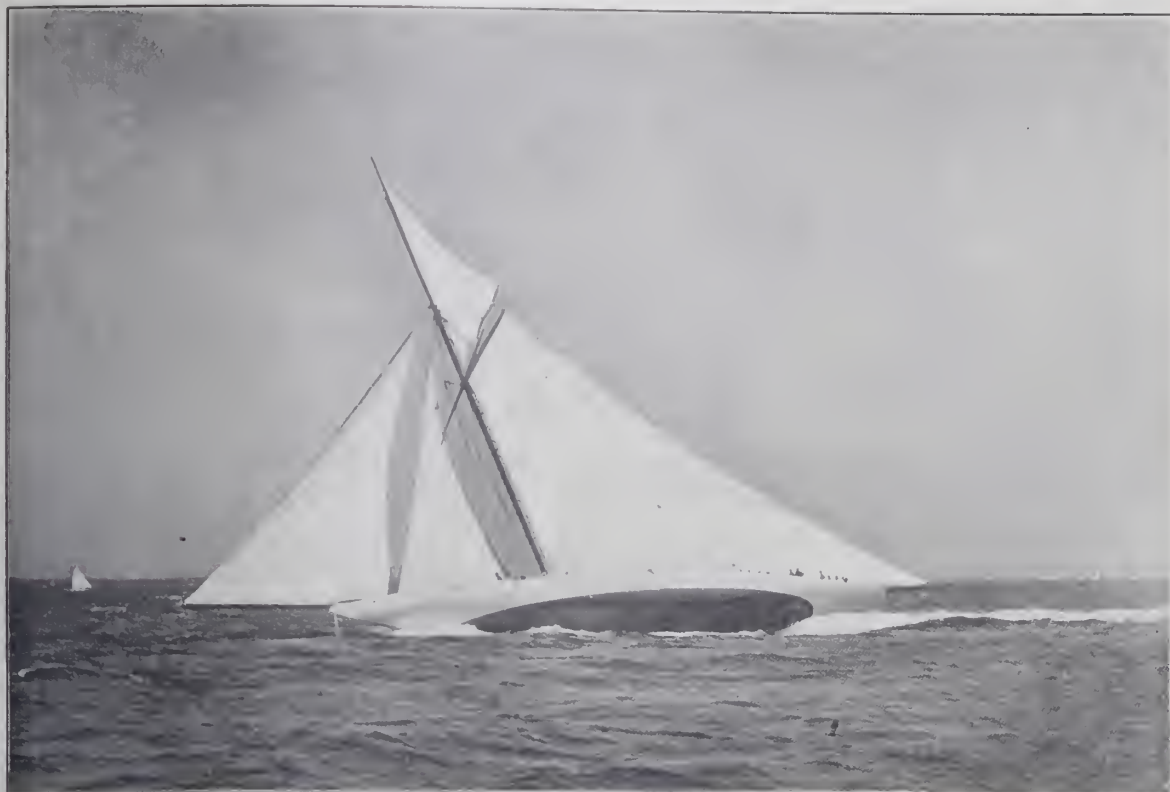

Are you sailing in the right direction by having a full line of

Fahys Bristol Cases

in stock?

So many styles and designs to choose from that every taste must be suited.

There is nothing better made in a 25-Year Case. Why not buy the best?

They win out because of the large "sales."

All made with our patent one-piece pendant, eliminating all solder. This patent is controlled by us exclusively.

JOSEPH FAHYS & CO.

New York

Boston

Chicago

San Francisco

A GENERAL FAVORITE



A general favorite is one whom everybody likes.

Our diamonds are general favorites with those who have seen them.

First, because of the perfection of their cutting, assuring greatest brilliancy, and,

Second, because, we being cutters, there are not two or three profits tacked on to the actual worth of the stones.

J. R. WOOD & SONS

DIAMOND CUTTERS

Importers of Emeralds, Rubies and Sapphires

2 Maiden Lane, Corner of 170 Broadway . . . NEW YORK

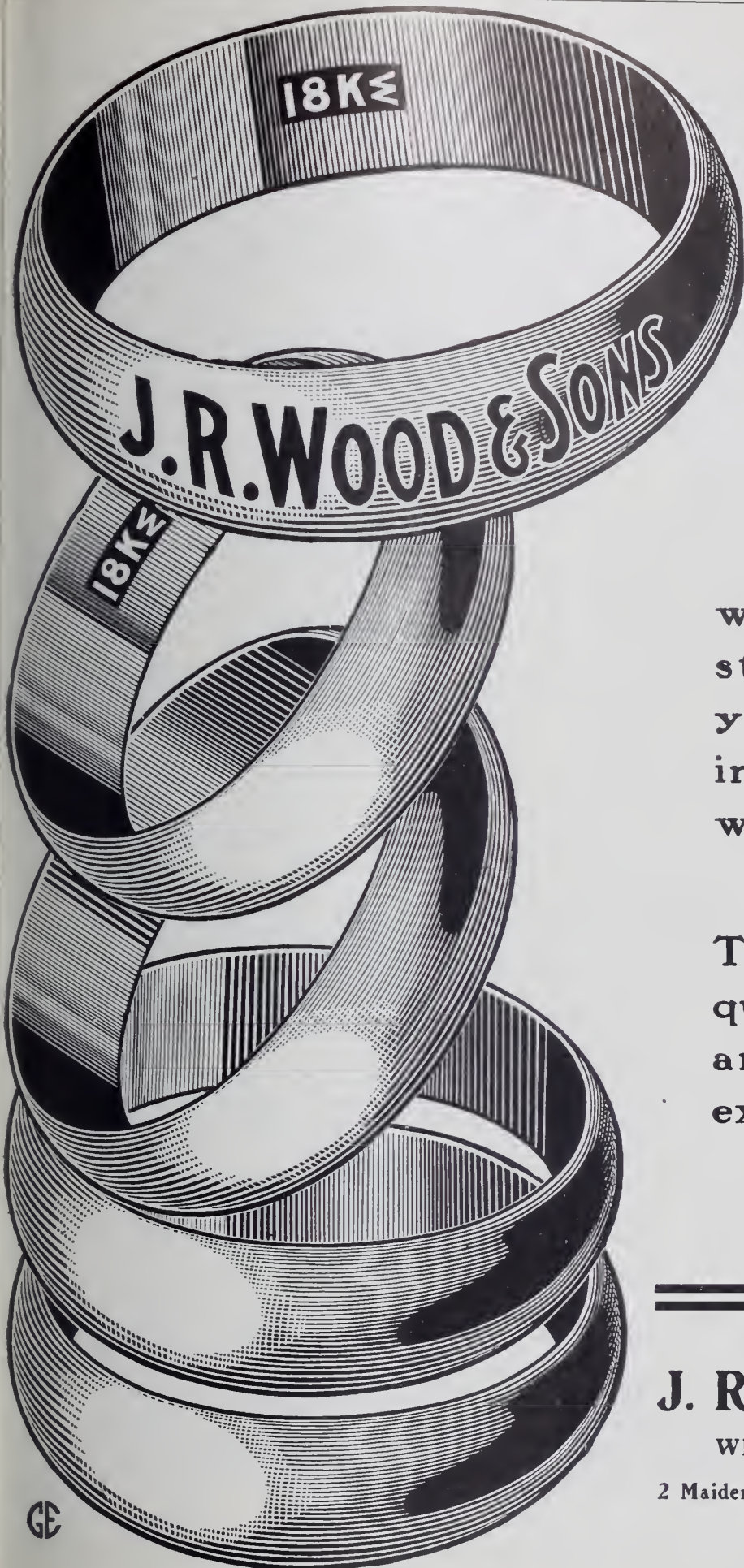

At The Top of the Heap

where they have stayed for **57** years; where we intend them always to remain.

The standard for quality, for finish, and for general excellence.

J. R. WOOD & SONS

WEDDING RING MAKERS

2 Maiden Lane Corner of 170 Broadway

NEW YORK

The Big Dipper

Will Dip Up Profits For You



THE
BEST IN EVERY
GRADE

CHICAGO
701 Heyworth Bldg.

Ask your Jobber

NEW YORK
Maiden Lane

STAR WATCH CASE CO.

LUDINGTON, MICHIGAN

COPYRIGHTED BY T. F. KENNEDY.



No. 69.



No. 48.



No. 40.



No. 61.



No. 64.



No. 63.

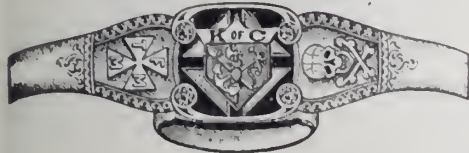

No. 71.

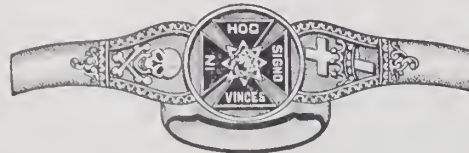

No. 67.



No. 73.



No. 51.



No. 44.



No. 66.



No. 99.



No. 22.

When you DO have a call for a fine Emblem Ring it is well to know that Wendell & Co. make the only line of high grade 14K. Rings on the market, that they carry a complete stock and gladly send a selection on memo. Their catalog shows illustrations of the entire line with list prices. They also make special Emblem Rings to order.

WENDELL AND COMPANY

The Special Manufacturers for the Retail Jewelry Trade

103-105 WILLIAM STREET, NEW YORK

57 WASHINGTON STREET, CHICAGO



The only manufacturers who make College Fraternity Pins for the trade. A complete assortment always in stock. Illustrated catalog shows the entire line with list prices. Manufacturing pins for local sororities and fraternities a specialty. Designs cheerfully furnished.

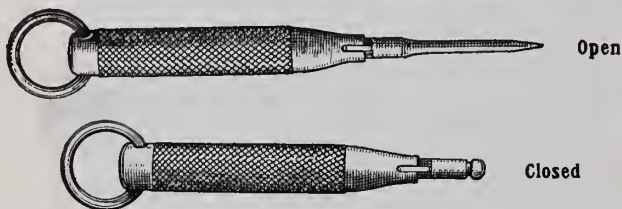

New Charm Eyeglass Screwdrivers No. 110, Reversible Blades, 15 Screwdrivers on a Display Card. Per Card \$1.75.

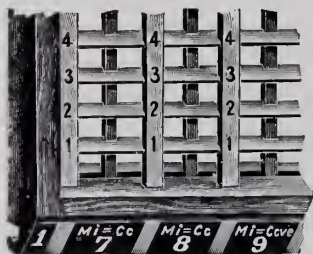

Top View, Showing Skeleton Frame of Drawer. Accumulation of dust and chips is impossible.

Spectacle and Eyeglass Strap Plier No. 105

Price, each, \$1.25

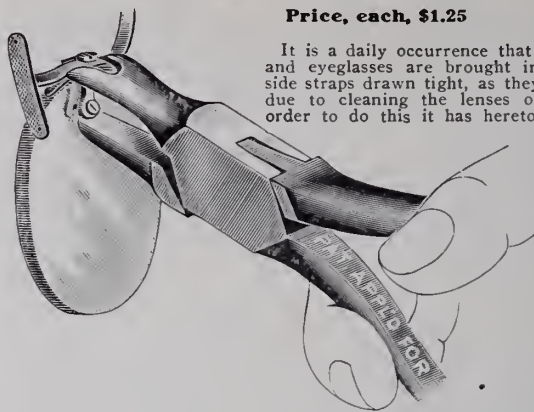

It is a daily occurrence that frameless spectacles and eyeglasses are brought in to have the small side straps drawn tight, as they have become loose, due to cleaning the lenses or other causes. In order to do this it has heretofore been necessary to remove the lenses from the mountings, and as all know, this very often results in breaking or chipping the lenses.

By the means of this plier this can be avoided and the work quickly done.

All that is required is to loosen the screw two or three turns, clamp the frame as shown in the illustration, and bend the straps to the lenses. Retighten the screw, and the work is done.

DO NOT NEGLECT to loosen the screw as otherwise a good job cannot be done, and the lenses are likely to be broken.

Made of best quality Swedish steel, nickel-plated.

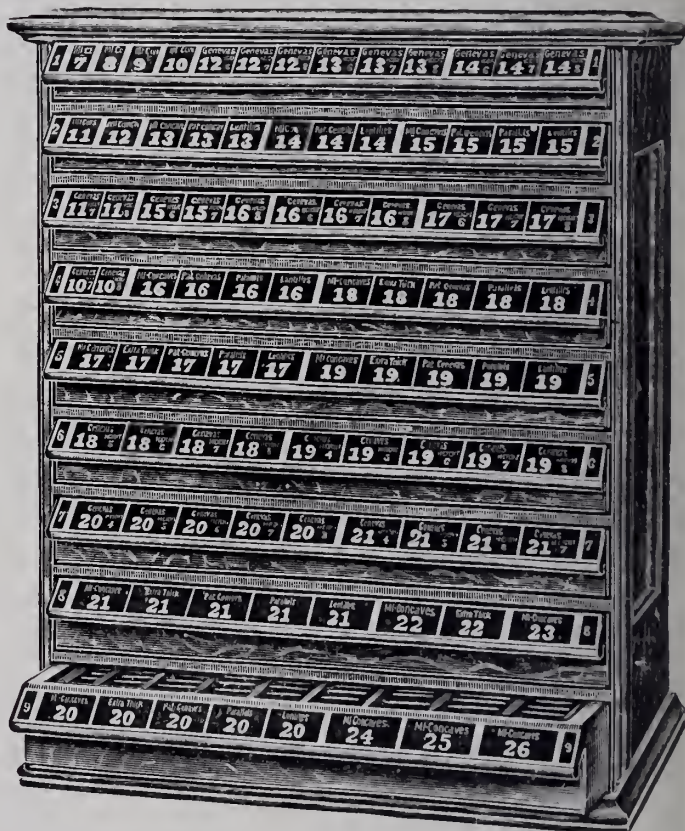

Echarco Watch Glass Cabinet No. 15 (Patented)

Price, each, \$16.00

This cabinet has many new features not found in any other. Novelty and usefulness are the chief arguments in its favor.

CONSTRUCTION AND MATERIAL.—The cases are made of oak, finely finished and of attractive appearance. Sides are paneled. Partitions of basswood and put together in best manner possible.

PARTITIONS are skeleton, preventing accumulation of dust, chips, etc.

BOTTOMS of cabinets are hollow to receive chips, dust, etc.

ARRANGEMENT FOR GLASSES.—The 9 drawers contain 1,547 spaces to hold glasses in upright position.

Labeling of drawers as shown in cut is on the pulls of the drawers and done in gold bronze on black background.

DIMENSIONS.—24 inches wide, 29 1/4 inches high, 12 inches deep; weight, 45 lbs.; with packing case, 75 lbs.

The construction of drawers, the arrangement of partitions to economize space and weight, and the novel method of showing contents on drawer-pulls are all prominent characteristics and extremely well thought of.

FOR SALE BY ALL JOBBERS IN THE UNITED STATES AND CANADA

HAMMEL, RIGLANDER & CO. 47-49 Malden Lane
New York

ONE
AND ONLY ONE
WADSWORTH 20-YEAR CASE

REMEMBER

THAT we make ONE LINE—and only one line—of 20-YEAR CASES.

THAT this one line is THE BEST on the market for the price.

THAT QUALITY AND STYLE are consistently maintained.

THAT the policy of ADVANCE and improvement has suffered no abatement.

THAT new and attractive DESIGNS continue to be added as heretofore.

THAT safety lies in buying the WADSWORTH 20-YEAR CASE.

A WORD to the wise is sufficient.

The WADSWORTH
WATCH CASE
COMPANY

NEW YORK
49 Maiden Lane
CHICAGO
Columbus Building
SAN FRANCISCO
717 Market Street

Factory: Dayton, Ky.



The
DUEBER
WATCH CASE

THE BEST



The more you know of the excellencies
of **DUEBER HAMPDEN WATCHES**
the surer you are that they are among
the finest watches America produces

WHITING MFG. COMPANY



Sterling Silver Vases

ESPECIALLY appropriate for gift purposes at this season of the year in connection with Easter and Spring Weddings.

A timely suggestion will be found by the Retail Jeweler in the attractive series here illustrated, which, though effectively decorative in design, is markedly moderate in price.



No. 893
6½ inches

No. 1893A
8½ inches

No. 2893
10½ inches

No. 3893A
12½ inches

No. 4893
14½ inches

The Whiting Company's line of vases is unusually comprehensive, ranging from examples such as are here shown to special pieces of the most elaborate and ornate character.

BROADWAY AND NINETEENTH STREET

San Francisco, Cal.,
717 Market St.

NEW YORK



A Seasonable Article

Would you not like to have some interesting information about one of our Spring and Summer Novelties?

A Traveler's Collapsible Chafing-dish, *indispensable* to tourists, yachtsmen, campers, excursionists, etc., desiring to prepare hot luncheons easily and quickly.

Full particulars and Catalogue 21, containing many specialties for the jeweler, sent on request.

S. STERNAU & COMPANY

New York Showrooms
BROADWAY, COR. PARK PLACE
Opposite Post Office

Makers of
Coffee-machines, Fancy Teakettles, Chafing-dishes
and their Accessories, Smoking Sets, Alcohol-
stoves, Coffee and Tea Pots, Candelsticks, Trays,
Baking-dishes, etc.

Office and Factory
195 PLYMOUTH STREET
BROOKLYN, N. Y.



The Original Carmen Adjustable Bracelet

With 20 years' experience and the best factory equipment that can be procured, we are able to produce

THE BEST IN THE WORLD FOR THE MONEY

The stamp, "The D. F. B. Co.," is a guarantee of quality and up-to-date designs. Ladies' and Gentlemen's Chains, Fobs, Lorgnettes, La Vallieres, Hat Pins, Chatelaine Pins and Bracelets.

THE D. F. BRIGGS COMPANY

ATTLEBORO, MASS.

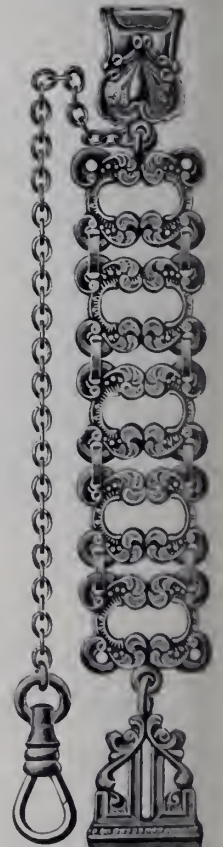

NEW YORK OFFICE
180 Broadway

CHICAGO OFFICE
Heyworth Bldg.

ST. LOUIS OFFICE
Mermod & Jaccard Bldg.

LONDON OFFICE
118-122 Holborn E. C.

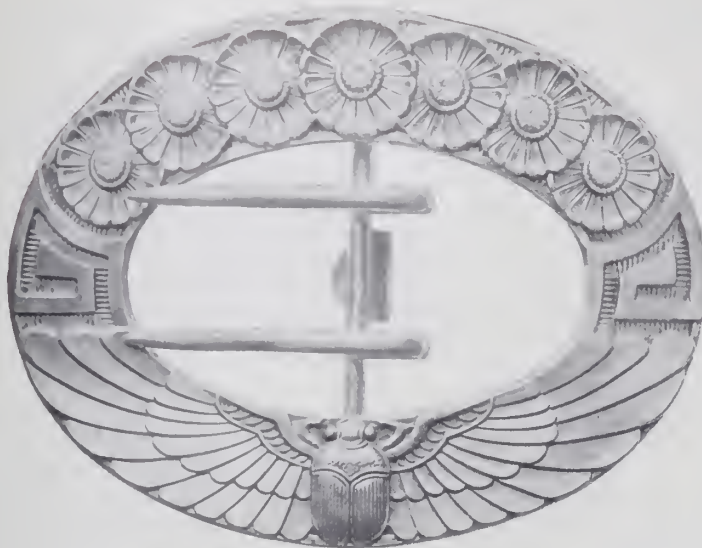

OUR new Buckle and Belt Pin Catalog is now ready and will be sent out in a few days. If you do not receive one, we will gladly send you a copy on request.

We met with such great success with our Buckles that we were encouraged to add from time to time a great many new pieces until we now have as complete and comprehensive a line as any jeweler could desire.

The accompanying illustration suggests one part of the line that we have developed in which is embodied the Egyptian character of ornament.

These Buckles are of heavy weight and no expense has been spared to give them the finest finish possible.

We take this occasion to thank the trade for the support they have given this part of our line in the past and would ask for a continuance of their favors.

R. BLACKINTON & CO.

Established 1861 TRADE  MARK SILVERSMITHS

FACTORY, NORTH ATTLEBORO, MASS.

3 Maiden Lane, New York

SOLD DIRECT TO THE RETAIL TRADE ONLY

FEATURES OF OUR LINE

The **UNIQUE, ARTISTIC and UNUSUAL**, together with **BEST WORKMANSHIP, SUPERIOR QUALITY and PERFECTION IN FINISH**



296

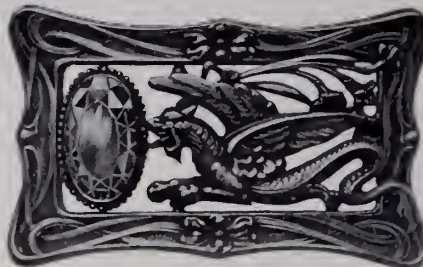

624

SASH BROOCHES
in gold-filled, finished in rose or dark green (antique).

Sash Brooches

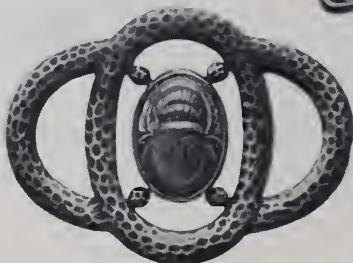

237



316

We use finest imitation stones and can furnish any stone or color required.

We Manufacture in **GOLD-FILLED** and **STERLING SILVER**

BROOCHES, HAT PINS, COMBS, HANDY PINS, WAIST PIN SETS, BARRETTES, SCARF PINS, VEIL PINS, LINKS, BUCKLES, SASH BROOCHES, BRACELETS and NECKLACES.

C. RAY RANDALL & CO., North Attleboro, Mass.

NEW YORK OFFICE, No. 7 Maiden Lane

SAN FRANCISCO OFFICE, Henry M. Abrams Co., No. 717 Market Street

Address all orders and communications to Factory, North Attleboro, Mass.

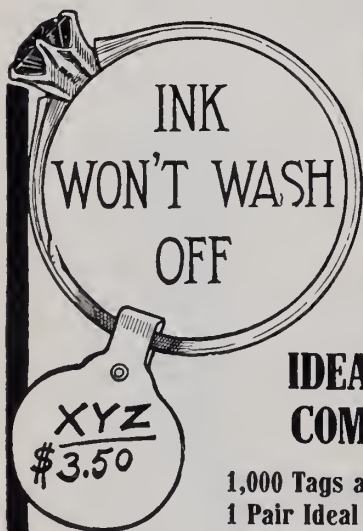

TAG YOUR RINGS WITH WASHABLE TAGS

IDEAL TAGGING OUTFIT COMPLETE, ONLY \$2.50

- 1,000 Tags and Eyelets, . . . \$1.50
- 1 Pair Ideal Pliers,75
- 1 Bottle Waterproof Ink,25
- 1 Neat Hardwood Box, with catch fastener

The **IDEAL CELLULOID TAG** is something that every jeweler should have, **BECAUSE IT SAVES TIME—AND SAVES MONEY.**

And because it gives your rings a more attractive appearance.

You don't have to take off the tags when you wash or polish your rings, because the ink that goes

with each outfit is waterproof, and won't wash off.

No danger of getting the tags mixed and getting them on the wrong ring.

The Ideal has a large flat writing surface, which makes it better than any other tag.

A complete outfit only costs \$2.50. Better send for it to-day if you want it soon, for the demand is very large.

Bastian Bros. Co.

30 South Avenue, ROCHESTER, N. Y.

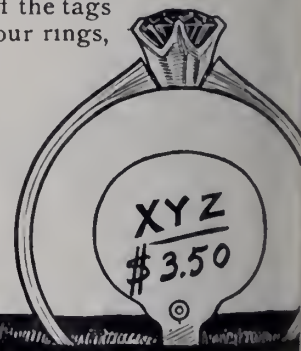

POSITION OF TAG WHEN RING IS IN TRAY

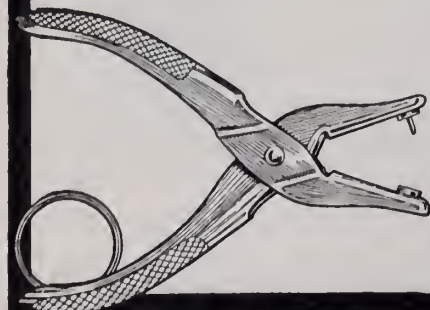



WE show herewith a new style bag—an exceptionally strong, stylish, snappy article.

Our new Spring line is complete—covering the entire range of bags—all shapes, all the different styles of mesh—the largest assortment of frames ever shown. Every piece stamped. W. & D. an absolute guarantee of satisfaction.

Your Jobber has them.

WHITING & DAVIS
PLAINVILLE (Norfolk Co.), MASS.

New York Office, 7 Maiden Lane

NEW YORK, 9 Maiden Lane
CHICAGO, 103 State Street

BATES & BACON ATTLEBORO MASSACHUSETTS

THE LEADING HOUSE FOR HIGH-GRADE GOLD-FILLED CHAINS, LOCKETS AND BRACELETS

Something New for Easter!

THE "WINNA" BRACELETS
Strongest secret joint and catch on the market

SOME OF OUR NEW DESIGNS
ORDER OF YOUR JOBBER

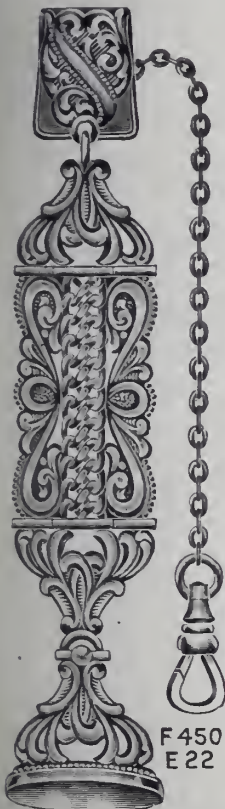

F450
E22



L.1261



L.1262

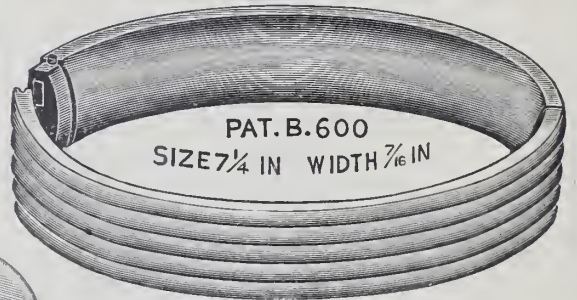
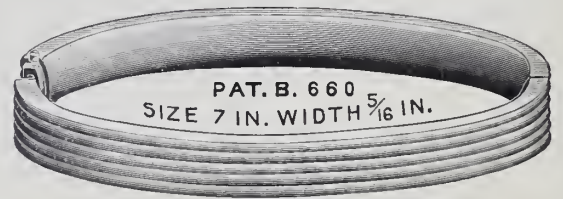

PAT. B. 661

The Best Selling "Thread" Pattern in the Trade



The SMITH "PILGRIM"

There never has been a more artistic and lasting design than the Smith "Pilgrim." It is characterized by simple elegance, refinement and dignity of design, and grateful absence of over-ornamentation. The Smith "Pilgrim" pattern will remain permanently in demand. Include "Pilgrim" in your stock. It is without question the best selling "thread" pattern in the trade to-day. Made in all the fancy pieces.

FRANK W. SMITH CO. MANUFACTURERS OF
STERLING SILVERWARE Gardner, Mass.



TRADE MARK

COMPLETE YOUR STOCK WITH RIGHT GOODS

GOLD RINGS

Gold Scarf Pins

Gold Brooches

A Handsome Line of Seamless Wire GOLD FILLED RINGS

All ready for prompt delivery to the Jobber

OSTBY & BARTON CO.
PROVIDENCE, RHODE ISLAND

New York Office
9-13 MAIDEN LANE

Chicago Office
103 STATE STREET



EASTER is the time of awakening and it brings with it a revival of the jewelry business. Many articles are called for, appropriate to the time and season, and the jeweler should be properly supplied. We have full lines of suitable goods: Crosses, Cuff Pins, Veil Pins, Locketts and Chains, also Fobs and Scarfpins, etc.; in fact, everything that may be desired in this line. They are all "Sellers," and we should be pleased to send memo. package upon request.

"Sellers
of
Sellers"

HENRY FREUND & BRO.

Diamonds
Watches
Jewelry

71 Nassau St., NEW YORK

Our Trade-Mark  "The Rose." stands for quality and excellence

毒

"Kotobuki"

毒

(Pronounced Ko-to-bu-ki)

THE JAPANESE WORD FOR LONG LIFE

The Popular Craze in

== SCARF PINS ==

Price in 14 Kt.
\$3.00

MANUFACTURED IN 14 KT. GOLD BY

Price in 14 Kt.
\$3.00

VAN DUSEN & STOKES CO.

MAKERS OF ORIENTAL JEWELRY

IMPORTERS OF CORAL AND SEMI-PRECIOUS STONES

1123 CHESTNUT STREET

- - - - -

PHILADELPHIA

...Announcement ...

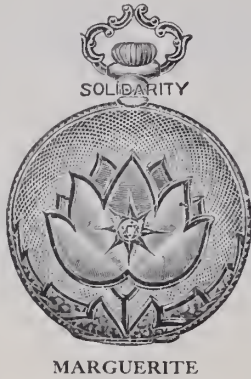

MARGUERITE

MR. RETAILER:

We are now ready to deliver through THE JOBBERS a new line of 14k. Gold 12s., O. F. plain bascine THIN MODEL cases, in LIGHT WEIGHT.

The production will be limited

BECAUSE

we cannot AFFORD to manufacture cases at this price under normal trade conditions.

Write for samples on Memo. from your JOBBER. Then TELEGRAPH your order.

Solidarity Watch Case Company

Established 1885

54 Maiden Lane, New York

General Selling Agents:

JOHN W. SHERWOOD

::

::

FRANK E. HARMER

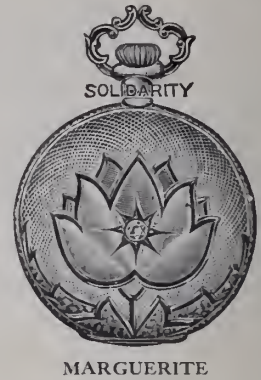

MARGUERITE

**SOME
TELLING
LINES**



**FOR
EVERY
JEWELER**

THERE'S A CHARM in the unique. This virtue exists to a marked degree in the lines enumerated below. They represent the foremost importations of their class—the unique and unusual. Designs being inspired by the old masters, each piece is a study. Every jeweler should carry examples. Representatives always in the field. See the Lines.

**SASH PINS—VEIL PINS—HAT PINS—BUCKLES—BROOCHES
NECKLACES—CHAINS—COMBS—JET GOODS**

D. Lisner & Co. *Creating Importers of* **Jewelry Novelties**
One-Forty Fifth Avenue, cor. 19th St., NEW YORK

The Latest Spring Novelties in Cloisonne Enamel Jewelry



Send for color illustration showing more attractions in designing novelties which greatly excel anything before conceived. These are all made in sterling silver and are especially adapted to Spring and Summer trade.

SHEPARD MANUFACTURING COMPANY
MELROSE HIGHLANDS, MASS.



H. F. GRUSCHOW
Compiler of Jewelry Catalogs

¶ Mr. Retail Jeweler:

¶ Are you interested in a beautiful catalog? One that you can send to your trade and one that will reflect credit upon your establishment?

¶ Well, we are preparing a fine catalog of this nature and are offering it to the trade with no strings attached to it either.

¶ Just think for a moment what our proposition means to you:

First: You can buy goods when you please.

Second: When you are ready to buy you make your purchases *direct from the manufacturers themselves.*

Third: We are in the catalog business pure and simple and therefore can offer you the best proposition that your money can buy.

¶ The illustration in colors on the opposite side of this sheet is a sample of one of the colored pages that will be contained in our book.

¶ The Shepard Mfg. Co. will have a representation in our book in colors similar to this sample.

¶ We sell this catalog to only one jeweler in a town, so, if you are interested, drop us a line at once.

Peninsular Engraving Company

Detroit, Michigan

(See other side of this page)

REMEMBER THE GUARANTEE IF FOR ANY REASON WITH THE ACCENT ON ANY

IF FOR ANY REASON THIS CHAIN IS NOT SATISFACTORY TO THE PURCHASER, IT CAN BE RETURNED TO THE MAKER AND A NEW CHAIN WILL BE GIVEN IN EXCHANGE

AUSTIN & STONE, INC. Attleboro, Mass.

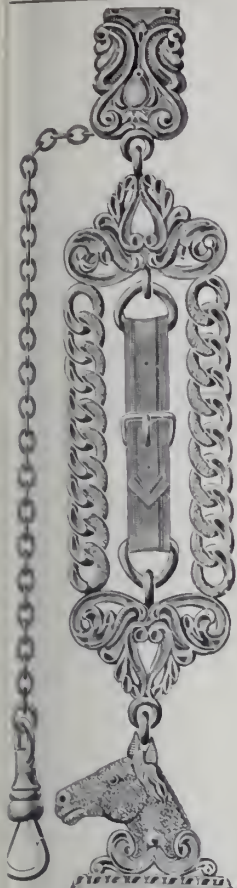

N104/54

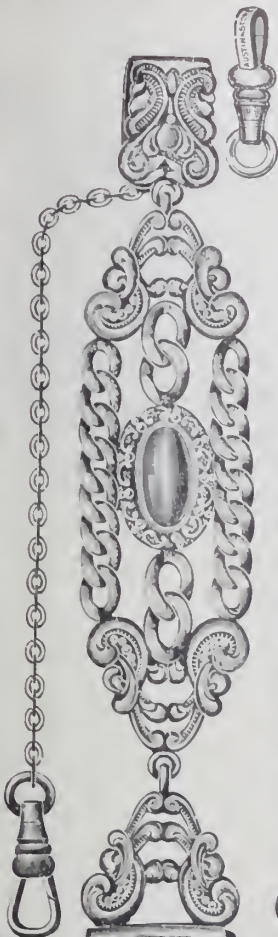

N113/62

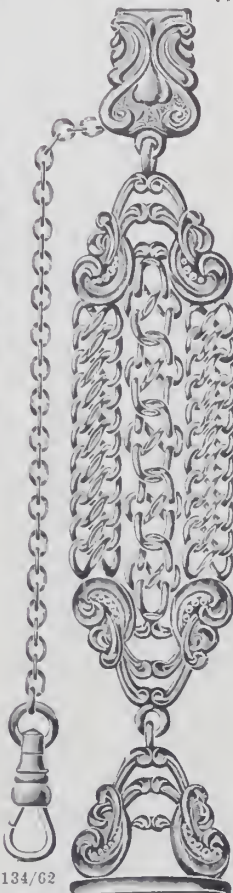

N134/62



N132/48



N129/38



N111/91



B5009

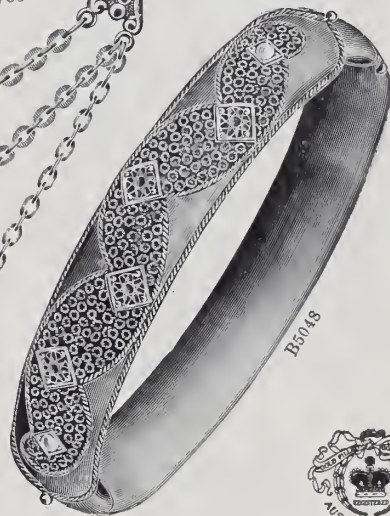

B5048



B5021



B5097

AUSTIN & STONE Incorporated. ATTLEBORO, MASS.

SOLD TO JOBBING TRADE ONLY

L12040

*The
Season's
Best*

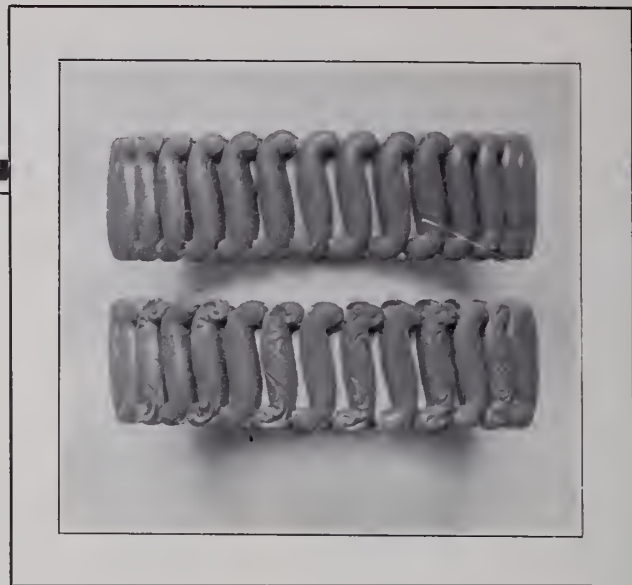

Seller in extension bracelets—

SIMMONS Adjustable Bracelet

Uniquely simple in construction, positively perfect in operation—the most practical and serviceable bracelet of this type that has yet been offered.

The SIMMONS Adjustable Bracelet is made of 1/10—12K. gold-filled stock (regular Simmons quality).

It is neater, more graceful in design, and of higher grade stock than the usual adjustable bracelet—thereby appealing to a better class of trade—and can safely be counted a first-class seller from the start.

Get a trial dozen from your jobber.

R. F. SIMMONS COMPANY, Main Office and Works, Attleboro, Mass.

New York Salesrooms,
9-13 Maiden Lane.

Chicago Salesrooms,
42 Madison Street.
(Heyworth Building.)

The KREMENTZ MATCH BOX

made expressly for paper matches, in 14-Kt. Gold and Sterling Silver, with the following finishes:
Roman, polished, engraved, engine turned and the Krementz gun metal finish.

Open



Side View
Closed



Order No.
in 14-Kt. Gold
2117

Front View
Closed



Order No.
in
Sterling
Silver
2043

The side and front views show its compactness. It opens and closes easily and fits the vest pocket, taking very little space.

KREMENTZ & CO.

Manufacturers of

Fine Gold and Enamel Diamond Jewelry in 14-Kt. Only

MADE EXCLUSIVELY FOR FINE RETAIL JEWELRY TRADE

BRANCH
San Francisco Office
722 Shreve Bldg.

Factory and Main Office
NEWARK, N. J.

BRANCH
New York Office
1 Maiden Lane

ELEMENTS OF STRENGTH AND FORM



INCONSPICUOUS though it is the Collar Button means a lot of comfort—or discomfort. It depends on the make, the strength, the form. Durand Collar Buttons are smooth and shapely—therefore comfortable. Free from mechanism—therefore durable.



PRICES: \$1.15 to \$4.00

DURAND & CO.

49-51 FRANKLIN STREET
NEWARK, N. J.



ENOS RICHARDSON & CO.

23 Maiden Lane New York, N. Y.

Trade-Mark

MANUFACTURERS OF
14 K. GOLD JEWELRY

- | | | |
|-------------|-----------------|------------|
| Handy Pins | Dumb-Bell Links | Hat Pins |
| Safety Pins | Fobs | Scarf Pins |
| Brooches | Tie Clasps | Barrettes |
| Flat Links | Veil Pins | Belt Pins |

10 K. and 14 K. Neck Chains
and Guard Chains

Plain and Jeweled Lorgnette Chains



The R. S. Cigar Cutter

In Sterling Silver, Plain and Engraved; and 14 k. Gold, Plain and Engraved, also Set with Diamonds.

A Novelty

Unlike all other cigar cutters, this one lies flat in the pocket—does not get out of order.

A Good Article



We Push It

Our advertising makes the customer want it; his friend sees it and he wants it. An endless chain of customers.

A Good Seller



Trade supplied by

Enos Richardson & Co.

23 Maiden Lane, New York.

C. R. HOWE
W. T. CARTER
W. T. COUGH

ESTABLISHED 1841 BY A. CARTER

F. R. HORTON
F. W. STANBROUGH
H. L. FARROW

CARTER, HOWE & CO.

MANUFACTURERS OF

GOLD JEWELRY

ARTISTIC—SALABLE—RELIABLE

Most Comprehensive Line Offered

9-11-13 Maiden Lane, New York

Factory, Newark, New Jersey



SOLID GOLD CHAINS

bearing our trade mark stand for the highest achievement in gold chain manufacture. Plump quality, perfect workmanship, careful finish and attractive designs—all combined—distinguish our product.

WE SELL DIRECT TO YOU

No intermediaries, no corps of salesmen, no unnecessary expenses to add to the price—just the cost of the gold, the cost of making and a modest profit for ourselves enable you to buy the best chains at the lowest price. SEND FOR CATALOGUE.

ALOIS KOHN & CO.

16-18 MAIDEN LANE, NEW YORK

Gold Chains of Every Description

The Allsopp Rings

The Up-to-Date
Line of

Signet and Set Rings



In twenty years we have built up a business second to none in RINGS EXCLUSIVELY

Allsopp

QUALITY,
DESIGN AND
WORKMANSHIP

Appeal to the Most Fastidious.
It Will Pay You to Examine
a Selection Package.

A ★
TRADE-MARK.

Allsopp Bros. Allsopp Building, Newark, N. J.

UNIQUE GEMS

I am showing an entirely new lot of NATIVE, CEYLON, URAL and BRAZIL semi-precious stones, in new and fancy cuttings as well as cabochons. ALL GENUINE. Sample papers sent to reliable dealers.

Louis J. Deacon, CAPE MAY N. J. (Summer headquarters)

TRADE



MARK.

SNOW & WESTCOTT CO.

21 MAIDEN LANE, NEW YORK

JAMES P. SNOW

CHAS. E. WESTCOTT

Makers of Fine Gold Jewelry

ESTABLISHED 1834

Patent Neck Snap Hold-Fast



Impossible to lose a neck chain
equipped with a Hold-Fast Snap

We make the largest, most varied
line of Cuff Buttons shown to the
retail trade, also Locketts, Scarf Pins,
Rings, Brooches, Crosses, Fobs, Neck
Chains, Lorgnette Chains, Etc., Etc.

The Keller Jewelry Mfg. Co.

64 Nassau St., New York

Factory: Newark, N. J.

"THE BRACELET HOUSE"

GOLD BRACELETS of every kind
For WOMAN, MISS OR BABY

KENT & WOODLAND

16 John Street, New York

Factory: Newark, N. J.

San Francisco: Julius A. Young

HILL & SCHMIDT

71 Nassau Street

NEW YORK

Makers of Artistic 14 kt. Jewelry

SPECIAL DESIGNS IN

LA VALLIERES and HANDY PINS

LOUIS G. SCHLEHR

MANUFACTURING JEWELER

178-180 Ellicott St., Buffalo, N. Y.

All Out-of-town Work returned within 3 days from date received

Rings, Diamond Mountings,
Diamonds and Precious Stones,
Badges, Class Pins

General Repairing Artistic Engraving

Easter Lily Hat Pin



THIS is one of the most
felicitous creations ever
placed at the disposal of the
trade.

Made in the size shown
above, as well as smaller. Also
in cluster form.

Baroque Pearl center. Some
with diamond "dew drop."

Scarf Pins in same form.

Prices moderate



Day, Clark & Co.

Makers of 14-kt. Jewelry

23 Maiden Lane
NEW YORK



Black Enameled Jewelry

OUR SPECIALTY

THE reports from the fashion centers of the world are that

Black Jewelry

of all kinds, both for mourning as well as regular wear, is the latest fad.

Jewels of all kinds mounted this way show up to their best advantage.

We Make Everything in Black

A. J. Hedges & Co.

MAKERS OF 14 K. JEWELRY

14 John St., New York

TRADE



MARK

I. N. LEVINSON, President

ESTABLISHED 1865

H. S. MORRIS, Sec. and Treas.

S. COTTLE COMPANY

Makers of High-Grade Gold, Silver, Gun Metal Novelties



- Mesh Bags
- Buckles
- Card Cases
- Chatelaines
- Vanity Cases
- Sash Pins
- Purses
- Hat Pins

S. COTTLE CO.

31 EAST 17th STREET
NEW YORK

PARIS, 28 Rue D'Hauteville

ACTUAL SIZE.

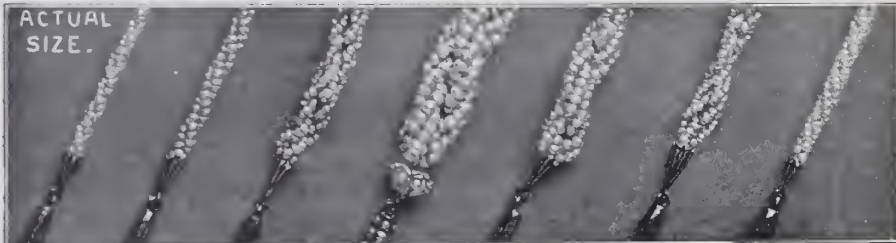

SEED-PEARL NECKLACES IN ALL SIZES.

OSMERS-DOUGHERTY CO.

MANUFACTURING JEWELERS

291-293 SEVENTH AVE., NEW YORK

Bet. 26th and 27th Sts. Telephone, 913 Madison.

DEALERS IN
BAROQUES, PEARLS and
FANCY STONES



DESIGNING
AND
SPECIAL ORDER WORK

Roger Williams Silver Co.,

PROVIDENCE, R. I.

Sterling Only.

RICH DESIGNS :: :: :: Photos. on Application.

CHARLES M. PRIOR, Designer

Designs for Gold and Silversmiths.

I have added Ornamental Engraving to my Etching Department.

'Phone 1639 Gramercy

24-26 East 21st St., NEW YORK

"If It Is Chopard's Idea, It's Ideal"
COLLARS and NECKLACES

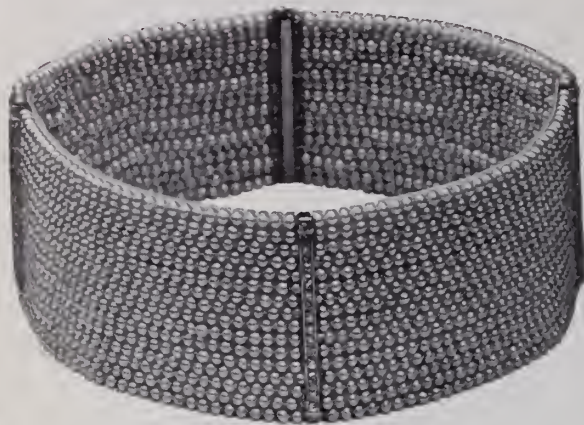

PEARL COLLARS: every width, every quality in stock or mounted to order.

JET COLLARS: fancy mounted Jet or Jet Bead Collars, both dull and bright in every width and length in stock.

NECKLACES: Pearl; Jet, dull and bright; and greatest variety of newest models in fancy novelty Necklaces and La Vallieres.

REMEMBER OUR SPECIAL DEPARTMENT created for you. For Restringing and Mounting Pearls, Pearl Collars, as well as Jet and other Bead Collars at Moderate Rates.

Selection Packages sent upon request to all reliable dealers

CHOPARD FRÈRES CO.

Factory, 35 Rue des Trois Bornes, PARIS, FRANCE

56 Maiden Lane, NEW YORK, N. Y.

SOLID GOLD BUCKLES AND SASH PINS

PLAIN AND ENGRAVED



14 K. — Everything in Gold Jewelry — 10 K.

Brooches, Links, Bracelets, Scarfs, Fobs, Locketts, Hat Pins, Festoons, Emblems, Gold Novelties, Pendants, Earrings, Combs, etc.



2 Maiden Lane, New York

BROOCHES

Just now cameo and single stone Brooches are holding the center of the stage, and every Jobber should have at least a few numbers in his lines this spring. The business conditions make it necessary for you to keep abreast of the times. Let us send you a few samples on memorandum.

THIS TRADE-MARK on every piece of jewelry that leaves our factory. A medium-priced line of 10K. jewelry that has stood the test. Will say no more, but let us show you and be convinced yourself.

Send for further information regarding our extensive line.



1109



1110 Amazonite

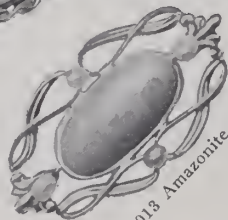

1013 Amazonite

W. E. RICHARDS CO.

Manufacturers for the Jobbing Trade
 ATTLEBORO, MASS.

New York Office: 12-14 John Street Samples only

Geo. O. Street & Sons

35 Maiden Lane, New York

Established 1837



RINGS
 SLEEVE-LINKS
 SCARF-PINS
 FOBS AND SEALS



No. 58

THE ARCHIBALD-KLEMENT LINE OF

SILVER DEPOSIT WHISKY BOTTLES

Distinguishable for their dignity of design and excellence of finish. Made in full quart size, four designs—Narrow Strap, Broad Strap, Rye, Thistle. Shield space for monogram, sterling silver corkscrew tops. Highball and whisky glasses to match each design.

Full line of the foregoing, and any other desired pieces in the A-K Silver Deposit Ware, sent on approval.

ARCHIBALD - KLEMENT CO.
 Sample Rooms: 341-347 Fifth Ave., N. Y.
 Factory: NEWARK, N. J.



J. E. ROHRBECK
 MANUFACTURER
 40 FULTON ST.
 NEW YORK, N. Y.

SEND YOUR SWEEPS to the Cincinnati Gold & Silver Refining Co.

REFINERS, ASSAYERS AND SMELTERS
 Office, 523 Elm Street; Works, 2257 Eastern Avenue; CINCINNATI, OHIO

Highest Price Paid for Gold, Silver and Platinum Platinum and Gold Fillings Refined by the Russian Method

HAT PINS FOR THE NEW EASTER HAT

A large variety of novel and unique designs mounted with amethyst, topaz, lapis, coral, nephrite, etc.

As a special we offer genuine amethyst, topaz, crystal and lapis pins at a low figure.

Send for selection, mentioning price.



Fans in endless variety from the cheapest to the best for weddings, confirmation and graduation.

Necklaces, Buckles, Belt Pins, Brooches, Collars, Fan and Lorgnette Chains, Pearl Button and Pearl Drop Earrings, also choice specimens in Cameos.

LEWY & COHEN

IMPORTERS

530 Broadway Cor. Spring St.
NEW YORK

The Bowden Rings

ARE COMPLETE IN VARIETY, CORRECT IN QUALITY AND PERFECT IN FINISH. WE MAKE EVERY VARIETY OF FINGER RINGS.

J. B. BOWDEN & CO.,

1 Maiden Lane,

NEW YORK.

Shell Cameo Brooches and = Belt Pins =

IN STERLING SILVER
FLORENTINE WORK

FROM

\$3.25 to \$7.00 Each

Send for a choice selection
on memorandum



M. GUGENHEIM, Importer

Brooches, Festoon Chains, Combs, Hat Pins, Collars, Jet Goods, Mesh Bags, in German Silver, Gilt Metal and Sterling

NEW YORK OFFICE

33 Union Square, Decker Building

PARIS

32 Faubourg Poissoniere

¶ While in Italy I anticipated the daily growing demand for Cameos, and accordingly negotiated for such quantities as now enable me to uninterruptedly meet the heavy call for these goods.

CROUCH & FITZGERALD



Jewelry Trunks and Cases

177 Broadway,
Bet. Cortlandt
and Dey Sts.
688 Broadway,
723 6th Ave.,
New York.

DIAMOND MOUNTINGS

of any description in gold and platina

Order Work a Specialty

HENRY BASCHKOPF

47-49 Maiden Lane

New York, N. Y.

LOCKETS ONLY

Registered



U. S. Pat. Office



Pat. Applied for
NUMBER
8482

Latest Design Appropriate for Easter

WIGHTMAN & HOUGH CO.

NEW YORK OFFICE
3 Maiden Lane

Main Office and Factory } 7 Beverly St.
PROVIDENCE, R. I.

S. F. Myers & Co.

WHOLESALE JEWELERS
47-49 Maiden Lane
New York

Words are good when backed by deeds, and only so. We back our words to the limit.

For the trade only—our new, big catalogue, with 100,000 items, sent free.



LA VIGNE TEASPOON



LA VIGNE TABLESPOON



LA VIGNE MED. FORK

The latest and newest in
ROGERS FLATWARE

HAVE YOU SEEN IT?

Bright or French Gray. Sample dozen on approval. Write for prices and terms.

JOSEPH IRONS, 35 Maiden Lane

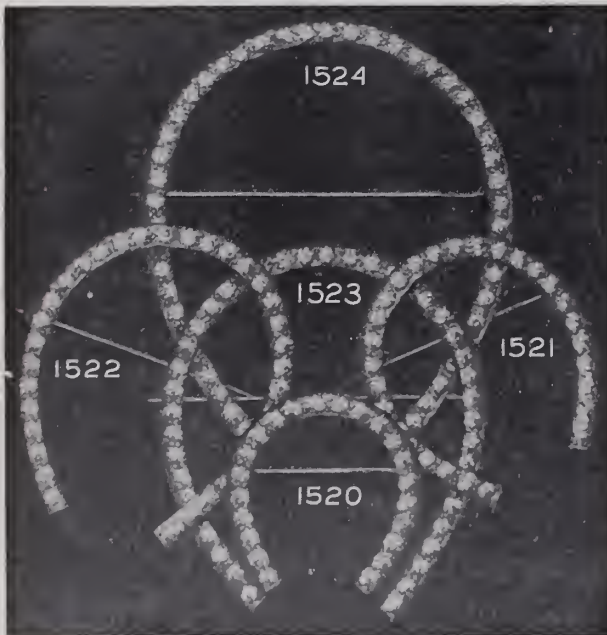

Sterling Silver Horseshoes

14 Karat Gold Finish set with Whitestones or Pearls

Write for Selection Package with Prices

Wachenheimer Bros. 36 GARNET STREET PROVIDENCE, R. I.

WM. SMITH & CO.

OFFICE: Established 1854. MANUFACTORY:

9-13 Maiden Lane, New York 61 Peck St., Providence, R. I.

Manufacturers of GOLD AND SILVER CHAINS
GOLD, SILVER AND PLATED CHAIN TRIMMINGS

Also GOLD AND SILVER KEY CHAINS AND BRACELETS

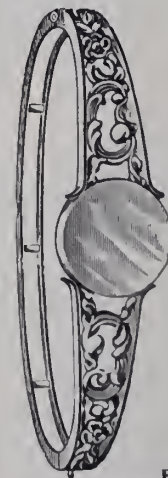

10K. GOLD BRACELETS

New and Original Designs in—

BANGLE, JOINT AND CATCH SIZES

Scarf Pins, Ladies' Rings Earrings and Handy Pins

in a great variety of designs

TRADE MARK

THE Edwin Lowe & Co., Inc. F.W. BODWELL, Pres. & Gen. Mgr.

116 Chestnut St., PROVIDENCE, R. I.
New York Representative: Western Representative: E. T. Wilson, 180 Bway. S. H. Brower



Fancy Platforms and Blocks for Window Display.

Trays, for Show Cases and Travelers' Use, of every description.

Jewelry Boxes in many qualities and styles.

Boxes for silverware, Manicure and Toilet Sets.

Silverware Chests in any combination.

Flannel Rolls and Bags for Silverware.

We Re-cover Window Platforms and Trays.

PAPER BOXES.

Tags, Cards, Cotton, Findings, Etc.
Estimates and Samples Cheerfully Furnished

WOLFSHEIM & SACHS

Office and Salesroom:

35 Maiden Lane,

(Lorsch Building)

NEW YORK

Factory: 10 Gold Street, N. Y.

A NEW CREATION IN

Hat Pins



Made of the finest brilliant Rhinestones. Can be sold for less than the imported ones. They come in pear, ball and half ball, octagon and heart shapes, and can be retailed from

50c.

to

\$5.00

at a handsome profit. Ask your jobber or write us for sample assortment.

ACME COMB AND NOVELTY CO.

Manufacturers

Factory and Office
147 Spring St., New York
Salesroom: 194 Broadway

P
&
B

S
T
I
C
K
P
I
N
S

POTTER & BUFFINTON'S
PROVIDENCE, R.I.

In endless variety to please the most fastidious.
We are the largest exclusive makers of 10 Karat Jewelry.
Ask your Jobber for our lines of Scarf Pins, Cuff Buttons, Lockets, Baby Pins, Fobs, Brooches and Crosses.

New York Office 65 Nassau St. San Francisco Office Mutual Bank Bldg.

56 55 49

782 740

512 91

733 752

93 55 50

MONOGRAM AND INITIAL SPOTS

For Bags, Purses, Cases and Toilet Sets. Made in 14 Kt. Gold, Sterling Silver, Gold Plate and Hard Enameled; also Stencil Spots. TO THE TRADE.

WALDRON & CARROLL, 34 Warren St., New York City

"BOUGHT BY ALL"

New York City
and
American Jewelers

"A Good Recommendation"



VERIBEST

Label Mark



Lifetime Guarantee

LOCKETS

VERIBEST Locketts Sold by Jobbers Everywhere

S. & B. LEDERER CO.

QUALITY WEARS GOODASGOLD

New York City: 9-11-13 Maiden Lane Providence, R. I.: 100 Stewart St. Chicago, Ill.: 131 Wabash Ave.

The Thimble House.



No. 149.

Thimbles are not a side line with us—They are our main business. We study Thimbles, our designers study thimbles, our workmen study thimbles—The result is the finest and largest line of Thimbles on the Market.

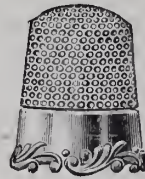

No. 136.

KETCHAM @ McDOUGALL,

Manufacturers,

37 @ 39 Maiden Lane, New York.

Send for Catalogue.

Established 1832.

ALSO MAKERS OF THE NEW AUTOMATIC EYE-GLASS HOLDERS.

Send for the Latest Styles in MONOGRAMS AND INITIALS

as manufactured by

THOMAS J. DUNN CO.

101 Chambers St., New York
Makers of exclusive styles in

MONOGRAM FOBS

in Gold, Sterling and Rolled Gold Plate. Our 1908 Ladies' Belt Buckles are most original and artistic.

Specialties in the Monogram and Initial line.

Send for Illustrated Sheets.



Perennially Popular

THE best evidence of the popularity of our various lines is the increasing demand for them and our consequent growth. Our jewelry is unexcelled in every quality that contributes to serviceability and appearance. The designs are artistic enough to court that investigation which results in sales.



No. 117

Ask to see our line of

**CHAINS
CHAIN PENDANTS
CROSSES
AND BRACELETS**

The
**Kenilworth
Bracelet**

particularly, the strongest on the market.

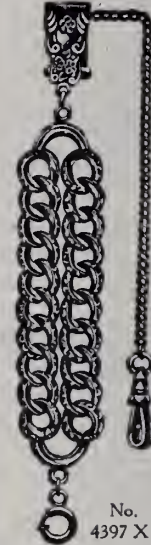

No. 4397 X I

**DORAN,
BAGNALL @ CO.**

North Attleboro, Mass.

OFFICES

New York: 194 Broadway.
Chicago: 42 E. Madison St.
San Francisco: 91 Drumm St.

THE WASHBURN

SECURITY **MAGIC NUT**
Automatic Holder for ear studs, scarf pins etc.
for all sizes of scarf-pin wire. Guaranteed.



EAR WIRES
for unpierced ears.



SAFETY CATCH
For Brooches, etc.
Can be applied to any work where pin tongues are used.



Open. Closed. Open. Closed
Descriptive Circular on Application
Pearl Drilling and Adjusting a specialty.
Special Order Work and Repairing
C. IRVIN @ WASHBURN, 12-16 John St., N. Y.

THE CROHN PATENT SAFETY GUARD



For Scarf Pins, Pins. The most adjustable one invented. Price, \$1.50 per doz. For sale by all wholesale jewelers and material houses. Sample by mail, 25c.; in 10k. gold, \$1.00; 14k., \$1.25. **M. CROHN** Maker and Inventor, 48 and 50 Maiden Lane, N. Y.



After May First

Our New York Office
will be

Rooms 1706 and 1707

Silversmiths' Building

15-17-19 Maiden Lane

Telephone Connection

**E. L. SPENCER
COMPANY**

Makers of
Solid Gold Jewelry

Factory:
95 Chestnut St., Providence, R. I.



To
Release
Pull
the Ball

SHUROLDA



To
Release
Pull
the Ball



Automatic Scarf Pin Protector



14 Kt. Gold Plate

Price 50 Cents

Pat. Mar. 12, 1907. No. 847,164. **The Stronger the Pull the Firmer It Holds** Pat. Mar. 12, 1907. No. 847,164.

Samples and Prices on Application

FOR SALE BY JOBBERS OR DIRECT BY

STERN & CORN, 71-73 Nassau St., NEW YORK

EVERYTHING IN LOCKETS AND CHAINS.

THE BASSETT JEWELRY CO.,

PROVIDENCE, R. I.



Seamless Gold Plated Pins

FOR EVERY USE

Variety of Patterns in
Plain and Engraved, in
lengths one to four
inches : : : : :

GUARANTEED GOLD
FRONT, BACK AND SIDES

SEND FOR SELECTION

**Maintien Bros. &
Elliot**, Makers of Jewelry
for the Jobbing Trade

NO. ATTLEBORO, MASS.

New York Office, 9-11 Maiden Lane

THE "HOLDWELL" COLLAR and BOW PIN

50 designs, 3 sizes, for small, medium and large bows.
To retail at from 50c. to \$1.50.



ON THE BOW

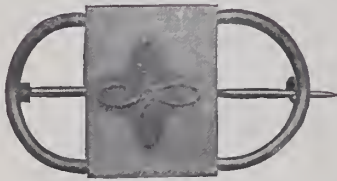

FRONT

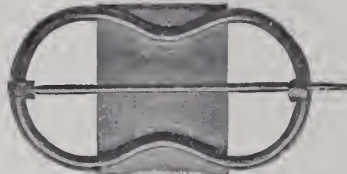

BACK

A Seasonable Novelty. Holds the bow without defacing it, and securely pins the collar. The bow is easily inserted from the back. Simply open pin tongue, and slip ends of bow through wire loops one end at a time. The popularity of ladies' bow ties makes its sale assured.

TO THE WHOLESALE TRADE ONLY.

Send For Samples At Once.

E. A. POTTER COMPANY

Providence, - Rhode Island

- 1. Snap complete.
- 2. Outside of snap.
- 3. Inside of snap.

The E. P. H. Patent

NON-PULL-OUT Neck Chain Snap

is a patented snap that insures the wearer against loss of

CHAIN or CHARM

for it positively will not pull out

Made in 10 and 14 Karat Gold and in Gold Filled.

Can be had of the following Wholesale Selling Agents:

- Messrs. W. Green & Co.,
81 Nassau St., New York
- | | |
|------------------------------|-------------------|
| M. Sickles & Sons, | Philadelphia |
| E. A. Cowan & Co., | Boston |
| E. & J. Swigart, | Cincinnati |
| Swartchild & Co., | Chicago |
| Nordman Brothers, | San Francisco |
| Leonard Krower, | New Orleans |
| A. Walker Co., | Providence, R. I. |
| Bauman-Massa Jewelry Co., | St. Louis |
| H. S. Meiskey Co., | Lancaster, Pa. |
| The Edw. Lehman Jewelry Co., | Denver, Col. |

PRICES.

- 14 Karat—Small, \$7 per doz. net
Large, \$7.50 per doz. net
- 10 Karat—Small, \$6 per doz. net
Large, \$6.50 per doz. net
- Gold Filled—Small, \$2 per doz. net
Large, \$2.25 per doz. net



Try Wells' Perfect Ring Adjusters

1 doz. asst. sizes 10k gold filled (gold on front twice as thick as on back), \$2.00.
1 doz. asst. sizes solid 10k gold, \$3.75.
1 doz. asst. sizes, metal, 85c. Ask your jobber for them, or I will send, prepaid, at once (only on receipt of price), two samples—one small and one medium large gold filled and one metal adjuster for 50c. Address

CHESTER H. WELLS, Jeweler, Meshoppen, Pa.

Gems and Precious Stones

Cloth, Postpaid, \$1.00. Published by the Jewelers' Circular Pub. Co., 11 John St., New York.



Veil, Cuff and Baby Pins

An immense line. Many new designs supplementing our staple patterns—all of acknowledged beauty and easily sold.

Cameos A revival of an old-style decoration too good to remain in oblivion.

Shell, Coral and others, mounted as Brooches, Stick Pins, etc.

Swastika Buckles Bracelets Buttons Charms Brooches Barrettes

Combs, Hat Pins, Scarf Pins, Leather Trimmings

MILLER, FULLER & WHITING CO.

Manufacturing Jewelers
New York Office, 9-11 Maiden Lane NORTH ATTLEBORO, MASS.
WE SELL TO THE JOBBING TRADE ONLY



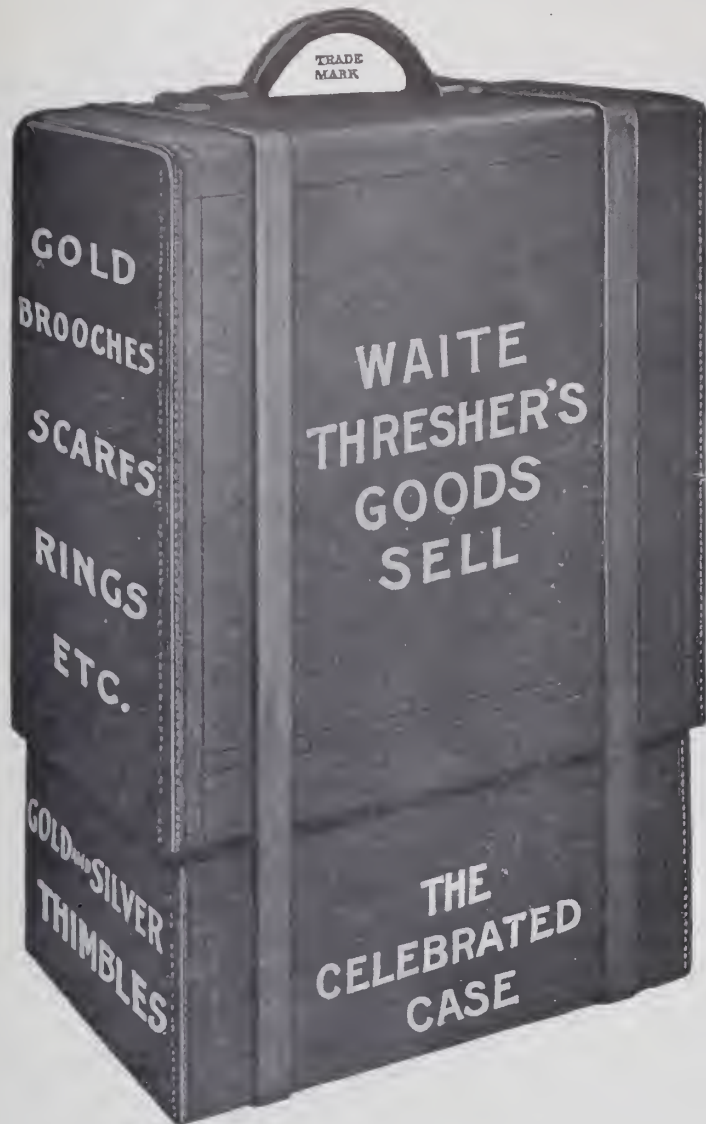

NEW YORK OFFICE
No. 7 Maiden Lane

CHICAGO OFFICE
1203 Heyworth Building

O. M. DRAPER CHAINS

ALL KINDS OF VEST CHAINS
PRINCESS, NECK AND GUARD CHAINS

We do not make as much noise as some of our friends but we are "there with the goods" and the *Jobbing Trade* handling our product for the last half century, know that our QUALITIES are genuine and can be depended upon, that our FINISH is unparalleled and that our prices are consistent.

If you do not handle O. M. DRAPER GOODS, we both lose.
We sell only to the Jobbing Trade.

Estate of O. M. DRAPER
Factory, No. Attleboro, Mass.

NEW YORK OFFICE
37 Maiden Lane

SAN FRANCISCO
506 Chronicle Building

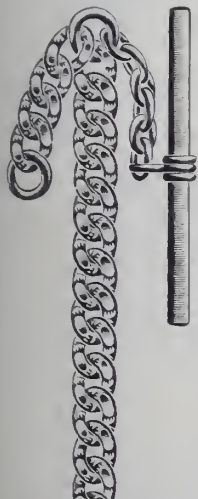

PLATEAUX

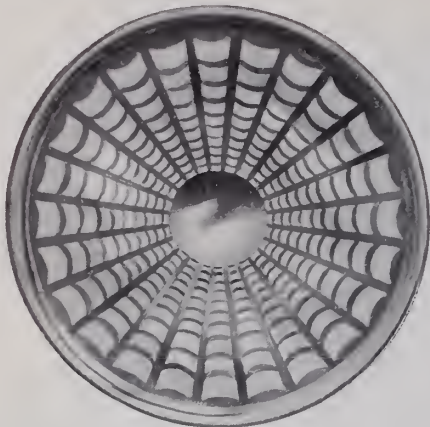

4844—4½", 5½", 6½", 7¼", 8½", 10", 12"

are one of the most popular articles in Sterling Silver this season for Easter and Wedding Gifts.



4747—7¼"

Sizes, 4 to 14 Inches

Prices - - \$3.00 to \$50.00 Each

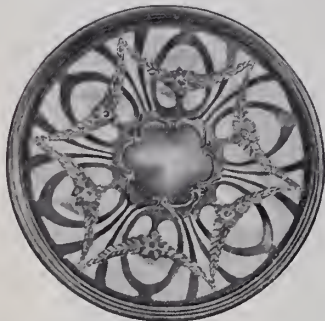

4734—4½", 5½", 6½", 7¼", 8½", 10", 12"



Frank M. Whiting & Co.

SILVERSMITHS

NORTH ATTLEBORO, MASS.

320 Fifth Avenue, New York

MEDALS AND AWARDS

FOR ATHLETIC CONTESTS

PRIZES TROPHIES SCHOLARSHIPS DEBATES ETC

THE PERGOLA

CHICAGO SWIMMING CLUB

CMR

BUTLER COLLEGE

MEDALS

THE CHAS. M. ROBBINS CO.
MANUFACTURING JEWELERS AT TLEBORO, MASS.



The Gillette Safety Razor Set consists of a triple silver-plated holder and twelve double edged, thin, flexible, wafer-like blades (24 keen edges), packed in a velvet lined leather case. Price, \$5.00. Also made in Combination Sets in a variety of styles with toilet accessories retailing from \$6.50 to \$50.00 each.

Would You Have the Present Year Bring You Increased Patronage, Profit and Prosperity?

Do you realize that nearly every hour in the day some man is converted to the easier, quicker and more economical way of shaving himself with the

Gillette Safety Razor?

Our persistent and vigorous advertising in the leading publications of this country discloses — *and will continue to disclose* — beyond all question of doubt, the superiority of the "Gillette." It advocates the advantages of self-shaving and guides the man to your store with a five dollar bill to exchange for the best shaving device in this world.

You can readily see the wisdom of having the "Gillette" ready when he calls. The Standard Gillette Set retails at \$5.00 everywhere. Combination Sets from \$6.50 to \$50.00. Keep a good supply in stock. Write to-day for valuable selling information and prices.

GILLETTE SALES CO., 904 Times Bldg., New York City



Scarf Pin 891
Old English
Set as ordered

Scarf Pin
842—Rose
or Green
Set as
ordered

Neck Chain 296
Old English Chain
Roman Scrolls
16" long
Stones set as ordered
Baroque Pearl
Pendant

Link Button
877—Rose, Ruby
and Brilliants
878—O. E., Ruby
and Brilliants

Link Button
872—O.E., Stones set
as ordered

Easter Suggestions

We have this season many choice designs in Fine Gold Filled Jewelry, suitable for Easter gifts, among which are Neck Chains and Pendants, Locketts and Charms, Link Buttons and Bracelets, as well as Brooch, Veil, Scarf and Hat Pins. Our Gold Filled Goods meet the most critical test for high standing.

We mention our Sterling Silver Toilet, Manicure and Table Goods as appropriate Wedding Gifts.



Charm 2982
Rose, Ruby Stones

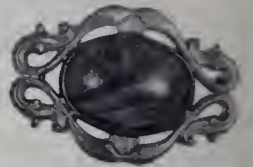

Brooch Pin
3864—Old English, Japanese
Jade Stone



Locket
3013—Rose, No Stones
3016—Rose, Red Eyes,
White Mouth



Scarf Pin
884 O.E.
Set as
ordered

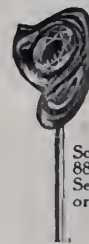

Scarf Pin
886—O.E.
Set as
ordered



Belt Buckle
3540²—Rose, Ruby Eyes, Stone in Mouth set as ordered, Pin Stem
3540 —Rose, Ruby Eyes, Stone in Mouth set as ordered, Clasp



Charm
2984—Rose, Red Eyes,
White Mouth
2983—Rose, No Stone

Theodore W. Foster & Bro. Co.

Manufacturing Jewelers and Silversmiths

100 RICHMOND ST., PROVIDENCE, R. I.

NEW YORK: 13 Maiden Lane

CHICAGO: Heyworth Bldg.

CANADA: Kingston, Ontario

THE JEWELERS' CIRCULAR

WITH WHICH ARE CONSOLIDATED
 THE HOROLOGICAL REVIEW
 THE JEWELERS' WEEKLY THE JEWELERS' REVIEW

VOL. LVI.

WEDNESDAY, APRIL 15, 1908.

No. 11.

Royal Cramp Rings.

AMONG the many styles of ancient rings none are mentioned these days less frequently than the royal "cramp rings" of former times. Hence few of us are aware they ever existed, though in their day they had a great vogue in Great Britain.

The Kings of England for several centuries had the custom of blessing or "halloving" certain rings. These rings had the supposed virtue of curing cramps and the "falling sickness" (epilepsy). Queen Mary was the last to bless these "cramp" rings;

led them to his cell, where he refreshed them and afforded them a night's shelter.

Before leaving him the next morning the aged recluse asked his guests to take a certain ring, which he gave to them, and carry it and present it to King Edward. He begged them to tell their pious sovereign that this ring was the one he had presented to the pilgrim years ago. They were asked to state that that pilgrim was no other than St. John, who had blessed the ring and given it great healing properties and now returned it to the royal donor.

It must be remembered that the disease

English kings and queens considered it one of their proud prerogatives to impart healing powers to rings by rubbing them between their hands with a certain Latin invocation.

An interesting recital of the ritual of the cramp ring dedication is found in a MS. of the "Orders of England's Household," 13th Henry VIII., 1522, preserved in the Imperial Library at Paris. It runs as follows:

First, the king to come to the chappell or shappell with the lords and noblemen wayting on him, without any sword to be borne before him on that day, and to tarry in his travers till the bishop and deane have brought forth the crucifix out of the vestry (the almoner reading the service of the cramp rings), layd upon a cushion before the high altar, and then the huishers shall lay a carpet before yt for ye king to creepe to the crosse upon; and yt done there shall be a fourme set upon the carpet before the crucifix, and a cushion laid before it for the king to kneel on; and the master of the jewell house shall be ther ready with the crampe rings in a hasin or basins of silver; the king shall kneel upon the sayd cushion before the fourme, and then must the clerke of the closett be ready with the booke conteyninge ye service of the halloving of the said rings, and the almoner must kneel upon the right hand of the king holding of the sayd booke, and when yt is done the king shall rise and go to the altar, where an huisher must be ready with a cushion to lay for his grace to kneele upon, and the greatest Lord or Lords being then present shall take the basin or basins with the rings and bear them after the king, and then deliver them to the king to offer; and this done the queen shall come down out of her closett or travers into the chappell with ladies and gentlewomen wayters on her, and creepe to the crosse; and that done she shall againe returne into her closett or travers, and then the ladies shall come downe and creepe to the crosse, and when they have done, the Lords and noblemen shall in likewise.



EDWARD THE CONFESSOR GIVING RING TO ST. JOHN.
 (FROM THE ABBREVIATED DOMESDAY BOOK.)

they were consecrated to their healing mission on Good Friday.

Edward the Confessor is said to have had the first of these cramp rings presented to him by St. John. King Edward—so the legend runs—on one of his rambles was accosted by a pilgrim who begged alms of him. A search for coin resulted in the discovery that he had not a coin of any description on his person. But the king, living up to his renown for charitable deeds, was not to be obstructed in his actions. Taking a ring from his finger, he presented it to the holy pilgrim fresh from his pious trip to the Holy Land. Now, this pleading pilgrim was no other than the Apostle St. John in disguise. Years after this event some tired and hungry pilgrims lost their way and the night was rapidly overtaking them in their sad plight when a venerable hermit appeared before them and

of epilepsy was known in those days also as *morbus Sancti Johannis* (disease of St. John).

In the abbreviated Domesday Book which dates early in the 13th century there is an illumination depicting Edward the Confessor in the act of presenting his ring to St. John, disguised as a pilgrim. A copy of this picture is displayed on this page in all its quaint style. Note especially the anklets worn over the naked feet of the holy man. With his pilgrim's staff and bottle and garbed in the regulation haircloth robe, the picture affords a good conception of those holy sojourners.

Presumably the swollen proportions of the regal ring are symbolic of its vast importance. It would easily pass over the royal fist as displayed in the drawing.

But to return to our subject, cramp rings. Starting from this event in ring history,

Lectern for King's Bible Presented by President Roosevelt to a Virginia Church.

AMONG the most notable productions in art bronze work recently in the public eye is the beautiful lectern presented by the President of the United States to the Bruton Parish Church, Williamsburg, Va., in which will rest the Bible presented by King Edward VII., of England.

The lectern, of which three views are shown on the front cover of this issue, has an artistic base resting on legs in scroll work effect. On the base is a shield on one side of which is the American eagle and on the other the British lion. Resting on the shield is a sphere, and standing on this sphere is an angel dressed in flowing garb and holding supported on her head the rest for the Bible.

On bronze plates at the base are the following inscriptions: "Presented by Theodore Roosevelt, President of the United States," "To the Glory of God" and "Commemorative of the three hundredth anniversary of the permanent establishment of English civilization in America, 1607-1907."

The lectern was designed by J. Stewart Barney, and was cast by the Gorham Co., Providence, R. I., and New York.

Amber and the Amber Industry.

By EMIL FREUND.

AMBER, though classed among minerals, is of vegetable origin, bearing evidence of having been in a fluid or viscid state. It is a hard yellow substance, rather heavier than water (its specific gravity being from 1.06 to 1.07), usually transparent when polished, but occasionally opaque or clouded. It has a resinous taste and a smell similar to that of turpentine. It is inflammable, and gives off, while burning, a white, pungent, aromatic smoke. It possesses electric properties, which are strongly developed by friction and which gave the name of the science of electricity, from *elektron*, the Greek word for amber.

At various times the origin of amber has been a matter of dispute among naturalists, some describing it as an animal substance resembling beeswax, secreted by an ant inhabiting pine forests; others maintaining it to be fossil mineral, of antediluvian origin; and others, again, with greater truth, imagining it to be a resin, oozing from the pine and afterwards solidifying. This idea was entertained by Pliny, who speaks of amber as a resinous juice, oozing from old pines and firs, and discharged by them into the sea.

According to the recent researches of Göppert, amber is nothing more than an indurated resin, derived from various trees of the family of the coniferæ, which resin is found in a like condition in all zones, because its usual original depositories, *viz.*, beds of brown coal, have been formed almost everywhere, under similar circumstances.

A convincing proof that amber was once a fluid is afforded by the fact that insects, leaves, drops of clear water, or portions of metal, sand, etc., are sometimes found enclosed in it. The insects are sometimes in a fine state of preservation, but frequently their detached legs and wings show that there was a hard struggle to escape from the viscid mass. Bees, wasps, gnats, spiders and beetles have been observed in specimens of amber; but the species more resemble insects of tropical countries than of the temperate zone. This curious circumstance of the inclosure of insects in amber has been taken advantage of by dishonest dealers, who imitate this substance in common copal, which closely resembles amber. Copal inclosing insects is often sold as the finest amber.

Amber is found in rounded masses, varying in size from that of a nut to a man's head; but the latter is very rare. It is chiefly obtained on seacoasts, after storms when it is either picked up on the beach or sought after by men who walk up to their necks in the waves, with long poles to which nets are attached; or it is gathered from precipitous cliffs by men in boats, who are armed with poles and iron hooks and loose fragments of rock in exploring them. The latter methods are not without danger to the amber seekers. The most abundant supply of amber is obtained in East Prussia, along the coast of the Baltic, between Memel and Dantzic, and especially on the shore near Königsberg, and from Grossschheim to Pillau. It has been found in Poland, Saxony, Siberia and Greenland and a Crowder in Norfolk and on the Yorkshire coast. Amber is also found in sand an

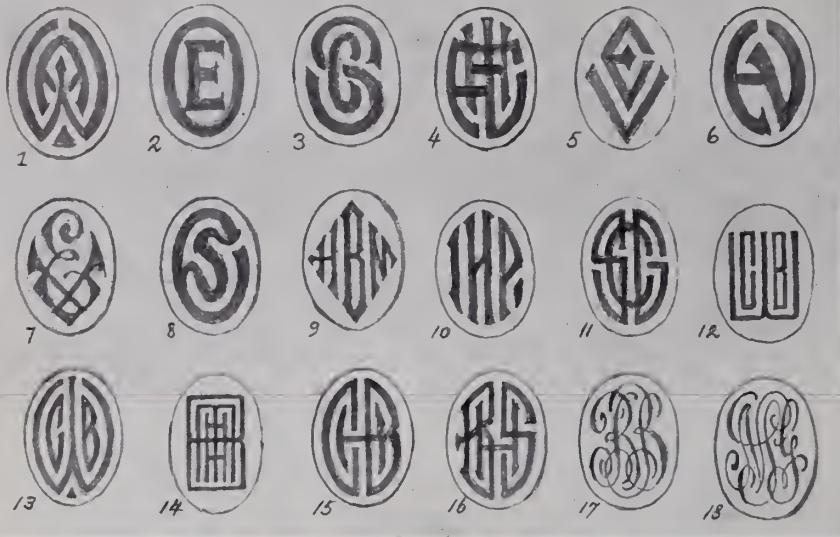

YOU may have a customer who has purchased a fine signet ring and desires to have his initials engraved on it with more character than just engraving them in the ordinary way, *i. e.* cutting the letters into the gold.

The above designs fill just such wants. We cut away the gold from the letters, leaving them in base relief, which adds materially to the appearance of the ring. Our price for two or three letter monograms is \$3.00 net; single letter, \$1.50 net; single letter on extra large plate, \$2.25 net.

LARTER & SONS

21-23 Maiden Lane, New York, N. Y.

TRADE-MARK



REGISTERED IN U. S. PATENT OFFICE

clay formations; and, although not often obtained by mining operations, yet pits are occasionally sunk in sandy downs to the depth of 100 feet and small quantities of amber thus procured.

Amber is used for ornamental purposes, but is much less esteemed in Europe than among the Oriental nations, where the demand for it is very great. It is fashioned into necklaces, earrings, beads, bracelets, crosses, etc.; also into snuff-boxes and more costly kinds of tobacco pipes. For these purposes the nodules are split on leaden plate at a turning lathe and brought into the required shape by whetstones, after which they are polished with chalk and water or a vegetable oil, and completed by rubbing with flannel.

The German pipemakers, who use great quantities of amber, burn a small lamp or a little pan of charcoal beneath the amber to warm it slightly while it runs on the lathe to prevent it from chipping out; they also succeed in bending it by means of heat.

The coarser sorts of amber and the small pieces which cannot be applied to ornamental purposes are used in making varnishes of a strong and durable kind, among which is the block varnish of coachmakers. The substance called artificial musk is nothing more than amber subjected to the action of nitric acid, which converts it into a viscid mass, having a musky odor.

Amber forms one of the most lucrative articles of commerce with Turkey, where the greater part of the European amber is sold; but considerable quantities are also purchased by American merchants. The value of amber increases greatly with the size of the specimens.

The kind of amber most esteemed is the opaque, which resembles the color of a lemon, and is sometimes called fat amber. The transparent pieces are very brittle and vitreous.

Exports of Jewelry, Clocks, Watches, Silverware and Kindred Lines from the Port of New York.

WASHINGTON, D. C., April 8, 1908.—The following were the exports of jewelry, silverware, optical goods, clocks, watches and kindred lines from the Port of New York for the week just ended:

Antwerp: 4 cases clocks, \$153.
 Barcelona: 3 cases optical machinery, \$352.
 Berlin: 2 cases clocks, \$391; 3 cases optical machinery, \$291.
 Bremen: 1 case plated ware, \$105; 3 cases watches, \$2,014; 2 cases jewelry, \$780.
 Calcutta: 4 cases watches, \$750; 3 cases plated ware, \$256; 10 cases clocks, \$200.
 Cape Town: 27 cases clocks, \$649; 1 case watches, \$129.
 Chemulpo: 17 cases clocks, \$495.
 Corinto: 1 case watches, \$517; 2 cases jewelry, \$1,050.
 Cooktown: 16 cases clocks, \$2,516.
 Cristobal: 1 case plated ware, \$172.
 Guadeloup: 2 cases plated ware, \$106.
 Guayaquil: 1 case jewelry, \$226.
 Hamburg: 7 cases optical goods, \$838; 25 cases clocks, \$1,350.
 Havana: 1 case jewelry, \$28,760.
 Havre: 2 cases jewelry, \$275.
 La Paz: 1 case jewelry, \$200.
 Liverpool: 2 cases silverware, \$527; 25 cases clocks, \$1,525; 2 cases jewelry, \$700; 2 cases silverware, \$885; 2 cases jewelry, \$308; 3 cases watches, \$450; 53 cases clocks, \$1,555; 16 cases clocks, \$462; 3 cases jewelry, \$534.
 London: 1 case plated ware, \$125; 14 cases optical goods, \$789; 2 cases plated ware, \$116; 2 cases thermometers, \$158.

Madras: 181 cases clocks, \$2,964.
 Melbourne: 39 cases plated ware, \$2,824; 9 cases optical goods, \$1,912; 91 cases clocks, \$1,500; 4 cases stereoscopes, \$916.
 Para: 1 case watches, \$108; 15 cases clocks, \$213; 330 cases clocks, \$6,630.
 Porto Alegre: 2 cases clocks, \$175; 1 case watches, \$146.
 Progreso: 13 cases clocks, \$271.
 Rio de Janeiro: 1 case watches, \$570.
 Southampton: 2 cases optical goods, \$1,078; 11 cases watches, \$1,894; 1 case jewelry, \$180; 7 cases clocks, \$2,533.
 St. Croix: 2 cases plated ware, \$138.
 Sheffield: 1 barrel jewelers' sweepings, \$12,000.
 Sydney: 6 cases clocks, \$131.
 Yokohama: 4 cases clocks, \$1,011.

Radiography in Pearl Fishing.

THE products of the sea are commonly wasted to a very deplorable degree by those who gather and use them. In no instance is this waste more marked than in the search for pearls. By the old method, which is still in vogue as a general rule, an enormous number of the so-called oysters are taken from their habitat and destroyed without any thought of economy. It is said that only one pearl is found in 100 oysters, and only one per cent. of the pearls found are of any commercial value. Thus some 10,000 of the precious mollusks are sacrificed for every useful pearl obtained. Among these victims there must be a vast amount of immature pearls or seeds, pearls *in posse*, which might grow and become valuable gems, which are deprived of that possibility by premature destruction.

In the year 1901 Prof. Raphaël Dubois took radiographs of pearls *in situ* within the shell of *Unio prolifera*, and obtained a clear view of their size and situation in spite of the thickness of the shell in which they were incased. He showed these radiographs at the Linnean Society of Lyons, and remarked that the X-rays might receive a novel application if used in the fisheries of Ceylon, and the destruction of a vast number of the prized mollusks might thus be avoided.

The difficulty of applying the X-rays to many thousands of shells *per diem* seemed sufficient to deter the ordinary person from such a laborious attempt. However, a few years later an electrical engineer of New York, John J. Solomon, who took an interest in the question of pearls, was struck by the same idea of using the X-rays to detect the existence of pearls within the shell of the living animal. He was then unaware of the earlier experiments of Prof. Dubois, but promptly set himself about the work from a commercial point of view.

In reviewing his work, *La Nature* states that he found that an exposure necessary to obtain a good picture did not in any way injure the animal, and even an exposure of 10 times as long could be applied harmlessly. The dangers lay rather in the removal of the bivalve from its normal attachment and in the time required for its transit from its bed to the laboratory of the photographer; for the pearl oyster is really a kind of mussel, which holds onto some fixed object by a brush of fibrils (*byssus*) growing from its body.

Thus the fundamental principle of Prof. Dubois, to save the life of unremunerative bivalves, bids fair to be carried out by American ingenuity and capital.

For practical purposes, where many thousands of shells have to be radiographed daily, a completely novel kind of plant had to be devised. This was done, and final success was considered to be well in view, when one hundred clear radiographs could be taken on an average every 15 seconds. Mr. Solomon often succeeded in taking as many as 500 per minute. In this process some hundred shells are exposed at a time to the rays. The oysters, spread on trays, are carried under the specially constructed cylinders by means of an electric motor. These great cylinders are cooled by means of suitable water jackets, and can thus be kept working continuously.

The oysters in which there is no sign of pearl formation are put back to their beds. Those in which good-sized pearls are detected are removed and opened, and the pearls promptly utilized. Those showing no pearls of adequate commercial value, but containing promising seed or immature pearls, are carefully placed in hospital. This hospital has rather a novel object; not the cure of the pearl disease (for the much prized gem is but a pathological growth), but, on the contrary, everything is done to keep the mollusk in *statu quo ante* so that the disease may progress as rapidly as possible to the production of valuable pearls and to the death of the incurable patient.

The question seems to arise, can the normal, or perhaps we should say, the abnormal, conditions of the pearl-producing bivalve be well enough imitated in captivity to insure the continued growth of the pearls? May not the "change of water" (as they must be kept nearer the surface) secure for the sufferers immunity from their diseased process? One might have imagined that a greater amount of sunlight, more oxygen, altered temperature, different nutrition, lessened pressure, and other changed conditions we think not of, would so influence the life of the mollusk that it might depart from its pathological but useful habit of producing these valued round bits of shell material, and the hospital might thus become a true *Kur-Anstalt* instead of a pearl-breeding depot. But Mr. Solomon tested these points, and he has satisfied himself that, if he can be certain to transmit in all circumstances the oysters to and from his laboratory without injury to their well-being, all other difficulties have already been overcome. As to the lucrative commercial value of the undertaking, time alone can tell; sufficient has not yet elapsed to make it demonstrable by actual proof that pearls can thus be hatched *en gros*.—*Scientific American*.

The South Bend Watch Co., South Bend, Ind., reports that the company has now on its books the names of 10,334 retail jewelers who are selling the watches of this concern. M. C. Winsor, Somerville, Mass., has taken on the company's lines for the New England States. Mr. Winsor is going to make the New England States his headquarters. He has just returned to Somerville after a trip to the South Bend factory. A. E. Dimock is another addition to the sales force and will take care of three of the southeastern States.

LOUIS KAHN

MOSES KAHN

SAMUEL H LEVY

L. & M. Kahn & Co.

Importers and Cutters of
DIAMONDS

170 Broadway, cor. Maiden Lane, New York

AMSTERDAM: 2 TULP STRAAT

CUTTING WORKS: 29 GOLD STREET

Arnstein Bros. & Co.

Importers and Cutters of

DIAMONDS

65 Nassau Street

New York

LONDON: Audrey House, Ely Place

AMSTERDAM: 6 Tulp Straat

ALBERT LORSCH

N. Y. Telephone Call, 2161-2 John

ALFRED KROWER

ALBERT LORSCH & CO.

LORSCH BUILDING, 37 and 39 MAIDEN LANE, NEW YORK

131 Washington Street, Providence, R. I.

Reconstructed Rubies

IN CABOCHON AND BRILLIANT CUT, ALL SIZES AND SHAPES

JEWELRY IMPORTS AND EXPORTS.

A Review of Our Commerce in Clocks, Watches, Jewelry, Gems and Kindred Lines as Shown by the Government's Statistics.

WASHINGTON, D. C., April 9.—In continuance of the article on the commerce of the jewelry trade of the United States for the fiscal year ending June 30, 1907, published in THE CIRCULAR-WEEKLY of Feb. 5, we find the following items of merchandise for immediate consumption and withdrawal from warehouse during the year:

Agates, unmanufactured, \$934; free.
Agates, manufactures of, not specially provided for, \$24,022.04; duty at 50 per cent., \$12,011.03.
Amber, manufactures of, \$9,021.75; duty at 25 per cent., \$2,255.44.
Albentine, albata or German silver, \$6,187; duty at 25 per cent., \$1,621.75.
Regalia, gems, statuary, free, \$339,005.80.
Works of art not intended for sale, free, \$1,636,049.
Works of art for public institutions, free, \$16,360.
Art works, not elsewhere specified, the production of American artists living abroad, \$708,865.50.
Beads, not threaded or strung, \$162,248.37; duty at 35 per cent., \$56,786.94.
Brazilian pebble, unmanufactured, \$7,967; free.
Chrysolite and manufactures of, \$3; duty at 50 per cent., \$1.50.
Chronometers, box or ship, and parts of, \$1,640; duty at 40 per cent., \$656.
Do., under treaty with Cuba, \$98; duty at 40 per cent., less 20 per cent., \$31.36; an actual duty of 32 per cent. ad valorem.
Clocks and parts of, not specially provided for, \$922,024.51; duty at 10 per cent., \$236,809.80.
Clock cases, with or without movements:
Composed wholly or in part of china, porcelain, parian, bisque or earthen ware, \$260; duty at 60 per cent., \$156.
Composed of marble, onyx, alabaster, etc., \$5,974.37; duty at 50 per cent., \$2,987.19.
Watch movements, cases and parts of watches:
Movements, having not more than 7 jewels, \$57,184 at \$731,331.60, or an average of \$5 3/10c. each; duty at 35c. each and 25 per cent., \$48,847.33, or 66.02 per cent.
Do., from the Philippines, 14 at \$17, or \$1.21 each; duty at 75 per cent. of 35c. each, and 25 per cent., \$6.87, or 40 41/100 per cent. ad valorem.
Do., from Cuba, 14 at \$32, or \$2.29 each; duty at 35c. each and 25 per cent., less 20 per cent., \$10.32, or an average ad valorem of 32.25 per cent.
Having more than 7 and not more than 11 jewels, 20,031 at \$58,782, or an average of \$2.93 each; duty at 50c. each and 25 per cent., \$24,711.01, or an average ad valorem duty of 42.04 per cent.
Do., from Cuba, \$9 for \$2; duty at 50c. each and 25 per cent., less 20 per cent., \$4.50 or 28.89 per cent. ad valorem.
Having more than 11 and not more than 15 jewels, 58,322 at a total value of \$192,393, or an average of \$3.29 each; duty at 75c. each and 25 per cent., \$91,989.75, or an average ad valorem rate of 47.81 per cent.
Having more than 15 and not more than 17 jewels, 18,600 at \$122,947, or an average price of \$6.61; duty at \$1.25 each and 25 per cent., \$3,986.75, or an average of 43.94 per cent.
Having more than 17 jewels, 6,113 at \$184,383, or an average value of \$30.16 each; duty at \$3 each and 25 per cent., \$64,434.75, or an average of 34.95 per cent.
Cases and parts of, including dials, \$84,006.21; duty at 40 per cent., \$33,760.49.
Do., from the Philippines, \$36; duty at 75 per cent. of 40 per cent., \$10.80, an average of 30 per cent.
Do., from Cuba, \$100; duty at 40 per cent., less 20 per cent., \$32, an average of 32 per cent.
Jewels, for use in the manufacture of watches and clocks, \$789,042.50; duty at 10 per cent., \$78,904.25.
This gives a total value of clocks, watches and parts of same, of \$3,523,076.19, on which the duty paid aggregated \$1,375,199.27, or an average ad valorem duty of 39 3/100 per cent.
Copper, \$1,510; free.

Coins, other, except those imported as money, \$17,214; free.
Medals of gold, silver or copper, and other trophies or prizes, \$2,232; free.
Diamonds and other precious stones:
Diamonds, rough or uncut, \$10,792,908; free.
Diamonds, miners', glaziers' and engravers', not set \$444,731; free.
Diamond dust or bort, \$209,668; free.
Other precious stones, uncut, \$156,327; free.
Advanced in condition or value from their natural state by cleaving, splitting, cutting or other process, and not set:
Diamonds, \$23,933,369; duty at 10 per cent., \$2,393,336.90.
Other precious stones, \$4,608,210.57; duty at 10 per cent., \$460,821.08.
Do., from the Philippines, \$360; duty 75 per cent. of 10 per cent., \$27, an average of 7 50/100 per cent.
Imitations of, composed of glass or paste, not exceeding an inch in dimensions, not engraved, painted or otherwise ornamented or decorated, and not mounted or set, \$784,401.81; duty at 20 per cent., \$156,880.38.
Pearls in their natural state, not set or strung, \$1,593,498; duty at 10 per cent., \$159,349.80.
From the Philippines, \$8; duty at 75 per cent. of 10 per cent., 60c., or 7 50/100 per cent. ad valorem.
This makes a total importation of diamonds and precious stones, free of duty, of \$11,503,634, and of those subject to duty, of \$30,919,847.38, on which the duty paid was \$3,107,415.76, or an average ad valorem of 10.25 per cent. This makes a grand total for dutiable and free of \$42,423,481.38, all for home consumption.
White glass enamel, for watch and clock dials, \$13,866; free.
Glass plates or disks, rough cut or unwrought, for use in the manufacture of optical instruments, spectacles and eyeglasses, and suitable only for such uses, \$218,534; free.
Lenses, with edges unground, 35,876 dozen pairs at \$12,657.50, an average of .353 per dozen; duty at 45 per cent., \$5,695.88.
Lenses, with edges ground or beveled, 1,125 dozen pairs at \$11.954, or an average of \$10.62 per dozen; duty at 10c. per dozen pairs and 45 per cent., \$5,491.82, or an average ad valorem of 45.94 per cent.
Opera and field glasses, telescopes, microscopes, photographic and projecting lenses and optical instruments, and frames or mountings for same, not specially provided for, \$457,224.77; duty at 45 per cent., \$205,751.15.
Do., from the Philippines, \$3; duty at 75 per cent. of 45 per cent., \$1.01, or 33 75/100 per cent.
Do., from Cuba, \$70; duty at 45 per cent., less 20 per cent., \$25.20, an average of 36 per cent.
Spectacles, eyeglasses and goggles, also frames for same, or parts thereof, finished or unfinished:
Valued at not over 40c. per dozen; 15,715 dozen at \$3,843, an average of 24 4/10c. per dozen; duty at 20c. per dozen and 15 per cent., \$3,719.43, or an average ad valorem of 96.81 per cent.
Valued at over 40c. and not over \$1.50 per dozen; 3,738 3/4 dozens at \$3,479, an average of 93c. per dozen; duty at 45c. per dozen and 20 per cent., \$2,378.25, or an average of 68.36 per cent.
Valued at over \$1.50 per dozen; 23,000 dozen at \$70,549.75, or an average of \$3.07 per dozen; duty at 50 per cent., \$35,274.88.
Glass slides for magic lanterns, \$10,461.96; duty at 45 per cent., \$4,707.88.
Gold pens, \$114.08; duty at 25 per cent., \$28.52.
From Cuba, \$26; duty at 25 per cent., less 20 per cent., \$520, or 20 per cent. ad valorem.
Gold manufactures not specially provided for, \$19,566.80; duty at 45 per cent., \$8,805.07.
Silver, manufactures of, not specially provided for, \$145,700.75; duty at 45 per cent., \$65,565.37.
Do., from Philippines, \$8; duty at 75 per cent. of 45 per cent., \$2.72, or 33 75/100 per cent. ad valorem.
Do., from Cuba, \$2; duty at 45 per cent., less

20 per cent., 72c., or 36 per cent. ad valorem.
Gold and silver sweepings, \$115,109; free.
Goldbeaters' molds and skins, \$32,929; free.
Knives, pen, pocket, eraser, manicure, valued at more than \$1.25, and not exceeding \$3 per dozen, 1,237,452 at \$242,636.47, or an average of 19 6/10c. each; duty at 10c. each and 40 per cent., \$220,799.79, or an average ad valorem duty of 91 per cent.
From the Philippines, 12 at \$2, or 16 7/10c. each; duty, 75 per cent. of 10c. and 40 per cent., \$1.50, or an average of 75 per cent. ad valorem.
Valued at more than \$3 per dozen, 346,793 at \$157,051.62, or an average of 45 3/10c. each; duty at 20c. each and 40 per cent., \$132,179.25, or an average of 84 16/100 per cent. ad valorem.
Swords, sword blades and side arms, \$33,358.75; duty at 35 per cent., \$11,675.56.
From the Philippines, \$26; duty at 75 per cent. of 35 per cent., \$6.85, or 26 25/100 per cent. ad valorem. Table and other knives and forks and steels, with handles of mother-of-pearl, shell or ivory, 12,562 at \$4,740, or an average of 37 7/10c. each; duty at 16c. each and 15 per cent., \$2,720.92, or an average of 57 40/100 per cent. ad valorem.
With handles of deer horn, 31,277 at \$7,863, or 25 1/10c. each; duty at 12c. each and 15 per cent., \$4,932.69, or an average of 62 73/100 per cent.
Butcher, hunting, artists' and other knives:
With handles of mother-of-pearl, shell or ivory, 160 at \$69, or 43 1/10c. each; duty at 16c. each and 15 per cent., \$35.95, or 52 10/100 per cent. ad valorem.
With handles of deer horn, 72 at \$11, or 15 3/10c. each; duty at 12c. and 15 per cent., \$10.29, or 93 55/100 per cent. ad valorem.
Ivory tusks, cut vertically across the grain only, with the bark left intact, 646,900 pounds at \$2,005,474, or an average of \$3.10 per pound; free.
Vegetable ivory, 16,619,075 pounds at \$467,100, or 2 8/10c. per pound; free.
Manufactures of ivory, \$68,587.24; duty at 35 per cent., \$24,005.54.
Do., from the Philippines, \$24.50; duty at 75 per cent. of 35 per cent., \$6.46, or 26.37 per cent. ad valorem.
Jet, unmanufactured, \$26; free.
Jet, manufactures of, not specially provided for, \$4,756.50; duty at 50 per cent., \$2,378.25.
Jewelry and parts thereof, finished or unfinished, not specially provided for, including precious stones, set; pearls, set or strung, and cameos in frames, \$1,087,961.06; duty at 60 per cent., \$652,776.65.
From the Philippines, \$273.50; duty at 75 per cent. of 60 per cent., \$123.08, or 45 per cent.
From Cuba, \$374; duty at 60 per cent., less 20 per cent., \$179.52, or an average of 48 per cent.
Onyx, manufactures of, \$2,633.70; duty at 50 per cent., \$1,316.86.
Alabaster, manufactures of, \$11,137; duty at 50 per cent., \$5,568.50.
Shell and mother-of-pearl, manufactures, \$124,888.91; duty at 35 per cent., \$43,711.13.
From the Philippines, \$11; duty at 75 per cent. of 35 per cent., \$2.89, or 26 27/100 per cent.
From Cuba, \$43; duty at 35 per cent., less 20 per cent., \$12.04, or 28 per cent. ad valorem.
Shells, not sawed, cut, polished or otherwise manufactured:
Mother-of-pearl, \$1,085,325; free.
All other, \$404,288.53; free.
Engraved, cut, ornamented or otherwise manufactured, \$17,285; duty at 35 per cent., \$6,049.75.
From the Philippines, \$7; duty at 75 per cent. of 35 per cent., \$1.84, an average of 26.29 per cent.
From Cuba, \$3; duty at 35 per cent., less 20 per cent., 84c., or 28 per cent. ad valorem.
Spar manufactures, \$1,399; duty at 50 per cent., \$699.50.
During the year drawback was paid on clocks and watches to the value of \$1,372.45; on diamonds and other precious stones, \$16,129.96; during the year the exports of clocks and watches entitled to drawback were 634,050 and the drawback, \$8,193.19.

(To be continued.)

EDUARD VAN DAM

CUTTER OF

DIAMONDS

— CUTTING SHOPS: —

ANTWERP

41 Rue de la Province (Sud.)

CABLE ADDRESS, MADNAV

NEW YORK

437-439 Fifth Ave.
Cor. 39th St. Knabe Bldg.

TELEPHONE, 5879 38TH ST.
CABLE ADDRESS, DEVRIVAN

AMSTERDAM

55 Ruysdaelstraat

CABLE ADDRESS, MADNAV

LONDON OFFICE, 22 Holborn Viaduct

AMSTERDAM
2 Tulpstraat

LONDON
40 Holborn Viaduct

OPPENHEIMER BROS. & VEITH.

CUTTERS OF DIAMONDS.

Cutting Works
43-45-47 John Street

NEW YORK
65 Nassau Street

R., L. & M. FRIEDLANDER

IMPORTERS OF

DIAMONDS

30 MAIDEN LANE, - - - NEW YORK CITY

TURQUOISE

Matrix-Turquoise
BEST THE WORLD PRODUCES

**Exquisite Color
and Markings**



No. 222

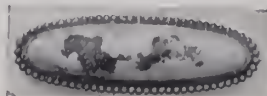

No. 316

SEND FOR CATALOG

Showing 133 different sizes and shapes
of **MATRIX-TURQUOISE STONES**
ready for Mounting.

**The Arizona
Turquoise Mines Co. Inc.**

Cutting Works and Sales Office:

171 BROADWAY, NEW YORK
Telephone 5728 Cortlandt

Man Who Borrows Money on Flashy Jewelry Finds That the Circular-Weekly Is Read in Texas.

EL PASO, Tex., April 8.—That THE CIRCULAR-WEEKLY is read in El Paso as thoroughly as in other parts of the country was made manifest this week, when a short, stout man, accompanied by a tall and stately looking woman, attempted to borrow \$900 on a quantity of jewelry from a local jeweler. This led eventually to the man having an interview with Chief of Detectives Billy Smith, and later leaving town with his companion without negotiating the loan.

Thursday afternoon last a man called at the store of the W. T. Hixson Co. and exhibited some diamonds set in clusters, explaining that he wanted to borrow \$900 on the jewelry, and saying that he would pay the highest interest if the jeweler would advance the money. He claimed that he was negotiating a deal in stocks, and wanted to raise the money quickly.

The manager of the store remembered reading in THE CIRCULAR-WEEKLY in the issue of March 25 a note about the Hebrew couple, who had been borrowing money from jewelers in Iowa and Nebraska, leaving very showy jewelry as security, and therefore decided to consult the article again before closing the deal, so he told the man to call again on the following day.

THE CIRCULAR-WEEKLY article was then consulted and turned over to a local paper and to the Chief of Detectives, and the latter wired to THE CIRCULAR-WEEKLY for further information. FROM THE CIRCULAR-WEEKLY Chief Smith received word that a Hebrew couple, believed to be those formerly in the west, had visited Austin, Tex., and telegrams to that city by Chief Smith brought back the information that the couple had borrowed \$900 on jewelry from a local bank for 60 days, and when the jewelry had been examined again it was found to be worth less than it was originally thought to be.

When the man came back to Hixson's he was given a check for \$900 for his diamonds and the jewels were sealed up. In the meantime payment on the check was stopped and the borrower was called to the office of the Chief of Detectives for an explanation. To the latter he explained he was a cigar dealer of Atlanta, Ga., and also engaged in selling diamonds, and in the latter he claimed he was connected with the house of Schaul & May. In answer to Chief Smith's questions he admitted he had borrowed money on diamonds in Austin, and had also done it in other places, but explained that he had violated no laws as the diamonds were in each case worth the \$900 which he had received, and even if they were not redeemed he simply sold them for this amount. In fact, he said, if any law was violated it was by those who had taken this security for a loan, unless they were licensed pawnbrokers.

When Chief Smith explained to the man that a story had appeared in THE CIRCULAR-WEEKLY telling of the operations in Iowa and Nebraska of a man who answered his description, the man was very much interested, and said: "If there is anything in THE CIRCULAR-WEEKLY reflecting on me or my wife, I will quit the business."

He told the Chief that he would come

back in the afternoon to see the extracts from THE CIRCULAR-WEEKLY in question, but when the time arrived for him to come back he did not appear, and Monday night the man and his wife took a Santa Fe train out of this city.

Before leaving town this man called at the jewelry store and gave back the check on which payment had been stopped, and got back his package of diamonds.

ATLANTA, Ga., April 10.—When inquiry was made of Schaul & May about the man mentioned in the above dispatch from El Paso, members of this firm stated they did not know anyone of the name he gave to the El Paso police, and that there was no one of that name connected with the concern in any way.

The Career of the Late A. G. Wiseman.

HARRDSBURG, Ky., April 8.—The death of A. G. Wiseman, last week, was a distinct shock to his many friends in the jewelry trade and in business circles generally, as few knew that he had been seriously ill when the news came that he had passed away. Mr. Wiseman, who had long been a leading jeweler and optician of this town, was taken suddenly ill with pneumonia on the evening prior to his death, and grew rapidly worse to the end.

Deceased, who was 75 years old, was a native of Germany, in which country he learned the jewelry trade. After coming to the United States he was for a while in business at St. Louis, and came from that city to Harrodsburg in 1896. Here he succeeded to the business of A. P. Wilson, which he conducted alone quite successfully, and from that time, and by his ability, integrity and high standard of commercial honor he made many strong friends in the community, and was considered one of the leading citizens of this section.

Mr. Wiseman is survived by a widow and three sons, Arthur Wiseman, of Shelbyville, Ind.; Edmond Wiseman, of Harrodsburg, and Eugene Wiseman, of Buffalo, N. Y.

Julius J. Jenkins, Baltimore, Md., Files Voluntary Petition in Bankruptcy.

BALTIMORE, Md., April 8.—Julius J. Jenkins, manufacturer and jobber of jewelry, 18 and 20 Baltimore St., was adjudicated a bankrupt, Monday, upon a petition filed by him through William G. Towers and William T. Larkin, attorneys. The petition states that his liabilities are \$5,532 and assets \$5,993. Of the liabilities \$4,416 is unsecured and is divided among 22 creditors.

Included in the assets are stock in trade valued at \$3,000 and open accounts of \$2,239. Pending the selection of a trustee William T. Larkin was appointed receiver under bond for \$5,000.

Mr. Jenkins was formerly in the employ of F. A. Gruebel for about four years, in addition to which he carried on a small business of his own with curbstone dealers. In 1902 he opened a store at 101 W. Fayette St., where he continued business until the fire of 1904. At that time he saved his stock, the value of which he estimated at about \$8,000. The damage which he sustained, he declared, was fully covered by insurance.

After the fire Mr. Jenkins moved to 318

W. Lexington St., and remained there until November, 1905, when he moved into his present quarters. He has always been considered an able jeweler and an enterprising business man.

Death of Phillip Woodman, Treasurer of the British Watch and Clock Makers' Asylum.

LONDON, April 4.—There is distinct sorrow in the watch trade here, owing to the death, March 30, of Phillip Woodman, who for over 30 years had been the treasurer of the Watch and Clock Makers' Asylum, an institution which is nearing the centenary of its foundation. Mr. Woodman's funeral, which occurred to-day, was attended by a large number of prominent men of the jewelry and kindred trades, including the editors of the leading jewelry journals and officials of the various societies.

Mr. Woodman was one of the old-fashioned Clerkenwell hand-made watch case manufacturers, and had always taken a deep interest in his trade. He took an especial interest in the aged people in the watch industry, and his work for the Watch and Clock Makers' Asylum endeared him to the hearts of all members of that trade. It is remarkable that, considering the condition of the watch trade, he nevertheless managed just before his death to accomplish the wish of his life, namely, to increase the endowment fund of the asylum from £5,000 (\$25,000) to £10,000 (\$50,000).

Deceased is survived by a sister, a patroness of the Watch and Clock Makers' Asylum.

Order of Ku-Kus to be Instituted at Piqua, O., April 23.

PIQUA, O., April 8.—Retail jewelers of this section are looking forward with much enjoyment and amusement to the establishment of a new Noble Order of Ku-Kus, of which mention was made in THE CIRCULAR-WEEKLY a short time ago. This fraternity, which was founded by A. L. Thoma, of A. Thoma & Sons, is essentially one to create amusement, and the membership is limited exclusively to jewelers and opticians and men connected with that trade and allied interests.

Lodge No. 1 will be officially instituted in this city at a meeting to be held April 23, at the Hotel Plaza. At this meeting a number of surprises will be sprung upon the charter members, which it is hoped will be enjoyed by all at the banquet which will be held. Speeches will be made by J. R. Stebbins, president of the Ohio Retail Jewelers' Association; F. P. Baugh, president of the Ohio Optical Association; O. C. Lightner, secretary of the Ohio Retail Jewelers' Association; John C. Eberhardt, Dayton, O., and many other lights in the jewelry and optical trade. The Mayor of Piqua and the jewelers and opticians of this place have officially offered a welcome to those who will participate.

W. A. Nelson, Watertown, S. Dak., has sold his stock and will move to the coast.

Herman Stenseth, trustee for Harry R. Jones, bankrupt, Devil's Lake, N. Dak., will sell the entire stock of jewelry in 10 lots to the highest bidder at 2 p. m. today.

Cameos=Scarabs=Carbuncles

Notwithstanding the difficulty generally experienced at present in supplying the sudden demand for these goods, we have succeeded, thanks to our firmly established connections with the stone centers of Europe, in making arrangements for the uninterrupted supply of them and are, therefore, fully prepared to fill all orders for these articles with the least delay.

CAMEOS

Onyx, Pink and Brown Shell, and Coral

SCARABS and CARBUNCLES

Red and Brown Sard, Bloodstone, Moss Agate, Green Agate, New Zealand and Chinese Jade, Amazonite, Tiger Eye, Coral-Japanese and Italian, and

TURQUOISE MATRIX

L. Heller & Son

Importers of Precious and Imitation Stones
68 NASSAU STREET, NEW YORK

PARIS
39 Rue de Chateaudun

PROVIDENCE
212 Union Street

IDAR
14 Hauptstrasse

ORDER

DIAMONDS

ON MEMORANDUM FROM

ALFRED H. SMITH & CO.

London,
6 Holborn Viaduct.

170 BROADWAY, NEW YORK.
Corner Maiden Lane.
Also 475 FIFTH AVENUE.

Chicago,
103 State Street.

"There is Nothing in the Art that we cannot do."

Special Attention

GIVEN TO OUT OF TOWN ORDERS

The International Gem Co., Inc.

12-16 JOHN ST., NEW YORK

TELEPHONE 1241 GORTLAND

Lapidaries and Importers of Precious Stones

SPECIALISTS IN REPAIRING AND REPOLISHING RARE AND VALUABLE GEMS
DRILLING—ENGRAVING—SLITTING



Charles Wagenführ,
Die Sinker,
140 West Broadway,
New York.

PATENTS

obtained on inventions and designs. Trade-marks, prints and labels registered.

R. W. BISHOP,
ATTORNEY-AT-LAW,

908 G Street N.W., Washington, D.C.

RUDOLPH NOEL

PHILIP NOEL

RUDOLPH NOEL & CO.

IMPORTERS AND CUTTERS OF DIAMONDS

2 Tulp Straat, AMSTERDAM

37-39 Maiden Lane, NEW YORK

Illinois Retail Jewelers Meet at Chicago and Form a New State Organization.

Chicago, April 11.—Mack A. Hurlbut, Ft. Dodge, Ia., and Ira M. Radabaugh, Hastings, Minn., respectively president and secretary of the American National Retail Jewelers' Association, came to Chicago last Thursday, April 9, for the purpose of organizing the retail jewelers of the State of Illinois. The meeting was held at the Great Northern Hotel at 2 p. m. on that day. The following retail jewelers responded to the call for organization: Geo. B. Elbe, Ben G. Burgbacher, S. Davis, W. G. Werner, J. M. Prockter, P. A. Peterson, Paul N. Lackritz, F. Rominski, Paul Forrester, R. Newman, H. C. Kracker, John J. Pfordrescher, Herman Zeitz, Fred Zeitz, R. G. Bolich, G. H. Tucker, M. Iglowitz, Louis Ritter, Chicago; O. B. Rystrom, of the Bauer Jewelry Co., Elgin; Arthur Roelstad, Elgin; H. G. Weger, West Chicago; H. I. Thompson, Buda; W. O. Foley, Chicago Heights; A. F. Pierce, Milford; Lorenz Holland, Cullom; Frank Smith, Pontiac; W. A. Hammond, Bement; Geo. L. Lewis, West Pullman; Otto Loven, Oak Park, and F. A. Marean, Belvidere.

President Hurlbut called the meeting to order, and in his address of welcome said the great State of Illinois was in need of organization. F. G. Tharle, president of the Chicago Jewelers' Association, welcomed the visitors in the name of the association, and said that organization could accomplish much needed reform if properly carried out. He said that the jobbers of Chicago appreciated the presence there of out-of-town jewelers, because of late the latter were a scarce article. He said these matters could be taken over at organization meetings, which were bound to benefit the whole trade, and concluded by inviting all present to a smoker which was held in the evening.

G. P. Engelhard then spoke on jewels and jewelers, and said that whoever butchered a watch committed a crime. He exhorted those present to strike for the highest ideals only.

Mack A. Hurlbut spoke on the benefits of organization, and said that one of the main objects of organization was to raise the jeweler to a higher plane. He said the retail jeweler was not the only man afflicted with trade troubles, but said the manufacturer and the jobber had their trade problems to solve also. He said the evils of the retail jewelry trade were the result of evolution, that many evils crept in gradually, until at present some of the abuses were unbearable. Organization, he said, could accomplish much to ameliorate the present condition of the trade. He claimed the jobber was a potent factor in the trade, because he economically distributed the products of many factories, and that many jobbers had started retail jewelers in business. He contended that trade abuses could be rectified by cool, clear, calm and reasonable talk with either manufacturer or jobber, and thought that if both the manufacturers and the jobbers were organized it would conduce to a speedy rectification

of trade abuses, because then the retail jewelers' association could treat with them as a whole, instead of doing it individually, as they do now.

Secretary Radabaugh then formally organized the new association, which is now known as the Illinois Retail Jewelers' Association. The constitution of the Minnesota association was adopted, the dues fixed at \$3 annually, and an affiliation with the National Association was effected.

A committee on nominations was then appointed, and at the request of President Hurlbut, Herman Stern, of THE CIRCULAR-WEEKLY, was requested to act in an advisory capacity. While the committee was out, Joseph Gilbert, president of the National Anti-Retail Mail Order League, delivered an interesting address on the "Mail Order Problem and How to Correct It," which is published in full on page 10 of this issue of THE CIRCULAR-WEEKLY.

The committee on nominations then reported their names, and the following officers were elected: President, Fred A. Marean, Belvidere; first vice-president, Frank Smith, Pontiac; second vice-president, Lorenz Holland, Cullom; secretary, Geo. Elbe, Chicago; treasurer, Paul N. Lackritz, Chicago; board of directors, one year, A. F. Pierce, Milford; two years, W. A. Hammond, Bement; three years, Otto E. Loven, Oak Park.

The association then indorsed the Vreedland Watch Case Stamping bill and adjourned until 8 p. m., when a vaudeville entertainment was provided for them at the Chicago Automobile Club smoker.

New Members Elected by the Jewelers Security Alliance.

The regular monthly meeting of the executive committee of the Jewelers Security Alliance was held on Friday, the following members being present: Chairman Butts, President Sloan, Vice-Presidents Champenois, Treasurer Karsch, Secretary Noyes, Messrs. Abbott, Alford, Bowden and Stern. The following new members were admitted:

H. F. Beaudry, Rockland, Mass.; Carrington & Co., Newark, N. J.; H. G. Frey, Vallejo, Cal.; Stephen R. Hoffman, Brooklyn, N. Y.; C. L. Rexford, Spartansburg, Pa.; George W. Shiebler, New York; Sprague Brothers, Ada, Okla.; A. & S. Esposito Co., New York; R. J. Atwell, Middletown, Conn.; W. H. & W. S. Bristol, Vergennes, Vt.; F. M. Grow & Co., Rutland, Vt.; Gustafson & Hendrickson, Omaha, Neb.; George M. Hascall, Rutland, Vt.; Orton Jewelry Co., Muskogee, Okla.; Blom & Zwaaf, Brooklyn, N. Y.; Hibbard Jewelry Co., Akron, O.; H. B. Holmes, Winchester, N. H.; Castagnetto & Matteucci, San Francisco, Cal.; W. H. Bishop, Ely, Nev.; John Burri, Wellsville, O.; M. E. Colvin, Lyons, N. Y.; H. Garman & Son, Coatesville, Pa.; Lowengardt & Armstrong, New Orleans, La.; Varney Jewelry Co., Wichita, Kans.; S. E. Howard, Hastings, Neb.; Jacques A. Halmans, Brooklyn, N. Y.; Karl M. Keyes, Warren, Ill.; I. M. Kinner, Hornell, N. Y.; R. Fechtner & Son, Chehalis, Wash.; M. J. Schoenfeld Co., Oakland, Cal.; Ben. F. Haller, Holdrege, Neb.; Henry Yoste Co., Vicksburg, Miss.; Goldfield Jewelry and Drug Co., Goldfield, Nev.; Thomas Canty, Watsonville, Cal.; Joseph's Loan Office, Houston, Tex.

Progress Being Made in the Formation of a National Association of Wholesale Jewelers.

DETROIT, Mich., April 11.—The formation of a national association of jewelry wholesalers and jobbers, proposed last November by the Detroit Jewelers' Board of Trade, now seems a certainty. Action was deferred then until Spring on account of the holiday trade and subsequent conditions in business.

Responses to the letters that were sent out recently by Secretary Charles A. Berkey have been so many and so enthusiastic that the Detroit board decided at its monthly meeting last Friday evening in the Griswold House, to proceed with the plans for a permanent organization. With the unanimous and hearty spirit of interest shown in the trade, it is felt that there is no chance of failure to carry the enterprise to completion.

A committee will work on the outline for an organization, and when the time seems ripe, a convention will probably be called during the Summer months. Previous to that time, it is hoped that a number of State and city organizations, in addition to those already in the field, will be organized and be represented so that the association may start off as a truly representative and country-wide organization.

Replics are coming in from all parts of the country and the general sentiment expressed is that the proper way to better trade conditions and banish abuses and evils which have a tendency to creep in is by co-operation, and that the time has come for such a movement to be carried through.

Below are excerpts from letters received from organizations and prominent wholesale firms in various portions of the country.

A leading jobbing house in the far southwest writes:

We would like very much to see the national organization realized and would be glad to become members of the same, for we realize that great good for the jobbers may be accomplished. We have talked to a great many jobbers over the country and all seem anxious for something of this kind. We believe that, if someone will take the initiative, a national organization may easily be perfected.

A member of a Pacific coast organization says:

It affords us great pleasure to hear from you on the lines suggested in our letter. It is the right and only step possible for the advancement of the jewelry trade, both wholesale and retail.

The response from a strong State organization in the middle west was as follows:

We have been working along just such lines as you map out in your letter. We are willing to assist you and will join the national association.

From an organization in an Ohio city:

We have recently formed a jobbers' association with the same objects and aims as your own. We also realize that, in order to accomplish the objects desired and to correct a great many existing abuses that have crept into the trade within the last few years, it would require the co-operation of all jobbers' associations in the various cities and we have no doubt but that this matter will be taken up by our association in a short time.

Several responses from northwestern cities also contained words of encouragement and approval.

Thieves recently attempted to rob the jewelry store of Mr. Heim, Sunbury, Pa., but were frightened off without securing an entrance.



RINGS



RINGS are always in demand, and are always salable, provided you have the right kind to sell. We have—
RINGS of every description: signet rings, diamond rings, fancy rings, rings of every style and combination of stones.
RINGS that satisfy the most critical and appeal to every taste and fancy.
RINGS You can sell. ☐ Write us or wire us any time. ☐ We are always ready for your order.

HAYDEN W. WHEELER & CO., Importers

AMSTERDAM, 2 Tulp Straat
 2 Maiden Lane, NEW YORK, N. Y.
 Phone, 7365 Cortlandt
 LONDON, 50 Holborn Viaduct

F. A. JEANNE

Seal Sapphires

5 Square de l'Opera

PARIS, FRANCE

Cable Address

"GEMFINDER"

Western Union Code



Chicago Art Metal Works

Manufacturers of

INITIALS and MONOGRAMS

FOR PURSES, BAGS, BRUSHES, ETC.

Monogram Fobs and Belt Buckles

Write for Catalogue and Prices

63 Lake St., Chicago, Ill.

STERN BROS. & CO.,

CUTTERS OF

DIAMONDS,

CUTTING WORKS:

138-142 West 14th St., N. Y.

68 Nassau St.,

NEW YORK.

CHICAGO,
103 State Street.

LONDON,
29 Ely Place.

Cable Address: "LEOGOLDIE" N. Y.

Telephone, 4115 Cortlandt
Amsterdam, 2 Tulp St.
Paris, 27 Rue Drouot.

LEO. GOLDSMITH

IMPORTER OF

Diamonds and Precious Stones

9, 11 & 13 Maiden Lane, N. Y.

Diamonds, Rubies, Sapphires, Emeralds,
Opals, Olivines, Pearls, Half-Pearls, Tur-
quoises, Reconstructed Rubies, Recon-
structed Sapphires.

ARREAUD & GRISER

68 & 70 Nassau St., New York

LAPIDARIES. PRECIOUS STONES

EMS in Unique Cuttings

CROSSMAN COMPANY

BAROQUE PEARL BAR PINS

3 Maiden Lane, New York

GEMS AND PRECIOUS STONES

Cloth, Postpaid, \$1.00

Published by

The Jewelers' Circular Pub. Co., 11 John St., N. Y.

Business Suspended and Schools Closed in Attleboro During Funeral of the Late Chas. E. Bliss.

ATTLEBORO, Mass., April 8.—Jewelry factories closed their doors, the stores suspended business, the public schools were closed, and Attleboro as an entire community devoted one afternoon to mourning this week, the occasion being the funeral of Charles E. Bliss, late of Bliss Bros., who passed away in Florida, and whose body was brought home to be laid at rest in the town to whose service he had given so many unselfish years. The unanimity of the mourning tribute was unusual for any man to receive. As a brother jeweler the trade did him honor; as a long time member of the school board these places of learning gave up their sessions; as a public officer in other lines his memory was honored by the town displaying flags at half staff from every public building; while as a private citizen his popularity was displayed by the fact that the Second Congregational church, his spiritual home for years, was unable to accommodate the hundreds who sought to join the family circle of mourners.

The remains lay in the front of the auditorium surrounded by scores of fragrant floral tributes. Rev. Dr. J. Lee Mitchell, pastor and long time personal friend, voiced an eloquent eulogy, and favorite music was rendered.

After the service the body was escorted to the family burial lot where Ezekiel Bates lodge, A. F. & A. M., of which he was past worshipful master, conducted its commitment ceremony. The bearers included Ernest D. Gilmore, of E. D. Gilmore & Co.; Mark E. Rowe; Edgar A. Remington, of Carter, Qvarnstrom & Remington; Arthur B. Carpenter; F. E. Cobb; Martin L. Chapman, formerly of Chapman & Barden; Alfred R. Crosby, of Smith & Crosby; Orville P. Richardson; Harry P. Kent, of F. W. Weaver & Co.; Albert S. Ingraham, of A. S. Ingraham & Co., and Benjamin P. King. The ushers at the church included William L. King, of E. D. Gilmore & Co.; Jesse Carpenter, of the Horton-Angell Co.; Raymond M. Horton, of W. E. Richards & Co., and Dr. G. E. McPherson.

The selectmen and the Second Congregational church have adopted eulogistic resolutions, and other bodies are arranging to do so.

Detroit Jewelers Plan to Participate in Buyers' Excursion Next August.

DETROIT, Mich., April 11.—There were two meetings of the Detroit Jewelers' Board of Trade, last week. Besides the regular monthly meeting, the board members met with committees of the Wholesalers' Association and the Hardware Dealers and adopted plans for a Buyers' Excursion next August. The dates chosen are from Aug. 10 to Aug. 15.

Three days of this time will be given to a programme of entertainment, including a dinner, lake rides and other features that will tend to assure the outside merchants of a pleasant time. Considerable money will be spent on the amusement features.

Victor C. Morse, president of the Michigan Retail Jewelers' Association, was pres-

ent and stated that he would favor changing the dates for the annual meeting of that organization so that it might be held in Detroit at that time. He will take up the matter with the officers of his organization and with those of the State optical association.

At the regular meeting of the board Friday-evening, the plan for establishing a trade school was discussed in detail and the members expressed themselves as in favor of it. It is figured that not only watchmaking and the jewelry trade may be taught, but also storekeeping, and an optical school may be operated in conjunction. The city already has an engraving school. Definite action will be taken within a month or two.

Col. Sidney O. Bigney Elected Delegate at Large to the Republican National Convention.

ATTLEBORO, Mass., April 11.—Sidney O. Bigney, of S. O. Bigney & Co., is to-day one of the most pleased and also one of the most conspicuous men in Massachusetts, for Friday the Republican State Convention chose him one of the four State delegates-at-large to the national convention. To secure this honor, which for years has gone to men high in the political ranks, and not to business men, required a campaign which will not be forgotten by the present generation of political students in the State for its strenuousness. The last few days were particularly spectacular.

Thursday night, when it was well settled that Col. Bigney had won, all opposition having been literally frightened out of the contest, he gave a reception in the American House, Boston, at which excited hundreds accepted his hospitality, insisted on placing him at their head and parading the corridors, and cheering Bigney and Taft to the echo, until the early morning hours. A song in his honor was enthusiastically sung by the crowds. In the convention the next day, Col. Bigney's influence was potent in helping shape the acts and policies of the party.

The argument made in his favor all through the campaign for this place was that it was time the party ceased to bestow these temporary honors upon office holders already well honored, but should give them to some of the leaders of industry, who have neither time nor inclination to take office in the ordinary sense.

Hugh Murray, Danville, Ky., Goes Into Voluntary Bankruptcy.

DANVILLE, Ky., April 8.—Hugh Murray, who conducted an extensive jewelry business here, recently filed a petition in bankruptcy, and his schedules show liabilities to be about \$14,000 and his assets about \$11,000. The principal merchandise creditors are in Cincinnati, Chicago and New York.

Mr. Murray, who was originally employed by his brother in Pulaski, Tenn., came to Danville about eight years ago, and with W. B. McAdams started in business under the style of Murray & McAdams; the firm continued until 1905, when Mr. Murray succeeded to the business, which he has continued alone since that time.

Death of Stephen Avery.

In the death of Stephen Avery, of the firm of Avery & Brown, 68 Nassau St., which occurred last Thursday night at his residence, 140 W. 130th St., the jobbing trade of New York lost one of its most esteemed and highly respected members. His death, which was caused by pneumonia, was sudden and unexpected, and comes as a shock to his many friends and acquaintances, both in New York and throughout the country generally.

Stephen Avery was born in Brooklyn, June 29, 1852, where he received his early education. He obtained employment as a boy



THE LATE STEPHEN AVERY.

in Robbins & Appleton's New York office in the early 70's, but because of poor health he was compelled to give up his work and rest a year, during which time he traveled extensively.

After he had recovered his health he again became employed by Robbins & Appleton, and his strict attention to duty and diligence won the respect and esteem of all with whom he came in contact. By his business ability and integrity he came to be the manager of the New York office, which position he held for a number of years.

In 1894 Mr. Avery started in business for himself, and in 1895 he formed a partnership with A. L. Brown, under the title of Avery & Brown. He was connected with the firm up to the time of his death.

Mr. Avery was a member of the 24 Karat Club, the Drug and Chemical Club, Crescent Athletic Club, and the Republican Club. He is survived by his mother.

The funeral services were held from the late home of the deceased last Saturday night. The interment was at Hudson, N. Y. Among the many floral pieces which accompanied the remains to Hudson was a large wreath sent by the members of the Jewelers' 24-Karat Club.

Mr. Nelson, Watertown, S. Dak., has sold his stock in the Harrington building, and will go to the Pacific Coast, in the near future.

Chester Billings & Son

1840

Successors to
Kandel, Barmore & Billings

1908

Importers of Diamonds
Other Precious Stones, and
Pearls, Diamond Jewelry

1840, Kandel & Barmore; 1866, Kandel, Barmore & Co.; 1880, Kandel, Barmore & Billings;
1897, Chester Billings & Son

New York, 58 Nassau Street, 29 Maiden Lane
London: 22 Holborn Viaduct, E. C. Paris: 53 Rue de Chateaudun
Amsterdam: 2 Tulp Straat

GEORGE H. HODENPYL.

WALTER N. WALKER.

HODENPYL & WALKER

IMPORTERS OF

DIAMONDS

OTHER PRECIOUS STONES
AND PEARLSMANUFACTURERS OF
FINE DIAMOND JEWELRY

373 FIFTH AVENUE,

NEW YORK

Corner 35th Street

Telephone, 5093 Madison Square

EISENMANN BROS.

IMPORTERS OF

Pearls and Precious Stones

452 Fifth Avenue, New York
cor. 40th St., Knox Building

3 Rue St. Georges, Paris.

Gems and Precious Stones

Their Characteristics, Localities of Production, Tests
and Some Current Literature

CLOTH, POSTPAID, \$1.00

Published by THE JEWELERS' CIRCULAR PUB. CO., 11 John St., N. Y.

Ludwig Nissen & Co.

182 and 184 BROADWAY
NEW YORK

PEARL
NECKLACES
AND
DIAMOND
COLLARETTES

Mounted Diamond
Jewelry of Every
description :: ::

Largest assortment
of all kinds of very
fine, fancy and rare
gems, including
Pearls, Diamonds,
Emeralds and
Sapphires :: ::

PARTICULARLY
FANCY COLORED
AND FANCY
SHAPED DIAMONDS

Ludwig Nissen & Co.

182 and 184 BROADWAY
NEW YORK

Death of Edgar L. Logee.

PROVIDENCE, R. I., April 9.—The sudden death of Edgar L. Logee at his home, 37 Adelaide Ave., this city, Monday, caused a feeling of universal sorrow among the manufacturing jewelers in this section of the country and robbed the trade of one of its most enterprising and successful members. For years the name of E. L. Logee has been synonymous with emblems and charms of all secret organizations and he was perhaps the largest manufacturer of that grade of goods in the country. From a modest beginning he, by his indomitable will and progressive



THE LATE EDGAR L. LOGEE.

spirit, built his business to one of the largest in New England, and his advice in business matters was sought by persons who, when they followed it, found that they obtained results.

Mr. Logee was born in New Bedford, Mass., in 1851, and was educated in the public schools of that city. He came to Providence about 25 years ago and became connected with the firm of Newell & Downs, manufacturing jewelers of this city. Later he became affiliated with the firm of George C. Case & Co. on Potter St., and was made manager of their shops. After several years he purchased Mr. Case's holdings, and with R. L. Moorehead formed a co-partnership under the firm name of R. L. Moorehead & Co. Until 1891 this firm continued to do business, and then Mr. Moorehead acquired the stock held by Mr. Logee. The latter then began business under the name of E. L. Logee & Co., and engaged in the manufacture of emblems. He made it a point to manufacture only the highest class of goods and the result was that his shops were kept busy at all times.

Deceased was a punctilious business man and was always at his desk at 7 o'clock in the morning, remaining until closing time

at night. Despite the fact that he has been anything but a well man for the past year he was at his shop daily and continued to maintain the same interest in business affairs that he did when the firm first started.

Mr. Logee is survived by a widow and a daughter by a former marriage. He was a member of Jenks Lodge A. F. & A. M., Pawtucket Royal Arch Chapter, Pawtucket Council, St. John's Commandery Knights Templar, Scottish Rite, and of Palestine Temple of the Mystic Shrine.

The funeral was held to-day from his late residence. The service was read by Rev. John A. McColl, of the Pilgrim Congregational Church, and at the conclusion of this the impressive ritual of the Knights Templar was conducted. The large drawing room at the residence of the deceased was filled with floral tributes from employes, friends and the organizations with which he was affiliated. The Templar quartette rendered "Face to Face," "I Am a Pilgrim," and "Sometime We'll Understand." After services at Swan Point Cemetery conducted by St. John's Commandery, the body was entombed.

The bearers were Sir Knights William F. Smith, Horace E. Remington, Thomas H. Rhoades, Charles A. Stone, Frank E. Dessley and Richmond J. Stone.

Death of Frank Mauser.

Frank Mauser, manufacturing silversmith, 103 Oliver St., Newark, N. J., who for many years had been connected with the silverware trade in New York and in North Attleboro, died suddenly last Friday at the Campbell undertaking establishment, 241 W. 23d St., New York. Mr. Mauser entered the undertaking establishment late Friday afternoon, and while making some inquiries, suddenly expired.

W. F. Mauser, son of the deceased, when seen at his home, 521 W. 173d St., said that the cause of his father's death was unknown to him. He knew nothing of the matter until he received a telephone message calling him to the undertaking establishment. A letter was found in the dead man's pocket which was addressed to the son and was turned over to him when he reached the undertaking establishment. The letter was purely of a business nature and contained no reference to other matters.

News of Mr. Mauser's death came as a shock to his many friends and acquaintances in the trade, who join in extending sympathy to the deceased relatives.

Frank Mauser was born Sept. 8, 1844, at Eibach, Wurtemberg, Germany, and learned his trade in Gemund in the same province. He came to New York in 1866 and secured employment as a silversmith with Ball, Black & Co., with whom he remained about two years, and then went with the Whiting Mfg. Co. as foreman in the factory at North Attleboro. When that plant was moved to New York he remained as foreman in the factory for 21 years. He was next employed by Geo. W. Shiebler & Co. as foreman of their Brooklyn factory and later went back to North Attleboro and entered the employ

of F. M. Whiting & Co., with whom he remained about five years.

About 1887 Mr. Mauser went into business for himself at North Attleboro in partnership with Orin Combs, under the firm style of Frank Mauser & Co. The business was later removed to New York and located at 30 Union Sq. This business was later taken over by the Mauser Mfg. Co., and Mr. Mauser returned to the Whiting Mfg. Co. as factory superintendent, with whom he remained a number of years. For a time he was not connected with the trade, but last June he started in business for himself at 103 Oliver St., Newark, as the



THE LATE FRANK MAUSER.

Frank Mauser Co., with which concern he was connected at the time of his death.

Deceased was a member of German Union Lodge 54 F. & A. M., Aurora Lodge 107 I. O. O. F., North Attleboro, and of the Jewelers' League. He was a practical silversmith and a master of his trade. During his many years of experience he formed a wide circle of friends, who speak of him in words of highest esteem.

The funeral services were held Monday evening from the Campbell undertaking establishment in New York.

Mr. Mauser is survived by a widow, one son, W. F. Mauser, and a sister, Mrs. John Ryan.

Death of Jacob J. Miller.

MILWAUKEE, Wis., April 11.—Jacob J. Miller, a well-known engraver and watchmaker and at one time a member of the jewelry firm of Miller & Bloedel, now A. Bloedel, died in this city, yesterday, aged 68 years. Mr. Miller retired several years ago and spent the declining years of his life at his home, on Keefe Ave.

The deceased engaged in business in Kansas City, in the year 1885, but failed after reverses and the business was afterwards conducted in the name of his wife.

Mrs. E. E. Vanderberg has sold out her jewelry business in Tacoma, Wash.

ADDISON W. WOODHULL, President.
FRANK K. HUFF, Vice-President.

GILBERT T. WOODHULL, Treasurer.
WILLIAM J. McQUILLIN, Secretary.

MOUNT & WOODHULL,

IMPORTERS OF **DIAMONDS,**
OTHER PRECIOUS STONES,
PEARLS, ETC.

MAKERS OF **FINE**
DIAMOND
JEWELRY. **26 Maiden Lane,**
(Southwest Corner Nassau Street)
NEW YORK

EMERALDS, DIAMONDS AND PEARLS **CABLE ADDRESS: MILBAGG**

BAGG & CO.
Successors to BAGG, PERINE & CO.
IMPORTERS
452 FIFTH AVENUE, at 40th Street
NEW YORK

TELEPHONE NUMBERS: 917-918 BRYANT **RUBIES AND SAPPHIRES**

DIAMONDS **TRY US ON** *Lissauer & Company* IMPORTERS
52-54 MAIDEN LANE, NEW YORK

A. ROSEMAN, 9-11-13 Maiden Lane, New York
IMPORTER OF **DIAMONDS** *Established 1872*
HEADQUARTERS FOR **AMERICAN WATCHES**
Maker of Diamond Jewelry *TRADE-MARK.*

VARISCITE **SOHN & HYMAN**
47-49 MAIDEN LANE
The Newest Stone for High Class Jewelry **NEW YORK**

Tel. 4457 } Cort. **JOHN M. RICHARD** 2 MAIDEN LANE
4458 } Room 302, NEW YORK
American Pearls and Baroques
MATCHED PAIRS FOR EARRINGS The Largest and Finest Assortment in the Market, Mounted and Unmounted.

CENTENNIAL TIMERS

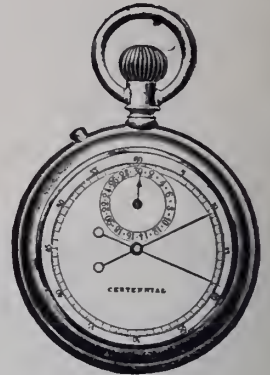

- ☞ Without question the best plain and split second timers made.
- ☞ Register with scientific precision. Substantially built and mechanically perfect.
- ☞ Invaluable for athletic, mechanical and scientific observations. Cased in nickel. Much in demand during the racing season.
- ☞ We also carry split chronographs with minute registers, cased in gold, gold filled and sterling silver.
- ☞ All makes of American cases and movements.



Cross & Beguelin

31 Maiden Lane, N. Y.
Established 1863 Telephone 480 John

Bankruptcy Petition Filed Against Chas. F. Wood & Co.—Liabilities Said to be \$525,000 and the Assets \$240,000.

A petition in involuntary bankruptcy was filed late Saturday afternoon in the United States District Court, New York, against Charles F. Wood, John B. Wood and Elmer E. Wood, composing the firm of Charles F. Wood & Co., importers of diamonds, 1 Maiden Lane, New York, by the following creditors: Jac. Kryn & Wauters, \$20,000; Joseph H. Fink & Co., \$5,000; Stern Bros. & Co., \$4,000, all of whose claims are claimed to be in excess of the amounts named in the petition and are for goods sold and delivered at various times.

It is alleged that C. F. Wood & Co. are insolvent and that they committed an act in bankruptcy in that they transferred a certain portion of their property to one or more of their creditors with intent to show preference and that they transferred and concealed property with intent to hinder, delay and defraud their creditors.

The assets are said to be about \$240,000, with liabilities of \$525,000. George R. Whitehead has been appointed receiver of the business, under a bond of \$50,000.

In the petition asking for the appointment of a receiver the assets are estimated by the creditors as follows: Merchandise, \$157,000; open accounts, \$26,000; real estate, \$25,000; surplus in jewelry pledged, \$16,000; surplus in pledged bills receivable, \$16,000; total, \$240,000. The stock on hand, valued at \$157,000, consists of diamonds and other precious stones and jewelry, some of which is mounted.

The liabilities are placed at \$525,000, of which amount Jac. Kryn & Wauters hold claims for about \$350,000. European creditors are named for \$30,000; Bruhl Bros. & Henius Co., Joseph H. Fink & Co., Oppenheimer Bros. & Veith, Eduard Van Dam and others have claims aggregating \$91,000. It is alleged Marchand Freres are creditors for about \$11,000.

It is stated that Auguste Wauters approached the Wood firm to collect a claim and learned that the concern was insolvent and the members admitted their insolvency to Mr. Wauters, says the petition, and have since then admitted insolvency to other petitioning creditors. A meeting of creditors was held last week, at which time it was decided to file the bankruptcy petition.

Hays & Hershfield and Turner, Rolston & Horan are the attorneys for the creditors and for the receiver.

Mr. Blanc, of Turner, Rolston & Horan, when seen by a CIRCULAR-WEEKLY reporter Monday, said that the receiver had taken possession and is having experts go over the books, and that he will be able to make a general statement in a few days. Mr. Blanc said that meetings of creditors were held last Friday afternoon and Saturday morning at the offices of Marchand Freres, at which a large majority of creditors were present. It was the consensus of opinion of this meeting that a petition in bankruptcy be filed and the creditors present were unanimous in the choice of Mr. Whitehead as the desired receiver. He was appointed by Judge Hough Monday morning, with the understanding that he was the choice of the creditors.

Mr. Wolf, of Hays & Hershfield, attorneys for the petitioning creditors, said late Monday afternoon that the liabilities in unsecured claims would amount to about \$550,000 and the secured claims, he said, were about \$150,000. The receiver is in charge of the stock. Mr. Wolf said that there was very little accommodation paper in this case and that it would take another day or so to get more accurately at the value of the assets.

Geo. R. Whitehead, the receiver, said he was not in a position to make any statement as to the case at present.

L. F. Reed, attorney for Chas. F. Wood & Co., attributed the trouble to the financial condition and trying to carry a lot of debtors. He said little business had been done in the past few months. He placed the liabilities, roughly, at \$500,000. He said the firm offered to make a voluntary petition. He also spoke of some stock in gem mines held by the firm in California, but gave out no figures.

The business was started in September, 1872, by Charles F. Wood, and in 1874 the firm became Dolbey & Wood, and so remained until 1878, when Mr. Wood succeeded to the business. In December, 1892, John B. and Elmer E. Wood were admitted as partners, the style being changed to Chas. F. Wood & Co.

Involuntary Bankruptcy Petition Filed Against Herman Streiff, New York.

A petition in involuntary bankruptcy was filed last Saturday in the United States District Court, New York, against Herman Streiff, wholesale dealer in jewelry, 415 Broadway, by these creditors: Attleboro Mfg. Co., \$840; Attleboro Chain Co., \$405; and the Lyons Mfg. Co., Providence, R. I., \$507. It is alleged that Streiff is insolvent and that he made preferred payments to creditors and transferred property. On April 3, it is alleged, he transferred a stock of goods at his store, 58 Market St., Newark, to a relative named Lobel, and it is stated that he had only \$300 worth of stock at 415 Broadway.

The petition says that when Irving Looker, representing the Attleboro Mfg. Co., questioned Mr. Streiff as to payment of bills, he was told that it was impossible to do this. The petition goes on to say that Streiff told Louis Schoenberg, agent for the Lyons Mfg. Co., in January, that he was worth \$15,000 above his liabilities. His liabilities to creditors are said to be upward of \$10,000.

Herman Streiff was previously a member of Streiff & Cardon, Passaic, N. J. He discontinued his business at 23 Lispenard St. a few months ago and opened at 415 Broadway.

Market Price for Silver Bars.

The following are the quotations of silver bars in London and New York, as reported by Zimmermann & Forshay:

	London.	New York.
		.999 Basis.
April 7.....	25 3-8d.	57
" 8.....	25 5-16d.	56 3/4
" 9.....	25 1-4d.	56 3/4
" 10.....	25 3-16d.	56 1/4
" 11.....	25 3-16d.	56 1/4
" 13.....	25 3-16d.	56 3/8

Christopher Staiger's Suit Against Jung & Klitz Dismissed on a Technicality.

Judge Maddox in the Supreme Court, Brooklyn, last Wednesday, dismissed on a technicality the equity suit of Christopher Staiger, which he brought against his former partners, Robert H. Klitz and Charles R. Jung, now of the firm of Jung & Klitz, New York. The action brought was to set aside a settlement and release made in the dissolution of the partnership between plaintiff and defendants, upon the grounds of fraudulent representations and promises.

The plaintiff in this case and the defendants were formerly partners under the firm name of Jung, Staiger & Klitz. In January, 1906, an agreement was entered into by which the firm dissolved. The result of the agreement was that Mr. Staiger withdrew from the concern and sold his interest to the other members at a specified value, which included his release from all debts against the old firm. Some time after the partnership dissolution was put through an action was brought against the other two members of the firm by Mr. Staiger upon the ground that the firm did not include certain property in an inventory which was made the basis of the settlement, and that they had withdrawn their capital from the business, and that they had understated Mr. Staiger's interest in the business.

The defendants put in a general denial of the claim of fraud and fought an examination before trial, claiming that the partnership books had been transferred to them and that the rule in reference to permitting a partner to have an inspection of the firm's books was not applicable. The plaintiff deemed it necessary to inspect the books of the defendants, and the lower court decided that the rule applied in this case and ordered an inspection of the books. This point was appealed and an order granting the inspection was obtained from the higher court.

Examinations before trial were held and a bill of particulars submitted by the plaintiff's attorney, Henry Schoenherr, which set forth alleged fraudulent statements in the statement of assets and liabilities submitted by the defendants at the time of the partnership dissolution.

When the matter came up last week before Judge Maddox, he held that because the plaintiff did not allege in his complaint that he had returned the amount he had received from the defendants he could not therefore recover what he claimed he had been defrauded of.

Argument for a new trial will be heard to-day before Judge Maddox.

Jewelers' Gold Bars Withdrawn and Exchanged at New York.

Week Ended April 11, 1908.
The U. S. Assay Office reports:
Gold bars exchanged for gold coin.....\$278,416.25
Gold bars paid depositors..... 40,508.83

Total	\$318,925.08
Of this the gold bars exchanged for gold coin are reported as follows:	
April 6.....	\$41,093.15
" 7.....	50,790.84
" 8.....	56,622.89
" 9.....	21,245.18
" 10.....	78,006.86
" 11.....	30,657.03
Total	\$278,416.25

WM S. HEDGES & CO.,

IMPORTERS AND CUTTERS OF

DIAMONDS.

Precious Stones and Pearls.

170 Broadway, Corner Maiden Lane, New York.

27 Holborn Viaduct, London.

JAGERSFONTEIN

and other Gem Diamonds

SAUNDERS, MEURER & CO.

65 Nassau Street

NEW YORK

Goodfriend Bros.

Importers of

Pearls and
Precious Stones

CAMEOS

9-11-13 Maiden Lane

NEW YORK

PARIS
10 Rue Cadet

PROVIDENCE
212 Union Street

Death of Isaac Speyer.

CHICAGO, April 12.—Isaac Speyer, secretary of the Goldsmith Bros.' Smelting and Refining Co., died at his home, 4941 Michigan Ave., Thursday, after a short illness, and was buried to-day at Waldheim cemetery.

Isaac Speyer, or "Ike," as he was familiarly known to the trade, began his career with the house of Goldsmith Bros. at the age of 17. His rise was rapid, and when the firm became a corporation, Mr Speyer was made its secretary. For years



THE LATE ISAAC SPEYER.

he traveled south and southwest and his genial personality won for him a host of friends. His loss is felt by all who knew him. Deceased was 40 years old at the time of his death. A widow survives him

Importations at the Port of New York.

<i>Weeks Ended April 6, 1907, and April 4, 1908.</i>		
	1907.	1908.
China, Glass and Earthen Ware:		
China	\$67,045	\$65,647
Earthen ware	10,789	10,291
Glass ware	36,792	18,120
Optical glass	1,799	6,811
Instruments:		
Musical	6,225	12,179
Optical	10,495	4,886
Philosophical	616	1,776
Jewelry, etc.:		
Jewelry	10,089	31,203
Precious stones	508,506	91,781
Watches	25,655	16,086
Metals, etc.:		
Bronzes	824	5,776
Cutlery	54,542	23,886
Dutch metal		2,898
Platina	56,918	9,303
Plated ware		
Silverware	4,302	1,302
Miscellaneous:		
Alabaster ornaments	151	18
Amber	211	1,177
Beads	6,962	2,151
Clocks	4,935	2,731
Fans	6,686	8,084
Fancy goods	4,791	8,684
Ivory	1,177	779
Ivory, manufactures of...	487	64
Marble, manufactures of...	27,539	25,317
Statuary	45,143	9,662

Weber Bros., Foley, Minn., are closing out their stock at auction.

Man Arrested in Savannah Brought to Newark, N. J., to Answer Charge Made by Jeweler.

NEWARK, N. J., April 10.—Detectives returned to Newark Tuesday evening from Savannah, Ga., with Elias Palter, of Miami, Fla., who is wanted to answer the charge of stealing a diamond brooch pin valued at \$210, which it is alleged he obtained from Louis Swirsky, 250 Springfield Ave., last July. Palter formerly lived in Newark. He was arrested by Savannah police April 10 and held for extradition papers.

Palter is well known to the jewelry trade in New York, having at one time had an office in the Maiden Lane district. Some time ago he visited jewelers in Savannah, Ga., and endeavored to sell them diamonds, and he was in Savannah a few weeks ago endeavoring to get employment, after which he went to Jacksonville, Fla., and then to Miami, Fla. After visiting Miami he returned to Savannah, Ga., to look after a suit of his against a railroad, and was arrested there. Palter claims that he has done nothing wrong, though he admits having sold the goods which he had, in the regular way.

At the office of Louis Swirsky, the Newark complainant, it was said that Palter came there and asked for a diamond brooch with the privilege of showing it to a second party before he made the purchase, and with the understanding that he would either return the brooch or pay the jeweler its money value. It was said that he neither returned the brooch nor made any offer to pay for it, and the jeweler set about to have him arrested. He was indicted last September for larceny.

The Bureau of Standards and Its Work at Rating Watches.

BUREAU OF STANDARDS,

WASHINGTON, D. C., April 10, 1908.

EDITOR THE JEWELERS' CIRCULAR—WEEKLY: Referring to the article contained in THE JEWELERS' CIRCULAR—WEEKLY of Wednesday, April 1, 1908, about the testing of watches at the Bureau of Standards, we would state that the article is somewhat misleading, inasmuch as we are not yet prepared to test watches for the general public.

The watches which were loaned by the firms mentioned in your article were for the purpose of making a preliminary investigation of the behavior of the best grade of commercial watches as carried by jewelers. It will be some time, perhaps a year, before we are ready to take up the regular testing of watches for the trade and for the public generally. Respectfully,

(Signed) S. W. SHATTON
Director.

C. I. Yaeger, St. Paul, Minn., Files Voluntary Petition in Bankruptcy.

ST. PAUL, Minn., April 8.—C. I. Yaeger, owner of the Twin City Jewelry Mfg. Co., 138 E. 7th St., this city, has filed a voluntary petition in bankruptcy in the United States District Court.

Mr. Yaeger's liabilities are given as \$1,484.60, all unsecured claims, and his assets are \$9,750, of which \$4,625 is claimed as exempt.

Mr. Yaeger had been engaged in the

jewelry business here for over 16 years. The amount of stock which he carried was small and the business was not an extensive one.

Safe Blowers Rob San Francisco Jewelers of \$50,000 Worth of Jewels.

SAN FRANCISCO, April 11.—Burglars some time last night broke into the retail jewelry store of Thomas Lundy, 744 Market St., this city, and after blowing open the safe by means of nitro-glycerine, made off with stock valued at \$50,000. The store is located in the heart of the business district and was guarded by watchmen and the police.

Entrance was gained by cutting a hole through the partition which separates the jewelry establishment from a candy store. It is the opinion of the police that the robbery was committed by eastern crooks, many of whom have arrived in this city, recently. The work of the burglars is considered especially daring in view of the fact that they worked on the safe while an electric light burned brightly directly overhead.

Every compartment in the safe was ransacked but only jewels were taken. The cunning and experience of the intruders were evinced by the fact that several watches were left behind, not a single one having been taken.

Sneak Thieves Steal Jewelry Worth \$2,500 from Salt Lake City Store.

SALT LAKE CITY, Utah, April 10.—The fact that a clever robbery had been committed at one of the leading jewelry stores of this city, has just been made public through the report of the matter to the police, and detectives are now working on the case, though no clue to the perpetrators has as yet been obtained.

The robbery was committed on the Boyd Park Jewelry Store, 170 Main St., some time Saturday afternoon, while the place was full of shoppers, though the exact time is not known. The thieves, presumably women got away with a small tray containing 15 diamond studs and nine pearl studs, valued in all at \$2,500. The gems were taken from the diamond show case and the sneak thieves, whoever they were, must have worked very cleverly.

In addition to the regular police force, a local detective has been put on the case, and a reward of \$250 has been offered for the recovery of the goods with a similar amount additional for the conviction of the thieves.

The first reports gave the loss as \$6,000, but this proved to be exaggerated.

Sprague Bros., Ada, Okla., are offering \$75 reward for the arrest of the thief and the return of the articles stolen from their store March 16. The articles, which were in all valued at \$300, consisted of one Carmen gold-filled chased bracelet; one Norma gold-filled bracelet, four sets; one Norma gold-filled bracelet, one cameo setting jointed bracelet, two solid gold pony vest charms and two dozen metal gold-filled fobs, hair safety attachments. The concern will pay \$25 for the return of the goods and \$50 for the arrest and conviction of the thief.

Last Tribute to the Late U. C. Smith, Brockton, Mass.—Business to be Continued.

BROCKTON, Mass., April 11.—Announcement was made to-day that arrangements have been made to continue the retail jewelry and optical business of the late Uriah C. Smith, 92 Main St., without interruption. Mr. Smith, whose untimely death was noted last week, left a large and prosperous store, an unusually well developed optical business, and Mrs. Smith has decided to keep both in full operation as her own property, using the old business style, U. C. Smith. Loring Smith, a namesake but not a relative, who had been a trusted employe of the late owner for 14 years, has been retained as manager, and the customary force of nine clerks will be continued. F. W. Worthing remains in charge of the optical department.

The funeral of Mr. Smith earlier in the week was a signal proof of the esteem in which he was held by a community in which he had lived and done business over 21 years. From 1 to 2.30 in the afternoon, while the services were in progress, the entire mercantile district suspended business. A large number of business men attended the services, flowers were sent in great profusion, and practically every other jewelry concern in the city was represented by some tribute.

Rev. Dudley Hays Ferrell, of the Church of the Unity, conducted the rites and representatives were present from the Masonic bodies, the Commercial Club, business associates and competitors, the Brockton Roque association and other bodies. Favorite hymns were sung and the remains were laid to rest in the family burial lot.

J. Edward Boeck, Missing Diamond Broker, Brought to New York and Held in \$50,000 Bail on Larceny Charges.

Central office detectives returned to New York City last Wednesday night from San Francisco with J. Edward Boeck, who was arrested in that city March 17 charged with the theft of pearls valued at \$125,000 from New York dealers. He was taken before Judge Crain in General Sessions and held in \$50,000 bail.

Boeck was formerly a precious stone broker and dealer in antiques and had office room at 170 Broadway, New York. He obtained a large quantity of valuable gems and jewelry from Edwin W. Dayton, a New York dealer, with the understanding that he was to sell the property on commission. He disappeared in May, 1907, and since that time has eluded the officers of the law who were seeking him. At the time of his disappearance numerous stories were told of Boeck's connection with people high officially in the Chinese government.

Among the firms who have claims against Boeck are Ludwig Nissen & Co., A. H. Smith & Co., Edward W. Dayton and Marsellus Pitt & Co., all of New York. The complainants against him as named in the indictments are Edwin W. Dayton and Marsellus Pitt & Co. There are a number of charges against Boeck pending at the present time.

BLACK OPALS

REMARKABLE :: IRIDESCENT :: BEAUTIFUL

Black Opal, a recent Australian discovery, is one of the most beautiful stones hitherto found.

With its many inimitable jewelry creations are possible that must appear in a forceful manner to the trade.

These remarkable stones exhibit a wonderful play of brilliant colors, ranging from light to cobalt blue, with flashes of violet, from delicate shades of green to peacock green, and all shades of reds, merging into orange and yellow tints.

Black Opal is a worthy addition to the finest stock, and jewelers will find it a welcome "Trade Magnet."

We can furnish these stones in various sizes and shapes, and their full merits can only be appreciated by being seen.

We make a specialty of AUSTRALIAN and MEXICAN OPAL MATRIX.

BUY FROM THE CUTTERS

AMERICAN GEM & PEARL COMPANY

14 & 16 CHURCH STREET, NEW YORK

London, 16 Holborn Viaduct

Paris, 39 Rue de Chateaudun

FROM MINES TO MARKET

Philadelphia.

I. Kenter, retailer, 2d St., below Girard Ave., is remodeling his store to make it one of the most attractive in that section of the city.

It was announced, last week, that \$18,700 additional capital stock of the Keystone Watch Case Co. has been listed on the Philadelphia stock exchange.

James McMillan, of the material department of M. Sickles & Sons, is still ill at his home and is not expected to be able to resume his duties for about a month.

S. Simmons, watchmaker, formerly of New York, opened an establishment here last week at 731 Sansom St., where he will make a specialty of repair work for the trade.

Frank Braun, 1420 Susquehanna Ave., who has been quite ill, has completely recovered and resumed conduct of his store. He was suffering from a painful affection of the stomach.

S. P. Dayton, who has conducted a retail store for about a year at Milton, Pa., closed out his business there, last week, and now opens an attractive little store in this city at 2026 E. Tioga St.

R. Corry, for 15 years the local representative of the Wm. L. Gilbert Clock Co., 124 S. 8th St., has resigned his position and is reported to have entered into another business enterprise.

John W. Ford, Republican nominee for coroner, and a prominent retail jeweler and optician at 618 E. Girard Ave., was successful at the primaries Saturday by an overwhelming majority.

The Joseph Castleberg Jewelry Co., in this city, is now owned by Klopfer Bros., Mr. Greenberg having retired. Their store is in the Mint Arcade, an exceedingly attractive location. Business is reported as fair.

The Manayunk Optical Co., Manayunk, is now controlled entirely by J. A. Allen, who has purchased the entire interest of his partner, C. Huber. The business will be continued by Mr. Allen under the same style.

James Nelson, a retail jeweler of Camden, was summoned last week as one of the Grand Jurors for the April term of the Camden County Courts. The jury has been charged by Judge Garrison to investigate gambling.

Col. J. Warner Hutchins has been elected vice-president of the newly formed Republican Club of Pennsylvania, which has applied for a charter and which is formed from the membership of the now defunct old Union Club.

Owing to the death of J. M. Poland, of Poland Bros., jewelers and opticians at 447 Main St., Manayunk, the business is now solely controlled by A. Poland, the surviving partner, who continues the firm name of Poland Bros. as heretofore.

Charles H. Dean, of 715 Sansom St., says that the clean-cut and well-authenticated denials made by THE CIRCULAR-WEEKLY against any lowering in the price of diamonds have assisted materially in establishing more confidence in the local market.

J. E. Caldwell & Co. furnished a magnificent high case colonial hall clock for the Berks County Chapter, Daughters of the

CORAL

All Kinds of Coral
Specialties for Jewelers

DROPS
BUTTONS
LENTILLES

CORAL
NECK-
LACES

All Shades
and Sizes
Graduated and
Uniform



CORAL MANUFACTURING COMPANY

CORAL

Extra Rose
CORAL
A Specialty

Gold Medal
St. Louis, 1904

Grand Prix
Liege, 1905

BORRELLI & VITELLI

3 Via Amedeo,
Terre del Greco Italy

401 Broadway, New York
Telephone, 5412 Franklin

19 Rue d'Hauteville,
Paris, France

ARTHUR REICHMAN

DEALER IN

AMERICAN BAROQUE PEARLS

65 Nassau St.

New York

American Revolution, Reading, Pa. The clock will be placed in the Memorial Continental Hall of the society in Washington, D. C.

William H. Dawson, salesman with H. O. Hurlburt & Sons, who had been critically ill and unable to report for duty for about three weeks was again taken ill after being back only two days last week, and it is reported may be required to remain at home for an indefinite period.

Emil Weiss, formerly of Penn St., Reading, Pa., who became financially involved about six months ago and abandoned his retail store there, has resumed business in Reading on S. 6th St., where he has opened a store, conducting it under the name of the Novelty Jewelry Co.

I. Alton Deisher moved, last week, from 424 Penn St., Reading, to 514 Penn St., where he has larger and more attractive quarters. The new store is equipped with an elaborately furnished optical department and Mr. Deisher proposes in the future to devote much of his attention to this branch of his business.

Elmer Y. Ritter, associated in business with his father, Calvin W. Ritter, Pottstown, Pa., is receiving the felicitations of his friends in the trade of this section of the State on account of his recent marriage, at Pottstown, to Miss Bertha C. Skean. Mr. and Mrs. Ritter, after a honeymoon trip, will reside at 129 Beech St., Pottstown.

The Philadelphia Jewelers' Club promise another pleasant entertainment for its members and their friends on Tuesday evening, April 28, when a smoker will be given at the club rooms, Chestnut, below 13th St., and a breezy vaudeville entertainment provided. Admission cards may be had on application to A. J. Le Jambre, secretary.

The pool tournament between the members of the Jewelers' Club, which has been in progress some time, is nearing an end, with L. P. White, so far, in the lead for first honors. In the match last week between George W. Read and William C. Robertson, the latter was triumphant and is reasonably sure of being among the first at the finish.

The note in the last issue of THE CIRCULAR—WEEKLY, stating that Boris Oster would in future confine his attention to his establishment at 1910 Germantown Ave. and 719 Sansom St., was not correct, as it should be mentioned that the store at 719 Sansom St. is conducted by Green Bros., to whom Mr. Oster sold the business about a year ago.

William C. Robertson, manufacturing jeweler, 725 Sansom St., was summoned as one of the Sheriff's Jury, Thursday, to witness the execution by hanging of Warrick Brooks, a colored man convicted of murder. It was Mr. Robertson's first experience at an execution and he declares that it was such a sickening one that he will never serve again in the same capacity.

The sale of the stock of Naum Rosenbaum, bankrupt retailer, 19 S. 9th St., Thursday, attracted many retail jewelers and representatives of wholesale houses, who made purchases of comparatively new stock at bargain prices. Among those in the crowd of bargain hunters were H. Donath, Albert J. Ayres, C. R. Dotter, Ritter, Kohn & Co. and R. F. Ferguson. The sale

brought a fairly good total. The sale was ordered by Morris A. Ritch, receiver.

Efforts are being made by the retail jewelers of Kensington, especially the leading ones along Kensington Ave., to revive the agreement providing for the closing of all retail stores Thursday evening at 6 o'clock between Feb. 1 and Nov. 1. The agreement has not been carried into effect so far this year, it is reported, because of the rivalry between two or three of the most influential merchants.

After an illness of about three weeks with asthma, with which he had been long troubled, Charles A. Gabler, a watchmaker, widely known in this city, died Friday. He had been all his life in the trade of this city and for about eight years has conducted a repair establishment for trade work at 722 Chestnut St. He was about 60 years old. Of a genial, sunny temperament, he made and held a host of friends.

The business men of Germantown Ave. have formed an association to boom their locality and last Saturday (April 11) saw the commencement of a local carnival or celebration. All the stores and the avenue were brilliantly lighted and decorated in red and white, the colors of the association. It is needless to say that the jewelers and opticians of the avenue are among the leading spirits in the optimistic movement.

J. N. Taylor, Jr., trading as Taylor & Co., 11 S. 9th St., announced, last week, that he was compelled on account of the condition of his health to retire from business and has disposed of the lease and fixtures of his store to Seaman & Struntz, retail jewelers, 4517 Frankford Ave., who will occupy the store and conduct it as a jewelry store as soon as Mr. Taylor has vacated and the stock has been removed.

E. J. Berlet, of Maxwell & Berlet, retail jewelers, 13th and Walnut Sts., was, last week, elected president of the Walnut St. Business Men's Association, which is formed to advance the interests of the merchants along that thoroughfare and press for needed municipal improvements. The meeting, at which Mr. Berlet was honored with election as head of the new association, was held in the Bellevue-Stratford Hotel. Mr. Berlet is one of the younger merchants of the street and one of its most progressive ones.

Business men, jewelers and opticians included, in that section of the city between the Delaware river front, 7th St. and Chestnut and Vine Sts., breathe easier now that four policemen who for two or three years have been systematically pilfering from stores in the neighborhood have been caught and railroaded to jail for long terms. They had made it a practice to forcibly break into stores during the night and steal. Among the goods recovered from a hiding place were much silver-plated ware and fancy leather novelties. It is not positively known from what establishment these were stolen.

A comprehensive collection of silverware made in this city in its early days is one of the features which it is proposed to embrace in the historical exhibition to be made for the celebration of Founders' Week, next Fall. At a meeting of the general committee, held in the mayor's office Saturday, Prof. Leslie W. Miller made the suggestion

that persons who have pieces of such silver be invited to communicate with him or with Edwin A. Barber, Memorial Hall, Fairmount Park. The following preliminary list of some of the older silversmiths has been submitted: John David, about 1780; James Musgrave, about 1797; Joseph Lowne, 1797 to 1811; Joseph Shoemaker, 1797-1819; P. Garrett, 1811-1831; Nathan Atherton, Jr., 1824; Fletcher & Gardiner, 1824; Harvey Lewis, 1824; Edward Lowne, 1830; Curry & Preston, 1830; R. & W. Wilson, 1830; Thomas Fletcher, 1830; Osmon Reed, 1843, and C. Bard & Son, 1850.

F. H. Voigt, watchmaker for the trade, 7th St., near Sansom St., sustained severe injuries Saturday afternoon by being struck by a huge hanging sign loosened from its fastenings at 7th and Chestnut Sts., during a violent wind storm. He was picked up unconscious and hurried to the Jefferson Hospital. While Mr. Voigt will recover, his injuries will incapacitate him from continuing his business for some weeks.

On suspicion of having been the men who three years ago robbed the jewelry store of Mrs. Liggins, at 11th St. and Girard Ave., of \$4,000 worth of goods, Philip Coyle alias Anderson, alias "Newark Phil," and Fred. alias "Short Arm" Reilly are under arrest in this city pending an investigation. Their arrest came about in an accidental manner. A young man was visiting a Tenderloin resort when he casually met a crowd of men in a room in the house. While drinking and smoking Coyle is alleged to have told the crowd about several robberies in which he had taken part and to have boasted particularly of the robbing of the Liggins store. By a curious coincidence Coyle is the man against whom suspicion first attached after the robbery had been perpetrated and he had then been arrested, but was later released for want of evidence. It may be recalled that Mrs. Liggins was alone in the store at the time and was chloroformed and the store pillaged while she remained unconscious. She had failed to identify Coyle. The men now under arrest are to be given a hearing Thursday. They are held without bail pending the completion of the investigations being made by the police department.

Buffalo, N. Y.

J. W. Jarvis, optician, has moved from his old quarters, 508 Main St., to 214 Franklin St., where he will be better able to care for his patrons. He has a factory 22 by 35 feet in dimensions, which is naturally lighted and splendidly arranged for an optical department.

To induce inspection of his stock of diamonds Charles F. Damm, 520 Main St., last week began offering to all visitors to his salesrooms as a free gift, a genuine opal. The gift is made simply to afford opportunity to Mr. Damm to show his unusually large and excellent stock of diamonds.

King & Eisele will shortly enlarge their quarters by taking the lower portion of the building which they now occupy at Washington and N. Division Sts., and annexing the portion now used for the optical part of the business, establishing a large repair department. The supply and optical departments will hereafter be located on the second floor.

EICHBERG & CO.,

IMPORTERS AND CUTTERS OF

DIAMONDS,

65 NASSAU STREET, (Prescott Building.) NEW YORK.

HIMALAYA MINING COMPANY

MINERS AND CUTTERS OF
PRECIOUS AND SEMI-PRECIOUS STONES

537 FIFTH AVENUE
NEW YORK

LONDON
PARIS

OBERSTEIN
PROVIDENCE

Boston.

Max Denzigeo has bought out the store of Mrs. M. F. Goodman on Broadway, South Boston.

Buyers in town during the week included Charles E. Dallman, Woonsocket, R. I.; H. F. Beaudry, Rockland, Mass.

W. Emery Clement, for a number of years in charge of the diamond department of D. C. Percival & Co., has severed his connection with the concern.

Richard F. Wilkinson, salesman for Nelson H. Brown, has been elected president of the Civil War Veteran Association of the 40th Massachusetts Volunteers.

M. C. Winsor, salesman for C. G. Aldrich Co., will hereafter represent also in New England territory the South Bend Watch Co., and the Rockford Silver Co.

Arthur E. Culverwell, Mark Feldman and Joseph Ross were before the Municipal Court, April 8, charged with larceny from the clock and jewelry department at Houghton & Dutton's store.

The New England Watchmakers' Club met April 8 at its rooms on Bromfield St., and heard a synopsis of a lecture by J. A. Freund, read by one of the members. The club's annual banquet is scheduled for to-morrow evening at the American House.

The Boston Jewelers' Band, which organized a few months ago, and has been practicing actively since, will fill its first public engagement May 5. The band is under the management of Eugene W. Rollins, who is with Nelson H. Brown, and is composed almost exclusively of members of the Boston jewelry trade.

The E. B. Horn Co., which has been located for the past 40 years at 427-429 Washington St., has just secured a new lease of the premises for a long term of years. A short time ago there was some expectation that a large department store, adjoining the property on both sides and at the rear, would secure the building, but the Horn Co. will now improve the property for its own occupancy, remodeling the entire structure and modernizing it.

New Bedford, Mass.

William H. Denham, Jr., a local jeweler and watch repairer, last week filed a voluntary petition in bankruptcy, and his schedules show liabilities of \$600 and assets of \$275. Mr. Denham has been in business here for several years, and carried a small stock, on which there was a chattel mortgage of \$275.

The reorganization of the A. L. Blackmer Co., manufacturing cut glass, which went into the hands of trustees March 26, is now taking place, and a company is being formed known as A. L. Blackmer & Co., Inc., to take over the plant and good-will of the old company, and to continue its already established business. Arthur L. Blackmer states that with the changes to be made necessary for handling the new business the new management will be in better position to fulfil obligations than was the old and that pending the reorganization the factory is being operated and all order executed as usual. The new concern will continue the same policy and produce the same line of goods which gave the old company its high reputation in the trade.

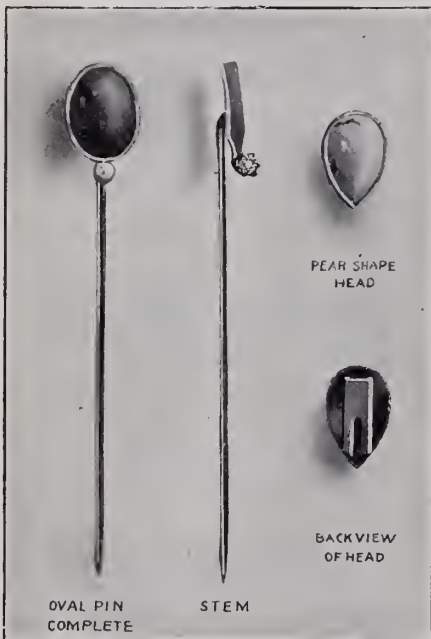

Interchangeable Scarf Pin

PATENT PENDING

Every smart dresser wears a scarf pin to harmonize with his cravat. Our new device allows the wearer to use a one-stone diamond in combination with any other colored stone, such as Lapis Lazuli, Moonstone, Turquoise Matrix, Jade, Topaz, Amethyst, Garnet, etc., by merely sliding the colored stone on the pin, as shown in illustration. Easy to attach or detach—nothing to break. Made in 14 Kt. only.

ROTHSCHILD BROS. & CO.



The Locket House 51-53 Maiden Lane, New York

Frank Dederick.

Established 58 Years.

James E. Dederick

James H. Dederick's Sons, Assayers and Bullion Dealers.

All qualities of Gold and Silver, in Plate, Square and Round Wire, Rolled to any gauge. We are selling fine gold for \$1.04 per dwt. which we guarantee to be government assay bars. Small rolling for the trade.

ALL QUALITIES OF GOLD AND SILVER SOLDER.

16 Maiden Lane

We buy Old Gold and Silver.

NEW YORK.

OUR BUSINESS

DIES

Established and in business since 1894

We have been giving satisfaction for the past 14 years.

FINE DIE WORK IS ESSENTIAL FOR FINE JEWELRY, SILVERWARE, ETC. Write us and let us submit for your approval a selection of original designs, made especially to suit your needs.

CREES & COURT

Die Sinkers and Designers
21 Eddy St., PROVIDENCE, R. I.

Pittsburg.

The Arcade Jewelry Co. is the name of a new concern which has opened for business in the Fifth Ave. arcade.

S. Davis & Co. last week passed around the cigars, because of the fact that the firm celebrated its 15th anniversary in business.

E. P. Roberts & Sons have been making a display of cups which have been sold to some of the bowling leagues of this city.

T. H. McNary, of Washington, and Frank Blöser, of New Kensington, were in Pittsburg last week, attending the automobile show.

A. A. Gillespie, of Gillespie Bros., is visiting friends in Chicago. Gillespie Bros. have repainted their store, and are getting ready for the Spring and Summer trade.

A number of the local stores are making preparations to have some fine displays of Easter goods this week, and a few houses have arranged with florists to decorate their stores.

W. W. Wattles, Sr., who has been in Florida for the last month or two, is again back at work and is just as active as ever, notwithstanding that he is the oldest jeweler in Pittsburg.

A fire which started early Saturday morning at 529 Wylie Ave. drove Antonio De Paris, a jeweler, and his family, who resided next door, into the street, because of the dense smoke which the blaze made. No damage was done his building, except to smoke up the interior.

Thieves gained entrance to the store of Jacob Wieszis, 401 Locust St., McKeesport, last Friday morning and robbed the establishment of a number of cheap watches valued at about \$50. The Ellsworth Supply Co., of the same town, was also recently robbed of some watches and chains.

Word was received in Pittsburg last week of the partial destruction of the Lafayette Hotel block at Meadville, and damage by water to the store of Gordon & Reamer, which is situated in the hotel block. So far as could be learned, the loss to the firm was principally by smoke and water. It is stated that Gordon & Reamer will at once repair whatever damage has been done.

W. W. Wattles & Sons last week made a display of semi-precious jewels to match gowns, and the exhibit attracted more than ordinary notice, being the first thing of the kind attempted by the leading jewelers of Pittsburg. It is now a fad among the wealthy women to buy the less expensive jewelry inlaid with stones of various design to match their dress goods, and the Wattles house demonstrated what can be done when taste is used.

The following out-of-town jewelers were in the city last week: Frank Murdock, Ligonier; R. A. Cunningham, Leechburg; Miss McKinney, East Liverpool; Asa Joseph Donora; John Linnenbrink, Rochester; H. C. Morrison, Mt. Pleasant; J. F. Murphy, Dawson; H. A. Jackson, Saltsburg; Guy Hutchinson, Kittanning; Carl Leighner, Butler; J. F. Murphy, Dawson; L. B. Mather, New Castle; D. E. Baker, Washington; T. M. Smith, Morgantown; F. A. Robinson, Clarksburg.

The manager for a local jobbing house has forwarded to Congressman Vreeland, at Washington, a petition signed by 30

wholesale and retail jewelry firms of this city, requesting that his bill discontinuing the stamping of the guarantee on filled watch cases be passed. Most of those who signed the petition are retailers. John M. Roberts, of the John M. Roberts & Son Co., retailers, is circulating a petition against this bill. His petition, he says, has been signed by about 25 retail jewelers, and Mr. Roberts asserts that he secured the names to the petition in about an hour. The subject is being generally discussed by jewelers here, and there are many expressions for and against the proposition.

The City Hall Site Commission, of which Joseph C. Wasson, manager of the jewelry department of the Jos. Horne Co., is chairman, last week made a report to Mayor George W. Guthrie favoring the selection of the Market house site for the proposed \$4,000,000 city hall. Should councils decide to abide by the decision of the commission this well mean that a number of jewelry concerns will be compelled to seek new quarters, for it is proposed to buy the property bounded by Fifth Ave., Union St., Masters Way and N. Diamond St., in order to give the hall a Fifth Ave. entrance. The firms of J. C. Grogan & Co., J. R. Reed & Co., John M. Roberts & Sons Co. and J. Schmidt are within this territory.

Application for a charter has been filed by the Pittsburg Association of Optometrists, and it is expected to be granted within a few weeks. This organization takes the place of the Pittsburg Association of Opticians. The incorporators are Dr. J. T. Little, Wm. T. McConnell, J. H. Connair, Harry W. Ewelt and Wm. H. Vogelsang. It has for its object the advancement of the science of optics and the attainment of a higher and practical scientific knowledge of its members. It also aims to discourage the indiscriminate sale of spectacles by irresponsible and incompetent persons and to protect members from harmful practices of the profession. It will especially look after legislation affecting the interests of the profession. The association has about 45 members. The incorporators named in the application for a charter are also the board of directors. Headquarters have been opened in the Wabash building, and meetings will be held the third Tuesday of each month.

Lancaster, Pa.

Paul Hilbert, Raleigh, N. C., visited Lancaster friends last week.

Joseph Zacks, Steelton, visited Lancaster and Philadelphia last week.

H. G. Pinkerton and Bernard Stubbs, Manheim, spent several days last week in New York.

Harry Sobel has been engaged for another year by the County Commissioners to attend to the Court House clock.

Edward Breneman, with Clayton Breneman, Altoona, has entered the Ezra F. Bowman Technical School as a student in watchmaking.

Wendell D. Swartz, of Leighton, Pa., has purchased F. H. Barndt's jewelry store at Birdsboro, the late owner engaging in another business.

John B. Rofh, Jr., has just finished a set

of solid gold oratorical contest medals for the Melrose, Pa., High School. They are beautifully enameled.

G. William Reiser has just finished 19 sets of fine gold, silver and bronze medals, prizes for the annual interscholastic athletic events at Tome Institute, Port Deposit, Md.

Among the jewelers who lately visited Lancaster were E. P. Zane, Christiana, Pa.; I. I. Cohn, York, Pa.; S. H. Miller, Mt. Joy, Pa.; Fred Paulsen, Pittsburg; Jere. P. Finger, Baltimore; Seth T. Alwein, Boston.

Harry Lichtenstein, late of Williamsport, and formerly a jeweler of Lebanon, Pa., has engaged in the jewelry business at Coatesville, occupying Mr. Dewald's old stand, Mr. Dewald retiring on account of his impaired eyesight. Mr. Lichtenstein is a brother of Benjamin Lichtenstein, this city.

Miss Emma Single, an employe of a watch factory at Waltham, Mass., who was found drowned there in the river on April 6, was a native of Lancaster, and formerly was employed in the watch factory here. It is believed she had been mentally unbalanced lately. Her body was brought here for burial.

Mrs. Anna Key M. Palmer, of Pittsburg, formerly of Lancaster, a descendant of Francis Scott Key, author of the "Star Spangled Banner," has presented to St. James' Episcopal Church, Lancaster, a pair of artistic brass hymn boards, designed and made by Lamb, of New York, as a memorial to her mother.

W. C. Cook, of the Howard Watch Co., Waltham, Mass., paid a visit last week to the Non-Retailing Co., stopping over on a trip west. C. E. Foose, a traveling representative of the Non-Retailing Co., is visiting the trade in the Pennsylvania coal regions, and another representative, F. A. Wheeler, has gone to Detroit, Mich.

Augustus Rhoads recently mounted a cane for J. A. Sprenger, of this city, the wood of which was from an oak planted by Mr. Sprenger in 1854. The head, of solid gold, taking 60 pennyweights to work with, and 37 pennyweights when finished, was beautifully inscribed. Mr. Rhoads has just celebrated the 40th anniversary of his start in business. His stores have been at Nos. 3, 13 and 20 E. King St., at the latter place since 1880.

The spectacle fraud was abroad again in Lancaster last week, and at a North Duke St. residence, Thursday, sold to an old lady two pairs of glasses for \$50 that were worth only \$2.50 each. The fellow, who claimed to be Dr. H. A. Gross, a Philadelphia specialist, was given \$30 cash and a check for \$20, which he raised to \$30 and had cashed at the Lancaster County National Bank. Chief of Police Bushong was notified of the transaction next day, but the "doctor" had disappeared.

R. M. Culver, Wellsboro, Pa., is moving his store from the Converse Block into newly furnished premises near the Tioga County Savings & Trust Co. building, on Walnut St.

The Derby Jewelry Co. was recently incorporated in Concord, N. H., with a capital of \$20,000. The incorporators are James C. Derby, W. L. Fickett, E. W. Conch, W. L. Stevens and H. W. Stevens.

"ASK YOUR JOBBER"



THE UP-TO-DATENESS OF THE
UR RINGS IS AGAIN PROVED
BY A COMPLETE LINE OF CAMEO
GOODS WITH HAND-PIERCED AND
SOLID SHANKS IN AN ENDLESS
VARIETY.

The Untermeyer-Robbins Co.

Seventy-One Nassau Street, New York

Patent
Process
Steel
Stamping

DIES



Write to-day

Could your die costs increase
50% without reducing profits?



Or, could they decrease 50%
without your reaping the benefit?

We want you to try one of our Dies at our risk,
and see for yourself how much we can save you.

JANITSCHKE COMPANY, INC.

33 UNION SQUARE

NEW YORK

Canada Notes.

Robert Chisholm has purchased the business of A. M. Woolnough, Niagara Falls, Ont.

The assets of Theodore Samson, Yama-chiche, Que., who recently assigned, are to be sold.

Frank Pyman, Enderby, B. C., has sold his jewelry business and is removing from that town.

A meeting of the creditors of Brasnick & Weinrobe, Vancouver, who are in financial difficulties, was recently held.

Out-of-town jewelers calling on the Toronto, Ont., trade, last week, included: A. E. Bywater, Trenton; W. H. Hopper, Cobourg; A. R. Harrison, Pembroke; R. M. Bell, Erin, and R. Robertson, Hagersville, all Ontario.

H. B. Kent, of B. & H. B. Kent, Toronto, Ont., will leave, Thursday, April 16, on a buying trip to New York and the eastern markets. He will stop at the Waldorf-Astoria. Before returning to Canada he will visit Atlantic City.

Samuel Finkle, manufacturing jeweler, Toronto, Ont., who, after a trial lasting four days, was found guilty of attempting to defraud the London Assurance Corporation by a false claim for loss by a fire at his place of business, which occurred under suspicious circumstances, was sentenced recently to one year's imprisonment.

W. K. McNaught, manager of the American Watch Case Co., and representative of North Toronto in the Ontario Legislature, has taken a very active and prominent part in connection with the proceedings of that body. Among other useful measures he has procured the passage of a bread law regulating the weight and stamping of bread. It is regarded as probable that before long he will be honored by the offer of a cabinet position.

On the afternoon of Friday, April 3, a thief entered the jewelry store of Max Finberg, 388 Yonge St., Toronto, Ont., Mr. Finberg being absent. Finding Mrs. Finberg alone in the store the intruder attacked her with a revolver and forced her into a room back of the store, where he knocked her down with the weapon. A servant hearing the noise began to scream, and Mrs. Finberg, calling loudly for help, the assailant became alarmed and ran out of the store without taking anything. Mrs. Finberg was badly bruised.

B. A. Griffith's jewelry store, Hagersville, Ont., was entered Friday morning, April 3, by burglars, who broke or cut the front window and a large quantity of the better class of goods, including gold watches, rings and pins, were stolen. The loss is estimated at about \$1,500. Mr. Griffith lives over the store, but heard no noise during the night. Suspicion attached to two unknown men who called at the store on the previous day and tried to trade a valuable watch. They appeared to be foreigners. On Friday, April 3, a man was arrested at St. Thomas on the arrival of train from the east on suspicion of being concerned in the robbery. He claimed to be Charles Spencer, of Detroit. No money or jewels were found in his possession. A companion escaped before the police could secure him.

Connecticut.

Charles H. Shaw, of the Silver City Cut Glass Co., Meriden, and Miss F. E. Blackmar were united in marriage on Wednesday.

President Lee Roberts, of the Bristol Business Men's Association, received an invitation to attend the annual banquet of the Hartford Association, April 19.

Edward P. Root, of the New Haven Clock Co., New Haven, returned last week from a two months' sojourn in Augusta, Ga., where he went on a pleasure trip.

George H. Barnum, formally identified with the jewelry trade in Norwalk and well known in the business for the last 17 years, has taken a position with A. W. Austin, of Wall St., Norwalk.

Mrs. David Schweitzer, widow of the jeweler of that name, was overcome by gas one night recently at her home, 13 E. Main St., Bridgeport, but was saved by the prompt arrival of a physician.

Abraham Fowler, a well-known traveling representative, died recently at the Bridgeport Hospital, after an illness of eight days, of cerebral hemorrhage. Mr. Fowler was 59 years of age. He is survived by a widow and four sons.

The Summer cottage of Samuel H. Kirby, at Silver Lane, was broken into and robbed, April 6, by two burglars, who escaped with a large amount of plunder. The intruders slept and dined in the cottage prior to departing.

Col. Irving H. Chase, E. H. Williams and Kellogg Blume, of Waterbury, have finished an extended trip in the south, including Jamaica and Nassau. Messrs. Chase and Williams are in New York, but Mr. Blume reached home Saturday night.

Henry Nerault, for some time employed as a burnisher by R. Wallace & Sons Mfg. Co., Wallingford, died in Meriden, Wednesday. Several beautiful floral offerings were conspicuous at the funeral. The fellow employes of the hand burnishing room attended in a body.

Among those who took part in the exercises attending the closing of the Fifth Ave. Hotel, New York, were N. L. Bradley, of the Bradley & Hubbard Mfg. Co., Meriden, and his wife. Mr. and Mrs. Bradley stopped at the old hostelry on their honeymoon trip, and have ever afterwards been guests there on their visits to the metropolis.

Mr. Rees, paymaster for the Charles Parker Co., and Mr. Morrell, also with the same concern, and Maj. William H. Lyon, manager of the Parker Co., are among the incorporators of a new manufacturing industry in Meriden for the manufacture of novelties of silver, brass, etc. The capital stock is \$10,000, of which \$6,000 has been paid in. The new concern is known as the Remo Mfg. Co.

The Barbour-Higbee Co. has closed its factory in Brooklyn, N. Y., and moved to Meriden, where the business will be continued in consolidation with the Barbour Silver Co. Wm. H. Barbour, brother of President S. S. Barbour, of the Barbour Silver Co., has been at the head of the Brooklyn concern and will also have charge of the business in Meriden.

The stockholders of the International Silver Co., at the annual meeting held recently, re-elected the old board of officers as fol-

lows: President, George H. Wilcox, Meriden; first vice-president, George C. Edwards, Bridgeport; second vice-president; C. A. Hamilton, New York; third vice-president, C. A. Tibbits, Wallingford; treasurer, George M. Curtis, Meriden; secretary, George Rockwell, Waterbury.

President Foster E. Harvey, of the Hartford Business Men's Association, appointed a committee of 12 to consider the advisability of closing stores Saturday afternoons during July and August, as proposed at the last meeting of the organization. One member of the committee was Charles R. Hansel, a well-known jeweler of Hartford. After some discussion the committee decided to recommend a half-holiday on Saturday, but only during the month of August. Heretofore the half-holiday has been on Friday.

A verdict in favor of George C. Edwards, of the International Silver Co., Bridgeport, was rendered in the Superior Court, at that place, Wednesday afternoon. Mr. Edwards had been made the defendant in a suit brought against him by the Sipple Adjusting Co., of St. Louis, Mo., to recover on three notes aggregating \$20,000. Mr. Edwards was congratulated on his victory by a number of friends in the court room. The notes upon which Mr. Edwards was sued were given by the American Electrical Co., of St. Louis, Mr. Edwards being one of the indorsers. He claimed that he gave his indorsement with the understanding that he was not to be held liable. It was also held that the plaintiff concern was not the bona fide owner of the notes, but simply a collecting agency.

North Attleboro.

Mr. and Mrs. G. Herbert French are home from the south.

George K. Webster has returned from a month's stay in the south.

Theron I. Smith and wife have returned from a two weeks' stay in Florida.

Mr. Angell, western representative of George L. Paine Co., was at the factory this week.

Checks for the first dividend of 60 per cent. from the Jewelers' National Bank were distributed Thursday.

Woodbury Melcher will temporarily cover the western circuit for Scofield, Melcher & Scofield. This is made necessary by the recent death of Harry Scofield.

Fred S. Gilbert has been chosen chairman of the Republican town committee. Walter B. Ballou, of R. Blackinton & Co., has been elected to fill a vacancy on the committee.

Edmund Cargill, formerly of North Attleboro, has taken charge of the E. B. Kingman Co., New York office. Mr. Cargill has had the New England district for several years.

Resolutions on the death of Charles E. Bliss, a retired manufacturer of Attleboro, were adopted on Friday by the trustees of the Attleboro Savings Bank of North Attleboro. Mr. Bliss was a potent factor in the development of the local bank.

Arthur C. Sylvester has acquired an interest in the United Brush Co., which is soon to move from Plainville to Pawtucket, where a large factory is in process of building. Mr. Sylvester was formerly superin-

tendent for G. K. Webster & Co. and the George W. Parks Co.

Artner B. Chace, who for many years has covered the western circuit for Fred S. Gilbert, has resigned. Mr. Chace will cover the same territory for Mandalien & Hawkins, whose specialty is chain purses, and will make his initial trip about May 1. Larger quarters have been secured by this firm in the Manufacturers' building.

Henry H. Curtis, treasurer of the H. H. Curtis Co., has submitted the following annual report to the Commissioner of Corporations: Machinery, \$36,125; cash and debts receivable, \$35,326; merchandise, \$25,824; patent rights, \$1,000; trade-marks, \$400; total, \$98,675; capital stock, \$75,000; accounts payable, \$21,335; profit and loss, \$2,340; total, \$98,675.

Attleboro.

Charles Perry, salesman for the Chas. M. Robbins Co., has returned from a lengthy western trip.

William H. Smith, who, last week, retired from Smith & Crosby, has returned from a visit with relatives in New York.

Peter Nerney, head of the Bay State Optical Co., returned last week from an extended trip about Jamaica and Panama.

Edward A. Wales, retailer, last week, represented the Attleboro branch of the American Benefit Society at the supreme convention.

Charles H. Tappan, of the D. F. Briggs Co., last week, made the Attleboro Gentlemen's Driving Club a present of a grand stand, judges' stand and other accommodations for its speedway.

The Odd Fellows' Building Association, last week, elected to various offices Hon. S. O. Bigney, of S. O. Bigney & Co.; Albert S. Ingraham, of A. S. Ingraham & Co.; Fred L. Torrey, of F. L. Torrey & Son.

Charles M. Robbins, of the Chas. M. Robbins Co., is diligently pursuing his campaign to go to Congress from the 14th Massachusetts district. Saturday night he gave a dinner party to district leaders and advanced his interests materially.

B. S. Sanfelder, for many years Chicago representative of McRae & Keeler, has severed his connections with that firm. He will be succeeded by C. E. Sutton, formerly with Marden & Kettley, of Providence. Mr. Sanfelder had been with the local firm nearly 15 years.

The Masonic Royal Arch Chapter, last week, elected to office William A. Spier, manufacturer; David E. Makepeace, of the D. E. Makepeace Co.; George H. Herrick, of George H. Herrick Co.; Winthrop F. Barden, of Barden & Hull; Charles L. Barrows and William F. Maintien.

The Watson & Newell Co., through Treasurer Clarence L. Watson, last week, filed with the Secretary of State the following annual corporation report: Real estate, \$34,666; cash and debts receivable, \$298,557; manufactures and merchandise, \$166,300; capital stock, \$450,000; accounts payable, \$2,597; profit and loss, \$46,926.

E. H. Bazzett, of the Pacific Coast China Co., is promoting the establishment of a cut glass factory with a capital of \$35,000 in Snohomish, Wash.

GORHAM LEATHER GOODS

EASTERTIDE

In view of the fact that Eastertide signalizes the approach of the Summer travel-season, and that advantage is increasingly taken of this by the purchasers of Easter gifts, the Gorham Company calls attention to the variety of traveling necessities offered by its Leather Goods Department.

The assortment of desirable and attractive articles is unusually complete, including such minor specialties as Traveling Jewel Cases, compact Shaving and Toilet Rolls, and the convenient Cigar Magazine holding from 50 to 100 cigars.

Of Traveling Bags a very full line is offered in all suitable leathers, and fitted in the simplest as well as the most elaborate fashion. Kit Bags, from the dainty size designed for women's use to the 26-inch size for men, as also Suit Cases for either sex, both fitted and unfitted.

THE GORHAM COMPANY,



CHICAGO,
137 Wabash Ave.

Silversmiths and Goldsmiths

Fifth Avenue and 36th Street, New York.

BRANCHES:

NEW YORK,
23 Maiden Lane.

SAN FRANCISCO,
Temporary Office:
1103 Broadway, Oakland, Cal.

LONDON,
Ely Place.



WORKS: Providence and New York.

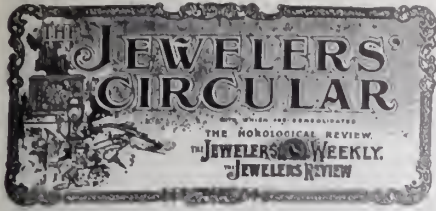

PUBLISHED EVERY WEDNESDAY BY THE JEWELERS' CIRCULAR PUB'G CO. L. J. Mulford, Pres. & Treas. V. S. Mulford, V. P. & Sec. 11 JOHN ST., COR BROADWAY, NEW YORK. TELEPHONE: 1148 CORTLANDT. CABLE ADDRESS: JEWELAR, NEW YORK.

VOL. LVI. APRIL 15, 1908. No. 11.

Subscription in United States and Mexico, \$2.00 Dominion of Canada, 3.00 Other Countries in Postal Union, 6.00 Single Copies, .10

Remit by check or money order. Remittances in money are at sender's risk.

Index to News and Special Articles.

Table with 2 columns: Article Title and Page. Includes entries like 'Bronze Lectern Presented by President Roosevelt to Bruton Parish Church', 'Royal Cramp Rings', 'Amber and the Amber Industry', etc.

The Daily Press and FORTUNATELY the Diamond trade for the jewelry Market. turned as far as the treatment of the diamond situation by the newspapers is concerned, for the leading journals of the country have now not only ceased to publish erroneous reports about the diamond market, but have in the past week or so been publishing authentic statements as to the situation, most of which have been inspired by members of the jewelry trade.

A very able editorial on the subject appeared in a recent issue of the Atlanta Constitution, one of the leading papers of the South, which began by warning those who were holding off their purchases of diamonds, in the belief that they would get them cheaper, to wake up from their pleasant dreams, as the yellow journals had been "stringing" their readers in regard to the situation.

Yet, upon this foundation, the wildest and most hysterical rumors have circulated throughout America. Lurid stories to the effect that diamonds would soon become a drug on the market; that anyone could soon afford them for breakfast, dinner and supper, and that a method has been discovered in France whereby diamonds were created out of nothing, have come into being and caused a good many people to postpone their purchases under misapprehensions somewhat ludicrous.

As a matter of fact, these dominating diamond producing factors have agreed to maintain the price of diamonds, whether or not the same syndicate handles their output, the indications are that there will be another hitch in prices about the 1st of July, and the crafty Parisian gentleman, who advertises his ability to manufacture diamonds while you wait, has had his fallacy exploded, and is under arrest, charged with swindling.

Always a stable commodity, always defying the fluctuations of the money market, virtually a world-recognized medium of fixed-value exchange, the stone we all admire—most of us, from a distance—will continue to look down at us from the battlements of a good, stiff price.

Another important editorial under the head of "Diamonds Not Declining" appeared in the Atlanta Georgian a few days previously, while important articles on the same subject have appeared in the Washington, D. C., Post; Toronto, Can., Mail and Empire; Bath, Me., Times; Leadville, Colo., Herald-Democrat; St. Paul, Minn., News; Waterbury, Conn., American; Washington, D. C., Star; Seattle, Wash., Post-Intelligencer; Anaconda, Mont., Standard; Winnipeg, Man., Free Press; Buffalo, N. Y., Express; Rochester, N. Y., Democrat and Chronicle; Massillon, O., Independent; New Orleans, La., World; Louisville, Ky., Times; Louisville, Ky., Post; Milwaukee, Wis., Sentinel; Geneva, N. Y., Times; Little Rock, Ark., Gazette; Baltimore, Md., American; Memphis, Tenn., Commercial Appeal; Wheeling, W. Va., Register; Springfield,

To insure publication all changes of copy for standing advertisements must be received not later than Friday noon preceding date of issue.

Mass., Republican; Minneapolis, Minn., Tribune; Milwaukee, Wis., Wisconsin; Syracuse, N. Y., Post Standard; Meriden, Conn., Journal; Ithaca, N. Y., Journal; Albany, N. Y., Times Union; Poughkeepsie, N. Y., Eagle; Grand Rapids, Mich., Herald; Ansonia, Conn., Sentinel; Bay City, Mich., Tribune; Middletown, N. Y., Press; Springfield, Ill., News; Detroit, Mich., News; Dayton, O., Herald; Victoria, B. C., Times, and a host of others, including a large number of papers who have published letters and interviews with members of the trade. The articles and editorials of THE CIRCULAR-WEEKLY have been most freely copied, as has also the letter sent out by the Jewelers Board of Trade.

There is no doubt now that a great deal of the effect of the first newspaper reports as to a break in the diamond market is now being counteracted in the minds of the public, and the jewelers' customers will soon begin to realize again, if they have not already done so, that diamonds are a staple product and in many instances a profitable investment.

Failures During the First Quarter.

THE statistics of the failures in the jewelry and clock trade for the first quarter of this year, made public last week by R. G. Dun & Co. show that the total number of failures and amount of liabilities in the jewelry trade is as high correspondingly as in other lines of business, though the figures during March alone are not as large proportionately. According to this authority, there were 125 insolvencies in the jewelry trade during the first quarter of the year, and the liabilities of all were \$2,474,735, as against 70 in 1907, with liabilities of \$650,734; 64 in 1906, with liabilities of \$652,631; 84 in 1905, with liabilities of \$654,156, and 84 in 1904, with liabilities of \$792,674.

The figures for the month of March alone show 32 failures this year with liabilities of \$653,035, as against 19 in 1907, with liabilities of \$148,651; 15 in 1906, with liabilities of \$262,522; 25 in 1905, with liabilities of \$229,053; 14 in 1904, with liabilities of \$104,238.

While the figures are large in comparison to previous years, considering the condition of business this year as compared with the usual prosperity enjoyed in the corresponding time of 1907, there is nothing in them that would disclose any special weakness in the trade, despite the severe trial it has undergone.

John C. Marx, Shakopee, Minn., will close out his stock of jewelry and leave for Washington about June 1.

A Profitable Investment for You

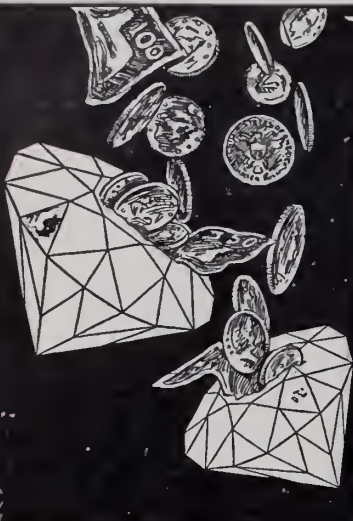

Put your money

and get your customers to put their money in
DIAMONDS
no better investment to-day.

The Jewelers Board of Trade announced recently that cable despatches received here from London said that the De Beers and Premier Diamond Mining Companies, controlling 97 per cent. of all the diamonds mined, had made a contract in which they agreed that there shall not be the slightest reduction from the present prices of diamonds.

We have a large stock of
DIAMONDS
on which we will make very
LOW PRICES
that cannot be duplicated when present stock is sold. We import the stones direct and sell them as close as anybody in the country does for
DIAMONDS
of equal quality. We carry a large stock, Loose and Mounted, and the jeweler who sends us for a selection not only gets
LOW PRICES
but also a liberal assortment and what is of utmost importance, he gets it promptly. Send us your orders.

V. WARING, N.Y.

CROSS & BEGUELIN

Importers and Cutters of Diamonds and Precious Stones

43 Rue de Meslay, PARIS

Telephone,
480 John

31 Maiden Lane, NEW YORK



Trade-Mark

OUR guiding principle has always been to incorporate as much artistic skill and good material in the construction of our jewelry as possible. This is contrary to the skimming, economic operations so extensively practiced in the manufacture of inexpensive gold jewelry. In observing this standard we naturally sacrifice the petty profits resulting from the less exacting methods of others; nevertheless our jewelry is consistently low priced and of a quality away beyond the ordinary.

Ask to see it and look for our trade-mark—the imprint of originality and all that's good.

85 Sprague Street
PROVIDENCE, R.I.

H. A. KIRBY

9-11-13 Maiden Lane
NEW YORK CITY

Rochester.

Joseph Kopelowich returned last week from a short southern trip.

A son was born to Mr. and Mrs. Bertram Moll, April 3, and Mr. Moll is receiving the congratulations of his many friends in the trade.

George Rice, arrested with Charles Boehler, on a charge of receiving stolen property, was discharged in police court last week as the grand jury found no indictment against him. Boehler was charged with breaking into S. D. Burritt's jewelry store, March 6. Boehler's case came up this week, and Judge Stevens suspended sentence until later. Boehler pleaded that necessity drove him to commit the crime. His record will be investigated.

An 80-foot clock and observation tower is being erected on the Bausch & Lomb Optical Co.'s factory, the structure to be of steel overlaid with copper, and fireproof. On the four sides of the tower eight-foot dials of an electric clock will be placed and bells will ring the hours. From the sidewalk the tower will be 145 feet high. This tower will also be used for the testing of distance lenses, used in the manufacture of field glasses and telescopes.

Blagio Izzo, who it is alleged disappeared from this city with \$600 worth of jewelry belonging to Henry Sloane, a jeweler at 122 Clinton Ave., North, was brought back from New York last week. Izzo was arrested by the New York police upon request of the Rochester officials. Izzo worked as an agent for Sloane and disappeared about three weeks ago with an assortment of goods which included watches of various styles and make. Among other things recovered from Izzo were pawn tickets calling for 20 watches also a number of gold bracelets, watch chains, broches, pins and cuff buttons.

Louisville, Ky.

A report from Williamsport stated that burglars broke into the shop of W. Baker early this month and carried away several hundred dollars' worth of jewelry.

Detectives are still endeavoring to discover the thieves who recently robbed the members of the family of Leonard Huber of jewelry worth about \$1,000. Mr. Huber is the junior member of the firm of Huber & Son, 356 Jefferson St., and the robbery took place at his home, Birchwood Crescent Hill. The burglars who committed the theft while in the house assaulted Mr. Huber and at the point of their revolvers forced silence upon the jeweler and his wife, while they ransacked the room. They searched everything, even the bed. Mr. and Mrs. Huber were lying. They got away with all the available jewelry, but left the silverware.

The Sunbury (Pa.) Board of Trade is raising a fund of \$100,000 to secure desirable industries.

The Auburn Music & Jewelry Co., Auburn, Nebr., has increased its paid-up capital stock to \$10,000. J. F. Cole has purchased an interest, and a branch store will be established in Humboldt, Nebr., under the management of Chas. Goddard.

New York Notes.

B. J. Sussman, diamond setter, has moved from 19 Beekman St. to 106 Fulton St.

W. S. Metcalf, of the Plainville Stock Co., has been spending a few days in town.

Sig. Strauss, of Lindenberg, Strauss & Co., Cincinnati, O., was in town during the past week.

Geo. H. Rosenblatt, 229 Broadway, returned from Europe last week on the *Kronprinzessin Cecilie*.

Wendell & Co. will remove May 1 from 103 William St. to the 12th floor of the new building at 45 John St.

The Manchester Mfg. Co., 13 Maiden Lane, has rented and will occupy larger offices on the 13th floor in the same building.

Jno. F. Turner, jewelers' auctioneer, April 3, closed an eight days' sale of stock, safe and fixtures of E. W. Parker, Battle Creek, Mich.

The E. Howard Clock Co., 41 Maiden Lane, has moved to new offices in the Royal Insurance Co. building, Maiden Lane and William St.

Garraud & Griser, lapidaries, seal and cameo engravers and importers of precious stones, will remove from 68 Nassau St. to 45 John St., about April 15.

F. I. Anthony, Comanche, Ia., has returned to this city from Europe on the *St. Paul*. He found the market for American pearls and baroques dull.

Ling & Stewart, 68 West Broadway, have become representatives in this city for Basaltine ware, manufactured by Frank Beardmore & Co., Fenton, England.

Albert Ginzberg, representing Eliassof Bros. & Co., 13 Maiden Lane, sailed Tuesday of last week on the *Pretoria* for Germany, where he expects to visit his parents.

Ford & Carpenter, manufacturing jewelers, whose office is now at 170 Broadway, will remove to larger and brighter quarters on the 17th floor of 15 Maiden Lane about May 15.

C. Ray Randall & Co. will move their New York office from the fourth floor, 7 Maiden Lane, to larger and more commodious quarters on the sixth floor of the same building, May 1.

Kleinberg & Probststein, diamond importers, have moved from 65 Nassau St. to more commodious quarters at 71 Nassau St. They have added a cutting and polishing department to their business.

The Luminous Silver Polish Co. has been incorporated under the laws of New York State, with a capital of \$1,000. The directors are: W. M. Parke, Brooklyn; Royer A. Heisler and Charles F. Lark, New York.

The L. Witsenhausen Co. will be represented on the road by T. A. Brennan, E. Weber, L. G. Seting, Jr., and L. Witsenhausen. The corporation succeeds the business formerly conducted by L. Witsenhausen.

The Fulton Watch, Cloak & Jewelry Co. has been incorporated under the laws of the State of New York, with a capital of \$5,000. The directors are Robert Schwerter, Julius Bottstein and Lester S. Abberley, all of this city.

Oppenheimer Bros. & Veith, 65 Nassau

St., have rented roomy quarters in the new Frankel building, and are about to move to the new address at 45 John St. The factory formerly located in Brooklyn will be moved to the new quarters.

Ira Grinberg, of A. J. Grinberg & Son, 152 Fifth Ave., has just recovered from an operation for appendicitis. The room which he vacated at Mt. Sinai Hospital is now occupied by Maurice Brower, who has just undergone a similar operation.

Robt. H. Ingersoll & Bro. have begun moving from 51 Maiden Lane to the Frankel building, 45 John St., where they will occupy the whole of the sixth floor. The new quarters will afford them much more room. The rooms are all well lighted.

J. H. Sutcliffe, editor of the *Dioptric Review*, London, Eng., and E. Culver, of George Culver, Ltd., wholesale manufacturing opticians, London, who have spent several weeks in New York, Philadelphia and other cities, sailed Thursday last on the *Amerika*.

A meeting of creditors in the matter of Louis Halpert, formerly in business at 51 Maiden Lane, who filed a petition in bankruptcy some time ago, will be held before Referee Smith, April 20. At a recent meeting, held before the same referee, Mr. Halpert was instructed to file amended schedules.

The Merchants' Association of New York has just issued its 1908 year book. The book contains the annual report of the president, treasurer's statement, by-laws of the association and a list of the members. Several photographs of the interior of the association building are shown. A photograph of the building is shown as a front piece.

At the regular monthly meeting of the directors of the Jewelers Board of Trade, held Thursday, the following firms were formally admitted to membership in the board: Bannatyne Watch Co., Waterbury, Conn.; Fox Mfg. Co., New York; O. Gottlieb & Co., New York; Merrill Bros. Co., Newark; Henry Weidmann, Newark, N. J.; N. Wolff & Co., New York.

A meeting of creditors of David Kessler, 221 Henry St., against whom a petition in bankruptcy was filed some time ago, was held Friday morning before Referee Seaman Miller, 2 Rector St. Attorney G. A. Rogers, representing the creditors, stated that there were no funds to continue the examination in bankruptcy and that the matter had best be closed for the present. No testimony was taken.

Isidore Prager, Keyport, N. J., and Miss Pauline Lucatsher were married recently at the home of the bride's parents at 1685 First Ave. by the Rev. Mr. Hirschson, of Hoboken. A wedding reception and collation followed, after which Mr. and Mrs. Prager went to Keyport and immediately began housekeeping in the apartments over the jewelry store, which Mr. Prager had previously prepared for their occupancy.

The International Congress on Art Education, which is to meet in London next August, is under the patronage of a number of well-known men and women headed by H.R.H. the Princess of Wales. The American Committee is progressing rapidly with the preparation of the exhibition of art work done in the schools of the United

States. This will be shown at the Museum of Natural History in New York from May 13 to 16.

The National Society for the Promotion of Industrial Education has decided to organize State associations. At the meeting of the board of managers recently held in this city plans were perfected for establishing these branch societies in 38 States. This testifies to the rapid growth of the society, which held its first annual meeting in January of this year at Chicago. The society has established permanent headquarters at 546 Fifth Ave.

Adolph Duckleis, 1617 Fulton St., Brooklyn, reported to the police of the Gates Ave. station last Wednesday that about midnight some person threw a stone at his store, breaking a big plate glass window valued at \$40. The crash of the breaking glass brought him down from his bed, and he soon made an investigation to see if anything had been stolen. There was not a single article missing. Duckleis believes the act to be spite work on the part of some of his neighbors.

Biggio Izzo, alias Barney Palmer, 25 years old, was arrested last week in this city on a charge of grand larceny in the second degree. Izzo is accused of having run away with about \$600 worth of gold watches and other jewelry belonging to Henry Sloan, of 122 Clinton Ave., North, Rochester, N. Y. Izzo has been a resident of Rochester for several years. Some two weeks ago he engaged with Sloan as a salesman, and as such obtained an outfit consisting of 22 watches, a number of rings, etc. After getting the goods Izzo promptly disappeared, and Sloan complained to the police. The latter traced Izzo to New Haven, Conn., and thence to this city.

A letter commending the action of the Jewelers Security Alliance in the assistance recently rendered by that organization by sending out circulars in an attempt to locate a clever swindler was received this week. The letter was signed by S. Silverthorn & Sons, New Haven, Conn.; L. Simon, Brooklyn, N. Y.; J. D. Kingsberg, Springfield, Mass., and Aaron Paul, Troy, N. Y., and referred to a young swindler whose tricks have been chronicled in *THE CIRCULAR-WEEKLY* in the past month. The young man visited the above-named and other jewelers, first taking a brass automobile clock to them to be repaired and later having become acquainted attempted to obtain diamonds by fraudulent means.

A hearing on the involuntary bankruptcy proceedings against George H. Carpenter, with whom Maurice Dreshfield was associated in transactions by which \$182,549 worth of diamonds are alleged to have been obtained from R. A. Breidenbach, 51 Maiden Lane, was called before Special Master Peter B. Olney, 68 William St., last Friday, but on request of Cohen & Cohen, attorneys representing Mr. Dreshfield, the meeting was adjourned until tomorrow. The attorney said a settlement was under consideration and he wished more time. A previous examination in the Carpenter matter came up last Wednesday before Special Master Olney, at which time testimony was taken. Mr. Dreshfield was on the stand and questioned as to a meet-

(New York Notes continued on page 68.)

1851

The Jeweler's Bank for half a century
in the same location.

1908

THE CHATHAM NATIONAL BANK

Broadway and John Street, New York

ACCOUNTS INVITED

GEORGE M. HARD, President

WILLIAM H. STRAWN, Cashier

HENRY L. CADMUS, Assistant Cashier

Title Guarantee and Trust Company

176 Broadway (between John St. & Maiden Lane)
NEW YORK

Capital and Surplus, \$12,000,000 :: The Depositor's best guarantee is a large capital and surplus, together with conservative management

TRUSTEES

John Jacob Astor, 23 West 26th St., New York
 Frank Bailey, Vice-President
 E. T. Bedford, President Corn Products Refining Co.
 Charles S. Brown, of Douglas Robinson, Charles S. Brown & Co.
 Julien T. Davies, of Davies, Stone & Auerbach
 William M. Ingraham, Attorney-at-Law, 44 Court St., Brooklyn
 Augustus D. Juilliard, of A. D. Juilliard & Co.
 Martin Joost, Vice-President Bond & Mortgage Guarantee Co.
 Clarence H. Kelsey, President
 John S. Kennedy, Retired, 31 Nassau St., New York
 Woodbury Langdon, of Joy, Langdon & Co.
 James D. Lynch, Retired, 129 East 21st St., New York
 Ranald H. Macdonald, of R. H. Macdonald & Co., Real Estate
 James H. Manning, President National Savings Bank, Albany
 Edgar L. Marston, of Blair & Co.

Wm. J. Matheson, of W. J. Matheson & Co., 182 Front St.
 Charles Matlack, 70 State St., Boston
 William H. Nichols, Chairman of Board, General Chemical Co.
 William A. Nash, President Corn Exchange Bank
 Robert Olyphant, of Ward & Olyphant
 Charles A. Peabody, President Mutual Life Insurance Co.
 William H. Porter, President Chemical National Bank
 Frederick Potter, 71 Broadway, New York
 Charles Richardson, 1307 Spruce St., Philadelphia
 Henry Roth, 1562 Myrtle Ave., Brooklyn
 Jacob H. Schiff, of Kuhn, Loeb & Co.
 James Speyer, of Speyer & Co.
 Sanford H. Steele, of Steele, Otis & Hall, Attorneys
 Ellis D. Williams, 560 Drexel Bldg., Philadelphia
 Louis Windmuller, of Louis Windmuller & Roelker

BRANCH BANKING OFFICES: 196 Montague St. and 175 Remsen St., Brooklyn; 350 Fulton St., Jamaica; 67 Jackson Ave., Long Island City

The Market and Fulton National Bank of New York

ORGANIZED 1852

81-83 FULTON STREET

Capital, \$1,000,000

Surplus, \$1,500,000

PROGRESSIVE—CONSERVATIVE—SUCCESSFUL

ALEXANDER GILBERT, President
 R. A. PARKER, . . . Vice-President
 T. J. STEVENS, Cashier
 JOHN H. CARR, . . . Asst. Cashier

Invites the Accounts of Jewelers
 Will extend every facility that good banking will justify

SAFE DEPOSIT VAULTS

THE STATE BANK

376-378 GRAND STREET, NEW YORK

Capital and Earned Surplus, over \$1,500,000. Deposits over Fifteen Millions.

Offers a favorable market for short and long time jewelry and diamond paper.

The Mercantile National Bank

OF NEW YORK

WILLIS G. NASH, President

MILES M. O'BRIEN, Vice-President

WM. SKINNER, Vice-President

WILLIAM H. TAYLOR, Vice-President

EMIL KLEIN, Cashier

DIRECTORS

WILLIAM F. CARLTON,
ROBERT C. CLOWRY,
WILLIAM NELSON CROMWELL,
L. H. CUTTER,
EDWIN GOULD,
HAROLD A. HATCH,

EDWARD T. JEFFERY,
WILLIAM H. LAWS,
WILLIS G. NASH,
BENJAMIN NICOLL,
MILES M. O'BRIEN,
CHARLES E. PERKINS,

DICK S. RAMSAY,
WILLIAM SKINNER,
E. D. STREET,
WILLIAM H. TAYLOR,
E. J. TRUSSELL,
WARNER VAN NORDEN,

Strictly a Commercial Bank
Accounts Solicited

New York Notes.

(Continued from page 65.)

ing between himself and Carpenter at Haan's Restaurant on April 1. He said that he was there with Mr. Carpenter about half an hour, and was further questioned relative to the conversation at that time. He also testified that \$45,000 worth of diamonds were delivered on Dec. 16 and Dec. 21 to himself and Carpenter. A memorandum agreement between Mr. Breidenbach and Carpenter was submitted in evidence and placed on record.

Berland & Nadler have moved from 30 Chrystie St. to 47 and 49 Maiden Lane.

The business of Rundback Bros., 2196 Third Ave., is now known as "Rundbacks."

G. A. Henckel & Co. have moved from 540 W. 22d St. to new quarters at 109 W. 26th St.

Nathan Grunberg has succeeded to the business of Grunberg & Eisenstein, 146 Park Row.

Thomas W. Adams & Co., Ira Goddard, the Jewelers' Protective Union and Jewelers' Safety Fund Society will move from 11 John St. to the Silversmiths' building, 15 Maiden Lane, about May 1.

In the United States District Court, Monday, Judge Hough granted a discharge in bankruptcy to Edwin W. Dayton, jeweler, 44 W. 39th St., who lost \$48,000 by his transactions with J. Edward Boeck.

Samuel Finkelstein, 38 John St., who started in business for himself in April, 1907, died Sunday, April 5. He was employed by Max Kameras, 51 Maiden Lane, for eight years and was a practical chain maker.

The trustees in charge of the matter of E. M. Gattle & Co., Fifth Ave. and 38th St., announce the payment of the first dividend of 15 per cent. to the creditors of that concern. This payment will be made at the Bankers' Trust Co., 7 Wall St.

Owing to differences between the partners a temporary receiver of the business of Shiman & Eisenstein, 51 Maiden Lane, has been applied for. Mr. Shiman stated that he had served an injunction on his partner restraining him from taking anything out of the place, and the injunction carried a petition for the appointment of a temporary receiver.

John J. Desmond, president of the Townsend, Desmond & Voorhees Umbrella Co., 475 Broadway, committed suicide last Saturday at Newark, in the Tremont apartment house, by shooting himself in the head. He is said to have lost heavily in speculation recently, which unsettled his mind. Inglis M. Uppercu, a friend of Mr. Desmond, took charge of the body. Mr. Desmond was 40 years old and a native of California. He had no immediate family.

Louis Bloom, 654 Broadway, Brooklyn, stated to THE CIRCULAR-WEEKLY last week that he gave a three stone diamond ring on memorandum to a man named Lerner on March 26, and that he did not report for two weeks, at the end of which time the jeweler got out a warrant for his arrest. Mr. Bloom said that detectives caught the man Saturday night, April 4, in Brooklyn. At the hearing Lerner, according to the letter, admitted pawning the ring after he

told the judge that he took it for the purpose of having it tested. He was held for the grand jury.

John Swift Holbrook, vice-president of the Gorham Co., and Miss Grace Morgan Sinclair, daughter of John J. Sinclair, of 6 E. 63d St., were married at 4 o'clock last Saturday at the residence of the bride. The Rev. Dr. J. Douglas Adams officiated. The bride was given in marriage by her father. Her sister, Mrs. Irving E. Raymond, was the matron of honor. There were no bridesmaids. Percival Lombard, of Boston, cousin of the bridegroom, was best man, and the ushers were Stewart Woodford Eames, Irving E. Raymond, Frank Bicknell and Merritt Haviland, of New York, and James Harris, of Philadelphia.

Larter & Sons, 21 Maiden Lane, have not as yet received any information relative to the disappearance of a suit case containing \$3,000 worth of jewelry which was left in the subway train Monday of last week by a messenger. A city salesman had taken the case to a Fifth Ave. jewelry store to show samples, and having to go out of town, phoned to the office for a messenger to come after the sample case. The messenger came downtown in the subway, and on reaching Brooklyn Bridge he was reminded of an errand to do at that place, and rose hastily and left the train, forgetting all about the valuables in his keeping. No suspicion is attached to the messenger, as he has been in the firm's employ for some time. The case is described as a small, well-worn brown leather case, 15 inches long, nine inches high, and five inches wide; \$200 is offered for information leading to the recovery of the jewelry. The case contained jewelry in six black trays. In four of the trays were 38 complete men's sets. Each set was on a black velvet pad, and consisted of six vest buttons, 3 shirt studs and one pair of links, mounted in 14-karat gold and platinum, many of them mother-of-pearl with diamonds, whole pearls, half pearls, rubies, sapphires, etc. Others contained semi-precious stones, such as amethysts, moonstones, white carnelian and Chinese jade. One tray contained 33 pairs of diamond sleeve buttons, varying from 1/16 to 1/4 carat. The sixth tray contained 28 pairs of 14-karat gold sleeve buttons.

D. Wiesenberger, 33 Cooper Sq., reports that he was the victim of an old trick Thursday by which he lost a split second horse timer worth over \$100. The thief asked to see the watch and left, saying he would call again. He returned an hour later and had the watch shown him and then asked for a filled chain. When the jeweler turned to get the chain the man grabbed the watch, walked out of the store and put a stick through the handles so the jeweler would not get out and pursue him. The thief was about five feet seven inches high, had a light complexion and brown mustache. He speaks English and German. The matter has been reported to the police.

Burglars gained entrance to the store of J. A. Piccard, 1233 Fulton St., Brooklyn, early Sunday morning, and got away with silverware, rolled plate jewelry and a miscellaneous assortment of other articles valued at about \$1,000 by Jeweler Piccard.

Entrance to the store was gained through a rear window protected by iron bars, and it is the opinion of Mr. Piccard that there were at least two men connected with the robbery.

Newark.

Frederick T. Long, having purchased one-half interest of the business of Wm. I. Allsopp, the firm name will hereafter be Allsopp & Long.

P. Rubin, now at 17 Main St., Paterson, will move about May 1 to 31 Main St. Max Rubin, Baltimore, Md., is visiting his brother in Paterson.

Some damage was sustained by L. Fritzsche & Co., manufacturing jewelers, in the fire which broke out in a building at New Jersey Railroad Ave. and Hamilton St. last Friday morning. The jewelry firm has space on the third floor.

LeRoy C. Stark, at Perth Amboy, N. J., who located in the Parisen building on Augusta St., has moved into the building on Broadway formerly occupied by A. C. Parisen, and has sublet the Augusta St. store for the balance of his unexpired lease.

Robert Cornelies, 69 years old, said to be a jeweler, by trade, who boarded at 43 Somerset St., committed suicide, recently, by inhaling illuminating gas. According to Gustave Trautz, with whom he boarded, Cornelies had been out of work for about six weeks and had become despondent. He was a German.

An auction sale of jewelry, alleged to have been smuggled into this country by Jacob Lowensky, of New York, will be held in the postoffice here, April 24, by order of the Federal authorities. The jewelry consists of two diamond rings, a jeweled watch, a stick pin and two combs. The articles were seized by the officers in the custom house at Hoboken about two months ago.

A young man called, last week, at the store of Bernhard Sachs, of 122 Springfield Ave., and looked at some expensive scarf pins, but left without buying any of them. It developed a short time afterward that the prospective customer had not gone empty-handed, even though he spent no money. A diamond pin valued at \$15 was found to be missing. Sachs described his customer to the police.

Miss Marie B. Riker, daughter of Mr. and Mrs. Joseph M. Riker, was married to Franklin Conklin, Jr., in the South Park Presbyterian Church last Wednesday afternoon, Dr. Lynn Whitney Allen performing the ceremony. After the ceremony a reception was held at the residence of the bride's parents, 83 Lincoln Pl. Mr. and Mrs. Conklin have gone for an extended wedding tour. The bride is the daughter of Joseph M. Riker, of Riker Bros.

I. Kleinfeld, the jeweler at 84 Ellison St., Paterson, N. J., left his store one evening recently to go to dinner. On his return he found the large plate glass in his window had been cut a score of times with a diamond. Upon opening the store door the glass fell in many pieces. Mr. Kleinfeld has his window filled with jewelry and silverware. He believes that the person who cut the glass intended to return later in the night and steal the goods.

Bids Received and Contracts Awarded by Government Departments.

WASHINGTON, D. C., April 10.—The Purchasing Agent of the Isthmian Canal Commission has received the following proposals:

For one set minute beam compasses, complete: Eugene Dietzgen Co., \$11.10, delivery 30 days; Izard-Warren Co., Philadelphia, Pa., \$17.12, 15 days; Keuffel & Esser Co., Hoboken, N. J., \$13.01, 15 days; Keystone Co., Philadelphia, Pa., \$18.43, 30 days; Queen & Co., Philadelphia, Pa., \$18.58; Technical Supply Co., New York, \$11.89, shipment 15 days; F. Weber & Co., Philadelphia, Pa., \$14.26, 30 days.

For four dozen pocket magnifying glasses: Eugene Dietzgen, \$19, 30 days; Izard-Warren Co., \$18.10, 15 days; Keuffel & Esser Co., \$16.56, 15 days; Keystone Co., \$19, 30 days; Old Dominion Paper Co., Norfolk, Va., \$20.60, 30 days; Queen & Co., \$27.60; Technical Supply Co., \$13.80, shipment 15 days; F. Weber & Co., \$19.20, 30 days; J. H. Weil, Philadelphia, Pa., \$18.60, shipment 10 days; A. S. Aloe Co., St. Louis, \$17.60, shipment six days; H. E. Boucher Mfg. Co., New York, \$38.65, shipment six days.

WASHINGTON, D. C., April 11.—The Navy Department has awarded the following contracts:

For 6,000 forks and 6,000 spoons, Norfolk Navy Yard: Manhattan Supply Co., \$956.40.

For 6,000 table knives: A. B. Lovejoy, \$452.40.

Creditors Listed in the Bankruptcy Schedules of the Madson-Steele Co., Chicago.

CHICAGO, April 11.—The schedules in the bankruptcy of the Madson-Steele Co., a mail-order jewelry house, show the creditors to be as follows:

Less than \$50—Kreis & Hubbard, Western Watch Case Mfg. Co., J. T. Mauran Mfg. Co., Sturtevant & Whiting, S. Buchsbaum & Co., Geneva Optical Co., Swarteluld & Co., Providence Stock Co., D. G. Nessler, S. & B. Lederer Co., Harvey & Otis, F. & F. Fe'ger, Mercury Silver Co., Capron & Co., E. L. Logee & Co., S. K. Grove & Co.

From \$50 to \$100—Towle Mfg. Co., Geo. Kuehl & Co., B. A. Ballou & Co., Jeannette Jewelry Co., Paul E. Wirt, Attleboro Mfg. Co., Rochester Cut Glass Co., Darche Mfg. Co.

From \$100 to \$150—Wm. L. Gilbert Clock Co., New Haven Clock Co., Sykes & Strandberg, Barden & Hull, A. H. Bliss & Co., C. H. Allen & Co.

From \$150 to \$200—J. Bulova, Waite, Thresher Co., Watson & Newell Co., Attleboro Chain Co., Heinrich, Herman & Weiss, Wheeler Jewelry Co., Brown & M'Is.

From \$200 to \$250—C. R. Harris, C. O. Sweet & Son Co., Simons, Bro. & Co., Wm. A. Rogers, Ltd.; Potter & Buffinton Co., Geo. Becker & Co., S. O. Bigney & Co., G. C. Hudson & Co., Depasse Mfg. Co., J. M. Fischer & Co., J. J. White & Co., Doran, Bagnall & Co., N. Barstow & Co.

From \$250 to \$300—W. C. Greene & Co., Wolcott Mfg. Co., Schickerling Mfg. Co., G. A. Webster.

From \$300 to \$350—Manning, Bowman & Co., W. H. Bell Co., W. H. Saart Co., Schwartzkopf Mfg. Co., Van Bergh Silver Plate Co.

The largest creditors are International Silver Co., \$1,101; E. G. Webster & Son, \$954; R. Wallace & Sons Mfg. Co., \$6,202; Alvin Mfg. Co., \$992; A. Hirsch & Co., \$468; E. J. Koch & Co., \$1,026; Meriden Cutlery Co., \$918; Martin, Copeland & Co., \$542; S. Lazarus & Co., \$1,266; Quaker City Cut Glass Co., \$603; S. K. Huston, \$2,262; Despres, Bridges & Noel, \$822; W. B. Marble & Co., \$718; E. I. Franklin & Co., \$397; Bristol Mfg. Co., \$1,065; O. E. Weidlich & Co., \$576; Geo. L. Paine & Co., \$821; Geo. L. Brown & Co., \$397; Jennings Bros. Mfg. Co., \$390; E. L. Spencer & Co., \$849; L. Fritsche & Co., \$160; Bassett Jewelry Co., \$599; Fera & Kadison, \$2,277.

The schedules state that Martin Madson is a creditor for \$349 for merchandise sold to the corporation, and for \$1,200 for money loaned to the corporation.

Jewelers Burned Out in Conflagration Which Destroyed Part of Chelsea, Mass.

CHELSEA, Mass., April 12.—The fire which wiped out one-third of the city today swept through a large portion of the business section, and the following firms in the jewelry and kindred trades were burned out: Addison Bros., Samuel Fritz, Herman L. Goldberg & Son, John H. Howes, Nelson Bros., Isaac Wolper & Co.

The Chelsea Clock Co., whose plant is in the district near which the fire started, escaped the conflagration.

Death of Edgar D. Wood.

PROVIDENCE, R. I., April 10.—Death removed one of the pioneer enamellers and manufacturers of enameling stock last Wednesday in the person of Edgar B. Wood, who passed away at his home in Riverside. He was a member of the firm of Carpenter & Wood, and his death came after a protracted illness with Bright's disease.

Deceased became connected with the jewelry business in 1880, after he had made a tour of the world in the ship *Hades*. He became connected with the shops of Chester and Manchester as a toolmaker, and later opened a business of his own, making tools for various jewelry houses. In 1887 he entered the employ of A. L. Carpenter, and later became a member of the firm. In 1904 the senior member of the firm died and Mr. Wood had since conducted the business under the original firm name. He is survived by a widow and two married daughters.

LeRoy E. Cole has succeeded to the business of the J. H. Washburn Co., Natick, Mass., of which he has been manager for the past six years. Mr. Cole was formerly a student at the Waltham Horological School.

A new building is being erected in Wheeling, W. Va., for the use of Sheff Bros., retail jewelers of that place. The structure is being built on Market St., and will be one of the attractive buildings of that thoroughfare.



Traveling representatives in Los Angeles, Cal., recently, included: Oscar S. Schmidt, Moore & Son; Albert E. Lee; D. F. Carnes, J. Hoare & Co.; Zach. A. Oppenheimer; Herman Abrahams, S. Cohn & Co.

Lancaster, Pa., was visited, recently, by the following traveling representatives: Meyer Wolf, W. Green & Co.; Gus. Engelsman, Zach. A. Oppenheimer; R. V. Curran, F. W. Sackett; H. A. Platt, Rees & Yankauer; W. B. Ehlers, Ehlers & Co.; Mr. Connor, G. S. Lovell Clock Co.; H. C. Berdan, Gorham Co.

The following traveling representatives called on the trade in Kansas City, Mo., during the past week: E. A. Moore, Sykes & Strandberg; Frank E. Behrendt, Homan Mfg. Co.; Henry H. Jacobson, Jacobson Bros.; W. F. Adams, International Silver Co.; J. W. Carmichael, Bride & Tinckler; F. D. Newburger, Charles Keller & Co.

The following traveling representatives were in Cleveland, O., last week: F. S. Ottley, Riker Bros.; E. A. Reed, Reed & Barton; F. L. Wood, Ludwig Nissen & Co.; Mr. Adler, L. Adler & Co.; J. M. Morrow, American Watch Case Co.; Ed. Eckfeldt, Eckfeldt & Ackley; F. S. Barnum, Shafer & Douglas; Mr. Bliss, Gorham Co.; Mr. Hurd, W. S. Pitcairn.

Among the representatives of eastern houses in San Francisco, Cal., during the past week, were: Mr. Brown, Carter, Howe & Co.; O. F. Samuelson, Towle Mfg. Co.; Henry N. Jacobson, Jacobson Bros.; John O. Slemmons, J. B. Bowden & Co.; Mr. May r, Mauser Mfg. Co.; David Beer, Bernheim & Beer; F. H. Wilkinson, A. Wittnauer & Co.; L. A. Eppenstein, Eppenstein Co.; Mr. Lowenstein, D. Lisner & Co.

Traveling representatives who called on the trade in Omaha, Nebr., during the past week, included: Steve Leubirsher, L. Gutmann & Sons; Ira C. Jones, Chas. L. Trout & Co.; J. T. Carman, Meriden Cutlery Co.; Mr. Singleton, Adams & Singleton; C. H. Davison, Kohn & Co.; Mr. Adams, William B. Durgin Co.; Carl M. Fishel, Rice & Hochster; J. P. Coyle, Whiting Paper Co.; Carl H. Weidemann, Borrelli & Vitell; Henry H. Jacobson, Jacobson Bros.; J. H. Miller, Chester Billings & Son; R. L. Robinson, Dennison Mfg. Co.

Among the traveling representatives who were in Pittsburg, Pa., recently, were the following: H. H. Meyer, Wm. B. Kerr Co.; J. T. Griffith, Jr., Carter, Howe & Co.; L. H. Smith, Bippart, Griscom & Osborn; E. E. Stockton, E. Ingraham Co.; Charles T. Dougherty, Osmer-Dougherty Co.; L. E. Picard, American Watch Case Co.; J. E. DeWyngeart, Scofield & DeWyngeart; Arthur Bradshaw, Meriden Britannia Co.; A. E. Hayward, Seth Thomas Clock Co.; A. Rutherford, Gibson, Kueger Co.; Wm. F. Koch, American Morocco Case Co.; Frank S. Ottley, Riker Bros.; W. R. Eliot, Meriden Cut Glass Co.; Fred H. England, Frolichstein, England & Klein; L. M. Levy, Philadelphia Watch Case Co.; Arthur Totten, Sansbury & Nellis; G. W. Bleecker, Martin-Copeland Co.

Traveling representatives who called on the Cincinnati, O., trade, during the past week, included: M. H. Mason, James Blake Co.; Otto Sinnauer, L. & M. Kahn & Co.; William J. Harber, Enos Richardson & Co.; Mr. Smith, La Pierre Mfg. Co.; Edward L. Johnson, R. M. Johnson & Son; A. J. Parker, Osmun, Parker Mfg. Co.; Lester B. Smith, Dominick & Hafl; Walter R. Shute, Day, Clark & Co.; Walter S. Noon, Cory Bros. Co.; R. B. Carr, Link & Angell; W. H. Osborne, R. Wallace & Sons Mfg. Co.; W. Strauss, Jacob Strauss & Sons; J. T. Griffith, Jr., Carter, Howe & Co.; H. E. Barkman, Simpson, Hall, Miller & Co.; J. M. Curtis, Meriden Silver Plate Co.; L. H. Smith, Bippart, Griscom & Osborn; John J. Moffitt, Battin & Co.; M. Untermeyer, Charles Keller & Co.; Charles S. Williams, Landrs, Fray & Clark; C. T. McKenna, Kelly & Steinman, Inc.; Frank P. Steitz, William Link.

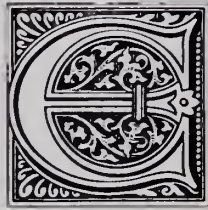

GNTERPRISING and successful jewelers everywhere are pushing the sale of some individual line of watches which they believe to be superior to all others, and upon which they can also make a satisfactory and justifiable profit.

This explains the growing demand for **ILLINOIS WATCHES**, in 0, 12, 16 and 18 sizes, by increasing numbers of leading jewelers throughout the United States.

If you are not familiar with the superior quality of—and advantages gained by handling—**Illinois Watches**, it will mean reputation and dollars for you to investigate.

Every one fully guaranteed.

Price List sent on application.

ILLINOIS WATCH COMPANY

SPRINGFIELD

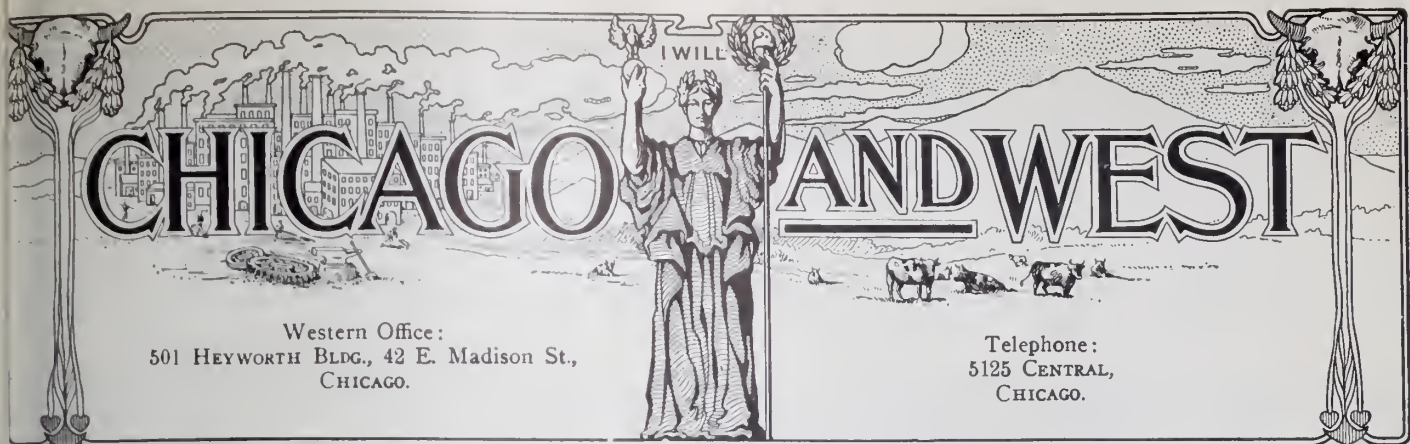

Western Office:
501 HEYWORTH BLDG., 42 E. Madison St.,
CHICAGO.

Telephone:
5125 CENTRAL,
CHICAGO.

Chicago Notes.

Maurice Wendell is here from New York.

Fred Hyatt, with the Philadelphia Watch Case Co., is on a western trip.

R. H. King, with the Ostby & Barton Co., is on a visit to the factory.

M. B. & H. H. Joseph are now settled in their new quarters, 42 Madison St.

Harry C. Ulmer, representing the Kryptok Sales Co., was here last week.

Mr. and Mrs. V. J. Young, Mount Sterling, Ill., were here all last week.

Frank E. Harmer, with the Solidarity Watch Case Co., was here last week.

W. Hankan, W. 24th St., contemplates opening a jewelry store in Gary, Ind.

In addition to his other lines Daniel Axman is representing the Central Cut Glass Co.

The offices of L. H. Schaefer & Co., in the Columbus building, have been remodeled.

P. Hermer, formerly jewelry buyer for Mandel Bros., is in southern Georgia for his health.

Herb. Crompton, buyer for the L. Bauman Jewelry Co., spent a few days here last week.

A slight fire on the premises occupied by C. G. Breitenbach & Co., last week, did no damage.

Chas. E. Howes, with E. L. Logee & Co., is at the factory on account of the death of Mr. Logee.

O. W. Wallis, W. M. Hathorn and C. J. Zeller have been appointed appraisers of the estate of Max Marcus.

A. M. Kinsley and R. A. McCowan, of the Oneida Community, Ltd., recently returned from Nashville, Tenn.

Simon Greenburg, 106 Clark St., jeweler and loan broker, is selling out preparatory to retiring from business.

Harry E. Farquharson, representing E. D. Gilmore & Co. and the E. A. Potter Co., is on a visit to these eastern factories.

The capital stock of Olsen & Ebann, instalment jewelers in the Republic building, has been increased from \$5,000 to \$15,000.

The Floyd-Horsman Co., Somerville, Mass., has opened an office in the Heyworth building in charge of W. S. Tompers.

L. J. Will, of Rahm & Will, Iron Mountain, Mich., was here last week. Mr. Will announces that a baby girl has been added to his family.

"Joe" Finn, diamond buyer for Loftis Bros. & Co., has returned from a flying trip to New York City, where he went on a purchasing trip.

Eugene Edelstein, representing the Illinois Watch Case Co., sailed for a three months' business trip to Europe, April 9, on the steamer *Amerika*.

Howard C. Carpenter, sales manager of the South Bend Watch Co., was here last week attending the meeting of the Illinois Retail Jewelers' Association.

News is received here that A. A. Thomas, son of Samuel M. Thomas, succeeded to his father's business, after the latter's death, at Tabor, Ia., recently.

Abe Franks has returned from New York, where he became interested in the 10 and 14 Karat Jewelry Mfg. Co., a corporation which succeeded to the firm of Kling & Baer.

A fire in the building in which is located the jewelry store of Forstrom Bros., 1717 N. Clark St., caused the stock of the latter to be damaged by water last week. The loss was fully covered by insurance.

John J. Devine, who recently retired from business in Salt Lake City, and who has since been living in Chicago with his wife, is going back to Salt Lake City to again enter the jewelry field.

M. Kahn, retail jeweler at 2108 W. 12th St., is closing out his stock at auction through Louis Byrens, jewelry auctioneer. The fixtures and show cases are for sale as Mr. Kahn intends retiring from the retail jewelry trade.

G. A. Webster, manufacturer of leather goods, will remove on May 1 from 64 Wabash Ave. to 100 Lake St., corner of Dearborn St. The new location will be larger than the old one and better adapted to the needs of the business.

The marriage of Oscar A. Lessing and Miss Belle Phillips took place on the evening of April 15, at the Hotel Metropole, this city. Mr. and Mrs. Lessing are now on a tour east. Mr. Lessing is the Ohio representative of the S. & B. Lederer Co.

Harry N. Hahn, of H. F. Hahn & Co., is "down on the farm" a few days each week. It is not known to many in the trade that Mr. Hahn owns a 40-acre farm and Summer home at Barrington. Mr. Hahn is superintending the Spring ploughing and is an enthusiast amateur farmer.

Mack A. Hurlbut, president, and Ira M. Radabough, secretary, of the American National Retail Jewelers' Association, stopped

over here long enough last Thursday to organize the Illinois Retail Jewelers' Association, and then went to Cincinnati on business for the coming national convention.

Louis Weill, of Weill & Co., London agents of the Omega Watch Co., stopped over a few hours here, last week, on his way to San Francisco, where he went on a special trip to see a child of his nephew. This is a long trip to take just to see a little baby, but Mr. Weill feels that the long journey will be well worth it.

F. G. Thearle, of the C. H. Knights-Thearle Co., left here last (Sunday) night for the east. Mr. Thearle will sail from New York on April 18 on the steamer *Republic* for Italy. Mr. Thearle will spend four months in a tour of Europe, and while absent will visit the diamond markets of Paris, London and Amsterdam.

Robert L. Clark, with the Towle Mfg. Co., has severed his connection with that concern. Mr. Clark traveled out of the Chicago office for the Towle company for the past five and a half years and was one of the most popular silverware salesmen in his territory, which included the northwest Missouri, Kansas, Nebraska and parts of Iowa and Wisconsin.

Among the out-of-town buyers here last week were: Fred. Overstreet, Paxton; A. Gulbrandson, Rockford; A. J. Munson, Alexis; J. B. Ingalls, Rock Island; J. T. Holmquist, Sycamore; Miss Grace E. Orendorf, Delavan; W. C. Reinmiller, Atlanta; O. B. Rystrom, with the Bauer Jewelry Co., Elgin; J. A. Rovelstad, Elgin; H. G. Weger, West Chicago; H. I. Thompson, Buda; W. O. Foley, Chicago Heights; A. F. Pierce, Milford; Lorenz Holland, Cullum; Frank Smith, Pontiac; W. A. Hammond, Bement; F. A. Marcan, Belvidere; V. J. Young, Mount Sterling, Ill.; Mark A. Hurlbut, Ft. Dodge, Ia.; I. M. Radabaugh, Hastings, Minn.; Ernest C. Baker, with Frank Mayr & Sons, South Bend, Ind.; J. H. Sunne, Negaunee, Mich.; L. J. Will, of Hahn & Will, Iron Mountain, Mich.; E. T. Marsh, Emmetsburg, Ia.; Louis W. Otto, Crawfordsville, Ind.; Mr. Saxe, Gross & Saxe, Milwaukee, Wis.

After a lapse of two weeks from the time they were appointed the appraisers of the estate of Jos. Brown & Co. commenced work last Wednesday. When a CIRCULAR-WEEKLY reporter asked the receiver why the appraisers didn't get to work sooner, he was told that two of the appraisers were

CONVINCING EVIDENCE

That we can furnish you a Catalog of your own arranged to meet your local conditions

That Will Increase Your Business from 25 to 100%

Read These Letters

WORCESTER, Mass., Feb. 18th, 1908

(The Arnstine Bros. Company, Cleveland, Ohio.)

GENTLEMEN:—In answer to your inquiry will say, last fall was the first time that I used a Catalogue. You certainly made a good one for me and the business they caused was extremely satisfactory. They made hundreds of new customers for me, who have heretofore been buying from my competitors.

Our city was hard hit by the panic, most of our factories and mills being closed during the holiday season, but in the face of these deplorable conditions, my holiday business turned out exceptionally good and was principally due to the excellent Catalogue and other advertising you furnished.

You may enter my order for your new Catalogue for the next holiday season and send all the goods illustrated. The fact that I now place my order for next fall is in itself a testimonial of your production. You have my permission to use this letter in any way you wish. Yours very truly,

ANDREW P. LUNDBORG.

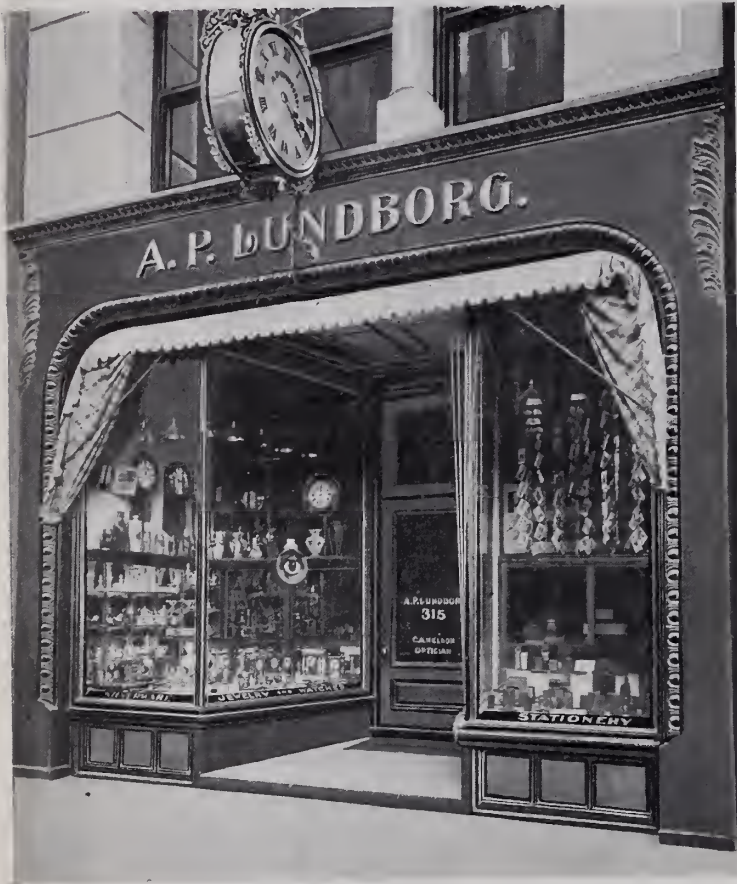

STORE OF ANDREW P. LUNDBORG, WORCESTER, MASS.

TRENTON, Missouri, Feb. 3rd, 1908.

(The Arnstine Bros. Company, Cleveland, Ohio.)

GENTLEMEN:—Answering your letter of recent date relative to the results obtained from the use of your Catalogues last year, will say that it has become such an important item in our business that we hardly see how we could do without the Catalogues.

It not only advertises our business in the country and brings customers from miles around, but we have counted as many as ten States where our Catalogue was mailed to former residents of Trenton from whom we received substantial mail orders.

This latter could not have been accomplished had it not been for your Catalogue. I am, very respectfully yours,

C. E. RANGE.



STORE OF C. E. RANGE, TRENTON, MO.

Write us at once for samples and particulars FREE

Our representatives visit nearly every State in the Union. If you are interested, and will notify us, our representative will take pleasure in calling on you and explaining our method.

THE ARNSTINE BROS. COMPANY

Originators of Our Exclusive Catalog Method for the Retail Jeweler

CLEVELAND, OHIO

IN WRITING US PLEASE MENTION THIS ISSUE "JEWELERS' CIRCULAR-WEEKLY"

busy elsewhere and couldn't attend to the Brown matter when they were appointed. The appraisers will take weeks before they can straighten matters out. From the receiver's inventory which has been filed it is evident that the American Trust & Savings Bank employ people who are not familiar with the jewelry business to take their inventories. Mr. Brown spent a few hours at his old place of business trying to find out what was left in stock so that he could know what it was worth in order to make an offer for it with a view to settling with his creditors. Hugo Pam, Brown's attorney, is fishing for an offer of settlement at 25 cents on the dollar, but so far every one is fighting shy.

Los Angeles.

Fred Guerrine, representing Wallace Bros., has gone to San Diego on a business trip.

J. Rubin, 528 S. Spring St., is now having a 25 per cent. discount sale of his entire stock.

Mrs. J. C. Fleming, who has been confined to her bed by illness, is gradually improving.

F. A. Marcher, of the Pacific Gem Co., has returned from a visit to some of the turquoise mines in Nevada.

Leonard S. Lee, of Gilmore & Lee, is making a business trip to San Diego and other sections of southern California.

William H. Dutton, for a number of years watchmaker with the Geneva Watch & Optical Co., has now taken a position with William M. Kinney, 607 S. Spring St.

J. Macowsky, proprietor of the Angelus Jewelry Co., 217 S. Spring St., has returned from a trip to San Francisco, where he expects to open his store in the Whelan building in September.

J. G. Donovan, of J. G. Donovan & Co., who has been suffering from an affection of the nasal passages, and was operated upon by a surgeon, is gradually recovering his health. In spite of his suffering, he has been at his store every day.

J. Jepson, who for a number of years has been a stockholder in the H. J. Whitley Co., and is vice-president of that company, has quit the saddlery business in which he has heretofore been engaged, and is now taking an active part in the jewelry business.

Montgomery Bros., to whom was awarded the contract for furnishing the official stationery for the reception of the Atlantic fleet, including the invitations and the menus, are having a rush of work in their stationery department on orders for special stationery for clubs and private entertainments to be given during the presence of the fleet.

E. H. Kaniss, Henryetta, Okla., who is at present the only jeweler in that town, has asked THE CIRCULAR-WEEKLY to announce that he is in no way connected with the firm of Schmidt & Co. Mr. Schmidt, having made an assignment last year, is no longer in business. Mr. Kaniss claims that many wholesale firms are sending catalogues to his town addressed to men who are not in business and who have left the town, and that these catalogues are getting into the hands of people who have no connection with the jewelry trade.

Indianapolis.

Charles Mayer has bought a six cylinder automobile.

A contract for silverware for the City Hospital has been awarded to the Andrew C. Franke Co.

Among those who called on the trade last week was C. H. MacArty, of Kastenhuber & Lehrfeld, New York.

J. Harry Reed, who has been ill for some weeks, continues to improve and will soon resume his business duties again.

Frank L. Bryant, who has been seriously ill since he returned from California, was able to take one or two automobile rides last week.

Mrs. J. P. Mullally gave a large card party at the German House last Saturday afternoon. The proceeds were for the benefit of the unemployed of the city.

I. Groh, of I. Groh's Jewelry Co., spent last week in the city calling on the trade, and found that local conditions are somewhat better than they were a few weeks ago.

As a novelty in the advertising line and to keep his repairers busy, Horace A. Comstock had a clock cleaning day last week, when he offered to clean any ordinary clock for \$1.25.

After long service with Dauchert & Axline, Noblesville, J. E. Wood has taken a position with Edward Williams & Co., at North Vernon, and has gone to that city to reside.

The Arts and Crafts Shop, 234 Massachusetts Ave., will have its semi-annual exhibit May 27-28, when the work of the students for the last six months will be exhibited. Pieces in hand-wrought jewelry will be shown together with other samples of work done. A large number of invitations are being sent out to prominent residents of the city.

C. B. Dyer, a Massachusetts Ave. jeweler, who is also conducting several classes in arts and crafts, is arranging to take a party of his students and their friends to Europe on June 20. They will be gone 70 days, and the trip will cost \$560. The party will visit Belgium, Holland, Germany, Austria, Italy, Switzerland, France, England and Scotland, and will be in London for the London Art Congress, Aug. 6-10. About 15 persons will make the trip.

It is probable that as a result of the talk of Ralph B. Clark before the Indianapolis Retail Jewelers' Association, that organization will take some steps to protect its members from traveling dealers who flock to Indianapolis each holiday season. Mr. Clark said the jewelers should not permit such bric-a-brac dealers to take the cream of the holiday trade and then move on to some other city. There is, of course, a daily license which such dealers must pay, but jewelers feel that it is not high enough.

R. M. Culver, Wellsboro, Pa., last week moved his stock into newly furnished quarters in the Navle building. Mr. Culver, who has been in ill health for the past two years, a few days ago went to the Williamsport Hospital, where he will undergo an operation. He has the sincere wishes of his many friends in the trade for a speedy recovery.

Cleveland.

A. E. Kintner, Painesville, O., is holding an auction.

A. E. Ellbogen, of the Bowler & Burdick Co., is just in from a satisfactory trip.

Ed. Doe, a retailer from Newark, O., spent a few hours in Cleveland Friday.

H. S. Hulburt, of the Scribner & Loehr Co., has just started out on a regular trip.

E. R. Kant, of the Non-Retailing Co., Lancaster, Pa., was a visitor in Cleveland last week.

Mr. and Mrs. C. E. Wittaker, Clyde, spent several days in this city during the past week.

W. F. Miller, of the Bowler & Burdick Co., is taking a week's vacation with his sister at Crestline, O.

Biskind Bros., F. H. Kramer and Chas. Ettinger discontinued their auctions after a week or 10 days' trial.

L. M. Levy, secretary and general agent of the Philadelphia Watch Case Co., was a very welcome visitor during the past week.

A. G. Lee, one of the E. Howard Watch Co.'s 20 missionaries, made a large number of sales here during the past week to retailers.

J. R. Stebbins, president of the Ohio Retail Jewelers' Association, stopped over in Cleveland Friday for a short time, on his way to Cincinnati.

The jewelry store of Henry Hayver, Payne Ave., N. E., was recently robbed of several hundred dollars' worth of goods by five young men. Passers-by saw the youthful burglars, but they were taken for clerks and not molested.

Mr. Duffner, of the Duffner & Kimberly Co., New York, was here last week, arranging for the installation of a stock of fine lamps, electroliers, art fixtures, etc., that his concern will maintain in connection with the interior decorating business of Bowman & Dodd Co., 2601 Prospect Ave.

B. V. Arnstine, president of the Arnstine Bros. Co., left Thursday for an extended business trip. H. W. Arnstine, of this house, is getting ready for the road and expects to leave in a few days. The wife of A. L. Davis, secretary of the company, is expected home to-morrow from a two months' visit to friends in Texas.

The following retail dealers visited Cleveland during the past week: H. H. Brainard, Medina, O.; Robert Miller, Lorain, O.; Mrs. A. R. Kimpton, Oberlin, O.; Chas. M. Wilson, Salem, O.; F. H. DeWitt, Port Clinton, O.; Geo. Hagle, Medina, O.; Mr. Dickinson, Jr., of G. W. Dickinson & Son, Ashtabula, O.; J. H. Erlich, Detroit, Mich.; E. D. Kindig, Elyria, O.; John Wolf, Spencer, O.; W. P. Carruthers, Oberlin, O.

Mr. and Mrs. A. T. Hubbard and Miss Marguerite Hubbard will leave next Thursday for San Francisco to attend the wedding of Sterling Beckwith Hubbard and Miss Evelyn Woodruff Levkowitz. The wedding will take place Wednesday, April 29, in Grace Episcopal Church, San Francisco. After the ceremony the bridal supper will be given at the Fairmont Hotel. Mr. Hubbard and his bride will return to Cleveland about the middle of May, and will be at home, 2174 E. 46th St., until Sept. 1.

Hull Detachable and Interchangeable Handle Umbrellas

were first put on the market in 1900, after a year spent in perfecting them. They are made to-day exactly as we made them then, so any one having a handle bought of us eight years ago can attach it to any detachable umbrella we make to-day. Our imitators have put many makeshift detachable handles on the market since then. Some makers brought out four kinds in as many years, all of which were unsatisfactory.

We believe a merchant must become disgusted when asked to buy a different detachable feature each year, none of which will interchange. The day is past for a jeweler to buy umbrellas without interchangeable handles. Then, why not do what thousands of the most successful merchants have done for years, viz.: buy umbrellas with a reputation and with a detachable feature which is "the same yesterday, to-day and forever"? Buy umbrellas with the name HULL on the button. "It means as much as Sterling."

Our line of Handles for the coming Holiday Season is now ready for your inspection.

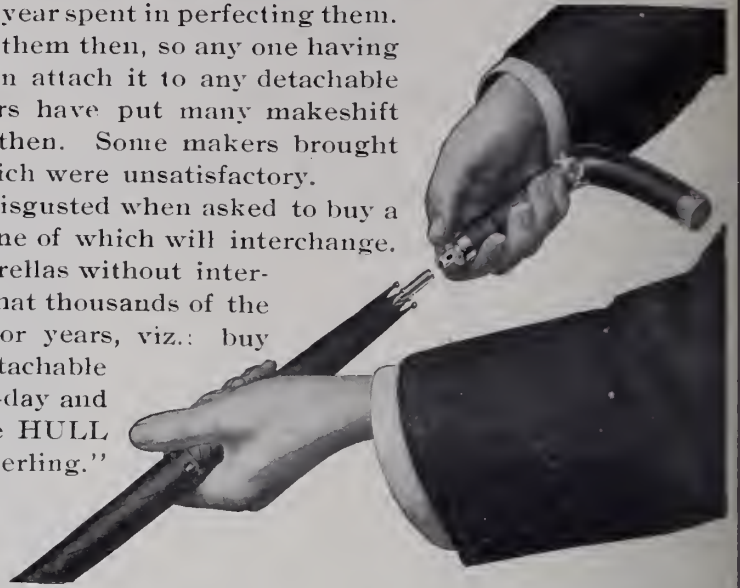

Hull Brothers Umbrella Company

344 - 346 Summit Street,

Toledo, Ohio

ENGELSMAN'S PATENTED COMBINATION "GEM" DISPLAY RINGS and ADJUSTABLE STONE HOLDERS MEET A LONG-FELT WANT

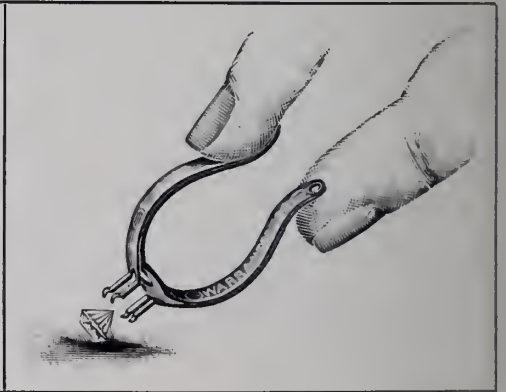
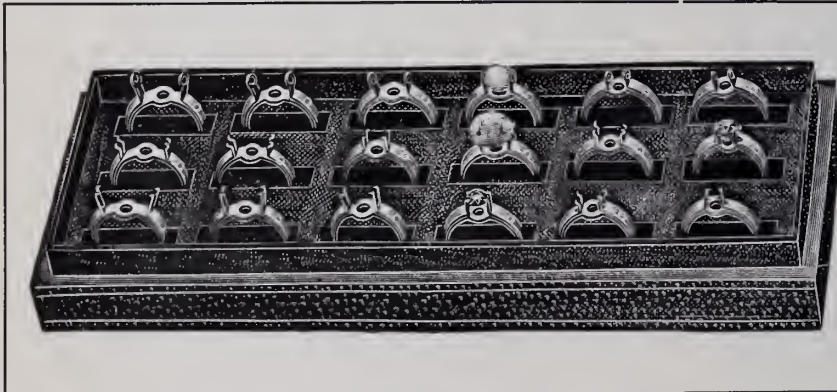

THEY ARE MONEY-MAKERS AND MONEY-SAVERS

UNMOUNTED STONES of any size and shape can be displayed advantageously, as is herein illustrated. Your investment in stock can thereby be *decreased*, as you need not mount them up in expensive settings. Your sales will also *increase* by being able to exhibit unmounted stones. The prices are *low* enough to induce you to buy them and *save* you from incurring frequent losses caused by the awkward handling of the tweezer when your customer desires to examine unmounted stones. Try them. For sale by all jobbers.

Due to greatly improved automatic machinery and reduced cost of production, we are now quoting these as follows:

Sets of 18 (full set), in box,	\$6.00
" " 12	" " 4.00
" " 9	" " 3.00

HAMMEL, RIGLANDER & CO.

47 Maiden Lane, New York

Selling Agents for United States and Canada

Cincinnati.

Louis Rauch leaves, this week, on his regular business trip to his western trade. George M. Braham, of A. & J. Plaut, left this week on a purchasing trip to the eastern markets.

Burt Ganz, of the Gustave Fox Co., left, this week, for the east on a seven weeks' business trip.

J. V. Kennedy, of the Dennison Mfg. Co., is spending a few days at the company's factory in Boston, Mass.

J. C. Horton, of Jackson Center, O., and his bride, called on friends here while on their honeymoon recently.

A. M. Leibman, of E. P. Reichelm & Co., stopped over here last week on his return from French Lick Springs.

Fred Gruen, of D. Gruen, Sons & Co., and his wife have returned from California, where they spent five weeks.

William Donnelly, of the J. S. MacDonalld Co., Baltimore, Md., spent a few days here visiting friends last week.

The father of E. G. Lohmeyer, Newport, Ky., and an old resident of that place, died last week at the age of 83 years.

D. J. Gutmann, of L. Gutmann & Sons, left Japan, April 14, for America, after a very enjoyable sojourn in that country.

H. I. Jacobson, of A. & J. Plaut, and his family sailed, recently, for Copenhagen, Denmark, where they will visit Mr. Jacobson's parents.

Mr. and Mrs. John M. Bigwood, Terre Haute, Ind., called on friends here on their return recently from Florida, where they spent the winter.

A. M. Dueber, president of the Dueber Watch Case Mfg. Co., accompanied by Mr. Loeb, of this concern, called on the local trade during the past week.

Julius Huttmacher, a jeweler, who was arrested and bound over to Grand Jury on the charge of assaulting Waldmar Dettleson, was tried, April 7, and found guilty.

Mack Hurlbut, president of the American National Retail Jewelers' Association, and I. M. Radabaugh, the secretary, were here last week and conferred with the local association, April 10, when matters regarding the coming convention were talked over and more satisfactory plans made for the convenience of national and local bodies.

Wallenstein, Mayer & Co. are installing machinery for a factory where they will manufacture their own rings and do repair work. M. Shapira, watchmaker for this firm, will have charge of the factory. "Joe" Loos, who has been with this company for five years, has been added to their road force, and is now making his first trip in Indiana and Ohio.

Out-of-town jewelers who were here during the past week purchasing goods included: Owen Sherwood, Falmouth, Ky.; W. J. Morris, Jeffersonville, Ind.; J. C. Meyer, Harrison, O.; Charles Diefenbach, Hamilton, O.; Mr. and Mrs. J. H. Drake, Lebanon, O.; Jesse Yohe, Decatur, Ill.; Mr. Adler, of D. Adler & Son, Lexington, Ky., and A. Bland, Greenfield, O.

The Clemens-Oskamp Co. is adding what was formerly the offices, an area of 900 square feet, to its retail department, which will increase the capacity one-third. The new part will be fitted up with new fixtures,

cases and mosaic floor designed by C. Oskamp Daller, the manager. A large balcony will also be built as a second floor, wherein the offices of the retail and wholesale departments will be located.

Detroit.

W. W. Bridges, Marine City, was in this city, recently.

E. S. Barnes, Rochester, visited this city last week, to make purchases.

W. A. Sherwood, Dundee, was here, calling on the wholesalers last week.

Mr. and Mrs. J. W. Barry, Vanderbilt, have been here for a visit of several days.

H. H. Holly and L. A. Sands, both of Ortonville, were recently visitors to this city.

A big wooden watch sign was stolen from the front of the store of H. S. Fecheimer, last week.

Fred J. Binder, of the Detroit Jewelry Mfg. Co., was ill and away from business most of last week.

George Johnston, of the Johnston Optical Co., left last Friday for New York and Atlantic City for a stay of two weeks.

Henry Dorweld, of the Luths, Dorweld & Haller Co., returned, Saturday, from a two weeks' trip through the northern part of the State.

W. F. King, Jr., is the happy possessor of an annual pass to Bennett Park, being an old friend of President Navin of the Detroit baseball club.

Elias D. Trebilcock, who recently sold his store at 324 Woodward Ave., has purchased a farm of 150 acres near Birmingham, and will raise fine stock.

M. C. Haldeman, of Edwards, Haldeman & Co., is back for Easter after a trip to California and the southwest. H. F. Brown, with the same company, has also returned from a southern trip.

Two jewelers have won mayoralty honors in towns near Detroit at the Spring elections. Both are Democrats. W. F. King, Sr., of Adrian, was re-elected by 284 votes, and J. S. McGlaughlin won in Wyandotte by a big majority.

Minneapolis and St. Paul.

R. G. Winter, Minneapolis, has returned from an extended eastern trip.

I. D. Allen, Cooperstown, N. Dak., and wife were recently in the Twin Cities.

Mrs. A. J. Rost, wife of the jeweler at St. Peter, Minn., visited friends in Minneapolis, last week.

The marriage of Miss Leola Lola Leber, daughter of W. C. Leber, and Dr. E. Wanous, was celebrated at the home of the bride's parents in Minneapolis, April 8.

The will of the late A. H. Schultz, Minneapolis, has been probated. The business was left entirely to Mr. Schultz's widow, who is continuing it in her own name.

The Blumencranz Jewelry Co., Minneapolis, is now well settled in the new quarters at 235 Nicollet Ave., the front of the store having been fitted up in white marble and plate glass, making an attractive appearance.

C. W. Townsend, said to be a traveling

representative, was recently taken into custody in St. Paul and held for the grand jury on a charge of forgery. Townsend attributed his downfall to the excessive use of narcotics.

Recent out-of-town jewelers in the Twin Cities include: A. E. Palmer, Grand Forks, N. Dak.; Paul V. McCoy, Minot, N. Dak.; T. J. Thompson, Barron, Wis.; Oscar Holmes, Cambridge, Minn.; A. R. Hawkinson, Towner, N. Dak.; Mr. Doolittle, Sauk Center, Minn.; Dr. Robertson, Cottonwood, Minn.

Axel Madsen, Minneapolis, a member of the wholesale firm of Rettig, Hess & Madsen, Chicago, leaves, April 16, for a three months' trip on the Continent. He will proceed to London, thence to Paris, and will visit Holland, Belgium, Germany, Copenhagen and Norway. He will sail on the White Star Line S.S. *Adriatic*.

Kansas City.

J. C. Kemp has moved his jewelry store from Mutual, Okla., to Mansfield, La.

C. B. Warner, recently of Chicago, has been added to the traveling force of the C. B. Norton Jewelry Co.

H. W. Wesley, a student at Misoman's Engraving School, has gone to Los Cruces, N. Mex., in the hope of recovering his health.

J. P. Telfer, recently in business for himself on E. 9th St., has taken a position with N. Konrad, 810 Grand Ave.

Charles Moll, now with A. Y. Boswell, Tulsa, Okla., spent a few days in this city, last week, visiting friends.

M. S. Murray, traveling representative of the C. B. Norton Jewelry Co., has moved his family to this city from La Monte, Mo.

C. P. Kionka, of Kionka & Kionka, is out for his house on an extended trip through Iowa, Minnesota and Wisconsin.

C. E. White, having finished a course at the Kansas City Horological and Optical School, has returned to his home in Rolfe, Ia.

A. E. Pettenger, manager of the Kansas City Horological and Optical School, pleasantly entertained his students, their wives and their lady friends, Thursday evening.

F. A. Ryer & Co. have moved into new and larger quarters at 109 E. 12th St., having outgrown the old quarters at 17 E. 12th St. The new store is furnished in a strictly up-to-date manner.

The business of the Gurney & Ware Jewelry Co. has been entirely closed out. Mr. Ware has an office at 518 Altman building, and is doing work for the trade. Mr. Gurney has an office with the Findlay Art Co., but has formulated no definite plans for the future.

The following out-of-town jewelers were here last week: C. A. Clement, Springfield, Mo.; J. H. Whiteside, Liberty, Mo.; A. Y. Boswell, Tulsa, Okla.; H. L. Morrison, Pittsburg, Kans.; E. E. Lawrence, Doniphan, Mo.; T. G. Allen, Miami, Okla.; C. L. Dockhorn, Oskaloosa, Kans., and Mrs. Chas. E. Dickinson, Garden City, Kans.; F. W. Holmes, Thayer, Kans.; F. N. Newton, Missouri City, Mo.; George H. Church, Oak Grove, Mo.

O. V. Peterson, Lehigh, Ia., has sold out. F. F. Nelson continuing the business.



JOHN F. TURNER

Expert Jewelry Auctioneer

2 Maiden Lane, New York, N. Y.

The following leading and representative firms, for whom I have conducted successful sales, will inform you what I have done for them. I can do the same for you.

- | | | |
|---------------------------------------|--------------------------------------|---|
| James D. Murphy, New York, N. Y. | Frankfort Jewelry Co., Norfolk, Va. | Breen & Morris, Attys., Ft. Wayne, Ind. |
| J. E. Steere, Charlotte, N. C. | J. P. Morgan Co., St. Louis, Mo. | Dorken Bros. & Co., Montreal, Canada. |
| George Wolf & Co., Louisville, Ky. | C. G. Schulze, Halifax, N. S. | Otto H. Fasoldt, Albany, N. Y. |
| S. N. Jenkins & Co., Richmond, Ind. | Frank Curtis Company, Decatur, Ill. | C. A. Sterner, Allentown, Pa. |
| G. Heitkemper, Portland, Oregon. | C. H. Knights & Co., Chicago, Ill. | Wm. Vogel, New Britain, Conn. |
| Morris G. Cohen, Pittsburg, Pa. | Ernst Schall Co., Hartford, Conn. | McConahay Co., Salt Lake City, Utah. |
| Jaccard Jewelry Co., Kansas City, Mo. | J. K. Basaye, Seattle, Wash. | S. Kitani, Cleveland, Ohio. |
| C. W. Ernsting, San Diego, Cal. | Thos. J. Routledge, Elmira, N. Y. | G. C. Bowen, Niagara Falls, N. Y. |
| E. A. Souder, Albany, N. Y. | T. Porte & Co., Grand Forks, N. Dak. | Anderson & Co., Ishpeming, Mich. |
| M. Henriksen, Duluth, Minn. | B. A. Southerland, Charlotte, N. C. | M. E. Brown, Battle Creek, Mich. |
| Wm. V. Blair, Meriden, Conn. | Lord Bros. & Co., Milwaukee, Wis. | |
| C. O. Haines, Columbus, Ohio. | | |

New Universal Three-Jaw Chuck

Self-Centering Drill Step and Bezel Chuck

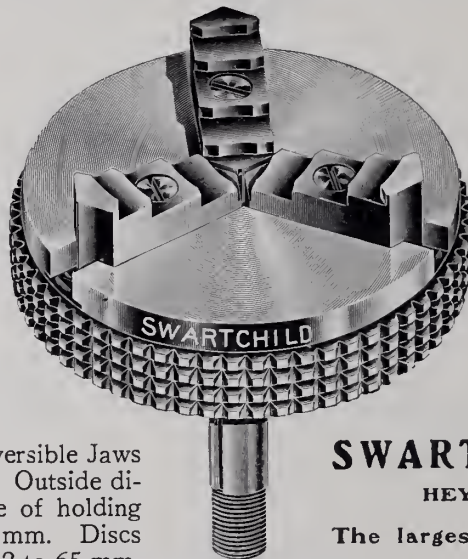
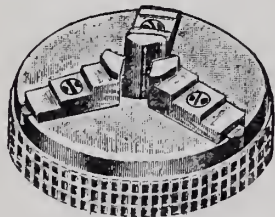

No. D 58 - Mounted to fit Webster, Whitcomb and Moseley No. 2.
Price, each - - \$9.00

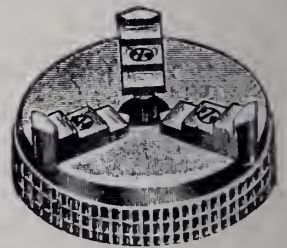

If you have not a copy of our double-sized, 440-page Catalogue, write at once. Sent gratis upon application.

This New Universal Chuck with Reversible Jaws is the most practical on the market. Outside diameter 62 mm. (2½ inches). Capable of holding drills and wire from smallest up to 10 mm. Discs from 6 to 58 mm., and Bezels from 12 to 65 mm.

SWARTCHILD & COMPANY
HEYWORTH BUILDING, CHICAGO

The largest exclusive jewelers' supply house in the world

The New Continental Watch Co.'s Movements.



0, 12 and 16 Size. 7 to 21 Jewels.
All Bridge Model and Pendant Set.

Fitting all American cases without any change, interchangeable pendant set, have steel scape wheels, exposed pallets, double roller, Arabic or Roman dials, with and without marginal figures. CONTINENTAL WATCH CO. on bridges, C. W. CO. on dials except otherwise ordered. Special name or nameless movements require four months' time for delivery. Packed in glass show box inside paper box. No expense has been spared to make these movements the best on the market for the money. Every movement absolutely guaranteed. A full line of finished material constantly on hand.

For Sale by all Jobbers.

JULES RACINE & CO., Exclusive Importers,

103 State St., Chicago.

37 MAIDEN LANE, NEW YORK.

LOUIS FELDENHEIMER

Importer and Cutter of

PRECIOUS STONES AND PEARLS

41 MAIDEN LANE

NEW YORK

THE GREAT AMERICAN JEWELRY CATALOG

Is a publication of real practical value; it truthfully illustrates those lines of merchandise; best adapted to the needs of the *Jewelry Trade*; its reliability is unquestionable.

SAFETY

With implicit confidence you can use it when ordering goods; it insures you against deception; remember, for every dollar's worth of merchandise you buy you are obtaining positive, intrinsic value.

Write for this catalog; it means much to you.

THE OSKAMP-NOLTING CO.

Mammoth Wholesale Jewelers
411-413-415-417 Elm St., CINCINNATI, OHIO

WORKSHOP NOTES

For Jewelers and Watchmakers. Cloth. Postpaid \$2.50. Published by The Jewelers' Circular Publishing Co., 11 John St., New York.

San Francisco.

TRADE CONDITIONS.

The general situation in the jewelry trade here is unchanged, although some of the retailers report a perceptible increase. The out-of-town jewelers have purchased their Summer stocks and traveling representatives, who are just in, report sales below normal for this season.

A. I. Hall & Son have just completed taking inventory.

H. R. Bardwell has recently become associated with the sales department of the J. B. Whitney Co.

The J. S. Lehrberger Co.'s representative, Mr. Cohn, left here last week on his regular southern trip.

Mesik & Co., formerly of 618 Van Ness Ave., have moved to new quarters in the Mutual Savings Bank building, on Market St.

The home of Thomas Lundy, a prominent jeweler, caught fire, April 6, but was extinguished before any serious damage was done.

Walter T. Harris, Los Angeles, who has been in this city for about a week, visiting the trade, returned to the southern city, last week.

Walter Hovey, with the J. B. Whitney Co., San Francisco, has just returned from a business trip to Santa Cruz, Cal., and other coast points.

Morris Van Vliet, of the Baldwin Jewelry Co., has returned from Europe, where he has been since last September on a pleasure trip.

Ed. Bastheim, with the Alphonse Judis Co., is now on his regular trip in the coast territory, north of this city, while Chas. F. Rednall, with the same firm, has just returned from the south.

Fritz Barkan, who has been with the California Jewelry Co., left recently for Europe, where he expects to make a special study of diamonds and precious stones under experts in that line.

A. O. Gott, Alameda, Cal., recently lost a valuable blooded horse. One morning a box containing some feed mixed with poison was found in the animal's manger. The animal died after much suffering.

Among the out-of-town jewelers who were in this city, last week, were: Matthew Giant, Vallejo, Cal.; F. W. Graf, St. Helena, Cal.; L. L. Berens, Bellingham, Wash., and M. Dobrowsky, Redding, Cal.

Col. Andrews, proprietor of the Diamond Palace, at 909-911 Van Ness Ave., celebrated his 82d birthday, April 7. Mr. Andrews is still hale and hearty and greatly enjoys the congratulations of his many friends on the passing of another mile post of his career.

Among a party of 56 prominent Japanese business men and educators who arrived in this city, April 3, were Y. Hori, a jeweler of Osaka, Japan, and his wife. They were the guests of the California State Board of Trade, the Oakland Chamber of Commerce and the local Japanese colony before departing for the eastern States.

Joseph M. Wolf, 78 years of age, and formerly a prominent man in the business circles of San Francisco, where he was connected with the wholesale jewelry firm of Lorseh-Wolf & Co., committed suicide in his room, on Pine St., here, April 4. De-

spondency and fear of blindness are attributed as the cause of the action.

Hammersmith & Co. expect to be located in their new quarters in the Hammersmith building, on the corner of Grant Ave. and Sutter St., after May 15. This will be the only jewelry firm in the west occupying an entire structure of this kind. At present the firm is conducting a sale at the Van Ness store, preparatory to removing.

A package containing 100 valuable rings, which was stolen from Wells, Fargo & Co. some weeks ago, has been found at the store of a Mr. Isaacs, on Van Ness Ave., the package having been sold to him for \$100. After the rings were identified and returned to the losers, an employe of Mr. Isaacs identified the man from whom he bought the package.

Alexander T. Lipman, a traveling representative for the Morgan & Allen Co., 717 Market St., and for years one of the best-known traveling men on the coast, is now ill in an Oakland hospital. He was brought to Oakland by his brother, having broken down from overwork. His friends hope and believe that he will soon recover, though his condition is recognized as serious.

Pacific Coast Notes.

L. E. Pels and A. Glass, San Francisco, are guests at the Hollenbeck Hotel, Los Angeles, Cal.

Jacob Glick, Stockton, Cal., has recovered from a five months' illness, and is now attending to his business again.

F. J. Rigg has finished the store rooms in his new brick block on W. Main St., Alhambra, Cal., and is occupying the east room with his jewelry store.

A burglar broke into the Morley Investment Co.'s store, 446 S. Main St., Los Angeles, Cal., by smashing a skylight last week. He took 16 watch cases, one watch and 15 revolvers.

Manson & Bay, San Bernardino and Redlands, Cal., have dissolved partnership. Mr. Manson has bought and taken charge of the San Bernardino store. The Redlands store has been bought by W. C. Guerth.

E. Troutman has contracted to lease one of the store rooms in the new business block which is being built at the northwest corner of Madison Ave. and 2d St., Yuma, Ariz. As soon as the building is completed he will move his store there from its present location.

The jeweled key to the freedom of the city to be extended Admiral Evans has been completed by Joseph Jessop & Sons, San Diego, Cal. It is worth about \$250. This concern has installed an immense clock on the sidewalk in front of the store. It is encased in plate glass and is visible at a considerable distance.

Pacific Northwest

Mrs. Lizzie Luckey, wife of Joseph S. Luckey, Eugene, Ore., died at her home, at that place, last week.

A petition is in circulation at Snohomish, Wash., for subscriptions to the fund which the city expects to raise for a cut glass factory. Already over \$8,000 has been

subscribed, but about \$20,000 will be necessary.

John Daynes & Sons, Salt Lake City, Utah, has purchased the Daft building, a four-story brick stone-trimmed structure at 126 and 128 Main St., for \$75,000. The property was bought for an investment, and the company intends, as soon as the present lease on the ground floor has expired, to move from its present site at 26 Main St., to the newly acquired property.

Omaha.

T. L. Combs & Co. opened for business with a fire sale last week.

Mrs. A. Mandelberg has just returned from a trip to Kansas City, Mo.

Thos. Friet, Clarkson, Nebr., was in this city last week, replenishing his stock.

Miss Margaret Kerr, buyer for A. Mandelberg, is again at work, having been confined to her home by illness.

Frank Allen, of the Baum, Allen Co., Denver, Colo., came to this city last week to attend the funeral of a deceased friend.

Bret McCullough, formerly with the Shook Mfg. Co., left last week for Marshfield, Ore., where he will make his future home.

Fred Brodegaard & Co. received the settlement from the insurance company last week, and opened with a fire sale, Monday, April 6.

Col. H. J. Penfold, president of the H. J. Penfold Co., of this city, will soon leave with Gov. Sheldon and staff for San Francisco, Cal., where they will present the silver service purchased by the State as a gift to the United States battleship *Nebraska*.

Milwaukee.

The Milwaukee Jewelers' Club has indorsed the proposed law requiring that gold-filled watch cases be marked with figures showing the exact thickness of the plating instead of with the number of years for which they are guaranteed.

Many jewelers believe that on his inauguration, April 24, David S. Rose will take steps to have an ordinance passed by the common council not only to legalize street clocks, but to reimburse those jewelers who suffered by Mayor Becker's orders.

In broad daylight, recently, the store of William Platzer, 975 Kinnickinnick Ave., was robbed of a tray of diamonds, the thieves leaving no trace of their going and coming. Forty rings set with small stones were in the tray. Mr. Platzer had left the store for a moment. The loss is about \$250.

Members of the common council committee on judiciary have sent to the city attorney of Milwaukee a claim presented by W. & E. Schmidt, the 3d St. jewelers, for \$530 for damages. The petition for the recovery of the damages is an echo of the removing of street clock signs at the order of Mayor S. M. Becker, several weeks ago. The members of the judiciary committee expressed the hope that there is some way in which the city can make restitution to Messrs. Schmidt. If this claim is allowed many others will be filed.



H. J. HOOPER

NEW YORK'S LEADING JEWELRY AUCTIONEER—RECOGNIZED BY THE WHOLESALE HOUSES, THE PRESS AND HIS PATRONS

Write him for Testimonials that cannot be equaled by any Auctioneer in New York

37 MAIDEN LANE, NEW YORK CITY

The names that I publish below are merchants I have sold for direct; there are no wholesalers among them. Anyone wanting the wholesalers I have sold for indirectly, I will furnish by mail.

L. Robins, Oswego, N. Y.
Blumberg Brothers, Syracuse, N. Y.
Sun Fat Company, San Francisco, Cal.
Peter Engel, Marysville, Cal.
S. Hollander, Salinas, Cal.
A. P. Hall, Visalia, Cal.
M. Edwards, Syracuse, N. Y.
C. Wilcoxon, Carnegie, Pa.
Keystone Jewelry Co., Pittsburg, Pa.
E. A. Walker, Pasadena, Cal.
S. E. Rich, San Jose, Cal.
Andrews & Wood, Modesto, Cal.
A. Thurman, Healdsburg, Cal.
J. Frost & Co., Chicago, Ill.
A. Clark, Spencer, Ind.
C. Hill, Southbridge, Mass.
U. S. Kenshaw, Lansford, Pa.
L. M. Lasell, Martinez, Cal.
E. F. Brown, Pasadena, Cal.
J. Hyman, Sacramento, Cal.
Kohn Brothers, Missoula, Montana.
F. R. Stearns, 2 sales, Petaluma, Cal.

Ike Fields, Grass Valley, Cal.
George Johnson, San Bernardino, Cal.
R. F. Stearns, Stockton, Cal.
Thomas Howard, Marshfield, Oregon.
Franz Mahncke, Tacoma, Wash.
J. H. Shade, Brooklyn, N. Y.
John E. Knapp & Co., Salt Lake City, Utah.
James J. Tracey, Seattle, Wash.
Charles Hoff, Denver, Colo.
E. A. Walker, Pasadena, Cal.
R. Cohen, Pittsburg, Pa.
F. R. Williams, Buffalo, N. Y.
R. W. Wilson, Portland, Oregon.
Fred Woodman, Louisville, Ky.
M. Rundback & Co., Chicago, Ill.
Glendemann & Schweitzer, San Francisco, Cal.
Luke MacDonald, Visalia, Cal.
Bemas Brothers, Vallejo, Cal.
A. Tucker, Newport News, Va.
J. Luxenberg, Patton, Pa.
A. Lison, Kingston, Pa.
M. C. Khuner, Auburn, N. Y.
Everett Jewelry Co., 3 sales, Everett, Wash.
W. D. Meail, Marysville, Cal.
J. Joseph, Los Angeles, Cal.
A. Leibson, Duryea, Pa.
Davidow Brothers, 3 sales, Wilkesbarre, Pa.
Maiden Lane Jewelry Co., Elizabeth, N. J.
Dualbil Brothers, Schenectady, N. Y.
Fred. Ward, Visalia, Cal.
I. E. Gilbert & Sons, Modesto, Cal.
M. L. Stanton, Riverside, Cal.
A. E. Backs, Woodland, Cal.
M. S. Osgood, San Jose, Cal.
Chas. Wilcoxon, Napa, Cal.
George Jordan, Redblawn, Cal.

George Thomas, Auburn, Cal.
W. H. Wilson, Merced, Cal.
South Bend Jewelry Co., South Bend, Wash.
B. Banetti, Ferndale, Cal.
D. E. Gilbert, Modesto, Cal.
M. Barboska, Santa Cruz, Cal.
L. Robins, Utica, N. Y.
Yoshimi & Co., Atlantic City, N. J.
Cummings & Son, San Francisco, Cal.
J. M. Ives, Meriden, Conn.
E. H. Kutner, Albany, N. Y.
S. Susman, Stamford, Conn.
Rival Jewelry Company, Los Angeles, Cal.
A. H. Broon, Boise City, Idaho.
Levison Brothers, Oakland, Cal.
O. A. Dockban, N. Tonawanda, N. Y.
A. Benjamin, Denver, Colo.
M. BasBarker, Fresno, Cal.
J. M. Dickson, Stockton, Cal.
I. M. Jacobsen, Ferndale, Cal.
J. Rupert, Terentum, Pa.
C. O. Biederman, Oneonta, N. Y.
Freeman Jewelry Co., Niagara Falls, N. Y.
Arritt & Co., Newport News, Va.
T. J. Routledge, Elmira, N. Y.
Rosenblatt & Co., Greenville, Tenn.
M. Marter, Cottage City, Mass.
J. F. Rockwell, Port Jervis, N. Y.
J. M. Frear, Binghamton, N. Y.
Palace Jewelry Co., Auburn, N. Y.
J. Luxenberg, Hurtzdale, Pa.
H. Hedges, Fairmount, W. Va.
A. E. Morro, Los Angeles, Cal.
A. B. McKelvey, Pasadena, Cal.
Bogart & Page, Binghamton, N. Y.
A. F. Redfoot, Mt. Jewett, Pa.

THE DORAN COLLAR AND VEIL PIN



PAT. 1904

The only pin made with perfect joint and catch without riveting or soldering

The pin rests in a cup and the front is closed on. With such construction the pin cannot break or pull out of the joint.

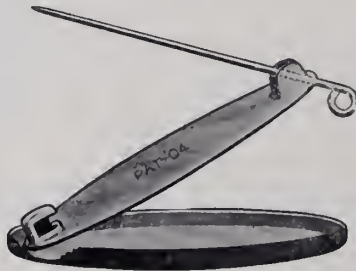

Made in heavy Rolled Gold Plate in a complete line of sizes, patterns and finishes. Prices are lower than a soldered article of the same fineness.

CATALOGUE UPON APPLICATION

JAMES C. DORAN & SONS

DORAN BUILDING

PROVIDENCE, R. I.



Light Lofts To Let

IN THE NEW

GIBSON BUILDING

N. W. Cor. John and Gold Streets

NEW YORK

About 4,200 square feet for Light Manufacturing or Show Rooms.

ELECTRIC ELEVATOR AND STEAM HEAT

All lofts wired for power. Apply to your Broker or on Premises.

Harrisburg, Pa.

The Jeddo Supply Co. was chartered at the State Department last week.

J. H. Miller, Mercersburg, has employed Charles A. Keepers as an optical specialist. Mr. Garner has removed his jewelry and furnishing goods store from 6th and Muench Sts. to 1209 N. 3d St.

E. S. Loy, New Bloomfield, has broken ground for a new residence, 30 by 30 feet, to be built of granolithic blocks.

The Philadelphia & Reading Railway watch inspector will be here April 21, and at the Rutherford shops and yards April 22.

The Lebanon Retail Merchants' Protective Association will have its annual outing at Willow Grove Park, Philadelphia, this year.

Clise & Klein, opticians, of Allegheny, Pa., have rented a storeroom on N. Hanover St., Carlisle, and will begin business there shortly.

Rev. L. C. Smiley, pastor of the First U. B. Church, Greencastle, Pa., has resigned to engage in the jewelry business in Lemoine, directly opposite this city.

Myers Bros. have succeeded Myers Bros. & Co., York, and the partners who now conduct the establishment at 58 W. Market St., are William P. Myers and J. Luther Myers.

Joseph S. Rinkenback, optician in the jewelry establishment of his father, E. L. Rinkenback, has returned from New York, where he took a special course in optics in the New York Institute of Optometry.

Local jewelers have quite a quantity of repair work on hand just now. In one establishment the other day there were 140 or more watches and as many clocks requiring attention. One dealer stated that he always spent about an hour each morning in winding these timepieces.

Charles A. Snotterly, arrested in Hagerstown, Md., recently, on the charge of being implicated in the robbery of May's jewelry store at York, Pa., refused to go to York without requisition papers. Snotterly, who is 32 years old, was recently pardoned from the Maryland Penitentiary, to which institution he was sentenced for robbing the store of Samuel Emmert, Hagerstown, of jewelry, watches, rings, etc.

Atlanta, Ga.

M. Greer, a local jeweler, is receiving considerable newspaper publicity upon his unique invention, an automatic dust pan, for which he has been granted a patent.

Fred R. Saul, formerly connected with Nat. Kaiser & Co., this city, has purchased the business of M. Loeffler, Chattanooga, Tenn., which will hereafter be run under the style of Fred Saul & Co.

Martin May, Charles H. May, G. M. Tipp, H. May and H. H. Schaul recently applied for a charter for the Charles M. May Co., the capital to be \$15,000, with the privilege of increasing it to \$50,000. The shares are to be sold at \$100 each. The concern proposes to do a general jewelry and brokerage business.

A very able editorial on the condition of the diamond market headed "No Danger of Diamonds Toppling" appeared in the *Atleboro Constitution* Sunday, April 5, and had a marked effect in the way of restoring the

confidence of those people who had been influenced by the many silly reports as to the prices of diamonds that had appeared in the daily papers in the past month. The editorial in the *Constitution* reviewed the situation in regard to the production of rough diamonds, and showed how false were the reports that had been published, concluding by demonstrating that the diamond market was as firm as ever, and that if there was any change in the price it would be apt to be in an upward direction. Maer & Berkele, of this city, were essentially responsible for the publication of the editorial, as it was written at their request to publish the truth.

Providence.

Among the new directors selected by the voting trustees of the Union Trust Co. are: William A. Copeland, of the Martin-Copeland Co.; Harry Cutler, of the Cutler Jewelry Co.; Samuel W. Nicholason, of the Nicholason File Co., and Henry D. Sharpe, of the Brown & Sharpe Mfg. Co.

A fire which burned a house in N. Swansea St. early last week for a while threatened the jewelry factory of D. R. Child and also his home, owing to the many burning embers which flew in that direction. However, the wind was not strong, and Mr. Child's home and factory were uninjured.

Students to the number of 869 are now registered in all classes of the Rhode Island School of Design—168 in the day classes, 494 in the evening classes, and 207 in the Saturday classes. The director reports a falling off of a number of students in the evening jewelry class, but reports that a new class in metal work and silversmithing has been started on Saturday afternoons, under the direction of A. F. Rose. There are 15 students in this course. Many fine additions have been made to the exhibition of jewelry and silverware, and many loans and contributions have been received for this section of the museum.

Association Notes.

The act of incorporating the Maryland Retail Jewelers' Association was signed last week. The incorporators under the charter are Jerome W. Schirm, Frank Persohn, Fredrick J. Euler, George J. Walters and John J. Bartholomee.

A determined effort is being made by the officers of the Pennsylvania Retail Jewelers' Association to increase the membership of that body and also to have as large a representation as possible at the coming State convention. In a letter sent out by the officers and signed by A. C. Graul, Sharpsburg, the president, and C. S. Wiley, Pittsburg, the secretary, the attention of the members is called to the good work the State and the national associations are doing, and the members are urged to swell the ranks of the Pennsylvania body by sending in applications. It is stated that the association has been invited to hold its convention in Philadelphia at the time the American Association of Opticians meets there, Aug. 10 and 13, and the members are asked to express their views as to whether the association should meet in Philadelphia in August or in Pittsburg in July.



Thomas McLane has engaged in business for himself at Shubert, Nebr.

John Batches has opened a small jewelry store at Kahlotus, Wash.

The Michigan Show Case Co. is the name of a new firm established in Detroit, Mich.

W. B. Bellamy, of Kansas City, Mo., has started in business at Sweet Springs, Mo.

The Omaha Silver Co. has been incorporated in Omaha, Nebr., with a capital of \$25,000.

The Weber Detachable Main Spring Co. contemplates engaging in business in Wau-seon, O.

T. J. Johnston has started in business as a manufacturing jeweler at 33 Macdowell Ave., Toronto, Can.

Earl Clay, engraver of Omaha, Nebr., has removed to Norfolk, Nebr., where he will open a jewelry store.

C. H. Dimmick and Isadore Spelman have opened a new store at 139 Washington St., Butte City, Mont.

Paul Steinke, at one time in business at Wallace, Idaho, is making preparations to open a store in Mullan, Idaho.

J. Russell will soon open a store in the Barber block, at Riverside, Cal. Mr. Russell recently purchased an orange grove at that place.

S. Simmons will open an establishment at 731 Sansom St., Philadelphia, Pa., where he will make a specialty of repairing work for the trade.

Emil Weiss will shortly resume business at Reading, Pa., where he will conduct a jewelry store under the style of the Novelty Jewelry Co., on S. 6th St.

The Coffman Optical Co. is a new concern in Oklahoma City, Okla. The firm has a capital stock of \$100,000. E. F. Davis, E. S. Ferguson and W. W. Wynne are the incorporators.

The American Clock-Bank Mfg. Co. was recently incorporated in Lynn, N. Y., with a capital of \$50,000. The officers are: President, H. B. Copland; treasurer, W. H. Parrish, Lynn; clerk, B. F. Borhek, Dorchester.

The Oro Mfg. Co. is a new concern which has been incorporated in Ashland block, Chicago, Ill., with a capital stock of \$10,000, to manufacture jewelry. The incorporators are Chas. R. Brown, Charles Martin and H. M. Buall.

The American Watch Supply Co. is the name of a new concern which has recently been incorporated in Boston, Mass., with a capital stock of \$500,000. The officers are: President, L. W. Luwellen, Newton; treasurer, H. J. Potter, Cambridge.

Denny & Ellington, Greensboro, N. C., have moved from S. Elm St. into larger quarters at 103 W. Market St. The new establishment will be known as "The Little Store Around the Corner."

The Mail-Order Problem and How to Meet It.

(Address by JOSEPH GILBERT, President National Anti-Retail Mail Order League, before the Illinois Retail Jewelers' Association.)

(See report on page 47.)

THE mail-order problem is the burning question with almost every retail merchant throughout the country, and for that reason the National Anti-Retail Mail Order League was instituted as an aid to the merchants in meeting the difficulties this problem presented. The whole question is simply one of competition, and no amount of invective and abuse hurled at one's competitor will avail anything in solving the problem. This is an age of combination; therefore the first thing to do is for merchants to organize. As individuals they are helpless to enforce fair conditions in the field of competitive industry, but collectively they can do this. The Anti-Mail Order League has rendered valuable assistance by getting the retail merchants together and voicing their interests in a manner to command fair treatment at the hands of manufacturers and jobbers who previously imagined they could do as they liked.

Although competition means industrial war, nevertheless there is a code of ethics governing in this the same as in military warfare, but it required the power of organization on the part of the retailers to insure them a "square deal." The railroads, steel trust, Standard Oil and other great combines felt as though they could do as they liked until the light of publicity was thrown upon their actions, and then public opinion was aroused to the extent of making them realize that they must act fair in their business of serving the public. Combativeness is all right in its place, but to be really effective it must be supplemented with constructiveness. In order to have a successful constructive programme it is necessary to thoroughly understand the situation to be met.

What reason has a retail merchant for being? In a correct answer to this question is the key to the whole situation. We are all interdependent and necessary to one another in so far as we render service to each other, and retailing is simply one of the necessary social services. Next let us ask, What is competition? It is an effort on the part of two or more individuals to render the same kind of service. Naturally it follows that those who render the best or most efficient service are the successful ones. It is the old process of natural law of the struggle for existence and the survival of the fittest. The mail-order concern simply essayed the task of supplying a community's wants in competition with the local merchants, and the fact of the growth and success of these concerns is because they rendered better service than many of these merchants were doing at the time they entered the field.

Business cannot be conducted on sentimental grounds. There is no reason why anyone should patronize a home merchant if they can be better served by some one at a distance. It may be hard for a small concern to compete with a large one, but this is nothing to the consumer, as he is entitled to get the most he can for his money.

Here is where organization comes in. The first thing is to enforce fair competitive conditions. In this work the National Anti-Retail Mail Order League has been a very important factor. Having a fair field, it is up to the retail merchant to so equip himself that he is able to render as good a service as anyone. If he cannot do this individually he must accomplish it collectively, or, in other words, through organization.

There are just three things to bear in mind in attaining this efficiency in business. They are: First, organization; second, right buying; third, good advertising. The two latter are means employed by an organized body, since it is almost impossible for the greatest efficiency to be attained by individual or small business house. It is thus seen that the essential thing is to get thoroughly organized, and then use this organized strength in equipping each individual in a manner that enables him to render as good a service as can be obtained. When this is done there is no doubt about the survival and success of the individual merchant, for it is ridiculous to suppose for an instant that any consumer is going to send away from home for his wants to be supplied, and take all kinds of chances in the way of receiving complete satisfaction, when he can be satisfied at home.

There will always be small as well as large communities, and the opportunity will always exist for some to cater to the needs of these various communities; it only remains, therefore, to so equip yourselves as to be in a position to render the best service obtainable and then let the community know it. As the standard of excellence is constantly becoming higher, due to competition, the individual can only hope for success by strengthening himself by organization.

News Gleanings.

The store of J. F. Sharp, Leonard, Tex., was recently damaged by fire to the extent of \$1,000.

The firm of Collis & Thomas, Pendleton, Ind., has been dissolved, Solomon F. Thomas continuing alone.

L. H. Covert, Greensboro, N. C., is now in the employ of H. B. Kurtz, Conneaut, O., as a watchmaker.

W. B. Kelly, a jeweler of San Antonio, Tex., has opened a branch store at 81 S. Main St., Memphis, Tenn.

Gordon & Reamer, Meadville, Pa., recently sustained a loss of \$500 by fire. The loss was fully covered by insurance.

J. F. Hewes, Titusville, Pa., moved recently from the Odd Fellows block at that place to the Aiken building, corner of Central Ave. and Washington St.

Burglars recently broke into the store of William Baker, Williamsburg, Ky., and escaped with several hundred dollars' worth of miscellaneous jewelry. There is no clue.

Joseph Caramothe, who was recently taken into custody in Erie, Pa., on a charge of breaking into the store of Wm. B. Krill, of that place, has been committed to the county jail to await the May term of court.

The receiver of T. G. Drake & Co., Corning, N. Y., at the recent sale of the concern, refused to let the plant and stock go for the price offered, which was only \$900, the in-

ventory amounting to \$12,500. Another sale will be held some time next month.

Gerome Desio, Washington, D. C., has returned from a five weeks' pleasure trip through Florida, on which he visited the cities of Jacksonville, St. Augustine, Daytona, Rockledge, Fort Pierce and Palm Beach.

The Union Comb Co., of Leominster, Mass., last week secured Massachusetts incorporation papers, with a stated capital of \$5,000, divided into 50 shares of \$100 each. The president and treasurer is Frank Edgerly, and the other incorporators James H. P. Dyer and Grace E. Brown.

A pearl weighing 42 grains was found in the Illinois River at Beardston, Ill., April 9. Quite a number of pearls have been found at this place during the present season, but the specimen picked up Thursday is by all odds the finest that has come from the river. The finder is said to have refused \$1,800 for the gem.

Richard Broderick, who is charged with breaking into and looting the jewelry store of G. C. Fischel, 3 George St. (Green Island), Troy, N. Y., was up for examination before Justice Farmer, Wednesday last. Mr. Fischel's store was looted by a burglar, March 23, and jewelry worth between \$500 and \$600 carried away. On April 1 detectives arrested Broderick in Albany as he came out of a local jewelry store, where it is claimed he was offering to sell articles which corresponded to those stolen from Mr. Fischel's store.

Fred Saul & Co., successors to M. Loeffler, at 9th and Market Sts., Chattanooga, Tenn., are making extensive improvements in the store and business, and within a short time will increase the stock and introduce a number of new ideas and methods in merchandizing. Mr. Saul, the head of the firm, is 35 years of age, but has been in the jewelry business all his life, and comes from Atlanta, Ga. The business which he bought out, for spot cash, is in one of the finest sections of Chattanooga, and has been prominent for 23 years.

The most important feature presented by the Buyers' Club, for which it is proposed to erect a mammoth building at St. Louis, Mo., is the plan for bringing the buyer to the seller. The fare of 10,000 buyers will be paid to St. Louis twice annually by the building company, and the exhibitors will choose the buyers who are to be brought. Special trains will be hired by the company and run from distant points where dealers from a considerable radius can be gathered. The building is designed to extend the territory St. Louis supplies, so that exhibitors will enjoy not only the immense trade of the southwest which now centers in St. Louis, but that of all the central west and northwest as well. Only a limited amount of space will be leased to each exhibitor. The eighth floor of the building will be devoted to jewelry, china and art goods, including jewelry manufactures, watches, clocks, gems, silver flat ware, optical goods, opera glasses, fans, glass, china and queens ware, cut glass, silver hollow ware, imported novelties, leather art novelties, art pottery, straw articles, wood articles, fancy work, candlebras, electroliers, bronzes, papier mache and brass ornamental pieces.

INDEX TO ADVERTISEMENTS.

me Comb & Novelty Co.....	31	Gugenheim, M.	29	Prior, Charles M.	27
Isopp Bros.	25	Hagstoz, T. B., Ltd.	110	Racine, Jules, & Co.....	76
vin Mfg. Co.....	Inside front cover	Hammel, Riglander & Co.....	8, 74	Randall, C. Ray	14
merican Gem & Pearl Co.....	56	Harris & Harrington	97	Ranlett & Lowell Co.....	96
merican-Swiss Watch Co.....	97	Hedges, A. J., & Co.....	27	Reichhelm, E. P., & Co.....	104
merican Platinum Works.....	104	Hedges, Wm. S., & Co.....	54	Reichman, A.	56
merican Watch Case Co.....	86	Heller, L., & Son.....	46	Renzlehanzen, W. F., & Co.....	110
chibald Klement Co.	28	Herpers Bros.	104	Revell, A. H., & Co.....	112
izona Turquoise Mines Co.....	44	Hill & Schmidt	26	Richards, J. M.	52
instein Bros. & Co.....	42	Himalaya Mining Co.	58	Richards, W. E., Co.....	28
instline Bros. Co.	72	Hodenpyl & Walker	50	Richardson, Enos, & Co.....	24
istln, John, & Son.....	104	Hoffman Novelty Co.	108	Robbins, Chas. M., Co.....	36
istln & Stone	21	Hooper, H. J.	78	Roger Williams Silver Co.....	27
igg & Co.	52	Hotel St. James	112	Rohrbeck, John E.	28
icker, Geo. M.	111	Howard, E., Clock Co.....	86	Roseman, A.	52
ill, Webb C., Watch Co.....	97	Howard, E., Watch Co.....	94, 95	Rothschild Bros. & Co.....	58
ischkopf, Henry	29	Iraba, Louis W.	112	Roy Watch Case Co.....	84
issett Jewelry Co.	33	Hull Bros. Umbrella Co.	74	Rudolph & Snedeker	97
istlan Bros. & Co.....	14	Illinois Watch Co.	70	Rumpp, C. F., & Sons.....	106
ites & Bacon	15	International Gem Co.	46	Saunders, Meurer & Co.....	54
erge, J. & H.	112	Irons, Joseph	30	Schlehr, Louis G.	26
illings, Chester, & Son.....	50	Irving Cut Glass Co.....	106	Sessions Clock Co.	96
ishop, R. W.	46	Jacot Music Box Co.....	112	Shepard Mfg. Co.....	19
ackinton, R., & Co.....	13	Janitschek Co.	60	Simmons, R. F., Co.....	22
olles, Wm., Co.....	106	Jeanne, F. A.	48	Smith, Alfred H., & Co.....	46
orrell & Vitelli	56	Jorgeson, F. C., & Co.....	112	Smith, Frank W., Co.....	16
owden, J. B., & Co.....	29	Juergensen, Jules	97	Smith, Wm., & Co.....	30
radley Polytechnic Institute.....	96	Kahn, L. & M., & Co.....	42	Snow & Westcott Co.	25
riggs, D. F., Co.....	12	Keller Jewelry Mfg. Co.....	26	Sohn & Hyman	52
riggs Piano Co.	112	Kent & Woodland	26	Solidarity Watch Case Co.....	18
irter, Howe & Co.....	25	Ketcham & McDougall.....	32	Spencer, E. L., Co.....	33
atham National Bank	66	Keystone Watch Case Co.....	92	Star Watch Case Co.....	6
hicago Art Metal Works	48	Kirby, H. A.	64	State Bank	66
opard Frères Co.	28	Kohlbusch, Herman, Sr.	104	Steiner, Louis	106
ncinnati Gold & Silver Refining Co.....	28	Kohn, Alois, & Co.....	25	Stern Bros. & Co.....	48, inside back cover
onley & Straight	111	Krementz & Co.	23	Stern & Corn	33
ottle, S., Co.....	27	Larter & Sons	40	Sternau, S., & Co.....	12
rees & Court	58	Lederer, S. & B., Co.....	32	St. Louis Watchmaking School.....	96
ohn, M.	32	Leiman Bros.	104	Street, Geo. O., & Sons.....	28
ross & Beguelin	52, 64	Lelong, L., & Bro.....	104	Sussfeld, Lorsch & Co.....	108, 110
rossman Co.	48	Lewy & Cohen	29	Swartchild & Co.	76
ouch & Fitzgerald.....	29	Lisner, D., & Co.....	18	Tavannes Watch Co.	86
alman, C.	111	Lissauer & Co.	52	Title Guarantee & Trust Co.....	66
ay, Clark & Co.....	26	Lorsch, Albert, & Co.....	42	Trout, Charles L., & Co.....	28
eacon, Louis J.	25	Lowe, Edwin, & Co., Inc.....	30	Turner, John F.	76
ederick's, James H., Sons.....	58	Mabie, Todd & Co.....	84	Untermeyer-Robbins Co.....	60
ixon, Wm., Inc.	110	Maintien Bros. & Elliot.....	33	Urich, S.	83
oran, Bagnall & Co.....	32	Market & Fulton National Bank.....	66	U. S. Smelting & Refining Works.....	110
oran, J. C., & Sons.....	78	Marson, A.	84	Van Dam, Eduard	44
orflinger, C., & Sons.....	106	Mercantile National Bank.....	67	Van Dusen & Stokes Co.....	17
raper, O. M., Estate.....	35	Milner, Fuller & Whiting Co.....	34	Wachenheimer Bros.	30
rbois Watch Case Co.....	98	Mount & Woodhull	52	Wadsworth Watch Case Co.....	9
ueber-Hampden Watch Mfg. Co.....	10	Myers, J. A.	84	Wagenföhr, Charles	46
unn, T. J., Co.....	32	Myers, S. F., Co.....	30	Waite-Thresher Co.	35
urand & Co.	24	New England Watch Co.....	96	Waldron & Carroll	31
ichberg & Co.....	58	New York Tortoise Shell Co.....	108	Waltham Clock Co.	97
isenmann Bros	50	Nissen, Ludwig, & Co.....	50	Waltham Watch Co.	88
igin National Watch Co.	90	Noel, Rudolph, & Co.....	46	Washburn, C. Irving	32
. P. H. Chain Catch.....	34	Oneida Community, Ltd.....	Outside back cover	Wells, Chester H.	34
ahys, Joseph, & Co.....	3	Oppenheimer Bros. & Veith.....	44	Wendell & Co.....	7
eldenheimer, Louis	76	Oskamp-Nolting & Co.....	76	Wheeler, Hayden W., & Co.....	48
oster, Theodore W., & Bro. Co.....	38	Osmers-Dougherty Co.....	27	Whiting & Davis	15
reund, Henry, & Bro.....	17	Osmun Parker Mfg. Co.....	24	Whiting, F. M., & Co.....	36
riedlander, R., L. & M.....	44	Ostly & Barton Co.....	16	Whiting Mfg. Co.....	11
arraund & Griser	48	Owanda Cut Glass Co.....	106	Wightman & Hough Co.....	30
ibson Building	78	Papazian, A. D.	96	Wolfsheim & Sachs	31
illette Sales Co.	37	Penfold, Wm. C., Co.....	86	Wollstein, L. & M.	110
oldsmith, Leo.	48	Peninsular Eng. Co.....	19, 20	Wood, J. R., & Sons.....	4, 5
oodfriend Bros.	54	Pitcairn, W. S.	108	Zarembowitz, A.	104
orham Co.	62	Potter, E. A., Co.....	34	Zimmern, Henry, & Co.....	111
rifouf, August	111	Potter & Buffinton Co.	31		

Special Notices.

Payable invariably in advance.

Rates 75c. per insertion for notices not exceeding 25 words; additional words, 2c. each.

SITUATIONS WANTED, 1c. a word each insertion; minimum charge, 25c.

Heavy type, 5c. a word; minimum charge, \$1.25. Display cards, \$2.00 per inch.

In all cases, if answers are to be forwarded, 10c. extra to cover postage must be enclosed.

All answers to advertisements addressed care The Jewelers' Circular-Weekly, should be sent to the New York Office, unless the Chicago Office is specifically mentioned.

Situations Wanted.

WANTED, position in jewelry store by first class engraver. Address "A. F., 3819," care Jewelers' Circular-Weekly.

JEWELER, order worker and first class repairer, desires position. Address "H., 3954," care Jewelers' Circular-Weekly.

WATCHMAKER and engraver, 30 years' experience, no jewelry repairs; good references. J. Lane, 1650 N. Clark St., Chicago, Ill.

POSITION desired by a gilder, capable of making all colors, understands polishing and lapping. Address "N., 3824," care Jewelers' Circular-Weekly.

COMPETENT clockmaker desires position; first class mechanic; has up-to-date tools; reference. Address "L., 3980," care Jewelers' Circular-Weekly.

MARRIED MAN would like a repairing job in store or shop; can melt and do casting, also setting. Address "P., 3976," care Jewelers' Circular-Weekly.

EXPERIENCED SALESMAN desires position outside of New York; distance no object; best references. Address "T., 3958," care Jewelers' Circular-Weekly.

BY FIRST CLASS watchmaker, 20 years' experience; competent on fine and complicated work; full set of tools; best of references. Wm. H. Eaton, Groton, Conn.

MANUFACTURING JEWELER, stone setter and repairer wishes position; best of reference; can wait on trade. Address "A., 3989," care Jewelers' Circular-Weekly.

POSITION WANTED by young lady with 12 years' experience in jewelry manufacturing and loose goods business. Address "F., 4004," care Jewelers' Circular-Weekly.

EXPERIENCED jewelry engraver; can assist as jewelry repairer, salesman, etc.; first class references; New York preferred. "T., 3970," care Jewelers' Circular-Weekly.

FIRST CLASS diamond setter desires position with good firm; A1 references; no objection to going out of town. Address "P., 3870," care Jewelers' Circular-Weekly.

FIRST CLASS watchmaker, with good tools and references; willing to do clock work; New York City or vicinity preferred. "M. W., 4014," care Jewelers' Circular-Weekly.

YOUNG MAN, neat appearance, wishes position as salesman in retail jewelry store; five years' experience; A1 references. Address "T., 4009," care Jewelers' Circular-Weekly.

SITUATION WANTED as assistant watchmaker; four years' experience on watch, clock and jewelry repairing; age 24, single; best references. Address F. Berger, Newark, N. Y.

POSITION WANTED by young man with five years' experience in retail jewelry store, age 23, single, good appearance and no bad habits. "E., 3994," care Jewelers' Circular-Weekly.

JEWELRY and watch repair clerk desires position with a high class jewelry house; many years' experience and excellent references. "T., 4001," care Jewelers' Circular-Weekly.

JEWELER, age 28, seeks position as an all around jobber, and able to do new work and some setting; has five years' reference. Write to L. Klein, 217 E. 83d St., New York.

YOUNG MAN, 20, jeweler of six years' experience, can do new work and repairing, desires position at bench or in office; reference, Emil Schenck, 2863 Fulton St., Brooklyn, N. Y.

EXPERIENCED ENGRAVER, does ordinary stationery die work, all styles of lettering and monograms; a rapid and thorough workman. "Engraver," 129 N. Perry St., Johnstown, N. Y.

ONE of the most thorough workmen in the south desires position with first class house appreciating fine service; can manage entire business. "Reliable, 3965," care Jewelers' Circular-Weekly.

YOUNG MAN, 22, having six years' experience in jewelry trade, wishes position in office, factory or store; good repairer; hustler; A1 reference. "L., 3979," care Jewelers' Circular-Weekly.

WATCHMAKER of great ability, long experience on all kinds of watches, expert on all English and complicated watches; best reference. Address "G., 4005," care Jewelers' Circular-Weekly.

YOUNG MAN, 24, desires position with wholesale jewelry firm; five years' retail experience; best references as to honesty and ability. Address "O., 4008," care Jewelers' Circular-Weekly.

SITUATION WANTED by first class manufacturing and jobbing jeweler, also stone setter and all around man, with best of references. Address "M., 4011," care Jewelers' Circular-Weekly.

WATCHMAKER of many years' experience on high grade watches and in serving on trade, desires position with first class jeweler; no engraving. "M." 22 Moreland St., Roxbury, Mass.

JEWELER, experienced, all around man, platinum diamond moulder, new and repair work, can also do setting, wishes position; best of references. John Berkowitz, 679 N. Artisan Ave., Chicago, Ill.

BY YOUNG MAN, with four years' experience as salesman, clock and jewelry repairer; speaks German; references furnished; salary, \$12 a week to start. Address F. E. Rohloff, R. R. 5, Appleton, Wis.

WANTED, position as salesman or manager with retail jeweler; 15 years' experience, good references; married, 28; good address; I can fill the bill. J. P. Turner, 1729 Edmondson Ave., Baltimore, Md.

ENGRAVER, young man, desires position with first class engraver, or an opportunity to learn watch work; good script letterer; samples on request; A1 reference. "D., 3602," care Jewelers' Circular-Weekly.

YOUNG married man wants permanent position in large retail store; watchmaker, optician and plain diamond moulder; at present have charge of branch store. Address "S., 3972," care Jewelers' Circular-Weekly.

A1 WATCHMAKER, engraver and graduate optician, 21, wishes position at once; no bad habits; experienced; have tools and trial case; \$15; best reference given; east preferred. "U., 3961," care Jewelers' Circular-Weekly.

FIRST CLASS jeweler on gold and platinum work, setter and plain engraver, an all around workman, wishes position in shop or factory; best of references furnished. Address "K., 3998," care Jewelers' Circular-Weekly.

WATCHMAKER, young man with full set of tools, having 12 years' experience and some knowledge of optics, wants position as watchmaker; speaks German and some English. Address "D., 3991," care Jewelers' Circular-Weekly.

YOUNG MAN, 25, first class experience on fine jewelry, new work, in platinum and gold, desires position; A1 reference; able to take care of a shop; no objection to going out of town. Address "B., 3964," care Jewelers' Circular-Weekly.

EXPERT WATCHMAKER, good jeweler and engraver, capable salesman, experienced on complicated watches, French clocks, etc., open for a position; first class references. Address "Thomas, 4017," care Jewelers' Circular-Weekly.

WATCHMAKER, 15 years' experience on high grade work, competent to take charge, good salesman, can do plain engraving and optical work, at present in charge of department, wishes to make change. "W., 4016," care Jewelers' Circular-Weekly.

FIRST CLASS watchmaker, 35, also optician and salesman, 22 years' retail store experience, able to do anything demanded of a first class watchmaker, desires position; willing to go anywhere on trial; state wages. Address "Competent, 3986," care Jewelers' Circular-Weekly.

WATCHMAKER, first class, open for engagement; 30 years' experience; thoroughly competent on high class work, all kinds of American and Swiss watches; best New York references; New York preferred; only good houses need apply. Address "V., 4013," care Jewelers' Circular-Weekly.

A1 WATCHMAKER, fine engraver and graduate optician, 23 years' experience; several years in present position as first man in large store; do not repair clocks or jewelry; would not go east of Indiana; \$18 to \$20; first class references. Address "S. J., 3862," care Jewelers' Circular-Weekly.

WATCHMAKER, an A1, all around man of 40, also jeweler, diamond setter, engraver, optician and salesman; 16 years' experience, 14 years as manager, buyer and all around man in one store; competent to take charge of store or any department; no bad habits, best of bank references and otherwise, desires permanent position at once; state requirements and best salary in first letter. Address P. O. Box 335, Burlington, Ia.

WATCHMAKER, having 29 years' experience, as foreman in best Swiss and French factories; expert, particularly in precision of watches; now employed by Henry Birks & Sons, jewelers, Montreal. Apply to F. de Paris, 157 Amherst St., Montreal, Que.

Side Lines Wanted.

LONG EXPERIENCED salesman, good trade in Chicago, and surrounding territory, is open for line of jewelry for retail trade; commission; eastern house. Address "W., 3982," care Jewelers' Circular-Weekly, 301 Heyworth Bldg., Chicago, Ill.

WANTED, a jewelry or kindred line for the jobbing trade; middle western territory; have own office. Address I. S. Richter, 1006-7 Heyworth Bldg., Chicago, Ill.

Help Wanted.

NEW YORK City retail jewelry house requires competent watchmaker. "L., 4024," care Jewelers' Circular-Weekly.

WANTED, watch case repairer; state age, experience and by whom you were last employed. Address Drawer No. 1127, Kansas City, Mo.

AT ONCE, competent man as watchmaker, who can do some engraving preferred; splendid opportunity. C. D. Barnes Co., Gowanda, N. Y.

WANTED, young man, about 17, with best references; must live in Brooklyn. Wm. Wise & Son, jewelers, Flatbush Ave. and Fulton St., Brooklyn, N. Y.

FIRST CLASS jobbing jeweler, competent to take charge of a trade repair shop; state salary and experience in first letter. Josten Mfg. Co., Owatonna, Minn.

WANTED, salesman, experienced, with trade in New York and vicinity, for watches and jewelry. permanent position for right man. Address "I., 4023," care Jewelers' Circular-Weekly.

FIRST CLASS watchmaker, optician and good salesman wanted in retail jewelry store; permanent position; only an A1 man, well recommended, need apply. B. Raff, 453 Sixth Ave., New York.

WANTED, an experienced man who can do good watch work and nice engraving and is a good salesman; situation in New York State; good salary. Address "Jeweler, 3960," care Jewelers' Circular-Weekly.

WANTED, watchmaker, who can also do some jewelry work and engraving, expert workman; steady and reliable all around man; must have finest appearance; steady position; \$30 weekly. Keppeler, jeweler, Anaconda, Mont.

DESIRABLE POSITION in New York City to competent American watchmaker and engraver, with ability as salesman; must have own tools and highest references. Address "N. Y. C., 4012," care Jewelers' Circular-Weekly.

SALESMAN WANTED for the south to carry as a side line high grade ladies' gold chains, on commission, for old established firm; only man with trade and experience need apply. "Gold Chain, 3966," care Jewelers' Circular-Weekly.

HELP WANTED.—Continued.

YOUNG MAN, experienced in watch material and jewelers' supplies, to take full charge of business in west; opportunity for acquiring an interest for right man. Address "H., 3928," care Jewelers' Circular-Weekly, 501 Heyworth Bldg., Chicago, Ill.

SALESMAN, acquainted with retail jewelry trade in the south and east of Buffalo, to sell paper boxes and velvet display goods for manufacturer; good opportunity for right man; state experience and references. Address "B., 3990," care Jewelers' Circular-Weekly.

WANTED, by first class house in large Texas city, first class jeweler and engraver on new work and repairs; permanent position, good salary; send samples of engraving and copy of references in first letter. Address "L., 3694," care Jewelers' Circular-Weekly.

WE HAVE a position open for a good, active, reliable man who understands the pawnbroking business thoroughly; must be a good salesman and understand values in general; salary no object; full particulars in first application. Goldwater's, 841 Broadway, Oakland, Cal.

WANTED, men to earn \$25 to \$150 per day, others are now earning it, you can do likewise; if you desire to increase your salary and elevate yourself let us send you a book free, giving some valuable information how to become a professional auctioneer. Write or call at the Chicago School of Auctioneering, Dept. G., 816 Ashland Block, Chicago, Ill.

ALL WATCHMAKER wanted, thoroughly competent for railroad and complicated work; salesman, strictly sober and reliable, capable of taking charge of store if required; steady position and first class salary to right man; position open any time from now to July 1; give full particulars, references and photo with first letter Andrew Wilson, Winfield, Kans.

Business Opportunities.

RETIRING FROM BUSINESS; will sell my stock of high grade jewelry amounting to about \$2,000, or will trade for lots of diamonds. Rossi, 20 Maiden Lane, New York.

WANTED TO BUY a jewelry store for spot cash, or any part of your stock; deal with a man with a rating and reputation. Dan I. Murray, 3 Maiden Lane, New York.

FOR SALE, first class established metal novelty plant, complete; plating room, moulds, motors, etc.; in condition to start business; very cheap. Address Box 3987, care Jewelers' Circular-Weekly.

FOR SALE, on account of sickness, an enameling shop for jewelry, established for 25 years; would also accept a competent man for partner instead; location, Newark, N. J. Address "E., 3757," care Jewelers' Circular-Weekly.

FOR SALE, jewelry and musical store in best town of South Carolina; population 2,000, with county seat, 30,000; invoice can be reduced to \$1,500; repairs cover all expenses; best chance for right man. "S., 3908," care Jewelers' Circular-Weekly.

BEST LOCATION in Baltimore, opposite Washington and Baltimore and Annapolis terminal station, established jewelry and optical store; clean, up-to-date stock; want to retire from the jewelry business. Address O. D. Wareheim, 101 N. Liberty St., Baltimore, Md.

ADVERTISER would invest \$15,000 to \$20,000 in established, paying, retail jewelry business, in city of 100,000 or over; prefers to purchase outright, but might consider part interest with management, for which advertiser is well fitted. "E., 3937," care Jewelers' Circular-Weekly.

RAISE MONEY QUICK by sending your diamonds and watches to me; liberal prices paid; reference R. G. Dun & Co., or National Banks. M. Iralson, 410 Masonic Temple, Chicago, Ill.

JEWELRY BUSINESS in growing manufacturing town in Massachusetts of over 7,000 inhabitants; ill and old age; want to retire; stock and fixtures about \$2,500; can reduce to any reasonable amount; grand opening for watchmaker and optician. Address "Opportunity, 3906," care Jewelers' Circular-Weekly.

\$25 TO \$150 PER DAY is yours; others are now earning it, you can do likewise; if you desire to increase your salary and elevate yourself let us send you a book free, giving some valuable information how to become a professional auctioneer. Write or call at the Chicago School of Auctioneering, Dept. G., 816 Ashland Block, Chicago, Ill.

HIGHEST cash prices paid for watches, diamonds and jewelry; quick and liberal returns; all business confidential; bank references. E. Noel, 552 E. 46th Place, Chicago, Ill., Telephone Blue, 995.

FOR SALE, jewelry store, established seven years, located in Los Angeles, Cal.; a rare opportunity for a good watchmaker to step right into a good paying business; this store has a fine reputation and enjoying a high class trade; reason for selling, poor health and the doctor advises to quit; only about \$1,100 required; fullest investigation urged. Address "Snap, 3955," care Jewelers' Circular Weekly.

WELL BOUGHT is not only half sold, but beats the other fellow as he sleeps; you can make money if you will get a selection package of my jobs bought at government and trade auction sales; they consist of real corals, ambers, jets, gun metals and novelties of all kinds, also watches and diamonds; all sold under the regular price; sent on memo. bills to jewelers with a rating; select what you want, return the rest; place cash in box for what you keep. Dan I. Murray, 3 Maiden Lane, New York.

DO YOU NEED MONEY? If so, send your diamonds and watches to me and get quick and liberal returns; highest cash prices paid for entire jewelry stocks; will send our representative if necessary; business confidential; National Bank references. H. Schwartz, 807 Chicago Savings Bank Building, Chicago, Ill.

DO YOU WISH TO RETIRE? Why not turn your entire store or surplus stock into cash? We pay the highest prices, also advance liberal cash amounts on stocks; communicate with us before consulting others; we act quick and strictly confidential. Brooklyn Purchasing Syndicate, 608 Broadway, Brooklyn, N. Y., Telephone, 2328 Williamsburg.

To Let.

TO LET, a part of a light office; reasonable. Morrison Bros., 41 Maiden Lane, New York.

TO LET, light office, ninth floor. Apply between 2 and 4, J. F. Braun, 37 Maiden Lane, New York.

TO LET, desk room, from May 1. T. G. Frothingham & Co., Room 1501, 9-11 Maiden Lane, New York.

TO LET, a desirable office, 170 Broadway, with or without partitions; liberal reduction in rent. Particulars, Room 1003, 527 Fifth Ave., New York.

PART OF FINE, large office, suitable for silver-smith or jeweler; ample space for show cases; reasonable rent; possession immediately. Room 53, 3 Maiden Lane, New York.

FOR RENT, repair shop in New York City for jobbing jeweler; dynamo and complete fixtures already installed; excellent location and good opportunity for practical man. "Repair, 3956," care Jewelers' Circular-Weekly.

TO RENT, May 1, desk room on 12th floor front of new Silversmiths' building, to reliable manufacturer who caters to fine retail trade. Apply to the Chas. M. Robbins Co., Room 1501, Jewelers' Bldg., 9 Maiden Lane, New York.

TO LET, third floor of building in Newark, N. J., opposite Market St. station, with steam heat, power and elevator service; size of floor, 115 ft. by 39 ft.; well lighted and specially adapted for manufacturing jewelers. Address Cyrus Currier & Sons, 365 Market St., Newark, N. J.

For Sale.

FOR SALE, a mechanical engraving machine in first class condition. Address "N. P., 4020," care Jewelers' Circular-Weekly.

FOR SALE, a double die, new, for Spanish-American War Veterans' charms; worth \$55, sell for \$25. T. C. Gay, 105 Hamilton Ave., Brooklyn, N. Y.

JADE; for sale, one block of New Zealand jade, 1,400 lbs., highly crystallized; will cut to suit. Address M. Pollock, B-21 Produce Exchange, New York.

FOR SALE, safes, counters, office partitions, desks, etc. A. Lounsbury & Son, 9 and 11 Maiden Lane, New York.

UP-TO-DATE fixtures from our store, 219 Broad St., Elizabeth, N. J.; safe, eight show cases, one horseshoe case, wall case, two large mirrors, watch benches, complete optical outfit, partitions, gas fixtures, with stock and lease of store or without. Write or apply to Rubenstein Bros., 14 Maiden Lane, New York.

FOR SALE, machinery, hydraulic press, lathes, drills, lapps, tools, cutters, foot presses and dies, comprising a lot of absolutely new ones. A. Lounsbury & Son, 9 and 11 Maiden Lane, New York.

Wanted to Purchase.

WANTED to buy, a well paying, small jewelry store near New York City. Address "V., 3967," care Jewelers' Circular-Weekly.

WANTED TO PURCHASE, a large watch sign, 60 to 72 inches in diameter; state condition, price, etc. J. F. Carr, Portsmouth, O.

Miscellaneous.

I WOULD LIKE to know the present whereabouts of one Thomas Gwaltney, a watchmaker. Address P. W. Caine, 567 Pearl St., Beaumont, Tex.

FOREMAN WANTED

for factory, manufacturing sterling silverware. A party is wanted experienced in all details of getting out hollow ware, flat ware, silver jewelry and novelties. A good mechanic with executive ability will be liberally dealt with. Address in confidence, stating full particulars, if employed at present, salary desired and age.

Address "STERLING," 794 Broad St., Newark, N. J.

10 TO 20 PER CENT. SAVED!

M. L. Jalonack, jewelry auctioneer and diamond expert, will pay you from 10 to 20 per cent. more for your stock of jewelry, watches and diamonds than any other buyer of stocks. Send me your surplus stock and I will send draft on First National Bank of Chicago. If my price isn't satisfactory I will return the goods on receipt of draft. Consult me about turning your stock into money quickly. All business strictly confidential. Write, call or telephone M. L. JALONACK, 5339 PRAIRIE AVE., CHICAGO, ILL. Long Distance Phone, Gray 5234.

Do You Need Money?

I will buy your entire store and stock, large or small, as it stands, for spot cash, or send me your surplus Diamonds and Watches and receive prompt returns. If necessary my representative will call. Quick action and business strictly confidential guaranteed.

HENRY P. EPSTEIN, 280 State St., Chicago, Ill.

WANTED WATCHMAKERS everywhere to know about

URICH Perfect Fitting CASE SCREW WASHER

Will hold movements securely in their case, even when shoulder is worn away. Fits perfectly under head of screw, and is almost invisible. Prices:
Single Dozen, - - - - - 15c
4 Doz. Package, assorted, - - - 50c
Gross, - - - - - \$1.50 Pat. app. for



For sale at all Jobbing and Material Houses.
S. URICH, P. O. Box 1942, New York City

Practical Course in Adjusting

By THEO. GRIBI,

COMPRISING

A review of the laws governing the motion of the balance and balance spring in watches and chronometers, and application of the principles deduced therefrom in the correction of variations of rate arising from want of isochronism, change of position and variation of temperature.

ELUCIDATED AND DEMONSTRATED

by original experimental researches in the actual problem, never before published, showing the causes that are operative in the variation of rate, and leading to correct remedies. To which have been added chapters on

Published Price, \$2.50.

SPECIAL REDUCED PRICE, \$1.50,
Post prepaid.

250 pages, including 18 diagram plates; Fine Paper; Large Type; Clear Illustrations; Systematically arranged; Solid Binding.

THE JEWELERS' CIRCULAR PUB. CO.

Publishers

11 John St., cor. Broadway, New York.

THE Ægis Case

(PATENTED)



THE ÆGIS is a new creation in gold case making. The center and bezel are in one. Instead of having the ordinary Cap, this case is provided with a rigid metal movement Cup, held friction tight in position. This Cup gives protection to the movement such as cannot be secured with the conventional jointed cap, while dust is thoroughly excluded from the front by means of the one-piece center and bezel.

MADE ONLY BY

ROY WATCH CASE CO.

21-23 MAIDEN LANE
NEW YORK

San Francisco Office, 704 Market Street

S. F. MYERS BLDG.
47-49 Maiden Lane, N. Y.

For Rent

A few choice, light and
very desirable offices

Moderate Rentals

Details of

J. A. MYERS

On Premises

REMOVAL NOTICE

MABIE, TODD & CO.

Gold Pens

PENCILS, HOLDERS AND CASES
SWAN FOUNTAIN PENS

HAVE REMOVED TO
SILVERSMITHS BUILDING
15-17-19 Maiden Lane, New York

ARTHUR MARSON

INC.

MAKERS OF

Swivels, Spring Rings, Snaps and
Specialties in the Line, in GOLD
and PLATINUM

Manufacturers of the

SMALLEST SPRING RING

on the market for Neck Chains

SEND FOR SAMPLES

23 MARSHALL ST., NEWARK, N.J.

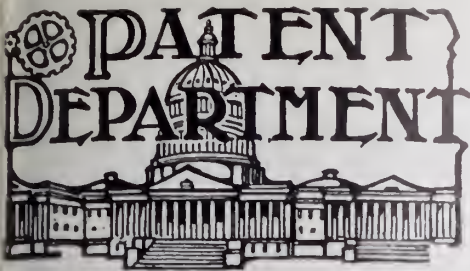

[IN WHICH IS CONTAINED A LIST OF THE LATEST PATENTS GRANTED BY THE UNITED STATES AND GREAT BRITAIN, THE UNITED STATES PATENTS THAT HAVE EXPIRED AND THE REGISTERED TRADE-MARKS.]

UNITED STATES PATENTS.

ISSUED APRIL 7, 1908.

883,707. BELT-BUCKLE. HENRY W. FISHEL, New York, assignor to himself and Theodore H. Fishel, copartners, trading as Fishel, Nessler & Co., New York. Filed May 29, 1907. Serial No. 376,245.

A belt-buckle having two members provided with means for detachably securing them together, one of the members being provided with means for



adjustably securing the belt comprising two substantially unresilient parallel flat bars located normally in the same plane of which one is flexible so as to be bent to secure the belt after it is passed about the other bar.

883,992. ELECTRIC TIME-INDICATING DEVICE. WILLIAM F. WENTZ, New York. Filed Dec. 22, 1904. Serial No. 237,906.

In a time-indicating device, a frame having a plate which is perforated, a drum horizontally journaled beneath said plate, said drum having pins

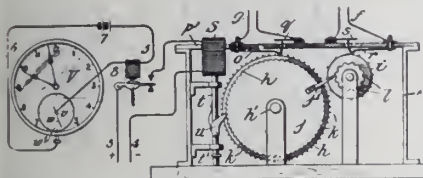

upon its periphery, springs fixed to the under side of said upper portion of the frame and lying in the path of said pins, said springs being bent to project through said perforations in the plate, contacts on the other side of said plate in the path of said springs whereby the terminals are exposed for the circuit connections, and means for intermittently imparting a movement of rotation to said drum.

884,054. COLLAR AND CUFF BUTTON. EDGAR C. TREES, Denver, Colo. Filed March 16, 1907. Serial No. 362,736.

A button of the kind described comprising a base, a standard carried by said base, the standard having converging interlocking opposite sides crimped

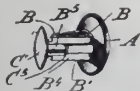

to form a socket, the sides being cut to form tongues, a shank extending into the socket and engaged by the tongues, and a head on the shank.

884,092. COLLAR-BUTTON. CHARLES A. KIEF-



FER, Swampscott, Mass. Filed June 6, 1907. Serial No. 377,525.

The combination with a collar button having a pivoted bead, of a member pivoted to the shank of

the button, said member having a pivoted leaf connected to its free end and adapted to be retained closed by the head of the button.

DESIGNS.

39,243. BROOCH, BUTTON, OR BUCKLE-PLATE. ARTHUR C. STONE, Providence, R.



I. Filed Feb. 13, 1908. Serial No. 415,759. Term of patent 3 1/2 years.

39,244. BROOCH, BUTTON, OR BUCKLE-PLATE. ARTHUR C. STONE, Providence, R.



I. Filed Feb. 13, 1908. Serial No. 415,760. Term of patent 3 1/2 years.

39,245. LOCKET. BENEVOICT B. LEDERER, Providence, R. I., assignor to the S. & B. Lederer



Co. Filed Jan. 25, 1908. Serial No. 412,677. Term of patent 3 1/2 years.

39,246. LOCKET. ERNEST H. LOHRMANN, Providence, R. I., assignor to the Wightman &

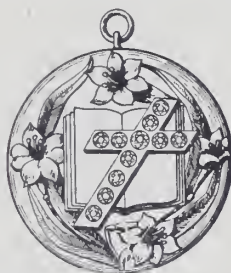

Hough Co. Filed Jan. 25, 1908. Serial No. 412,678. Term of patent 3 1/2 years.

39,247. FINGER-RING OR SIMILAR ARTICLE. MEYER L. ROBBINS, New York. Filed



Jan. 30, 1908. Serial No. 413,492. Term of patent 7 years.

39,248. BEAD FOR NECK-CHAINS OR SIM-



ILAR ARTICLES. LOUIS E. F. WACHTER,

Hartford, Conn. Filed Jan. 24, 1908. Serial No. 412,522. Term of patent 7 years.

39,249. HANDLE FOR SPOONS, FORKS OR SIMILAR ARTICLES. WILLIAM C. COOMAN,



Providence, R. I., assignor to the Gorham Mfg. Co., Providence, R. I. Filed Feb. 24, 1908. Serial No. 417,610. Term of patent 14 years.

UNITED STATES TRADE-MARKS.

[The following trade-marks have been adjudged entitled to registration under the Act of Feb. 20, 1905, and are published in compliance with Section 6 of said act. Said section provides:

"Any person who believes he would be damaged by the registration of a mark may oppose the same by filing notice of opposition, stating the grounds therefor, in the Patent Office, within 30 days after the publication of the mark sought to be registered, which said notice of opposition shall be verified by the person filing the same before one of the officers mentioned in Section 2 of this act. If no notice of opposition is filed within said time the commissioner shall issue a certificate of registration therefor, as hereinafter provided for."

Marks which are stated to have been "Used 10 years" are registrable under the last proviso of Section 5 of said act, which is as follows:

"And provided further, that nothing therein shall prevent the registration of any mark used by the applicant or his predecessor, or by those from whom title to the mark is derived, in commerce with foreign nations or among the several States, or with Indian tribes, which was in actual and exclusive use as a trade-mark of the applicant or his predecessor from whom he derived title for 10 years next preceding the passage of this act."]

PUBLISHED APRIL 7, 1908.

Ser. No. 32,995. (CLASS 27. HOROLOGICAL INSTRUMENTS.) ELGIN NATIONAL WATCH Co., Elgin and Chicago, Ill. Filed Feb. 25, 1908. Used 10 years.

B. W. RAYMOND

Particular description of goods.—Watch movements.

TRADE-MARKS REGISTERED APRIL 7, 1908.

68,377. WATCHES, WATCH CASES AND WATCH MOVEMENTS. AMERICAN-SWISS WATCH Co., New York.

Filed Dec. 20, 1907. Serial No. 31,862. Published Feb. 4, 1908.

68,397. TIME-RECORDING CLOCKS AND DIALS THEREFOR. NEWMAN CLOCK Co., Chicago.

Filed May 11, 1907. Serial No. 27,304. Published Feb. 4, 1908.

68,421. CERTAIN JEWELRY AND MINIATURE-PHOTO FRAMES. THE GOPHIR DIAMONO Co., Ltd., London, Eng.

Filed Aug. 15, 1905. Serial No. 11,671. Published Feb. 4, 1908.

68,467. DIAMOND-POLISHERS' WHEELS. HENORIK FREDERIK MAASDAM, Netherlands.

Filed Jan. 11, 1907. Serial No. 11,671. Published July 9, 1907.

UNITED STATES PATENTS HAVE

[Reported especially in THE JEWELERS' CIRCULAR—WEEKLY by Washington, D

449,672

449,673

449,674

449,675

449,676

WM. C. PENFOLD CO.

No. 35 MAIDEN LANE, NEW YORK

LARGEST EXCLUSIVE WATCH JOBBERS IN NEW YORK OF

Dueber-Hampden Watches Dueber Cases—Hampden Movements

A Complete Line Always on Hand. Mail Us Your Orders

A.W.C.CO



14K.
C-429

Liberality and Economy Combined

Unusual liberality is shown in the quantity of gold employed in the construction of our inexpensive cases, while the decorations denote an inviting artistic generosity.

They are built to enlist the attention of the man with an economical streak and a knowledge of "what's what" in pocket horology.

Sold by us directly to you.

American Watch Case Co.

9-11-13 Maiden Lane

New York

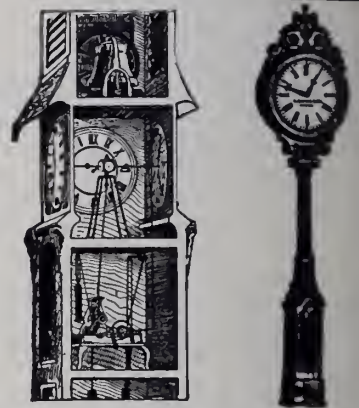

MAKERS OF

Tower and Street Clocks

For particulars write us, mentioning The Jewelers' Circular-Weekly.

E. HOWARD CLOCK CO.,
ESTD 1842. BOSTON, MASS., U. S. A.



AN EXAMPLE OF A GREAT ACHIEVEMENT IN THE MANUFACTURE OF IMPORTED WATCHES IS EVIDENCED IN

"Cavannes" Movements and "Cyma" Watches

WHY?

Because all features heretofore existing that have been an obstacle to the modern watchmaker have been eliminated—being brought about by the introduction of automatic machinery in the manufacture of these goods, and the concentration of our mammoth factory on a modern scale, enabling us to furnish "FINISHED MATERIAL" ready to use.

"TAVANNES" movements and "CYMA" watches give most satisfactory results when exposed to the extreme influence of TEMPERATURE, ELECTRICITY or MAGNETISM.



ES WATCH COMPANY

ADOLPHE SCHWOB, Sole Agent for the U. S.
and 4 MAIDEN LANE, NEW YORK

704 Market Street
San Francisco

FROM HAIR. MARGARET I. WALDRON, St. Joseph, Mo.

- 449,791. POCKETBOOK. A. Y. ANDREWS, Philadelphia, Pa.
- 449,799. POCKETBOOK. FREDERICK LIEKER, New York.
- 449,817. GARMENT-SUPPORTER. G. C. KIBBE, Jr., New York.
- 449,885. WATCH-BOW FASTENER. C. F. MORRILL, Boston, Mass.
- 449,915. STOP-WATCH. L. E. PIQUET, Brassus, Switzerland.
- 449,951. SUSPENDER-BUCKLE. CHARLES SCHWARTZ, Philadelphia, Pa.
- 450,066. INKSTAND. H. S. S. FOOKS, Brighton, England.
- 450,110. BUCKLE. W. E. SMITH, Bridgeport, Conn., assignor to B. Goodman, New York.

Design issued April 9, 1901, for 7 years.

- 34,341. SPOON. S. J. LARGE, Bristol, Conn., assignor to the Bristol Brass & Clock Co., same place.

Designs issued Oct. 4, 1904, for 3½ years.

- 37,156, 37,157 and 37,158. CLOCK CASE. G. H. RHYNDANCE, New Haven, Conn., assignor to the New Haven Clock Co., same place.

BRITISH PATENTS.

(ABRIDGMENTS OF SPECIFICATIONS, 1906, FROM *The Illustrated Official Journal.*)

ISSUE OF MARCH 25, 1908.

- 27,135. CLOCKS, ETC. C. LEGG, London, S. W. Nov. 29.

Dials.—The minutes of the hour-circle and the seconds of the minute-circle on a clock or watch dial are differentiated so as to be distinguishable at a glance. As shown in Fig. 1, the second, fourth, seventh, ninth, etc., minutes or seconds, both past and to the starting point, are filled in

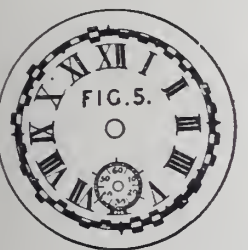
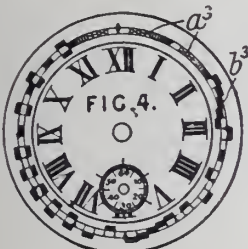
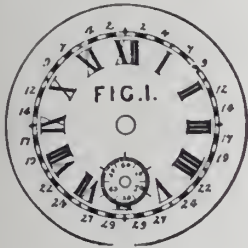

with black, silver, gold, or various dark colors. Some of the spaces may be wholly or partly displaced in a radial direction, as shown in Fig. 5. As shown in Fig. 4, the spaces b³ may be displaced symmetrically, or they may be filled with geometrical designs a³ and for greater effect have one or more concentric rings in various colors, either internally or externally to the hour and minute circles.

- 27,155. STUDS. A. F. WILKINSON and R. FILTNESS, both of Brighton. Nov. 29.

A shirt or blouse and collar stud is provided

with two blades to prevent it from falling out.

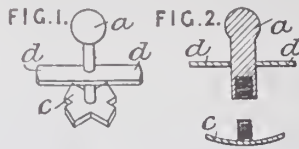

The blades d extend laterally beyond the width of the top a and bottom c of the stud.

- 27,331. WATCHES, ETC. J. BAILEY, Birmingham. Dec. 1. Period for granting patent not yet expired.

Cases.—The watch is inserted in a ring A of india-rubber or other elastic material having an aperture B for the pendant. The ring, being of slightly smaller diameter than the watch, fits

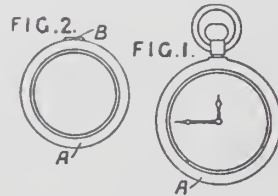

tightly so as to prevent the entry of water or dust at the joints and hinges. According to the Provisional Specification, the invention is applicable to clocks used on motor-cars, etc.

(Reference has been directed under Patents Act, 1902, to Specifications No. 4028, A.D. 1881, and No. 7321, A.D. 1891.)

- 27,379. WORKMEN'S TIME-RECORDERS. J. LEA, Middlesex. Dec. 1.

Workmen's time-recorders are provided with a cylinder 1 carrying one or more record sheets and rotated by a clock-driven shaft 2, on which it is capable of sliding. Each record sheet is divided into parts corresponding to days of the week, and

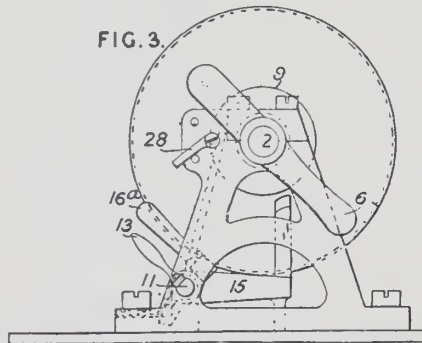
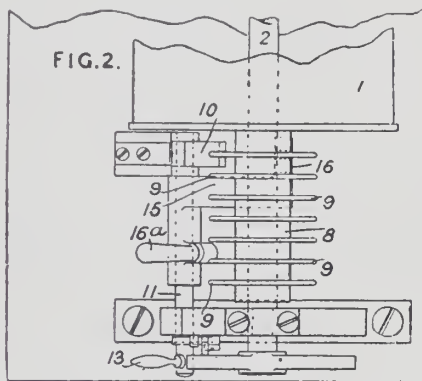

the cylinder is formed with an extension 8 carrying disks equal in number to the divisions of the sheet. Secured to an axle 11 is a spring-controlled fork 10 adapted to engage with one of the disks. Loosely mounted on the shaft 11 is an arm 15 carrying a second fork 16, which may engage with one of the disks when raised by a handle 16a. To bring the time sheets into position for a new series of records, the arm 15 is moved along the shaft 11 and raised to engage the disk next to that held by the fork 10. The shaft 11 is then rocked by a handle 13 to disengage the fork 10, the arm 16a is returned to its original position carrying the cylinder with it, the fork 10 is released to engage

the disks, and the fork 16 is allowed to fall free. A marking-device is provided for each employe, and is operated on pressing in a rod 20 carried by the casing; it may consist of a container 19, Fig. 4, screwed to the rod 20 and filled with ink from a

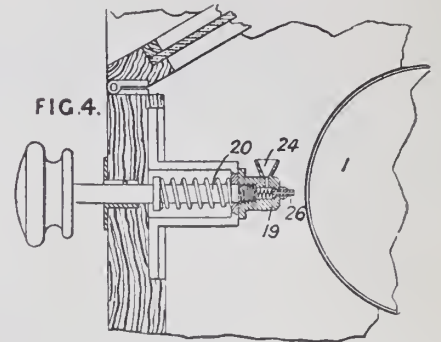

reservoir 24. Moving in the container is a spring-controlled tube or rod 26 which is depressed on striking the paper, thus making a mark thereon. Ink may be dispensed with and the rod may be arranged to perforate the paper, or an ink ribbon may be employed. The shaft 2 is provided with a handle 6, Fig. 3, for winding up the clockwork, which may be electro-magnetically controlled, and a stop 28 is employed to limit its return movement.

Complete specifications accepted March 18, 1908.

- 8,402. WATCH. PENDEBURY.
 - 15,649. BRACELET. DOPPENSCHMITT.
 - 19,508. BUCKLE. LUHMANN.
 - 23,790. MATCH-BOX. HAUPT & SCHNELLFUERZEUG-FABRIK "BLITZ" GES.
 - 24,624. STUD. HEMMING.
 - 26,183. OPTICAL ANGLE-MEASURING INSTRUMENT. OPTISCHE ANTSALT C. P. GOERZ, AKT-GES.
 - 26,464. SCARF-PIN RETAINER. BLACKBURN.
- Applications filed March 9 to March 14, 1908.
- 5,410. BELT-BUCKLE. CONRAD WITTMANN, Liverpool. Complete specification.
 - 5,451. SILVER-LIKE ALLOY. EDUARDO BARAIA, Birmingham. Complete specification.
 - 5,452. MATCH-BOX. EDWIN FULLER, Basingstoke.
 - 5,462. SLEEVE-LINKS. STANLEY JOHNSTONE, London.
 - 5,577. INKSTAND. OTTO TRINKS, London.
 - 5,580. BRACELET. SIEGFRIED SIMON, London.
 - 5,609. DEVICE FOR INSERTING COLLAR-BUTTONS. ERNST ADLER, London. Complete specification.
 - 5,652. ALARM CLOCK. RUDOLF METZ, London. Complete specification.
 - 5,663. REPEATING ALARM CLOCK. P. A. NEWTON, London. Complete specification.
 - 5,675. HAIR-CURLER. LOESCH & BREIDENBACH, London.
 - 5,740. CHATELAINE BROOCH. J. S. WITHERS, London. Complete specification.
 - 5,770. UMBRELLA. ADOLF FRIEDLANDER, London. Complete specification.
 - 5,773. HOSE SUPPORTER CLASP. THEODORE MCKENNA, London. Complete specification.

The South Bend Watch Co., South Bend, Ind., recently received a letter from D. T. Mervine, the superintendent of the Wells, Fargo Express Co., stating that the express company's train leaving Kansas City March 28 was robbed, but that the company had recovered a quantity of the sealed packages of jewelry, etc., from the thief. Among these were shipments from the South Bend Watch Co. to B. F. Jackson, Caldwell, Tex.; Stone & Hitchcock, Caldwell, Tex., and O. R. Broomkant, Brenham, Tex. The express company asked the watch company to supply invoices of the contents of these packages.

Waltham Watches

The history of the WALTHAM WATCH COMPANY is the history of watch manufacturing in America. More than half a century ago this Company introduced a new principle in the construction of watch movements, and has ever since applied the most advanced methods, producing always the best watches in the world. The WALTHAM WATCH COMPANY has built within its own walls the marvelous machinery employed in making the 15,000,000 Waltham watch movements now in use

Waltham Watch Company

WALTHAM, MASS.

THE HOROLOGICAL REVIEW

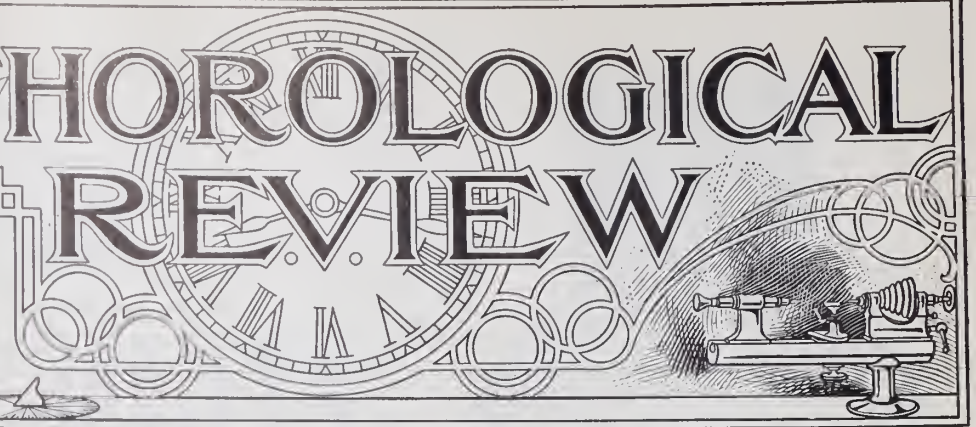

A CATECHISM OF THE LEVER ESCAPEMENT

Being an Informative and Instructive Series of Questions and Answers for Watchmakers and Apprentices.

(Written expressly for THE JEWELERS' CIRCULAR-WEEKLY by T. J. WILKINSON.)

(Continued from issue of April 1.)

QUESTION:—Explain a method by which we can estimate the depthing of the roller jewel in the notch of the lever.

ANSWER:—A preparatory examination



FIG. 42.

should be made of the teeth and pallet lockings; having made such an examination and found the lockings normally correct, we place under the lever bar a wedge of pith or loosely rolled tissue paper, thereby causing the lever to move stiffly, then insert the balance in position and with a finger rotate



FIG. 43.

the balance, thus bringing the roller jewel into the notch of the lever and causing the tooth and pallet to unlock; then continue rotating the balance, thereby bringing the roller jewel out on the opposite side of the notch. Note the appearance of the lever.

It should be found away from its banking, and the tooth will be found on the pallet's locking face in the manner shown in Fig. 42. A like examination should be made of the opposite tooth and pallet lock and a similar condition should be found to exist as shown in Fig. 42.

QUESTION:—If with the lever wedged we found each tooth remained in contact after the manner illustrated in Fig. 42, what opinion would we form about the roller jewel's depthing in the notch of the lever?



FIG. 44.

ANSWER:—Having found the pallet and tooth locking as light as consistent with safety and our test having shown conditions on each pallet similar to Fig. 42, we may pronounce the depthing of the roller jewel in the notch as being correct and in accordance with the pallet's action.

QUESTION:—When making this test what should be done with the guard pin?

ANSWER:—It should be bent away from the edge of the roller table.

QUESTION:—Having completed this roller jewel depthing test, how can we readjust the guard pin to a proper position without guess work?

ANSWER:—To obtain the correct adjustment of any guard pin in its relation to the roller table proceed as follows: Remove the balance and adjust the banking screws so that the drop or first lock only exists. The escapement is now adjusted for primary lock only. Next straighten up the guard pin to what we think is about its

correct position. This done, replace the balance. If the guard pin is in its correct position the watch will start running, going freely without any bind; too much freedom must not exist between the guard pin and the edge of roller table when the bankings are set for drop lock; again, there must be no chance for a bind.

QUESTION:—Why is it the guard pin in some watches will not stand as close an adjustment (bankings being set for drop lock only) in some watches as it will in others?

ANSWER:—Pivots working in holes that

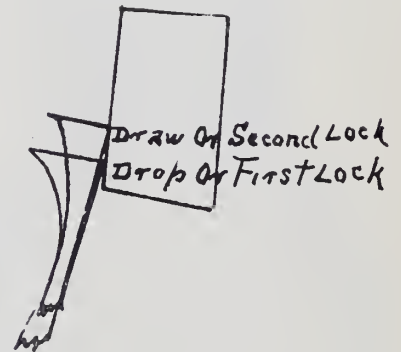

FIG. 45.

are too large for them cause this; also an escapement with defective draw won't stand a guard pin as closely adjusted as a watch in which all parts approach perfection.

QUESTION:—Having adjusted the guard pin, what should we always do next?

ANSWER:—We should open each banking pin to allow the draw or second lock to take effect.

QUESTION:—Why should this be done?

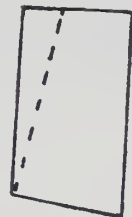

FIG. 46.

ANSWER:—It provides for additional freedom between the guard pin and the edge of roller table.

QUESTION:—Suppose when the lever was wedged a test showed that the tooth and pallet remained in the position shown in Fig. 43; what would this indicate?

ANSWER:—It would indicate as follows:

The G. M. Wheeler Grade

ELGIN WATCH

In 3 Sizes



Popular when it was made only in the 18 size—in great demand now in the thin model 16 and 12 sizes.

Advertised so widely everyone knows of it—priced so reasonably everyone wants it—sells so rapidly every jeweler must have it.

See jobbers list for prices or write the Company.

Send for Elgin art booklets, "Timemakers and Timekeepers" and "The Watch."

ELGIN NATIONAL WATCH COMPANY,

Factories: Elgin, Ill., U. S. A.
General Offices: 131 Wabash Ave., Chicago.
New York Office: 11 John St.
San Francisco Office: 704 Market St.

(a) That the roller jewel was not depthing sufficiently in the notch, or (b) that the lock of pallet and tooth was too great.

QUESTION:—How can we determine whether a or b is the cause?

ANSWER:—If an observation of the tooth and pallet lock show that the locking of tooth and pallet is excessive, correct it, making it normal; this done, we test, and conditions then will be found as shown in Fig. 42.

QUESTION:—If our lever wedged test showed that the tooth was carried off the pallet as Fig. 44 shows, what would this indicate?

ANSWER:—It would indicate that either the roller jewels' action with the fork was too great, or else the lock of tooth on pallet was dangerously light. As before, a personal examination will reveal the condition of the lock. Suppose we find it quite correct, then we are safe in saying that the roller jewel has too much contact with at least one side of the lever notch.

QUESTION:—Is it possible to have the condition illustrated in Fig. 42 on one

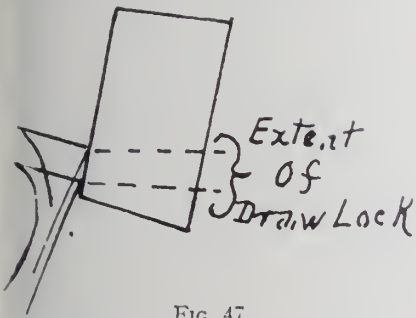

FIG. 47.

pallet and that shown in Fig. 43 or Fig. 44 on the opposite pallet?

ANSWER:—Yes. Such conditions are usually due to ill-set pallet jewels. Correct them before making any alteration in the acting length of the lever notch.

QUESTION:—Define the term "draw."

ANSWER:—"Draw" is the resistance added to the locking face of a pallet jewel which increases the lock by causing the pallet to descend into the escape wheel.

QUESTION:—What is the use of draw?

ANSWER:—It secures the lever against its bank, thereby insuring freedom between the guard pin and the roller table.

QUESTION:—Is there any objections to draw?

ANSWER:—Yes; it adds to the unlocking resistance.

QUESTION:—When a tooth drops on a pallet's locking face we observe a downward motion of the pallet jewel into the wheel which increases the amount of lock. What is this lock termed?

ANSWER:—This second or increase of the lock we have termed draw lock.

QUESTION:—What controls the extent of draw lock?

ANSWER:—It is controlled by the position of the banking pins.

QUESTION:—Should the adjustment of the banking pins be such that both locks are always present?

ANSWER:—Yes; both drop and draw lock must be present. (See Fig. 45.)

QUESTION:—If the amount of draw lock was too great, how would you propose to remedy it?

ANSWER:—By closing the bankings in.

QUESTION:—Can draw be present without draw lock?

ANSWER:—Yes, as we can practically demonstrate by first closing the banking sufficiently to eliminate draw lock; then with a fine screw-driver lift the lever off its banking so as to bring the tooth down to the lowest locking corner of the pallet; release the lever and it will, of its own accord, return to its banking, thus showing that draw is present on that pallet.

QUESTION:—Explain why it is that when a tooth of the escape wheel drops on the locking face of a pallet the lever continues moving until it touches the banking pin, and give the technical term for this motion of the lever.

ANSWER:—The motion of the lever after drop lock takes place is due to the draw on the pallet's locking face. This motion of the lever is termed "run."

QUESTION:—If the run of the lever was excessive, how would you remedy it?

ANSWER:—In the same manner that too much draw lock is corrected; excess of draw lock and too much lever run being identical, the remedy is to close the bankings in.

QUESTION:—Suppose a pallet possessed too much draw; would it be in any way detrimental to the escapement?

ANSWER:—It would. The unlocking resistance would be greater than is necessary.

QUESTION:—What would be the effect if there was no draw or an insufficiency of it?

ANSWER:—We would have more or less friction between the guard pin and edge of roller table.

QUESTION:—Before deciding that an escapement was defective in its draw, what should we first do?

ANSWER:—Thoroughly clean the watch.

QUESTION:—If after cleaning we still find that the draw, say, on the entrance pallet is not sufficient, how can we increase it?

ANSWER:—Usually we are able to give the pallet jewel a greater inclination, after the manner indicated by the dotted line in Fig. 46; this generally effects a cure. Sometimes a change of pallet stones is beneficial.

QUESTION:—Has the term "extent of draw lock" and the term "excessive draw" the same meaning? Explain what each means, and how excessive draw is produced.

ANSWER:—The expression "extent of draw lock" means the amount of second lock, as judged from the position of drop lock up to the resting point of the tooth on the pallet's locking face (Fig. 47), while the term "excessive draw" applies to any excess in the quantity of draw beyond what is just necessary to retain the lever against its bank.

QUESTION:—If we found the banking pins so adjusted that drop or first lock only was present in a watch, would you pronounce such an adjustment correct?

ANSWER:—No; the second or draw lock must always be present.

QUESTION:—If the banking pins were adjusted so that the lever had no run, would you expect to find "draw" present?

ANSWER:—Yes. The effect "draw" is or should be present on the locking face of every pallet jewel, no matter how the banking pins are adjusted.

QUESTION:—If no draw existed under the

following conditions, how would you remedy it? The watch is clean, freshly oiled, no tight pivots. Each pivot works in good fitting holes, bankings open to allow for draw lock, yet as we move the lever and allow a tooth to drop on to a pallet's locking face we find that the tooth remains resting on the pallet exactly at its point of contact. Under such conditions what would you do?

ANSWER:—The angle of the pallet jewel must be changed in the manner indicated by the dotted line (Fig. 46). If this cannot be done the jewel should be changed for one with a greater pitch on the locking face.

QUESTION:—If a watch had but little draw, due to dirt or any other cause, and the edge of the roller table was rough, what would you expect of the watch's performance?

ANSWER:—The guard pin would bind on the edge of the roller table and the watch would stop.

(To be continued.)

An Old-timer Restored.

EMSWORTH, Pa., April 8, 1908.

Editor THE JEWELERS' CIRCULAR-WEEKLY:

I inclose a photo and drawings which will give you a clear idea of an old clock that I have renovated. I have been working with clocks for the past 20 years, and

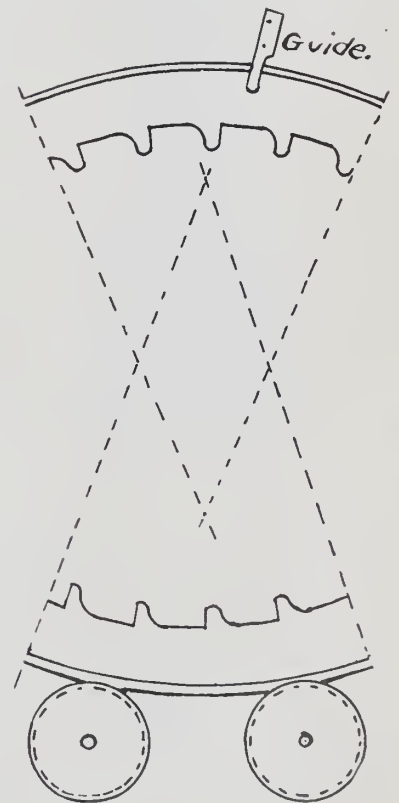

FIG. 1.

have always had a fancy for what I considered a good antique clock.

One day last Summer I had a call from Sewickley, Pa., to come and examine an old clock to see what I could do with it. The condition of the clock as I found it at that time was amusing.

The date wheel had been taken out (because, I presume, some clock man thought

Keystone Solid Gold Watch Cases



“A”



“THE VOGUE”



“C”

- ☐ Flush Joint—made in 12 size Queen only.
- ☐ Illustration “A”—Fair Weight. Antique Pendant, French Bow, Plain Polish only.
- ☐ Illustration “C”—Heavy Weight. Elliptical Pendant, French Bow, Plain Polish, Satin Finish, Roman.
- ☐ This Model is the Thinnest and Most Compact Case made for Standard 12 size American Movements.
- ☐ A Case that will give good satisfaction, meeting the requirements of a popular priced watch.
- ☐ Write your jobber for Samples and Prices.

KEYSTONE 14 K. SOLID GOLD CASES ASSAY

Trade-Mark



in back.

585=THOUSANDTHS FINE

14 K. GOLD ASSAYS 583 $\frac{1}{2}$ -THOUSANDTHS FINE

Note this guarantee



in cap.

Look for



this tag.

THE KEYSTONE WATCH CASE CO.

NEW YORK

CHICAGO

PHILADELPHIA

CINCINNATI

SAN FRANCISCO

interfered with the running), the movement board, you will notice, was cross-rained, and when it broke the movement fell and the pallets cut off two teeth of the scape wheel (Fig. 5a). I made a date wheel for it, put two teeth in the scape

than the scape wheel, I then hammered it to rivet both sides.

Contrary to expectations I found all bearings in good condition, but the scape wheel holes and pallet arbor holes were worn. This necessitated new bushings. I first

the contact of pin with tooth. C shows it after it has moved sufficient for one date. This was repeated for a complete revolution of the wheel.

Fig. 3 shows completed date wheel. Fig. 4 shows hammer spring broken. I sometimes find it necessary, as in this case, to put a thin piece of chamois on the face of spring at point of contact with base of hammer, to avoid unnecessary rebounding.

One of the essential points of reconstruction was the accurate setting of these two new teeth. The method used was as shown

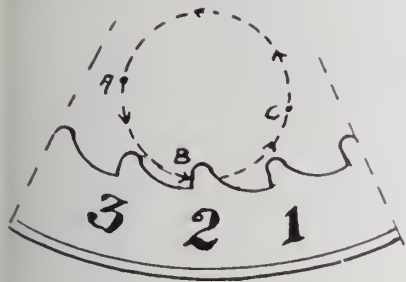

FIG. 2.

wheel and had the missing bronze piece made for the case and dial refinished.

I refinished the case, and although it was slow and tedious piece of work I feel that I have been fully repaid as the original lines and beauty have been fully recovered. I



FIG. 3.

asked the owner if he knew how old the clock was and he said he was certain that it had been in his family for more than 150 years and that his grandfather had referred to it in his diary as being over 100 years old when he got it. That was why I asked



Broken at a.

a.

FIG. 4.

reamed out holes from inside of plates, then inserted hollow bushing tube from the inside and drove it in, letting both ends extend a little beyond the surface of both sides. I next hammered it flush with the plate to harden the bushing so as to make a more lasting surface for bearing, having smoothed the bushing flat with plate on the inside and reamed out the outside for oil.

Fig. 1 shows a view of date wheel held in position by wheels and guide.

Fig. 2 shows a section of the date wheel

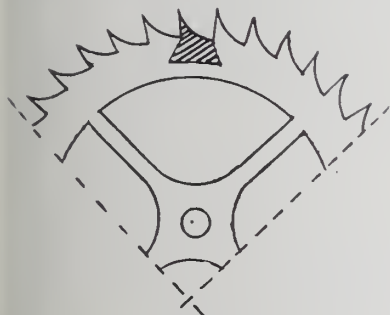

FIG. 5.

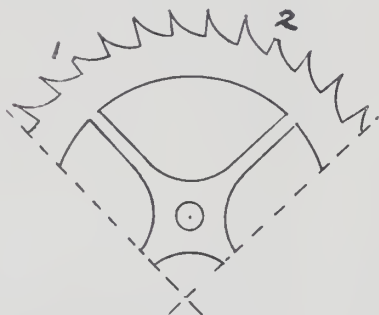
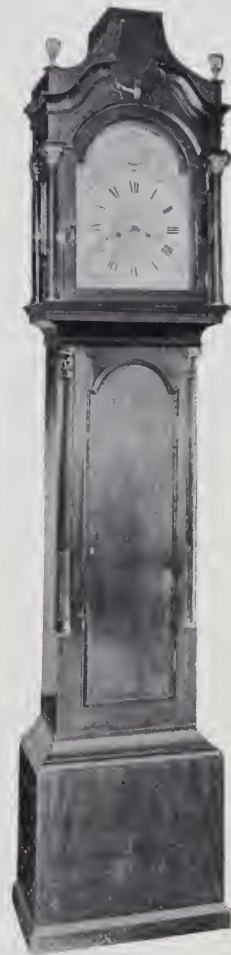

FIG. 5a.

that was missing. I obtained the pitch of the date wheel teeth (see Fig. 2), by revolving time train, with pallets out, allowing pin in date wheel mover to scratch on the side of a plain piece of brass that I cut for the date wheel. This gave me the arcs A, B, C, etc., whose intersections determined the pitch of the teeth. Point A is the entrance of pin in line of tooth, and B is



THE RENOVATED CLOCK.

in Fig. 5. Fig. 5a shows the condition of the scape wheel teeth which pallets cut off when movement fell.

Knowing the value of this clock I spared no time or expense to put it in its original state, and I can truthfully say that considering its age and the condition in which I received it, it has proven a most interesting piece of work from start to finish. It has been running continuously since Aug. 9, 1907.

JOS. G. TAYLOR.

Judge Galbreath has decided that the borough ordinance of Butler, Pa., requiring auctioneers to pay a license fee of \$10 per day unless they had previously been engaged in business in the town for three months, is unconstitutional, because it is in restraint of trade. The fine of \$25 placed on the Japanese under it was released. An appeal from his decision will be entered on the part of the borough.

you if you knew when the maker, William Jourdain, was in business. Your answer in part says: "William Jourdain was apprenticed in 1640 to Robt. Smith."

I first sawed out a piece from the wheel, as shown by the tooth, then cut tooth, as shown, just a little thicker on one side than on the other and drove it lightly in from the side. This piece being a little thicker

IMPORTANT TO HOWARD DEALERS

Every Howard Watch, in both 16-size regular thickness and the new extra-thin model 12-size, is now adjusted to position, temperature and isochronism; and has steel escape wheel and ruby and sapphire jewels.

The Howard factory now produces nothing but *position-adjusted* watches.

Do you realize fully what this means to you, as a dealer — to have a line of high-grade watches made by a factory so trained in every department that it can be confined *exclusively* to position-adjusted goods?

The 17-jewel 16 size grade that has heretofore been adjusted to temperature only is now adjusted also to three positions and isochronism; and every grade that has been adjusted to three positions is now adjusted to five positions and isochronism.

In Railroad Watches we have now three grades, specially designed for railroad service — 16 size, open face, lever setting, double roller, adjusted to five positions, temperature and isochronism.

Write us for new Catalogue and Trade Price-Lists, just issued, March 1st. And give us the name of your jobbers.

E. HOWARD WATCH COMPANY
WALTHAM, MASSACHUSETTS

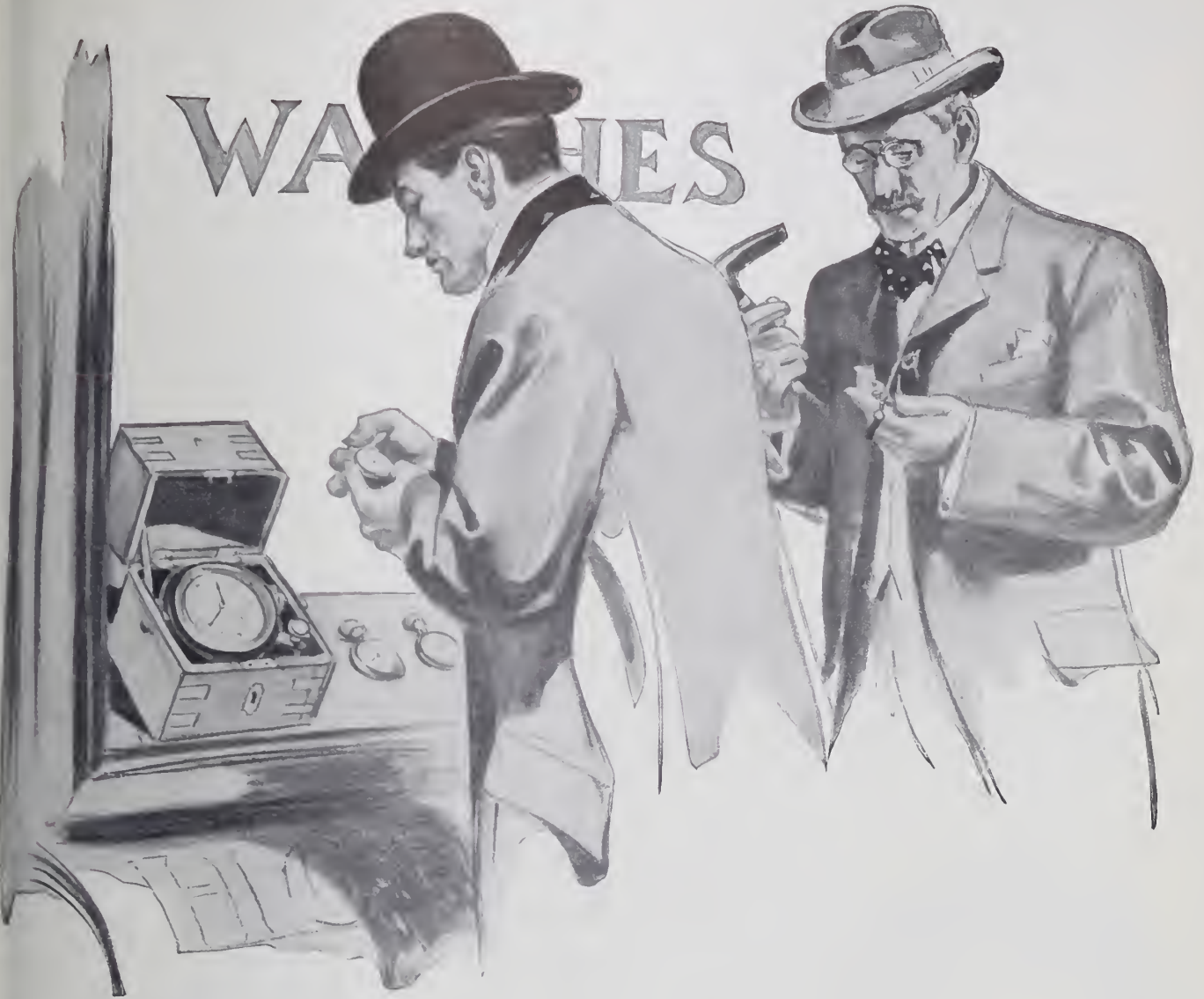

The Howard Watch

There's small satisfaction in always being open to correction on any point. Yet men put up with *near-time* as though there was no such thing as accuracy.

A HOWARD owner may find pleasure in *verifying* the time as he passes the jeweler's window, but he is not the man who stops to "set" his watch. He can face a chronometer without an apology. He walks up to the window with calm assurance—as one meets an equal.

It's the *movement* and *adjustment* that make the HOWARD the finest practical time-piece in the world—not the number of jewels or the amount of gold in the case. It's a matter of science: of workmanship.

The HOWARD was the first American watch, 1842; it has held first place for sixty-six years and has been finer every year.

Not every jeweler can sell you a HOWARD. If you have any difficulty in finding it, write to us for the name of one who can supply you.

The price of each HOWARD watch—from the 17-jewel, 14 K. Gold filled cases (guaranteed for 25 years) at \$35, to the 23-jewel, extra heavy 14 K. Gold cases at \$150—is fixed at the factory, and a printed ticket attached.

Find the right jeweler in your locality ask him to show you a HOWARD—learn why it is more highly regarded than any other watch and why there is distinction in carrying it.

Elbert Hubbard visited the home of the HOWARD Watch and wrote a book about it. If you'd like to read this little journey, drop us a postal card—Dept. D—we'll be glad to send it to you. Also a little catalogue and price-list, with illustrations actual size—of great value to the watch buyer.

E. HOWARD WATCH COMPANY
WALTHAM, MASSACHUSETTS

The above announcement appears in the leading magazines and periodicals for April. It reaches 7,500,000 subscribers (about 30,000,000 readers). It will be seen by every man in your community who can afford to buy a watch. Some of them will be interested. Are you a HOWARD dealer? Do the people of your locality know they can find the HOWARD at your store?

¶ All business is divided into two principles — selling *to* the dealer and selling *through* the dealer. The

New England

“THE WATCH FOR THE GREAT AMERICAN PEOPLE”

is sold not simply *to* you—but *through* you to that *vast majority* demanding a high grade watch who can afford to pay only a *medium price*.

*We build our business
by building yours*

¶ Plans are laid for helping individually, and in a dozen different ways, every dealer in *New England* watches—plans for moving every *New England* he puts in stock.

¶ Write to-day for information.

The New England Watch Co.

WATERBURY, CONN.

Chicago

San Francisco

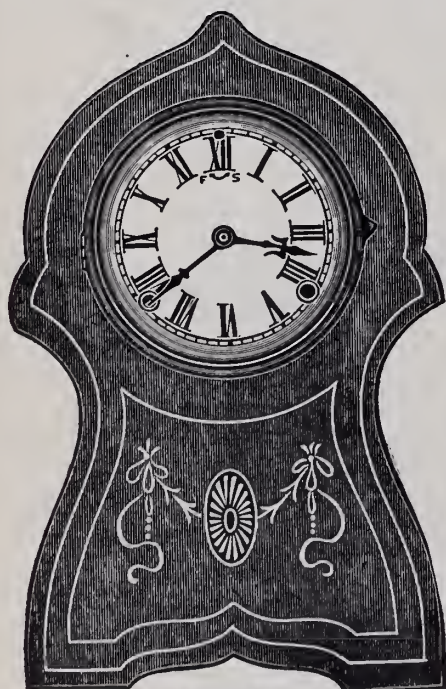

MANCHESTER

Height 13¾ in. Width 8¾ in.

SESSIONS CLOCKS

**Superior Finish
Popular Prices**

We have added a number of fine marqueterie cabinet clocks to our line which will interest you.

**The Sessions Clock
Company**

FORESTVILLE, CONN., U. S. A.

New York Salesroom, 37 Maiden Lane



THE R. & L. OIL

The R. & L. Oil is made especially for those expert watch and clock makers who must have the best and most reliable oil on the market. It does not gum or change, and possesses all the requisites needed for the most delicate mechanisms. Send 25c. to your jobber, asking for R. & L. Oil.

Wholesale Selling Agents

- M. SICKLES & SONS . . . Philadelphia
- SWARTCHILD & CO. Chicago
- NORDMAN BROTHERS CO., . . . San Francisco
- D. C. PERCIVAL & CO. . . . Boston
- CHAS. MAY & SON Boston
- DANIEL PRATT'S SON Boston

53 Franklin Street, Boston
SUSSELD, LORSTON & CO., New York City
H. S. MEISKEY CO. Lancaster Pa.

RANLETT & LOWELL CO.

SOLE MANUFACTURERS
Jewelers' Building BOSTON, MASS

WATCH REPAIRING FOR THE TRADE

Careful, Reliable, Prompt Work. Trade References. Price List on Request.

A. D. PAPAZIEN

71-73 Nassau St., Cockroft Bldg. NEW YORK

Learn Watchmaking

Refined, profitable labor. Competent men always in demand. We teach it thoroughly in as many months as it formerly took years. Does away with tedious apprenticeship. Money earned while studying. Positions secured. Easy terms. Send for catalogue. Address

St. Louis Watchmaking School, St. Louis, Mo.

HOROLOGICAL DEPARTMENT BRADLEY POLYTECHNIC INSTITUTE

Formerly Parsons Horological Institute

PEORIA, ILLINOIS

LARGEST AND BEST WATCH SCHOOL IN AMERICA

We teach Watch Work, Jewelry, Engraving, Clock Work, Optics. Tuition reasonable. Board and rooms near school at moderate rates. Send for Catalog of Information

GUN METAL



WATCHES

Positively the most interesting line of moderate priced Gun Metal, Nickel, Gilt, Enameled, Silver and Gold Watches. GUARANTEED THIN - MODEL WATCHES.

Does Your Stock Move ?

Drop us a line. We will present to you a new proposition to increase your sales. We furnish you the whole outfit free of charge, delivered at your store.

American-Swiss Watch Co.
1 MAIDEN LANE, NEW YORK

HALL CLOCKS



**Elliott's
Celebrated
Tubular
Chimes**

**HARRIS &
HARRINGTON,**
12 BARCLAY ST.,
NEW YORK

Sole Agents to the Trade
for
J. J. ELLIOTT & CO.
LONDON.

Ball Watches

THE RAILROAD STANDARD

The Watch Inspector's Friend

WRITE TO-DAY FOR OUR DEALER'S PROPOSITION

Minneapolis, March 12, 1908.

Gentlemen:
Your 18 size "Official" No. 548110 arrived just in time to aid me with my watch inspection work, as my electric clock was out of commission for 23 days, during which time your watch varied only 4 seconds. Very respectfully,

L. L. WILLIAMSON.

Railway Watch Inspector
1717 E. Franklin Ave.

The Webb C. Ball Watch Co.

Ball Building
Cleveland

Railway Exchange
Chicago

Pacific Type Fast Express Engine for
New York - Boston Service.

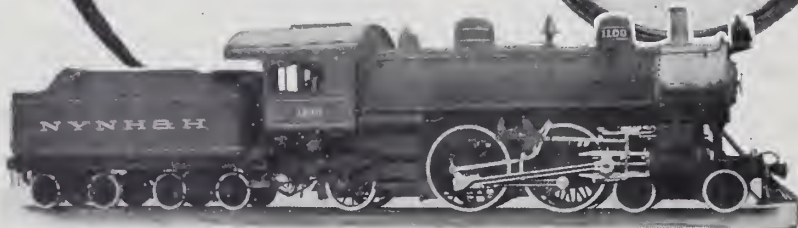

THE progressive jeweler to-day knows that when a customer comes into his store he must be impressed with the idea that he is doing a high-class business.

In order to do this he must have the goods. No article you can buy will give your store more tone than a fine Hall Clock. It will also give you a fine profit. Purchase a "Waltham" and you will soon find a customer for it.

Send for catalogue, descriptive of many styles and kinds.

WALTHAM CLOCK COMPANY

Office and Salesrooms, Waltham, Mass.

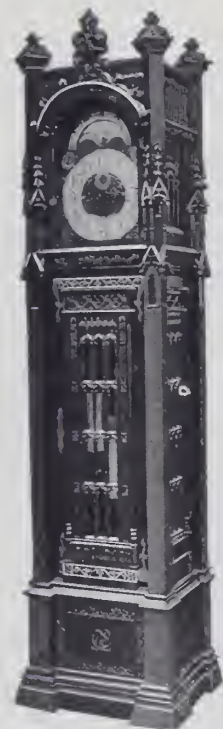

JULES JÜRGENSEN

Watches and Chronometers

PARIS - "THE GRAND PRIX" - 1900

SOLE
RUDOLPH & SNEDEKER
65 Nassau St., New York
AGENTS

Brooch and Case Combined

Cannot Be Lost
Will Not Pull or Wear Off

Dubois Safety Chatelaine Brooch Watch

Patents Pending in U. S. and Foreign Countries.

MERITS—Holds the watch firmly and securely, thus preventing the movement from being jarred, as there is no swinging or bobbing up and down while the wearer is walking or running. Protects both the case and garment from wear.

UTILITY—It can be raised so as to read the time, and reversed to have either the dial or back facing front, without removing brooch pin or watch from the garment. Can be worn on the shoulder, belt, chain or fob.

ARTISTIC AND PRACTICAL—The only brooch and watch combined. Affords absolute security, as it has a safety catch. Nothing to wear out, as it works on friction bearings. Eliminates the possibility of loss of the watch owing to either bow, hook, swivel or link wearing out, breaking or coming apart, as in the old style chatelaine. Does not interfere with either winding or setting of movement.

Licensed under Wachter Patent Ball-Bearing Bow

Dubois Watch Case Co.,

21 and 23 Maiden Lane
NEW YORK CITY



SIDE VIEW OF WATCH.



RAISED VIEW.



BACK OF WATCH.

The Selling of Watches Through Advertising.

The Businesslike Policy of the Great American Watchmakers With Some Examples of Their Advertising.

THE following interesting article on the advertising of the watch companies appeared in the April number of *Profitable Advertising*, and the examples selected by this journal for illustration were reproduced from the advertisements which have appeared in THE CIRCULAR—WEEKLY:

"American inventive genius has made it possible to produce a remarkably accurate

in the trade papers, and patronize them liberally. They realize that the jeweler occupies a unique position, that his advice is solicited and his judgment followed more often than is the case with the average

times, at all times. He knows that a watch that will keep accurate time for a few months would be of little value, and he appreciates that to yield the best results advertising must be kept going all the time. He is not a victim to the egoism of many comparatively small manufacturers, who believe everybody knows them, and it is therefore, unnecessary to advertise. He also has no erroneous impression that a few weeks' advertising will suffice for the rest of his business year. The oldest watch company in America is the most persistent and largest advertiser, and the immense establishment it maintains, the facts that its name is a household word wherever the English lan-



Elgin Watches Know No Season

They are quick sellers all the year round. The demand is steady and constantly increasing. Dealers who carry a full stock of ELGINS are reaping the benefit of our extensive newspaper and magazine advertising.

Is your line complete? The G. M. WHEELER Grade ELGIN "The Watch That's Made for the Majority," meets the great demand for a reliable watch at a popular price, and can now be had in various sizes and stylish thin models for men's and boys' use. See jobbers' list for prices or write the Company. The Elgin Art Booklet, "Timekeepers and Timekeepers," is yours for the asking. Send for it.

ELGIN NATIONAL WATCH COMPANY,
 Factories: Elgin, Ill., U. S. A. New York Office: 11 John St.
 General Office: 171 Washburn Ave., Chicago. San Francisco Office: 704 Market St.

WALTHAM JEWEL SERIES WATCHES

DIAMOND; NICKEL;
 17 diamond and ruby jewels, both balance pivots running on diamonds, raised gold settings, steel escape wheel, exposed sapphire pallets, compensating balance, adjusted, meane-time screws, patent Breguet hairspring, hardened and tempered in form, patent micro-metric regulator, tempered steel safety barrel, gold train, exposed winding wheels.

RIVERSIDE; NICKEL;
 17 fine ruby jewels, raised gold settings, steel escape wheel, exposed sapphire pallets, compensating balance, adjusted, meane-time screws, patent Breguet hairspring, hardened and tempered in form, patent micro-metric regulator, tempered steel safety barrel, gold train, exposed winding wheels.

RUBY; NICKEL;
 15 jewels, raised settings, exposed pallets, compensating balance, meane-time screws, patent Breguet hairspring, hardened and tempered in form, tempered steel safety barrel, exposed winding wheels.

HUNTING OR OPEN FACE

These movements may be obtained in a great variety of Gold Cases from Plain Finished to the most elaborately Engraved, Carved and Enamelled.

Solely Manufactured and Owned by
WALTHAM WATCH COMPANY
 WALTHAM, MASS.

timekeeper for a few dollars and American advertising enterprise has enabled the watch manufacturer to put one of these timepieces in the pocket of practically every American citizen. A luxury in other countries, the watch is considered a necessity in America, and the enormous demand

merchant. A timepiece is not bought for a few months; it is not an article that can be lightly experimented with, and the purchaser must feel assured that the one he buys will keep accurate time for years, for a lifetime perhaps; and the watch manu-

Any Hour in the day, you can depend upon finding a Duober case among these late designs, which will please your customer.
 (L.Y.P. 147)

Hampden movements, from the dainty Four-Hundred series for ladies, to the unparalleled 16 size "Wm. McKinley," are cased at the factory.

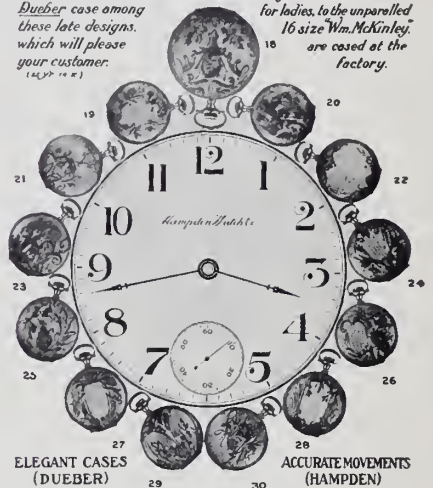

Ball Watches THE RAILROAD STANDARD

Mr. Retailer!

Every Time You Sell a "Ball" Watch.

1. You earn a fair return on your time and capital invested.
2. You secure a satisfied customer (the best advertisement of all).
3. A machine goes into service which will add to your reputation as a reliable watch man.

Write today THE WEBB C. BALL WATCH CO. Ball Building, CLEVELAND Railway Exchange, CHICAGO

The jeweler's stock that does not contain a full line of

New England Watches

is far from being complete, and that jeweler is in time to lose a large number of sales.

The New England Watch Co.
 WATERBURY, CONN.

San Francisco

ENTERPRISING and successful jewelers everywhere are pushing the sale of some individual line of watches which they believe to be superior to all others, and upon which they can also make a satisfactory and justifiable profit.

This explains the growing demand for ILLINOIS WATCHES, in 0, 12, 16 and 18 sizes, by increasing numbers of leading jewelers throughout the United States.

If you are not familiar with the superior quality of—and advantages gained by handling—Illinois Watches, it will mean reputation and dollars for you to investigate.

Every one fully guaranteed.
 Price List sent on application.

ILLINOIS WATCH COMPANY

SPRINGFIELD

Here are some of the publications that are carrying the facts about the HOWARD Watch into the homes of every city and town in the United States.

A wide-awake Retail Jeweler in the Middle West writes the Howard factory, "I believe every man in this town who reads the English language takes one of the magazines containing the Howard advertising."

"I am using this fact for my own benefit, and I have sold more fine watches in the past six months than in any half-year since I started in business. I let everybody know that my store is headquarters for the Howard; that I am 'the Howard dealer' your side, refer to."

It is easy to sell the Howard Watch. It has sixty years' reputation back of it. It is the oldest and yet the most modern watch. It has kept pace with progress. It is the finest watch in America to-day—as it was in 1847.

E. HOWARD WATCH COMPANY
 BOSTON, MASSACHUSETTS.

(three companies alone produce over 2,000,000 movements a year) has been created and maintained by steady, consistent and persistent advertising to the wholesale dealer, the retailer and the consumer. "The watch companies are firm believers

factorer knows that by convincing the retailers of the merits of his movements, by inducing them to recommend his make, he can influence more sales than can be effected by any other means for a like expenditure. So he keeps up a steady, vigorous campaign in the trade press, in season and out of season, in good times, in bad

"The watch companies do not look upon advertising as an expense that can be dispensed with under any circumstances. They consider it a vital factor of their business. They all maintain advertising depart-

(Continued on page 101.)



RETAIL JEWELERS ADVERTISING

**A Few Facts and Figures Demonstrating the Economy
of Judicious Advertising.**

(By FRANKLIN HOBBS in the *Hotel World*.)

I HAVE heard persons say they would not buy advertised goods because they did not care to help pay for the advertising. They wanted full value in the goods themselves. I have heard salesmen argue that their firms did not advertise, and for that reason could sell cheaper.

Some time ago I began an investigation which I have practically completed. I had tests made of various lines of advertised and unadvertised goods, full and complete comparisons made of their respective qualities. I priced goods and bought goods in stores which did not advertise, and in stores which did advertise, and compared prices and qualities. I caused goods to be purchased from merchants who did not advertise, and from those who did advertise liberally, and made careful comparisons of the prices of the goods purchased. Who pays for the advertising?

Advertising is an economy and not an expense—not even an investment. Advertising is a saving. You don't believe that? I didn't expect you to—I didn't believe it myself until I had absolute and convincing proof that the buyer of merchandise does not pay for the advertising. In order to make this matter clear to the lay mind I must use some rather homely examples. A clothing merchant on one corner does not advertise, but he pays \$100 per month rent, employs four clerks at \$75 per month each—pays \$50 per month for his light and \$100 a month for incidental expenses, bookkeeping, etc. On this total expense of \$550 per month, he sells four suits of clothes per day at a gross profit of \$7.50 per suit. This business for 25 business days a month brings in a total gross profit of \$750, and after deducting his expenses of \$550, leaves a margin of \$200 per month as the dealer's remuneration for his personal services, and for interest on his investment.

Another merchant on the next corner pays the same rent, a trifle more for clerk hire, a trifle more for light and a trifle more for general expenses, bookkeeping, etc., and finds that his total expense for the month is \$600—but this merchant spends \$500 a month in advertising. Somebody pays for that. Is it the man who buys the suit of clothes? No. The customer has nothing to do with it, and pays no part of it either directly or indirectly. These two merchants handle the same grades of clothing and sell the same goods at the same price.

At the end of the month the advertising merchant finds that he has sold eight suits of clothes per day—twice as many as the merchant who does not advertise—and making the same profit on each suit, he finds

he has a profit for the month of \$1,500. He deducts his expenses of \$600, his advertising of \$500, and finds he has \$400 left as remuneration for his own services and interest on his investment.

Who paid for the \$500 worth of advertising? Well, in this case the owner of the building paid part of it, because he received no more rent from the advertising merchant who sold eight suits per day than he did from the merchant who did not advertise and sold only four suits per day. That accounts for \$100 of the \$500, which is paid by the landlord; and then the electric light company paid \$45 of it, because the light bill of the non-advertising merchant was \$50 per month, and of the advertising merchant was \$55 per month, instead of being doubled at the same time he doubles his sales. So the electric light company and the landlord paid part of it.

Then the four salesmen paid the other proportion, and were glad to pay it. They had once worked for a non-advertising merchant at \$75 per month, and they are now working for the advertising merchant at an advance of 10 per cent. in salary. They are now getting \$82.50 per month each, and each man sells two suits of clothes per day, while previously they received only \$75 per month and sold an average of one suit per day. So these four salesmen pay \$270 of the advertising bill, and by so doing gain an increase in salary of 10 per cent. And then the bookkeeper and the general expense paid \$85 toward the advertising bill, because the bookkeeper's salary was increased 15 per cent., while the business doubled, so that an economy of \$85 per month was effected. This amount went toward the advertising fund of \$500 per month.

Now, there is a comparison of your advertising merchant and your non-advertising merchant in the same business on the same street, selling the same grade of goods and employing the same grade of help.

Get this point, then, fixed clearly in your mind. Advertising is an economic saving and not an extra expense. In talking with a retail druggist regarding advertising he told me his business was not one that could be profitably advertised, and that he could not afford to advertise. I suggested to this merchant that he spend one-half of the net profits of his business in advertising, and he adopted my suggestion, with the result that his business for 1906 was three and one-half times his business in 1905. His profits were sufficient to pay his expenses, to pay for his advertising, to pay him \$285 per month more than he had been accus-

tomed to draw for himself, sufficient to enable him to increase his stock of goods, as his added sales furnished additional capital, and he is to-day selling every article in his store on which the price is not regulated by the manufacturers or by the Retail Druggists' Association at from five to 15 per cent. less than he was selling or could sell these same articles before he began advertising.

Who pays for his advertising? The answer is the same as in the case of the clothing merchant. The advertising bills are liquidated by the landlord, the light company, the clerks and even by the sprinkling wagon that passes before the front of his store. He paid during 1905 \$1 per month toward the sprinkling of the street in front of his store, and in 1906, although his business was three and one-half times as much, he still pays only \$1 to the street sprinkler. Who pays for his advertising? The sprinkling cart.

Being a manufacturer you say that this does not apply to your business particularly, and fits only the retail business. This applies to the manufacturer and to the jobber and to the retailer, to the mail-order house. The manufacturer has a certain fixed overhead expense, which will not increase more than 10 to 20 per cent. with the doubling of his output. I know factories that are closed at least one to three months each year, the major part of the overhead expenses continuing while no goods are being made.

Advertising will keep these factories open 12 months in the year, would enable the manufacturer to work a night shift in the same building with the same machinery, thus materially decreasing the cost of his product, and enabling him to sell his product more profitably and at a less price. Who pays for the advertising? The man who doesn't—advertise.

Easter Booklets, Etc.

“EASTER Gift Suggestions” is the title of a very attractive booklet which is being distributed by Henry Birks & Sons, Montreal, Que. The booklet measures 3¼ inches wide by 5½ inches high. The cover pages are of a fine quality of blue paper with a conventionalized design woven into the texture. The title is printed in white embossed script lettering. The inside pages are of a cream color, the text being printed in olive green, while the illustrations are printed in black. These half-tones are exceptionally good, being beautifully vignettted and very sharp. The stock illustrated includes veil pins, silver filigree hollow-ware, Wedgewood, Doulton and other fine chinaware, silver deposit ware, leather goods, etc.

The same concern is also sending out cards advertising its facilities for transforming old heirlooms into fashionable jewels. These cards measure 2¾ inches wide by five inches high. They are of a light greyish hue and have the appearance of Irish linen. The printing is done in blue.

Another neat little advertising novelty used in conjunction with newspaper advertising consists of a folder which folds together in accordion style. This folder has really 10 pages, only five being printed

Retail Advertising Department.

When folded up, it measures two inches wide by 5½ inches high. Diamond rings, priced at \$100, \$50 and \$25, are advertised exclusively in this manner. The folder contains three illustrations showing the rings which are sold at the three different prices. The color of the folder is tan. The printing is done in green.

"A Watch of Worth" is the title of still another handsomely printed folder of two leaves, 3¾ x 4¾ in.

Waste in Advertising.

(By J. H. APPLE in the *General Merchants' Review*.)

THERE was expended in advertising last year in the United States alone nearly \$1,000,000,000. So it is estimated. The figures may be high—or low, it matters little which. The important thing is: How much of this was wasted? Nearly all advertising pays. That's the trouble with many merchants. They don't realize that it pays better when better done. Say to them: You're wasting your money, and they will point to an increase in business since they began advertising with no decrease in the ratio of profit. "No waste here." Yes, there is waste.

What you don't get—but pay to get—is waste. If you spend \$1,000 a year in newspaper space—or \$100,000—and don't use it to the best advantage, there is waste. There will always be a certain amount of waste in advertising, just as there will always be a certain amount of waste in handling and distributing merchandise.

To minimize this is the problem. And just in proportion that waste is minimized will advertising pay? The man who attempts to do his own advertising, besides buying the merchandise for the store, selling it, financing the business, running the delivery, and other odd jobs—as is often the case in small stores—wastes his money, unless he is a genius; and geniuses are rare. I know of but one in business, and I am not quite sure of him.

The man who buys the merchandise is too close to the present dollar to do good advertising. He can't see beyond—to future profit. The man who sells the merchandise keeps too tight a grip on his money to advertise well. Too much sticks to his pocket in profits.

The financier of the store has his mind too much on discount and interest to gain the confidence of the people; and the delivery man—well, he ought to know how to manage horses and men, and nothing else.

In a sense an advertiser ought to know advertising—and nothing else. He must rid himself of the thought of present profit; must look at goods through the customer's eyes; be on the side of the customer. In fact, he is the customer's advisor, his attorney, his expert. I sometimes think if a store could have its advertising done by a board of experts—an acknowledged judge of textiles for dress goods, a furniture expert for furniture, and so on—each one giving expert opinions on the value of goods—it would come pretty close to ideal

scientific advertising. And yet it might not be successful, for it would take away that sentiment and interest which comes from a warm conversational pen. It would probably be too cold. Like the bare facts of history, without the touch of humanity. And human interest is one of the essentials of good advertising.

But to return to waste. Keeping an advertisement in a newspaper a week or more at a time is waste. Besides it marks you down as a back number; makes your goods appear old; your methods primitive—none of which may be true.

Only recently I saw an advertisement in an up-the-state journal. "Don't get caught again without your thin clothes as you did last Monday when the thermometer was 90 degrees."

It read all right the first day, Tuesday, for the day before was abnormally hot. But the next week it was still standing—same advertisement—and the Monday of that week was cold—very cold; as cold as an ice box. How much effect do you suppose that advertisement had? It was all waste.

Lying in an advertisement is waste, gross waste. It may bring a little immediate returns, but then comes the reckoning; suckers don't bite twice.

Exaggeration is waste—as much so as lying. And it has a worse effect on advertising in general; just as an ingenious lie is more dangerous than a palpable one.

Perhaps it is not too much to say that exaggeration is the microbe that sooner or later will kill advertising, unless it is destroyed.

It is like the fever of trading stamps. A store gives ten to begin with. Its rival offers twenty. Back comes the first with a bait of thirty—until fifty or a hundred are no more effective than ten. Or like cutting price—each store cuts under the other until there is no profit left at all. Cutting your own business throats—that's what it is!

The Selling of Watches Through Advertising.

(Continued from page 99.)

ments under competent managers. They use the space they buy to the best advantage, sparing no expense in the preparation of copy or illustrations.

"Very few of the watch companies sell to the retailer, the entire product being taken by the jobbers. The most of them never advertise prices, though one or two concern occasionally quote the selling price to the consumer. They have no salesmen. They, therefore, cannot judge the value of their advertising by direct returns, but they know from general results, and from the reports of their missionaries, that their trade paper advertising pays them well. The main object of the advertising of the watch companies is publicity—to keep their names constantly before the trade, and they know that the trade paper that has a large paid circulation, and that is read by its subscribers, will accomplish what they wish to attain."

Wm. G. Clark, Parkersburg, Ia., has purchased the business of the Reinert Drug & Jewelry Co. in New Hartford, Ia.

Psychology in Advertising.

WHAT is perhaps the first practical application of the science of psychology to advertising in text-book form has been made by Walter Dill Scott, Ph.D., director of the Northwestern University of Psychology, whose book, "The Theory of Advertising," is published by Small, Maynard & Co., Boston.

Dr. Scott's book is a most praiseworthy work, and has undoubtedly already demonstrated to practical advertisers the need of a well-grounded knowledge of the theory of advertising. The need of such knowledge is well put in a paragraph by the author of the work himself, who says: "Advertising is a serious thing with the business man of to-day. It is estimated that the business men of the United States are spending \$600,000,000 per year in printed forms of advertising. . . . The enormity of the expense, the keenness of competition and the great liability of failure has awakened the advertising world to the present need of some basis of assurance in its hazardous undertaking. I have attempted to read broadly on the subject of advertising, I have tried to talk with business men, manufacturers, salesmen, publishers, professional advertisers, etc., and in all that I have heard in all of these conversations I have never seen nor heard any reference to anything, except psychology, which could furnish a stable foundation for a theory of advertising."

The present work is really a philosophical analysis of advertising, and purposes to give the prospective advertiser the proper mode of procedure, considering the mental status, etc., of those to whom he wishes to appeal. The most effective manner of securing the attention of the casual reader is well explained in an interesting chapter entitled "Attention."

After clear elucidation and illustration the author deduces certain principles, or they might be called axioms, which he enunciates in terse language. In a chapter entitled "Illusions of Perception," Mr. Scott scientifically shows how our senses may deceive us, and applies all this very appropriately in explaining the relative value of the different forms of advertising make-up. This chapter is followed by another no less valuable, entitled "Illusions of Apperception."

"The Application of Mental Imagery" sounds big to the uninitiated psychologist, but is simply an attempt to show how certain advertisements should actually savor of the thing advertised, or, at any rate, create the desire to possess that thing by suggesting some of its pleasing attributes.

R. F. N.

To guy visitors or give short, sharp flip-pant answers even to stupid or impudent people is a great mistake. Meet rudeness by unflinching patience and politeness and see how much better you feel.

Don't throw waste paper and refuse on the floor—baskets are provided for rubbish. Be very careful never to leave oily waste in rubbish baskets or on the floor—put such in metal cans and see that the cover is on. Spontaneous combustion is a common cause of fire.—*The Book-Keeper*.



STORE KEEPING DEPARTMENT

That this department shall prove mutually beneficial to our readers, it is desirable that the members of the trade generally communicate with THE JEWELERS' CIRCULAR-WEEKLY regarding any advantageous device or plan which they are utilizing in connection with their business.

The Best Arrangement of the Storeroom in Order to Get the Maximum Amount of Daylight.

From the *Illuminating Engineer*.

(Continued from issue of April 8.)

FROM this point of view the desirable show window will be something like that shown in Fig. 1. This figure represents a vertical section through the sidewalk, window and end of salesroom. The floor of the show window is raised, as is usual, from 18 inches to two feet, and the window is completely inclosed to protect the goods from rust, moisture, etc. The back and top of the show window might be made of glass, but the display generally shows up better

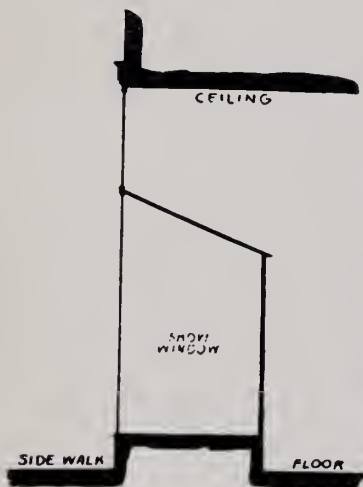

FIG. 1.

from the vertical is drawn as dashes, because it represents only half as much light as the others. These rays from the sky go straight through the glass and nearly all of

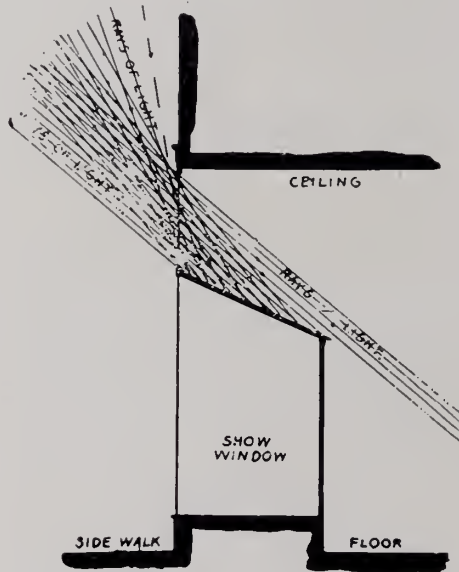

FIG. 2.

them fall upon the top of the show case. The rays which escape the top of the show case fall to the floor at a short distance back from the window.

If the buildings opposite the window were lower, and if the show window top were steeper, more rays would evidently get past and fall to the floor, but the assumed conditions are fairly representative for middle-sized towns. We see that most of the light is lost on the top of the show window. If this top were painted white it would help matters very much. If it is painted a light yellow it will give a warm tinge to the whole interior. But this is not a very efficient way to get the light back into the room, though it may answer the purpose for stores that are very shallow. The reason for the inefficiency is that the paint forms a diffusing surface which, instead of throwing light straight back, throws it off in all directions according to the cosine law. The most of this light then

goes to the ceiling before it finds its way to the working part of the room, and no small part of it is thrown outdoors again.

It is evident that a large mirror might be placed on the top of this show window to considerable advantage. Oddly enough, the writer is not aware that this mirror suggestion has ever been tried. Cheap mirrors when used in a similar way for the reflection of light present to the eye a rather unpleasant appearance, and in this case the mirror is so low that its light would be particularly unpleasant in the eyes of one looking toward the window from the interior of the room. Notwithstanding these objections, it is quite likely that this device would prove fairly satisfactory in many cases.

Frequently one finds a window built similar to the one shown in Fig. 3. The owner

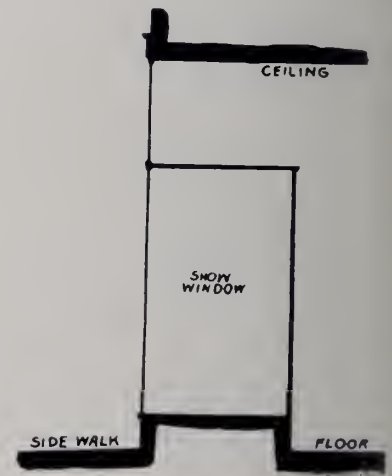

FIG. 3.

with an opaque background specially adapted to it. The top of this show window is generally made of rather dark wood, but a little consideration will show that it may be given a rather light color to good advantage.

Let us assume that the buildings on the opposite side of the street from the window under consideration have a height equal to two-thirds the width of the street, and let us further assume that the upper part of the window—the transom—shown in Fig. 1, is filled with ordinary plate glass. Then the distribution of the daylight coming through the window is something like that shown in Fig. 2, where the lines in different directions represent rays of light, and with one exception, all rays represent the same amount of flux. The line at 10 degrees

has realized the uselessness of the upper part of his window for purposes of exhibit, and hence thoughtlessly has cut it off with a horizontal top. It will be admitted that this form of top is more in harmony with conventional principles of design; mankind has seen so many surfaces meeting at a right angle that we generally prefer to see that angle used unless there is good reason for departing from it. This window top very greatly interferes with the daylight illumination of the room. It not only receives all the direct light itself, but it is so placed that none of the light which it throws off can reach the working part of the salesroom without first going to the ceiling. Furthermore, none of the devices which are still to be mentioned as likely to give greater efficiency will work well with

Storekeeping Department.

this horizontal top. It is to be hoped that the public will sometime become so familiar with a few of these elementary principles of daylight illumination that these blunders will be less frequent and will be seen and appreciated by the ordinary individual.

Window prisms have been on the market and have been largely used for 11 years. They consist of pieces or sheets of perfectly clear glass placed in the window sash in place of the plate glass. On the outer face these sheets or plates are flat, but the inner face is broken up into horizontal ridges with flat faces. These ridges form the prisms, from which the device receives its name and upon which, in a very simple way, its somewhat surprising properties depend. The upper part of Fig. 4 represents a section of a part of a prism plate, while the lower part shows a piece of plain glass.

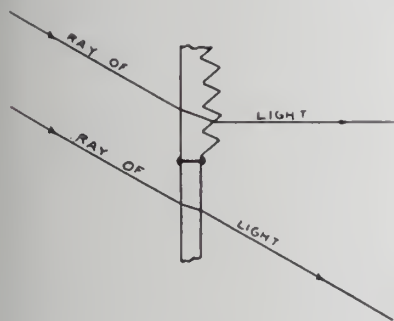

FIG. 4.

The path of a ray of light is shown through each piece of glass. Both rays are initially parallel. As each enters the glass its path is somewhat changed in direction according to the law of refraction. The two rays still remain parallel, the one in the prism and the other in the plain glass. As the rays emerge from their respective pieces we see that they take entirely different directions. Since the second face of the plain glass is parallel to the first one, the law of refraction brings the final direction of the lower ray parallel to its initial direction.

The inner face of the prism, however, makes a large angle with the outer face and, on leaving it, the ray of light, in obedience to the same law of refraction, is bent upward instead of downward. Rays from other directions are all bent more or less upward in a similar fashion, and the net result is that the daylight which comes through such a prism plate is sent further back into the room than that coming from plain glass.

Let us now go back to Fig. 2 and consider the effect of placing window prisms in the transom in place of the clear glass formerly assumed there. The light coming from these prisms, if properly selected, will pass directly back into the lower part of the salesroom. The counter with the goods displayed on it, though it may be half-way back in the store, will receive direct light from the window. This direct light comes without loss, due otherwise to diffusion. In addition to this direct light, the counter back in the store receives diffused light from sidewalks, and this, also, is stronger than in the case of plain glass be-

cause of the stronger direct light falling on the walls.

It should be clear that prisms do not manufacture light in any way; they do not increase the light, they alter its distribution. They reduce the excessive and useless illumination on the top of the show window and increase the illumination of the sales counters.

The inner faces of prisms must be variously inclined to suit the locality in which the prisms are used. If the opposite buildings are low the prisms are less inclined, and *vice versa*. In selecting the prisms for any window one must know the directions from which the light comes to the window, also the directions from the window in which it is desired. This information is



INTERIOR VIEW OF THE STORE OF S. MALTINSKY, BRADDOCK, PA.

generally best given by means of a vertical section through the room, the window and the opposite building.

(To be continued.)

Storekeeping Sense.

THERE is just one way to beat the game of speculation, and that is to invest your surplus instead of gambling with it.

Any method of telling people the advantages of your store is advertising. The method that tells the most people most effectively at the least price is the best advertising.

How much better you like the railroad whose officials are uniformly courteous and obliging without expecting constant tips! Just so the women feel regarding stores.

They say that this is a day of specialists. That may be true and yet the successful merchant is he who sells the most lines well, rather than he who sells one line well.

When a salesman offers you something for nothing, be sure that you know all sides of the proposition before accepting it. There are no gold dollars at half price in the business world.

Advice is a good thing to give only when you cannot avoid giving it, and a good thing to seek only when you absolutely need it. The man who grows tallest is he who earliest learns to depend upon himself.—*Printers' Ink.*

The Retail Jewelry Establishment of S. Maltinsky, Braddock, Pa.

ONE of the attractive retail jewelry stores of Braddock, Pa., is illustrated below. This store is owned by S. Maltinsky and is located at 848 Braddock Ave. The owner conducts a branch store in Wilmerding, Pa., which is larger than the store illustrated on this page.

The Braddock store is 75 feet long and 20 feet wide. The furnishings, wall cases and show cases are all finished in oak. The ceiling is of steel and studded with numerous arc lights. The floor is of black and white tiles. At the right as one enters the establishment is the diamond room. The watchmaker's bench is located in the room

on the left. A large electric clock erected just outside of the establishment adds to the attractiveness of the exterior.

The store in Wilmerding is finished in mahogany, the dimensions being 90 feet in length by 20 feet in width. This establishment also has a steel ceiling and tiled floor. In the new establishment there are 250 electric lights.

Health of Mind and Body.

IF you're not at your best, go and take a cold shower bath or do something to get your blood circulating right and your brain in proper working order. This will pay, even though you "lose" a little time from your business. You'll be more civil to your employes, and they'll work harder and better in your interests.

If you're not in condition to put your best thoughts into your correspondence, wait until you are. Better to "waste" an hour or two, or a day, than to write anything that will do real harm, or that will lose orders for you. You can't make the most out of your business unless you have the maximum of health and all that goes with it.

Cultivate cheerfulness. Do something to drive away the "blues," if you're subject to them. Get into a healthy, optimistic frame of mind. It pays!—*The Mail Order Journal.*

1 2 3 4 5 6 7 8 9 0 1 9 0 8 A B C D E F G H I J K

Alphabet and Figures

FOR CLASS RINGS, EMBLEMS, ETC..

HERPERS BROTHERS,

SETTING MANUFACTURERS,

Newark, N. J.,

1 9 0 8

1 9 0 8 A B C D E F G H ETC. 1 9 0 8

LEIMAN BROS.'

NEW AUTOMATIC, CONTINUOUS-FEED

SAND BLAST \$15.00

May be operated with Foot Bellows or a Pressure Blower

SHORT, STRAIGHT SAND FEED PIPES prevent loss of energy and insure a free flow of sand

EASY TO OPERATE—EASY TO UNDERSTAND

Get our literature about Sand Blast Machines on request

145 Brill St., NEWARK, N. J. **LEIMAN BROS.** 141 Centre St., NEW YORK, N. Y.

Manufacturers of JEWELERS' MACHINERY and BENCHES

JOHN AUSTIN & SON



Assayers, Refiners and Smelters

74 & 76 Clifford Street PROVIDENCE, R. I.

We Do Our Own Smelting.

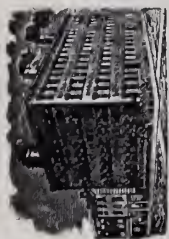

L. LELONG & BRO.

Gold and Silver Refiners, Assayers and Sweep Smelters

S. W. Cor. Halsey and Marshall Sts., NEWARK, N. J.

Prompt attention given to Gold and Silver Bullion.

SMELTING FOR THE TRADE.



HERMAN KOHLBUSCH, Sr.,

ESTABLISHED 1859.

Manufacturer of Fine Balances and Weights for every purpose where accuracy is required.

Office and Salesroom, 194 BROADWAY, NEW YORK.

Send for Price List. Tel. 370 Cortlandt.

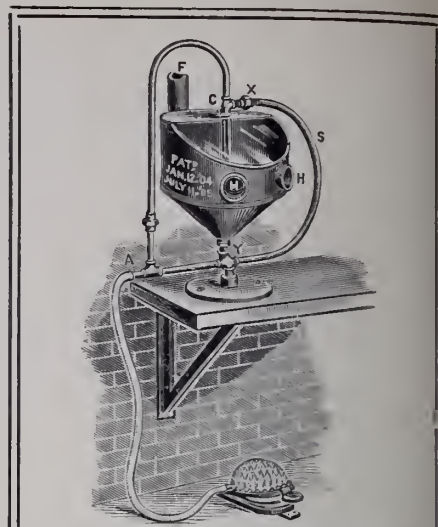
A Small Compound Sand Blast

Price, \$20.00 Foot Bellows, \$6.00

WORKS AS EFFECTIVELY WITH FOOT BELLOWS AS WITH POWER BLOWER : : : :

MADE of Galvanized Sheet Iron, 10 inches diameter, Glass Top, Fittings of Brass and Iron, practically indestructible. Satisfaction guaranteed. Ask your Jobber for it, or write to us. Other Specialties; Zeuner's Best Jewelers' Saws; American Swiss Files, equal to the best imported; Gas Furnaces, for Melting, Annealing, etc., etc.; Positive Pressure Blowers.

E. P. REICHELME & CO.

JEWELERS' TOOLS, FILES AND SUPPLIES

24 JOHN STREET, NEW YORK

Importer and Manufacturer of WATCH MATERIALS, TOOLS, JEWELERS' SUPPLIES AND OPTICAL GOODS



Bargains in Engraving Blocks

Prices on Application.

Fine Gold, Silver and Platinum always on hand. Highest Prices paid for Old Gold and Silver.

A. ZAREMBOWITZ

250 East Houston Street NEW YORK

PLATINUM AMERICAN PLATINUM WORKS

NEW YORK OFFICE 41 Cortlandt Street NEWARK, N. J.



WORKSHOP NOTES AND QUERIES

[Answers are also solicited from our readers to the questions published on this page.]

QUESTION No. 2109.—Silver Rings and Discolored Fingers.—*Can you tell me why silver rings should turn the wearer's fingers green? We sold five silver rings and in every case they discolored the fingers a dark green. Would any grade of silver do this?*

ANSWER:—If the rings were fine silver the only discoloration on the wearer's fingers would be a slight dark hue under the rings. This would be caused by the oxidation of the silver, which rubs off and shows on the finger. But fine silver is very soft, and for that reason is alloyed with copper, producing what is known as sterling silver, which makes it harder and more durable for all purposes. The green that shows on the fingers, as mentioned by you, is no doubt caused by the copper alloyed with the silver, which also indicates that there may be an excess of copper—perhaps more than is usually employed for producing the regular sterling silver. Rings which are claimed to be silver are sometimes made of light-colored brass, then silver plated and polished. They may have been polished hard on the inside in order to give them a good appearance, and the silver may be cut through at the corners or edges, which would cause the finger to become green from the exposed brass. To determine whether or not the ring has a brass base, polish one inside, then note the color on the edges or corners. If different shades are observed, then the ring is silver plated. Silver will always discolor the hands or skin a little, especially in warm weather when there is some perspiration.

QUESTION No. 2110.—Coral Colored Ivory.—*We have some ivory ornaments that we want to stain to match the color of coral. Can you tell us how to do this?*

H. R. & Co.

ANSWER:—The ivory should be laid in nitric acid for a short time, then rinsed in water. Prepare a concentrated solution of carmine in spirits of salammoniac diluted with 1,000 parts of water, and boil the ivory in this until the desired coral color is obtained.

QUESTION No. 2111.—Ivory Inlaid with Silver.—*How can I inlay silver in the engravings on ivory?*

I. I.

ANSWER:—The engravings may be filled with silver by taking nine parts of nitrate of silver to 40 parts of distilled water. Allow the fluid to remain about 30 minutes, then dry off with blotting paper and expose the etched ivory at once to the sunlight.

QUESTION No. 2112.—Crystalline Appearance of Tin.—*I want to make some tool handles out of sheet tin and want to give*

them a crystalline appearance, such as is seen on many fancy articles and trinkets.

C. A.

ANSWER:—To produce the crystalline appearance, use well annealed and heavily tinned plates. Clean them by rinsing in a diluted nitric acid bath and then with water. Make a dip composed of nitric acid, one part; muriatic acid, three parts; water, four parts. Heat to about 180° F. and dip the plates in this for a few moments; take out and after a short exposure rinse in water. This may have to be repeated if the desired crystalline appearance is not effected. When satisfactory, rinse in hot water, dry and lacquer.

Oxidization of Silver Articles by Means of Platinum.

FOR the production of a dark color on silver, the use of platinum is an unsurpassed medium. The facility with which it can be effected is also very much in its favor. If it were not for the question of cost, platinum would be employed almost exclusively for this purpose. This metal is entitled above all others to the preference because the color it produces is actually black, and not gray, and because it is produced in the simplest manner by immersion or by application with the aid of a brush. No electric current is required, because we are not dealing with an electrolytic process. If we have to deal with a few portions we use a small brush, whereas large surfaces are coated by immersion, in the same manner as in oxidization with hepar of sulphur. In addition to this, the platinum black excels every other substance used for oxidization in the permanence of its adhesion. No lacquer or varnish is required; neither alkalis, acids nor other substances can attack the coating, and even warm cyanide solution, which, in the hepar of sulphur, rapidly dissolves the sulphide of silver, is without effect.

A number of manufactories of silver goods still employ hepar of sulphur for oxidation. Many of them would prefer platina inasmuch as it produces a better color and the cost, in the oxidization of goods in large quantities, is not materially greater; as, however, the platinum process is somewhat unknown, it is not so much used. In the treatment with hepar of sulphur, the color of the deposit in itself is not good; moreover, it is not sufficiently resistant to the cleaning and polishing to which the articles are subjected.

Dissolve chloride of platinum in two to three quarts of pure water (rain water or distilled water is the best). When this has

been effected and the solution is clear, one quart of pure alcohol is added (denatured alcohol will not do) so that the solution, when applied to an article, will dry quickly. It may be readily understood that the solution can be made without the addition of alcohol; the drying then requires more time and the oxidization of the articles is unnecessarily prolonged. If too much alcohol is used, the article treated is likely to take fire when heated over a lamp.

The platinum solution is now ready for use; it contains about one per cent. of metallic platinum. If it is made stronger the oxidization will proceed more quickly, but the consumption of platinum is greater. The strength of solution indicated (about one per cent.) will suffice.

The application of the chloride of platina solution follows, and this is effected with the aid of a small brush. The exterior surface of the silver must be free from fat substances, so that it can be evenly covered with chloride of platinum. The workman paints the surface and then heats it over a Bunsen burner, so that it quickly dries. Care must be taken that the article under treatment is not too highly heated. If the color is not dark enough, a second application may be made; as a rule, two or three coatings are required.

The chloride of platinum being applied with a brush, the rear side of articles to be oxidized*—things like forks and spoons—can be left free from platinum and the platinum chloride only applied to the parts where it is required. When we take into consideration the fact that the process requires but little platinum, the cost, when the character of the work is taken into consideration, is not too great.

The above-described method may be cheapened in the following manner: To each 4,500 parts of chloride of platinum solution we add 28 parts of chloride of iron. This dissolves at once in the solution and produces just as black a coating as pure chloride of platinum solution. Copper may also be employed in conjunction with platinum for oxidization, and here we use, to each 4,500 parts of platinum solution, 28 parts of chloride of copper. The mixture is applied in the same manner as pure platinum solution; the color in this case, however, is not quite so dark. It is nevertheless black and is permanently durable.

In oxidizing silver we must not overlook the fact that not all goods are adapted to the process, nor must we forget that oxidization is not such a very easy task; it requires to be understood, and to obtain an artistic effect a skilled workman is necessary. When all these conditions are complied with, however, no process furnishes better results than the one described.

*The expression, "oxidization," is really wrongly employed in this case, the entire proceeding representing a galvanization process. The term however has become so generally adopted that we therefore use it as facilitating a better comprehension of the process.

P. Savolainen & Bro., Virginia, Minn., have moved their stock into new quarters in the Enterprise block.

The Ashby Jewelry Co., Colorado Springs, Colo., has been appointed official watch inspector for the Denver & Rio Grande Railroad in that district.

C. DORFLINGER & SONS

36 MURRAY STREET

NEW YORK



Hand-Made Blanks only.
Cut, engraved and etched
glass. Light, medium
and heavy stemware,
tumblers, etc.



Correspondence Solicited

TRADE MARK

ESTABLISHED
1850

HAND BAGS

We have a very extensive col-
lection in all desirable leathers

C. F. RUMPP & SONS FINE LEATHER WARE

Fifth and Cherry Streets
PHILADELPHIA

New York Salesrooms, 683 and 685 Broadway

Mr. Jeweler:

Do you know that hun-
dreds of your competitors
in all parts of the country
are making a specialty of
Fans? Do you know that
even a small line of Fans,
properly displayed, will
"dress up" the whole ap-
pearance of your stock?
Of course, the Fans them-
selves must be suitable
for jewelers, and must be
bought from one who
thoroughly understands
the requirements of your
trade. There is but one
such house in America—

Louis Steiner

ESTABLISHED 1870

F A N S
and Novelties for
the Jewelry Trade

**520 & 522 Broadway
New York**

Manipulation of Steel in Watch Work.

By JOHN J. BOWMAN.

Price, 60 cents; postpaid. Jewelers' Circular
Pub. Co., 11 John St., New York.



* Wild Rose, * No. 122—14-inch
Ice Cream Tray

Irving Cut Glass Co. Inc.

Manufacturers of

Artistic Cut Glass

HONESDALE, PA.

F. W. REICHENBACHER

New York Representative

No. 25 WEST BROADWAY, Room 43

Owanda Cut Glass Co.

Manufacturers of

Rich Cut Glass

Originators of New Designs

HONESDALE, PENNSYLVANIA

A complete line of our high-grade goods shown at our
New York Office, 68 West Broadway.



No. 1085.
FLORENCE.

WM. BOLLES' SELF-FILLING NON-LEAKABLE FOUNTAIN PENS



SIMPLE—CLEAN—PRACTICAL

We make our own goods—and they have stood five years' test by the largest dealers in the country. Write for Catalogue and Price Lists.
THE WM. BOLLES CO., 1108 JEFFERSON ST., TOLEDO, OHIO

THE CONNOISSEUR

Devoted to Art Pottery, China, Marbles, Bronzes, Cut and Decorated Glass Ware, Bric-à-Brac, Lamps, Art Metal Wares, Fancy Goods and Kindred Lines.

EARLY ENGLISH POTTERY—TYGS.

By Clement W. Coumbe.

ONE of the most interesting phases in the romantic history of ceramics, though one of the least mentioned, is to be found in the early period of Staffordshire ware prior to Wedgwood's time. So little is known of this epoch and its products outside of the circle of the deeply versed ceramic enthusiasts that one might suppose

being, now an improved imitation of former work, now a degradation of a former style.

On the continent of America, perhaps, we find, in the Indian pottery, true originality and some claim to artistic achievement in the crude. In the early Staffordshire ware, however, we are brought face to face with a style, or styles, so distinctive

that most must confess ignorance of the very vessels themselves known as tygs, piggins, etc.

Is further excuse necessary for initiating THE CIRCULAR-WEEKLY'S readers into the features of this interesting if grotesque and crude ware. Numerous specimens must be existing in this country stowed away among the belongings of families emigrated from Staffordshire and Derbyshire. Both tygs and posset-pots have been turned out from those sections up to the present day, and the posset-pots, being used only for a yearly celebration, are always retained as heirlooms



FIG. 1.—TYG WITH THREE HANDLES.



FIG. 2.—WROTHAM TYG.

the popular ignorance to be through lack of interesting features.

A slight delving into and examination of the subject of the early Staffordshire potters and their wares, however, opens up a chapter full of charm. Look where we will throughout the recorded history of fictile work, it is an evident and more or less traceable *evolution*. Originating in China, Persia, India, Egypt or wherever the aboriginal art of the potter may be claimed to have risen, all the proofs of history positively trace the stream of advance or retrogression in more or less directly *derived* lines. All show up the demerit of

as apparently to preclude any suspicion of imitative source; a startling originality, crude but of great "possibilities."

Where, in all that long period—from the Ming dynasties to the present—do we find style, method of manipulating the medium and even new art lines all spontaneously brought to life? Yet in those Staffordshire tygs, posset-pots, piggins, porringers, puzzle-jugs, etc., we have all this and more. How many readers of THE CIRCULAR-WEEKLY ever heard of *cloisonné* pottery? Staffordshire produced it. Where else do we come across this quaint slip decoration? But so little is known of this interesting period

by the families possessing them. The present explanations and descriptions, together with the rough illustrations of a few typical specimens, are designed to arm the retail jeweler with the power of recognizing the ware when he "happens" on a piece or pieces.

Their rough appearance, due to the peculiar conditions under which they were constructed, is likely to cause the average dealer in bric-à-brac who is not acquainted with the history of that period, to pass over such earthenware as worthless and beneath his notice. But a few lines concerning their origin, and the statement that early Staf-

New Rail Plates
Underglaze Enamel Colors

The latest production of the *Royal Doulton* factories. Exquisitely enameled in rich colors.

Sole Agent
W.S. Pitcairn
 44 Murray Street
 New York

Write for Booklet, "Quaint Bits of Royal Doulton"

Model numbers shown: 877, D2799, D2780, D2785, D2787, D2789, D2882.

Trade-Mark. Trade-Mark.

COLMONT
OPERA and FIELD
GLASSES

have been recognized by Opticians who really wanted a good article without paying too high a price.

With Colmont Glasses
You Have a Guarantee

The name STANDS for honesty and uniformity of construction, fairness of price.

For your own advantage, investigate the "COLMONT" line at your jobber's.

SUSSFELD, LORSCH & CO.
 Importers

NEW YORK

PARIS

The "SECURITY" Necklace Clasp

HEAR IT SNAP
 Absolutely Secure and Simple. Cannot Pull Out
LOCKS IN TWO PLACES
 Making it Doubly Secure
The Only Perfect Clasp
 Ask Your Jobber or Write.

PRICES TO THE TRADE:

No. 1.	10-Karat,	- -	\$6.00 doz.
" 1-B.	14 "	- -	7.00 "
" 1.	14 "	- -	7.00 "
" 1-B.	14 "	- -	9.00 "
" 2.	10 "	- -	9.00 "
" 1.	Platinum,	- -	18.00 "
" 1.	Gold Filled,	- -	2.00 "
" 1-B.	" "	- -	2.25 "
" 2	" "	- -	2.50 "
" 1.	Sterling Silver,	- -	2.00 "

The Hoffman Novelty Co.,

"CLINCH"

Safety Catch for Scarf Pins
 Does not mar the pin. Nothing to get out of order. Simple and neat.
 One turn to the right grips like a vise.
..FITS ANY SIZE PIN..

Patent applied for.

PRICES TO THE TRADE
 No. 1 Gold Plated \$1.50 doz.
 No. 2 Roman Gold 2.00 doz.
 No. 2 14k G'd Pl'te 2.25 doz.

No. 1, 25c.

Makers, 79-83 No. Pearl St., ALBANY, N. Y.

New York Tortoise Shell Co.
 13 EAST 30TH STREET,
 Just East of Fifth Ave.
NEW YORK

Manufacturers of Fine
TORTOISE SHELL GOODS
 Repairing given prompt attention.

fordshire ware stands among the connoisseur's most precious pottery, will aid in recognizing their identity as well as appreciating their intrinsic value. For in the art world there is much material highly valued on account of the historical conditions of its creation as well as its rareness, and the uncouth appearance often hides the fact of its worthiness to fill a prominent place in the bric-à-brac cabinet as a gem to be prized.

To explain the purposes of the tyg, it is first necessary to state the conditions that gave rise to the need of such a peculiar vessel.

At the middle of the 17th century, it must be remembered, Staffordshire and the neighboring counties of England were wild wastes of land, inhabitants were few and far apart, the climate was bleak. As a consequence, neighbors were glad to meet, and proof of their "neighborliness" was usually afforded by a convivial bout of longer or shorter session, during which the liquid "good cheer" was of that character which is supposed to "keep out" the cold, damp weather. The equipment of utensils of those Staffordshire folks was not a plentiful one. A few wooden bowls to eat from, still fewer the jugs to drink from. Cups they had none, and glasses were the refined ware of distant city families only. Hence the drinking vessel was "passed around," and had to be built of substantial proportions.

Simon Shaw, in his "History of the Staffordshire Potteries" (1829), says: "At no very distant period it was the custom for the whole of a company to drink out of the same vessel. William Malmesbury says: 'Formerly the vessels were regularly divided; for to prevent quarrels King Edgar commanded the drinking vessels to be made with knobs on the inside at certain distance from each other, and decreed that no person, under a certain penalty, should either himself drink, or compel another to drink, at one draught more than from one of the knobs to another. Book II., p. 31.'"

An interesting fact concerning this method of drinking from "knob to knob" ("hobnobbing") is the following: These knobs in the drinking vessel became known as "pegs," and our present term of "taking one down a peg" originally meant drinking a "peg," or "knob," more than the other man.

But to return to our tygs. Now, this habit of the entire community drinking from one common vessel afforded an opportunity for man's genius to devise a many-handled jug that would permit each participant to find for his lips a new and clean portion of the rim to drink from when he took the vessel from his neighbor. Surely a hygienic precaution worthy our own germ-laden days! And for this sanitary reason we find tygs with as many as eight or more handles.

And now a word as to the method of ornamentation. A glance at the three specimens of tygs presented in the rough outlines on this page afford some notion of the peculiar characteristics of this "slip" decoration. "Slip," as these columns have often stated, is a method of using a semi-liquid or creamy mixture of clay on the surface of the earthen ware body. In the early Staffordshire ware this slimy mixture was poured from a vessel similar to a teapot of

squat body. The spouts ("quills," they were called) were movable so as to substitute from time to time larger or smaller nozzles according to the kind of decoration required. A hole or vent in the top permitted the slip to pass out of the quill, and the stoppage of this vent with the thumb hindered the flow immediately by forbidding further air to enter. And with this crude instrument the potter distributed the slimy clay in ropy strings, or detached blobs, which, in their entirety, represented ornament, lettering or figures, as the engravings display.

As may readily be supposed, the limitations such a system of decoration entailed were strictly restricted, especially in the hands of artisans ignorant of all art education or training. With this knowledge we must confess that these drinking vessels, crude as they are, prove an inborn talent greatly to be admired. "Overloading" of ornament is of rare occurrence. The distribution and "spacing" is so perfect as to call forth praise from the trained connoisseur of this day.

Fig. 1 is typical of the "medallion" decorated ware that was produced quite plenti-



FIG. 3.—SIX-HANDLED TYG BY THOMAS TOFT.

fully for a time. The medallions were for the most part first stamped in moulds and then fastened to the body. The origin of the style, no doubt, is discoverable in the fad existing at that time of presenting medals on all and every occasion, such as birthdays, anniversaries of all descriptions, as well as public festivities of any kind.

Notice the caterpillar handles. How full of originality! Of course, those uneducated potters little dreamed that the braced or barred handle of the Greek *carchesion* pre-empted the right of discovery. (See "Pots and Drinking Vessels of Ancient Greece," p. 127 in THE CIRCULAR-WEEKLY, issue of Oct. 17, 1906.) It is hard to get away from those Grecian artists, with their exhaustive originality. A peculiar coincidence also is the fact that the *carchesion*, like the tyg, was used for convivial bouts.

Fig. 2 represents an example of Wrotham derivation. For at Wrotham, in Kent, certain of these Stafford clay workers set up potteries, but the crude originality of their style betrays their local training as of Staffordshire. This tyg, with its date clearly declared in its slip decoration as 1663, is of brown glaze with decorations of yellow slip. It measures 7¼ inches high, with a diameter of 5¾ inches, and would make a New York "schooner" look diminutive alongside of it. It reposes in the

British Museum, while Fig. 1 is to be found in London's Museum of Practical Geology.

Fig. 3 is another tyg, the handiwork of no less a dignitary than Thomas Toft, the Staffordshire Wedgwood of this crude art period, and a member of a wide range of Tofts, all of deft "potting" abilities. This last Staffordshire tyg shows advance in refinement of its lines, and probably indicates an attempt at imitation of a piece emanating from a higher civilized center than the Burslem clay fields. The more conventional character of the style is gained, however, at a loss of boldness and originality so admirable in much of the early Staffordshire ware. It is, however, strictly typical of a separate type very popular and prolifically produced in that period, and often called Toft ware from the fact of numerous members of the Toft family creating these more delicately speckled pieces. The cut shows a six-handled tyg, and is of brown glaze decorated in black and yellow slip. Thomas Toft's name (in slip blobs on the rim in this piece) is found on many of his productions, as are the names of other Tofts on their respective handiwork.

Most tygs are of common clay and burnt to a dull reddish brown. The glaze was produced with powdered galena (lead ore). In order to darken and enrich the yellow tones of a glaze produced from galena by itself, proportions of iron ore or ochre, or sometimes an ore of manganese, was added. It may be generally taken for granted that iron oxides or manganese enters into the ingredients when the glazed surfaces are considerably darker than the unglazed.

(To be continued.)

A Unique Medal.

A UNIQUE medal is that known as the "Suffragettes V. C." (Victoria Cross), illustrated herewith, which is the badge presented in England to those advocates

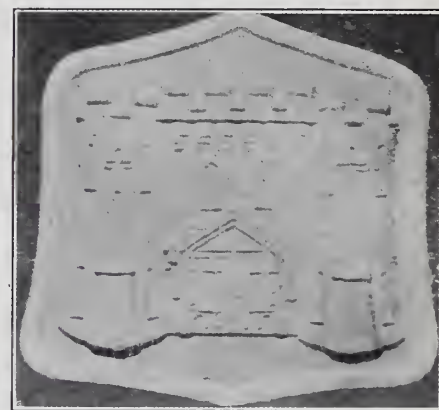

THE SUFFRAGETTES' PRISON MEDAL.

of woman suffrage who have gone to jail by reason of their work in the cause.

The design, it will be seen, is appropriate to the occasion for which it is intended.

Speaking of this, a London contemporary jokingly remarks that it has added to the attractions that prison already presents to the suffragettes of that country. Every woman who has served a term in Holloway has had one of these medals presented to her by her Sisters in the Cause.

A SHEAR

that will cut any kind of design to perfection. Better have a pair—they are mighty useful.

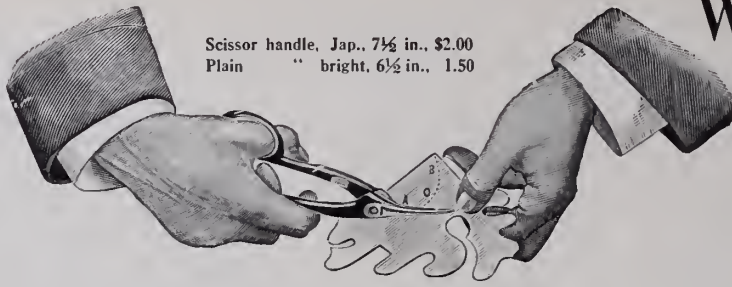

Scissor handle, Jap., 7½ in., \$2.00
Plain " bright, 6½ in., 1.50

William Dixon,

Incorporated

39 John St., New York

Formerly

F. W. GESSWEIN COMPANY



LEMAIRE OPERA GLASSES

LEMAIRE FIELD GLASSES

Best in the World. Used in the Army and Navy.

SUSSFELD, LORSCH & CO., Importers

37 MAIDEN LANE, NEW YORK



All Genuine Glasses
Bear This Mark
Large Variety in All
the Latest Styles



WE BUY

Old Gold and Silver Filings, Polishings, Sweeps, Hand Washings, etc. We will make accurate valuations and hold consignment subject to your acceptance. If valuation is not satisfactory, we reship to you at our expense.

WE PAY FOR OLD GOLD:

22 K. 88c. per dwt.	12 K. 48c. per dwt.
20 K. 80c. " "	10 K. 40c. " "
18 K. 72c. " "	8 K. 32c. " "
16 K. 64c. " "	6 K. 24c. " "
14 K. 56c. " "	4 K. 16c. " "

MARKET RATES FOR SILVER AND PLATINUM.

Try us and you will Appreciate our Squareness, Promptness and Accuracy.

T. B. HAGSTOZ, Ltd., Main Office, 709 Sansom St., Philadelphia, Pa.
SMELTERS, ASSAYERS, REFINERS.

WE SELL

Gold, Silver and Platinum, various qualities, rolled flat or drawn to wire of any gage.

PRICES OF ALLOYED GOLD:

8 K. 42c. per dwt.	14 K. 66c. per dwt.
10 K. 50c. " "	16 K. 74c. " "
12 K. 58c. " "	18 K. 82c. " "

Gold and Silver Solder, either from formulas furnished, or our own. "T. B. H." Alloy, 25c. per oz. Guinea Gold, 75c. per lb. Shot Copper, 40c. per lb. We will send tables for alloying without charge. They save figuring.

'Phone 3759-R.

WM. F. RENZIEHAUSEN CO.

43-47 Oliver Street, NEWARK, N. J.

Gold and Silver Refiners

PROMPT RETURNS MADE FOR ANY MATERIAL CONTAINING PRECIOUS METALS
DEALERS IN GOLD AND SILVER, AND ROLLERS OF STERLING SILVER

Gold and Silver Anodes a Specialty

UNITED STATES SMELTING AND REFINING WORKS

L. & M. WOLLSTEIN

16 JOHN STREET, NEW YORK

SWEEP SMELTERS AND ASSAYERS

Dealers in Gold and Silver Assay Office Bars. HIGHEST and MOST PROMPT RETURNS made for Sweeps and all kinds of Waste containing precious Metals.

HIGHEST PRICES PAID FOR OLD GOLD AND SILVER

Manufacturers of STERLING SILVER.

Importers of PLATINUM.

Orn and Bullion Assays a Specialty.

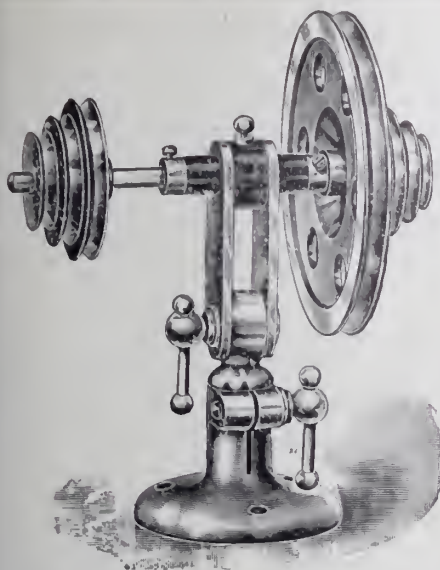

**A New Patent Speed Wheel
Countershaft**

made by G. Boley, all polished and nickel plated, being made with hard bronze bearings which insure perfectly true running, with attachment to hold all wheels for grinding or polishing.



**Robbins' Upright
Roller Remover**

With Improved Revolving Disk and Plunger

Flat bottom, which sets firmly on the bench. You cannot break pivots with this tool, as it is very easily adjusted for any size from jewel series to the largest size. Single or double roller. Nickel-plated. Price, \$2.25.

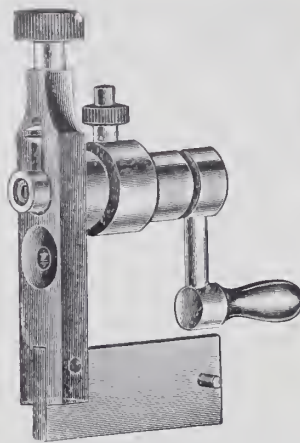

**Robbins' Latest Improved Patent
Mainspring Winder**

Does away with changing of barrels, which alone is a time saver.

Nickel plated, price \$2.00. Directions with each tool.

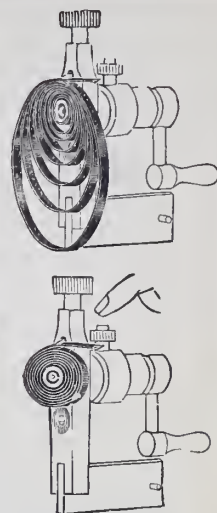

ASK YOUR
JOBBER
FOR SAME

SOLE AGENTS:

77 John Street,
New York City

HENRY ZIMMERN & CO., Inc.

Exclusive Wholesale
Distributors for
U. S. and Canada.



TIME-SAVING equipment and methods that help us get every fractional value out of the filings, waste, sweep and scrap consignments treated by us. We do the work expeditiously and as a rule remit for more than the consignor expects his shipment to yield. Write us.

CONLEY & STRAIGHT
236 Eddy St., Providence, R. I.

**REFINERS
ASSAYERS
SMELTERS**

REFINERS OF GOLD AND SILVER, ASSAYERS AND SWEEP SMELTERS—DEALERS IN FINE GOLD, SILVER AND PLATINUM, ALL KINDS OF GOLD AND SILVER ANODES

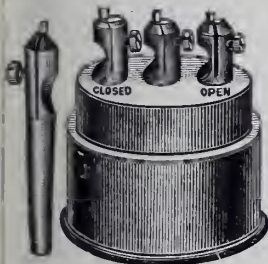

Set of
**3 Jewel
Setting
Cutters**
Price, \$3.00

This set will drill
100 and more
sizes of holes.

Send for Circular

Culman Tools

Are practical—ask the man who owns them if he wants to do without them at any price.

C. CULMAN

Maplewood - - - St. Louis Co., Mo.

Balance Chuck
Price, \$3.50

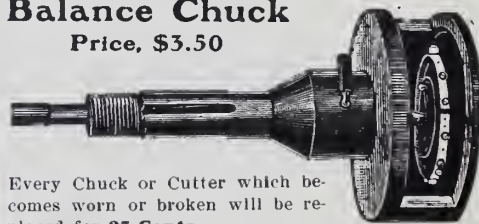

Every Chuck or Cutter which becomes worn or broken will be replaced for 25 Cents.

CASTINGS Gold, Silver, Bronze, Brass, German Silver, Copper and Iron.
L.D. TEL. 2072 L. Supply Jewelers, Silversmiths, Die-makers, Mould-makers, etc. Bronze Forces, Hard Bronze and Iron Shells for Die-cutting Machines. Cast Iron Hub for sinking in Steel Dies. Chandelier, Undercut Work, Statuary.
AUGUST GRIFFOUL 313 HALSEY STREET NEWARK, N. J.

ESTABLISHED
1886

GEO. M. BAKER

TELEPHONE
UNION 1493-R

Gold and Silver Refiner and Sweep Smelter

Office, 91 Page St. }
Works, 77-85 Page St. } **PROVIDENCE, R. I.**

Our processes are strictly up to date and facilities most complete for doing all kinds of refining.
Specialties: Prompt and good returns.

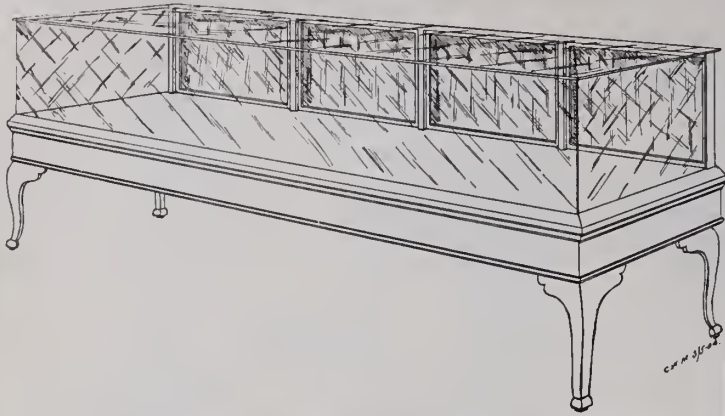

"FOR A QUARTER OF A CENTURY"

We have been manufacturers of

High-Grade Jewelry

Fixtures

Correspond with us before placing your orders

ALEXANDER H. REVELL & CO.

Rees, Dayton, Eastman and Hawthorne Streets, Chicago, Ill.

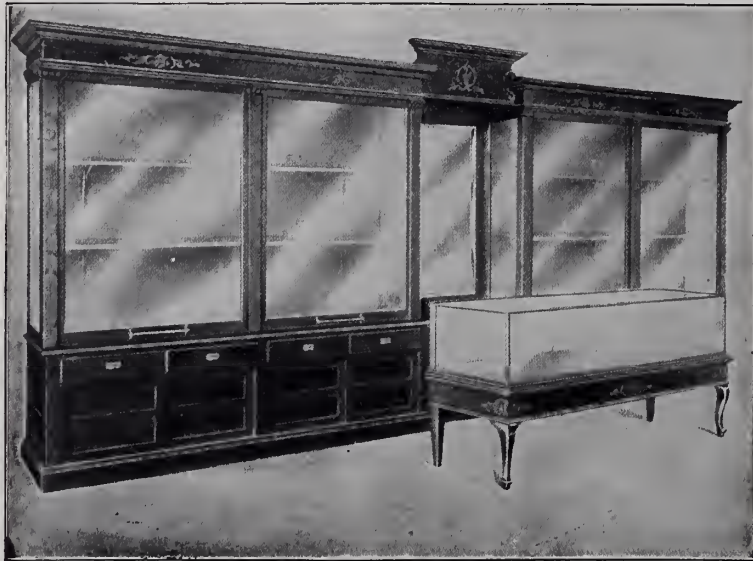

Colonial Wall Case, No. 123. Counter Case and Table, No. 107B.

F. C. JORGESON & CO.

11 to 17 NORTH ANN STREET, CHICAGO

MAKERS OF High-Grade Jewelers' Fixtures

The
St. James

Cor. Walnut and 13th Sts., Phila., Pa.

THE IDEAL HOTEL OF
THE QUAKER CITY

A spacious fire and burglar proof safe has been provided for the convenience of the trade. Palatial rooms with bath \$2.50 per day and up. Rooms without bath, (running water) \$2.00 and up.

EUGENE G. MILLER, Mgr.

JACOT MUSIC BOX CO.

**MIRA MUSIC BOXES
AND MIRAPHONES**

39 UNION SQUARE - NEW YORK.

CRUCIBLES.

Jewelers' Supplies,
Etc.

Established 1850.

J. & H. BERGE,
96 John Street,
NEW YORK.



Established 1879

Manufacturer of

LOUIS W. HRABA Fine Leather Goods

29 East 19th St., New York

Exclusively for the Jewelry Trade



Established 40 Years

Every essential quality of piano construction, tone, touch, scale, design, and beauty of finish are combined in the BRIGGS. They are absolutely and unequivocally a standard piano of the world.

Any **SUCCESSFUL JEWELER** can largely increase his profits by the sale of pianos, and many receive the greatest part of their incomes from selling the

"BRIGGS"

We would like to talk this over with reliable concerns in unoccupied territory.

BRIGGS PIANO CO., Boston

THE JEWELERS' CIRCULAR

WITH WHICH ARE CONSOLIDATED

THE HOROLOGICAL REVIEW.

THE JEWELERS' WEEKLY.

THE JEWELERS REVIEW

Copyright 1908 by
The Jewelers' Circular
Publishing Company.

11 John St., Corner Broadway, New York.

Entered as second-class matter at the New York, N. Y., Post Office.

40th Year

WEDNESDAY, APRIL 22, 1908.

Vol. LVI., No. 12.



Beautiful Casket for Rear Admiral Evans Made at San Diego, Cal.

(See Text on Page 39.)

ALVIN SILVER



BRIDES BOUQUET.

Immediately after Easter there will be an unusual number of weddings.

Silver is always thought of when wedding presents are in demand.

This year there will be many who feel they cannot afford STERLING SILVER flat ware, and if they know of the Alvin PLATED Ware they can give flat ware that will look like Sterling and wear a lifetime.

“The Lily” and “The Brides Bouquet” patterns are of the best silver plated ware made, and in patterns heretofore associated only with Sterling Silver ware.



LILY.

ALVIN MFG. CO

SILVERSMITHS

NEW YORK

“It's the little things in life that count.”

The reason why Fahys Bristol Case is the leading 25-year case, is because when it was first placed on the market our experts had considered every feature, and we embodied more actual gold value in this case than any other 25-year case.

The most artistic designs were selected and have constantly been added to. The finish was the best.



Added to these features it is made with solid gold ball-bearing bow and our patent one-piece pendant, which eliminates all solder. This patent is controlled by us exclusively.

These “little things” are what make Fahys cases superior to other makes.

There is little wonder that every Bristol Case sold ensures a satisfied customer for the retail jeweler. It pays to handle the best in every grade.

JOSEPH FAHYS & CO.

New York

Boston

Chicago

San Francisco

A GENERAL FAVORITE



A general favorite is one whom everybody likes.

Our diamonds are general favorites with those who have seen them.

First, because of the perfection of their cutting, assuring greatest brilliancy, and,

Second, because, we being cutters, there are not two or three profits tacked on to the actual worth of the stones

J. R. WOOD & SONS

DIAMOND CUTTERS

Importers of Emeralds, Rubies and Sapphires

2 Maiden Lane, Corner of 170 Broadway . . . NEW YORK

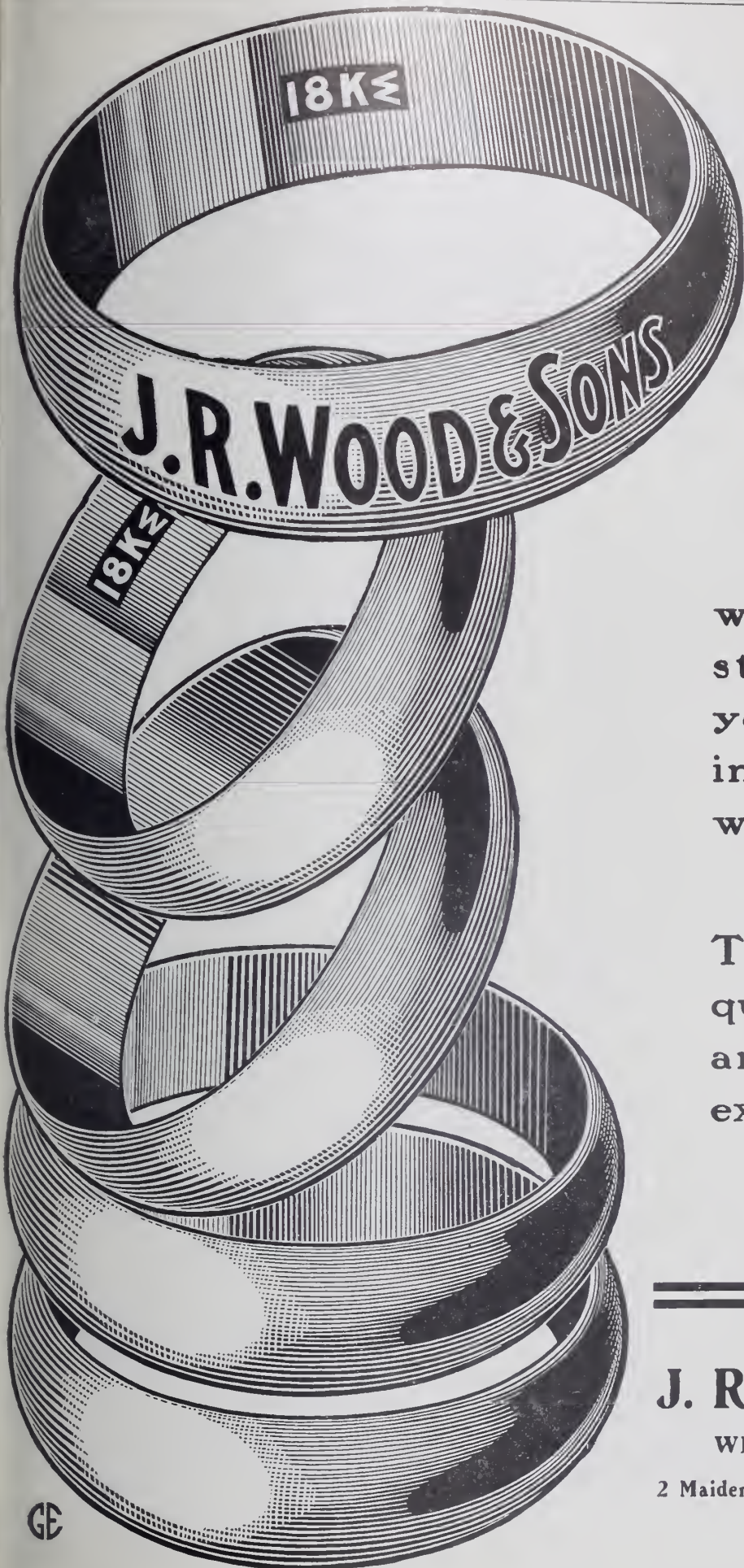

At The Top of the Heap

where they have stayed for **57** years; where we intend them always to remain.

The standard for quality, for finish, and for general excellence.

J. R. WOOD & SONS

WEDDING RING MAKERS

2 Maiden Lane Corner of 170 Broadway

NEW YORK



The Big Dipper

Will Dip Up Profits For You



THE
BEST IN EVERY
GRADE

CHICAGO
701 Heyworth Bldg.

Ask your Jobber

NEW YORK
Maiden Lane

STARWATCH CASE CO.

LUDINGTON, MICHIGAN

COPYRIGHTED BY T. F. KENNEDY



Flat Belcher ring as received with claws badly worn.



How the same ring looks when stone is reset without new claws. Stone is not secure and point is below inside of ring.



How we splice settings and solder in new claws; seams do not show and rings are as perfect as when originally made.

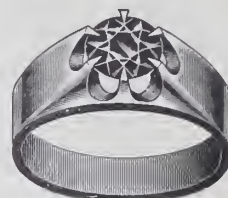

How ring looks with new claws and stone securely reset. Entire ring is finished like new.

When we tell you that we have received as many as 75 diamond rings in one day for new claws and settings, you will not think us extravagant for using a full page in THE JEWELERS' CIRCULAR to exploit this feature of our business, but will wonder if you are getting your share of claw work.

99 out of every 100 owners of diamond rings willingly pay \$1.50 to \$5 for new claws or settings on their rings, but would not buy new mountings for \$5 to \$25.

It is worth while to familiarize yourself and your employees with this work, as it is one of the important little things that helps to make your business profitable.

WENDELL & COMPANY

The firm that did much to change the repair end of the Retail Jewelry Business from a source of worry and dissatisfaction to one of pleasure and profit.

103-105 William Street
New York

TWO WONDERFUL SHOPS

57 Washington Street
Chicago

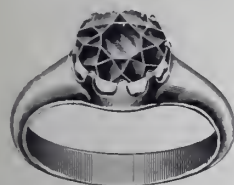

Tiffany ring as received with worn off claws. Stone cannot be reset, as it would be too low to look well and the point would come below the inner circle of ring.
(See cut No. 2 of flat belcher.)

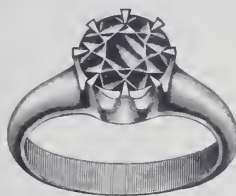

How same ring looks with new claws and stone securely reset. Entire ring is finished like new.

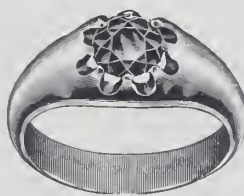

Oval Belcher ring as received with claws badly worn. Stone cannot be reset, as it would be too low to look well and the point would come below the inner circle of ring.
(See cut No. 2 of flat belcher.)

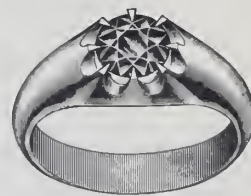

How same ring looks with new claws and stone securely reset. Entire ring is finished like new.

THE PRICES QUOTED ABOVE FOR NEW CLAWS AND SETTINGS ARE SUBJECT TO OUR CATALOGUE DISCOUNT.

WE CAN PUT NEW CLAWS AND SETTINGS ON MOUNTINGS TAKEN IN TRADE AND REFINISH THEM SO THEY WILL BE AS GOOD AS NEW.

WE RETIP CLAWS AND MAKE NEW SETTINGS FOR CLUSTER MOUNTINGS SO THEY ARE AS GOOD AS WHEN ORIGINALLY MADE, AT PRICES THAT MAKE IT ADVANTAGEOUS FOR THE OWNERS TO HAVE THIS WORK DONE.

Carrying no diamonds in stock, entering and tagging each piece of diamond jewelry as received, then giving to each workman but one ring at a time, which is returned before he receives another, prevent any possibility of diamonds being exchanged while in our possession.

Spectacle and Eyeglass Strap Plier No. 105

Price, each, \$1.25

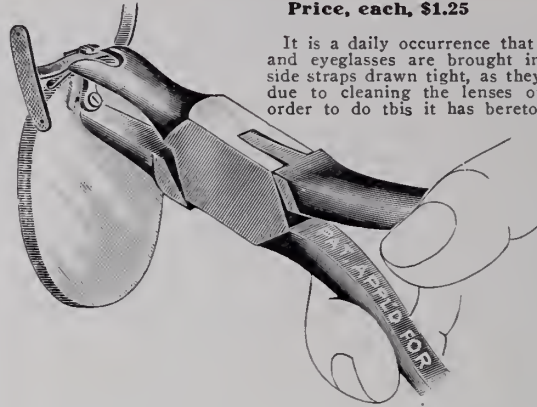

It is a daily occurrence that frameless spectacles and eyeglasses are brought in to have the small side straps drawn tight, as they have become loose, due to cleaning the lenses or other causes. In order to do this it has heretofore been necessary to remove the lenses from the mountings, and as all know, this very often results in breaking or chipping the lenses.

By the means of this plier this can be avoided and the work quickly done.

All that is required is to loosen the screw two or three turns, clamp the frame as shown in the il-

lustration, and bend the straps to the lenses. Retighten the screw, and the work is done.

DO NOT NEGLECT to loosen the screw as otherwise a good job cannot be done, and the lenses are likely to be broken.

Made of best quality Swedish steel, nickel-plated.



EYE GLASS SCREW DRIVER

TO TIGHTEN THAT LITTLE SCREW WHICH ALWAYS WORKS LOOSE

REVERSIBLE BLADE FOR THE POCKET

MAY BE ATTACHED TO KEY RING OR WATCH CHAIN. DESIGNED EXPRESSLY FOR TIGHTENING SCREWS OF EYE GLASSES.

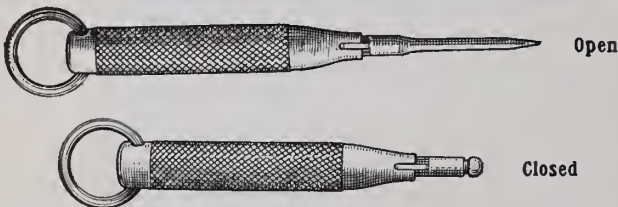

Open

Closed

New Charm Eyeglass Screwdrivers No. 110, Reversible Blades, 15 Screwdrivers on a Display Card. Per Card \$1.75.

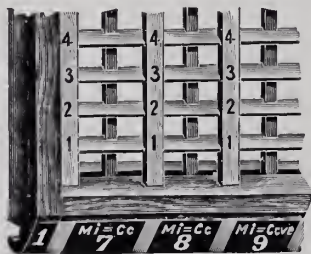

Top View, Showing Skeleton Frame of Drawer. Accumulation of dust and chips is impossible.

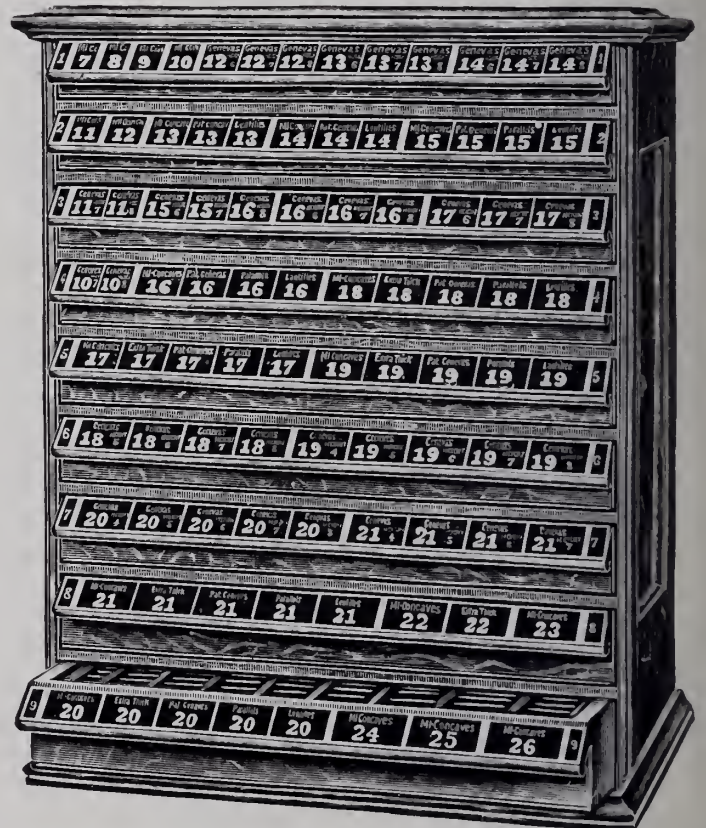

Echarco Watch Glass Cabinet No. 15 (Patented)

Price, each, \$16.00

This cabinet has many new features not found in any other. Novelty and usefulness are the chief arguments in its favor. **CONSTRUCTION AND MATERIAL.**—The cases are made of oak, finely finished and of attractive appearance. Sides are paneled. Partitions of basswood and put together in best manner possible.

PARTITIONS are skeleton, preventing accumulation of dust, chips, etc.

BOTTOMS of cabinets are hollow to receive chips, dust, etc.

ARRANGEMENT FOR GLASSES.—The 9 drawers contain 1,547 spaces to hold glasses in upright position.

Labeling of drawers as shown in cut is on the pulls of the drawers and done in gold bronze on black background.

DIMENSIONS.—24 inches wide, 29½ inches high, 12 inches deep; weight, 45 lbs.; with packing case, 75 lbs.

The construction of drawers, the arrangement of partitions to economize space and weight, and the novel method of showing contents on drawer-pulls are all prominent characteristics and extremely well thought of.

FOR SALE BY ALL JOBBERS IN THE UNITED STATES AND CANADA

HAMMEL, RIGLANDER & CO. 47-49 Maiden Lane New York

THE MAN who doesn't advertise is a good deal like the fellow who throws his sweetheart a kiss in the dark — he knows what he is doing, but no one else does.

We know pretty well what we are doing — we shipped a half million last year — but when you know what we are doing as well as we do, we will ship a million.

We are therefore making our bow through the Jewelers' Circular-Weekly in an endeavor to put you next and let you in on the ground floor.

This is getting to be one of the best advertised and favorably known lines in the business. We intend to keep it up until there is not a jeweler in the country who does not know that the Fleur-de-Lis line is a winner.

THE MINERVA

This bids fair to be an interesting season in adjustable bracelets.



has never yet been equaled, and whatever is doing, you will find us there with the goods.



7801



This trade-mark appears inside the cover of every box containing

MINERVA BRACELETS

Made by THE ELECTRIC CHAIN COMPANY Attleboro, Mass.

Sold only by Fontneau & Cook Co. Sole Sales Agents

THE MINERVA GIRL

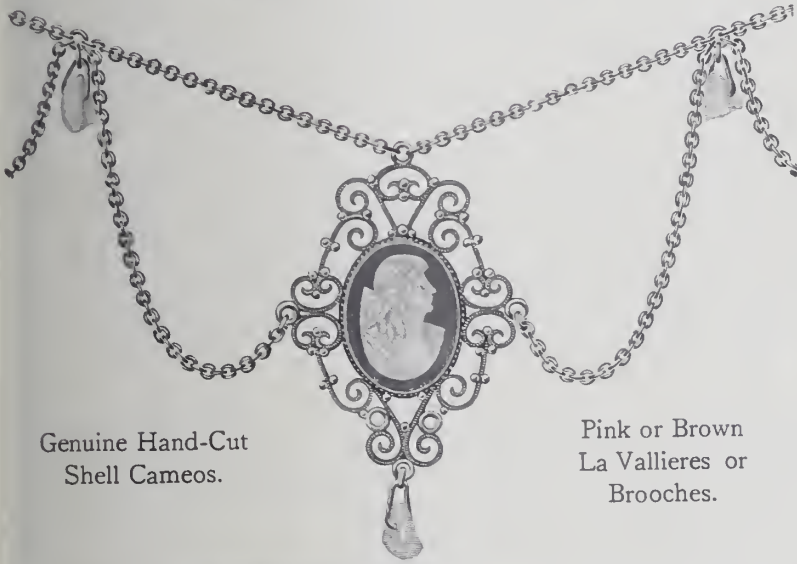

Genuine Hand-Cut Shell Cameos.

Pink or Brown La Vallieres or Brooches.

2699/265C

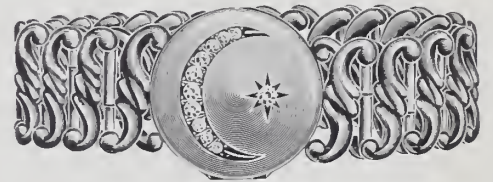

6170—Locket



8114—Polished Genuine Hand Cut Cameos. The Latest Fad.



7977 Polished 7978 Roman 7979 Old English 7980 Rose

We have every kind of an animal that is any good in the jewelry business.



8127—Polished 8128—Roman 8129—Old English 7/8 inch wide.

FONTNEAU & COOK CO.
ATTLEBORO, MASS.

CHICAGO
1203 Heyworth Bldg.

THERE has recently been introduced in Congress a Bill

“Forbidding the importation, exportation or carriage in Interstate Commerce of gold-filled or gold-plated watch cases bearing words or marks importing a guarantee of wear for a specified time and for other purposes.”

THE DUEBER WATCH CASE MANUFACTURING COMPANY is unalterably opposed to the provisions of this Bill, as their enactment will mark a retrogression in the filled case business that will be harmful to the interests of the general jewelry trade.

The Bill is wholly negative, is destructive in its tendencies, and by its terms abolishes every protective feature relating to filled cases that heretofore has safeguarded the interests of the retail jewelers and the public. There is no provision in this Bill to regulate the quality, quantity or thickness of gold used in the manufacture of gold-filled cases; and it prohibits a guarantee of any description whatsoever as to wearing quality

The Dueber Watch Case Manufacturing Company will give its support to have a law passed that will tend to elevate the gold-filled case business; that will protect the trade by regulations that will prohibit the guaranteeing of gold-filled cases that do not contain gold values to justify the guarantees.

It may be left to the imagination of the Retail Jeweler to what level the filled case business can sink if all restrictions are abolished in the manufacture of filled cases, and guarantees as to durability are not permitted, and he may further consider that if this Bill becomes a law, why the next step in the protection of some manufacturers may not be the repudiation of guarantees on filled cases in circulation before this Bill became a law.

Signed { **THE DUEBER WATCH CASE MFG. CO.**
ALBERT M. DUEBER, President



OUR new Buckle and Belt Pin Catalog is now ready and will be sent out in a few days. If you do not receive one, we will gladly send you a copy on request.

We met with such great success with our Buckles that we were encouraged to add from time to time a great many new pieces until we now have as complete and comprehensive a line as any jeweler could desire.

The accompanying illustration suggests one part of the line that we have developed in which is embodied the Egyptian character of ornament.

These Buckles are of heavy weight and no expense has been spared to give them the finest finish possible.

We take this occasion to thank the trade for the support they have given this part of our line in the past and would ask for a continuance of their favors.

R. BLACKINTON & CO.

Established 1861 TRADE  MARK SILVERSMITHS

FACTORY, NORTH ATTLEBORO, MASS.

3 Maiden Lane, New York

WHITING MFG. COMPANY



“AUGSBURG” TEA AND COFFEE SERVICE

The greatest art sale of the 19th century was held at Christie's in London, in June, 1882, when the Hamilton Palace Treasures, collected by Alexander, the 10th Duke, sold for the sum of \$2,000,000.

Among these notable examples were a few choice pieces of antique silverware including the famous Augsburg Cup, for which Baron Rothschild paid over \$16,000; and next in importance was a silver-gilt Tea-kettle also of Augsburg (17th century) manufacture.

It is this Tea-kettle which served as the model for the Whiting Company's Tea and Coffee Service of which an illustration is here given.

BROADWAY AND NINETEENTH STREET

San Francisco, Cal.,
717 Market St.

NEW YORK



COMMUNITY SILVER

FLOWER-DE-LUCE

CLASSIC

AVALON



WHY WAIT for bargain day? Community Silver is a bargain every day, since you get *more than triple plate*, and, therefore, *more than triple wear*, at about the price of ordinary plated ware.

Don't wait. Ask your dealer for Community Silver to-day, and furnish your table beautifully and economically.

More than triple plate

More than triple wear

An enlarged reproduction of a full-page Community Silver advertisement, which will appear during the months of March, April, May and June, 1908, in the leading magazines

Some of the striking and extremely effective Community Silver advertisements, which will appear during the spring months of 1908 in the Ladies' Home Journal, Woman's Home Companion, Minneapolis Housekeeper, Ladies' World, etc.

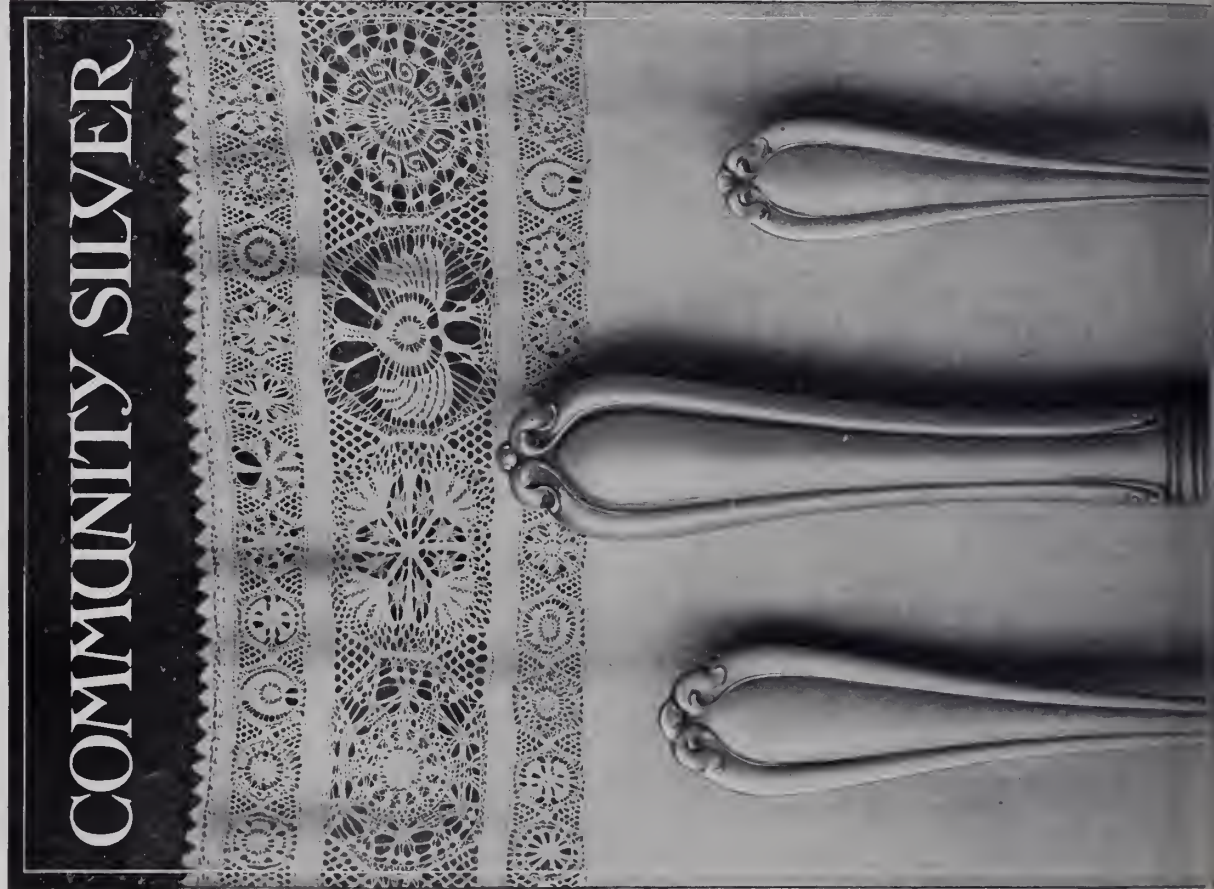
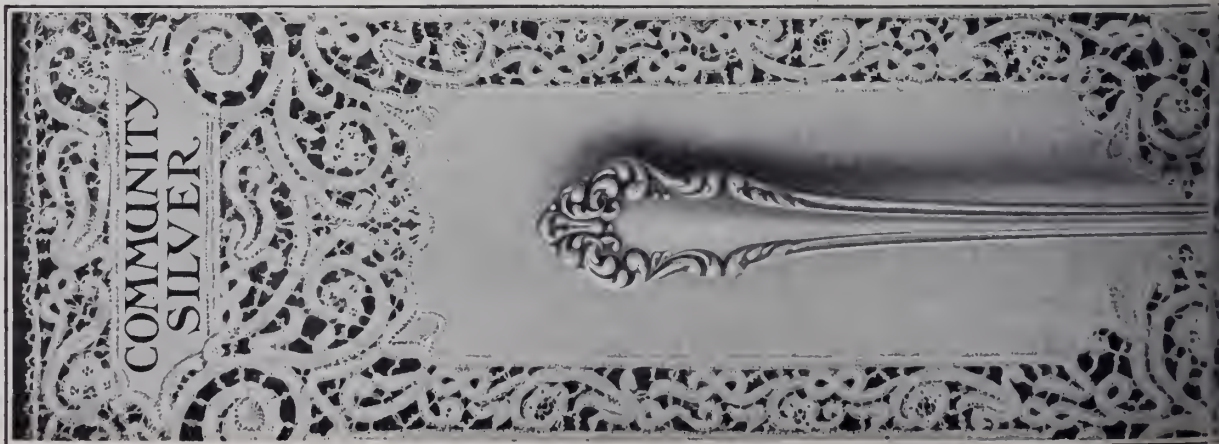

A MILLION WOMEN have shown their confidence in Community Silver by buying it.

Costing very little more than ordinary plated ware, it is so superior in quality and lasts so much longer that every woman can afford it.

Ask your dealer for Community Silver to-day. It will furnish your table beautifully and economically.

More than Triple-Plate
More than Triple Wear

THERE is a delightful social satisfaction in possessing a perfectly appointed table.

Community Silver answers every requirement of the most exacting taste.

Its designs outrival Sterling in distinction, while its low price—about that of ordinary plated ware—brings it within the reach of all.

Ask your dealer for Community Silver to-day, and furnish your table beautifully and economically.

**MORE THAN
TRIPLE PLATE**

**MORE THAN
TRIPLE WEAR**

WHY WAIT for bargain day? Community Silver is a bargain every day, since you get more than triple plate, and, therefore, more than triple wear, at about the price of ordinary plated ware.

Don't wait. Ask your dealer for Community Silver to-day, and furnish your table beautifully and economically.

**More than triple plate
More than triple wear**

It is perhaps of interest to note that the beautiful backgrounds of these advertisements are reproductions from priceless linens at present in the possession of the Art Museum of New York City.



You can add to your Profits
by selling the
Sternau
Collapsible Chafing-Dish

Very convenient and indispensable to campers, excursionists, travelers, tourists, yachtsmen, nurses, automobilists, desiring to prepare hot luncheons easily and quickly.

Made of highly polished Nickel-plate and fitted with Alcohol-burner guaranteed to satisfy.

It is a good seller throughout the spring and summer.

Full particulars on request; also Catalogue 21 illustrating many articles for the jewelry trade.

S. STERNAU & COMPANY

MAKERS OF

New York Showrooms
BROADWAY, COR. PARK PLACE
Opposite Post Office

Coffee-machines, Fancy Teakettles, Chafing-dishes and their Accessories, Smoking Sets, Alcohol-stoves, Coffee and Tea Pots, Candlesticks, Trays, Baking-dishes, etc.

Office and Factory
195 PLYMOUTH STREET
BROOKLYN, N. Y.



2/3 SIZE



The Original **Carmen Adjustable Bracelet**

With 20 years' experience and the best factory equipment that can be procured, we are able to produce

THE BEST IN THE WORLD FOR THE MONEY

The stamp, "The D. F. B. Co.," is a guarantee of quality and up-to-date designs. Ladies' and Gentlemen's Chains, Fobs, Lorgnettes, La Vallieres, Hat Pins, Chatelaine Pins and Bracelets.

THE D. F. BRIGGS COMPANY

ATTLEBORO, MASS.

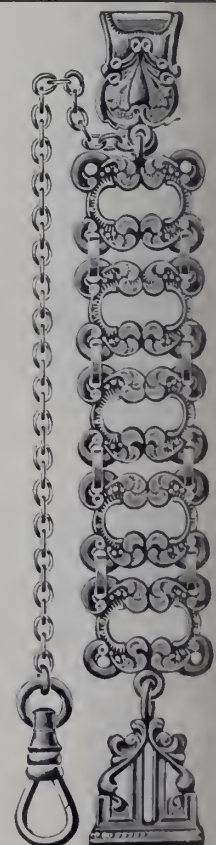

NEW YORK OFFICE
180 Broadway

CHICAGO OFFICE
Heyworth Bldg.

ST. LOUIS OFFICE
Mermod & Jaccard Bldg.

LONDON OFFICE
118-122 Holborn E. C.

The Best Selling "Thread" Pattern in the Trade



The SMITH "PILGRIM"

There never has been a more artistic and lasting design than the Smith "Pilgrim." It is characterized by simple elegance, refinement and dignity of design, and grateful absence of over-ornamentation. The Smith "Pilgrim" pattern will remain permanently in demand. Include "Pilgrim" in your stock. It is without question the best selling "thread" pattern in the trade to-day. Made in all the fancy pieces.

FRANK W. SMITH CO. MANUFACTURERS OF STERLING SILVERWARE Gardner, Mass.



TRADE MARK

SOLD DIRECT TO THE RETAIL TRADE ONLY

FEATURES OF OUR LINE

The UNIQUE, ARTISTIC and UNUSUAL, together with BEST WORKMANSHIP, SUPERIOR QUALITY and PERFECTION IN FINISH



296

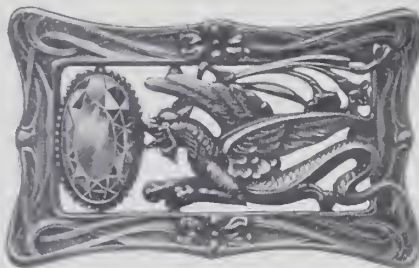

624

SASH BROOCHES
in gold-filled, finished in rose
or dark green (antique).

Sash Brooches

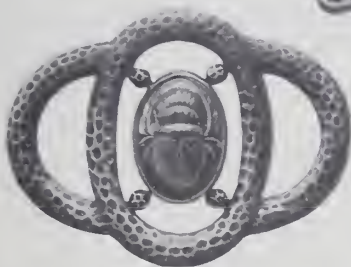

237

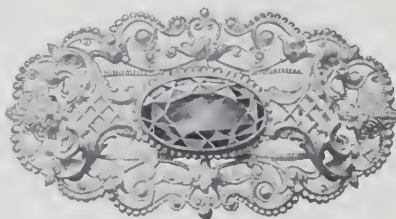

316

We use finest im-
itation stones and
can furnish any
stone or color re-
quired.

We Manufacture in GOLD-FILLED and STERLING SILVER

BROOCHES, HAT PINS, COMBS, HANDY PINS, WAIST PIN SETS, BARRETTES, SCARF PINS, VEIL PINS, LINKS, BUCKLES, SASH BROOCHES, BRACELETS and NECKLACES.

C. RAY RANDALL & CO., North Attleboro, Mass.

NEW YORK OFFICE, No. 7 Maiden Lane

SAN FRANCISCO OFFICE, Henry M. Abrams Co., No. 717 Market Street

Address all orders and communications to Factory, North Attleboro, Mass.

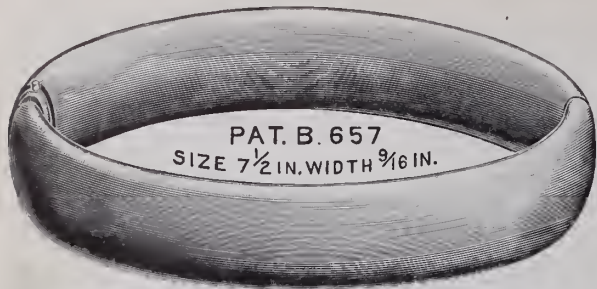

The consumer demands our Bracelets. Our new patterns will suit the most fastidious. Just the Bracelet for the Sweet Girl Graduate.



NEW YORK, 9 Maiden Lane
CHICAGO, 103 State Street

BATES & BACON

ATTLEBORO
MASSACHUSETTS

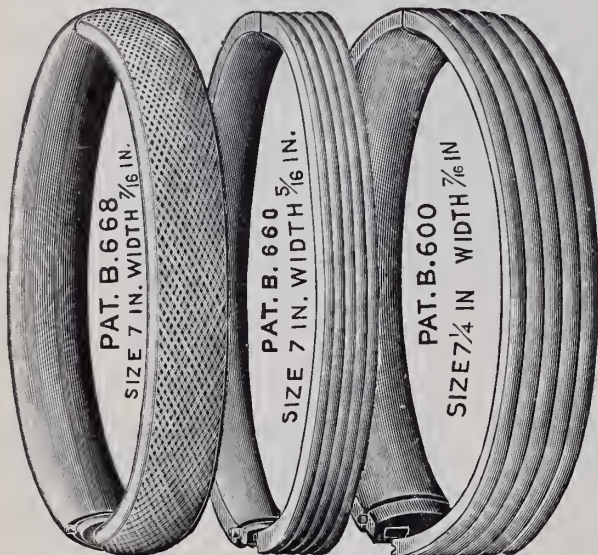

- GENTS' VESTS
- SAFETY FOBS
- DICKENS
- PONY
- NECKLACES
- LORGNETTES
- CHAINS
- BRACELETS
- LOCKETS
- CHATELAINES

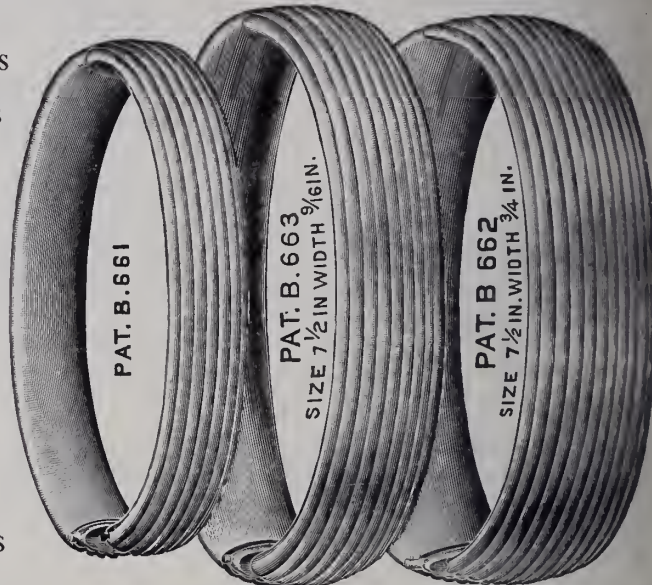

COMPLETE YOUR STOCK WITH RIGHT GOODS

GOLD RINGS

Gold Scarf Pins

Gold Brooches

A Handsome Line of Seamless Wire GOLD FILLED RINGS

All ready for prompt delivery to the Jobber

OSTBY & BARTON CO.
PROVIDENCE, RHODE ISLAND

New York Office
9-13 MAIDEN LANE

Chicago Office
103 STATE STREET



WE show herewith a new style bag—an exceptionally strong, stylish, snappy article.

Our new Spring line is complete—covering the entire range of bags—all shapes, all the different styles of mesh—the largest assortment of frames ever shown. Every piece stamped W. & D., an absolute guarantee of satisfaction.

Your Jobber has them.

WHITING & DAVIS
PLAINVILLE (Norfolk Co.), MASS.

New York Office, 7 Maiden Lane

ENGELSMAN'S PATENTED COMBINATION "GEM" DISPLAY RINGS and ADJUSTABLE STONE HOLDERS MEET A LONG-FELT WANT

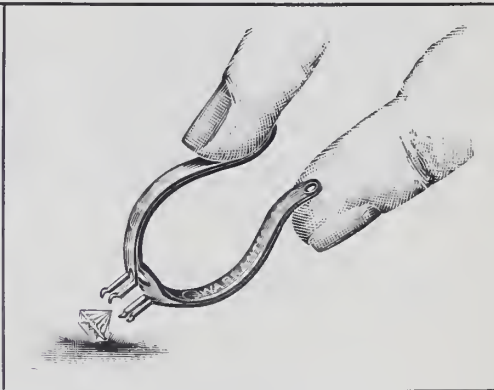
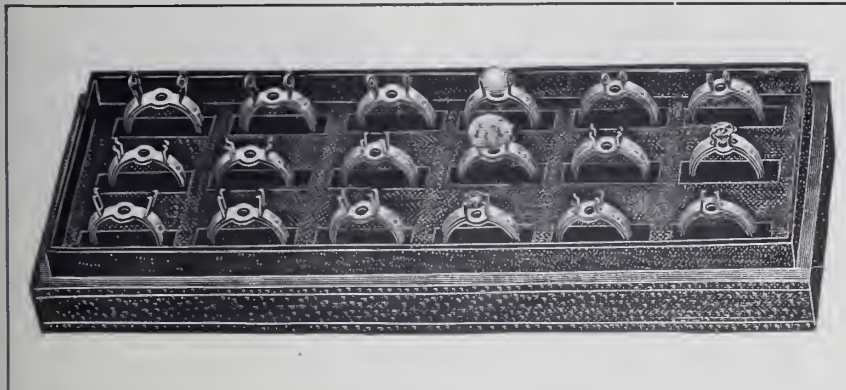

THEY ARE MONEY-MAKERS AND MONEY-SAVERS

UNMOUNTED STONES of any size and shape can be displayed advantageously, as is herein illustrated. Your investment in stock can thereby be *decreased*, as you need not mount them up in expensive settings. Your sales will also *increase* by being able to exhibit unmounted stones. The prices are *low* enough to induce you to buy them and *save* you from incurring frequent losses caused by the awkward handling of the tweezer when your customer desires to examine unmounted stones. Try them. For sale by all jobbers.

Due to greatly improved automatic machinery and reduced cost of production, we are now quoting these as follows:

Sets of 18 (tull set), in box,	\$6.00
" " 12	" " 4.00
" " 9	" " 3.00

HAMMEL, RIGLANDER & CO.
47 Maiden Lane, New York Selling Agents for United States and Canada

毒

"Kotobuki"

毒

(Pronounced Ko-to-bú-ki)

THE JAPANESE WORD FOR LONG LIFE

The Popular Craze in

SCARF PINS

Price in 14 Kt.
\$3.00

MANUFACTURED IN 14 KT. GOLD BY

Price in 14 Kt.
\$3.00

VAN DUSEN & STOKES CO.

MAKERS OF ORIENTAL JEWELRY

IMPORTERS OF CORAL AND SEMI-PRECIOUS STONES

1123 CHESTNUT STREET

- - - - -

PHILADELPHIA

The Perfect Arm Ornament

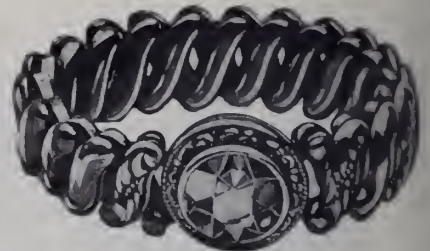
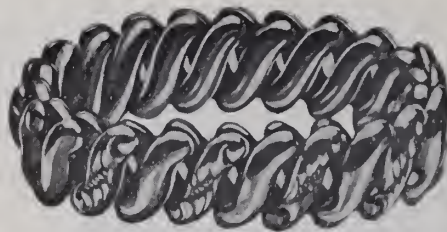

The IMPROVED LADY ETHEL Adjustable Bracelet

While the Lady Ethel Bracelet has been a fast selling article ever since its first appearance, there is no doubt that the improved Lady Ethel Bracelet will sell even more rapidly than the old bracelet. It is made by the same first-class workmen, and from the same high grade stock, but we have made the link a little smaller, which greatly improves the appearance of the bracelet. The Improved Lady Ethel Adjustable Bracelet is the most compact, the strongest and best wearing adjustable bracelet on the market to-day. Try them and see. Samples sent on application.

C. H. EDEN COMPANY Attleboro, Mass.

NEW YORK OFFICE, 550 BROADWAY

Address all communications to the home office at Attleboro, Mass.

...Announcement...



SOLIDARITY.

MR. RETAILER:

We are now ready to deliver through THE JOBBERS a new line of 14k. Gold 12s., O. F. plain bascine THIN MODEL cases, in LIGHT WEIGHT.

The production will be limited

BECAUSE

we cannot AFFORD to manufacture cases at this price under normal trade conditions.

Write for samples on Memo. from your JOBBER. Then TELEGRAPH your order.



SOLIDARITY.

Solidarity Watch Case Company

Established 1885

54 Maiden Lane, New York

General Selling Agents:

JOHN W. SHERWOOD

::

::

FRANK E. HARMER

SOME
TELLING
LINES



FOR
EVERY
JEWELER

THERE'S A CHARM in the unique. This virtue exists to a marked degree in the lines enumerated below. They represent the foremost importations of their class—the unique and unusual. Designs being inspired by the old masters, each piece is a study. Every jeweler should carry examples. Representatives always in the field. See the Lines.

**SASH PINS—VEIL PINS—HAT PINS—BUCKLES—BROOCHES,
NECKLACES—CHAINS—COMBS—JET GOODS**

D. Lisner & Co. *Creating Importers of*
Jewelry Novelties
One-Forty Fifth Avenue, cor. 19th St., NEW YORK



AT all times and under all conditions there is some demand for watches, and the present season is not an exception. Filled watches have been better "Sellers" than usual and we have an attractive assortment of same, besides all grades of movements, and can attend to your wants promptly and efficiently.

Our medium priced line of gold jewelry is exactly suitable for the requirements of the Spring trade, and our "Sellers" will help to swell *your* sales.

"Sellers
of
Sellers"

HENRY FREUND & BRO.

71 Nassau St., NEW YORK

Watches
Diamonds
Jewelry,

ELK AND F. O. EAGLE
GOODS A SPECIALTY



Our Trade-Mark  "The Rose," stands for quality and excellence

The Bowden Rings

ARE COMPLETE IN VARIETY, CORRECT IN
QUALITY AND PERFECT IN FINISH. WE
MAKE EVERY VARIETY OF FINGER RINGS.

J. B. BOWDEN & CO.,

1 Maiden Lane,

NEW YORK.

The "Bryant" Rings.

WE have made the **Bryant Rings** for 50 years, and know how to make first class goods. The stone setting—which every retailer knows is a very important part of the work—we give special attention to. The **Bryant Rings** will help your reputation as a first class Jeweler.



TRADE-MARK

M. B. BRYANT & Co.,

No. 7 MAIDEN LANE,
NEW YORK.

The KREMENTZ MATCH BOX

made expressly for paper matches, in 14-Kt. Gold and Sterling Silver, with the following finishes:
Roman, polished, engraved, engine turned and the Krementz gun metal finish.

Open



Side View
Closed



Order No.
in 14-Kt. Gold
2117

Front View
Closed



Order No.
in
Sterling
Silver
2043

The side and front views show its compactness. It opens and closes easily and fits the vest pocket, taking very little space.

KREMENTZ & CO.

Manufacturers of

Fine Gold and Enamel Diamond Jewelry in 14-Kt. Only

MADE EXCLUSIVELY FOR FINE RETAIL JEWELRY TRADE

BRANCH
San Francisco Office
722 Shreve Bldg.

Factory and Main Office
NEWARK, N. J.

BRANCH
New York Office
1 Maiden Lane

POINT OF VIEW IN COLLAR BUTTONS



THE MAN who wears it is the one the Collar Button means most to. What is said about it is not so important as how it wears, whether it is comfortable, smooth, shapely and strong. Durand Collar Buttons have these virtues. No mechanism; no bother. They keep the friends they make.



PRICES: \$1.15 to \$4.00

DURAND & CO.

49-51 FRANKLIN STREET
NEWARK, N. J.



OSMUN-PARKER MFG. CO.

MAKERS OF

Fine Pearl and Diamond Goods

338 Mulberry Street
NEWARK, N. J.

ENOS RICHARDSON & CO.

23 Maiden Lane



New York, N. Y.

Trade-Mark

MANUFACTURERS OF
14 K. GOLD JEWELRY

- | | | |
|-------------|-----------------|------------|
| Handy Pins | Dumb-Bell Links | Hat Pins |
| Safety Pins | Fobs | Scarf Pins |
| Brooches | Tie Clasps | Barrettes |
| Flat Links | Veil Pins | Belt Pins |

10 K. and 14 K. Neck Chains
and Guard Chains

Plain and Jeweled Lorgnette Chains



The R. S. Cigar Cutter

In Sterling Silver, Plain and Engraved; and 14 k. Gold, Plain and Engraved, also Set with Diamonds.

A Novelty

Unlike all other cigar cutters, this one lies flat in the pocket—does not get out of order.

A Good Article



We Push It

Our advertising makes the customer want it; his friend sees it and he wants it. An endless chain of customers.

A Good Seller



Trade supplied by

Enos Richardson & Co.

23 Maiden Lane, New York.

C. R. HOWE
W. T. CARTER
W. T. GOUGH

ESTABLISHED 1841 BY A. CARTER

F. R. HORTON
F. W. STANBROUGH
H. L. FARROW

CARTER, HOWE & CO.

MANUFACTURERS OF

GOLD JEWELRY

ARTISTIC—SALABLE—RELIABLE

Most Comprehensive Line Offered

9-11-13 Maiden Lane, New York

Factory, Newark, New Jersey



SOLID GOLD BUCKLES AND SASH PINS

PLAIN AND ENGRAVED



14 K. — Everything in Gold Jewelry — 10 K.

Brooches, Links, Bracelets, Scarfs,
Fobs, Locketts, Hat Pins, Festoons,
Emblems, Gold Novelties, Pendants,
Earrings, Combs, etc.



2 Maiden Lane, New York

I. N. LEVINSON, President

ESTABLISHED 1865

H. S. MORRIS, Sec. and Treas.

S. COTTLE COMPANY

Makers of High-Grade Gold, Silver, Gun Metal Novelties

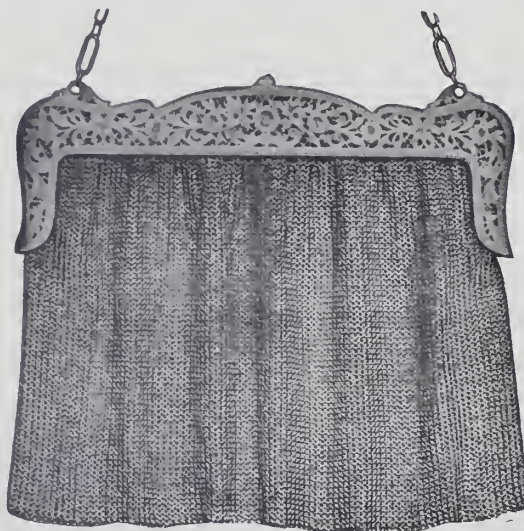

- Mesh Bags
- Buckles
- Card Cases
- Chatelaines
- Vanity Cases
- Sash Pins
- Purses
- Hat Pins

S. COTTLE CO.

31 EAST 17th STREET
NEW YORK

PARIS, 28 Rue D'Hauteville



Geo. O. Street & Sons

35 Maiden Lane, New York

Established 1837

RINGS
SLEEVE-LINKS
SCARF-PINS
FOBS AND SEALS

UNIQUE GEMS

I am showing an entire new lot of NATIVE, CEYLON,
URAL and BRAZIL semi-precious stones, in new and
fancy cuttings as well as cabochons. ALL GENUINE.
Sample papers sent to reliable dealers.

Louis J. Deacon, CAPE MAY N. J.
(Summer headq'ters)



SNOW & WESTCOTT CO.

21 MAIDEN LANE, NEW YORK

JAMES P. SNOW

CHAS. E. WESTCOTT

Makers of Fine Gold
Jewelry

ESTABLISHED 1834

It is said—

Times are Hard!

If this is so—

Try our SPRING CATALOGUE

This is an exceptional SPRING. Mostly all the Jewelers are talking about the business depression. You can get the business by ADVERTISING. This is an exceptional proposition for the JEWELER. Your name only appears on CATALOGUE. Send for sample COPY.

THE KELLER JEWELRY MFG. CO.

64 Nassau Street, New York

Factory, NEWARK, N. J.

“THE BRACELET HOUSE”

GOLD BRACELETS of every kind
For WOMAN, MISS OR BABY

KENT & WOODLAND

16 John Street, New York

Factory, Newark, N. J.

San Francisco: Julius A. Young



SEED-PEARL NECKLACES IN ALL SIZES.

OSMERS-DOUGHERTY CO.

MANUFACTURING JEWELERS

291-293 SEVENTH AVE., NEW YORK

Bet. 26th and 27th Sts. Telephone, 913 Madison.

DEALERS IN

BAROQUES, PEARLS and
FANCY STONES



DESIGNING

AND

SPECIAL ORDER WORK

Ludwig Nissen & Co.

182 and 184 BROADWAY
NEW YORK

PEARL
NECKLACES
AND
DIAMOND
COLLARETTES

Mounted Diamond
Jewelry of Every
description :: ::

Largest assortment
of all kinds of very
fine, fancy and rare
gems, including
Pearls, Diamonds,
Emeralds and
Sapphires :: ::

PARTICULARLY
FANCY COLORED
AND FANCY
SHAPED DIAMONDS

Ludwig Nissen & Co.

182 and 184 BROADWAY
NEW YORK

A Season of Staples

THIS is a season of staples. There will be buying, of course, but it will be along established lines. It is in such lines that this house takes a foremost place.

For example:

BEAD
NECKLACES

SASH
BUCKLE PINS
BELT BUCKLES

VEIL AND HANDY
PINS

BARRETTES

HAT PINS

COMBS

SCARF PINS

LINK BUTTONS



Day, Clark & Co.

14-Kt. Gold Jewelry

23 Maiden Lane
NEW YORK



Mourning
Goods
of all kinds

Bracelets
Brooches
Scarf Pins
Buttons
Studs
Necklaces
Everything
in Black

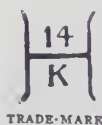

A. J. HEDGES & CO.

Makers of 14K. Jewelry

14 John St., NEW YORK

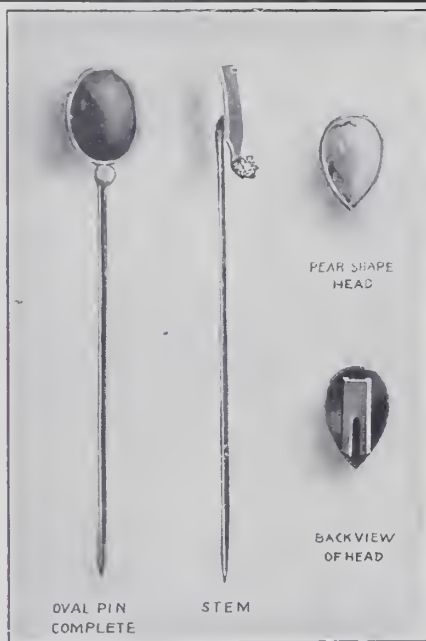

Interchangeable Scarf Pin

PATENT PENDING

Every smart dresser wears a scarf pin to harmonize with his cravat. Our new device allows the wearer to use a one-stone diamond in combination with any other colored stone, such as Lapis Lazuli, Moonstone, Turquoise Matrix, Jade, Topaz, Amethyst, Garnet, etc., by merely sliding the colored stone on the pin, as shown in illustration. Easy to attach or detach—nothing to break. Made in 14 Kt. only.

ROTHSCHILD BROS. & CO.

TRADE MARK.



The Locket House 51-53 Maiden Lane, New York

CHARLES M. PRIOR, Designer

Designs for Gold and Silversmiths.

I have added Ornamental Engraving to my Etching Department.

Phone 1639 Gramercy

24-26 East 21st St., NEW YORK

"If It Is Chopard's Idea, It's Ideal"



Combs

They are without question the biggest profit earners of the season and represent the highest art in comb making, and finest workmanship in setting. We have every style; steel, silver and gold-plated, set with cameos, white and colored stones, as well as a complete assortment of jet combs in both dull and bright.

Remember, we have anything you may require in Novelty Jewelry, Jet and Pearl Strings in stock.

Selection to all reliable dealers upon request.

CHOPARD FRÈRES CO., 56 Maiden Lane, NEW YORK, N. Y.
Factory, 35 Rue des Trois Bornes, PARIS, FRANCE

BROOCHES

Just now cameo and single stone Brooches are holding the center of the stage, and every Jobber should have at least a few numbers in his lines this spring. The business conditions make it necessary for you to keep abreast of the times. Let us send you a few samples on memorandum.

10K THIS TRADE-MARK on every piece of jewelry that leaves our factory. A medium-priced line of 10K. jewelry that has stood the test. Will say no more, but let us show you and be convinced yourself.

Send for further information regarding our extensive line.



1109



1110 Amazonite

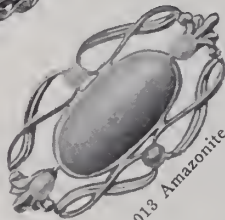

1013 Amazonite

W. E. RICHARDS CO.

Manufacturers for the Jobbing Trade
ATTLEBORO, MASS.

New York Office: 12-14 John Street

Samples only



306

S. PITZELE

Established 1893

51-53 Maiden Lane, New York

MANUFACTURER OF

FINE DIAMOND MOUNTINGS

Also BRACELETS and DWT. GOODS

SPECIAL ATTENTION GIVEN TO ORDER WORK



325



218

TRADE **14K** MARK



435

THE BEST
SOLID GOLD CHAINS

THE CHEAPEST

They stand the test of time and have done so for 56 years.

Supreme in
QUALITY
DESIGN
FINISH
WORKMANSHIP



We Sell Direct. We Have No Salesmen. Eliminating all unnecessary expenses in making and selling enables us to sell at the lowest possible price. Send for catalogue.

Trade  Mark

1850 1907

ALOIS KOHN & CO.

16-18 Maiden Lane, New York

Makers of **Gold Chains** of every kind.

ARREAUD & GRISER
68 & 70 Nassau St., New York
LAPIDARIES. PRECIOUS STONES
GEMS in Unique Cuttings



Pat.
U.S. and
Canada.

A MILLION RINGS ARE NOW worn that are loose on the finger and need Wells Perfect Ring Adjusters to hold them in place. Why not fit these and make a good profit and new customers.

Ask your Jobber for them Sold in 1 doz. assorted sizes in packages as follows: 10 K. Gold, \$3.75; Gold Filled, \$2.00; Metal, 85 cents.

CHESTER H. WELLS, Jeweler, Meshoppen, Pa.

Hat Pins

A large variety of novel and unique designs mounted with amethyst, topaz, lapis, coral, nephrite, etc.

As a special we offer genuine amethyst, topaz, crystal and lapis pins at a low figure.

Send for selection, mentioning price.



Fans in endless variety from the cheapest to the best for weddings, confirmation and graduation.

Necklaces, Buckles, Belt Pins, Brooches, Collars, Fan and Lorgnette Chains, Pearl Button and Pearl Drop Earrings, also choice specimens in Cameos.

LEWY & COHEN

IMPORTERS

530 Broadway Cor. Spring St.
NEW YORK

S. F. Myers & Co.

WHOLESALE JEWELERS
47-49 Maiden Lane
New York

The good store of yesterday is out of date to-morrow. Eternal effort is the price of progress. We are up to the minute.

For the trade only — our new, big catalogue, with 100,000 items, sent free.



Send for the Latest Styles in MONOGRAMS AND INITIALS

as manufactured by

THOMAS J. DUNN CO.

101 Chambers St., New York

Makers of exclusive styles in

MONOGRAM FOBS

in Gold, Sterling and Rolled Gold Plate. Our 1908 Ladies' Belt Buckles are most original and artistic.

Specialties in the Monogram and Initial line.

Send for Illustrated Sheets.



Roger Williams Silver Co.

Manufacturers of

The only practical Grape Fruit Knife and Anti-septic Shears; also Makers of the Common Sense Orange Knife.

See that Curve? (See cut) A child can use them.

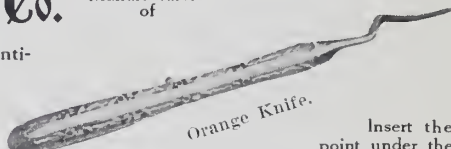

Insert the point under the outer skin, having the cutting edge toward you, and follow around, paring the cut skin without puncturing the inside pulp.

Samples and prices on application to the Factory

101 Sabin Street Providence, R. I.

Shell Cameo Brooches and Belt Pins

IN STERLING SILVER FLORENTINE WORK

FROM

\$3.25 to \$7.00 Each



While in Italy I anticipated the daily growing demand for Cameos, and accordingly negotiated for such quantities as now enable me to uninterruptedly meet the heavy call for these goods.

M. GUGENHEIM, Importer

Brooches, Festoon Chains, Combs, Hat Pins, Collars, Jet Goods, Mesh Bags, in German Silver, Gilt Metal and Sterling

NEW YORK OFFICE

33 Union Square, Decker Building

PARIS

32 Faubourg Poissoniere

Send for a choice selection on memorandum

LOCKETS ONLY

Registered



U. S. Pat. Office



NUMBER
8489

Old English Style and Finish; Hand Decorated

WICHTMAN & HOUGH CO.

NEW YORK OFFICE
3 Malden Lane

Main Office and Factory } 7 Beverly St.
PROVIDENCE, R. I.

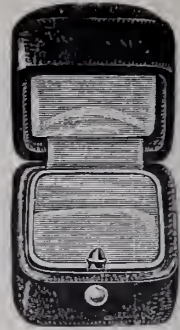

Fancy Platforms and Blocks for Window Display.

Trays, for Show Cases and Travelers' Use, of every description.

Jewelry Boxes in many qualities and styles.

Boxes for silverware. Manicure and Toilet Sets.

Silverware Chests in any combination.

Flannel Rolls and Bags for Silverware.

We Re-cover Window Platforms and Trays.

PAPER BOXES.

Tags, Cards, Cotton, Findings, Etc.

Estimates and Samples Cheerfully Furnished

WOLFSHEIM & SACHS

Office and Salesroom:

35 Maiden Lane,
(Lorsch Building)

NEW YORK

Factory: 10 Gold Street, N. Y.



ALL KINDS OF

INITIALS

ORNAMENTS

AND
MONOGRAMS

Inlaid in

TOILET
ARTICLES
CANES
UMBRELLAS
ETC.

as shown in the
illustration here-
with l u s h with
the wood.

Waldron & Carroll

34 WARREN ST.
NEW YORK CITY

A NEW CREATION IN Hat Pins

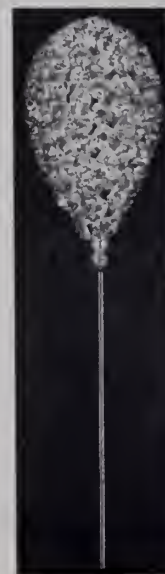

Made of the finest
brilliant Rhinestones.
Can be sold for less
than the imported
ones. They come in
pear, ball and half
ball, octagon and
heart shapes, and can
be retailed from

50c.
to
\$5.00

at a handsome profit.
Ask your jobber or
write us for sample
assortment.

ACME COMB AND
NOVELTY CO.
Manufacturers

Factory and Office
147 Spring St., New York
Salesroom: 194 Broadway

WE WILL RESUME OUR OLD ADDRESS

¶ One year ago, we left our headquarters of twenty years' standing, to make room for the handsome structure now occupying the site of 15-19 Maiden Lane.

¶ On May 1st, we will occupy our handso, menew quarters, and extend to the trade and our friends in general, a cordial invitation to visit us, and see the growth and development in the distribution of the following well-known lines, the output of our large and well-equipped factories.

A. L. Co. Gold Pens
Mercantile Fountain Pens
Mercantile "Self-Fillers"
"Beacon" Stylographic Pens
Gold and Silver Pen Holders
Gold and Silver Pencils
"Universal" Outfits
Gold and Silver Penknives
Cigar Piercers, Etc., Etc.

SEND FOR COMPLETE CATALOGUES
TO-DAY

Aikin-Lambert Co.

Established 1864

15-19 Maiden Lane, NEW YORK

Important Notice

¶ The jewelry trade is hereby notified that the following manufacturing jewelers have been granted licenses under my pending patents to manufacture and sell the "Fashion" Collar Pins:



KREMENTZ & CO.
CARTER, HOWE & CO.
BIPPART, GRISCOM & OSBORN
A. J. HEDGES & CO.
ECKFELDT & ACKLEY
J. T. MAURAN MFG. CO.
WOLCOTT MFG. CO.
ARCH CROWN MFG. CO.
SCHRADER-WITTSTEIN CO.
THEO. W. FOSTER & BRO. CO.

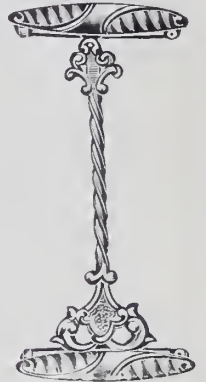

The trade is informed that I shall protect our rights under my pending patents to the full extent of the law, and having confidence in the fairness of the trade in general, I believe that I may expect its co-operation by refusal to purchase should other manufacturers than those above mentioned offer "Fashion" Collar Pins in imitation of mine.

Thanking the trade in advance for its consideration, I beg to remain, very respectfully,

CHARLES T. WITTSTEIN

ARCH CROWN MANUFACTURING CO., Camp & Orchard Sts., Newark, N. J.



"HOLD-ON" CLUTCH



FOR SCARF PINS AND BROOCHES



14K. GOLD PLATE
SUPERIOR TO ALL OTHERS

Pat. May 20, '02
To Release
Pull the Ball

PRICE 50 CENTS

Pat. May 20, '02
Attached
to Scarf Pin

ADVANTAGES:

1. *It Holds*—The harder you pull, the tighter it holds.
2. *To Release*—Raise the clutch and pull the ball.
3. *All One Piece*—No parts to lose.

HOLD-ON CLUTCH CO. 33 GOLD STREET NEW YORK

10K. GOLD BRACELETS

New and Original
— Designs in —

**BANGLE, JOINT
AND
CATCH SIZES**

Scarf Pins, Ladies' Rings
Earrings and Handy Pins

in a great variety
of designs

TRADE MARK

**THE
Edwin Lowe & Co., Inc.**

F.W. BODWELL, Pres. & Gen. Mgr.

116 Chestnut St., PROVIDENCE, R. I.

New York Representative: Western Representative:
E. T. Wilson, 180 Bway. S. H. Brewer

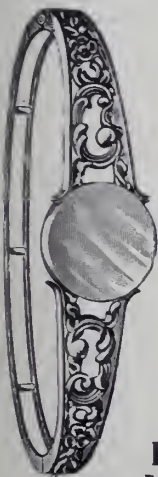

P & B BABY PINS



BABY PINS—ALL DESIGNS
SUITABLE FOR BABIES OR GROWN-UPS

We are the Largest Exclusive Makers of 10 K. Jewelry

Ask your jobber for the P. & B. Lines of Cuff Buttons, Crosses, Bead Necks, Tie Clasps, Brooches, Baby Pins, Scarf Pins, Bracelets, Locketts and Fobs.

NEW YORK OFFICE, -- 65 NASSAU ST.

POTTER & BUFFINTON CO.

PROVIDENCE, R. I.



Roller Chain

OUR SPECIALTY

Do not forget that we still continue to show the best line of these goods on the market, in Fobs, Bracelets and Neck Chains. These wear longer, give better satisfaction than any metal fob made, and our designs are up-to-date. Also our line of chains of all kinds find a ready market among the best trade, both in 1-10 and a medium wearing grade.

We also make a nice line of Brooches, Hatpins, Scarfpins, Barrettes, etc., that should demand your attention.

Ask your jobber, and if unable to obtain them from him, advise us who he is, and we will make arrangements for you to get them.

B. S. FREEMAN CO.

ATTLEBORO FALLS, MASS.

Chicago Office, J. T. Edwards, 103 State St., Chicago, Ill.

R I B B O N S

plain and fancy designs **Made to Order**, in large or small quantities, to use with medals and for club purposes. :: :: :: Correspondence invited.

JOSEPH LOTH & CO., Manufacturers, 65 Greene Street, New York

Perennially Popular

THE best evidence of the popularity of our various lines is the increasing demand for them and our consequent growth. Our jewelry is unexcelled in every quality that contributes to serviceability and appearance. The designs are artistic enough to court that investigation which results in sales.



Ask to see our line of

**CHAINS
CHAIN PENDANTS
CROSSES
AND BRACELETS**

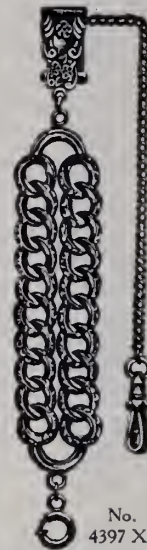

The
**Kenilworth
Bracelet**

particularly, the strongest
on the market.

**DORAN,
BAGNALL & CO.**

North Attleboro, Mass.

OFFICES

New York: 194 Broadway.
Chicago: 42 E. Madison St.
San Francisco: 91 Drumm St.



THE R. & L. OIL

The R. & L. Oil is made especially for those expert watch and clock makers who must have the best and most reliable oil on the market. It does not gum or change, and possesses all the requisites needed for the most delicate mechanisms. Send 25c. to your jobber, asking for R. & L. Oil.

Wholesale Selling Agents

M. SICKLES & SONS	Philadelphia
SWARTCHILD & CO.	Chicago
NORDMAN BROTHERS CO.,	San Francisco
D. C. PERCIVAL & CO.	Boston
CHAS. MAY & SON	Boston
DANIEL PRATT'S SON	53 Franklin Street, Boston
SUSSELD, LORSCH & CO.,	New York City
H. S. MEISKEY CO.	Lancaster Pa.

RANLETT & LOWELL CO.

SOLE MANUFACTURERS
Jewelers' Building BOSTON, MASS.



After May First

Our New York Office
will be

Rooms 1706 and 1707

Silversmiths' Building

15-17-19 Maiden Lane

Telephone Connection

**E. L. SPENCER
COMPANY**

**Makers of
Solid Gold Jewelry**

Factory:
95 Chestnut St., Providence, R. I.



Athletic Medals Trophies Awards for Scholarships, etc.

PRIZES FOR ALL TOURNAMENTS AND MEETS

We can help you secure that local order

The Chas. M. Robbins Co.

ATTLEBORO, MASSACHUSETTS





Salesmen start soon with the FALL LINE. You'll be "in" profits if you wait.

S. & B. LEDERER CO.

QUALITY WEARS GOODASGOLD

New York City: 9-11-13 Maiden Lane

Providence, R. I.: 100 Stewart St.

Chicago, Ill.: 131 Wabash Ave

PERPETUAL PERFECTION

PRESUMING that you are in business for PROFITS — it follows that you should always sell

VERIBEST

Lifetime



Guaranteed

LOCKETS

EVERYTHING IN LOCKETS AND CHAINS.

THE BASSETT JEWELRY CO.,

PROVIDENCE, R. I.

DIAMOND MOUNTINGS

of any description in gold and platina

Order Work a Specialty

HENRY BASCHKOPF

47-49 Maiden Lane

New York, N. Y.

Pierceless Ear Screws

We are making a complete line of these popular goods. Samples upon request.

Also a new line of

Brooches
Scarf Pins
Baby Pins
Links
Studs
Crosses
Ear Rings
Rings
Neck Chains

We have manufactured Gold jewelry for over fifty years and our goods have stood the test of time.

DON'T NEGLECT TO
SEE OUR LINE.

Wm. C. Greene Co.

Established 1849

Incorporated 1906

MANUFACTURERS OF
GOLD JEWELRY

101 Sabin Street,

Providence, R.I.

Cable Address: "LEOGOLDIE" N. Y.

Telephone, 4115 Cortlandt Amsterdam, 2 Tulp St.
Paris, 27 Rue Drouot.

LEO. GOLDSMITH

IMPORTER OF

Diamonds and Precious Stones
9, 11 & 13 Maiden Lane, N. Y.

Diamonds, Rubies, Sapphires, Emeralds,
Opals, Olivines, Pearls, Half-Pearls, Tur-
quoises, Reconstructed Rubies, Recon-
structed Sapphires.

Gems and Precious Stones

Cloth, Postpaid, \$1.00. Published by the Jew-
elers' Circular Pub. Co., 11 John St., New York.

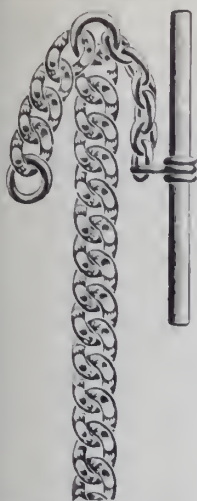

O. M. DRAPER CHAINS

ALL KINDS OF VEST CHAINS
PRINCESS, NECK AND GUARD CHAINS

We do not make as much noise as some of our friends but we are "there with the goods" and the *Jobbing Trade* handling our product for the last half century, know that our QUALITIES are genuine and can be depended upon, that our FINISH is unparalleled and that our prices are consistent.

If you do not handle O. M. DRAPER GOODS, we both lose.
We sell only to the Jobbing Trade.

Estate of O. M. DRAPER

Factory, No. Attleboro, Mass.

NEW YORK OFFICE
37 Maiden Lane

SAN FRANCISCO
506 Chronicle Building



THE WASHBURN

SECURITY
Automatic Holder
for all sizes of scarf-pin wire. Guaranteed.

MAGIC NUT
for ear studs, scarf-pins etc.



EAR WIRES
for unpierced ears.



SAFETY CATCH
For Brooches, etc.
Can be applied to any work where pin tongues are used.



Open. Closed. Open. Closed.
Descriptive Circular on Application.

Pearl Drilling and Adjusting a specialty.
Special Order Work and Repairing.

C. IRVING WASHBURN, 12-16 John St., N. Y.

THE CROHN PATENT SAFETY GUARD



For Scarf Pins, Pins. The most adjustable one invented. Price, \$1.50 per doz. For sale by all wholesale jewelers and material houses. Sample by mail, 25c.; in 10k. gold, \$1.00; 14k., \$1.25. M. CROHN Maker and Inventor, 43 and 50 Maiden Lane, N. Y.

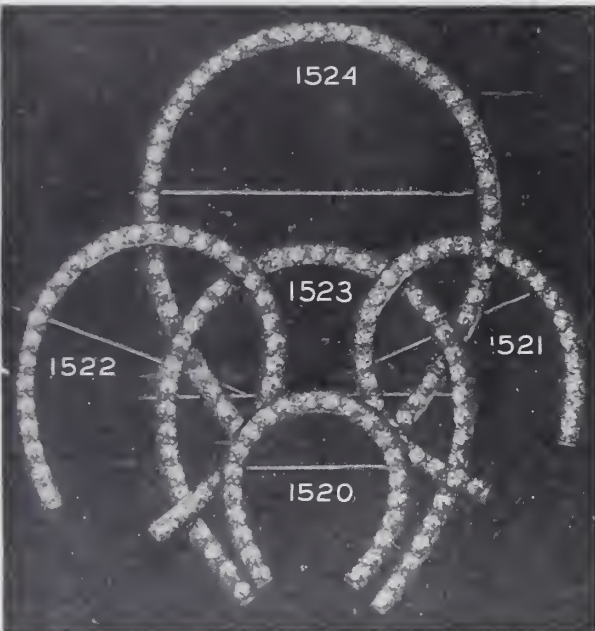

Sterling Silver Horseshoes

14 Karat Gold Finish set with Whitestones or Pearls

Write for Selection Package with Prices

Wachenheimer Bros. 36 GARNET STREET PROVIDENCE, R. I.



Veil, Cuff and Baby Pins

An immense line. Many new designs supplementing our staple patterns—all of acknowledged beauty and easily sold.

Cameos A revival of an old-style decoration too good to remain in oblivion.
Shell, Coral and others, mounted as Brooches, Stick Pins, etc.

Swastika Buckles Bracelets Buttons Charms Brooches Barrettes
Combs, Hat Pins, Scarf Pins, Leather Trimmings

MILLER, FULLER & WHITING CO.
Manufacturing Jewelers

New York Office, 9-11 Maiden Lane NORTH ATTLEBORO, MASS.
WE SELL TO THE JOBBING TRADE ONLY





NEW YORK OFFICE
No. 7 Maiden Lane

CHICAGO OFFICE
1203 Heyworth Building



Seamless Gold Plated Pins

FOR EVERY USE

Variety of Patterns in Plain and Engraved, in lengths one to four inches : : : : :

GUARANTEED GOLD FRONT, BACK AND SIDES

SEND FOR SELECTION

Maintien Bros. & Elliot, Makers of Jewelry for the Jobbing Trade

NO. ATTLEBORO, MASS.

New York Office, 9-11 Maiden Lane



Chicago Art Metal Works
Manufacturers of

INITIALS and MONOGRAMS

FOR PURSES, BAGS, BRUSHES, ETC.

Monogram Fobs and Belt Buckles

Write for Catalogue and Prices

63 Lake St., Chicago, Ill.



The Gillette Safety Razor Set consists of a triple silver-plated holder and twelve double edged, thin, flexible, wafer-like blades (24 keen edges), packed in a velvet lined leather case. Price, \$5.00. Also made in Combination Sets in a variety of styles with toilet accessories retailing from \$6.50 to \$50.00 each.

Would You Have the Present Year Bring You Increased Patronage, Profit and Prosperity?

Do you realize that nearly every hour in the day some man is converted to the easier, quicker and more economical way of shaving himself with the

Gillette Safety Razor?

Our persistent and vigorous advertising in the leading publications of this country discloses — *and will continue to disclose* — beyond all question of doubt, the superiority of the "Gillette." It advocates the advantages of self-shaving and guides the man to your store with a five dollar bill to exchange for the best shaving device in this world.

You can readily see the wisdom of having the "Gillette" ready when he calls. The Standard Gillette Set retails at \$5.00 everywhere. Combination Sets from \$6.50 to \$50.00. Keep a good supply in stock. Write to-day for valuable selling information and prices.

GILLETTE SALES CO., 904 Times Bldg., New York City

Jewelry which gives Distinct Pleasure to its Wearer

This can be truthfully said of the F. & B. New Fashion Collar Pin and Supporter. The lower pin and support are in one piece, the upper pin being movable, and the entire support is worn on the outside of the collar, thereby adding a dainty touch to the Ladies' neckwear, and at the same time doing away with uncomfortable inner support. With many unique designs we are now ready for the Spring Season's orders.



1½ in. high No. 3963
2 " " 3969
2¼ " " 3975

THE "FASHION" PIN

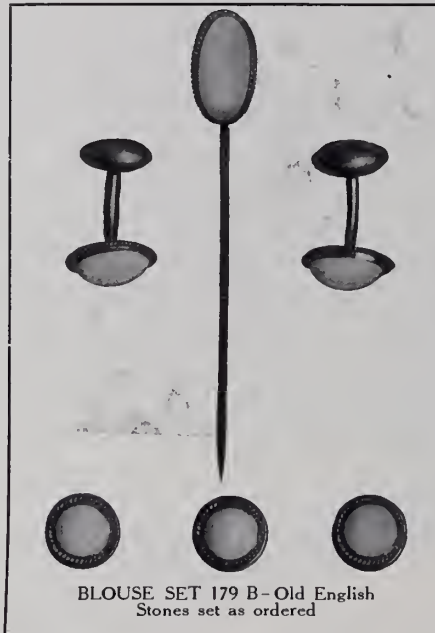

BLOUSE SET 179 B—Old English
Stones set as ordered



1½ in. high No. 3965
2 " " 3971
2¼ " " 3977

THE "FASHION" PIN

FINE GOLD FILLED COLLAR PINS. PATENTS PENDING

The practice of keeping to one color scheme in Jewelry is becoming an established fashion. Our New Blouse Sets, made up of Studs, Link Buttons and a Scarf Pin, all set with stones of the same shade, make pretty ornaments for the Summer Gowns.

We have, besides, a handsome line of Locketts and Chains, Bracelets and Link Buttons, Veil and Scarf Pins, Hat Pins and Brooch Pins, as well as Neck Chains and Pendants.

Our Sterling Silver Goods afford a choice selection of Toilet and Manicure Pieces, Table Ware, Vases and Candle Holders, suitable for June Weddings and Graduating Gifts.

Theodore W. Foster & Bro. Co.

Manufacturing Jewelers and Silversmiths

100 RICHMOND ST., PROVIDENCE, R. I.

NEW YORK: 13 Maiden Lane

CHICAGO: Heyworth Bldg.

CANADA: Kingston, Ontario

THE JEWELERS' CIRCULAR

WITH WHICH ARE CONSOLIDATED
 THE HOROLOGICAL REVIEW
 THE JEWELERS' WEEKLY THE JEWELERS REVIEW

VOL. LVI.

WEDNESDAY, APRIL 22, 1908.

No. 12.

Handsome Casket and Jeweled Key Made at San Diego, Cal., For Rear Admiral R. D. Evans.

THERE was recently completed at a San Diego, Cal., jewelry establishment two articles which will have a world-wide interest, a casket and a key, as they are the first mementoes to come to Rear Admiral Evans on his fleet reaching that city, the first home port, after its long cruise around the Horn.

The larger object is a magnificent jewel casket of olive wood and silver, illustrated on the front page of this issue, which bears emblematic and historical designs. In dimensions the casket is six and one-half inches long, four inches in width and six and one-half inches high. There is used in its composition 21 ounces of silver. The

and olives and a cluster of grapes. The legs of the casket are finished and attached in 18th century style. On the four corners of the casket are large turquoises.

The key, shown herewith, which is of native gold, and contains an ounce of the precious metal, is an object of great beauty. It contains, in the bow, 22 pearls and two tourmalines, the larger of which is pink and weighs five carats, while the smaller, almost a true emerald hue, weighs three-fourths of a carat.

Perhaps the most distinctive feature of the gifts is the fact that from metal to gems, even to the white silk lining of the casket, only native products are used in their composition and finish. This shows something of the multiplicity of resources which San Diego County possesses.

The entire designing and manufacturing of these tokens of San Diego's welcome to the Admiral have been done by J. Jessop & Sons, and many high commendations have been received by them as the result of their handiwork. The casket and key represent an outlay of approximately \$500.

A. H. W.

Jewelry in San Salvador.

IN transmitting the following information Consul-General Samuel E. Magill reports that there are only three jewelry stores in the city of San Salvador, which is accounted for on the supposition that the rich Salvadorans while traveling abroad purchase their jewelry in New York and Paris:

The jewelry on sale in the three jewelry stores of San Salvador is about as follows: Solid silver articles consist chiefly of fruit spoons, cups, hand mirrors, napkin rings, toilet articles, etc., and are purchased principally from American manufacturers because of the fineness of design and workmanship. The only criticism made by the trade here is that they are too heavy; a lighter article of the same designs and finish which would be cheaper would find a readier sale and be just as satisfactory to the purchaser, as such articles are bought chiefly for presents, and the question of durability is of less importance than that of appearance.

The United States and Germany furnish plated ware in about equal amounts, that from the former being preferred on account of quality. In the matter of cost there is little or no difference; therefore it is only to have variety of style for the retail trade that purchases are made in both countries.

American and Swiss watches are purchased in about equal numbers, as the retail trade seems equally divided between the

two makes. The dealers state that they prefer to sell the American watch, for the reason that when repairs thereon are necessary the broken parts can be more easily replaced, for parts of American watches can be purchased in quantities, while those of Swiss watches can not.

Clocks come from the United States on account of the better quality of the works. This is true of both those with wooden and fancy metal and glass cases. A few German clocks are carried on account of novel designs in the cases, but in all other points American clocks appear to excel, and they seem also to be less affected by seismic disturbances, so common here.

Gold-plated buttons, cuff buttons, scarf pins, with and without stones, come from Austria, whose dealers offer a variety of style at prices less than those offered by American houses. Pens, plated pins and patent buttons are purchased in the United States because they are regarded as better and cheaper. Plated watch chains are largely of German make because cheaper, and the trade here demands low-priced goods in that line.

Solid gold rings, scarf pins, breast pins and other solid settings come equally from the United States and Germany, each having certain advantages which make it advisable to keep both kinds in stock. Prices are about the same.

The finer grades of knives and forks are purchased in the United States because of their quality and finish, while in the ordinary and common grades the prices of German goods are lower than those offered by American houses.

Eye-glass crystals are entirely of American make, because of quality and price; eye-glass frames come in equal quantities from Germany and the United States. Although the German frames can be purchased at a lower price, orders placed in the United States are filled more promptly.

Precious stones are purchased in Europe. Fancy porcelain and religious figures and centerpieces for flowers, etc., are of German and Austrian make.

Goods for shipment to Salvador should be packed in cases as light in weight as possible consistent with the safety of their contents, as the import duties are collected on the gross weight of all packages. Orders should be filled exactly as sent and no substituting of articles "equally as good." Insurance should cover all losses, including even robbery.

Notice is given of a proposed private sale of the property of Jacob A. Moller, New Rochelle, N. Y., who went into bankruptcy some time ago. There will be a hearing in regard to the proposed sale at the office of Referee Thayer, Yonkers, N. Y., April 24. The property proposed to be sold consists of a stock of silverware and cut glass, materials for manufacture and articles in process of manufacture.



JEWELED KEY PRESENTED TO ADMIRAL EVANS.

lid of the casket bears a model in silver of one of the galleons of Cabrillo, the first white man to make known the beauties of San Diego's bay.

On the front panel is a life buoy, with a hanging monogram bearing Admiral Evans' initials. The whole is supported by an anchor. On a ribbon across the front of the panel is the inscription: "City of San Diego, California, 1908." On one end is a representation of the old San Diego Mission, built in the 18th century, and on the opposite end are shown the old palms, planted by the Spanish padres in 1769, and the mission bells, brought over from Spain prior to that date.

The rear of the casket bears a representation of a naval vessel, also in silver work. Other distinctive features of the decorations are sprays of lemons, oranges

Recent Decisions by General Appraisers as to Duty on Jewelry, Gems, and Kindred Lines.

Decisions of the Board of United States General Appraisers, New York, in cases involving the duty on jewelry and kindred lines have been announced in the last week as follows:

JEWELRY.—Protest of Samstag & Hilder Bros., New York. Opinion by Sharretts, G. A. 6389 (T. D. 27420) followed.

FOIL-BACK JEWELS.—Protests of Morris Goldberg, New York. Protests sustained as to foil-back jewels. G. A. 6380 (T. D. 27420) followed.

IMITATION PRECIOUS STONES.—Protest of A. Lorsch & Co., New York. Protest sustained as to imitation precious stones. G. A. 6088 (T. D. 26554) and G. A. 6155 (T. D. 26723) followed.

WAX BEADS.—Protests of Guthman, Solomons & Co. and protests of H. E. Frankenberg Co. et al., New York. Protests sustained as to wax beads. G. A. 6639 (T. D. 28297) followed.

TOY NECKLACES.—Protests of Guthman, Solomons & Co. and protest of Strauss Bros. & Co., New York. These protests related to articles classified as jewelry. The assessment was affirmed except as to beaded necklaces valued at less than 11 marks per gross. These were held dutiable as toys under Par. 418, Tariff Act of 1897, as claimed by the importers. G. A. 6297 (T. D. 27156) followed.

JEWELRY.—Protests of M. Goldberg, protest of Royal Metal Mfg. Co., protest of R. F. Lang, protest of L. W. Levy & Co., protests of Samstag & Hilder Bros. et al., protest of Siegel-Cooper Co., protests of A. Steinhardt & Bro. et al., and protest of Strauss Bros. & Co., New York, and protests of George Allen, Philadelphia. The merchandise was held to have been properly classified as jewelry under Par. 434, Tariff Act of 1897.

BEADED ARTICLES.—Protest of Horstmann, Von Hein & Co., protest of Lewy & Cohen, and protest of A. Steinhardt & Bro., New York. The goods were held to have been properly classified as beaded articles under Par. 408, Tariff Act of 1897.

RECONSTRUCTED STONES—WAX BEADS.—Protests of Albert Lorsch & Co., New York. Protests sustained as to reconstructed stones and wax beads. G. A. 6336 (T. D. 27278), G. A. 6637 (T. D. 28295) and G. A. 6639 (T. D. 28297) followed.

PINS—ORNAMENTS.—Protests of Veit, Son & Co. (New York), protests of F. B. Vandegrift & Co., Philadelphia, and protests of Lowengart & Co., Portland, Ore. The assessment was modified as to certain pins and millinery ornaments. G. A. 6139 (T. D. 26679) and G. A. 6374 (T. D. 27382) followed. In other respects the protests were overruled.

IMITATION CLOCKS AND REVOLVERS.—Protest of Mogi, Momonoi & Co., New York. The protest related to diminutive imitation clocks and revolvers, flimsy affairs costing about one cent apiece. The Board held that they were neither jewelry nor toys, but were dutiable as manufactures of metal, which was one of the claims made by the importers.

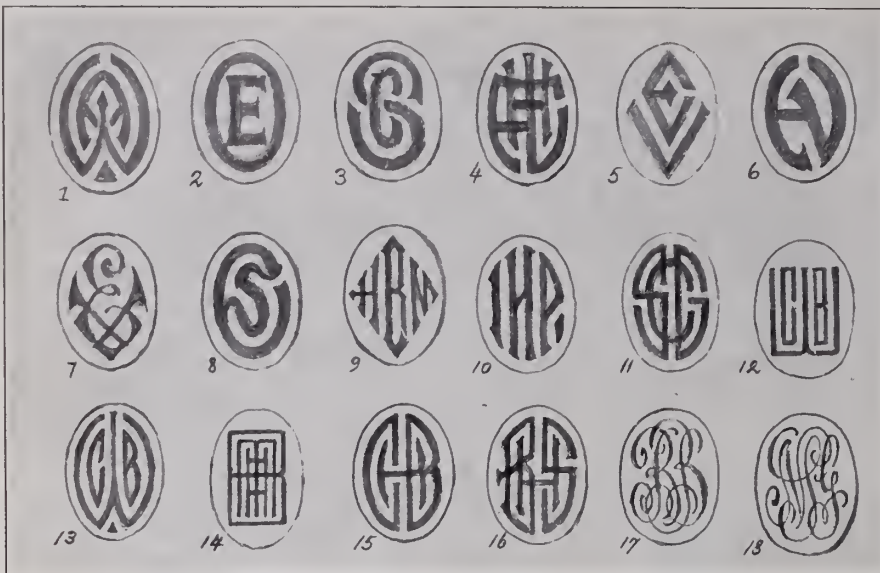

YOU may have a customer who has purchased a fine signet ring and desires to have his initials engraved on it with more character than just engraving them in the ordinary way, *i. e.* cutting the letters into the gold.

The above designs fill just such wants. We cut away the gold from the letters, leaving them in base relief, which adds materially to the appearance of the ring. Our price for two or three letter monograms is \$3.00 net; single letter, \$1.50 net; single letter on extra large plate, \$2.25 net.

LARTER & SONS

21-23 Maiden Lane, New York, N. Y.

TRADE-MARK



REGISTERED IN U. S. PATENT OFFICE

A MODERN CELLINI ON THE ISLAND OF CAPRI.

By Gardner Teall.

THROUGH all the vicissitudes of its fortunes, the island of Capri has remained the gem paramount of the Gulf of Naples. Despite Bourbon, and again English occupation, the Caprese have retained their customs, their traditions and their dialect throughout a succession of uninterrupted years of honest and simple living.

In so small an area (for Capri boasts of little over 2,500 acres), one does not look

of the Villa of Iberius, and that Capri is nothing more than the derelict plaything of those Roman emperors whose names are so everlastingly linked to its history.

Nevertheless, there is many an odd little nook and corner on highway and by-way, where the shuttle and loom, pattern and thread, hammer and glue, leather and mallet, and chisel and stone, are kept busy during the cool of the day with things that would delight the eye of any one fortunate enough to come across them.

But to me the greatest surprise of all was to find a modern Benvenuto Cellini working away with metal and melting-pot on the most fascinating objects of the silversmith's art after his own designs. I discovered him one May day morning, standing there in the doorway of his little shop on the Via Tragara, and the discovery seemed quite providential, as my favorite scarf pin had disappeared in Naples the week before (in the same mysterious manner, I suppose, common to half one's wardrobe in Italy!), and here was a chance to find something to the fancy to take its place.

Modestly Signor Zoppo displayed his handiwork—beautifully conceived pins, buckles, rings, seals and the like—from the window-case of his little shop. They were all in silver, he apologized, but some day he hoped the *signori* who visit the island, will make it possible for him to show gold things, too, for if he is not yet as consummate a craftsman as the Florentine Cellini of Italy's renaissance he is young and works hard, and there is much more to look forward to.

When I told him about my little pin the signore said: "I shall make you one and you shall see me make it," adding with delightful naïveté, "and it will, of course, be more beautiful than the other!" It was.

He first made the little design on paper and, when this step had been approved, deftly translated it into modeling wax.

With this he was wonderful, for I have never before, nor since, seen such hard, unruly and obstinate wax in my life. I am sure the *argentieri* of Florence, even, where much skill is primitive, would despise it! After that a mould was taken in plaster of paris, and finally we had a little "casting bee," when the metal from the crucible in his little furnace was poured into the mould. While it was cooling Leonardo, the clever young apprentice, ran around to the *Mecca of the Tedesci* and fetched the coffee with which we regaled ourselves. After that I came back to watch him finish the *spillo* with a few simple tools—a file or two, and then the pin was soldered on at a white heat and the whole thing plunged into a tiny acid bath to oxidize it, when, presto! I had in hand the thing of beauty that's a joy forever. I doubt if any craftsman ever took greater pains with a gift for Julius II. than this Capri craftsman took for me with this little pin.

And then there was no bickering or sput-



IN FRONT OF HIS STORE.

for great industrial enterprises, for which reason the casual visitor, perhaps, rushes through from a *giro*, recommended by his scarlet *vade-mecum*, concluding there is nothing of interest beyond the scanty ruins



THE FOUNDRY IN THE WALL.

tering about the price. It was so ridiculously low I feel apologetic every time I think of it!

You must not think Signore Zoppo confines himself to the patronage of the *forestieri*, for the *Caprese* takes quite as much interest in his work. They are critical, too, but it is good training for the master and it finally comes to little Leonardo.

Signore Zoppo's first aspiration was to become a founder of *objets d'art* in bronze, and he still makes beautiful statuettes and door handles for the villas of Elihu Vedder, C. Carrol Coleman, Lady Gordon Lennox and others, which villas, with their



DEALING WITH A CRITICAL CUSTOMER.

LOUIS KAHN

MOSES KAHN

SAMUEL H. LEVY

L. & M. Kahn & Co.

Importers and Cutters of

DIAMONDS

roadway, cor. Maiden Lane, New York

: 2 TULP STRAAT

CUTTING WORKS: 29 GOLD STREET

Arnstein Bros. & Co.

Importers and Cutters of

DIAMONDS

65 Nassau Street

New York

LONDON: Audrey House, Ely Place

AMSTERDAM: 6 Tulp Straat

ALBERT LORSCH

N. Y. Telephone Call, 2161-2 John

ALFRED KROWER

ALBERT LORSCH & CO.

LORSCH BUILDING, 37 and 39 MAIDEN LANE, NEW YORK

131 Washington Street, Providence, R. I.

Rose Diamonds

marvelous gardens adorn the island. The sign over his shop reads:

**Fonderia
In Bronzo
Bno. Zoppo**

Another day the master took me down to his foundry on the road to the Faragioni to watch the casting of a beautiful "Narcissus." Surely Benvenuto Cellini of the days gone by could not have stood more breathlessly over the molten metal for his famous "Perseus" than did Signore Zoppo over the mould of the "Narcissus." If ever you visit Capri you must look for this tiny foundry set in the wall of a beautiful garden on the Via Tragara the very road the proud Romans of other times traversed on their way to the luxurious villas.

We came back Leonardo behind silhouetted against the evening sky bearing the afternoon's treasure Italian-wise upon his head, which the next evening found hushed and ready to deliver to the Crown Princess of Sweden, who had ordered it. Surely this was bringing back the spirit of the old times, and I think if the shade of Tiberius haunts the island, as some of the *contadini* will assure you it does, it must sigh that it cannot be here in the flesh to become a patron to this Cellini of Capri.

Liabilities and Assets of Max Marcus, Chicago, as Shown by His Bankruptcy Schedules.

CHICAGO, April 17.—The schedules in bankruptcy of Max Marcus, doing business as Max Marcus & Co., wholesale jewelers, at 92 State St., who was petitioned in bankruptcy some weeks ago, show the creditors to be as follows:

Less than \$50—Hipp. Didisheim & Bro., Oscar Gottlob & Co., R. L. Griffith & Co., Horton, Angell Co., Morgan Jewelry Co., Rhode Island Novelty Co.

From \$50 to \$100—Geo. L. Brown & Co., Rodenberg & Dunn, J. M. Fischer & Co., Fontneau & Cook Co., A. Hirsch & Co., Edwin Lowe & Co., S. K. Merrill & Co., F. H. Sadler & Co., Geneva Optical Co.

From \$100 to \$200—Carter, Qvarnstrom & Remington, Doran, Bagnall & Co., W. S. Richards & Co., O. M. Draper estate, H. D. Merrit & Co., C. O. Sweet & Son Co.

The other creditors are: S. O. Bigney, \$1,306; W. & S. Blackinton Co., \$761; D. F. Briggs & Co., \$2,261; Finberg Mfg. Co., \$307; Leon Hirsch, \$327; Irons & Russell, \$392; Ostby & Barton Co., \$544; R. F. Simmons Co., \$559; Star Watch Case Co., \$757; Sussfeld, Lorsch & Co., \$3,302; Wightman & Hough, \$324; Untermeyer-Robbins Co., \$1,222; Byron L. Strassburger & Co., \$840; Philadelphia Watch Case Co., \$250.

E. M. Valentine, Mr. Marcus' former partner, is a creditor for \$350 balance due him for his share in the concern when Mr. Marcus and he separated. The total liabilities are \$16,175.

The estimated value of the assets is \$12,426. Mr. Marcus claims \$400 cash as exemption under the bankruptcy act.

ELSIE BEE'S FASHIONS.

SPRING NOVELTIES NOTED IN A LADY'S RAMBLES AMONG THE JEWELLERS.

A STRIKING pair of the drop earrings is made of amethyst briolettes, more than an inch in length, surmounted by cabochon stones of the same color.

* * *

An equally effective pair contains an emerald half an inch square at the base with a cabochon top. Above this and fitting close to the ear is a small diamond.

* * *

Another contrast is exemplified in the long drop earrings, one of which is a pear-shaped diamond about three-quarters of an inch in length, and the other is a yellow diamond, the color of a topaz.

* * *

A silver firm is exhibiting some new table silver. It is colonial in design, the decoration being a simple wreath. The silver plates and other articles of the service have also a charming simplicity of design.

* * *

As an illustration of the fact that the pearl still holds its own in this connection there is the pair of earrings in which one is set with a large black pearl and the other with a white pearl of the size of a marble.

* * *

Automobile red is the new color for leather goods. Russia leather of this rich shade, which is admirably adapted to almost all articles, is made into handbags of various shapes and sizes, bracelet bags, purses and memorandum and engagement books.

* * *

The glass beetles seen in a New York shop offer suggestions for the use of other materials similarly treated. The buckles, for instance, in which the peacock-colored beetle is set in a green gold foundation of Oriental design, are particularly suggestive. With these the belt is of hand-made braid that matches the soft tones of the beetle and the touches of enamel on the green gold.

* * *

There seems to be no longer any doubt about the fashion of earrings. They are gradually coming into more general use and the displays in some of the smart shops give evidence of their adoption. Not alone are the simple pearls and single diamonds that set close to the ear holding forth as the prevailing style, but there are enameled flowers, stones of all colors, sizes and shapes, twisted gold effects, and pendants from half an inch to fully two inches in length.

* * *

A striking belt buckle is made of an enameled spray of spirea, the center of which glows with the soft iridescence of opals. The braid that forms the belt is curiously shaded to harmonize with the tones of the flower. The same ideas are carried out in La Vallieres. The pendant is slightly oblong with rounded corners, the central *motif* being the glass beetle. This is hung upon a narrow braid, rather coarse in grain, which is further ornamented by two small sections corresponding with the

pendant in design. They are smart, Oriental and most unique.

* * *

Something novel in belt buckles has just appeared. It is of chased silver and consists of the clasp for the front and a large section for the back. The former is not unusual in shape, but the latter is so curved that it fits snugly into the lines of the waist. More than this, it is so made that an elastic band is inserted underneath the leather and is joined to the front sections of the buckle. Thus the belt is adjustable to a waist of any size, and the peculiar curve of the leather strap gives a most graceful and charming line to the figure. These attractive belts may be had in all colors of hand-tooled leather, matching costumes of all the newest shades. Other new silver buckles are vermicelli hand-chased, set with a single large stone, or the monogram effect in a new style of lettering.

ELSIE BEE.

Jewelry, Clocks, Watches, Silverware and Kindred Lines Exported from New York.

WASHINGTON, D. C., April 15.—The following were the exports of jewelry, silverware, optical goods, clocks, watches and kindred lines from the Port of New York for the week just ended:

Bremen: 3 cases plated ware, \$250; 2 cases jewelry, \$125; 2 cases watches, \$2,553.

Buenos Ayres: 8 cases plated ware, \$1,390; 1 case silverware, \$460; 1 case jewelry, \$390; 1 case watches, \$264; 1 case plated ware, \$280; 1 case watches, \$1,284; 21 cases clocks, \$1,501; 2 cases optical goods, \$1,426.

Calcutta: 17 cases clocks, \$375.

Callao: 2 cases watches, \$434.

Christiania: 7 cases clocks, \$360.

Colon: 1 case clocks, \$172; 23 cases clocks, \$282.

Copenhagen: 5 cases clocks, \$105.

Geneva: 2 cases optical machinery, \$196.

Glasgow: 22 cases clocks, \$192; 1 case plated ware, \$100; 80 cases clocks, \$2,175.

Hamburg: 31 cases clocks, \$1,730; 4 cases optical goods, \$1,044.

Havana: 25 cases clocks, \$568; 1 case watches, \$280; 2 cases scopes and views, \$137; 2 cases watches, \$119; 9 cases optical goods, \$3,523; 19 cases plated ware, \$2,317; 31 cases clocks, \$361; 3 cases clocks, \$325; 15 cases optical goods, \$1,665; 4 cases jewelry, \$2,700; 1 case silverware, \$100.

Kingston: 1 case optical goods, \$107.

Lisbon: 18 cases clocks, \$257.

Liverpool: 72 cases clocks, \$1,100; 1 case jewelry, \$600; 1 case silverware, \$200; 2 cases clocks, \$125; 1 case watches, \$286; 1 case silverware, \$212; 5 cases clocks, \$340.

London: 2 cases optical goods, \$108; 1 case jewelry, \$280.

Manchester: 50 cases clocks, \$549.

Manila: 2 cases silverware, \$346; 1 case optical goods, \$100.

Melbourne: 11 cases plated ware, \$902; 6 cases stereoscopic goods, \$1,200; 3 cases optical goods, \$100; 74 cases clocks, \$1,459.

Montevideo: 8 cases plated ware, \$576.

Puerto Hadryn: 1 case watches, \$125.

Rio de Janeiro: 48 cases watches, \$246; 218 cases clocks, \$4,225; 2 cases optical goods, \$270.

Santos: 2 cases watches, \$448.

Southampton: 10 cases watches, \$1,669; 25 cases watches, \$3,811; 2 cases stereoscopes, \$368; 1 case optical goods, \$202.

Trinidad: 8 cases clocks, \$150.

Valparaiso: 19 cases plated ware, \$2,574.

Vera Cruz: 2 cases plated ware, \$133; 128 cases clocks, \$2,159.

David S. C. Brimer will make his future headquarters in Hurt's store, at Page, N. Dak.

Peter Muller, Perham, Minn., will build a modern building in the place of the block which was burned some time ago.

REGISTERED



TRADE-MARK

RINGS

REGISTERED



TRADE-MARK

RINGS are always in demand, and are always salable, provided you have the right kind to sell. We have—

RINGS of every description: signet rings, diamond rings, fancy rings, rings of every style and combination of stones.

RINGS that satisfy the most critical and appeal to every taste and fancy.

RINGS You can sell. *Write us or wire us any time. We are always ready for your order.*

HAYDEN W. WHEELER & CO., Importers

AMSTERDAM, 2 Tulp Straat

2 Maiden Lane, NEW YORK, N. Y.
Phone, 7365 Cortlandt

LONDON, 50 Holborn Viaduct

EDUARD VAN DAM

CUTTER OF

DIAMONDS

CUTTING SHOPS:

ANTWERP

41 Rue de la Province (Sud.)

CABLE ADDRESS, MADNAV

NEW YORK437-439 Fifth Ave.
Cor. 39th St. Knabe Bldg.TELEPHONE, 5879 38TH ST.
CABLE ADDRESS, DEVRIVAN**AMSTERDAM**

55 Ruysdaelstraat

CABLE ADDRESS, MADNAV

LONDON OFFICE, 22 Holborn Viaduct

AMSTERDAM

2 Tulpstraat

LONDON

40 Holborn Viaduct

OPPENHEIMER BROS. & VEITH.

CUTTERS OF DIAMONDS.

Cutting Works
43-45-47 John StreetNEW YORK
65 Nassau Street

RUDOLPH NOEL

PHILIP NOEL

RUDOLPH NOEL & CO.**IMPORTERS AND CUTTERS OF DIAMONDS**

2 Tulp Straat, AMSTERDAM

37-39 Maiden Lane, NEW YORK

Schedules in the Bankruptcy of the Shourds, Adcock, Teufel Co., Chicago Forty Per Cent. Settlement Offered.

Chicago, April 16.—The American Trust & Savings Bank, receiver for the Shourds, Adcock, Teufel Co., was appointed trustee of the estate last Tuesday. The schedules in bankruptcy of the corporation show the creditors to be as follows:

From \$50 to \$100—Chas. H. Allen & Co., R. Blackinton & Co., Wolf & Co., Illinois Watch Co., Ross, Saltman & Anderson, Benedict & Warner, Goodfriend Bros.

From \$100 to \$150—Chas. Adler's Sons, Allsopp Bros., Crane & Theurer, A. T. Cross, Dennison Mfg. Co., Wallach & Davidsen, E. G. Webster & Son Co., Julius Wodiska, August Rassweiler, Rettig, Hess & Madsen, Wm. L. Sexton & Co., Geo. W. Shiebler & Co.

From \$150 to \$200—American Morocco Case Co., Bigalke & Eckert Co., Hipp, Didsheim & Bro., Winslow, Krause & Co., Hirsch & Oppenheimer, Kaffeman, Rothschild & Co., Wm. Kinscherf Co., Martin-Copeland Co., M. A. Mead & Co., J. Milhennig, Reeves & Browne Co., Schrader, Wittstein Co., Simons, Bro. & Co.

From \$200 to \$300—Waterbury Clock Co., Hayden W. Wheeler Co., David C. Dodd & Co., Ford & Carpenter, M. Guggenheim, Walter E. Hayward, A. J. Hedges & Co., J. D. Williams & Co., Keller Jewelry Mfg. Co., Larter & Sons, Sansbury & Nellis, Bassett Jewelry Co., Hoyt, Obrig & Geiger Co., Wm. Matschke, Thornton Bros.

From \$300 to \$400—Whiting & Davis, Hemz Bros., Allsopp & Allsopp, Crossman Co., Gorham Co., Hirsch & Flashner, A. Joramson & Sons, Osmun, Parker Mfg. Co., C. Ray Randall & Co., Weigle & Rose.

From \$400 to \$500—Benj. Allen & Co., A. Hirsch & Co., Towle Mfg. Co., W. & S. Blackinton Co., Dominick & Haff, Grimm & Judae, Wm. S. Hedges & Co.

The largest creditors are: G. Amney, \$1,254; American Watch Case Co., \$516; Alling & Co., \$568; Bippart, Griscom & Osborn Co., \$775; Carter, Howe & Co., \$1,865; Codding & Heilbron Co., \$506; Eichberg & Co., \$2,286; Fera & Kadison, \$1,394; Unger Bros., \$726; R. Wallace & Sons Mfg. Co., \$552; Whiting Mfg. Co., \$1,594; A. Wittnauer & Co., \$1,210; Krementz & Co., \$944; L. W. Levy & Co., \$795; Luthy & Hine, \$515; Mandeville, Carrow & Crane, \$710; Riker Bros., \$2,051; M. A. Sawyer & Co., \$529; Stein & Ellbogen Co., \$638; Strobel & Crane, \$579; David Ullman & Co., \$602.

To Messrs. Shourds, Adcock and Teufel there is due for back salaries \$2,554, \$2,291 and \$2,665 respectively. To the Hibernian Banking Association there is due \$12,000 for money loaned, secured by real estate owned by Teufel. There is due for rent \$4,593. As the premises are not yet vacated, the rent is piling up at the rate of \$1,667 a month. The total liabilities, including the \$12,000 owing the Hibernian Banking Association, are \$61,445.

The accounts receivable on paper amount to \$4,812, and the appraised stock is valued at \$46,000.

CHICAGO, April 18.—The members of the Shourds, Adcock & Teufel Co. are offering

their creditors a settlement on the basis of 40 cents cash. As the creditors have already received 20 per cent of their claims, the total will amount to 60 cents, which is considered a very good offer. The corporation offers to pay the costs of administering the estate while in bankruptcy. The creditors will have no expense to bear.

M. L. R. Howald, Salem, O., Makes an Assignment.

PITTSBURG, Pa., April 15.—M. L. R. Howald, Salem, O., has made an assignment for the benefit of his creditors, and L. B. Harris, of Salem, has been named as the assignee. Howald's liabilities, it is reported here, total about \$5,800, and his assets are said to be worth \$3,000. There are five or six Pittsburg firms who are creditors, and several are said to have been caught for large amounts.

The report of the failure caused considerable comment here. Mr. Howald had been conducting an auction sale, which he concluded by filing the deed of assignment. The assignee, however, states that the auction was discontinued because it was not paying, and not with the intent to defraud creditors. Howald, it is said, does not possess any real estate, his property being personal. The deed of assignment was filed in the Probate Court at Salem last week. The following appraisers have been named: H. W. Kesselmire, J. K. Pickett and Clarence Smith.

Death of Henry O. Dudley.

MANCHESTER, N. H., April 16.—Henry O. Dudley, a well-known resident of East Manchester, who died at his home, 398 Belmont St., April 11, as a result of an attack of acute indigestion, had long been a member of the jewelry trade, and had been in business here for many years.

Deceased, who was 73 years old, was born in Barton, Vt., and learned the jewelry business many years ago. He was a veteran of the Civil War, having served in Company E, 15th Regt. Vermont Volunteers, and after the war was a member of Captain Joseph Freschl Post, G.A.R. He conducted business in St. Johnsbury until about 17 years ago, when he moved to Manchester, since which time he was engaged as a jeweler here. Mr. Dudley is survived by a son, S. A. Dudley, and two daughters, Mrs. J. F. Adams, of East Barnett, Vt., and Mrs. Calvin Shaw, of Bellows Falls, Vt.

Involuntary Bankruptcy Petition Filed Against Aaron Mendelsohn, Boston, After He Had Assigned.

BOSTON, Mass., April 18.—Aaron Mendelsohn, wholesale and retail jeweler, doing business under the firm names of A. Mendelsohn & Co. and Mendelsohn Bros., made an assignment Thursday of his assets to Leon R. Eyges, his attorney. The following day an involuntary petition in bankruptcy was filed against him at the instance of three creditors whose claims amount to \$1,652.

Mr. Mendelsohn returned but a short time ago from a trip to Europe. Last year he was associated with William E. Woodman in an auction sale subsequent to the failure of the W. E. Woodman Co.

His place of business is in the Jewelers' building, room 43.

Members of the New England Watchmakers' Club Hold Enjoyable Annual Banquet—Exhibition Opened.

BOSTON, Mass., April 16.—The annual banquet of the New England Watchmakers' Club, held to-night at the American House in this city, was a noteworthy gathering of representative men in the trade. It brought together a large assemblage of expert workmen in the watchmaking and repairing industry, and among the guests and speakers were Treasurer Royal Robbins, of the Waltham Watch Co., and several heads of departments and "missionaries" of the company; James S. Blake, Carl D. Smith, Frank S. Sherry, Edward E. Hardy, William May, and others of the Boston wholesale watch, watch materials and jewelry trade. There were about 150 members of the club and their guests at the dinner, which was presided over by President F. J. Whilton.

When the banquet had been served there were a number of speeches, among those called upon by the president being Mr. Robbins, Mr. Blake, Mr. Smith, Supt. E. A. Marsh of the Waltham factory, J. W. Burckes, Olaf Olson, H. E. Duncan, F. W. Ruggles and others. The remarks of Mr. Robbins relative to the financial depression, in which, while fully recognizing its present effect, he expressed confidence in a gradual and steady return to prosperity, were listened to with especial interest because of the fact that Mr. Robbins is widely known in this State as an expert on economic questions.

The club raised by collection upward of \$33 for the Chelsea fire sufferers.

During the week as an adjunct of the meeting and banquet there was an exhibition at the club headquarters, 17 Bromfield St., of watch tools and machinery. Among those participating were the American Watch Tool Co., showing the Webster-Whitcomb lathe outfit; the Rivett Lathe Mfg. Co., showing a machine for grinding chucks, also watchmakers' lathes and attachments, and extra large machine lathes; Charles May & Son, who displayed a show case filled with watchmakers' tools and novelties for repairers; the Holzer-Cabot Co., motor lathes; Frank Randall, staking tools, roller removers, screwdrivers and gauges; E. A. Cowan, tools; and the Carborundum Co.

The American Watch Tool Co. presented a lathe outfit to the club.

Death of Emil H. Koerner.

ST. PAUL, Minn., April 15.—Emil H. Koerner, vice-president of the E. A. Brown Co., died at his home, yesterday, of a complication of diseases. Mr. Koerner was a diamond expert for the company, and had been with the firm for 18 years.

He was a member of the various Masonic bodies, including the Blue Lodge, Chapter, Commandery, Shrine, and also the Scottish Rite bodies. The funeral was held under the auspices of the Knights Templar.

A movement has been inaugurated toward the purchase of a clock for the tower of the Model School building in Coudersport, Pa. The cost will be about \$1,200.

Cameos=Scarabs=Carbuncles

Notwithstanding the difficulty generally experienced at present in supplying the sudden demand for these goods, we have succeeded, thanks to our firmly established connections with the stone centers of Europe, in making arrangements for the uninterrupted supply of them and are, therefore, fully prepared to fill all orders for these articles with the least delay.

CAMEOS

Onyx, Pink and Brown Shell, and Coral

SCARABS and CARBUNCLES

Red and Brown Sard, Bloodstone, Moss Agate, Green Agate, New Zealand and Chinese Jade, Amazonite, Tiger Eye, Coral Japanese and Italian, and

TURQUOISE MATRIX

L. Heller & Son

Importers of Precious and Imitation Stones
68 NASSAU STREET, NEW YORK

PARIS
39 Rue de Chateaudun

PROVIDENCE
212 Union Street

IDAR
14 Hauptstrasse

ORDER

DIAMONDS

ON MEMORANDUM FROM

ALFRED H. SMITH & CO.

London,
6 Holborn Viaduct.

170 BROADWAY, NEW YORK.
Corner Maiden Lane.
Also 475 FIFTH AVENUE.

Chicago,
103 State Street.

TURQUOISE

Matrix-Turquoise
BEST THE WORLD PRODUCES

Exquisite Color
and Markings



No. 222

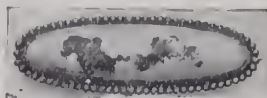

No. 316

SEND FOR CATALOG

Showing 133 different sizes and shapes
of MATRIX-TURQUOISE STONES
ready for Mounting.

**The Arizona
Turquoise Mines Co. Inc.**

Cutting Works and Sales Office:

171 BROADWAY, NEW YORK
Telephone 5728 Cortlandt

Tel. 4457 } Cort.
4458 }

JOHN M. RICHARD 2 MAIDEN LANE
Room 302, NEW YORK

American Pearls and Baroques

MATCHED PAIRS FOR EARRINGS

The Largest and Finest Assortment in the
Market, Mounted and Unmounted.

GEMS AND PRECIOUS STONES

Cloth, Postpaid, \$1.00

Published by

The Jewelers' Circular Pub. Co., 11 John St., N. Y.

Attleboro Manufacturing Jewelers Look for a Resumption of Good Business After Presidential Candidates Are Named.

ATTLEBORO, Mass., April 18.—"Just how soon can we expect to see an improvement in the jewelry business?" was a question addressed the past few days to some of the more prominent men in the trade in this town. A consensus of their answers is fairly encouraging.

Some improvement is looked for early in June, and all seem to feel that as soon as the Republican National Convention has been held, and the candidate and policy of the dominant party settled, business will take a decided burst of new life. The improvement in early June is laid to the fact that from now till May 1 is the period for the traveling salesmen to be going out on the road, with their samples for the so-called Fall trade. It is not believed that these men will meet a wholly unresponsive market. Even if their sales run rather less than in good years, they can hardly fail to introduce some goods to the jobbers and retailers that the latter will feel obliged to buy in self defense.

A few of the traveling men who have been out for short trips to feel the pulse of business, report an unusual state of affairs in many retail and department stores. They found old goods, not shop-worn, but decidedly out of style, raked out of oblivion and offered to the public as if new, in an effort to save further investment in new stock. One of the most striking examples of this was found by a manufacturer who is his own head salesman. In one city he found a customer who had bought of the house for a generation, offering to the public a quantity of bracelets made when the manufacturer's father was alive and head of the firm, long, long ago. As a matter of fact, these particular antiquities had rather "caught on," and were selling well.

A temporary burst of activity, if nothing more, is looked for, and THE CIRCULAR-WEEKLY correspondent found some optimistic enough to think the sales will be very large. Buyers with keen memories are going to find in the samples offered them in the next few weeks a number that will strongly remind them of the January trips. The lines gotten out then were so good that in many cases they will be offered right over again, with a few changes and improvements to keep them from being out of date.

The manufacturers also feel sure that directly after the Republican National Convention a real boom will come. Those who say this do so regardless of their own political preferences. They believe that when it is definitely settled what the policy and who the candidate of the leading party will be, all will accept the situation, and turn their attention exclusively to booming business.

Meantime the direct effect of the condition of affairs is a general curtailment in the Attleboro shops, the public organization of a society of manufacturers and public men to help the unemployed, and the building of additional highways as an indirect means of dispensing practical aid. In most of the factories preference is given to resident help in order to hold the best of

the shops' crews together till good times come again. In several the present policy is not to lay off even a single permanent hand, but to give all one to five days a week, according to the state of trade with each firm, thus dividing up the wages and preventing real hardship.

The manufacturers have sounded the situation carefully and are led to believe that the women of the country will continue to wear elbow sleeves, at least this one more Summer. That spells continued demand for bracelets, which are now made by nearly all the concerns and form an important staple.

Paris Pearl Market.

PARIS, April 16.—Although the month of March brought no large transactions among the pearl dealers in this city, the general trade was very much better than at the beginning of the year, and the merchants seem to display a better feeling toward the future. There are continual demands for pearl necklaces from all parts of Europe, especially from Germany and Italy. The stocks altogether have shown very poor assortments and the goods wanted in many cases could not be procured. A satisfactory feature of the demand that has been manifested lies in the fact that it came not from speculators, but their private customers. Several South American shippers were also in the market for pearls and diamonds, and this contributes somewhat to the better feeling. Medium qualities are asked for continually, and for these full prices are obtained.

The death of Oscar S. Eisenmann, which as noted in THE CIRCULAR-WEEKLY, occurred March 29, in this city, was a distinct shock to his friends here, and was the cause of universal regret in the gem trade. How much his brother merchants appreciated him and his many fine qualities was manifest during the funeral, by the enormous number of friends and business associates who assembled to participate in the last rites. G. K.

Prices of Pearl Shell May be Higher.

WASHINGTON, D. C., April 15.—According to recent dispatches, it is expected that the price of pearl shells will be higher this year than it has been for some time past, owing to the fact mentioned in a recent issue of THE CIRCULAR-WEEKLY that the Ceylon banks have been closed for inspection.

As is well known, not only the pearl but the shell of the pearl oyster is largely used in commerce for the manufacture of pen-knives, opera glasses, and numbers of other items, and for an unlimited period the best shells have always come from Ceylon. The price of pearl shells in recent years has varied from \$26 to \$35 per ton at the Continental ports. While the law of supply and demand has always been the chief factor in determining the price, the quality of the shell and the mode of packing employed have also had their influence.

It is sometimes impossible, even when a large fishery is made, to secure large quantities of the shells because of irregularities of shape, and the prevalence of a worm which eats into the shell. Beside the ordinary shell there is what is known as the

window pane shell, and this is a product of a Government fishery, the annual yield only amounting to something below 200 tons. The sizes are between five and seven inches, and the prices vary from \$70 to \$90 per ton at the Continental ports.

Death of Oscar F. Sturmer.

BALTIMORE, Md., April 18.—Oscar F. Sturmer, a jeweler and optician of Easton, Md., committed suicide in a most sensational manner yesterday afternoon by jumping from a train while crossing the Susquehanna river at Havre de Grace, Md. He was in the smoker of the Pennsylvania Express when the train pulled out from Havre de Grace station, and as the train started he was seen to go out on the rear platform. When the train was about in the middle of the bridge Mr. Sturmer was seen to throw up his hands and deliberately jump into the river, 95 feet below.

Capt. George Lay, who was in a launch with two companions, saw the man hit the water near the bridge, and went to his assistance. They had trouble with their engine and could not stop where the man had fallen, but passed close enough to hold out an oar to him, but he made no effort to catch it. When the boat was finally put about the body had disappeared and could not be found. It was later recovered by dragging the river. In the pockets of the drowned man were some business cards, a certificate of membership in the Emergency Hospital at Easton, and some money.

Mr. Sturmer had left Easton, Sunday night, for Baltimore, in the best of health, to attend the races at Benning. His suicide was a severe shock to his friends in Easton, where he was well known socially, as well as in business circles. He was born in Pittsburg 37 years ago. He went to Easton about 14 years ago from Danville, Va., and purchased the jewelry business of E. P. Langston, which he had since conducted. He was a regular churchgoer, and was a member of Knights of Pythias and the Masonic fraternity.

Importations at the Port of New York.

Weeks Ended April 13, 1907, and April 11, 1908.		
	1907.	1908.
China, Glass and Earthen Ware:	1907.	1908.
China	\$73,397	\$53,119
Earthen ware	8,230	146,061
Glass ware	18,637	18,729
Optical glass	708	1,096
Instruments:		
Musical	18,342	11,457
Optical	9,417	9,310
Philosophical	511	4,879
Jewelry, etc.:		
Jewelry	6,585	6,863
Precious stones	410,097	145,997
Watches	43,951	14,896
Metals, etc.:		
Bronzes	1,045	3,671
Cutlery	31,821	23,608
Dutch metal	2,092	2,679
Platina	1,220	11,129
Plated ware		
Silverware	1,127	685
Miscellaneous:		
Amber	1,174	4,821
Alabaster ornaments	29	
Beads	2,494	958
Clocks	6,242	2,873
Fans	316	786
Fancy goods	7,970	8,651
Ivory	7,891	
Ivory, manufactures of	576	242
Marble, manufactures of	37,513	5,876
Statuary	3,975	1,760



WE wish to inform the trade that we are now located in THE NEW SILVERSMITHS BUILDING, 15-17-19 MAIDEN LANE, where we will have, at all times, a complete stock of

Precious and Semi-Precious Stones

Our cutting works, which are located at the same address, are more complete than ever with modern appliances, thereby permitting our skilled workmen to do cutting, polishing and repairing of the finest gems in the best workmanlike manner.

Thanking you for past favors, and trusting for a continuance of the same,

Respectfully yours,

HIMALAYA MINING COMPANY

MINERS AND CUTTERS OF

PRECIOUS AND SEMI-PRECIOUS STONES

NEW YORK

LONDON :: PARIS :: OBERSTEIN :: PROVIDENCE

Telephones: ⁸⁸⁷⁰ }
⁸⁸⁷¹ } Cortlandt
⁸⁸⁷² }

Connecting all Departments

Retail Jewelers of Oklahoma Begin Annual Session at Oklahoma City.

OKLAHOMA CITY, Okla., April 21.—Jewelers from various sections of the State are in this city this morning to attend the annual meeting of the Oklahoma Retail Jewelers' Association, which convenes here in the Chamber of Commerce building. The session which has just begun is considered to be most important to the trade, and the officers of the association, particularly F. C. Boasen, the secretary, and Joseph Mazer, the president, have been making strong efforts to have the meeting mark an epoch in the history of the organization and also to decidedly increase its membership. The members of the trade in this State have been made acquainted with the objects of the association and a programme of the meeting, and it is believed that the attendance will increase as time goes on.

This morning the session will be taken up with the reading of the minutes of the previous meeting, applications for membership, and an address by H. A. Bump, entitled "A Few Business Pointers." The schedule for the afternoon session, which begins at 1:30 p. m., includes the address by the president on the subject, "What the Association Has Done in the Past Year," to be followed by a discussion of the Vreeland Watch Case Marking bill now in Congress and a vote on the proposition of endorsing it.

The session which begins at 7:30 p. m. this evening, according to the programme, will be devoted to a lecture by Charles F. Higgenbotham, of the South Bend Watch Co., on "Errors of Escapement and How to Correct Them," which lecture is to be illustrated with charts and a large and complete model of a watch movement.

To-morrow (Wednesday) three sessions will be held, the morning session to be devoted to new business, the reports of committees and a discussion on the following question: "What Minimum Selling Price on Low-Grade Movements Shall We Recommend to Manufacturers?" In the afternoon the members will discuss the question of electing a delegate to the national convention and a programme for the coming year. Following this the officers will be elected and installed.

To-morrow evening will be devoted to a banquet and smoker.

The Oklahoma State Optical Association, to which also a number of members of the Retail Jewelers' Association belong, will meet here April 23-24.

N. H. Hessey, Jeweler and Pawnbroker, of Austin, Tex., Commits Suicide by Hanging.

AUSTIN, Tex., April 17.—N. H. Hessey, a well-known jeweler and pawnbroker, of this city, who has long been connected with the trade here, committed suicide some time yesterday, his body having been found hanging in his barn a little after 8 o'clock in the morning. There were no papers in his clothes, nor did he leave any message, so there was nothing to show that the act was premeditated.

Mr. Hessey, who is 38 years old, is survived by a widow and a child. He was a man of jovial disposition, was well liked in

business and social circles, and had a wide circle of friends, to all of whom his death was a great shock.

Judge Refuses to Release Solomon Urbach from Jail, Saying He is a Fraudulent Bankrupt.

Argument for the release of Solomon Urbach, who has been in custody in the Ludlow St. Jail, New York, since last October on a charge of contempt of court in not turning over to his trustee in bankruptcy about \$40,000 in diamonds, was heard before Judge Holt in the United States District Court, April 13. In his memorandum handed down April 11 Judge Holt says:

I have gone over the facts in this case, they are perfectly conclusive. The bankrupt's statement of property, the conversion of it all into cash, the purchase of diamonds on credit, his ignorance of the diamond business, his night trip to Baltimore, the preposterous story of the robbery, his refusal to testify as to his arrest, all the circumstances of the case, and his general style of testifying, show that he is a fraudulent bankrupt, who has concealed his property. I am sorry for his wife and children, but the one to blame for their plight is the husband and father. Let him produce the property or stay in jail until he does. I cannot release such a man until he makes restitution to his creditors.

Solomon Urbach was formerly a diamond dealer at 19 Maiden Lane, New York. A petition in bankruptcy was filed against him in September, 1906.

Readers of THE CIRCULAR-WEEKLY will recall that Urbach alleged that he took the midnight train from New York on Sept. 10, 1906, for Baltimore, Md., with diamonds valued at about \$40,000 in his possession, and that some time after midnight they were stolen from his berth in the sleeping car. He claimed that he had put his waistcoat with the wallet containing the diamonds under his head, and upon his arrival in Baltimore he found that the diamonds had disappeared.

Creditors immediately brought bankruptcy proceedings, and after examining Urbach obtained an order from the referee directing the bankrupt to restore the missing assets.

Reappraisements of Watch Jewels and Watch Cases.

Among the reappraisements of merchandise made last week by the Board of United States General Appraisers were the following:

WATCH JEWELS.—From Oser & Co., Bienne, March 6, 1908, entered at New York (File No. 48458, Invoice No. 22928); findings of Lunt, G. A.: Sapphire balances oliv., entered at 18.50 francs per 100; ruby upper center, entered at 28.50 francs per 100; garnet roller jewels, entered at 3.30 francs per 100; sapphire pins, entered at 9.75 francs per 100; garnet pins, entered at 1 franc per 100; no advance.

WATCH CASES.—From Gutman & Co., Chaux de Fonds, exported Oct. 22, 1907, entered at New York (File No. 48539, Invoice No. 26385); findings of Fischer, G. A.: No. 31, 24 sav. arg. 935-000, entered at 21, advanced to 22 francs per half dozen; No. 71, 18 do., entered at 27 francs per dozen; no advance; discount, 3 per cent; add case.

C. G. Swanson, Luverne, Minn., has moved his stock to Parker, S. Dak., where he will engage in business.

J. W. Johnson, secretary of the Arkansas Retail Jewelers' Association, moved to Hope, Ark., last week, where he will continue his business as heretofore.

Chances for American Manufacturing Jewelers to Develop Trade With Brazil.

WASHINGTON, D. C., April 18.—Consul-General Anderson, at Rio de Janeiro, says that manufacturing jewelers of the United States seem to have an opportunity to develop considerable trade in Brazil, a field which he states is at present served all but exclusively by German and French houses. Mr. Anderson states as follows:

One or two American houses have made an effort to get into the trade here, and seem to have had very fair success. In 1906, the last year for which figures are available, Brazil imported about \$250,000 worth of gold jewelry and \$193,000 of silver jewelry, these amounts being in addition to items in which copper was the chief constituent part, plated ware of different sorts other than jewelry. Of the imports of gold jewelry and jewelry classed as such, Germany sent about 58 per cent., France about 35 per cent. In silver jewelry Germany had about two-thirds of the trade, France about one-fourth, with the small balance scattered.

During 1907 several representatives of American houses came into the trade and reported that they had considerable success, especially in the line of cheap jewelry. Later figures, therefore, are likely to show considerable returns from the United States, although the bulk of the trade is still where it has been for a good many years, as indicated.

It is difficult to give a definite idea of the customs and other situation, for the quality of goods varies so much that generalizations are likely to mislead. No particular marks are required of imported goods, and there is no reason why American goods cannot be sold as well as any other, if American manufacturers can meet the competition. Styles are in general practically the same as those obtaining in the less expensive goods in the United States. There is a natural leaning in all South America in such matters to French styles and ideas.

Whether it can be said that the trade will recognize quality in goods depends altogether upon whether or not the goods are properly presented. There are comparatively few lines of filled goods in vogue here at present, but probably this is a matter of price more than anything else. The goods ought to be presented in no other way than by a direct representative. A manufacturer's agent may sometimes be in a position to get in touch with the trade; but work through cataloguing or even through export commission houses will likely be thrown away.

Credits as a rule are liberal. Terms vary considerably, but six months' time with interest from the date of the invoice is reported as a common provision. It is unsafe to quote prices now prevailing, in view of the wide variation in the quality of goods.

The consul-general forwards a list of Rio de Janeiro business firms for manufacturers wishing to secure further details of the trade or to attempt to secure agents or business by correspondence. These names may be secured from the Bureau of Manufactures, Washington, D. C.

Chester Billings & Son

1840

Successors to
Kandel, Barmore & Billings

1908

Importers of Diamonds
Other Precious Stones, and
Pearls, Diamond Jewelry

1840, Kandel & Barmore; 1866, Kandel, Barmore & Co.; 1880, Kandel, Barmore & Billings; 1897, Chester Billings & Son

New York, 58 Nassau Street, 29 Maiden Lane
London: 22 Holborn Viaduct, E. C. Paris: 53 Rue de Chateaudun
Amsterdam: 2 Culp Straat

GEORGE H. HODENPYL.

WALTER N. WALKER.

HODENPYL & WALKER

IMPORTERS OF

DIAMONDS

OTHER PRECIOUS STONES
AND PEARLSMANUFACTURERS OF
FINE DIAMOND JEWELRY

373 FIFTH AVENUE,

NEW YORK

Corner 35th Street

Telephone, 5093 Madison Square

EISENMANN BROS.

IMPORTERS OF

Pearls and Precious Stones

452 Fifth Avenue, New York
cor. 40th St., Knox Building

3 Rue St. Georges, Paris.

ARTHUR REICHMAN

DEALER IN

AMERICAN BAROQUE PEARLS

65 Nassau St.

New York

William G. Morstrom & Co.

DIAMOND IMPORTERS and MANUFACTURING JEWELERS

Memorandum Packages of Loose or Mounted Stones on request. We solicit Special Order Work.

78-80 STATE STREET

CHICAGO, ILL.

H. F. BARROWS COMPANY

MAKERS OF

Rolled Plated Chains

FACTORY:

NORTH ATTLEBORO, MASS.



AFTER MAY 1st

Our New York Office will
be Room 1705-17th floor
SILVERSMITHS BUILDING
15-17-19 Maiden Lane.

TELEPHONE CONNECTION

New Haven Jeweler Causes Arrest at Cincinnati of Man Believed to Have Robbed Many Firms.

CINCINNATI, O., April 18.—A man, believed to be "the thief with the automobile clock," who robbed a number of jewelers of New England after becoming acquainted with them by leaving an automobile clock to be repaired, was arrested in front of Heruan Lange's jewelry store, 125 Vine St., to-day. The complainant against the man is Abraham Silverthau, of New Haven, Conn., who came on for the purpose of catching him after he had been warned that the man was in the city by Mr Lange's watchmaker. When searched, a diamond, which Mr. Silverthau claims to be one of three stolen from him, was found. It was said that the man has admitted his identity and will go back to New Haven to answer the charge.

As told in THE CIRCULAR-WEEKLY, March 25, Mr. Silverthau lost three pairs of diamond ear drops by the tricks of the "automobile clock" thief, and it is claimed that among the other victims of the same man were: J. D. Kingsberg, Springfield, Mass.; L. Simon, Brooklyn, N. Y.; Aaron Ball, Troy, N. Y.

B. Von Wahlde, employed by Mr. Lange as watchmaker, read the account in THE CIRCULAR-WEEKLY, and learning that a man who answered the description was in Cincinnati, notified Mr. Silverthau. The latter arrived here at 2:30 p. m. and by three o'clock had caused the arrest of the suspect. Mr. Silverthau said the man admitted his identity when accosted.

Henry Fogler Loses Suit for Damages Against Creditors Who Filed Bankruptcy Petition Against Him.

On Wednesday of last week, the case of Henry Fogler against R. L. & M. Friedlander, Harris & Schuster, and Sigmund Kohn & Co., came up in the Supreme Court, Part II., in New York City, before Judge Newburger and a jury and the case was dismissed with costs. The action was brought by Mr. Fogler to recover \$50,000 damages for alleged harm done him by the filing of a bankruptcy petition against him in the United States District Court, in April, 1906, by the defendants in this action. The petition in question against the plaintiff alleged that he was insolvent, and he had transferred or concealed certain property, and that he had made preferred payments to certain creditors. Judge Holt, on April 16, 1906, signed an order dismissing the petition against Fogler, he having settled with creditors for 100 cents on the dollar.

In his complaint the plaintiff alleged that his credit had been impaired by the bankruptcy petition, and that he was continually obliged to explain to customers his true financial condition, and was thus caused much annoyance, and that he was unable to attend to his business for some time. He asked \$50,000 for damages alleged to have been sustained by him.

When the case came up before Judge Newburger, Wednesday morning, he did not allow it to go to the jury on the ground that there had been no adjudication in bankruptcy in the United States District

Court, and that therefore there was no ground for the complaint. The contention of the defendants was that since the complainant had paid 100 cents on the dollar, and the petition in bankruptcy had never been tried out in the United States District Court, that the plaintiff could not maintain an action.

A judgment for \$250,000 has been entered against the complainant, who was represented by Weil & Weil. The defendants were represented by Messrs. Lindsay & Kalish, of the firm of Lindsay, Kalish & Palmer.

Cincinnati Retail Jewelers' Association Repudiates Attack Made by Its Official Organ Upon Officers of the A. N. R. J. A.

CINCINNATI, April 15.—As a result of the meeting of the Cincinnati Retail Jewelers' Association, called April 10, when President Mack A. Hurlbut and Secretary I. M. Radabaugh, of the American National Retail Jewelers' Association, were in Cincinnati in conference with the local association in regard to certain articles published in the April issue of a local paper, attacking the officers of the National Association, another meeting of the local association was called yesterday, when the following resolutions were adopted:

We, the Cincinnati Retail Jewelers' Association, in convention assembled, do hereby express our regret that articles have been published by the Association Jeweler, and our official organ, the Retail Jewelers' Journal, derogatory to the officers of the National Retail Jewelers' Association, believing that they were caused by a misapprehension of their true motives. We are convinced after much investigation that they stand for the best interests of the retail jeweler and the national association at large, and hereby commend them for their untiring and faithful efforts. Be it further

Resolved, That a copy of these resolutions be sent to the National Executive Committee and to the Association Jeweler, with a request that they publish them, and to each of the leading trade journals and to the Retail Jewelers' Journal for publication.

The above resolution was drawn by the undersigned and recommended by them to the Cincinnati Retail Jewelers' Association. (Signed) J. R. STEBBINS, President Ohio Retail Jewelers' Association; L. C. EISENSMITH, President Kentucky Retail Jewelers' Association; C. Z. ROWE, President Indiana Retail Jewelers' Association.

Jewelers' Gold Bars Withdrawn and Exchanged at New York.

Week Ended April 18, 1908.

The U. S. Assay Office reports:
Gold bars exchanged for gold coin...\$1,170,723.05
Gold bars paid depositors..... 42,591.48

Total\$1,213,314.53

Of this the gold bars exchanged for gold coin are reported as follows:

April 13.....	\$45,447.49
" 14.....	58,056.01
" 15.....	20,400.78
" 17.....	1,016,439.96
" 16.....	20,400.78
" 18.....	19,978.03

Total\$1,170,723.05

R. L. McGhee and J. F. Bruns contemplate forming a stock company in Greenville, S. C., where they will open a jewelry store in the near future. The business will be conducted in the store now occupied by Mr. Bruns on Main St. The quarters will be remodeled and new fixtures installed.

Circular-Weekly's State Stamping Bill Signed by Gov. Fort of New Jersey.

NEWARK, N. J., April 15.—The jewelry trade of this city was pleased to learn that Governor Fort had, Monday, signed THE JEWELERS' CIRCULAR-WEEKLY State Stamping Law, which was recently passed by the legislature, and it is expected that the act will do a great deal toward eliminating the sale of spurious and falsely marked jewelry in this State.

The bill, the text of which was published in THE CIRCULAR-WEEKLY of March 11, is drawn to conform exactly with the National Stamping Law which went into effect June 13 last, except that it applies to the making and selling of articles of gold and silver falsely marked as to quality instead of to the shipment of the same in interstate commerce, as did the former; so between this and the National Law the fraudulent manufacturers or dealers will have a pretty hard time in the State of New Jersey and will probably give it a wide berth in the future.

The bill had been advocated by the Manufacturing Jewelers' Association of Newark, and in fact, had the support of the entire jewelry trade of the State, and while the enactment of the law was expected, as it passed with little or no legitimate opposition, the fact that it has gone on the statute books so quickly is the subject of congratulation by the trade here.

More About the Man Who Borrows Money on Cluster Jewelry.

COLUMBIA, Mo., April 16.—A man believed to be the same party that has been described in recent issues of THE CIRCULAR-WEEKLY, who succeeded in borrowing sums of money on cluster-set diamond jewelry, visited this town to-day and unloaded some jewelry on a tradesman here who was not a jeweler, as security for a large loan.

ALBANY, Ga., April 17.—The article in the recent issue of THE CIRCULAR-WEEKLY telling of the operation in Texas of a man and woman who made it a practice to borrow money on jewelry and a chronometer, was read with a good deal of interest here, as a pair of that description arrived at Albany, Ga., about two months ago and left with at least one man a parcel of jewelry as security for a loan of \$900. The jewelry, which was carefully sealed, is here yet and no one has come to redeem the articles which consist of cluster diamond goods and a repeater watch. While here the man said he was from Atlanta and represented a cigar house. He claimed he had to borrow the money quickly in order to buy or pay for some stock.

Market Price of Silver Bars.

The following are the quotations of silver bars in London and New York, as reported by Zimmermann & Forshay:

	London.	New York.
	1909 Basis.	
April 14.....	25 1-4d.	\$.56 ³ / ₄
" 15.....	25 3-8d.	.57
" 16.....	25 5-16d.	.56 ³ / ₄
" 17 (Holiday).....		
" 18.....	25 3-16d.	.56 ³ / ₄
" 20 (Holiday).....		

ADDISON W. WOODHULL, President.
FRANK K. HUFF, Vice-President.

GILBERT T. WOODHULL, Treasurer.
WILLIAM J. McQUILLIN, Secretary.

MOUNT & WOODHULL,

IMPORTERS OF

DIAMONDS,
OTHER PRECIOUS STONES,
PEARLS, ETC.

MAKERS OF

**FINE
DIAMOND
JEWELRY.**

26 Maiden Lane,
(Southwest Corner Nassau Street)

NEW YORK

EMERALDS, DIAMONDS AND PEARLS

BAGG & CO.
Successors to BAGG, PERINE & CO.
IMPORTERS
452 FIFTH AVENUE, at 40th Street
NEW YORK

CABLE ADDRESS: MILBAGG

TELEPHONE NUMBERS: 917-918 BRYANT

RUBIES AND SAPPHIRES

F. A. JEANNE

Cat's-Eyes

5 Square de l'Opera PARIS, FRANCE

Cable Address
"GEMFINDER"
Western Union Code

STERN BROS. & CO.,

CUTTERS OF

DIAMONDS,

CUTTING WORKS:
138-142 West 14th St., N. Y. 68 Nassau St.,
NEW YORK.

CHICAGO, LONDON.
103 State Street. 29 Ely Place.



THE LINE THAT SELLS, LEATHER FOBs

WITH EMBLEMS OF ANY SOCIETY,
Black or Tan Leather.

SPECIAL GRADE, with extra quality Gold-plated
Emblems, \$3.33 dozen.

REGULAR GRADE, with regular quality Gold-
plated Emblems, \$2.00 dozen.

LESS 10% FOR CASH,
On Single Cards or Half-dozen on Card.

Send your Order To-day.

THE CHAS. S. PURDY CO.
SOCIETY EMBLEMS
290 Westminster St. Providence, R. I.

Gems and Precious Stones

Cloth, Postpaid, \$1.00

Published by
The Jewelers' Circular Pub. Co.
11 John Street NEW YORK

JEWELRY IMPORTS AND EXPORTS.

A Review of Our Commerce in Clocks, Watches, Jewelry, Gems and Kindred Lines as Shown by the Government's Statistics.

WASHINGTON, D. C., April 19.—The following are the sources from which we imported jewelry, diamonds, watches and clocks, etc., during the fiscal year ending June 30, 1907:

AGATES, UNMANUFACTURED:	1907.	1908.
Germany	\$322	\$915
Manufactures of:		
France	89	272
Germany	18,245	21,833
Italy	14	11
Netherlands	77
Spain	42
Switzerland	12	104
United Kingdom	1,966	1,881
Canada	50
Mexico	1
Japan	301	29
	\$20,747	\$24,180

ALABASTER, MANUFACTURES OF:	1907.	1908.
Belgium	\$7
France	\$60	253
Germany	507	861
Italy	10,887	8,781
United Kingdom	216	1,059
Canada	168
British India	2	5
Egypt	31
	\$11,676	\$11,102

BRAZILIAN PEBBLE:	1907.	1908.
United Kingdom	\$6
Brazil	7,296	\$7,967
	\$7,302	\$7,967

CLOCKS AND PARTS OF:	1907.	1908.
Austria-Hungary	\$3,137	\$2,229
Belgium	711	6,707
Denmark	70	170
France	215,781	227,165
Germany	255,968	291,718
Italy	1,291	1,338
Netherlands	2,194	5,894
Norway	93	93
Russia in Europe	3
Spain	121	22
Sweden	467	12
Switzerland	6,064	9,584
Turkey in Europe	13
United Kingdom	52,103	62,779
Canada	569	618
Mexico	130	57
British West Indies	21
Cuba	47	112
French West Indies	11
Chile	15
Chinese Empire	139	112
Hong Kong	32	20
Japan	825	1,163
Australia	3
Philippine Islands	20
French Africa	232
	\$539,793	\$610,060

WATCHES AND PARTS OF:	1907.	1908.
Austria-Hungary	\$2,267	\$2,233
Belgium	29,642	9,654
Denmark	96	403
France	162,785	236,510
Germany	193,164	245,787
Greece	5
Italy	57,833	75,566
Netherlands	3,220	1,624
Norway	138	118
Roumania	8
Spain	484
Sweden	7	51
Switzerland	2,041,841	2,336,556
Turkey in Europe	26	5
United Kingdom	73,082	71,522
British Honduras	9
Canada	615	1,120
Newfoundland	26	7
Costa Rica	5
Honduras	12
Nicaragua	18
Panama	58	230
Mexico	45	113

British West Indies	179	187
Cuba	92	177
Danish West Indies	11	15
Argentina	20
Brazil	21
Colombia	13	158
British Guiana	10	120
Peru	25	30
Venezuela	5
Chinese Empire	233
Japan	76	83
Australia	37	4
Philippine Islands	17	58
	\$2,565,343	\$2,983,113

DIAMONDS, UNCLUT:	1907.	1908.
Belgium	\$2,079,136	\$1,517,672
France	567,572	1,518,876
Germany	14,103	115,069
Netherlands	944,376	742,681
Switzerland	1,440
United Kingdom	6,964,543	7,106,920
Canada	23,570
Mexico	34	8,100
British West Indies	12,190
Brazil	5,072	103,571
British Guiana	4,610	3,983
British Oceania	8
	\$10,579,654	\$11,154,152

DIAMONDS, CUT BUT NOT SET:	1907.	1908.
Austria-Hungary	\$1,625
Belgium	\$4,578,361	5,201,211
France	5,007,792	3,390,995
Germany	195,343	157,550
Netherlands	10,192,821	11,458,654
Russia	500	687
Switzerland	16
United Kingdom	4,307,811	3,752,871
Canada	163
Mexico	90
Brazil	1,832
Hong Kong	13
	\$24,282,897	\$23,965,438

DIAMOND DUST OR BORT:	1907.	1908.
Belgium	\$9,209	\$338
France	15,991	120,957
Germany	403	9,248
Netherlands	62,023	4,445
Switzerland	416
United Kingdom	46,126	48,303
Canada	5,414
	\$133,752	\$189,121

OTHER PRECIOUS STONES, UNCLUT:	1907.	1908.
France	\$21,502	\$36,897
Germany	43,329	25,559
Spain	136
Switzerland	29,396	40,228
Turkey in Europe	1,482
United Kingdom	19,430	11,889
Canada	520
Mexico	158	2
China	118
British East Indies	36,423
Japan	4,134
Australasia	7,962	3,209
	\$126,047	\$156,327

DIAMONDS AND OTHER PRECIOUS STONES, CUT BUT NOT SET, INCLUDING NATURAL PEARLS:	1907.	1908.
Austria-Hungary	\$370,031	\$474,089
Belgium	625	9,260
France	2,625,654	5,012,727
Germany	839,028	761,218
Italy	666	12,273
Netherlands	896
Russia	837
Sweden	10
Switzerland	37,734	21,110
United Kingdom	1,377,911	664,929
Canada	1,716	1,999
Panama	60
Mexico	4,673	35,535
British West Indies	25
Haiti	35
Chinese Empire	319	898
British India	15	698
British East Indies	350	2,865

Hong Kong	22	350
Japan	3,042	2,574
Turkey	122
Australia	486	125
Philippines	5	368
Egypt	16

GLASS ENAMEL FOR WATCH AND CLOCK DIALS:	1907.	1908.
Belgium	\$83
France	\$4,886	10,534
Germany	1,886	2,112
Switzerland	438	440
United Kingdom	1,247	542
	\$8,457	\$13,711

GOLD AND SILVER SWEEPINGS:	1907.	1908.
Germany	\$40
Netherlands	\$80
Switzerland	100
United Kingdom	50
Canada	97,516	114,831
Mexico	10
British West Indies	5	5
Cuba	2,000
	\$97,661	\$116,976

JEWELRY AND MANUFACTURES OF GOLD AND SILVER:	1907.	1908.
Austria	\$220,490	\$185,380
Azores	93
Belgium	1,430	1,916
Denmark	560	654
France	750,165	649,270
Germany	505,596	688,654
Gibraltar	18
Italy	26,292	38,117
Malta	150
Netherlands	8,738	10,497
Norway	1,203	1,157
Portugal	6
Roumania	5
Russia	5,577	2,293
Spain	1,283	2,962
Sweden	310	117
Switzerland	4,305	12,541
Turkey	103	49
United Kingdom	174,529	145,855
Bermuda	16	17
British Honduras	47	63
Canada	7,399	7,666
Newfoundland and Labrador	7	13
Costa Rica	4	98
Guatemala	43	21
Honduras	2	2
Nicaragua	2
Panama	147	595
Mexico	4,307	4,103
British West Indies	628	469
Cuba	402	1,093
Danish West Indies	102	3
Dutch West Indies	39
Argentina	3	37
Brazil	50	198
Chile	137	16
Colombia	70	286
British Guiana	64	118
China	4,845	8,846
British India	6,670	638
British East Indies	279	775
Hong Kong	1,190	2,505
Japan	10,006	10,579
Turkey	161	157
Australia	1,346	625
Philippines	194	318
British South Africa	16
French Africa	97
Egypt	1,114	532
	\$1,739,953	\$1,779,527

At a meeting of opticians held recently at the store of Harris & Johnson, Chattanooga, Tenn., it was tentatively decided to have the annual meetings of the Tennessee Optical Society and the Tennessee Retail Jewelers' Association on June 22 and 23. Both associations decided at their last meetings to come to Chattanooga, but left the time to local members. A committee on Ways and Means was appointed as follows: T. H. McClure, H. W. Johnson, and J. E. Jahnke. It is expected that several hundred delegates and visitors will attend the joint convention.

WM S. HEDGES & CO.,

IMPORTERS AND CUTTERS OF

DIAMONDS.

Precious Stones and Pearls.

170 Broadway, Corner Maiden Lane, New York.

27 Holborn Viaduct, London.

EMERALDS

IN CURRENT SIZES AND GEM PIECES

SAUNDERS, MEURER & CO.**65 Nassau Street****NEW YORK****Goodfriend Bros.**

Importers of

**Pearls and
Precious Stones****CAMEOS****9-11-13 Maiden Lane****NEW YORK****PARIS
10 Rue Cadet****PROVIDENCE
212 Union Street**

C. C. Cardon will shortly open a store at Glasgow, Ky.

E. R. Kennedy is a new jeweler in La Crosse, Kans.

T. V. Sherman is a new jeweler in Colorado Springs, Colo.

A. B. Talton has opened a new jewelry store in Alexandria, La.

I. R. Baker has engaged in the jewelry business in Liberal, Kans.

Fred T. Petrequin has begun business at 314 Grand River Ave., Detroit, Mich.

Carter & Son will open a new jewelry store in Greeley, Colo., about May 1.

D. A. McComb has started in business at Monroe and Baneroff Sts., Toledo, O.

L. Randazzo has just engaged in business at 121 E. Missouri Ave., Kansas City, Mo.

A. L. Hamm recently commenced business as a retail jeweler in Garland, Kans.

Ralph Simpson, Wahoo, Nebr., will soon open a jewelry store in Falls City, in the same State.

P. E. Osborn is about to open a department store in Ontario, Cal., and will carry a line of jewelry.

R. E. Harrington is about to open a store in Kansas City, Mo. He will carry a line of jewelry and dry goods.

Samuel McDowell, who some years ago conducted a store in Chippewa Falls, Wis., has re-engaged in business at the same place.

C. G. McCormick has opened quarters in the Schofield building, Cleveland, O., where he will conduct a general repairing business for the trade.

S. C. Bingamin, Boston, Mass., will open a jewelry store under the name of "The Crown," about May 1, at 5th and Vine Sts., Cincinnati, O.

M. I. Kirkman, until recently in the employ of E. J. G. Lovett, Titusville, Pa., contemplates engaging in business for himself in Anderson, Ind.

The Broek Mfg. Co. was incorporated, last week, in Oklahoma City, Okla., with a capital of \$75,000. The incorporators were L. P. Stout, J. D. and W. S. Brock.

Chas. W. Sommer has begun business on his own account as a dealer in diamonds, pearls and precious stones. He has opened an office at 68 Nassau St., New York.

The Cleveland Watch Case Co., of which A. B. Shannon is manager, announces the opening of a shop at 746 Euclid Ave., Cleveland, O., devoted exclusively to the repairing of watch cases.

William N. Stoek and Harry J. Bickle, for several years engaged with Ryrie Bros., Toronto, Ont., have started in business on their own account in Toronto, where they have opened a handsomely equipped store at 131 Yonge St.

Death of Isaac Friedman.

Isaac Friedman, late a member of the firm of Dattelbaum & Friedman, manufacturing jewelers, 51 Maiden Lane, New York, died Monday evening at his home, 798 Lexington Ave., Manhattan, as a result of a complication of diseases after an extended illness.

Mr. Friedman was born in Hungary in 1838, and came to this country as a young man, becoming connected with the jewelry trade in New York many years ago. In 1875 the firm of Dattelbaum & Friedman was formed, of which he was a member until 1900, when he retired.

Deceased was a member of Sulamith Lodge 167, U. O. B. B., and the United Brothers Lodge. The funeral was held yesterday from Mr. Friedman's late residence. Interment took place in Linden Hill Cemetery.

Deceased is survived by a widow and three children.

Stanley J. Peters Vindicated After Being Brought to West Virginia for Trial.

ALLENTOWN, Pa., April 17.—Stanley J. Peters, the young jeweler of this city, who was taken to Bramwell, W. Va., to answer a charge of grand larceny, was completely vindicated there on Monday and was discharged by the court.

Peters, it will be remembered, was arrested on papers brought to this city by Sheriff Farley, of Bramwell. Declaring that the arrest was unjust, he resisted the extradition and habeas corpus proceedings were instituted by his attorney, Lawrence H. Rupp. Judge Trexler held a hearing after which Peters was delivered to the sheriff.

Peters was taken to West Virginia, where his family and his father joined him. His case was the first called at the criminal court on Monday morning. Immediately upon its being called, the district attorney declared the commonwealth had no case and asked that he be discharged from custody.

By his arrest and removal, Mr. Peters was compelled to close down his jewelry business in this city and was subjected to great loss. There is a likelihood that he will bring suit to recover damages for false arrest.

"Next Room" Game Worked Successfully on Clerk of Worcester, Mass., Jeweler.

WORCESTER, Mass., April 15.—Meyer Kaufman, jeweler of 130 Front St., reported to Chief of Police Matthews last night that he had been robbed of three diamonds, valued at \$400, by a stranger who worked an old trick.

The stranger went into the store yesterday afternoon, and after buying a clock for \$1.50, asked to see some diamonds. He said that he would like to show three of the diamonds to his wife, so she could take her choice. Abraham Roebbling, a clerk, took the diamonds and accompanied the stranger to 46 Orange St. The man asked the clerk to let him take the stones into another room to show them to his wife. He has not been seen since.

The woman who conducts the boarding

house at 46 Orange St., said that the man hired the room Monday, saying that he was employed by Swift & Co. at their branch in this city.

J. W. Mealy Claims That Bank Obtained a Receiver for His Company by a Legal Trick.

BALTIMORE, Md., April 20.—On complaint of the Third National Bank a decree was signed last Thursday appointing a receiver for the John W. Mealy & Sons Co., 18 W. Lexington St., by Judge Gorter in Circuit Court No. 2. The court appointed Capt. Robert M. Spedden, former president of the bank, as receiver, the bond being for \$120,000.

In its application for a receiver the Third National Bank stated that the company owes the bank \$3,200 on a promissory note dated Oct. 31, 1907, and that its total indebtedness is more than \$50,000. It was also alleged that the company is hopelessly insolvent, and that its business having fallen off in recent months, its ability to pay its debts is becoming smaller. An answer was filed by the defendant admitting the indebtedness as referred to in the petition, but denies that it is insolvent.

John W. Mealy, president of the company, characterized the application and appointment of a receiver as a legal trick, the whole affair being based on a note given the bank to enable the firm to tide over the loss during the great fire that swept the business section in 1904. Mr. Mealy's statement of the difficulty is that at the time of the organization of his business, immediately after the Baltimore fire, the Third National Bank of Baltimore, in consideration of a settlement then made with Mealy's creditors and the consent on their part to allow the bank to be paid in full for its claims, entered into a contract with Mr. Mealy and all his creditors at that time to give him a line of credit for a period of five years, according to the terms of the contract.

Mr. Mealy claims that he has lived up to this contract in every respect, and, in fact, the bank admits that he has, but nevertheless the bank has decided to try to break this contract. By the terms of the agreement the bank was given a majority representation on Mr. Mealy's board of directors—these directors are also directors of the bank—and at a meeting held on Thursday, without notice to any one, passed a resolution instructing one of their members to go into court and consent to the appointment of a receiver, although none of Mr. Mealy's other creditors were pressing.

Mr. Mealy contends that he is not insolvent, and that he is able, if the bank will live up to its contract, to meet all of his obligations.

The John W. Mealy & Sons Co. is one of the best known of the local jewelry houses. Previous to the great fire of 1904 it was located on Charles St., near German St., locating at its present home shortly after being burned out.

Harry Guber, Altoona, Kans., has moved to Kansas City, Kans.

C. Wright, Wyndmere, N. Dak., has moved his stock into the Klensing building.

News Gleanings.

F. T. Huntington, formerly of Fulton, N. Y., is now at Topeka, Kans.

F. M. Schouweiler has succeeded C. L. Ekberg, at Red Wing, Minn.

J. A. Robinson, Whitefish, Mont., has moved his stock into new quarters.

W. T. Marcuson, Lincoln, Nebr., is a new jeweler in Guthrie Center, Ia.

S. Perkin, Allentown, Pa., has moved his stock to a new store at 128 N. 6th St.

W. J. Glaum, Detroit, Minn., left for Peoria, Ill., recently, where he will take a course in jewelry and optical work.

N. C. Anderson, Fargo, N. Dak., has been appointed official watch inspector for the Fargo, Minnesota and St. Paul divisions.

The partnership of Peterson & Williams, Cannon Falls, Minn., was recently dissolved, Geo. V. Williams taking over the business.

The residence of G. A. Donaldson, Girard, Ill., has been destroyed by fire. The residence was recently built at a cost of about \$5,000.

R. P. Jahnke, Gonzales, Tex., has rented a building in Luling, Tex., where he will shortly engage in the jewelry business. M. V. Pendleton will manage the concern.

A. E. Kintner, Amesville, O., is selling out his stock at auction, prior to discontinuing business. Mr. Kintner intends to engage in other lines in a new territory.

H. O. Ballou, Norton, Va., who recently made a conditional assignment, has moved his stock from 6th St. into his old stand on Park Ave. The trustee's sale is being continued.

H. E. Adams, Tampa, Fla., left, last week, for a trip over the coast line to Port Myers, to look after the regulation of timepieces of the employes of the railroad, of which he is watch inspector.

Burglars, a short time ago, broke into the store of the Ellsworth Supply Co., Ellsworth, Pa., and escaped with several watches, watch chains, pins and necklaces, valued in all at several hundred dollars. A reward of \$25 has been offered by the concern for the apprehension of the thieves.

J. W. Jarvis, for many years located at 508 Main St., Buffalo, N. Y., has moved into his new optical quarters at 214 Franklin St. The building was remodeled especially for Mr. Jarvis' business and is one of the largest naturally lighted optical stores in Buffalo. The entire front is of glass, which extends several feet on either side of the entrance. The factory in the rear is lighted by skylights and one side is all windows.

Besides endeavoring to obtain specimens of silverware of Philadelphia's infant industries in its early history for display during the Founders' Week celebration, as announced in these columns last week, the Historical Committee of the celebration is now trying to secure exhibits of cut glass ware made in the Colonial and Revolutionary period and the early part of the 19th century. A partial list of the important early glass factories is as follows: Caspar Wistar, Allowaystown, 1738-1752; Baron Henry W. Stiegel, Manheim, 1762-1771; Kensington Glass Works and Dyottville Glass Works, 1771; Whitney Glass Works, 1775; S. Huffney, about 1850; A. R. Samuels, 1855; Pastorius also mentions three in Frankford in 1684.

BLACK OPALS

REMARKABLE :: IRIDESCENT :: BEAUTIFUL

Black Opal, a recent Australian discovery, is one of the most beautiful stones hitherto found.

With it many inimitable jewelry creations are possible that must appeal in a forceful manner to the trade.

These remarkable stones exhibit a wonderful play of brilliant colors, ranging from light to cobalt blue, with flashes of violet, from delicate shades of green to peacock green, and all shades of reds, merging into orange and yellow tints.

Black Opal is a worthy addition to the finest stock, and jewelers will find it a welcome "Trade Magnet."

We can furnish these stones in various sizes and shapes, and their full merits can only be appreciated by being seen.

We make a specialty of AUSTRALIAN and MEXICAN OPAL MATRIX.

BUY FROM THE CUTTERS

AMERICAN GEM & PEARL COMPANY

14 & 16 CHURCH STREET, NEW YORK

London, 16 Holborn Viaduct

Paris, 39 Rue de Chateaudun

FROM MINES TO MARKET

CORAL

All Kinds of Coral
Specialties for Jewelers

**DROPS
BUTTONS
LENTILLES**

**CORAL
NECK-
LACES**

All Shades
and Sizes
Graduated and
Uniform



CORAL MANUFACTURING COMPANY

CORAL

**Extra Rose
CORAL
A Specialty**

Gold Medal
St. Louis, 1904

Grand Prix
Liege, 1905

BORRELLI & VITELLI

3 Via Amedeo,
Terre del Greco Italy

401 Broadway, New York
Telephone, 5412 Franklin

19 Rue d'Hauteville,
Paris, France

LOUIS FELDENHEIMER

Importer and Cutter of

PRECIOUS STONES AND PEARLS

41 MAIDEN LANE

NEW YORK

Philadelphia.

William C. Robertson, manufacturing jeweler, 725 Sansom St., spent the Easter holidays at Atlantic City. N. J.

Good Friday was observed as a half-holiday by all the leading wholesalers and manufacturers in this city.

The sympathy of the trade is being extended to T. D. Bentley, 1107 Girard Ave., whose wife is critically ill.

Alfred Gallaschick, watchmaker, with Joseph M. Parker, 12th and Sansom Sts., has recovered from a serious illness.

Richard Wilde, local representative of the Meriden Cutlery Co., started Monday for a three weeks' canvass of the Pennsylvania State trade.

Robert C. Green, a prominent Pottsville, Pa., retailer, was in this city, last week, accompanied by Mrs. Green, combining business and pleasure.

William Norton, with S. Kind & Sons, has returned to his duties after being confined to his home for some days with a severe attack of rheumatism.

C. F. Rumpp & Sons, manufacturers of leather novelties, started, last week, to operate their big factory at 5th and Cherry Sts. on a two-thirds time schedule.

Col. J. Warner Hutchins, 728 Sansom St., was appointed, last week, by Mayor Reburn a member of the Military Committee to plan the celebration of Founders' Week next Fall.

Arthur Bixler, of C. W. Bixler & Co., Easton, Pa., visited this city, last week, in company with his wife, and remained over until Sunday evening to spend the Easter holidays here.

W. W. Leight, watchmaker for R. T. Ferguson, 2357 N. Front St., has been extended the sympathy of his friends in the trade owing to the death, last week, of his 14 months old son.

Paul Souder resigned his position as buyer of the silverware department of Wanamaker's, last week, to accept a responsible position as Philadelphia agent for a New York hotel supply house.

H. B. MacFarland, Downingtown, Pa., accompanied by his daughter, spent a few days, last week, in this city, where Miss MacFarland did some shopping in preparation for her approaching marriage.

Jesse L. Browne, southern salesman for M. Sickles & Sons, returned, last week, from a three months' trip. Elmer Horn, head of the material department, spent the Easter holidays at his parents' home in Easton.

Many rare and costly objects of art, rich porcelains, silverware, Sheffield plate, high case tubular chime hall clocks and cut glass ware will be disposed of at auction, as part of the estate of the late John Woodside by M. Thomas & Sons, the latter part of this week.

Seaman & Struntz, Frankford, took possession of their new downtown store last week. This is the establishment recently vacated by Taylor & Co., at 11 S. 9th St., opposite the Central Post-Office. The Frankford store will be continued as heretofore.

The Philadelphia Jewelers' Club has completed arrangements for the smoker and vaudeville entertainment to be given at the

club quarters April 28. It is expected that a large delegation of New Yorkers will attend as well as retailers from towns and cities nearby.

Herman Diesinger, a widely known retired silversmith, was elected last week a director of the Ridge Ave. Bank.

Joseph Goodman, a member of the bankrupt firm of Sperling & Goodman, formerly of 8th St., near Vine St., made application Wednesday of last week to the United States District Court for his discharge from bankruptcy. A hearing on the application will be held May 6.

Louis P. White, wholesaler, 9th and Chestnut Sts., journeyed to Atlantic City, N. J., Saturday in an automobile with a party of friends to enjoy the Easter holidays at the seashore. George W. Fisher, with L. P. White, is confined to his home suffering from tonsillitis.

Frederick T. Berry, formerly with J. A. & S. W. Granbury, who resigned to travel the middle west and eastern States for Louis Stern & Co., Providence, R. I., was in this city last week visiting his family in Germantown preparatory to starting on his initial trip for his new house.

Among the visitors to this city's trade during the week were the following: A. Mitchell, Atlantic City; H. V. Stratton, Bordentown, N. J.; Charles Kohler, Norristown; E. P. Ledos, Newark; R. W. Quicksall, Mount Holly; V. L. Phillips, Smyrna, Del.; R. C. Green, Pottsville.

D. V. Brown, wholesale and manufacturing optician, 740 Sansom St., has been appointed by Judge Holland, of the United States District Court, receiver of the bankrupt estate of Gabriel Mayer, 728 Sansom St. Efforts will be made to dispose of the property for the benefit of the creditors as a going concern.

A sectional civic display by the merchants of Germantown Ave., between York St. and Montgomery Ave., last week, was participated in by the retail jewelers of the street, including William Gsand, George S. Katz, B. Cohen, A. F. Martin and B. Foster, whose stores were attractively decorated and illuminated during the evenings.

Adolph Broza, formerly a wealthy real estate operator of this city, who has been a fugitive from justice for about a year, charged with presenting a worthless check to Charles H. Dean, diamond broker, 717 Sansom St., in payment for diamonds purchased, was brought back to this city from Chicago, last week, by detectives and committed to prison to await trial.

Mrs. Y. Hari, wife of a leading jeweler of Osaka, Japan, was a visitor to this city, last week, in company with a party of 56 Japanese, who are on a tour of the world. Mrs. Hari displayed a keen interest in the leading Chestnut St. retail jewelry stores, and declared that she will have an abundance of "tips" to give her husband on the management of his business and the decoration of his store in Osaka when she returns home.

James Girvin Maree, once one of the most prosperous as well as one of the best-liked retailers in the city, who for many years conducted a jewelry store in Manayunk, but who is now retired, celebrated Monday night the 57th anniversary of his marriage at the home of his son-in-law,

William L. Nassau, 424 W. Chelton Ave. Mr. and Mrs. Maree were the recipients of many tokens of esteem from old friends in the jewelry trade.

Col. J. Warner Hutchins spent the Easter holidays with the members of the Wish Bone Club, an inner club of the Union League, at the new Hotel Cape May, at Cape May, N. J. Col. Hutchins was one of the first to be registered at the new hotel when it was opened, last week, and has long been identified with the Summer colony of the resort and has been interested in a business way in the rejuvenation of the former premier Atlantic coast resort.

M. I. Darevski, who has one of the most attractive of N. 8th St. retail stores at 134, preserved his nerve and presence of mind when a burly man attempted to rob him last week. The man entered the store in the guise of a customer and pretended he wanted to buy a watch. When one was shown to him he bolted for the door. But Darevski intercepted him and held him at bay until a policeman arrived. The man gave his name as Thomas Morrissey, and said he came from the Pacific Coast. He was sent to jail for one year.

News of the death of Wilson Oplinger, a prominent retail jeweler, for about 10 years in business in Weissport, Pa., and a frequent visitor to the trade of this city, was received here last week with deep regret. Mr. Oplinger's death was entirely unexpected. He had seemed to be in the best of health. The funeral was held Wednesday in Weissport. Mrs. Oplinger, widow of the dead jeweler, is just recovering from typhoid fever. It is believed that the stock and fixtures of the store will be disposed of by the widow.

The Retail Clerks' International Protective Association was organized in this city last week, with Oscar C. Hansen, president, and Ross B. Ashenfelter, secretary. The headquarters are at 999 N. 5th St. It is planned to take up a thorough systematic organization of the retail clerks in the city, including clerks and salesmen of retail jewelry stores. The city is to be blocked by business rather than wards with a view of organizing locals for the various enterprises represented in the parent local, so that each business will have a separate organization of its own.

On suspicion of having been the thief who robbed Mrs. McIntire, a daughter of E. P. Percival, jewelry auctioneer and retailer at 147 N. 8th St., of \$1,000 worth of jewelry, Alfred Hart, aged 27 years, 6th St., near Callowhill St., was arrested, Friday, while he was being held up and robbed himself in Franklin Sq. by three men. The police saw the hold up and when they went to Hart's rescue discovered that he was the man they had been looking for as the burglar who robbed Mrs. McIntire. The men who held him up were captured later. All four were committed to jail in default of bail for \$1,000.

Oscar F. Sturmer, the Easton jeweler, who committed suicide Friday night by jumping from a railroad train while crossing the Susquehanna river at Havre de Grace, was well known to the trade here, particularly in the wholesale district, which he visited often to purchase stock. Apparently Sturmer was in the best of health

and one of the last men who might be expected to kill himself. General regret is expressed in this city by his friends at his untimely and unfortunate end. A brother, who is also known here, has charge of Lyons & McPherson's jewelry store in Tamaqua.

Three or four dozen pieces of the finest pottery, bronzes and ivories, the finds of a season's exploration in the Orient by members of the faculty of the University of Pennsylvania, are on their way to this city to be added to the Free Museum of Science and Art. The university will also have a copy of the great bowl, engraved in the Ethiopian style, of a king and queen with their courtiers and cattle. The original will stay in Cairo. Ninety boxes of beads and rings and vases are also coming here. This news was dispatched to the university officials last week by Dr. MacIver, the curator.

Wholesale jewelers of this city were last week informed of the disappearance of Edward Dowd, a prominent retail jeweler of Wilkes-Barre. The announcement of Dowd's mysterious disappearance was made by his wife, who is in ignorance of the reasons for her husband's absence, and knows nothing of his present whereabouts. Dowd was heavily indebted to wholesalers here and elsewhere, and it is believed that financial troubles worried him into taking flight. Mrs. Dowd has offered to settle claims against her husband and has written to that effect to his creditors. The police are looking for the missing retailer.

Henry Stevens, head of Strawbridge & Clothier's store, arranged for the jewelry department, last week, one of the most attractive Easter displays ever made in this city, using in the exhibition many thousands of dollars worth of gems. The figure of a little girl, standing at the brink of a lake feeding grains of diamonds from a half carat upward to three carats to a flock of ducks was one of the most charming pieces. Other pieces shown included a \$1,500 pear, an \$18,000 diamond necklace, a solitaire diamond worth \$3,500, "the materialized sunlight of an Easter day," Mr. Stevens described it; a ruby worth \$1,500, a Ceylon sapphire of perfect hue, brown diamonds, opals and emeralds.

John Anderson, alias Coyle, one of the two men who were arrested last week on suspicion of having been the thieves who chloroformed and robbed Mrs. Liggins, when she conducted a retail jewelry store on 11th St., above Girard Ave., about two years ago, and secured booty valued at \$3,000, was positively identified as one of the men who entered the store by Mrs. Liggins, Thursday. She had failed to identify him after his arrest a year ago. The man arrested with Anderson was released for want of evidence. Anderson is now awaiting trial under \$2,500 bail. As reported in these columns last week, Anderson was arrested through information furnished by a young man who visited the Tenderloin district for a night's outing and accidentally heard Anderson recounting his criminal adventures, among which was the chloroforming and robbing of Mrs. Liggins, widow of a once widely-known jeweler. Mrs. Liggins now resides at 2536 Franklin St.

EICHBERG & CO.,
 IMPORTERS AND CUTTERS OF
DIAMONDS,
 65 NASSAU STREET, (Prescott Building.) NEW YORK.

CROSSMAN COMPANY
BAROQUE PEARL BAR PINS
 3 Maiden Lane, New York

A. ROSEMAN, 9-11-13 Maiden Lane, New York
 IMPORTER OF
DIAMONDS
 Maker of Diamond Jewelry

Established 1872
 HEADQUARTERS FOR
AMERICAN WATCHES
TRADE-MARK.

Janitschek Company
 Inc.
 THIRTY-THREE UNION SQUARE NEW YORK

❧

Die Makers
 Designers
 Casters in
 Gold, Silver
 and Bronze

JANITSCHEK PATENTED DIES

The DIE Incomparable!
The DIE that Revolutionized Die Making!
The DIE that Saves 50 per cent. of Die Cost!

Can you afford to wait longer before trying it?

Particulars and Prices on demand

The "SECURITY" Necklace Clasp



No. 1 Locks here
 No. 2 Locks here

HEAR IT SNAP
 Absolutely Secure and Simple. Cannot Pull Out
LOCKS IN TWO PLACES
 Making it Doubly Secure
The Only Perfect Clasp
 Ask Your Jobber or Write.

Patent applied for.

PRICES TO THE TRADE:

No. 1.	10-Karat,	\$6.00 doz.
" 1-B.	10 "	7.00 "
" 1.	14 "	7.00 "
" 1-B.	14 "	9.00 "
" 2.	10 "	9.00 "
" 1.	Platinum,	18.00 "
" 1.	Gold Filled,	2.00 "
" 1-B.	" "	2.25 "
" 2.	" "	2.50 "
" 1.	Sterling Silver,	2.00 "

The Hoffman Novelty Co.,

"CLINCH"



Safety Catch for Scarf Pins

Does not mar the pin. Nothing to get out of order. Simple and neat.
 One turn to the right grips like a vise.

Patent applied for.

..FITS ANY SIZE PIN..

PRICES TO THE TRADE

No. 1	Gold Plated	\$1.50 doz.
No. 2	Roman Gold	2.00 doz.
No. 2	14k G'd Pl'te	2.25 doz.

No. 1, 25c.

Makers, 79-83 No. Pearl St., ALBANY, N. Y.

Pittsburg.

TRADE CONDITIONS.

The differences between the coal operators and the miners having been settled, the miners will return to work this week. This situation was aggravating and jewelers, along with other interests, had been anxiously watching the controversy between the operators and the miners' organization as the men have virtually been out on strike. The settlement of the trouble means that 35,000 men return to work in this section. This means much to the Pittsburg district. Business has been quiet but better conditions are now hoped for.

William Heeren, of Heeren Bros. & Co., was in Atlantic City last week.

Albert M. Dueber, Canton, O., the well-known watch manufacturer, was in Pittsburg last week on business.

The Washington Infantry, to which a number of jewelers belong, will give a reception and ball Friday evening of this week in the armory.

Sam F. Sipe has hung three fine pastel pictures of horses on the walls of his store. Mr. Sipe is owner of the animals whose pictures he has had painted.

A. A. Gillespie, of Gillespie Bros., who is visiting in Chicago, has not been well, though nothing serious impairs his health. He is taking a needed rest.

L. Hahn & Co. is the name of a new concern which recently opened a wholesale jewelry house at Room 411, Union Bank building, Fourth Ave. and Wood St.

Howard A. Cerf, a son of Sol. Cerf, of Sol. Cerf & Co., spent the Easter holidays at home, having come here from Freehold, N. J., where he is attending a military academy.

John M. Roberts, of the John M. Roberts & Son Co., who circulated a petition addressed to Congress, requesting that no change be made in the stamping of watch cases, has forwarded the petition to Washington.

The following out-of-town merchants were in Pittsburg last week buying stock: George Eckert, Jeanette; F. B. McKelvy, Washington; J. J. Schmidt, Turtle Creek; A. Katzenmyer, Burgettstown; George V. Brady, Washington; Harry Blosser, New Kensington.

The Pittsburg Credit Association and the organization at large is raising a fund to prosecute those dealers who fail under questionable circumstances. It is believed that the action of the association will have much influence in preventing questionable assignments and bankruptcies.

Stewart D. Culin was committed to jail last week by Alderman John Groetzinger on information laid by Loftis Bros. & Co. Culin was charged with getting jewelry for which he refused to pay, or return, but after he had been in jail for several days he came to the conclusion that he was willing to settle the case and that put an end to the matter.

Local jewelers were this week very much interested in the announcement of the return of Charles Fitzgerald, manager of the Pittsburg-Brazilian Dredging Co., which has been organized for the purpose of dredging diamonds from the Jequitinhonha river in Brazil. More than 1,000 tons of gravel are daily being removed from the river, in the hunt for precious stones, and some of the rough found has been placed

on exhibition in this city. Some of the local jewelers have inspected the stones and have expressed diverse opinions regarding their worth. Mr. Fitzgerald has spent two years in Brazil.

Intense interest is manifest in the Jewelers' Duckpin League. Roberts No. 1 team and Wattles No. 1 continue tie for first place in the standing of the clubs. Each team won three games last week. The Terheydens lost three out of four games to the Roberts No. 1 team on Thursday night. The Wattles No. 1 team took three out of four games from the Reeds the same night, and the Wattles No. 2 beat the Vilsaeks three out of four.

Lancaster, Pa.

W. J. Fraser, Sr., Lincoln, who has been on the sick list, is convalescing.

Amos G. Brassie, Chicago, spent several days in Lancaster, last week, en route to New York.

Jules Carter, many years ago a Lancaster jeweler, now in business in Pittsburg, visited old friends here last week.

Most of the jewelers made very handsome displays for Easter week, several showing particularly fine diamond exhibits.

Harper Foreman, Denver, Colo., formerly with Bowman & Musser, Lancaster, has been in Lancaster visiting his sisters.

L. C. Reisner, formerly a Lancaster manufacturing jeweler, has just organized a live stock food and tonic manufacturing company.

Frank Kissinger, watchmaker, who has been in Colorado some months for his health, has returned home greatly benefited by his trip.

Among the jewelers who lately visited Lancaster were: J. H. Sensenig, New Holland; Neilson W. Pinkerton, Manheim; P. J. Stoe, Pittsburg.

Harry Lichtenstein, Coatesville's new jeweler, formerly of Williamsport, visited his brother, Benjamin Lichtenstein, N. Queen St., last week.

Filbrook Watson, a former Lancaster engraver, who has been located for some years at Baltimore, expects to engage in business at Columbia, Pa.

Frank Maurer, formerly with H. F. Andrews, Strasburg, has bought out the latter's jewelry business. Mr. Andrews will devote himself exclusively to the optical business.

William Bepler, assistant foreman of the train department of the Hamilton Watch Co.'s factory, was given a birthday surprise party Thursday evening, and received numerous handsome gifts. A banquet was a feature of the affair.

Jacob T. Bowers, a former manufacturing silversmith of Reading, died on April 16, near Middletown, Pa., in which town he had resided since returning from Chicago, where he lived for some years after retiring from business. He was 72 years old.

E. H. Prey, Canby, Minn., has bought a jewelry and optical business at Watertown, S. Dak., and will take possession about June 1. He is closing out his stock at Canby.

"ASK YOUR JOBBER"



THE UP-TO-DATENESS OF THE UR RINGS IS AGAIN PROVED BY A COMPLETE LINE OF CAMEO GOODS WITH HAND-PIERCED AND SOLID SHANKS IN AN ENDLESS VARIETY.

The Untermeyer=Robbins Co.

Seventy-One Nassau Street, New York

Established and in business since 1894

OUR BUSINESS

DIES

We have been giving satisfaction for the past 14 years.

FINE DIE WORK IS ESSENTIAL FOR FINE JEWELRY, SILVERWARE, ETC. Write us and let us submit for your approval a selection of original designs, made especially to suit your needs.

CREES & COURT

Die Sinkers and Designers 91 Sabin St., Talcott Bldg., PROVIDENCE, R. I.

WORKSHOP NOTES

for Jewelers and Watchmakers
Cloth :: Postpaid, \$2.50
Published by
The Jewelers' Circular Pub. Co.,
11 John St., New York

F. DE SIMONE & SON
Importers of Coral

76 Nassau Street, New York
FACTORY TORRE DEL GRECO ITALY
LEO CAHN
General Representative

MAY FIRST

1908

The

TOWLE MFG. COMPANY

Silversmiths

WILL OPEN

SALESROOMS

17 MAIDEN LANE

THE SILVERSMITHS BUILDING

NEW YORK

GEORGE DAVENPORT LUNT

Manager



FACTORIES
NEWBURYPORT
MASSACHUSETTS

SALESROOMS
CHICAGO, ILL.
42 MADISON ST.

SALESROOMS AT 41 UNION SQUARE ARE DISCONTINUED

Providence.

Harvey D. Gorman pleaded *nolo* to a charge of stealing gold scrap from the shops of the Potter & Buthinton Co., in the Superior Court last week. He had been indicted for the offense by the Grand Jury. He was fined \$250 and costs.

The Todd-Mellor Co., real estate dealers, has brought suit against John Nelson, a refiner and dealer in old metals, to recover \$1,500. In the complaint filed in the Superior Court it is set forth that during February in 1908 an agreement was entered into by which the plaintiff was to negotiate a loan of \$1,500 for the defendant on the latter's note, payable one year from the date of record. The defendant, it is set forth, was to pay \$900 at the consummation of the negotiations as payment on the note for a year. The plaintiff claims that this part of the agreement Nelson has failed to keep, and that he has also refused to execute a note and mortgage and refused to pay the expenses incurred in examining the title of real estate in question.

The will of the late Edgar L. Logee was filed with the clerk of the Municipal Court, this city, Thursday. The case will come up for probate in the Municipal Court. The deceased leaves his property in trust with Dexter B. Potter, an attorney, with power to continue the business if he sees fit. Two-thirds of the net proceeds of the estate are bequeathed to the widow, Susan P. Logee, during her lifetime, and one-third to Mrs. Belle T. Martin, a daughter by a former marriage. Deceased was twice married and was divorced from his first wife. Mrs. Martin is a daughter of the deceased's first wife. In case of the death of the daughter without issue her share of the estate is to revert to Mrs. Susan Logee, and at the death of Mrs. Logee the property goes to Edmund T. Logee, a brother of the deceased. After the death of the wife, daughter and brother the income then remaining shall be paid to the children of the brother, subject to the provision for issue of the daughter. Mr. Potter is named as sole executor without bond. Pending the probating of the will Mr. Potter announces that business will be continued in the shops of the deceased. An inventory is being taken.

Attleboro.

J. W. Maher is head of a new manufacturing house which plans to turn out floral jewelry novelties.

The Old Kirk Cemetery Association elected to office last week Charles O. Sweet, of C. O. Sweet, Son & Co., and John M. Fisher, of J. M. Fisher & Co.

The will of the late Harford A. Capron, the manufacturing jeweler whose death was noted two weeks ago, has been filed for probate. It contains a bequest to the town for park purposes.

Joseph L. Sweet, of the R. F. Simmons Co., and Hon. Sidney O. B'gney, of S. O. B'gney & Co., gave \$250 and \$150 respectively to the fund for the relief of the Chelsea fire sufferers.

W. H. Wilmarth & Co. have nearly completed the refitting of their factory, erected to replace that burned by an incendiary of unsound mind. The main details of the

new plant have been described in these columns. The plant in its completed form is a model of convenience.

The move to place in new hands the big manufacturing and real estate holdings of Charles H. Tappan has thus far come to no finished result. Mr. Tappan's health is such he is disposed under proper conditions to retire, but thus far two propositions in that line have failed of results. A third is reported to have received some consideration.

Egbert E. Rhodes, formerly of Rhodes Bros. & Rothschild, of this town, now in business at Spokane, has notified relatives here of having recently met with a serious accident. While traveling near his home he jumped down a slight elevation, breaking a leg and receiving other injuries. With a table and a telephone extended over his bed he is endeavoring to keep abreast of his affairs in spite of the handicap.

North Attleboro.

Fred S. Gilbert was in New York, last week, on business.

Cheever, Tweedy & Co. closed last week for the annual taking of stock.

Fred Cook, New York representative of Whiting & Davis, was at the factory last week.

Sidney Hall lost part of a finger under the stamp at the factory of Whiting & Davis Friday.

Donations of gold and silver scrap by manufacturing jewelers netted the Women's Auxiliary to the Y. M. C. A. \$139.

William F. Maintien has been primarily instrumental in the establishment of a local branch of the Order of Eastern Star.

The engagement is announced of Dr. Annie Cheever, daughter of Mr. and Mrs. George W. Cheever, to Ernest T. Upham.

The jewelry store of James Over, on Main St., Milford, was robbed and then set on fire Thursday. The fire damage was about \$3,000, and Over claims that jewelry, watches and rings to the value of \$300 were stolen.

George L. Paine and George Angell, of the G. L. Paine Co.; Oscar H. Hornig, of the Codding & Heilborn Co.; Mr. Wilkinson, of J. J. Sommer & Co., and Louis Blackinton left on trips the early part of the week.

The news of the death in New York, last week, of Frank Mauser, narrated in the last issue of THE CIRCULAR—WEEKLY, was received with great sorrow by his host of friends in this town. When a resident of North Attleboro he was a great favorite in business and social circles.

The following nominations have been made by the Erie (Pa.) Board of Trade: For president, L. E. Torrey and B. A. Walker; for first vice-president, W. E. Beckwith and M. L. Davis; for second vice-president, Joseph Davis and William H. F. Nick; for treasurer, H. Beckman and W. S. Carroll; for directors, Z. T. Brindley, G. W. Carter, O. E. Crouch, W. J. Flynn, J. M. Force, A. G. Gibson, J. C. Griffin, C. Hagenlocher, Henry Hinrichs, C. H. Hoffstetter, W. C. Kraemer, L. A. McElroy, J. W. Reynolds, A. Thompson, C. L. Thompson, W. B. Trask, E. A. Walling and C. M. Warner.

Boston.

The Boston Jewelers' Club held its quarterly meeting and dinner at Young's Hotel last evening.

O. P. Burreis, watchmaker, room 88, Jewelers' building, will remove May 1 to room 514, at 21 Bromfield St.

H. B. Burnham, of the Ripley-Howland Mfg. Co., has purchased a farm on Spofford Hill, Georgetown, Mass.

The Waltham Watch Co., last week, donated \$500 to the fund for the relief of the sufferers from the recent fire at Chelsea.

Arthur E. Fish, formerly of Boston, but in recent years salesman for a New York concern, has returned to this city and taken a position with Maynard & Potter in their diamond department.

Freeman & Taylor, retail jewelers, Temple Pl., who are selling out their stock and fixtures on account of the expiration on July 31 of their lease and the contemplated razing of the building, will retire from business on that date.

Among the first 15 permits issued for rebuilding in Chelsea after the great fire were those of Addison Bros. and the J. T. Nelson establishment, recently bought out by G. Willard Frost, who was formerly with A. Paul & Co.

C. H. Skinner, who has purchased from the trustee in bankruptcy all of the assets of his uncle, Alvah A. Skinner, is now conducting business at the old location, 12 Milk St., as successor of Alvah Skinner & Son. With sufficient capital and careful management, he feels assured that he will meet with success.

Henry M. Rich, auctioneer to the trade, is conducting the closing-out sale of the A. R. Grover store, H. J. Landry, manager, at 123 Washington St. He has also been selling out during the past two weeks the stock of Howard C. White, at Enfield, N. H., Mr. White having retired from business on account of ill health.

The Perry-Aldrich Co., which suspended business a few months ago, giving up its salesrooms in the Washington building and making a compromise offer to its creditors, as the result of a disagreement of the principal stockholders, Walter A. Perry and Carl G. Aldrich, has been petitioned into involuntary bankruptcy by four creditors with claims aggregating \$2,925.

The Crescent Watch Case Co., of Boston, through treasurer Charles M. Fogg, last week, filed the following annual corporation report with the Massachusetts Secretary of State: Real estate, \$167,708; machinery, \$241,600; cash and debts receivable, \$343,203; merchandise, \$150,482; investments, \$49,817; capital stock, common, \$200,000; preferred, \$300,000; accounts payable, \$106,423; surplus, \$64,387.

A beautiful Tiffany window, designed by Frederick Wilson, and representing "St. John the Divine" seated, his right hand raised in a gesture of instruction and his left hand holding a chalice, has been presented to Grace Church, Salem, by one of the parishioners in memory of her husband. The color scheme is unusually effective, the background containing a mass of foliage with brilliant sky, while the general coloring is in soft delicate tones of blues and greens and the drapery of the figure is in white and light golden tints.

GORHAM SILVER

"WHEN SPRING UNLOCKS THE FLOWERS."—HEBER

¶ Lent, with its enforced social sedateness, is over, and there follows Spring and the season of Weddings. These latter, if the newspapers may be believed, are this year to be more numerous than ever.

¶ It is, therefore, on the part of the vigilant jeweler merely a precaution born of experience to look carefully through his stock of Gorham Silver and to determine in what direction it needs replenishing in order that he may meet the demands of the buyers of Wedding Gifts.

¶ Months ago Gorham designers and Gorham craftsmen began to prepare for this very occasion by the production of an infinity of suitable articles, ranging from those of artistic and effective trifles to the most elaborate special pieces.

THE GORHAM COMPANY,



CHICAGO,
137 Wabash Ave.

Silversmiths and Goldsmiths

Fifth Avenue and 36th Street, New York.

BRANCHES:

NEW YORK,
23 Maiden Lane.

SAN FRANCISCO,
Temporary Office:
1103 Broadway, Oakland, Cal.



LONDON,
Ely Place.

WORKS: Providence and New York.

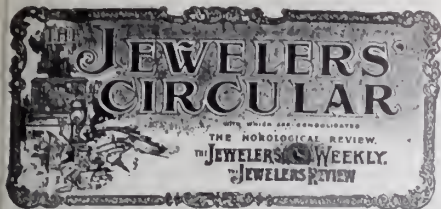

PUBLISHED EVERY WEDNESDAY BY
THE JEWELERS' CIRCULAR PUB'G CO.
 L. J. Mulford, Pres. & Treas. V. S. Mulford, V. P. & Sec.
 11 JOHN ST., COR BROADWAY, NEW YORK.
 TELEPHONE: CABLE ADDRESS:
 1148 CORTLANDT. JEWELAR, NEW YORK.

VOL. LVI. APRIL 22, 1908. No. 12.

Subscription in United States and Mexico, \$2.00
 Dominion of Canada, 3.00
 Other Countries in Postal Union, 6.00
 Single Copies,10

Remit by check or money order. Remittances in money are at sender's risk.

Index to News and Special Articles.

	Page.
Beautiful Casket for Rear Admiral Evans, Made at San Diego, Cal. Illustrated on front cover; text on page.....	39
Jewelry in San Salvador.....	39
Recent Decisions by General Appraisers.....	40
A Modern Cellini on the Island of Capri.....	41
Liabilities and Assets of Max Marcus, Chicago.....	43
Elste Bee's Fashions.....	43
Jewelry, Clocks and Kindred Lines Exported From New York.....	43
Schedules in the Bankruptcy of the Shourds, Adeock, Teufel Co., Chicago—Forty Per Cent. Settlement Offered.....	45
M. L. R. Howald, Salem, O., Makes an Assignment.....	45
Death of Henry O. Dudley.....	45
Involuntary Bankruptcy Petition Filed Against Aaron Mendelsohn, Boston.....	45
Members of the New England Watchmakers' Club Hold Enjoyable Annual Banquet.....	45
Death of Emil H. Koerner.....	45
Attleboro Manufacturing Jewelers Look for a Resumption of Good Business After Presidential Candidates Are Named.....	47
Paris Pearl Market.....	47
Prices of Pearl Shell May Be Higher.....	47
Death of Oscar F. Sturmer.....	47
Imports at New York.....	47
Retail Jewelers of Oklahoma Begin Annual Session at Oklahoma City.....	49
W. H. Hesse, Austin, Tex., Commits Suicide. Judge Refuses to Release Solomon Urbach From Jail.....	49
Chances for American Manufacturing Jewelers to Develop Trade With Brazil.....	49
New Haven Jeweler Causes Arrest at Cincinnati of Man Believed to Have Robbed Many Firms.....	51
Henry Polger Loses Suit for Damages Against Creditors Who Filed Bankruptcy Petition Against Him.....	51
Cincinnati Retail Jewelers' Association Repudiates Attack Made Upon the Officers of the A. N. R. J. A.....	51
Gold Bars Withdrawn and Exchanged.....	51
CIRCULAR-WEEKLY's State Stamping Law Signed by Governor Fort of New Jersey.....	51
More About the Man Who Borrowed Money on Cluster Jewelry.....	51
Silver Market.....	51
Jewelry Imports and Exports.....	53
New Enterprises.....	54
Death of Isaac Freidman.....	55
Stanley J. Peters Vindicated.....	55
"Next Room" Game Worked on Worcester, Mass., Jeweler.....	55
J. W. Mealy Claims Bank Obtained Receiver for His Company by a Trick.....	55
Patent Department.....	83-85
Alfred Curzon on the Lever Escapement.....	87-89-91
Watch Repairing—(Continued).....	93
Selling the Correct Time.....	93
Micrometer Gauge for Heights.....	93
The Best Arrangement of the Storeroom in Order to Get the Maximum Amount of Daylight—(Concluded).....	98
How An Alabama Firm Got Up a Mailing List.....	99
The Way of the Enterprising.....	99
Workshop Notes and Queries.....	101
Exhibition of the Work of Augustus Saint Gaudens at the Metropolitan Museum.....	103
Address of President Rowe Before the Indiana Retail Jewelers' Association.....	105

How Some Jewelers Invite Theft. Experience is undoubtedly the best of teachers, but she is also often the most expensive instructor we can have, and he who would be taught without cost must learn from the experience of others. It is unfortunate, however, that a great many jewelers of this country refuse to profit by the experience of their fellow tradesmen when it comes to the subject of offering opportunity to be robbed, and they will not take heed to the warnings given them from time to time by the police, their protective societies, or by their trade press, but wait before changing their habits or methods of doing business until after they become the victim of a swindler or thief, who has taught them caution in a way that they cannot ignore or forget.

Despite the fact that the Jewelers Security Alliance, THE CIRCULAR-WEEKLY, and even the police departments of various cities have warned jewelers time and time again against having strap handles or padlock staples on the outside of doors that open inward, many merchants still continue to have their doors fixed in this way, and every little while come reports of robberies and the escape of the thieves, who have simply put a bar or block of wood in the strap handle or padlock staple of the door and prevented their jewelry victims from giving pursuit. After a report of this kind had been received at this office, as published in the last issue of THE CIRCULAR-WEEKLY, a representative of THE CIRCULAR-WEEKLY decided to note the number of jewelers in the lower section of New York who practically offer an invitation to thieves by putting themselves out of the way of pursuit in this manner, and within a short walk through the jewelry district in the lower section of New York he counted more than half a dozen stores of enterprising merchants whose doors were arranged in this almost criminally careless manner. There is little reason to believe that the New York merchant is in any way less careful or more heedless than his fellow jewelers in other sections of the country.

Another practical invitation to the thief to come and rob him is offered by the jeweler who will insist on so placing his safe in the store, either against a thin partition or at the back, so that only the front of it can be seen from the entrance. Experience has proven that this position of the safe offers absolute protection to the burglar, who can get at the back as he can drill through the iron and dig out the cement and finally get into the innermost compartment without any danger of being seen by watchmen or police officers who might pass the store at night. Robberies of this kind have occurred time and time again, and jewelers have been warned to put their safes, particularly when they are simply of the ordinary fireproof variety, within a part of the store which is lighted at night, and in such a position that anyone at the side or rear can be seen from some part of the store.

Undoubtedly the appearance of the safe set in this way will not prove as convenient or even as slightly as one set away in the back, protruding through a partition, but safety should be considered by the

The extraordinary success of advertisers in the JEWELERS' CIRCULAR-WEEKLY is due to the enormous buying power of its 8,000 progressive subscribers.

jeweler as important a factor in his business as comfort or appearance.

Fortunately a large part of the members of the trade are conservative merchants, who pay attention to points of this kind, but there is (and it looks as if there always will be) a certain element who never will use common sense in protecting their property, but will always leave themselves open to be the victims of the powers that prey upon their craft.

A DISPATCH from London last week stated that the high court has ordered the Union of London and Smith's Bank to surrender the packet that it had in its keeping which contains the formula by which Henry Lemoine says he can manufacture diamonds. Just prior to this decision, however, and after the Attorney-General had begun his proceedings for this order, the Paris correspondent of the *Daily Telegraph* sent to his paper the following. The italics are our own.

M. Lemoine has had a slight attack of influenza. He has, however, made some further statements which are worth noticing, and one is that the sealed envelope deposited in the London bank *does not contain the formula for making diamonds, but concerns the manufacture of bort.* As regards this, he says that the truth has never before been made public. There were two distinct contracts, one concerning the manufacture of bort, and the other that of diamonds. The second contract was never carried out. M. Lemoine offered no further explanation on this point.

Regarding his future experiments, he will not let the public, and especially the newspapers, into the secret as to the time and place, though he allowed it to be understood that the time would most likely be in July. He does not wish to be disturbed by troops of reporters hanging about his door when he is engaged in the manufacture of diamonds. Of course, he will have to install an entirely new workshop before he can resume operations.

To quote a former comic opera, "It is to laugh," and there is little doubt that the humor of the whole proceeding which seems to have now descended into little more than a farce must be apparent even to those who gave most serious consideration to Lemoine's alleged discovery and thought that he was entitled to the benefit of the doubt until an examination of the formula proved that he was a charlatan.

According to a recent report by Consul-General McFarland, the exports of watches and clocks from Switzerland were valued at \$2,409,517 in 1906 and \$2,522,043 in 1907. The exports of music boxes from the same country were \$43,151 in 1906 and \$32,854 in 1907, while the scientific instruments exported amounted to \$31,508 in 1906 and \$32,850 in 1907.

A Profitable Investment for You



Put your money

and get your customers to put their money in **DIAMONDS** no better investment to-day.

The Jewelers Board of Trade announced recently that cable despatches received here from London said that the De Beers and Premier Diamond Mining Companies, controlling 97 per cent. of all the diamonds mined, had made a contract in which they agreed that there shall not be the slightest reduction from the present prices of diamonds.

We have a large stock of **DIAMONDS** on which we will make very **LOW PRICES** that cannot be duplicated when present stock is sold. We import the stones direct and sell them as close as anybody in the country does for **DIAMONDS** of equal quality. We carry a large stock, Loose and Mounted, and the jeweler who sends to us for a selection not only gets **LOW PRICES** but also a liberal assortment and what is of utmost importance, he gets it promptly. Send us your orders.

V. WARING, N.Y.

CROSS & BEGUELIN

Importers and Cutters of Diamonds and Precious Stones

43 Rue de Meslay, PARIS

Telephone,
480 John

31 Maiden Lane, NEW YORK



Trade-Mark

OUR guiding principle has always been to incorporate as much artistic skill and good material in the construction of our jewelry as possible. This is contrary to the skimming, economic operations so extensively practiced in the manufacture of inexpensive gold jewelry. In observing this standard we naturally sacrifice the petty profits resulting from the less exacting methods of others; nevertheless our jewelry is consistently low priced and of a quality away beyond the ordinary.

Ask to see it and look for our trade-mark—the imprint of originality and all that's good.

85 Sprague Street
PROVIDENCE, R.I.

H. A. KIRBY

9-11-13 Maiden Lane
NEW YORK CITY

Louisville, Ky.

At the seventh annual convention of the Kentucky Optical Association, held April 14 and 15 in Louisville, about 40 members were present. President Fred Pieper, Covington, delivered the opening address, after which several technical papers were read. New officers were elected as follows: President, S. S. Van Hoy, Shelbyville; first vice-president, W. S. Bowen, Winchester; second vice-president, L. J. Bachus, Louisville; secretary and treasurer, Wm. M. Irion, Louisville. The convention, which was most successful, was followed by a dinner and a theater party.

Chief of Police Haager, of this city, has sent out notices to the police departments of other cities, giving a list of the jewelry stolen, April 5, from the residence of L. Huber, Jr., Birchwood Ave., as noted last week. Mr. Huber is the junior member of the firm of L. Huber & Son, jewelers, at 356 W. Jefferson St. The articles taken include a screw diamond stud, 1¼-1/32 carats; a diamond ring, Tiffany setting, 11 16 carats; a diamond ring, Tiffany setting, 6½ carat, engraved "Len Min," and date; a cluster ring, amethyst in the center and 13 small diamonds, small number "8063" on the inside; a two-stone sapphire and diamond ring, ¾ carat, sapphire about same size; a two-stone topaz and diamond ring, ½ carat, topaz about same size; fancy pearl brooch, with 50 half-pearls, ¼-carat diamond; a string of gold beads, about the size of a pea; a button bracelet, chased; two small pearls; two small sapphires and a small diamond, engraved "Minnie"; small chain with heart attached, and an open-face 14-karat gentleman's gold watch, 12 size, gold dial and hands, black figures, 17 jewels, Swiss movement. Jewelers who may be offered any of these articles are requested to wire immediately to Chief Haager.

Canada Notes.

The assets of E. L. Norton, Rock Island, Que., have been sold.

A. Desjardins, watchmaker, Papiéauville, Que., has sold out.

C. E. Frost, Peterborough, has disposed of his business to C. Milburn.

B. Liberman, Toronto, trading under the name of the Dominion Jewelry Co., has assigned to P. Rosenberg.

An action brought for winding up the affairs of W. J. Gardner & Co., Ltd., Toronto, Ont., manufacturers of watch cases, was dismissed by the court, last week.

Out-of-town buyers calling on the Toronto, Ont., trade, last week, included: R. B. Harrison, Pembroke; H. J. Mayhew, Colborne, and J. Hollingshead, Streetsville, all Ontario.

William N. Stock and Harry J. Bickle, who have been for some years with Ryrie Bros., Ltd., have formed a partnership under the name of Stock & Bickle, and opened a store at 131 Yonge St., Toronto. The store is artistically fitted up and decorated, having fittings of solid mahogany and all-glass counter cases.

The jewelry and crockery store of Stanley Wildren, Middleville, Mich., has been destroyed by fire.

New York Notes.

Fred. S. Gilbert, North Attleboro, Mass., was in town last week.

Berland & Nadler, jobbers, at 30 Chrystie St., have moved to 47 Maiden Lane.

J. Roseman, Elmira, N. Y., was at the New York office of his firm last week.

Theodore Kaufmann, of Kaufmann Bros., Pittsburg, Pa., was a caller in town last week.

Samuel Hammond & Co. have moved from 71 Wall St. to the building at 72 Wall St., across the street.

Andrew Morris, manager of G. C. Hudson & Co., North Attleboro, Mass., called on the local trade last week.

Leo Calin, formerly with Borrelli & Vitelli, 401 Broadway, is now with F. De Simone & Son, 76 Nassau St.

Chas. F. Langdon, representing the T. I. Smith Co., has been in the east on a business trip during the past week.

Jacob J. Schmukler will move, May 1, from 122 Canal St. to 131 Canal St., where he will occupy much larger quarters.

F. G. Thearle, of the C. H. Knights & Thearle Co., Chicago, was in town last week. He sailed from this city for Italy on the *Republic*.

Fred. H. Carpenter, formerly traveling salesman for the W. & S. Blackinton Co., was a visitor in town last week renewing old acquaintances.

L. Abrahams, of the London Diamond Syndicate, has been in this city and Washington, D. C., during the past week. He is here on a visit to his daughter.

Peter Birtwhistle, formerly in the jobbing business in London, Ont., was a visitor in this city last week. He returned recently from a three months' trip to Bermuda.

William L. Sexton & Co., manufacturing jewelers, have moved their office from 7 Maiden Lane to 47 John St., where their factory will also be, and where they will have improved facilities.

Albert M. Dueber, president of the Dueber Watch Case Mfg. Co., and the Hampden Watch Co., was in New York last week, and was among the callers at the office of THE JEWELERS' CIRCULAR—WEEKLY Wednesday.

Theo. Kuehl, of Geo. Kuehl & Co., Chicago, is at the Astor House, in this city, and will remain there until May 1. Mr. Kuehl is exhibiting many novelties in Black Forest cuckoo clocks and other makes.

The firm of Vogt & Dose, china and glass importers, has been incorporated under the laws of the State of New York with a capital of \$25,000. The directors are Charles Vogt, Harry Freezer and William Nagel, all of New York.

Charged with attempted suicide, Louis Gordon, a jewelry maker out of work, who lived with his brother at 349 W. 39th St., is in Roosevelt Hospital, a prisoner. Gordon was found in bed in his room with a gas tube between his lips.

Dr. Chalmers Prentice, the Chicago oculist, is now in New York, where he intends to enter the lecture field. He is meeting with much success in interpreting Browning's poems. Dr. Prentice is registered at the Waldorf-Astoria Hotel.

Robert M. McNaught, who was for many

years connected with the detective force in this city, died Friday at his home in Brooklyn, after a lingering illness. He was for a number of years assigned to the Maiden Lane jewelry district, where he was well known.

William Scheer, a manufacturing jeweler at 512 Fifth Ave., sent an errand boy Saturday afternoon to deliver a package containing 12 uncut diamonds, a ring set with diamonds and opals and a bracelet. In front of 322 Fifth Ave. a negro grabbed the package and ran.

Announcement is made of the wedding of Sol van Wezel, for several years connected with the firm of S. L. van Wezel, to Miss Tybil Eugenie Gideon, daughter of Mr. and Mrs. Joseph Gideon, of this city, which will take place at the Hotel Astor April 29.

The New York Plate Glass Co. has purchased from Robert Mortimer, 63 Maiden Lane, and from Paul Sonntag, 91 William St., the two buildings forming an "L" on the northwest corner of and fronting on William St. Plans are being prepared for the erection of an office building to cost \$100,000.

The factory of the New York Diamond Cutting Co. will be removed from Brooklyn to the new Frankel building, 45 John St. The offices of Oppenheimer Bros. & Veith will remain at 65 Nassau St. The statement in last week's issue that the office would be removed to the Frankel building was an error.

There was a large attendance at the Fifth Ave. Art Galleries, 546 Fifth Ave., Friday afternoon at the sale by James P. Silo, of the marble collection from the Fucignas studios, and in the evening at the sale of a private collection of engravings and etchings. In all \$17,850 was realized for the marbles.

The Bulletin of the Merchants' Association of New York, issued April 13, takes up the amendments to the Sherman Anti-Trust Law of 1890. The association presents to the merchants of the country a resolution in opposition to the Hepburn amendments to this act, which was unanimously adopted by the board of directors of the association.

"Col." Daniel S. Ward, who for a great many years has been known as a criminal character in the United States, was sentenced last week at Boston to two and one-half years in a State prison in Massachusetts for forgery. This man visited the trade in New York City some weeks ago, and endeavored to pass fraudulent checks, but was unsuccessful.

The E. L. Spencer Co. will move from 9 Maiden Lane to 17 Maiden Lane about May 1, where the concern will occupy more commodious quarters and will have two offices, one for a salesroom and the other for a private office. The S. K. Merrill Co., which is at present at 9 Maiden Lane, will move to the same building and will occupy offices in conjunction with the E. L. Spencer Co.

The trustee in bankruptcy of Isidore Horowitz and Morris Horowitz, individually, and as partners composing the firm of Horowitz Bros., 196 Canal St., will sell, April 27, 1908, at 12 M., all the property, assets and effects, as well as the outstand-

ing accounts upon the books of the bankrupts, to the highest bidder at a private sale. The bids must be not less than the appraised value of the property.

The annual Spring banquet and meeting of the New York Credit Men's Association will be held at the Hotel Savoy, Thursday evening, April 23, at 6.30 o'clock. In addition to the usual list of speakers, it is intended to make the occasion one of great interest by the introduction of other features. Complying with requests frequently made, the committee has extended to members of the association the privilege to invite ladies to attend the banquet.

The famous mantel designed by Cheret, in the Isaac L. Rice mansion at Riverside Drive and 89th St., has been presented to the Metropolitan Museum of Art by Solomon Schinasi, who purchased the Rice property several months ago. The mantel, 12 feet wide and 13 feet high, is of Caen stone, elaborately carved, with a life-size female figure at either side. It was exhibited at the Paris Exposition in 1900 and received the highest award among works of its class.

Burglars made a haul of \$2,500 in cash and jewelry some time Sunday morning by breaking open the safe in the store of Joseph Goldberg, at 9 Avenue A. Skeleton keys were probably used in gaining entrance, and once inside the burglars, by cutting a hole large enough in a partition to push the safe through, went about their work without fear of being seen from outside. The jewelry stolen consisted of diamond rings, a gold watch, a diamond fob, and other pieces. The cash amounted to \$600.

The bankruptcy petition against Nicholas Geoffroy, formerly a manufacturing jeweler at 170 Broadway, which was filed in November, has been dismissed. A settlement with creditors was made. To merchandise creditors he pays 50 cents on the dollar in notes due Aug. 1, 1908; Feb. 1, 1909; Aug. 1, 1909, and Feb. 1, 1910, and to money creditors he pays 25 cents on the dollar in notes due May 1 and Sept. 1, 1908. The liabilities scheduled in the bankruptcy court were \$128,258, with nominal assets of \$137,616.

Among the recent accessions to the silver and jewelry at the Metropolitan Museum of Art are a silver-gilt collar, Austrian, late 15th century; two panels, Saint Gaul with Bear and Saint John, German, 15th century; 30 medals struck by the Corporation of the City of London to commemorate important municipal events, 1831-1902; silver plaque, Sir Francis Drake, by Rudolph F. Marschall; four medals, by Mossop, Dublin; bronze-plated medal, by G. Dupré; bronze-plated medal centenary of foundation of Natural History Museum, Paris, 1803, by Louis Bottée; silver marriage medal, Paris Mint, by Alphée Dubois, 1903, French; bronze medal of Walburga Spöttl, age 87, by Anton Scharff, 1891, German; 22 Austrian silver and bronze medals and plaques, by various artists; three bronze plaques of the Napoleon family, by David d'Angers; bronze plaque of Tennyson and bronze plaque of Carlyle, by R. B. Goddard, 1893; bronze medal of Dr. Brodic, of London, by Wyon; gold watch, Chester hallmark, 1824, maker S. I. Tobias & Co., Liverpool; gold

1851

The Jeweler's Bank for half a century
in the same location

1908

THE CHATHAM NATIONAL BANK

Broadway and John Street, New York

ACCOUNTS INVITED

GEORGE M. HARD, President FRANK J. HEANEY, Vice-President WILLIAM H. STRAWN, Cashier
C. H. IMHOFF, Vice-President HENRY L. CADMUS, Assistant Cashier

Title Guarantee and Trust Company 176 Broadway (between John St. & Maiden Lane) NEW YORK

Capital and Surplus, \$12,000,000 :: The Depositor's best guarantee is a large capital and surplus, together with conservative management

TRUSTEES

John Jacob Astor, 23 West 26th St., New York
Frank Bailey, Vice-President
E. T. Bedford, President Corn Products Refining Co.
Charles S. Brown, of Douglas Robinson, Charles S. Brown & Co.
Julien T. Davies, of Davies, Stone & Auerbach
William M. Ingraham, Attorney-at-Law, 44 Court St., Brooklyn
Augustus D. Juilliard, of A. D. Juilliard & Co.
Martin Joost, Vice-President Bond & Mortgage Guarantee Co.
Clarence H. Kelsey, President
John S. Kennedy, Retired, 31 Nassau St., New York
Woodbury Langdon, of Joy, Langdon & Co.
James D. Lynch, Retired, 129 East 21st St., New York
Ranald H. Macdonald, of R. H. Macdonald & Co., Real Estate
James H. Manning, President National Savings Bank, Albany
Edgar L. Marston, of Blair & Co.

Wm. J. Matheson, of W. J. Matheson & Co., 182 Front St.
Charles Matlack, 70 State St., Boston
William H. Nichols, Chairman of Board, General Chemical Co.
William A. Nash, President Corn Exchange Bank
Robert Olyphant, of Ward & Olyphant
Charles A. Peabody, President Mutual Life Insurance Co.
William H. Porter, President Chemical National Bank
Frederick Potter, 71 Broadway, New York
Charles Richardson, 1307 Spruce St., Philadelphia
Henry Roth, 1562 Myrtle Ave., Brooklyn
Jacob H. Schiff, of Kuhn, Loeb & Co.
James Speyer, of Speyer & Co.
Sanford H. Steele, of Steele, Otis & Hall, Attorneys
Ellis D. Williams, 560 Drexel Bldg., Philadelphia
Louis Windmuller, of Louis Windmuller & Roelker

BRANCH BANKING OFFICES: 196 Montague St. and 175 Remsen St., Brooklyn; 350 Fulton St., Jamaica; 67 Jackson Ave., Long Island City

The Market and Fulton National Bank of New York

ORGANIZED 1852

81-83 FULTON STREET

Capital, \$1,000,000

Surplus, \$1,500,000

PROGRESSIVE — CONSERVATIVE — SUCCESSFUL

ALEXANDER GILBERT, President
R. A. PARKER, . . . Vice-President
T. J. STEVENS, Cashier
JOHN H. CARR, . . . Asst. Cashier

Invites the Accounts of Jewelers
Will extend every facility that good banking will justify

SAFE DEPOSIT VAULTS

THE STATE BANK

376-378 GRAND STREET, NEW YORK

Capital and Earned Surplus, over \$1,500,000. Deposits over Fifteen Millions.

Offers a favorable market for short and long time jewelry and diamond paper.

The Mercantile National Bank

OF NEW YORK

WILLIS G. NASH, President

MILES M. O'BRIEN, Vice-President

WM. SKINNER, Vice-President

WILLIAM H. TAYLOR, Vice-President

EMIL KLEIN, Cashier

DIRECTORS

WILLIAM F. CARLTON,
ROBERT C. CLOWRY,
WILLIAM NELSON CROMWELL,
L. H. CUTTER,
EDWIN GOULD,
HAROLD A. HATCH,

EDWARD T. JEFFERY,
WILLIAM H. LAWS,
WILLIS G. NASH,
BENJAMIN NICOLL,
MILES M. O'BRIEN,
CHARLES E. PERKINS,

DICK S. RAMSAY,
WILLIAM SKINNER,
E. D. STREET,
WILLIAM H. TAYLOR,
E. J. TRUSSELL,
WARNER VAN NORDEN,

Strictly a Commercial Bank
Accounts Solicited

New York Notes.

(Continued from page 65.)

watch, single case, signed Richmond and W. Mitchell. The directors of the Museum have decided to continue the Saint Gaudens exhibition during the month of April.

Blom & Zwaaf, 561 Broadway, Brooklyn, have been succeeded by J. A. Holmans.

W. C. A. Westphal, watch repairer, 180 Broadway, will move, about May 1, to 171 Broadway.

N. Harrison, of Harrison Bros., 14 Maiden Lane, sailed last week for Europe on the *Baltic*.

D. C. Lara, with Stern Bros. & Co., accompanied by his wife, sails for Europe to-day on the *Statendam* for a pleasure trip.

Charles W. Sommer, who, for the past three years, has been with Joseph Frankel's Sons, has started in business on his own account as a dealer in diamonds, pearls and precious stones, and Wednesday last opened his office at 68 Nassau St.

John N. Leiss, formerly of Schultz, Leiss & Co., Newark, N. J., will open an office at 7 Maiden Lane on May 1. He will represent the following Newark manufacturers: Schultz & Lapp, Chas. A. Becker, A. O. Kiefer and the Leedin Novelty Co.

Many friends of Charles A. Gallagher, who for 30 years has been connected with the house of Sinnock & Sherrill as book-keeper and salesman, are grieved to learn that he has been seriously ill at his home in the Manhattan Apartments, 86th St. and Second Ave.

The Standard Jeweled Bearings Co., New York, has been incorporated with a capital of \$5,000. William Hauser and Louis S. Levy, 100 William St., New York; Catharine F. Calahan, 71 Schaeffer St., Brooklyn, are the directors.

The April dinner of the Boost Club will be held to-morrow evening. It will be the last dinner of the season. October will be the date of the next one. The entertainment committee has prepared an interesting programme and it only requires a good attendance to make it a success.

In the account in the last issue of THE CIRCULAR-WEEKLY about the bankruptcy of Chas. F. Wood & Co., the name of Edward Van Dam was mentioned as a creditor. This was an error. The name should have read Em. Van Dam Amsterdam, Holland, who is the creditor mentioned in the petition.

The Brooklyn *Eagle* of Saturday last contained an interesting article on the price of diamonds, giving interviews with leading jewelers of the Borough showing that the market was in no danger of going down. Among the jewelers quoted at length were P. W. Taylor, Alfred Wise, of William Wise & Son, and Mr. Straus, of M. Straus.

The annual meeting of the Jewelers' Bowling League was held on April 14 at the office of the Keystone Watch Case Co. Plans for the coming year were discussed. Present indications indicate that there will be more houses represented in the league than in previous years. Any team desiring admittance to the league should make ap-

plication at once to the secretary. The following officers were elected: R. H. Woodrow (Cross & Beguelin), president; W. E. Ward (N. H. White & Co.), vice-president; A. C. Copouilliez (Cross & Beguelin), treasurer; H. Labouseur (Jos. Fahys & Co.), secretary.

Bernard J. Wiener announces that on May 1 his factory at 45 John St., which is now being fitted up with up-to-date machinery, will be open for the purpose of cutting, recutting, polishing, repolishing, sawing and cleaving diamonds for the trade. Mr. Wiener has worked for large concerns in Europe and in this country, and has had long experience in this line.

Emil Zuckerman, of 351 E. 83d St., is the inventor of a new machine soon to be placed on the market by which ovals and eclipses may be cut in silver or other metals, mechanically, in any size or general form desired. The machine is operated in somewhat the same manner as that for cutting circles now in use, and is said to be the only one ever made that will cut ovals.

Chauncey G. Stone, for more than 30 years in the jewelry business in this city, died Sunday from a complication of diseases at his home, 402 W. 153d St. He was at one time in business at 30 Sixth Ave., where he sold a line of clocks. He was a member of one of the volunteer fire companies in this city. Mr. Stone, who was 84 years old, is survived by a widow and four children.

A meeting of creditors of Greenwood's, Inc., Norfolk, Va., was held Friday at the room of the Jewelers Board of Trade, at which time an offer of settlement at 50 per cent. was made. The payments suggested are 20 per cent. in cash, 20 per cent. in notes of five per cent. each, payable in three, six, nine and 12 months, and indorsed. The remaining 10 per cent. on a note for 15 months undorsed.

A meeting of creditors of Geo. H. Goodheart, 320 Fifth Ave., was held at the offices of Spiro & Wasservogel, 140 Nassau St., Monday afternoon, at which time an offer of a settlement at 25 per cent. was submitted. The payments are to be as follows: 10 per cent. cash, five per cent. Sept. 1, and 10 per cent. Nov. 1, by notes indorsed by E. H. Kruse. The assets are estimated at \$2,000, although nominally about \$3,500, with liabilities of \$5,200. Mr. Goodheart admitted pawning stock, the cost price of which was \$1,700, on which he raised \$700. He claims the money was used to pay his debts. Most of the creditors agreed to the settlement.

Abner Dexter, the oldest expressman in the employ of the United States Express Co., so long a familiar figure in the Maiden Lane District, this week celebrates his half century at this business. He was born June 14, 1836. Soon after his marriage he first became an employe of the company, with which he has been connected since April, 1858. He is 72 years old in June and is still one of the most efficient men in the service. He was first located in the Washington St. district for a short time and was then transferred to the Maiden Lane district. Last year he took a leading place in the parade of expressmen. He has always been employed on a wagon. His many friends in the

Lane extend congratulations on the advent of his 50th anniversary and wish him many years of continued health.

Daily papers during the past week have printed a story to the effect that \$680 was secured from Benjamin Gross, diamond broker of 36 W. 112th St., and that Harry Jacobs has been locked up charged with aiding and abetting an unknown man in securing these goods. According to the police, Gross was introduced by Jacobs to a man in the cafe of a hotel. Jacobs is alleged to have told Gross that the stranger had 10 unset diamonds which he wanted to dispose of. Gross offered \$1,000 for the diamonds but the man wanted \$1,200, so the police say. Finally Gross and the stranger went to the cafe on a second evening and in this place Gross alleges that he gave the stranger \$680, with the understanding that the remainder was to be paid the following day. On Sunday Gross went to keep his appointment but the stranger failed to appear and he became suspicious. An appraiser was visited and it was discovered that the 10 unset "diamonds" were worth about 10 cents.

A man who, it is claimed, had been trying to rob several Brooklyn jewelry stores, visited two Fulton St. shops last week. He was recognized in each place and managed to make good his escape before the police could be summoned. The first store he visited was the store of H. J. Bridger, 472 Fulton St. The clerk who waited on him was suspicious of his actions, and while she permitted him to see several diamond brooches worth about \$300, she did not give him an opportunity to get them in his possession. He finally took his departure, saying he was not satisfied and went directly to the store of P. W. Taylor, 466 Fulton St., where he asked to be shown some jewelry. He was recognized at this place by a young lady clerk as a caller who had tried to fraudulently obtain jewelry at the same place last Fall. At this shop none of the jewelry was removed from the show cases, and the clerk started to warn Mr. Taylor, the proprietor of the store, and telephone the police, but before she could reach the telephone the man bolted out of the door and jumped on a passing trolley car. The man who visited the jewelry stores last week is apparently a Spaniard or Cuban, and speaks broken English. He is 45 to 48 years of age, with dark brown eyes, close together, and dark brown mustache and mixed gray hair.

The examination of George H. Carpenter, against whom an involuntary petition in bankruptcy was filed in the United States District Court, New York, a few weeks ago, was continued last Thursday before Referee Peter B. Olney. Morris C. Dreshfield was again on the stand as witness in this matter and 16 bonds of the American Sparklets Co., valued at \$1,000 each, were placed in evidence. Mr. Dreshfield was questioned relative to these bonds. He was asked if these bonds belonged to Mr. Carpenter, and stated that they were Carpenter's property and that Carpenter gave a check for the bonds. He was next questioned relative to 21 notes which he testified he received from Mr. Carpenter. These notes were signed by Mr. Carpenter in blank. Mr. Dreshfield

said that 14 of the notes were returned to Mr. Carpenter on Lincoln's Birthday and then told what use was made of the others. He testified that he had made a false statement to Mr. Carpenter, in regard to the purchase of certain diamonds, in order to get Mr. Carpenter to pay over money which was owing to Mr. Breidenbach. Judge Hough has overruled the exceptions and the demurrer to the petition in bankruptcy filed against Mr. Carpenter. The demurrer in the case of Mr. Dreshfield was overruled some time ago. Mr. Dreshfield filed an answer to the bankruptcy proceedings Tuesday of last week, in which he denies the acts in bankruptcy set forth in the petition. An adjournment in the examination in bankruptcy of Mr. Carpenter was taken until to-morrow at 2 p. m. William Lesser, receiver in bankruptcy, conducted the examination. Mr. Breidenbach, the petitioning creditor, was represented by Sol Oppenheimer.

A petition in involuntary bankruptcy was filed yesterday in the United States District Court, New York, against the American Sheffield Silver Co., manufacturers and shapers of silver-plated ware, First Ave. and E. 28th St., by Charles E. Miller, Joseph J. Zeiger and Herman R. Boissier. It is alleged that the company owes debts in excess of \$1,000. The claim of Charles E. Miller, \$1,300, is for salary alleged to be owing him as president of the company during January, February, March and April, 1908. Joseph J. Zeiger's claim of \$27 is for printing supplied by the Brown Green Co., and assigned to Zeiger. The claim of Herman R. Boissier, \$55.81, is for machinery and supplies delivered to the Charles E. Miller Co. in 1907, which debt was assumed by the alleged bankrupt.

Newark.

Louis Kramer has moved from 618 Washington St., Hoboken, to larger quarters at 130 Washington St.

The firm of Frank Holt & Co. has been incorporated under the laws of New Jersey to deal in jewelry with a capital of \$100,000. The incorporators are: Frank Holt, Charles J. Hochstetter and Sidney T. Holt, all of this city.

After robbing the Lenox Pottery, Trenton, N. J., for two years, by carrying away gold leaf valued at \$1,500, Louis Kroschwitz, a skilled decorator and trusted employe of the concern, was detected, last week, through an anonymous letter and arrested. Kroschwitz is an artist in the decoration of high grade ceramic and tile work. He was held for the Grand Jury.

An item in a local newspaper recently stated that Jones & Woodland, manufacturing jewelers, had secured another jeweler to take charge of the store which was to have been opened, May 1, by C. S. Sandford at Cedar and Broad Sts. This is pronounced absolutely untrue by Jones & Woodland, who state that they are not and were not financially interested in Mr. Sandford, and have no financial interest in the jeweler who will now open the store.

E. C. Ernstein, formerly in business at Parker, S. Dak., has moved to Nebraska City, Nebr.

Connecticut.

Joseph O. Elmer, superintendent of the factory of Landers, Frary & Clark, New Britain, attended the golden wedding celebration of his parents, held in Hartford, April 13.

M. J. Buechler has moved his stock into attractively furnished quarters at 48 Fairfield Ave., Bridgeport. Mr. Buechler has been engaged in business in Bridgeport for the past 18 years.

S. S. Reiss, optician, New Haven, is now settled in larger and newly furnished quarters in a new building at the corner of State St. and Grand Ave. He was formerly located at 96 Elliott St.

Robert M. Wilcox and his wife, Ella Wheeler Wilcox, who have been spending several months touring in the west and in the Hawaiian Islands, will arrive at the Bungalow, Short Beach, some time this week.

President Foster E. Harvey, of Harvey & Lewis, conducting stores in Hartford, New Haven and Springfield, acted as toastmaster at the eighth annual banquet of the Hartford Business Men's Association, at the Ailyn House, April 10.

Fifteen silverware prizes, competed for, April 17, at the annual State Shooting Tournament, at the New Haven Gun Club, attracted considerable attention when displayed in the show windows of the store of Samuel Kirby & Sons, New Haven.

Walter Camp, president of the New Haven Clock Co., New Haven, returned last week from a business trip which included Harrisburg, Chicago and St. Louis. Mr. Camp was one of the speakers at the Yale Alumni dinner, given recently in Harrisburg.

Harrisburg, Pa.

J. U. Kilmer, Hummelstown, this county, is improving his home in that town.

C. N. Ober, of Elizabethtown, and family, will shortly remove to Webster City, Ia., where Mr. Ober will engage in the jewelry business.

A meeting of the Lykens Valley Business Men's Association will be held at Elizabethville, this county, April 27. A banquet will close the convention.

The local police authorities have been requested to look for Leslie Snyder, a spectacle salesman, who has been missing from his home in Hagerstown, Md., for about two months.

The local police authorities are keeping a close watch for the spectacle swindler who swindled people in Lancaster County recently. It is stated that he was working in this direction.

Operations were commenced April 14 by the York Watch Case Co. in one department, the engraving. As fast as the quarters for the various other departments can be made ready they will be placed in operation. In a few days the company expects to be employing about 150 men.

These officers of the Huntingdon Business Men's Association were elected last week: O. M. Brumbaugh, president; C. H. Miller, vice-president; Howard L. Henderson, secretary, and J. C. Hazlett,

treasurer. The present board of directors were nominated and elected to serve another term.

Minneapolis and St. Paul.

F. H. Harm & Bro., 387 Robert St., St. Paul, recently sustained a small loss by fire.

L. C. Gaus and N. Waldin, of L. C. Gaus & Co., Minneapolis, have returned to their territories on the road. A. S. Flett, Chicago, is a recent addition to the office force of this concern.

Cohen Bros., Minneapolis, recently moved into their newly furnished store at 412 Nicollet Ave. The store, which is over 100 feet deep, is lined on both sides with polished mahogany and plate glass fixtures.

A. G. Tellner, a prominent retailer of Jamestown, N. Dak., was in Minneapolis last week purchasing a boat and other Summer equipment for his Summer cottage, located on a lake about 18 miles out from Jamestown.

F. G. Simpson, manager of B. F. Simpson & Co., Minneapolis, is making a trip through southern Minnesota and South Dakota. B. F. Simpson has left for an extended trip through Minnesota, North and South Dakota, Wisconsin and the copper country of Michigan.

B. F. Simpson & Co., Minneapolis, have moved from the fifth floor of the Lumber Exchange to larger quarters at 716-717 Lumber Exchange, a much more accessible location, directly in front of the elevators. Two large safes will be added to the office equipment and a complete line of watches will be carried. The territory covered will be enlarged and three traveling representatives will work from the office.

Pacific Coast Notes.

H. W. Cook, Antioch, Cal., has rented a storeroom in the new Dahnken building, in that city, and will move shortly.

Grace Nicholson, Pasadena, Cal., is giving a special exhibition this month of rare pieces of antique hand wrought jewelry, at 46 N. Robles Ave.

C. H. Bauer has bought an interest in the firm of Henry L. Amstutz & Sons, Napa, Cal., and will take charge of the optical department, which is being remodeled.

J. J. McEvoy, Kennett, Cal., has taken a two years' lease on a store in a new building on Railroad Ave., and will move at once from his present quarters in the Smithsonian building.

W. C. Guerth has moved into the quarters formerly occupied by Mason & Bay, Redlands, Cal. Mr. Guerth secured many of the fixtures and \$5,000 worth of stock from Manson & Bay.

The American Jewelry Co., Bakersfield, Cal., is about to remodel the interior of its store, so as to have more space for the manufacturing department. The salesroom will also be remodeled and furnished anew.

Thieves, April 16, broke into the store of James Over, Milford, Mass., and escaped with a large amount of jewelry. Before taking their departure the intruders set fire to the establishment, causing a loss of about \$3,000.

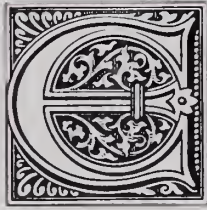

ENTERPRISING and successful jewelers everywhere are pushing the sale of some individual line of watches which they believe to be superior to all others, and upon which they can also make a satisfactory and justifiable profit.

This explains the growing demand for **ILLINOIS WATCHES**, in 0, 12, 16 and 18 sizes, by increasing numbers of leading jewelers throughout the United States.

If you are not familiar with the superior quality of—and advantages gained by handling—**Illinois Watches**, it will mean reputation and dollars for you to investigate.

Every one fully guaranteed.

Price List sent on application.

ILLINOIS WATCH COMPANY

SPRINGFIELD

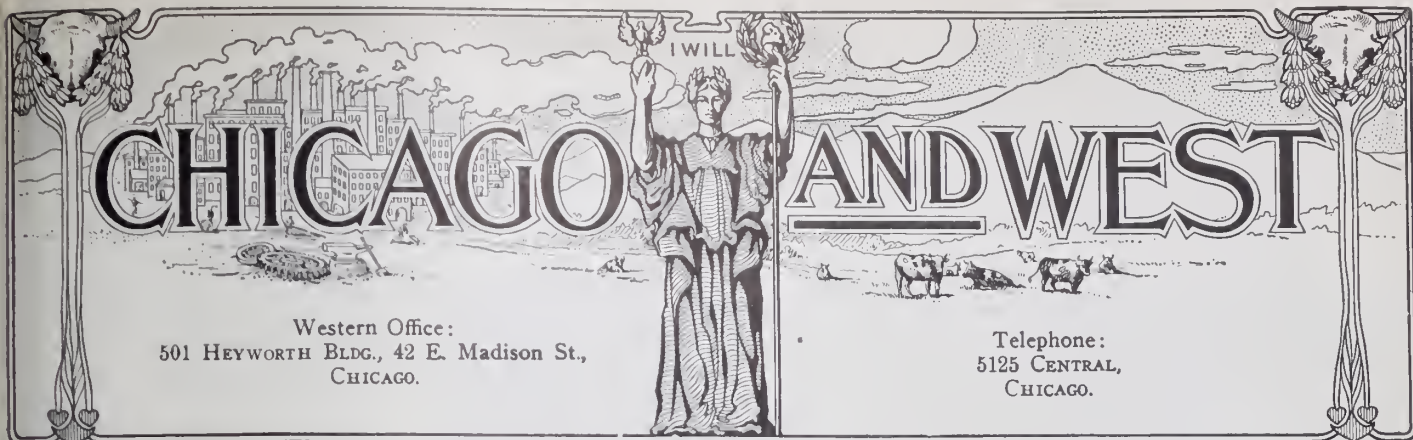

Western Office:
501 HEYWORTH BLDG., 42 E. Madison St.,
CHICAGO.

Telephone:
5125 CENTRAL,
CHICAGO.

Chicago Notes

Alfred Judson is on the jury this week.
Julius Ziegler is on a trip to the north west.

Henry C. Epstein has discontinued his Clark St. store.

Harry H. Miller is on a trip to St. Louis and Cincinnati.

Billy Lamb has returned from a 10 weeks' trip to the Pacific Coast.

A. Chouffet, with Heinz Bros., Buffalo, N. Y., is on a western trip.

"Sol" Kaiser and M. H. Berg are taking a vacation at French Lick Springs, Ind.

L. A. MacKown, with the Onida Community, Ltd., is back from Detroit, Mich.

E. L. Donaldson, with the Edwards & Sloane Jewelry Co., Kansas City, was here last week.

Ernest Critzer, of Critzer Bros., San Antonio, Tex., was here last week visiting friends.

H. Convisar has severed his connection with B. Schuette, jobber, in the Heyworth building.

Col. Keeler, of Chas. E. Graves & Co., is back from a long vacation at Tarpon Springs, Fla.

E. Craven, floor man for F. A. Hardy & Co., was married last Saturday to Miss Nettie Carter.

W. A. Burrows, jewelry jobber in the Heyworth building, has removed from room 1109 to room 801.

The court has ordered the receiver of the F. C. Happel Co. to pay the salesmen \$467 money due them.

The M. F. Barger Co. is moving from room 405, Columbus building, to room 900, Heyworth building.

C. H. Falch, optician for the Shourds, Adcock & Teufel Co., has removed to 80 Dearborn St., room 108.

A. V. Fray, formerly optician for Keil & Hettich, has gone into business for himself at room 910, 92 State St.

Otto Lieberman, with the Stein & Ellbogen Co., is on a trip through Wisconsin for the diamond department.

W. A. Burrows, E. D. Buell and S. Mills have been appointed appraisers for the bankrupt estate of Conrad Heegn.

Wm. La Rue, silverware buyer for C. D. Peacock, is in the German Hospital, where he recently underwent an operation.

Neal Vanderwolf, with the Chicago office of the Watson, Newell Co., is to be mar-

ried to-day to Miss Jessie Burrow, of Austin.

The Chicago office of the Rochelle Watch & Clock Mfg. Co. has removed from 64 Wabash Ave. to room 910, Heyworth building.

The family of Fred, Hyatt, Chicago manager for the Philadelphia Watch Case Co., has been increased by the advent of a baby girl.

Bert Salkin, 25 years old, was arrested in St. Louis, last week, charged with stealing jewelry from Jos. Brown & Co. over a year ago.

A meeting of the creditors of Max Marcus will be held April 28, at 10.30 A. M., before Referee Wean in the Monadnock block.

Geo. H. Thoma, who formerly had a jewelry store in Three Rivers, Mich., will soon open another jewelry store in that town.

Geo. Burnett, of Burnett Bros., Seattle, Wash., accompanied by his wife, stopped over in this city, last week, on his way home from the east.

A thief smashed a window in Hyman, Berg & Co.'s store one night last week, and was caught. Most of the jewelry stolen was recovered.

Ruth Wendell, daughter of E. V. Wendell, of the Western Watch Case Mfg. Co., was married, April 14, at the Hotel Metropole, to Sol H. Ganz.

Johnson Bros., department store proprietors, have added an optical department in charge of Chas. Stevenson, formerly with Marshall Field & Co.

A. Yaseen, 8755 Commercial Ave., preferred a charge of larceny, last week, against Joseph Majtus. The latter was sentenced to a year in the county jail.

G. P. Williamson, jewelry buyer for the Minneapolis branch of Butler Bros., was here last week. Arthur Evans, the Chicago jewelry buyer, is in the east.

David Strelitz, of Strelitz Bros., underwent an operation for appendicitis last week at the Michael Reese Hospital. Mr. Strelitz is reported to be doing well.

The "Camels" held their monthly dinner at Galli's last Thursday. It was a glorious success. The club, which has now 42 members, is limited to 50 members.

Mack A. Hurlbut and Ira M. Radabaugh stopped over in this city, last week, on business connected with the American National Retail Jewelers' Association.

Lapp & Flershem have moved from 195 State St. to 156 Wabash Ave. Eleven im-

mense safes were moved, nine of which were left on the street one night.

Briggs & Dodd closed Keil & Hettich's auction sale last Saturday. It ran seven weeks and was one of the most successful auctions ever conducted in Chicago.

A. E. Madsen, of Rettig, Hess & Madsen, accompanied by his wife and little daughter, will sail to-day (April 22) on the *Adriatic* for a three months' tour of Europe.

Geo. Weidig, Chicago manager for Jos. Fahys & Co., visited St. Louis and Kansas City last week. W. B. Harris, missionary, has just finished a trip through Iowa.

Samuel Cutler, S. Mills and W. A. Burrows, appraisers of the estate of the Shourds, Adcock & Teufel Co. have been awarded \$200 each for their services.

Dr. F. J. Van Kirk, Bellingham, Wash., stopped over here last week on his way home from Philadelphia, where he has been taking a post-graduate course in optics.

Louis Basch & Co., instalment jewelers in the Republic building, will move to 272 State St. on May 1. They intend to gradually drop out of the instalment business in Chicago.

H. S. Flower completes his auction sale of jewelry at 272 State St. on May 1, and will then vacate the premises. Mr. Flower intends to make a specialty of musical instruments in the future.

N. S. McGillivray & Co., 167 Dearborn St., have been incorporated under the name of the N. S. McGillivray Co., with a capital of \$2,500. The incorporators are N. S. McGillivray, Agnes Lamb and Jesse Lowenhaupt.

News is received here that Lang & Schlom have bought the fixtures and goodwill of Saul Klein, Greenville, Miss., and have embarked in the retail jewelry business at that place. They were formerly at Memphis.

F. C. Happel Co. are trying to make a settlement with their creditors so that they can take the matter out of court and continue in business. They have the good wishes of practically everyone interested in their attempt to have a speedy adjustment of their affairs.

The new corporation of the C. H. Knights-Thearle Co. has for its officers C. H. Knights, president; F. G. Thearle, vice-president and treasurer; J. P. Stewart, secretary. The management is the same as formerly. C. H. Woods and C. T. Gustafson are stockholders.

Alva Munson, who formerly was in the

We Can Increase Your Business from 25 to 100%

With a Catalog of your own, containing from 36 to 200 pages or over, arranged to suit your local conditions. Full particulars and samples on request.



STORE OF JOHN E. BONG, CORNING, N. Y.

(Extracts from letter.)

Pittsburg, Kansas, Jan. 6th, 1908.

The Arnstine Bros. Company,
Cleveland, Ohio.

Gentlemen:—We all know trade conditions at the time we expected to do business were entirely different from those existing at the time we made our contract. There was a big slump everywhere, the same as here, but our experience with the Catalog bears out the statement you made me as a trade getter. If it had not been for the Catalog and Circular advertising, our business, we do not think, would have been anything near what it was. From this time on, we believe we will feel the good effects of the Catalog. We are thorough believers in the personal appeal method of advertising, especially when Arnstine's Catalogs and Circulars are used.

Trusting this will find you enjoying a prosperous New Year, we remain,

Yours truly,

The Killam Jewelry Company,
Per Geo. Killam.

Used The Arnstine Bros. Co.'s Catalogs in
1904-1907.



STORE OF THE KILLAM JEWELRY COMPANY, PITTSBURG, KANSAS.

Our representatives visit nearly every State in the Union. If you are interested, and will notify us, our representative will take pleasure in calling on you and explaining our method.

THE ARNSTINE BROS. COMPANY

Originators of Our Exclusive Catalog Method for the Retail Jeweler

CLEVELAND, OHIO

IN WRITING US, PLEASE MENTION THIS ISSUE, "JEWELERS' CIRCULAR-WEEKLY"

Read Our Customers' Letters

(Extracts from letter.)

Corning, N. Y., Feb. 19th, 1908.

The Arnstine Bros. Company,
Cleveland, Ohio.

Gentlemen:—For three years I have had your Catalogs, and each year has shown a great improvement in business. Last year there came a new and mean competitor in our line of business, also two of our department stores carried a large line of jewelry, and when I consider the financial situation of late and my increase in business, believe that it is due to your Catalogs.

I shall take them again for next year and cannot help but recommend them to my fellow jewelers.

Wishing you a prosperous year for '08, remain,

Yours truly,

John E. Bong

Used The Arnstine Bros. Co.'s Catalogs in
1905, 1906, 1907.

jewelry business at Alexis, Ill., was here last week. Mr. Munson is looking for a good location to start a new jewelry store.

Frank Trewin, with the Keystone Watch Case Co., spent a few days here last week, looking over the market.

Mrs. Elizabeth J. Dessauer, after eight years of waiting, has secured a divorce from Simon G. Dessauer, who ran away with an actress and spent a term in State prison for converting to his own use \$30,000 worth of negotiable paper, the property of his mother-in-law. Dessauer was formerly the Chicago representative of the Mauser Mfg. Co.

The assets of Giovanni Faraco, bankrupt jeweler at 241 Milwaukee Ave., was sold at auction last week by order of the court. Faraco claimed \$400 worth of jewelry exemption. The stock sold brought \$774. The fixtures brought \$162 subject to a chattel mortgage of \$72. Deducting 10 per cent. for the auctioneer's charges there remains \$787, out of which the receiver's and trustee's fees must be paid. The bankrupt owed \$4,660.

Among the buyers in town last week were E. P. Sundberg, Fargo, N. Dak.; Charles M. Hunnicutt, Rockville, Ind.; B. Lewis, Buffalo, N. Y.; Perry Jackson, Rockford, Ill.; Arthur Rovclstad, Elgin, Ill.; Wm. D. Roeder, Dwight, Ill.; Al. Wuesteman, Champaign, Ill.; H. C. Pitz, Kalamazoo, Mich.; C. F. Graff, Elkhorn, Wis.; W. J. Graff, Boscobel, Wis.; Edwin W. Hicks, Albion, Ind.; Hugh Wagner, Lewiston, Mont.; C. V. Conyers, Oneida, Ill.

Harry Meyers, 29 years old, said to be a traveling salesman who eloped with Miss Leah Weil some weeks ago was held in bonds of \$4,000 to the Grand Jury, last week, on charges of larceny of a diamond ring valued at \$200 from Turner Bros. and a diamond ring valued at \$175 from Nordahl & Olsen. Meyers, it is charged, would go to a jewelry store and ask to see some diamond rings. He usually left without purchasing one, but after he had gone a ring would be missed from the tray.

The appraisers are at work on the Jos. Brown stock, and will probably finish their labors this week. The appraisal will amount to about \$100,000. In the face of this valuation, Brown's offer of 25 cents doesn't seem a very liberal one. He offers 10 cents cash, 10 cents in six months, and five cents in 12 months. The first meeting of the creditors is set for May 28, at 10.30 A. M., before Referee Eastman, room 905, Monadnock block. A trustee will then be appointed. In order to secure creditors on the 10-cent and five-cent notes Brown offers the indorsement of Max Weber, S. M. Jess and Ben Roth. It will be remembered that at the examination of Brown the name of Max Weber was frequently mentioned. S. M. Jess loaned Brown \$5,000 on merchandise, and Ben Roth, in addition to buying \$5,000 worth of jewelry from Brown a few days before the failure, also loaned Brown \$2,000 on merchandise. The hypothecated merchandise is still in the possession of Jess and Roth.

Grau & Co., Toronto, Ont., have completed arrangements to locate in Guelph. The concern will have quarters on Norfolk St.

Denver

T. Sorensen, of this city, is trying to make a settlement with his creditors.

N. W. Shapiro, formerly of Salt Lake City, has opened a new store at 16th and Larimer Sts.

I. O. Glazier, Greeley, Colo., has been in this city for a few days, making several large purchases.

Dan S. Park, Cheyenne, was in this city during the past week, looking after his business interests here.

T. V. Sherman, formerly located in the east, now has a store in Colorado Springs. He was in this city last week buying stock.

Other out-of-town jewelers here last week included C. R. Bunty Johnstown; E. R. Hisker, Pueblo, and C. J. Norse, Walden, Colo.

A. C. Almeida, Sugar City, Colo., mysteriously disappeared recently. The police are searching for him, and a speedy arrest is expected.

Joseph I. Schwartz, of the Schwartz Jewelry Co., is just recovering from a serious illness, which confined him to his home for three weeks.

Charles H. Brink, formerly manager of the Boyd Park Jewelry Co., has bought the stock of Mr. Sorensen, who filed a petition in bankruptcy a few weeks ago.

Carter & Son are opening a new store in Greeley, Colo. They have been in the city for the past week buying fixtures and goods. The store will be open about May 1.

Henry Wade, a colored porter with the Boyd Park Jewelry Co., died last week. He had been porter for the concern for 18 years. He had made many friends by his genial disposition and strict honesty, and news of his death was heard with much regret.

Omaha.

The H. J. Penfold Co. has recently installed a new workroom outfit for optical work.

Wm. J. Hickey, with E. Kirstein Sons Co., Rochester, N. Y., spent a few days recently in Omaha.

J. C. Grassburg, watchmaker for Abraham Mandelberg, is confined to his home on account of illness.

Sol Bergman was compelled to postpone his trip to the Black Hills last week, owing to the illness of his wife.

George W. Ryan, of the Mawhinney & Ryan Co., left last week on a business trip to New York and other eastern points.

Thieves entered the home of John Arnoldi by way of a second-story window last week and stole a fine watch and some valuable jewelry.

W. B. Graves, Elkhorn, Nebr.; Mr. Mapes, Craig, Nebr., and J. B. Hayden, Blencoe, Ia., were in this city last week, purchasing stock.

Gov. George L. Sheldon was informed, April 15, of the first arrest made in Nebraska for violating the optometry law. M. J. Strauss, an itinerant optician who was practising optometry at Trenton, Nebr., without a license, was notified of the violation, and upon his positive refusal to comply with the law, was arrested and fined \$25 and costs by Justice of Peace Taylor.

Cleveland.

Webb C. Ball has returned from a week's trip through the east.

Mr. and Mrs. A. T. Hubbard and family left for San Francisco Wednesday evening.

W. C. Cook, sales manager for the E. Howard Watch Co., was in this city Wednesday.

C. J. McCormick has opened quarters in the Schofield building, where he will give special attention to watch repairing, trade work, etc.

Among the retail jewelers in town in the past week were: F. D. Cramton, Burton, O.; F. H. Woodworth, Jonesville, Mich., and O. G. Carter, New London, O.

The Chicago, Peoria & St. Louis Railroad Co. has adopted the Ball system of time service, and H. L. Mowatt has been installing it during the past 10 days.

The Cleveland Watch Case Co., of which A. B. Shannon is manager, announces the opening of a shop at 746 Euclid Ave., devoted exclusively to the repairing of watch cases.

The Solomonson Optical Co. is putting in a new double window front of bevel plate glass. The upper part is of prism glass, which gives their establishment a very light and cheery appearance.

C. L. Robertson, on account of ill health, will leave Burt, Ramsay & Co., going to the more congenial climate of Jacksonville, Fla., where he is to be associated with the Greenleaf & Crosby Co.

A representative of the Michigan Association of Retail Jewelers spent several days here, last week, in the interest of their souvenir programme, to be published in connection with the meeting to be held in Detroit next June.

Walter E. Cadwood, a diamond setter, 23 years old, of 1245 E. 82d St., died suddenly last Wednesday night of heart failure at his home. Mr. Cadwood returned home from his work at noon complaining of not feeling well. Growing worse his mother sent for a physician. Before the physician arrived Cadwood was dead.

Jewelers' windows have held their own in attractiveness amidst the general Easter display during the past week. The Cowell & Hubbard Co. brightened up its window with Spring flowers. The Webb C. Ball Co. had a very attractive showing of amethyst jewelry grouped about a large cross of lavender silk. H. W. Beattie showed crosses, crowns, etc., arranged of unmounted diamonds, emeralds and rubies.

There has been much interest locally during the past 10 days in Congressman Vreeland's bill to regulate the stamping of gold filled cases. A letter strongly commending Congressman Vreeland's measure, and addressed to Hon. James Kennedy, chairman of the House Committee having this bill in charge, was circulated in Cleveland last week. Thirty-four legitimate retail jewelers were called upon in the short time at the disposal of the committee, and 33 signed up immediately. Such a preponderance of favorable sentiment indicates the popularity of the measure with local jewelers.

The Weber Jewelry & Music Co., Foley, Minn., has closed out there and moved the stock to St. Cloud, Minn.

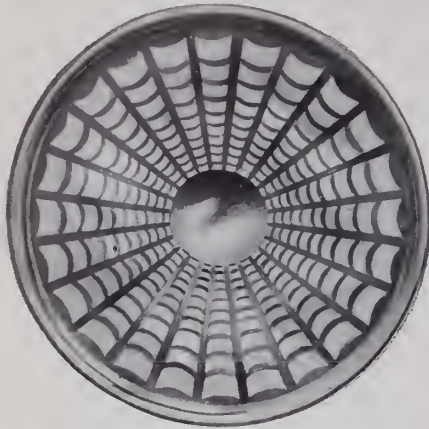

4844—4½", 5½", 6½", 7¼", 8½", 10", 12"

PLATEAUX

are one of the most popular articles in Sterling Silver this season for Easter and Wedding Gifts.

Sizes, 4 to 14 Inches

Prices - - \$3.00 to \$50.00 Each



4747—7¼"

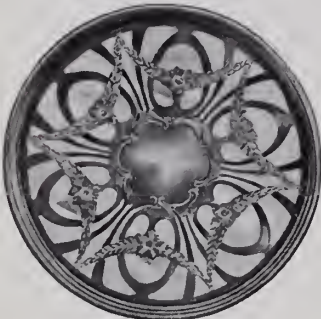

4734—4½", 5½", 6½", 7¼", 8½", 10", 12"



Frank M. Whiting & Co.

SILVERSMITHS

NORTH ATTLEBORO, MASS.

320. Fifth Avenue, New York

C. H. KNIGHTS

F. G. THEARLE

C. H. KNIGHTS & CO.

Columbus Building :: :: Chicago, Ills.

announce to the trade the incorporation, under the laws of the State of Illinois, of their

Wholesale Watch, Jewelry, Diamond and Material Business

under the name and style of

C. H. KNIGHTS - THEARLE CO.

C. H. KNIGHTS, President

F. G. THEARLE, Vice-President and Treasurer

J. P. STEWART, Secretary

The management will continue as heretofore, with the addition of Messrs. C. H. Woods and C. T. Gustafson, who have been with us many years and who now are stockholders. In closing the old firm name we wish to thank our friends for favors shown, and assure the trade that we will appreciate all future business with which we may be intrusted. Yours very truly,

C. H. KNIGHTS & CO.

Detroit.

E. H. Pudrith is in the east on a short purchasing trip.

I. W. Friedman, New York, called on the trade here recently.

Hugh Connelly and family spent their Easter vacation at Tilsonburg, Ont.

C. A. Watkins came in from Pontiac to attend the opening ball game last week.

Wm. Friedman, an attorney, has been named as trustee for the creditors in the bankruptcy proceedings against Samuel Stern.

E. R. Albaugh, Hillsdale, was married recently and spent a portion of his honeymoon in Detroit, stopping at the Hotel Pontchartrain.

E. F. Hill, salesman for Noack & Gorenflo, returned last week from an extended trip, and reported business throughout the State as improving.

A number of jewelry firms have had their personal property assessments raised this year by the board of assessors, which has been unusually active.

Adolph Enggass was one of the star rooters at the opening of the baseball season at Bennett Park. He has been at every opening for the past 23 years.

R. J. F. Roehm & Co. began moving their manufacturing business from their old site to the new location in the University building, on Monday. The retail department will remain in the Woodward Ave. store until the last of the month.

Fred J. Binder, of the Detroit Jewelry Mfg. Co., is a great baseball fan, and it is his endeavor at present to get up a baseball league with teams from the various firms in the Jewelers' Board of Trade. It is thought that there is enough talent for a six-club league.

Among the out-of-town jewelers who were in Detroit last week were: R. G. Allison, St. Johns; J. W. Switzer, Disco; C. G. Draper, Plymouth; J. P. Walton, Durand; W. E. Green, Mt. Clemens; A. E. Miller, Belleville; A. Munger, Caro; H. E. Meldrum, John Turck and Louis Krebs, Wayne.

Robbers broke into the store of John Hellerich, 510 Gratiot Ave., last Wednesday night, and stole jewelry valued at \$75. The police were immediately notified as soon as the robbery was discovered. James Sullivan and John Connors were arrested by Detectives Golden and Bandemer. They had been peddling jewelry and were taken while trying to dispose of rings in a saloon. When arraigned before Justice Jeffries the two men pleaded not guilty and their examination was set for April 21. Practically all the goods were recovered.

The joint committee from the Jewelers Board of Trade, Wholesalers' Association and Hardware Dealers' Association, which has in charge the mid-summer buyers' excursion, met Thursday evening in the Wholesalers' Association rooms, 92 Griswold St., and considered entertainment plans. It was decided to have one day of the five devoted to a lake and river trip on a steamer to be chartered for that purpose. Another evening will be spent at one of the local amusement parks, and there will also be an evening gathering in the Detroit Opera House, at which there will

be a lecture on economic topics, such as the parcels post. Frank Kennedy, of the Jewelers' Board of Trade, is one of the finance sub-committee, while R. E. Rogers, A. E. Patterson and A. E. Charlesworth are on the entertainment committee.

Cincinnati.

Hess Henle, of the M. Schwab Jewelry Co., left, this week, on a business trip.

Hugo Lindenberg, of Lindenberg & Fox, is home from a business tour in the south.

R. G. Maas, of A. A. Spiegel & Co., is ill with pneumonia at his home in Mt. Vernon, O.

E. B. Jacobs, of D. Jacobs & Co., will leave, this week, on his regular business trip through Ohio.

Arnold Brandley, Elkins, W. Va., stopped off here on his return from a three months' tour of the south.

B. S. Newman, of Frohman & Co., leaves to-morrow, April 23, with Mrs. Newman, on his European tour.

Julius J. Schaeppi, watchmaker for Joseph Mehmert, is reported to be very ill after an operation for appendicitis.

C. C. Cardon, Glasgow, Ky., was here buying the opening stock for a new retail jewelry and repair store.

Frank Herschede, of the Frank Herschede Co., and his wife left, last Monday, for New York on a business and pleasure trip.

Lee Loeb, of Herman & Loeb, has returned from an extended western trip, and reports business to be good beyond his expectations.

Joseph Noterman, of Joseph Noterman & Co., has been reappointed Waterworks Commissioner of Covington, Ky., for another two years.

C. L. Mellott, Woodsfield, O., stopped over in this city on his return from a pleasure tour of the west, which included the Pacific Coast and Texas.

Miss Lydia Cordon, recording clerk for Richter & Phillips, has severed her connection with this firm, and will be married to Harry Lang, of this city, in June.

S. C. Bingamin, formerly of Boston, but the last few months located here, has leased the storeroom lately occupied by Charles E. Levi, diamond dealer at 5th and Vine Sts., and will open a diamond business under the name of "The Crown." Mr. Bingamin has greatly improved these quarters by putting in a new glass front and adding many other new features. He expects to open for business about May 1.

Clarence Prentiss Tiller, who has served time for mail-box robberies, and who was recently reindicted for having robbed the Michie Bros. jewelry store in 1891, the old indictment having been quashed, filed an affidavit last week through Attorney Raymond Ratliff, in which he declares that at the time of the robbery he was living on Laycock St., Allegheny, Pa.

The Gustave Fox Co., last week, won suit for \$1,000 brought against one of the largest manufacturing and jobbing houses in Pittsburg, Pa., for alleged infringing of the Fox patent on the Order of Owls emblem pin. The Fox Co. was granted a judgment of \$500 damages, and also given permanent injunction against the defendants, prohibiting any further infringement.

Milford Fox, of this company, has just returned from Dallas, Tex., where he secured a \$15,000 contract for Elk emblem goods.

The out-of-town jewelers here during the past week purchasing goods included: H. I. Scribner, Columbus, O.; J. C. Meyer, Harrison, O.; Chase Hoffman, Arcade Jewelry Store, Springfield, O.; Frank Emmerling, Hillsboro, O.; O. C. Beer, Sunman, Ind.; "Dan" Bacharach, Central, O.; P. D. Freeman, Ashland, Ky.; T. L. Candel, Frenchburg, Ky.; F. L. Horning, Brookville, Ind.; William H. Grosse, Dayton, O.; H. S. Freelan, Seaman, O.; J. N. Embrey, North Lewisburg, O., and Mrs. M. A. Selbert, Frankfort, Ky.

Milwaukee.

Milwaukee jewelers are much wrought up by the frequency and boldness of thefts in their establishments. For six months hardly a fortnight has passed without a window robbery. A man giving his name as Thomas Cunningham entered the store of Richard Seidel one day last week and asked to be shown some diamonds. He selected a \$60 stone. He asked for pen and ink and wrote a check for that amount on the First National Bank of Milwaukee. While he was waiting for the package, the Seidel employes kept the wires between the store and the police station and the bank hot. When Cunningham turned he faced Dennis Sullivan, detective. The bank reported that Cunningham had no account and was totally unknown to them. The man is now in jail awaiting a hearing. His record is being investigated.

Yesterday morning, April 21, there were scheduled to be re-erected a half dozen street clocks, which were so ruthlessly torn down in the dead of night during March. On Tuesday, April 21, David S. Rose, for the fifth time mayor of Milwaukee, again assumed office, succeeding Sherburn M. Becker, by whose orders the clocks were removed. Archie Tegtmeier, a prominent South Side jeweler, said: "I talked with Mr. Rose personally and so have other members of the Jewelers' Club, and he assured me that we could put up our clocks again the minute he became mayor. If you will inquire you will find that all the jewelers who had enough of the clocks left to allow them to be repaired have fixed them up and have everything in readiness for putting them in place again. I think it was a fool trick to tear them down, and that the public at large looks upon the incident in that light. We shall put the clocks back as an accommodation to the people of the city."

Word was received from Des Moines, Ia., recently, to the effect that Grant Van Horn, a retail jeweler and optician, who had a store in the Capital State Bank building, that city, was in financial difficulties, and that his store had been closed by order of the bank officials, who held a first mortgage on his property. Mr. Van Horn has been in business previously in various lines, and succeeded to the business of the late Ole Olson in January, 1906. He is a practical watchmaker of ability, and in addition to a good repair business carried a stock of about \$2,500 until recently.

New Universal Three-Jaw Chuck

Self-Centering Drill Step
and Bezel Chuck

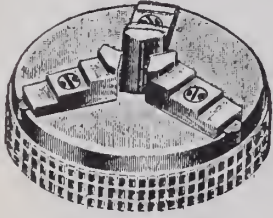

This New Universal Chuck with Reversible Jaws is the most practical on the market. Outside diameter 62 mm. (2½ inches). Capable of holding drills and wire from smallest up to 10 mm. Discs from 6 to 58 mm., and Bezels from 12 to 65 mm.

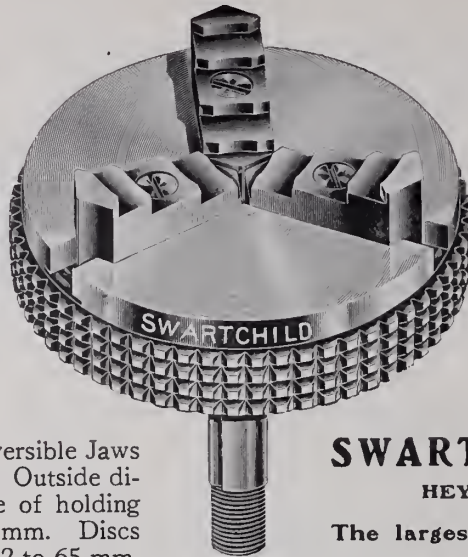

No. D 58—Mounted to fit Webster,
Whitcomb and Moseley No. 2.
Price, each - - \$9.00

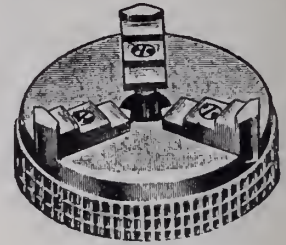

If you have not a copy of our double-sized, 440-page Catalogue, write at once. Sent gratis upon application.

SWARTCHILD & COMPANY

HEYWORTH BUILDING, CHICAGO

The largest exclusive jewelers' supply house
in the world

WM. C. PENFOLD CO.

No. 35 MAIDEN LANE, NEW YORK

LARGEST EXCLUSIVE WATCH JOBBERS IN NEW YORK OF

Dueber-Hampden Watches Dueber Cases—Hampden Movements

A Complete Line Always on Hand. Mail Us Your Orders

JOHN F. TURNER

Expert Jewelry Auctioneer

2 Maiden Lane, New York, N. Y.



My special field is high-class trade. As a connoisseur in fine Jewelry, Bric-a-Brac and Art Goods, I have conducted most successful sales for the largest houses in the trade, chiefly in the big cities and towns.

My plan of sales is especially adapted to such high-grade stocks, and has been perfected by twenty-five years of experience in this field.

I can guarantee absolutely a profitable sale, provided the character of the jeweler and his stock is such as to entitle him to my services.

Indianapolis.

E. M. Craft, of the A. P. Craft Co., was in Danville, one day last week.

It is feared that Harry Reed, who has been seriously ill for some time, will have to go to Chicago, where he will be attended by a specialist.

Charles Lünebein, formerly with William Weickmann, on S. East St., has taken a position with Don A. Hickman, a local manufacturing jeweler.

The Indianapolis Retail Jewelers' Association has adopted the plan under which persons seeking to have the value of jewelry estimated will have to pay two per cent. commission with a maximum fee of \$1.

J. L. Hastings, Sheridan, Ind., has been fined at Noblesville for practicing without a license. This is the first case that has been tried under the recent Indiana optometry law. Hastings first appealed to the Circuit Court and then withdrew his appeal.

Burton & Co., who, for the last 15 years, have been located at 11 N. Meridian St., will move about June 1 to 58 Monument Pl. They will have an excellent location in the building recently vacated by the Indianapolis Star. The firm will instal new fixtures and enlarge its stock.

H. E. Woodard, an optician of this city, who has been located at 221 Massachusetts Ave., for some time, has announced that he will move, June 1, to Room 307, in the new I. O. O. F. building, corner of Pennsylvania and Washington Sts. Mr. Woodard is president of the Indiana Optical Society.

Arrangements have been made by the Ontario Silver Co., located in Normal City, a suburb of Muncie, to receive its power during the next five years from the station of an electric light company. The company threatened to leave Muncie because it was unable to get railway service for its coal.

Several Indiana jewelers were in this city last week. Among them were: R. C. Eisenbach, Lafayette; F. C. Sheldon, Shelbyville; A. H. Pauley, Bloomington; W. W. Dale, Sullivan; J. F. Harding, Brownsburg; J. W. Hudson, Fortville; N. W. Myer, Crawfordsville; H. S. Wernecke, Greencastle, and Mr. Turner, Sr., of Turner & Son, Arcadia.

It is reported that the Ravenwood Watch Co., Chicago, will build a factory at Mishawaka and that it will have a site of 79 acres on which to erect a plant at a cost of \$100,000. It is understood that the buildings to be erected will include an office building 30 by 40 feet, three stories high, and a four-story building, 30 by 200 feet. It is intended to have the plant ready for occupancy about Aug. 15.

Several hundred dollars have been turned over to a local orphan home as the result of a card party, given on the afternoon of April 11, by Mrs. J. P. Mullally, wife of the president of the Indianapolis Retail Jewelers' Association. It was given at the German House, several hundred women attending. Thirty-seven pieces of jewelry were given. The donors were as follows: S. C. Powell & Co., loose diamond; Cohen & Abraham, loose diamond; S. B. Champion, locket and chain; L. Guttman &

Son, bracelet; Leo Heilburn, gold pins; Allsopp Bros., signet ring; L. H. Keller & Co., brooch; Kohlmeier & Johns, turquoise pin; A. P. Craft Co., cameo brooch; Baldwin-Miller Co., cut glass dish; Richter & Phillips, back comb; Hoffman & Lauer, hat pin; H. C. Schergens, cut glass dish and J. P. Mullally, two rings and four bracelets.

Kansas City

TRADE CONDITIONS.

A Kansas City jobber has just received reports from dealers throughout the Kansas City territory, answering a list of questions in regard to business conditions. Judging from these replies, which have been classified by States, the only territory in this section which is not enjoying a very good business for the season is Colorado and New Mexico. Reports from that section indicate an unusual dullness, with the exception of such sections as are irrigated. All the balance of the territory is making exceptionally encouraging reports.

Leslie White, with the Ward & Crellm Jewelry Co., was here last week.

L. Randazzo, 121 E. Missouri Ave., has just engaged in the jewelry business.

Sam Bloom, with the Meyer Jewelry Co., was in this city, last week, filling up his trunks for another trip.

A delegation of Kansas City jobbers and manufacturers left Saturday night to attend the Oklahoma convention.

W. C. Schumann, traveler for C. B. Norton Jewelry Co., was in the city, last week, taking the 32d degree in Masonry.

Chas. Moll, with A. Y. Boswell, Tulsa, Okla., was in Kansas City, last week, visiting friends in the jewelry trade. He was formerly located here.

H. W. Westley, pupil of the Missman School of Watchmaking and Engraving, has started for New Mexico, where he expects to locate, on account of his health.

Victor Lichtig, formerly of the Keystone Jewelry Co., in this city, and who moved with them to Los Angeles, Cal., is in the city again, visiting with his friends.

Floyd Crawford, who at various times has been with several of the Kansas City jewelry jobbing concerns, and who went to Arizona for the benefit of his health, is now in Sheffield, Tex., and reports that he is improved in health.

C. P. Kionka will hereafter make his headquarters in Chicago, where he will be more centrally located, and can reach the larger number of his customers with greater promptness, but he will still not neglect making his regular calls on the trade in the southwest. E. Kionka will, as heretofore, have full charge of the Kansas City office of Kionka & Kionka, and will take care of the mail order department of their business.

The following out-of-town jewelers were in this market last week: G. A. Carlson, Richmond, Mo.; Mr. Fraser, of Fraser & Cram, Leavenworth, Kans.; Geo. H. Spangle, Chetopa, Kans.; J. B. Bryant, Mound City, Kans.; H. W. Yaseen, Dalhart, Tex.; G. Willmann, Lawrence, Kans.; L. O. Kunze, Harrisonville, Mo.; Mrs. A. Rosenfield, Leavenworth, Kans.; Otto and Leslie Burkland, Moberly, Mo.; Chas. Morrison, Olathe, Kans.; L. D. Willitt, Hiawatha, Kans.; H. O. Woodbury, Olathe, Kans.; H. D. Lawrence, Dewey, Okla.; F. M. Dil-

lon, Bonner Springs, Kans.; J. H. Whiteside, Liberty, Mo.; E. F. Douglas, Dysart, Ia.; A. Rosenfield, Leavenworth, Kans.

Los Angeles.

John F. Boes, Salt Lake City, is spending some time here on a business and pleasure trip.

Mrs. J. C. Fleming, of the J. C. Fleming Co., who has been critically ill, is again able to visit the store.

J. P. Tate, head salesman for Edward Gerson, has been taking a vacation, spending most of his time at Riverside, Cal.

J. C. Peers, of the firm of Joseph C. Peers & Son, Rockford, Ill., is here with his wife making a visit of a few weeks.

Fred Roth, representative of M. Schussler & Co., San Francisco, with his wife and two nieces, has been spending a week or two in Los Angeles.

Sebastian Simmons, 315 S. Spring St., now intends to go to his Moqui-Aztec turquoise mine to begin active operations about May 1. He reports an increased demand for turquoise.

Mrs. Fleming, principal proprietor of the J. P. Trafton Co., who has been confined to her home by a painful affection of the ear, has now fully recovered and is again able to visit the store.

Louis Burger, manager of the Thos. B. Clark store, announces his intention of discontinuing the jewelry business and vacating the store at 251 S. Spring St., May 1. It is his purpose to store his stock until it can be disposed of.

Leonard S. Lee, of Gilmore & Lee, wholesalers, has returned from a fairly successful business trip to San Diego. He was present in that city at the time of the great demonstration on the arrival of the Atlantic fleet in American waters.

Percy H. Greer intends to return to San Francisco to reside as soon as he can sell his home here. He will again have his office at 717 Market St., with Morgan & Allen, with whom he had his headquarters for 14 years before the big fire.

E. Grelek, a watchmaker who has been doing business for the trade at 342 S. Broadway, has purchased the jewelry business of E. T. Willis, in Hollywood, a suburb of this city. Mr. Willis, who was formerly a traveling salesman, is not in the best of health, and finds the confinement of the store too trying for him.

Brock & Feagans furnished the invitations for the ball recently given to the officers of the fleet at Hotel Potter, Santa Barbara. Admiral Evans is reported to have pronounced the invitations the handsomest that he has ever received. At the top of each sheet is a piece of mother-of-pearl work $1\frac{1}{4}$ by $\frac{3}{4}$ inches, on the middle of which is a representation of a battleship in white. Below the ship the color is a deep blue, to give a water effect, and above a light blue for sky effect. The lettering is embossed. The same concern is displaying some fine stationery with the Los Angeles official flag at the top.

Grant Van Horne's store in Des Moines, Ia., has been closed on a mortgage. The stock will be invoiced and disposed of by the Capital City Bank.



Mr. Epstein, of the Epstein Watch Co., Chicago, was in San Francisco, Cal., recently.

W. A. Brouen, of Carter, Howe & Co., called on the trade in Denver, Cal., last week.

H. Reichman, of Jos. Fink & Co., called on the trade in Denver, Colo., about a week ago.

Joseph Meeker, with the Alvin Mfg. Co., New York, was in San Francisco, Cal., about a week ago.

Flint Bowen, of the Shepperd Mfg. Co., Melrose Highlands, Mass., visited the trade in Denver, Colo., during the past week.

Included among other traveling representatives visiting Toronto, Ont., lately, were: E. H. Mower, James Dixon & Sons (Sheffield, Eng.); C. P. Stouffer, J. H. Stouffer Co.; W. H. Sparks, Seth Thomas Clock Co.

J. J. McGary, of McGary's Universal Silver & Jewelry Polish Co., Denver, Colo., started, last week, on a three months' trip calling on the trade in Nebraska, Kansas, Missouri, Iowa and Illinois.

Among traveling representatives who called on the Ontario trade, last week, were: George B. Kenrick, Reed & Barton; John Blair, Blair Fountain Pen Co.; J. W. Armbruster, Illinois Watch Case Co.

Among the travelers visiting Boston, Mass., during the week, were: James W. Wortz, C. Sidney Smith & Co.; E. M. Knapp, J. A. & S. W. Granberry; Charles Theurer, Crane & Theurer; L. Henry, Jurgenson, Snow & Westcott Co.

Traveling representatives in Denver, Colo., last week, included: Mr. Wood, Rogers & Son; Norman Straus, Jacob Strauss & Sons; Wm. Arnold, Western Clock Mfg. Co.; Sidney L. Bauman, Sidney L. Bauman Co.; Morris Bauman, Bauman Bros. & Co.

Traveling representatives in Los Angeles, Cal., recently, included: Henry Jacobson, Jacobson Bros.; Max Bauman, Max Bauman & Co.; C. Beckwith, Jos. Fahys & Co.; George Smith, Keystone Watch Case Co.; Herbert Reichman, Joseph H. Fink & Co.; Richard F. Armstrong, Bippart, Griscom & Osborne; John O. Slemmens, J. B. Bowden & Co.; George F. Miller, Gorham Co.

The following traveling representatives visited the trade in Lancaster, Pa., recently: Joseph D. Varley, Allsopp Bros.; C. G. Walker, Pairpoint Corporation; F. Van Olinda, New England Watch Co.; W. T. Francis, Waterbury Clock Co.; C. E. Hunt, Shafer & Douglas; A. Ed. Fisher, L. Kroll & Son; T. E. Jacobus, Bride & Tinkler; G. E. Melville, D. Wilcox & Co.; Wm. H. Kopf, L. H. Keller & Co.; Mr. Hllington, American Silver Co.

The following traveling representatives called on the trade in Kansas City, Mo., last week: G. W. Curceton, Henry G. Lefort; F. D. Newburger, Chas. Keller & Co.; George Goldberg, Untermyer-Robbins Co.; F. E. Hyatt, Philadelphia Watch Case Co.; C. S. Wilson, New York Standard Watch Co.; E. E. Stockton, E. Ingram Clock Co.; C. T. McKenna, Kelly & Steinman, Inc.; M. H. Mason, James E. Blake Co.; Walter S. Strauss, Jacob Strauss & Sons; L. W. Arnold, Western Clock Mfg. Co.

Traveling representatives in Omaha, Nebr., during the past week, were: A. Pretzfelder, L. W. Levy & Co.; Thomas E. Rogers, Riker Bros.; F. R. Horton, Carter, Howe & Co.; W. S. Manheimer, Louis Manheimer & Bros.; C. Williams, Gorham Co.; John A. Lassou, Martin, Copeland Co.; Mr. Adams, Wm. B. Dugin Co.; W. L. Miller, Hodenpyl & Walker; C. H. Davidson, Kohn & Co.; A. F. Laute; Mr. Morchouse, Morehouse & Son; H. C. Ulmer, Meyrowitz Mfg. Co.; William Gregory, Strobel & Crane.

Among the traveling representatives who visited the trade at Pittsburg, Pa., last week, were the following: George H. Thomas, Edward Todd & Co.; H. N. Van Bergen, Snow & Westcott Co.; Charles L. Sexton, William L. Sexton & Co.; A. H. Colin, Eastwood-Park Co.; Mr. Harmer, Solidarity Watch Case Co.; Milard E. Heise, Langfeld Bros. & Co.; H. B. Bliss, Gorham Co.; J. W. McClannin, Wilcox Silver Plate Co.; Will-

iam Hoffman, Eichberg & Co.; J. C. Bigalke, Bigalke & Eckert Co.; J. F. Dean, Reed & Barton; R. H. Schley, Sloan & Co.; E. E. Stockton, E. Ingraham Co.; Fred H. England, Frolichstein, England & Klein; Fred D. Smith, Barstow, Kollmar & Co.

Traveling representatives who called on the Cincinnati, O., trade, during the past week, included: D. Zimmern, Zimmern, Rees & Co.; Mr. Gardner, E. A. Bliss & Co.; Maurice Kohn, Silbermann, Kohn & Wallenstein; J. F. Dean, Reed & Barton; Mr. Henderson, Crane & Theurer; David E. Jacobs, Wagner Comb Mfg. Co.; Charles L. Sexton, William L. Sexton & Co.; W. H. Gregory, Strobel & Crane; H. B. Bliss, Gorham Co.; C. A. Holbrook, Sloan & Co.; J. E. Pryor, Pryor Mfg. Co.; L. H. Smith, Bippart, Griscom & Osborn; H. N. Van Bergen, Snow & Westcott Co.; Mr. Singleton, Adams & Singleton; James R. Palmer, Henry A. Kirby; Mr. Bliss, Wordley, Allsopp & Bliss Co.; J. B. Carmichael, Bride & Tinkler; Arthur Totten, Sanshury & Nellis; T. H. Smith, Roger Williams Silver Co.; Mr. Fox, I. Guntzburger & Son; J. B. Macdonald, Wolcott Mfg. Co.; Ernest Block, Louis Stern & Co.; Mr. Simons, Simons, Bro. & Co.; J. A. Foulger, Gorham Co.; Fred H. England, Frolichstein, England & Klein, Inc.; Melvin Untermyer, Charles Keller & Co.

Toledo.

The Clinton Clothing Co. has eliminated its jewelry department.

The Sample Jewelry Store has just opened on Summit St., near Monroe St. A general jewelry business will be conducted.

D. A. McComb has opened a jewelry store at the corner of Monroe and Bancroft Sts., the store being in the most suburban part of the city.

L. Beckman, of the L. Beckman Co., 319 Adams St., accompanied by Mrs. Beckman, will leave April 21 for an European trip extending over several months. Oscar Beckman, a son, who is attending school at Cascadilla, will join his parents in Germany early in June.

Among representative Toledoans interested in a campaign for a new museum of art building for the city, are several jewelers, who have co-operated with the trustees and who have contributed largely to the building fund, among those interested being Norman E. Hascall, of J. J. Freeman & Co.; Louis Commlossy, L. Beckman and J. J. Vernier.

J. Geo. Kapp, Summit St. jeweler, is one of the leading members of the Retail Merchants' Board of the Toledo Chamber of Commerce, now being organized. Mr. Kapp is especially interested in having all the local jewelers belong to the organization, the object of which is to protect retailers from solicitors for personal and various charitable enterprises without proper credentials, the prosecution of shoplifters, the elimination of the present credit system and concomitant abuses. Another thing in which the organization is interested is the movement to secure semi-annual openings at the same time. Mr. Kapp represents Toledo jewelers on the membership committee.

P. L. Wilson, Deerfield, Kans., is now at La Jara, Colo.

A thief about a week ago made an unsuccessful attempt to break into the store of A. J. Heiman, Barberton, O. Mr. Heiman had arisen to start out on a hunting trip when he discovered the man trying to break in the back door. Several shots were fired after the thief, who succeeded in making his escape.

San Francisco.

Jno. T. Lowe, Hollister, Cal., visited this city, a few days, last week.

Mr. Canter, with Nordman Bros., is in from his regular trip through Southern California.

F. A. Conant, Santa Barbara, Cal., was here, recently, calling on old friends and replenishing stock.

Mr. Huggins, president of A. I. Hall & Son, left for the east, last week, in the interest of his firm.

Nordman Bros. are compiling a large material catalogue, which will be ready for the trade about June 1.

Ben Body, now city salesman for the Alphonse Judis Co., will call on the trade shortly, in that capacity.

W. H. Fulton, with J. B. Whitney & Co., has returned from a satisfactory trip through Southern California.

Peter Engel, Marysville, Cal., accompanied by his wife, was here, the first of the week, en route to San Jose, Cal., where he will spend a short vacation.

Alfred H. Bullion was married, Sunday, April 12, to Miss Alice B. Cohen. Mr. Bullion and his bride are spending their honeymoon in the Yosemite Valley.

The wholesale jewelers of this city have organized a baseball team, which promises to be a pennant winner. They have a series of five straight victories to their credit at the present time.

The California Watch Case Co., whose present store is at Larkin and O'Farrell Sts., is preparing to move, this week, to the Pacific building, at 4th and Market Sts., where attractive quarters have been secured.

Mr. Young, of the J. A. Young Co., is in New York at present in the interests of his firm. Mr. Plate, with this company, has just returned from his regular trip through the northern part of California, where he reports business quiet.

A. T. Lipman, a prominent traveling representative with the Morgan & Allen Co., this city, has been obliged to discontinue his traveling owing to illness. Mr. Lipman has been ill for some time past, but his family believe that with proper attention he will recover.

After May 15, Hammersmith & Co. will be installed in their permanent downtown location, the Hammersmith building, at the southwest corner of Grant Ave. and Sutter St. The present store at Van Ness Ave. and Eddy St., will be discontinued. The company is now holding a removal sale, and it is aimed to dispose of the entire stock before moving.

During the Easter season Ryrie Bros., Ltd., Toronto, Ont., sent out several original advertising cards and folders as a supplement to their regular newspaper advertising. One slip of paper, which was inclosed with other matter, showed a reproduction of a hand-painted violet sachet, printed in colors. Other slips, measuring 7¼ by 8¾ inches, showed beautiful half-tone reproductions of articles suitable as Easter gifts. These slips were printed in black and purple. A folder sent out by the same concern, entitled "Easter Gifts," and printed in brown and purple, showed an attractive line of Easter stock.

INDEX TO ADVERTISEMENTS.

Acme Comb & Novelty Co.....	30	Hammel, Riglander & Co.....	S. 19	Pitzele, S.	28
Alkin Lambert Co.....	31	Harris & Harrington.....	96	Potter & Buffinton Co.....	32
Alvin Mfg. Co.....	Inside front cover	Hedges, A. J., & Co.....	27	Prior, Charles M.....	27
American Gem & Pearl Co.....	56	Hedges, Wm. S., & Co.....	54	Pryibil, P.	100
American-Swiss Watch Co.....	96	Heller, L., & Son.....	46	Purdy, Chas. S., Co.....	52
American Platinum Works.....	108	Herpers Bros.....	100	Racine, Jules, & Co.....	84
American Watch Case Co.....	82	Himalaya Mining Co.....	48	Randall, C. Ray.....	17
Arch Crown Mfg. Co.....	31	Hodenpyl & Walker.....	50	Ranlett & Lowell Co.....	32
Arlzona Turquoise Mines Co.....	46	Hoffman Novelty Co.....	58	Reichhelm, E. P., & Co.....	100
Arnstein Bros. & Co.....	42	Hohenstein Co.....	106	Reichman, A.	50
Arnstine Bros. Co.....	72	Hold On Clutch Co.....	31	Renzihausen, W. F., & Co.....	108
Austin, John, & Son.....	109	Hotel St. James.....	104	Revell, A. H., & Co.....	107
Bagg & Co.....	52	Iraba, Louis W.....	102	Richards, J. M.....	46
Baker, Geo. M.....	100	Illinois Watch Co.....	70	Richards, W. E., Co.....	28
Ball, Webb C., Watch Co.....	97	Ingraham, E., Clock Co.....	96	Richardson, Enos, & Co.....	24
Barrows, H. F., Co.....	59	Irons, Joseph.....	102	Robbins, Chas. M., Co.....	33
Baschkopf, Henry.....	34	Irving Cut Glass Co.....	102	Robert, E. E.....	95
Bassett Jewelry Co.....	34	Jacot Music Box Co.....	104	Roger Williams Silver Co.....	29
Bates & Bacon.....	18	Janitschek Co.....	58	Rohrbeck, John E.....	29
Bedell, C. F., Co.....	82	Jeanne, F. A.....	52	Roseman, A.	58
Berge, J. & H.....	106	Juergensen, Jules.....	97	Rothschild Bros. & Co.....	27
Billings, Chester, & Son.....	50	Juzek, T. J., & Co.....	109	Roy Watch Case Co.....	97
Bishop, R. W.....	106	Kahn, L. & M., & Co.....	42	Rudolph & Snedeker.....	97
Blackinton, R., & Co.....	11	Keller Jewelry Mfg. Co.....	26	Rumpp, C. F., & Sons.....	106
Borrelli & Vitelli.....	56	Kent & Woodland.....	26	Saunders, Meurer & Co.....	54
Bowden, J. B., & Co.....	22	Ketcham & McDougall.....	51	Sessions Clock Co.....	97
Bradley Polytechnic Institute.....	97	Keystone Watch Case Co.....	90	Smith, Alfred H., & Co.....	46
Briggs, D. F., Co.....	16	Kirby, H. A.....	64	Smith, Frank W., Co.....	17
Bryant, M. B., & Co.....	22	Knights, C. H., & Co.....	74	Snow & Westcott Co.....	25
Carter, Howe & Co.....	25	Kohlbusch, Herman, Sr.....	100	Solidarity Watch Case Co.....	21
Chatham National Bank.....	66	Kohn, Alois, & Co.....	28	Spencer, E. L., Co.....	33
Chelsea Clock Co.....	96	Kremenz & Co.....	23	Star Watch Case Co.....	6
Chicago Art Metal Works.....	36	Larter & Sons.....	40	State Bank.....	66
Chopard Freres Co.....	28	Lederer, S. & B., Co.....	34	Steiner, Louis.....	104
Cottle, S., Co.....	25	Lees & Sanders.....	108	Stern Bros. & Co.....	52, inside back cover
Crees & Court.....	59	Lelong, L., & Bro.....	109	Stern & Corn.....	84
Crohn, M.....	35	Lewy & Cohen.....	29	Sternau, S., & Co.....	16
Cross & Beguelin.....	64	Lisner, D., & Co.....	21	St. Louis Watchmaking School.....	82
Crossman Co.....	58	Lorsch, Albert, & Co.....	42	Street, Geo. O., & Sons.....	25
Crouch & Fitzgerald.....	102	Loth, Joseph, & Co.....	32	Sussfeld, Lorsch & Co.....	102
Day, Clark & Co.....	27	Lowe, Edwin, & Co., Inc.....	31	Swartchild & Co.....	76
Deacon, Louis J.....	25	Mabie, Todd & Co.....	106	Title Guarantee & Trust Co.....	66
De Simone, F., & Son.....	59	Maintien Bros. & Elliot.....	36	Towle Mfg. Co.....	60
Dixon, Wm., Inc.....	108	Market & Fulton National Bank.....	66	Trout, Charles L., & Co.....	25
Doran, Bagnall & Co.....	32	Martin, Sam.....	110	Turner, John F.....	76
Dorfinger, C., & Sons.....	102	Mathey Bros., Mathez Co.....	106	Unique Art Glass & Metal Co.....	107
Draper, O. M., Estate.....	35	Mercantile National Bank.....	67	Untermeyer-Robbius Co.....	59
Dubois Watch Case Co.....	92	Merrill, S. K., Co.....	82	Urich, S.....	84
Dueber-Hampden Watch Mfg. Co.....	10	Miller, Fuller & Whiting Co.....	35	U. S. Smelting & Refining Works.....	109
Dunn, T. J., Co.....	29	Morstrom, W. G.....	50	Vacheron & Constantin.....	95
Durand & Co.....	24	Mount & Woodhull.....	52	Van Dam, Eduard.....	44
Eden, C. H., & Co.....	20	Murray, Dan I.....	107	Van Dusen & Stokes Co.....	20
Eichberg & Co.....	58	Myers, J. A.....	82	Wachenheimer Bros.....	35
Eisenmann Bros.....	50	Myers, S. F., Co.....	29	Waite-Thresher Co.....	36
Elgin National Watch Co.....	88	New England Watch Co.....	94	Waldron & Carroll.....	30
E. P. H. Chauv Catch.....	104	New York Tortoise Shell Co.....	104	Waltham Watch Co.....	86
Fahys, Joseph, & Co.....	3	Nissen, Ludwig, & Co.....	26	Washburn, C. Irving.....	35
Feldenhaimer, Louis.....	56	Noel, Randolph, & Co.....	44	Wells, Chester H.....	28
Fontneau & Cook.....	9	Omega Watches.....	95	Wendell & Co.....	7
Foster, Theodore W., & Bro., Co.....	38	Oneida Community, Ltd.....		Wheeler, Hayden W., & Co.....	44
Freeman, B. S., Co.....	32		13, 14, 15, outside back cover	Whiting & Davis.....	19
Freund, Henry, & Bro.....	22	Oppenheimer Bros. & Veith.....	84	Whiting, F. M., & Co.....	74
Garreaud & Griser.....	28	Oskamp-Nelting & Co.....	84	Whiting Mfg. Co.....	12
Gibson Building.....	106	Osmers-Dougherty Co.....	26	Wightman & Hough Co.....	30
Gillette Sales Co.....	37	Osmun-Parker Mfg. Co.....	24	Wittnauer, A., Co.....	96
Goldsmith, Leo.....	34	Ostby & Barton Co.....	18	Wittstein, Chas. T.....	31
Goodfriend Bros.....	54	Pairpoint Corporation.....	102	Wolfsheim & Sachs.....	30
Gorham Co.....	62	Papazien, A. D.....	97	Wollstein, L. & M.....	109
Greene, Wm. C., Co.....	34	Patek, Philippe & Co.....	94	Wood, J. R., & Sons.....	4, 5
Griffoul, August.....	100	Penfold, Wm. C., Co.....	76	Zarenbowltz, A.....	100
Gugenheim, M.....	29	Piteairn, W. S.....	104	Zimmern, Henry, & Co.....	109
Hagstoz, T. B., Ltd.....	108				

Special Notices.

Payable invariably in advance.

Rates 75c. per insertion for notices not exceeding 25 words; additional words, 2c. each.

SITUATIONS WANTED, 1c. a word each insertion; minimum charge, 25c.

Heavy type, 5c. a word; minimum charge, \$1.25. Display cards, \$2.00 per inch.

In all cases, if answers are to be forwarded, 10c. extra to cover postage must be enclosed.

All answers to advertisements addressed care *The Jewelers' Circular-Weekly*, should be sent to the New York Office, unless the Chicago Office is specifically mentioned.

Situations Wanted.

WANTED, position in jewelry store by first class engraver. Address "A. F., 3819," care Jewelers' Circular-Weekly.

JEWELER, order worker and first class repairer, desires position. Address "H., 3954," care Jewelers' Circular-Weekly.

A GOOD, all around jeweler desires position in store or factory. Address Robert Jourdan, 12 Mulberry Place, Newark, N. J.

POSITION desired by a gilder, capable of making all colors, understands polishing and lapping. Address "N., 3824," care Jewelers' Circular-Weekly.

FIRST CLASS watchmaker, with own lathe and tools, prefer a position in Greater New York. Address "L., 4067," care Jewelers' Circular-Weekly.

WATCHMAKER and jewelry repairer wishes position in south or west, at once; good reference. Address "B., 4044," care Jewelers' Circular-Weekly.

AT ONCE, by German, all around man, watchmaker, jeweler, engraver, stone setter, colorer, etc.; go anywhere. Lambert, 169 E. 128th St., New York.

CLOCKMAKER, age 21, good, all around man, desires position; have full set of tools and best reference. Address "J., 4066," care Jewelers' Circular-Weekly.

YOUNG MAN, 26, wishes position as stock clerk or inside salesman; 13 years' experience in wholesale and retail. Address "G. J., 4040," care Jewelers' Circular-Weekly.

YOUNG MAN, 9 years' experience in retail jewelry business, desires position in retail or wholesale house; willing to travel. "K., 4042," care Jewelers' Circular-Weekly.

YOUNG MAN wishes position as silver salesman or stock clerk; have four years' experience; can give the best of reference. Joseph Head, 94 Christopher St., New York.

YOUNG MAN, neat appearance, wishes position as salesman in retail jewelry store; five years' experience; A1 references. Address "T., 4009," care Jewelers' Circular-Weekly.

YOUNG MAN, 25, speaking German, English and French, well acquainted with jewelry trade, wants position, wholesale or retail. "X., 4055," care Jewelers' Circular-Weekly.

FIRST CLASS watchmaker, with tools, desires position at once; good references; competent to handle railroad work. Address "Watchmaker," 45 Charles St., Springfield, Mass.

SITUATION WANTED as assistant watchmaker; four years' experience on watch, clock and jewelry repairing; age 24, single; best references. Address F. Berger, Newark, N. Y.

WATCHMAKER of 20 years' experience on high grade watches, and accustomed to serve on high class trade, desires good position with first class jewelers. "M.," 22 Morland St., Roxbury, Mass.

ONE of the most thorough workmen in the south desires position with first class house appreciating fine service; can manage entire business. "Reliable, 3965," care Jewelers' Circular-Weekly.

YOUNG MAN, 24, desires position with wholesale jewelry firm; five years' retail experience; best references as to honesty and ability. Address "O., 4008," care Jewelers' Circular-Weekly.

SITUATION WANTED by first class manufacturing and jobbing jeweler, also stone setter and all around man, with best of references. Address "M., 4011," care Jewelers' Circular-Weekly.

YOUNG MAN, 20 years of age, having four years' experience in the jewelry business as clerk, desires a permanent position; best of references. Address "H., 4068," care Jewelers' Circular-Weekly.

HIGH GRADE, competent watchmaker, all around man, desires to make a change; 25 years' experience; A1 references. Henry Paulson & Co., Material House, Chicago, Ill., and San Francisco, Cal.

MANUFACTURING JEWELER, 32, married, first class on new and repair work, wants steady position; 18 years' experience; best of references; good habits. Wm. Vehs, 778 Hunterdon St., Newark, N. J.

YOUNG MAN, watchmaker, 24 years old, wishes a position in country or New York City; have good reference and own tools; wages, \$14 a week. Address F. Wolfberg, 36 E. 7th St., Oswego, N. Y.

WANTED, position as salesman or manager with retail jeweler; 15 years' experience; good references; married, 29; good address; just the man you want. J. P. Turner, 1729 Edmondson Ave., Baltimore, Md.

ENGRAVER, young man, desires position with first class engraver, or an opportunity to learn watch work; good script letterer; samples on request; A1 reference. "D., 3602," care Jewelers' Circular-Weekly.

FIRST CLASS jeweler on gold and platinum work, setter and plain engraver, an all around workman, wishes position in shop or factory; best of references furnished. Address "K., 3998," care Jewelers' Circular-Weekly.

SITUATION WANTED by a thoroughly high class watchmaker, jeweler and engraver; A1 stone setter; full set of tools; 28 years' experience with high class firms; references. "N., 4025," care Jewelers' Circular-Weekly.

TRAVELING SALESMAN; thoroughly experienced salesman, with unquestionable references, desires a factory line of gold jewelry, to travel between St. Louis and the western coast. Address "S. L.," 1112 Main St., Kansas City, Mo.

FIRST CLASS watchmaker, salesman and graduate optician; 21 years' experience; capable of taking full charge; 36 years old; American; have tools and trial case; state wages; A1 reference. Address "R., 4049," care Jewelers' Circular-Weekly.

WANTED, position by refracting and manufacturing optician; 15 years' experience; also fine engraver and expert jewelry and diamond salesman; do own edging, drilling, bending, adjusting; A1 references; correspondence solicited. "S., 4047," care Jewelers' Circular-Weekly.

WANTED, position as watch and clock repairer; can do some jewelry repairing; have had three years' experience and can give the very best of references as to character and work; prefer the States of South Carolina or Georgia. Address "M., 4063," care Jewelers' Circular-Weekly.

A1 WATCHMAKER, fine engraver and graduate optician, 23 years' experience; several years in present position as first man in large store; do not repair clocks or jewelry; would not go east of Indiana; \$18 to \$20; first class references. Address "S. J., 3862," care Jewelers' Circular-Weekly.

SALESMAN, intelligent, capable of handling any proposition; established trade in south, west and east, prefer middle west; manufacturer's line only considered; straight salary, or salary and commission; residence in Chicago; what have you? Address "Y., 4039," care Jewelers' Circular-Weekly.

JEWELER, ambitious, sober, conscientious, German-American, age 23, with seven years' experience with three reliable Newark firms on all kinds of 10-18 karat work, also general repairing, including watches and clocks, can polish and sand, desires position; well acquainted in eastern States; high school graduate; excellent references; sacrifice wages about \$15. Address "Investigate," 94 Bremen St., Newark, N. J.

Side Lines Wanted.

MANUFACTURER'S LINE of cut glass wanted for southeastern territory; representing one jewelry firm 15 years in this territory; have their permission to carry line; have permanent headquarters and able assistant. "O., 4053," care Jewelers' Circular-Weekly.

Help Wanted.

WANTED, at once, a graduate optician; must be good watchmaker. Address "A., 4030," care Jewelers' Circular-Weekly.

WANTED, watch case repairer; state age, experience and by whom you were last employed. Address Drawer No. 1127, Kansas City, Mo.

WANTED, first class watchmaker and engraver; wages, \$20 per week; regular job if satisfactory; give reference. The Little-Long Co., Charlotte, N. C.

WANTED, an experienced man who can do good watch work and nice engraving and is a good salesman; situation in New York State; good salary. Address "Jeweler, 3960," care Jewelers' Circular-Weekly.

DESIRABLE POSITION in New York City to competent American watchmaker and engraver, with ability as salesman; must have own tools and highest references. Address "N. Y. C., 4012," care Jewelers' Circular-Weekly.

WE HAVE a position open for a good, active, reliable man who understands the pawnbroking business thoroughly; must be a good salesman and understand values in general; salary no object; full particulars in first application. Goldwater's, 841 Broadway, Oakland, Cal.

AT ONCE, good, experienced watchmaker, one who is fair engraver and jewelry repairer; first class references from last employer and sample of engraving in first letter; position permanent and reliable; salary, \$20 per week to start; if satisfactory will raise. Address "R., 4065," care Jewelers' Circular-Weekly.

WANTED, men to earn \$25 to \$150 per day; others are now earning it, you can do likewise; if you desire to increase your salary and elevate yourself let us send you a book free, giving some valuable information how to become a professional auctioneer. Write or call at the Chicago School of Auctioneering, Dept. G., 816 Ashland Block, Chicago, Ill.

Business Opportunities.

RETIRING FROM BUSINESS; will sell my stock of high grade jewelry amounting to about \$2,000, or will trade for lots or diamonds. Rossi, 20 Maiden Lane, New York.

FOR SALE, best paying jewelry store in St. Louis, Mo.; invoice about \$2,500, 10 per cent. off; I am going back to Europe for good. A. Baujot, 2237 S. Grand Ave., St. Louis, Mo.

\$1,000 WILL BUY an old established jewelry store in South Brooklyn, N. Y.; a splendid opportunity for a good man; reason for selling, other business. Address "V., 4033," care Jewelers' Circular-Weekly.

FOR SALE, jewelry and musical store in best town of South Carolina; population 2,000, with county seat, 30,000; invoice can be reduced to \$1,500; repairs cover all expenses; best chance for right man. "S., 3908," care Jewelers' Circular-Weekly.

FOR SALE, jewelry business in good western New York village of 1,400; inventory, including stock, fixtures, etc., about \$2,600; good run of bench work and optical business; cash; dissolution in partnership. "N., 4046," care Jewelers' Circular-Weekly.

OPPORTUNITY; jewelry repair and mounting business, large, well established trade, for sale, coloring plant, motors, rollers and lathes in good condition; only those who wish to engage in business need apply. "A., 4057," care Jewelers' Circular-Weekly.

BEST LOCATION in Baltimore, opposite Washington and Baltimore and Annapolis terminal station, established jewelry and optical store; clean, up-to-date stock; want to retire from the jewelry business. Address O. D. Wareheim, 101 N. Liberty St., Baltimore, Md.

JEWELRY STORE for sale; a good opportunity for a practical watchmaker and jeweler to get a good business stand; new stock and fixtures; low rent and good location; write for further particulars. Address E. W. Button, receiver, Parker & Kolb Co., Bridgeport, Conn.

BUSINESS OPPORTUNITIES
Continued.

RAISE MONEY QUICK by sending your diamonds and watches to me; liberal prices paid; reference R. G. Dun & Co., or National Banks. M. Iralson, 410 Masonic Temple, Chicago, Ill.

\$25 TO \$150 PER DAY is yours; others are now earning it, you can do likewise; if you desire to increase your salary and elevate yourself let us send you a book free, giving some valuable information how to become a professional auctioneer. Write or call at the Chicago School of Auctioneering, Dept. G., 816 Ashland Block, Chicago, Ill.

HIGHEST cash prices paid for watches, diamonds and jewelry; quick and liberal returns; all business confidential; bank references. E. Noel, 552 E. 46th Place, Chicago, Ill., Telephone Blue, 995.

MONEY ADVANCED or buy outright, watches, diamonds and jewelry; moderate charges on loans; strictly confidential; reference, Auburn Trust Co., Auburn, N. Y. Robert J. Benham, Auburn, N. Y.

AN OPPORTUNITY of a lifetime; I have a store 38 years established, doing a fine business in the best jewelry city in the United States; present invoice, \$75,000; will reduce to suit purchaser; long lease, low rent, best location in city, and the leading jeweler of the State; if you mean business answer; ill health the cause of retirement. A. E. Gates, 1 Maiden Lane, New York.

DO YOU NEED MONEY? If so, send your diamonds and watches to me and get quick and liberal returns; highest cash prices paid for entire jewelry stocks; will send our representative if necessary; business confidential; National Bank references. H. Schwartz, 807 Chicago Savings Bank Building, Chicago, Ill.

DO YOU WISH TO RETIRE? Why not turn your entire store or surplus stock into cash? We pay the highest prices, also advance liberal cash amounts on stocks; communicate with us before consulting others; we act quick and strictly confidential. Brooklyn Purchasing Syndicate, 608 Broadway, Brooklyn, N. Y., Telephone. 2328 Williamsburg.

To Let.

TO LET, desk room, from May 1. Room 74, 12 to 16 John St., New York.

PART of fine light office to let. Address Room 205, 2 Maiden Lane, New York.

TO LET, 335 sq. ft. light office; divide to suit. Room 1308, 9 Maiden Lane, New York.

WATCHMAKER'S bench room, light office; elevator service; work from office will pay rent. Room 54, 7 Maiden Lane, New York.

TO LET, a desirable office, 170 Broadway, with or without partitions; liberal reduction in rent. Particulars, Room 1003, 527 Fifth Ave., New York.

LEASE; retail jeweler wanted; double store with or without six rooms and bath; busy location in built up section in Brooklyn, at trolley crossing and "L" station. "Owner," 863 Jefferson Ave., Brooklyn, N. Y.

FOR RENT, repair shop in New York City for jobbing jeweler; dynamo and complete fixtures already installed; excellent location and good opportunity for practical man. "Repair, 3956," care Jewelers' Circular-Weekly.

TO LET, desk room with a prominent manufacturing concern in the new Silversmiths' building, New York. Address "Z., 4032," care Jewelers' Circular-Weekly.

TO RENT, May 1, desk room on 12th floor front of new Silversmiths' building, to reliable manufacturer who caters to fine retail trade. Apply to the Chas. M. Robbins Co., Room 1501, Jewelers' Bldg., 9 Maiden Lane, New York.

TO LET, third floor of building in Newark, N. J., opposite Market St. station, with steam heat, power and elevator service; size of floor, 115 ft. by 39 ft.; well lighted and specially adapted for manufacturing jewelers. Address Cyrus Currier & Sons, 365 Market St., Newark, N. J.

For Sale.

HIGH CLASS show cases and all kinds of store and window fixtures for sale before May 1. Hirschberg, 151 E. 14th St., New York.

FOR SALE, one steel lined burglar and fireproof, single door, Marvin safe; weight, 5,400 lbs.; height, 63 ins. x 38 ins. wide x 31 ins. deep; original cost, \$450; will be sold at a bargain. Address W. H. Reischer Mfg. Co., Hagerstown, Md.

FOR SALE, lapidaries machinery, good as new, also 2 H.P. Diehl motor. Address "C., 4045," care Jewelers' Circular-Weekly.

Miscellaneous.

I WOULD LIKE to know the present whereabouts of one Thomas Gwaltney, a watchmaker. Address P. W. Caine, 567 Pearl St., Beaumont, Tex.

WATCH REPAIRING for the trade; best material used; work done promptly; reference given; give us a trial. P. J. Friedel, 727 Sansom St., Philadelphia, Pa.

EXPERT WATCHMAKER, all around man, looking for location to open fine repair shop; A1 reference. Henry Paulson & Co., Watch Material House, Chicago, Ill., and San Francisco, Cal.

10 TO 20 PER CENT. SAVED!

M. L. Jalonack, jewelry auctioneer and diamond expert, will pay you from 10 to 20 per cent. more for your stock of jewelry, watches and diamonds than any other buyer of stocks. Send me your surplus stock and I will send draft on First National Bank of Chicago. If my price isn't satisfactory I will return the goods on receipt of draft. Consult me about turning your stock into money quickly. All business strictly confidential. Write, call or telephone M. L. JALONACK, 5339 PRAIRIE AVE., CHICAGO, ILL. Long Distance Phone, Gray 5234.

Practical Course
in Adjusting

By THEO. GRIBI,

COMPRISING

A review of the laws governing the motion of the balance and balance spring in watches and chronometers, and application of the principles deduced therefrom in the correction of variations of rate arising from want of isochronism, change of position and variation of temperature.

ELUCIDATED AND DEMONSTRATED

by original experimental researches in the actual problem, never before published, showing the causes that are operative in the variation of rate, and leading to correct remedies. To which have been added chapters on

Published Price, \$2.50.

SPECIAL REDUCED PRICE, \$1.50,
Post prepaid.

250 pages, including 18 diagram plates; Fine Paper; Large Type; Clear Illustrations; Systematically arranged; Solid Binding.

THE JEWELERS' CIRCULAR PUB. CO.

Publishers

11 John St., cor. Broadway, New York.



It's the Little Things that count.

The dainty little things that appeal at once to the casual observer. If it's useful, as well as ornamental, so much the better. Here is a LITTLE THING, so very useful and so pretty in design and finish, that you have but to show one to make a sale, and it yields a BIG PROFIT. It is called

The Automatic Eye-Glass Holder

Can be used as well for a Pencil Holder. It is made in Enamel, Gold, Silver and Rolled Plate, in a variety of artistic designs. We fully guarantee every Holder. We mean it, and will replace any Holder that fails to satisfy. Samples sent upon request. Send for catalogue.

Est. 1832 **Ketcham & McDougall, Manufacturers**

37-39 MAIDEN LANE, NEW YORK

ALSO MAKERS OF THE LEADING LINE OF THIMBLES.





After May First

Our New York Office
will be in the

Silversmiths' Building

15-17-19 Maiden Lane - Rooms 1706 and 1707

S. K. Merrill Company

LOCKET MAKERS

FACTORY

116 Chestnut St., PROVIDENCE, R. I.

COMMERCIAL BUILDING

291-293 Seventh Avenue
Near 27th Street



New and Fireproof
10-story Store and Loft Building
Passenger and Freight Elevators
Steam Heat, Electric Power
Finished Walls, New Plumbing
Choice Location for Manufacturing
Near New Penn. R.R. Depot

C. F. BEDELL CO.
BROADWAY and 71st STREET
Telephone, 6000 Columbus

S. F. MYERS BLDG.

47-49 Maiden Lane, N. Y.

For Rent

A few choice, light and
very desirable offices

Moderate Rentals

Details of

J. A. MYERS

On Premises

Learn Watchmaking

Refined, profitable labor. Competent men always in demand. We teach it thoroughly in as many months as it formerly took years. Does away with tedious apprenticeship. Money earned while studying. Positions secured. Easy terms. Send for catalogue. Address

St. Louis Watchmaking School, St. Louis, Mo.

A.W.C.CO



14K.
C-429

Liberality and Economy Combined

Unusual liberality is shown in the quantity of gold employed in the construction of our inexpensive cases, while the decorations denote an inviting artistic generosity.

They are built to enlist the attention of the man with an economical streak and a knowledge of "what's what" in pocket horology.

Sold by us directly to you.

American Watch Case Co.

9-11-13 Maiden Lane

New York

MONOGRAMS

FROM THE JEWELERS' CIRCULAR

44 pp., each containing 48 monograms in six different styles

Flexible Cloth. Price \$1.00

THE JEWELERS' CIRCULAR PUBLISHING CO.

11 John Street, New York

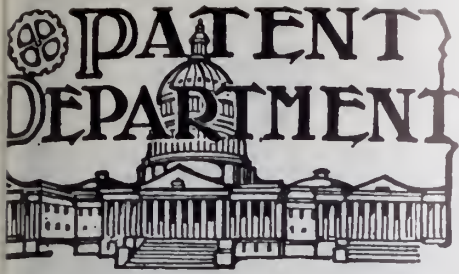

IN WHICH IS CONTAINED A LIST OF THE LATEST PATENTS GRANTED BY THE UNITED STATES AND GREAT BRITAIN, THE UNITED STATES PATENTS THAT HAVE EXPIRED AND THE REGISTERED TRADE-MARKS.

UNITED STATES PATENTS.

ISSUED APRIL 14, 1908.

884,412. FOUNTAIN-PEN. FRANK J. OBERDOERSTER and ADOLPH OBERDOERSTER, Akron, O. Filed Nov. 27, 1907. Serial No. 404,108.
In a fountain-pen, the combination of an outer casing, an ink tube slidably mounted within said casing and provided with a feeder and pen point



upon its outer end, said ink tube having a valved inner end, and said outer casing having means whereby vacuum may be formed therein when the same is drawn rearwardly upon said ink tube to draw the ink upwardly within said tube.

884,611. PIN-FASTENER. ISABELLE REDLES (now by marriage ISABELLE R. SHILL), Swarthmore, Pa. Filed May 16, 1904. Serial No. 208,230.

In a duplex pin-fastener, the combination of a pair of independent safety-pins each having a



broad flat back, and means passing through said backs for securing them together with their broadest area of contact, the back of one pin being shouldered for engagement with the back of the other pin.

884,686. TIME-STRIKE FOR WATCH AND CLOCK MOVEMENTS. CARL H. J. STRICKER and EDWARD MEYER, San Antonio, Tex. Filed April 23, 1907. Serial No. 369,802.

In a device of the character described, the combination of a snail, a slidably mounted bar, a sound

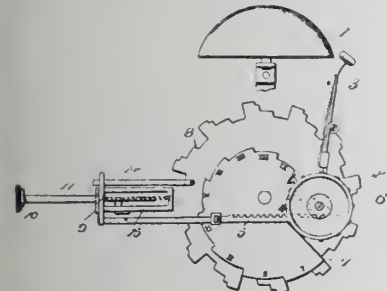

producing device operated by the slidable bar, a rod journaled upon the bar, and a tappet for engaging the snail to limit the movement of the bar, said tappet being controlled by the rod.

884,807. TIME-LOCK. JOHN FLINDALL, Chicago. Filed Nov. 30, 1906. Serial No. 345,765.

In a time-lock, the combination of a locking mechanism, a key therefor, a toothed wheel, a laterally projecting annular wall carried by the toothed wheel and normally interposed between the key and the locking mechanism, said wall being provided with a cut-away portion to enable the

key to operate therethrough, a pivoted member

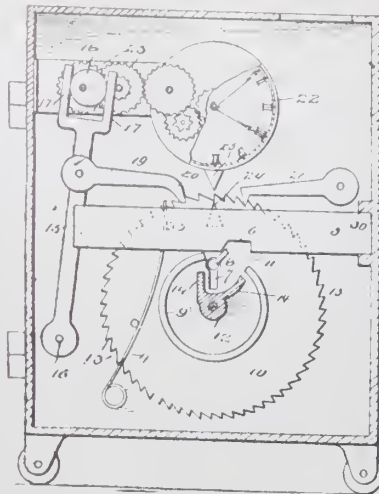

carrying a pawl engaging the toothed wheel, and means for operating said member.

884,808. TIME LOCK. JOHN FLINDALL, Chicago. Filed Dec. 29, 1906. Serial No. 350,082.

In a lock, the combination of a locking bolt, a shaft, a toothed wheel mounted upon the shaft, a pawl for operating the toothed wheel, a tumbler controlled by the toothed wheel, and a pawl carried by the locking bolt and serving the double function of preventing any backward movement of the wheel, and engaging with the tumbler to produce an operative connection between the shaft and the locking bolt.

884,809. TIME-LOCK. JOHN FLINDALL, Chicago. Filed May 31, 1907. Serial No. 376,535.

In a lock, a plurality of tumblers independently operatable, means to operate some of said tumblers manually, means to operate another of said tumblers mechanically, and means to move the me-

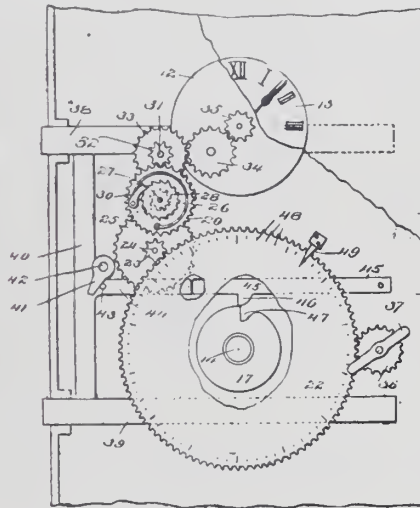

chanically operated tumbler relative to the operating means.

884,852. BALANCE-WHEEL FOR WATCHES. JOHN PORUBA, Allegheny, Pa. Filed Sept. 16, 1907. Serial No. 393,083.

A balance wheel embodying a spider frame having a centrally arranged opening and a depending hollow boss, the inner face of the boss forming a

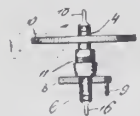

continuation of the wall of said opening, the inner face of the boss being screw-threaded and the wall of said opening being uninterrupted, a spindle having a hub portion of two different diameters thereby forming a shoulder, said shoulder constituting the seat for the lower edge of the boss, that part of the hub portion of smaller diameter

and in close proximity to the shoulder being provided with threads, the remainder of that part of the hub of smaller diameter having its periphery uninterrupted, said spindle further embodying a pair of shanks, the diameter of said shanks being the same and the diameter of each of the shanks being the same throughout, each of said shanks having a screw threaded socket, and detachable bearings engaging in said sockets.

884,961. CLOCK-MOVEMENT. GUSTAF SYLVAN, JOHANNES B. SYLVAN and EMIL W. SYLVAN, Columbia, S. C. Filed Sept. 13, 1907. Serial No. 392,727.

A movement for clocks and watches, comprising a striking mechanism, a mainspring, an escapement and a train of gears connecting the same, said train having interposed in it an intermediate coil

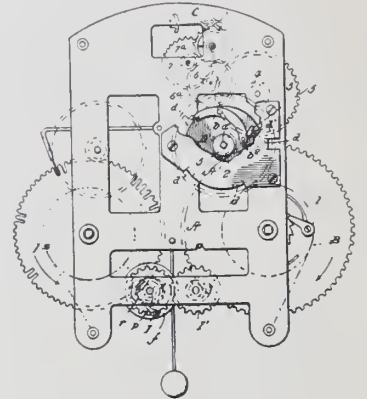

spring arranged to be automatically wound at intervals by the mainspring to actuate the escapement, a stopping mechanism for the automatic winding mechanism and a releasing mechanism connected to and controlled by the striking mechanism.

884,968. DISPLAY-HOLDER FOR GEMS. RAWSON L. WOOD, New York, assignor to J. R. Wood & Sons, New York. Filed Jan. 13, 1908. Serial No. 419,993.

A display-holder for gems comprising two half sections of a ring, a half setting upon one end of

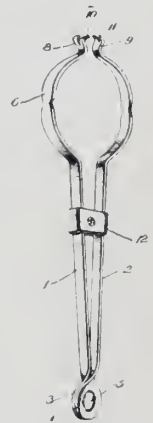

each of said ring sections, a handle upon the opposite end of each of said ring sections and means for drawing said handles together.

884,979. JEWEL-BAR. HENRY W. FISHEL, New York, assignor to himself and Theodore H. Fishel, New York, trading as Fishel, Nessler & Co., New York. Filed July 12, 1907. Serial No. 383,440.

A jewel setting provided with a jewel socket and with projections located adjacent to the socket, the projection being short and thick and of greatest



thickness at the base so that they may be upset to form beads overlapping and securing a jewel in the socket.

DESIGNS.

39,258. EMBLEM. ZOETH S. ELDRIDGE, San Fran-

STERN & CORN

71-73 Nassau Street

New York, April 22, 1908.

TO THE TRADE:



Pat. Mar. 12, 1907.
No 847,164.

The great success which the *Shuolda* pin clutch has gained in the trade has brought upon us the envy of our competitors. A suit has been brought against us for alleged infringement. We have welcomed this suit and have done everything in our power to bring it to a *hearing*.

We beg to inform the trade that we shall take care of any suits brought in consequence of selling the *Shuolda*, and will protect them against any loss or damage.

The following letter from our patent attorneys explains itself.

Respectfully,

STERN & CORN.

New York, March 31, 1908.

STERN & CORN.

GENTLEMEN:—After a careful examination of the prior art, we have to advise you that the *Shuolda* Scarfpin protectors which you manufacture are in our opinion NO infringement of any similar article made or for which letters patent have been granted.

Yours,

MUNN & CO.

SCIENTIFIC AMERICAN.



C. L. Guinand Split Chronographs with Minute Registers

The Turfman's Standard.

Remarkable for accuracy and reliability. Are cased in Gun Metal, Silver filled and Gold. Prices reasonable.

Imported exclusively by

Jules Racine & Co.,

Importers of all grades of
Watches and Movements.

103 State Street, Chicago. 37 Maiden Lane, New York.

THE GREAT AMERICAN JEWELRY CATALOG

Is a publication of real practical value; it truthfully illustrates those lines of merchandise; best adapted to the needs of the *Jewelry Trade*; its reliability is unquestionable.

SAFETY

With implicit confidence you can use it when ordering goods; it insures you against deception; remember, for every dollar's worth of merchandise you buy you are obtaining positive, intrinsic value.

Write for this catalog; it means much to you.

THE OSKAMP-NOLTING CO.

Mammoth Wholesale Jewelers
411-413-415-417 Elm St., CINCINNATI, OHIO

WANTED WATCHMAKERS everywhere to know about

URICH Perfect Fitting CASE SCREW WASHER

Will hold movements securely in their case, even when shoulder is worn away. Fits perfectly under head of screw, and is almost invisible. Prices:

Single Dozen, - - - - - 15c
4 Doz. Package, assorted, - - 50c
Gross, - - - - - \$1.50 Pat. app. for



For sale at all Jobbing and Material Houses.

S. URICH, P. O. Box 1942, New York City

PRACTICAL COURSE IN ADJUSTING.

Published Price, \$2.50.
Special Reduced Price, \$1.50, Postpaid.
All Jobbers or Jewelers' Circular Publishing Co.

cisco, Cal. Filed Oct. 25, 1907. Serial No.



399,227. Term of patent 7 years.

39,259. HEAD FOR FOBS, BROOCHES, PINS OR SIMILAR ARTICLES. HERMAN KOLLMAR, Newark, N. J., assignor to Burfistow,



Kollmar & Co., Newark, N. J. Filed Feb. 6, 1908. Serial No. 414,659. Term of patent 8 1/2 years.

UNITED STATES TRADE-MARKS.

[The following trade-marks have been adjudged entitled to registration under the Act of Feb. 20, 1905, and are published in compliance with Section 6 of said act. Said section provides:

"Any person who believes he would be damaged by the registration of a mark may oppose the same by filing notice of opposition, stating the grounds therefor, in the Patent Office, within 30 days after the publication of the mark sought to be registered, which said notice of opposition shall be verified by the person filing the same before one of the officers mentioned in Section 2 of this act. If no notice of opposition is filed within said time the commissioner shall issue a certificate of registration therefor, as hereinafter provided for."

Marks which are stated to have been "Used 10 years are registrable under the last proviso of Section 5 of said act, which is as follows:

"And provided further, that nothing therein shall prevent the registration of any mark used by the applicant or his predecessor, or by those from whom title to the mark is derived, in commerce with foreign nations or among the several States, or with Indian tribes, which was in actual and exclusive use as a trade-mark of the applicant or his predecessor from whom he derived title for 10 years next preceding the passage of this act."]

PUBLISHED APRIL 14, 1908.

Ser. No. 32,992. CLASS 37. PAPER AND STATIONERY.) JAMES W. LAUGHLIN, Detroit, Mich. Filed Feb. 25, 1908.

RED GEM

Particular description of goods.—Stylographic pens or ink-writing pencils.

BRITISH PATENTS.

(ABRIDGMENTS OF SPECIFICATIONS, 1906, FROM *The Illustrated Official Journal.*)

ISSUE OF APRIL 4, 1908.

27,638. PENS. G. E. SHAND, London. Dec. 4. A valve of any preferred construction is used to close the air-tube of a fountain or stylographic

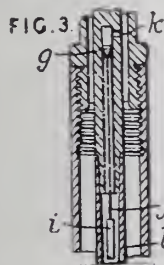

pen when the same is inverted for carrying in the pocket. In the example shown in Fig. 3, the valve *g* in the air-tube *b* is attached to a stem *j* with a weight *i*. When in position for writing, the

valve *g* is pushed from its seat past the air orifice *k*.

27,714. CLOCKS. ARTIEBOLAGET SVENSKA ELEKTRISKA URFABRIKEN, Stockholm. Dec. 5. (Date applied for under Patents Act, 1901, Dec. 6, 1905.)

Electric.—The weighted armature *a* during its descent drives the clock-work by a pawl *d*, and in its lowest position closes the circuit of an electromagnet *l* which again raises the weights or winds up a spring. The armature carries a spring con-

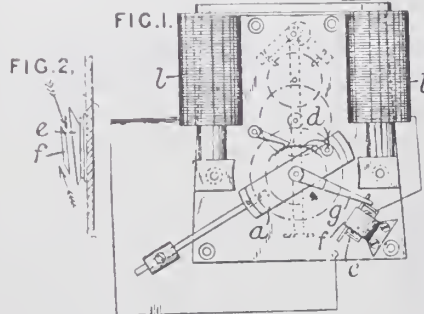

tact arm *g*, which passes up outside a fixed guide *f* as the armature descends, and then escapes and closes a circuit through a fixed contact-plate *e*, against which it is pressed by the guide as the armature is raised, and finally passes outside the base of the guide, breaking the circuit. In the form shown in Fig. 5, the circuit is closed through a tappet *t* in a spring-controlled contact-plate *s* pivoted to the armature and affixed contact-spring *p*.

27,733. HAT-PINS. W. H. JEWELL, London, S. W. Dec. 5.

In point-protectors for hat-pins, the split end of a tubular socket *b* is tightened upon the point of the pin *a* by the intumed end *c*², Fig. 1, of a screwed sleeve *c*. In a modification, the split end

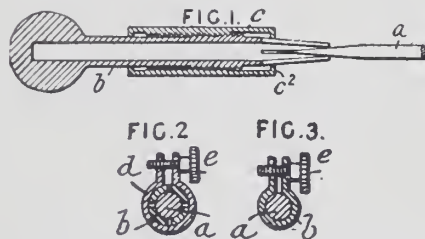

is tightened upon the point by a screw *e*, Fig. 3, with the aid, if desired, of a clip *d*, Fig. 2.

27,844. SOLDERING AND BRAZING. J. FOUILLOU, Paris, Dec. 6. (Date applied for under



Patents Act, 1901, Dec. 8, 1905.) Void. (Published under Patents, etc., Act, 1907.)

Sticks for soldering or brazing consist of a metal envelope *a* for a suitable flux *b*.

28,096. ELECTRIC JEWELRY. W. F. JENNENS and T. NEALE, both in Birmingham. Dec. 10. An anti-rheumatic finger-ring, bracelet, armet,



anklet, etc., is formed of two or more zinc and copper wires, 1, 3, plaited, twisted or knotted to-

gether, and exposed on both the outside and the inside.

(Reference has been directed under Patents Act, 1902, to Specification No. 2439, A.D. 1858.)

28,288. PENS. T. McDONALD, Middlesborough, Yorkshire. Dec. 12.

To protect the nib when the pen is not in use, the stem *a* is provided with a screw-threaded sleeve



c which, when screwed outwards, projects beyond the nib. According to the Provisional Specification, a slot and pin or equivalent connection may also be used.

UNITED STATES PATENTS THAT HAVE EXPIRED.

[Reported especially for THE JEWELERS' CIRCULAR-WEEKLY by R. W. Bishop, Patent Attorney, Washington, D. C.]

Issued April 14, 1891.

- 450,177. SPECTACLES. J. G. MISSIMER, Philadelphia, Pa., assignor to J. W. Queen & Co., same place.
 - 450,197. FOUNTAIN-PEN. L. A. SHATTUCK, Bloomsburg, Pa.
 - 450,208. COFFEE OR TEA-POT. F. D. WHEELWRIGHT, Washington, D. C., assignor of one-half to T. S. Wheelwright, Richmond, Va.
 - 450,263. WATCHMAKER'S STAKING-TOOL. GEORGE SYLVIA, Waltham, Mass.
 - 450,273. BUTTON. F. E. WILLIAMS, New York, assignor of one-half to Horton, Angell & Co., Attleboro, Mass.
 - 450,277. CANDLE-HOLDER. M. V. WONCHER, Brooklyn, N. Y., assignor to James Monds and James Ryan, New York.
 - 450,409. OPERA-GLASS. JAMES GREEN, Burwood, New South Wales.
 - 450,412. JEWELER'S STOCK. G. E. A. KNIGHT, Providence, R. I.
 - 450,432. BUCKLE. D. L. SMITH, Waterbury, Conn.
 - 450,474. JEWELER'S CLAMP. E. N. PARKER, Springfield, Mass.
 - 450,497. INKSTAND. C. W. ROHRKASTE, Beaver Falls, Pa.
 - 450,520. WATCHMAKER'S PUNCH. U. D. MINER, Starke, Fla.
 - 450,528. CLOCK CASE. H. S. PRENTISS, New York.
 - 450,529. PENDULUM-BOB. H. S. PRENTISS, Elizabeth, N. J.
 - 450,530. CLOCK CASE. H. S. PRENTISS, Elizabeth, N. J.
 - 450,538. HAT-FASTENER. W. H. THOMPSON, East Stroudsburg, Pa.
 - 450,566. WATCH CASE SPRING. J. H. FLEMING, Newark, N. J.
 - 450,579. WATCH-PENDANT. F. G. FAXON, Mt. Morris, N. Y., assignor to the Keystone Watch Case Co., Philadelphia, Pa.
 - 450,593. CLASP. J. J. UNBEHEND, Syracuse, N. Y., assignor to the J. L. Thomson Mfg. Co., Portland, Me.
- Designs issued April 16, 1901, for 7 years.*
- 34,359. SOUVENIR-MEDAL. JOSEPH LESHER, Victor, Colo.
 - 34,361. SPOON-HANDLE. JOHN CLULEE, Wallingford, Conn., assignor to the International Silver Co., Meriden, Conn.
 - 34,362. STRAP FOR EYEGLASSES. O. W. MEYROWITZ, New Rochelle, N. Y., assignor to the Meyrowitz Mfg. Co., of New Jersey.
 - 34,363. BASE FOR CLOCK CASES. E. M. JENNINGS and C. S. MOSMAN, Bridgeport, Conn., assignor to the Jennings Bros. Mfg. Co., same place.
 - 34,369. BACK FOR BUCKLES. LOUIS NEUBERGER and EDWARD CLEARY, Bridgeport, Conn., assignors to the Connecticut Web Co., same place.
- Designs issued Oct. 11, 1904, for 3 1/2 years.*
- 37,161. BADGE. V. C. BARBER and W. S. TURNER, Chicago.
 - 37,170. PLATE. W. A. PICKARD, Chicago.
 - 37,172. CLOCK CASE. G. H. RHYNDANCE, New Haven, Conn., assignor to the New Haven Clock Co., same place.

WALTHAM WATCHES



COLONIAL SERIES



These Extra Thin Watches may be had in four qualities of movements as follows:

RIVERSIDE; NICKEL;

19 fine ruby jewels; raised gold settings; double roller escapement; steel escape wheel; exposed sapphire pallets; compensating balance, adjusted to temperature and five positions; meantime screws; patent detachable balance staff; patent Breguet hairspring, hardened and tempered in form; patent micrometric regulator; tempered steel safety barrel; red gold center wheel; exposed winding wheels.

ROYAL; NICKEL;

17 jewels; red gold settings; exposed pallets; compensating balance, adjusted to temperature, and three positions; meantime screws; patent detachable balance staff; patent Breguet hairspring, hardened and tempered in form; patent micrometric regulator; tempered steel safety barrel; exposed winding wheels.

NO. 1425; NICKEL;

17 jewels; red gilded settings; exposed pallets; cut expansion balance; meantime screws; patent detachable balance staff; patent Breguet hairspring, hardened and tempered in form; patent micrometric regulator; tempered steel safety barrel; red gilded center wheel; exposed winding wheels.

NO. 1420; NICKEL;

15 jewels; settings; exposed pallets; cut expansion balance; meantime screws; patent detachable balance staff; patent Breguet hairspring, hardened and tempered in form; patent micrometric regulator; tempered steel safety barrel; exposed winding wheels.

Riverside and Royal grades are supplied in Gold and Gold Filled cases, both Regular Jointed Open Face and Calumet (Single Joint).

No. 1425 and No. 1420 grades are supplied in Gold Filled cases only, both Regular Jointed Open Face and Calumet.

Colonial Series watches have Gilded or Silver Finish Metal Dials, as may be preferred. Solid Gold, 18k. and 14k. dials at an extra charge.

Movements manufactured and guaranteed by

WALTHAM WATCH COMPANY,

WALTHAM, MASS.



Alfred W. Curzon on "The Lever Escapement"

Lecture Recently Delivered at the British Horological Institute, London, England

THE lever escapement which I am about to take as a subject to discourse upon has been so discussed, lectured and written about for upwards of half a century that at first it would appear somewhat like presumption on my part to add more; but my intention is to confine my remarks more particularly to the general construction of the lever escapement, of the pattern and proportion we find most satisfactory at the present time, and which, in my position as practical instructor to the Northampton Institute, I find is so little understood by the young men who, through lack of opportunity in a country shop, come to London to improve their knowledge. It is to those young men I particularly address my remarks, and, by diagrams and models, will endeavor to give them some sound practical points to help them in their desire to become good all-around workmen.

My first point in the outline of the lecture is to plan the escapement, so, with a series of diagrams, I will take you through the task of drawing the single-roller lever escapement of the following proportions: Wheel of 15 teeth, pallets of 10 degrees, balance arc of 30 degrees.

First draw a circle of seven inches in diameter (I say seven inches because the average wheel used for a fair-size lever escapement is seven millimeters, so that will give proportion between drawing and actual size of one inch to one millimeter.) Having drawn the circle which represents the diameter of the escape wheel, draw a perpendicular line, which will be the central line running through the pallet axis.

From this line set out 30 degrees on each side by the aid of the protractor, and draw two lines. These two lines represent the escaping angle of the wheel, and are equal to $2\frac{1}{2}$ spaces between wheel teeth.

On each side of these two lines set out in a similar manner five degrees, making an angle of 10 degrees, the width of the pallet arm. Ten degrees is as much as we could use with safety, although half the space of 24 degrees (one-fifteenth of the 360) is 12 degrees. We must have freedom for pallet and thickness for teeth, which absorb the remaining two degrees, leaving us 10 degrees for actual width of arm.

Where these lines cross the wheel's cir-

cumference, draw a line embracing the 10 degrees, and where these chord lines intersect, the center line will be the position for pallet center. From the chord line, on the left-hand side of the center, mark off two degrees on the inside of the wheel circle, for locking, and a further eight degrees for lift, making a total of 10 degrees. Repeat this on the right hand, first marking off eight degrees, then two degrees, and draw lines through these points to pallet staff hole.

If we now run two circles from pallet center, touching the two lines which mark the width of pallet down at a tangent, we have the pallet faces, if they were to be left circular.

But that would not allow the lever to detach itself from action after the impulse, so we must cut away a portion at such an angle that will cause the wheel in its forward motion to draw the pallet arm towards its center, and so detach it from action during the vibration of the balance; hence the name, the detached lever escapement. Now, from experience, it is found that 12 degrees is the least that will cause this; so from the locking corner set off this 12 degrees from the outside line, from the center of wheel on left-hand side, and draw a line. Now, this opposite pallet being unlocked and out of action, to use this same angle from the line corresponding would be to give excessive draw, so you either strike a tangent to the circle at the locking corner or fix it, from experience, at about three degrees, or take an arc equal to the other pallet from the locking corner, which, in a 10-degree pallet, is 98 degrees. Draw a line to this point, and we have the locking faces.

Now trace a line through pallet circles from locking corner to where the other circle intersects the line, marking width of pallet arms, and we have the angle of lift or impulse faces. Set out 24 degrees from locking corner of outside pallet radial line to wheel center, and we have the angle of wheel tooth. A further 12 degrees will give the thickness of tooth, allowing the point to be one degree. Circles drawn touching these lines, the circle having previously been divided into 15, lines drawn from these divisions touching these circles

will complete all the teeth. If you fill in the body of the pallets to the orthodox shape, we have the wheel and pallets complete.

Respecting the proportions for the lever and roller, in relation to the diameter of the wheel, there are none. It is more a question of the caliper of the movement; but, allowing that we can use the space available as we like, we usually adopt a chord of the wheel's circumference equal to 96 degrees—that is, from point to point of four teeth.

We will draw a line to that measurement, and lay out on each side of that line five degrees, which will be the total angle of lift from pallet motion.

From the roller center we mark 15 degrees on either side of center line, making the total balance arc of 30 degrees, and where these 15-degree lines intersect the five-degree lines will be the actual size of roller or pin circle. The width of the impulse pin is usually about five degrees, struck from pallet center.

Mark off $2\frac{1}{2}$ on either side of the five-degree line on the side going out of action, and draw the pin, which should be flatted about one-half. Draw the notch with sufficient freedom both on the side and bottom, with the guard pin sound behind it of a width of one degree. Strike the curve of the horns from the roller center, so that the impulse pin first frees them in passing out. Draw a circle just touching the guard pin, which will be the total diameter of the roller. The crescent should be a shade larger than the pin. The general form of the pin is only a matter of fancy. It should be kept quite consistent with soundness. We have now drawn a correct escapement as it should be, and it remains to copy this in making the actual thing.

We will now take a 16-size open-face movement, and proceed to produce an actual watch escapement, of the exact proportions we have just drawn.

First see there are no burrs, and that all steady pins fit well, individually, and not as they sometimes do, collectively, and also that all parts fit close down when screwed home. If it is to be free sprung you will remove the index boss, reduce the escape cock to .075 in height, and also cut away underneath the front to .035 thickness. Now put the fourth wheel and escape pinion into the depth tool and adjust the depth, and mark it off on the bar by running a small circle on the escapement side of the fourth wheel.

We will take notice of the position of escape cock and all surrounding, and decide what size escapement to use. I may here

How A Watch Business Was Tripled

The demand for the G. M. Wheeler grade Elgin, ever great, has been tripled by adding two sizes 12 and 16 thin models, thus making it a watch for the millions.

Perhaps you have also noticed that the

G. M. Wheeler Grade **ELGIN**

is being liberally advertised in all the great business-bringing publications. So you see it is just as plain as putting 2 and 2 together, that every progressive jeweler should carry this movement in all three sizes—18, 16, 12.

See jobbers' list for prices
or write the Company.

*Send for the Elgin art booklets,
"Timemakers and Timekeepers" and "The Watch."*

ELGIN NATIONAL WATCH COMPANY,

Factories, Elgin, Ill., U. S. A.
General Offices: 131 Wabash Ave., Chicago.
New York Office: 11 John St.

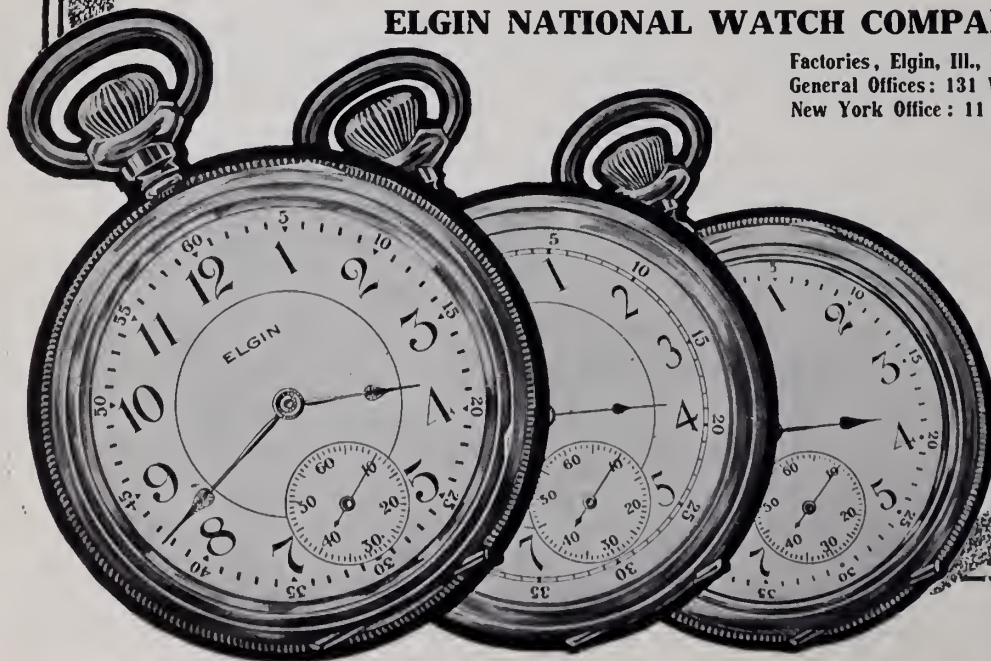

say that there is no rule or obligation to use any particular size. I think I may safely say that if the correct proportions are adhered to the size makes but little difference, except the weight of a larger escapement. Consistent with strength, a small one is preferable, and the one most used in this size movement is a large six size. The one I use has a wheel of seven millimeters diameter, and to that size all these drawings are made.

To readily find the proportions of the escapement, you can make yourself a gauge in this way: Take a piece of brass two inches square and draw an upright line. Lay the 30-degree and the five-degree lines on each side, also a line at 96 degrees to center line, which will equal four spaces of the wheel teeth. Whatever escapement you have to make, it is only necessary to ascertain the distance of centers of the wheel and pallet you can use or the diameter of the wheel. In the first case, the distance of centers being known, mark that on the upright line from the wheel's center, and draw a line at right angles to the 30-degree line, and we have the size of wheel.

Draw another line at right angles to the center line from pallet center, and at the intersection of the 96-degree line we have the distance of balance and pallet. Draw a line from wheel center at an angle of 72 degrees to center line between balance and pallet, we have the diameter of impulse circle. Take the distance between balance and escape wheel, and mark a cross score on movement, drill a small hole, and we have the position of escape wheel, and the movement is ready for the jeweler.

We can now proceed to make the pallets and wheel. Those who wish for a good, hard wheel would do well to cut it themselves. It is an easy matter for those who possess a modern lathe with its attachments. The only difficulty would be having to file out the crossing by hand, as we used to do when I first started at the trade, and when to sell a watch it must have a Lockwood wheel. To make a set of dies, as I have here, to stamp a wheel blank of three arms is a tedious, and I must say an unnecessary, piece of work. The reason why we adhere to three arms is a subject for warm argument. A four-arm die is quite an easy matter, and has long been used where a good machine wheel has to be obtained at small cost. However, we take matters as they stand, and make our wheel by hand with three arms.

Take a piece of brass one millimeter thick and gently and evenly hammer it. Cut out and turn the blank to the correct size. Make the cutters of the shape shown on the screen out of square steel to fit the wheel-cutting accessory. The first will cut the face and rim of the wheel, if the face is brought in line to the path of the cutter. Having cut the 15 faces, bring the back of the tooth in the same plane, and with the second cutter cut the backs of the 15 teeth.

Several wheels can be cut together on a sleeve and run together with shellac. The wheel is now ready for the pallets.

Now, much trouble may be saved in polishing if good steel is used in making the pallets. I myself use a length of hammered square steel size No. 14 in the Lancashire gauge, and get it flattened at the rolling

mills to No. 22, and I have never found this steel give me any trouble in getting the highest polish.

Cut this steel into short pieces of suitable length for the pallets, and drill in the center of them a small hole. They will now be ready for cutting to shape.

To make the cutters suitable, we must first obtain a perfect or master pair of pallets, and this can only be done by reducing the drawing we have just made to the actual thing with all its correctness. This is done with a tool like this. It consists, as you see, of two semi-circular protractors, with knife-edges projecting from their inner ends. One of these protractors is fixed, and is for the pallets; the other moves on a dovetail, with a Vernier, and is adjustable to the distance of centers we are about to use, and is for the wheel.

To use this tool, first fix the protractors to the distance of centers, then set the wheel index to 30 degrees and the pallet index at 60 degrees, and where these cross is the size of the escape wheel. Again, we put the wheel index at 35 degrees, and we have the locking corner of the pallets, and so on until we have a perfect pair of pallets, and from these we can shape the cutters.

I do not propose (time not permitting) to go into the subject of cutter-making. At the present day we have such excellent cutters put upon the market that it would be an easy matter to turn out some blanks to the correct angles and get them made.

The diagram now before us represents the cutter stacked on arbor ready for use. These I hold in my hand are the actual cutters I have been using for some months, and are showing slight signs of wear. You may inspect them at the close of the lecture.

We have now a plan of a table for taking the holders with steels for cutting, facing the cutters ready for action. In the next diagram I will endeavor to illustrate clearly the action of cutting the pallets in two distinct operations, each operation cutting one-half of two pairs of pallets. This same tool can be used for cutting the slots for a pair of pallets with visible stones, as used in American and Swiss watches.

The steels are now cut absolutely correct in any quantity working to the wheel without freedom. I will here show a pair of steels left from these cutters working to a wheel. Of course, it will not come out very large on the screen, but I hope it will show you with what accuracy the machine will do its work.

You will now cut the slots to receive the stones, which are cut in a tool similar to a pinion-cutting machine. The steels are held in a clamp on a dovetail, parallel to the path of cutter, which is brought down and lowered until slot is of sufficient depth.

The rough rubies are now flattened or ground against a copper lap, having rough diamond hammered into its surface. They are held in a piece of wash-leather by the finger, moistening the mill with water. Let them be fitted well, so that they are close all round. They are held on a wire in a spirit flame, and shellac is boiled in to finally fix them. They can now be held in a holder and placed on the table-rest of lathe and worked backwards and forwards against a copper lap, charged with coarse

diamond powder and oil to remove all stone protruding from the steel.

Afterwards we bring them against a zinc lap, with finer powder until we get the finish necessary, trying them frequently in the depth tool to ascertain that we are getting all actions correct, and this is the tool we use for this purpose. It is an ordinary depth tool with two plates of brass screwed to it, between which works a rack and pinion, multiplying the radius of the arc to equal about four inches.

The impulse pin is made of ruby or sapphire. The rough stone is ground in a similar manner to the pallet stone, only left thicker. It is then held in a pair of pliers and ground into a square strip, and it is ready for turning. A piece of round brass wire, about an eighth of an inch in diameter, is put into one of the split chucks, and a hole drilled up, so that it just fits the square piece of stone, which is pushed in a little way and fastened by boiling some shellac round it.

The graver is a piece of diamond fastened into a piece of brass wire. If kept moistened by the tip of the tongue, the stone can be turned cylindrical in two or three minutes, and is polished by the tool before you. It is a small cylinder of zinc charged with fine diamond powder and oil. It is kept revolving in the reverse way to the lathe-head, and can be kept moving parallel to the pin.

It is rounded off with a small strip of zinc and diamond powder. Now cut off to length, moisten the finger of the left hand and place at the back of the pin, and a touch with the diamond at the required length will instantly break it. We next shellac it up on a straight strip of brass about a quarter of an inch wide and one-eighth of an inch thick, and place it on the table-rest and flatten away one-third against a zinc lap charged with diamond powder, and the pin is finished.

We can now proceed to pivot the balance staff. Take a piece of good round steel, No. 32 in the wire gauge, and put it into your split chuck, and with the slide rest cut the first arbor for the hairspring collet, also a sharp center on end at an angle, not more than 45 degrees. Next turn a second shoulder for the balance. You can now grasp both handles of the slide-rest, and turn the slope by running the rest forward, as well as driving it along the steel. When the cutter has gone to a sufficient depth to leave an arbor the same size as front one, drive the cutter along until you have the arbor of the length you require, drive the cutter in and the staff comes off, the whole operation taking about two minutes.

Next place on a piece of charcoal and heat to a fairly bright red, and plunge into oil. Make sure with a file that it is dead hard. Place it in a split chuck, and with a No. 1 emery buff make it quite bright, taking great care not to touch it with the fingers or allow any grease to come in contact with it, or in tempering it it may show a false color. Place it in a small iron pan on a little brass filings to get even heat, and bring to a full blue with the faintest touch of purple color. This will now take the highest grade of finish. In making a staff for the escapement only two measurements are necessary before working the staff in.



F. 217



F. 218



F-3429

JAS. BOSS Stiffened Gold Watch Cases

(Guaranteed for 25 Years)



Trade-Mark in Back



Trade-Mark in Cap

- ☞ A few new models and designs in O size Hunting.
- ☞ All leading jobbers show these and hundreds of other styles in the various sizes.
- ☞ It will pay you to look over the "BOSS" lines, both in 25 year and 20 year.

THE KEYSTONE WATCH CASE CO. PHILADELPHIA.

NEW YORK

CHICAGO

BOSTON

CINCINNATI

SAN FRANCISCO



F.D. 1311



F-3329



F.D. 1310

These are the heights for balance and the total length. Take these with a slide gauge or a Boley slide gauge.

We shall find the staff measurements to be:

Height of balance from face of foot endstone.....	.162
Total length of staff.....	.280
The proportions of the staff are:	
Diameter of arbors.....	.024
Diameter of flange.....	.080
Length of pivot and cone.....	.025
Radius of pivot.....	.003

The pivot should be straight for about one-quarter to one-fifth of its total length, about equal to twice its diameter.

Now, having all these measurements, you can center up the staff and turn all parts true. First turn and polish the flange before reducing to size. After it is polished you can reduce it to the correct diameter, and back it up sharp when turning on the lathe, which is the next operation, cutting a nice clean hollow for the rivet and turning the collet arbor to size. Turn the lower roller arbor to size and the shoulder of the roller quite square. The size of this shoulder should be about $2\frac{1}{2}$ times the diameter of arbor.

All parts are polished with a polisher made from a piece of black hammered steel. Taper for about two inches, and the angle which rests against the shoulder is to be ground back 10 degrees, if you turn nice and smooth. Diamantine is the only medium you need use. Keep the polisher filed smooth and the diamantine clean. Cut off the arbor and turn the pivots to the measurements given, and you can either polish them with a soft steel polisher and red stuff burnish them with a hard steel burnisher polished upon a No. 3 emery buff, the pivot revolving upon a soft steel bed.

All this can be done in the modern lathe with most perfect accuracy and truth. If you center the two ends, you can grip one end in the split chuck and finish the other end complete with pivot; but after that I would advise you to use a wax chuck for the other end. The pivots in the case will be lapped.

Here we have the pivot-polishing attachment set for polishing. You will notice the pivot rotates parallel to the axis of lathe. The inner edge has a rounded corner, so as to fit the conical part of pivot, while the flat face of lap below polishes the straight part of pivot. A bell-metal lap, of about half an inch diameter, raised about two-thirds of its radius above the center, will polish the pivot we require. The lap should be running at a greater speed than the work, and, in addition to a slight pressure against the pivot, it should be drawn backward and forward to avoid lines. Fine red stuff should be used on lap. The pivot is rounded off on its end by a hard steel burnisher passed over the end downwards, finishing at its center, to prevent raising a burr. The staff is now complete, and can be riveted into the balance.

We will now make the roller and lever. Make a rough roller and broach it on to the staff. Fix it on an arbor, and turn it true and flat, and it is ready for marking the pinhole. In this case the total distance between balance and pallet holes is .210 and our lever and roller proportion is three to one. We divide this number by four which gives us $52\frac{1}{2}$ for roller and $51\frac{1}{2}$ for

lever. We take the total now before us, and set the Vernier at that measurement, and place the roller in this position, and with a tap of the hammer we mark the roller.

In this place drill a hole for the impulse pin, which should be about .016 diameter. We next fit a steel drift into this hole, the same shape as the flattened pin, and place it in this tool. Adjust the hole so that the punch touches the center of hole. Screw up the screw, and the hole will be crushed into the shape required. It is now replaced on the arbor, and finally turned smooth, true and flat.

Harden as we did the staff and temper the same color, and it is ready for polishing. First grind the face flat on a piece of ground glass with oilstone dust and oil. Next put on arbor and polish the back in swing tool like this, a steel polisher with a square edge being used first with oilstone dust and finished with diamantine. The edge can be rapidly polished in the lathe, revolving on an arbor with the polishing lap, as used in polishing pivots, but with a square-faced lap.

The crescent is done in this tool. It is held here as shown, and a round steel polisher is used between these sapphire guide pins. Grind with oilstone dust until of right depth, then clean off and polish it. Now it only remains to polish off the two corners and face, to shellac in pin, and place on balance staff to be finished.

To make the lever, take a piece of steel .100 wide and .018, file the wings, and cut the notch at one end and open out to fit the roller pin. Leave the notch a little longer than square. We can shorten it when adjusting it into the frame. Drill the guard pin close in behind, set the slide gauge to the length just given for the lever, place the notch under the pin where we first had the roller, press down the top spring that carries the marker, and scratch the position of pallet staff hole and drill it. You can file up the general shape of the lever to please yourself, and it is ready for use.

We will now take the pinion. First polish out the leaves with a slip of boxwood and diamantine. Run it up in the turns or lathe, and see that it is true. Turn one of the arbors true and taper, fit, turn, and drive a brass collet home to the leaves. Now shorten away the leaves until they are a little shorter than the space between the plate and face of the escape cock, shorten the arbor, and turn the top pivot. Keep it as short as possible, and cut a nice deep, clean hollow into the pinion head, but not to come out into the leaves. The hollow here is necessary to prevent the oil getting into the pinion. Burnish the pivot in the same manner as the staff, face the pinion, take the total length, and finish pivot. As with staff, turn on wheel, and it is finished.

Broach out the pallets and lever quite flat, and fit a small polished arbor into them. Cut off a little longer than the pinion and turn rough pivots, as the holes, not being jeweled, we must leave the final fit until we have the escapement planted and jeweled. Put the staff into lever and pallets, fix in guard pin, and we have the escapement ready for planting.

To plant the escape, put the wheel and

pallets into the depth tool, and adjust the depth until the shakes and locking are equal, and score this on the inside of the bar. From the wheel-hole put the roller and lever into the tool and adjust depth and make a cross score on bar. Drill a small hole, and put in mandril and upright to escape cock. Also turn a sink in plate large enough to free the wheel teeth, and about half as deep again as the wheel. Now we must sink for pallets.

This is the slotting machine to cut the freedom for pallets or lever and to sink the escape cock in a repeater.

Having cut away for freedom, we can put the escapement into the frame, and if we have worked true to all the various measurements we shall find the wheel and pallets act as they did in the depth tool, and as a tooth drops on to the opposite locking the roller pin will leave the notch and the guard pin take a safe position. We can now, with a fine pointer, make two scratches on the plate beside the lever and drill a hole on each of these lines for the banking pins. Drill two holes through the pallets and lever to pin them together, and the lever can be hardened and tempered and the pallet holes jeweled.

Polishing the escapement is a subject which would be better explained by showing you the tools used for holding the lever and pallets. The materials necessary for polishing are few after grinding smooth—diamantine mixed well with olive oil into a very stiff paste. I may say here that five minutes spent on mixing is not too long, adding more diamantine as the paste gets too soft; red stuff is good for pivots, and sharp red stuff, well mixed and allowed to stand for some weeks before using, is the best for brass.

Black hammered steel is best for steel polishers, zinc for a large flat steel surface, also bell metal and tin for brass.

Now it is polished up, pin it together, pivot and fix the pallet staff, rub on the wheel, and put together in frame, and for a final test we can put it into the angle meter here shown and see that the action shows what we intended—that is, 30 degrees balance arc; pallets, two degrees, locking, eight degrees lift; wheel, two degrees; drop, one degree shake.

I trust I have in this condensed description given you a fair idea how to go about making an escapement, and will now do my best to give illustrations of a few common faults, errors and their corrections; also a few complicated movements where special care is necessary in making the escapement.

The sale of the W. A. Sturgeon & Co.'s stock in Denver, Colo., has attracted a great deal of interest, principally because of the size of the stock, which inventoried at \$387,000 before the auctioneer began. Crowds have been in attendance right along and prices were better than expected, one piece going for \$2,800, while a number of others brought from \$600 up. An experiment was the "Mechanics' Night," when filled watches were sold. A "Diamond Night" and "Cut Glass Night" were also advertised. The sales conducted at the stores of John Hellerich and Petz & Thiry have also drawn well. Sturgeon & Co.'s sale was conducted by Jas. L. Hand.

Brooch and Case Combined

Which Enables a Watch to Keep Correct Time

Cannot Be Lost
Will Not Pull or Wear Off

Dubois

Safety Chatelaine Brooch Watch Case

Patents Pending in U. S. and Foreign Countries.

MERITS — Holds the watch firmly and securely, thus preventing the movement from being jarred, as there is neither swinging nor bobbing up and down while the wearer is walking or running. Protects both the case and garment from wear.

UTILITY — It can be raised so as to read the time, and reversed to have either the dial or back facing front, without removing brooch pin or watch from the garment. Can be worn on the shoulder, belt, chain or fob.

ARTISTIC AND PRACTICAL — The only brooch and watch combined. Affords absolute security, as it has a safety catch. Nothing to wear out, as it works on friction bearings. Eliminates the possibility of loss of the watch owing to either bow, hook, swivel or link wearing out, breaking or coming apart, as in the old style chatelaine. Does not interfere with either winding or setting of movement.

Licensed under Wachter Patent Ball-Bearing Bow

DUBOIS WATCH CASE CO.

21 and 23 Maiden Lane

NEW YORK CITY



Side View of Watch.



Raised View.

Made for All Sizes of
Ladies' Watches



Desk Watch.



Front of Watch.



Back of Watch.

Watch Repairing.

By H. REINECKE.

(Continued from issue of Mar. 25.)

THE subject of watch repairing may be divided under two heads, one of these heads embodying repairs from breakage and other accidental damage, and the other embodying such repairs as cleaning, ordinary wear and deficiencies in original construction.

For the former the American lathe is the all-important tool. The American lathe is the tool par excellence for the machine-made lever watch and for various timepieces of American manufacture. The almost universal adoption of the lever escapement for pocket watches has reduced the watch to a machine, to be manufactured and repaired on mechanical principles. A watch repairer of the machine-made lever watch need not be a tinker and ought to be a skilful mechanic of manual dexterity and theoretical education. He knows what is required of a railroad timekeeper, and is ready to drop scientific quibbles. For him the American lathe with its split chucks and all attachments are his all in all. But all these attachments to be useful to the greatest extent must be studied by our text-books and any literature within reach.

The jaws of a wire chuck are the base of a triangle, and the apex of that triangle is that point on the outside of the chuck riding on the incline of the lathe spindle. The lines of force exerted in this clamping action are represented. If we have properly fitting and true chucks we can still affect their truth and accuracy of holding work on just such lines in several ways. If we force too large a piece into the chuck we will spring the jaws outward and practically enlarge the outer diameter of the chuck so that the seat will no longer fit the chuck, and we have the same results as if the chuck seat were originally made too small. If we use the chuck on too small a piece of work, then the jaws of the chuck will close further than they were intended to do. Hence we see that in order to obtain the proper direction of one of the lines of the force of compression which holds the work properly we must keep our chuck nearly the proper size, so that the line of force may pass midway between the length of the jaws. When this is the case the bearing is such that all the forces are balanced within the triangle of the jaws and there is no strain on the springs which hold the jaws in position and form part of the body of the chuck. Moreover, if the piece of work be much too large or much too small, the jaws will not be parallel when they are closed upon it, and we then have the work held by one end only of each jaw.

This would not be so bad if that jaw were rigid, but it is not. It is held in place by a spring. And we then have a bearing along either of the lines connected with the base line of the triangle completed by the springs which hold the jaws. Of course, any considerable pressure will then cause wobbling of the work, and this will be greater as the spring is weaker and less as the spring is more powerful.

This brings up the practical question as to how far a chuck will spring and do reasonably good work. Chucks are generally

sized with a unit of measurement of one-tenth of a millimeter, or its equivalent in one-thousandth of an inch. Thus No. 4 chuck means that the jaws are parallel when there is four millimeters; No. 4½ equals 0.45 millimeters, etc.

A reference to the scale of sizes given by the manufacturers will show half sizes from No. 3 to No. 10; thence forward they increase by tenths of millimeters to No. 70, which is seven millimeters in diameter. Thus if a workman has a piece of work between No. 5 and No. 5½ he will not have to spring his chuck jaws more than one-fourth of a size to fit it. The use of half sizes is strongly recommended for the further reason that many staffs and arbors are made to half sizes, or nearly so, and in such cases the work will be found to fit the chuck perfectly, with, of course, a great gain of the truth and accuracy of the work to be performed upon it. Above the No. 10 size the amount of work is much less, and consequently the need of half sizes is not so great, although in any case they would be an advantage.

The workman may and should habitually turn his work to a size that will fit his chucks, or nearly so; and the resulting gain in accuracy is an important one. Below No. 10, however, it is best to provide yourself with half sizes of chucks and not attempt to disturb the carefully thought out proportion of a fine watch.

(To be continued.)

Selling the Correct Time.

CORRECT time is "sold" to many watch and clock makers in London, Eng., by a woman, a Miss Belleville, who is reported to make a comfortable living by her strange vocation. The father of the present "time vender" in 1835 was assistant to the astronomer royal. He hit upon the bright idea of taking around to the principal London watchmakers a correct chronometer. In this way he soon built up an income of about \$2,500 a year. When he died, in 1856, his widow was granted the privilege of having her chronometer corrected at Greenwich whenever she liked and "peddled" the time until 1892, when she reached the advanced age of 82 and retired. This right to a monopoly of the absolutely correct time did not leave the Belleville family with the retirement of the old woman, however, for her daughter succeeded to the lucrative job. Every Monday morning she goes from her home in Maidenhead, on the Thames, to the royal observatory at Greenwich, where she receives from the keeper an official document saying that her chronometer differs from mean time by so many seconds and tenths of seconds. Such a favor is granted to no other person, and armed with this exclusive credential Miss Belleville sallies forth to correct the timepieces of the world.

She has about 40 customers in London, scattered all over the city. To each she repairs in turn and permits them to correct their time in accordance with that of her own chronometer and the official document. From these 40 customers of this woman the rest of London gets its ideas of time.

Simon Stahl has moved from Gorham to Berlin, N. H.

Micrometer Gauge for Heights.

WHEN we desire to ascertain the height of a spring suited for a given barrel, it is necessary, says the *Bulletin Mensuel*, to measure with the tool called the "douziemes" (12ths), or "dixiemes" (10ths), the total height up to the seat of the cover or groove and then deduct therefrom the thickness of the bottom.

This operation is very liable to result in an error, especially as it is not always easy to adjust the point of the tool to the groove.

The micrometer, illustrated herewith, enables us to obtain absolutely, without deduction, the height of the spring to be

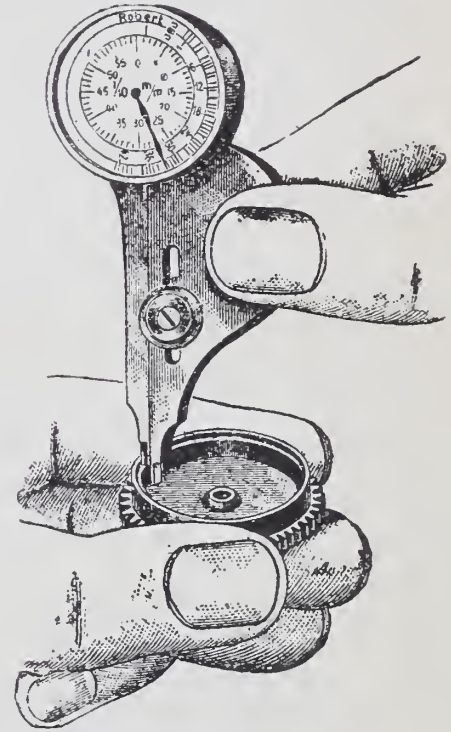

DEVICE FOR MEASURING SPRING'S HEIGHT.

used. One of its jaws is allowed to rest on the bottom of the drum of the barrel, while the other is brought to a stop at the groove, the difference between them being shown on the index.

This index is divided into millimeters and tenths, as well as another special scale for springs known as the Robert measure.

It is possible to measure up to six millimeters with this tool, in such a manner that it is adapted not only for measuring barrels, but for other purposes. It enables us to ascertain immediately the depth of a plate-sink, the kerf in the head of a screw, etc.

One of the first clocks made in Vermont is now owned by F. H. Brown, with Phillips & Lucas, jewelers, of Montpelier, Vt. The case is of Vermont bird's-eye maple and mahogany, and is about 38 inches high. The old timepiece was made by A. Barnes, of Jamaica, about the year 1825. Mr. Barnes was a manufacturer and repairer of clocks at that place, and is said to be one of the first to ply the trade in the State of Vermont, having come from Connecticut.

REPEATED TRIUMPH OF THE
PATEK, PHILIPPE & CO.
WATCHES

RECORD of 1907-1908

Key Observatory Trial of Watches and Chronometers

The First, Second, Sixth, Seventh, Eighth and Ninth
BEST RECORDS

Geneva Astronomical Observatory Timing Contest
53 out of 101 Prizes, namely:

The only First Prize for Best Average Running among Makers

4 First Prizes out of 5

Including all the highest and the nearest to perfection ever obtained by a portable timepiece

10 Second Prizes out of 18

9 Third " " 17

12 Fourth " " 26

7 Honorable Mentions " 18

10 Single Prizes " 17

19 Manufacturers Participated

Awarded Hors Concours (Beyond Competition): Milan, 1906; St. Louis, 1904; Chicago, 1893; Paris, 1900; Paris, 1889; Antwerp, 1885; Zurich, 1883. Centennial Exposition: Philadelphia, 1876. Gold Medal: Nuremburg, 1905; London, 1885; Calcutta, 1883; Croningen, 1880; Paris, 1878; Vienna, 1873; Paris, 1867; Paris, 1855; London, 1851; Paris, 1844. Diploma of Honor: Nice, 1883.

68 Nassau Street, NEW YORK

GENEVA, SWITZERLAND

New England Watches

☞ The best medium priced Watches made.

☞ High-grade, accurate time-pieces, guaranteed in every particular.

☞ Write for information, to

The New England Watch Co.

Waterbury, Conn.

Chicago

San Francisco

A Page from Watch History

The picture at the left shows the old Roman tower in which the **Vacheron & Constantin** watch factory was located in the early days of watch history.



The picture at the right shows the present factory, built in 1875, and remodeled some years ago.



These illustrations not only mark the progress of the **V. & C.** watch, but of the entire watch-making industry, for the **Vacheron & Constantin** was recognized as the standard of excellence when the watch was first placed on the market in 1785, and is so recognized to-day.

It has always led in correct, scientific principles, in absolute accuracy, and in all the various improvements in watch manufacture since the establishment of the house. It has captured many first prizes in international timing contests, and its unquestionable superiority renders it the most salable and profitable high grade watch that the dealer can offer his customers.

The **V. & C.** line embraces every variety of adjusted watches, complicated watches, extra flat, ultra flat, and enameled, carved and jeweled watches.

EDMOND E. ROBERT, Sole Agent, 3 Maiden Lane, New York

The Favorite Movement with both Trade and Public

The Omega Movement

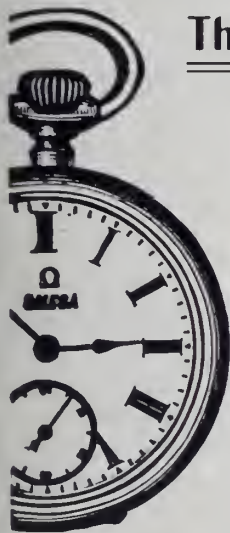

stands in high favor with the trade, and is constantly increasing in popularity for the reason that the public is quick to appreciate its merits.

The man who carries an Omega is proud of it and misses no opportunity to sound its praises to his friends. He finds it invariably and uniformly reliable. He learns to depend upon it and it never abuses his confidence.



Ω
OMEGA

Adaptable, Interchangeable, and Suited to all Requirements

The Omega is made in all sizes to fit regular American cases, besides a number of Swiss sizes. Every part is interchangeable, and all are made with lever escapements, double roller and pendant set. There are six different grades — from seven jewels to twenty-one jewels — adjusted to heat, cold, and five positions.

EDMOND E. ROBERT
3 Maiden Lane New York

WESTERN SELLING AGENCY
Omega Watches
Heyworth Building, Chicago

CROSS & BEGUELIN
31 Maiden Lane New York

THE ROTATOR



FRONT VIEW

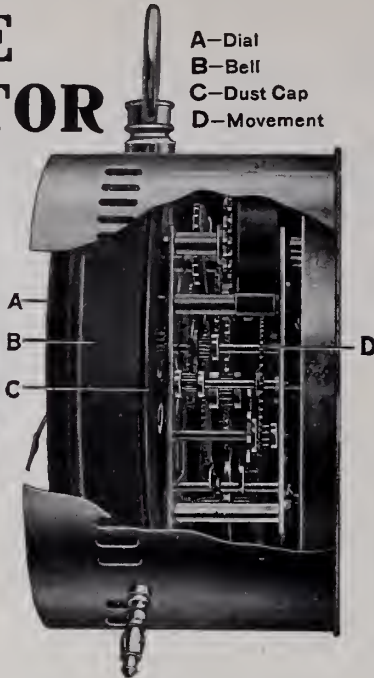

INTERIOR VIEW

☞ Highest Grade, Lowest Price, Alternating Alarm. Rings at intervals of fifteen seconds with manual stop. Largest and loudest bell of any nickel alarm clock made. Bell contained entirely within the case. Movement fully protected from dust by "Dust Cap" shown in cut.

☞ Sold by all leading jobbers. If your local jobber does not handle the ROTATOR, write us.

THE E. INGRAHAM CO.
BRISTOL, CONN.

— CARD —

OUR FACTORY and WAREHOUSE
WERE NOT IN THE LEAST INJURED

By the conflagration which on April 12, 1908, destroyed so large a part of the City of Chelsea, a suburb of Boston, Mass.

CHELSEA CLOCK CO.

16 STATE STREET
BOSTON, MASS., U. S. A.

Makers of
8-DAY
HIGH-GRADE
CLOCKS

SHIP'S BELL, MARINE, OFFICE, MANTEL and **AUTO CLOCKS**, Etc.

AUDEMARS, PIGUET & CO.,

BRASSUS and GENEVA.

Manufacturers of Superior

Plain and Complicated Watches.

Represented by

A. WITTNAUER CO.,

9-11-13 Maiden Lane,

NEW YORK.

GUN METAL



WATCHES

Positively the most interesting line of moderate priced Gun Metal, Nickel, Gilt, Enameled, Silver and Gold Watches. GUARANTEED THIN - MODEL WATCHES.

Does Your Stock Move?

Drop us a line. We will present to you a new proposition to increase your sales. We furnish you the whole outfit free of charge, delivered at your store.

American-Swiss Watch Co.
1 MAIDEN LANE, NEW YORK

HALL CLOCKS



Elliott's
Celebrated
Tubular
Chimes

**HARRIS &
HARRINGTON,**

12 BARCLAY ST.,
NEW YORK

Sole Agents to the Trade
for
J. J. ELLIOTT & CO.
LONDON.

THE Ægis Case

(PATENTED)



THE ÆGIS is a new creation in gold case making. The center and bezel are in one. Instead of having the ordinary Cap, this case is provided with a rigid metal movement Cup, held friction tight in position. This Cup gives protection to the movement such as cannot be secured with the conventional jointed cap, while dust is thoroughly excluded from the front by means of the one-piece center and bezel.

MADE ONLY BY

ROY WATCH CASE CO.

21-23 MAIDEN LANE
NEW YORK

San Francisco Office, 704 Market Street

HOROLOGICAL DEPARTMENT

BRADLEY POLYTECHNIC INSTITUTE
Formerly Parsons Horological Institute
PEORIA, ILLINOIS
LARGEST AND BEST WATCH SCHOOL IN AMERICA
We teach Watch Work, Jewelry, Engraving,
Clock Work, Optics. Tuition reasonable. Board
and rooms near school at moderate rates.
Send for Catalog of Information

WATCH REPAIRING FOR THE TRADE

Careful, Reliable, Prompt Work. Trade Refer-
ences. Price List on Request.

A. D. PAPAZIEN

71-73 Nassau St., Cockroft Bldg. NEW YORK

Ball Watches

THE RAILROAD STANDARD

The Watch Inspector's Friend

WRITE TO-DAY FOR OUR DEALER'S PROPOSITION

Minneapolis, March 12, 1908.

Gentlemen:
Your 18 size "Official" No. 548110 arrived just
in time to aid me with my watch inspection work, as
my electric clock was out of commission for 23
days, during which time your watch varied only
4 seconds. Very respectfully,

L. L. WILLIAMSON.

Railway Watch Inspector
1717 E. Franklin Ave.

The Webb C. Ball Watch Co.

Ball Building
Cleveland

Railway Exchange
Chicago

Pacific Type Fast Express Engine for
New York - Boston Service.

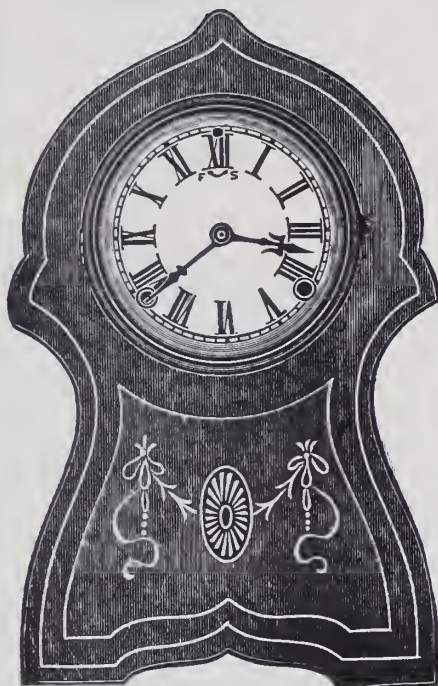
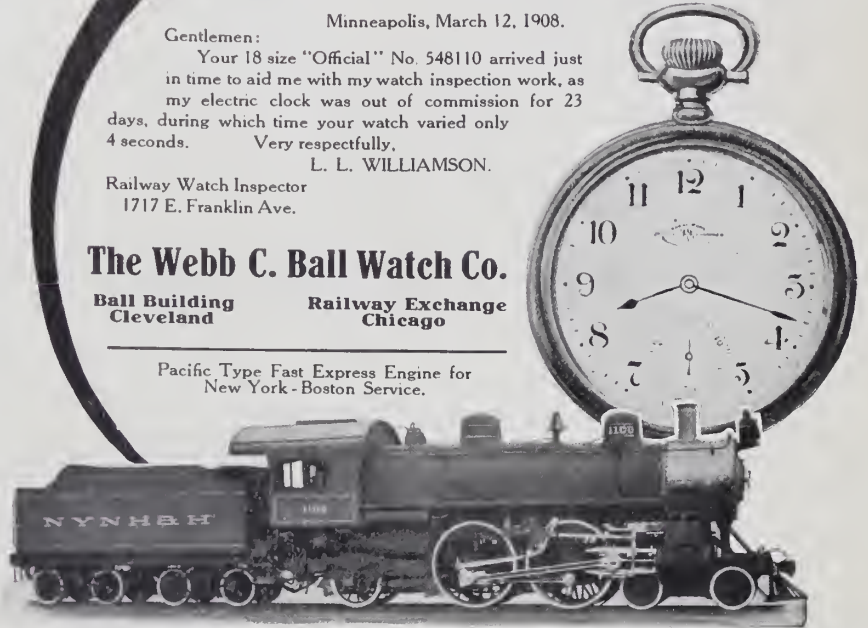

MANCHESTER

Height 13¾ in. Width 8¾ in.

SESSIONS CLOCKS

Superior Finish
Popular Prices

We have added a number
of fine marqueterie cabinet
clocks to our line which will
interest you.

*The Sessions Clock
Company*

FORESTVILLE, CONN., U. S. A.

New York Salesroom, 37 Maiden Lane

JULES JÜRGENSEN

Watches and Chronometers

PARIS—"THE GRAND PRIX"—1900

SOLE

RUDOLPH & SNEDEKER
65 Nassau St., New York

AGENTS



STORE KEEPING DEPARTMENT

Jane Wedding Advertising.

An article of genuine value and practical help to the retail jeweler is now being prepared expressly for THE CIRCULAR-WEEKLY. The date of publication will be announced later.

The Best Arrangement of the Storeroom in Order to Get the Maximum Amount of Daylight.

From the *Illuminating Engineer.*

(Continued from issue of April 15.)

IN a great many of the older buildings the windows are set back from the face of the building to give the wall an appearance of strength. This distance by which the window is set back, or rather, the distance by which the window-cap projects over the window, is called the reveal. So long as the window is of plain glass it is a matter of indifference whether the glass be flush with the face of the wall or set back several inches, but with window prisms it is quite a different matter. If they are set behind a heavy reveal the ledge casts a deep

shadow over them. Summer to protect the show window and its admirers from the sunshine, should run from the transom bar below the prism plate and not from the extreme window top, as is frequently seen. In this case the transom bar will appear a little heavier than that shown in the sketches, and the awning may be made more nearly horizontal than

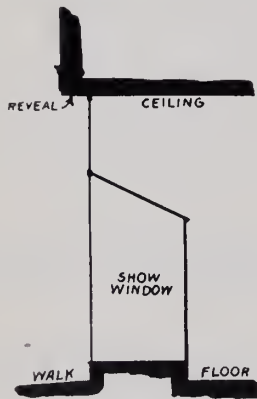

FIG. 5.

shadow over them. They cannot transmit light which they do not receive; the sheets of window prisms should always be placed flush with the face of the wall. If the window cannot be moved out conveniently, the prisms may be set in a separate vertical frame outside the plain glass window.

The door forming the entrance into the store may well be placed flush with the show window. In this case it will naturally extend to the transom bar above which the prisms will be located. In most stores the owner desires to have the door set back even with the rear of the show window. In this case the prisms should continue over the doorway in the same plane as those over the show window. Of course, it will not do to bring them in and put them over the door in its usual position.

The canvas awning, which is used in

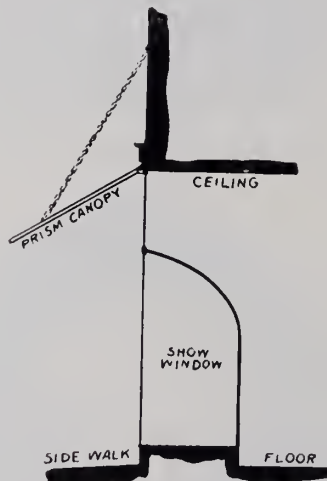

FIG. 6.

usual by giving the support rods a sliding hinge instead of a fixed one.

When the sun shines on the prisms it is generally not necessary to diminish the light thrown into the room. On bright days in Summer, however, and particularly with a south or west exposure, this sunshine through the prisms is likely to be uncomfortably strong, and for such occasions white Holland shades should be provided, which pull down just inside the prism sheets. They are, of course, easily and quickly adjusted from the interior to suit the convenience of the salespeople. This white glazed material is a most excellent one to serve as a sunshade on any window independent of the presence of prisms. In the sunshine such a shade gives off a strong, well-diffused white light highly agreeable to the eyes. This light resembles skylight very closely.

The prisms accomplish their purpose by directly throwing the skylight back into the

store. If one stands back by the counter and looks at the prisms he sees the sky through the prisms. If the prisms throw a good light in his direction they must necessarily look bright to him. This is the simplest manner of testing whether the prisms contribute properly to the illumination of any locality. Place the eye there and see if the prisms look bright. This very feature of their use sometimes makes the prisms rather annoying in a salesroom which is unwisely decorated.

As the customer walks into the store and down the aisle the bright light from the prisms is on his back and in the face of the salesman who comes to meet him. The face of the prospective buyer is lighted by the diffused light from walls and ceiling, and if these surfaces are not pretty light his face is hard to recognize, so long as he keeps his back to the window. The moral

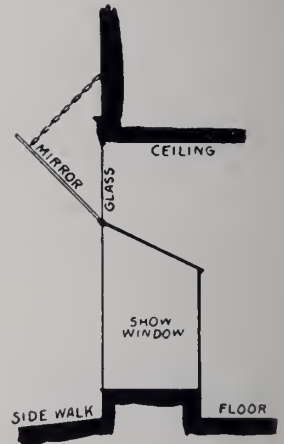

FIG. 7.

of this is to make the decorations as light as possible. In any event the salesman may be sure that this inconvenience is little detriment to trade, for under the circumstances described the customer is perfectly at his ease and the whole interior looks bright and cheerful to him.

With increased height of the buildings opposite a window less skylight falls upon the prism plate, and the prisms appropriate to such surroundings appear less and less bright from the interior. When the opposite buildings become much taller than the width of the street, it generally becomes advisable to set the prism plates in a frame inclined to the vertical, a position in which a much stronger light falls upon the prisms. This construction is illustrated in Fig. 6, which represents a vertical section similar to the other figures shown. The

Storekeeping Department.

prism sheet in this position has been called a canopy and serves to protect the window and the passer-by from wind and rain. Even on a fair day many a shopper will stop and look at such a window simply because of the impression of shelter and protection afforded by the canopy.

The upper surface of such a canopy is smooth and should be cleaned frequently.

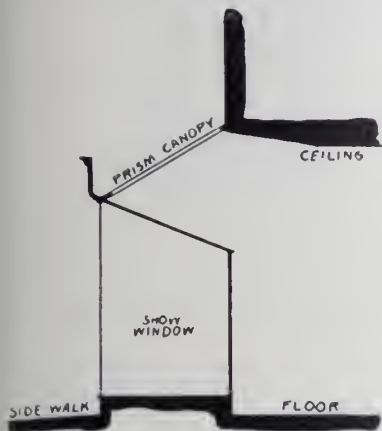

FIG. 8.

A cleaning once a week will give excellent satisfaction in most localities, while it is safe to say that in most places these canopies are cleaned much less frequently—a few times a year, perhaps. The prisms themselves are of clear glass, but they are deeper and sharper than window prisms. The faces are arranged so that they act by reflection instead of refraction, but they are not silvered. It is the sort of reflection which one finds when he tries to look diag-

of the canopy, however; but they receive from the sky a much smaller amount of light than the canopy does. On the other hand, they present a rather disagreeable appearance from the interior, and their sloping position on the window, as seen from the street, does not agree well with ordinary architectural lines. As generally used they are much smaller than they could be to good advantage; the top of the mirror may run well above the top of the window. Their mounting should admit of lowering for frequent cleaning.

In remodeling an old store it is quite common for the front on the ground floor to be set out several feet beyond the face of the building. This alteration furnishes opportunities for obtaining an excellently lighted salesroom by working in a canopy prism plate over the show window as shown in Fig. 8. Fig. 10 shows a similar suggestion in which the mirror is used in place of the prism canopy. This detail gives opportunity for a high show window. The purpose of the clear glass above the mirror is simply to keep out the weather. If this glass were removed and placed in a vertical position behind the

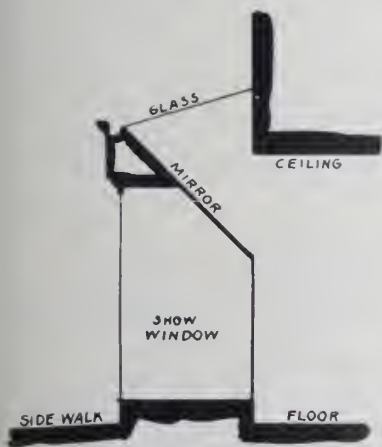

FIG. 10.

onally through the bottom of a glass full of water. One finds that for certain angles he cannot see through the bottom; it becomes a perfect reflector. The canopy gives a good light under almost all circumstances.

In England the old-fashioned mirror reflector shown in Fig. 7 has been used a great deal, and to some extent, also, on the Continent of Europe. It is made of a thin glass, having shallow flutes about an inch wide. The lower side is silvered. The glass is mounted in a wooden frame and has a wooden back or lower side. These mirrors give a good light—hardly as good as that

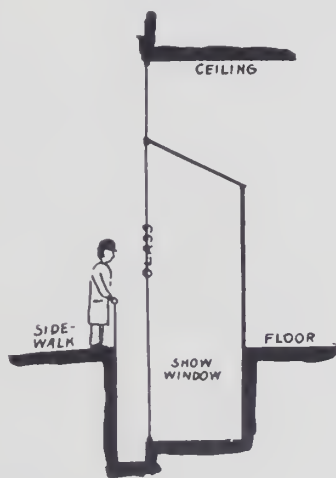

FIG. 11.

show window, it would improve the appearance from the interior, but would involve difficulties in a snowstorm.

On the Continent of Europe the property owners are not allowed to excavate and make use of the space below the sidewalk and beyond the lot line.

The show window is sometimes arranged as shown in Fig. 11. The window is carried down several feet below the level of the sidewalk with a narrow area in front. A delicate railing prevents the public from coming too close. The lower part of this show window has at least one advantage over the upper part. In bright sunshine one finds it almost impossible to see clearly the objects in the ordinary show window. The reason is that the street surface under the direct sunshine is so bright that its reflection from the face of the glass is stronger than the direct rays from the feebly lighted display in the window.

About the only way to obviate this difficulty is to raise the awning and let the sun shine in the window, but this will drive the public to the other side of the street. Now, in looking at goods in the lower part of the window shown, one gets from the face

of the glass the reflection, not of the street surface, but of the vertical area wall or curbing just below the observer. By making this surface fairly dark its reflection is not seen and the objects in the lower show window come out distinctly.

[THE END.]

How an Alabama Firm Got Up a Mailing List.

AN Alabama firm thoroughly systematized its advertising. At the start a territory for a radius of about 10 miles from the store was mapped out, and they hired a man to go to every house in it and fill out a card like this:

Name
 Sex P. O.
 Mail How Often?
 Age Married
 White or Colored?
 Occupation
 Employer
 Dist. to Jonesville.
 Usually Trade at.

This card was made out for every member of the household to whom advertising matter might be sent. These names were divided into four classes, the heads of families, their wives, young men and young women. Some advertising matter is sent out each week to one of the four classes. In this way the whole list is covered every month, and every home in the territory is getting something about the store each week.

As the town has no newspaper, the mimeograph used at first has been supplanted by a small printing press that will print a sheet 8¼x10½ inches. The mailing list carefully secured and the persistent following up of each name have brought the store a gratifying increase of business. Few large stores have as systematic a method of reaching their customers.—*General Merchants' Review*.

The Way of the Enterprising.

IN celebration of his 13 years in the same location at 6 Colony St., Meriden, Conn., P. T. Ives recently conducted a special sale of watches. Mr. Ives has been engaged in the jewelry business for about 18 years.

An exceptionally attractive Easter display was that of L. A. Piaget & Co., 238 Main St., Paterson, N. J. The two windows were draped in purple and white, one containing an assortment of cut glass, while gold and diamond jewelry were exhibited in the other. In this latter window was a purple centerpiece upon which was worked out a cross of diamond brooches.

* * *

An attractive display was seen in the show windows in the store of Albert Edholm, Omaha, Nebr., Easter week. Both windows had an artistic decoration of fine ferns and greens, which fell gracefully on both sides, on the back and ceiling of the windows. In one window was shown a white ground gold articles, diamonds, emeralds, sapphires and rubies, in different shapes and combinations, while in the other was a turquoise and diamond display, blue velvet cases and light blue velvet ground being used.



Above Cut Shows Our

METAL SPINNING LATHE

We manufacture these lathes in sizes from 12-inch to 44-inch Swing, and can equip sizes 18-inch and larger with our Chucks for oval work.

Write for Catalogue **P. PRYIBIL, 512-524 W. 41st St., New York.**



A Small Compound Sand Blast

Price, \$20.00 Foot Bellows, \$6.00

WORKS AS EFFECTIVELY WITH FOOT BELLOWS AS WITH POWER BLOWER : : : :

MADE of Galvanized Sheet Iron, 10 inches diameter, Glass Top, Fittings of Brass and Iron, practically indestructible. Satisfaction guaranteed. Ask your Jobber for it, or write to us. Other Specialties: Zeuner's Best Jewelers' Saws; American Swiss Files, equal to the best imported; Gas Furnaces, for Melting, Annealing, etc., etc.; Positive Pressure Blowers.

E. P. REICHELHM & CO.
JEWELERS' TOOLS, FILES AND SUPPLIES
24 JOHN STREET, NEW YORK

1 2 3 4 5 6 7 8 9 0 1 9 0 8 A B C D E F G H I J K

Alphabet and Figures

FOR CLASS RINGS, EMBLEMS, ETC..

HERPERS BROTHERS,

SETTING MANUFACTURERS,
Newark, N. J.,

1 9 0 8

1 9 0 8 A B C D E F G H E T C. 1 9 0 8

Importer and Manufacturer of
WATCH MATERIALS, TOOLS, JEWELERS'
SUPPLIES AND OPTICAL GOODS



Bargains
in
Engraving
Blocks

Prices on Application.

Fine Gold, Silver and Platinum always on hand.
Highest Prices paid for Old Gold and Silver.

A. ZAREMBOWITZ
250 East Houston Street NEW YORK



HERMAN KOHLBUSCH, Sr.,
ESTABLISHED 1859.
Manufacturer of Fine Balances and Weights
for every purpose where accuracy is required.
Office and Salesroom, 194 BROADWAY, NEW YORK.
Send for Price List. Tel. 370 Cortlandt.



GEO. M. BAKER TELEPHONE UNION 1493-R

Gold and Silver Refiner and Sweep Smelter

Office, 91 Page St. } **PROVIDENCE, R. I.** Our processes are strictly up to date and facilities most complete for doing all kinds of refining.
Works, 77-85 Page St. } Specialties: Prompt and good returns.

CASTINGS Gold, Silver, Bronze, Brass, German Silver, Copper and Iron.

L.D. TEL. 2072 L. Supply Jewelers, Silversmiths, Die-makers, Mould-makers, etc. Bronze Forces, Hard Bronze and Iron Shells for Die-cutting Machines. Cast Iron Hub for sinking in Steel Dies. Chandler, Undercut Work, Statuary.

AUGUST GRIFFOUL 313 HALSEY STREET
NEWARK, N. J.



WORKSHOP NOTES AND QUERIES

[Answers are also solicited from our readers to the questions published on this page.]

QUESTION No. 2113.—Jewelers' Soldering Lamps.—Kindly give me a description of some good soldering lamps, suitable for jewelers' repair jobs and for soldering larger articles. J. S.

ANSWER:—There are in use many different devices for soldering purposes. One of them is the glass body, octagonal in shape, for alcohol, with a tube for the wick. The flame is blown with a regular blow-pipe. This lamp is well known to the American



FIG. 1.

repairers and needs no further introduction. There are a number of other devices, some of which are illustrated herewith. The hot blast blow-pipe (Fig. 1), used with an ordinary alcohol lamp, will give nearly



FIG. 2.

double the power that can be obtained with an ordinary straight blow-pipe. One of the most convenient blow-pipes is known as the Fletcher (see Fig. 2), which is fitted with a mouthpiece and a chamber to hold the

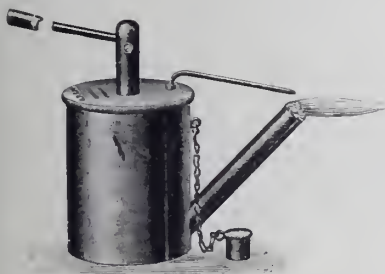

FIG. 3.

moisture. This is easy to use with perfect control. The blow-pipe proper is held like a pencil, the rubber tube enabling one to hold his head so that one can observe one's work while soldering. The blow-pipe can be used for any alcohol flame, and may be arranged for a hot blast by simply changing the end piece. The *Deutsche Goldschmiede Zeitung* shows a soldering lamp and blow-pipe combined (see Fig. 3), which is undoubtedly a cleverly arranged apparatus. The blow-pipe is attached to the cover and can be turned in any direction.

The cover consists of an air chamber, which is filled one-third full with benzine. The lower chamber is used for the alcohol, and is connected with the spout and wick. The wick can be regulated to give a small or a large flame. When blowing into the air chamber through the blow-pipe the air will



FIG. 4.

mix with benzine vapor, which is let out of the chamber through the small tube on top, and passes through the flame, making a very sharp and intense flame. Another blow-pipe, illustrated in the same publication, consists of a detachable point, a bulb to gather the moisture, with a rubber tube and a suitable mouthpiece (see Fig. 4),

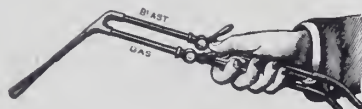

FIG. 5.

making a blow-pipe easy to use and giving the operator a chance to move his head and body during the soldering operations. Where there is gas that can be piped to the work bench, then it is possible to arrange one of the nicest and cleanest ways of soldering—better than can be obtained in any other way. Gas enables one to make use of a regular soldering lamp (see Fig. 5),

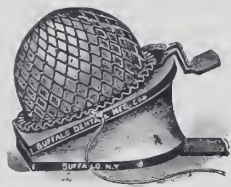

FIG. 6.

which can be regulated to a small flame or one large enough for brazing larger pieces. Those lamps have stop cocks so the amount of gas and air can be regulated. The air may be blown with the mouth for ordinary small soldering, but it is necessary to have a bellows for brazing or soldering large pieces. The Foot blower (see Fig. 6) is very useful for the saving of time in soldering and brazing of any objects. A Foot blower is put under the work bench, connected with the lamp with a rubber tube, and the air necessary can be regulated with

different pressure by means of the foot. When gas is not available a gasoline gas generator can be used to produce gas for soldering purposes, and is used in connection with a foot blower, as shown in Fig. 7.

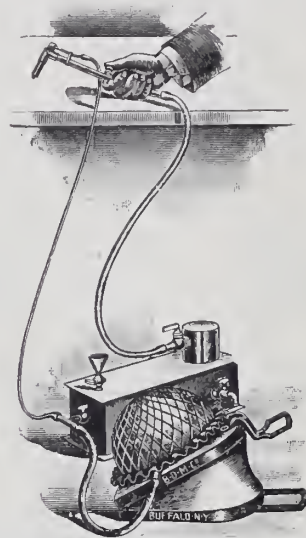

FIG. 7.

This apparatus gives good results, and the expense of operating is small. The whole gasoline outfit looks like an expensive arrangement, but it is not. The combination can be purchased for about \$14.

QUESTION No. 2114.—To Clean Marble.—We have a white marble washstand in the store which has become brown in places. Is there any way in which we can treat it to bring it back to its original color?

C. L. R.

ANSWER:—Make a rather thick paste of four parts, by weight, of soft soap, four parts of chalk and one part of carbonate of soda, mixed in sufficient water. Apply a quantity to the spot, leave for 24 hours, and then wash with pure water. The application can be renewed if necessary. (2) A preparation is patented in France under the name of "La Favorite," which is claimed to give perfect brilliancy very quickly. It will not soil either the hand or the article, and will not leave any odor on copper. The following is the composition for 100 grammes of the product: Wax, two-fourth grammes; oil of turpentine, nine-fourth grammes; acetic acid, 42 grammes; citric acid, 42 grammes; white soap, 42 grammes. (3) Mix burnt lime with soap and water to a thin paste. Then cover the marble article with this mixture and let it stand for about 24 hours to 30 hours, after which remove with lukewarm water.

QUESTION No. 2115.—To Polish Celluloid.—Please let me know of a method of polishing celluloid. H. M. C.

ANSWER:—To polish celluloid, make a kind of putty of hot soap, free from resin, in which equal parts of finely powdered pumice and flour of emory have been mixed.

J. K. Roumain, Baton Rouge, La., contemplates erecting a four-story building on 3d St., at that place. He has also made plans for the building of a jewelry store in Alexandria.

C. DORFLINGER & SONS

36 MURRAY STREET

NEW YORK



Hand-Made Blanks only.
Cut, engraved and etched
glass. Light, medium
and heavy stemware,
tumblers, etc.

The Pairpoint Corporation

NEW BEDFORD, MASS.



SUPERIOR
SILVER PLATED
WARE

RICH
CUT GLASS
WARE

ELECTROLIERS
GAS PORTABLES, ETC.



No. 4935.—Smoking Set.

No. 692.
Whiskey Jug.
"Uncatena."

BRANCHES
38 Murray Street - - - NEW YORK CITY
717 Market Street - SAN FRANCISCO, CAL.
485 St. Catherine Street - MONTREAL, P. O.



LA VIGNE TEASPOON



LA VIGNE TABLESPOON



LA VIGNE MED. FORK

The latest and newest in ROGERS FLATWARE

HAVE YOU SEEN IT?

Bright or French Gray. Sample dozen on ap-
proval. Write for prices and terms.

JOSEPH IRONS, 35 Maiden Lane



"Wild Rose," No. 122—14-inch
Ice Cream Tray

Irving Cut Glass Co. Inc.

Manufacturers of

Artistic Cut Glass

HONESDALE, PA.

F. W. REICHENBACHER
New York Representative
No. 25 WEST BROADWAY, Room 43

Established 1879

Manufacturer of

LOUIS W. HRABA Fine Leather Goods

29 East 19th St., New York

Exclusively for the Jewelry Trade

CROUCH & FITZGERALD



Jewelry Trunks and Cases

177 Broadway,
Bet. Cortlandt
and Dey Sts.
688 Broadway,
723 6th Ave.,
New York.



LEMAIRE OPERA GLASSES

LEMAIRE FIELD GLASSES

Best in the World. Used in the Army and Navy.

SUSSFELD, LORSCH & CO., Importers

37 MAIDEN LANE, NEW YORK

MARQUE DE FABRIQUE



All Genuine Glasses
Bear This Mark
Large Variety in All
the Latest Styles

THE CONNOISSEUR

Devoted to Art Pottery, China, Marbles, Bronzes, Cut and Decorated Glass Ware, Bric-à-Brac, Lamps, Art Metal Wares, Fancy Goods and Kindred Lines.



Exhibition of the Work of Augustus Saint-Gaudens at the Metropolitan Museum of Art, New York.

THE exhibition of the work of Augustus Saint-Gaudens, which was opened at the Metropolitan Museum of Art, New York, on March 3, has proved such a great attraction to lovers of sculpture that the authorities of the Museum have decided

themselves of the opportunity given them for a private view of the works of this distinguished sculptor. They were received by Joseph H. Choate and other members of the Board of Trustees.

The Museum's own collection of sculp-

German Historical Society Creating a New Vase and Reviving an Old Roman Art.

ACCORDING to Consul William J. Pike, of Kehl, there is about to appear in the market a new kind of a richly embellished vase to be called *terra sigillata*, which is of interest from a historic and artistic point of view, leading him to summarize a description from a German trade journal, as follows:

Recently, in the excavation of Roman



GENERAL VIEW OF THE HALL OF THE METROPOLITAN MUSEUM OF ART, IN WHICH THE WORKS OF SAINT-GAUDENS ARE EXHIBITED.

to continue the exhibit during the month of April. The illustration reproduced herewith shows the main hall of the Fifth Ave. side of the Museum, where the collection is on exhibition.

The collection was arranged by a special committee under Chairman Daniel Chester French. A reception was held on the opening night to the members of the Museum and fully 2,000 people availed

themselves of the opportunity given them for a private view of the works of this distinguished sculptor, while it does not by any means show all the work of Mr. Saint-Gaudens, fills the hall. It is a most notable showing and is representative of the genius and untiring industry of one man during a lifetime of only 60 years.

Jeff D. Crane & Co., Gulfport, Miss., have sold out to A. E. Morlan.

ruins, a certain beautiful vase, called in Latin *terra sigillata*, was unearthed. This has come to the attention of a historical and archaeological society in Metz, Lorraine, which became so interested in the vase that it approached a manufacturing firm with a view of ascertaining whether it would be possible to manufacture an imitation of this unique vase, because the society wished to present each of its mem-

Marine Scenes

Underglaze
Enamel Colors

The latest production of the *Royal Doulton* factories. Exquisitely enameled in rich colors.

Sole Agent

W.S. Pitcairn

44 Murray Street
New York

Write for Booklet, "Quaint Bits of Royal Doulton"



SERIES No. D2872

1. Snap complete.
2. Outside of snap.
3. Inside of snap.

The E. P. H. Patent

NON-PULL-OUT Neck Chain Snap

is a patented snap that insures the wearer against loss of

CHAIN or CHARM
for it positively will not pull out

Made in 10 and 14 Karat Gold and
in Gold Filled.

Can be had of the following Wholesale Selling Agents:

Messrs. W. Green & Co.,
81 Nassau St., New York
M. Sickles & Sons, Philadelphia
E. A. Cowan & Co., Boston
E. & J. Swigart, Cincinnati
Swartchild & Co., Chicago
Nordman Brothers, San Francisco
Leonard Krower, New Orleans
A. Walker Co., Providence, R. I.
Bauman-Massa Jewelry Co., St. Louis
H. S. Meiskey Co., Lancaster, Pa.
The Edw. Lehman Jewelry Co., Denver, Col.

PRICES.

14 Karat—Small, \$7 per doz. net
Large, \$7.50 per doz. net
10 Karat—Small, \$6 per doz. net
Large, \$6.50 per doz. net
Gold Filled—Small, \$2 per doz. net
Large, \$2.25 per doz. net



My Stock

of exquisite and unusual effects in FANS is, as usual, the Most Complete in this country.

Louis Steiner

FANS And Novelties for the Jewelry Trade

520 and 522 Broadway
New York

New York Tortoise Shell Co.

13 EAST 30TH STREET,
Just East of Fifth Ave.

NEW YORK

Manufacturers of Fine

TORTOISE SHELL GOODS

Repairing given prompt attention.

The St. James

Cor. Walnut and 13th Sts., Phila., Pa.

THE IDEAL HOTEL OF
THE QUAKER CITY

A spacious fire and burglar proof safe has been provided for the convenience of the trade. Palatial rooms with bath \$2.50 per day and up. Rooms without bath, (running water) \$2.00 and up.

EUGENE G. MILLER, Mgr.

JACOT MUSIC BOX CO.

MIRA MUSIC BOXES
AND MIRAPHONES

39 UNION SQUARE - NEW YORK.

bers with a copy of one of these old Roman relics. The manufacturer who was interviewed also became very much interested in this piece of art, being himself an antiquary, and offered his services in trying to imitate this skilfully and dexterously worked out creation of art.

The first process was naturally the study of the composition and the method which had been used by the Romans in embellishing the original, which was a more difficult matter than imitating the exact form. Further, to produce the artistic effect a burning process was necessary, which in the first experiments with the material used made the vases so brittle that they were found to be impracticable. Should further experiments, however, overcome this obstacle, the firm will not only manufacture a sufficient number for the members of the society, but place the same upon the market.

Since similar vases, found only in museums, have already created so much attention from the world of art and admirers in general, it is quite certain that it will be one of the best novelties of real worth which has appeared for some time.

Address of President C. Z. Rowe before the Indiana Retail Jewelers' Association.

WE have met here to-day hoping to better our conditions by organizing. It is unnecessary for me to say we are greatly in need of organization, for without it our hopes will be blasted. I have come to that realization long ago, and have often wondered why we did not get together.

This is the first annual meeting of the Indiana Retail Jewelers' Association. We met in this city the first day of last August under rather discouraging circumstances, there being only a few of the craft present. Notwithstanding that we effected an organization. I believe the roll called for 17 charter members. Out of this little bunch has grown a membership of 80. This certainly is encouraging—to know that our work has not been in vain, and I want to tell you that 80 enthusiastic members installed in so short a time begins to look like business. This is evidence very plain to my mind that the craft is ready and anxious to do something. The retail dealers for a long time have stood idly by, making no resistance. They have seemingly been unconscious of what was going on about them. Thus the unfair competition, as we term it, has gradually crept in while we were apparently asleep, and you can see we are, to some extent, to blame ourselves. We can't blame the catalogue houses—they saw an opportunity and made hay while the sun shone. In order to relieve ourselves of these undesirable conditions we must unite, for "In union there is strength," "United we stand, divided we fall."

Our constant endeavor should be to keep and maintain a good, hustling organization, and be able to secure a decent living compensation for our labors, realizing the fact that without work and hustling our labors are lost.

We must first foster a social development of the craft, promoting and maintaining honesty and a friendly feeling toward one another. I would like to see every fellow, as far as is possible, put forth his best efforts and boost this work, showing his own force of mind and character. S. O. Bigney says, "Eternal hustle coupled with honesty and integrity is the just price of success."

It is up to everyone of us—we owe it to ourselves—to organize one stupendous movement, both social and economic, constituting one of the greatest revolutions in the history of the retail jewelry business. I will ask that whenever anyone of you has anything of value to the association make it known by all means. Let us have it just as you see it, and it will be gladly accepted for all it is worth.

I wish to take up as little time as possible and in order to expedite matters I am going to speak briefly. I will first call your attention to some of the existing evils that now confront us. It might be well to start at home for there are many

disagreeable features that come up in our own ranks and need fixing. We have a certain kind of competition, or rather a certain class of fellows, who give as much or more trouble than the catalogue houses and department stores.

These fellows are not justly entitled to the name of jeweler and watch repairer. Mainsprings 50 cents, watch glasses 10 cents, and so on all along the line. They also buy the cheapest imitation material which they can find in the market, and resort to using brass for roller jewels and fasten cook and foot jewels with soft solder, especially when they loosen the screws. I recently took in No. 941 Hamilton for repairs and found the balance staff and roller were held in place with soft solder, and it also had a brass jewel pin. I am at a loss to know how to handle such fellows. As a rule they are always moving about and the dear public gets the experience. I sometimes think that if it were possible to bring such a thing about, that legislation along this line would be a good thing, compelling the craft to bump up against a State board of examiners and prove their competency. We would then have a much more desirable class of business men and mechanics, and the general public, as well as ourselves, would profit by it.

Another very undesirable thing is a protracted fight among dealers. Frequently this fight continues until one or the other or both go to the wall, losing their friends, financial standing and also their business standing in the community in which they do business.

Whenever the crash comes it hits hard and the conditions are often serious. It means that whenever a man starts down hill every fellow gives him a kick. I wish to mention another matter before dropping this subject.

The term commonly used to designate a legitimate jeweler is one who maintains a bench and keeps a stock of watches, clocks, jewelry and kindred goods.

Then there is the fellow who has the bench only. Many of us started that way, and in either case he may or may not know very much about the mechanical end of the business. However, if this is his principal vocation, he undoubtedly would come under the term used.

I hope none will misunderstand me. I do not wish to be arbitrary or radical in my views, but simply mention these facts as food for thought.

I will now speak of the retail jobber and also the manufacturer, the one that does not care what channels his goods pass through so long as the money comes his way. No doubt many of us patronize jobbers who sell at retail. We have had no means of knowing what their methods are.

The benefits derived by organization will place us in a position to know from whom to buy. We will be directly connected with one another, and with a mouthpiece of our own will be able to relieve ourselves of the existing evils.

I reported a matter that recently came under my observation. I found a 1908 catalogue in a drug store in my home town sent out by a Cincinnati jobber. I asked for the catalogue and got it and reported my finding to several of the different State organization's officials, and I believe this house has since been pretty thoroughly aired. I am told they make a business of retailing and have swelled up on themselves regarding the \$8,000 worth of business they did at retail last December, and they want to know why they should give up this nice income. Now they have the audacity to expect the patronage of the legitimate retail jewelers.

I am informed there are two jobbing houses in Cincinnati that make a business of retailing and I hope the legitimate dealers will see that there is "something doing" in such cases.

Henry Bolte, Atlantic City, who has been critically ill with erysipelas and pleurisy, is reported to be out of danger and steadily improving. An early recovery is now looked for.

Mrs. Florence Leggatt, claimant to a widow's share of the estate of Jacob Muhr, formerly of the house of H. Muhr Sons, who died leaving a large estate about two years ago, filed exceptions in the Orphans' Court last week to Judge Lamorelle's decision dismissing her claim. She avers that there were errors in the findings both of law and fact.

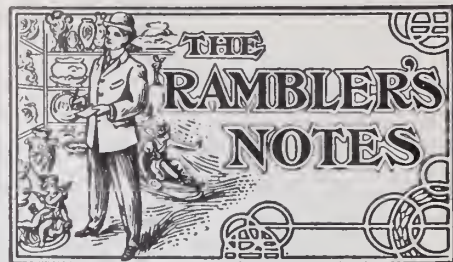

ATTRACTIVE SUBJECTS IN BRONZE.

AMONG the many attractive exhibits seen recently at the Fifth Ave. salesrooms of Tiffany & Co., New York, was a life-size statue of an Indian in the act of shooting at an imaginary eagle. The Indian is shown reclining on his back and holding a massive bow against the soles of his feet. The bow is drawn taut. "The Primitive Marksman" is the title given the work. It is the work of the sculptor, Fernando Miranda.

NEW BRONZES BY JOHN ROGERS.

A BRONZE group by John Rogers, entitled "Ichabod Crane and the Headless Horseman," is on exhibition at the Metropolitan Museum of Art, New York. The study shows two horsemen, one in an attitude of fright, grasping his horse's mane, the other a shrouded figure holding a pumpkin jack-o'-lantern in front of him. "The Wounded Indian," by the same sculptor, shows an Indian beneath the feet of a rearing horse. Mounted on the horse is another Indian looking backward, and in the act of shooting an arrow at an enemy. The group is most carefully worked out.

NEW OFFERINGS IN POTTERY AND ART GLASS

LING & STEWART have on exhibition at their salesrooms, 66 West Broadway, New York, a line of basaltine ware which contains a number of exhibits of interest to the trade. The line includes mugs, vases, plates, cups, etc., some of which have a blue glaze and against this are shown mythological and classical figures, while others are finished in a dead black. The line also contains plates and cups finished in deep red and black, showing woodland scenes. The line of cut glass shown by the same firm includes novelties in sugar and cream sets, salad bowls, compotes and vases.

AN ATTRACTIVE CLOCK SET.

AMONG the attractive novelties in fine clocks seen at the salesrooms of Harris & Harrington, 12 Barclay St., New York, is a clock set in gold work effect. The central piece is made up of a white marble base on which rests a glass case heavily embellished in gold. About the face of the clock is a heavy flower wreath in gilded effect. On the top of the case is a cupid playing a large cello. The little god is looking over the edge of the case as if trying to read the time. The two candelabra are made in the form of rose branches and are held by two cupids seated on pedestals.

THE RAMBLER.

No. 7

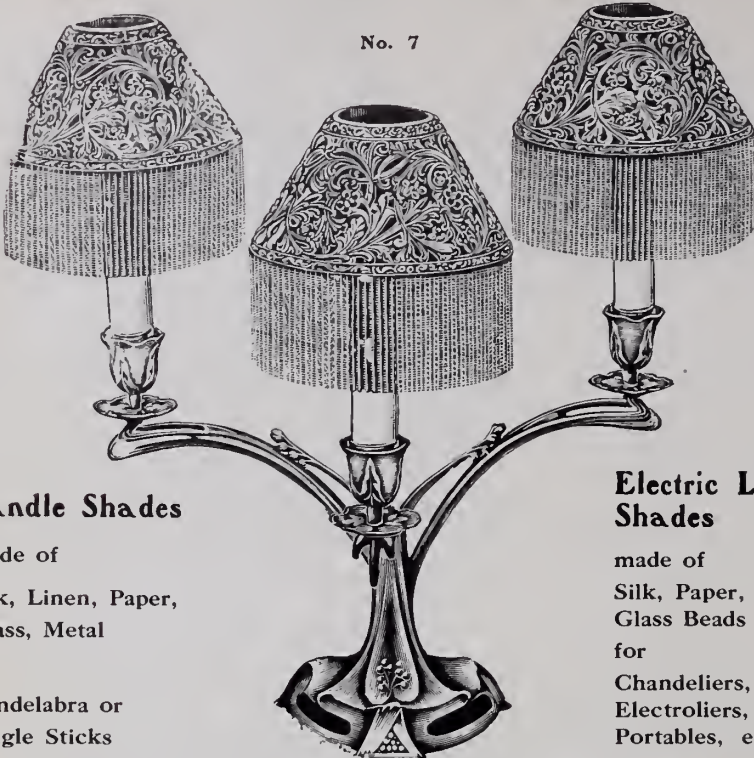

Candle Shades
made of
Silk, Linen, Paper,
Glass, Metal
for
Candelabra or
Single Sticks

**Electric Light
Shades**
made of
Silk, Paper,
Glass Beads
for
Chandeliers,
Electroliers,
Portables, etc.

THE HOHENSTEIN COMPANY
Makers and Importers
Candle and Electric Light Shades
Write for New Catalog 1908 28-30 Waverly Place, NEW YORK



Light Lofts To Let
IN THE NEW
GIBSON BUILDING
N. W. Cor. John and Gold Streets
NEW YORK

About 4,200 square feet for Light Manu-
facturing or Show Rooms.
ELECTRIC ELEVATOR AND STEAM HEAT
All lofts wired for power. Apply to your
Broker or on Premises.

These well-known Razors, the quality of which is warranted, possess this great advantage, that they may be used for ten years before they require actual sharpening. Before using them it is necessary to rub them on good leather strop. Le Coultre's Stropps (to be had with the Razors) should be used in preference to others.

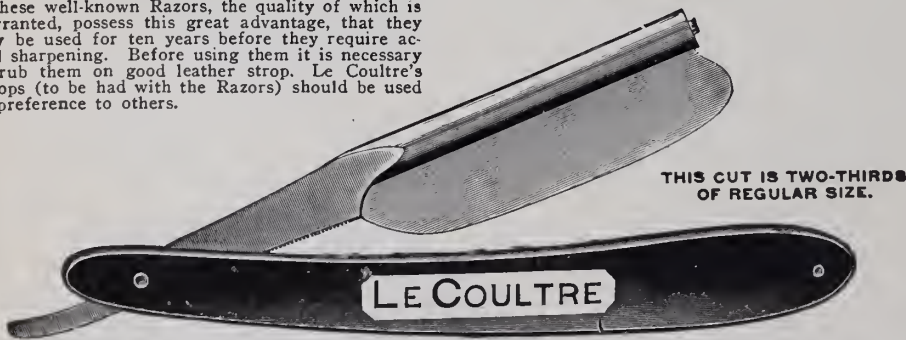

THIS CUT IS TWO-THIRDS OF REGULAR SIZE.

“SPECIAL”—Single Razors for Jewelers' Travelers at trade price.

MATHEY BROS., MATHEZ & CO.

Send for Price-list.

Sole Agents, 21 & 23 MAIDEN LANE, N. Y.



Correspondence Solicited

TRADE  MARK

ESTABLISHED 1850

HAND BAGS

We have a very extensive collection in all desirable leathers

C. F. RUMPP & SONS
FINE LEATHER WARE

Fifth and Cherry Streets
PHILADELPHIA

New York Salesrooms, 683 and 685 Broadway

REMOVAL NOTICE

MABIE, TODD & CO.

Gold Pens

PENCILS, HOLDERS AND CASES
SWAN FOUNTAIN PENS

HAVE REMOVED TO
SILVERSMITHS BUILDING
15-17-19 Maiden Lane, New York

PATENTS

obtained on inventions and designs. Trade-
marks, prints and labels registered.

R. W. BISHOP,
ATTORNEY-AT-LAW,
908 G Street N. W., Washington, D. C.

CRUCIBLES.



Jewelers' Supplies,
Etc.
Established 1850.
J. & H. BERGE,
95 John Street,
NEW YORK.



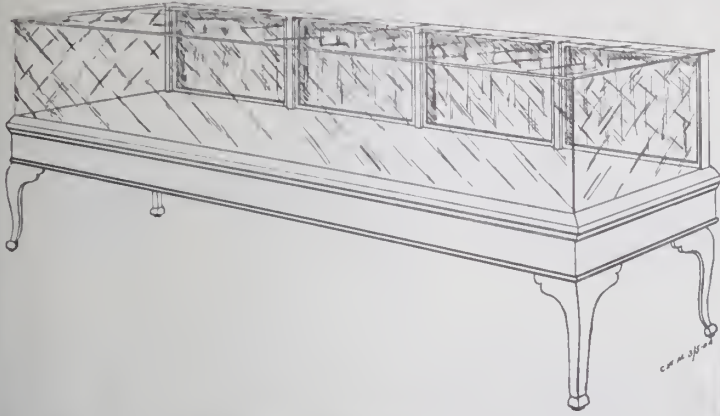

"FOR A QUARTER OF A CENTURY"

We have been manufacturers of

High-Grade Jewelry

Fixtures

Correspond with us before placing your orders

ALEXANDER H. REVELL & CO.

Rees, Dayton, Eastman and Hawthorne Streets,
Chicago, Ill.



3020—18 in. Diameter, Top Hanger

UNIQUE ART GLASS AND METAL CO.

46 PARK PLACE, NEW YORK

Makers of High Grade

Art Glass Dining Room fixtures

Lamp Shades, Electric Shades and Portables

CALL IN AND SEE OUR BEAUTIFUL LINE
OF PRODUCTS AT POPULAR PRICES

Also an Elegant Line of

RICH CRYSTAL CUT GLASS AT FACTORY PRICES

DAN I. MURRAY

Established 1880

AMERICA'S LEADING JEWELRY AUCTIONEER

The only man in the world who was able to conduct an auction sale six months on Maiden Lane, New York, the jewelry center of the world, selling an average of over \$2,000 per day at a profit over cost. I did it and have the record to prove it.



DAN I. MURRAY

I thought of retiring from the auction business as I found the average jeweler a man who was easily fooled by fakirs in the auction business, that he employed almost any kind of an auctioneer without first investigating the man's character or ability, and after employing one of these fellows, who, of course, made a failure of his sale and further ruined his good name, I would be appealed to to come and help him out. I, of course, refused in many cases, as it is hard to raise a man from the dead to life again.

The public are not fools, they are just as wise as you or I, Brother Jeweler. What the public want to-day is a square deal, they want a man to present to them facts and show his perfect knowledge of any piece of goods offered for sale by a perfect description of how the goods are made, etc. He cannot do this unless he is a practical manufacturer and a gifted orator. This is my lot. I have gone through every branch of the jewelry business, both manufacturing and importing, obtaining thereby a perfect knowledge of imported goods as well as American manufactures.

Now read these few lines from the largest importing house in America. I can show the original letter and will be pleased to do so to any person desiring to read it. Here are the words they wrote me after I refused to conduct a sale offered me after two other auctioneers had tried and failed:

"Dear Mr. Murray—You have reasons to be disgusted in some ways with the auction business, as there are so many fakirs and unscrupulous fellows in it, and they are the fellows who hurt the business of the good, straightforward ones like yourself, as they make a failure of so many sales that people become disgusted with auctions."

Now read these few words from a good, square auctioneer who is honest and not afraid to tell the truth. Here are a few words from his letter:

"Mr. So and So says he can sell more goods than you can. This, I know, Mr. Murray, is not true, as I have worked on the stand with you both, as well as with many other auctioneers. I have gone 500 miles to hear noted auctioneers sell, but you are the King of them all, and you are, moreover, the greatest auctioneer in America to-day, and, I think, in the world."

I have the original of this letter to show any one who is entitled to read it. Brother Merchant, if you were about to die would you pick up any kind of a doctor? No, you would want the best in the land. If you were in trouble and about to lose your home, your good name, etc., would you employ any kind of lawyer who advertised? No, you would get the best, no matter what the price would be. Why don't you do the same when you employ an auctioneer, as he is the man to save your home, your money and your good name?

Think it over, then write me to either office. Three first class assistant auctioneers—charges same as for one or two men, I personally conduct all large sales.

MY ADDRESSES ARE

**3 Maiden Lane, NEW YORK; 151 Wabash Ave., CHICAGO. or 512 Race St., CINCINNATI, O.
Also 1172 Sutter St. SAN FRANCISCO, CAL.**

A SHEAR

that will cut any kind of design to perfection. Better have a pair—they are mighty useful.

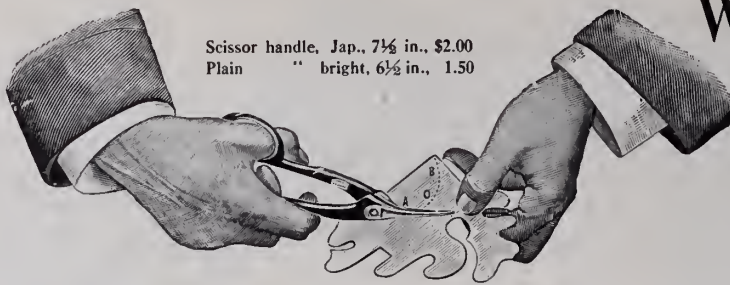

Scissor handle, Jap., 7½ in., \$2.00
Plain " bright, 6½ in., 1.50

William Dixon,

Incorporated

39 John St., New York

Formerly

F. W. GESSWEIN COMPANY

LEES & SANDERS,

DON'T BE AFRAID OF THE FREIGHT
IT WILL PAY YOU TO SEND

SWEEP SMELTERS, BIRMINGHAM, ENG.

WM. F. RENZIEHAUSEN CO.

'Phone 3759-R.

43-47 Oliver Street, NEWARK, N. J.

Gold and Silver Refiners

PROMPT RETURNS MADE FOR ANY MATERIAL CONTAINING PRECIOUS METALS
DEALERS IN GOLD AND SILVER, AND ROLLERS OF STERLING SILVER

Gold and Silver Anodes a Specialty



WE BUY

Old Gold and Silver Filings, Polishings, Sweeps, Hand Washings, etc. We will make accurate valuations and hold consignment subject to your acceptance. If valuation is not satisfactory, we reship to you at our expense.

WE PAY FOR OLD GOLD:

22 K. 88c. per dwt.	12 K. 48c. per dwt.
20 K. 80c. " "	10 K. 40c. " "
18 K. 72c. " "	8 K. 32c. " "
16 K. 64c. " "	6 K. 24c. " "
14 K. 56c. " "	4 K. 16c. " "

MARKET RATES FOR SILVER AND PLATINUM.

Try us and you will Appreciate our Squareness, Promptness and Accuracy.

T. B. HAGSTOZ, Ltd., Main Office, 709 Sansom St., Philadelphia. Pa.
SMELTERS, ASSAYERS, REFINERS.

WE SELL

Gold, Silver and Platinum, various qualities, rolled flat or drawn to wire of any gage.

PRICES OF ALLOYED GOLD:

8 K. 42c. per dwt.	14 K. 66c. per dwt.
10 K. 50c. " "	16 K. 74c. " "
12 K. 58c. " "	18 K. 82c. " "

Gold and Silver Solder, either from formulas furnished, or our own. "T. B. H." Alloy, 26c. per oz. Guinea Gold, 75c. per lb. Shot Copper, 40c. per lb. We will send tables for alloying without charge. They save figuring.

PLATINUM AMERICAN PLATINUM WORKS

NEW YORK OFFICE 41 Cortlandt Street NEWARK, N. J.

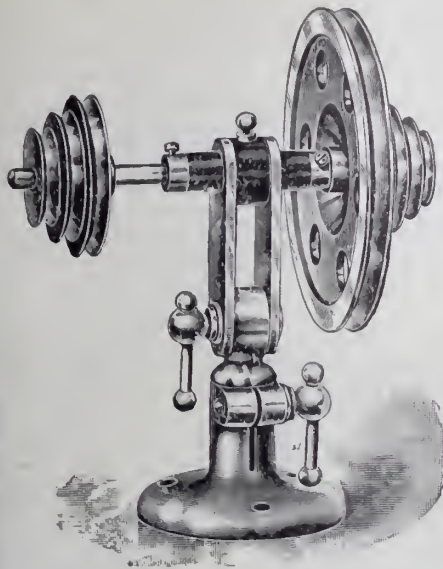

A New Patent Speed Wheel Countershaft

made by G. Boley, all polished and nickel plated, being made with hard bronze bearings which insure perfectly true running, with attachment to hold all wheels for grinding or polishing.



Robbins' Upright Roller Remover

With Improved Revolving Disk and Plunger

Flat bottom, which sets firmly on the bench. You cannot break pivots with this tool, as it is very easily adjusted for any size from jewel series to the largest size. Single or double roller. Nickel-plated. Price, \$2.25.

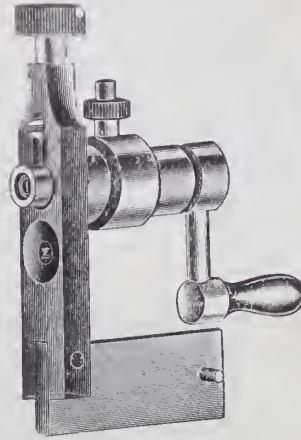

Robbins' Latest Improved Patent Mainspring Winder

Does away with changing of barrels, which alone is a time saver.

Nickel plated, price \$2.00. Directions with each tool.

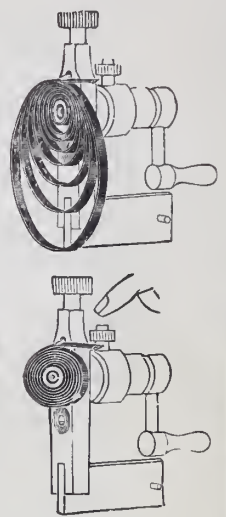

ASK YOUR
JOBBER
FOR SAME

SOLE AGENTS:

77 John Street,
New York City

HENRY ZIMMERN & CO., Inc.

Exclusive Wholesale
Distributors for
U. S. and Canada.



(Pat. applied for.)

Balance Hole Jewels Size of the hole numbered on setting. Saves time and duplication. You can order just what you want. If your jobber does not handle them, send to us. Made for all kinds of American movements.

Ruby and Sapphire, \$1.25 per dozen

THOS. J. JUZEK & CO., Elgin, Ill.

JOHN AUSTIN & SON

Assayers, Refiners and Smelters

74 & 76 Clifford Street

PROVIDENCE, R. I.



We Do Our Own Smelting.



L. LELONG & BRO.

Gold and Silver Refiners, Assayers and Sweep Smelters

S. W. Cor. Halsey and Marshall Sts., NEWARK, N. J.

Prompt attention given to Gold and Silver Bullion.

SMELTING FOR THE TRADE.

UNITED STATES SMELTING AND REFINING WORKS

L. & M. WOLLSTEIN

16 JOHN STREET, NEW YORK

SWEEP SMELTERS AND ASSAYERS

Dealers in Gold and Silver Assay Office Bars. HIGHEST and MOST PROMPT RETURNS made for Sweeps and all kinds of Waste containing precious Metals.

HIGHEST PRICES PAID FOR OLD GOLD AND SILVER

Manufacturers of STERLING SILVER.

Importers of PLATINUM.

Ore and Bullion Assays a Specialty.

A UNIQUE RECORD IN JEWELRY AUCTIONEERING

5 SALES IN 10 YEARS FOR ONE OF AMERICA'S
LARGEST JEWELRY HOUSES

TWO
TO
SIX
SALES
FOR
HUNDREDS
OF
JEWELERS

EVERY
ONE
A
SUCCESS



NO
CLIENT
OF
MINE
HAS
EVER
ENGAGED
ANOTHER
AUCTIONEER
IF I
COULD
ACCOMMODATE
HIM

THE MERMOD-JACCARD-KING CO., OF ST. LOUIS, MO., is one of the largest and most reliable jewelry houses in the world. They carry only high grade goods of standard quality, and they consider their reputation for honesty and reliability their most valuable asset. The policy of this firm in regard to auction sales and auctioneers is a beacon light for the trade at large.

I have made five sales for this firm in the past ten years, and each sale has not only been more successful than its predecessor, but was followed by a large permanent increase in the business of the house.

Just closed Nine Weeks' Sale for the M. Scooler Co., New Orleans. If you are overstocked, or want to liven up your trade, or if for any reason you wish to realize promptly and profitably on your stock, and at the same time increase your future business, write at once to

S. MARTIN, Auctioneer for Reliable Jewelers Only

Long Distance Telephone, Lake 663

840 Summitt Avenue, Milwaukee, Wis.

THE JEWELERS' CIRCULAR

WITH WHICH ARE CONSOLIDATED

THE HOROLOGICAL REVIEW,

THE JEWELERS' WEEKLY,

THE JEWELERS REVIEW

Copyright 1908 by
The Jewelers' Circular
Publishing Company.

11 John St., Corner Broadway, New York.

Entered as second-class matter at the New York, N. Y., Post Office.

40th Year.

WEDNESDAY, APRIL 29, 1908.

Vol. LVI., No. 13.



A Fine Presentation Set, Showing a Replica of the Warwick Vase.

(See Text on Page 45.)

ALVIN PLATE



BRIDES BOUQUET.

Immediately after Easter there is an unusual number of weddings.

Silver is always thought of when wedding presents are in demand.

This year there will be many who feel they cannot afford STERLING SILVER flat ware, and if they know of the Alvin PLATED Ware they can give flat ware that will look like Sterling and wear a lifetime.

"The Lily" and "The Brides Bouquet" patterns are of the best silver plated ware made, and in patterns heretofore associated only with Sterling Silver ware.



LILY.

ALVIN MFG. CO

SILVERSMITHS

NEW YORK

“It's the little things in life that count.”

The reason why Fahys Bristol Case is the leading 25-year case, is because when it was first placed on the market our experts had considered every feature, and we embodied more actual gold value in this case than any other 25-year case.

The most artistic designs were selected and have constantly been added to. The finish was the best.



B 3447

Added to these features it is made with solid gold ball-bearing bow and our patent one-piece pendant, which eliminates all solder. This patent is controlled by us exclusively.

These “little things” are what make Fahys cases superior to other makes.

There is little wonder that every Bristol Case sold ensures a satisfied customer for the retail jeweler. It pays to handle the best in every grade.

JOSEPH FAHYS & CO.

New York

Boston

Chicago

San Francisco



TO CORRECT THE RUMOR connecting our name with the financial troubles of Chas. F. Wood & Co., Diamond Jobbers, of 1 Maiden Lane, New York,

WE MAKE THE STATEMENT

That we are an entirely different firm and in no way connected with that house.

J. R. WOOD & SONS

DIAMOND CUTTERS

21 Maiden Lane, Corner of 170 Broadway .

NEW YORK

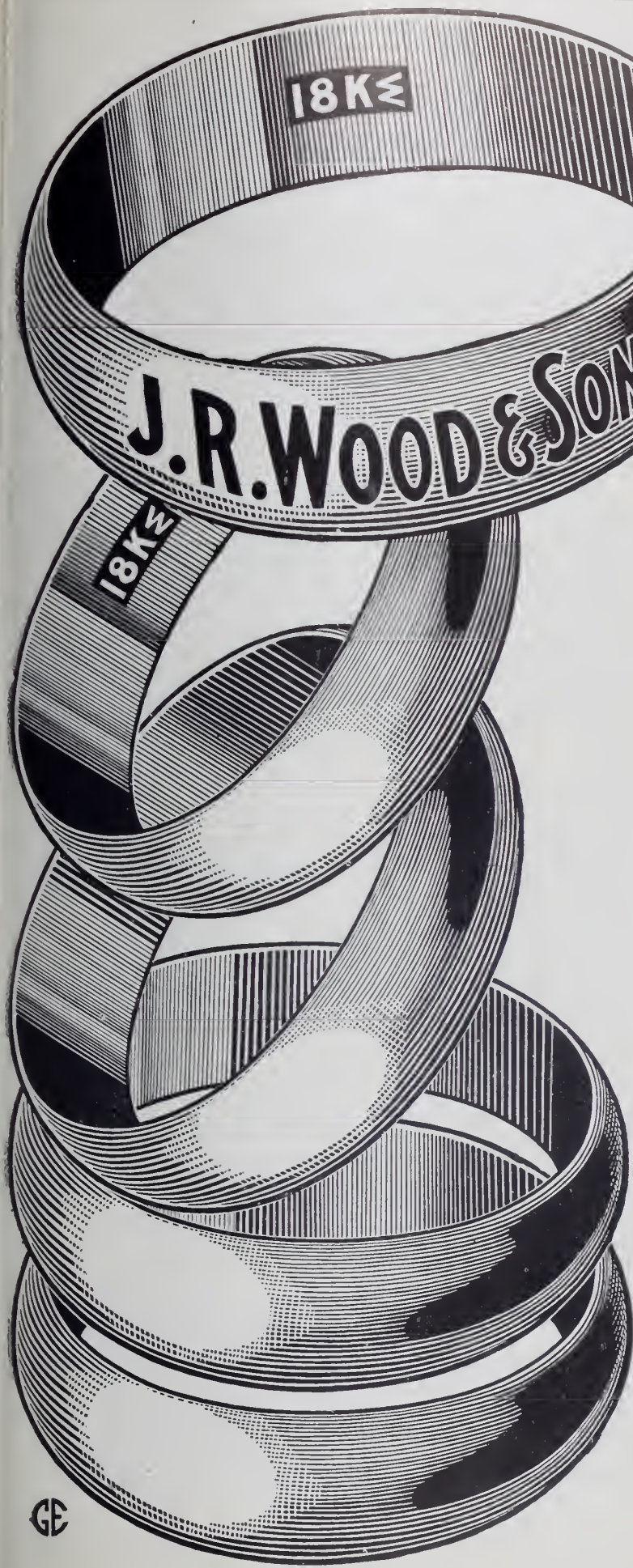

TO CORRECT THE
RUMOR connecting
our name with the
financial troubles of Chas.
F. Wood & Co., Diamond
Jobbers, of 1 Maiden Lane,
New York,

WE MAKE THE STATE-
MENT

That we are an entirely
different firm and in no
way connected with that
house.

J. R. WOOD & SONS

WEDDING RING MAKERS

2 Maiden Lane Corner of 170 Broadway
NEW YORK



The Big Dipper

Will Dip Up Profits For You



THE
BEST IN EVERY
GRADE

CHICAGO
701 Heyworth Bldg.

Ask your Jobber

NEW YORK
Maiden Lane

STAR WATCH CASE CO.

LUDINGTON, MICHIGAN

COPYRIGHTED BY T. F. KENNEDY.



YOU
 CAN SECURE THAT
 CLASS PIN ORDER
 BY SHOWING
 OUR DESIGNS AND SAMPLES.
 WE ARE HEADQUARTERS.
 WRITE TO EITHER FACTORY.
 WENDELL & COMPANY,
 103 AND 105 WILLIAM ST.,
 NEW YORK.
 57 WASHINGTON ST.,
 CHICAGO.

WENDELL'S PERFECT SAFETY CATCH

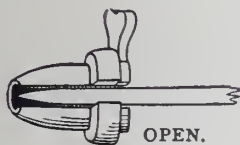

SETS CLOSE TO BODY OF PIN.
 PROTECTS POINT OF PIN TONG.
 HANDILY LOCKED AND UNLOCKED.
 ABSOLUTELY SECURE.

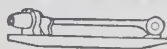
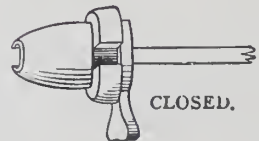

Phesay's Two-In-One Soldering Tweezer

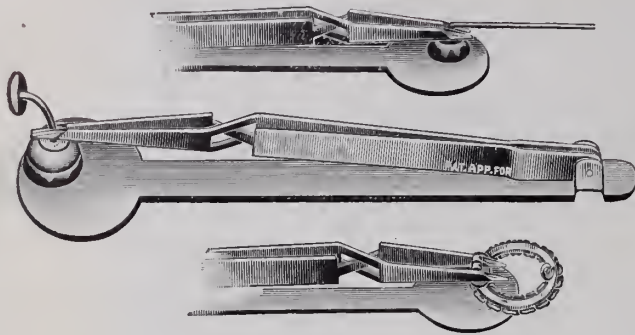

(Patent Applied for)

For Soft Soldering all kinds of Backs, Joints, Catches, etc., on Jewelry
Saves Time

DIRECTIONS:—Hold Tweezer in left hand. Open it out straight by swinging disk arm down. Press top part of Tweezers above interlocking point, to open jaws. Take hold of joint, catch or "Back" with these jaws and fill same with solder as usual; retain joint catch or "Back" in these jaws. (They hold same automatically). Swing disk arm back to former position, place article to have this joint catch or "back" soldered on it on the disk. Then press top part that is holding the joint catch or "Back" down gently and firmly, until it holds joint catch or "Back" on that part of the piece of Jewelry that it is to be soldered to. Apply flame as usual.

By using Phesay's Two-in-One Soldering Tweezer the joint catch or Back is handled only once.

SAVES TROUBLE.—Phesay's Two-in-One Soldering Tweezers will solder plum and true. Will not let article slide when solder flows. Will hold pieces of jewelry with rounded stones or flat surfaces with equal firmness.

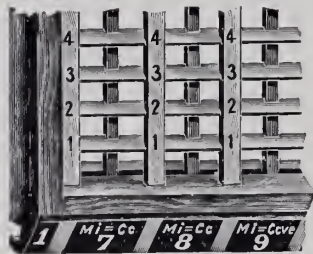

Top View, Showing Skeleton Frame of Drawer. Accumulation of dust and chips is impossible.

Improved Turning and Jeweling Attachment No. 33

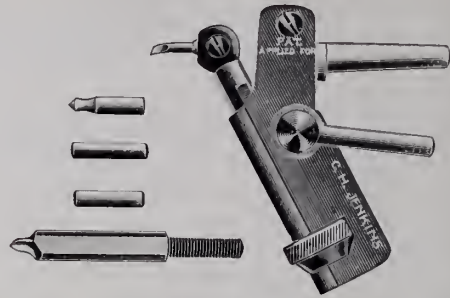

New Features

Adjustment for alignment, fine feed, with direct connected screw. Positive binder operated by slight movement of the thumb or finger. Cutters may be changed quickly. No small projecting parts to become lost or broken. Special cutters can be made from wire.

And Other Good Points

One tool may be used on different makes of lathes by simply changing tapers. Can be changed quickly.

All Standard Tapers in Stock

Each attachment is furnished with two cutters, one burnisher and two blanks. In ordering, please give name and size of lathe. **Price, each, \$4.50**

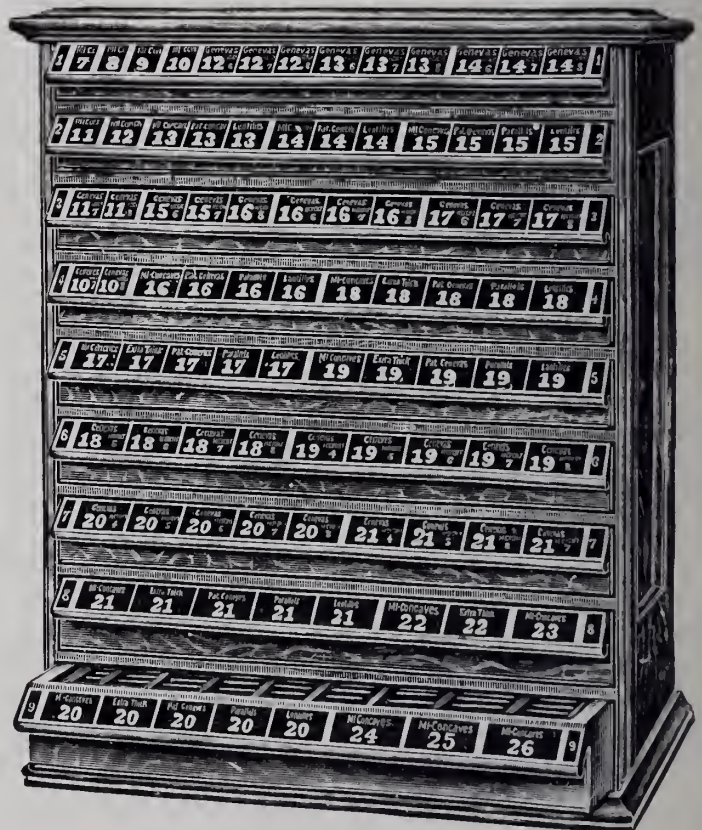

Echarco Watch Glass Cabinet No. 15 (Patented)

Price, each, \$16.00

This cabinet has many new features not found in any other. Novelty and usefulness are the chief arguments in its favor.

CONSTRUCTION AND MATERIAL.—The cases are made of oak, finely finished and of attractive appearance. Sides are paneled. Partitions of basswood and put together in best manner possible.

PARTITIONS are skeleton, preventing accumulation of dust, chips, etc.

BOTTOMS of cabinets are hollow to receive chips, dust, etc.

ARRANGEMENT FOR GLASSES.—The 9 drawers contain 1,547 spaces to hold glasses in upright position.

Labeling of drawers as shown in cut is on the pulls of the drawers and done in gold bronze on black background.

DIMENSIONS.—24 inches wide, 29½ inches high, 12 inches deep; weight, 45 lbs.; with packing case, 75 lbs.

The construction of drawers, the arrangement of partitions to economize space and weight, and the novel method of showing contents on drawer-pulls are all prominent characteristics and extremely well thought of.

FOR SALE BY ALL JOBBERS IN THE UNITED STATES AND CANADA

HAMMEL, RIGLANDER & CO. 47-49 Malden Lane
New York

ONE
AND ONLY ONE
WADSWORTH 20-YEAR CASE

REMEMBER

THAT we make ONE LINE—and only one line—of 20-YEAR CASES.

THAT this one line is THE BEST on the market for the price.

THAT QUALITY AND STYLE are consistently maintained.

THAT the policy of ADVANCE and improvement has suffered no abatement.

THAT new and attractive DESIGNS continue to be added as heretofore.

THAT safety lies in buying the WADSWORTH 20-YEAR CASE.

A WORD to the wise is sufficient.

The WADSWORTH
WATCH CASE
COMPANY

NEW YORK
49 Maiden Lane
CHICAGO
Columbus Building
SAN FRANCISCO
717 Market Street

Factory: Dayton, Ky.

THE "400" SIZE

THE BEST, THE SMALLEST,
THE HANDSOMEST
LADIES' AMERICAN WATCH



"The Molly Stark"

OPEN FACE OR HUNTING

7 Jewels, Solid Nickel, with bright, flat screws, sunk second, plain hard enameled dial, spade hands, Breguet hair-spring. O. F. Pendant Setting



"The Diadem"

OPEN FACE OR HUNTING

15 Jewels in Raised Gold Setting, Solid Nickel Movement, upper and lower center bearing bushed with anti-friction metal, Breguet hair-spring, sunk second, glass enameled dial, spade hands, fine Damask, and finely finished throughout. O. F. Pendant Setting.



"The 400"

HUNTING ONLY

17 Jewels, in Raised Gold Setting, Solid Nickel, Breguet hair-spring, micrometer regulator, sunk second dial, finely Damasked and elegantly finished throughout.

They hold the most enviable position in the American watch trade of all Ladies' Watches. In quality, finish and timing, size and general beauty, they ARE IN A CLASS BY THEMSELVES

The Dueber-Hampden Watch Works

CANTON, OHIO



7801

THE MAN who doesn't advertise is a good deal like the fellow who throws his sweetheart a kiss in the dark — he knows what he is doing, but no one else does.

We know pretty well what we are doing — we shipped a half million last year — but when you know what we are doing as well as we do, we will ship a million.

We are therefore making our bow through the Jewelers' Circular-Weekly in an endeavor to put you next and let you in on the ground floor.

This is getting to be one of the best advertised and favorably known lines in the business. We intend to keep it up until there is not a jeweler in the country who does not know that the Fleur-de-Lis line is a winner.

THE MINERVA

This bids fair to be an interesting season in adjustable bracelets.



has never yet been equaled, and whatever is doing, you will find us there with the goods.



This trade-mark appears inside the cover of every box containing

MINERVA BRACELETS

Made by THE ELECTRIC CHAIN COMPANY Attleboro, Mass. Sold only by Fontneau & Cook Co. Sole Sales Agents

THE MINERVA GIRL

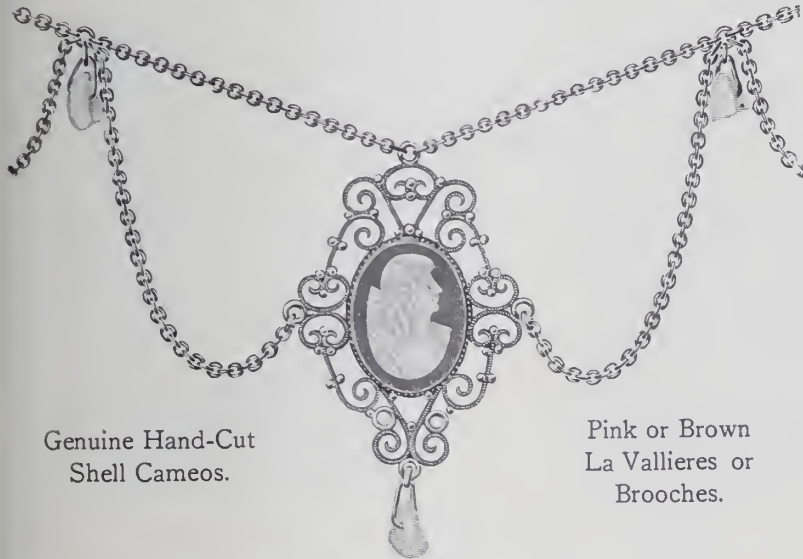

Genuine Hand-Cut Shell Cameos.

Pink or Brown La Vallieres or Brooches.

2699/265C

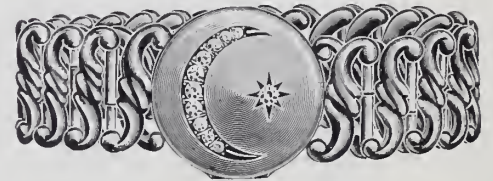

6170—Locket



8114—Polished Genuine Hand Cut Cameos. The Latest Fad.



7977 Polished 7978 Roman 7979 Old English 7980 Rose

We have every kind of an animal that is any good in the jewelry business.



8127—Polished 8128—Roman 8129—Old English 7/8 inch wide.

FONTNEAU & COOK CO.
ATTLEBORO, MASS.

CHICAGO
1203 Heyworth Bldg.

The KREMENTZ MATCH BOX

made expressly for paper matches, in 14-Kt. Gold and Sterling Silver, with the following finishes:
Roman, polished, engraved, engine turned and the Krementz gun metal finish.

Open

Side View
Closed



Order No.
in 14-Kt. Gold
2117



Order No.
in
Sterling
Silver
2043

Front View
Closed



PATENT APPLIED FOR

The side and front views show its compactness. It opens and closes easily and fits the vest pocket, taking very little space.

KREMENTZ & CO.

Manufacturers of

Fine Gold and Enamel Diamond Jewelry in 14-Kt. Only

MADE EXCLUSIVELY FOR FINE RETAIL JEWELRY TRADE

BRANCH

San Francisco Office
722 Shreve Bldg.

Factory and Main Office
NEWARK, N. J.

BRANCH

New York Office
1 Maiden Lane

WHITING MFG. COMPANY



“AUGSBURG” TEA AND COFFEE SERVICE

The greatest art sale of the 19th century was held at Christie's in London, in June, 1882, when the Hamilton Palace Treasures, collected by Alexander, the 10th Duke, sold for the sum of \$2,000,000.

Among these notable examples were a few choice pieces of antique silverware including the famous Augsburg Cup, for which Baron Rothschild paid over \$16,000; and next in importance was a silver-gilt Tea-kettle also of Augsburg (17th century) manufacture.

It is this Tea-kettle which served as the model for the Whiting Company's Tea and Coffee Service of which an illustration is here given.

BROADWAY AND NINETEENTH STREET

NEW YORK

San Francisco, Cal.,
717 Market St.

REMEMBER THE GUARANTEE IF FOR ANY REASON WITH THE ACCENT ON ANY

IF FOR ANY REASON THIS CHAIN Is Not Satisfactory To The Purchaser, It Can Be Returned To The Maker And A New Chain Will Be Given In Exchange
AUSTIN & STONE, INC. Attleboro, Mass.

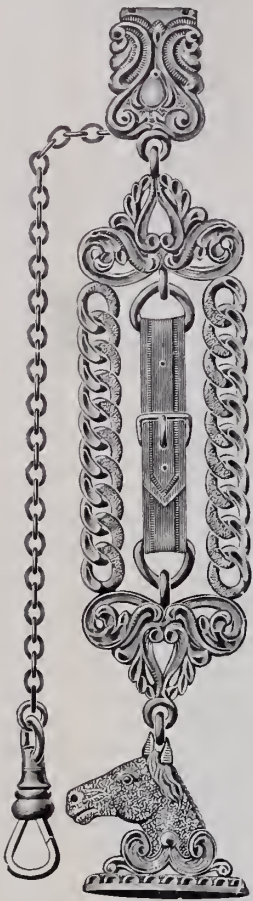

N104/54

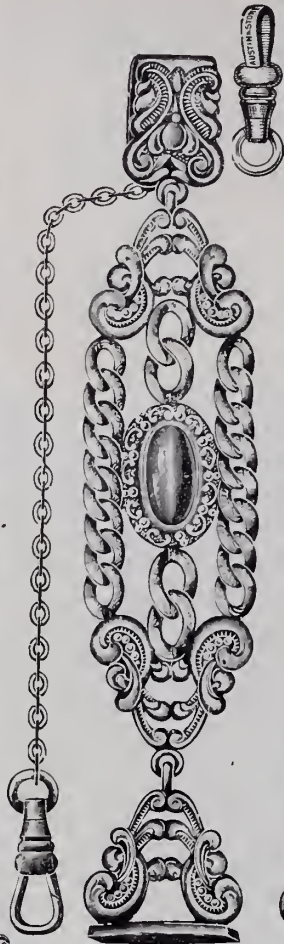

N113/62

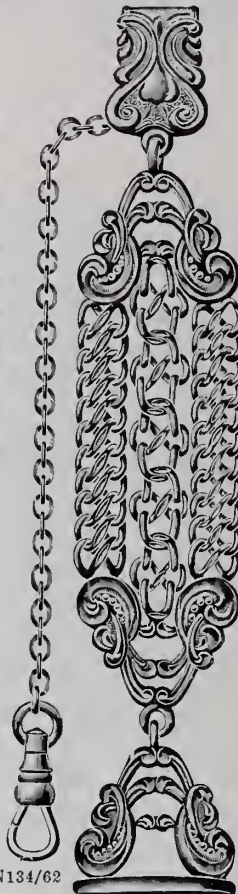

N134/62



N132/48

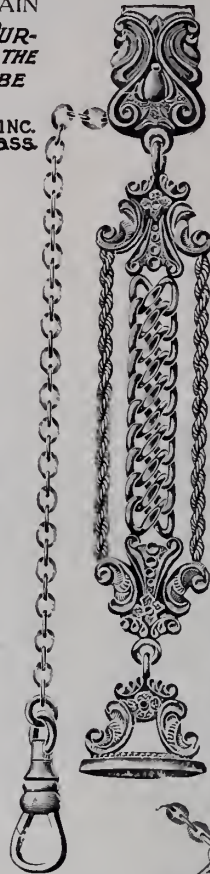

N129/38

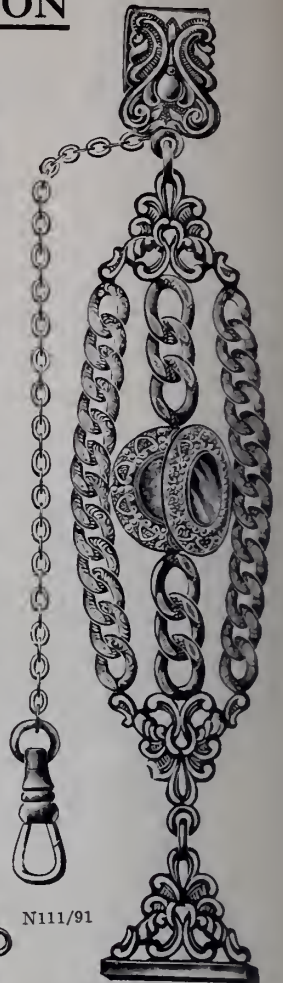

N111/91

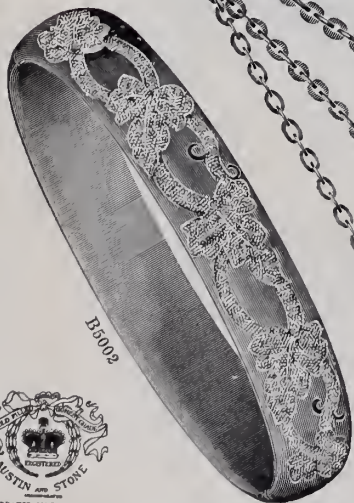

B5002



B5048

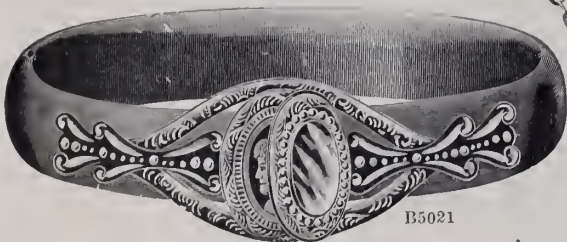

B5021



B5097



L12040



AUSTIN & STONE
Incorporated. ATTLEBORO, MASS.

SOLD TO JOBBING TRADE ONLY



WHY WAIT for bargain day? Community Silver is a bargain every day, since you get *more than triple plate*, and, therefore, *more than triple wear*, at about the price of ordinary plated ware.

Don't wait. Ask your dealer for Community Silver to-day, and furnish your table beautifully and economically.

More than triple plate

More than triple wear

An enlarged reproduction of a full-page Community Silver advertisement, which will appear during the months of March, April, May and June, 1908, in the leading magazines

Some of the striking and extremely effective Community Silver advertisements, which will appear during the spring months of 1908 in the Ladies' Home Journal, Woman's Home Companion, Minneapolis Housekeeper, Ladies' World, etc.

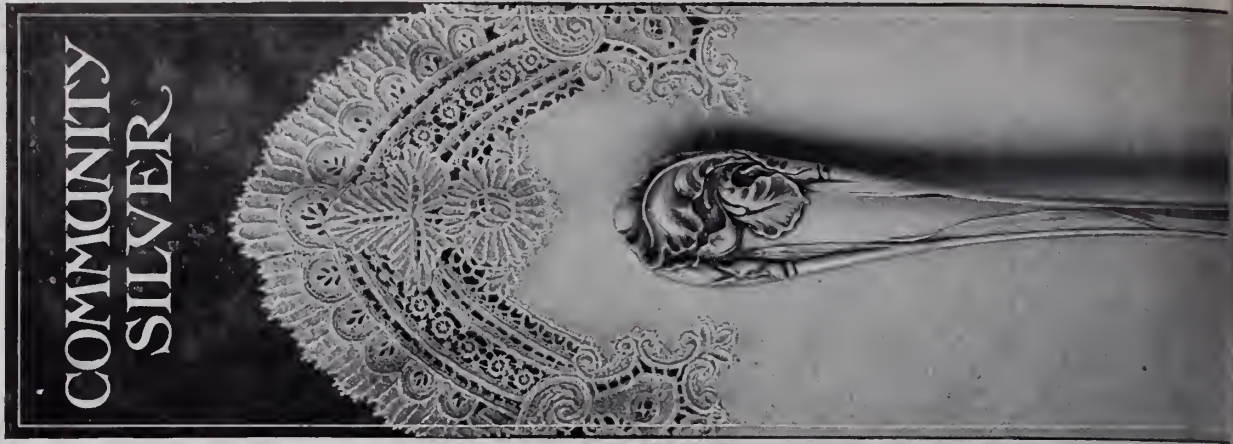
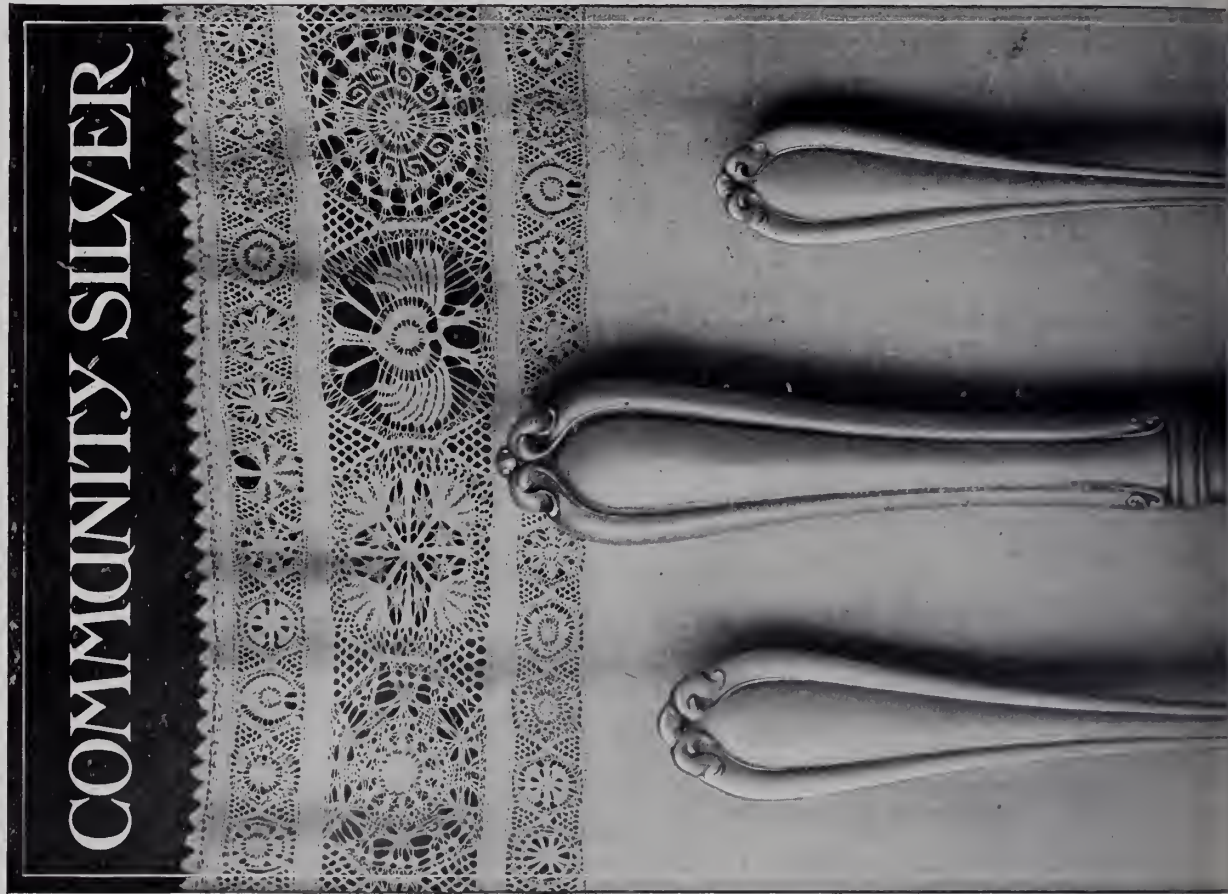

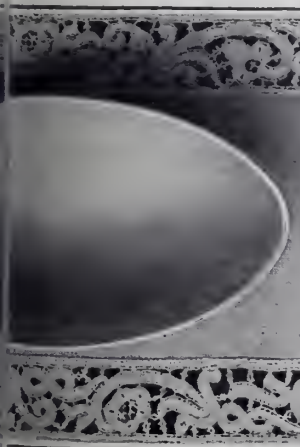

A MILLION WOMEN have shown their confidence in Community Silver by buying it.

Costing very little more than ordinary plated ware, it is so superior in quality and lasts so much longer that every woman can afford it.

Ask your dealer for Community Silver to-day. It will furnish your table beautifully and economically.

More than Triple-Plate
More than Triple Wear

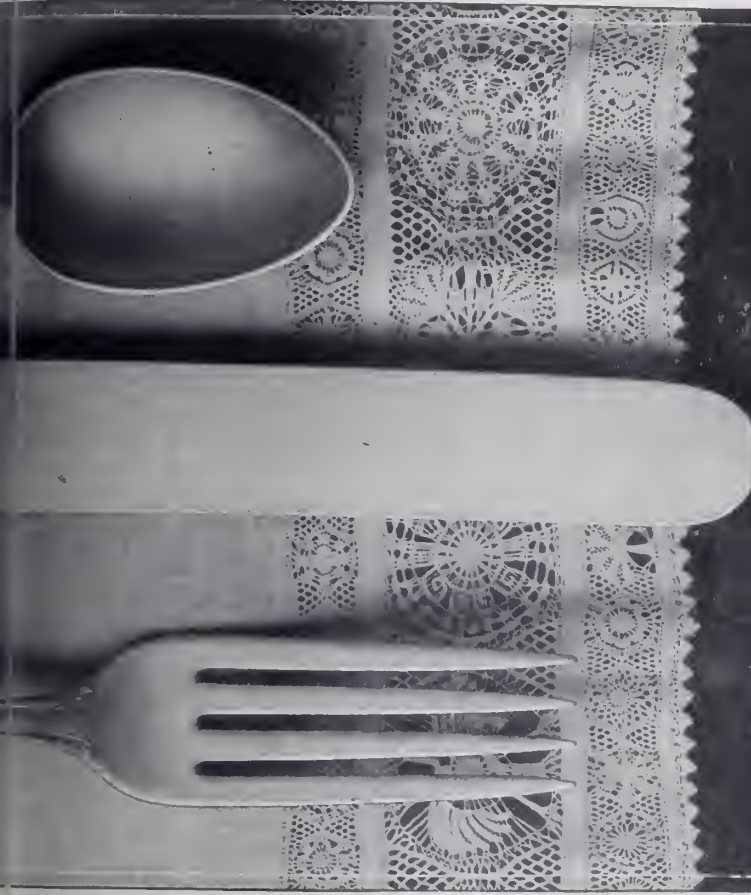

THERE is a delightful *social* satisfaction in possessing a perfectly appointed table.

Community Silver answers every requirement of the most exacting taste.

Its designs outrival Sterling in distinction, while its low price — about that of ordinary plated ware — brings it within the reach of all.

Ask your dealer for Community Silver to-day, and furnish your table beautifully and economically.

MORE THAN TRIPLE PLATE
MORE THAN TRIPLE WEAR



WHY WAIT for bargain day? Community Silver is a bargain every day, since you get more than triple plate, and, therefore, more than triple wear, at about the price of ordinary plated ware.

Don't wait. Ask your dealer for Community Silver to-day, and furnish your table beautifully and economically.

More than triple plate
More than triple wear

It is perhaps of interest to note that the beautiful backgrounds of these advertisements are reproductions from priceless linens at present in the possession of the Art Museum of New York City.

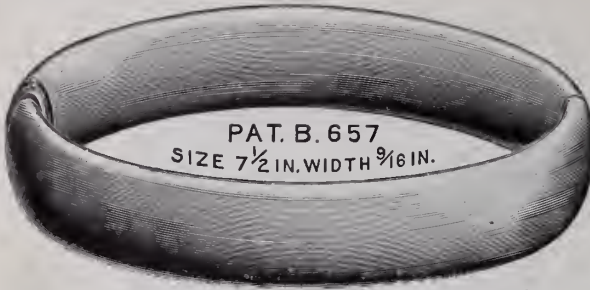

The consumer demands our Bracelets. Our new patterns will suit the most fastidious. Just the Bracelet for the Sweet Girl Graduate.



NEW YORK, 9 Maiden Lane
CHICAGO, 103 State Street

BATES & BACON

ATTLEBORO
MASSACHUSETTS

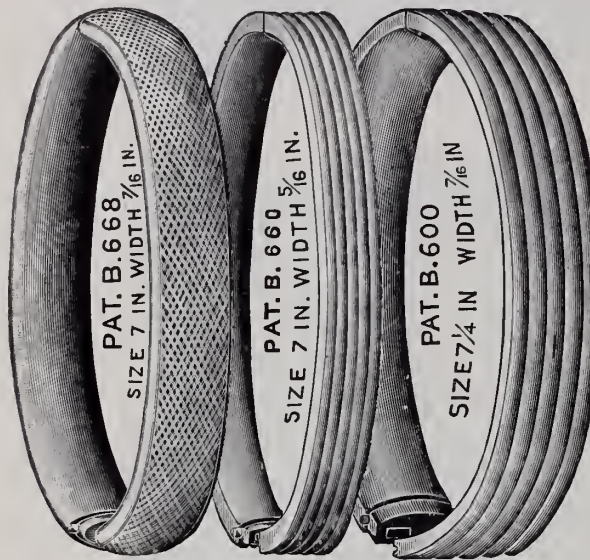

- GENTS' VESTS
- SAFETY FOBS
- DICKENS
- PONY
- NECKLACES
- LORGNETTES
- CHAINS
- BRACELETS
- LOCKETS
- CHATELAINES

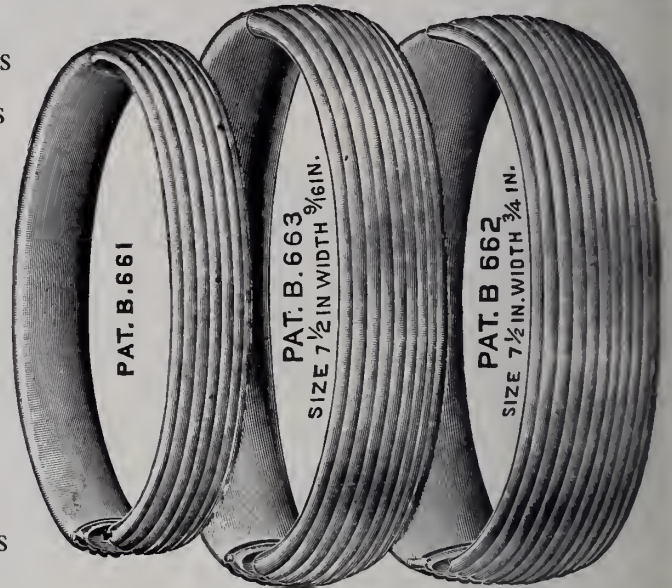

A NOVELTY FOR THE SMOKER

Sternau Ash-Receiver

No. 880

Height, $2\frac{5}{8}$ inches
Diameter, $4\frac{1}{8}$ "

Made in Silver-plate, Copper
or Old Brass

Has two shutters forming an upper bowl into which the refuse is thrown.

When the handle is turned the ashes or stub of cigar or cigarette fall to bottom of ash receiver, keeping the refuse always out of sight.

Furthermore, the lighted stub is soon extinguished, as the shutters, closed, act as a cover and smother the light, enabling one to do away with a cigarette or cigar, the odor of which may be offensive.

Prices and illustrations of other smokers' articles suitable for the Jewelry trade sent on request.

S. STERNAU & COMPANY

MAKERS OF

Coffee-machines, Fancy Teakettles, Chafing-dishes and their Accessories, Smoking Sets, Alcohol-stoves, Coffee and Tea Pots, Candlesticks, Trays, Baking-Dishes, etc.

New York Showrooms
BROADWAY, COR. PARK PLACE
Opposite Post Office

Office and Factory
195 PLYMOUTH STREET
BROOKLYN, N. Y.

High Art Reproduction of Jewelry

(Engraved and printed by our special color process)



Courtesy of Gibson Krugler Co
Newark N J

This is a sample page of our fine jewelry catalog which we are preparing for the Retail Jeweler
(Write us for particulars)

PENINSULAR ENGRAVING COMPANY
DETROIT, MICH

(See other side)



H. F. GRUSCHOW
Compiler of Jewelry Catalogs

¶ To the Retail Jeweler

¶ Are you interested in a beautiful Jewelry Catalog for this fall? We are preparing a sixty-four page catalog, which we are offering to the Jewelry Trade for their own distribution.

¶ We have carefully selected goods for this book from manufacturers who sell *direct to the Retail Trade*.

¶ You are not obligated to buy one cent's worth of goods in order to secure this beautiful catalog. You buy when you please, and then *direct from the manufacturers*.

¶ Do you realize, Mr. Jeweler, what an advantage this is? This catalog will be the finest and most attractive book ever offered to the Jewelry Trade.

¶ There are no strings attached to our proposition either. This is a clean, legitimate proposition, and it places you on the ground floor, where you can buy your goods *direct from the manufacturers*.

¶ This catalog will enable you to compete successfully with such mail order competition, as you well know, exists in your community to-day.

¶ We sell this catalog to only one dealer in a town. Write to-day for particulars.

Peninsular Engraving Company

Detroit, Michigan

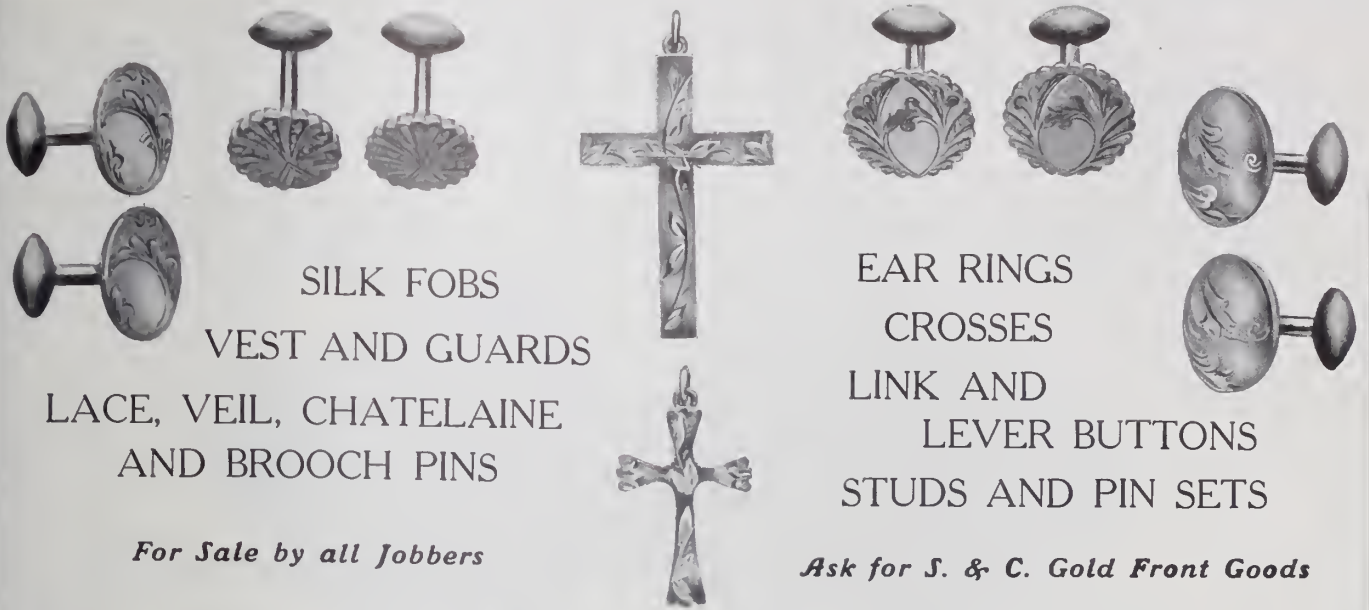

For Sale by all Jobbers

Ask for S. & C. Gold Front Goods

Smith & Crosby, Attleboro, Mass.

FACTORY:

Manufacturers of the Original Line of

SOLID GOLD FRONTS

The Finest Solid Gold Fronts made, all Hand Engraved.

All are Stamped S. & C. and Guaranteed

COMPLETE YOUR STOCK WITH RIGHT GOODS

GOLD RINGS

Gold Scarf Pins

Gold Brooches

A Handsome Line of Seamless Wire GOLD FILLED RINGS

All ready for prompt delivery to the Jobber

OSTBY & BARTON CO.
PROVIDENCE, RHODE ISLAND

New York Office
9-13 MAIDEN LANE

Chicago Office
103 STATE STREET

E. A. POTTER COMPANY

Providence

Rhode Island

ORIGINATORS OF

THE "HOLDWELL" COLLAR AND BOW PIN



NUMEROUS IMITATIONS PROVE ITS MERITS

We make Fifty Designs, all in High Grade Gold Filled. Buy of the Originators and get Quality, Design and Finish. Hereafter Holdwell pins will be stamped "Holdwell" on back.

Representatives
 LOUIS S. HODGES
 HARRY E. FARQUHARSON

SEE OUR NEW GOODS IN
 CUFF PINS, VEIL PINS, ETC.
 READY MAY 1st.



The Original **Carmen Adjustable Bracelet**

With 20 years' experience and the best factory equipment that can be procured, we are able to produce

THE BEST IN THE WORLD FOR THE MONEY

The stamp, "The D. F. B. Co.," is a guarantee of quality and up-to-date designs. Ladies' and Gentlemen's Chains, Fobs, Lorgnettes, La Vallieres, Hat Pins, Chatelaine Pins and Bracelets.

THE D. F. BRIGGS COMPANY

ATTLEBORO, MASS.

NEW YORK OFFICE
 180 Broadway

CHICAGO OFFICE
 Heyworth Bldg.

ST. LOUIS OFFICE
 Mermod & Jaccard Bldg.

LONDON OFFICE
 118-122 Holborn E. C.

Snake Bracelets and Necklaces

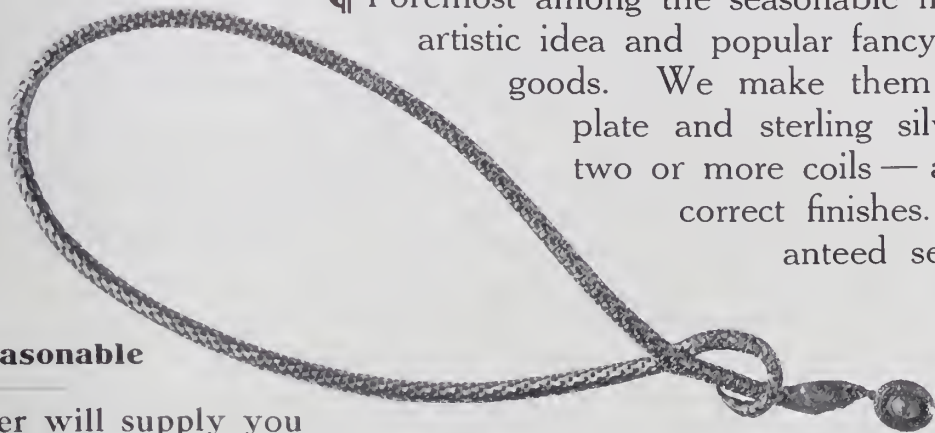

Foremost among the seasonable novelties in artistic idea and popular fancy are these goods. We make them in rolled plate and sterling silver — one, two or more coils — any of the correct finishes. A guaranteed seller.

**Prices
Very Reasonable**

Your Jobber will supply you



Made by **WHITING & DAVIS**

NEW YORK OFFICE
7 Maiden Lane

Plainville, Norfolk Co., Mass.

ENGELSMAN'S PATENTED COMBINATION "GEM" DISPLAY RINGS and ADJUSTABLE STONE HOLDERS MEET A LONG-FELT WANT

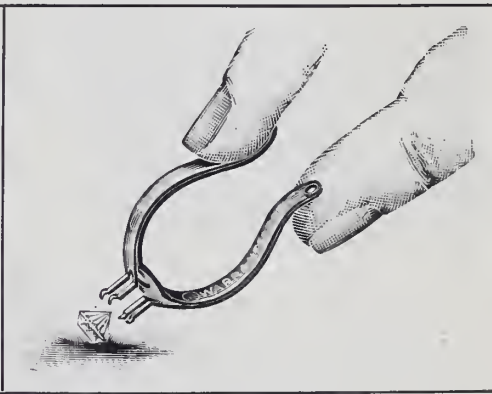
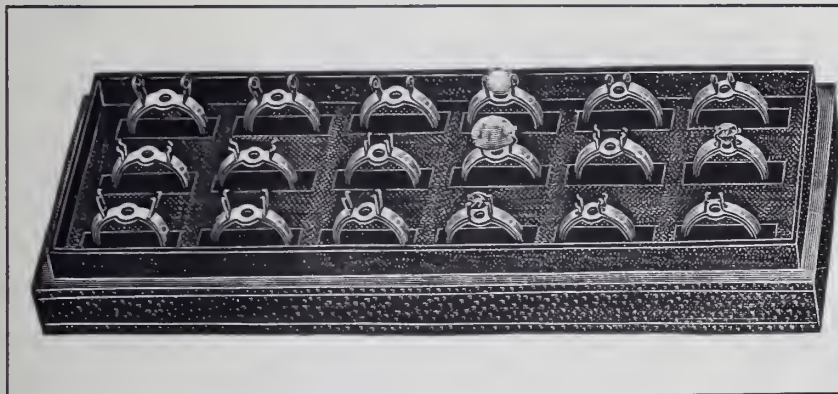

THEY ARE MONEY-MAKERS AND MONEY-SAVERS

UNMOUNTED STONES of any size and shape can be displayed advantageously, as is herein illustrated. Your investment in stock can thereby be *decreased*, as you need not mount them up in expensive settings. Your sales will also *increase* by being able to exhibit unmounted stones. The prices are *low* enough to induce you to buy them and *save* you from incurring frequent losses caused by the awkward handling of the tweezer when your customer desires to examine unmounted stones. Try them. For sale by all jobbers.

Due to greatly improved automatic machinery and reduced cost of production, we are now quoting these as follows:

Sets of 18 (full set), in box,	\$6.00
" " 12	4.00
" " 9	3.00

HAMMEL, RIGLANDER & CO.

47 Maiden Lane, New York

Selling Agents for United States and Canada



AT all times and under all conditions there is some demand for watches, and the present season is not an exception. Filled watches have been better "Sellers" than usual and we have an attractive assortment of same, besides all grades of movements, and can attend to your wants promptly and efficiently.

Our medium priced line of gold jewelry is exactly suitable for the requirements of the Spring trade, and our "Sellers" will help to swell your sales.

"Sellers of Sellers"

HENRY FREUND & BRO.

71 Nassau St., NEW YORK

Watches
Diamonds
Jewelry

ELK AND F. O. EAGLE
GOODS A SPECIALTY

Our Trade-Mark  "The Rose," stands for quality and excellence

SOLD DIRECT TO THE RETAIL TRADE ONLY

FEATURES OF OUR LINE

The UNIQUE, ARTISTIC and UNUSUAL, together with BEST WORKMANSHIP, SUPERIOR QUALITY and PERFECTION IN FINISH



296

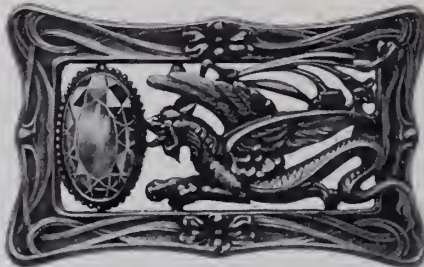

624

SASH BROOCHES
in gold-filled, finished in rose or dark green (antique).

Sash Brooches

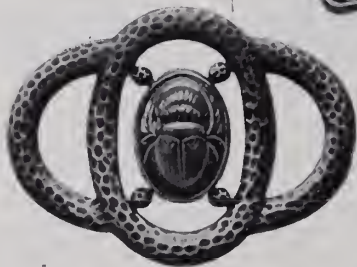

237



316

We use finest imitation stones and can furnish any stone or color required.

We Manufacture in GOLD-FILLED and STERLING SILVER

BROOCHES, HAT PINS, COMBS, HANDY PINS, WAIST PIN SETS, BARRETTES, SCARF PINS, VEIL PINS, LINKS, BUCKLES, SASH BROOCHES, BRACELETS and NECKLACES.

C. RAY RANDALL & CO., North Attleboro, Mass.

NEW YORK OFFICE, No. 7 Maiden Lane

SAN FRANCISCO OFFICE, Henry M. Abrams Co., No. 717 Market Street

Address all orders and communications to Factory, North Attleboro, Mass.



Coasters

One of our many designs, new this Season, made in all sizes, from 3 inches to 6 inches.

3 inch

No. 444
(Actual size)

\$10.50 dozen

Prices \$10.50 to \$27.00
per dozen

Frank M. Whiting & Co.

SILVERSMITHS

320 Fifth Avenue, New York

North Attleboro, Mass.



"Kotobuki"



(Pronounced Ko-to-bū-ki)

THE JAPANESE WORD FOR LONG LIFE

The Popular Craze in

SCARF PINS

Price in 14 Kt.
\$3.00

MANUFACTURED IN 14 KT. GOLD BY

Price in 14 Kt.
\$3.00

VAN DUSEN & STOKES CO.

MAKERS OF ORIENTAL JEWELRY

IMPORTERS OF CORAL AND SEMI-PRECIOUS STONES

1123 CHESTNUT STREET

- - - - -

PHILADELPHIA

The Best Selling "Thread" Pattern in the Trade



The SMITH "PILGRIM"

There never has been a more artistic and lasting design than the Smith "Pilgrim." It is characterized by simple elegance, refinement and dignity of design, and grateful absence of over-ornamentation. The Smith "Pilgrim" pattern will remain permanently in demand. Include "Pilgrim" in your stock. It is without question the best selling "thread" pattern in the trade to-day. Made in all the fancy pieces.

FRANK W. SMITH CO. MANUFACTURERS OF STERLING SILVERWARE Gardner, Mass.



66112

Mr. Retailer :

This cut shows the ACTUAL SIZE of a 14K. Gold Watch Case (weighing 285 $\frac{1}{8}$ dwts.) made by us SIXTEEN YEARS AGO for Messrs. C. G. ALFORD & CO., NEW YORK.

Notwithstanding its size, it really was a work of art,

AND

That case was stamped :

"SOLIDARITY"

Solidarity Watch Case Co.

Established 1885

54 Maiden Lane, New York

General Selling Agents

JOHN W. SHERWOOD FRANK E. HARMER

A "Complete" Line

and when we say "complete" we mean it in its strictest sense—full, perfect, leaving nothing to be desired. Not only in one grade of Sterling, but in several, from the cheapest to the most exclusive—without question the largest and most varied assortment to be found anywhere. Every size and every style—all handsome, and all possessing a certain distinction that adds greatly to their selling value.



No. 2486.

Card Cases furnished in plain, hand engraved, etched and ornamental die work. Also fitted up with clasp purses. Satchel Shaped Purses with silk lining. Several sizes of Vanity Boxes with compartments for all the necessary vanity articles. Vanity Boxes with very fine leather linings, containing Puff, Mirror, Tablet, Pencil and Change Compartment, in various sizes. In fact, the variety and extent of this line can only be suggested in this space. See the entire line. There must be many pieces that will appeal to your customers.

R. BLACKINTON & CO.

ESTABLISHED 1861. SILVERSMITHS

Factory, North Attleboro, Mass.

3 MAIDEN LANE, NEW YORK

TRADE  MARK

A Good Line All Through

The Simmons line of Vest, Lorgnette, Neck and Eye Glass Chains, Fobs and Bracelets, is good all through. Every article represents the fullest value for its price that can be had.

Compared with any other goods the market offers—for good styles, tasteful designs, thorough workmanship and excellence of finish—you will find that the Simmons line offers advantages that are bound to appeal to your customers and that render it the readiest selling line of gold-filled goods you can handle.

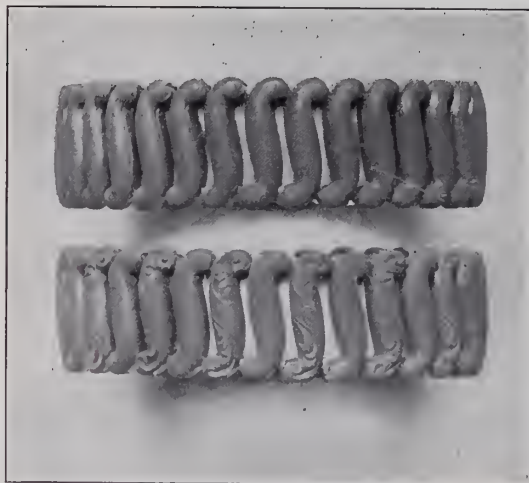

An inspection of the SIMMONS ADJUSTABLE BRACELET will satisfy you that it is the best article of its kind that has yet been shown.

It is just what many jewelers have been looking for—a high-grade extension bracelet of neat and graceful design, simply, but substantially made, a bracelet that can be confidently shown to one's "best trade."

Made of 1-10, 12 K. gold-filled stock, in plain polished and alternating plain and chased links.

A sample dozen will prove to your satisfaction that the best proposition in adjustable bracelets is the SIMMONS. Order from your jobber.

R. F. SIMMONS COMPANY

Main Office and Works: Attleboro, Mass.

NEW YORK SALESROOMS:
9-13 MAIDEN LANE

CHICAGO SALESROOMS:
42 MADISON ST. (HEYWORTH BLDG.)

Holmes & Edwards

MAKERS OF

SILVER INLAID SPOONS

THE Lafayette DESIGN



BERRY SPOON.



COLD MEAT FORK.

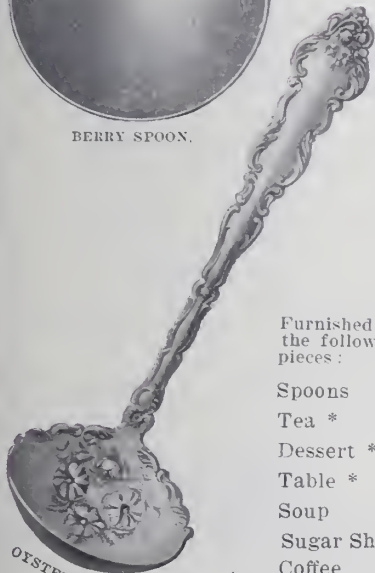

OYSTER LADLE



Plated Silver
with pieces of
Sterling Silver
Inlaid
at the points
where it rests on
the table

"Solid Silver
Where it Wears"

Discovery
It was found after
the heavy plate
had been removed
that pieces of
solid silver had
been inlaid at the
back of the Bowl
and Handle.

Fact
They have out-
worn our 25
year guarantee.



Trade Mark on every piece.

Send for the little
book

**HOLMES
& EDWARDS
SILVER CO.,**
BRIDGEPORT, CONN.
(International Silver Co.,
Successor.)

LAFAYETTE
TEASPOON
(Patented)



MEDIUM FORK AND HH
MEDIUM KNIFE.



HOLMES & EDWARDS

Furnished in
the following
pieces :

Spoons

- Tea *
- Dessert *
- Table *
- Soup
- Sugar Shell *
- Coffee
- Childs
- Berry
- Salad

Forks

- Dessert *
- Medium *
- Childs
- Oyster
- Pickle
- Ice Cream
- Cold Meat
- Salad Individual
- Salad Serving
- Fish Serving

Knives

- Dessert HH.
- Medium HH.
- Breakfast HH.
- Butter *
- Butter Ind.
- Fish Serving
- Sugar Tong
- Food Pusher

Ladles

- Cream
- Gravy
- Oyster
- Soup
- Punch

*Made in Sterling Silver inlaid.

The Holmes & Edwards Silver Co.

International Silver Co.
Successor

BRIDGEPORT, CONNECTICUT

POINT OF VIEW IN COLLAR BUTTONS



THE MAN who wears it is the one the Collar Button means most to. What is said about it is not so important as how it wears, whether it is comfortable, smooth, shapely and strong. Durand Collar Buttons have these virtues. No mechanism; no bother. They keep the friends they make.



PRICES: \$1.15 to \$4.00

DURAND & CO.

49-51 FRANKLIN STREET
NEWARK, N. J.

A Season of Staples

THIS is a season of staples. There will be buying, of course, but it will be along established lines. It is in such lines that this house takes a foremost place.

For example:

BEAD
NECKLACES

SASH
BUCKLE PINS

BELT BUCKLES

VEIL AND HANDY
PINS

BARRETTES

HAT PINS

COMBS

SCARF PINS

LINK BUTTONS



Day, Clark & Co.

14-k. Gold Jewelry

23 Maiden Lane
NEW YORK



OSMUN-PARKER MFG. CO.

MAKERS OF

Fine Pearl and Diamond Goods

338 Mulberry Street
NEWARK, N. J.

"THE BRACELET HOUSE"

GOLD BRACELETS of every kind
For WOMAN, MISS OR BABY

KENT & WOODLAND

16 John Street, New York

Factory: Newark, N. J. San Francisco: Julius A. Young



SEED-PEARL NECKLACES IN ALL SIZES.

OSMERS-DOUGHERTY CO.

MANUFACTURING JEWELERS

291-293 SEVENTH AVE., NEW YORK

Bet. 26th and 27th Sts. Telephone, 913 Madison.

DEALERS IN
BAROQUES, PEARLS and
FANCY STONES



DESIGNING
AND
SPECIAL ORDER WORK

G. R. HOWE
W. T. CARTER
W. T. GOUGH

ESTABLISHED 1841 BY A. CARTER

F. R. HORTON
F. W. STANBROUGH
H. L. FARROW

CARTER, HOWE & CO.

MANUFACTURERS OF

GOLD JEWELRY



ARTISTIC—SALABLE—RELIABLE

Most Comprehensive Line Offered

9-11-13 Maiden Lane, New York

Factory, Newark, New Jersey

SOLID GOLD BUCKLES AND SASH PINS

PLAIN AND ENGRAVED

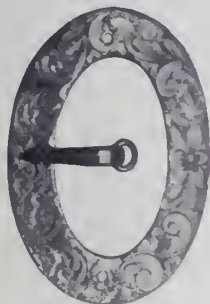

14 K.—Everything in Gold Jewelry—10 K.

Brooches, Links, Bracelets, Scarfs,
Fobs, Lockets, Hat Pins, Festoons,
Emblems, Gold Novelties, Pend-
ants, Earrings, Combs, etc.

Chas. L. Trout & Co.
MANUFACTURERS

2 Maiden Lane, New York

UNIQUE GEMS

I am showing an entirely new lot of NATIVE, CEYLON,
URAL and BRAZIL semi-precious stones, in new and
fancy cuttings as well as cabochons. ALL GENUINE.
Sample papers sent to reliable dealers.

Louis J. Deacon, CAPE MAY N. J.
(Summer headquarters)

I. N. LEVINSON, President

ESTABLISHED 1865

H. S. MORRIS, Sec. and Treas.

S. COTTLE COMPANY

Makers of High-Grade Gold, Silver, Gun Metal Novelties

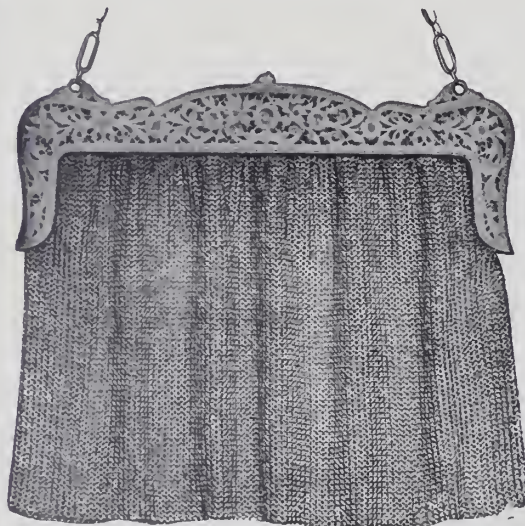

- Mesh Bags
- Buckles
- Card Cases
- Chatelaines
- Vanity Cases
- Sash Pins
- Purses
- Hat Pins

S. COTTLE CO.

31 EAST 17th STREET
NEW YORK

PARIS, 28 Rue D'Hauteville

HILL & SCHMIDT

71 Nassau Street

NEW YORK

Makers of Artistic 14 kt. Jewelry

SPECIAL DESIGNS IN

LA VALLIERES, HANDY PINS also
New Style Ear Drops

COMMENCEMENT TIME IS HERE

and every Jeweler will need Snappy and Inexpensive stock to suit the occasion.

Let us send you a Selection Package of our very appropriate jewelry.

We have many novelties and exclusive things which will surely increase your Midsummer Business. We make only high-class 10-K. Jewelry.

The Keller Jewelry Mfg. Co.

64 Nassau St., New York

Factory: Newark, N. J.

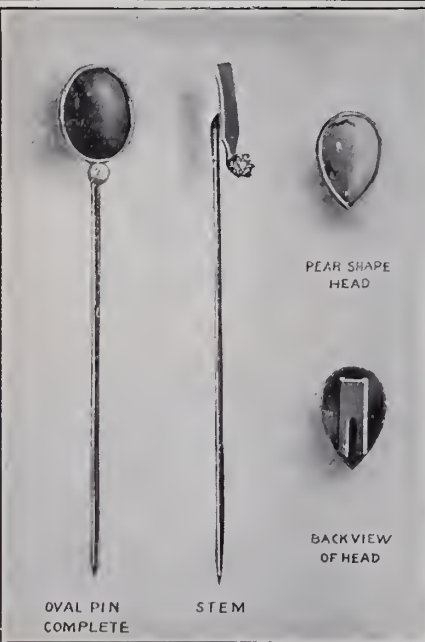

Interchangeable Scarf Pin

PATENT PENDING

The smart dresser wears a pin to harmonize with his cravat. Our new device permits the wearer to use a diamond or pearl in combination with any colored stone, such as Lapis Lazuli, Moonstone, Turquoise Matrix, Jade, Topaz, Amethyst, Garnet, etc., by merely snapping the colored stone on the pin, as shown in illustration. Easy to attach or detach—nothing to break. Made in 14 Kt. only.

ROTHSCHILD BROS. & CO.



The Locket House 51-53 Maiden Lane, New York

THE BEST SOLID GOLD CHAINS

THE CHEAPEST

They stand the test of time and have done so for 56 years.

Supreme in
QUALITY
DESIGN
FINISH
WORKMANSHIP



We Sell Direct. We Have No Salesmen. Eliminating all unnecessary expenses in making and selling enables us to sell at the lowest possible price. Send for catalogue.

Trade  Mark

1850 1907

ALOIS KOHN & CO.

16-18 Maiden Lane, New York

Makers of **Gold Chains** of every kind



F. DE SIMONE & SON
Importers of Coral

76 Nassau Street, New York

FACTORY
TORRE DEL GRECO
ITALY

LEO CAHN
General Representative

TRADE  **SNOW & WESTCOTT CO.**

21 MAIDEN LANE, NEW YORK

MARK. JAMES P. SNOW

CHAS. E. WESTCOTT

Makers of Fine Gold
Jewelry

ESTABLISHED 1834



The R. S. Cigar Cutter

In Sterling Silver, Plain and Engraved; and 14 k. Gold, Plain and Engraved, also Set with Diamonds.

A Novelty

Unlike all other cigar cutters, this one lies flat in the pocket—does not get out of order.

A Good Article



We Push It

Our advertising makes the customer want it; his friend sees it and he wants it. An endless chain of customers.

A Good Seller



Trade supplied by

Enos Richardson & Co.

23 Maiden Lane, New York.

NEW DESIGNS IN HANDY PINS



Made in all colors
and finishes



Greatest variety of
designs and
sizes



TRADE-MARK

A. J. HEDGES & CO.

Makers of Exclusive Designs
in High Grade 14K. Jewelry

14 JOHN STREET, NEW YORK

ENOS RICHARDSON & CO.

23 Maiden Lane



Trade-Mark

New York, N. Y.

MANUFACTURERS OF 14 K. GOLD JEWELRY

Handy Pins

Dumb-Bell Links

Hat Pins

Safety Pins

Fobs

Scarf Pins

Brooches

Tie Clasps

Barrettes

Flat Links

Veil Pins

Belt Pins

10 K. and 14 K. Neck Chains
and Guard Chains

Plain and Jeweled Lorgnette Chains



After May First

Our New York Office
will be in the

Silversmiths Building

15-17-19 Maiden Lane - Rooms 1706 and 1707

S. K. Merrill Company

LOCKET MAKERS

FACTORY

116 Chestnut St., PROVIDENCE, R. I.



Fancy Platforms and Blocks for
Window Display.

Trays, for Show Cases and Trav-
elers' Use, of every description.

Jewelry Boxes in many qualities
and styles.

Boxes for silverware. Manicure
and Toilet Sets.

Silverware Chests in any combi-
nation.

Flannel Rolls and Bags for Silver-
ware.

We Re-cover Window Platforms
and Trays.

PAPER BOXES.

Tags, Cards, Cotton, Findings, Etc.
Estimates and Samples Cheerfully Furnished.

WOLFSHEIM & SACHS

Office and Salesroom:

35 Maiden Lane,
(Lorsch Building)

NEW YORK

Factory: 10 Gold Street, N. Y.

EVERYTHING IN LOCKETS AND CHAINS.

THE BASSETT JEWELRY CO.,

PROVIDENCE, R. I.

TRADE



MARK

Geo. O. Street & Sons

35 Maiden Lane, New York

Established 1837

RINGS

SLEEVE-LINKS

SCARF-PINS

FOBS AND SEALS

LOUIS G. SCHLEHR MANUFACTURING JEWELER

178-180 Ellicott St., Buffalo, N. Y.

All Out-of-town Work returned within 3 days from date received

Rings, Diamond Mountings,
Diamonds and Precious Stones,
Badges, Class Pins

General Repairing Artistic Engraving



No. 58

THE
ARCHIBALD-KLEMENT
LINE OF

SILVER DEPOSIT WHISKY BOTTLES

Distinguishable for their
dignity of design and ex-
cellence of finish. Made
in full quart size, four de-
signs—Narrow Strap,
Broad Strap, Rye, Thistle.
Shield space for mono-
gram, sterling silver cork-
screw tops. Highball
and whisky glasses to
match each design.

Full line of the foregoing, and any other desired
pieces in the A-K Silver Deposit Ware, sent on
approval.

ARCHIBALD - KLEMENT CO.

Sample Rooms: 341-347 Fifth Ave., N. Y.

Factory: NEWARK, N. J.

Fans

Designed by artists, made by experts, our line represents harmonious beauty and excellent quality. We show a large variety in all prices for Graduation, Confirmation, Weddings, etc.

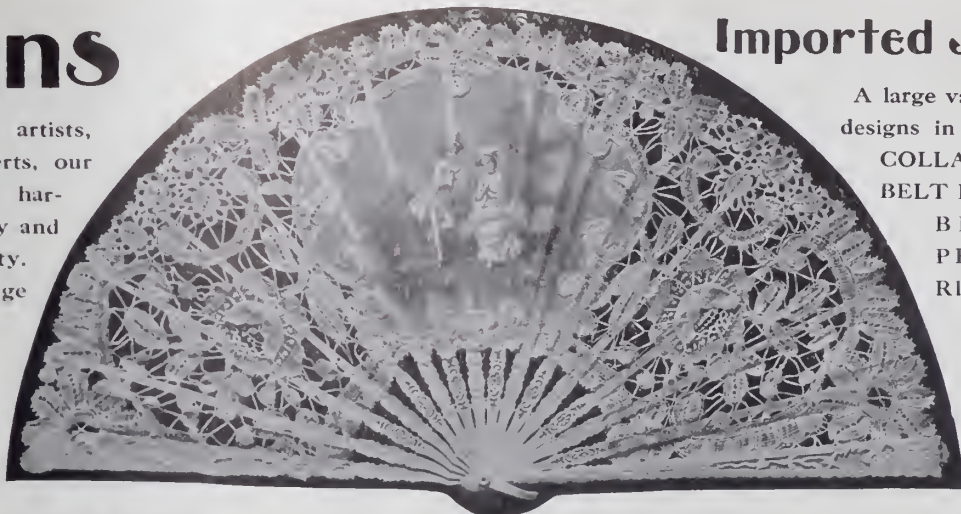

Imported Jewelry

A large variety of choice designs in NECKLACES, COLLARS, BUCKLES, BELT PINS, CHAINS, BROOCHES, PEARL EAR-RINGS, Etc., Etc.

Send for Selection mentioning price.

LEWY & COHEN, 530 Broadway, cor. Spring St., N. Y.

The Allsopp Rings

The Up-to-Date Line of **Signet and Set Rings**



In twenty years we have built up a business second to none in RINGS EXCLUSIVELY



Allsopp QUALITY, DESIGN AND WORKMANSHIP Appeal to the Most Fastidious. It Will Pay You to Examine a Selection Package.

A ★ TRADE-MARK.

Allsopp Bros. Allsopp Building, Newark, N. J.

The Bowden Rings

ARE COMPLETE IN VARIETY, CORRECT IN QUALITY AND PERFECT IN FINISH. WE MAKE EVERY VARIETY OF FINGER RINGS.

J. B. BOWDEN & CO.,

1 Maiden Lane,

NEW YORK.

THE CROWN PATENT SAFETY GUARD



For Scarf Pins, Pins. The most adjustable one invented. Price, \$1.50 per doz. For sale by all wholesale jewelers and material houses. Sample by mail, 25c.; in 10k. gold, \$1.00; 14k., \$1.25. M. CROWN Maker and Inventor, 48 and 50 Maiden Lane, N. Y.



Try Wells' Perfect Ring Adjusters

1 doz. asst. sizes 10k gold filled (gold on front twice as thick as on back), \$2.00. 1 doz. asst. sizes solid 10k gold, \$3.75. 1 doz. asst. sizes, metal, 85c. Ask your jobber for them, or I will send, prepaid, at once (only on receipt of price), two samples—one small and one medium large gold filled and one metal adjuster for 50c. Address

CHESTER H. WELLS, Jeweler, Meshoppen, Pa.

DIAMOND MOUNTINGS

of any description in gold and platina

Order Work a Specialty

HENRY BASCHKOPF

47-49 Maiden Lane

New York, N. Y.

LOCKETS ONLY

Registered



U. S. Pat. Office



NUMBER
8489

Old English Style and Finish; Hand Decorated

WIGHTMAN & HOUGH CO.

NEW YORK OFFICE
3 Malden Lane

Main Office and Factory } 7 Beverly St.
PROVIDENCE, R. I.

BROOCHES

Just now cameo and single stone Brooches are holding the center of the stage, and every Jobber should have at least a few numbers in his lines this spring. The business conditions make it necessary for you to keep abreast of the times. Let us send you a few samples on memorandum.

R THIS TRADE-MARK on every piece of jewelry that leaves our factory. A medium-priced line of 10K. jewelry that has stood the test. Will say no more, but let us show you and be convinced yourself.

Send for further information regarding our extensive line.



1109



1110 Amazonite

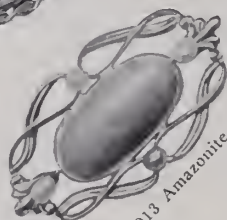

1013 Amazonite

W. E. RICHARDS CO.

Manufacturers for the Jobbing Trade
ATTLEBORO, MASS.

New York Office: 12-14 John Street Samples only

WM. SMITH & CO.

OFFICE: Established 1854.

MANUFACTORY:

9-13 Maiden Lane, New York

61 Peck St., Providence, R. I.

Manufacturers of GOLD AND SILVER CHAINS
GOLD, SILVER AND PLATED CHAIN TRIMMINGS

Also GOLD AND SILVER
KEY CHAINS AND
BRACELETS

S. F. Myers & Co

WHOLESALE JEWELERS

47-49 Malden Lane

New York

To do better to-day the thing done well yesterday; to serve better to-morrow than ever is our constant effort.

For the trade only — our new, big catalogue, with 100,000 items, sent free.

THE WASHBURN

SECURITY **MAGIC NUT**
Automatic Holder for ear studs, scarf-pins etc.
for all sizes of scarf-pin wire. Guaranteed.



EAR WIRES
for unpierced ears.



Open.



Closed.



Open.



Closed

SAFETY CATCH
For Brooches, etc.
Can be applied to any work where pin tongue are used.

Descriptive Circular on Application.

Pearl Drilling and Adjusting a specialty.

Special Order Work and Repairing.

C. IRVING WASHBURN, 12-16 Jona St., N. Y



LA VIGNE TEASPOON



LA VIGNE TABLESPOON



LA VIGNE MED. FORK

The latest and newest in ROGERS FLATWARE

HAVE YOU SEEN IT?

Bright or French Gray. Sample dozen on approval. Write for prices and terms.

JOSEPH IRONS, 35 Maiden Lane



After May First

Our New York Office
will be

Rooms 1706 and 1707

Silversmiths' Building

15-17-19 Maiden Lane

Telephone Connection

**E. L. SPENCER
COMPANY**

Makers of
Solid Gold Jewelry

Factory:
95 Chestnut St., Providence, R. I.

CUFF BUTTONS
 ** IN EVERY POSSIBLE VARIETY **
 WE ARE THE LARGEST EXCLUSIVE MAKERS OF 10-K JEWELRY
 ASK YOUR JOBBER FOR P. & B. LINES OF
 Cuff Buttons, Crosses, Beadnecks, Tie Clasps,
 Brooches, Baby Pins, Scarf Pins, Bracelets,
 Locketts, Fobs.

NEW YORK
OFFICE
65 NASSAU ST.

POTTER & BUFFINTON CO.
PROVIDENCE, R. I.

**Sterling
Silver
Horseshoes**

14 Karat
Gold Finish
set with
Whitestones
or Pearls

Write for Selection
Package with
Prices

Wachenheimer Bros. 36 GARNET STREET
PROVIDENCE, R. I.

CHARLES M. PRIOR, Designer

Designs for Gold and Silversmiths.
I have added Ornamental Engraving to my Etching Department.

24-26 East 21st St., NEW YORK
Phone 1639 Gramercy

MERIT TELLS

VERIBEST LOCKETS

It is Merit that has gained for the  Locketts since 1870 FIRST HONORS AND AWARDS wherever exhibited.

The creations of the S. & B. L. Co. Locketts labeled with trade-mark are now so widely known that they are to be seen in every city in the world.

MERIT SELLS

S. & B. LEDERER CO.

“QUALITY WEARS GOODASGOLD”

New York City: 9-11-13 Maiden Lane Providence, R. I.: 100 Stewart St. Chicago, Ill.: 131 Wabash Ave



Something new and unique in Ladies' MONOGRAM BELT BUCKLES with back slides to match. Made in 14Kt. GOLD, STERLING SILVER and GOLD PLATE. JUST THE THING FOR SUMMER.

WALDRON & CARROLL, 34 Warren St., New York City

Perennially Popular

THE best evidence of the popularity of our various lines is the increasing demand for them and our consequent growth. Our jewelry is unexcelled in every quality that contributes to serviceability and appearance. The designs are artistic enough to court that investigation which results in sales.



Ask to see our line of

CHAINS
CHAIN PENDANTS
CROSSES
AND BRACELETS

The
Kenilworth
Bracelet

particularly, the strongest on the market.

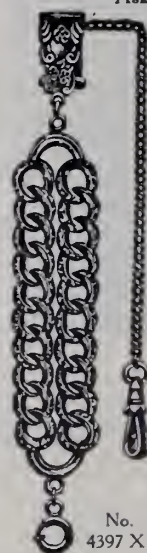

DORAN,
BAGNALL & CO.

North Attleboro, Mass.

OFFICES

New York: 194 Broadway.
Chicago: 42 E. Madison St.
San Francisco: 91 Drumm St.

No. 4397 X1



No. 3325C.

BROOCHES

New Goods.
New Styles.

All the popular stones: Lapis Lazuli, Amazonite, Amethyst, Topaz, Jade, Garnet, Turquoise Matrix, etc.

Trade Mark.

The EDWIN LOWE & CO., Inc.

F. W. BODWELL, Pres. & Gen. Mgr.
116 Chestnut St., PROVIDENCE, R. I.
New York Representative: Western Representative:
E. T. Wilson, 180 B'way. S. H. Brower.

GARREAU & GRISER
68 & 70 Nassau St., New York
LAPIDARIES. PRECIOUS STONES
GEMS in Unique Cuttings

Trade-Mark.

Trade-Mark.

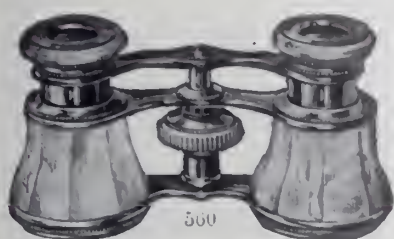

COLMONT OPERA and FIELD GLASSES

have been recognized by Opticians who really wanted a good article without paying too high a price.

With Colmont Glasses
You Have a Guarantee

The name STANDS for honesty and uniformity of construction, fairness of price.

For your own advantage, investigate the "COLMONT" line at your jobber's.

**SUSSFELD, LORSCH
& CO.**
Importers

NEW YORK

PARIS



Athletic Medals Trophies Awards for Scholarships, etc.

PRIZES FOR ALL TOURNAMENTS AND MEETS

We can help you secure that local order

The Chas. M. Robbins Co.
ATTLEBORO, MASSACHUSETTS



Shell Cameo Brooches and = Belt Pins =

IN STERLING SILVER FLORENTINE WORK

FROM \$3.25 to \$7.00 Each

Send for a choice selection on memorandum

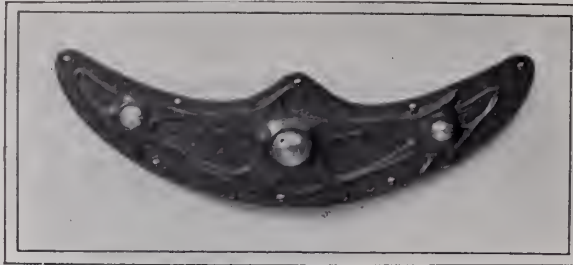

M. GUGENHEIM, Importer
 Brooches, Festoon Chains, Combs, Hat Pins, Collars, Jet Goods, Mesh Bags, in German Silver, Gilt Metal and Sterling
NEW YORK OFFICE 33 Union Square, Decker Building
PARIS 32 Faubourg Poissoniere

While in Italy I anticipated the daily growing demand for Cameos, and accordingly negotiated for such quantities as now enable me to uninterruptedly meet the heavy call for these goods.



Seamless Gold Plated Pins

FOR EVERY USE

Variety of Patterns in Plain and Engraved, in lengths one to four inches : : : : :

GUARANTEED GOLD FRONT, BACK AND SIDES

SEND FOR SELECTION

Maintien Bros. & Elliot, Makers of Jewelry for the Jobbing Trade

NO. ATTLEBORO, MASS.
 New York Office, 9-11 Maiden Lane



Chicago Art Metal Works
 Manufacturers of **INITIALS and MONOGRAMS**
 FOR PURSES, BAGS, BRUSHES, ETC.
 Monogram Fobs and Belt Buckles
 Write for Catalogue and Prices
63 Lake St., Chicago, Ill.

Roger Williams Silver Co.

Manufacturers of

The only practical Grape Fruit Knife and Anti-septic Shears; also Makers of the Common Sense Orange Knife.

See that Curve? (See cut) A child can use them.

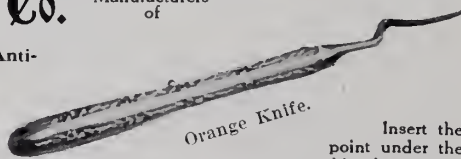
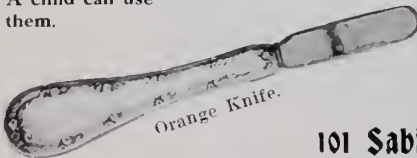

Orange Knife.

Insert the point under the outer skin, having the cutting edge toward you, and follow around, paring the cut skin without puncturing the inside pulp.

Samples and prices on application to the Factory

101 Sabin Street - Providence, R. I.

Gems and Precious Stones

Cloth, Postpaid, \$1.00

Published by

The Jewelers' Circular Pub. Co.
 11 John Street NEW YORK



Veil, Cuff and Baby Pins

An immense line. Many new designs supplementing our staple patterns—all of acknowledged beauty and easily sold.

Cameos A revival of an old-style decoration too good to remain in oblivion.
 Shell, Coral and others, mounted as Brooches, Stick Pins, etc.

Swastika Buckles Bracelets Buttons Charms Brooches Barrettes
 Combs, Hat Pins, Scarf Pins, Leather Trimmings

MILLER, FULLER & WHITING CO.
 Manufacturing Jewelers
 New York Office, 9-11 Maiden Lane NORTH ATTLEBORO, MASS.
 WE SELL TO THE JOBBING TRADE ONLY



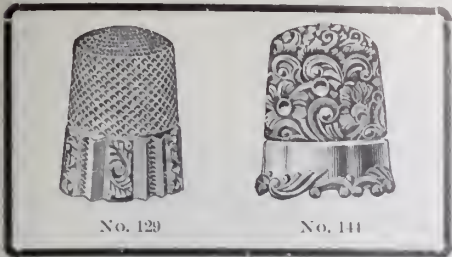

No. 129

No. 141

KETCHAM & McDOUGALL

Manufacturers

Gold and Silver Thimbles
Automatic Eye-Glass Holders
37 and 39 MAIDEN LANE
NEW YORK

Established 1832

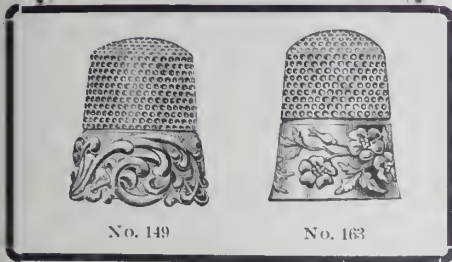

No. 149

No. 163

REMOVAL NOTICE

MABIE, TODD & CO.

Gold Pens

PENCILS, HOLDERS AND CASES
SWAN FOUNTAIN PENS

HAVE REMOVED TO
SILVERSMITHS BUILDING
15-17-19 Maiden Lane, New York

HOROLOGICAL DEPARTMENT
BRADLEY POLYTECHNIC INSTITUTE
Formerly Parsons Horological Institute
PEORIA, ILLINOIS
LARGEST AND BEST WATCH SCHOOL IN AMERICA
We teach Watch Work, Jewelry, Engraving,
Clock Work, Optics. Tuition reasonable. Board
and rooms near school at moderate rates.
Send for Catalog of Information



SHUROLDA



Automatic Scarf Pin Protector



14 KT. GOLD PLATE

PRICE 50 CENTS

The Stronger the Pull the Firmer It Holds

Samples and Prices on Application

FOR SALE BY JOBBERS OR DIRECT BY



To Release Pull the Ball

Pat. Mar. 12, 1907.
No. 847,164.

Pat. Mar. 12, 1907.
No. 847,164.

To Release Pull the Ball

Pat. Mar. 12, 1907.
No. 847,164.

STERN & CORN 71-73 Nassau St. NEW YORK

New York, April 29, 1908.

TO THE TRADE:

The great success which the *Shuolda* pin clutch has gained in the trade has brought upon us the envy of our competitors. A suit has been brought against us for alleged infringement. We have welcomed this suit and have done everything in our power to bring it to a *hearing*.

We beg to inform the trade that we shall take care of any suits brought in consequence of selling the *Shuolda*, and will protect them against any loss or damage.

The following letter from our patent attorneys explains itself.

Respectfully,

STERN & CORN.

New York, March 31, 1908.

STERN & CORN.

GENTLEMEN:—After a careful examination of the prior art, we have to advise you that the *Shuolda* Scarf Pin protectors which you manufacture are in our opinion NO infringement of any similar article made or for which letters patent have been granted.

Yours,

MUNN & CO.

SCIENTIFIC AMERICAN.

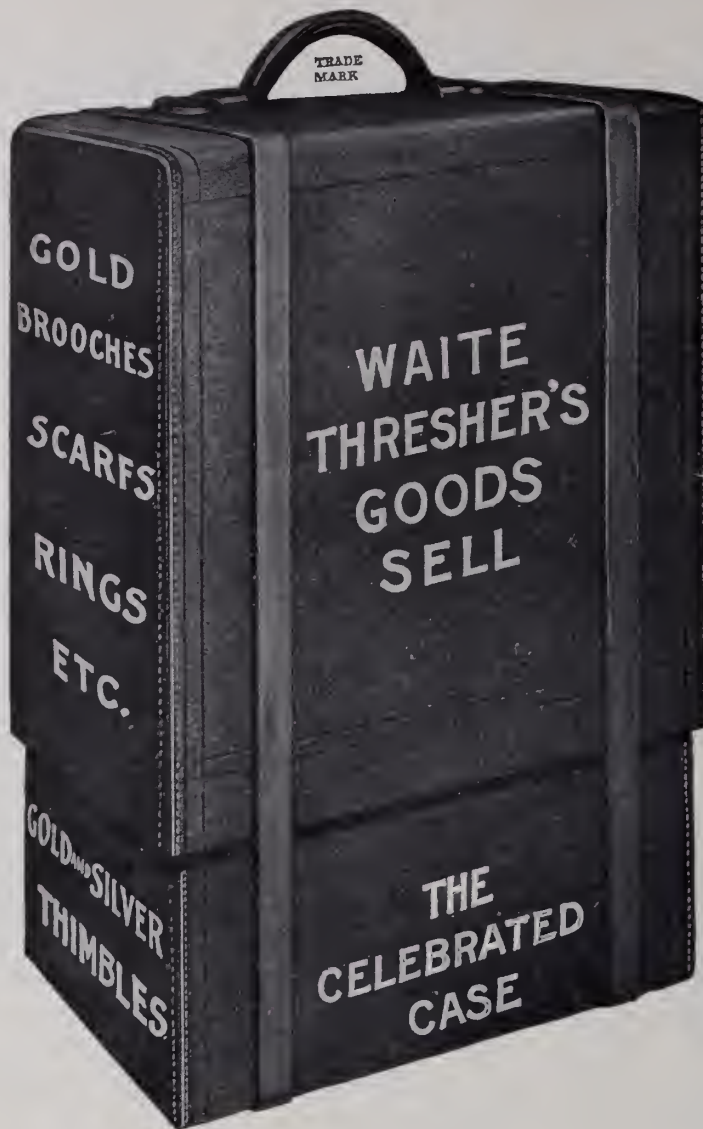

NEW YORK OFFICE
No. 7 Maiden Lane

CHICAGO OFFICE
1203 Heyworth Building

O. M. DRAPER CHAINS

ALL KINDS OF VEST CHAINS
PRINCESS, NECK AND GUARD CHAINS

We do not make as much noise as some of our friends but we are "there with the goods" and the *Jobbing Trade* handling our product for the last half century, know that our QUALITIES are genuine and can be depended upon, that our FINISH is unparalleled and that our prices are consistent.

If you do not handle O. M. DRAPER GOODS, we both lose.
We sell only to the Jobbing Trade.

Estate of O. M. DRAPER
Factory, No. Attleboro, Mass.

NEW YORK OFFICE
37 Maiden Lane

SAN FRANCISCO
506 Chronicle Building



The Gillette Safety Razor Set consists of a triple silver-plated holder and twelve double edged, thin, flexible, wafer-like blades (24 keen edges), packed in a velvet lined leather case. Price, \$5.00. Also made in Combination Sets in a variety of styles with toilet accessories retailing from \$6.50 to \$50.00 each.

Would You Have the Present Year Bring You Increased Patronage, Profit and Prosperity?

Do you realize that nearly every hour in the day some man is converted to the easier, quicker and more economical way of shaving himself with the

Gillette Safety Razor?

Our persistent and vigorous advertising in the leading publications of this country discloses — *and will continue to disclose* — beyond all question of doubt, the superiority of the "Gillette." It advocates the advantages of self-shaving and guides the man to your store with a five dollar bill to exchange for the best shaving device in this world.

You can readily see the wisdom of having the "Gillette" ready when he calls. The Standard Gillette Set retails at \$5.00 everywhere. Combination Sets from \$6.50 to \$50.00. Keep a good supply in stock. Write to-day for valuable selling information and prices.

GILLETTE SALES CO., 904 Times Bldg., New York City

Jewelry which gives Distinct Pleasure to its Wearer

This can be truthfully said of the F. & B. New Fashion Collar Pin and Supporter. The lower pin and support are in one piece, the upper pin being movable, and the entire support is worn on the outside of the collar, thereby adding a dainty touch to the Ladies' neckwear, and at the same time doing away with uncomfortable inner support. With many unique designs we are now ready for the Spring Season's orders.



1½ in. high No. 3963
2 " " 3969
2¼ " " 3975
THE "FASHION" PIN

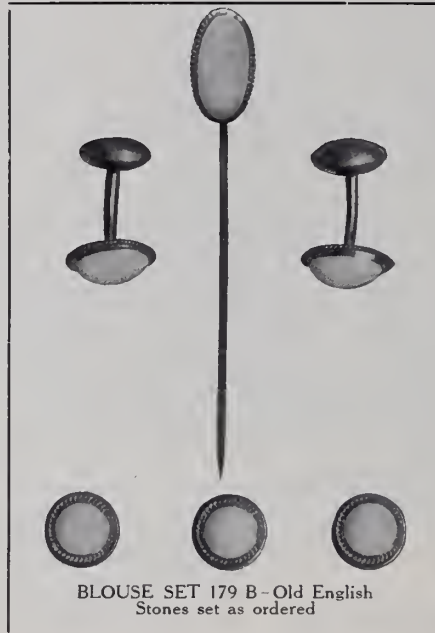

BLOUSE SET 179 B—Old English
Stones set as ordered



1½ in. high No. 3965
2 " " 3971
2¼ " " 3977
THE "FASHION" PIN

FINE GOLD FILLED COLLAR PINS. PATENTS PENDING

The practice of keeping to one color scheme in Jewelry is becoming an established fashion. Our New Blouse Sets, made up of Studs, Link Buttons and a Scarf Pin, all set with stones of the same shade, make pretty ornaments for the Summer Gowns.

We have, besides, a handsome line of Locketts and Chains, Bracelets and Link Buttons, Veil and Scarf Pins, Hat Pins and Brooch Pins, as well as Neck Chains and Pendants.

Our Sterling Silver Goods afford a choice selection of Toilet and Manicure Pieces, Table Ware, Vases and Candle Holders, suitable for June Weddings and Graduating Gifts.

Theodore W. Foster & Bro. Co.

Manufacturing Jewelers and Silversmiths

100 RICHMOND ST., PROVIDENCE, R. I.

NEW YORK: 13 Maiden Lane

CHICAGO: Heyworth Bldg.

CANADA: Kingston, Ontario

DECORATIVE ETCHING ON SILVERWARE.

I HAVE often wondered why the art of etching is used so little in metal work, especially in silverware, says A. F. Saunders in *The Metal Industry*; evidently its decorative possibilities have either been overlooked or are not appreciated, for surely this art is worthy of just as high a place among the handicrafts as any other form of hand work. It possesses a quality and refinement all its own that should appeal strongly to good taste; its adaptability and simple method of application recommend it as an ideal medium in which to express any decorative design in metal work. Etching is used quite extensively for inscriptions, scenic views, etc., on prize cups and trophies, but viewed from a purely aesthetic standpoint, such secondary use as this hardly does it justice.

Etching is no more costly to execute than chasing, engraving or any other hand work. I admit there is much silverware on the market that is called etched work, but in most cases it is rank imitation, usually die work. However, it is my purpose in this article to give an idea of the process and also the value of this effective hand work to the craftsman in metal.

We will take a silver vase as an example. To begin with, two very important points must be remembered—first, the parts etched or eaten away must be absolutely clean; second, the design if raised must be thoroughly covered with the etching paint or ground, the formula for which will be found further on. The object is first thoroughly cleaned with fine pumice and water, then dipped in the acid bath long enough to remove any oxide, thus giving it a smooth white surface to transfer the design upon. My method for this is tracing over the design previously drawn on thin paper that has been brushed over with rouge on its underside; this leaves a clear, clean outline for the filling in.

Care must be taken that the design is placed evenly and spaced properly. This is now filled in with paint, using a good grade water color brush (red sable best), care being taken to get as smooth outline as possible and the paint laid on evenly. The design filled in is allowed to dry thoroughly, then with hot beeswax brush over the bottom, inside, or any parts not to be etched to protect them from the acid. The object can be suspended in the bath either by a waxed cord or stick of wood.

This acid bath for etching silver is nitric 2 parts, water 2 to 3 parts; keep work moving slowly to ensure even depth of eating away. As to the depth most effective experience only can teach the time required in the acid. I have found that as

a rule with the above proportions of acid from 10 to 15 minutes is sufficient, watching the work carefully that none of the paint flakes off. When the required depth is reached wash carefully in clean water, dry thoroughly, then fill in with paint all the parts etched away. When this is dry it is ready for the scratching or shading, which is done with different sized points made of an old rat tail file; these must not be too sharp, as the object is to simply scrape away the paint, not to dig into the metal. This is done by using the scratcher as a pen or pencil, drawing and shading the design effectively.

Do not attempt to shade too much, as the simpler and fewer lines the better the result when finished. It is now ready for the second etching. The shaded lines are etched just deep enough to show up plainly when the piece is finally oxidized. The paint is removed with turpentine and the wax melted off, and when thoroughly cleaned of all grease is ready for finishing and coloring. The effect reversed is most attractive, etching away the design thus giving a stenciled effect and leaving the ground raised.

Another attractive effect can be had by etching different parts of the motif different depths, giving the effect of one layer of ornament upon another; also with two different colored metals one can be etched away. For instance, the silver plate to the copper ground, leaving the design in silver or gold on silver, or brass on copper. The effects thus produced are beautiful. Raising parts of the etched work on a snarling iron or punch also adds to the variety and is most effective in some designs. In ending I give the ingredients of the etching paint I use also the necessary materials:

Paint or ground: Asphalt 3 parts, pure beeswax 1 part, turpentine enough to cover; bring to boil, mix thoroughly and allow to cool. Keep in well corked bottle and add turpentine occasionally. Caution must be exercised in the boiling process as it is highly inflammable, also must not allow it to burn. For waxing use only pure beeswax slightly colored with powdered rouge. This is melted back into the wax pot when etching is finished, so there is no waste. Old rat tail files ground to a point and inserted in wooden handles or wound with coarse cord make excellent scratchers; three are enough. For acid bath use 40 per cent. commercial nitric acid and clear water. Keep this bath at about 60 deg. F. while etching. Turpentine removes the paints easily. On silver platinum oxidize is most effective to show up the etched work.

A Fine Presentation Set.

A VERY fine presentation set which has just been produced in London by the well-known firm of Elkington & Co. is shown on the front cover of this issue and comprises the following articles: A sterling silver replica of the "Warwick" or "Lysippus" vase; a sterling silver tea tray with massive gadroon and shell mounts, handsomely engraved; a pair of solid silver four-light candelabra beautifully chased with rams' heads and festoons after the antique.

The original of the vase, carved out of white marble, was discovered in the course of excavations at the ruins of Hadrian's Palace at Tivoli, near Rome. The central parts are ornamented with antique heads and enveloped with a lion's skin, head and paws, the thyrsus of Bacchus, the lituus of the Augurs and other embellishments of Bacchanalian subjects. The plinth on which the vase stands, as well as the tray, bear the following inscription:

"Presented by his brother officers to James Holden on his retirement from the position of Locomotive Superintendent of the Great Eastern Railway Company, January, 1908."

As can be readily seen from the illustration, all this presentation plate is of the best and most careful execution, and does credit to the designers and makers.

Foreign Trade-Marks in Austria-Hungary.

THE *Weekly Bulletin* states that the new treaty of commerce entered into between Austria and Hungary on Oct. 8 last year introduces certain new principles into the trade-mark regulations of those countries, especially Hungary. In a recent announcement the Hungarian patent office states that foreign subjects can now register their trade-marks at will either in Hungary or in Austria. It is usually in the interest of the owner to register in both countries at the same time.

The office of registration in Hungary is the chamber of Commerce and industry at Budapest. Foreigners are, however, required to designate upon the deposit of a trade-mark the name of the representative duly interested, who must be domiciled in Hungary, failing which the registration of the mark will be refused. In case of litigation the Hungarian authorities are the only competent judges. If an Austrian subject who has deposited his trade-mark in Hungary considers his rights injured by an Austrian mark, he must commence an action before the Hungarian authorities, and need not necessarily appeal to the Austrian authorities if his interests are limited to Hungarian territory.

The protection of foreign trade-marks deposited in Hungary is also valid in Bosnia and Herzegovina.

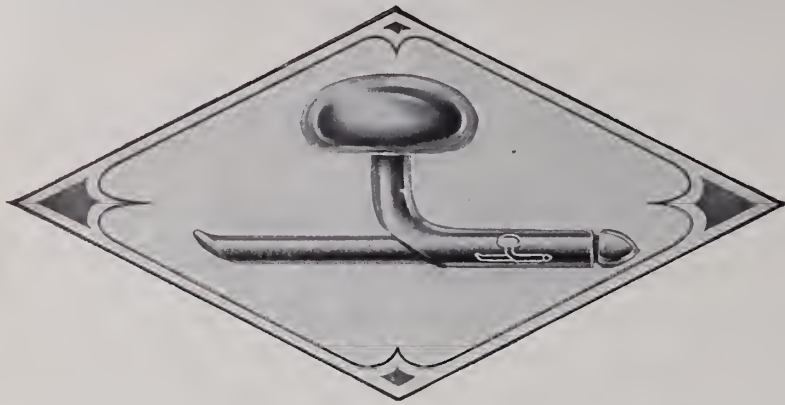

BUSINESS CONDITIONS.

UNDER the existing business conditions, the wise retail jeweler carries in stock a good line of every-day-called-for staple jewelry.

At the head of this class is **THE LARTER SHIRT STUD.**

The summer season is now near at hand and as there is always an extra demand for mother-of-pearl studs for summer wear, you can not afford to leave this part of your stud stock incomplete.

Don't lose sales by not having the styles your customers desire.

We carry the most complete line of mother-of-pearl studs in the market, with patterns to please all tastes, made in 14K gold also 10K gold and 14K gold filled. These two latter qualities to be had through progressive jobbers.

Be sure that your stud stock consists of a complete line of **LARTER SHIRT STUDS** and you will then be in a position to supply all stud customers.

REMEMBER, every LARTER SHIRT STUD is Guaranteed.

LARTER & SONS

21-23 Maiden Lane, New York, N. Y.

TRADE-MARK



REGISTERED IN U. S. PATENT OFFICE

Pearling in Australasia.

IN stating that Australia produces the largest share of the world's supply of mother-of-pearl, and that for quality and luster it is unsurpassed, Consul F. W. Godding makes the following report from Newcastle on this industry:

The most important centers of the industry are Thursday Island, Port Darwin, and Broome. In 1901 and 1902 the average price of shell was \$2,000 per ton on the London market. As the amount secured averaged four tons per boat per annum, and the expenses were comparatively small, large profits were realized. Naturally competition among the pearlers for first-class divers is keen, with a result that wages and bonuses are good. The divers and crews working the pearling luggers are introduced under agreement with the federal government. They are imported for a period of three years, and, on reaching port, are immediately signed on the vessel's articles, thus bringing them under the operation of the merchants' shipping act. The master is also compelled to furnish a bond of \$500 for every man employed, as a guaranty that at the end of three years the man will be deported to Singapore, the port from which the divers are recruited. Formerly the pearlers paid the divers \$10 per month, \$100 to \$175 per ton bonus, and, in many instances, from 5 to 15 per cent. for the pearls won. Though arriving as raw coolies, some of these Asiatics earned from \$1,000 to \$2,000 per annum, with keep.

From \$2,000 per ton in 1901 shell has gradually decreased in value, until at the last November sales held in London it had fallen to \$600 per ton. The divers, most of whom are Japanese, are well organized, having their clubs and benefit societies, and every Japanese, whether belonging to the crew, tender, or diving staff, is compelled by his countrymen to join. Everything pertaining to the welfare of the members is thoroughly discussed at the meetings, and they usually succeed in whatever demands they make. In the past their demands, whether deemed reasonable or otherwise, have always been granted by the disunited pearlers, but now these are determined to lower the cost of production, which movement has caused a strike.

One of the results of the union has been the success which has attended the "dummying" of boats. The divers soon save enough to purchase their own boats, with others working them ostensibly as owners, who secure the fishing license and transact the business connected with the work on a commission. The act which stipulates that no Asiatic shall hold a license can thus be evaded. The Japanese dominate the situation, for without their aid as divers pearl getting would cease.

Thos. Cairtis, who has a jewelry store at Gridley, Ill., was recently the victim of burglars, who got away with about \$300 worth of rings, all the watches he had on hand for repair, some bracelets and other articles were taken. The total loss is about \$700. There is no clue to the identity of the thieves, but blood hounds were sent for in the hope of apprehending the robbers and recovering the booty.

REPOUSSÉ WORK AND CHASING*

ILLUSTRATED AND DEMONSTRATED BY AN EXPERIENCED ARTISAN

(Continued from issue of April 1.)

FOLLOWING the period of general depression in the 10th century, England, with the rest of Europe, experienced a great artistic revival in the 11th century. Artists were no longer content with Byzantine models, but introduced a style of their own. During the succeeding two centuries the various ecclesiastical utensils connected with the Church service, though in great variety, were all designed after certain general types and models. The interchange of visits among the inmates of the various monasteries scattered over Western Europe, and, above all, the common interest taken in the crusades, made craftsmen work out similar ideas, though often working far apart. The great abbeys of Ely and St. Albans in England, in common with the various abbeys of the Continent, were, so to speak, schools of ecclesiastical goldsmiths, and most of their motives of design, as well as the various methods of working, were common knowledge. About this time English art became influenced by the Norman tendencies of Edward the Confessor, and the Romanesque, or Norman, style eventually became supreme, after the overthrow of the Saxons by William the Conqueror. The goldsmiths' art at this time borrow much from the architecture of the period. Stalks and leaves were twined round architectural columns, and tiny images of men struggling with dragons and other monsters were also used with good effect. The abbey of Ely, about this time, produced much work in gold and silver, and was eventually able to appease the anger of William the Conqueror by an offering of 1,000 marks, obtained by the sacrifice of a large number of gold and silver ecclesiastical objects which the abbey had accumulated.

THE 12TH CENTURY.

In the 12th century candlesticks were among the most elaborate of the many beautiful objects made in the service of the Church. One of the most elaborate still existing is the famous Gloucester candlestick in the South Kensington Museum. It is cast in three pieces of very white bell metal, probably containing a good proportion of silver. The decoration principally consists of figures of men and monsters (emblematic of the Christian Church and the powers of darkness), standing or struggling among intertwining stems of foliage, very typical in design of 12th-century work in this country. Round the knob are the four Evangelists, separated by silver bosses. The Latin inscription round the stem records that it was given by the Abbot Peter and his flock to the Church of St. Peter at Gloucester, evidently referring to what is now Gloucester Cathedral. The Abbot Peter mentioned in this inscription became Abbot of Gloucester in 1104, and died in 1113, so that the candlestick must have

been made between these two dates. It ranks among the finest examples of this type of work produced, and shows that England was not behind Continental countries at this period in the production of beautiful metal work.

Mathew Paris mentions, among other notable examples of English 12th-century work, two candelabra of gold and silver which were made at the abbey of St. Albans and sent as offerings to St. Peter's in Rome. In addition, he mentions a great silver-gilt reliquary, set with gems, made by the monk, Anketill, at the same abbey, and his pupil, Solomon of Ely. In the year 1241 A. D. Henry III., who greatly encouraged the various arts and crafts, was building Westminster Abbey, and he gave directions for the support of the goldsmiths employed on the shrine of Edward the Confessor. This golden shrine, which, from description, must have been one of the most sumptuous pieces of work ever produced, has long been stripped of its treasures. By the end of the 13th century the Gothic style had become general in England, as in other countries. Shrines continued to be made in great numbers, among the more important of which may be mentioned those erected to St. Alban at St. Albans, St. Erkenwald, at St. Paul's, St. Edmond at St. Edmonds Bury, St. Cuthbert at Durham, and St. Frideswide at Oxford. They were, as a rule, made like the Greek images, of wood covered with wrought sheets of gold, silver or other metal, decorated with filagree and repoussé work, as well as precious stones. On many of these shrines goldsmiths continued to be employed from time to time as persons bequeathed their personal treasures for some special adornment of the shrine of their favorite saint. In 1339 three London goldsmiths were retained for a year by the authorities of St. Paul's, in consequence of a large bequest of gold and jewels to the shrine of St. Erkenwald. Possibly the finest example of English silver work of the Gothic period is a crosier of William of Wykeham now preserved in the New College, Oxford, this being his own special foundation. Of secular objects of the Gothic period, practically nothing remains, the Coronation spoon now preserved with the rest of the Regalia in the Tower being one of the most noteworthy.

Before leaving the Gothic period, mention must be made of the royal gold cup now preserved in the gold ornament room of the British Museum, which, although of French origin, was for many years part of the English royal treasure, and which, after an absence of nearly 300 years, has again returned to this country. It dates from the end of the 14th century, the translucent enamels with which the cup is enriched being of the most sumptuous character and considered the finest example of that type of enameling still in existence. In 1391 the Duc de Berri presented it to Charles VI., and eventually it became the property of John, Duke of Bedford, then Regent of

France, who left it to his nephew, King Henry VI. It remained in English possession until the reign of James I., who, in 1604, presented it to the Constable of Castile, Juan de Velasco, on the occasion of the treaty of peace between Britain and Spain. It remained in a Spanish convent until 1883, when it was sent to Paris to be sold, as the convent was then urgently in need of funds. Eventually, in 1891, it was acquired by Messrs. Wertheimer, of London, for £8,000, and ceded by them to the nation for the same sum.

(To be continued.)

A Novel Baptismal Font Made by a San Diego, Cal., Jewelry Firm.

SOMETHING decidedly novel in the way of baptismal fonts was recently completed by Joseph Jessop & Sons, San Diego, Cal., for the Church of St. James-by-the-Sea, a new Episcopal edifice which has been erected at La Jolla, one of San



A NOVEL BAPTISMAL FONT.

Diego's charming suburbs. The unique features of the font are two immense shells from the South Sea islands, which are united at the back to form the basin to hold the baptismal water. The edges of the shells are rimmed with solid silver and a silver plate is imbedded in one of the shells stating that the font is presented to the church by the children of the Sunday school.

The stand which holds the shells is four feet in height and is made of iron. The whole design is very pleasing, and not too ornate for the sacred use to which it is to be put. The font is valued at \$1,000.

Benjamin F. Washtler, Ashkum, Ill., is now at San Dimas, Ill.

*All rights reserved. Copyright, 1907, in the United States by the Jewelers' Circular-Publishing Co., and in Great Britain by the Watchmaker, Jeweler, Silversmith and Optician.

LOUIS KAHN

MOSES KAHN

SAMUEL H. LEVY

L. & M. Kahn & Co.

Importers and Cutters of

DIAMONDS

170 Broadway, cor. Maiden Lane, New York

AMSTERDAM: 2 TULP STRAAT

CUTTING WORKS: 29 GOLD STREET

Arnstein Bros. & Co.

Importers and Cutters of

DIAMONDS

65 Nassau Street

New York

LONDON: Audrey House, Ely Place

AMSTERDAM: 6 Tulp Straat

ALBERT LORSCH

N. Y. Telephone Call, 2161-2 John

ALFRED KROWER

ALBERT LORSCH & CO.

LORSCH BUILDING, 37 and 39 MAIDEN LANE, NEW YORK

131 Washington Street, Providence, R. I.

CUTTERS OF
DIAMONDS

REIGNING PARIS FASHIONS.

JEWELRY NOVELTIES SEEN IN FRANCE'S CAPITAL.

PARIS, April 18.—There is much variety in tea, coffee and liquor sets, the silversmiths vying with each other in producing quaintly pretty as well as useful objects for the serving of these fashionable beverages. However, the novelties now seen in Paris emanate rather from England than France. Silver tea trays at least three-quarters of a yard long hold a tall coffee pot, the sugar bowl and cream jug in either burnished or beaten silver—with, however, a preference for the former finish. These salvers are only sufficiently wide to set the coffee equipage and the cups in a row.

The porcelains employed are in solid colors, the delicate Saxe and turquoise blues, a pale, clear yellow, a deep Du Barre rose, an exquisite heliotrope, a rich *rouge flambe* and opaque white. Some of the cups are silver rimmed, while others show the conventional gold band. These are represented in Coalport, Spode Royal Worcester, Wedgwood, and other well-known English porcelains, all quite undecorated. Sometimes a polished oaken tray with silver handles is substituted for metal.

Stylish are silver-handled objects for holding the after-dinner requisites. The coffee set stands on a solid base; on either side of the high handle the cups are set low down, each in its own frame, while on a silver standard the cut crystal liquor glasses are suspended. Another shape curves up gracefully on each side, the cups and saucers finding their place on a light framework. There are afternoon tea tables with tops of hammered silver, the plates being supported on a framework below. The squatly teapot, etc., with cups along the same lines, are of silver, the broad-mouthed cups also low and flaring. For the favorite chocolate there are substantial and elegant pots, high in shape and bound with silver, a brilliant red and a bright yellow being the colors of predilection.

The exquisite pink Dutch copper with a highly burnished satiny surface is much employed in tea and coffee sets and other table utensils. The shapes vary, for it is an accepted fact that the coffee pot be of tall and slender form, the sugar and cream corresponding. On the contrary, the tea service takes on the squatly shapes so popular in Holland, and with scarcely any decoration save an etched rim and rather ornate handles, the service set upon a salver of the same metal. Brass is also in favor, often usurping the place of silver or copper. Its polished surface has the luster and almost the color of gold. A tea set in which engraved glass tumblers held in brass frames replace cups is intended for Russian tea in which lemon is squeezed instead of cream.

There are any number of pretty and convenient devices for serving beer, liquor and iced drinks. Cosy little *tête-à-tête* sets with a Dutchy-looking glass bottle and two small clear glasses through which the connoisseur can observe the seductive green of *crème de menthe*, the rich brown of curacao and the yellow or pale green of the famous *chartrreuse*. There are besides tiny silver trays which contain but one glass set in a silver framework intended for the serving of each

person separately. A generous glass pitcher and tall glass is to contain the amber beverage of the beer drinker. More generous is a wide crystal salver with a tall and slender carafe surrounded by a dozen tiny glasses for cordials.

The very long and narrow coffee equipage has been reproduced in silver, apparently for the use of a doll, but in reality intended for a cabinet piece. It is perfect, the coffee pot, etc., being no more than two inches in height, while the cups are of Lilliputian proportions.

A new idea in table decoration shows a circular salver made of a mirror, and around it a number of low glass vases for flowers. In the center is a white crystal bowl for fruit, and grouped around are smaller ones for bonbons. Another handsome ornament showed a gilded basket flower filled and drawn by naked boys in biscuit, while garlands of living green connected it with several smaller ones of similar design. Movable and intended as an adjunct to floral decoration for the dining table are posts of faceted glass or in floral engraved designs connected by silver chains. Quite novel was a tea set of shaded heliotrope Carlsbad glass, the teapot cream jug and sugar bowl of the same material set on a mirror plateau. Ornate corks show gold or silver tops finished with national or colored flags, or a woman in characteristic national costume.

A small and attractive novelty is a bracelet, either an extensible one or in a heavy chain pattern, to which is secured by a ring a metal or suede bag. Suede bags show handles formed of knotted silk cords finishing in ornate tassels. Convenient are bags of morocco of the fashionable colors, with an outside pocket which is fastened by means of a gold or silver pencil passed through a slit. Grooved and undressed kid in stripes is new, the raised stripes having the appearance of velvet with dul'er ones between.

Very tiny real pearls threaded in a pattern like the common bead necklaces are shown at a place on the Rue Royale. White enamel lozenges on a bracelet enclose links formed of raised flowers in reddish gold between bars of green gold. The oak leaf encrusted with diamonds makes a handsome showing, the acorns and cups being realistically perfect and in bronze gold.

Of somewhat barbaric taste is a cross as long as one's hand and composed of very large Ceylon sapphires surrounded by diamonds and picked out with rubies.

For jewelry made to correspond in color and style with certain toilettes, the semi-precious stones are lavishly employed, as are also the less expensive irregular-shaped pearls which are threaded on a delicate gold chain, while the colored stones intersect heavier links of gold, silver or platinum.

Straw-colored diamonds, rare and expensive, are greatly in favor for the very large drops which depend from thin chains. Pink pearls of great beauty composed a necklace, the pearl-shaped stones being used as pendants, while a narrow thread of diamonds served as a support. Pink coral replaces pearls in less expensive jewelry.

The favorite and fashionable blue and green used in millinery and dressmaking has its counterpart in jewelry, the irides-

cence being represented by the association of emeralds and sapphires, but more frequently reproduced by the exquisite translucent enamels. Cuff links like posts come in these colors. Rococo baskets overflowing with flowers in vari-colored stones are copied from ancient mediæval jewelry.

The grape as a *motif* has again cropped up, and, artistically treated, is most effective. A brooch of quite large size was composed of grape leaves and tendrils in shaded green and bronze, while clusters of the fruit expressed in small pearls hung from the vine.

While beads are not as much worn as formerly, those of semi-precious quartzes are still in demand. Amazonite, both pale and light, makes ornate necklaces, and sometimes a big heart cut out of a single stone and uncut acts as a pendant. The lovely pink quartz is also a favorite, while there is a revival in favor of gold beads.

Buttons of these quartzes, with also amethyst matrix lapis lazuli and malachite, are used on handsome coats and waistcoats; in fact, the button is a real *article de luxe* nowadays. Gold star-dotted amber and dark tortoise shell, Saxe Sèvres and Wedgwood exquisitely painted miniature buttons in fine translucent enamels of painted heads, others reproduced to match the velvets and silks for elegant gowns, and those of colored gold in repoussé or etched designs. Buttons of Toledo damascene gold inlays on steel (a secret ravished from the Moors), gold filagree encrusted with tiny rubies, diamonds or turquoises, buttons of turquoise matrix with lace-like settings, buttons of changeable sheen in dragon fly tints, others of silver, those cut from the woolen vest of a Dutch peasant being both handsome and substantial, with plain or carved coral, also gun-metal, diamond encrusted, are prominent.

Hat pins are both expensive and artistic, fashion necessitating that the hat pin correspond to the color of the hat and veil. Enormous pierced gold or silver repoussé, etched and painted miniatures are among handsome hat and veil pins. Most of them are large in diameter, a late pattern showing a tremendous beetle or coiled serpent, the legs clawing an embossed and gem-set ring. Others of turquoise shell go with gold tracery or with heads of carved coral.

COUNTESS DE MONTAIGU.

Foreign Trade-Marks in Japan.

THE *London & China Telegraph* states that it is announced on semi-official authority that negotiations are in progress between Great Britain and Japan with regard to the use by Japanese firms of British trade-marks. It is said that an agreement will shortly be concluded for the protection of British trade-marks in the Far East. Up to the present time Japanese courts have held that no foreign trade-mark known and used in Japan before the enactment of the law in 1899 was entitled to protection, unless it had been actually registered in the patent bureau.

Many foreign patents were registered by Japanese, who are now the owners of such trade-marks in Japan.

W. J. Collins, Warren, Ill., has been succeeded by Karl M. Keyes.

EDUARD VAN DAM

CUTTER OF

DIAMONDS

— CUTTING SHOPS: —

ANTWERP.

41 Rue de la Province (Sud.)

CABLE ADDRESS, MADNAV

NEW YORK

437-439 Fifth Ave.
Cor. 39th St. Knabe Bldg.

TELEPHONE, 5879 38TH ST.
CABLE ADDRESS DEVRIVAN

AMSTERDAM

55 Ruysdaelstraat

CABLE ADDRESS, MADNAV

LONDON OFFICE, 22 Holborn Viaduct

AMSTERDAM
2 Tulpstraat

LONDON
40 Holborn Viaduct

OPPENHEIMER BROS. & VEITH.

CUTTERS OF DIAMONDS.

Cutting Works
43-45-47 John Street

NEW YORK
65 Nassau Street

R., L. & M. FRIEDLANDER

IMPORTERS OF

DIAMONDS

30 MAIDEN LANE, - - - NEW YORK CITY

NOTICE

BRUHL BROS. & HENIUS CO.

WILL REMOVE ABOUT MAY 1st TO THE

SILVERSMITHS BUILDING

15-17-19 Maiden Lane

NEW YORK

THE NEWS FROM ENGLAND

Trade Shows Little Improvement—Why Manufacturers Are Not Exhibiting at the Franco-British Exhibition, Which Opens May 11—Sheffield, Birmingham and Coventry Still Complain—Lively Movement Toward Technical Education—"Time-Saving" Bill Progresses—Diamond Markets Steady.

LONDON, April 18.—So far it is impossible to record any general improvement in British trade, jewelers, silversmiths, electro-plate workers, watch and clock-makers, engravers, enamellers, chasers and cutlers all report business quiet. In London practically everyone is tired of trying to think out the repeated question, Why is trade so continuously bad? The Franco-British Exhibition which opens May 11, will, it is hoped, bring a good number of buyers of luxuries into London and thus help to give a fillip to the jewelry, silversmithing and horological trades.

* * *

The exhibition is progressing very favorably, but so far as the jewelry and kindred trades are concerned practically none of the firms who manufacture for the purpose of sale to the storekeeper is exhibiting. This is largely due to fear of the storekeeper who is always ready to cry "Wholesale-Retailing" if an actual manufacturer shows his goods and his name. I am heartily "in accord," to use the N. A. G. phrase, with the fight against wholesalers retailing and so filching custom from the legitimate storekeeper, but I feel just as strongly that a movement which handicaps a bonafide manufacturer in an attempt to push his name and his goods by means of exhibitions is detrimental to the trade as a whole and to the National interest. It is this narrow-minded policy of keeping the silversmithing and jewelry manufacturer in the dark which has kept Birmingham and Sheffield from being represented by their wholesale manufacturers. Of the three storekeeper-manufacturing firms showing, Elkington & Co. have their factory located in Birmingham, Mappin & Webb have factories in Sheffield and London, and Messrs. R. & S. Garrard are an old London firm of silversmiths who actually employ a large staff of silversmiths over their shop in the heart of the West End. Most of the other exhibitors are storekeepers pure and simple.

* * *

But to return to the question of trade. Sheffield, looking to the Spring as a time when manufacturers are usually encouraged to make new designs, is somewhat disappointed at the small improvement, but the demand is a little more satisfactory and a deadly dulness no longer prevails. The value of Sheffield cutlery exports for March are about £7,000 less than in the same month of last year! Birmingham still complains of "small orders" and the scarcity even of these, while Coventry is by no means busy with the manufacture of watches. Scotland and Ireland complain very much. In the ordinary cities retailers complain that sales are small and few but that they are hoping that things will brighten.

* * *

Here in Great Britain there seems to be a very lively movement just at present

toward technical education. In Scotland, particularly in Edinburgh, where is situated the famous Heriot's College, founded by one of the greatest and richest of Scotch goldsmiths, there is a keen move in the direction of providing technical education for gold and silversmiths. In London the big meeting of manufacturers held in the Hall of the Worshipful Company of Goldsmiths, is likely to lead to very useful results, particularly in view of the opening of the new Central School of Arts and Crafts, the first floor of which is devoted entirely to the gold and silversmithing craft with ample space to accommodate comfortably at one time 300 students. In the basement are a couple of large rooms devoted to the heavier branches of the art metal-workers' craft, which will accommodate about 40 students.

* * *

The question of putting back the hands of the clock during certain months of the year so as to arrange a longer day during Summer months has gone along with a better prospect than at first appeared possible. The second reading has passed the House of Commons with the result that the Bill has gone into committee, but whether this is a means of licking it into workable shape or of killing the project time only will show. Meanwhile considerable discussion is raging as to the utility of the so-called "Time Saving Bill."

* * *

So far as the diamond markets are concerned everything remains steady. Prices are not likely to alter despite the fact that sensational articles have appeared in the daily press to the effect that "Diamonds are cheaper."

ST. GEORGE.

Death of Karl Breuninger.

WASHINGTON, D. C., April 22.—This city has sustained another loss to its pioneer jewelry trade in the death of Karl Breuninger in his 76th year. While the immediate cause of death was heart failure, Mr. Breuninger had suffered for nearly two years from the result of an accident.

Mr. Breuninger was a native of Germany and learned his trade as a manufacturing jeweler in Stuttgart. He came to America in 1852, and resided for several years in Philadelphia. He removed to Washington in 1861 and started business in the old Bank of Washington building. From there he moved to C St., between 9th and 10th Sts.; then to the south side of Pennsylvania Ave., and lastly to his present location, 929 Pennsylvania Ave., where the business will still be carried on by his son, Arthur.

Mr. Breuninger was the designer of the United States Marine Corps device, years ago, when the corps was in its infancy, and he has been termed the dean of the jewelry manufacturers of this city. He leaves a widow, one son, five daughters, four grandsons, three granddaughters and one great-granddaughter.

Death of E. S. Ettenheimer.

ROCHESTER, N. Y., April 22.—Elias S. Ettenheimer, one of the oldest business men of Rochester and for many years head of E. S. Ettenheimer & Co., jewelers, died Monday morning at his home, 46 Chestnut St., aged 89 years.

Mr. Ettenheimer was born in Ederheim, Germany, July 10, 1819, and came to America 70 years ago. For a while he lived in Syracuse, but came to Rochester more than 60 years ago and went into the jewelry business. The first store Mr. Ettenheimer conducted in Rochester was in the old Smith Arcade, where the Rochester Trust & Safe Deposit Co. building now stands. Later he moved into the old Ellwood building, and



THE LATE E. S. ETTENHEIMER.

when that was torn down he moved to the old Masonic block on Exchange St. He returned to the Ellwood building as soon as the new structure was completed, and since that time the store has remained there. Twenty-nine years ago he retired, and, although the business he founded retained the firm name, he had no active interest in it for some time. Six years ago advancing age began to make itself felt, and he grew gradually weaker until for the past two months he had been confined to his bed.

Despite his years Mr. Ettenheimer always took an active interest in the affairs of his city until very recently. He was of an intensely charitable disposition and at the time of his death his name was on the rolls of all the important local organizations devoted to the assistance of the needy. He was a member of Valley Lodge, No. 109, F. and A. M., and was always ready to do anything for the furtherance of the interests of the organization. He was also a director of the Security Trust Co. and of the Monroe County Savings Bank of this city.

Mr. Ettenheimer was married in 1851 to Miss Lucy Leiter, who died 17 years ago. He is survived by his son, S. L. Ettenheimer, of this city, and by a daughter, Mrs. Fred Myers, Seattle, Wash.

REGISTERED



TRADE-MARK

RINGS

REGISTERED



TRADE-MARK

RINGS are always in demand, and are always salable, provided you have the right kind to sell. We have—

RINGS of every description: signet rings, diamond rings, fancy rings, rings of every style and combination of stones.

RINGS that satisfy the most critical and appeal to every taste and fancy.

RINGS You can sell. *Write us or wire us any time. We are always ready for your order.*

HAYDEN W. WHEELER & CO., Importers

2 Maiden Lane, NEW YORK, N. Y.

Phone, 7365 Cortlandt

AMSTERDAM, 2 Tulp Straat

LONDON, 50 Holborn Viaduct

ORDER

DIAMONDS

ON MEMORANDUM FROM

ALFRED H. SMITH & CO.

170 BROADWAY, NEW YORK.

Corner Maiden Lane.

Also 475 FIFTH AVENUE.

London,
6 Holborn Viaduct.

Chicago,
103 State Street.

CROSSMAN COMPANY

BAROQUE PEARL BAR PINS

3 Maiden Lane, New York

Cable Address: "LEOGOLDIE" N. Y.

Telephone. 4115 Cortlandt Amsterdam, 2 Tulp St.
Paris 27 Rue Drouot.

LEO. GOLDSMITH

IMPORTER OF

Diamonds and Precious Stones

9, 11 & 13 Maiden Lane, N. Y.

Diamonds, Rubies, Sapphires, Emeralds,
Opals, Olivines, Pearls, Half-Pearls, Tur-
quoises, Reconstructed Rubies, Recon-
structed Sapphires.

TURQUOISE

Matrix-Turquoise

BEST THE WORLD PRODUCES

Exquisite Color
and Markings



No. 222

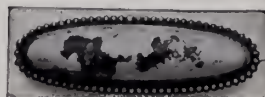

No. 316

SEND FOR CATALOG

Showing 133 different sizes and shapes
of MATRIX-TURQUOISE STONES
ready for Mounting.

The Arizona Turquoise Mines Co. Inc.

Cutting Works and Sales Office:

171 BROADWAY, NEW YORK

Telephone 5728 Cortlandt

Jos. Brown & Co. Refuse to File Schedules—Unofficial List of Creditors Compiled.

CHICAGO, April 24.—Through their attorney Hugo Pam, Jos. Brown & Co., bankrupts, have refused to file a schedule of their liabilities. The receiver, the American Trust & Savings Bank, claims its people can't do it without the assistance of the bankrupt. From various sources THE CIRCULAR-WEEKLY has compiled the following list of creditors. Firms with no amounts to their names are creditors for less than \$100. As there was no absolute data for verification, the list cannot be vouched for as undeniably correct. The total indebtedness is about \$180,000. The creditors include:

Secured Claimants. Ben Roth, \$2,000; S. M. Jess, \$5,000.

Unsecured Creditors. Arustine Bros. Co., \$5,361; A. Abraham Co.; Jos. E. Allen; Alshuler Bros., \$618; American Electric Novelty & Mfg. Co.; American Safety Razor Co., \$165; American Swiss Watch Co., \$3,805; Attleboro Chain Co., \$500; Attleboro Mfg. Co., \$636; Austin & Stone, \$138; L. Barnett & Co., \$421; Bay State Optical Co.; W. H. Bell & Co., \$1,038; P. A. Bennett & Co.; J. D. Bergen & Co.; Benster Electrotyping Co.; S. O. Bigney & Co.; the Bishop Co., \$124; W. & S. Blackinton Co., \$822; Bleadon Bros.; A. H. Bliss & Co.; Bliss Bros. Co., \$1,594; Bonner & Co., \$4,264; Bradner, Smith & Co., \$146; G. G. Breitenbach & Co., \$1,258; D. F. Briggs Co., \$1,174; George L. Brown, \$537; G. Buehsbaum & Co., \$184; A. Bushee; Cambridge Novelty Co.; Capron & Co.; Central Optical Co., \$166; Chicago Case Mfg. Co.; Clark & Coombs, \$104; Claus Shear Co., \$1,656; Cohannet Silver Co.; F. M. & J. L. Cobb, \$511; F. H. Colegrove & Co.; Combined Tool Co.; P. A. Coon Silver Mfg. Co.; Corning Cut Glass Co., \$2,446; Coulter Optical Co.; Crystal Glass Co.; P. J. Cummings Co., \$823; Cutler Jewelry Co., \$238; B. H. Davis & Co., \$5,567; Dennison Mfg. Co.; DeRoy & Reiss Co.; Diamond Point Pen Co., \$771; Hipp, Dilidheim & Bro., \$4,261; E. R. Dumont; Dunn & Rodenherg, \$600; Edgebrook Cut Glass Works; Elm Mfg. Co.; Electric Chain Co., \$900; Esser & Co.; Ettlinger Mfg. Co.; Excelsior Mfg. Co.; F. & F. Felger, \$174; Marshall Field & Co., \$445; Finberg Mfg. Co., \$1,262; J. H. Fink & Co.; J. M. Fisher & Co., \$770; Fontneau & Cook Co., \$2,100; Theodore Foster & Bro. Co., \$288; Fox & Co.; Freedman Bros.; B. S. Freeman & Co., \$1,004; Freeman-Daughaday Co.; French Process Co.; Fry Bros.; M. Goldmuntz, \$917; Goldsmith Bros., \$522; Goldsmith & Harzberg; Gordon & Morrison; Oscar Gott, \$403; Wm. C. Greene & Co.; F. P. Guild Co.; H. F. Hahn & Co.; Hammel, Riglander & Co., \$1,900; Hansson & Bennett; Harding Optical Co.; F. A. Hardy & Co.; W. J. Hartman Co.; A. Hirsch & Co., \$579; Hold-On Clutch Co.; Leon Hirsch, \$1,011; Hirsch Flasher Co., \$2,100; I. Hochberger, \$525; Holsman & Alter; Horton, Angell Co., \$426; Illinois Watch Co.; Illinois Watch Case Co., \$15,000; Imitation Typewriting & Add. Co.; Robert H. Ingersoll & Bro., \$600; Inlaid Co.; International Silver Co.; International Watch Co., \$204; Irons & Russell Co., \$132; Jennings Silver Co., \$109; Jewelers' Circular Pub. Co.; Kantor & Scheff, \$832; Keller, Becker & Co., \$297; Ketcham & McDougall; Julius King Optical Co.; Kohinoor Cut Glass Co.; Kronberg & Block; S. Langsdorf & Co., \$104; H. Lederer & Bro.; S. & B. Lederer Co., \$1,496; H. G. Lefort; Robert Levy, \$267; S. Lindenborn, \$2,700; P. & A. Linton; Edwin Lowe & Co.; R. B. MacDonald; Mackey & Elias; Manchester-Smith Co., \$166; Manhattan Chain Co.; Louis Manheimer & Co., \$1,900; Marden & Kettley Co., \$998; C. A. Marsh & Co., \$666; Martin, Copeland Co., \$489; M. A. Mead & Co., \$1,950; Merchants' Trans. Ins. Und.; Meriden Cutlery Co., \$729; H. D. Merritt Co., \$563; A. C. Messler Co., \$954; Charles Moe; Mohawk Brush Co.; Moore Mfg. Co., \$160; Morgan Jewelry Co., \$3,582; F. G. McDermott & Co.; E. S. McLaughlin & Co.; McRae & Keeler, \$713; National Clock & Mfg. Co., \$197; National Optical Co., \$483; New England Pearl Co.; New Haven Clock Co., \$703; New York Standard Watch Co., \$778; North American Watch Co., \$2,300; Oppenheimer Bros. & Veith, \$1,183; Ostby & Bar-

ton Co., \$1,711; Pairpoint Corporation, \$1,337; Peerless Chain Co.; Peerless Optical Co.; Philadelphia Watch Case Co., \$1,871; Pilcher-Hamilton Co.; A. & J. Plaut, \$1,466; Providence Stock Co., \$2,884; Jules Racine & Co., \$5,800; Rapid Addressing Machine Co.; Regnell, Bigney & Co.; W. Richert & Co., \$129; J. Resnick Trunk Co.; Rhode Island Novelty Co.; W. F. Richards & Co.; M. D. Rider & Co.; J. Rogers Silver Plate Co., \$625; Wm. A. Rogers, \$1,427; Adolph Rosenberg; M. & F. Rosenberg; Schickerling Mfg. Co.; Scofield, Batten & Co., \$112; Schultz, Leiss & Co.; Schuster-Bohnsack Co.; Adolphe Schwab, \$2,600; J. Schwartzkopf & Co., \$123; F. H. Sadler & Co., \$1,071; Saffir Bros.; Jacob Strauss & Sons, \$1,416; Standard Chain Co., \$160; Shaler, Hirtgerink Co.; Shiman & Eisenstein, \$1,946; N. Shure Co.; Siegel, Rothschild & Co., \$844; R. F. Simmons Co., \$825; Standard Chain Co.; Star Watch Case Co., \$16,000; George Steere; M. S. Stern, Stevens, Maloney & Co.; W. A. Starley Mfg. Co.; Superior Comb Co.; Sussfeld, Lorsch Co., \$725; Swartchild & Co.; Swiss Watch Import Co., \$987; Adolph Tanzer; Taunton Pearl Co.; Taylor & Jopson, \$422; Seth Thomas Clock Co., \$700; Trenton Watch Co.; Tucker & Norton; Trenton Trust & Safe Deposit Co., \$566; Universal Stamping Works; United Comb & Novelty Co., \$300; Wadsworth Watch Case Co., \$3,500; White, Mathewson & Co., \$167; R. Wallace & Sons Mfg. Co.; Waterbury Clock Co.; Weaver Mfg. Co.; O. E. Weidlich & Co., \$191; S. Weinstein & Co.; Harry L. Weisbaum; Weiss Mfg. Co.; Weizneger Bros., \$750; Western Clock Mfg. Co., \$200; Western Picture Frame Co.; The D. A. White Co.; James White Paper Co.; Zare White; Williams & Anderson; Williams & Payton, \$101; J. Wodiska, \$3,280; Yawman & Erbe Mfg. Co.; Ziruth Kaiser Co., \$130; Rogers & Hall Co.; Sabath Safe & Lock Co.; Chicago American; The Inter-Ocean, C. P. Engelhard & Co.; Cyrus Price & Co., \$2,800; Shiman Bros. & Co.; Thompson & Summerfield; Chicago Telephone Co.; People's Gas Light & Coke Co.; M. F. Edwards Co.; F. W. Gessner & Co.; Lancaster Silver Plate Co.; A. Suderor; Austin Stone; Manufacturing Jeweler; Henry Lederer; Association Jeweler; Barnes-Crosby Co.; M. Cummings; Mercantile Transfer Co.; N. S. Gordon; William Dixon, Inc.; Charles H. Wood Co.; H. B. Lindsay; Victor F. Lawson; E. F. Lathrep; F. A. Bower; H. Hinzanga; Adolph Loeb & Sons.

Lafayette Call Commits Suicide in His Store at Waynesburg, Pa.

PITTSBURG, Pa., April 24.—Lafayette Call, a former well-known jewelry salesman for Simpson, Hall, Miller & Co., fired a bullet into his heart at his place of business in Waynesburg, Greene County, Pa., several days ago and fell dead. Call had been in poor health for some time, which is given as the cause of his taking his life. Recently he had engaged in the music business, having left the jewelry trade, and had become despondent because of his illness.

Mr. Call went to his store about 7 o'clock in the morning, and when a small boy started to enter, he beckoned to him not to come in. A short time later a friend happened by, and seeing that everything was not right, went into the store and found Call in an unconscious condition. He summoned medical aid, but the doctors pronounced Call dead. A pistol lying under his desk told the tale of his demise. The tragedy was a great shock to his friends.

Mr. Call, who was about 40 years old, was well known in Pittsburg, and the announcement of the shooting caused intense surprise. Call was also well known throughout the central west, having traveled for the wholesale and jobbing house mentioned for some time. He is survived by a widow and one child and his aged parents. Call was buried at Waynesburg.

Detroit's Auctioneers' Licensing Ordinance Brought Before Council Ordinance Committee.

DETROIT, Mich., April 23.—When the new auctioneers' licensing ordinance, drawn up by the Jewelers Board of Trade and Wholesalers' committees, was brought up before the council ordinance committee, yesterday, there was an attendance of jewelers present to back it up such as has rarely been seen in the city. Wholesalers, retailers and manufacturers united to demonstrate to the aldermen that such a measure is necessary.

Indignation aroused by the practices of certain fake auctioneers during the past holiday season caused the agitation for the new measure. President Frank M. Kennedy, of the Jewelers' Board of Trade, led in the argument and he was supported by W. C. Noack and others. The committee was favorably impressed but will give the auctioneers a hearing and some amendments may be made. Alderman Heineman brought a laugh by mistaking the delegation for auctioneers.

Among those present were: Frank M. Kennedy, Kennedy Optical Co.; W. C. Noack, Noack & Gorenflo; Chas. A. Berkeley; Robert Traub, Traub Bros. & Co.; Wallace Kay, John Kay & Co.; Chas. W. Warren; Hugh Connelly; Frank Kunz and A. E. Rogers, Kunz & Rogers; A. E. Patterson, Burr, Patterson & Co.; S. Friedberg, J. Friedberg & Son; J. H. Garlick; L. Guthrie, E. H. Pudrith Co.; W. F. Schultz; Henry Luths, Luths, Dorweld, Haller Co.; L. Black; H. Tomlinson, Tomlinson & Willets; F. Strangsen, Traub Bros.; Clarence Enggass, Adolph Enggass Jewelry Co.; A. E. Charlesworth, Charlesworth Optical Co.; Geo. T. Orth, Albert Schaub.

Creditors File Involuntary Bankruptcy Petition Against D. & A. Brinker, New York.

An involuntary petition in bankruptcy was filed last Wednesday in the United States District Court, New York, against David Brinker and Abraham Brinker, individually and as co-partners composing the firm of D. & A. Brinker, wholesale dealers in diamonds and jewelry, 47 Maiden Lane, N. Y., by the following creditors: S. K. Merrill Co., \$600; Dunn & Rodenberg, \$150, and Frolichstein, England & Klein, \$20. It is alleged that the brothers are insolvent, and that while insolvent they made preferred payments.

Judge Hough has appointed Otto C. Wierum as temporary receiver of the business under a bond of \$2,000.

The business was started May 15, 1906. David Brinker was in the polishing business at 17 John St. Abraham Brinker was of the firm of Brinker Bros., manufacturing jewelers, 36 John St., who sold out in 1905.

The liabilities are placed at \$8,000 and assets are said to be about \$4,000.

Charles L. Greenhall, 320 Broadway, is the attorney for the petitioning creditors.

The silver service for the armored cruiser *Montana* is being exhibited in Huber Bros.' store, at Dillon, Mont.

Cameos = Scarabs = Carbuncles

Notwithstanding the difficulty generally experienced at present in supplying the sudden demand for these goods, we have succeeded, thanks to our firmly established connections with the stone centers of Europe, in making arrangements for the uninterrupted supply of them and are, therefore, fully prepared to fill all orders for these articles with the least delay.

CAMEOS

Onyx, Pink and Brown Shell, and Coral

SCARABS and CARBUNCLES

Red and Brown Sard, Bloodstone, Moss Agate, Green Agate, New Zealand and Chinese Jade, Amazonite, Tiger Eye, Coral - Japanese and Italian, and

TURQUOISE MATRIX

L. Heller & Son

Importers of Precious and Imitation Stones
68 NASSAU STREET, NEW YORK

PARIS

39 Rue de Chateaudun

PROVIDENCE

212 Union Street

IDAR

14 Hauptstrasse

BLACK OPALS

REMARKABLE :: IRIDESCENT :: BEAUTIFUL

Black Opal, a recent Australian discovery, is one of the most beautiful stones hitherto found.

With it many inimitable jewelry creations are possible that must appeal in a forceful manner to the trade.

These remarkable stones exhibit a wonderful play of brilliant colors, ranging from light to cobalt blue, with flashes of violet, from delicate shades of green to peacock green, and all shades of reds, merging into orange and yellow tints.

Black Opal is a worthy addition to the finest stock, and jewelers will find it a welcome "Trade Magnet."

We can furnish these stones in various sizes and shapes, and their full merits can only be appreciated by being seen.

We make a specialty of AUSTRALIAN and MEXICAN OPAL MATRIX.

BUY FROM THE CUTTERS

AMERICAN GEM & PEARL COMPANY

14 & 16 CHURCH STREET, NEW YORK

London, 16 Holborn Viaduct

Paris, 39 Rue de Chateaudun

FROM MINES TO MARKET

Megaphos

AN EXCELLENT

PRISM BINOCULAR



Power, 7 Diameters
Jointed Cross Bars

RETAILS AT \$30.00

Leaving a Good Profit

For Sale by all Jobbers

Sussfeld, Lorsch & Co.

Importers

37 Maiden Lane

NEW YORK

Maiden Lane and John St. Connected by Arcade in the New Silversmiths' Building Now Completed.

The completion of the 20-story Silversmiths' building, located at 15, 17 and 19 Maiden Lane and 18 and 22 John St., New York, in the center of the wholesale jewelry district of Manhattan, has proved a great event for the jewelry business, as it not only means an addition to the great structures which house the wholesale trade, but by reason of the arcade on the ground floor, the building affords a quick means of connection between the two great jewelry streets at their busiest part, and it is needless to say that the opening of this new street in the Lane proved a convenience of which the trade was not slow to take advantage.

The arcade is on the west side of the building running from 15 Maiden Lane to 18 John St. The importance of the arcade is even greater than it would have been a few years ago because of the subway station at John St. It truly fills "a long felt want" which has been talked of but never before realized. News and confectionery stands have already made their appearance in the arcade and others will follow. The passenger elevators and stairway to the building are approached through the arcade.

The location of the new building in the center of the block between Broadway and Nassau St. affords much added room for offices and the advantages offered have been quickly realized as shown by the large number of firms which have already contracted for space. On the ground floor on Maiden Lane is one large store, which will be occupied by the Gorham Co.

The building is of steel frame construction with limestone front for the lower stories, the central portion being of brick and the upper stories of terra cotta and brick. The frontage on Maiden Lane is 72 feet 7 inches and the depth through from Maiden Lane to John St. is 148 feet 8 inches in the east side and on the west 143 feet 5 inches. The westerly "L" running through to John St. is 12 stories high, while the easterly John St. "L" is only five stories, thus insuring plenty of air and light to all the offices. The wing at 18 John St., which is given over to the arcade, has a width of 25 feet.

Many expressions of pleasure have been called forth at the completion of so commodious and convenient a structure. Among the firms who are moving into the new building are: Thomas W. Adams & Co., Aikin-Lambert Co., Barrett, Nephews & Co., H. F. Barrows Co., R. Blackinton & Co., Bliss Bros.' Co., Block Bros., J. B. Bowden & Co., D. D. Brokaw, Bruhl Bros. & Henius, Estate of O. M. Draper, Wm. B. Durgin & Co., Elgin National Watch Co., Ford & Carpenter, Ira Goddard, the Gorham Co., W. S. Hicks' Sons, Himalaya Mining Co., International Silver Co., Jewelers Board of Trade, Jewelers' Protective Union, Jewelers' Safety Fund Society, Wm. B. Kerr Co., Mabie, Todd & Co., Maebert & Reiss, Marden & Kettlety Co., Charles Marx, M. A. Mead & Co., Queen City Silver Co., Chas. M. Robbins Co., the Silversmiths' Co., E. L. Spencer Co., Standard Button Co., L. Tannenbaum &

Co., Towle Mfg. Co., Union News Co., Watson, Newell & Co., Isaac H. Weinberg, Weiner, Garson & Naigles, Whiting Mfg. Co., Williams Bros. Mfg. Co., Charles F. Wood & Co.

Examination of Geo. H. Carpenter Continues at New York.

The examination of George H. Carpenter, with whom Maurice C. Dreshfield was associated in transactions by which \$182,549 worth of diamonds are alleged to have been obtained from R. A. Breidenbach, 51 Maiden Lane, New York, was called again last week before special master Peter B. Olney, at his offices, 68 William St.

Mr. Carpenter was placed on the stand and examined by Referee William Lesser. He testified that his place of business was at 17 E. 32d St., New York, and that the top floor of the building, which was occupied as an office by the Monarch fire extinguisher corporation, was furnished up as an apartment, and that he often spent the night there. He said that there were three rooms, but only one was furnished, and described the furnishings of the room, saying that there were besides the usual furnishings, several vases, paintings, etc. He stated that he had occupied the place as a sleeping apartment more or less, since 1905, and when questioned more closely relative to the vases, said that there was one large vase and several other smaller Vienna ware vases. He placed the value of the large vase at about \$160, and said that he bought it from a Japanese concern in New York, and estimated the total value of the vases at about \$700. Some of the vases, he said, were bought at an auction sale on Broadway. The receiver demanded that a bill for the goods be turned over to him. Mr. Carpenter testified that the vases had been in the apartment at 17 E. 32d St. since they were purchased.

The receiver started to examine the witness relative to the Monarch corporation, which was incorporated under the laws of the State of Connecticut, in 1906. Mr. Carpenter stated that he was the president and treasurer of the corporation at the time the petition in bankruptcy was filed against him. I. M. Dittenhoefer, attorney representing Mr. Carpenter, objected to testimony being taken relative to the Monarch corporation, on the ground that such testimony was immaterial.

The referee then questioned Carpenter relative to his meeting with Morris Dreshfield, and the testimony produced was to the effect that Mr. Carpenter met Dreshfield the first time on the last Monday in August, 1906, and that he was introduced by a Mr. Ticer. He stated that Mr. Ticer had been helping him to finance the Monarch corporation by a sale of stock. He was questioned relative to the stock holdings of the corporation and testified that in August, 1907, that he owned practically all of the stock of the Monarch concern. He testified that the second meeting with Dreshfield, at 17 E. 32d St., occurred on the Friday following the last Monday in August, and that he met him again on Monday, Sept. 3, at the Jewelers' Exchange, 170 Broadway, at which time a contract was submitted and signed. A second agreement was entered into about

Sept. 5, which became the final contract, the first one being cancelled. The referee then questioned Mr. Carpenter relative to the American Sparklets Co.'s bonds. An adjournment was taken at 12 o'clock noon until April 30.

Wm. Lesser, referee in bankruptcy, in speaking to a CIRCULAR-WEEKLY reporter relative to the case, stated that there was a large number of witnesses whom he is desirous of examining, and that he hoped that the matter could be rushed along. Sol Oppenheimer appeared for R. A. Breidenbach and Mr. Cohen represented Mr. Dreshfield.

H. N. Konrad, Kansas City, Mo., Killed in Collision Between His Automobile and a Car.

KANSAS CITY, Mo., April 22.—Herman N. Konrad, doing business as a retail jeweler at 810 Grand Ave., was instantly killed Monday night, April 19, in a collision between his automobile and a northbound Brooklyn Ave. car, at the crossing of 14th St. and Brooklyn Ave. In the auto with Mr. Konrad were his wife and Mrs. F. S. Stewart, a relative of his wife.

At the time of the accident they were proceeding west toward their homes, a few blocks away, and Mr. Konrad was running the auto, which was a surrey—a high-wheeled motor vehicle—at a pretty strong speed. When he became aware of the danger of a collision he tried to turn it aside, but the speed was too great to get it under control in time. The impact threw him against the side of the car with great force, and death resulted instantly. Mrs. Konrad and Mrs. Stewart were picked up unconscious and taken to the University hospital. It is very doubtful if either will recover. Mrs. Konrad remained unconscious for 48 hours, but is still delirious, while Mrs. Stewart has not yet recovered consciousness.

The physicians say both women may recover, but are by no means hopeful. No arrangements have yet been made looking to the continuance of Mr. Konrad's business, and will not be for several days.

Thieves Loot Cleveland Jewelry Store While Clerk Talks to Accomplish Who Drives Up in a Buggy.

CLEVELAND, O., April 25.—It appears that George L. Harding, a jeweler of 7120 Lorain Ave., was the victim, last week, of a very clever pair of expert "jewelry workers." An unknown man rented a horse and buggy from a west side livery, and with an accomplice drove up before Mr. Harding's store and called out his clerk, Chas. Rush. They engaged him in conversation for several minutes, with reference to prices, qualities etc., and drove off with the remark that they would return later.

Returning to the store, Rush found that confederates had rifled the stock of watches, rings and diamonds to the value of \$2,000.

Though the police were notified at once and detectives worked hard on the case, no trace has been found of the thieves and it is thought that they visited Cleveland especially to commit this robbery after having carefully prepared plans.

HELLO!

8870)
 8871 } Cortlandt
 8872)

CONNECTING ALL DEPARTMENTS OF THE

HIMALAYA MINING COMPANY

MINERS AND CUTTERS OF

PRECIOUS AND SEMI-PRECIOUS STONES

IN ALL SIZES AND SHAPES

15-17-19 MAIDEN LANE

NEW YORK

LONDON :: PARIS :: OBERSTEIN :: PROVIDENCE

ROUGH DEPARTMENT—Anything Cut to Order.

CUTTING WORKS—Repairing, Cutting and Polishing by Expert Men
 in this line.

ENGRAVING DEPARTMENT—Crests, Monograms and any kind of
 Intaglio or Cameo Work.

OFFICE—All Orders receive our Prompt Attention for any Goods
 ON MEMORANDUM.

West Virginia Retail Jewelers Hold Important Annual Convention at Clarksburg.

CLARKSBURG, W. Va., April 22.—The third annual convention of the West Virginia Retail Jewelers' Association was held here at the Hotel Waldo to-day. The following representative jewelers gathered together in the assembly room of the hotel at 2.30 P. M., when the very enthusiastic meeting was called to order by President T. A. Westmyer: C. A. Keefer, of G. W. Loar & Co., Grafton; W. L. Jones, Martinsburg; B. F. Robinson, Clarksburg; J. F. Krohme, Clarksburg; Lee Probst, Clarksburg; R. E. Gill, Clarksburg; C. A. Wernecke, St. Mary's; Henry Zilliken, Wellsburg; G. W. Berisford, Piedmont; A. C. Duerr, New Martinsville; G. C. Burrell, Weston; T. A. Westmyer, Wheeling; C. E. Baab, Parkersburg; A. C. Martin, Mannington.

After some preliminary remarks the minutes of the previous meeting were read and approved. The old executives were further complimented by being returned to office for another year, as follows: T. A. Westmyer, president; C. A. Wernecke, first vice-president; B. F. Robinson, second vice-president; C. E. Baab, secretary and treasurer.

An executive committee consisting of C. A. Keefer, W. L. Jones, Henry Zilliken, J. H. Grubb and Ed. Mittendorf was chosen, and the president further appointed a committee on membership consisting of J. F. Krohme, Henry Zilliken, G. W. Berisford, and a "committee on qualities" consisting of Lee Probst, A. C. Duerr and G. C. Burrell.

The regular business of the session was then taken up, and President Westmyer read a proposition from a journal published at Cincinnati that that paper be made the official organ of the West Virginia Association, and a motion to accept was carried. It was agreed that the next meeting be held at Elkins, W. Va., upon call of the executive committee, and that the president and the secretary would be the legislation committee until that time.

It was the sense of the meeting and very strongly urged by several present that delegates be sent to the National convention at Cincinnati in August. A letter from an Indiana dealer, suggesting that jewelers generally adopt a trade stamp similar to the printers' union label was discussed but laid on the table.

The pending gold-filled watch case legislation was gone over very carefully and the following resolution prevailed unanimously: "Resolved, That we, the West Virginia Retail Jewelers' Association, refuse to act upon or accept any stamping bill regulating the manufacture of filled cases unless the manufacturer is compelled to use a time guarantee in addition to the stamp of qualities of material."

After extending a hearty vote of thanks to the hotel management the meeting adjourned, subject to the call of the executive committee.

HERE AND THERE AT THE CONVENTION.

E. S. Fishback, of the Hamilton Watch Co., and D. G. Regan, representing the South Bend Watch Co. and Joseph Fahys Co., were welcome visitors.

All the Clarksburg jewelers turned up, joined the association and got better acquainted in a few hours than they would in 10 years by themselves.

What with Westmyer, Baab, Krohme, Zilliken, Duerr, etc., the Germans were in command and Wurzbarger was the order of the day.

John Krohme, as master of ceremonies and chief entertainer, made every fellow have a good time.

R. S. Dillon and C. N. Hancher, of Wheeling, were in town for a few hours with a large party of Wheeling retailers in a trade excursion through West Virginia.

Westmyer is a hustler—he left the dinner table to get two new members from Clarksburg and came back with the cash for their yearly dues.

Brownfield, of Fairmont, started over, but was delayed on the way.

A. C. Martin, of Mannington, misunderstood the date, but arrived in time to take part in the discussion of the pending stamping legislation.

Krohme's store was headquarters and John chief pilot about Clarksburg.

Better go to Elkins for the next meeting.

Death of David Jacobs.

CINCINNATI, O. April 23.—David Jacobs, of D. Jacobs & Co., one of the best known wholesale jewelers in this section, died at an early hour, Tuesday, April 21, as a result of an operation. He had been connected with the trade here 38 years.

Mr. Jacobs, who was 58 years old, came from Germany, his birthplace, to this city, when a young man, and opened a wholesale jewelry business on 5th St., where he remained some years, afterward going to the Palace Hotel building. From there he moved to 605 Race St., where he continued until about 10 years ago, when he moved to the company's present location.

Mr. Jacobs was a broad-minded, far-seeing man, planning his business in such a manner that at his death it might continue in the hands of his sons, whom he had instructed in business affairs and made partners in the concern, as they each in turn arrived at their 21st birthday. For the last four years, Mr. Jacobs had been an invalid, and about two years ago was compelled to cease active business, but came often to the store, which seemed to be a great source of enjoyment to him. Although the family and friends were not unprepared for the end, his death was a great shock and caused deep grief to all who knew him, as well as those who had benefited by his numberless good deeds and cheery words.

Outside of his business, deceased was prominent in social and financial circles, and was connected with the Royal Arcanum, the Jewelers' League and the I. O. B. B. The funeral was held to-day at his late residence, Albany Ave., Avondale.

Mr. Jacobs is survived by a widow, one daughter, and three sons, Julius, Arthur and Edwin, who will continue the business as heretofore.

Jewelers' Gold Bars Withdrawn and Exchanged at New York.

Week Ended April 25, 1908.

The U. S. Assay Office reports:	
Gold bars exchanged for gold coin.....	\$5,761,923.53
Gold bars paid depositors.....	38,884.19
Total	\$5,800,807.72
Of this the gold bars exchanged for gold coin are reported as follows:	
April 20.....	\$563,397.46
" 21.....	35,590.07
" 22.....	5,085,200.96
" 23.....	51,871.29
" 24.....	5,310.82
" 25.....	20,552.93
Total	\$5,761,923.53

Jewelry, Clocks, Watches, Silverware and Kindred Lines Exported from New York.

WASHINGTON, D. C., April 22.—The following are the exports of jewelry, silverware, optical goods, clocks, watches and kindred lines from the Port of New York for the week just ended:

Auckland: 1 case watches, \$120; 193 cases clocks, \$2,867; 31 cases plated ware, \$552; 105 cases clocks, \$2,064; 1 case watches, \$122.
Basle: 1 case jewelry, \$100.
Bremen: 6 cases watches, \$5,005; 2 cases jewelry, \$650; 2 cases plated ware, \$222.
Buenos Ayres: 255 cases clocks, \$4,817; 1 case watches, \$500.
Calcutta: 6 cases plated ware, \$857; 39 cases clocks, \$846.
Cape Town: 1 case optical goods, \$132; 3 cases watches, \$2,804.
Colon: 9 cases clocks, \$420; 3 cases jewelry, \$100; 2 cases plated ware, \$462.
Genoa: 1 case jewelry, \$376.
Guayaquil: 2 cases jewelry, \$596.
Hamburg: 5 cases optical goods, \$927.
Havre: 2 cases scopes and views, \$155; 4 cases plated ware, \$2,500; 1 case jewelry, \$105.
Havana: 2 cases clocks, \$125.
Hobart: 1 case watches, \$106.
Kingston: 1 case watches, \$120.
Liverpool: 1 case silverware, \$195; 2 cases jewelry, \$315; 2 cases jewelry, \$200; 72 cases clocks, \$953.
London: 3 cases optical goods, \$191; 1 case plated ware, \$410; 5 cases watches, \$613; 11 cases optical goods, \$5,354; 1 case jewelry, \$125; 1 case jewelry, \$250.
Melbourne: 19 cases clocks, \$200; 3 cases optical goods, \$389; 144 cases clocks, \$2,125; 26 cases plated ware, \$1,579; 2 cases jewelry, \$394.
Montevideo: 1 case optical goods, \$328; 13 cases clocks, \$696.
Oporto: 51 cases clocks, \$535; 1 case plated ware, \$618.
Port Limon: 3 cases plated ware, \$164.
Rangoon: 1 case watches, \$150; 4 cases plated ware, \$289; 4 cases watches, \$570; 36 cases clocks, \$432.
Rio de Janeiro: 9 cases clocks, \$155.
St. Johns: 28 cases clocks, \$342; 5 cases jewelry, \$145.
Southampton: 51 cases clocks, \$1,254; 1 case optical goods, \$226; 13 cases watches, \$2,267; 8 cases watches, \$1,170; 27 cases clocks, \$302.
Smyrna: 12 cases clocks, \$113.
Vera Cruz: 2 cases plated ware, \$285.
Zurich: 1 case watches, \$156.

Importations at the Port of New York.

<i>Weeks Ended April 20, 1907, and April 18, 1908.</i>		
China, Glass and Earthen Ware:	1907.	1908.
China	\$71,228	\$52,668
Earthen ware	12,347	10,304
Glass ware	25,613	20,476
Optical glass	4,894	6,095
Instruments:		
Musical	17,683	11,578
Optical	9,757	6,455
Philosophical	1,464	2,972
Jewelry, etc.:		
Jewelry	17,161	5,664
Precious stones	469,109	93,401
Watches	38,094	17,193
Metals, etc.:		
Bronzes	760	5,539
Cutlery	46,523	22,709
Dutch metal	1,677	2,907
Platina	107,122	16,548
Plated ware		
Silverware	2,510	606
Miscellaneous:		
Alabaster ornaments	11	3
Amber	10,157	11,016
Beads	7,598	2,141
Clocks	5,777	1,671
Fancy goods	7,935	5,696
Fans	4,329	1,117
Ivory	18,103	
Ivory, manufactures of..	390	465
Marble, manufactures of.	20,683	28,770
Statuary	5,985	4,424

The business of the late George S. Goldstone, Bennett, Ia., will be continued by Mrs. George S. Goldstone.

Chester Billings & Son

1840

Successors to
Kandel, Barmore & Billings

1908

Importers of Diamonds
Other Precious Stones, and
Pearls, Diamond Jewelry

1840, Kandel & Barmore; 1866, Kandel, Barmore & Co.; 1880, Kandel, Barmore & Billings; 1897, Chester Billings & Son

New York, 58 Nassau Street, 29 Maiden Lane
London: 22 Holborn Viaduct, E. C. Paris: 53 Rue de Chateaubum
Amsterdam: 2 Tulp Straat

GEORGE H. HODENPYL.

WALTER N. WALKER.

HODENPYL & WALKER

IMPORTERS OF

DIAMONDS

OTHER PRECIOUS STONES
AND PEARLSMANUFACTURERS OF
FINE DIAMOND JEWELRY

373 FIFTH AVENUE,

NEW YORK

Corner 35th Street

Telephone, 5093 Madison Square

EISENMANN BROS.

IMPORTERS OF

Pearls and Precious Stones

452 Fifth Avenue, New York
cor. 40th St., Knox Building

3 Rue St. Georges, Paris.

"There is Nothing in the Art that we cannot do."

Special Attention

GIVEN TO OUT OF TOWN ORDERS

The International Gem Co., Inc.

12-16 JOHN ST., NEW YORK

TELEPHONE 1241 CORTLAND

Lapidaries and Importers of Precious Stones

SPECIALISTS IN REPAIRING AND REPOLISHING RARE AND VALUABLE GEMS
DRILLING—ENGRAVING—SLITTING

H. F. BARROWS COMPANY

MAKERS OF

Rolled Plated Chains

FACTORY:

NORTH ATTLEBORO, MASS.



AFTER MAY 1st

Our New York Office will
be Room 1705-17th floor
SILVERSMITHS BUILDING
15-17-19 Maiden Lane.

TELEPHONE CONNECTION

George A. Bromhall Taken to New Haven for Trial.

Man Known as the "Automobile Clock Thief" Has Victims in Many Cities—Arrest Brought About by Publicity Given to His Methods.

CINCINNATI, O., April 23.—George A. Bromhall, alias Powell, and many other names, arrested here by the police April 18 as the man known as the "automobile clock diamond thief," and held until the arrival of the New Haven (Conn.) detectives, to extradite him upon the charge of S. Silverthau, of that place, has confessed to the thefts charged against him and willingly left to-day with the detectives for New Haven.

As noted last week, the arrest was due to the careful study of THE CIRCULAR-WEEKLY by B. Von Wahlde, a watchmaker. He had read of Bromhall swindling S. Silverthau & Sons, 790 Chapel St., New Haven, Conn., out of \$900 worth of diamonds by using his automobile clock trick to get acquainted. Also that he was supposed to have robbed J. D. Kingsberg, Springfield, Mass., Jan. 8, of two rings valued at \$400, and L. Simon, in Brooklyn, of rings valued at \$500, as well as the other thefts done in Troy, N. Y., and other places. So when Bromhall appeared at Herman Lange's store, Vine St., where Mr. Von Wahlde is engaged as watch maker, and presented his automobile clock, Von Wahlde thought he recognized the man described in THE CIRCULAR-WEEKLY, and also the imperfect little finger spoken of in the account. The name on the automobile clock practically made identification certain.

Mr. Lange wasted no time in telegraphing Mr. Silverthau, and the latter replied by coming on to this city, reaching here April 17. With two detectives he went to a place near the store, as Bromhall was expected to call that day. The officers had not waited long when the swindler came. Silverthau instantly recognized the man as the thief who had robbed him and pointed him out to the police, who laid hold of him.

The prisoner had been here over a week, and had a confederate with him, who disappeared immediately after the arrest. Bromhall refused to tell where he was stopping, and gave his name as Charles A. Powell, a railroad switchman instead of an actor, as was his former custom. He said New York was his residence, and on the way to the police station threw into the street a bundle of letters which were later picked up and found to be from a friend in Long Island, who said he had heard "the actor had been at work again."

Bromhall was locked up charged with being a fugitive from justice, and Chief of Police Henry D. Cowles, of New Haven, Conn., was immediately notified to secure requisition papers and send an officer after Bromhall.

When arrested the prisoner was wearing a handsome diamond stick pin which Mr. Silverthau thinks was one of the diamonds stolen from him, but it had been reset. It was later learned that Bromhall had selected a \$300 diamond at William Preuer's store, 7th St., which he wanted reset, and was to have called to see it on the afternoon of his arrest.

In another package of letters found the police recovered six pawn tickets for diamonds the prisoner had pledged in New York. On some of the rings he got \$125, \$100, \$70, and \$27. There was also a pawn ticket for a revolver and a speedometer which he had pawned in New Haven, Conn. The names of the pawnbrokers in New York given are Bernstein Bros., L. Jacobs, Goldstone Bros., and H. J. Daveson.

COLUMBUS, O., April 22.—Chief of Detectives Dunn and Detective Donnelly, of New Haven, Conn., accompanied by F. Silverthau, a New Haven jeweler, were in Columbus to-day, to have honored by Gov. Harris, requisition papers for the return to Connecticut of Charles A. Powell, or Geo. H. Bromhall, who is charged with being a diamond thief. It is charged that he stole \$900 worth of diamonds from Mr. Silverthau. Bromhall-Powell's method it is said was to have an automobile clock which he would take to a jeweler for repairs. He would make several calls while the clock was in the shop and get acquainted with the jeweler, then would make arrangements to sell diamonds on commission and in this way get possession of them.

NEW HAVEN, Conn., April 26.—George H. Bromhall, the thief who cleverly robbed S. Silverthau & Sons, 790 Chapel St., six weeks ago, is at last safely under lock and key at Police Headquarters here, having arrived last night from Cincinnati, handcuffed to Detective Donnelly. Capt. Dunn and A. Silverthau, who went on to Cincinnati to bring the man here, arrived with him.

When questioned at Police Headquarters the prisoner gave his name as George A. Bromhall, New York, and he was locked up to await examination on the charge against him. It is deeply regretted that Bromhall's accomplice was not also captured in Cincinnati, but still there is great satisfaction in the arrest, because Bromhall was undoubtedly the moving spirit.

Bromhall's scheme was to take an automobile clock to a jewelry house for repairs and get acquainted with the house in this way. When he had disarmed suspicion he would look at diamond jewelry, and get away with it in any way possible.

TROY, N. Y., April 22.—The so-called "automobile clock" thief who was arrested in Cincinnati is believed to be the man who, on Jan. 18, stole from the store of Paul Bros., at 52 River St., two diamond rings, valued at \$173. At that time the man, who said he was an actor, left an automobile clock to be repaired, and when he came back to get it asked to look at some diamond rings. As soon as he was permitted to examine two of them he bolted from the door and made his escape.

SPRINGFIELD, Mass., April 22.—The local detective bureau was pleased when the news

that Bromhall, or Charles A. Powell, had been arrested at Cincinnati, as it is believed that he is undoubtedly the man who stole two diamond rings, valued at \$300, from the store of J. D. Kingsberg, in this city. The man went to the Kingsberg store with a Chelsea clock, which he left to be cleaned, and after paying many visits to the store and getting acquainted with the clerk he asked to look at some diamonds. While he was comparing some rings under a magnifying glass he suddenly threw down the glass, ran out of the door and made his escape. The police have been looking for him ever since.

BROOKLYN, N. Y., April 22.—Captain Kuhna, of the Brooklyn detective department, yesterday talked with the Chief of Detectives of Cincinnati on the question of getting hold of George A. Bromhall, arrested in the latter city, charged with swindling jewelers. When he learned that the man was to be extradited to New Haven for trial he stopped his inquiries. Should the New Haven charge not be pressed, however, an attempt will be made to bring him to Brooklyn to stand trial on the charge of stealing about \$500 worth of diamonds from L. Simon, of this borough.

UTICA, N. Y., April 23.—Jewelers in this section of New York State are interested in the capture of a clever jewelry thief by the Cincinnati, O., police. He is George A. Hardy, or George W. Bromhall. It is believed that he is the thief who swindled about half a dozen jewelers in up-State cities during the Winter. His operations were extremely bold. In one or two stores he took valuable jewelry and escaped in the street crowds.

Shipping Clerk Charged with Stealing and Destroying Yachting Trophy and Selling the Silver.

BOSTON, Mass., April 25.—Alexander B. Mills, assistant shipping clerk for Shreve, Crump & Low Co., was arraigned to-day in the District Court and held in \$500 bonds for the Grand Jury. He is charged with thefts from his employers amounting to about \$500 in value, and is said to have confessed his guilt.

Discovery of the larcenies was brought about by the disappearance of a yachting trophy which had been placed in storage in the custody of the concern. Detectives from police headquarters located pieces of the cup, which had been cut up by the culprit, in pawnbrokers' hands, and the description of the man who had pawned them tallied with that of Mills.

The cup was the property of Robert W. Emmons, the former Harvard football player, whose yacht, the *Humma*, won it in a New York Yacht Club race in August, 1906, and was valued at upward of \$100, aside from the sentimental value attached to it as a prize.

Curiously enough, although Mills was well recommended when he entered the employ of the company last December, it has been learned by Major Shreve since his arrest that he has a previous court record, knowledge of which was kept from the Shreve, Crump & Low Co. when he was engaged. Mills is married and has a family. He is 34 years old.

ADDISON W. WOODHULL, President.
FRANK K. HUFF, Vice-President.

GILBERT T. WOODHULL, Treasurer.
WILLIAM J. McQUILLIN, Secretary.

MOUNT & WOODHULL,

IMPORTERS OF

DIAMONDS,
OTHER PRECIOUS STONES,
PEARLS, ETC.

MAKERS OF

FINE
DIAMOND
JEWELRY.

26 Maiden Lane,
(Southwest Corner Nassau Street)

NEW YORK

EMERALDS, DIAMONDS
AND PEARLS

CABLE ADDRESS:
MILBAGG

BAGG & CO.
Successors to BAGG, PERINE & CO.
IMPORTERS

452 FIFTH AVENUE, at 40th Street
NEW YORK

TELEPHONE
NUMBERS:
917-918 BRYANT

RUBIES AND
SAPPHIRES

Pearl Necklaces and Collarettes.

Mounted
Diamond
Jewelry

of every
description.



Largest
assortment
of all kinds of
very fine, fancy
and rare gems,
including Pearls,
Diamonds, Rubies,
Emeralds and Sapphires.

Particularly Fancy
Colored and Fancy
Shaped Diamonds.

182 & 184 BROADWAY
NEW YORK

THE Mercantile National Bank

195 BROADWAY
NEW YORK

Capital and Surplus
\$5,000,000

WILLIS G. NASH, President

MILES M. O'BRIEN, - Vice-Pres.
WM. SKINNER, - - Vice-Pres.
WILLIAM H. TAYLOR, Vice-Pres.

EMIL KLEIN, Cashier.

DIRECTORS

Wm. F. Carlton Robert C. Clowry
William Nelson Cromwell

L. H. Cutter Edwin Gould
Harold A. Hatch

Edward T. Jeffery
William H. Laws
Willis G. Nash
Benjamin Nicoll
Miles M. O'Brien
Charles E. Perkins

Dick S. Ramsay William Skinner
E. D. Street

William H. Taylor E. J. Trussell
Warner Van Norden

Strictly a Commercial Bank

Accounts Solicited

Gems and Precious Stones

Their Characteristics, Localities of Production
Tests and Some Current Literature

Cloth, Postpaid, \$1.00

Published by
THE JEWELERS' CIRCULAR PUB. CO.
11 John Street, New York

Head of the London Diamond Syndicate Tells of the Stability of the Diamond Market and Predicts a Quick Resumption of Demand for Gems.

L. Abrahams, of L. & A. Abrahams, London, head of the Diamond Syndicate, who as noted in the last issue of THE CIRCULAR-WEEKLY has been spending a short time in New York, sails for Europe to-day, and though Mr. Abrahams came to this country purely on a personal matter to see his daughter his visit has not been without beneficial effect to the diamond trade, inasmuch as he was able to meet and talk with the principal diamond importers and cutters of the country, and in addition consented to be interviewed by one of the largest daily papers of New York City, this interview being copied broadcast throughout the United States.

In the interview which he gave out Mr. Abrahams stated that while it was true that the financial stringency of America had caused the demand for diamonds to be materially reduced, that this had followed a few years (particularly 1905 and 1906) when the demand for diamonds had increased beyond all precedent, these being the years of great prosperity here. Continuing he said:

"The De Beers Consolidated Mines, Ltd., the Premier Diamond Mining Co., of the Transvaal, and the Jagersfontein Diamond Mining Co., which three corporations jointly supply about 98 per cent. of the whole output, were all kept working to their full capacity. The demand, without a doubt, greatly exceeded the supply at that time. We found no difficulty in selling at market rates every carat that could be mined, and we could have sold more had more been produced.

"But the recent American crisis in finance has now altered things materially. From having been the largest of customers you Americans are now buying practically no diamonds at all. The financial stringency has been of a kind that has affected chiefly the resources of persons who in ordinary normal conditions can afford to indulge in such luxuries as precious stones. In consequence of these conditions the De Beers mines within the last two or three months have been decreasing their output more than one-half.

"Owing to this marked falling off in the demand there has been some nervousness in the diamond buying world lest there would follow a cheapening of prices. Now, I dislike anything that may seem to smack of advertising. We have never advertised our business. We do not commonly rush into print. Ours is a business which goes by itself. But if any diamond buyers and diamond owners have been misled into the belief that under present conditions prices are to come down he has a very erroneous idea. In reply to numerous inquiries the De Beers company, the Premier company, of the Transvaal, and the Syndicate itself have all issued official statements announcing unequivocally their purpose to maintain prices at their normal levels. As the concerns named substantially control the world's output it seems to me this assur-

ance ought to be accepted as conclusive and it should allay all nervousness on the subject.

"Despite your recent depression, I am convinced that there would be some business here now were it not for the more or less widespread feeling of mistrust in regard to the authenticity of these assurances. Overproduction has never been the policy of any of the companies named, and there will be no overproduction now. It will probably not be necessary to shut down the mines, as their output can be readily curtailed without resorting to so extreme a measure.

"Owing to labor conditions in Africa and to other considerations, it probably would be neither expedient nor economic to close down entirely, but, so far as concerns the ultimate effect upon the market, it is immaterial whether the rough diamonds are permitted for a time to lie in the ground or are allowed to accumulate in the coffers of the companies and the syndicates.

"There is no doubt of the ability of the Syndicate to control the situation. The Syndicate's contracts with the Premier Mining Co. are about to expire, and that company will hereafter market its own product, but it has given every possible assurance that it will co-operate in the maintenance of prices. It would be contrary to their own interests to do anything else, and I am perfectly satisfied with their attitude.

"Since a recent extension of the capacity of its plant the Premier is now in position probably to mine about 25 to 30 per cent. of the total value of the diamond output, the De Beers and the Jagersfontein mines producing most of the remainder. The last named, though an independent mine, is operated harmoniously with the De Beers company, the largest shareholders in both interests being identical.

"In my opinion it will not long be necessary to restrict the normal output of the mines. I believe the period of financial depression is not destined to be of long duration in America or anywhere else, and that within a comparatively brief time business will resume its natural equilibrium and America will move on in its destined career of prosperity."

In talking with the editor of THE CIRCULAR-WEEKLY Monday Mr. Abrahams stated that there was no foundation at all for any of the silly reports which came to this country, for at no time had those who controlled the diamond mines or the Syndicate for a minute considered there was any question about prices being maintained under all circumstances. In fact, said he, the present prices of diamonds and those of the prices of diamonds for years past had been much below the prices warranted by the demand for those gems, and the members of the Syndicate had never had anything like enough rough to supply the calls made upon them. The price of diamonds cannot be affected by a temporary increase or decrease in sales, but is

based on the world-wide demand which will always exist for this most beautiful of gems. The situation is well understood by the interests that control the mines, and the idea of forcing a demand by any reduction in prices has never been considered.

He said that the proportion of the stones taken by the United States, to the entire amount mined, had been increasing of recent years, and consequently the drop in the demand in this market had a very material effect upon the entire amount of diamonds sold; but, he said, this condition was but temporary, and while it might have some effect upon the prices of the *shares* of the mining stock it would have none on the prices of diamonds, nor could the stock quotations affect prices in any way.

In speaking of the diamond failures throughout the world, generally, in the past 15 years, Mr. Abrahams called attention to the fact that most of the failures in this trade that had come to his attention had been caused by outside speculations of the bankrupt more than by any condition that had existed in the diamond trade and had never been caused by the prices at which diamonds were sold.

Excellent Work in Jewelry Designs Done by Class of Attleboro Y. M. C. A.

ATTLEBORO, Mass., April 27.—A class in jewelry design, run by the Young Men's Christian Association for ambitious young men in the factories, concluded its season's work last week and gave a public exhibition which evoked surprised and favorable comment. The class was in charge of J. H. Harmstone, head designer in a local factory, and long skilled both at that trade and as an instructor. The aim was not only to produce artistic designs, but ones that were eminently practical—that could be worked out in metal, stones and emerald at a cost low enough to be marketable, and free from such eccentricities as would relegate them to a freak class.

The result was a collection of designs that would do credit to the art department of the biggest jewelry concern, some of which will appear as samples on the road in the near future, it is said.

Crayon designs were shown by Carl M. Wendelstein, C. Dudemaine, F. J. Armstrong and Fred Hoyle. Pencil work was done by Oscar A. Fisher, B. Reddin, W. H. Creland, Carl Kiel, C. Dudemaine, Fred Hoyle, Frank E. Holland, F. G. Armstrong, William T. Roberts, Harry Simms, Sven Pilblad, F. Archambault, F. H. Moulton and G. A. Guyot. Clever work in clay modeling was done by several of the above named. Some of the designs on paper were artistically colored.

The work won more than passing notice from men in the trade.

The general store of F. E. Sykes, Beech Creek, Pa., was broken into, about a week ago, by thieves who escaped with stock valued at about \$500.

F. A. Montgomery, at one time located in the retail jewelry business at Tonopah, Nev., and who went away for a period of four years, has returned to his old location. During his absence he conducted a retail jewelry establishment at Vancouver, B. C., and later went to the Yukon territory.

W^M S. HEDGES & CO.,

IMPORTERS AND CUTTERS OF

DIAMONDS.

Precious Stones and Pearls.

170 Broadway, Corner Maiden Lane, New York.

27 Holborn Viaduct, London.

JAGERSFONTEIN

and other Gem Diamonds

SAUNDERS, MEURER & CO.

65 Nassau Street

NEW YORK

F. A. JEANNE

Rubies and Emeralds

5 Square de l'Opera

PARIS, FRANCE

Cable Address

"GEMFINDER"

Western Union Code

STERN BROS. & CO.,

CUTTERS OF

DIAMONDS,

CUTTING WORKS:



138-142 West 14th St., N. Y.

68 Nassau St.,

NEW YORK.

CHICAGO,
103 State Street.

LONDON,
29 Ely Place.

-  1. Snap complete.
-  2. Outside of snap.
-  3. Inside of snap.

**The E. P. H. Patent
NON-PULL-OUT
Neck Chain Snap**

*is a patented snap that insures
the wearer against loss of*

CHAIN or CHARM
for it positively will not pull out

Made in 10 and 14 Karat Gold and
in Gold Filled.

*Can be had of the following Whole-
sale Selling Agents:*

- Messrs. W. Green & Co.,
81 Nassau St., New York
- | | |
|------------------------------|-------------------|
| M. Sickles & Sons, | Philadelphia |
| E. A. Cowan & Co., | Boston |
| E. & J. Swigart, | Cincinnati |
| Swartchild & Co., | Chicago |
| Nordman Brothers, | San Francisco |
| Leonard Krower, | New Orleans |
| A. Walker Co., | Providence, R. I. |
| Bauman-Massa Jewelry Co., | St. Louis |
| H. S. Meiskey Co., | Lancaster, Pa. |
| The Edw. Lehman Jewelry Co., | Denver, Col. |

PRICES.

- 14 Karat—Small, \$7 per doz. net
- Large, \$7.50 per doz. net
- 10 Karat—Small, \$6 per doz. net
- Large, \$6.50 per doz. net
- Gold Filled—Small, \$2 per doz. net
- Large, \$2.25 per doz. net

**THE GREAT AMERICAN
JEWELRY CATALOG**

Is a publication of real practical value; it truthfully illustrates those lines of merchandise; best adapted to the needs of the *Jewelry Trade*; its reliability is unquestionable.

SAFETY

With implicit confidence you can use it when ordering goods; it insures you against deception; remember, for every dollar's worth of merchandise you buy you are obtaining positive, intrinsic value.

Write for this catalog; it means much to you.

THE OSKAMP-NOLTING CO.

Mammoth Wholesale Jewelers
411-413-415-417 Elm St., CINCINNATI, OHIO

RUDOLPH NOEL

PHILIP NOEL

RUDOLPH NOEL & CO.

IMPORTERS AND CUTTERS OF DIAMONDS

2 Tulp Straat, AMSTERDAM

37-39 Maiden Lane, NEW YORK

Nest No. 1 of the Noble Order of Ku-Kus Instituted by Jewelers and Opticians at Piqua, O.

PIQUA, O., April 24.—At a banquet given last night at the Hotel Plaza, the initiatory degree was given to a large number of applicants by Nest No. 1, of the Noble order of Ku-Kus. A number of candidates in surrounding cities were present and the affair was a success in every way. The banquet hall was artistically decorated for the occasion, the guests numbering over 60, being seated at tables holding 17 each, and the whole affair being presided over by A. L. Thoma, who organized and founded the order.

After an excellent menu had been enjoyed, a number of toasts were responded to, Mr. Thoma acting as toastmaster. The first speaker was Mayor J. Clare Hughes, who delivered an address of welcome, in the course of which he thanked Mr. Thoma for the honor which he had brought to the city by organizing the lodge here, after which he assured all present that he extended to them the keys to the city. Another address was delivered by F. B. Barr, of Lancaster, O., on the subject, "Business Recognizers Brotherhood," while other in-

Walter C. Reed, all of Dayton; Frank D. Ausman, St. Marys, O.; Edw. L. Jones, Sandusky, O.; O. B. Maxvin, Findlay, O.; Geo. F. Ireland, West Milton, O.; M. B. Ullery, Covington, O.; John A. Walsh, Delphos, O.; Geo. A. Bain, Meriden, Conn.; W. E. Moulton, Plain City, O.; Chas. H. Osmon, Rockford, Ill.; F. P. Barr, Lancaster, O.; J. E. Bucher, Urbana, O.; W. D. Harmon, Troy, O.; Holmes S. Kimball, New York; Fred C. Lockett, Greenville, O.; J. H. Max, Sidney, O.; Geo. M. Tripp, Greenville, O.

Optometry Law Passed by Both Houses of New York Legislature.

ALBANY, N. Y., April 22.—After a long, strong and strenuous fight the Legislature has passed the Optometry Bill, and it has now gone to Governor Hughes for his approval. The bill, which was passed by the Senate about two weeks ago, came up for final vote in the Assembly yesterday, and after the vote passed the body stood 83 to 47, 76 votes being necessary for passage.

It will be remembered that the bill passed both houses of the Legislature last year and was vetoed by the Governor on a technical objection relating to the appointment of the

Carter Ave., Norwood, Thursday, after which the remains were cremated in the Clifton Crematory.

Members of the Oklahoma Retail Jewelers' Association Hold Enjoyable Convention.

OKLAHOMA CITY, Okla., April 22.—As predicted in the last issue of THE CIRCULAR-WEEKLY, the annual convention of the Oklahoma Association of Retail Jewelers has proven to be a success in every way. Fully 100 jewelers and opticians have been in attendance at the second annual meeting during the two days' session ending to-day.

After the meeting convened yesterday morning, 35 new applicants were admitted, and H. A. Bump delivered the address as announced, on "A Few Business Pointers." This and the address of the President, Joseph Mazer on "What the Association Has Done in the Past," were received with applause. The general discussion in regard to the proposed bill abolishing the guarantees on haled watch cases, resulted in the appointment of a committee composed of J. Watkins, Okmulgee; C. O. Barnhill, El Reno; and W. C. Pfaffle, Enid, to report upon the matter, and the report of this committee which was received to-day means that the association will indorse the measure.

Mr. Higgenbothom's lecture on "The Errors of Escapement and How to Correct Them," excited a great deal of interest.

To-day the important work of the session was the election of officers for the ensuing years, and the selection of McAlester as the place for the next convention, which will be held in April, 1909.

The officers selected were: Joseph Mazer, McAlester, president; H. A. Bump, Oklahoma City, vice-president; A. Y. Boswell, Tulsa, treasurer, and F. C. Boasen, Oklahoma City, secretary. The average attendance at the two days' session was fully 100.

A resolution was adopted direct to the manufacturers, insisting that they enforce the minimum selling price upon all goods, which means that a uniform profit of sales will obtain throughout on certain and similarly stamped articles. The convention also suggested that a law be passed requiring that all jewelry of 10 karats or under be stamped.

A banquet was given in the Auditorium last night at which toasts were made and music selections given. The room was appropriately decorated. Because of the inability to charter street cars, the trolley ride scheduled for last evening was abandoned.

There is no specially prepared programme for the opticians' proceedings. Demonstrations and discussions will occupy the first day, and during the second officers will be elected and a meeting place for next year agreed upon. The same attendance at the jewelers' assembly is anticipated. The present officers are: A. W. Boswell, Tulsa, president; W. K. Grady, Stillwater, first vice-president; H. S. Ellison, Hobart, second vice-president; J. C. Eisfelder, Chickasha, treasurer; C. O. Lynch, Chandler, Stillwater; Jos. Mazer, McAlester, chairman; W. A. Wright, Shawnee, and R. C. Everts, Weatherford, executive committee.



JEWELERS AND OPTICIANS AT THE INSTITUTION OF NEST NO. 1, NOBLE ORDER OF KU-KUS.

teresting speeches were made by O. C. Lightner, Cincinnati; J. E. Eberhardt, Dayton, and others, while the enjoyment of the evening was increased by the excellent vocal selections rendered by the Dayton Male Quartet.

As previously announced in THE CIRCULAR-WEEKLY, the Noble Order of Ku-Kus is an organization of jewelers and opticians, essentially for pleasure and amusement, and it is expected that it will in the future be responsible for the fun which the jewelers and opticians will have at the annual convention of their National organization. The charter members of the Nest No. 1, just instituted, include: A. L. Thoma, Albin Thoma, A. L. Richey, E. C. Scott, Henry Sills, Leo Thoma, Perry M. Wolford, H. L. Greenbank, Fred Thoma, Jacob Wendel, Emmett P. Brush, George Haendel, and Joseph Thoma, all of Piqua; Otto C. Lightner, A. F. Thoma, Anton J. Thoma, Jerome A. Thoma, Carl A. Thoma, Jacob Dorst, Arno A. Dorst, A. J. Augustin, S. Bacharach, and Albert Stritmatter, all of Cincinnati; J. B. White, C. O. Haines, Fred R. Counts, E. M. Parks, H. E. White, Chas. L. Marshall, E. E. Marshall, F. T. Prosser, H. Clinton Green, John G. Gayman, Clyde S. Reed, W. E. Boulon, R. N. Whitford, L. W. Lewis, E. S. Albaugh, all of Columbus; J. C. Eberhardt, Perle L. Sagebiel, Geo. F. Merry,

examiners, but as this objection has been met in the new bill by drawing it in such a way that the Board of Regents have full control, it is generally expected that the measure will meet with Governor Hughes' approval and become a law at an early date.

Death of Julius Schaeppi.

CINCINNATI, O., April 25.—Julius Schaeppi, the oldest watchmaker in Cincinnati, and said to be the best in the State, died, Monday, April 20, from the effects of an operation for appendicitis.

Mr. Schaeppi was born in Jurich, Switzerland, where he learned watchmaking, and came to this country when about 18 years old. He first conducted a watchmaker's school with the old firm of Bowman & Swigart, and about 18 years ago he started as a watchmaker, having quarters with Joseph Mehmert, where he was located at the time of his death.

Mr. Schaeppi was very much devoted to his work, of which he was a thorough master. He was highly respected by all who knew him, and his death is much regretted throughout the trade. In lodge circles he was identified with the Pioneers, the National Union, and a Swiss Society.

Deceased is survived by a widow and four sons, one of which is Albert Schaeppi, a wholesale jeweler of Minneapolis, Minn. The funeral took place at his late residence,

Goodfriend Bros.

Importers of

Pearls and
Precious Stones

CAMEOS

9-11-13 Maiden Lane
NEW YORK

PARIS
10 Rue Cadet

PROVIDENCE
212 Union Street

DIAMONDS TRY US ON *Lissauer & Company* IMPORTERS
52-54 MAIDEN LANE, NEW YORK

A. ROSEMAN, 9-11-13 Maiden Lane, New York
IMPORTER OF **DIAMONDS** *Established 1872*
HEADQUARTERS FOR **AMERICAN WATCHES**
Maker of Diamond Jewelry *TRADE-MARK.*

Tel. 4457 } Cort. **JOHN M. RICHARD** 2 MAIDEN LANE
4458 } Room 302, NEW YORK
American Pearls and Baroques
MATCHED PAIRS FOR EARRINGS The Largest and Finest Assortment in the Market, Mounted and Unmounted.



THE LINE THAT SELLS, LEATHER FOBs

WITH EMBLEMS OF ANY SOCIETY,
Black or Tan Leather.
SPECIAL GRADE, with extra quality Gold-plated Emblems, \$3.33 dozen.
REGULAR GRADE, with regular quality Gold-plated Emblems, \$2.00 dozen.
LESS 10% FOR CASH,
On Single Cards or Half-dozen on Card.
Send your Order To-day.

THE CHAS. S. PURDY CO.
SOCIETY EMBLEMS
290 Westminister St. Providence, R. I.

WANTED WATCHMAKERS everywhere to know about
URICH Perfect Fitting CASE SCREW WASHER
Will hold movements securely in their case, even when shoulder is worn away. Fits perfectly under head of screw, and is almost invisible. Prices:
Single Dozen, - - - - 15c
4 Doz. Package, assorted, - 50c
Gross, - - - - - \$1.50 Pat. app. for



For sale at all Jobbing and Material Houses.
S. URICH, P. O. Box 1942, New York City
Gems and Precious Stones
Cloth, Postpaid, \$1.00. Published by the Jewelers' Circular Pub. Co., 11 John St., New York.

Receiver of Chas. F. Wood & Co. to Accept No Fees—Bankrupts Make Offer of Settlement and Incorporate a New Company.

No adjudication in the bankruptcy proceedings brought by creditors against Chas. F. Wood & Co., diamond importers at 1 Maiden Lane, had been made up to the time THE CIRCULAR-WEEKLY went to press yesterday, the matter having been postponed by the United States District Court several times. This was in part due, it is stated, to the fact that the concern is endeavoring to obtain a settlement with the creditors on a basis of 40 per cent., 15 per cent. in indorsed notes and 25 per cent. in undorsed notes, the notes running from six, 12 and 18 months.

George R. Whitehead, the temporary receiver of the firm, has been hard at work making up his inventory, and stated that he would be in a position to file schedules after this week in case there was an adjudication and the bankrupts did not file them. It was hard, he stated, to determine exactly the amount of the assets and liabilities, owing to the complicated condition of affairs.

When asked if it was true that he was serving without compensation whatsoever Mr. Whitehead said it was, and that he was doing the work purely for the benefit of the creditors to conserve the assets to the best advantage of the creditors and debtors, and that he would neither directly nor indirectly expect any compensation therefor. The only expense of the receivership will be that for clerk hire and the attorney's fee.

The members of Chas. F. Wood & Co., who are Charles F. Wood, Elmer E. Wood and John B. Wood, were among the incorporators last week of a company known as Chas. F. Wood & Co., to deal in jewelry and precious stones and manufacture jewelry, with a capital of \$100,000, the other incorporators being L. F. Reed, the attorney for the company, and H. W. Showers. John B. Wood explained that the corporation was formed to take over the business of the old partnership in case a settlement was effected with the creditors, and the corporation would take the new offices that were engaged at 17 Maiden Lane.

Death of Adolph Ludwig.

Adolph Ludwig, senior member of A. Ludwig & Son, manufacturers of jewelry at 75 Nassau St., New York, died Monday at his home 51 E. 122d St., Manhattan. Mr. Ludwig had been ill for nearly a year and his illness for the last six months had prevented him from attending to business. He was 61 years of age.

Mr. Ludwig was born in Germany and had lived in New York nearly 40 years. He learned the jewelry trade in Germany, where he engaged in business for himself before coming to this country. He had been in business for himself and in partnership with his son, Charles Ludwig, in New York for 30 years.

The surviving relatives include his widow, three daughters and five sons. The funeral will take place to-morrow (Thursday) afternoon at 2 o'clock from the late home

of the deceased. The interment will be at Woodlawn Cemetery.

The business will be continued by Mr. Ludwig's sons without change.

Receiver Alleged to Have Been Unjustly Appointed for Baltimore Jewelry House, Removed by the Court.

BALTIMORE, Md., April 25.—In the action between John W. Mealy & Sons Co. and the Third National Bank, which came up in Circuit Court No. 2 before Judge Gorter to-day, the receiver appointed several days ago, by unjust methods as claimed by Mr. Mealy, was removed by the court. The company was also restored to Mr. Mealy and his sons, who own 497 out of the 500 shares of stock which constitute the capital stock of the concern.

The New York Jewelers' Board of Trade, representing about 90 per cent. of the New York creditors, and every creditor in the city of Baltimore, lined up behind the John W. Mealy & Sons Co. in the contest. Mr. Safford, secretary of the Jewelers' Board of Trade, came to Baltimore and after examining the records of both sides of the controversy and investigating the books of the company, decided that the company was entitled to the support of the organization. Mr. Safford engaged Messrs. N. Rufus Gill & Sons to represent them at the trial to co-operate with the Mealy company.

The order of the court removing Capt. Robert M. Spedden from the duties of receiver, also gave the John W. Mealy & Sons Co. until May 10 to file an answer to the petition for a receiver. During the argument, to-day, Mr. Mealy's counsel, Crain & Hershey, declared on behalf of the jewelers that their losses growing out of the Baltimore fire of 1904 were very great, owing partly to the loss of their books with all records of the persons who are indebted to them.

Trans-Atlantic Voyagers.

B. S. Newman, of Frohman & Co., Cincinnati, O., sailed last week.

Morris Lissauer, New York, sailed on the *Kronprinzessin Cecile*, April 14.

N. Harrison, of Harrison Bros., New York, sailed recently on the *Baltic*.

F. G. Thearle, Chicago, sailed recently from New York for Italy on the *Republic*.

A. E. Madsen, of Rettig, Hess & Madsen, Chicago, sailed, last week on the *Adriatic*.

L. Beckman, of the L. Beckman Co., Toledo, O., accompanied by his wife, sailed last week.

S. D. MacPherson, of MacPherson, Roubaud & Co., Providence, R. I., sailed recently on the *Oceanic*.

Max Arnstein, of Arnstein Bros., New York, accompanied by his family, will sail to-morrow on the *Deutschland*.

James P. O'Donald, at one time a jewelry salesman and later engaged in business for himself, died at his residence, 1101 N. Carrollton Ave., Baltimore, Md., last Wednesday morning, after a lingering illness. The deceased was 34 years of age and is survived by a widow and one son.

Death of Albert W. Adcock.

CHICAGO, April 25.—Albert W. Adcock, of the Shourds-Adcock-Teufel Co., died at his residence, 327 Warren Ave., on Wednesday, of an affection of the spine, after having been ill since October last. He was buried from his late residence at 1:30 p. m. to-day. The interment was at Rosehill Cemetery with Masonic rites.

Albert W. Adcock was born at Melton-Mowbray, Leicestershire, England, on Aug. 6, 1847, and was therefore 61 years old at the time of his death. At the age of three years he was brought to this country by his parents, and was educated at the Dearborn school. At 26 years of age he entered the employ of C. D. Peacock, and at first occupied a position in the office. His natural ability as a salesman asserted



THE LATE ALBERT W. ADCOCK.

itself, and he graduated from the office to the salesroom, where he remained for 23 years. There was no better jewelry salesman in Chicago than Albert W. Adcock. His genial manner and buoyancy of spirit won him many friends and he built up a valuable clientele.

In 1895 he left Mr. Peacock to assume the vice-presidency of the Shourds-Adcock-Teufel Co., which corporation was formed at that time.

Deceased was a mason of high degree, and at the time of his death was a member of the following bodies: Wm. B. Warren Lodge, No. 209, A. F. & A. M.; Wiley M. Egan Chapter, No. 126, R. A. M.; Apollo Commandery, No. 1, K. T.; a life member of Oriental Consistory, S. P. R. S., 32d degree, and an honorary member of Eber Preceptory of York, England. He was a member and trustee of the Illinois Club, and was a trustee and executor of the Henrietta Snell estate. He is survived by a widow, Mrs. Carrie Young Adcock, and two sons, Albert Y. and Earl E. Adcock.

John Keating, Amer, Ia., is again established in the retail jewelry business.

EICHBERG & CO.,

IMPORTERS AND CUTTERS OF

DIAMONDS,

65 NASSAU STREET, (Prescott Building.) NEW YORK.

"If It Is Chopard's Idea, It's Ideal"



Combs

They are without question the biggest profit earners of the season and represent the highest art in comb making, and finest workmanship in setting. We have every style; steel, silver and gold-plated, set with cameos, white and colored stones, as well as a complete assortment of jet combs in both dull and bright.

Remember, we have anything you may require in Novelty Jewelry, Jet and Pearl Strings in stock.

Selection to all reliable dealers upon request.

CHOPARD FRÈRES CO., 56 Maiden Lane, NEW YORK, N. Y.
Factory, 35 Rue des Trois Bornes, PARIS, FRANCE

Providence.

TRADE CONDITIONS.

Trade conditions continue to have a better tone. The jewelers, now that the period of financial uncertainty has practically ended, are beginning to look back and congratulate themselves on the fact that not one of the larger and well established concerns went into bankruptcy. The outlook for the next few months seems to be bright. Salesmen returning from the west have brought in their customary orders and are now preparing for the Pacific coast and other trips.

"Gus" Rodenburg is making a western trip for the Aetna Optical Co.

The Lees Findings Co. will remove its shop from Pine St. to 9 Callender St. May 1.

Arthur O. Ostby, of the Ostby & Barton Co., and his wife are enjoying a respite at Lakewood, N. J.

Among the buyers who were in this city last week were J. C. McMurphy and Theodore Jacobs, Chicago.

Reuben Mason, of the Potter & Buffinton Co., who has been in charge of the New York office, is now making a western trip for that concern.

The annual shut-down of the Ostby & Barton Co.'s factory occurs this week. This action is to be taken in order that an account of stock and inventory may be made.

The charter of the American Enamel Co. was amended by the General Assembly last week. The amendment provides for an increase in the capital stock of the corporation from \$50,000 to \$100,000.

Articles of incorporation have been taken out by James C. Doran & Sons. The concern, according to the articles, proposes to manufacture and sell jewelry findings and novelties and to handle real estate.

The Union Trust Co. will reopen its doors, May 4, and the money market, which has been tight in this city since the panic of last Fall, will be considerably relieved. All depositors who have claims of \$100 or less will be paid in full on demand. This will affect many hundred jewelry workers who had put small sums by for a rainy day.

Negotiations are under way by which the property of the Vesta Knitting Mills, which includes a large six-story jewelry building at Claverick and Basset Sts., will pass into the hands of New York parties whose names are not known here. It is said that the price offered for the property is \$1,500,000. The jewelry building itself always has been a paying proposition, among its tenants being the big shops of Smith Bros. and the B. B. Smith Co.

The first annual meeting of the Manufacturers' Refining Co. was held Wednesday afternoon. The concern has only been in active operation for three months, yet the financial statement which was rendered at the meeting was of a most satisfactory nature. Charles A. Russell, Roswell C. Smith and Harry Cutler were elected directors for a term of three years. The following officers were re-elected by the directors: President, William A. Copeland; vice-president, Everett I. Rogers; treasurer, William P. Chapin; secretary, Harry Cutler.

Local jewelers were greatly interested last week in an exhibition of the work of the local detective bureau. Harrison Bens, a wealthy mill owner of London, England, put up at the Crown Hotel, and had with him a suit case containing diamonds and

CORAL

All Kinds of Coral Specialties for Jewelers

**DROPS
BUTTONS
LENTILLES**

**CORAL
NECK-
LACES**

All Shades and Sizes

Graduated and Uniform



CORAL MANUFACTURING COMPANY

CORAL

**Extra Rose
CORAL
A Specialty**

Gold Medal
St. Louis, 1904

Grand Prix
Liege, 1905

BORRELLI & VITELLI

3 Via Amedeo, Terre del Greco (Italy)

401 Broadway, New York
Telephone, 5412 Franklin

19 Rue d'Hauteville, Paris, France

LOUIS FELDENHEIMER

Importer and Cutter of

PRECIOUS STONES AND PEARLS

41 MAIDEN LANE

NEW YORK

Gems and Precious Stones

Cloth, Postpaid, \$1.00. Published by The Jewelers' Circular Publishing Co., 11 John Street, New York.

other gems valued at about \$10,000. On Sunday evening Mr. Bens discovered that two sapphire pins valued at \$1,500 had been stolen. One was a pendant with a brown two-carat diamond at the top, a pure white half-carat stone in the center and a large pear-shaped yellow diamond at the bottom. The other pin contained a two-carat pure white diamond and a ruby of the same weight. Both were handsome specimens of the London jewelers' art, the diamonds coming direct to Mr. Bens from Kimberly. The detectives arrested three bellboys and found the missing pins in their rooms.

North Attleboro

Roy MacPherson has resigned as salesman for Riley & French.

Arthur Chace left, Sunday, on his initial trip for Mandalian & Hawkins.

George L. Paine & Co. was closed last week while a new floor was being laid.

I. S. Richter will represent Hanlon, Thornton Co. in the middle west hereafter.

Foster Clark is receiving congratulations over the arrival of a daughter at his house.

Lawrence Kennedy was in New York last week on business for Miller, Fuller & Whiting.

The United Brush Co. has begun to move its machinery to the new quarters in Pawtucket.

Extensive alterations are being made to the larger building of the cluster of shops known as the Company Shops.

Robinson Bros. have moved to its new quarters in the shop at Plainville occupied by Maintien Bros. & Elliot before their removal to North Attleboro.

Mandalien & Hawkins have completed the task of moving to the Manufacturers' building. Over 2,500 square feet of extra floor space is secured by the removal from the Totten building.

F. G. Grant, who has been superintendent of the shipping department of J. F. Sturdy's Sons for a number of years, has resigned because of poor health. Philip R. Cook has been promoted to the place.

Walter Ginder, of Ginder Bros., wholesale jewelers of Birmingham, Eng., was the guest of his cousin in North Attleboro last week. Mr. Ginder has been in America buying jewelry for his concern.

An automobile owned and operated by Alton H. Riley collided with an electric car last Thursday. The car unexpectedly took a turn. The automobile was damaged considerable but fortunately nobody was hurt.

Riley & French, the W. & S. Blackinton Co., G. C. Hudson & Co., and C. Ray Randall & Co. closed last Thursday for 10 days. A new boiler is being installed. A new brick chimney has recently been erected, which is the biggest in town.

During the past week there has been a steady line of salesmen leaving for the west and middle west to gather in the Spring business. Now practically every traveler is on the road. This trip is an exceptionally important one. Among those who have gone out during the past few days are: Fred S. Gilbert, George Angell, R. N. Squire, Mr. Booth, Mr. Mandalian, Charles Martin, for F. S. Gilbert, and Fred Carpenter.

William H. Herring, who last Thursday

celebrated his 82d birthday, has a record for continuous work for one concern. He has been employed by E. Ira Richards & Co. for 58 years and is still working for that firm. Mr. Herring began work at the age of 14 for Richards & Coddington, under which name the firm was then operated. He left for a few years, but in 1850 returned to the concern, and has labored continuously since. He has missed but very little time during this long range of years. Mr. Herring is a native of North Attleboro, having been born in the section known as Robinsonville April 23, 1826.

A new concern, which will be known as the Plainville Mfg. Co., is in process of organization, but the personnel has not been sufficiently determined to be made public. It will be a stock company to include experienced workmen. The space in the building of the Plainville Land Co., at one time occupied by Chapman & Barden, has been rented. The machinery is being installed and the new concern will be ready for business within a comparatively short time. The citizens of Plainville are expecting much of the new concern, as they appreciate the fact that it was in a similar manner that the Plainville Stock Co. had its origin years ago.

Attleboro.

The Horton-Angell Co. factory closed down this week.

John M. Fisher, of J. M. Fisher & Co., has been kept to his home lately by illness.

F. H. Sadler & Co. last week donated \$50 to the relief fund for the sufferers by the Chelsea, Mass., fire.

James E. Blake was last week chosen park commissioner to succeed the late Charles E. Bliss, of Bliss Bros.

John C. Cummings, recently retired from J. C. Cummings & Co., is planning to spend the Summer at Oak Bluffs, Mass.

Ralph H. Cole, dealer in Masonic emblems, has removed his office to 18 Horton block, owing to the need for larger quarters.

Invitations have been issued for the wedding of Frank L. Briggs to Miss Miriam Bertha Rowe, daughter of Mark E. Rowe, jewelry manufacturer.

Claim has been officially made that Henry A. Streeter, a jobbing jeweler, has been illegally removed from the local office of registrar. The matter is under investigation.

Hon. Sidney O. Bigney, of S. O. Bigney & Co., who lately won a State delegateship to the Republican National Convention, is now being vigorously exploited for lieutenant-governor.

The Superior Court last week awarded \$344.44 to the Syracuse Plating Co. in its action against the Frank Mossberg Co. The Syracuse people sued for \$500, the defendants claiming the goods were improperly shipped and arrived too late to be of value.

The Bliss Bros. Co., through treasurer Herbert C. Bliss, last week filed the following annual corporation report: Machinery, \$37,952; cash and debts receivable, \$41,973; manufactures and merchandise, \$53,572; capital stock, \$60,000; accounts payable, \$19,539; profit and loss, \$53,058.

Smith & Crosby announced Saturday

that a decision has been reached to retain the old name hereafter. On the recent withdrawal of William H. Smith, and the accession of Alfred R. Crosby's sons as partners, a corporate business style was considered, but the plan has now been given up.

The handsome mansion left by the late George A. Dean, of G. A. Dean & Co., is being remodeled for a home for James E. Blake, of the James E. Blake Co. A new dwelling is being prepared for Mrs. Dean, widow of the original owner. The house now occupied by James E. Blake has been purchased by his nephew and partner, William H. Blake.

George H. Sykes, of Sykes & Strandberg, has been acting as traveling salesman lately owing to his partner, Gus Strandberg, the regular salesman, being incapacitated. Mr. Strandberg, while on his last trip, met with an apparently minor accident, straining his back. More serious results followed, however, as erysipelas set in. Mr. Sykes ordinarily runs the shop, but was forced to fill a dual role for a time.

A meeting of the creditors of the D. A. White Co., manufacturing jewelers, was held at the company's office last week. The outstanding accounts amount to \$7,136.21. The merchandise liabilities amount to \$9,673.96. This company consists of Damon A. White and relatives, the latter holding claims of \$41,000 which, some of the creditors say, will be contested. A committee of three, consisting of Harry Mays, A. S. Ingraham, of A. S. Ingraham & Co., and F. C. Murray, was elected by the creditors to investigate the affairs of the company and report later.

Attleboro manufacturing jewelers' hospitality was freely shown Saturday and Sunday to the State officials of Odd Fellowship, the occasion being an extensive celebration of the anniversary of the order. The officers were entertained Saturday with a tour of the most interesting of the jewelry factories, and Sunday with a dinner and divine worship. The committee of Odd Fellows in charge embraced Hon. Sidney O. Bigney, of S. O. Bigney & Co.; Edward A. Sweeney, of W. H. Wilmarth & Co.; James E. Blake, of the James E. Blake Co.; Maxy W. Potter, with J. M. Fisher & Co.; Emmons D. Guild, of W. H. Wilmarth & Co.; David E. Makepeace, of the D. E. Makepeace Co.; Ernest D. Gilmore and William L. King, of E. D. Gilmore & Co.; Charles H. Tappan and F. C. Wilmarth, of the D. F. Briggs Co.; Albert S. Ingraham, of A. S. Ingraham & Co.; Fred L. Torrey, of F. L. Torrey & Son; Charles O. Sweet, of C. O. Sweet & Son Co.; Harry P. Kent, of F. W. Weaver & Co.; Clarence L. Watson, of the Watson & Newell Co., and Fred A. Newell, formerly of the same company; Ezekiel Blake, of the James E. Blake Co.; David L. Low, of the D. F. Briggs Co.; Harry Holbrook; Robert B. Maedonald, of R. B. Maedonald & Co.; Charles C. Wilmarth, of the Walter E. Hayward Co.; Walter E. Marble; John W. Luther, of J. W. Luther & Co.; Joseph Finberg, of Joseph Finberg & Co.; E. T. Bright, and W. H. Lyons, all either manufacturers, salesmen, or men at the head of allied industries.

"ASK YOUR JOBBER"



THE UP-TO-DATENESS OF THE
UR RINGS IS AGAIN PROVED
BY A COMPLETE LINE OF CAMEO
GOODS WITH HAND-PIERCED AND
SOLID SHANKS IN AN ENDLESS
VARIETY.

The Untermeyer-Robbins Co.

Seventy-One Nassau Street, New York

ARTHUR REICHMAN

DEALER IN

AMERICAN BAROQUE PEARLS

65 Nassau St.

New York

SEND YOUR SWEEPS to the Cincinnati Gold & Silver Refining Co.

REFINERS, ASSAYERS AND SMELTERS

Office, 523 Elm Street; Works, 2257 Eastern Avenue; CINCINNATI, OHIO

Highest Price Paid for Gold, Silver and Platinum Platinum and Gold Filings Refined by the Russian Method

Practical Course in Adjusting.

Published Price, \$2.50. Special
Reduced Price, \$1.50. All jobbers,
or Jewelers' Circular Publishing Co.

Lancaster, Pa.

Christ. M. Bowman, of Ezra F. Bowman's Sons, visited Harrisburg last week.

G. S. Kurtz Zook's store has been improved by the change of position of his office, which is now provided with every up-to-date equipment.

Hart J. Smith, Philippi, W. Va., whose store was burned out about two months ago, has notified his Lancaster friends that he has again resumed business.

Miss Lillian Swope, for some years foreman of the dial department of the Hamilton Watch Co.'s factory, was married, April 22, to George E. Askew, of New York.

John B. Roth, Jr., has just finished a handsome large past commander's jewel for Lancaster Commandery, Knights Templar, which goes to the retiring commander.

These traveling salesmen of the Non-Retailing Co. have come in to help take an inventory of stock: E. R. Kant, from the west; F. A. Wheeler, from Michigan and Indiana, and W. N. Shute and C. E. Foose from the south.

Considerable interest is felt in the offer of J. T. Wilson Dubbs of a gold watch with 17-jewel Hamilton movement to the member of the Lancaster Tri-State League baseball team which will make the first home run on the home grounds.

Among the jewelers visiting this city last week were: Charles Boniface, Louisville, Ky.; Jacob Esch, Intercourse, Pa.; George W. Townsley and J. H. Sensenig, New Holland; R. D. Fieles, St. Louis; Mark Hoffer, Richmond, Va., and Jules Markel, Charleston, S. C.

John J. Bowman, of the Ezra F. Bowman Technical School, visited York, Pa., last week. W. P. Hall, of Chagrin, O., late with Westfield, of New York, has entered the school for a course in engraving and watchmaking. John J. Diebold, of Buffalo, N. Y., has become a student in watchmaking. The students of the school have organized a baseball team, and have booked games with a number of Lancaster County clubs. The management of the school has offered a beautiful gold medal to the student making the highest average during three consecutive months.

Albany, N. Y.

Detectives last week, in a North Pearl St. jewelry store, found a seedily dressed man who was endeavoring to dispose of a 1½-carat diamond ring, valued at \$250, for \$50, and a hunting-ease gold watch valued at \$150 for a small amount. The man had been drinking and was ordered locked up.

The will of August Schnell, jeweler at Troy, has been filed for probate. Schnell willed his jewelry store, under certain conditions, to Paul C. Saehrig. Saehrig is to continue the store during the life of Lucinda Schnell and pay her, out of the earnings, \$150 a month and \$250 on rent each year. After her death Saehrig is to pay two bequests of \$300 a year to two old servants. Should Saehrig decline to carry on the business under the conditions imposed, it is to be sold and Mrs. Schnell is to have use of the proceeds during her lifetime. Schnell's estate is valued at \$20,000.

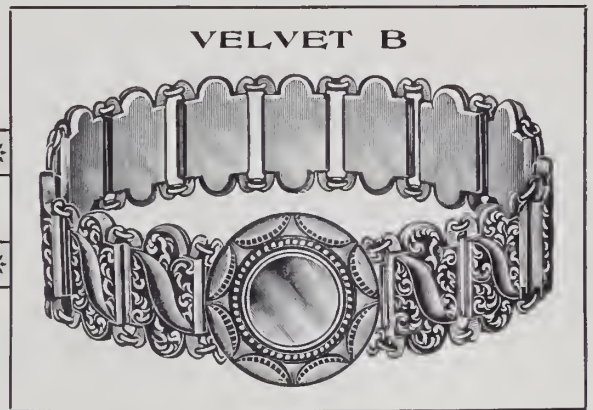
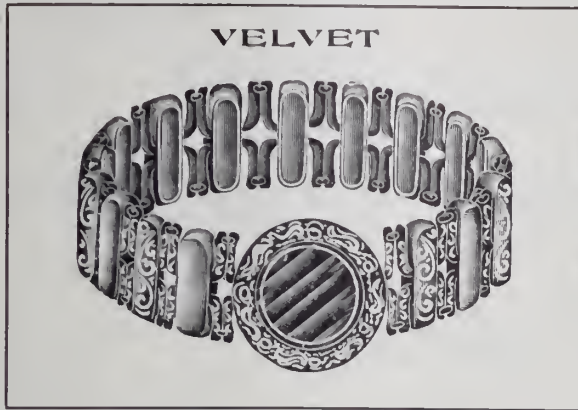

For the trade who wish to handle a cheaper adjustable bracelet, the makers of the well-known "Velvet" have produced a line to be known as "Velvet B"; will wear, will not break, and at a price that will make it a seller.

MASON, HOWARD & CO.

Factory: ATTLEBORO, MASS.

New York Office: 180 Broadway



While

WHILE your business is somewhat dull you will find it to your advantage to look up the local order for

Class Pins

Write us for Catalogue J 30. and Samples

THE CHAS. M. ROBBINS CO.

MANUFACTURING JEWELERS AND ENAMELERS



ATTLEBORO

::

::

::

MASSACHUSETTS



GORHAM BRONZE

MEMORIAL TABLETS

During recent years the bronze memorial tablet, whether commemorative of the virtues of the dead or of the munificence of the living, has markedly increased in popularity. In churches, Hospitals, Libraries, State or Municipal Buildings, it occupies a prominent place.

To those jewelers, therefore, who may be consulted in this regard the Gorham Company desires to point out that the designing and fashioning of artistic Memorial Tablets form a very noteworthy branch of the Gorham Bronze Foundry.

Suggestions, attractive sketches or competent models in wax as well as careful estimates of the cost of Memorial Tablets of any description will be very gladly furnished should occasion arise.

THE GORHAM COMPANY,



CHICAGO,
137 Wabash Ave.

Silversmiths and Goldsmiths

Fifth Avenue and 36th Street, New York.

BRANCHES:

NEW YORK,
23 Maiden Lane.

SAN FRANCISCO,
Temporary Office:
1103 Broadway, Oakland, Cal.



LONDON,
Ely Place.

WORKS: Providence and New York.

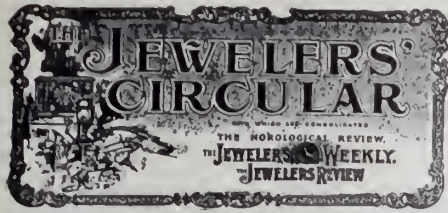

PUBLISHED EVERY WEDNESDAY BY
THE JEWELERS' CIRCULAR PUB'G CO.
 L. J. Mulford, Pres. & Treas. V. S. Mulford, V. P. & Sec.
 11 JOHN ST., COR BROADWAY, NEW YORK.
 TELEPHONE: CABLE ADDRESS:
 1148 CORTLANDT. JEWELAR, NEW YORK.

VOL. LVI. APRIL 29, 1908. No. 13.

Subscription in United States and Mexico, \$2.00
 Dominion of Canada, 3.00
 Other Countries in Postal Union, 6.00
 Single Copies, .10
 Remit by check or money order. Remittances in money are at sender's risk.

Index to News and Special Articles.

Page.

A Fine Presentation Set. Illustrated on front cover; text on.....	45
Decorative Etching on Silverware.....	45
Pearling in Australasia.....	46
Repoussé Work and Chasing—(Continued)....	47
A Novel Baptismal Font Made by a San Diego, Cal., Jewelry Firm.....	47
Reigning Paris Fashions.....	49
The News From England.....	51
Death of Karl Breuninger.....	51
Death of E. S. Ettenheimer.....	51
Jos. Brown & Co. Refuse to File Schedules—Unofficial List of Creditors Compiled.....	53
Lafayette Call Commits Suicide.....	53
Detroit's Auctioneers' Licensing Ordinance Brought Before Council Ordinance Committee.....	53
Creditors Pile Involuntary Bankruptcy Petition Against D. & A. Brinker, New York... Maiden Lane and John St. Connected by Arcade in the New Silversmiths' Building.....	55
Examination of Geo. H. Carpenter Continues.....	55
Death of H. N. Konrad.....	55
Thieves Loot Cleveland Jewelry Store While Clerk Talks to Accomplish.....	55
West Virginia Retail Jewelers' Hold Important Annual Convention at Clarksburg.....	57
Death of David Jacobs.....	57
Jewelry, etc., Exported from New York.....	57
Importations at New York.....	57
Gold Bars Withdrawn and Exchanged.....	57
"Automobile Clock Thief" Taken to New Haven for Trial—Wanted in Many Cities... Shipping Clerk Charged With Stealing Yachting Trophy and Selling the Silver.....	59
Head of the London Diamond Syndicate Tells of the Stability of the Diamond Market... Excellent Work in Jewelry Designs Done by Class of Attleboro Y. M. C. A.....	61
Nest No. 1 of the Noble Order of Ku-Kus Instituted at Piqua, O.....	61
Optometry Law Passed by New York Legislature.....	63
Death of Julius Schaeppi.....	63
Oklahoma Retail Jewelers' Convention.....	63
Receiver for Baltimore Jewelry House Removed by the Court.....	65
Death of Adolph Ludwig.....	65
Death of Albert W. Adcock.....	65
Receiver of Chas. F. Wood & Co. to Accept No Fees—Bankrupts Offer a Settlement... Diamonds of Various Colors.....	65
New Enterprises.....	86
Patent Department.....	90-91
Trade-Mark Information Wanted.....	93
Large Silverware Contract Placed by the Hariman Railroad and Steamship Lines.....	93
Pearl Fisheries of Venezuela Leased.....	93
A Catechism of the Lever Escapement—(Continued).....	95-97
Remarkable Clock Showing Movement of Earth, Sun and Moon.....	99
A Window Display Consisting of a Diamond Cross and a Crown Worth \$200,000.....	104
How to Meet the Competition of the Mail Order House—(Continued).....	105
A Jeweler Whose Odd Hobby is the Taming of Tarantulas.....	105
The Way of the Enterprising.....	105
An Interesting Business Card.....	105
Letter Heads.....	106
Newspaper Advertising.....	107
Just Reason for Optimism.....	107
Workshop Notes and Queries.....	109
New Methods of Making Chains.....	109
Early English Pottery—Posset Pots.....	111
An Opportunity to Push American Cut Glass in Europe.....	111
Buyers' Information Bureau.....	113
Some Benefits of Organization.....	113

State Stamping Laws Continue to Be Passed.

SINCE Governor Fort of New Jersey signed THE CIRCULAR - WEEKLY'S

State Stamping Law, as noted in the last issue, the newspapers of many States have been commenting favorably upon the enactment of this statute and complimenting the State of New Jersey upon having such a law. Most of them, however, seem to be unaware of the fact that similar laws had previously been passed by North Carolina, Colorado, Rhode Island and other States.

This law, which was drawn for THE CIRCULAR-WEEKLY, is intended to conform to and supplement the National Stamping Law, and has been indorsed by the United States Stamping Law Committee, through whose agency, with the co-operation of local jewelers, it was introduced in the States which have already passed it, and in a number of others besides. There is no reason why the law should not be on the statute books of every State in the Union, nor why the jewelers and public of all States should not receive the same protection against the swindler who operates within the State lines as they now do, under the national law, against men of this character who ship their product from one State to another.

Canada as a Market for Jewelry.

CANADA is constantly becoming a more and more important market, not only to American manufacturers and exporters, but to those of other countries as well. Her trade is steadily increasing, and her import values are constantly growing larger. During the year ending March 31, 1906 (the end of the fiscal year in Canada) her importations of watches amounted to \$931,074, of which \$689,389 came from the United States, \$27,440 from the United Kingdom, and \$214,245 from other countries. In 1907 the total value had been increased to \$1,027,491, and the United States' share to \$783,043, nearly \$100,000, while the importations from the United Kingdom had only been increased to \$28,674, only a little over \$1,000. From all other countries the value was \$215,774.

During the same fiscal years her total importations of clocks were \$320,352 and \$355,905, respectively; the United States' share in this line increasing from \$254,164 to \$284,532, the United Kingdom's from \$11,837 to \$15,426, and other countries from \$54,351 to \$55,947.

Her imports of jewelry are also steadily increasing, and so is our share in that trade. In 1906 we shipped to Canada jewelry to the value of \$654,902, and in 1907, \$853,131; the importations from the United Kingdom were increased from \$83,643 to \$148,952, and from other countries from \$94,848 to \$149,533. This makes a total increase for the year from \$320,352 to \$355,905.

We have also a very steadily growing trade with Canada in optical instruments, in which there was an increase from \$284,127 in 1906 to \$331,081 last year; from the United Kingdom the importations increased from \$49,704 to \$64,523, and from all other countries from \$62,435 to \$64,928.

It must not be forgotten that a large percentage of this increased demand for

To insure publication all changes of copy for standing advertisements must be received not later than Friday noon preceding date of issue.

American goods is due to the fact that in the provinces there are many American immigrants, and they prefer to buy goods of American manufacture. Then, too, a great many American capitalists are going into the northwestern part of Canada and are investing large amounts of capital in manufacturing plants, and that brings to the United States a demand for more American goods. Another feature tending to the enlargement of the United States' trade in Canada is undoubtedly to be found in the fact that our magazines with their advertisements of American goods are to be found on the news-stands in all of the larger cities and towns.

One particular point to which our exporters should pay attention in packing goods for Canada is to be sure to see that the boxes or packages are numbered to correspond with the invoice numbers, as this saves much delay in customs houses.

A National Organization of Wholesale Jewelers.

FOR some time past there has been agitation in certain circles for a national association of wholesale jewelers, and several propositions with this end in view have been made to the trade. According to some of the statements credited to the advocates of this proposition and to some of the circulars sent out, it is apparent that many of the people behind the movement do not appreciate the fact that the trade has to-day a national organization of wholesale jewelers which is one of the strongest, as well as one of the largest and most important bodies in commercial circles of this country. This is the Jewelers Board of Trade, which in its membership of 570 takes in firms from the Atlantic to the Pacific and from the Lakes to the Gulf. Though the headquarters is in New York, it has branches in Chicago and Providence, each with a regular staff of employes and under the direct supervision of directors in these cities.

Among its 530 regular members and 40 associate members there is a large majority of all the wholesale firms and manufacturers in the jewelry and kindred lines, and these are to be found in every large jewelry manufacturing center of the country. Of these there are 265 in New York, 90 in Chicago and vicinity, 23 in Boston and vicinity, 40 in Newark, 20 in Philadelphia and vicinity, 70 in Providence and the Attleboros, two in Cleveland, 13 in Cincinnati, four in Detroit, four in Pittsburg, 11 in Buffalo and vicinity, as well as one or more members in the smaller manufacturing centers, such as San Francisco, New Orleans, Atlanta, etc.

With its large membership, its several

A Profitable Investment for You

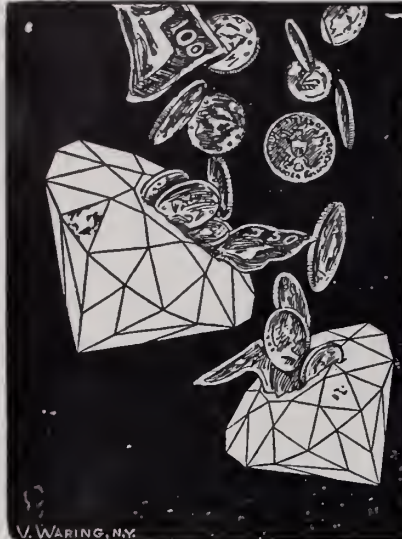

Put your money

and get your customers to put their money in
DIAMONDS
no better investment to-day.

The Jewelers Board of Trade announced recently that cable despatches received here from London said that the De Beers and Premier Diamond Mining Companies, controlling 97 per cent. of all the diamonds mined, had made a contract in which they agreed that there shall not be the slightest reduction from the present prices of diamonds.

We have a large stock of
DIAMONDS
on which we will make very
LOW PRICES
that cannot be duplicated when present stock is sold. We import the stones direct and sell them as close as anybody in the country does for
DIAMONDS
of equal quality. We carry a large stock, Loose and Mounted, and the jeweler who sends to us for a selection not only gets
LOW PRICES
but also a liberal assortment and what is of utmost importance, he gets it promptly. Send us your orders.

V. WARING, N.Y.

CROSS & BEGUELIN

Importers and Cutters of Diamonds and Precious Stones

43 Rue de Meslay, PARIS

Telephone,
480 John

31 Maiden Lane, NEW YORK



Trade-Mark

OUR guiding principle has always been to incorporate as much artistic skill and good material in the construction of our jewelry as possible. This is contrary to the skimming, economic operations so extensively practiced in the manufacture of inexpensive gold jewelry. In observing this standard we naturally sacrifice the petty profits resulting from the less exacting methods of others; nevertheless our jewelry is consistently low priced and of a quality away beyond the ordinary.

Ask to see it and look for our trade-mark—the imprint of originality and all that's good.

85 Sprague Street
PROVIDENCE, R.I.

H. A. KIRBY

9-11-13 Maiden Lane
NEW YORK CITY

branches and its many correspondents, as well as its close relations with the retail and wholesale trade throughout the country, there is practically nothing among the subjects suggested (for the agitation of which a national wholesale jewelers' association is proposed) that the Jewelers Board of Trade cannot take up and act upon with much more effect and better results than any new or loosely bound organization that could be devised.

Those who speak about the jewelry trade not having a national association for its wholesale lines have either forgotten, or deliberately closed their eyes to, the existence of the trade's largest, strongest and most powerful organization. In fact, they are apt to remind one of the absent-minded man who sent for a ham sandwich as he was going to a banquet.

Rochester.

A letter, a cigar and a match caused a \$2,000 fire in the jewelry store of C. H. Rickler, on Joseph Ave., last week. Rickler was cleaning a clock with benzine. His wife was out of town and wrote him a letter. Rickler stopped cleaning long enough to read the letter and thought he would enjoy a smoke while reading. He struck a match and there was a loud report. Rickler tried to smother the fire with his coat, but to no avail. In his excitement he failed to turn in an alarm after breaking the glass of the fire alarm box. There was \$1,500 insurance on the stock and store. The damage to the building will amount to about \$400.

A. R. Kime, the "ocular refractionist," in the Cutler building, who has been selling gold-mounted eyeglasses for \$1, and made examinations free, is said to have left the city, leaving obligations said to amount to over \$2,000 behind. His offices have been stripped of their furnishings by the installment houses, which supplied them and no information as to the whereabouts of the "man who broke the high prices" can be found. It is said, Kime owes a local jewelry house over \$200 for goods obtained, with the understanding that he was to have credit for \$200. Plumb & Plumb, attorneys, hold a judgment against Kime, and they had correspondence with Troy lawyers a few days ago, leading up to an action to attach Dr. Kime's possessions there.

Eugene C. Blackburn, who was arrested April 18 at Greensboro, N. C., on the charge of stealing a diamond ring from the jewelry store of R. C. Bernau and held in \$400 bail to appear before the mayor, has waived examination and has been bound over for trial in the same bail. Blackburn called at Mr. Bernau's store April 18 and asked to see some diamond rings which were in the show window, but bought nothing and went away. A short time later Mr. Bernau, on looking at the trays, discovered one of the rings to be missing. The police were notified and the man was arrested at the station. To the police he finally confessed and at their suggestion went to his room and brought out the missing ring. A search of the room later revealed a number of other articles, among which were seven scarfpins, set with pearls, diamonds and other stones.

New York Notes.

Adolph Rosenthal, watch specialist, has moved from 12 John St. to 45 John St.

Ernest Bliss, of Bliss Bros. Co., North Attleboro, Mass., called on friends in town last week.

E. I. Rogers, of Parks Bros. & Rogers, Providence, R. I., spent Thursday and Friday in town.

Albert B. Randall, representing the Codding & Heilbron Co., has returned from a western trip.

John F. Turner, jeweler's auctioneer, has moved from 2 Maiden Lane to room 1702, 15 Maiden Lane.

Frank M. Todd, of Reid & Todd, Bridgeport, Conn., was in this city last week on business.

Capt. R. E. Burdick, of the Bowler & Burdick Co., Cleveland, O., visited in this city during the past week.

J. Codding, of the Codding & Heilbron Co., North Attleboro, Mass., was in town the latter part of last week.

E. R. Kent & Co., manufacturers of steel drills, etc., for the trade, have moved from 51 John St. to 282 Pearl St.

Van Antwerpen, Van den Bosch & Co. have moved their offices and factory from 187 Lafayette St. to 45 John St.

The Towle Mfg. Co., 41 Union Sq., will occupy sales rooms in the Silversmiths' building, 17 Maiden Lane, after May 1.

Leopold Stern, of Stern Bros. & Co., 68 Nassau St., was selected a presidential elector at the recent Republican convention.

Frank Herschede, of the Frank Herschede Co., Cincinnati, Ohio, was in town last week on a business and pleasure trip.

L. Blackinton, of W. & S. Blackinton Co., North Attleboro, Mass., stopped in town Friday. He has started on a Western trip.

There has been on exhibition at the Fifth Ave. salesrooms of the Gorham Co. during the past week a bronze head of the late Carl Schurz, by Winifred Holt, which was modeled from life.

Frederick Boehenberger, a diamond cutter, killed himself with gas April 21 in his home at 350 Bleeker St., Williamsburg. Boehenberger had been out of work for seven months. He is survived by a widow and four children.

Passers-by have been much interested during the past week in an exhibit of a large biscuit of fine Para rubber, seen in the sales rooms of the L. E. Waterman Co., 173 Broadway. The mass of rubber is 9½ feet in circumference and weighs 763 pounds.

E. A. Lehmann & Co. have been incorporated under the laws of New York State to manufacture jewelry, with a capital of \$15,000. The incorporators are Emil A. Lehmann, Olga E. Lehmann and S. W. Stern. The firm has moved from 20 Maiden Lane to 45 John St. They were at 20 Maiden Lane 13 years. The incorporation is to facilitate the handling of the business.

There will be held in Madison Square Garden, from May 25 to June 30, the first exhibition of practical mining methods and products of mines in all parts of the world ever held in New York. The exhibition is under the management of the Mining Exposition Co., which was incorporated a little

over a year ago. There will be exhibits of all sorts of precious stones included in the display.

Owing to a similarity in names the firm of John R. Wood & Sons, diamond importers and manufacturers of rings, 170 Broadway, have been annoyed by reports connecting the concern with the diamond house of Chas. F. Wood & Co. against which a bankruptcy petition was recently filed. It should be mentioned that the two firms are entirely different and that they or their members are in no way connected, directly or indirectly, the confusion arising solely through the similarity in the names.

According to the regular monthly statement of the Bureau of Statistics at the Custom House, the following figures of interest to the jewelry trade are published. The figures show the valuation of merchandise remaining in bond at this report for the month of March, 1908, as compared with the same month for 1907: Clocks, etc., \$20,250, as compared with \$30,446 for 1907; diamonds unset, \$60,998, as compared with \$72,381; precious stones, \$33,969, as compared with \$31,550 for the previous year, and jewelry, \$30,174, as compared with \$8,177.

The action at law brought by John Hicks, Long Branch, N. J., against Barnett Daniel, 49 Maiden Lane, to recover the sum of \$163.50 alleged to be due on an account standing since 1904 for jewelry which the plaintiff claimed he sold to Daniel, came up for trial before Judge Spiegelberg in the Eighth District Municipal Court, Tuesday, April 21. The complainant was dismissed and a judgment for a counter claim of \$28.55 and costs was granted to the defendant. Upon the trial it appeared that goods received by Daniel from Hicks were left on memorandum and were either paid for within a short period or returned to Hicks. The defendant was represented by Attorney Milton Hart.

Judge Lacombe, in the United States Circuit Court, handed down an opinion, last Thursday, on the motion to set aside the service of summons in the case of Joseph Irons against the Simeon L. & Geo. H. Rogers Co., in which he denied the motion, but said that if the defendant believed they could show the agent is a mere solicitor who has no power to contract, and will pay the expenses of a hearing before a special master to establish that fact, an order of reference will be made. The suit was brought in the New York Supreme Court and was for alleged breach of contract, and papers were served on R. E. Sage, secretary of the concern on March 13. On April 1 an order to show cause why the service should not be set aside was asked for in the United States Circuit Court. Argument was heard on April 10 and briefs submitted on April 21, Judge Lacombe handing down his opinion Thursday.

Saturday afternoon about 3 P. M. a well-dressed young woman called at the store of William Barthman, 174 Broadway, and succeeded in substituting a ring set with an imitation diamond for a genuine diamond ring without being detected. She said she wished to see some gentlemen's rings, but found nothing that suited her,

and asked to see ladies' rings. In some way she replaced a valuable ring with an exact imitation and the fraud was not discovered until Monday morning. The young woman is described as being about 23 years old, a blonde, about five feet seven inches tall, and weighing about 130 pounds. She was dressed in a light-colored cloth, and acted nervous while pretending to make her purchases. The ring taken was in a Tiffany setting and had a three-carat stone. The woman gave the jeweler her address at an apartment house at 107th St. and Broadway. Inquiry there divulged the fact that a woman known by the name given to the jeweler lived there about eight months ago.

J. R. Deen, who has for the past 12 years been the diamond cleaver for the firms of L. & M. Kahn, Fera & Kadison and J. R. Wood & Son, of this city, returned from Europe about two weeks ago bringing with him an exact model of the famous Cullinan diamond, the Transvaal's gift to King Edward. The diamond is now in the process of cutting, and two pieces have been cleaved from it, one weighing 1,000 karats and the other 250 karats. The first piece cleaved from the diamond removed the slight defect which the stone contained. The diamond originally weighed 3,025 karats, and has now been reduced to 1,775 karats after cleaving. Mr. Deen stated that the stone would weigh about 710 karats when finished. Special machinery and tools are being used in the work, and about a year will be necessary to finish the cutting. The stone is being cut by a Mr. Koe, who is the cutter for the diamond cutting firm of J. Asscher, Amsterdam. The model which Mr. Deen brought with him is the property of the Premier Mining Co., and was loaned by them to him. It was made by an Italian sculptor and is an exact facsimile of the original gem.

Members of the trade of this city are warned to be careful in dealing with a short stout man about 45 years old, who looks like a Hebrew and who offers checks in payment for jewelry. The man has a light mustache and seems to be near-sighted, at least the eyeglasses that he wears would indicate this. On April 1 this man called at the store of D. Bick, 360 Third Ave., and picked out a diamond ring valued at \$50, for which he paid him with a check of \$146 drawn on the Second National Bank of Hoboken, payable to I. Bloom or J. Bloom, and endorsed with that name. He left the check with the jeweler to be certified, saying that he would call on the following Saturday for the ring and the change. Mr. Bick sent the check to the bank, which certified it, but the messenger, being still suspicious, got the name and address of the drawer from the bank and called upon him. This man, who proved to be a saloon keeper, admitted that the signature bore a remarkable resemblance to his own, but said that it was a forgery, stating that he had never drawn a check of this amount to the payee named thereon. Mr. Bick notified the police of the occurrence and waited the arrival of his customer. On April 18, the day he was due to come for the ring, he did not appear, but telephoned that he would send

1851

The Jeweler's Bank for half a century
In the same location

1908

THE CHATHAM NATIONAL BANK

Broadway and John Street, New York

ACCOUNTS INVITED

GEORGE M. HARD, President

FRANK J. HEANEY, Vice-President

WILLIAM H. STRAWN, Cashier

C. H. IMHOFF, Vice-President

HENRY L. CADMUS, Assistant Cashier

Title Guarantee and Trust Company

176 Broadway (between John St. & Maiden Lane)

NEW YORK

Capital and Surplus, \$12,000,000 :: The Depositor's best guarantee is a large capital and surplus, together with conservative management

TRUSTEES

John Jacob Astor, 23 West 26th St., New York
 Frank Bailey, Vice-President
 E. T. Bedford, President Corn Products Refining Co.
 Charles S. Brown, of Douglas Robinson, Charles S. Brown & Co.
 Julien T. Davies, of Davies, Stone & Auerbach
 William M. Ingraham, Attorney-at-Law, 44 Court St., Brooklyn
 Augustus D. Juilliard, of A. D. Juilliard & Co.
 Martin Joost, Vice-President Bond & Mortgage Guarantee Co.
 Clarence H. Kelsey, President
 John S. Kennedy, Retired, 31 Nassau St., New York
 Woodbury Langdon, of Joy, Langdon & Co.
 James D. Lynch, Retired, 129 East 21st St., New York
 Ronald H. Macdonald, of R. H. Macdonald & Co., Real Estate
 James H. Manning, President National Savings Bank, Albany
 Edgar L. Marston, of Blair & Co.

Wm. J. Matheson, of W. J. Matheson & Co., 182 Front St.
 Charles Matlack, 70 State St., Boston
 William H. Nichols, Chairman of Board, General Chemical Co.
 William A. Nash, President Corn Exchange Bank
 Robert Olyphant, of Ward & Olyphant
 Charles A. Peabody, President Mutual Life Insurance Co.
 William H. Porter, President Chemical National Bank
 Frederick Potter, 71 Broadway, New York
 Charles Richardson, 1307 Spruce St., Philadelphia
 Henry Roth, 1562 Myrtle Ave., Brooklyn
 Jacob H. Schiff, of Kuhn, Loeb & Co.
 James Speyer, of Speyer & Co.
 Sanford H. Steele, of Steele, Onis & Hall, Attorneys
 Ellis D. Williams, 560 Drexel Bldg., Philadelphia
 Louis Windmuller, of Louis Windmuller & Roelker

BRANCH BANKING OFFICES 196 Montague St. and 175 Remsen St., Brooklyn; 350 Fulton St., Jamaica; 67 Jackson Ave., Long Island City

The Market and Fulton National Bank of New York

ORGANIZED 1852

81-83 FULTON STREET

Capital, \$1,000,000

Surplus, \$1,500,000

PROGRESSIVE—CONSERVATIVE—SUCCESSFUL

ALEXANDER GILBERT, President
 R. A. PARKER, Vice-President
 T. J. STEVENS, Cashier
 JOHN H. CARR, Asst. Cashier

Invites the Accounts of Jewelers

Will extend every facility that good banking will justify

SAFE DEPOSIT VAULTS

THE STATE BANK

376-378 GRAND STREET, NEW YORK

Capital and Earned Surplus, over \$1,500,000. Deposits over Fifteen Millions.

Offers a favorable market for short and long time jewelry and diamond paper.

The Silversmiths Building

15-17-19 MAIDEN LANE

EDWARD HOLBROOK, President

☞ Location unsurpassed. ☞ In the center of the jewelry and silverware trade, not only in this city but this continent. ☞ Magnificent views from the upper stories of the North and East Rivers, new bridges and general view of the Island of Manhattan. ☞ Occupied exclusively by the jewelry, silverware and kindred trades. ☞ This building has been largely advertised by the owners and that in turn is now being taken up by the tenants not only in this country but in Europe.

Tenants Now Moving In



We beg to announce that the Rental Office of the Maiden Lane Realty Company is now permanently located in the Silversmiths Building.

PLANS AND FULL PARTICULARS
FURNISHED UPON APPLICATION



GROSS AND GROSS COMPANY
MANAGERS

COURTLAND E. HASTINGS, Agent

OFFICE IN ARCADE

TELEPHONE: 7493 CORTLAND

New York Notes.

(Continued from page 73.)

a messenger for the diamond. The jeweler said that he would not trust a messenger, and that the customer must come himself. The man has not since appeared at the jewelry store for his ring, his change or the check. The detectives who received his description think the man is an old offender, who has been previously arrested on a similar charge.

Alfred Lindenbaum, of Lindenbaum & Weil, Paris, France, is in this city on his first visit.

S. D. MacPherson, of MacPherson, Roubaud & Co., Providence, R. I., sailed recently on the *Oceanic*.

L. Abrahams, head of the London diamond syndicate, returns to Europe on the Cunard liner *Lucania* to-day.

H. J. Hooper, jewelers' auctioneer, is holding a successful sale, closing out the stock of Otto Jarek's, Easton, Pa.

Max Arnstein, of Arnstein Bros. & Co., 65 Nassau St., accompanied by his family, will sail on the *Deutschland* to-morrow.

The engagement of M. Dreicer, of Dreicer & Co., to Miss M. Schainwald, is announced. The marriage will take place May 20.

Irving Cohn, of M. J. Averbeck, 10-12 Maiden Lane, started Saturday for a two weeks' trip for that concern through New York State.

Morris Lissauer, of the firm of Zach A. Oppenheimer, 68 Nassau St., is now in Europe. He sailed on the *Kronprinzessin Cecile*, April 14.

The Untermeyer-Robbins Co., 71 Nassau St., has since the first of the month reinstated its full force of employes and the factory is now running on full schedule time.

The prize cup offered for the Briarcliff automobile race last week was made by Tiffany & Co. It was donated by Walter W. Law, Briarcliff Manor, Westchester County.

John Wiener, diamond cutter, 37 Maiden Lane, reports that he has no intention of moving his place of business. The report that he was going to do so resulted from friends confusing his name with that of another Wiener.

A father and two sons were locked up in Police Headquarters Friday, charged with having threatened death to a witness in a case now on trial in Part IV., General Sessions. The prisoners are Carmela Giannone and Michael Giannone, jewelers, of 81 Oliver St., and Cologero Giannone, a photographer.

The Standard Jeweled Bearings Co. has been incorporated, under the laws of New York State, to manufacture and deal in jewels for electrical and mechanical purposes, precious stones, jewelry, etc., with a capital of \$5,000. The incorporators are William Houser and Louis Levy, New York, and Catharine F. Calahan, Brooklyn.

Among the members of the "Asahi" round-the-world touring party of prominent Japanese who were in this city last week were K. T. Kitade, a jeweler of Osaka, and Mr. and Mrs. Y. Hori. Mr. Hori is also a jeweler in the same Japanese city.

The party sailed on the White Star liner *Cedric* for Liverpool, Eng., last Thursday.

A petition in bankruptcy was filed in the United States District Court, New York, Monday, by Daniel Offenhütter, diamond setter, 12 John St., New York, with schedules showing liabilities of \$3,204 and nominal assets of \$150, consisting of tools, safes and fixtures. Among the unsecured creditors are Oppenheim & Strauss, about \$2,000; Davidson & Appel, \$260; Goldmuntz Bros., \$380, and Mr. Langer, about \$350.

Judge Holt, of the United States District Court, has confirmed a composition of Adolph L. Hodes, wholesale jeweler, 65 Nassau St., with his creditors at 50 cents on the dollar, payable 10 cents cash, 10 cents notes at four months, 10 cents notes at eight months, 10 cents notes at 12 months and 10 cents notes at 16 months. He filed a petition in bankruptcy on Jan. 30, with liabilities \$46,100 and assets \$32,268.

The directors of the Gorham Co. have declared a quarterly dividend of 1½ per cent. and 1 per cent. extra on the common stock, payable May 10. The stock has been on a 10 per cent. annual basis for some time past, but the custom hitherto has been to pay 1½ per cent. quarterly and an extra dividend of ¼ per cent. for the last quarter of the year. This arrangement equalizes the payments instead of having a dividend of ¼ per cent. for the last quarter of the year.

Judge Hough, in the United States District Court, has appointed Fred J. Moses receiver in bankruptcy for the American Sheffield Silver Co., manufacturers of silver plated ware, First Ave. and 28th St., under a bond of \$2,000. A petition in bankruptcy was filed against this concern last week. It was stated that the plant and machinery are covered by a chattel mortgage for \$6,000. It is also alleged that the raw material and unfinished product valued at several thousand dollars has been removed.

At a recent meeting of the Jewelers Board of Trade amendments to the by-laws were adopted by adding to section 2 of Article IV. a new paragraph establishing a "good and welfare" committee to be appointed by the president and serve for one year. Article IV. was amended by changing section 16 to section 17 and adding as section 16 a clause which states that the good and welfare committee shall, with the approval of the board of directors, take cognizance of all such objects for which the organization is formed as are not under the care and supervision of the other standing committees.

Mrs. Mildred Garner is under arrest in Newark for having obtained, with worthless checks, diamonds valued at \$2,000, from Dreicer & Co., 560 Fifth Ave., this city. She confessed that she has a police record. She will be arraigned in Newark on an indictment charging her with having also given P. B. Levy & Co., of that city, a worthless check for \$146 in payment for jewelry. At the store of Dreicer & Co. it was said that the woman came there on a Saturday, after banking hours, and presented a check for the goods which she desired. When she went to the store on April 12, Mrs. Garner represented that she had dealt for years with a Mr. Kelly, formerly a salesman for the house, who

died last November. She seemed much affected when told of Kelly's death, and thus threw the manager of the house off guard. It was said at the Dreicer store that most of the goods had been recovered.

Diamonds of Various Colors.

THE mention of the word "diamond" immediately brings to mind the picture of a translucent, white gem, but all diamonds, however, are not white. The most beautiful of all precious stones is said to be the red diamond. This surpasses the ruby in beauty and is exceedingly rare. A few specimens are known to exist, one which, weighing 10 carats, now in possession of the Emperor of Russia, was bought by Emperor Paul for \$50,000.

Dark blue diamonds, differing from sapphires only in quality and luster and in the beautiful play of colors peculiar to the diamond, are handsome gems. Besides the Bismarck and Hope diamonds, there are only two known specimens in the world that can properly be called blue diamonds. Black and rose-colored diamonds are also rare, while green varieties are not so uncommon. The grass green is scarce, and when it does occur it is more brilliant than the finest emerald. There are several varieties of green-tinted diamonds at the Museum of Natural History at Paris.

The most perfect collection of colored diamonds is in Vienna. It is in the form of a bouquet, the different flowers being composed of diamonds of the same color as the blossoms represented. These stones were collected by Vergil von Helmeicher, a Tyrolean, who had passed many years in Brazil among the diamond mines. E. F.

"Jade."

JADE, a stone nearly allied to the jasper, has come again into fashion after years of desuetude. It is a remarkably hard, opaque lapis, of waxy appearance, and a greenish olivaceous or grayish hue, requiring the assistance of diamond dust to polish it, and retaining after the process only an imperfect, greasy appearance. Its extreme hardness has caused it to be used by the East Indians for hatchet heads.

The modern Hindu lapidaries work it up into various bijoux and form rings of it. In modern jewelry owls and little dogs, apes and insects of strange shape are made of it and mounted in gold. There are many mediæval antiquities in which jade figures—thumb rings and *bas reliefs* and cinquecento vases.

Jade has a very stylish appearance as an ornament; it is translucent in a strong light. It was used but sparingly in ancient intaglios, on account of its hardness, and has always been very expensive.

Thieves recently forced their way into the retail jewelry store of the Amussen Jewelry Co., 70 S. Main St., Salt Lake City, Utah, and escaped with about \$480 worth of gold rings and watch chains. The building which the concern occupies is in process of destruction, the concern having decided to vacate the premises. The thieves took advantage of the partly razed structure to effect an easy entrance.



Among the traveling representatives looking for business in Toronto, Ont., last week, were: S. B. Skinner, S. Sternau & Co.; R. McKay, Parker Clock Co.

Among the traveling representatives in San Francisco, Cal., during the past week, were: E. C. Binder, Ernst Gideon Beck; Henry Jacobson, Jacobson Bros.; Rosenberg, Alling & Co.; Joseph Aker, Mauser Mfg. Co.; Herbert Brashman, Jos. Fink & Co.

Traveling representatives in Los Angeles, Cal., recently, include: R. Bernhardt, Dorrance-Batten Co.; Joseph B. Tucker, W. E. Graves; O. F. Samuelson, Towle Mfg. Co.; J. F. Finley, Whiteside & Blank; M. Guntzberger, Isidor Guntzberger & Son; L. A. Eppenstein.

The following traveling representatives were in Lancaster, Pa., recently: C. G. Walker, Pairpoint Corporation; J. D. Varley, Allsopp Bros.; Frank G. Mildenberger, J. B. Bowden & Co.; Mr. Van Olinda, New England Watch Co.; Gus Engelsman, Zach. A. Oppenheimer, Mr. Andrews, Andrews Refining Co.

Among the traveling representatives who visited Savannah, Ga., recently, were: George S. Foster, F. A. Hardy & Co.; A. C. Motteran, Frank M. Whiting & Co.; Irving T. Clark, Reed & Barton; E. V. Bogart, Dennison Mfg. Co.; M. L. Barnard, Larter & Sons; Jerome M. Lissauer, Arnstein Bros. & Co.; H. H. Day, Day, Clark & Co.

Representatives of manufacturers in Chicago, last week, were: George Goldberg, Charles Keller & Co.; Fred. Perry, F. H. Sadler Co.; Leo Gahn, F. De Simone & Son; Montague Mendoza, Van Dusen & Stokes Co.; Joseph Rifkin, L. Heller & Sons; C. Fred. Monroe, George M. Baker Co.; Julius Ambruster, Illinois Watch Co.

The following traveling representatives called on the trade in Kansas City, Mo., during the past week: T. W. Agnew, New Clock Co.; W. R. Cobb, W. R. Cobb & Co.; E. J. Hiller, Sussfeld, Lorsch & Co.; Emil Pick, Hammel, Riglander & Co.; Robert E. Kehl, F. H. Noble & Co.; William A. Lamb, George Fuller & Son; Jake Levin, Martin, Low & Taussig.

Traveling representatives in Omaha, Nebr., during the past week, included: A. R. Weise, Illinois Watch Co.; H. L. Schapiro, Goldman Bros.; Chas. Hanni, Sussfeld, Lorsch & Co.; E. B. Frank, Pairpoint Corporation; L. C. May, Moskowitz Bros.; George D. Laurence, Reed & Barton; Fleetwood Lanneau, R. Blackinton & Co.; M. S. Greenbaum, Wm. I. Rosenfeld; F. J. Reynolds, Jennings Bros. Mfg. Co.; S. K. Jonas; James R. Palmer, Henry A. Kirby; Charles E. Bride, Bride & Tinkler; Horace G. Smith, Shepard Mfg. Co.; T. W. Friedman; Mr. Hartshorn, Kremenzt & Co.; H. C. Ulmer, Kryptok Co.; Mr. Weidlich, Weidlich Bros. Mfg. Co.

Traveling salesmen visiting Boston, Mass., during the week, included: William Matschke, A. Joralemon & Son; Arthur Cope, International Silver Co.; Benjamin F. Grisco, Bippart, Grisco & Osborn; V. L. Burgess, Kremenzt & Co.; Mr. Sansbury, Sansbury & Nellis; H. E. Slater, Whiteside & Blank; R. W. Simpson, Riker Bros.; Gus Henckel; A. M. Hill, Jr., Hill & Schmidt; Charles T. Dougherty, Osmer-Dougherty Co.; Arthur Connett, Link & Angell; E. W. Martin, Martin-Copeland Co.; Anson D. Manning, D. Wilcox & Co.; Archie Rutherford; Mr. Thornton, H. A. Kirby; Frank Locklin, Battin & Co.; Ed. Egfeldt, Egfeldt & Aekley; Wallace Campbell, Day, Clark & Co.; L. E. Garrigus, L. E. Garrigus & Co.

The trade at Pittsburg, Pa., was, last week, visited by the following traveling representatives: W. V. Laurino, Saunders, Meurer & Co.; E. A. Reed, Reed & Barton; M. Decker, Plainville Stock Co.; H. C. Hance, J. D. Bergen Co.; L. E. Powell, S. O. Bigney & Co.; Harry E. Berdan, Gorham Co.; Joseph J. Sideman, Redlich & Co.; Mr. Crane, Mandeville, Carrow & Crane; Leopold Heyman, Stern Bros. & Co.; C. B. Bartlett, Whiting Mfg. Co.; David S. Jacobs, Wagner Comb Mfg. Co.; M. Untermeyer, Chas. Keller & Co.; Mr. Curran,

A. J. Hedges & Co.; Mr. Bliss, Wordley, Allsopp & Bliss Co.; A. E. Silberman, Adolphe Schwob; H. B. Rogers, Rogers & Co.; George W. Beardley, Allsopp & Allsopp; S. E. Coggins, Towle Mfg. Co.

The traveling representatives who called on the Cincinnati, O., trade, during the past week, included: W. S. Metcalf, Plainville Stock Co.; Harry H. Miller, Hutchinson & Huestis; Mr. Moore, Moore & Son; I. S. Richter, Doran, Bagnall & Co.; H. B. Matthews, Matthews Co.; E. A. Reed, Reed & Barton; J. T. Griffith, Jr., Carter, Howe & Co.; Alfred Goldsmith, L. D. Bloch & Co.; D. A. Davidson, Wallach & Davidson; Thomas E. Rogers, Kiker Bros.; Jack Thompson, J. B. Bowden & Co.; W. C. Barry, Larter & Sons; Charles L. Miller, Ansonia Clock Co.; W. S. Dudley, Rogers, Smith & Co.; W. S. Mannheim, Louis Mannheim & Bros.; Ernest Block, Louis Stern & Co.; J. B. Macdonald, Wolcott Mfg. Co.; Theodore Parker, Smith & Crosby; T. K. Benton, Geo. W. Parks Co.

Canada Notes.

The stock of John A. McMillan, Red Deer, Alberta, has been sold by the sheriff.

The *Jewelers Journal* has been amalgamated with the *Trader and Canadian Jeweler*.

O. J. Faillon, son of E. Faillon, of the E. Faillon Jewelry Co., Fort William, Ont., has been taken into the firm, which will now be known as Faillon & Son.

William McGirnsie and William Martin, of Kenora, Ont., have purchased the jewelry business of T. D. McEachren, Fort William, Ont., which they will conduct under the firm name of McGirnsie & Martin.

A quantity of the jewelry stolen from the store of B. A. Griffith, Hagersville, Ont., April 3, was recently found by the detectives hidden in the bush three miles from the town. The burglary is now supposed to have been the work of tramps.

On Saturday, April 11, the jewelry store of Joshua Shapiro, 57 Bleury St., Montreal, was robbed of five gold-filled watches by some man who entered while the proprietor was in the rear apartment and opened the show case, escaping without detection.

The jewelry store of Moses Goldstein, Rideau St., Ottawa, was entered at midnight, April 16. A policeman saw a man go into the store, the door of which, a few minutes before, had been locked, and arrested him before he had taken anything. He gave the name of Gustave Anderson and stated that he was a Norwegian and had been three years in Canada. On Thursday he was tried and sentenced to one year's imprisonment.

Out-of-town jewelers calling on the Toronto, Ont., trade last week included: Joseph Pequegnat, Guelph; Geo. Hynds, Acton; Henry Wendt, Clifford; W. F. McCarty, Lindsay; Chas. Wendt, Mildmay; O. Milburn, Peterborough; A. Neilly, Bradford; R. Robertson, Hagersville; I. Whitesmith, Manilla; W. H. Herchmer, Bobcaygeon; G. H. O. Thomas, Bracebridge; J. Thomas, North Bay; G. H. Hewson, Bayfield; W. H. Hellyer, Clinton, and J. W. Shales, Mount Forest, all Ontario.

W. K. McNaught, M.P.P.; Thomas Roden and W. G. Ellis, Toronto, representing the manufacturing jewelers; Walter J. Barr, Toronto, and Adolphe Levy, Hamilton, representing the wholesale trade, and E. M. Trowen, secretary of the Retail Merchants' Association, representing the retail jewelers, left for Ottawa, Thursday night, to interview the government regarding the proposed amendments to the Gold

and Silver Marking Act. They will be joined by deputations of the trade from Montreal and Ottawa.

Henri Pinault, Hull, Que., was arrested and brought before the magistrate on Monday, April 20, charged with buying stolen jewelry to the value of \$800. Many of the articles found in his store were identified as having been stolen from parties in Ottawa. Pinault claimed that he had purchased the jewelry from a man he did not know at intervals from September until February last. Pinault has hitherto borne a good reputation and his business was apparently a prosperous one. The case was not concluded at last accounts.

Harry C. Bradley, Windsor, is defendant in a somewhat peculiar action brought by his sister, Miss Susan Bradley, of Toronto, who claims \$6,000 damages for breach of contract. She alleges that at the time of Mrs. Bradley's death, about 12 years ago, she gave up her position as a dressmaker to go to Windsor and act as her brother's housekeeper on condition of his agreeing not to marry again and to provide her with a permanent home. Six months since Bradley took a second wife and his sister now asks damages for breach of the agreement, or otherwise wages for her services as housekeeper for 12 years at \$500 per year.

Newark.

R. S. Schindel & Co., East Orange, dealers in jewelry and precious stones, have been incorporated under the laws of the State of New Jersey, with a capital stock of \$2,000. The incorporators are: K. S. Schindel, Charles O. Gayer and Frank C. Ferguson.

Emil Fiess' jewelry store, at 27 Main St., Paterson, N. J., was entered by thieves Wednesday night. Twenty-one watches, valued at \$2 each, and a number of revolvers were taken. It is believed that there were a number of men concerned in the job. The theft was reported to the police Thursday morning.

A messenger employed by Allsopp & Allsopp, manufacturing jewelers, 18 Columbia St., lost a package containing a valuable diamond and sapphire bracelet on the street a few days ago. Anyone finding the same or hearing of it being found is requested to notify THE JEWELERS' CIRCULAR-WEEKLY or Allsopp & Allsopp.

William Russell Tarbor, of New York, has bought the factory and machinery of the Trenton Watch Co. at the public auction under foreclosure proceedings. The price paid was \$50,010. The mortgage satisfied was one of \$100,000 of bondholders, for whom the Trenton Trust and Safe Deposit Co. is trustee. The proceeds of the sale will be divided among the bondholders, the payments being about 50 per cent. of their claims, except to the banks, which will lose little, as they are protected by collateral securities. The purchaser is a stranger in Trenton, N. J., and he declined to talk as to the use he would make of the factory. It is believed that he represents one of the large watchmaking concerns and that the plant will again be operated.

S. Mitchell has purchased the jewelry and drug business of A. A. Guibert, Waterville, Wash.

Philadelphia.

The Philadelphia Horological Club holds its next meeting at Soulas' to-morrow, April 30.

A. F. J. Dorn, 834 Market St., Camden, N. J., has returned from a pleasure trip of a few days to New York.

John Lohmeyer, watchmaker with D. Wolff, 909 Vine St., is at Atlantic City recuperating from a recent illness.

Watchmakers of this city express deep regret at the death, recently, of Wm. Trippen, watchmaker, formerly with Wm. Moore, 1728 Ridge Ave.

Albert McKinney, watchmaker, resigned his position last week with H. Lippman, 52d and Haverford Ave., to accept a place with H. Davis, 52d and Market Sts.

Isadore B. Braverman, a bankrupt Reading, Pa., retailer, applied to the United States District Court in this city last week for his discharge from bankruptcy.

Herman Kruse, watchmaker, resigned his position last week with Blair & Crawford to go with the Bailey, Banks & Biddle Co., by whom he was formerly employed.

The J. S. Sandoz Co., of this city, was granted a charter of incorporation under the State laws of Delaware last week to manufacture watches. The capital is stated to be \$100,000.

The show window of the watchmaker's shop of J. B. Tashian, 5127 Laneaster Ave., was burned out by a fire apparently started by the carelessness of a smoker last week. The loss amounted to \$75.

James Blisard, of John F. Blisard & Co., is receiving the felicitations of his friends in the trade, who became aware last week that the stork had visited the Blisard household and left a charming baby girl.

The man who recently attempted to steal a \$150 ring from R. Pinkstone's store, 20th and South Sts., but who was captured after an exciting chase by Wesley Reid, the colored porter, was last week sentenced to an imprisonment of one year.

E. L. Thomas, Phoenixville, Pa., recently completed the building of a new automobile which he started to use last week for pleasure trips and for his own convenience. Mr. Thomas now makes his visits to the local wholesale trade in his auto.

By order of Edwin V. Brown and William Morris, receivers of the bankrupt estate of George Mayer & Co., wholesale opticians at 728 Sansom St., the entire stock and fixtures of the plant will be sold at auction Tuesday, May 5, at 10 a. m.

Price & Keene, opticians, 1211 Walnut St., dissolved partnership last week. They have been in business there about five years and were formerly with Queen & Co. The business will be continued hereafter by Charles Keene, under the name of Price & Keene.

Title to the old watch factory of H. Muhr's Sons, at Broad and Race Sts., passed last week from John Wanamaker, its latest owner, to the Philadelphia Consistory of the Scottish Rite Masons, which will replace the factory building with a temple.

Col. J. Warner Hutchins, president of the Jewelers' Club; D. V. and Andrew Brown, and David C. Clegg attended the banquet given Saturday night in honor of United

States Senator Philander C. Knox, who was boomed as Pennsylvania's presidential candidate.

L. Breitingger, president of the American Cuckoo Clock Co., is rejoicing over the arrival of a bouncing baby boy at his home on Easter morning. This is the first born, and Mr. and Mrs. Breitingger have been the recipients of many congratulations from their friends in the trade.

A. G. Lee, with the Howard Watch Co., was in this city a few days last week renewing old acquaintances in the trade, having just returned from an extended and successful trip through the west. Mr. Lee departs this week for a trip to New England. A cordial reception was given him in this city.

Bids for furnishing silverware and cutlery for the United States army will be opened May 21 at the Quartermaster's office, 26th St. and Gray's Ferry Road, according to an announcement made last week by Lieut. Col. F. G. Hodgson. Bids from all sections of the country are expected since the contract is usually regarded as a profitable one.

Miss Rubenstone, formerly in partnership with her uncle, Jacob Rubenstone, manufacturing jeweler, 125 S. 7th St., recently disposed of her interest in her uncle's business, in which she has for years been actively connected, and accepted a position as assistant buyer and manager of the jewelry department of N. Snellenberg & Co.'s department store.

J. A. Schmidt and George Hunt, formerly with I. Eiseman, manufacturing jeweler, Pittsburg, whom they accompanied to that city when he removed his establishment there from Sansom St., near 7th St., this city, returned here last week, having resigned their positions. Both contemplate accepting positions with a large New York manufacturing jeweler.

The Hoover & Smith Co., 616 Chestnut St., was awarded the contract recently for the furnishing of gold watches and silver tankards to the number of about 200 awarded at the annual relay races under the auspices of the University of Pennsylvania, held Saturday at Franklin Field. The prizes were displayed in the show window of Perry's store, at 17th and Chestnut Sts., where they attracted much attention and favorable comment.

I. Press & Son, retail jewelers, began last week the extensive remodeling and alteration of their stores, 33 and 33½ S. 8th St. The stores, one of which was until recently occupied by Robert McCullough, who disposed of his business, will have one long front bulk window and will be made one store. They will be made into one of the most attractive stores on S. 8th St. I. Press & Son conduct stores also on N. 8th St., near Race, and on S. 2d St., the latter being the parent store.

The Philadelphia Jewelers' Club gave a smoker and vaudeville entertainment for its members, and their friends and guests at the club headquarters, 1228 Chestnut St., last night, after THE CIRCULAR-WEEKLY had gone to press. A full report of the entertainment will be made in the next issue. Many out-of-town retailers and traveling men attended last night's smoker, and altogether about 200 guests were present.

The talent furnished was of the best and between songs, displays of legerdemain, monologues, etc., the members and their guests found lots to amuse them. A buffet supper was served.

John B. Clark, for 15 years a trusted employe of Simons, Bro. & Co., was arrested Thursday last charged with having systematically stolen from his employers' workshops and having disposed of silver to secure money to purchase drink. At a hearing before Magistrate Beaton he was held in \$800 bail for a further hearing April 30. In the meantime detectives will be at work on the case to endeavor to ascertain the extent of Clark's alleged peculations, which are believed to have been about \$1,000. The firm has been missing silver for about a year. Clark was suspected of having taken the metal and was discharged from their employ.

One of the principal figures in the magnificent celebration of the centenary of the founding of the Catholic diocese of Philadelphia in this city last week, which was participated in by dignitaries of the Catholic Church from all parts of the world and by distinguished members of the laity, was Z. J. Pequignot, a prominent retail jeweler of Walnut St., near Broad St. Mr. Pequignot, who is president of the Society of St. Vincent de Paul, which tendered a reception to Cardinal Gibbons, Archbishop Ryan, the other archbishops, Apostolic delegate, monsignorie and prelates, was chairman of the committee on arrangements. He was active also on other occasions marking the centenary.

Ernest D. Sturmer, general manager of Lyons & MacPherson's store at Tamaqua, Pa., stopped off in this city for a few days last week as the guest of his brother, State Senator George Sturmer. Oscar F. Sturmer, formerly a prominent retail jeweler of Easton, Md., who met his death by falling into the Susquehanna river from a train on which he was a passenger while crossing near Havre de Grace, Md., was buried Thursday. A coroner's jury rendered a verdict of accidental death. Ernest Sturmer left this city to take temporary charge of his brother's store in Easton, Md., and says he will take over the business and conduct it permanently if it proves profitable. The dead jeweler was unmarried and his estate will be distributed among brothers and sisters.

Two handsome silver centerpieces and a magnificent trophy were exhibited in the show window of Bailey, Banks & Biddle Co. last week. One was the Bermuda Challenge Cup presented by James Gordon Bennett, to be competed for in the motor boat race from New York to Bermuda in June of this year. It stands about three feet high, and is of gray finished silver on an ebony base. Its design comprehends an etching of a yacht insignia of yachting and a space for an appropriate inscription. One centerpiece was for presentation to Col. Theodore E. Weidersheim by the Veteran Corps of the First Regiment, N. G. P. The regimental colors and an etching of a private soldier decorate it. The other centerpiece, which includes a silver plateau, is for presentation to the Rev. Chas. Wood, D.D., a distinguished clergyman.

Baseball enthusiasts in the Philadelphia

wholesale trade organized last week the Philadelphia Jewelers' baseball nine, with Harry W. Smith, lapidist, 711 Sansom St., as manager, and will play each Saturday afternoon with such nines of other trades or associations as they can secure matches with. The best baseball players in the trade are being recruited to form a formidable aggregation and the jewelers expect to make such a record as will make the trade proud of them. The first game was played at Logan Station Saturday with the Logan Guild. The jewelers lined up as follows: William Doebele, c.; Remy, p.; W. C. Robertson, lb.; Stoughton, 2b.; H. W. Smith, ss.; B. F. Krisher, 3b.; Fred Smith, lf.; Walter Warner, cf.; Faul, rf., and Eisenhart, c. All applications for membership in the association or for games should be made to Manager Harry Smith.

News Gleanings.

F. L. Wilson, Danbury, has joined the ranks of the automobilists.

C. H. Coles, formerly of Sandwich, Ill., has moved to Gainesville, Fla.

Howard J. Hood, Ozark, Ala., has been succeeded by R. F. & E. W. Paddison.

Harry H. Hovey has purchased the business of L. Anderson Sands, Ortonville, Mich.

Ralph Campbell, Westphalia, Kans., has sold his business to P. J. Tonjes, Linn, Kans.

Mitchel Dumas, Jr., Southbridge, Mass., has been succeeded by Mitchel Dumas, Jr., & Co.

Klar & Cross is the name of the business formerly conducted by John Klar, Hillsboro, Ill.

Crofut & Garland, Malta, Mont., have dissolved, Edwin E. Crofut succeeding to the business.

S. H. Patterson, formerly with Sunderlin & Co., is now watchmaker for Nelson A. Soggs, Rochester, N. Y.

John A. Stapf, Jr., Dunkirk, N. Y., and Miss Mildred E. Wolfers, of Fredonia, were recently united in marriage.

Beasley & Eggleston, Fayetteville, N. C., have dissolved partnership, B. F. Beasley continuing the business on his own account.

James E. Swarthout & Co., Elmira, N. Y., have been awarded the contract to supply the silverware to the new Hotel Rathbun, at that place.

C. J. Kortman, Madison, Nebr., was hurriedly called to Charter Oak, Ia., last week, on account of the illness of his sister, who is now much better.

Sam Martin, 205 Farwell Ave., Milwaukee, Wis., has just closed a successful nine weeks' auction for the M. Scooler Co., of New Orleans, La.

A receiver's sale is now in progress at the store of Parker, Kolb & Co., Bridgeport, Conn., under the management of Dwight A. Parker. The business is still being continued.

A fire started at midnight about a week ago in the basement under the store of Edward Bengston, Freeport, Ill., and was extinguished before doing any extensive damage.

The Parritt Jewelry Co. has been incorporated in Des Moines, Ia., with a capital stock of \$50,000. F. T. Parritt is president

and J. H. Merrick secretary of the concern.

The Jos. Welf & Sons Co., Cleveland, O., has been awarded the contract to supply a town clock to Chardon, O. The timepiece will be installed in the Court House tower, at that place.

The Rhode Island Mfg. Co., Iowa City, Ia., will move to Cedar Rapids, in the same State, May 1. The officers of the firm are: President, Nicholas Zeller; secretary, O. Zeller; manager, S. G. Duley.

Oren Martin, an itinerant jewelry vender, residing in Newton, N. J., died suddenly in Mase Mountain, near Dover, last Thursday. Death was caused by heart disease. The deceased was about 50 years old.

President Foster E. Harvey, of the Hartford Business Men's Association, Hartford, was one of the representative speakers at a celebration by the town of Stafford on the occasion of the opening of its trolley line, April 20.

Alonzo Sturgell and Bascom Sturgell, who conducted business as Sturgell Bros., Tuscola, Ill., have dissolved. Alonzo Sturgell will continue at the old address, while Bascom Sturgell will move to Robinson, Ill., where he will succeed to the business of Seitz Bros.

Theo. Ernst, a well-known jeweler of Fort Madison, Ia., celebrated, last Saturday, the 61st anniversary of his first day at learning the watchmaker's and jeweler's trade, which he began as a lad in Germany. Mr. Ernst has been a citizen of Fort Madison since 1861, all of the time working at his trade and conducting a jewelry store.

Miss Ray L. Bowman, engaged in the retail jewelry business in Champaign, Ill., has the sympathy of her many friends in the trade, owing to the recent death of her mother, Mrs. Mary A. Bowman, who died at her daughter's home, 307 S. Prairie St., Tuesday of last week, aged 81 years. The deceased had made her home with her daughter for the past 30 years.

With elaborate ceremonies a handsome Colonial hall clock was presented to the National Society of the Daughters of the American Revolution Wednesday last. The timepiece, which was given by the Berks County Chapter of Reading, Pa., is valued at \$500, and will occupy a prominent place in the Memorial Continental Hall, where the congress of the national society was held last week.

Joseph Levesque was before Judge Reed at Brockton, Mass., last week, charged with the larceny of rings and watches valued at more than \$100 and also to answer to a complaint alleging the uttering of a forged contract of sale. In each case the court found probable cause and ordered the defendant held in \$300 bail for the Grand Jury. The defendant was engaged as a salesman for a Brockton jewelry house.

Word was received recently of the death of Morton Phillips Levy, for many years connected with the M. Scooler Co., of New Orleans, La., and widely known to the jewelry trade of the south. Mr. Levy died in New Orleans, April 18, in his 40th year. He had been ill for a long time and his death, while not unexpected, was a great blow to his relatives and many friends in the jewelry trade. Mr. Levy is survived by his mother, four sisters and three brothers.

A dispatch from Beardstown, Ill., recently stated that the largest fresh water pearl taken out of the Illinois River since the work of pearl hunting commenced last Spring, was the one found April 16 by Everett Bros. The pearl weighed 52 3/4 grains and is a perfect sphere, has a translucent white color with an iridescent sheen such as is usually found only in smaller specimens, and it is without a speck or flaw. It is considered by locals as a "pearl of the first water."

Among the well-known concerns of the trade which have forwarded subscriptions to First Assistant Gardner to defray the expenses of the annual ball of the Wallingford Fire Department, which was held in the armory in Wallingford, Conn., Friday evening were: Factories "M" and "L," International Silver Co., \$40; R. Wallace & Sons Mfg. Co., \$25; Factory "P," International Silver Co., \$15; H. L. Judd Co., \$25; S. L. & G. H. Rogers Co., \$5; Biggins-Rodgers Co., \$5.

A well dressed young man, calling himself L. H. Berg, and saying that he represented a wagon company of Chicago, called at the store of E. B. Roser, Wellington, Kans., Wednesday last, and endeavored to obtain a loan of \$350 from the jeweler, offering as collateral some showy diamond jewelry of inferior quality. The man claimed that he owed \$500 to a Chicago bank and that they were pressing him for money, and if the jeweler would let him have \$350 on the articles he offered he would redeem them for \$400 in a couple of weeks. One piece offered was a bracelet with seven stones and another a locket with the same number of gems. The diamonds were of very inferior grade but were set in a way that covered up their defects. As Mr. Roser believed the man was making a practice of offering stuff of this kind to the jewelers he immediately notified THE CIRCULAR-WEEKLY that we might in turn warn our subscribers. A letter from a Chillicothe, Mo., jeweler indicates that the same man was in that town offering articles as collateral for a loan.

Market Price of Silver Bars.

The following are the quotations of silver bars in London and New York, as reported by Zimmermann & Forshay:

	London.	New York. 999 Basis.
April 21.....	25 3-16d.	.56%
" 22.....	25 3-16d.	.56%
" 23.....	25 1-16d.	.56%
" 24.....	24 7-8d.	.56
" 25.....	24 11-16d.	.55 1/2
" 27.....	24 9-16d.	.55%

A new upright portable electric motor drill recently marketed by the W. Green Electric Co., 81 Nassau St., New York, deserves the most careful investigation on account of its universal utility in all branches of mechanical industry. Its use is recommended to opticians, lapidaries, jewelers, horologists, dentists and in all laboratories for the manufacture of small appliances. The new device, it is claimed, has many advantages, and is intended to take the place of obsolete methods limiting space, and where quick, accurate and high-class work is desired. It can be used with a direct or an alternating current.

The Unequaled



No. 16398

Can be Procured
From the Jobber
For \$1.00

“Mary Stuart” Bracelet

Reversible, Flexible and Handsomely Finished.
Made of Heavy Gold-Filled Stock
And Guaranteed to Give Entire Satisfaction.



No. 16401

Can You Consistently
Pass this Article in Justice
to Your Business?

If you are not willingly supplied,
write us to refer you to the
Jobber who handles them.

Become acquainted to-day.
Sold exclusively to the Jobbing Trade.

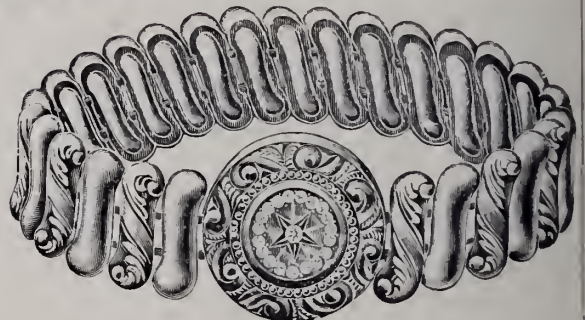

No. 16423

N. Y. Office
9 Maiden Lane

Attleboro Chain Co.

Factory at ATTLEBORO, MASS.

THE OPTICAL REVIEW

A High Class Magazine for Opticians and Optometrists.

CONTENTS FOR MAY.

Theory and Practice in Cases of Squint, by W. W. Kerr, Fullerton, Cal.
Studying the Case from All Sides, by Ethelred Curtis, Laporte, Indiana.
Methods of Precision in Optometry, by John C. Eberhardt, Dayton, Ohio.
Medicine's Only Serious Objection to Optometry, by Thomas G. Atkinson, M.D., Chicago.
Method of Ordering Toric Lenses, by W. W. Slade, Boston.
Getting a Satisfactory Light in Skiascopy, by E. Le Roy Ryer, New York.

Facial Measurements and Frame-Fitting, by John F. House, Fulton, Ky.
Methods and Means of Examining, by G. C. Savage, M.D., Nashville, Tenn.
Digest of Current Optical Literature—Optometrist's Catechism—Examination Room Work—Questions and Answers—Frame Fitting—Making the Sale—Editorials—News of the Month—Convention of the Kentucky State Optical Association—Meetings of Societies—Optometry Legislation—Patents.

We exclusively extend to subscribers of THE JEWELERS' CIRCULAR-WEEKLY the privilege of subscribing to THE OPTICAL REVIEW at one-half price—50 cents per year. If you have not already mailed your subscription, simply sign and return the attached form, sending no money in advance. Carefully read the blank below. Send at once and get the May issue.

ISSUED MONTHLY.

SUBSCRIPTION, \$1.00 PER YEAR.



Published by
THE JEWELERS' CIRCULAR PUBLISHING CO.,
11 John Street, cor. Broadway, New York

Commence

N. B.—This subscription will be billed concurrently with your Jewelers' Circular subscription. It can be stopped at any time.

Please enclose your business card or printed address

..... 190
Send "THE OPTICAL REVIEW" to my address until otherwise ordered, for which I agree to pay **50 cents a year** as a special introductory combination price with my subscription to the JEWELERS' CIRCULAR-WEEKLY.
Name
Street
City.....
State

Pittsburg.

Otto Heeren, of Heeren Bros. & Co., who has been in the habit of going abroad every Spring, may defer his visit this year.

George W. White, of West, White & Christy, went to New York last week on a visit. His wife is visiting relatives in Brooklyn.

Henry Wilkins & Co. have very comfortable quarters in their new location in the Pittsburg Life building, having recently moved there from Wood St.

The store of Jacob Klein, in Braddock Ave., Braddock, was entered one night recently and a quantity of jewelry, revolvers and other articles were stolen. It is believed that boys committed the robbery.

The store of Benjamin Klein, in Fifth Ave., McKeesport, was damaged by fire last week to the extent of \$400. The blaze started among some papers on Mr. Klein's desk, in his private office. The loss is said to be covered by insurance.

A handsome drawing showing the front elevation of the proposed new market house to take the place of the present structures was displayed last week in the windows of the Hardy & Hayes Co. It is proposed to build the new city hall on the Market house site.

Out-of-town jewelers noticed in Pittsburg in the past week buying stock were: B. E. Brown, Monessen; H. R. Brown, Donora; F. H. Hayes, Washington; Thos. H. McKinley, Greensburg; John Zugschwert, Carnegie; F. W. Berkeley, Homestead; Allen Linnenbrink, Rochester.

The pawnbrokers of the North Side are furnishing daily reports of all articles pawned, these reports being placed in the hands of the police department every morning. The reports are of incalculable value and have frequently enabled jewelers to recover property secured by persons who had defrauded them.

Max Hall, who would not tell the police where his home is, was arrested last week in Federal St., North Side, by detectives, while attempting to sell imitation jewelry. He was captured while trying to sell a ring which had all the appearances of being a genuine ruby, surrounded by a score of supposed diamonds. All the jewelry in his possession was of the cheapest character.

Charles Slemmers last week made a special exhibit of watches for the Illinois Watch Co. at the store of John M. Roberts & Son Co., and it attracted considerable attention. The Roberts house caused to be erected a huge oilcloth sign in the front of its former location in Market St., setting forth the fact that the company now occupies new quarters. It is one of the largest signs of the character ever erected in Pittsburg, covering almost the entire front of the building. It serves as a splendid advertisement.

The members of the Jewelers' Duckpin League have arranged for a banquet to be held May 21 in one of the Pittsburg hotels. The league members also attended the Duquesne Theater on Monday night. A handsome bronze cup has been presented to the league, donated by a large wholesale jobbing house, and it is to be competed for, for a period of three years, to

become the property of the successful team at the end of that time. The league rolled the usual games Thursday night. Wattles Team No. 1 won four games from Roberts Team No. 2; the Reed Team took four from the Vilsacks; Roberts No. 1 won three out of four from Wattles No. 2. The Wattles No. 1 team now leads in the standing of the clubs by one game. The cup, which has been presented to the league, is being displayed in the window of E. P. Roberts & Son Co.

Connecticut.

Frank R. Wallace arrived home at Wallingford, April 13, from a European trip.

W. A. Ingraham, Bristol, has been elected assistant vice-president of New Britain's new Fish and Game Protective Association.

Robert Robertson, aged 50 years, of Glastonbury, died April 18, after taking ammonia by mistake. Mr. Robertson was employed by the Williams Bros. Mfg. Co.

President Walter Camp, of the New Haven Clock Co., New Haven is the writer of an interesting article on "Early College Baseball" in the April issue of the new *Baseball Magazine*.

Elaborate ceremonies marked the presentation, Wednesday, to the National Chapter, Daughters of the American Revolution, of a hall clock by the Berks County Chapter of Pennsylvania.

The engagement is announced of John Wallace Leavenworth, of Wallingford, and Miss Mabel E. Fowler. The wedding will take place May 12, at St. Paul's Episcopal Church, in Wallingford.

Two attempts were made about a week ago to break into the pawn brokerage store of Ralph Jacobs, 61 S. Main St., Waterbury. The attempts of the intruders were prevented by the ringing of the burglar alarm, with which the store is equipped.

The Meriden Britannia Co. (International Silver Co., successor), Meriden, has been awarded the contract to supply all the silverware that will be used by the various railroads and steamship lines, as well as hotels and restaurants comprising the so-called Harriman lines.

Burglars recently broke into the jewelry store of Henry S. Townsend, Winsted, and stole two strings of gold beads, 30 gold and gold-filled watches, two solid gold vest chains, 15 charms and locket, several solid gold emblems and 10 gold-filled watch chains, the entire stock being valued at about \$600. The thieves are believed to be experienced in their work owing to the manner in which they selected the valuable pieces of jewelry.

The world's largest clock, made recently by the Seth Thomas Clock Co., Thomaston, for the factory of Colgate & Co., in Jersey City, and described in the issue of THE CIRCULAR-WEEKLY, of April 1, was shipped Saturday to Jersey City. Two cars were required for the mammoth timepiece, a flat car for the hands and a box car for the works. Representatives of the clock company went to Jersey City to direct the work of setting up the timepiece.

W. B. Harris will continue the business of the old firm of Harris & Dunsworth, Mounds, Ill., which recently dissolved.

Boston.

Lieut.-Col. Murray D. Clements, of Waltham, who has been identified with the State militia about as long as he has been with the Waltham Watch Co.'s factory, has just retired with the rank of colonel.

Henry W. Patterson, of Smith, Patterson Co., has returned from an outing trip to Bermuda. Joseph C. Batchelder, head of Smith, Patterson Co.'s silverware department, was in New York and Philadelphia on a business trip during the week.

A show window in the store of C. Alberts & Co., 749 Washington St., was smashed last Wednesday night by would-be robbers, who were frightened away before securing any of the goods in the window display, by a neighboring storekeeper who had witnessed the affair. The perpetrators escaped.

The Thomas Long Co. has reorganized under Maine corporation laws, increasing its capital stock to \$75,000, and taking over the business of the Massachusetts corporation of the same name. The officers are: President, Charles W. Davidson; secretary and treasurer, Frank F. Davidson; directors, these officers with C. E. Freeman and George Moses.

Edward H. Owen, aged 83 years, died at his home in Waltham April 19. He was for nearly 40 years at the head of the case department of the Waltham Watch Co.'s factory during the period when cases were manufactured at the plant prior to the organization of the Crescent Watch Case Co. He was one of three brothers, Edward, Easton and Sheldon, all of whom were identified with the factory in its earlier years, and Easton Owen still survives. Edward was at one time associated with Daniel O'Hara, who now has the dial factory in Waltham. He leaves a widow.

President M. N. Smith, of the Boston Jewelers' Club, this week has submitted to the Boston newspapers copies of the New York *Herald* interview of April 23 with Louis Abrahams, president of the diamond syndicate which controls 98 per cent. of the diamond output. Mr. Smith also requested that publicity be given to this interview in which all the silly rumors about the diamond market are denied by Mr. Abrahams, equal to the publicity that was given recently to the price-reduction dispatches printed in the daily papers. Mr. Smith suggests that similar action should be taken by leading jewelers and their associations in all sections of the country.

The quarterly dinner of the Boston Jewelers' Club, April 21, was held in the banquet hall of the Exchange Club instead of at a hotel as had been customary heretofore. There were about 60 participants, President M. N. Smith presiding, and addresses were made by Mr. Smith, Henry C. Long, F. L. Howard and Rev. Charles L. Merriam. Edward S. Simons, of Philadelphia, who was one of the guests of the occasion, contributed to the evening's enjoyment with his singing. A souvenir pipe was presented to each of those attending by Frank S. Sherry, chairman of the souvenir committee. The club voted to raise its membership limit from 75 to 100, on account of the large waiting list.



GNTERPRISING and successful jewelers everywhere are pushing the sale of some individual line of watches which they believe to be superior to all others, and upon which they can also make a satisfactory and justifiable profit.

This explains the growing demand for ILLINOIS WATCHES, in 0, 12, 16 and 18 sizes, by increasing numbers of leading jewelers throughout the United States.

If you are not familiar with the superior quality of—and advantages gained by handling—Illinois Watches, it will mean reputation and dollars for you to investigate.

Every one fully guaranteed.
Price List sent on application.

ILLINOIS WATCH COMPANY
SPRINGFIELD



Chicago Notes

Lee Wechter is on a trip northwest.
 C. J. Roehr is back from a southwestern trip.
 Fred H. Allen is the father of a baby girl, born April 25.
 George Weidig made a flying trip to Cincinnati last week.
 Leon Gross is back from a 10 weeks' trip from the Pacific Coast.
 E. M. Lunt, with the Towle Mfg. Co., visited Toledo, O., last week.
 J. E. Reagan, of the Baldwin, Miller Co. Indianapolis, was here last week.
 John Braude, with the Keller Jewelry Mfg. Co., is on a trip to New York.
 The Bauman Jewelry Co. will remove, May 1, from 72 to 110-112 E. Madison St.
 J. J. Decker is the new representative of the Rochelle Clock & Watch Co. in Chicago.
 Dr. B. L. Dunn, of the Oneida Community, Ltd., was here two days last week.
 Herbert E. Cobb has returned from a visit to the factory of the Daggett & Clap Co.
 Norbert Gunsburger, with L. & M. Kahn & Co., has returned from a trip to New York.
 Joe Eisner, formerly with Despres, Bridges & Noel, is now with F. W. H. Schmidt.
 Emanuel Untermeyer, of the Untermeyer-Robbins Co., and Chas. Keller & Co., was here last week.
 Fred A. Thompson, watch repairer and jeweler, will remove, May 1, from 1940 to 2965 Evanston Ave.
 J. T. Brayton and Mrs. Brayton spent a few days last week at their Summer home at Lake Kinkinosh, Wis.
 Chas. W. Krauss, father of E. O. Krauss, with the Western Watch Case Co., died here recently, aged 72 years.
 Leon Nordman, San Francisco, accompanied by his wife, was here last week on a six weeks' trip to the east.
 Frank McKey, the former receiver of the Madson-Steele Co., has been appointed trustee of the estate under a bond of \$10,000.
 A. L. Sercomb, Chicago manager for the International Silver Co., recently returned from a six weeks' trip to the Pacific Coast.
 All indications point to a successful composition at 40 cents on the dollar of the liabilities of the Shourds, Adcock, Teufel Co.
 The Chicago office of Henry G. Le Fort has removed from the Chicago Savings

Bank building to room 902 Heyworth building.

A delegation of 100 business men from Tulsa, Okla., were entertained here last week by the Chicago Association of Commerce.

The Illinois Watch Case Co. and the Rockford Watch Co. have removed from the Silversmiths' building to the Heyworth building.

Morris Feinberg, Ironwood, Mich., will soon remove to 11208 Michigan Ave., the store formerly occupied by Conrad Heegn, Jr.

H. Schwartz, diamond dealer and buyer of stocks in the Chicago Savings Bank building, has removed to room 903 Heyworth building.

W. S. Metcalf, of the Plainville Stock Co., was here last week on his way east. Mr. Metcalf made a trip to Tahiti with Walter Marble.

The Chicago office of the E. A. Potter Co. after May 1 will be located at 902 Heyward building, with Harry A. Farquharson in charge.

Alfred Elsner, formerly with L. H. Schaefer & Co., has engaged in the tailoring business. The mother of Mr. Elsner died here recently.

"Moe" Loeb, with the Dueber-Hampden companies, was here last week. Dan W. Douglass, with the same companies, has returned from a western trip.

S. R. King, with the C. H. Knights-Thearle Co., has returned from a trip through Iowa and Nebraska, and will undergo a slight operation here.

Calvin Clauer, South Bend, Ind., after a visit to West Baden, was here last week buying some merchandise from Keil & Hettich, who have retired from business.

There is going to be a "warm" game of ball on Saturday, May 2. Salesmen representing various watch case companies are to play against a select nine of jobbers' salesmen.

Mr. and Mrs. A. C. Becken celebrated their 25th wedding anniversary, April 20. The guests included Mrs. Becken's parents and friends from various parts of the United States.

Whiting & Davis, Plainville, Mass., will open an office here in July in charge of Frank Whiting, who will reside here after that date. The new office will probably be in the Columbus Memorial building.

Abelson & Co., a new instalment jewelry firm in room 506, Chicago Savings Bank

building, is composed of Louis Abelson and Morris Feltenstein. The latter is a son of Aaron Feltenstein, of the Star Diamond Co.

W. J. Dunn, with Arnold & Steere, and W. A. Fay, with the John T. Mauran Mfg. Co., are making a trip together to St. Louis, Cincinnati, Pittsburg, Cleveland and Detroit, and will then visit the northwest. Mr. Fay leaves for the Pacific Coast about May 25.

Ernest Dayton, son of E. A. Dayton, recently became the father of a baby boy. Mr. Dayton has charge of the city material department of E. W. Reynolds & Co., Los Angeles, Cal. Both the father and grandfather are elated over the advent of the new arrival.

Jos. Brown & Co. are offering to settle with their creditors at 25 cents on the dollar, 12½ cents cash and 12½ cents on six months' notes. The six months' notes are to be indorsed by Jos. Brown and S. M. Jess. The stock has been appraised at \$55,550, of which \$1,300 is in diamonds and diamond jewelry and \$5,000 in optical goods.

The receiver's inventory of the estate of the F. C. Happel Co. shows the assets to be as follows: Stock, \$30,019; memorandum returns, \$636.85; in salesmen's trunks, \$14,414.49, \$10,811.50 and \$10,857.41; fixtures, \$1,190.45; accounts receivable (90 per cent. good), \$32,800.17; bills receivable, \$325.28; real estate, \$1,000, or a total of \$102,057.25.

Harry Meyers, arrested last week charged with the theft of a diamond ring from Nordahl & Olsen and Turner Bros., is also charged with the theft of a \$200 diamond ring by the Lewy Bros. Co., State and Adams St. Meyers called at the latter store, and after looking at some diamond rings left without making a purchase. After he had gone the ring was found to be missing.

Out-of-town jewelers here last week were Charles J. Linden and Henry E. Volkman, Kankakee, Ill.; Julius Liebenow, Green Bay, Wis.; Sam B. Hall, Sullivan, Ill.; John Sievers, Hebron, Ind.; O. L. Rosenkranz, Milwaukee, Wis.; R. A. Woodward, Sandwich, Ill.; August Bruder, Ft. Wayne, Ind.; C. W. Connoran, Indianola, Ia.; John W. Neasham, Ottumwa, Ia.; Wm. T. Jennings, Sterling, Ill.; S. O. Harvel, Litchfield, Ill.

An involuntary petition in bankruptcy has been filed against the Maison Nouvelle, a ladies' furnishing goods store at 44 E. Madison St. The petitioning creditors and amounts due them are A. & E. Leather Goods Co., \$1,200; Kolb & Teich, \$260, and

We Can Furnish You a Catalog of Your Own

Containing from 36 to 200 pages or over

ILLUSTRATING SUCH GOODS AS YOU HANDLE

And arranged to meet your local conditions

That Will Increase Your Business from 25 to 100 Per Cent.

READ OUR CUSTOMERS LETTERS

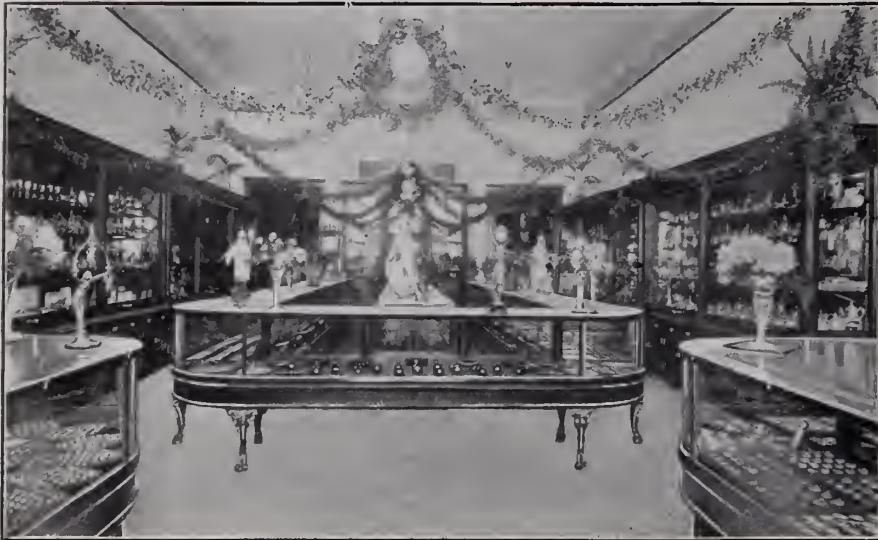

STORE OF THE ERNSTING COMPANY, Inc., SAN DIEGO, CAL.

(Extracts from letter.)

SAN DIEGO, Cal., Jan. 23, 1908.

The Arnstine Bros. Company,
Cleveland, Ohio.

GENTLEMEN:—Regarding the results of our 1907 Catalogues we beg to state that we are so pleased with work the Catalogues have done for us, that we want to figure with you for next season. Now that we have had some experience in this line we feel that in issuing the next edition we can offer some suggestions that will be of great advantage to us.

Thanking you for your many kind courtesies and wishing you every success, we beg to remain, yours truly,

THE ERNSTING CO.,

C. W. Ernsting, Prest.

**Full particulars and
samples on request**

(Extracts from letter.)

READING, Pa., Jan. 24, 1908.

The Arnstine Bros. Company,
Cleveland, Ohio.

GENTLEMEN:—Answering your letter regarding your Catalogue, I would say that I was very well pleased with them and do not see how the appearance of the book could have been improved.

Your dealings with me have been perfectly satisfactory and have given no cause for complaint.

Thanking you for past favors, I remain,

Yours very truly,

G. A. SCHLECHTER.

**What we have done for others—
we can do for you**

**Write at once for samples
and particulars FREE**

Our representatives visit nearly every State in the Union. If you are interested, and will notify us, our representative will take pleasure in calling on you and explaining our method.



STORE OF G. A. SCHLECHTER, READING, PA.

THE ARNSTINE BROS. COMPANY

Originators of Our Exclusive Catalog Method for the Retail Jeweler

CLEVELAND, OHIO

IN WRITING US PLEASE MENTION THIS ISSUE "JEWELERS' CIRCULAR-WEEKLY"

M. A. Eisenman & Bro., \$65. The petitioners allege that the concern paid J. C. Hacker, Brown & Mills and other creditors sums of money with a view to preferring them. The American Trust & Savings Bank was appointed receiver, and is now closing out the business at retail. The concern owes considerable money for novelties jewelry.

Schedules in bankruptcy of Conrad Heegn, Jr., 11208 Michigan Ave., show the creditors for more than \$100 to be as follows: From \$100 to \$200—Despres, Bridges & Noel, Dattelbaum & Friedman, A. L. Williams & Co., F. L. Shepardson & Co., Buchsbaum & Co., C. T. Wittstein & Co. The largest creditors are: H. C. Kionka & Co., \$218; S. F. Scott Co., \$695; Rettig, Hess & Madsen, \$359; Heintz Bros., \$308; Otto Young & Co., \$188. The receiver's inventory show liabilities of \$3,742. Stock, fixtures, tools, etc., were estimated at \$3,160, but the appraisal of the estate was a little less than \$800. Heegn claims \$100 cash exemption under the bankruptcy act. Otto Young & Co., S. F. Scott & Co. and Despres, Bridges & Noel hold altogether \$582.95 worth of merchandise as security for part of their claims. The receiver will bring suit for the recovery of this merchandise or its equivalent. The next meeting of the creditors is set for 11 o'clock on May 1, before Referee Wean.

Cincinnati.

William Pflueger, of Jos. Noterman & Co., is calling on his western trade.

George B. Hovekamp, of the Miller Jewelry Co., has left on a business trip among the southern trade.

Sig Strauss, of Lindenberg, Strauss & Co., has returned from a long sojourn in New York and Atlantic City.

Mr. Phillips, watchmaker for the Oskamp Jewelry Co., is away from business and is threatened with typhoid fever.

A. A. Spiegel and M. Plaut, of A. A. Spiegel & Co., left on their respective trips through Indiana, Ohio and eastern territory.

Leonard James Fox, of the Gustave Fox Co., has started on an extended business trip which will cover Chicago, Philadelphia and New York.

J. H. Sherwood, Brooksville, Ky., stated to friends here last week that he is contemplating on moving to Benton, Ark., in the near future.

J. Fred Kramer, of the Frank Herschede Co., is erecting a handsome two-story brick dwelling on Hemlock St., Walnut Hills, which he will occupy.

S. C. Bingamin has taken possession of his new quarters, 509 Vine St., which he calls the "Crown," and had his opening April 25. Mr. Bingamin has been congratulated upon the handsome appearance of his store, which is arranged in an artistic manner.

Anthony Herschede's store, 917 Main St., was on Thursday the scene of a very serious accident to Richard R. Stone, aged 86 years, and the oldest attorney in this city. In some unknown way Mr. Stone fell to the bottom of the stairway leading to the cellar of Mr. Herschede's store. When taken up he was unconscious, and exami-

nation disclosed that his skull was fractured. Owing to his age there is little hope for his recovery.

Out-of-town jewelers here the past week purchasing stock included: Frank Fullilove, Owenton, Ky.; Ed. Mueller, Hamilton, O.; Mr. Duncanson, Lynchburg, O.; Mr. Dougherty, Bethel, O.; S. Gardner, Hinton, Ky.; A. B. Wilson, Pinesville, Ky.; W. N. Rigdon, Ohio City, O.; J. G. Laupus, Seymour, Ind., and A. L. Wade, Bradford, O.

A meeting of the local Retail Jewelers' Association was held April 24 in the Palace Hotel, when arrangements for the coming convention were discussed and reports of the various committees were read. The association members feel they are to be congratulated upon their successful efforts in the disposing of space for the exhibits, and that things are moving along very nicely.

B. S. Newman, of Frohman & Co., before his departure, with Mrs. Newman, for Europe gave a number of his friends "a good old-fashioned German lunch," April 24, in the company's spacious quarters, a part of which was fitted up with tables laden with an abundance of good things for the occasion. S. M. Peck, of Peck, Selmeier & Peck, was master of ceremonies. S. Lindenberg, of Lindenberg, Strauss & Co.; A. J. Thoma, of Thoma Bros., and Julius Grunauer added much merriment to the occasion by telling some very entertaining stories. Miss Laura Metz and Miss Hilda Slickman, of the company, were present and served the lunch. Among those present were S. Lindenberg, H. Bohmer, Sr., M. Schwab, Robert Vaupel, A. Herman, J. Frohman, Jonas Wise, B. S. Newman, John Gerwe, S. Peck, Joseph Posner, Anthony Thoma, Julius Grunauer, Burton Fox, Abe Wise, George Wise, Arthur Luthy, H. Kahn, Louise Schroeder and George Hug.

Cleveland.

Mrs. John Rich, Painesville, O., was in this city last week.

Leo M. Hoffman, of the Webb C. Ball Watch Co., is in the east.

Ben Ginsburg intends to start up again in the manufacturing business.

Capt. R. E. Burdick returned, Monday, from a week's visit in New York.

Ed. Smith, son of Walter G. Smith, Youngstown, O., visited here recently.

A. M. Strobe has taken a position as watchmaker with Burt Ramsey & Co.

H. S. Hurlbut, of the Scribner & Loehr Co., has just started on the road again.

W. E. Loeb, of the Dueber-Hampden companies, was in Cleveland last Saturday.

Sidney Y. Ball, of the Webb C. Ball Watch Co., has just returned from a trip through southern Ohio.

A. E. Kintner intends to sell his jewelry store at Painesville, O., and go into other business, with headquarters at Cleveland.

C. J. McCormick has been called to Millersburg, O., to take charge of the jewelry store of his father, N. P. McCormick, who is very seriously ill.

Some convivial spirit recently set fire to the Force Bros. Co. awning by tossing a lighted cigar thereon. A policeman extin-

guished the incipient conflagration before any damage was done.

The following dealers have been in the city recently: A. E. Kintner, Painesville, O.; F. N. Prevey, Akron, O.; Clem Hewitt, Greenville, Pa.; H. C. Jason, Lodi, O.; Wm. Kurtz, Bellevue, O.; H. H. Brainard, Medina, O.; F. R. Montgomery, Sandusky, O.; W. C. Fisher, Lorain, O.; O. G. Carter, New London, O.; A. H. Coleman, Massillon, O.; A. E. Oyster, Alliance, O.; A. J. Heiman, Barberton, O.; Robert Miller, Lorain, O., and T. H. Park, Mantua, O.

Pacific Coast Notes.

H. E. Rader, Monrovia, Cal., has added an optical department.

E. M. Clark, Riverside, Cal., has moved his stock of goods into a new location on Howard St.

Mr. Huey, a diamond merchant of Excelsior Springs, Mo., is visiting in Los Angeles, Cal.

The Selka Jewelry Store, Marysville, Cal., is holding a creditors' sale and everything will be sold.

F. J. Gehres has arrived in Colusa, Cal., from San Francisco, and will immediately open his new store in the building next to O'Rourke's store.

Don Ross, who has been in the employ of Carl Mueller, Eureka, Cal., for the past two years, has left for Colorado, where he will go into business for himself.

Articles of incorporation have been filed by the American Jewelry Co., at Bakersfield, Cal. The incorporators are Nat R. Solomon, Charles G. Law and B. Snyder, all of Bakersfield. The capital stock is \$100,000.

The Carrizozo Pioneer Jewelry House which was established in the fall of 1907, by F. M. Rhomberg, at El Paso, Tex., under the management of J. R. Humphrey, has recently changed hands, Mr. Humphrey assuming the proprietorship. Mr. Rhomberg, an expert optician, has taken charge of the optical department.

Denver

Mr. Bride, of Bride & Tinckler, called on the local trade last week.

Chas. Hannan, Sussteld, Lorsch & Co., was in this city for a few days last week.

Frank Kline, of Burnett & Co., was recently presented with a loving cup by the jewelers of this city.

R. L. Moore, formerly of Chas. J. Doersam, has taken a position at the head of the watchmaking and engraving department of Evan Friedheim.

A. E. Hawkins, of the Edward Lehman Jewelry Co., returned last week from an extended trip through the northwest. A. N. Jacoby, of the same firm, made a business trip around the Horn, and reports a satisfactory trade. He says that the jewelers will do a good business this Summer.

Wm. Klein, once a resident of Harrisburg, Pa., where he conducted a jewelry store on Market St., died recently at the Harrisburg Hospital, of Bright's disease, aged 58 years. The body was sent to Philadelphia for interment.

Hull Detachable and Interchangeable Handle Umbrellas

were first put on the market in 1900, after a year spent in perfecting them. They are made to-day exactly as we made them then, so any one having a handle bought of us eight years ago can attach it to any detachable umbrella we make to-day. Our imitators have put many makeshift detachable handles on the market since then. Some makers brought out four kinds in as many years, all of which were unsatisfactory.

We believe a merchant must become disgusted when asked to buy a different detachable feature each year, none of which will interchange. The day is past for a jeweler to buy umbrellas without interchangeable handles. Then, why not do what thousands of the most successful merchants have done for years, viz.: buy umbrellas with a reputation and with a detachable feature which is "the same yesterday, to-day and forever"? Buy umbrellas with the name HULL on the button. "It means as much as Sterling."

Our line of Handles for the coming Holiday Season is now ready for your inspection.

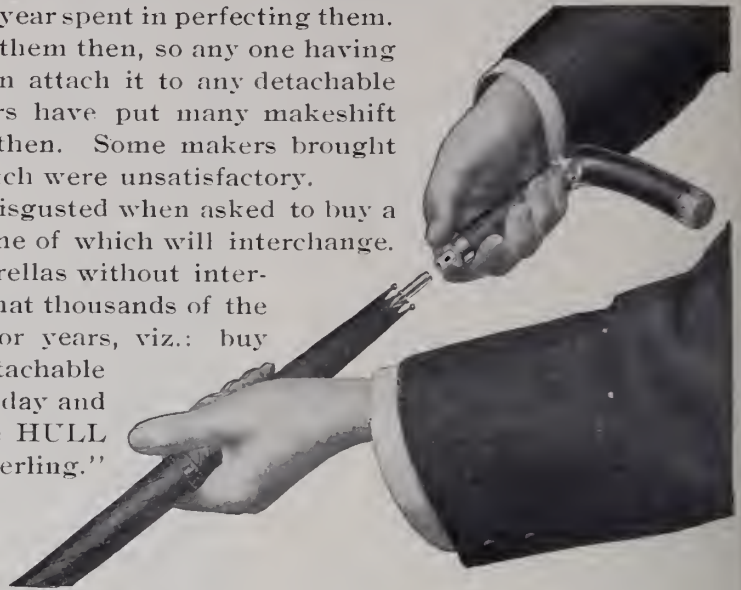

Hull Brothers Umbrella Company

344 - 346 Summit Street,

Toledo, Ohio

H. J. HOOPER

NEW YORK'S LEADING JEWELRY AUCTIONEER—RECOGNIZED BY THE WHOLESALE HOUSES, THE PRESS AND HIS PATRONS

Write him for Testimonials that cannot be equaled by any Auctioneer in New York

37 MAIDEN LANE,

NEW YORK CITY

The names that I publish below are merchants I have sold for direct; there are no wholesalers among them. Anyone wanting the wholesalers I have sold for indirectly, I will furnish by mail.

Ike Fields, Grass Valley, Cal.
George Johnson, San Bernardino, Cal.
R. F. Stearns, Stockton, Cal.
Thomas Howard, Marshfield, Oregon.
Franz Mahneke, Tacoma, Wash.
I. H. Shade, Brooklyn, N. Y.
John E. Knapp & Co., Salt Lake City, Utah.
James J. Tracey, Seattle, Wash.
Charles Hoff, Denver, Colo.
E. A. Walker, Pasadena, Cal.
R. Cohen, Pittsburg, Pa.
F. R. Williams, Buffalo, N. Y.
R. W. Wilson, Portland, Oregon.
Fred Woodman, Louisville, Ky.
M. Rundback & Co., Chicago, Ill.
Glendemann & Schweitzer, San Francisco, Cal.
Luke MacDonald, Visalia, Cal.
Bemas Brothers, Vallejo, Cal.
A. Tucker, Newport News, Va.
J. Luxenberg, Patton, Pa.
A. Lison, Kingston, Pa.
M. C. Khuner, Auburn, N. Y.
Everett Jewelry Co., 3 sales, Everett, Wash.
W. D. Meail, Marysville, Cal.
J. Joseph, Los Angeles, Cal.
A. Leibson, Duryea, Pa.
Davidow Brothers, 3 sales, Wilkesbarre, Pa.
Maiden Lane Jewelry Co., Elizabeth, N. J.
Dualbil Brothers, Schenectady, N. Y.
Fred Ward, Visalia, Cal.
I. E. Gilbert & Sons, Modesto, Cal.
M. L. Stanton, Riverside, Cal.
A. E. Backs, Woodland, Cal.
M. S. Osgood, San Jose, Cal.
Chas. Wilcoxon, Napa, Cal.
George Jordan, Redawn, Cal.

George Thomas, Auburn, Cal.
W. H. Wilson, Merced, Cal.
South Bend Jewelry Co., South Bend, Wash.
B. Banetti, Ferndale, Cal.
D. E. Gilbert, Modesto, Cal.
M. Barboska, Santa Cruz, Cal.
L. Robins, Utica, N. Y.
Yoshimi & Co., Atlantic City, N. J.
Cummings & Son, San Francisco, Cal.
J. M. Ives, Meriden, Conn.
E. H. Kutner, Albany, N. Y.
S. Susman, Stamford, Conn.
Rival Jewelry Company, Los Angeles, Cal.
A. H. Broom, Boise City, Idaho.
Levison Brothers, Oakland, Cal.
O. A. Dockhan, N. Tonawanda, N. Y.
A. Benjamin, Denver, Colo.
M. BasBarker, Fresno, Cal.
J. M. Dickson, Stockton, Cal.
J. M. Jacobsen, Ferndale, Cal.
J. Rupert, Terentum, Pa.
C. O. Biederman, Oneonta, N. Y.
Freeman Jewelry Co., Niagara Falls, N. Y.
Arritt & Co., Newport News, Va.
T. J. Routledge, Elmira, N. Y.
Rosenblatt & Co., Greenville, Tenn.
M. Marter, Cottage City, Mass.
J. F. Rockwell, Port Jervis, N. Y.
J. M. Frear, Binghamton, N. Y.
Palace Jewelry Co., Auburn, N. Y.
J. Luxenberg, Ilurtzdale, Pa.
H. Hedges, Fairmount, W. Va.
A. E. Morro, Los Angeles, Cal.
A. B. McKevey, Pasadena, Cal.
Bogart & Page, Binghamton, N. Y.
A. F. Redfoot, Mt. Jewett, Pa.



L. Robins, Oswego, N. Y.
Blumberg Brothers, Syracuse, N. Y.
Sun Fat Company, San Francisco, Cal.
Peter Engel, Marysville, Cal.
S. Hollander, Salinas, Cal.
A. P. Hall, Visalia, Cal.
M. Edwards, Syracuse, N. Y.
C. Wilcoxon, Carnegie, Pa.
Keystone Jewelry Co., Pittsburg, Pa.
E. A. Walker, Pasadena, Cal.
S. E. Rich, San Jose, Cal.
Andrews & Wood, Modesto, Cal.
A. Thurman, Healdsburg, Pa.
J. Frost & Co., Chicago, Ill.
A. Clark, Spencer, Ind.
C. Hill, Southbridge, Mass.
U. S. Renshaw, Lansford, Pa.
L. M. Lasell, Martinez, Cal.
E. F. Brown, Pasadena, Cal.
J. Hyman, Sacramento, Cal.
Kohn Brothers, Missoula, Montana.
F. R. Stearns, 2 sales, Petaluma, Cal.

Los Angeles.

The Ellis Jewelry Co. is now fully established and doing business at 230 S. Spring St.

Paul D. Walsh, of Hambright & Walsh, has returned from a business trip through the north.

Guy Hale, of N. B. Hale & Son, San Bernardino, was here, accompanied by his wife, last week.

Jacob Levinson, corner of 1st and Spring Sts., has returned from a trip to San Diego and other towns of southern California.

Albert G. Stein, representing Patek, Philippe & Co., visited S. Nordlinger & Sons, agents of the company here, last week.

Most of the leading jewelers, wholesale and retail, closed their stores during the afternoon of the day the Atlantic fleet arrived in San Pedro.

A. E. Baranger, representing the E. W. Reynolds Co., is making a business trip through the towns of southern California. He will be gone from four to six weeks.

J. P. Tait, head salesman for Edward Gerson, who was married April 15 to Miss L. Allen, of this city, has returned from his wedding trip and is again at work in the store.

Among the jewelers from out-of-town who have been here recently were: E. M. Clark, Hemet; R. W. Cummings, Ventura; O. G. Tullis, Santa Monica, and C. W. Ernsting, San Diego.

George H. Marcher, secretary of the Pacific Gem Co., started for the east, via Salt Lake, Denver and Chicago a few days ago on a business trip. He expects to be absent about four months.

Ernest Pollack, Riverside, and his wife, were here last week to see the fleet and take in the accompanying festivities. They came by automobile and were the guests while here of Mr. Hambright, of Hambright & Walsh.

Newton Moore, 354 S. Broadway, is an enthusiastic Shriner. He participated as such in the recent Shriners' Circus, held in this city, attempting to ride a camel. The camel was ugly, and threw Mr. Moore violently to the ground, injuring him quite severely.

Announcement is made of the engagement of Miss Ethel Levinson and Herman Ellenstein, the latter of New York. Miss Levinson is the daughter of Jacob Levinson, wholesale jeweler in the Wilson block, whose office manager she has been for a number of years.

Montgomery Bros., last week, while the fleet was here, made what was probably one of the finest displays of stationery ever seen on this coast, comprising samples of 15 orders of exceptionally fine work taken for social functions to which high officers of the fleet were invited.

Witcher J. Taylor, a watchmaker and jeweler, who has recently located at 841½ S. Spring St., reported to the police that nine watches, valued at \$100, were stolen from his safe some time between Saturday night and Monday morning. The safe is a small one which locks with a key, and the burglar evidently possessed a key which fitted the lock, as the safe was found locked Monday morning after the watches had been taken. In moving Mr. Taylor lost

the numbers of the watches, and the police are therefore handicapped in their efforts to locate the stolen goods. The watches were Mr. Taylor's personal property. He reports that he was robbed of a valuable gold watch only a few months ago.

Detroit.

C. E. Montfort came in from Utica last week.

George Johnston is back from a trip to Atlantic City.

R. W. Wagner, Toledo, O., called on the wholesale trade recently.

F. P. Mathauer, of Mathauer & Koester, left, Friday, for a trip to the upper peninsula.

Three local jewelers were ill last week—John Kay, Hugh Connelly and Albert Schaub.

Walter H. Beck, 548 Baker St., is having alterations made to his store. A new front is being erected.

J. P. Phillips, Bowling Green, O., was in this city recently. He has just concluded a successful auction sale.

F. B. Roehm was away last week through the college towns of the State, and found the demand lively for college jewelry.

E. C. Avery, traveling representative for the Chas. A. Berkey Co., returned, last week, from a five weeks' trip through Ohio.

Noack & Gornnlo purchased the stock of the mysteriously missing Samuel Stern last week at a sale ordered by the Bankruptcy Court.

The hearing for James Sullivan and John Conors, accused of robbing John Hellerich's store, at 510 Gratiot Ave., has been postponed until May 1.

Among the out-of-town dealers who were in Detroit last week were: George H. Johnson and Ed. Merritt, Northville; F. H. Nissley, Saline; W. W. Bridges, Marine City; A. L. Miller, Belleville; H. W. Baxter, Birmingham; Theo. Dahlmann, Rochester; Mr. Henning, of Henning & Koch, Ann Arbor.

Many of the wholesalers and jobbers who have written the Detroit Jewelers Board of Trade in regard to the projected national association urge this board to go ahead with plans for the organization. The replies so far have been uniform expressions of confidence in the success of the plan. A special meeting of the Detroit board will be called soon and a definite date set for a meeting here to form the organization.

A special endeavor has been made by the city's board of assessors to increase the personal tax assessments for 1908. In this movement the jewelers have been reached rather more uniformly than other branches of trade, and most of the firms have been given a higher valuation than last year. Some will protest to the Board of Tax Review. W. A. Sturgeon & Co. having already given notice that they will protest an assessment of \$100,000, as their stock is being sold out at auction. A new entry on the tax rolls is that of John Kay & Co., which is put down at \$52,800.

Geo. O. Sawyer, a jeweler and stationer of Ainsworth, Nebr., is planning the erection of a new store building.

Indianapolis.

C. M. Hunnicutt, Rockville, was in this city last week, buying stock.

M. Meyer, Marion, is occupying a new store room, which has been handsomely fitted up with new fixtures.

I. Grohs, head of the I. Grohs Jewelry Co., spent part of last week in Crawfordsville and Logansport on business.

After an illness of seven weeks, following an extensive western trip, Frank L. Bryant is again able to be at his place of business.

In the future H. A. Winn will conduct only one store—that in the Pembroke Arcade, having closed his E. 25th St. store in the suburb of Brightwood.

Burglars robbed the store of John C. Ertel, 209 Massachusetts Ave., last Thursday night. Entrance was gained through a rear window, and 18 revolvers, 12 watches and two pairs of cuff buttons were stolen.

The next meeting of the Indianapolis Retail Jewelers' Association will be held at the Commercial Club, on the evening of May 4. There is no special program, but business questions of interest will be discussed.

M. C. Winsor, Somerville, Mass., has been appointed a salesman for the South Bend Watch Co., in the New England States. He recently made a trip to the factory at South Bend. His headquarters will probably be located in Somerville.

Extensive alterations are being made by Emil Mantel to his store in W. Washington St. Mr. Mantel recently doubled the size of his establishment, and the alterations now being made will make the store one of the largest and best equipped in the city.

George O. Hoffman, Bunker Hill, has an old clock that stands nine feet high, runs with one weight and registers the day of the month in addition to the minutes and hours. It is believed that the clock was manufactured in England in 1742.

President J. P. Mullally, of the Indianapolis Retail Jewelers' Association, is now sending out copies of the following resolution adopted by the local association: "Resolved, That we as members of the Indianapolis Retail Jewelers' Association agree to make a charge of a minimum of \$1 for all valuations of \$50 or under, and two per cent. for all higher valuations."

Omaha.

L. A. Borsheim has returned from a trip to Sulphur Springs, Ark.

C. L. Shook, of the Shook Mfg. Co., left last week on a business trip to Denver, Colo.

S. W. Lindsay presented the Boy's Department of the Y. M. C. A. with a clock, last week.

Fred Brodegaard, president of the Benson Improvement Club, will give a banquet to all the county officials, at Brodegaard's Hall, in Benson, May 1.

Albert Edholm supplied the handsome sterling silver loving cup which was presented to Albert Morrison, leading man of the Woodard Stock Co., on Saturday, April 18.

S. H. Ledden, Sedan, Kans., has moved his stock of jewelry to Altus, Okla.



THE ABOVE CAN BE HAD IN GOLD PLATE, STERLING AND 14K. GOLD. CUTS ILLUSTRATE A FEW OF OUR HAND-ENGRAVED COMBS.

The Comb House

WE beg to call your attention to our fine line of new, Exclusive and Artistic Combs, both plain and mounted in Genuine and Imitation Tortoise Shell. We manufacture Combs exclusively in 14kt., 10kt., Sterling and Gold Filled.

SELECTION PACKAGES SENT TO RELIABLE JEWELERS

WAGNER COMB MANUFACTURING COMPANY *Hartford Building*
41 Union Square, New York

The "SECURITY" Necklace Clasp

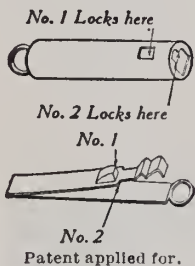

HEAR IT SNAP
Absolutely Secure and Simple. Cannot Pull Out
LOCKS IN TWO PLACES
Making it Doubly Secure
The Only Perfect Clasp

Ask Your Jobber or Write.

PRICES TO THE TRADE:

No. 1	10-Karat.	\$6.00 doz.
"	1-B. 10	7.00 "
"	1. 14	7.00 "
"	1-B. 14	9.00 "
"	2. 10	9.00 "
"	1. Platinum.	18.00 "
"	1. Gold Filled.	2.00 "
"	1-B. "	2.25 "
"	2. "	2.50 "
"	1. Sterling Silver.	2.00 "

The Hoffman Novelty Co.,

Makers, 79-83 No. Pearl St., ALBANY, N. Y.

"CLINCH"



Safety Catch for Scarf Pins

Does not mar the pin. Nothing to get out of order. Simple and neat.

One turn to the right grips like a vise.

..FITS ANY SIZE PIN..

Patent applied for.

PRICES TO THE TRADE

No. 1	Gold Plated	\$1.50 doz.
No. 2	Roman Gold	2.00 doz.
No. 2	14k G'ld Pl'te	2.25 doz.

No. 1, 25c.

STORE AND LOFTS FOR RENT

COMMERCIAL BUILDING

291-293 Seventh Avenue
Near 27th Street



New and Fireproof
10-story Store and Loft Building
Passenger and Freight Elevators
Steam Heat, Electric Power
Finished Walls, New Plumbing
Choice Location for Manufacturing
Near New Penn. R.R. Depot

C. F. BEDELL CO.
BROADWAY and 71st STREET
Telephone, 6000 Columbus

"Gems and Precious Stones"

Their CHARACTERISTICS, LOCALITIES OF PRODUCTION, TESTS and some CURRENT LITERATURE

A New Book on a New Plan. Tabulated, Concise, Authoritative.
A Handy Manual for Every Jeweler.

Cloth, Postpaid, \$1.00

PUBLISHED BY

THE JEWELERS' CIRCULAR PUBLISHING CO., 11 John St., New York

San Francisco.

There is a scarcity of first-class watchmakers here and all along the Pacific coast.

Fred Sheridan, eastern representative of J. S. Lehrberger & Co., was on the coast recently.

Henry Wurfkheim is now associated with his brother, S. Wurfkheim, in the wholesale trade in this city.

Harry Jacoby, Oroville, Cal., was in this city last week attending a meeting of the Grand Chapter of the Masons.

C. E. Innes and L. Plannondon, with the Henry M. Abrams Co., are making their regular trips through the State.

Ben Nordman, of Nordman Bros., who has been ill for over a week, is now recovered and again in his office.

Chas. A. Bransted, formerly with Hammersmith & Co., but now with the house of Walter Ford, Goldfield, Nev., is spending the week in this city.

J. J. Valentine, with A. I. Hall & Son, has just returned from a good trip through the northern part of California and will leave shortly for Eureka, Cal.

Jos. T. Brennan, with Burr W. Freer, this city, is on his regular trip through the south, while J. J. Alexander, with the same firm, is making the northern coast territory.

T. Lundy, who was in a critical condition from the shock he received after the robbery of his store, is much improved. No clue to the robbers has yet been found by the police.

The Jewelers' Board of Trade of the Pacific Coast has secured headquarters in the Monadnock building, which are now open and under the charge of Benj. Armer, secretary of the organization.

A. W. Huggins, president of A. I. Hall & Son, San Francisco, left, April 16, for New York. He expects to be in the east, for a month or more, ordering new lines which the firm intends to carry.

On May 1 the Sorensen Co. will discontinue its Fulton St. store, and the stock will be added to its large store at 715 Market St. The general move of business down town has rendered the keeping of two stores unnecessary.

J. A. Catanich and Lester Hammersmith, both with Hammersmith & Co., have purchased an old street car at Carville on the beach, and every morning they lead the simple life by taking gymnastic exercises and a plunge in the surf.

The ball team of the wholesale jewelers of San Francisco was again victorious last week, defeating the "Alpines" of this place by a score of 8 to 6. H. Wurfkheim, of Wurfkheim & Co., and Mr. Aurich, of Nordman Bros., are the battery for the team.

Among the out-of-town jewelers who visited the local trade during the past week were: M. Landecker, St. Helena, Cal.; Peter Christian, Santa Clara, Cal.; Louis C. Koberg, Healdsburg, Cal.; Chas. Niner, Pleasanton, Cal.; Jere. J. Wilson, Dunsmuir, Cal.

At an elaborate church wedding at Grace Church, April 29, Miss Evelyn Levkowitz, of Alameda, daughter of Dr. and Mrs. M.

W. Levkowitz, of 1204 Grand St., became the bride of Sterling Beckwith Hubbard, of Cleveland, O. The ceremony was per-

formed by D. C. Gardner, chaplain of Stanford University.

Hammersmith & Co. have been conducting a most successful removal sale for the past month, preparatory to moving into their new quarters in the Hammersmith building at the corner of Sutter St. and Grant Ave. This company will carry a much larger line after its removal. John A. Hammersmith, of Hammersmith & Co., is to be ring-master at the Shriners' circus, to be given for the benefit of San Francisco charities, early in May.

Kansas City.

Morris Cohn, Cripple Creek, Colo., is in this city, looking after his business interests here.

August Weber, with Nevin Bros., spent a week recently at his home in Lawrence, Kans.

F. J. and E. P. Nevin, of Nevin Bros., are back from a week's outing at McAllister Springs, Mo.

George Krieke, of the Hassig & Krieke Jewelry Co., is away on a 10 days' trip through Oklahoma.

Leslie White, traveling representative for Ward & Crellin, is in town replenishing his trunks preparatory to another trip.

W. McCluskey and J. D. Sexton have bought McDonald's jewelry store at Newtown, Mo. The new proprietors are former students of the Kansas City Polytechnic Institute.

Mrs. Anna Levin, mother of A. J. Levin, a retail jeweler at 934 Main St., died Wednesday, April 15. She was 85 years of age and had lived in Kansas City 21 years until a few years ago.

Burglars broke into the retail jewelry store of the Guarantee Jewelry Co., 1021 Main St., about a week ago and stole 20 watches and \$150 in cash. The local police believe they have a clue to the thieves.

The following out-of-town jewelers were in town during the past week: T. S. Terry, Downs, Kans.; Dr. J. W. Phillips, Chanute, Kans.; R. R. Smithers, Cameron, Mo.; A. Buchmann, Clay Center, Kans.; W. H. Horn, St. Joseph, Mo.; Carl Ricker, Emporia, Kans.; Geo. Weisgerber, Salina, Kans.; C. J. Keil, Clinton, Mo.; C. D. Hunt, Garnett, Kans.

St. Louis.

The F. Dienstbier Jewelry Co. has been incorporated with a capital stock of \$20,000. The incorporators are: F. Dienstbier, Geo. E. Benz and G. E. Benz, Jr.

The Diamond Investment Co. has been incorporated in this city with a capital of \$3,000. The incorporators are: H. A. McCorkle, J. Summit and Charles Dosworth.

Albert Perkins, of 4410 Washington Boulevard, this city, filed a petition in bankruptcy in the United States District Court, last week. His assets are scheduled as \$14,057 and his liabilities as \$29,725.

A tramp, one afternoon last week, threw a large stone through a heavy plate glass showcase in the store of the Mermod, Jacard & King Jewelry Co., St. Louis, Mo., and thrusting in his hand, snatched two watches valued at \$255. He was caught just as he was about to make off with the

timepieces. At the Central District police station the prisoner gave his name as Jos. Neidhart, 32 years of age, and said he lived at 1110 N. 3d St.

Association Notes.

R. C. Bernau, Greensboro, N. C., and F. M. Jolly, Raleigh, N. C., respectively president and secretary of the North Carolina Retail Jewelers' Association, are sending out notices to the jewelers of their State announcing that the next annual meeting of the association will convene in the Chamber of Commerce, Raleigh, N. C., May 14, 1908, at 9.30 A. M.

President A. C. Gaul, of the Pennsylvania Retail Jewelers' Association, announces that the annual meeting of the association probably will be held in Philadelphia this year. It has not been definitely determined just when the meeting will be, but it will probably be in August. Just what will be considered at the annual meeting has not been determined, but there will be a number of interesting questions discussed. The holding of the convention in Philadelphia will enable the delegates to take a run down to Atlantic City and New York, and it is believed that quite a delegation can be induced to go east, provided the meeting is held during the vacation season.

The seventh annual meeting of the Tennessee Optical Society will be held in Chattanooga, July 7, 8 and 9. The Tennessee Retail Jewelers' Association will hold its annual meeting at the same time. The forenoon of the first and all of the second day will be taken up by the optical society. The jewelers will meet on the afternoon of the first and forenoon of the last day. The evening of July 7 and afternoon of July 9 will be devoted to entertainment of the visiting members by the local optometrists and jewelers. All the optometrists in the State are invited to be present. Chattanooga is an historical place and offers to visitors many points of interest and of amusement to visit. Reduced railroad rates will be in effect. Manufacturers and jobbers are invited to be present and have exhibits.

Milwaukee.

Thomas Cunningham, who attempted to pass a forged check on Richard Seidel, jeweler, Grand Ave. and 2d St., has been sentenced to the house of correction for a term of one year.

W. H. Upmeyer, of Bunde & Upmeyer, has just returned from a six weeks' trip with George H. Mayer through Dixieland, Cuba and Mexico. Mr. Upmeyer expresses himself as much impressed with the scenes in these countries. He is much improved in health.

The Milwaukee Jewelers' Club held its monthly banquet at the Hotel Blatz, Wednesday, April 22. George Durner, Jr., president, presided. Among the topics discussed was the street clock question in Milwaukee. The annual meeting will be held May 13, at which time officers will be elected. The club is nearly two years old and its membership embraces nearly every active jeweler in Milwaukee.

Warning to the Trade

"HOLD-ON" CLUTCHES

 WE are the sole and exclusive licensees for use in jewelry under Patent No. 700,412, dated May 20, 1902, granted to Max H. Fischer for Clutches. This is a broad, comprehensive patent for clutches under which patent we have manufactured and sold our "HOLD-ON" clutches for scarf pins, etc., for many years past.

We have brought suit in the United States Circuit Court for the Southern District of New York against various concerns and persons for patent infringement, unfair trade and imitation of our clutches and for FORTY THOUSAND DOLLARS (\$40,000) damages.

We have also brought suit in the same court for the infringement of said patent against another concern having lately placed another similar device on the market, and we will also bring suit against all others who make, sell or offer for sale any clutch infringing upon our patents covering the manufacture of the Hold-On Clutch.

We are informed by our counsel that the claim of these parties that their clutches are made under patents does not excuse the infringement, as they are ALL LATER than the Fischer invention.

All dealers are hereby warned that the making, selling, using or otherwise handling any of the above devices except through us, will be deemed an infringement of our rights, for which suit for infringement and damages will be immediately brought, and WORTHLESS GUARANTEES will not avail dealers who handle such goods.

It is our intention to vigorously prosecute all infringements of the patent and trade rights and to protect our rights by every means in our power.

Hold-On Clutch Company
C. P. GOLDSMITH & CO., Proprietors



G. L. Krentz has opened a store at Donald, S. Dak.

The J. S. Sandoz Co. has been incorporated in Philadelphia, Pa., to manufacture watches.

Ralph Simpson, formerly of Wahoo, Nebr., has engaged in the jewelry business at Falls City, Nebr.

The Seeright Spectacle Co. is a new firm in Portland, Me., where the concern has an office at 570½ Congress St.

Abelson & Co. have engaged in the instalment jewelry business in the Chicago Savings Bank building, at Chicago, Ill.

The A. E. Schunk Co. has been incorporated in Milwaukee, Wis., with a capital stock of \$15,000, to sell jewelry, dry goods, etc.

The Diamond Investment Co., St. Louis, Mo., has been incorporated with a capital stock of \$3,000. The incorporators are: H. A. McCorkle, J. Summit and Charles Dsworth.

The G. H. P. Stone Co., Fulton, N. Y., has been incorporated at that place to deal in watches, jewelry and diamonds, with a capital of \$2,000. The incorporators are: Geo. H. P. Stone, E. H. Luke and Clara M. Stone.

J. Henry Smith, Indianapolis, Ind., has organized the J. Henry Smith Co., at Greenfield, Ind., with a capital of \$2,500. The stockholders are: J. H. Smith, Wilhelmina Smith and George R. Bodine. The company will do a jewelry business.

Pacific Northwest

Dr. T. A. Birtch, oculist, has opened an office in Seymour Jacobs' store, at Elko, Nev.

Carl Adler, Baker City, Ore., has returned from the east, where he has been purchasing stock.

J. C. F. Collins, Lynden, Wash., has sold his business to Mr. Cruikshank and will move to Twin Falls, Idaho, where he will start in business as soon as a good opening is found.

Savannah, Ga.

Theus & Co. have on exhibition the silver cup which was designed by them for the Savannah Challenge Trophy, and won in the automobile race last March by the makers of the Isotta Froschini car.

M. Sternberg has filed suit in the City Court of Savannah against the Southern Express Co. for \$400, the value of a diamond ring sent to Mrs. J. Coburn, Daytona, Fla., C. O. D., which she refused to accept. The ring is said to have been lost or stolen in transit from Daytona to Savannah.

The jewelry store of J. A. Robinson, Whitefish, Mont., has been destroyed by fire.

INDEX TO ADVERTISEMENTS.

Alkin-Lambert Co.	112	Gorhau Co.	70	Penfold, Wm. C., Co.	92
Allsopp Bros.	55	Griffoul, August	112	Peninsular Eng. Co.	19, 20
Alvin Mfg. Co.	Inside front cover	Gugenheim, M.	40	Pitcairn, W. S.	112
American Gem & Pearl Co.	54	Ilagstoz, T. B., Ltd.	115	Potter, E. A., Co.	22
American Platinum Works	114	Hammel, Riglander & Co.	S. 23	Potter & Buffinton Co.	37
American-Swiss Watch Co.	102	Harris & Harrington	102	Prior, Charles M.	37
American Watch Case Co.	102	Hedges, A. J., & Co.	33	Purdy, Chas. S., Co.	64
Archibald Klement Co.	34	Hedges, Wm. S., & Co.	62	Racine, Jules & Co.	102
Arnstein Bros. & Co.	48	Heller, L., & Son.	54	Randall, C. Ray	24
Arnstine Bros. Co.	80	Herpers Bros.	105	Ranlett & Lowell Co.	112
Arizona Turquoise Mines Co.	52	Hill & Schmidt	31	Reichhelm, E. P., & Co.	108
Attleboro Chain Co.	77c	Himalaya Mhuing Co.	56	Reichman, A.	65
Austin, John, & Son.	108	Hodenpyl & Walker	58	Renziehausen, W. F., & Co.	114
Austin & Stone	14	Hoffman Novelty Co.	84	Revell, A. H., & Co.	116
Bagg & Co.	60	Hold-On Clutch Co.	86	Richards, J. M.	64
Baker, Geo. M.	114	Holmes & Edwards Silver Co.	29	Richards, W. E., Co.	36
Ball, Webb C., Watch Co.	103	Hooper, H. J.	82	Richardson, Enos, & Co.	33
Barrows, H. F., Co.	58	Hotel St. James	110	Robbins, Chas. M., Co.	39, 69
Baschkopf, Henry	35	Hraba, Louis W.	114	Roger Williams Silver Co.	40
Bassett Jewelry Co.	31	Hull Bros. Umbrella Co.	82	Rohrbeck, John E.	32
Bates & Bacon	18	Hllnois Watch Co.	78	Roseman, A.	64
Bedell, C. F., Co.	84	International Gem Co.	58	Rothschild Bros. & Co.	32
Berge, J. & H.	114	International Silver Co.	29	Roy Watch Case Co.	103
Billings, Chester, & Son.	58	Irons, Joseph	36	Rudolph & Snedeker	103
Bishop, R. W.	114	Irving Cut Glass Co.	110	Rumpp, C. F., & Sons.	114
Blackinton, R. & Co.	27	Jacot Music Box Co.	119	Saunders, Meurer & Co.	62
Bolles, Wm., Co.	115	Janitschek Co.	108	Schlehr, Louis G.	34
Borrell & Vitell	66	Jeanne, F. A.	62	Sessions Clock Co.	102
Bowden, J. B., & Co.	35	Juergensen, Jules	103	Simmons, R. F., Co.	28
Bradley Polytechnic Institute.	41	Kahn, L. & M., & Co.	48	Smith, Alfred H., & Co.	52
Briggs, D. F., Co.	22	Keller Jewelry Mfg. Co.	32	Smith, Frank W., Co.	26
Briggs Piano Co.	116	Kent & Woodland	30	Smith, Wm., & Co.	36
Bruhl Bros. & Henius Co.	50	Ketcham & McLougall	41	Smith & Crosby	21
Carter, Howe & Co.	31	Keystone Watch Case Co.	98	Snow & Westcott Co.	32
Chatham National Bank	74	Kirby, H. A.	72	Solidarity Watch Case Co.	26
Chicago Art Metal Works	40	Kohlbusch, Herman, Sr.	114	Spencer, E. L., Co.	37
Chopard Frères Co.	66	Kohn, Alois, & Co.	32	Star Watch Case Co.	6
Cincinnati Gold & Silver Refining Co.	68	Kremetz & Co.	12	State Bank	74
Conley & Straight	115	Larter & Sons	46	Stelner, Louis	110
Cottle, S., Co.	31	Lederer, S. & B., Co.	38	Stein Bros. & Co.	62, inside back cover
Crees & Court	108	Leiman Bros.	108	Stern & Corn.	41
Crohn, M.	35	Lelong, L., & Bro.	114	Sternau, S., & Co.	19
Cross & Bequelin	72	Lewy & Cohen	35	St. Louis Watchmaking School	103
Crossman Co.	52	Lissauer & Co.	64	Street, Geo. O., & Sons.	34
Cronch & Fitzgerald	112	Lorsch, Albert, & Co.	48	Sussfeld, Lorsch & Co.	39, 54, 110
Day, Clark & Co.	30	Lowe, Edwin, & Co., Inc.	38	Swartchild & Co.	92
Deacon, Louis J.	31	Mable, Todd & Co.	41	Tavannes Watch Co.	92
Dederick's, James H., Sons.	108	Maiden Lane Realty Co.	75	Title Guarantee & Trust Co.	74
De Simone, F., & Son.	32	Maintien Bros. & Elliot	40	Trout, Charles L., & Co.	31
Dixon, Wm., Inc.	115	Market & Fulton National Bank	74	Untermeyer-Robbins Co.	68
Doran, Bagnall & Co.	38	Marson, A.	114	Urich, S.	64
Dorflinger, C., & Sons.	110	Mason, Howard & Co.	69	U. S. Smelting & Refining Works.	115
Draper, O. M., Estate.	42	Mercantile National Bank	60	Van Dam, Eduard	50
Dubois Watch Case Co.	94	Merrill, S. K., Co.	54	Van Dusen & Stokes Co.	25
Dueber-Hampden Watch Mfg. Co.	10	Miller, Fuller & Whiting Co.	40	Wachenheimer Bros.	37
Dunn, T. J., Co.	112	Mount & Woodhull.	60	Wadsworth Watch Case Co.	9
Durand & Co.	30	Myers, J. A.	59	Wagner Comb Mfg. Co.	84
Elchberg & Co.	66	Myers, S. F., Co.	36	Waite-Thresher Co.	42
Eisenmann Bros.	58	New England Watch Co.	101	Waldron & Carroll	38
Elgin National Watch Co.	96	New Haven Clock Co.	101	Waltham Clock Co.	103
E. P. H. Chain Catch.	62	New York Standard Watch Co.	100	Washburn, C. Irving	36
Fabys, Joseph, & Co.	3	New York Tortoise Shell Co.	112	Wells, Chester H.	35
Feldenheimer, Louis	66	Nissen, Ludwig, & Co.	60	Wendell & Co.	7
Fontneau & Cook	11	Noel, Rudolph & Co.	62	Wheeler, Hayden W., & Co.	52
Foster, Theodore W., & Bro., Co.	44	Oneida Community, Ltd.	15, 16, 17, outside back cover	Whiting & Davis	23
Freund, Henry, & Bro.	24	Oppenheimer Bros. & Veith.	50	Whiting, F. M., & Co.	25
Friedlander, R. L. & M.	50	Oskamp-Nolting & Co.	62	Whiting Mfg. Co.	13
Garreaud & Griser	38	Osmers-Dougherty Co.	39	Wightman & Hough Co.	36
Gates A. E.	116	Osmun-Parker Mfg. Co.	30	Wolfshelm & Sachs.	34
Gillette Sales Co.	43	Ostby & Barton Co.	21	Wollstein, L. & M.	115
Goldsmith, C. P., & Co.	86	Owanda Cut Glass Co.	110	Wood, J. R., & Sons.	4, 5
Goldsmith, Leo.	52	Papazien, A. D.	103	Zarembowitz, A.	114
Goodfriend Bros.	64				

Special Notices.

Situations Wanted.

WANTED, position in jewelry store by first class engraver. Address "A. F., 3819," care Jewelers' Circular-Weekly.

WANT WORK on watches and clocks, wait on trade. Address "F. L., 4136," care Jewelers' Circular-Weekly.

FIRST CLASS platinum worker, all around man, wants position, at once. Joe Satlow, 100 E. 7th St., New York.

WATCHMAKER and engraver, 30 years' experience, no jewelry repairs; good references. J. Lane, 1650 N. Clark St., Chicago, Ill.

FIRST CLASS watchmaker can take position at once in New York City or vicinity. "W. T., 4140," care Jewelers' Circular-Weekly.

CLOCKMAKER, with tools and references; can do watchwork, nothing else. Address "W. J. S., 4092," care Jewelers' Circular-Weekly.

FIRST CLASS watchmaker, with own lathe and tools, prefer a position in Greater New York. Address "I., 4067," care Jewelers' Circular-Weekly.

WATCHMAKER and jewelry repairer wishes position in south or west, at once; good reference. Address "B., 4044," care Jewelers' Circular-Weekly.

AT ONCE, by German, all around man, watchmaker, jeweler, engraver, stone setter, colorer, etc.; go anywhere. Lambert, 169 E. 128th St., New York.

POSITION WANTED by young man as assistant watchmaker and engraver; good references; own tools. Address "N., 4107," care Jewelers' Circular-Weekly.

FIRST CLASS engraver, salesman and window dresser wants permanent position with reliable firm; best references. "G.," 129 N. Perry St., Johnstown, N. Y.

ENGRAVER, salesman, window dresser and useful young man, desires permanent position with a growing concern. Walter Hohl, engraver, 321 E. 83d St., New York.

ENGRAVER, 15 years' experience on first class monogram and inscription work on silverware and jewelry; city or country. "C., 4088," care Jewelers' Circular-Weekly.

YOUNG MAN, 25, wants to travel for manufacturer or jobber on commission basis with real diamond or imitation goods. "Y., 4121," care Jewelers' Circular-Weekly.

ENAMELER, experienced on all kinds of work, emblems, class pins, lodge rings, jewels, etc.; capable of taking charge. "Hustler, 4137," care Jewelers' Circular-Weekly.

WATCHMAKER, with vast experience in repairing all grades of watches, desires a position with a house of the first magnitude. W. T. Gardner, 137 S. Duke St., Lancaster, Pa.

YOUNG MAN, 28, desires position as salesman and window dresser; can do plain watchwork, jewelry and clock repairing. "M. D., 4074," care Jewelers' Circular-Weekly.

YOUNG MAN, neat appearance, wishes position as salesman in retail jewelry store; five years' experience; A1 references. Address "T., 4009," care Jewelers' Circular-Weekly.

FIRST CLASS watchmaker, with tools, desires position at once; good references; competent to handle railroad work. Address "Watchmaker," 45 Charles St., Springfield, Mass.

BOY of 16 desires position where he can learn watchmaking or engraving or both; can furnish excellent reference from former employer. Henry Ruzicka, 317 E. 70th St., New York.

MAN, 43 years of age, having 20 years' experience in the jewelry business as jobber, desires a position; best of reference. Address "Rosenfeld," care Cohn, 167 Suffolk St., New York.

A GOOD WATCHMAKER and clock repairer, expert on complicated Swiss watches, capable to do easy jewelry work, desires a position. Address Chas. Weimer, care Post Office, New York.

SITUATION WANTED with jobber or manufacturer, to represent in the middle west; best of reference; good address and hustler. Address "J., 4086," care Jewelers' Circular-Weekly.

WATCHMAKER wishes position; can do clock and jewelry repairing, and can assist at counter; 14 years' experience; best references. "Watchmaker," 120 Middleton St., Brooklyn, N. Y.

WATCHMAKER of 20 years' experience on high grade watches and accustomed to serve on high class trade, desires good position with first class jewelers. "M.," 22 Moreland St., Roxbury, Mass.

ONE of the most thorough workmen in the south desires position with first class house appreciating fine service; can manage entire business. "Reliable, 3965," care Jewelers' Circular-Weekly.

SITUATION WANTED by first class manufacturing and jobbing jeweler, also stone setter and all around man, with best of references. Address "M., 4011," care Jewelers' Circular-Weekly.

WATCHMAKER, first class, with own lathe and tools, wishes position in first class store; will start for small wages; talk English and Swedish. Address "X., 4127," care Jewelers' Circular-Weekly.

HIGH GRADE, competent watchmaker, all around man, desires to make a change; 25 years' experience; A1 references. Henry Paulson & Co., Material House, Chicago, Ill., and San Francisco, Cal.

YOUNG MAN, good engraver, desires position; one with a chance to learn watch repairing preferred; samples of engraving and references furnished. Address "Y., 4078," care Jewelers' Circular-Weekly.

YOUNG MAN wants position as assistant watchmaker under good man; 3½ years' experience on watches, clocks and jewelry; single; best of reference. Address "L., 4132," care Jewelers' Circular-Weekly.

FIRST CLASS watchmaker, with 25 years' experience on all Swiss, English, American and complicated watches, wants position; best references; good salary. Address "U., 4125," care Jewelers' Circular-Weekly.

SALESMAN of precious stones, with 10 years' experience among New York, Newark, eastern and New York State trade, desires position; good references. Address "W., 4112," care Jewelers' Circular-Weekly.

WATCHMAKER, age 30, single, American, temperate, 12 years' experience, competent on railroad work, plain engraver, desires permanent position; salary, \$18. "W., 4091," care Jewelers' Circular-Weekly.

ENGRAVER, young man, desires position with first class engraver, or an opportunity to learn watch work; good script letterer; samples on request; A1 reference. "D., 3802," care Jewelers' Circular-Weekly.

FIRST CLASS watchmaker, thoroughly competent on high grade Swiss and American watches; age 30; 15 years' experience; gentleman of good habits; no cheap house need apply. "S., 4104," care Jewelers' Circular-Weekly.

WATCHMAKER, jeweler, optician and salesman, age 40, 20 years in business for himself, wishes a change; would like to engage with someone for the Summer at least. Address "A. E., 4120," care Jewelers' Circular-Weekly.

WATCHMAKER and refractionist of ability, expert frame shaper, rimless mounter, diamond setter; good address and appearance; open for position at once; references. Address "D., 4082," care Jewelers' Circular-Weekly.

FIRST CLASS jeweler on gold and platinum work, setter and plain engraver, an all around workman, wishes position in shop or factory; best of references furnished. Address "K., 3998," care Jewelers' Circular-Weekly.

WATCHMAKER wishes position May 11; age 22; six years' experience; can repair jewelry; New York City preferred; have American lathe and full set of tools; best references. Albert Sondhelm, 167 E. 94th St., New York.

FOREMAN, manufacturing general line of gold and platinum jewelry; good mechanic with executive ability, experienced in all the details of managing a jewelry factory. Address "Adaptable, 4072," care Jewelers' Circular-Weekly.

BOOKKEEPER, charge of stock, filling orders, selling; young woman, eight years in wholesale jewelry business, having entire charge; excellent reference; would leave town. Address "G., 4142," care Jewelers' Circular-Weekly.

WATCHMAKER wishes position with good house; American, 34 years of age; accustomed to taking in and delivering work and fine trade, also can act as salesman; familiar with railroad work and inspection service; write full particulars in first letter. Address "W., 4135," care Jewelers' Circular-Weekly.

WANTED, position as buyer, assistant buyer or salesman; can furnish best of references for eight years' experience in silver plated flat and hollow ware lines. Address Wm. Tollner, care Tift Bros., Produce Exchange, New York.

SITUATION WANTED by young man as watchmaker or assistant watchmaker, jewelry repairing, clock work, stone setting, wait on trade, etc.; experience on railroad work, own tools; A1 reference. Oscar B. Corman, Bloomington, Ill.

WATCHMAKER, 45, first class worker, experienced in all kinds, best city references, good appearance, wants position with good firm; will go anywhere; present location Chicago, Ill. "Reliable, 4100," care Jewelers' Circular-Weekly.

TRAVELING SALESMAN; thoroughly experienced salesman, with unquestionable references, desires a factory line of gold jewelry, to travel between St. Louis and the western coast. Address "S. L.," 1112 Main St., Kansas City, Mo.

JEWELER, experienced on fine platinum mountings, gold work and all around man, have worked eight years in New York and four in the west, desires steady position; town or country. Address "Z., 4130," care Jewelers' Circular-Weekly.

FIRST CLASS watchmaker, salesman and graduate optician; 21 years' experience; capable of taking full charge; 36 years old; American; have tools and trial case; state wages; A1 reference. Address "R., 4049," care Jewelers' Circular-Weekly.

WATCHMAKER, 20 years' experience, German-American, age 35; American lathe; understands staffs, cylinders, pivots, railroad watches; can take full charge; no bad habits; best reference. Address "F., 4098," care Jewelers' Circular-Weekly.

SALESMAN, well acquainted with trade in New York City, Boston, Philadelphia, Baltimore and Washington, who can produce results with manufacturer or jobber, wishes position; excellent references. "O., 4083," care Jewelers' Circular-Weekly.

COMPETENT WATCHMAKER, salesman and plain engraver desires permanent position with first class firm; experienced on high grade work; sober and reliable; good appearance; good habits and references. "P., 4084," care Jewelers' Circular-Weekly.

A FIRST CLASS, all around jeweler, 18 years' experience at fine diamond mountings, special order work, repairing and stone setting, wishes position; best references; city or country; state salary willing to pay. "P., 4131," care Jewelers' Circular-Weekly.

YOUNG, all around watchmaker, engraver, optician and salesman, 12 years' experience in business, having tools and reference, wants position at once; New York City or vicinity; of recent years manager and buyer. "M., 4081," care Jewelers' Circular-Weekly.

WATCHMAKER and engraver, who is a first class watchmaker and does nice, neat engraving, desires a permanent position; have tools and good references; 27 years old, single, American; locality of good position no objection. "J., 4077," care Jewelers' Circular-Weekly.

A1 WATCHMAKER, graduate optician, fine letter and monogram engraver; 23 years' experience; do not repair clocks or jewelry; modern tools and trial case; would not go east of Indiana; \$18 to \$20; first class references. Address "C. W., 4116," care Jewelers' Circular-Weekly.

Help Wanted.

WANTED, young lady about 16 years old for office work; best reference only. "H., 4122," care Jewelers' Circular-Weekly.

NEW YORK CITY retail jewelry house desires competent watchmaker. Address "R., 4106," care Jewelers' Circular-Weekly.

WANTED, watchmaker and salesman for Maiden Lane, New York City. Address "Permanent, 4124," care Jewelers' Circular-Weekly.

WANTED, watch case repairer; state age, experience and by whom you were last employed. Address Drawer No. 1127, Kansas City, Mo.

WANTED, first class watchmaker and engraver; wages, \$20 per week; regular job if satisfactory; give reference. The Little-Long Co., Charlotte, N. C.

WANTED, experienced watchmaker, fair engraver, jeweler and salesman, in a town near New York; permanent position to right man; must have reference; \$23 to start with; chance for advancement. Address "Connecticut, 4117," care Jewelers' Circular-Weekly.

HELP WANTED.—Continued.

SALESMAN; affinity jewelry, the latest fad; if you want a good side line address me at once. Paul Gougelman, Room 27, 37 Maiden Lane, New York.

FIRST CLASS watchmaker and diamond setter; permanent position to a sober, reliable, energetic man. Address, with reference, Box 358, Charleston, W. Va.

WANTED, at once, watchmaker and engraver, competent to do railroad work, young man preferred; position permanent to right man. R. Heine, Talladega, Ala.

WANTED, a first class diamond, watch and jewelry salesman, a young man with experience; must come well recommended; will pay a good salary. "V., 4111," care Jewelers' Circular-Weekly.

WANTED, an experienced stockkeeper and salesman for our wholesale department; must come well recommended. Apply to Ben Linz, of Linz Bros., Dallas, Tex., at Keystone Office, Chicago, May 6 to 8.

WANTED, young man, who is a good salesman and can make himself generally useful around store; first class references required; state salary and references. R. G. Winter Jewelry Co., Minneapolis, Minn.

WANTED, an experienced man who can do good watch work and nice engraving and is a good salesman; situation in New York State; good salary. Address "Jeweler, 3960," care Jewelers' Circular-Weekly.

WANTED, at once, a first class watchmaker and engraver; if you are looking for a permanent position at good wages write us, sending photo, sample of engraving and reference in first letter. Tillson Jewelry Co., Carrington, N. Dak.

WANTED, optical buyer and manager; must have had experience in same capacity and understand getting up catalogue; address, stating experience, salary expected and full particulars. Otto Young & Co., Heyworth Building, Chicago, Ill.

WE HAVE a position open for a good, active, reliable man who understands the pawnbroking business thoroughly; must be a good salesman and understand values in general; salary no object; full particulars in first application. Goldwater's, 841 Broadway, Oakland, Cal.

AT ONCE, good, experienced watchmaker, one who is fair engraver and jewelry repairer; first class references from last employer and sample of engraving in first letter; position permanent and reliable; salary, \$20 per week to start; if satisfactory will raise. Address "R., 4063," care Jewelers' Circular-Weekly.

Business Opportunities.

FOR SALE, jewelry business; invoice, \$2,500, with new fixtures, wall case, etc.; established seven years; large repair trade. Address Crosby Co., Darlington, S. C.

JEWELRY STORE for sale in Brooklyn; good repair trade; small stock; will sell with or without stock; reasonable. "P., 4115," care Jewelers' Circular-Weekly.

FOR SALE, one of the best high class jewelry stores in New York State; fine repair and optical departments; business, \$25,000 annually. Address "E., 4093," care Jewelers' Circular-Weekly.

BEST LOCATION in Philadelphia, reasonable; good paying retail jewelry store; ill health compels me to retire. For further information address Max Mayer, 942 Market St., Philadelphia, Pa.

\$1,000 WILL BUY an old established jewelry store in South Brooklyn, N. Y.; a splendid opportunity for a good man; reason for selling, other business. Address "V., 4033," care Jewelers' Circular-Weekly.

FOR SALE, fine jewelry store; best location in Elmira, N. Y.; inventory, stock and fixtures, \$4,000, can be reduced; wish to retire, reason for selling. Inquire "D. H. S.," 137 Sullivan St., Elmira, N. Y.

HIGHEST cash prices paid for watches, diamonds and jewelry; quick and liberal returns; all business confidential; bank references. E. Noel, 552 E. 46th Place, Chicago, Ill., Telephone Blue, 995.

FOR SALE, on monthly payments, new and complete electroplating outfit, equipped for nickel, silver and gold plating and polishing; cheap power and loft; call between 4 and 6 P. M. daily. Atwater & Bario, 64 John St., New York.

JEWELRY STORE for sale; a good opportunity for a practical watchmaker and jeweler to get a good business stand; new stock and fixtures; low rent and good location; write for further particulars. Address E. W. Button, receiver, Parker & Kolb Co., Bridgeport, Conn.

MONEY ADVANCED or buy outright, watches, diamonds and jewelry; moderate charges on loans; strictly confidential; reference, Auburn Trust Co., Auburn, N. Y. Robert J. Benham, Auburn, N. Y.

FOR SALE, jewelry and optical business in small New York State town; 1,500 population; large territory; grape industry; three railroads, trolley system; stock and fixtures (new) about \$2,000; can be reduced; no competition; low rent; fine chance for good workman; other interests reason. Address "A., 4105," care Jewelers' Circular-Weekly.

FINE OPENING for jeweler and optician; established business well advertised; splendid location, front part of store; county seat, 3,000 population in Michigan town; will loan show cases to responsible man and put him next to a fine trade; no stock to sell; don't answer unless you are a capable optician and watchmaker. "V., 4079," care Jewelers' Circular-Weekly.

AN OPPORTUNITY of a lifetime; I have a store 38 years established, doing a fine business in the best jewelry city in the United States; present invoice, \$75,000; will reduce to suit purchaser; long lease, low rent, best location in city, and the leading jeweler of the State; if you mean business answer; ill health the cause of retirement. A. E. Gates, 1 Maiden Lane, New York.

35 YEARS' established wholesale material business for sale, at a bargain; not much cash required; a hustler could make business pay for itself in two years, as the man I am selling it for has made a fortune and must retire on account of old age; house sells goods in 15 States; located in the best city of over 300,000 in the central west; for a golden opportunity address me at once. Dan I. Murray, broker, 3 Maiden Lane, New York; 512 Race St., Cincinnati, O., and 151 Wabash Ave., Chicago, Ill.

DO YOU NEED MONEY? If so, send your diamonds and watches to me and get quick and liberal returns; highest cash prices paid for entire jewelry stocks; will send our representative if necessary; business confidential; National Bank references. H. Schwartz, 807 Chicago Savings Bank Building, Chicago, Ill.

DO YOU WISH TO RETIRE? Why not turn your entire store or surplus stock into cash? We pay the highest prices, also advance liberal cash amounts on stocks; communicate with us before consulting others; we act quick and strictly confidential. Brooklyn Purchasing Syndicate, 608 Broadway, Brooklyn, N. Y., Telephone, 2328 Williamsburg.

FIXTURES; one large size Diebold safe, steel lined and heavy burglar proof inside door, double outside fireproof door, cost \$450, almost new, good condition; four real walnut wall cases, each eight feet long, round glass ends, doors slide up, cupboard in base of one, drawers in others, in good condition; two eight-ft., two six-ft. show cases on walnut tables, fair condition; one six-ft. walnut silent salesman floor case, good condition; one seven-ft. cherry regulator, sweep second, mercurial pendulum; large crystal and spectacle cabinets; bench with countershaft and wheel; polishing lathe; \$300 watch and jewelry material. Address A. B. Regnier, Marietta, O.

To Let.

TO LET, shop at 30 Maiden Lane, suitable for jeweler, etc.; rent, \$15. Vogel, Corby & Wesche, 30 Maiden Lane, New York.

PART of jewelry store to let for optician or cut glass firm; good location. C. Schneider, 2134 Seventh Ave., between 126th and 127th Sts., New York.

TO LET, part or whole of a well equipped jewelry shop and office with full use of most modern machinery. Apply Laubheim Bros., 65 Nassau St., New York.

TO LET, desk room with a prominent manufacturing concern in the new Silversmiths' building, New York. Address "Z., 4032," care Jewelers' Circular-Weekly.

FOR RENT, repair shop in New York City for jobbing jeweler; dynamo and complete fixtures already installed; excellent location and good opportunity for practical man. "Repair, 3956," care Jewelers' Circular-Weekly.

TO LET, third floor of building in Newark, N. J., opposite Market St. station, with steam heat, power and elevator service; size of floor, 115 ft. by 39 ft.; well lighted and specially adapted for manufacturing jewelers. Address Cyrus Currier & Sons, 365 Market St., Newark, N. J.

For Sale.

FOR SALE, one steel lined burglar and fireproof, single door, Marvin safe; weight, 5,400 lbs.; height, 63 ins. x 38 ins. wide x 31 ins. deep; original cost, \$450; will be sold at a bargain. Address W. H. Reisner Mfg. Co., Hagerstown, Md.

FOR SALE, two new 1906 model 1/3 H.P. polishing motors, 220 volts, direct current; regular wholesale price \$69, sell for \$49 each; two new 1906 model 1/5 H.P. polishing motors, 220 volts, direct current; regular wholesale price \$37.50, sell for \$27.50 each; guaranteed for one year against defects. The W. Green Electric Co., 81 Nassau St., New York.

Miscellaneous.

PORTRAIT MINIATURES copied from any photo on watches, dials, brooches and lockets. Goldstein Engraving Co., 45 Maiden Lane, New York.

LEARN ENGRAVING, by the wonderful method of a French-American professor; 30 years' experience; day or evening classes. 30 E. 14th St., New York.

WATCH REPAIRING for the trade; best material used; work done promptly; reference given; give us a trial. P. J. Friedel, 727 Sansom St., Philadelphia, Pa.

EXPERT WATCHMAKER, all around man, looking for location to open fine repair shop; A1 reference. Henry Paulson & Co., Watch Material House, Chicago, Ill., and San Francisco, Cal.

10 TO 20 PER CENT. SAVED!

M. L. Jalonack, jewelry auctioneer and diamond expert, will pay you from 10 to 20 per cent. more for your stock of jewelry, watches and diamonds than any other buyer of stocks. Send me your surplus stock and I will send draft on First National Bank of Chicago. If my price isn't satisfactory I will return the goods on receipt of draft. Consult me about turning your stock into money quickly. All business strictly confidential. Write, call or telephone M. L. JALONACK, 5339 PRAIRIE AVE., CHICAGO, ILL. Long Distance Phone, Gray 5234.

S. F. MYERS BLDG.
47-49 Maiden Lane, N. Y.

For Rent

A few choice, light and very desirable offices

Moderate Rentals

Details of
J. A. MYERS
On Premises

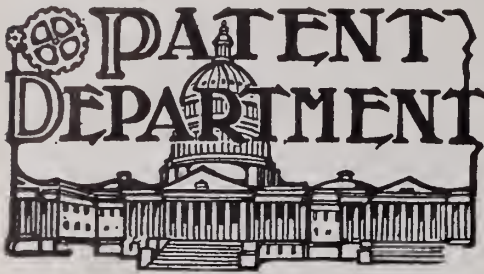

IN WHICH IS CONTAINED A LIST OF THE LATEST PATENTS GRANTED BY THE UNITED STATES AND GREAT BRITAIN, THE UNITED STATES PATENTS THAT HAVE EXPIRED AND THE REGISTERED TRADE-MARKS.

UNITED STATES PATENTS.

ISSUED APRIL 21, 1908.

885,037. PERCOLATOR. ELI S. GLOVER, Chicago. Filed July 9, 1907. Serial No. 382,893.

A percolator comprising a filter holder having a screw threaded extension on the bottom thereof with a port therein, a perforated filter cup disposed above the bottom of the holder and having a threaded collar on the bottom thereof, the bottom

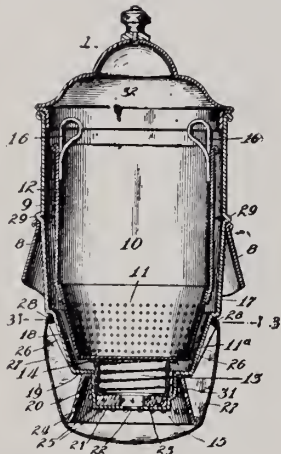

of the cup being imperforate within the threaded portion, said collar being adapted to engage the extension to control the outflow of fluid from the percolator.

885,135. SEPARABLE CUFF LINK-BUTTON. FRANK P. BARNEY, Chartley, Mass., assignor of one-half to Charles D. Lyons, Mansfield, Mass. Filed July 25, 1907. Serial No. 385,405.

As an improved article of manufacture a separable cuff-link button, the same comprising a pair of independent button members each provided with a fixed shank terminating in a lateral flange or enlargement adapted to pass through a buttonhole

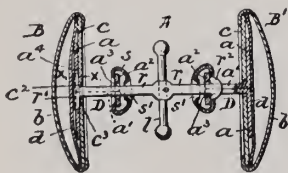

of the cuff and retain said member therein, a swinging coupling member or link mounted in one of the button members and extending longitudinally beyond its flange, and having the free end of said link constructed to engage with the fellow button member for detachably securing them together.

885,149. WATCH CASE. WALTER H. FITZGERALD, New York, assignor of one-fourth to Benjamin A. Bloch, Brooklyn, N. Y., and one-fourth to Emanuel M. Bloch, Sag Harbor, N. Y. Filed Sept. 18, 1907. Serial No. 393,428.

The combination with a one-piece, cup-shaped, back portion, of a screw-bezel watch case having a closed back, of a movable cover attached to said cup-shaped back portion and between which cover

and the back wall of said back portion is formed a chamber or compartment, normally closed by said cover, for holding a photograph or other thin article which may be exposed to view, by opening said cover, without impairing the dust-proof quali-

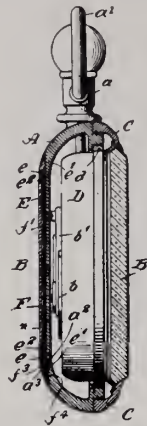

ties of said case, the exterior of said cover forming the rear surface of the case and being so shaped that its contour does not project beyond the natural contour of the said back-piece, so that the thickness of the watch case is not increased by the said exposable compartment.

885,366. WATCHMAN'S CLOCK. ABRAHAM A. NEWMAN, Chicago. Filed Dec. 4, 1906. Serial No. 346,277.

The combination with a casing having an opening for the entrance of a key, of a septum within the case and between the normal position of the

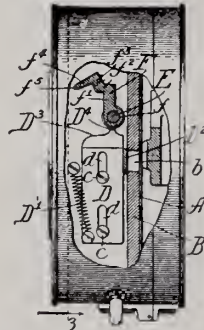

dial and the opening aforesaid, a perforation in the septum, and means normally closing the perforation in said septum and constructed and arranged to be actuated by a key in its movement to uncover the perforation in the septum for the passage of a key.

885,416. COLLAR-BUTTON. HARRY J. WYLYE, Kutztown, Pa. Filed May 18, 1906. Serial No. 317,612.

A button comprising a base including a lateral extension provided at its free end with an upwardly-extending member; a stem secured centrally to said base; a U-shaped retainer having the returned ends of its legs pivoted to said member, said retainer being adapted to be swung into and out of engagement with the stem; and a head piv-

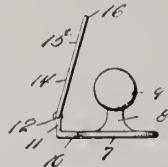

oted to said stem, for movement in a direction at right angles to that of said retainer, directly over the latter when in engagement with said stem, whereby the retainer is held against displacement from said stem.

885,503. STATION-INDICATOR. CHRISTIAN MILLER, Chicago. Filed July 9, 1907. Serial No. 382,923.

The combination of a clock, the case of which has an exterior circumferential outwardly-projecting flange with a series of holes around the same, a ring in front of the clock and having pins

adapted to enter said holes and clips engageable with the flange, and a transparent dial in the

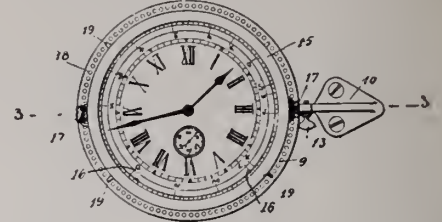

ring and covering the face of the clock, the dial having station marks thereon.

885,513. ELECTRIC TIME-SWITCH. CARL G. NYLANDER and FRANK J. REGENSBURGER, McKeesport, Pa., assignors to the National Electric Time Switch Co., McKeesport, Pa. Filed Oct. 31, 1905. Serial No. 285,302.

In a time-switch mechanism for clocks in combination, a hand arbor, operating means therefor, a pinion on said arbor, a time setting means comprising a rotatable dial having teeth meshing with said pinion and having an exposed face provided with two series of numbers, each series having its numbers ranging clockwise from one to 12, and two plates each having a projecting finger overlying said numbered face, said plates being each rotatable with said dial and also each having rotary

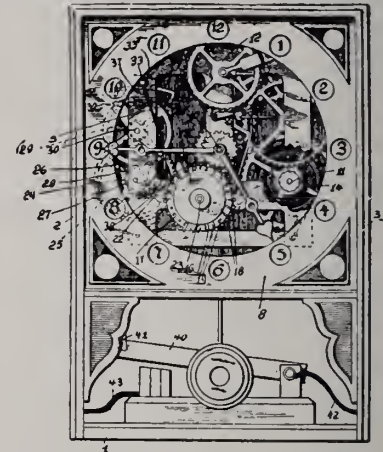

adjustment independent of one another with relation to said dial; an electric switch including a pivoted switch arm; switch operating means comprising a shaft having a crank at one end, means for rotating said shaft, a link connecting said shaft with said switch arm to move the latter from the former and a wheel on said shaft formed with diametrically opposite projecting arms, and an escapement mechanism for said switch operating means comprising a spring held rock shaft, an escapement body on said shaft having oppositely projecting arms each formed at their ends with angular portions on corresponding sides thereof to impinge said lugs as stops during the rotation of said wheel, and an arm, rigidly secured to the end of said rock shaft and projecting angularly therefrom, said arm terminating in an angular finger projecting into the path of the fingers of said plates to be engaged thereby during the rotation of said plates.

DESIGNS.

39,207. BAG. FRANK L. KIRK, New York, assignor to the Gorham Co., New York. Filed



Feb. 27, 1908. Serial No. 418,156. Term of patent 7 years.

BRITISH PATENTS.

(ABRIDGMENTS OF SPECIFICATIONS, 1906. FROM *The Illustrated Official Journal.*)

ISSUE OF APRIL 8, 1908.

28,504. CIGARETTE, ETC., CASES. L. SAGET, Hornsey, London, Dec. 13.

A cigarette or like case is made in two parts *a*, *b*, Figs. 2 and 4, hinged together and opened by a spring, both parts being covered by a slanting lid *d* also opening by spring action. A catch on the

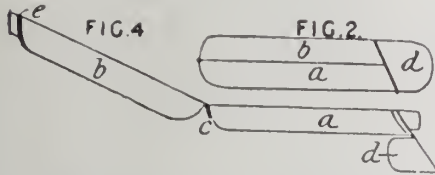

lid engages with a groove *e* on the part *b*, and is released by pressure on that part. Metal cross-strips near the hinge *c* ensure that the cigarettes shall protrude, as shown. Specifications No. 26,253, A.D. 1897, and No. 10,085, A.D. 1899, are referred to.

28,708. FOUNTAIN-PENS. E. DE LA RUE, London, Dec. 15.

To prevent leakage along the rod of the filling piston, an air chamber *c*, Fig. 1, with a venting opening *g* is formed behind the main packing *c*, a

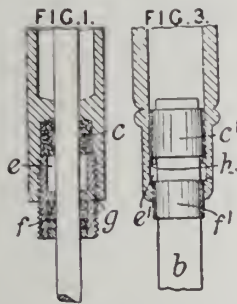

second packing *f* being provided. In an arrangement having a cork piston *c'*, the air chamber *e'* is formed behind a stop *h*, a second packing *f'* being applied to the rod *b*.

Complete specifications accepted March 25, 1908. 1907.

16,391. BINOCULAR TELESCOPE. STRAUBEL.

17,477. PURSE. HOULSTON.

19,240. BROOCH. MAYO.

20,001. TIME-RECORDER. BRYCE. 1908.

3,870. EYEGLASS-MOUNTING. LOUDEN.

Applications filed March 16 to March 21, 1908.

5,884. CANDLESTICK. H. G. PAIGE, Harrismith, Orange River Colony.

5,886. EYEGLASSES. JOHN STEVENSON, Birmingham.

5,913. ORNAMENTAL SAFETY-PIN. JOHN BAKER, Birmingham.

5,942. BRACELET. SIGMUND ZYTO, London.

5,970. TIME-SIGNALING APPARATUS. THOMAS ELDRIDGE, London.

6,005. HAT-PIN. FRANK HARRIS and A. J. HARPER, Birmingham.

6,167. UMBRELLA. FRANCOIS HAUTEVILLE, London. Complete specification.

6,186. UMBRELLA-HANDLE STRENGTHENER. DANIEL ROBBINS and PERCIVAL MACREADY, Birmingham.

6,217. UMBRELLA. DIANA MAGNIAC, London.

6,235. CLOCK-BELLS. S. P. BOUVERIE and FRANK HOPE-JONES, London.

6,269. COMB. J. L. COMBIS, London. Complete specification.

6,286. TIME-RECORDER. F. G. LAKE, Manchester.

6,349. WATCH BRACELET. SIEGFRIED SIMON, London.

Complete specifications accepted April 1, 1908. 1907.

6,060. CUTLERY. VICKERS.

7,563. ELECTRO-DEPOSITION OF METALS ON HOLLOW ARTICLES. FRIEDHEIM.

13,353. COMB. TREBITZKY.

18,180. ELECTROPLATING METALS. SCHMIDT.

21,190. CLOCKS. BUHLER. 1908.

3,074. INKSTAND. STUTFIELD.

Applications filed March 23 to March 28, 1908.

6,472. JEWELER'S GAGE. C. J. DAUNER and C. A. WERMANN, London. Complete specification.

6,500. NECKTIE CLIP. E. J. TRUSTRAM, London.

6,517. HAT OR HAIR-PINS. E. C. PANNETT and W. P. NEDEN, London.

6,525. CIGAR AND CIGARETTE CASES. PERCY HASLER, London.

6,562. ELECTRIC CLOCK WINDING MECHANISM. THE BRITISH THOMSON-HOUSTON Co., LTD., London.

6,633. MATCH HOLDER. R. N. HARGREAVES, London.

6,709. BRACELET FASTENING. J. G. HARLEHURST, Birmingham. Complete specification.

6,734. NAPKIN RING. W. B. CHALMERS, London. Complete specification.

6,796. MATCH STAND. H. G. ATKINSON, Birmingham.

6,875. CIGARETTE AND MATCH BOXES. J. D. STONE, Birmingham.

6,889. MATCH BOX. SIDNEY WIGGLESWORTH, Manchester. Complete specification.

6,948. CUFF-HOLDER. OSWIN FLECK, London.

6,946. CLASP. JOSEPH JACOMIN, London.

UNITED STATES TRADE-MARKS.

[The following trade-marks have been adjudged entitled to registration under the Act of Feb. 20, 1903, and are published in compliance with Section 6 of said act. Said section provides:

"Any person who believes he would be damaged by the registration of a mark may oppose the same by filing notice of opposition, stating the grounds therefor, in the Patent Office, within 30 days after the publication of the mark sought to be registered, which said notice of opposition shall be verified by the person filing the same before one of the officers mentioned in Section 2 of this act. If no notice of opposition is filed within said time the commissioner shall issue a certificate of registration therefor, as hereinafter provided for."

Marks which are stated to have been "Used 10 years are registrable under the last proviso of Section 5 of said act, which is as follows:

"And provided further, that nothing therein shall prevent the registration of any mark used by the applicant or his predecessor, or by those from whom title to the mark is derived, in commerce with foreign nations or among the several States, or with Indian tribes, which was in actual and exclusive use as a trade-mark of the applicant or his predecessor from whom he derived title for 10 years next preceding the passage of this act."]

PUBLISHED APRIL 21 1908.

Ser. No. **30,613.** (CLASS 37. PAPER AND STATIONERY.) L. E. WATERMAN Co., New York. Filed Oct. 15, 1907.



Particular description of goods.—Fountain-pens and pencils.

Ser. No. **31,323.** (CLASS 27. HOROLOGICAL INSTRUMENTS.) LANGENDORF WATCH Co., Langendorf, Switzerland. Filed Nov. 23, 1907.

REMINDER

Particular description of goods.—Watches, watch cases and watch movements.

Ser. No. **33,013.** (CLASS 28. JEWELRY AND

PRECIOUS-METAL WARE.) SCHANBACHER & BROD, Newark, N. J. Filed Feb. 26, 1908.



Particular description of goods.—Rings, lockets, scarf-pins, cuff-buttons, gold fobs, brooches, pendants, bracelets, bangles, festoons, tie-clasps, tortoiseshell combs with gold decorations, lorgnette-chains, studs, earrings, charms.

TRADE-MARKS REGISTERED APRIL 21, 1908.

68,607. WATCHES, WATCH CASES AND WATCH MOVEMENTS. CIE DES MONTRES INVAR, Chaux de Fonds, Switzerland. Filed Sept. 23, 1907. Serial No. 30,165. Published Feb. 18, 1908.

UNITED STATES PATENTS THAT HAVE EXPIRED.

[Reported especially for THE JEWELERS' CIRCULAR-WEEKLY by R. W. Bishop, Patent Attorney, Washington, D. C.]

Issued April 21, 1891.

450,617. TIME-RECORDER. J. C. ENGLISH, New York, assignor of one-half to R. L. Burnett, Plainfield, N. J.

450,618. METHOD OF PREPARING GEM-SETTINGS. ARTHUR HOGG, Buffalo, N. Y.

450,637. WATCH CASE. J. E. SEARING, Mount Vernon, N. Y.

450,638. WATCH CASE SPRING. J. E. SEARING, Mount Vernon, N. Y.

450,644. MACHINE FOR HOLLOWING PRECIOUS STONES. HANS SULZER, Winterthur, and ALBERT SCHMIDT, Glattfelden, assignors to H. Sulzer & Co., Winterthur, Switzerland.

450,699. NECKTIE-RETAINER. A. T. TOMPKINS, New York.

450,842. WATCH-PROTECTOR. ALBERT EPPLE, Providence, R. I.

450,884. CANDLE-HOLDER. GUSTAV GURTNER, Offenbach-on-the-Main, Germany.

450,932. TEA OR COFFEE POT. W. G. GIBSON, St. Stephens, Canada.

450,949. POCKET-LAMP. A. D. COSTI, Chicago.

450,966. ELECTRO-MAGNETIC APPARATUS FOR OPERATING STOP-WATCHES. F. A. MATTHEWS, Providence, R. I.

451,005. PENHOLDER. P. D. HORTON, Oakland, Cal., assignor of one-third to J. M. Walling, Nevada City, Cal.

Designs issued April 17, 1894, for 14 years.

23,194 and **23,195.** SPOONS. H. H. CABOT, Bristol, assignor to the Kent & Stanley Co., Providence, R. I.

Designs issued April 23, 1901, for 7 years.

34,395. RING. W. F. JUERGENS, Chicago.

34,396 and **34,397.** SPRING-SUPPORTS FOR HAT-PIN ORNAMENTS. A. A. McRAE, Attleboro, Mass., assignor to McRae & Keeler, same place.

34,399. SPOON. TYLER CALHOUN, Ridgeway, Tenn.

Design issued Oct. 18, 1904 for 3½ years.

37,188. GLASS DISH. J. E. MILLER, Washington, Pa., assignor to Duncan & Miller Glass Co., same place.

Capt. W. W. Fox, Lewistown, Ill., the oldest jeweler in Fulton County, has sold his establishment on Main St. and will retire from business, now being 72 years of age and suffering from the effects of services in the Civil War. He entered business here in 1860 and has been at it continuously ever since, excepting for a short period when he enlisted and served well in the defense of his country. His successor is George M. Blakeslee, who has been in the store for 15 years.

There is **ALWAYS** something **NEW** and **SWARTCHILD ALWAYS** has it
NEW POISING TOOL, WITH LEVEL

By means of the spirit level and adjusting screws this tool can be readily placed in a **perfectly level position**, permitting the most accurate work, which is so necessary.

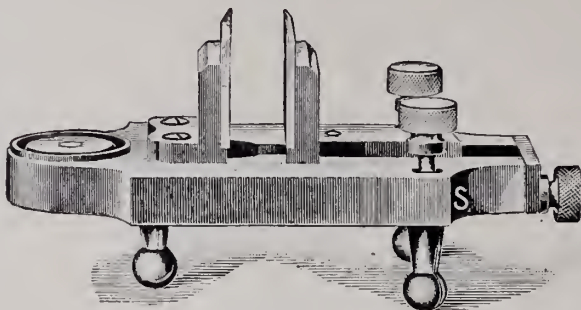

No. D 70, in wood case
 each, \$5.00

If you have not a copy of our double-sized, 440-page Catalogue, write at once. Sent gratis on application.

SWARTCHILD & COMPANY
 HEYWORTH BUILDING, CHICAGO

The Largest Exclusive Jewelers' Supply House in the World

WM. C. PENFOLD CO.

No. 35 MAIDEN LANE, NEW YORK

LARGEST EXCLUSIVE WATCH JOBBERS IN NEW YORK OF

Dueber-Hampden Watches
Dueber Cases — Hampden Movements

A Complete Line Always on Hand. Mail Us Your Orders

AN EXAMPLE OF A GREAT ACHIEVEMENT IN THE MANUFACTURE OF IMPORTED WATCHES IS EVIDENCED IN

"Tavannes" Movements and "Cyma" Watches

WHY?

Because all features heretofore existing that have been an obstacle to the modern watchmaker have been eliminated — being brought about by the introduction of automatic machinery in the manufacture of these goods, and the concentration of our mammoth factory on a modern scale, enabling us to furnish "FINISHED MATERIAL" ready to use.

"TAVANNES" movements and "CYMA" watches give most satisfactory results when exposed to the extreme influence of TEMPERATURE, ELECTRICITY or MAGNETISM.



TAVANNES WATCH COMPANY

131 Wabash Avenue
 Chicago

ADOLPHE SCHWOB, Sole Agent for the U. S.
 2 and 4 MAIDEN LANE, NEW YORK

704 Market Street
 San Francisco

TRADE-MARK INFORMATION WANTED.

The following marks have been forwarded to THE CIRCULAR-WEEKLY for identification, but so far, searches of our records and inquiries among manufacturers have failed to disclose the owners or users thereof. The publishers will be greatly obliged to any subscriber who can forward any information whatsoever as to the marks that will lead to the discovery of the manufacturer who has used or is using any of them.

NEW YORK.

On Filled Watch Cases.

T. F.

On Sterling Silver.

ACME.

On Filled Watch Cases.

MONARCH SILVER CO.

On Plated Ware.

CLOVEDALE.

On Imported Watches.

I. & CO.

On Bracelets.

P. 1/10

On Fobs.

EMPIRE W. C. CO.

On Watch Cases.

CRUSADE.

On Watch Cases.

LENOX SILVER PLATE CO.

On Plated Ware.

S.-N.

On Gold Jewelry.

M. V. & CO.

On Gold Watch Cases.

H. H. C. CO.

On German Silver Bags.

S. P. C.

On Jewelry.

E. H. & CO.

On Bracelets.

ENGINEER'S SPECIAL.

REPUBLIC, U. S. A.

CENTURY, U. S. A.

EDGEMERE, CHICAGO.

On Watch Movements.

G. N. S. & CO.

On Combs.

⊕ A ⊕

On Gold Rings.

K ⊕

On Brooches.

O. R.

On Lorgnette Chains.

BOSTONIA.

On German Silver Purses.

R 14K.

On Gold Jewelry.

L. M. & CO.

On Bracelets.

S. W. C. CO.

Used on Chains.



Used on Gold Rings.

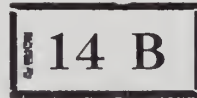

Used on Filled Rings.



Used on Watch Cases.



Used on Nickel Silver Flat Ware.



Used on Filled Watch Cases.

S. W. C. CO.

Used on Chains.

D. G. S. F.

Used on Watch Mainsprings.



Used on Stone Ware Teacups.



Used on Gold Chains.

UNIVERSAL.

Used on Mainsprings.



Used on Buttons.

Used on Jewelry.



Used on Gold Ware.



Used on Sterling Novelties.

R. S. & CO.

Used on Plated Hand Mirror.

H. C.

Used on Watch Fobs.

S. W. B. & CO.

Used on Class Pins.



Used on Gold Jewelry.



Used on Plated Flat Ware.

P — P

Used on Collar Buttons.

E. H. S. CO.

Used on Collar Buttons.

Large Silverware Contract Placed by the Harriman Railroads and Steamship Lines.

WHAT is probably one of the largest silverware contracts ever given out has just been awarded to the Meriden Britannia Co. (International Silver Co., Successor), of Meriden, Conn. The contract covers all of the silverware that will be used by the various railroads and steamships, as well as hotels and restaurants, comprising the so-called "Harriman lines," as follows: Union Pacific Railroad Co., Oregon Short Line Railroad Co., Oregon Railroad & Navigation Co., Southern Pacific Co., Northwestern Pacific Railroad Co., Illinois Central Railroad Co., Southern Pacific Co.'s Atlantic Steamship lines, as well as probably the Pacific Mail Steamship Co.

In addition to the ware to be furnished for new equipment, there is also a great deal that will have to be supplied to take the place of that now in use, which must be gradually replaced to conform to standard designs. At the present time, the Harriman lines have 100 dining cars, 50 buffet cars, 50 private cars, as well as many restaurants, hotels and steamships; all using silverware, with many additions now in prospect.

Following out W. V. S. Thorne's plan as director of purchases, the Harriman lines have adopted a standard style or design in silverware which they will use throughout their system, and the arrangements as now made will run for a number of years.

This contract, which the Meriden Britannia Co. has been successful in securing in a competition, is without doubt one of the largest ever placed and is in the nature of a tribute to the wearing qualities of the successful bidders' product as conditions surrounding silverware in dining car, hotel or restaurant use are the most severe possible, and the demand was for the best goods made.

Pearl Fisheries of Venezuela Leased.

IN consideration of an annual payment of 25,000 bolivares, the Government of Venezuela has granted to Luis F. Hernandez, for a period of 16 months, the exclusive right to exploit, or sublet for exploitation, the pearl fisheries of the Margarita Island in the Gulf of Cariaco, and on the coast of Punta de Araya.

The exploitation shall be carried on by the dredging system, and shall be discontinued during the months of July, August and September.



Lifting Watch so Dial Faces the Wearer



Watch worn on chain as a pendant, pinned to garment as additional security

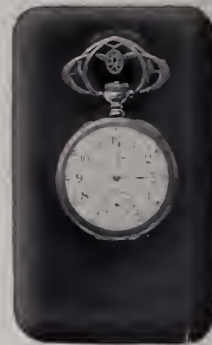

Showing Watch Worn with Dial Outward

Brooch and Case Combined

Which Enables a Watch to Keep Correct Time

CANNOT BE LOST WILL NOT PULL OR WEAR OFF

Dubois Safety Chatelaine Brooch Watch Case

Pateats Pending in U. S. and Foreign Countries

MERITS—Holds the watch firmly and securely, thus preventing the movement from being jarred, as there is no swinging or bobbing up and down while the wearer is walking or running. Protects both the case and garment from wear.

UTILITY—It can be raised so as to read the time, and reversed to have either the dial or back facing front, without removing brooch pin or watch from the garment. Can be worn on the shoulder, belt, chain or fob.

ARTISTIC AND PRACTICAL—The only brooch and watch combined. Affords absolute security, as it has a safety catch. Nothing to wear out, as it works on friction bearings. Eliminates the possibility of loss of the watch owing to either bow, hook, swivel or link wearing out, breaking or coming apart, as in the old style chatelaine. Does not interfere with either winding or setting of movement.

Licensed under Wachter Patent Ball-Bearing Bow

DUBOIS WATCH CASE CO.
21 and 23 Maiden Lane NEW YORK CITY

MADE FOR ALL SIZES OF LADIES' WATCHES
BOTH OPEN FACE AND HUNTING



Watch worn as Chatelaine, showing it lifted to read the time



Watch worn on belt as Chatelaine, also long neck chain can be worn attached to it



Showing Watch Turned with Back Outward



Watch especially adapted for outdoor sports, showing it worn as Chatelaine



Side View Showing Watch Turned in Swivel Brooch



A CATECHISM OF THE LEVER ESCAPEMENT
 Being an Informative and Instructive Series of Questions and Answers
 for Watchmakers and Apprentices.
 (Written expressly for THE JEWELERS' CIRCULAR-WEEKLY by T. J. WILKINSON.)

(Continued from issue of April 15.)

QUESTION:—Make a drawing of a pallet jewel, and mark its locking and impulse face respectively.

ANSWER:—The line A B (Fig. 48) is the pallet jewel's locking face, and the line B C is the pallet's impulse face.

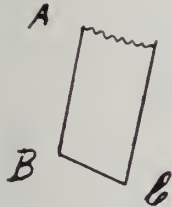

FIG. 48.

QUESTION:—Draw three lines supposedly illustrating respectively the slant of a receiving pallet stone, A, which lacked in draw, B, with excessive draw, and approximate the slant for correct draw.

ANSWER:—In Fig. 49 the drawing marked 1 indicates a want of draw, the figure marked 2 indicates too much draw, and the illustration marked 3 is approximately the correct pitch.

QUESTION:—When a tooth drops correctly

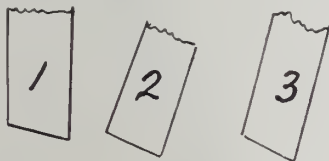

FIG. 49.

onto a pallet jewel, state the name of that part of pallet jewel upon which it drops.

ANSWER:—The pallet's locking face.

QUESTION:—When a tooth of the escape wheel leaves the locking face of a pallet, state upon what part of the pallet it next acts.

ANSWER:—The tooth enters onto the pallet's impulse face in the manner shown in Fig. 50; observe that the tooth acts on the pallet, not the pallet on the tooth.

QUESTION:—Make a drawing showing the manner in which a tooth passes off the pallet.

ANSWER:—The tooth leaves the pallet in

the manner indicated by Fig. 51; note the tooth acts on the pallet, not the pallet on the tooth.

QUESTION:—Is there any position of a tooth on a pallet's impulse face where these parts are in direct contact?

ANSWER:—Yes; as shown in Fig. 52.

QUESTION:—In Fig. 53 is illustrated an action of pallet and tooth that is irregular; it will be observed that the pallet is acting on the tooth, not the tooth on the pallet (which would be the correct action). What



FIG. 50.

is the effect of such a defective action on the escapement?

ANSWER:—It demoralizes the escapement action and therefore should be corrected or sent to the factory for correction.

QUESTION:—When an escapement "trips," upon what part of the pallet stone do you find the tooth of the escape wheel?

ANSWER:—We find the tooth on the impulse face of the pallet jewel.

QUESTION:—Is it correct for a tooth to drop onto the pallet's impulse face?

ANSWER:—No; the tooth should drop onto the pallet's locking face.

QUESTION:—If a tooth dropped onto the impulse face of the pallet, explain its effect on the guard pin, roller table action.

ANSWER:—It would cause the guard pin to be thrown against the edge of the roller table.

QUESTION:—If the drop lock was too deep on both pallets, how would you correct it? Also state what points after correction require attention.

ANSWER:—The jewels should be pushed back into their setting, thus decreasing the lock; the points that then demand attention would be a readjustment of the banking pins and a test for tripping to be made on both pallet stones and an examination of

inside and outside drop; also the shakes, inside and outside, should be examined.

QUESTION:—How do you reset pallet stones, A, with a deep lock, or, B, with the lightest, safest lock that particular escapement will allow of?

ANSWER:—Pallet stones should always be set with the lightest lock that particular escapement will allow of.

QUESTION:—Give the readiest method of resetting both pallet jewels, supposing all



FIG. 51.

guide as to their probable position has been lost.

ANSWER:—The best method is to straighten the guard pin, then close in the bankings so the guard pin barely touches the edge of the roller table; then, taking the bankings as a guide, set each pallet stone, giving it the lightest, safest drop lock the position of the banking pins will allow.

QUESTION:—Will this method work out correctly in all cases?



FIG. 52.

ANSWER:—No; because some escapements are badly constructed.

QUESTION:—What lines should we then follow?

ANSWER:—We have then to depend on our general escapement knowledge and make alterations that will tend to improve its defects.

QUESTION:—Explain what is meant by the drop of the escape wheel.

ANSWER:—That free flight of the escape wheel which we observe the moment a tooth is discharged from one pallet until its flight is intercepted by the opposite pallet.

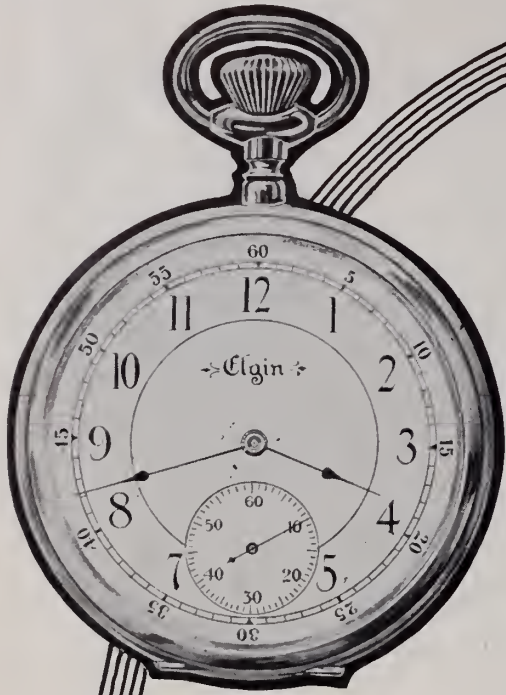

18
16
12



These are the mystic numbers that have made such a heavy increase in the demand for

The G. M. Wheeler Grade **ELGIN WATCH**

Made for years only in the 18 size—it became so popular with people wanting an accurate timekeeper at a moderate price that we were actually *forced* to make it also in thin models—16 and 12 sizes. Result—a tripled business!

DON'T be satisfied with a third of your share—carry the three numbers and reap the full advantage of the Elgin advertising.

See jobbers' list for prices
 or write the Company.

*Send for Elgin art booklets,
 "Timemakers and Timekeepers" and "The Watch."*

ELGIN NATIONAL WATCH COMPANY,

Factories: Elgin, Ill., U. S. A.
 General Offices: 131 Wabash Ave., Chicago.
 New York Office: 11 John St.

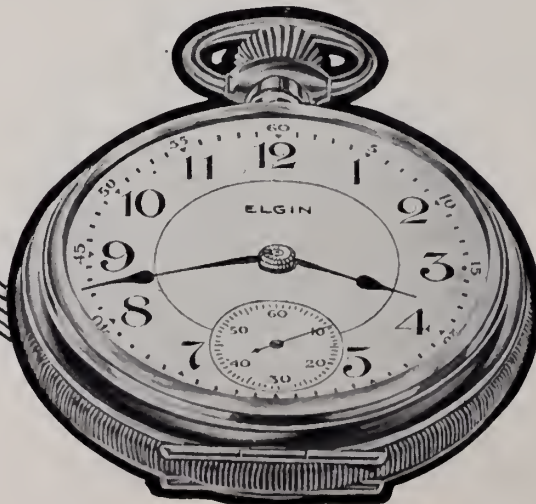

QUESTION:—What is meant by the terms “inside” and “outside” drop?

ANSWER:—When a tooth of the escape wheel is discharged from the discharging corner of the receiving pallet we observe a free motion or flight of the wheel, which exists until another tooth drops on the



FIG. 53.

locking face of the exit pallet. What we have just observed is called the inside drop. Again, when a tooth is discharged from the discharging corner of the exit pallet we note a free flight of the wheel, which continues until another tooth locks on the entering pallet. This free flight of the wheel is termed the outside drop.



FIG. 54.

QUESTION:—Should inside drop equal in amount the outside drop?

ANSWER:—Both drops should be of the same amount.

QUESTION:—How would you estimate or determine the drops?

ANSWER:—Always by observing the free flight of the escape wheel; the space (Fig. 54) between the back of the receiving pallet A and the tooth B shows the extent of inside drop; the space we observe (after a tooth drops) between the back of the exit



FIG. 55.

pallet and the tooth behind it represents the outside drop (Fig. 56).

QUESTION:—If inside drop was too little as compared with outside drop, how would you correct it, and what points would then require attention?

ANSWER:—When the inside drop is less than the outside drop, the pallet jewels will have to be spread apart enough to equalize the drops. We would have also to look out for the draw on the pallets. It is usually best to alter but one stone, selecting for the purpose that with the most defective draw. Another point which would also call for attention is the shake of the pallets with the escape wheel teeth.

QUESTION:—What is meant by the terms

“inside” and “outside” shake of teeth of escape wheel with the pallet stones?

ANSWER:—By shake is meant that position of the pallets in conjunction with the teeth of the escape wheel; to express that position of these parts where least freedom is found to exist, to determine and observe inside shake, bring the tooth resting on the locking face of the exit pallet down to the lowest locking corner of that pallet (Fig. 55); hold it there and observe the space which exists between the back of the receiving pallet and the tooth directly behind it. We now have the parts in that position where least inside freedom exists between them. To estimate the outside shake, bring the tooth resting on the locking corner of the entrance pallet down to its lowest locking corner, then observe the space (Fig. 56) which exists between the back of the discharging pallet and the tooth immediately outside this pallet. The parts are now in that relation to each other where least outside freedom exists.

QUESTION:—Is it essential that both shakes should be present?

ANSWER:—Yes; any tightness of the pallets with the teeth of the escape wheel will cause the watch to stop.

QUESTION:—Can inside shake exist without outside shake, or would it be possible to find the shakes unequal?

ANSWER:—Yes; inside shake might be a surplus quantity, in which case the outside shake, *i.e.*, the relation of the escape wheel teeth with the pallets, as before described, would be deficient. All irregularities in the shakes should be corrected.

QUESTION:—Should the shakes be equal?

ANSWER:—The shakes, like the drops, should be equal.

QUESTION:—If an escapement lacked inside shake, how could it be remedied, and what other points would then require attention?

ANSWER:—When the inside shake is a deficient quantity the pallet stones would have to be spread apart, and, as in an escapement which lacked inside drop, the draw on each pallet would require attention. Usually the defect can best be corrected by altering that stone which has the most defective draw, provided the lockings are correct.

QUESTION:—After every alteration of a pallet jewel to correct defective drop, or shake, what further examination should be made?

ANSWER:—Attend to the locks and examine for tripping errors.

QUESTION:—Is there any difference in the amount, say, of inside shake as compared with inside drop?

ANSWER:—Yes; the drop is always greater than its corresponding shake.

QUESTION:—In which type of escapement do we find the least drop, *viz.*, the club or the ratchet tooth?

ANSWER:—Least drop is found in escapements employing club-toothed wheels.

QUESTION:—Is drop a waste of energy?

ANSWER:—Yes; the less drop employed, the better.

QUESTION:—What are the uses of the banking pins?

ANSWER:—Principally to control the extent of lock of tooth on pallet jewel. We can, by their means, increase or decrease

the amount of lock and incidentally regulate the space separating the guard pin from the edge of the roller table; their position also affects the entry of the roller jewel into the notch of the lever.

QUESTION:—What may we consider the primary position of a banking pin?

ANSWER:—That position to which it is adjusted so that the drop or first lock only



FIG. 56.

exists as shown at P for the lever and D for the pallet, in Fig. 57.

QUESTION:—With the banking pin in its primary position, what is the relation of the guard pin to the edge of the roller table?

ANSWER:—It is close to the edge of the roller table.



FIG. 57.

QUESTION:—Is the guard pin ever closer to the edge of the roller table?

ANSWER:—Yes; just at the moment it emerges out of the crescent.

QUESTION:—When the banking pin is in its secondary position, *i.e.*, adjusted so it allows draw lock to take place, state its effect on the escapement action.

ANSWER:—Opening a banking pin to its secondary position allows an increase of the lock to take place; this increase or second lock we have termed draw lock, as shown at T, Fig. 57, and in connection with the increase of lock is the motion of the lever to S; this motion of the lever incidentally increases the space separating the guard pin from the edge of the roller table.

QUESTION:—How should the banking pins be set as regards the lever run? After drop lock takes effect, should we then observe an equal run of the lever to each banking pin?

ANSWER:—Yes; the run of the lever toward each banking should be equal. This would also indicate that the locks on the pallet stones were equal in amount.

QUESTION:—How do you set the bankings (A) so as to allow for drop lock only, or (B) so as to allow for second or draw lock?

ANSWER:—When an escapement is in correct running condition the bankings are set to allow of the second lock.

QUESTION:—Supposing the banking pins were bent apart, explain the effect as it re-

Keystone Solid Gold Watch Cases



“A”



“THE VOGUE”



“C”

- ☐ Flush Joint—made in 12 size Queen only.
- ☐ Illustration “A”—Fair Weight. Antique Pendant, French Bow, Plain Polish only.
- ☐ Illustration “C”—Heavy Weight. Elliptical Pendant, French Bow, Plain Polish, Satin Finish, Roman.
- ☐ This Model is the Thinnest and Most Compact Case made for Standard 12 size American Movements.
- ☐ A Case that will give good satisfaction, meeting the requirements of a popular priced watch.
- ☐ Write your jobber for Samples and Prices.

KEYSTONE 14 K. SOLID GOLD CASES ASSAY

Trade-Mark



in back.

585-THOUSANDTHS FINE

14 K. GOLD ASSAYS 583 $\frac{1}{4}$ -THOUSANDTHS FINE

Note this guarantee



Look for



this tag.

THE KEYSTONE WATCH CASE CO.

NEW YORK

CHICAGO

PHILADELPHIA

CINCINNATI

SAN FRANCISCO

lates to the guard pin's relation to the roller table, (A) dial up, (B) dial down.

ANSWER:—If, when the dial was up, we found just about the correct shake to exist between the guard pin and the roller table, we would discover, when the watch was placed dial down, a dangerous decrease in the freedom which should normally exist between the guard pin and edge of the roller table, which might cause stoppage.

QUESTION:—In a double-roller escapement, when the roller jewel is just out of the notch, in what position relative to the roller table would you find the guard finger?

ANSWER:—The guard finger would still be in the crescent.

QUESTION:—What is the necessity for the long lever horns on the lever of a double-roller escapement?

ANSWER:—To prevent the escapement tripping while the guard finger is within the crescent.

QUESTION:—In a double-roller escapement when the guard finger is just about to leave the crescent, would the roller jewel be past the lever horn?

ANSWER:—No; it would be found about opposite the end of the horn.

QUESTION:—If in a double-roller type of escapement it was discovered that just as the guard pin was about to leave the crescent the roller jewel was beyond the tip of the lever horn, what error would be discovered?

ANSWER:—The escapement would trip, because the horn of the lever would be too short.

QUESTION:—Why is it essential that the end shakes of the pallet and balance staff in double-roller escapements should be of the same amount?

ANSWER:—The end shakes of each should be equal to avoid irregular actions of the parts; for instance, should the end shake of the pallet staff be the most, there is danger of the guard finger striking the end of the roller jewel.

(To be continued.)

Remarkable Clock, Showing Movements of Earth, Sun and Moon.

THE horological installation, in the establishment of M. Dufayel, Paris, includes an astronomical clock, of which we present an illustration, known as a chronologometer—a movement placed on the façade, where it operates the dials, and a belfry of bells, placed on the cupola outside.

The Chronologometer.—This clock, formerly located in the "Café Parisien" and reinstalled, after complete overhauling and repair by Chateau Père et Fils, in M. Dufayel's establishment, includes a weight movement, operated by a friction roller chain and rewinding itself every seven hours. It operates a series of systems representing the true movements of the earth, of the sun and the moon and a large calendar dial, operated by a hand having an index that follows a spiral and shows the dates for a series of days amounting to several centuries.

This dial and the one showing astronomical epochs is engraved with more than 100,000 letters. The entire clock is contained in a glass cabinet, presenting, at its upper

part, four gilded dials giving the current time. It is equipped with a mechanism for transmitting the time and regulating the clock located outside on the façade.

The façade clock is operated by a weight that is electrically rewound by a dynamo, about every four hours. It has a compen-

set of chimes. The quarter hours are sounded by a tune played on 10 bells. The chime-work is special and can be operated by a keyboard. This system employs an axis provided with a fly, which can be turned by hand or by a dynamo, and which provides the power for vigorously pulling the

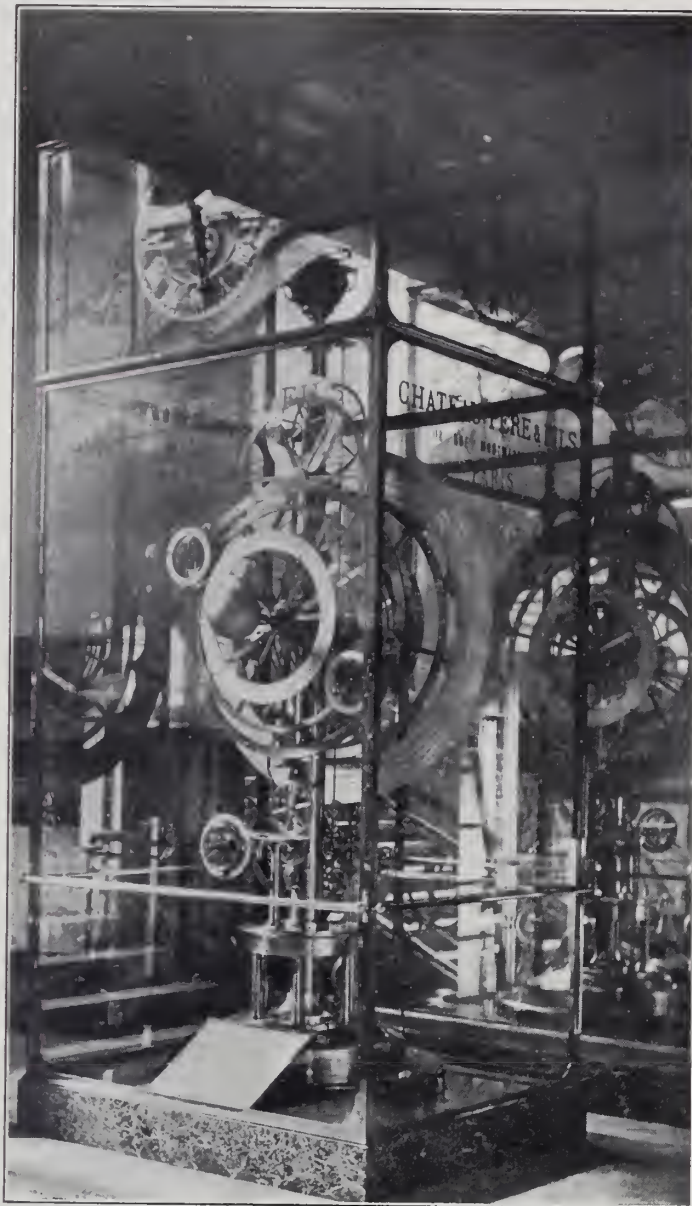

ASTRONOMICAL CLOCK OWNED BY DUFAYEL, PARIS.

sated pendulum, a remontoire and a releasing apparatus for operating, every quarter of an hour, the chimes in the belfry. It controls, by a gearing, a lunar dial and records every hour by means of a special patented apparatus on a barometrical dial, which coincides with an aneroid mounted on the clock. Finally it is fitted with a mechanism operating a dial with three hands, showing the date, day of the week, months and year. It gives the time to an hour dial, surrounded by medallions representing the constellations. At night the four transparent dials, which are double, are illuminated by electricity.

The bell-work consists of quarter chimes, released electrically by the façade clock every quarter of an hour and controlling a train which, at the desired hours, starts a

bell clappers. At each pressure of a key by the finger, when it is played by hand or by the pins on an automatic-drum attachment, when this is turned, a suitable stroke is given. The chimes may also be released from below by pressing a button.

All the weights operating these bell-works are rewound by electricity by means of a dynamo of unique design. The belfry is established in an iron frame with double batteries for the tunes each quarter of an hour and for the chimes.

H. E. Harris, a jeweler of Lowell, Mass., was robbed a short time ago of \$96, while boarding a train at the Middlesex St. station. The police have been notified, but thus far no clue has been obtained to the thief.



EXCELSIOR

A RELIABLE watch at a popular price.

Every jeweler must realize what this means to him—to have at hand a line of reliable low-priced watches put out by a factory organization that specializes in PERFECTING THIS ONE MOVEMENT.

Seven jewels, quick train, cut expansion balance, Breguet hair-spring, stem-wind and pendant-set (except 18-size, lever set), cased and timed at the factory, and supplied COMPLETE.

The new 12-size EXTRA THIN is the only really accurate thin watch at anything like the price—the most distinctive popular watch made.

Excelsior watch is price-protected—printed price ticket attached at the factory fixes the retail price everywhere and gives the jeweler his rightful profit on every sale.

Made in 6, 12, 16 and 18 sizes, in plain polished, engine turned and fancy engraved cases of three grades—gold-filled 20-year guarantee, retailing at \$9.00 open-face, \$11.00 hunting; gold-filled 10-year guarantee, \$6.50 open-face, \$7.00 hunting; Silverode (wears like silver), \$4.50 open-face, \$4.75 hunting.

Inquire of your jobber and write to the factory for literature.

NEW YORK STANDARD WATCH CO.
Jersey City, N. J.

YOU CAN GET A LINE OF

New England Watches

to sell as low as \$2.00 if you want them.

- ☞ They are *real* watches, too, and covered by the regular *New England* guarantee.
- ☞ Nickel-Silver Cases, made in two sizes. Five different designs in size 18, and four designs in the 8 size.
- ☞ These watches also offer an unusually large percentage of profit to the dealer.
- ☞ Write to-day for particulars.

The New England Watch Co.

Waterbury, Conn.

Chicago

San Francisco

THE LARK ALARM

*The New SOLID PALLET, Best of
STANDARD Alarm Clocks*

SELLS AT SIGHT

Special Advertising Matter Furnished to Jeweler
upon application

THE STANDARD JEWELER'S CLOCK

Write for Description and Prices

**THE NEW HAVEN CLOCK CO.
NEW HAVEN CONN.**

DON'T FORGET THE TATTOO

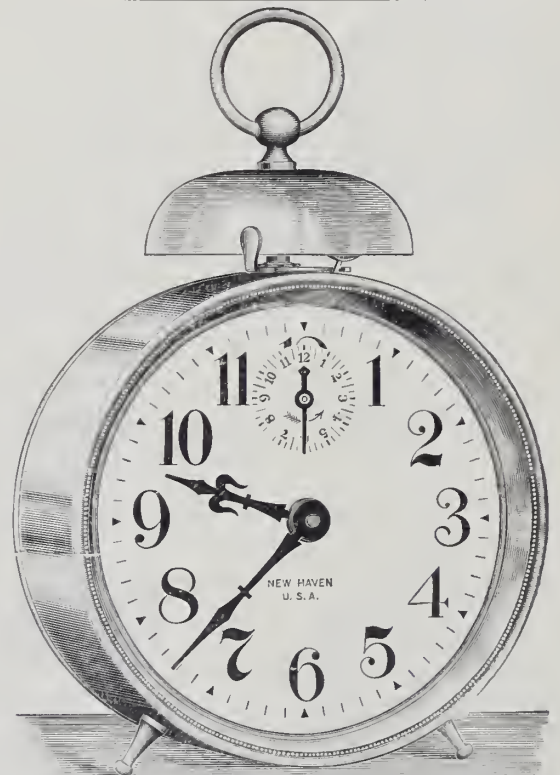

*4-Inch Arabic Dial
Case and Trimmings all Nickel Plated
and Highly Polished
Has Switch for Stopping Alarm*

SESSIONS CLOCKS

Superior Finish
Popular Prices

We have added a number of fine marqueterie cabinet clocks to our line which will interest you.

The Sessions Clock Company

FORESTVILLE, CONN., U. S. A.

New York Salesroom, 37 Maiden Lane

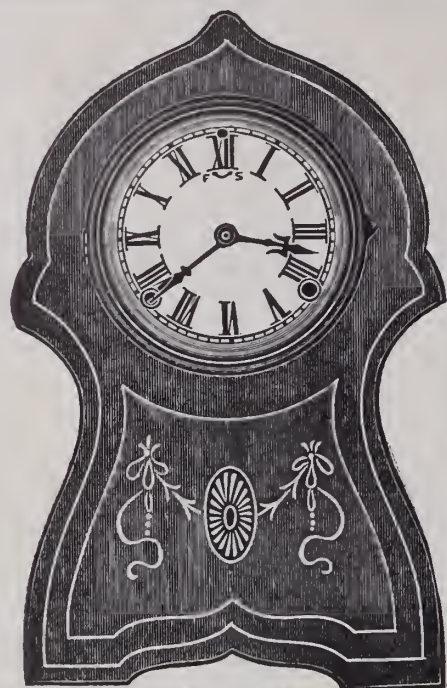

MANCHESTER

Height 13¾ in. Width 8¾ in.

GUN METAL



WATCHES

Positively the most interesting line of moderate priced Gun Metal, Nickel, Gilt, Enameled, Silver and Gold Watches. GUARANTEED THIN - MODEL WATCHES.

Does Your Stock Move?

Drop us a line. We will present to you a new proposition to increase your sales. We furnish you the whole outfit free of charge, delivered at your store.

American-Swiss Watch Co.
1 MAIDEN LANE, NEW YORK

The Lady Racine



Positively the BEST chatelaine watch in the market.

Machine Made

10, 11, 12 and 13 Line; Cylinders and Levers; cased in Nickel, Gun Metal, Silver and Gold.

Material on Hand.

Write for prices.

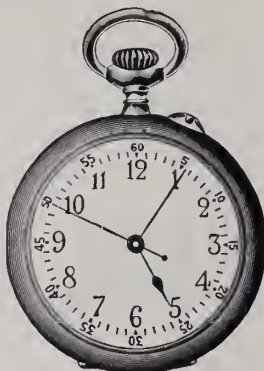

Lady Racine Nurse Watch.

JULES RACINE & CO.,

103 STATE ST., CHICAGO.

SOLE AGENTS

37 MAIDEN LANE NEW YORK.

For Sale by all Jobbers

HALL CLOCKS



Elliott's Celebrated Tubular Chimes

HARRIS & HARRINGTON,

12 BARCLAY ST., NEW YORK

Sole Agents to the Trade for
J. J. ELLIOTT & CO.
LONDON.

A.W.C.CO

The Perfect Case

Perfection is made up of trifles, but perfection is no trifle. It is the many details, each in itself trifling, which distinguish the perfection of the **A.W.C.CO** CASES.

We illustrate an English case, made in all sizes, open face and Hunting, and 14K. and 18K.

Sold by us directly to you

American Watch Case Co.

9-11-13 Maiden Lane

New York



C 385

ENGLISH CARVED

THE Ægis Case

(PATENTED)

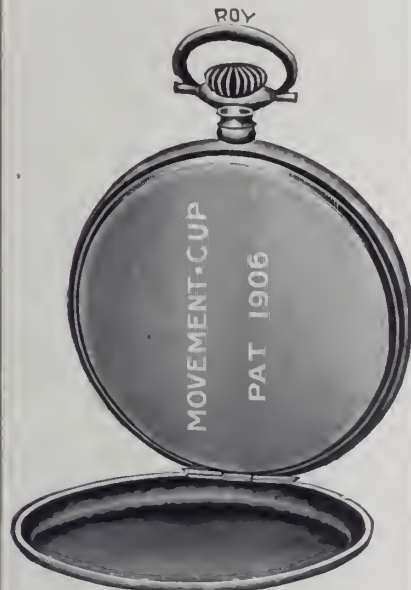

THE ÆGIS is a new creation in gold case making. The center and bezel are in one. Instead of having the ordinary Cap, this case is provided with a rigid metal movement Cup, held friction tight in position. This Cup gives protection to the movement such as cannot be secured with the conventional jointed cap, while dust is thoroughly excluded from the front by means of the one-piece center and bezel.

MADE ONLY BY

ROY WATCH CASE CO.

21-23 MAIDEN LANE
NEW YORK

San Francisco Office, 704 Market Street

Learn Watchmaking

Refined, profitable labor. Competent men always in demand. We teach it thoroughly in as many months as it formerly took years. Does away with tedious apprenticeship. Money earned while studying. Positions secured. Easy terms. Send for catalogue. Address

St. Louis Watchmaking School, St. Louis, Mo.

WATCH REPAIRING FOR THE TRADE

Careful, Reliable, Prompt Work. Trade References. Price List on Request.

A. D. PAPAZIEN

71-73 Nassau St., Cockroft Bldg. NEW YORK

Ball Watches

THE RAILROAD STANDARD

The Watch Inspector's Friend

WRITE TO-DAY FOR OUR DEALER'S PROPOSITION

Minneapolis, March 12, 1908.

Gentlemen:
Your 18 size "Official" No. 548110 arrived just in time to aid me with my watch inspection work, as my electric clock was out of commission for 23 days, during which time your watch varied only 4 seconds. Very respectfully,

L. L. WILLIAMSON.

Railway Watch Inspector
1717 E. Franklin Ave.

The Webb C. Ball Watch Co.

Ball Building
Cleveland

Railway Exchange
Chicago

Pacific Type Fast Express Engine for
New York - Boston Service.



THE progressive jeweler to-day knows that when a customer comes into his store he must be impressed with the idea that he is doing a high-class business.

In order to do this he must have the goods. No article you can buy will give your store more tone than a fine Hall Clock. It will also give you a fine profit. Purchase a "Waltham" and you will soon find a customer for it.

Send for catalogue, descriptive of many styles and kinds.

WALTHAM CLOCK COMPANY

Office and Salesrooms, Waltham, Mass.

JULES JÜRGENSEN

Watches and Chronometers

PARIS—"THE GRAND PRIX"—1900

SOLE

RUDOLPH & SNEDEKER
65 Nassau St., New York

AGENTS



STORE KEEPING DEPARTMENT

That this department shall prove mutually beneficial to our readers, it is desirable that the members of the trade generally communicate with **THE JEWELERS' CIRCULAR-WEEKLY** regarding any advantageous device or plan which they are utilizing in connection with their business.

A Window Display Consisting of a Diamond Cross and Crown Worth \$200,000.

THE show windows of the large Chicago jewelry establishment of C. D. Peacock have always been noted for their lavish

the diamond cross and crown exhibited in the south show window on the State St. side of the concern's attractive establishment.

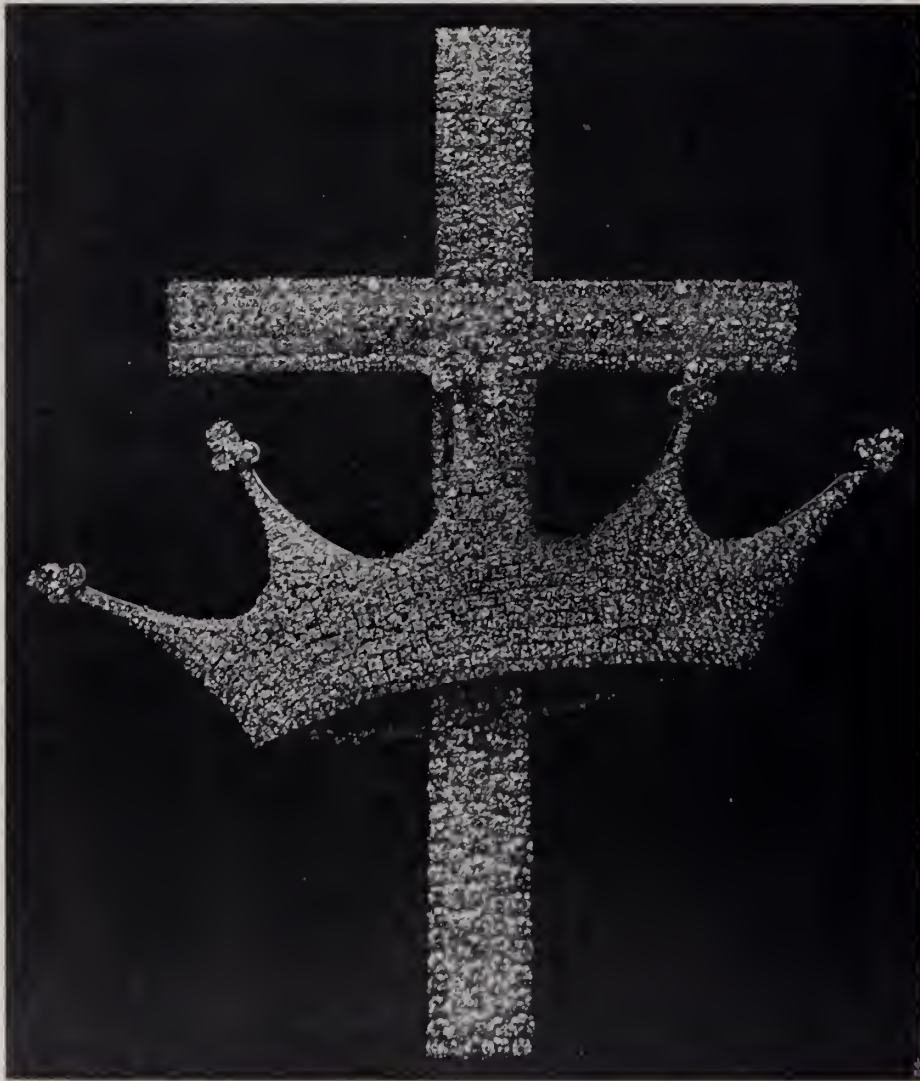

A DIAMOND CROSS AND CROWN DISPLAYED BY C. D. PEACOCK, CHICAGO.

exhibition of high class jewelry, yet 10 days before Easter every display heretofore indulged in paled into insignificance before

The cross and crown were of immense size and composed entirely of diamonds weighing altogether 595 carats, less 1/16 of

a carat. The diamonds varied in weight from a quarter carat to five carats. The cross proper contained 394 stones weighing $\frac{3}{8}$ and $\frac{5}{64}$ carats; the crown contained 200— $\frac{1}{2}$ less $\frac{1}{64}$ carats. The cross measured 14 inches in length by $8\frac{1}{2}$ inches in width.

The diamonds were mounted in German silver, the setting being $1\frac{1}{2}$ inches wide for the long part of the cross and $1\frac{1}{4}$ inches wide for the arms.

The crown measured from tip to tip just 12 inches and was seven inches across at the base, having a depth from the points down of four inches. The total number of diamonds set was 1,067.

This remarkable exhibit was suspended in the center of the show window and was cleverly lighted by concealed electric lights, which made the cross shine brilliantly by daylight. Purple velvet hangings tastefully draped around the cross and crown enhanced the beautiful effect. At the bottom of the show window on a white silk foundation only a few pieces of rich jewelry, displayed on purple pieces of silk, were shown.

The cross was on exhibition till the Saturday before Easter from 8.30 A. M. to 5.30 P. M., and at night a photograph of the cross was installed in its place. A placard announced its hours of exhibition, and even the photograph attracted large crowds at night.

Negative Advice.

DON'T wait for fortune to smile on you. Fortune doesn't smile all the time. When she does she usually favors those who hustle, and not those who wait.

Don't talk about your competitor.

Don't waste valuable moments on details that a subordinate can handle.

Don't walk a mile to save a nickel if you value your time more than pennies.

Don't shake hands with a man as if it hurt you.

Don't show yourself too anxious to get an order. The customer will see it in your manner, and he will make the bargain, not you.

If you have one or two customers who like to pay outrageous prices for goods, don't forget that you can better afford to lose all such customers you're likely to have than a tenth of the trade that wants to purchase just as cheap as possible.—*Printer's Ink.*

Storekeeping Department.

How to Meet the Competition of the Mail Order House.

(Continued from issue of March 25.)

RETAILERS who are on the watch for everything which will enable them to more successfully fight the mail order houses will do well to carefully check up their freight bills.

This may be considered a useless labor. But a little attention given to the matter will convince the most skeptical that there is good money to be made for the time spent in figuring over these bills and making out claims for over charges.

It is an easy matter to get from your agent and your jobbers the correct freight rates from the different points on each class of goods you handle. With this information at hand you can quickly check over the rates charged on your expense bill, to see that some clerk has not given the shipment too high a rate. The necessity for doing this will be apparent to you when you learn that a railroad clerk who makes an error which costs the railroad money always has to stand the loss himself. As you have no means of making him pay you for your losses, when there is an over charge, this makes it certain that when there is any doubt on the part of the clerk as to exactly what classification your goods should bear, you will be charged the highest rate. He does this as a matter of self-protection. Railroad classification sheets are rather complicated affairs, probably made that way intentionally, as it brings the railroads thousands of dollars more income each year from careless shippers. Railroad clerks are only human, and are as likely to make errors as other people.

After you have checked up the rates charged, and found them right or wrong, go ahead and check up the weights, to see that no error has been made in the weight of shipment. Then figure the weights by the rates and check up the totals.

All wholesale houses, all mail order houses, and, in fact, all progressive merchants, do this. Whether it pays them or not can best be judged by the fact that some of the large houses pay \$4,000 to \$5,000 per year for a traffic man, who gives his entire attention to seeing that his house pays no more than it should for freight. This man must make a greater saving than his salary, or he would not be retained.

A large part of the goods you handle cost you just the same as they cost the mail order houses, with the exception of the freight being added. That freight amounts to a considerable percentage in a good many cases, and you should certainly want to make this additional percentage of cost just as small as possible. Do not let the railroads help the mail order houses to get the best of you.

A large shipper recently told the writer that errors were found in over half the expense bills that they paid, and as every bill was figured over as soon as it reached the office, claims were at once made out to cover these errors, for they were always in favor of the railroad companies.

(To be continued.)

A Jeweler Whose Odd Hobby is the Taming of Tarantulas.



D. GOODIN.

A JEWELER of McKinney, Tex., D. Goodin, is reputed to be the first person who ever undertook the odd task of taming tarantulas. A group of Mr. Goodin's pets are shown in the accompanying photograph resting harmlessly on their master's hand.

Mr. Goodin has been engaged in the jewelry business since 1860, when he opened a store in Boone, Ia. Fifteen years later he moved to McKinney, Tex., and has been located there permanently ever since. Within the past year, however, he practically retired from active business, owing



A HANDFUL OF TARANTULAS, TAMED BY A JEWELER OF MCKINNEY, TEX.

to ill-health, a son, C. W. Goodin, having taken complete charge as manager.

The taming of tarantulas has been one of the hobbies of the elder Mr. Goodin since 1896.

The Way of the Enterprising.

AN attractive Easter display was made by the C. B. Brown Co., Omaha, Nebr.

A large white cross resting against a large purple square background formed the center back of the window, pedestals on each side supported candelabras, while below at the base were potted Easter lilies. Diamonds, precious stones, gold and silver jewelry were effectively displayed.

An interesting curio exhibited in the window in the store of Percy H. Greer's "Olde Curiosity Shop" on W. 2d St., Los Angeles, Cal., is a necklace on which 50 gold dollars hang as pendants. These dollars all bear the date of 1876 and were made in the Philadelphia Mint in that year. The necklace was a gift to the bride at a golden wedding, each dollar representing a year of married life.

"June Wedding Advertising" will be published in the issue of May 13.

An Interesting Business Card.

FEW business cards in the United States or any other country can match that of an old-established jewelry house in Newburyport, Mass. Handed down from father to son through generation after generation, its record is most remarkable.

On one side of this unique card is the following announcement of the firm's business, location and status:

Established
1760.
MOULTON & LUNT,
Watches, Silverware and Jewelry,
40 State Street,
Newburyport, Mass.

This stamps the concern as no ordinary one, but the antiquity of the Moulton element, which is still represented in the business in the person of the William Moulton of the present day, is still more impressive.

Here is a reproduction of the reverse side of the business card:

Established before 1692.
THE MOULTONS,
Gold and Silversmiths.
William Moulton, 1st, born in England, 1602;
Came to America, 1638.
William Moulton, 2d.....Born 1640
Joseph Moulton....." 1680
William Moulton....." 1710
Joseph Moulton....." 1740
William Moulton....." 1772
Joseph Moulton....." 1814
Edward Moulton....." 1846
William Moulton....." 1851

Don't allow your clerks to smoke while on duty.

Don't work all the time. Remember, even machinery needs rest.

Don't show many different kinds of goods at once.

Don't be satisfied with customers you have without attempting to get more. The successful man uses follow-up letters and other means to accomplish this purpose.

Don't worry about things that may happen. They may be opportunities, not trials, by the time they reach you.

Don't be satisfied until you bring everything to a complete finish.—Chicago Tribune.



RETAIL JEWELERS ADVERTISING

Letterheads—Odd, Quaint, Original and Impressive.
Up-to-date Stationery Used by Retail Jewelers.

IN response to many requests from subscribers we are pleased to publish another group of up-to-date letterheads. The

was printed in blue, green, yellow and a very light shade of photographic brown. Kingoro Ezawa, the well-known jeweler

the tree. George T. Brodnax, Inc., Memphis, Tenn., only recently prepared the new letterhead which is represented herewith. The original is very beautiful, and shows in the center a sharply defined half-tone illustration of the spacious establishment. It is printed in two colors.

The letterhead of James D. Bailey, Toronto, Ont., is printed in blue and red, and that of J. A. Oswald, Crawfordsville, Ind., in blue. The rest are black and white effects.

The original letterhead of the E. O. Zadek Jewelry Co., Mobile, Ala., has a particularly dainty appearance. The building is illustrated by means of a soft but very clear etching. Articles treating of the vogue in stationery and the advisability of using attractive letterheads and envelopes were published, with examples, in the issues



RETAIL JEWELERS' LETTERHEADS—SOME PRINTED IN COLORS AND OTHER PLAIN BLACK AND WHITE EFFECTS.

letterhead of the O. A. Hesla Co., Prescott, Ariz., is printed in blue, the lettering being embossed. R. S. & J. D. Patterson, Port Huron, Mich., make use of some very well-wrought line work. The letterhead of Hall & Sayles, Janesville, Wis., is blue, with raised lettering, and so is the letterhead of Porte & Markle, Ltd., Winnipeg, Can.

Ike S. Martin, Milwaukee, Wis., has a letterhead that is very suggestive of the jewelry and pawn brokerage business. It

of Tokio, Japan, with branch establishments in Osaka, Nagasaki, Otaro and Yokohama, prints his letterhead both in English and in Japanese. A very original style has been adopted by Stewart & Son, Huntingdon, Pa.

"The only apple on the tree," however, comes from W. H. Appel, of Allentown, Pa. The luscious fruit suggesting his name is printed in natural tempting tints. The initials are represented by an artistic manipulation of the branches and twigs of

of THE CIRCULAR-WEEKLY of Oct. 9. and July 31, 1907.

Progress is impossible to a discouraged advertiser, and discouragement is often brought on by trying to cross the bridge before it is reached. Try not to anticipate failure; wait for the accumulative results of your advertising, which may be slow, but are sure, if your proposition is good and is properly presented.—The Haberdasher.

Retail Advertising Department.

Newspaper Advertising.*

By E. H. LEFFERT, Council Bluffs, Ia.

IF advertising is the foundation of business success, so common sense is the foundation of advertising success. The same common sense that serves so well in the testing of any other business problem serves just as well when it comes to advertising. There is little of the catchpenny business about successful advertising—that is, for the average merchant. Advertising merchandise, even if the line be as restricted as that of the jeweler, is one thing. Advertising an article—a single article, such as a brand of flour, a make of clothes, an article of food, such as you have for breakfast—this is another thing.

It is in advertising an article that the catch line and other devices serve so well. They may not be used to the same extent or with the same success in presenting consistently and comprehensively from day to day a line of merchandise. Here you may use catch phrases—indeed, you ought to—but they are not sufficient or even of first importance.

You assign me to talk about newspaper advertising. I find myself thinking about jewelry advertising. Perhaps the rules and ideas adaptable to my line of business would not suit in some other, but in the absence of the test I am inclined to think that they would. The publicity problem is the same in a general way for all lines of business.

With us, keeping everlastingly at it seems to count. The results are not instantaneous. We seldom expect that. We may advertise something in particular quite heavily for several days and not have a single call for it. That might discourage some people. It doesn't discourage us. As the result of other and earlier advertising, people are coming to the store and buying other things and meanwhile we are keeping the name of the establishment ever before the public and ever associated with something new, some suggestion. And right here is a good point for the advertiser.

The best advertiser in the world is the newspaper man himself. I refer to his methods. What does he put into his paper in order to interest the public and hold public attention? News, news, all the time news! So why should not I or any other advertiser do likewise? Why should we not make our space in your papers interesting? We try to put news—jewelry and optical news—into every piece of advertising copy that goes out of our store. I spoke of the value of keeping the name of the establishment before the public. That is true, but to get results, the greatest results, the name should be constantly associated with suggestions, ideas, news. Thus, you see, we advertisers help you to make your newspaper interesting. We help you to make newspapers of them.

A newspaper without interesting advertisements wouldn't last long, assuming that circulation is necessary to success. It would not circulate. The advertisements of the

newspaper come closer home to the people than most of the other matter. Why? Because the main concern of nine-tenths of the people is living. Life is an unending round of buying, buying, buying—where to buy and what to buy. Look in the newspaper. Read the advertisements. People are so susceptible of suggestion. They like to be baited. Thus I say that the ad. should always be readable and interesting. It should be in good English, not stilted, but clear and written with reasonable grammatical accuracy. An untidy ad. is the messenger of an untidy business. Likewise the tidy ad. bespeaks a tidy business. People like order. They abhor disorder.

In the jewelry business we cater to luxury a great deal. You might say that watches and clocks are necessities, but in general and as distinguished from the merchandise of the clothier we deal in luxuries. We have to take this into account. In just what way we take it into account I may not be able to state clearly, but you may catch the point from the suggestion that none of you had to be reminded to eat your breakfast this morning. If your wife wanted you to bring home with you a dainty brooch for her or a ring for the baby, you had to be reminded of that, and probably were.

We keep reminding the people of the seasons, of the holidays, of the birthday, of the wedding, of Lent, of the christening, and you may be sure, all liberally besprinkled with reminders of the thousand and one useful and beautiful things to be had at our store as gifts for these occasions. Outside of watches and clocks and perhaps diamonds and tableware much of the jewelry that is purchased is for gifts, and of course diamonds, tableware, watches and even clocks are also popular purchases as gifts. We ever keep this in mind. Who gives a gift wishes it to be worthy. We aim to get on good terms with the public and aid gift hunters. This is appreciated. Folks like help in solving such problems.

A principle in advertising which I believe holds good in all lines is—well, I have already mentioned it in passing, but to refer to it more specifically, order. No ad. should be a jumble. Don't put too much into your ad. Don't try to tell all about your business in one ad. Give your ad. an idea. Give your idea an ad. This is the way you do when you write an editorial. You do not discuss the split infinitive and the internal policy of Madagascar in the same paragraph. Then why should we discuss watches and rosaries in the same ad. or try to present half a dozen subjects, as some advertisers do? We may put two or three other suggestions into the same ad., but if we do they usually are related. Locketts, brooches and chains, for example, may be dealt with in a single ad.

At Christmas time it is different perhaps. All the world becomes a jumble then. We believe it pays to jam out advertising space full of all sorts of things. Thus we may catch twenty different people with twenty different wants all with the same ad. That is the time when everybody is on the buy in our line and when nothing but a jumble seems to answer the purpose.

Should prices be used in advertising? More particularly should a jeweler advertise prices? Most emphatically, yes. By

advertising prices the jeweler familiarizes the public with prices. It is well for people to know what a thing is going to cost before they come to the store. If they know the cost and want the article, they have the opportunity to decide in advance whether they can afford it. Otherwise they might come and learn the price and then go away to think it over. There is something, too, in the psychology of the thing. A figure that might strike you as high at first might possibly look well within your reach after you had come to think about it and had reconciled yourself to it. The thoughtful advertiser will prime his public in prices as well as in goods. And the principle holds good at all times.

In the end there is no use of advertising at all if you do not live up to every word of your advertisements. Represent goods just as they are. Sell them as you represent them. Do just as you say you will. Don't take advantage of people. In our line we might commit all sorts of fraud upon an unsuspecting public and make money at it for a short time, but for a short time only, and then where would our business be? The old-fashioned saying, "Honesty is the best policy," is still full of 18 karat truth.

Just Reason for Optimism.

RECAPITULATION of the comparative statistics that are considered the best measures of commercial and industrial conditions indicates that the memorable crisis of October, 1907, did not unsettle the foundation of things, nor did it produce a situation from which recovery must of necessity be prolonged. It may take a little more time on account of the propinquity of election day, and the mental attitude which controls the return of confidence may retard the tightening of the clutch that brings the power of the engine to bear upon the wheels, but there is nothing radically wrong.

Nothing is worn out in the American machine. It is comparatively new. This country abounds with natural resources that are only partially developed. The ground has scarcely been scratched in some of the mineral regions, and little of the vast agricultural area has reached the point where any fertilization is necessary beyond scientific alteration of crops. It can easily compete in production of grain with older nations where crops can only be raised by the use of expensive chemical fertilizers.

The outside world is dependent upon 8,000,000 bales of our cotton that assures an income of about \$400,000,000 annually for this single product. It is only another evidence of the nation's comparative youth that its currency laws are inadequate, and this difficulty will be remedied as the subject of finance receives more attention. Even now there is a safety about the quality of our money that is far better than elasticity with less solidity.

Little tangible excuse exists for pessimism, and it is not stated that any of the croakers have joined the army of aliens who returned to Europe this winter. Most of these aliens will be immigrants again when the snow is off the ground.—H. C. Watson, in *American Review of Reviews* for March.

*Paper read at the meeting of the Western Iowa Editorial Association at Council Bluffs, Feb. 21.

1 2 3 4 5 6 7 8 9 0 1 9 0 8 A B C D E F G H I J K

1 **Alphabet and Figures** **1**
9 **FOR CLASS RINGS, EMBLEMS, ETC..** **9**
0 _____ **0**
8 **HERPERS BROTHERS,** **8**
 SETTING MANUFACTURERS,
 Newark, N. J.,
 1 9 0 8
1 9 0 8 A B C D E F G H E T C . 1 9 0 8

Janitschek Company, Incorporated

Makers of the Modern Steel Stamping DIE—Patented.

Use it and Save Time, Labor and Money.

THIRTY-THREE UNION SQUARE NEW YORK

TRY A DIE AT OUR EXPENSE

Hundreds of our DIES in use and not one dissatisfied user.

No design too intricate, none too simple—No work too large, none too small.

Established and in business since 1894

OUR BUSINESS

DIES

We have been giving satisfaction for the past 14 years.

FINE DIE WORK IS ESSENTIAL FOR FINE JEWELRY, SILVERWARE, ETC. Write us and let us submit for your approval a selection of original designs, made especially to suit your needs.

CREES & COURT Die Sinkers and Designers 91 Sabin St., Talcott Bldg., PROVIDENCE, R. I.

JOHN AUSTIN & SON

Assayers, Refiners and Smelters

74 & 76 Clifford Street PROVIDENCE, R. I.

We Do Our Own Smelting.

Frank Dederlok. Established 58 Years. James E. Dederlok

James H. Dederick's Sons,
Assayers and Bullion Dealers.

All qualities of Gold and Silver, in Plate, Square and Round Wire, Rolled to any gauge. We are selling fine gold for \$1.04 per dwt. which we guarantee to be government assay bars. Small rolling for the trade.

ALL QUALITES OF GOLD AND SILVER SOLDER.

16 Maiden Lane NEW YORK. We buy Old Gold and Silver.



A Small Compound Sand Blast

Price, \$20.00 Foot Bellows, \$6.00

WORKS AS EFFECTIVELY WITH FOOT BELLOWS AS WITH POWER BLOWER :: :: ::

MADE of Galvanized Sheet Iron, 10 inches diameter, Glass Top, Fittings of Brass and Iron, practically indestructible. Satisfaction guaranteed. Ask your Jobber for it, or write to us. Other Specialties: Zeuner's Best Jewelers' Saws; American Swiss Files, equal to the best imported; Gas Furnaces, for Melting, Annealing, etc., etc.; Positive Pressure Blowers.

E. P. REICHELME & CO.
 JEWELERS' TOOLS, FILES AND SUPPLIES
 24 JOHN STREET, NEW YORK

LEIMAN'S AUTOMATIC CONTINUOUS FEED

SAND BLAST

\$15 AND UP Guaranteed

FOR ALL CLASSES OF WORK Used with Foot Bellows or Blower

PRESSURE BLOWERS \$17 AND UP

For Sand Blast, Gas Appliances, etc. NOISELESS—STEADY FLOW

JEWELERS' MACHINERY and Work Benches

ENTIRE PLANTS LARGE OR SMALL EQUIPPED

LEIMAN BROS. 145 BRILL ST. NEWARK, N. J.
 139 CENTRE ST. NEW YORK. MANUFACTURERS



WORKSHOP NOTES AND QUERIES

[Answers are also solicited from our readers to the questions published on this page.]

QUESTION No. 2116.—Gold and Silver Tests.—Will you kindly mail us a formula for testing 14-kt. gold, 18-kt. gold, and sterling silver?
D. S. S.

ANSWER:—The testing of gold and silver by other means than actual assay is getting more difficult in late years on account of the different metals used in alloying the precious metals. Formerly silver and copper were used almost exclusively for alloying gold, but of late years zinc, copper, nickel, etc., metals which are less liable to tarnish than copper, were used in part. When low-karat jewelry is made such as would be represented by eight, 10 or 12 kt. gold. For testing such gold, the testing needles and touchstone are still the most handy means, and, while not being accurate in every instance, an experienced practitioner can still use them successfully. For testing 18-kt. gold and upward, aqua regia will furnish a proper test. Aqua regia composed of two-thirds of nitric acid and one-third hydrochloric acid, both chemically pure, will turn black any gold below 18-kt. gold, when touched with this acid, and will turn 18-kt. gold up to 22-kt., different shades of brown, and lighter shades as the gold is finer. **Silver Testing.**—There are different ways of testing white metal for silver. Silver may be tested, like gold, by standards on the touchstone. Special acids are required for such tests. These acids are compounded by specialists and require renewing. For a person engaged in the retail jewelry business a good test is to file; silver files smoothly and any base metal like tin, or its composition, will be quickly recognized by the tearing action of a new file. Brass or its alloys, and German silver, file harshly and make a greater noise. Another test is the acid test. Silver, on being touched with nitric acid, will turn pure black, while most all the base metals will turn green. Even much-alloyed silver, as 75 per cent. to 25 per cent. alloy, will turn greenish, but it still shows a blackish tint. Plated articles must be submitted to the action of the file. Remove the coating of the plating and expose some interior spot.

QUESTION No. 2117.—The Smallest Watch.—What is the exact size of case in the smallest watch ever made? Can you tell me when it was made, and by whom?

R. B.

ANSWER:—The only reliable account extant of the making of any very small watch is the one relating to the making of such a watch by Pierre Caron, of Paris, which was made about the year 1760, and which measured about $4\frac{1}{2}$ lines of a French inch. Further measurements are not given, except

that this watch movement was worn by Madame Pompadour.

QUESTION No. 2118.—Composition of Silver Dollar.—What is the exact proportions and what are the metals contained in a silver dollar?
F. V. C.

ANSWER:—A silver dollar weighs 412 grains troy and contains 90 per cent. of pure silver and 10 per cent. of alloy, which is generally two-thirds copper and one-third of some other hardening metal, which will not interfere with the use of the silver for mechanical purposes. The trade dollar weighs 420 grains, and is of equal fineness as the modern coin.

QUESTION No. 2119.—French Gray.—Please give me a good formula for producing French gray finish on silver in an inexpensive manner.
J. C.

ANSWER:—The use of platinum chloride for the production of gray finishes can be reduced in cost by adding tincture of iron. This mixture is produced by using equal parts of the platinum chloride and the tincture of iron, which produces an excellent black on the silver, which, when relieved, will make a good gray finish. In order to prepare this solution the metallic platinum may be reduced in a solution of one part nitric acid and three parts muriatic acid. When all the metal is dissolved, the liquid is evaporated almost to dryness and the residual salt is then dissolved in water, alcohol or ether. The tincture of iron is then added. This solution may be used cold, but warming would harden the surface. A cheap method is to use the regular sulphuret in the production of the gray finish. This is done simply by dissolving the sulphuret in warm water, with enough sulphuret dissolved to produce a black solution. In producing the gray with these solutions, the articles will often have to be immersed twice to produce the desired black color. After removing from the solution, the pieces should be left standing for a few moments and then rinsed in water. The pieces are then scratch-brushed lightly, after which they are relieved or shaded. This is preferably done with a muslin cloth buff with very fine pumice, moistened with water. In the deep recesses it is necessary to use a bristle brush to remove most of the black. The operations should be conducted so that the prominent portions will retain a smooth and, if possible, a glossy appearance, the success of the fine gloss, of course, depending on good buffing before attempting the oxidizing. All the gray or oxidized finishes should always be well lacquered and baked on with considerable heat, if possible.

QUESTION No. 2120.—Printing on Celluloid.—Kindly give me a formula for print-

ing designs on celluloid combs and hat ornaments.
P. C.

ANSWER:—Celluloid can be printed with a rubber stamp, which should be made to conform to the shape of the combs or ornaments. The different coloring substances to be used are dissolved in vinegar essence, acetic ether or acetic acid. This prevents the color from running. This may not prove sufficient with all kinds of celluloid. In such cases moisten with oil of turpentine or melted turpentine wax. Any kind of bronze may be used and prepared by mixing 100 grains of finely ground damar-resin with 30 grains of calcined soda and heat to fusion, in which state it is maintained two or three hours with frequent stirring. When cool, grind and pour nine cubic centimeters of petroleum benzine over it in a flask. Shake repeatedly until most is dissolved. Let settle, then filter. Into the filtrate put 300 to 400 grains of bronze powder. If too thin, add more powder until it is of the right consistency for printing.

QUESTION No. 2121.—To Oxidize Silverware.—Kindly give me a receipt for oxidizing silverware.
J. C.

ANSWER:—First clean the silver in strong hot potash, or in a cyanide dip. The chemical used for oxidizing is potassium sulphite dissolved in warm water, strong enough to obtain the shade desired. To preserve the oxidizing, it is necessary to lacquer the articles and have them well dried in the drying oven.

New Method of Making Chains Invented by a German Jeweler.

IN manufacturing chains to be used as jewelry, the soldering of the link joints has always been a troublesome operation, says the *Brass World*. The difficulty has been to apply the piece of solder to the joint. To overcome this difficulty, a wire with a core of solder has been used. The solder which is employed in such instances is either a silver alloy or similar hard solders.

The use of the core of silver solder is open to the objection of cost and the fact that the solder runs so freely that it not only covers the joint but runs over the surface of the link. The links are thus frequently, although unintentionally, rendered rigid and much labor must be spent in cleaning up.

Max Fessler, of Pforzheim, Germany, the largest jewelry manufacturing city in the world, has invented a method of soldering chain links which is somewhat novel (U. S. Patent 876,792, Jan. 14, 1908). Instead of the silver-solder core, he employs the ordinary spelter solder wire containing as much zinc as possible. This he calls "black brass." It is, however, ordinary brazing solder.

This solder has the property of becoming plastic before it actually melts and use is made of this property. The joints are heated in the usual manner, but not to the actual melting point of the solder. A "softening" heat is employed. In this manner, the joints unite without the need of flowing the solder and the labor of cleaning up the joint is very small.

C. DORFLINGER & SONS

36 MURRAY STREET

NEW YORK



Hand-Made Blanks only.
Cut, engraved and etched
glass. Light, medium
and heavy stemware,
tumblers, etc.

NOVELTIES

FANS

For the Jewelry Trade

A complete stock of un-
usual and exclusive
designs

Louis Steiner



NOVELTIES

FANS

of Every Description

An assortment of Fans
that is unequalled in
this country

520 and 522 BROADWAY
NEW YORK

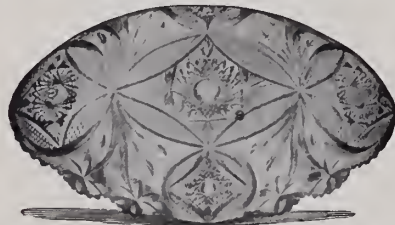

" Wild Rose," No. 122—14-inch
Ice Cream Tray

Irving Cut Glass Co. Inc.

Manufacturers of

Artistic Cut Glass

HONESDALE, PA.

F. W. REICHENBACHER
New York Representative
No. 25 WEST BROADWAY, Room 43

The St. James

Cor. Walnut and 13th Sts., Phila., Pa.

THE IDEAL HOTEL OF
THE QUAKER CITY

A spacious fire and burglar proof
safe has been provided for the con-
venience of the trade. Palatial
rooms with bath \$2.50 per day
and up. Rooms without bath,
(running water) \$2.00 and up.

EUGENE G. MILLER, Mgr.



No. 164.
FLORENCE.

Owanda Cut Glass Co.

Manufacturers of

Rich Cut Glass

Originators of New Designs

HONESDALE, PENNSYLVANIA

A complete line of our high-grade goods shown at our
New York Office, 68 West Broadway.

JACOT MUSIC BOX CO.

MIRA MUSIC BOXES
AND MIRAPHONES

39 UNION SQUARE - NEW YORK.

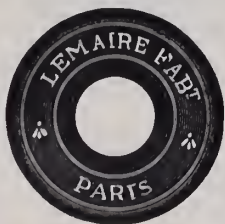

LEMAIRE OPERA GLASSES

LEMAIRE FIELD GLASSES

Best in the World. Used in the Army and Navy.

SUSSFELD, LORSCH & CO., Importers

37 MAIDEN LANE, NEW YORK

MARQUE DE FABRIQUE



All Genuine Glasses
Bear This Mark
Large Variety in All
the Latest Styles

THE CONNOISSEUR



Devoted to Art Pottery, China, Marbles, Bronzes, Cut and Decorated Glass Ware, Bric-à-Brac, Lamps, Art Metal Wares, Fancy Goods and Kindred Lines.



EARLY ENGLISH POTTERY—POSSET POTS

By Clement W. Coumbe.

(Continued from issue of April 15.)

WHAT is a "posset pot"? Readers have frequently had the title posset pot figuring in ceramic auction sales, and even reproductions of examples have appeared in these columns. Well, the first part of an explanation of the term is to define what "posset" is.

From time immemorial it has been the habit of the gregarious human biped to "foregather" his "clans"—for kinsmen to meet and jubilate on certain occasions. And certain church feast days are the most popular dates for such family reunions. In the 17th century Christmas was so celebrated by most Christians, and pledging good-will over the "flowing bowl" was the precursor of our present day high-ball degeneracy. And on Christmas Eve in the cold, raw climate of Stafford, Derby and other English Midland Shires it became customary to "celebrate" in "posset" at the genial supper hour. Posset was a mixture of hot ale, sugar, spices and "sippets" (dice-shaped pieces of bread or oat-cake). It was truly a "happy day" in the annals of those rough country folks, and the ceremonies attached to the occasion are worth repeating in this posset pot story.

The mistress of the house presiding over the festivities first brewed the spicy drink and then dropped therein her wedding ring. A silver coin followed the golden hoop. Then she passed the posset pot around among the assembled guests and each in turn dipped a spoonful of the beverage as it passed from hand to hand. The fortunate individual that spooned out the coin was assured of good luck throughout the ensuing year, and the guest who brought to light the ring was always certain of an early and happy marriage.

And this was the mystic rite of the posset pot, which utensil, being used over and over every year, was stored and cherished as a sacred heirloom from generation to generation. Figuring in such an important ceremonial and functioning for so many occasions, the posset pot was naturally a piece of pottery ware on which the potter bestowed his utmost genius in construction and decoration. And, as they were usually "made to order," the name of the family for whom posset pots were created generally appeared somewhere on their outer surface.

A typical posset pot is roughly outlined in Fig. 1. It is in the Willett collection

at the British Museum. Its date appears (1706) among the slip raised decoration. Interesting is the inscription, which reads: "I. W. May 27 day 1706. A B C D E F G H I L K. A. K." It is supposed by experts that this peculiar abbreviated alphabet is a humorous potter's rebus conveying

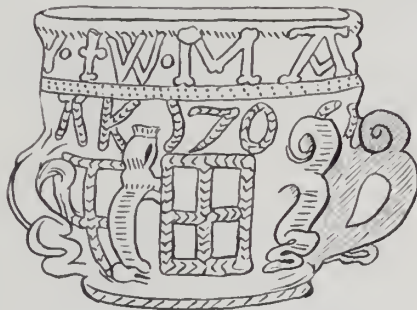

FIG. 1—POSSET POT WITH EIGHT HANDLES.

the meaning of being a present "from A. to K." It is of greenish glaze, eight inches high by 7¼ inches diameter, and it has no less than eight handles. The original style of the early Staffordshire potter is too clear to admit of doubt as to its birthplace.

But posset pots do not by any means all



FIG. 2—A NOTTINGHAM POSSET POT.

originate from the Staffordshire clay pits. These festive utensils were made and used in Derbyshire, which district turns them out to this day and has done so from an early period. Nottingham also has done its share in posset pot production, and Brampton has been making them for centuries, as it still

does. Usually the name of the person or family for whom it is made is *incised* on the pot.

An example of a Nottingham posset pot is given on this page (Fig. 2). It is made more carefully and of lighter construction than is usual. It stands 10½ inches high and is 9½ inches in diameter at the mouth, and is in a hard and durable ware. The inscription reads: "Samuel Watkinson and Sarah his wife, Major and Majoress, of Nottingham."

A peculiar feature of this special piece is the tube (shown in the picture). This tube commences about an inch from the lip and passes down and then through the body of the vessel, continuing to the bottom inside. On the opposite side there poses in its decoration a "Royal Arms" (William III.) with crest, "supporters" and motto.

Wrotham also produced posset pots as well as tygs, but, as in the latter case, they were of more refined and better workmanship and decoration than the Staffordshire pieces.

A feature in connection with posset pots that is of special interest to the retail jeweler who handles bric-à-brac is the fact that—as they are considered as heirlooms by their owners—they have been preserved with greater care, and therefore they are more plentifully extant. Among the British emigrants in this country there must be many of these pieces, and they are liable to present themselves before the dealer at any time. Hence these lines, that he may recognize them and their value.

(To be continued.)

An Opportunity to Push American Cut Glass in Europe.

A REPORT has been received from an American consular officer located in one of the cities of western Europe, in which he states that attention should be called to the fact that there is a good opening in that region for the introduction of American cut glass, though no effort has yet been made in that direction. He suggests that manufacturers of this class of goods should send their catalogues and price lists to certain dealers in his district, whose names are on file in the Bureau of Manufactures, Washington, D. C.

Manufacturers interested should write to the Bureau of Manufactures and get the names of the dealers mentioned, referring to the file number of the above report, which is 2,103.

Joseph Wiley, Oaktown, Ind., has sold out to Schonefeld & Lane.



Battle of Hastings

Bayeux Tapestry Underglaze Enamel

The latest production of the **Royal Doulton** factories. Exquisitely enameled in rich colors.

Sole Agent

W.S. Pitcairn

44 Murray Street
New York

Write for Booklet, "Quaint Bits of Royal Doulton"

WE WILL RESUME OUR OLD ADDRESS

☞ One year ago, we left our headquarters of twenty years' standing, to make room for the handsome structure now occupying the site of 15-19 Maiden Lane.

☞ On May 1st, we will occupy our handsome, new quarters, and extend to the trade and our friends in general, a cordial invitation to visit us, and see the growth and development in the distribution of the following well-known lines, the output of our large and well-equipped factories.

- A. L. Co. Gold Pens
- Mercantile Fountain Pens
- Mercantile "Self-Fillers"
- "Beacon" Stylographic Pens
- Gold and Silver Pen Holders
- Gold and Silver Pencils
- "Universal" Outfits
- Gold and Silver Penknives
- Cigar Piercers, Etc., Etc.

SEND FOR COMPLETE CATALOGUES TO-DAY

Aikin-Lambert Co.

Established 1864

15-19 Maiden Lane, NEW YORK

Send for the Latest Styles in MONOGRAMS and INITIALS

as manufactured by

Thomas J. Dunn Co.

101 Chambers Street
NEW YORK

Makers of Exclusive Styles in

Monogram

Fobs

in Gold, Sterling and Rolled Gold Plate

Our 1908 Ladies' Belt Buckles are most original and artistic.

Specialties in the Monogram and Initial line
Send for Illustrated Sheets



THE R & L OIL

The R. & L. Oil is made especially for those expert watch and clock makers who must have the best and most reliable oil on the market. It does not gum or change, and possesses all the

requisites needed for the most delicate mechanisms. Send 25c. to your jobber, asking for R. & L. Oil.

Wholesale Selling Agents

- M. SICKLES & SONS . . . Philadelphia
- SWARTCHILD & CO. . . Chicago
- NORDMAN BROTHERS CO., . . San Francisco
- D. C. PERCIVAL & CO. . . Boston
- CHAS. MAY & SON . . . Boston
- DANIEL PRATT'S SON . . . Boston
- 53 Franklin Street, Boston
- SUSSFELD, LORSCH & CO., . . New York City
- H. S. MEISKEY CO. . . Lancaster Pa.

RANLETT & LOWELL CO.

SOLE MANUFACTURERS
Jewelers' Building BOSTON, MASS.

CROUCH & FITZGERALD



Jewelry Trunks and Cases

177 Broadway,
Bet. Cortlandt
and Dey Sts.
688 Broadway,
723 6th Ave.,
New York.

New York Tortoise Shell Co.

18 EAST 30TH STREET,
Just East of Fifth Ave.

NEW YORK

Manufacturers of Fine

TORTOISE SHELL GOODS

Repairing given prompt attention.

CASTINGS Gold, Silver, Bronze, Brass, German Silver, Copper and Iron.

L. D. TEL. 2072 L. Supply Jewelers, Silversmiths, Die-makers, Mould-makers, etc. Bronze Forces, Hard Bronze and Iron Shells for Die-cutting Machines. Cast Iron Hub for sinking in Steel Dies. Chandeller, Undercut Work, Statuary.

AUGUST GRIFFOUL 313 HALSEY STREET
NEWARK, N. J.

BUYERS' INFORMATION BUREAU

Questions as to the makers of certain lines of goods, where to buy certain lines, where certain kinds of work are done, the owners of certain trade-marks and other matters relating to the buying branch of a jewelry business will be cheerfully answered under this department. All queries are also answered promptly by mail.

TRENTON, N. J., Feb. 23, 1908.

Editor of THE JEWELERS' CIRCULAR-WEEKLY:
Can you supply us with the name of the company selling lamps burning denatured alcohol?
A. F. R. L.
ANSWER:—Manning, Bowman & Co., Meriden, Conn.

EDWARDS, N. Y., Feb. 21, 1908.

Editor of THE JEWELERS' CIRCULAR-WEEKLY:
Can you inform me who imports or handles incandescent mantels for oil lamps?
D. M. McK.
ANSWER:—Mr. Wichlan, 47 Murray St., New York.

OMAHA, Nebr., March 6, 1908.

Editor of THE JEWELERS' CIRCULAR-WEEKLY:
Where can I procure a solid gold fish suitable for a watch charm that is flexible to a certain extent?
M. C. F.
ANSWER:—Emrich, King & Schorsch, 42 E. 14th St., New York. They are made in plated ware by the W. & S. Blackinton Co., North Attleboro, Mass.

ALBANY, N. Y., March 16, 1908.

Editor of THE JEWELERS' CIRCULAR-WEEKLY:
Kindly advise us as to the manufacturers of nine-inch silver plated soda fountain ladles.
J. F.
ANSWER:—International Silver Co., Meriden Conn., and J. W. Tufts, 282 Congress St., Boston, Mass.

ASHEVILLE, N. C., March 12, 1908.

Editor of THE JEWELERS' CIRCULAR-WEEKLY:
Please advise us who takes subscriptions for *La Bijou*, a journal of designs published in Paris.
A. M. F. Co.
ANSWER:—International News Co., 83 Duane St., New York.

CONCORD, N. H., Feb. 27, 1908.

Editor of THE JEWELERS' CIRCULAR-WEEKLY:
Can you inform us what concern makes the King George pattern in sterling silver flat ware?
N. C. N. & Co.
ANSWER:—Gorham Co., Fifth Ave. and 36th St., New York.

NEW BEDFORD, Mass., April 2, 1908.

Editor of THE JEWELERS' CIRCULAR-WEEKLY:
Can you give me a list of the leading English watch papers published?
H. R. R.
ANSWER:—Watchmaker, Jeweler, Silver-smith & Optician, 150 Holborn, E. C., London; *Jewelers & Watchmakers' Trade Advertiser*, 87 Edmond St., Birmingham; *Jeweler & Metal Worker*, 24 Clerkenwell Road, E. C., London.

NEW YORK, March 4, 1908.

Editor of THE JEWELERS' CIRCULAR-WEEKLY:
Will you kindly inform me what the duty on silverware imported into this country from Germany is?
F. N.
ANSWER:—Manufactures of silver for other purposes than personal adornment, 45 per cent. ad valorem; silver jewelry—that

is, articles of silver, plated or otherwise—for personal adornment, 60 per cent. ad valorem.

CHARLESTON, W. Va., April 11, 1908.

Editor of THE JEWELERS' CIRCULAR-WEEKLY:
Who makes the Plato clock?
F. M.
ANSWER:—The American Electrical & Novelty Mfg. Co., Hudson and Spring Sts., New York.

ATLANTA, Ga., March 1, 1908.

Editor of THE JEWELERS' CIRCULAR-WEEKLY:
Can you give us any information about several pieces of silver bearing the mark "C" in a shield?
D. & F.
ANSWER:—These pieces of silver are of English make, bearing the authentic hall mark of the assay office. The letter C stands for the year in which the goods were made, 1793 or 1799.

NEW YORK, April 3, 1908.

Editor of THE JEWELERS' CIRCULAR-WEEKLY:
Can you give me any information regarding the Cheshire Watch Co.?
G. B.
ANSWER:—The Cheshire Watch Co. was organized in New Haven, Conn., for the manufacture of watches in 1883, but some years afterwards became bankrupt, discontinued business and has had no successors.

JERSEY CITY, N. J., March 24, 1908.

Editor of THE JEWELERS' CIRCULAR-WEEKLY:
Can you tell me who makes the new tool for cutting metal mentioned in your issue of Sept. 6, 1905?
E. H. T.
ANSWER:—Koch & Co., Elberfeld, Germany.

NEWARK, N. J., Feb. 15, 1908.

Editor of THE JEWELERS' CIRCULAR-WEEKLY:
I have an old grandfather's clock, the works of which have been worked out by hand, the numbers on the brass dial are all hand engraved, the hands are steel and pierced, and even the brads in the frame are hand forged, the motive power is one large weight on a continuous piece of rope. The name on the dial is James Wittaker. Can you give me the name of this "old fellow"?
J. R.
ANSWER:—From our records James Wittaker appears to have been in business during the year 1700. It would be difficult to give you the exact age of the clock, but it is safe to assume that it is in the neighborhood of 200 years old from the description which you give.

WHITE PLAINS, N. Y., Jan. 27, 1908.

Editor of THE JEWELERS' CIRCULAR-WEEKLY:
We have a grandfather's clock with the name of Jacob Hunizker nicely lettered across the back. Was he a clockmaker and how old would this clock be?
E. P. B.
ANSWER:—We have no record showing the name of such a clock manufacturer. We are inclined to believe that instead of being a manufacturer he was simply a dealer.

Some Benefits of Organization.

(By I. M. RAOBAUGH, Secretary of the American National Retail Jewelers' Association.)

TO the casual observer it might seem that the efforts being put forth in organization work were not producing results, but such is not the case. All trades, professions and nearly all lines of mercantile interests are being organized. The jewelers, I am sorry to say, were among the last to awaken to their need of organization, notwithstanding the fact that they needed it most. But the awakening came and 28 State, 10 local or city, and one National Association is the result.

Now what is being done? First, I want to impress upon you the idea that the very

first thing to do is to organize. We cannot accomplish the results desired until we are more thoroughly organized. The manufacturers and jobbers are awakening to the fact that it is "up to them" to protect the interest of the retail jeweler for the retailers in all lines are different now than 20 years ago.

The manufacturers in various lines are no longer willing that the mail order fellow should set the price, and while some have not as yet seen the folly of their ways, yet there is still grounds for hope. There are more watch companies, more silverware manufacturers, more jewelry manufacturers, and more jobbers who are catering directly to, and protecting the interests of the retail jeweler to-day, than ever before.

Stamping laws, both State and national, have been enacted for the elevation of the retail jewelry business and the protection of the public. And last, but by no means least, the association work is making better business men out of the retailers. This alone is worth the cost and effort and should not be lost sight of.

Now for some of the things we are laboring for and hope to bring about: We hope to form a first-class working association in every State in the Union, and then have them all affiliated with the American National Retail Jewelers' Association. We hope to show the retailing jobber that it will be better business for him to sell at wholesale only. We are trying to prove to the manufacturer and jobber, who furnishes his goods, or allows them to be furnished to the retail mail order house, that it is unfair to the retailer who handles by far the larger portion of his goods. That it is not only unfair, but is against the principles of good business for him to sell to the small retailer at one price, and to the large retailer at a lower one.

We hope to have laws enacted to protect the public against unscrupulous and dishonest manufacturers, and thereby eliminate the dishonest competition in the trade. We are planning to establish an assay bureau, where any member of our association can find out just what quality of goods he is paying his good money for. We are endeavoring to have the retailer rise above the petty jealousies that now exist and to broaden out and get a larger view of the possibilities and privileges of the retail jewelry business.

Now to the point, brother retailer: We need you and you need us and why not get together? If you are not a member of some association of retail jewelers, you should be, and be assisting in the upbuilding of the business. Every retailer enjoys the benefits of the efforts put forth, whether he be himself an active worker or not, and each should be anxious to do his part.

Join the association, attend the meetings, breathe the air that is rife with the spirit of organization, broaden out, strengthen up and take a new lease of life, and the millennium will not be slow to dawn for that most noble of all craftsmen—the retail jeweler.

The store of T. K. Smith, Oskaloosa, Ia., was broken into, about a week ago, by burglars who stole \$500 worth of jewelry.

WM. F. RENZIEHAUSEN CO.

'Phone 3759-R.

43-47 Oliver Street, NEWARK, N. J.

Gold and Silver Refiners

PROMPT RETURNS MADE FOR ANY MATERIAL CONTAINING PRECIOUS METALS
DEALERS IN GOLD AND SILVER, AND ROLLERS OF STERLING SILVER

Gold and Silver Anodes a Specialty



Correspondence Solicited

TRADE  MARK

ESTABLISHED
1850

HAND BAGS

We have a very extensive collection in all desirable leathers

C. F. RUMPP & SONS
FINE LEATHER WARE

Fifth and Cherry Streets
PHILADELPHIA

New York Salesrooms, 683 and 685 Broadway

Importer and Manufacturer of
WATCH MATERIALS, TOOLS, JEWELERS'
SUPPLIES AND OPTICAL GOODS



Bargains
in
Engraving
Blocks

Prices on
Application.

Fine Gold, Silver and Platinum always on hand.
Highest Prices paid for Old Gold and Silver.

A. ZAREMBOWITZ
250 East Houston Street NEW YORK

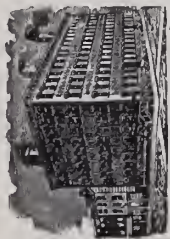

L. LELONG & BRO.

Gold and Silver Refiners, Assayers and Sweep Smelters

S. W. Cor. Halsey and Marshall Sts., NEWARK, N. J.

Prompt attention given to Gold and Silver Bullion.

SMELTING FOR THE TRADE.

Established 1879

Manufacturer of

LOUIS W. HRABA  **Fine Leather Goods**

29 East 19th St., New York

Exclusively for the Jewelry Trade

HERMAN KOHLBUSCH, Sr.,

ESTABLISHED 1859.

Manufacturer of Fine Balances and Weights
for every purpose where accuracy is required.

Office and Salesroom, 194 BROADWAY, NEW YORK.

Send for Price List.

Tel. 370 Cortlandt.



CRUCIBLES.

Jewelers' Supplies,
Etc.

Established 1850.

J. & H. BERGE,
96 John Street,
NEW YORK.



ESTABLISHED
1886

CEO. M. BAKER

TELEPHONE
UNION 1493-R

Gold and Silver Refiner and Sweep Smelter

Office, 91 Page St. }
Works, 77-85 Page St. } PROVIDENCE, R. I.

Our processes are strictly up to date
and facilities most complete for doing
all kinds of refining.
Specialties: Prompt and good returns.

PATENTS

obtained on inventions and designs. Trade-
marks, prints and labels registered.

R. W. BISHOP,
ATTORNEY-AT-LAW,

908 C Street N.W., Washington, D.C.

PLATINUM AMERICAN PLATINUM WORKS
NEW YORK OFFICE
41 Cortlandt Street
NEWARK, N. J.

Nothing New Under the Sun?



Oh Yes, There Is! **“INVICTA” SAWS** Are New. Order a Gross and Try Them and Be Convinced

WILLIAM DIXON, Incorporated, 39 John St., New York
Formerly F. W. Gesswein Company



TIME-SAVING equipment and methods that help us get every fractional value out of the filings, waste, sweep and scrap consignments treated by us. We do the work expeditiously and as a rule remit for more than the consignor expects his shipment to yield. Write us.

CONLEY & STRAIGHT
236 Eddy St., Providence, R. I.

**REFINERS
ASSAYERS
SMELTERS**

REFINERS OF GOLD AND SILVER, ASSAYERS AND SWEEP SMELTERS - DEALERS IN FINE GOLD, SILVER AND PLATINUM, ALL KINDS OF GOLD AND SILVER ANODES



WE BUY

Old Gold and Silver Filings, Polishings, Sweeps, Hand Washings, etc. We will make accurate valuations and hold consignment subject to your acceptance. If valuation is not satisfactory, we reship to you at our expense.

WE PAY FOR OLD GOLD:

22 K. 88c. per dwt.	12 K. 48c. per dwt.
20 K. 80c. " " "	10 K. 40c. " " "
18 K. 72c. " " "	8 K. 32c. " " "
16 K. 64c. " " "	6 K. 24c. " " "
14 K. 56c. " " "	4 K. 16c. " " "

MARKET RATES FOR SILVER AND PLATINUM.

Try us and you will Appreciate our Squareness, Promptness and Accuracy.

T. B. HAGSTOZ, Ltd., Main Office, 709 Sansom St., Philadelphia, Pa.
SMELTERS, ASSAYERS, REFINERS.

WE SELL

Gold, Silver and Platinum, various qualities, rolled flat or drawn to wire of any gage.

PRICES OF ALLOYED GOLD:

8 K. 42c. per dwt.	14 K. 66c. per dwt.
10 K. 50c. " " "	16 K. 74c. " " "
12 K. 58c. " " "	18 K. 82c. " " "

Gold and Silver Solder, either from formulas furnished, or our own. "T. B. H." Alloy, 25c. per oz. Guinea Gold, 75c. per lb. Shot Copper, 40c. per lb. We will send tables for alloying without charge. They save figuring.

UNITED STATES SMELTING AND REFINING WORKS

L. & M. WOLLSTEIN

16 JOHN STREET, NEW YORK

SWEEP SMELTERS AND ASSAYERS

Dealers in Gold and Silver Assay Office Bars. HIGHEST and MOST PROMPT RETURNS made for Sweeps and all kinds of Waste containing precious Metals.

HIGHEST PRICES PAID FOR OLD GOLD AND SILVER

Manufacturers of STERLING SILVER.

Importers of PLATINUM.

Ore and Bullion Assays a Specialty.

WM. BOLLES' SELF-FILLING NON-LEAKABLE FOUNTAIN PENS



SIMPLE—CLEAN—PRACTICAL

We make our own goods—and they have stood five years' test by the largest dealers in the country. Write for Catalogue and Price Lists.

THE WM. BOLLES CO., 1108 JEFFERSON ST., TOLEDO, OHIO

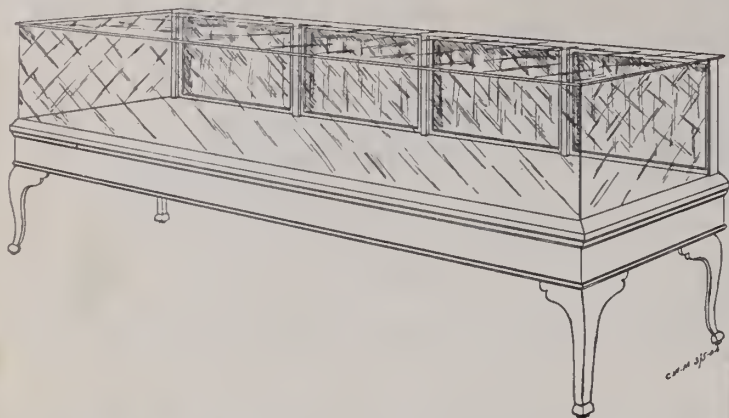

"FOR A QUARTER OF A CENTURY"

We have been manufacturers of

High-Grade Jewelry

Fixtures

Correspond with us before placing your orders

ALEXANDER H. REVELL & CO.

Rees, Dayton, Eastman and Hawthorne Streets,
Chicago, Ill.



Established 40 Years

Every essential quality of piano construction, tone, touch, scale, design, and beauty of finish is combined in the BRIGGS. It is absolutely and unequivocally a standard piano of the world.

Any **SUCCESSFUL JEWELER** can largely increase his profits by the sale of pianos, and many receive the greatest part of their incomes from selling the

"BRIGGS"

We would like to talk this over with reliable concerns in unoccupied territory.

BRIGGS PIANO CO., Boston



A. E. GATES

Jewelry Auctioneer

1 Maiden Lane, New York

I have just closed a sale for E. H. Richards, of El Paso, Texas. Write him for information as to my ability and character. Now, Mr. Jeweler, if you are desirous of securing the services of the best Auctioneer in the Jewelry business and one who is thoroughly familiar with all its

branches, write me for open time. If you are in doubt as to this statement, write me and I will furnish you the names of first-class Jewelers from all parts of the United States for whom I have conducted successful sales, and who will substantiate every word I say. I guarantee satisfaction or you need not pay me one penny for my services. All communications strictly confidential.

WIRE OR WRITE AT MY EXPENSE—Telephone 313 Cortland

A. E. GATES.

